

# CHAPTER 1 - GENERAL CONSIDERATIONS

## 1-07 REFERENCES

In the event these Standards and other applicable rules adopted by Snohomish County do not provide necessary design information, the following publications may be referenced with said reference(s) applying to the publications as adopted and amended. References followed by an asterisk\* are specifically cited in the EDDS text. All references are hyperlinked when a version is available to the public for free.

### A. WSDOT References

#### A. Specific

~~—In the event these Standards and other applicable rules adopted by Snohomish County do not provide necessary design information, the following publications **of the Washington State Department of Transportation (WSDOT) may be referenced with said reference(s) applying to the publications as adopted and amended:**~~

~~—WSDOT Local Agency Guidelines~~

~~• Standard Plans for Road, Bridge and Municipal Construction ("Standard Plans")~~

~~• Standard Specifications for Road, Bridge and Municipal Construction ("Standard Specifications")~~

• WSDOT BBridge Design Manual\*

• WSDOT Construction Manual

~~• Construction Manual~~

• WSDOT DDesign Manual\*

~~• Hydraulics Manual~~

• WSDOT HHighway Runoff Manual (HRM)\*

• WSDOT Hydraulics Manual\*

~~• WSDOT LWSDOT Local Agency Guidelines (LAG Manual)\*~~

• WSDOT Roadside Manual

~~• Roadside Manual~~

• WSDOT Standard Plans\*

• WSDOT Standard Specifications\*

• WSDOT Traffic Manual

~~• Traffic Manual~~

• WSDOT UUtilities Manual\*

- ~~Criteria for Sewage Works Design (Orange Book, WA DOE)~~
- ~~Water System Design Manual (WA DOH)~~
- ~~General Criteria for Sewage Works Design (Orange Book, WA DOE)~~
- ~~Water System Design Manual (WA DOH)~~

#### **B. State and Local References**

- Criteria for Sewage Works Design (Orange Book) (WA DOE)
- Dam Safety Guidelines (WA DOE)\*
- Low Impact Development: Technical Guidance Manual for Puget Sound\*
- Pedestrian Facilities Guidebook
- The following references may also be applicable (with said reference(s) applying to the publications as adopted and amended): Washington Administrative Code (WAC)\*
- Water Crossing Design Guidelines (WDFW)
- Water System Design Manual (WA DOH)

#### **C. Federal References**

- ADA Standards for Accessible Design (USDOJ)
- ADA Standards for Transportation Facilities (USDOT)
- Code of Federal Regulations (CFR)\*
- FHWA Hydraulic Engineering Circular No. 11\*
- FHWA Hydraulic Engineering Circular No. 14\*
- Guide to the ADA Accessibility Standards (U.S. Access Board)
- IESNA Roadway Lighting Handbook RP-8-00 (USDOT)\*
- 2005 Revised Draft Guidelines for Accessible Public Rights-of-Way (2005 PROWAG) (U.S. Access Board)\*
- Manual of Surveying Instructions for the Survey of the Public Lands of the United States (BLM Manual)\*
- Manual on Uniform Traffic Control Devices (MUTCD) (as amended and approved by WSDOT)\*
- National Bridge Inspection Standard (NBIS)\*

#### **D. American Association of State Highway and Transportation Officials (AASHTO) References**

- Guide for Design of Pavement Structures
- Guide for the Development of Bicycle Facilities
- Guidelines for Geometric Design of Low-Volume Roads
- Guide Specifications for the Design of Pedestrian Bridges\*
- LRFD (Load Resistance Factor Design) Bridge Design Specifications\*

- Manual for Assessing Safety Hardware (MASH)\*
- A Policy on Geometric Design of Highways and Streets (Green Book)\*
- Roadside Design Guide\*-(AASHTO)
- Standard Specifications for Highway Bridges\*

— Guidelines for Geometric Design of Low Volume Roads (AASHTO)

### **E. Other References**

- International Building Code (IBC)\*
- International Fire Code (IFC)
- Open Channel Hydraulics, Ven Te Chow, 1959\*

### **F. Other Federal and State Standards**

The design criteria of other agencies including the Federal Housing Administration (FHA), Department of Housing and Urban Development (HUD), U.S. Army Corps of Engineers, U.S. Coast Guard, U.S. Fish and Wildlife Service, U.S. Forest Service, U.S. Department of Transportation, the Transportation Improvement Board (TIB) or any other federal or Washington State agency may also be applicable even if they are not specifically or generally referenced in the EDDS.

### **G. Precedence**

1. ~~WSDOT Local Agency Guidelines~~
2. ~~Transportation Improvement Board (TIB) Guidelines~~
3. ~~Design criteria of federal agencies including the Federal Housing Administration (FHA), Department of Housing and Urban Development (HUD), and the Federal Highway Administration (FHWA), Department of Transportation~~
4. ~~A Policy on Geometric Design of Highways and Streets, American Association of State Highway and Transportation Officials (AASHTO)~~
5. ~~LRFD (Load Resistance Factor Design) Bridge Design Specifications (AASHTO)~~
6. ~~Standard Specifications for Highway Bridges (AASHTO)~~
7. ~~Guide Specifications for Design of Pedestrian Bridges (AASHTO)~~
8. ~~Manual on Uniform Traffic Control Devices (MUTCD), (U.S. Department of Transportation,)~~
9. ~~IESNA Roadway Lighting Handbook RP-8-00, (U.S. Department of Transportation)~~
10. ~~—~~
11. ~~—~~
12. ~~—~~
13. ~~Hydraulic Code Rules (Chapter 220-660 WAC)~~
14. ~~Dam Safety Guidelines (Dam Safety Division, Washington State Department of Ecology)~~
15. ~~Roadside Design Guide (AASHTO)~~
16. ~~International Building Code (IBC)~~

- ~~17. International Fire Code (IFC)~~
- ~~18. —~~
- ~~19. —~~
- ~~20. —~~
- ~~21. Guidelines for Geometric Design of Low Volume Roads (AASHTO)~~
- ~~22. Guide for the Development of Bicycle Facilities (AASHTO)~~
- ~~23. Guide for Design of Pavement Structures (AASHTO) Criteria for Sewage Works Design (Orange Book, WA DOE) Water System Design Manual (WA DOH)~~

In cases where these Standards conflict with the standards or procedures of the Washington State Department of Transportation (~~WSDOT~~WSDOT) or the Federal Highway Administration (~~FHWA~~FHWA), the state or federal requirements shall take precedence for county road projects with state or federal funding.

## **1-09 PERMITS**

Other permits, approvals or agreements may be required by the County or other jurisdictions prior to initiating any activities subject to these Standards. It is the project applicant's responsibility to obtain all necessary permits. Questions regarding such permits, approvals or agreements should be directed to the County Departments of Planning and Development Services or Public Works, as appropriate.

# CHAPTER 4 – ROAD ELEMENTS AND FEATURES

## 4-03 SURVEY MONUMENTS AND CORNERS

See Standard Drawing 4-130

### ~~A. General~~

#### A. Permit for Removal

~~1.~~ In accordance with Chapter [332-120](#) Washington Administrative Code ([WAC](#)), no survey monument as defined therein shall be removed or destroyed without first obtaining a permit from the Department of Natural Resources. Any party causing the removal or destruction of a survey monument shall be responsible for ensuring that the original survey point is perpetuated.

#### B. Responsibility for Replacement

~~2.~~ All existing survey control monuments that are disturbed, lost, or destroyed during surveying or construction shall be replaced, at the expense of the responsible party, by a land surveyor registered in the State of Washington.

#### C. New Survey Monuments

~~3.~~ New survey monuments shall be installed in accordance with the provisions of this section 4-03. Standard steel reinforcing bars shall be at least 1/2 inch in diameter; steel pipes shall be at least 3/4 inch inside diameter, typical minimum length is 24 inches. Pipe or rebar shall be permanently tagged with the land surveyor's registration number. Specifications for roadway monuments are provided in Standard Drawing 4-130.

#### D. Boundary Establishment

~~4.~~ Boundaries of ~~final plats, short plats and binding site plans~~ subdivisions and road establishments shall be established with standard steel reinforcing bars, ~~or steel pipes, or monuments in accordance with Standard Drawing 4-130~~ permanently marked with the land surveyor's registration number. The same ~~corners materials~~ shall be used to mark the corners of subdivision lots, tracts, and NGPA easement and Critical Area Protection Area/Easement (CAPA/E) boundaries. ~~Boundary lines or corners~~ Monuments that represent are section or quarter-section corners shall be marked with standard monuments according to the current Bureau of Land Management (BLM) manual. Refer to Standard Drawing 4-130.

#### E. Offset Monuments

~~5.~~ If a property corner is occupied by ~~a fence post~~ an obstruction, an offset ~~standard steel reinforcing bar~~ monument shall be installed along one of the boundary lines. ~~Offset concrete m~~ Monuments shall only be set and marked according to the current BLM manual when to-witnessing section and quarter-section corners.

~~6.~~ ~~Standard steel reinforcing bars shall be 24 inches in length and at least 1/2 inch in diameter; steel pipes shall be at least 3/4 inch inside diameter. Pipe or rebar shall be permanently tagged with the land surveyor's registration number.~~

#### F. Road Monument Setting & Placement

A monument shall be ~~installed set~~ in accordance with Standard Drawing 4-130 at each intersection of ~~a new plat road centerline with the centerline of an existing county road right of way. all~~ points of curvature (PC), points of tangent (PT), center of cul-de-sac, road centerline intersection

points, intersections of new road centerlines with the centerline of an existing county road right-of-way, at the end of road stubs, and at such intermediate points as determined by the Engineer.

The point of intersection (PI) will be acceptable in lieu of a PC and PT for road curves, provided the PI falls within the paved roadway and approval is granted by the Engineer prior to installing the monument.

7. Monuments at intersections with state highways are subject to the requirements and approval of the Washington State Department of Transportation, or as directed by the Engineer.

~~8. Each monument, case and cover shall be set in accordance with Standard Drawing 4-130, for all points of curvature (PC), points of tangent (PT), center of cul-de-sac and road centerline intersection points. The point of intersection (PI) will be acceptable in lieu of a PC and PT for plat road curves, provided the PI falls within the paved roadway and approval is granted by the Engineer prior to installing the monument.~~

### G. Install Monumentation Prior to Recording

9. All required monumentations shall be installed prior to the recording of a final plat, final short plat, or binding site plansubdivision, road establishment record of survey, or the final of any right-of-way permit for all other types of development. The delayed installation of required monuments shall not be allowed.

~~10. Where an existing monument is on the same tangent line, visible and within 250 feet of the nearest plat boundary line projected to the centerline of a county road right-of-way, only one monument is required. However, a backsight monument must be on the same tangent and visible at a distance of not less than 250 feet from a controlling monument. The distance tie between the existing monument and the intersection shall be shown on all plat or short plat drawings and the final plat or short plat.~~

~~11. Monumentation shall be placed at all public road intersections, boundary angle points, points of curves in public road(s), or at such intermediate points as may be required by the department.~~

### H. Private to Public Road Conversion

12. If a private road is constructed with the intent to be converted to a public road or ~~the~~ a condition is placed on the development to not protest the conversion of the private road to a public road, monumentation shall be required in accordance with sub sections (F & G11) above.

### I. Aquatic Boundaries

If any land in a subdivision is contiguous to an body of water, river, or streamaquatic boundary, reference monuments shall be set along a meanderthe parcel boundary line(s) which shall be established along the shore at such distance back from the ordinary high water markaquatic boundary as to reasonably ensure against damage and destruction by flooding or erosion, bank caving, ice shoving, or wave action. Reference monuments or witness corner monuments will be established as near to the aquatic boundary as practicable. The purpose of the boundary side line reference monuments is to preserve the alignment of and the distance along the parcel boundary. Property lying beyond the meander linereference monuments shall be defined by distance along the side property lines extended from the meander lineto the aquatic boundary.

13.

~~14. All lot and block corners or witness corners shall be set with an iron pipe or steel reinforcing bar at least 24 inches in length, or alternate materials as approved by the department, before recording of the subdivision, short subdivision, or binding site plan. All corners shall be identified with the land surveyor's registration number.~~

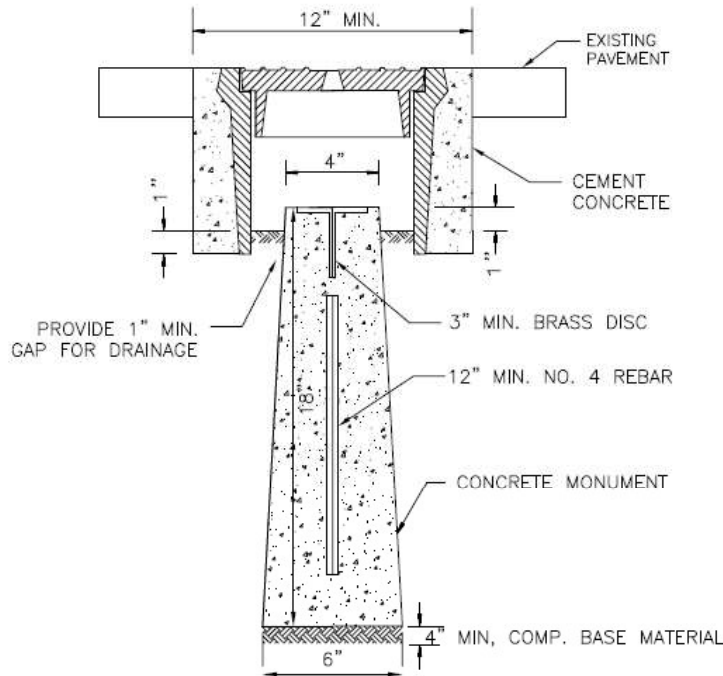

PLAN

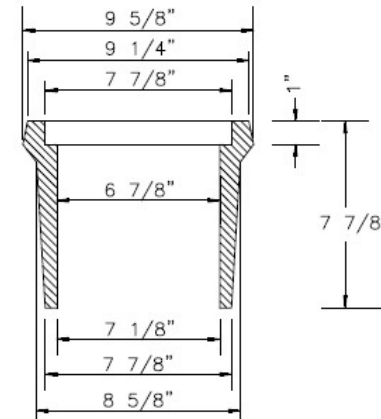
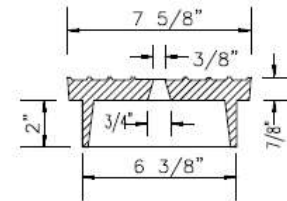

SECTION

NOTES:

- ~~1. THE OFF STREET MONUMENT SHALL BE THE SAME EXCEPT USING A NO. 8 REBAR AND WITHOUT A CASE AND COVER. THE OFF STREET MONUMENT SHALL BE 3" ABOVE GRADE.~~
2. MONUMENT CASE AND COVER SHALL BE CAST IRON.
3. BRASS DISCS FOR NON SNOHOMISH COUNTY PROJECTS SHALL BEAR THE REGISTRATION NUMBER OF THE LAND SURVEYOR RESPONSIBLE FOR SETTING THE MONUMENT.
- ~~4. BRASS DISCS FOR SNOHOMISH COUNTY PROJECTS SHALL BEAR THE COUNTY LAND SURVEYOR'S REGISTRATION NUMBER, AND THE REGISTRATION NUMBER OF THE LAND SURVEYOR RESPONSIBLE FOR SETTING THE MONUMENT.~~

SEE TEXT SECTION 4-03



SNOHOMISH COUNTY PUBLIC WORKS

4-130

MONUMENT CASE AND COVER

APPROVED BY:

COUNTY ROAD ENGINEER

DATE



## CHAPTER 6 - BRIDGES AND BURIED STRUCTURES

### 6-01 GENERAL

#### A. Standards for New Bridges

Except as modified below, new public and private road bridges and associated structures in Snohomish County shall be designed and constructed to meet the minimum requirements set forth in the latest edition, including all interim addenda, of the AASHTO AASHTO LRFD (Load Resistance Factor Design) Bridge Design Specifications and the WSDOT Bridge Design Manual, in that order of precedence.

#### B. Standards for Older Bridges

The AASHTO AASHTO Standard Specifications for Highway Bridges, 17th edition, may be used for the maintenance and rehabilitation design of older, existing public and private road bridges and structures.

#### C. Pre-Design for Private Bridges

Designers of private bridges are encouraged to schedule a pre-design meeting with the Departments of Planning and Development Services and Public Works to discuss design proposals.

#### D. Buried Structures

Buried Structure is a generic term for a structure built or assembled inside an excavation employing embankment or trench methods, which works with granular backfill to derive its support from both the structure and the surrounding soil through soil-structure interaction. Buried Structure types considered herein consist of metal structural plate pipes, arches, and boxes, along with cast-in-place and precast reinforced concrete arch, box, split box, and three-sided structures.

### 6-02 BRIDGE AND BURIED STRUCTURE INFORMATION

#### A. Required Submittals

The following items must be submitted to the Engineer for approval prior to the County accepting a bridge or buried structure that has a span or opening greater than 12 feet. Items 1, 2, and 3 shall be prepared and stamped by a Professional Engineer licensed in the State of Washington.

1. Bridge Load Rating – The load rating shall follow guidance in the current WSDOT Bridge Design Manual.
2. Record Drawings – See EDDS Chapter 10.
3. Hydraulic and Scour Report – At a minimum, the report should include the following items;
  - Basin hydrology evaluation, including the expected range of flows in the waterway.

- Channel hydraulics evaluation, including 100-year flood elevation relative to the bridge elevation and the corresponding maximum expected water velocity.
- Scour evaluation, including soil depth calculation, bridge foundation review, and design of mitigation measures if necessary.
- If situated in a floodplain, verification that a “no-rise” condition exists.

## **B. County Inspections & Acceptance**

Bridges and buried structures in right-of-way or carrying a public road shall be inspected by a County bridge inspector prior to acceptance of the structure. After the above items have been submitted and approved, Snohomish County Public Works will schedule a bridge inspection by a county bridge inspector. Any deficiencies identified must be corrected before acceptance of the bridge. Inspections are performed in accordance with the National Bridge Inspection Standards (FHWA) in conformance with 23 CFR 650 Subpart C.

## **6-03 PERMITS FROM OTHER AGENCIES**

Construction or reconstruction of bridges may require permits from agencies such as the Coast Guard, Army Corps of Engineers, Department of Ecology, or the Department of Fish and Wildlife, among others. It is the project applicant's responsibility to obtain all necessary permits.

### **6-0204 PEDESTRIAN BRIDGES**

Bridges that will carry pedestrian and bicycle traffic shall be designed in accordance with the AASHTO's Guide Specifications for Design of Pedestrian Bridges.

### **6-0305 BRIDGE DESIGN ELEMENTS**

~~— See Standard Drawings 6-010, 6-020, 6-030A and 6-030B~~

#### **A. General Bridge Design Proposals**

- ~~1. Bridge design proposals shall address the elements listed below, as a minimum, for review by the Engineer.~~
- ~~2. The Engineer may direct that other design criteria, such as the bridge rehabilitation criteria set forth in the WSDOT Local Agency Guidelines, be applied under appropriate circumstances.~~

#### **B. Geometrics**

##### 1. Minimum Bridge Widths for Public and Private Roads

~~The bridge roadway shall comprise the full width and configuration of the road being served: travel lanes plus curbs, sidewalks, walkways, bike lanes, and/or shoulders on one or both sides. Accommodation shall be made for utilities, including likely future improvements. See Standard Drawings 6-010 and 6-020.~~

The bridge shall provide for the full width and configuration specified for the functional classification and future use of the road being served. This may include the traveled way plus curb, sidewalks, walkway, bike lanes, and/or shoulder on one or both sides. The bridge traveled-way width, and shoulders if present, shall be measured between curbs or

between faces of rails, whichever is less, but in no case shall it be less than 28 feet for public roads and 20 feet for private roads.

~~1. Bridge width shall be measured between the curbs or between the faces of the bridge railings, whichever is less. The minimum bridge widths shall be the following in order to match the approach road widths:~~

~~2. Public road—28 feet.~~

~~3. Private road—20 feet.~~

~~2. Bridge width shall be measured between the curbs or between the faces of the bridge railings, whichever is less. Accommodations for Utilities~~

Accommodation shall be made for utilities, including likely future improvements.

~~3. Sidewalk Widths for Urban Area Bridges~~

~~4. Urban area bridges shall have a minimum 56-foot wide sidewalk on each side of the roadway. Planter strips are not required. ~~Refer to Standard Drawing 6-010.~~~~

~~4. Separation for Active Transportation Modes~~

~~5. Where operating speeds are 35 mph or higher, and significant bike and/or horseback traffic can be expected, the Engineer may require that facilities for these other modes of travel be separated from the traffic lanes by a bridge rail.~~

~~5. Vertical Clearance Over Roadways~~

~~Overhead vertical clearance for motor vehicles, including overpasses, shall be 16.5 feet minimum.~~

~~6. Vertical Clearance Over Active Transportation Facilities~~

~~6. Vertical clearance above a walkway, sidewalk, equestrian trail or bikeway shall be 10 feet minimum.~~

### **C. Water Crossing Structures**

When a bridge crosses water it shall comply with WAC 220-660-190 (Water Crossing Structures). Deviation from the WAC 220-660-190 will require the approval of the Engineer. The following criteria are part of the WAC 220-660-190:

1. Bridge Height

The design must have at least three feet of clearance between the bottom of the bridge structure and the water surface at the 100-year peak flow unless engineering justification shows a lower clearance will allow the free passage of anticipated debris. Bridge height shall provide at least 3 feet of clearance between the bottom of the deck and the 100-year flood elevation.

7.2. Bridge Abutments

~~8. Span length shall be sufficient so that no in-stream piers are required.~~

~~9. Bridge abutments shall be located well behind the ordinary high water elevation (OHWE) to minimize construction impacts. The waterward face of all bridge elements that~~

may come in contact with waters of the state including abutments, piers, pilings, sill, foundations, aprons, wing walls, and approach fill must be landward of the ordinary high-water line.

#### **C.D. Approach Profile**

##### 1. Sag Vertical Curves

~~1.~~ A bridge shall not be located at the low point of a sag vertical curve to prevent accumulation of stormwater runoff on the bridge.

##### 2. Width & Superelevation

~~2.~~ The width and superelevation of the bridge shall match the approach roadway.

#### **D.E. Load Requirements**

##### 1. Live Loads – Vehicular Bridges

~~1.~~ All vehicular bridges shall be designed to carry a live load of ~~HS-25 (AASHTO Load Factor Design method, LFD) or~~ HL-93 (~~AASHTO~~AASHTO Load Resistance Factor Design method, LRFD) ~~plus a 30% impact load.~~

##### 2. Live Loads – Active Transportation Bridges

Bridges for pedestrian and/or bicycle traffic shall be designed for a live load of 9085 pounds per square foot.

##### 3. Dead Loads

All new bridges shall be designed for actual dead load and superimposed dead loads, such as utilities, pavement and bridge railings.

##### 4. Superimposed Dead Loads - Utilities

~~2.~~The minimum superimposed dead load for ~~The following minimum superimposed dead loads shall be used in design:~~

~~i.~~ Utilities is ~~:-~~ 120 pounds per linear foot, per utility line.

##### 5. Superimposed Dead Loads – Asphalt Overlay

The minimum superimposed dead loads for 2-inch ~~Two-inch~~ asphalt overlays is ~~:-~~ 25 pounds per square foot.

##### 6. All Other Loads

~~ii.~~ All other loads not mentioned shall be per AASHTO LRFD (Load Resistance Factor Design) Bridge Design Specifications and the WSDOT Bridge Design Manual.

~~3.~~ **Bridges for pedestrian and/or bicycle traffic shall be designed for a live load of 85 pounds per square foot.**

#### **E.F. Approach Slabs**

##### 1. Requirements

~~1. Approach slabs are required for all bridges. Approach slab design shall be per AASHTO LFRD (Load Resistance Factor Design) Bridge Design Specifications and the WSDOT Bridge Design Manual. Approach slabs shall be constructed in accordance with Standard Drawings 6-030A and 6-030B, or an approved individual design. The requirement for approach slabs may be waived only by deviation approved by the Engineer based on a geotechnical analysis.~~

## 2. Pavement Seats

~~2. All new bridge plans shall provide pavement seats for approach slabs, unless otherwise approved by the Engineer.~~

## 3. Length & Width

~~3. Approach slabs shall have a minimum length of 10 feet and shall be the full width of the roadway, including curbs, gutters, sidewalks or walkways as applicable. match the bridge width as required in 6-05.B.1, above~~

## **F.G. Piers**~~Substructures~~

### 1. Scour Protection

~~All bridge foundations shall be protected from scour regardless of bridge type, location, and usage.~~

### 2. Scour Analysis

~~A scour analysis is required for new bridges.~~

### 3. Piers

~~1. Piers-Foundations for new bridges shall be located above-landward from the ordinary high water elevation-line and shall be founded on piles or drilled shafts unless it can be demonstrated that there is-will be little-no structural failure from expected scour potentialfor the life of the bridge.~~

### 4. Utility Openings

~~2. Bridge piers and diaphragms shall have openings for existing and future utilities.~~

## **G.H. Decks**

### 1. Threaded Inserts for Utilities

~~1. Bridge decks shall have threaded inserts for existing and future utility installations.~~

### 2. Concrete & Reinforcing Steel

~~2. All-Bridge decks shall be concrete and all reinforcing steel in-concrete bridge decks shall be hot-dip galvanized steel.~~

## **~~6-04~~ SPECIAL REQUIREMENTS**

~~Construction or reconstruction of bridges may require permits from agencies such as the Coast Guard, Army Corps of Engineers, Department of Ecology, or the Department of Fish and Wildlife, among others. It is the project applicant's responsibility to obtain all necessary permits.~~

### **6-0506 GUARDRAILS AND RAILINGS**

~~— See Standard Drawings 6-010, 6-020, 6-040~~

#### **A. ~~General~~ Approach Guardrails**

~~1. Bridge approach guardrails are generally required at all four corners of each bridge. Refer to Standard Drawings 6-010 and 6-020 for typical approach guardrails for urban and rural bridges.~~

#### **B. MASH Compliant**

~~All new bridge railing, rail transitions, and approach guardrail shall be MASH (Manual for Assessing Safety Hardware) compliant.~~

#### **C. Standards and Specifications**

~~2.1. Approach guardrails and bridge railings~~Bridge railing, rail transitions and approach guardrail shall be designed in accordance with the ~~AASHTO~~AASHTO LRFD Bridge Design Specifications, and the ~~WSDOT Bridge Design Manual~~ WSDOT Bridge Design Manual and ~~WSDOT Standard Plans.~~—An acceptable bridge railing option is provided in Standard Drawing 6-040.

~~— Approach guardrails shall be made structurally continuous with bridge railings.~~

#### **D. Hot-Dip Galvanized Steel**

All exposed structural steel in bridge railings shall be hot-dip galvanized steel.

#### **E. Pedestrian Railing Height**

~~3. Pedestrian railing shall be a minimum height of 42 inches measured from the top of the walkway or future overlay.~~