

**Index of Records**

**Project Name      Accessory Apartment Code Update**

<b>Part 1 - DEPARTMENT OF PLANNING AND DEVELOPMENT SERVICES</b>				
<b>Exhibit #</b>	<b>Record Type</b>	<b>Date</b>	<b>Received From</b>	<b>Exhibit Description</b>
1.0001	Public Participation			Parties of Record
1.0002	Project Administration	4/17/2019	Staff	Accessory Apartment Transition Memo
1.0003	Project Administration	7/16/2019	Staff	Project Charter
1.0004	Project Administration	9/25/2019	Staff	Accessory Apartment Policy Options
1.0005	Staff Research			The HART Report 01.06.2020
1.0006	Staff Research	11/19/2020	Puget Sound Regional Council	Regional Housing Needs Assessment - GMPB Presentation
1.0007	Staff Research		American Association of Retired Persons	Accessory Dwelling Units - Model State Act and Local Ordinance
1.0008	Staff Research		accessorydwelling.org	Do accessory dwelling units serve older persons?
1.0009	Staff Research		accessorydwelling.org	Do ADUs cause neighborhood parking problems?
1.0010	Staff Research			Average Apartment Size in the US_Seattle Has the Smallest Rentals
1.0011	Staff Research			Jumpstarting the Market for Accessory Dwelling Units
1.0012	Staff Research		American Association of Retired Persons	The ABCs of ADUs
1.0013	Staff Research			1000 Friends of WA v. Snohomish County
1.0014	Staff Research			Pierce County 18A.37.120
1.0015	Staff Research			Other Codes Tracking Sheet
1.0016	Staff Research			Seattle ADU Legislation_from Mayor Durkan
1.0017	Staff Research			San Juan County_Ordinance No. 12-2007
1.0018	Staff Research			SkagitCounty 14.16.710 Accessory dwelling units
1.0019	Staff Research			Walla Walla_ADU Code Update Information Sheet
1.0020	Staff Research			RCW 43.63A.215
1.0021	Staff Research		Staff	Accessory Apartment Data_Snohomish County
1.0022	Staff Research		Staff	Single Family Dwellings Data_Snohomish County
1.0023	Staff Research		MSRC	MSRC_Accessory Dwelling Unit Guide
1.0024	Staff Research		MSRC	MSRC_Ezample of Local ADU Ordinances
1.0025	Staff Research		American Planning Association	PAS Quick Notes 19 - Accessory Dwelling Units
1.0026	Staff Research			James Nelson et. al. v. San Juan County
1.0027	Correspondence	11/18/2020	Department of Commerce	Submittal-Receipt-Email-2020-S-2032
1.0028	SEPA Documents	3/24/2021	Staff	SEPA Checklist
1.0029	SEPA Documents	3/25/2021	Staff	Accessory Dwelling Units_DNS Postcard
1.0030	SEPA Documents	3/26/2021	Staff	Accessory Dwelling Units_DNS with Signature Block

**\*Contact the Clerk of the Council for copies of Part 1 Exhibits - 425-388-3494 or contact.council@snoco.org**



**Snohomish County**

---

**Planning and Development Services**

3000 Rockefeller Ave., M/S 604  
Everett, WA 98201-4046  
(425) 388-3311  
[www.snoco.org](http://www.snoco.org)

**MEMORANDUM**

**TO:** Inheriting Planner  
**FROM:** Ryan Medlen, Project Manager Priorem  
**DATE:** April 17, 2019  
**SUBJECT:** Accessory Apartment Code Update  
**FOLDER:** S:\Code Dev\Code Projects\Medlen\Accessory Apartments

**Dave Somers**  
*County Executive*

---

**The Project:** This briefing memo is to introduce you to the accessory apartment code and provide you with background information up until this point. The intent is to assist you in taking over the project and avoiding past mistakes.

**Background Information:** The code project is rooted in the need to make the accessory apartment code more practical and to explore options to allow accessory apartments outside the UGA. With some exceptions, County decision-makers are largely thought to be supportive of allowing accessory apartments on substandard lots, including in outside the UGA. There is case law that prevents this from being feasible. To summarize, Growth Management Hearings Board precedent implies that detached accessory apartments contribute toward density whereas attached accessory apartments do not. For this reason, the GMHB would prefer that detached accessory apartments only be permitted on lots 10 acres or larger whereas it is implied that attached accessory apartments are OK on substandard lots.

A version of accessory apartment code amendments were taken to Planning Commission for a briefing in November, 2018 and sent to the PA's Office for review. The PA rejected the code amendments on the basis of the GMHB precedent referenced above. They want to understand the change of circumstance that justifies, under the Growth Management Act, allowing accessory apartments on substandard lots outside the UGA.

The Planning Commission is highly opinionated on the matter. The briefing did not go well in that the discussion descended into fairly repetitive statements that were at times contradictory with the thoughts and comments of other commissioners or other comments from the same commissioner. No consensus was apparent. I would recommend a thorough review of the history of accessory apartments in Snohomish County and the current code requirements of accessory apartments ahead of introducing changes at a briefing. Merging the explanation of the new code amendments with a telling of the current language did not work well. Some of the negativity focused on the current requirements and their perception of these requirements being new.

**Current Issue:** The delay on this project is a result of the introduction of SB 5812 to the Washington State Legislature. The bill has undergone a series of amendments but will likely require the County to make some level of code amendments. Various versions have

included language of varying levels of significance to the substandard lot prohibition. The latest version states accessory apartments cannot be counted toward density inside an urban growth area and that no minimum lot size is permitted (with the implication that this lot size clause only applies to urban areas). One thought is that it seems to be inconsistent logic that accessory apartments do not contribute to density in urban areas, where they are more likely to be marketable as rental properties, but not outside the UGA. If this bill passes, it should be considered whether it implies a legal change of circumstance.

**Thoughts on  
Next Steps:**

Any allowance of accessory apartments on substandard lots outside the UGA is at a high-risk for appeals. There should also be consideration that any appeal may also challenge the County to amend the code to only allow detached accessory apartments on 10+ acre lots outside the UGA.

General thoughts on code amendments:

- An amendment to allow attached accessory apartments on substandard lots outside the UGA should be consistent with GMHB precedent.
- Eliminating the minimum square footage has been well received.
- The owner-occupancy requirement is understood to have limited enforcement abilities and majority management opinion has been to eliminate it. However, the theory of the owner-occupancy requirement was popular with the Planning Commission. Removing the owner-occupancy requirement will be a matter for debate.
- The maximum size will be seen as arbitrary no matter what you propose. Be mindful that accessory apartments are exempt from impact fees.
- Some on the Planning Commission were of the opinion that different types of accessory should have different maximum size (i.e. a basement accessory apartment should be allowed as the entire basement regardless of the size).

# PROJECT CHARTER

Accessory Dwelling Units

<b>Project Title:</b> Accessory Apartment Code Update		<b>Sponsor:</b> Mike McCrary, Deputy Director		<b>Project Manager:</b> Mitchell Brouse, Planner		
<b>Project Description:</b> This project is intended to update the sections of the UDC which pertain to accessory apartment permitting.				<b>Attachment(s):</b>		
<b>Why Is the Project Needed:</b> Accessory dwelling units are often considered a type of housing, which, if cited and regulated appropriately, helps localities achieve some the housing goals identified in the 2015 Comprehensive Plan and 2013 Housing Characteristics and Needs Report. Current UDC code requirements can make pursuing permitting for accessory apartments challenging and impossible for some properties, particularly in the rural zones. Updates to SCC 30.22, 30.28.010, and 30.23.235(3) could improve the usability and flexibility of the regulations, improve clarity, and make construction of accessory apartments more accessible throughout the county.						
<b>Amendment Brief:</b>						
Project Scope		Major Milestone	Target Due Date	Project Organization		
<ul style="list-style-type: none"> <li>Update SCC 30.22 to consider changing accessory apartments from an administrative conditional use to a permitted use in zones where a SFD is allowed.</li> <li>Consider eliminating, changing, or updating the prohibition on accessory apartments on substandard lots listed in SCC 30.23.235(3).</li> <li>Evaluate and consider changes to language in SCC 30.28.010 to simplify regulations, modernize language, and reorder to improve layperson understanding.</li> <li>Evaluate effectiveness of existing regulations.</li> <li>This request will require a SEPA determination including completion of the environmental checklist.</li> </ul>		Revised Project Charter Complete	Aug. 22, 2019	<b>Project Coordination</b> Ordinance development will be lead and coordinated by PDS Long Range Planning staff.	<b>PDS Project Team</b> <ul style="list-style-type: none"> <li>Mitchell Brouse, Planner</li> <li>Brandi Spores, Administrative Assistant</li> </ul>	
		Draft Ordinance Complete	Sept. 2019			
		PDS Review and Testing	Sept. 2019			
		Draft to PA for Review	Oct. 2019			
		Updated Draft	Nov. 2019	<b>Level of Commitment from the PA</b>		
		Planning Commission Briefing	Nov. 2019			
		Planning Commission Hearing	Nov.-Dec. 2019			
		ECAF Transmitted to Council	Dec. 2019-Jan. 2020	This is a proposed code amendment will require substantive involvement from the assigned PA, including consultation, review, and possible risk analysis. As such, it has been given a Tier 3 classification.		
		Council Briefing	TBD			
		Council Hearing	TBD			
Project Scope Change Requirements		Project Deliverables		Outreach Approach		
The scope of the project can be changed at the approval or request of the project sponsor.		<ul style="list-style-type: none"> <li>Project Charter</li> <li>Proposed Amendments and Ordinance</li> <li>SEPA Checklist</li> <li>Staff Report</li> <li>Department of Commerce notice of intent</li> <li>Summary Notice</li> <li>ECAF package for Council consideration</li> <li>Project Record</li> </ul>		<ul style="list-style-type: none"> <li>Planning Commission Hearing</li> <li>SEPA notice and comment period</li> <li>County Council Hearing</li> </ul>		
SOAP Compliance				Key Stakeholders		
The purpose of the Snohomish County Sustainable Operations Action Plan (SOAP) is to integrate sustainable practices that will reduce Snohomish County's carbon footprint. The scope of this project should not be in conflict with the goals of the SOAP.				<ul style="list-style-type: none"> <li>Snohomish County Residents</li> <li>Master Builders Association</li> <li>Snohomish County Permitting Division</li> <li>Tribes</li> <li>Environmental Community</li> <li>Agricultural Board</li> </ul>		

Policy Issues and Project Risks		
	<i>Policy Issue</i>	<i>Risk &amp; Possible Solutions</i>
1	Growth Management Act Compliance	While drafting regulations, care should be taken to ensure that updated code does not violate GMA. There is a perception that allowing accessory dwelling units in the rural area detracts from rural character by allowing urban scale development.
2	Urban vs. Rural/Resource	Should properties located in the rural areas have the same regulations as those properties within the UGAs? In either case, consideration of the specific characteristics of each area is necessary. New regulations should result in development that complies with the specific characteristics of the area.
3	Mobile Homes as Accessory Apartments	Mobile homes are currently allowed as accessory apartments on properties that are larger than 10 acres and located outside the UGAs.
4	Temporary Dwelling Units	SCC has provisions to allow a temporary dwelling units for a relative for up to one year. Consideration should be given into how changing accessory apartment regulations may or may not impact this portion of code and if updates are necessary.

Charter Review/Approval		Date
<b>Prepared By:</b>	Mitchell Brouse, Planner	
<b>Approved By:</b>	Mike McCrary, Deputy Director	

**ACCESSORY APARTMENT CODE UPDATE**

---

**BACKGROUND**

Various Snohomish County planning documents, including the 2015 General Policy Plan and 2013 Housing Characteristics and Needs Report, as well as other planning literature, identify accessory apartments as type of housing that can help diversify the housing stock, increase the supply of affordable and senior housing, better accommodate the shrinking average household size, and help decrease the housing shortage. As such, accessory dwellings units can contribute to achieving the local housing goals listed in the Comprehensive Plan, Countywide Planning Policies, and Multicounty Planning Policies.

This code project is intended to evaluate the role of accessory apartments in implementation of county policy and to update county code accordingly. In late 2018, code amendments were drafted, reviewed by the Prosecuting Attorney, and presented to the Planning Commission. The following is a brief summary of the code amendments proposed at that time:

- a. Change accessory apartments from an administrative conditional use to a permitted use in the rural, resource, and other zones.
- b. Remove the prohibition on accessory apartments on substandard lots.
- c. Remove the minimum accessory apartment size requirements. Simplify the maximum size determination by removing the calculation and setting the maximum size at 900 square feet.
- d. Remove the design and landscaping requirements for accessory apartments in the rural areas.
- e. Clarify language throughout to add clarity and improve usability.

After briefing the Planning Commission, the proposed amendments were tabled to await consideration of SB 5812 by the Washington State Legislature. If approved, it would have affected local regulation of accessory dwelling units. The proposed bill did not pass, and thus, this is an opportune time to reconsider updates to these sections of code.

---

**PROBLEM STATEMENT**

Existing code regarding accessory apartments is somewhat difficult for land owners to use and presents regulatory barriers for those seeking permits to construct accessory apartments, especially in the rural and resource zones. Between 2013 and the end of 2018, 70% of accessory apartment applications have been located in the rural areas and, while the regulations on paper are the same for both urban and rural areas, in practice, they restrict ADUs in the rural zones to a greater extent than in the urban zones. For example, because required lot sizes are larger in the rural and resource zones than the urban zones, the accessory apartment prohibition on substandard lots affects rural properties to a greater extent than urban properties.

Code updates that improve clarity, reduce regulatory barriers, and make it easier for land owners in the rural areas to obtain permits could be warranted. Updates could be pursued while maintaining protections on health, safety, and welfare, limiting sprawl, and protecting the character of rural areas.

---

**DESIRED OUTCOME**

The following are the primary goals of this code update project:

- a. Improve the clarity and usability of SCC sections that apply to the construction and use of accessory apartments.
- b. Reduce barriers to accessory apartment construction, with particular focus on the rural zones.

- c. Evaluate current accessory apartment development standards to ensure that they serve their intended purpose. Pursue updates to code if determined necessary by this analysis.
- 

## OVERVIEW OF EXISTING CODE

Development standards for accessory apartments are contained in SCC 30.28.010. Other applicable sections include the use tables (SCC 30.22), general development standards for substandard lots (SCC 30.23.235, and definitions (SCC 30.91A.040, 30.91A.050, and 30.91L.195). Appendix A contains full text of applicable code sections. The following is a summary of code that directly apply to accessory apartments:

- Accessory apartments are an administrative conditional use in all zones that single family dwellings are allowed.
  - Accessory apartments are prohibited on substandard lots.
  - Either the primary single family dwelling or the accessory apartment shall be owner occupied and the owner shall file and record a declaration of owner occupancy.
  - Accessory apartments shall be no smaller than 360 square feet. Maximum square footage of the accessory apartment is a percentage of the square footage of the primary dwelling. The percentage changes dependent on the size of the primary dwelling.
  - Attached accessory apartments shall preserve the architectural character of the single family dwelling. Only one main entrance allowed on the front of the building.
  - All accessory apartments shall comply with the setback and lot coverage requirements in the zone for which they are located and detached accessory apartments shall not extend beyond the front of the single family dwelling, unless they are appropriately screened, in residential, multiple-family, or commercial zones.
  - One off-street parking spot shall be provided.
- 

## GROWTH MANAGEMENT ACT (GMA) CONSIDERATIONS

The Growth Management Act (GMA) sets limits on development in an effort to avoid sprawl. As such, it prohibits urban development in areas that are identified as rural and resource, requiring that development policies in those areas maintain the “rural character” of the area. While “rural character” is not explicitly defined, the GMA, Growth Management Hearing Board (GMHB) decisions, and Supreme Court rulings provide a framework for determining rural character and how it interacts with accessory apartment regulations:

- The state legislature did not, in the GMA, specify a specific density threshold that can be used to differentiate between urban and rural, but it did provide a framework for making that determination.
  - Rural density is “not characterized by urban growth” and maintains consistency with “rural character.”
  - As such, rural densities can/should be determined, based on the specific characteristics of the area.
- In general, GMHB decisions indicate that development density over 1 dwelling unit per 5 acres is not considered rural. This bright line test has been used in a variety of GMHB opinions.
- Further, attached and detached accessory apartments are considered differently with regard to density. Detached units need to be considered in density calculations, while attached units, due to their close association with the primary dwelling, do not need to be considered.
- Despite GMHB decisions on rural densities, the Supreme Court of Washington stated in Thurston County v. WWGMHB that the GMHB does not have the authority to establish a bright line test and that the hearing board should make determinations about rural densities based on the specific attributes of the case.

**POLICY OPTIONS AND CONSIDERATIONS**

Growth Management Hearing Board decisions and the application of the GMA need to be analyzed to inform how accessory apartment regulations can be structured. With that in mind, care should be taken to ensure that regulations do not allow urban population densities in the rural areas. Further, it should be noted, and considered while making policy decisions, that impact fees do not apply to the development of accessory apartments. Tables 1 and 2, below, outline a two key policy decisions that will provide direction to the development of code amendments for accessory apartments and Table 3 outlines other code revisions that could be considered.

**TABLE 1: Policy Decision Number 1**

<b>Current Regulation</b>			
Accessory apartments (AA) are an administrative conditional use in all zones that allow single family dwellings (SFD).			
<b>Code Options</b>		<b>Key Considerations</b>	<b>Rationale</b>
<b>All Zones</b>			
1	Keep AAs an administrative conditional use in all zones that allow an SFD.	Maintain the similar application procedures as are currently in place.	Current code allows AAs on all standard lots as an administrative CUP, changing this may require evaluation of allowing AAs in some areas.
<b>Rural and Resource Zones</b>			
2	Change AAs to a permitted use in the rural and resource zones that allow an SFD.	<ul style="list-style-type: none"> <li>• Would setting a limit on the number of permits that can be issued for detached AAs be appropriate?</li> <li>• Should other regulations be crafted to ensure that all AAs are related to the primary structure?</li> </ul>	Attached AAs are generally not considered dwelling units for density calculations. Regulations for detached units should ensure that the AA is in close association with the primary dwelling, and findings should demonstrate that the resulting development meets the required “rural character”. E.g. San Juan County ADU regulations.
3	Change AAs to a permitted use in the rural and resource zones that allow SFDs. Allow only detached AAs in the rural area on lots that are 10 acres or larger and allow only attached AAs on lots of less than 10 acres.	Could be the cleanest method to ensure that accessory apartments are not used as a way to establish urban development in the rural areas, while maintaining the option for rural land owners to construct an AA.	Maintains a 5 acres per detached unit density, which is the threshold used by the GMHB. Allows attached units on all standard rural lots.
<b>Urban Zones</b>			
4	Change AAs to a permitted use in the urban zones that allow an SFD.	<ul style="list-style-type: none"> <li>• How are other regulations, such as parking and design, are enforced and reviewed if there is not a CUP process?</li> <li>• What is the value to public health, safety, and welfare of requiring a CUP?</li> </ul>	GPP Goal HO 3 is states that regulations should contribute as little as possible to housing costs. Additional permitting and time can contribute to costs.



**TABLE 2: Policy Decision Number 2**

<b>Current Regulation</b>		
Accessory apartments are prohibited on substandard lots in all zones.		
<b>Code Options</b>	<b>Key Considerations</b>	<b>Rationale</b>
1	Maintain the prohibition of AAs on substandard lots as it is currently included in code.	Because of required lot sizes, the prohibition on substandard lots affects properties in the rural areas to a greater extent than lots in the UGAs.
2	Maintain prohibition of AAs on substandard rural lots only.	Rural character needs to be maintained in the rural areas. Residential density is a part of that, and past decisions of the GMHB have indicated that 5 acres per dwelling unit constitutes rural densities.
3	Eliminate the prohibition to allow AAs on any substandard lot with a SFD.	Similar to considerations in policy decision 1, if this policy is pursued, findings should establish that the resulting development does not violate the GMA by allowing urban densities in the rural areas.
4	Eliminate the prohibition for attached AAs on substandard rural lots while maintaining a prohibition of detached units.	Allowing attached AAs on substandard lots will accommodate a variety of rural land owners, while maintaining the “rural character” of the area.
5	Eliminate the prohibition on attached AAs on substandard lots in both urban and rural areas while maintaining the prohibition on detached AAs on substandard lots in both urban and rural areas.	Similar to number 3 above, this option would allow attached AAs on all substandard lots.

**TABLE 3: Other Code Updates**

Desired Outcome	Primary Change	Details/Other Notes
Improve code clarity and usability.	Update definitions	One clear definition of “accessory apartment” with two simple definitions of “attached” and “detached”. The primary difference between the two is that they are either connected to a primary dwelling or not. Language should be clear and explicit as to what it means to be “attached”.
	Update and simplify accessory apartment maximum and minimum size restrictions listed in SCC 30.28.010(3).	a. Eliminate minimum size requirement; <b>AND</b> b. Update maximum size restrictions to a maximum square footage and percentage of the SFD, whichever is smaller. The combination will help ensure AAs are in close association with the primary SFD.
	Move parking requirements to SCC 30.26 General Development Standards - Parking.	This change will add consistency with the rest of the code, keeping all parking regulations in the same code section.
	Reorder and rewrite language as necessary to improve code flow and understandability.	
Remove regulatory barriers for accessory apartments in the rural area.	Exempt AAs in the rural zones from landscaping and design standards in SCC 30.28.10(4), 30.28.010(5), and 30.28.010(6).	Lots in the rural area are generally larger and often have a mix of building types without uniform neighborhood design. Design requirements are not as important in these cases.
Evaluate other regulations and consider changes that will add flexibility to the siting of attached and detached AAs.	Evaluate the need to maintain residency restrictions, which require one of the two units to be occupied by the owner.	Some jurisdictions are eliminating this requirement and allowing both the ADU and the primary residence to be renter occupied.
	Assess the parking requirements to determine if a reduction is appropriate.	Some jurisdictions are decreasing or eliminating parking requirements for ADUs. Additionally, GPP Policy HO 3.B.2 states that the county should consider reducing parking requirements where there is access to public transportation. It may be appropriate to have differing parking requirements in the rural and urban areas.
	Consider allowing reduced setbacks for detached AAs and providing exceptions from lot coverage requirements for AAs.	Particularly in the urban zones, where lots are smaller, setback and lot coverage regulations can create difficulty with siting AAs. Some other jurisdictions are loosening these requirements for ADUs while others are exempting them entirely.
	Consider allowing more than 1 AA on standard lots in the urban areas.	Similar to other options above, some jurisdictions are allowing more than one ADU per lot as a method of increasing density in single family neighborhoods, diversifying housing stock, and creating additional lower cost housing units.
Use AAs as a method to help achieve housing goals.	Do not allow AAs to be used as a vacation rental.	The City of Santa Cruz has done this. They state: “...the ADU is intended to provide long-term housing for a household member, family, or tenant.”

# HART

## Report and Five-Year Action Plan

Published January 2020



  
*Snohomish County*

**HOUSING AFFORDABILITY  
REGIONAL TASKFORCE**

# TABLE OF CONTENTS



<b>ACKNOWLEDGEMENTS</b> .....	3
<b>EXECUTIVE SUMMARY</b> .....	6
<b>INTRODUCTION</b> .....	9
<b>HART’S PROCESS</b> .....	11
Initial Work: Getting Grounded in the Data; Definitions and Process.....	11
Next Phase: Narrowing and Framing; Engaging Partners.....	13
Finishing up: Confirming the Action Plan items and reviewing this Report.....	14
<b>THE CHALLENGE</b> .....	16
Housing Affordability is Declining.....	16
Low-Income Housing is Being Lost to Redevelopment and Resale.....	19
Housing Demand Driven Primarily by Population Growth.....	19
Housing Supply is Not Keeping Pace with Population Growth.....	21
The “Missing Middle”.....	22
Social Equity Implications.....	23
<b>WHERE DO WE GO FROM HERE?</b> .....	24
Local Government’s Role in Addressing Housing Affordability.....	24
Framework Goals for the Action Plan.....	25
<b>PURPOSE AND EXPECTATIONS</b> .....	28
<b>HART’S 5-YEAR HOUSING AFFORDABILITY ACTION PLAN</b> .....	29
Early Action Items.....	30
Five-Year Action Items.....	33
<b>CONCLUSION</b> .....	44
<b>APPENDIX</b> .....	45
Attachment A: Summary of HART’s Five-Year Action Plan.....	45
Attachment B: Infographics.....	51

# ACKNOWLEDGEMENTS



## HART Members & Alternates

### Chair

Dave Somers, Snohomish County Executive

### Co-Chair

Nicola Smith, City of Lynnwood Mayor

### City of Arlington

Barb Tolbert, Mayor  
Marc Hayes, Community & Economic  
Development Director

### City of Bothell

Tom Agnew, Councilmember  
Liam Olsen, Councilmember

### City of Edmonds

Dave Earling, Mayor  
Shane Hope, Development Services Director

### City of Everett

Cassie Franklin, Mayor  
Nick Harper, Deputy Mayor

### City of Granite Falls

Matt Hartman, Mayor  
Brent Kirk, City Manager

### City of Lynnwood

Nicola Smith, Mayor  
Art Ceniza, Assistant City Administrator

### City of Marysville

Jon Nehring, Mayor  
Gloria Hirashima, City Administrator

### City of Mill Creek

Brian Holtzclaw, Mayor Pro Tem  
Stephanie Vignal, Councilmember

### City of Monroe

Geoffrey Thomas, Mayor  
Ben Swanson, Community Development  
Director

### City of Mountlake Terrace

Kyoko Matsumoto-Write, Mayor  
Bryan Wahl, Councilmember

### City of Mukilteo

Jennifer Gregerson, Mayor

### City of Snohomish

John Kartak, Mayor  
Steve Dana, Councilmember

### City of Stanwood

Leonard Kelley, Mayor

### Snohomish County

Dave Somers, Executive  
Nate Nehring, Councilmember  
Stephanie Wright, Councilmember  
Yorik Stevens-Wajda, Legislative Analyst

### Town of Darrington

Dan Rankin, Mayor

### Town of Woodway

Mike Quinn, Councilmember  
Brian Bogen, Councilmember



## Workgroup Participants

### **Alliance for Housing Affordability**

Chris Collier

### **City of Bothell**

Mike Kattermann

### **City of Everett**

Allan Griffen  
Becky McCrary

### **City of Lynnwood**

Ashley Winchell  
Julie Moore

### **Cocoon House**

Joe Alonzo

### **Community Services Advisory Council**

Jennifer Bereskin-Delia  
Mindy Woods

### **Compass Health**

Tamera Loesch

### **DevCo, LLC**

Jack Hunden

### **Domestic Violence Services**

Vicci Hilty

### **Everett Gospel Mission**

John Hull

### **Everett Housing Authority**

Ashley Lommers-Johnson  
Tony Nabors

### **Helping Humanity USA**

Brenda Bolanos-Ivory

### **Homage Senior Services**

Steve McGraw

### **Homes and Hope Community Land Trust**

Kim Toskey

### **Housing Authority of Snohomish County**

Janinna Attick  
Kristen Cane  
Duane Leonard

### **Housing Consortium of Everett and Snohomish County**

Mark Smith

### **Housing Hope**

Fred Safstrom

### **Interfaith Association**

Jim Dean

### **Mercy Housing**

Bill Rumpf

### **Pioneer Human Services**

Joseph Nagel

### **Realtor's Association**

Cami Morrill

### **Snohomish County Council**

Nicole Gorle

### **Snohomish County Executive Office**

Alessandra Durham\*  
Kent Patton\*

### **Snohomish County Facilities Management**

Cherie Hutchins



## Workgroup Participants cont.

### **Snohomish County Human Services**

Jackie Anderson\*  
Kelsey Bang-Olsen\*  
Mary Jane (MJ) Brell Vujovic\*  
Tina Ilvoen  
Ken Katahira  
Nate Marti\*

### **Snohomish County Planning and Development Services**

Barb Mock\*

### **Snohomish County Public Works**

Randy Blair  
Brook Chesterfield

### **Snohomish County Transportation Coalition**

Marianna Hanefeld

### **U.S. Representative Rick Larsen**

Lindsey Webb

### **YWCA Seattle | King | Snohomish**

Mary Anne Dillion

## Lead Staff

### **Snohomish County**

Jackie Anderson  
Kelsey Bang-Olsen  
Robei Broadous  
Mary Jane (MJ) Brell Vujovic  
Alessandra Durham  
Tina Ilvoen  
Ken Katahira  
Nate Marti  
Wendy Roullier

## Facilitator

### **Karen Reed Consulting, LLC**

Karen Reed

---

\* Convener of Workgroups

# EXECUTIVE SUMMARY



The advantages of a strong economy and beautiful natural environment have long drawn new residents to our region. New residents make our communities more vibrant and create more opportunity for all. Our advantages have also resulted in challenges. After decades of population growth, the pressures on our housing market are particularly visible.

The rate at which housing units are being constructed in Snohomish County is simply not keeping pace with our growth in population, and most of the housing coming online is unaffordable to those at moderate- or low-incomes. Today, a third of the households in Snohomish County are “cost burdened”—they pay more than thirty percent of their income on housing and utilities. These households exist at all income levels. A third of all Snohomish County households are low-income, which we define as households earning 60% or less of Area Median Income: housing affordable to these families will generally not be produced without some type of government intervention or subsidy.

Despite this, we see examples of progress. Local nonprofit and government housing agencies are creating and preserving housing affordable to low- and moderate-income households in several communities across Snohomish County. The state legislature has granted cities and counties more tools and revenue options to respond to the need for greater housing affordability. Partners are sharing ideas and experience all across our region. As local government acquires more knowledge and tools to respond to the challenge of housing affordability, the pressure for us to do so is growing.

The Snohomish County Housing Affordability Regional Taskforce (HART) was created by County Executive Dave Somers to bring together elected leaders from cities across Snohomish County and the County Council, on the belief that the housing affordability challenge before us is intensifying, and is best addressed collaboratively and proactively.

## HART'S MISSION

*Collaboratively develop a five-year action plan that identifies priorities for county and city governments to accelerate our collective ability to meet the housing affordability needs of all Snohomish County residents and set a foundation for continued success through 2050*





This report sets forth recommendations to our fellow city and county officials in Snohomish County in the form of a **Five-Year Housing Affordability Action Plan (Action Plan)**. The Action Plan includes what we believe are the most promising steps for local governments to pursue now and over the next few years.





## 2020 Early Action items include:

1. *Encouraging cities to enter into cooperation agreements with the Housing Authority of Snohomish County (HASCO) and Everett Housing Authority.*
2. *Implementing the state sales tax shift to local governments for up to 20 years to fund low-income housing authorized by HB 1406, and adopted by Legislature in 2019.*
3. *Lobbying for changes in state and federal law that will enable more consolidated and streamlined funding to support low-income housing.*
4. *Reviewing and considering recommendations from existing toolkits to engage communities around the issue of housing affordability.*
5. *Fostering community conversations about density.*
6. *Engaging private sector stakeholders – large employers, others – in helping to find solutions to our housing affordability challenge.*
7. *Confirming and supporting an ongoing structure for regional collaboration around production of housing affordable across the income spectrum.*
8. *Tracking progress on the Action Plan.*

HART began its work in May of 2019. The effort was informed by more than forty local partners who provided us with their insights and recommendations as to the ways local government can help support housing affordability across the income spectrum. Our Action Plan is a first step. HART plans to continue this work in 2020 and we want our Action Plan to evolve over time as we learn from future experience and consider new approaches and solutions.

The challenge of housing affordability is not about “other people.” It is a problem facing our own families and friends; our grown children trying to make it on their own; our neighbors; people we interact with every day as we shop, pick up our kids from school, take an aging parent to the doctor, or join in community events. The good news is there is ample evidence—real examples throughout Snohomish County, the Puget Sound, and nationally—that we can maintain and evolve vibrant, welcoming, livable, safe communities at the same time as we work to meet the housing affordability needs of all our residents.

Through collaboration among city and county government officials in Snohomish County, we can make progress on housing affordability. The problem is urgent and becoming more critical each year. We hope each City Council and the County Council will consider the items in our Action Plan and take steps in 2020 and each year thereafter to address this challenge and ensure a better future for our communities.

# INTRODUCTION



The advantages of a strong economy and beautiful natural environment have long drawn new residents to our region. New residents make our communities more vibrant and create more opportunity for all. Our advantages have also resulted in challenges. After decades of population growth, the pressures on our housing market are particularly visible. We have all seen lower priced housing in our communities torn down and replaced by higher priced development. Headlines about rapidly escalating home prices are a daily feature of life here. We wonder who can afford these high-priced homes and what happened to those families that moved out. We hear from our children's teacher, our bank teller, our local firefighters about how far they drive every morning to get to their jobs because the nearest home they can afford is many miles and half a dozen cities away.

Despite this, we see examples of progress. Local nonprofit and government housing agencies are creating and preserving housing affordable to low- and moderate-income households in several communities across Snohomish County. Many of our cities have implemented multi-family tax exemption programs to incentivize construction of new apartments, or have zoning in place to allow accessory dwelling units in single-family zones. The state legislature this year enacted new funding and other options as well as mandates for local government to respond to the housing challenge.

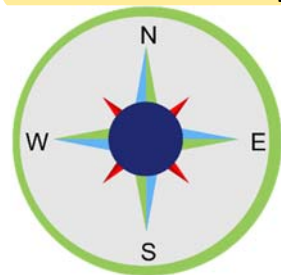

Partners are sharing ideas and experience all across our region. As local government acquires more knowledge and tools to respond to the challenge of housing affordability, the pressure for us to do so is growing. Local elected officials have long grappled with the challenges of growth. The State Growth Management Act<sup>2</sup> (GMA), enacted in 1990, charged local government to plan for addressing a variety of quality of life issues in the face of rapid population growth including: ensuring housing is available at a full range of affordability; preserving agricultural land and rural areas; providing open space and recreation opportunities; ensuring transportation system development is coordinated—and more.<sup>3</sup> Perhaps one of the most challenging goals of the GMA has been ensuring housing affordability. Population growth has exacerbated demand for housing and the housing supply pipeline has simply not kept pace. Making matters more challenging, local government efforts to respond to housing affordability challenges—whether by considering approval of new multi-family zones or permitting new housing projects affordable to those with very limited incomes—are often subject to strong pushback by community members.

The Snohomish County Housing Affordability Regional Taskforce (HART) was created by County Executive Dave Somers to bring together elected leaders from cities across Snohomish County and the County Council on the belief that the housing affordability challenge before us is intensifying and is best addressed collaboratively and proactively.

<sup>2</sup> Chapter 36.70A RCW.

<sup>3</sup> GMA's thirteen planning goals are set forth at RCW 36.70A.020.



Our mission is to *collaboratively develop a five-year action plan that identifies priorities for county and city governments to accelerate our collective ability to meet the housing affordability needs of all Snohomish County residents and set a foundation for continued success through 2050.*

A lack of housing affordability impacts residents *at all income* levels in Snohomish County. HART seeks to alleviate this challenge for *all residents*. We define housing affordability in a manner commonly used both regionally and nationally. Specifically, ***housing is considered affordable to a household if no more than 30% of that household's income is spent on housing costs including utilities.*** This is a simple metric, applicable at all household income levels.

A household is considered "**cost-burdened**" if it ***pays more than 30% of its income on housing and utilities.***

When we refer in this report to "**housing affordability**" we mean housing that can be rented or purchased by a household *without being cost-burdened*. This is a challenge for Snohomish County households across the entire income spectrum. But there are greater challenges for households at lower income levels: without direct government support or incentives, the private sector housing market is unable to deliver housing affordable to households making less than 60% or below of Area Median Income (AMI). Government incentives are needed in some markets to ensure creation of housing affordable to those making 80% or less of AMI.

In this report, when we refer to "**low-income housing**" we are referring to housing affordable to ***households at 60% or less of AMI.*** Fully **one-third** of households in Snohomish County are low-income by this definition.

This report sets forth recommendations to our fellow city and county officials in Snohomish County, in the form of a **Five-Year Housing Affordability Action Plan (Action Plan)**. The Action Plan includes what we believe are the most promising steps for local government action over the next few years. The Action Plan includes eight (8) "Early Action" items, and 37 other action items to support 5 framework goals. The Action Plan is presented in the body of this report and is summarized in **Attachment A**.

The Action Plan is the starting point for a much longer journey. It should evolve over time as we learn from our experiences and adapt to our community's needs. We are recommending annual reviews of progress and consideration of new ideas. The Action Plan is premised on the understanding that while each of our communities is unique, if we adopt a common commitment to promote housing affordability, we will collectively be better positioned to meet this challenge. We hope our Action Plan will spark increased engagement on housing affordability by every city council and the Snohomish County Council.

In the following sections, this report outlines HART's process, describes the housing affordability challenge, and the role of cities and the county in responding to that challenge. Finally, our Action Plan is presented.



# HART'S PROCESS



HART was launched by Snohomish County Executive Dave Somers in the spring of 2019. All mayors were invited to participate, as were representatives from the County Council, and Tribal nations. Ultimately, we had active participation from 14 of 20 cities, two County Councilmembers, and the County Executive.<sup>4</sup> Most members had a designated alternate, either another elected official or senior staff member. We elected Executive Somers and Lynnwood Mayor Nicola Smith to serve as HART's Co-Chairs. We were supported by a team of county staff and an independent facilitator. Our first meeting was on May 31, and we met eight times between May 2019 and January 2020.

HART's meetings were open to the public, and all our meeting agendas, minutes, and materials are posted online at <https://snohomishcountywa.gov/5422/HART>.



We provided a means for interested parties to provide written comments to HART (either at meetings or online); all comments received were shared with HART.

HART's process has provided each of us with additional education on the subject of housing affordability. We have heard from over forty partners, reviewed dozens of local, regional and national reports, and deliberated on over a hundred concepts to promote housing affordability. Although the voting members of HART are all elected officials or their representatives, we sought to maximize input from experts on housing affordability issues and we are deeply grateful for their commitment to sharing their knowledge and advice with us. They have greatly informed our thinking.

## Initial Work: Getting Grounded in the Data; Definitions and Process

At our first meeting on May 31, 2019, we quickly affirmed that housing affordability is an extremely important issue for nearly all our communities. We further identified **three core challenges** which became the foundation on which we built our work:

- What **policy and regulatory** actions will help?
- What **funding options** are available?
- How can we be more effective at **community outreach and engagement**?

<sup>4</sup> As the tribal governments did not elect to participate, our recommendations here are directed to County and city governments.



We affirmed that our mission statement is not limited to consideration of low-income housing (as defined above—housing affordable to households making 60% or less of AMI), rather, we wanted to identify recommendations supporting housing affordability *at all income levels, for all our residents*. As set forth above, housing is considered affordable to a household if that household pays no more than 30% of its income on housing including utilities.

Our first three meetings served to develop a common understanding of the housing affordability challenge in Snohomish County. We heard from many local partners including private for-profit developers, realtors, and nonprofit and governmental housing developers and operators. We asked them to share with us *what they need from local government to be successful*. These were informative presentations, highlighting many common themes. We also heard from local government planners about the primary activities of cities and the County in supporting housing affordability, including local accomplishments and challenges. Snohomish County staff provided HART with numerous reports on housing affordability, including taskforce reports from neighboring counties, toolkits, and reports from a variety of agencies.

We adopted rules to guide our process. Each member of HART had one vote. Our goal was to reach a collaborative consensus on what to recommend to our fellow local government officials. Under our rules, **recommendations** included in this report had to be supported by not less than **60% of us voting**, and **consensus support** required support of at least **75% or more** of us voting on an issue. This final report required the approval of 60% of us in number. We agreed that short minority statements could be submitted by any HART

members in strong opposition to any aspect of this report.

Our initial meetings generated over one hundred ideas to increase housing affordability in Snohomish County. The ideas came both from local stakeholder presentations and the reports from other agencies. Concepts were sorted into three categories, matching the three core challenges first identified:

- Policy and regulatory actions;
- funding options;
- outreach and community engagement.

Staff then created a “screening ballot” for us incorporating all the ideas on the table. The purpose of the ballot was to determine which ideas we collectively saw as most promising for further consideration.

We reviewed the screening ballot at our third meeting and each of us independently filled it out after the meeting.

We were asked to rate each concept on a scale of 1 to 5, with 5 being “potentially very promising, we should definitely explore further”; 3 being “open to exploring/neutral”; and 1 being “extremely problematic (politically and/or operationally), not a good use of time to explore further.”





## Next Phase: Narrowing and Framing; Engaging Partners

We reviewed the combined results of the initial screening ballot at our fourth meeting. Approximately half of the concepts reviewed (about fifty in total) received an overall average support rating of 3.5 or higher on a scale of one to five. We agreed to forward all of the highly rated ideas for further review. We also voted to add a handful of additional items that, while not highly rated in the screening exercise, were considered by a majority of us to be important to continue to explore. We agreed to create three stakeholder workgroups—one around each of the three core challenge areas. The workgroups were asked to provide us additional information on each of the highly rated concepts using a common briefing template. Our staff team reached out to a wide array of agencies and partners and asked for volunteers to serve on these stakeholder groups. We were gratified by the response: over forty individuals agreed to participate in the workgroups. HART also invited each workgroup to submit additional templates for ideas that they felt were important for us to consider but did not receive a high rating from HART members.

The briefing template used by the workgroups sought the following information for each concept in three pages or less:

- Potential impact on housing affordability challenge (high/medium/low)
- Ease of implementation (easy/moderate/difficult)
- Is the idea targeted to increase housing demand or supply?  
What income level(s) are assisted?
- Does the concept promote housing preservation or construction?
- Is it about advocacy or community engagement?
- Where, geographically, would the idea be most effectively applied?  
Countywide? Specific locations?
- Implementation steps, supporting tactics and strategies
- Community engagement considerations
- Suggested lead agency and key partners

The workgroups deliberated over the last half of the summer, from late July through early September. They combined similar ideas into single templates and incorporated a handful of new ideas into their work that we had not forwarded. They delivered 46 templates to us, over 150 pages in total. Many of the templates addressed multiple related concepts.

Each template is available online at [www.snohomishcountywa.gov/5425](http://www.snohomishcountywa.gov/5425) in the documents included in meeting number five. We highly commend the workgroups for the information they provided us and we encourage all our peers to review these briefings.<sup>6</sup>

Our fifth meeting was dedicated to hearing from the workgroups. The presentations focused on thematic priorities and were extremely helpful in shaping our thinking about the Action Plan. At this same meeting, we discussed and identified five proposed framework goals to shape the Action Plan. We were very fortunate to have the opportunity to then share our initial findings and these proposed framework goals with other local elected officials at the Snohomish County

<sup>6</sup> Most, but not all of the ideas briefed in the templates are included in the Action Plan.



Tomorrow (SCT) Annual Assembly on September 25<sup>th</sup> which was dedicated to the subject of housing affordability.

## Finishing up: Confirming the Action Plan items and reviewing this Report

Our sixth meeting focused on reviewing the input from SCT attendees. Comments received confirmed general support for our framework goals and offered many ideas for how to pursue these goals, several of which are included in our Action Plan. We then discussed in more detail the structure for the Action Plan and previewed a second screening ballot, which sought our recommendations as to:

- What concepts should remain in the 5-Year Action Plan and which should be removed?
- Are there “Early Action” items we should pursue in 2020?
- Are there proposals to call out for “Joint Action” pursuing either as a single, unified strategy, or in alignment through individual jurisdiction action?
- How strongly do we support each item?

We completed the second screening exercise independently. When we reconvened for the seventh meeting on November 7, 2019, we reviewed the combined results and, through an extended discussion and series of votes, made several adjustments to the list of items to be included in the Action Plan. We found that we

shared overwhelming support to retain nearly all the concepts under discussion in the Action Plan and agreed to consolidate closely related items where appropriate. We also identified a set of eight “Early Action” items we agreed should be launched in 2020.

There were three exceptions to this strong support, items on which we were divided: (1) supporting mandatory inclusionary zoning activity; (2) moving the urban growth boundary; and (3) exploring a regional housing levy. There were strong advocates on both sides of these three issues, particularly the last two. We want to describe briefly below the core points made in multiple HART meetings regarding moving the urban growth boundary and proposing a regional housing levy.

First, with respect to moving the urban growth boundary, several HART members believed that this would be an important step for housing affordability by making more land available for housing. On the other side, several members felt that such newly available land would likely be in areas at the outer edges of the urban area, would be converted to high end single-family homes, and would exacerbate the congestion on our roads as those homeowners would be likely to commute to far-away job centers.

The question of a regional housing levy also had strong support and opposition. There were members who observed that an additional property tax levy would add additional cost burden to all households and were not inclined to support exploring this type of tax measure. Others noted that they believed a levy was the biggest step the county residents could take to inject significant new funds into the construction of low-income housing, that levy proceeds could be highly leveraged by other dollars, and that we had identified relatively few funding measures in





the Action Plan. HART agrees that new funding is needed in order to be able to significantly expand the supply of low-income housing. The Action Plan includes recommendations to explore additional funding sources for low-income housing and to jointly advocate in support of additional funding from the state and federal government.

About a month before our eighth and final meeting, we were each sent a draft version of this report and the Action Plan for review and comment. Our last meeting confirmed direction to finalize this report and the Action Plan.



# THE CHALLENGE



## Conditions Impacting Housing Affordability in Snohomish County

Before presenting the Action Plan, it is important to outline the housing affordability challenge we face. This challenge is most simply explained through the basics of demand and supply and how the mismatch between them impacts housing affordability.

### Housing Affordability is Declining

What we have been experiencing for several years is the inability of the housing market to create housing units either in number or at a price that are affordable to most of the households in Snohomish County. As noted in the introduction to this report, we define housing affordability based on the percentage of income a household pays for housing costs including utilities. Housing is considered “affordable” if the household living in (or seeking to rent/buy) a home is paying no more than 30% of their income on housing costs including utilities. Those paying more than this 30% are “cost-burdened.” Households at all income levels may be cost-burdened, but for those with less income the trade-offs between paying for housing and other essentials—food, medicine, transportation—become more dire.

The U.S. Census Bureau estimates that ***in 2018, some 98,999 households in Snohomish County — thirty three percent (33%) of all households — were paying 30% or more of their income on housing costs.***<sup>7</sup> Households at lower income levels are much more likely to be “cost-burdened.” Despite considerable attention being drawn to housing issues, affordability has significantly worsened in recent years. Growth in income has greatly lagged the growth in housing costs. Data for Snohomish County from 2010 and 2017 illustrates this, as shown in the table below:

<b>Snohomish County, WA</b>			
	<b>2010</b>	<b>2017</b>	<b>% Increase</b>
<b>2-bedroom apartment rent</b>	\$ 901	\$ 1,347	49.5%
<b>Average single-family home price</b>	\$400,000	\$544,449	36%
<b>Median household income</b>	\$ 66,300	\$ 78,020	17.7%

Rent Reasonableness Survey, Dupree and Scott;  
U.S. Census Bureau American Community Survey 2013-2017

<sup>7</sup> U.S. Census Bureau, American Community Survey, Table S2503, 2018 1-Year Estimate



Renters are particularly impacted by the housing affordability challenge. Renters in our county tend to be of lower income than homeowners: 48.2% of renters (versus 29.5% of homeowners) made less than \$75,000 in household income in the last year.<sup>8</sup> As a result, renters on average experience a higher incidence of being cost-burdened than home-owners. An estimated 95,045 Snohomish County households are renters—a third of all households in the County.<sup>9</sup> In 2019, fair market rent for a two-bedroom apartment averaged \$1,899 per month in Snohomish County. To afford that and pay no more than 30% of their income on housing and utilities, a household would need to make \$36.52 an hour, or \$75,960 a year. **This means that nearly half (48.2%) of all households in Snohomish County cannot afford an average two-bedroom apartment offered at fair market rent.** Those making minimum wage (\$12/hr.) would need to work three full-time jobs to afford an average two-bedroom apartment in Snohomish County.

The challenge goes beyond our neighbors making minimum wage. Residents in most types of occupations struggle with housing costs in Snohomish County. Bank tellers, retail clerks, firefighters or police officers, construction workers, community and social service workers, to name a few, typically cannot afford a two-bedroom apartment in Snohomish County without spending more than 30% of their income towards housing. In fact, out of the total 25 occupation categories reviewed by the U.S. Census Bureau, only five (5) of them had median annual earnings high enough to afford a 2-bedroom apartment in Snohomish County:

- architecture and engineering;
- computer and mathematical jobs;
- health diagnosing and treating practitioners;
- management occupations;
- life, physical and social science occupations.<sup>10</sup>

We know that the cost of single-family homes varies significantly across the County:

- Mukilteo, Edmonds, and Mill Creek consistently had the highest single-family home sale prices in the County over the last 20 years, in 2019 ranging from \$791,250 in Mukilteo to \$653,677 in Mill Creek.
- At the other end of the spectrum, Granite Falls, Arlington, Stanwood, and Marysville have had the least expensive housing in recent years of all cities in the County. In Granite Falls, single-family home sale price averaged \$308,663 in 2019.<sup>11</sup>

While there may be greater affordability in some areas, there are typically longer commutes attendant with those more affordable homes. In addition, as noted above, few households can afford the average price of a single-family home today in Snohomish County.

<sup>8</sup> U.S. Census Bureau. American Community Survey, Table S2506, 2013-2017 5-Year Estimates.

<sup>9</sup> November 2019 data. <https://reports.nlihc.org/oor/washington>

<sup>10</sup> U.S. Census Bureau. American Community Survey, Table S2412, 2013-2017 5-Year Estimates

<sup>11</sup> Snohomish County Assessor's Office.



What we are consistently seeing is that the private housing market does not create housing units affordable to those making less than 60% of AMI without direct government support, and that government incentives are needed in our housing market at higher income levels, up to 80% of AMI. The costs of construction materials, labor, land acquisition, and permitting are simply too high to pencil out at lower per unit prices that will be affordable to these households. As noted above, households at 60% of AMI or below comprise *one third of all households* in the County. While we are concerned about ensuring housing is affordable to *all residents*, those at the lower income levels are particularly dependent on local, state, and federal government action to directly fund or otherwise provide incentives in support of private developers and nonprofit housing agencies.

The chart shown in **Figure 1** below displays current data on housing demand by level of income. In addition to showing the dramatically greater need for housing at lower price points, this chart tells us that **for no household to spend more than 30% of their income towards housing, Snohomish County would need 127,215 additional housing units by 2040—more than 6,300 new units each year.**

In comparison, in the last *three years*, 7,938 housing units have come online in Snohomish County, at a rate of about 2,650 per year. Housing would need to be built at slightly more than double the current rate to meet the projected housing affordability needs. These new housing units also need to be affordable to households across the income spectrum. The vast majority of cost-burdened households today have incomes of 80% of AMI and below. We note that the projected need of 127,215 additional housing units is based on a rough straight-line calculation on current conditions, and we hope that with additional effort both our data inputs, and the results, can improve.



**Figure 1: Snohomish County Cost-burdened Household Projections\***



## Low-Income Housing is Being Lost to Redevelopment and Resale

Another important part of the housing supply challenge is the significant, ongoing loss of existing low-income housing due to redevelopment or resale, typically of multi-family complexes. With housing demand as strong as it is, multi-family housing owners find it profitable to sell to investors, who logically look to maximize their profit by increasing rents or tearing down existing housing and rebuilding. The Joint Center for Housing Studies at Harvard University published a national study looking at a variety of housing trends. It found that there has been a **50-67% decline in low rent housing in Snohomish County between 2011 and 2017**.<sup>1</sup> Community partners presented several troubling examples of these situations in Snohomish County to HART.

Maintaining existing housing is significantly cheaper than building new housing. In terms of least cost options to promote housing affordability, preservation of low-income housing should be a major focus for action.

## Housing Demand Driven Primarily by Population Growth

There are several factors impacting housing demand, including population growth, household size, incomes, credit, transportation access, and populations with special needs.<sup>12</sup> The most significant of these factors is population growth. Snohomish County has seen a dramatic increase in population in recent years and this promises to accelerate over the next twenty years. In addition to new residents moving here from outside Washington, we are seeing population growth from those pushed out of King County and elsewhere in Puget Sound looking for housing that is more affordable.

Between 2010 and 2019, the County experienced a 14.77% increase in population.<sup>13</sup> Between 2020 and 2040, the population is expected to grow an additional 26%, from an estimated 818,700 in 2019 to a forecast population of 1,058,113 in 2040.<sup>14</sup>



\*Figure 1: Snohomish County Cost-burdened Household Projections. U.S. Housing and Urban Development Comprehensive Housing Affordability Strategy Data, 2012-2016 estimates; OFM Growth Management Act population projections for counties, medium series. Image from Freepik.

<sup>12</sup> Housing Background Paper, p. 4, Puget Sound Regional Council (PSRC), June 2018. This background paper provides considerable detail on the components of housing demand and supply in the Puget Sound region.

<sup>13</sup> Washington State Office of Financial Management (OFM). 2019 Population Trends. Retrieved from [https://www.ofm.wa.gov/sites/default/files/public/dataresearch/pop/april1/ofm\\_april1\\_poptrends.pdf](https://www.ofm.wa.gov/sites/default/files/public/dataresearch/pop/april1/ofm_april1_poptrends.pdf)

<sup>14</sup> Ibid.

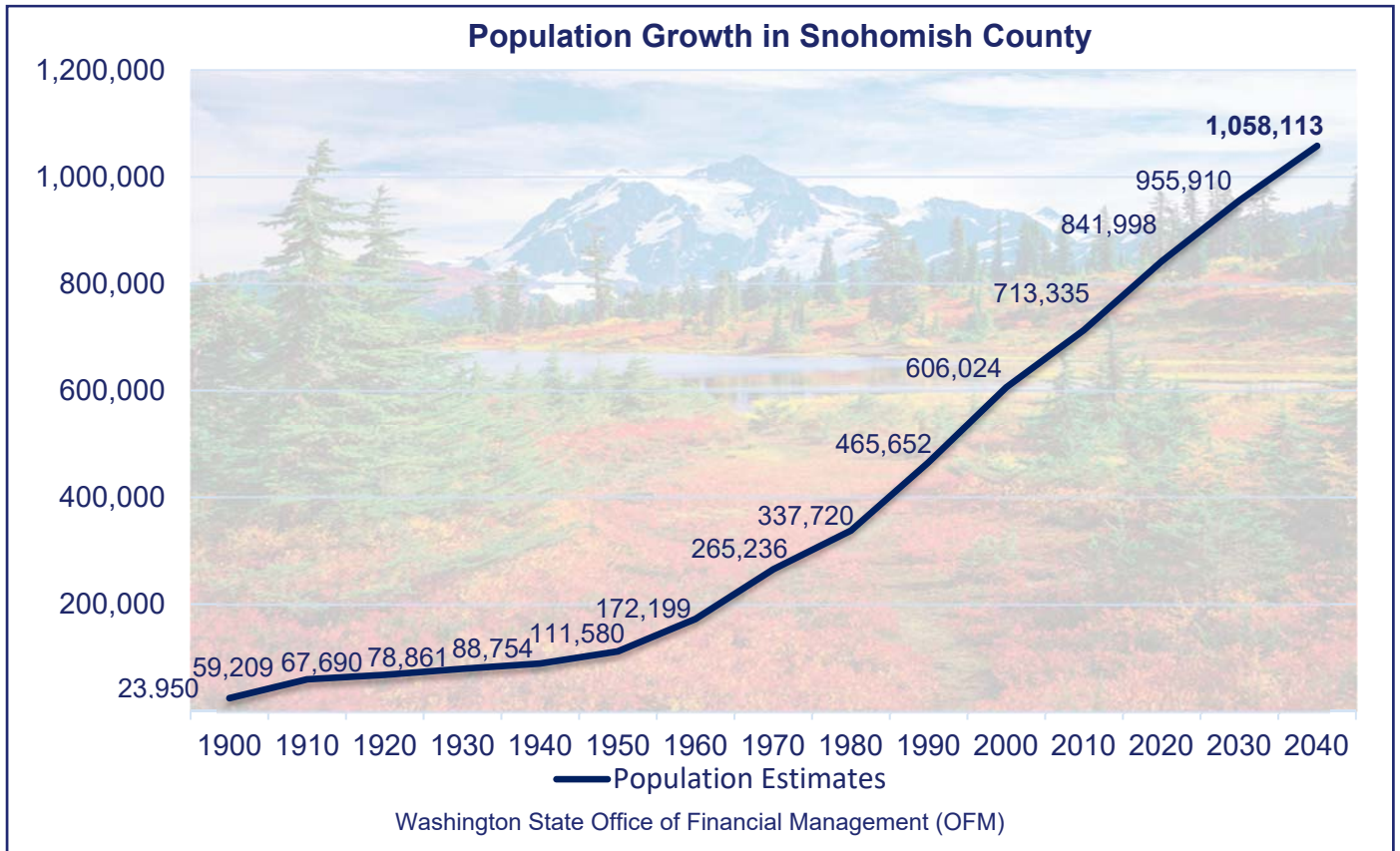

Household size also impacts the number of housing units needed to serve the population. Nearly a quarter of the County population current lives alone, slightly less than the national or statewide average.<sup>15</sup>

**1 in 4**



<sup>15</sup> U.S. Census Bureau, American Community Survey, Table S1101, 2013-2017 5-Year Estimates.



Of course, not all households have the same purchasing power when it comes to housing or other needs. Household Area Median Income (AMI) in Snohomish County in 2017 was \$78,020.<sup>16</sup> Nearly 20% of Snohomish County households made less than \$35,000 a year. In all, about a third of all households are at 60% of AMI or below. About the same number — 36% — have incomes in excess of \$100,000 a year.

### 2017 Household Income Snohomish County, WA

Household Income	% of Households at this income level
Less than \$10,000	4.30%
\$10,000 to \$14,999	2.70%
\$15,000 to \$24,999	6.20%
\$25,000 to \$34,999	6.50%
\$35,000 to \$49,999	10.60%
\$50,000 to \$74,999	17.90%
\$75,000 to \$99,999	15.60%
\$100,000 to \$149,999	20.10%
\$150,000 to \$199,999	9.00%
\$200,000 or more	7.30%

Census Bureau Table S1901, 2013-2017  
ACS 5-Year Estimates

To meet our goal of ensuring housing affordability for *all residents* we need to promote housing construction at *all price points*. But as noted, the private housing market, is simply not able without interventions from government or other actors, to produce units affordable to those at 60% of AMI or below.

**This means that *about one-third of Snohomish County households are in need of housing that will not be produced without governmental or nonprofit interventions of some sort.***

## Housing Supply is Not Keeping Pace with Population Growth

Factors impacting the number of housing units coming on or offline each year include the availability of land, zoning, the cost of construction, and capacity of the housing construction sector.<sup>17</sup>

The rate at which housing units are being constructed in Snohomish County is not keeping pace with our growth in population. In the last two years (2016-2018), the number of units added was 61% less than the growth of households in Snohomish County.<sup>18</sup> The supply gap looks less extreme over the longer term, but still is significant: in the 2010-2018 period overall, the number of housing units added was 7% less than the number of added households. During the prior decade, between 2001 and 2009, 4% fewer housing units were added as compared to the growth in the number of households.<sup>19</sup>

<sup>16</sup> U.S. Census Bureau, American Community Survey, Table S1901, 2013-2017 5-Year Estimates.

<sup>17</sup> Puget Sound Regional Council. (June 2018). Vision 2050. Retrieved from

[https://www.psrc.org/sites/default/files/vision\\_2050\\_housing\\_background\\_paper.pdf](https://www.psrc.org/sites/default/files/vision_2050_housing_background_paper.pdf)

<sup>18</sup> Office of Financial Management.

<sup>19</sup> Ibid.



Statewide, housing construction began to decline precipitously at the onset of the recession in 2007 and did not pick up again until 2013.<sup>20</sup> We have still not built our way out of that shortfall, which has contributed to the number of cost-burdened households.<sup>21</sup>

We have experienced a shortage of housing for sale for nearly a decade in Snohomish County. A representative from the Master Builders Association of King and Snohomish County (MBAKS) met with us, and shared that MBAKS considers a healthy real estate market—in terms of balancing supply and demand—to have about four to six months of inventory for sale at any point in time. Multiple Listing Service (MLS) data for Snohomish County from 2012-2017 indicates a steady downward trend here: there was slightly less than four months availability in 2012 and 0.6 months availability in 2017. This number has improved somewhat since 2017—in September 2019, MLS reported 1.72 months of inventory in Snohomish County<sup>22</sup>—but still falls short of the MBA’s definition of “healthy.” Some real estate professionals fear that this chronic shortage of housing may be our “new normal.”<sup>23</sup>

## The “Missing Middle”

Our existing housing supply is skewed toward single-family homes which are affordable to fewer households than other types of housing. The 2017 U.S. census reported Snohomish County’s inventory of housing that year was composed of 65% single-family detached homes, 30% multi-family, 5% manufactured homes. We do not have countywide statistics to tell us the types of new housing being built across all jurisdictions combined (or the price point of that housing), but in unincorporated Snohomish County in 2017, 70.5% of all housing permits issued were for single-family homes.<sup>24</sup>

We are not seeing sufficient growth of “missing middle” housing. “Middle” housing includes housing of various types other than single-family homes: duplexes, townhomes, and smaller scale multifamily. With appropriate zoning in place, and in some cases additional incentives, the private sector housing market will produce this type of housing. This housing tends to be more affordable than single-family homes.

---

<sup>20</sup> OFM; Puget Sound Regional Council. (June 2018). Vision 2050: Housing Background Paper. Retrieved from [https://www.psrc.org/sites/default/files/vision\\_2050\\_housing\\_background\\_paper.pdf](https://www.psrc.org/sites/default/files/vision_2050_housing_background_paper.pdf)

<sup>21</sup> Cost-burdened households are those that spend 30% or more of their income on housing (including utilities). There are cost-burdened households at all income levels.

<sup>22</sup> Northwest Multiple Listing Service. (2019). Snohomish County. Retrieved from <https://www.nwmls.com/library/CorporateContent/statistics/SCBreakouts.pdf>

<sup>23</sup> Seattle Post Intelligencer. Zosha Millman. (November 2019). Northwest Real Estate Experts: Inventory Shortages the ‘New Normal.’ Retrieved from <https://www.seattlepi.com/realestate/article/Northwest-real-estate-Inventory-Seattle-home-price-14829873.php>

<sup>24</sup> Washington State Employment Security Department. (May 2019). Snohomish County Profile. Retrieved from <https://esd.wa.gov/labormarketinfo/county-profiles/snohomish>





As noted by the Puget Sound Regional Council:

*“Middle” housing can help promote housing diversity, give people greater housing choices, and produce urban densities that support walkable communities, local retail and commercial services, and efficient public transit. Yet availability of these housing options is often few and far in between in many communities, hence the term “missing middle” housing.<sup>1</sup>*

The average single-family home price in Snohomish County in 2019 was \$544,559. The Washington State Office of Financial Management (OFM) estimates that the 2017 area median income in Snohomish County was \$81,779, somewhat higher than the U.S. Census Bureau estimate of \$78,020.<sup>25</sup> Applying either data point, the vast majority of households in Snohomish County cannot afford a single-family home with an average price of \$544,559. Assuming a 3.64% interest rate for a 30-year fixed loan and a 10 percent down payment, the monthly mortgage payment would be approximately \$3,129—amounting to 46-48 percent of the household median income in Snohomish County, which is well above the cost-burdened threshold. A household would need to earn at least \$125,160 annually to afford this payment without spending more than 30% of their income on housing.<sup>26</sup> Facilitating construction of middle housing is a key way we can advance both affordability and home ownership in Snohomish County.

## Social Equity Implications

Rapidly rising housing costs result in displacement of households with lower incomes to areas farther from job centers which are typically less well served by services and transportation systems. As a result of both historic and current practices, communities of color and historically under-served communities are disproportionately impacted by these trends. While we are seeking to improve affordability for all residents, it is important to be mindful of this aspect of our housing affordability challenge.

\* Image Source: Opticos Design, Inc.

<sup>25</sup> OFM. (2019). Median Household Income Estimated by County. Retrieved from [https://www.ofm.wa.gov/sites/default/files/public/dataresearch/economy/median\\_household\\_income\\_estimates.pdf](https://www.ofm.wa.gov/sites/default/files/public/dataresearch/economy/median_household_income_estimates.pdf); U.S. Census Bureau Table S1901, 2013-2017 ACS 5-Year Estimates.

<sup>26</sup> Zillow Mortgage Calculator. Retrieved from <https://www.zillow.com/mortgage-calculator/> and <https://www.zillow.com/mortgage-rates/wa/#/location>. Mortgage estimate includes principal, interest, taxes, and insurance.

# WHERE DO WE GO FROM HERE?



## Local Government's Role on Addressing Housing Affordability

Where do we, as local government officials, best direct our energies in response to the housing affordability challenge? Cities and counties are not permitted by state law to own or operate housing; we rely on partners in the private, nonprofit, and public sectors to create new housing and to operate housing for households with very low-incomes and/or those with special needs. That said, local government is a critical part of the housing affordability equation. Cities and counties have broad authority to implement an array of actions that can positively or negatively impact housing affordability. Our capabilities track directly to the three core challenges we have identified, and around which HART has focused its work:

- Policy and Regulatory Actions

Cities and the county can promote the creation of more housing units through regulatory policy, primarily changes in zoning. We can adjust regulatory policy and rules to reduce the cost of new housing construction by revising permit requirements and fees. We can take steps in support of preservation of existing low-income housing by identifying housing at risk of redevelopment and working with public or nonprofit partners to purchase the housing and thereby decouple it from market pressures.

- Funding

We can provide direct funding support to nonprofit housing providers, for capital or operating costs. We can advocate for more support for these providers from the federal and state government.

- Community Outreach and Engagement

We can engage with residents and community members around the options for how growth is accommodated in our communities. We can also seek to engage more private sector partners in this housing challenge.

Importantly under state law, local government can deploy a broader array of strategies in support of the low-income housing, both in terms of providing direct funding and targeted policy/regulatory actions, than it can for market rate housing.



## Framework Goals for the Action Plan

What we *choose to do* in support of housing affordability should be based on the goals we are trying to achieve and an understanding of the housing market. As noted, our mission is to identify actions that can help us accelerate our ability to meet the housing affordability needs of *all county residents* and set a foundation for continued success through 2050. Building from the three core challenges, HART has identified five framework goals in support of this mission.

Our first three framework goals are ***goals to increase housing affordability at all income levels:***

### GOAL 1

Promote greater housing growth and diversity of housing types and improve job/housing connections

Because of our broader authority to intervene in housing affordable to households with lower incomes, we divide this goal into two sub-goals:

#### SUB-GOAL A

Promotion of greater housing growth and diversity of housing types and job/housing connections at all income levels

#### SUB-GOAL B

Promotion of greater housing growth and diversity of housing types and job/housing connections affordable to households at or below 60% of Area Median Income



## GOAL 2

**Identify and preserve existing low-income housing at risk of rapid rent escalation or redevelopment, balancing this with the need for more density**

There has been a dramatic loss of the most affordable units of housing in Snohomish County in recent years. Preserving remaining housing affordable to households with lower incomes is much less expensive than building new housing. That said, we are mindful that creating large numbers of new housing units will require redevelopment and infill. These competing demands must be balanced.

## GOAL 3

**Increase housing density along transit corridors and/or in job centers, while also working to create additional housing across the entire county**

There are dual benefits from locating housing near transit and job centers in that we both house people and reduce the strain on our congested roads. We realize as well that the need is such that more housing must be built across the county.

Our last two framework goals relate to ***how we want to work together*** to achieve these goals. We have all experienced the challenge of implementing land use changes in our communities. Rezoning for more housing units per acre, or to allow different housing types can be challenging conversations. We can learn from one another about how to engage effectively around these difficult issues, as well as what policy and regulatory changes are more or less productive. Every community is different, but we don't need to re-create the wheel when we are trying to act in alignment: model ordinances and programs can be particularly helpful. In sum, we believe regional collaboration around housing issues will make it easier for each of us to be successful as we tailor programs to meet local conditions and needs.



## GOAL 4

**Develop and implement outreach and education programs for use countywide and by individual cities to raise awareness of housing affordability challenges and support for action**

There is no substitute or shortcut for effective public engagement around difficult issues. There are toolkits that provide samples of best practices in engagement on housing issues that we can each utilize and refine. We believe that effective engagement of residents and partners is necessary to help find the best path ahead for each city and community around the issue of housing affordability.

## GOAL 5

**Track our progress and support ongoing regional collaborations**

Improving housing affordability is an evolving challenge that will continue for the foreseeable future. The more we can engage on this challenge together, learn from each other, partner together, and leverage our successes, the easier will be our journey. We need to track what we are doing and what effect it is having. Are we making progress or losing ground? Existing data sets can be improved. For example, we currently have no easy way to track differing rents by each city. We should take the opportunity to learn from each other and build from that knowledge to be more successful.

HART's Five-Year Housing Affordability Action Plan, presented in the next section of this report, is built around these five framework goals. In addition to eight "Early Action" items we will pursue in 2020, HART has identified 37 action items (two items appear twice, in support of different goals, for a total of 35 different items).

# THE PURPOSE OF THE FIVE-YEAR ACTION PLAN



We strongly encourage cities and the County to consider implementing the strategies in the Action Plan presented below. The strategies are not the only ideas that could be pursued, but after much deliberation, these are the strategies we collectively now endorse. The majority of these strategies are policy and regulatory actions that cities and the County could implement which would reduce the cost of housing construction. Some strategies involve changes to zoning codes that can increase the number of units that can be produced. Other strategies would reduce the tax or fee burden on construction, primarily for low-income housing.

A handful of strategies identify new local funds that could be applied to support low-income housing construction and operation. We acknowledge that the lack of funding supports for low-income housing remains a substantial barrier to progress on our mission and we have not been able to reach consensus on specific funding tools adequate to this task. We are recommending continued effort here through two strategies: the first calls for identifying and promoting additional sources of funding generally; the second involves advocacy for additional funding from the state and federal governments.

How much housing will our Action Plan create? Frankly, we do not know. We are dependent on housing partners—public, nonprofit, and private—to actually build housing. We have not gone through a detailed exercise to estimate the number of housing units that may be created if all our recommendations are adopted by all jurisdictions. We know we are unlikely to see the progress we would like in the area of low-income housing without significant additional funding being identified. That said, we believe the strategies identified in the Action Plan, if broadly implemented, can facilitate creation of significant additional housing affordable to households across the income spectrum.

Publication of the Action Plan is a first step and much work remains ahead of us. HART will continue work on framework Goals 4 and 5 in 2020 through several Early Action items. We expect that because of that work, we will identify additional strategies in support of those two goals. We want to check-in periodically to see what is being accomplished by cities and the County, and consider adjustments to the Action Plan. We will continue to seek input from partners as to what is most effective, and to learn as we go. We hope the Five-Year Action Plan will be a living document that will evolve over time based on our collective experience.

# HART'S FIVE-YEAR HOUSING AFFORDABILITY ACTION PLAN



HART's recommendations to all Snohomish County cities and Snohomish County government for responding to our housing affordability challenges are presented below. The Action Plan is based on **five framework goals**; three that focus on increasing housing affordability and two that focus on how we propose to work together.





“**Early Action**” items that HART members will begin working on in early 2020 are presented first. These are followed by the **Framework Goals** with supporting **strategies** for each framework goal. The strategies are divided into two types: **policy and regulatory strategies** and **funding strategies**.

The Action Plan also identifies several “**Joint Action**” items, which are items we recommend be pursued either through a single countywide unified strategy/action, or by alignment of actions across individual jurisdictions. “Joint Action” items are indicated as follows:



indicates actions that we recommend be pursued in a **unified**, countywide approach.



indicates actions we see as best pursued by individual jurisdictions but with **alignment** in our approach.

## Early Action Items

### 1. Encourage cities to enter into cooperation agreements with the Housing Authority of Snohomish County (HASCO) and Everett Housing Authority.

- *Only two cities currently have such agreements: Lynnwood and Snohomish. Snohomish County government and Everett also have equivalent terms in place. Cooperation agreements simply authorize a Housing Authority to operate within a jurisdiction. The agreements require no financial commitments by a city and do not impact local zoning authority. These agreements can facilitate quicker action to preserve affordable multifamily developments put up for sale, or to acquire real property suitable for low-income housing.*
- **2020 Leadership:**                     .

### 2. Implement the state sales tax shift to local governments for up to 20 years to fund low-income housing as authorized by HB 1406, as authorized by Legislature in 2019.

- *Nearly all cities as well as the County have taken initial steps to secure the state sales tax monies moving forward into 2020 and beyond. The goal in 2020 is to share information on how jurisdictions plan to apply these funds.*
- **2020 Leadership:**                     .





**3. Lobby for changes in state and federal law that will enable more consolidated and streamlined funding to support low-income housing.**

- *The magnitude of our low-income housing needs will require additional funding from state and federal government. Working together, we can more effectively advocate for these funds.*
- **2020 Leadership:** \_\_\_\_\_.

**4. Review and consider recommendations from existing toolkits to engage communities around the issue of housing affordability.**

- *Effective education and outreach is critical to build understanding and support for the strategies we identify in this plan to increase housing affordability. Toolkits for this purpose from the Association of Washington Cities and the British Columbia Housing Authority have been shared with us. We are asking that these toolkits be reviewed and discussed by all cities and the County. We hope these toolkits can be adapted for local and regional use and provide guidance on constructive community engagement around our housing affordability challenges.*
- **2020 Leadership:** \_\_\_\_\_.

**5. Foster community conversations about density.**

- *We encourage all cities and the County to initiate discussions with residents about the housing affordability challenge. Increasing density is a foundational tool to increase housing affordability, and community engagement around options here is an essential starting point.*
- **2020 Leadership:** \_\_\_\_\_.

**6. Engage private sector partners – large employers, others – in helping to finding solutions to our housing affordability challenge.**

- *Employers have a stake in housing affordability. We believe the private sector can be important partners in efforts to improve housing affordability. We plan to reach out to large employers in the County in 2020 to see how they may be willing to work with us to address this challenge.*
- **2020 Leadership:** \_\_\_\_\_.



**7. Confirm and support an ongoing structure for regional collaboration around production of housing affordable across the income spectrum.**

- *While HART is committed to meeting in 2020 in furtherance of our Five-Year Action Plan, it may be that another group is best positioned to support this work in the future. We will make a recommendation on this in 2020.*
- **2020 Leadership:** HART.

**8. Tracking progress on the Plan.**

- *We want to share information about what cities and the County are doing in furtherance of the Action Plan and improve our data collection to measure our progress. We anticipate creation of an inter-jurisdictional staff workgroup to propose targeted and improved means of data collection.*
- **2020 Leadership:** HART.



## Five-Year Action Items

Beyond the eight Early Action Items, HART has identified 37 strategies (two appear twice, in support of different goals). Strategies are not presented in prioritized order. Please see Supplemental Report [\[weblink\]](#) for additional information regarding each strategy.

**GOAL 1:** Promote greater housing growth and diversity of housing types at all levels of affordability and improve job/housing connections

**SUB-GOAL A:** Promote greater housing growth and diversity of housing types and job/housing connections at all levels of affordability

## Policy and Regulatory Strategies:

### 1.A.1 Establish specific housing affordability goals in city and county comprehensive plans and provide more accurate information into the development of those plans.



- *The County and cities will be working on updates to existing comprehensive plans to be completed by 2023, as required by state law. We hope the work of HART will inform those updates.*

### 1.A.2 Ensure adequate Buildable Land Supply for housing.



- *The state Growth Management Act requires the County and cities periodically assess the adequacy of buildable land supply based on population and zoning. Our work confirms the importance of this effort.*

### 1.A.3 Increase SEPA<sup>33</sup> categorical exemption thresholds for housing developments.



- *This action item can reduce the process time and cost for housing developers. Many protections offered through SEPA processes are assured through other existing regulations, and the vast majority of SEPA reviews are findings of non-significance. The SEPA process can add months of time and risk to housing development projects. Some types of exemptions may require additional state legislation, but cities and counties are encouraged to review what can be accomplished within existing laws and move together in alignment here for maximum impact.*

<sup>33</sup> State Environmental Policy Act CH. 43.21C RCW.



**1.A.4 Facilitate more efficient deal assembly and development timelines / promote cost-effectiveness through consolidation, coordination, and simplification.**

- ➡ • *A wide array of tactics could be deployed to make the permitting process quicker and easier for housing developers. The more these processes and requirements are in alignment across jurisdictional boundaries, the easier it is for developers to work in multiple jurisdictions. Local governments are encouraged to look for these opportunities within their existing land use and permitting codes, and work in alignment with one another on these types of code changes.*

**1.A.5 Remove barriers by reducing construction costs and delays and expedite the permit process.**

- ➡ • *As the local land-use authority, cities and the County have considerable control over development permitting processes. Delays in permit processes cost developers money. We see opportunities here for alignment across jurisdictional boundaries.*

**1.A.6 Increase housing variety allowed at a range of affordability levels both in single-family zones, in areas with connections to jobs, and along transit corridors, including consideration of zoning for duplex, triplex, 4-plex, courtyard apartments, etc.**

- *When local zoning allows a greater variety of housing types, it makes it possible to create more units per acre — facilitating increased supply of housing — as well as reduce per unit costs. Particular importance should be given to increasing zoned residential capacity near jobs and/or transit corridors to reduce pressure on the transportation system as our population grows.*

## **Funding Strategies:**

**1.A.7 Apply for state planning grants to develop housing elements of local comprehensive plans in connection with increasing density as authorized by HB1923 and adopted by the State Legislature in 2019. Apply alone or with other cities.**

- ➡ • *The State Legislature in 2019 authorized new funds for planning grants which may be very helpful as jurisdictions look to update local plans in response to housing affordability challenges.*



### 1.A.8 Implement Multi-Family Property Tax Exemption programs at local and county level.<sup>34</sup>

- *The Multi-Family Property Tax Exemption (MFTE) program has been in place in Washington for decades and is available to all cities. Most cities in the County have implemented an MFTE program of some sort. Generally, MFTE provides a time-limited exemption from local property tax for developers as an incentive to build multi-family housing; depending on the time period involved, the deferral can be targeted to housing affordable to lower income multi-family housing, or to all multi-family housing. Jurisdictions are encouraged to review their programs to see if they can be revised or expanded to strengthen the incentives for multi-family housing development.*

### 1.A.9 Encourage banking and insurance industry support for condominium projects as homeownership solution.

- *Multi-family home ownership is generally less expensive than single-family home ownership. With recent changes in state law, condominium construction becomes less problematic, assuming financing can be secured: knowing there is public support for this type of development may make financing support more likely. Local zoning to allow condominium developments is also needed.*

**SUB-GOAL B:** Promote greater housing growth and diversity of housing types and job/housing connections for homes affordable to households at or below 60% AMI

## Policy and Regulatory Strategies:

### 1.B.1 Prioritize *affordability* and *accessibility* within a half mile walkshed of existing and planned frequent transit service, with particular priority near high-capacity transit stations. Require some amount of low-income housing in development near transit hubs.

- *Low-income housing must be paired with affordable, accessible, safe, and equitable transportation. Households with lower incomes may not have ready access to private transportation, so housing that is walkable to transit options or within the ADA three-quarter mile boundary is particularly important. Cities on transit corridors could increase impact by working together on these ideas; however, every city and the County can consider ways to implement this strategy. Transit agencies are key partners.*

<sup>34</sup> This strategy can be targeted to support housing at all income levels, or just lower income housing; see funding strategy 1.B.9.



### **1.B.2 Revise local zoning to encourage Accessory Dwelling Units (ADU).**

- *ADUs are a low-cost housing option, wherein an additional housing unit is built on an existing single-family lot, for example, over a free-standing garage, or in a separate structure behind the existing home. Many cities currently allow ADUs. They are most viable in urban areas with sewer systems in place. This strategy involves revising zoning to allow one or two ADUs on single-family lots. Reducing requirements associated with residency, lot size, parking, setbacks and architectural requirements may significantly increase the likelihood of ADUs being built.*

### **1.B.3 Encourage cities and the County to proactively develop programs for facilitating the granting of density bonuses for development on church-owned properties (implementing HB 1377, as authorized by Legislature in 2019).**

- *State legislation passed in 2019 requires cities to offer density bonuses to churches and other religious organizations seeking to develop their property for low-income housing. This strategy proposes cities facilitate these types of projects by being prepared in advance, so that projects may move ahead more quickly.*

### **1.B.4 Reduce short plat threshold for low-income housing projects.**

- *This can have a high impact on facilitating development of low-income housing by reducing land costs. The typical rule allowing short plats for up to 4 lots can be changed through a local administrative process to allow short plats for up to 9 lots. An even broader approach would be to change the threshold for all housing projects, not just low-income housing.*

### **1.B.5 Implement inclusionary zoning incentives to encourage developers to produce low-income housing.**

- *Zoning incentives for low-income housing can take a number of forms, all essentially intended to reduce the cost of construction by allowing more housing units on a parcel of land than would otherwise be permitted. Allowing greater building heights, smaller setbacks, greater floor area ratio, or less open space or parking (see below) in exchange for including low-income housing units in a multi-family development are all potential components of this strategy.*



### 1.B.6 Reduce parking requirements for low-income housing developments.

- *The cost of building structured parking or reserving a substantial portion of a project site for parking can significantly increase the per-unit cost and/or reduce the number of units that can be built. Recent state legislation (E2SHB 1923) requires a reduction of parking requirements for projects serving households at 50% or less of Area Median Income within 0.25 miles of frequent transit service. Cities and the County are encouraged to consider broader reductions of parking requirements in connection with low-income housing developments.*

## Funding Strategies:

### 1.B.7 Study funding mechanisms and pursue joint advocacy efforts.



- *Creation of housing affordable to those at or below 60% of Area Median Income will typically not be provided without governmental intervention and/or subsidy of some type. These projects often involve securing and leveraging multiple funding sources; even a small amount of funding from a local jurisdiction can be leveraged to secure other resources. Without significant new federal, state, regional, and/or local funding contributions, we can expect limited progress in building more low-income housing. HART recognizes that we must continue to consider ways in which we can inject additional funds into the construction and operation of low-income housing.*

### 1.B.8 Provide surplus and under-utilized publicly owned property for low-income housing.

- *Finding and purchasing land is a major challenge in the construction of all housing. It is typically 10 to 20 percent of the cost of a project. Donating real property, or offering discounted long term leases for developers of low-income housing, can be a particularly effective way to make such projects viable. Jurisdictions are encouraged to survey their existing real estate holdings and determine if any properties may be declared surplus and made available for low-income housing development.*



### 1.B.9 Implement Multi-Family Property Tax Exemption (MFTE) programs at local and county level.

- *This strategy, first discussed above at Strategy 1.A.8, can be applied to any multi-family housing development (up to 8 year exemptions), but under state law longer term exemptions (12 years) can be provided for low-income housing developments. This can be a particularly effective way of reducing costs of construction and operation of such housing. Jurisdictions are encouraged to examine their existing MFTE programs to increase the incentives provided for construction of low-income housing and extend the term of years for which such housing is required to remain affordable.*

### 1.B.10 Waive or reduce fees and charges for low-income housing projects.

- *Local impact fees and charges can add thousands of dollars per unit cost of construction. Waiving or reducing city- or County-imposed fees does reduce local revenue, but can be a significant support in financing more units of low-income housing. Fees to be considered here include any locally-imposed impact fees, mitigation fees, or utility connection charges.*

### 1.B.11 Establish a county growth fund for low-income housing by setting aside a portion of new construction property taxes.



- *This is one of the few “new money” proposals in our Action Plan. The impact would be much greater if all jurisdictions supported a single fund, rather than implement the concept city-by-city. The basic idea is for each jurisdiction to agree to set aside an agreed upon portion of new construction property tax receipts. In 2016, new construction property tax receipts totaled \$15 million in Snohomish County; a 10% set aside would have created \$1.5 million in funding for low-income housing. An agreed upon process would need to be developed for how such funds were both committed and then allocated.*

### 1.B.12 Expand supports for low-income renters and people with disabilities; fund operating costs for housing service providers.

- *All operators of low-income and special needs housing who spoke to HART identified the need for ongoing operating funds for these projects as a major challenge. Simply being able to construct a project or buy an existing property for low-income or special needs housing is only the first step: supports must be in place to provide ongoing supportive services to residents to ensure long-term stability. A variety of funding sources have been suggested to HART for these purposes, including new state or federal funds, expansion of low-income housing tax credits, or other direct public funding.*





### 1.B.13 Support creation of Community Land Trusts (CLT).

- *CLTs are a means to ensure permanent affordability remains in place on investments in housing included in these trusts. CLTs are typically formed as nonprofit corporations who own land and lease homesites; the homes are more affordable because land purchase is not involved. In exchange, the rate of return that the homeowner can receive on resale is capped to ensure the property remains affordable under successive owners. There is a start-up CLT in Snohomish County and CLTs operate in nearby counties. CLTs can be implemented at a city-by-city level or more broadly, but larger scale efforts will be more sustainable. The key government action is to require permanent affordability in connection with a donation or investment.*

### 1.B.14 Implement policy/zoning changes to increase Snohomish County/city projects' competitiveness for state and federal funding.

- *State and federal grant programs are the major sources of funding for low-income housing. It is important that we be as competitive as possible for these dollars. A number of helpful zoning changes have been identified by partners as actions local government can take and/or specify in applications, including: ensuring that multi-family (MF) zoning is allowed in a jurisdiction, particularly near transit; designating community revitalization areas; allowing early learning facilities in MF zones; and allowing modular housing.*

### 1.B.15 Target federal CDBG (Community Development Block Grant) and HOME (HOME Investment Partnerships Program) funds for low-income housing creation and rental assistance.

- *These federal funds are jointly administered for all cities and the County except Marysville and Everett which have their own funding and policy processes. The allocation of these funds is largely directed by federal formulas. HOME funds are critical to construction of low-income housing units. Generally, new housing construction is not eligible for CDBG funding, with some exceptions. Because allocation formulas are set by federal law, this item is anticipated to have low additional impact.*

### 1.B.16 Advocate for expansion of funding of the state public works trust fund.



- *The state public works trust fund is a revolving loan fund for cities, counties, and special purpose districts. Loans from these funds could be critical in enabling construction of new housing in some of Snohomish County's smaller cities that have sewer and water system moratoriums.*



## GOAL 2: Identify and preserve existing housing at risk of rapid rent escalation or redevelopment, balancing this with the need for more density

### Policy and Regulatory Strategies:

#### 2.1 **Protect communities of color, historically underserved communities, and low-income communities from displacement by gentrification.**

- *As a result of location or real estate market trends, we often see existing housing for underserved communities being prime for redevelopment. Anti-displacement strategies, and increasing household choice for these residents are important strategies. At its core, anti-displacement strategies involve purchasing housing and decoupling it from market pressures. Other funding supports, discussed below at Strategy 2.4 are also important.*

### Funding Strategies:

#### 2.2 **Establish short term acquisition revolving loan fund to enable rapid response to preserve low-income housing developments when they are put on the market.**

- *Both public and private donations could be used to establish such a fund, which could have a high impact in preserving low-income housing at risk of conversion, particularly if potential government or nonprofit owners are unable to fully secure purchase funds quickly. This type of tool could be used to preserve housing affordable at lower income levels, whether multi-family or mobile home developments.*

#### 2.3 **Increase investments in communities of color, historically underserved communities, and low-income communities by developing programs and policies that serve individuals and families at risk of displacement.**

- *This is a companion to Strategy 2.1. To the extent these communities live on lower cost property, they are often at higher risk of redevelopment — and loss of both their community and their affordable homes. There are a number of related strategies here including community land trusts, cooperation agreements with the Housing Authority of Snohomish County, and other funding mechanisms to facilitate purchase of low-income housing at risk of redevelopment.*



**2.4 Provide low-income homeowners with low-interest/deferred payment to repair homes and/or fund home repair programs for households with lower incomes.**

- *HART members find this strategy conceptually promising, but we understand that it can be very difficult to implement such programs; the Housing Authority of Snohomish County (HASCO) recently terminated their home repair loan program due to the administrative challenges and costs as compared to other types of assistance. Due to administrative effort required, this may be better suited to larger scale efforts.*

**Goal 3: Increase housing density along transit corridors and/or in job centers, while acknowledging that additional housing is needed across the entire County**

## **Policy and Regulatory Strategies:**

**3.1 Prioritize affordability and accessibility within half a mile walkshed of existing and planned frequent transit service, placing particular priority on high-capacity transit stations. Require some amount of low-income housing in development near transit hubs.**

- *This item is also presented above as Strategy 1.B.1—promoting construction of housing affordable to households at or below 60% of Area Median Income.*

**3.2 Increase variety of housing types allowed at a range of affordability along transit corridors through increasing zone density and providing incentives to include low-income units.**

- *This strategy is similar to Strategies 1.B.1 and 3.1—but with the focus on all income levels. The more housing we can develop near major transit access, the more potential relief we provide to our transportation system. Perhaps one positive aspect of being one of the last areas to see the light rail investment from Sound Transit is that we can act now to acquire property along these future corridors before it hits peak pricing. We have time to coordinate across jurisdictions and thoughtfully ensure more zoned capacity is available where it will be most helpful.*

**3.3 Reduce parking requirements for multi-family projects located near transit.**

- *As noted above, reducing parking requirements can significantly reduce the cost per unit of housing. There is particular logic for considering this change in zoning where residents are more able to use mass transit to meet their needs.*



**3.4 Increase Snohomish County/City projects' competitiveness for state and federal funding by ensuring multi-family zoning near transit.**

- *This strategy is related to Strategy 1.B.14 above. Jurisdictions which have multi-family zoning near transit will be more competitive for federal and state low-income housing funding support.*

## Funding Strategies:

**3.5 Maximize resources available for Transit Oriented Development (TOD) in the near term.**

- *“Resources” in this context can mean staffing, legislation, policy, or funding. Aligning all types of resources to promote development around transit can reduce the need for single occupancy vehicles. Coordinating locally with Sound Transit and housing developers on this strategy is key to facilitate construction of affordable TOD.*

**Goal 4:** Implement outreach and education programs, countywide and within individual jurisdictions, to raise awareness of housing affordability challenges and support for action

## Policy and Regulatory Strategies:

**4.1 Engage communities of color, historically underserved communities, and low-income communities in affordable housing development and policy decision.**

- *These communities are often most in need of low-income housing and most vulnerable to having their existing housing redeveloped or subject to significant rent increases. Cities and housing agencies should use a race and social equity lens and/or racial equity toolkit when making policy decisions regarding low-income housing. Community-based policy development is consistent with the overall philosophy that as elected officials we are here to understand and promote the needs of our residents.*



#### 4.2 Expand engagement of non-governmental partners to support efforts to build and site more affordable housing.

- *While local government can do a lot to address our housing affordability challenges, we cannot resolve the housing challenge alone. To accomplish our goals here we must both continue and expand our engagement with partners. For example, we have seen large employers in other counties and other states become major funding partners with local government agencies on the issue of affordable housing. Can we do something similar in Snohomish County? This strategy calls for exploring the possibilities.*

### GOAL 5: Track our progress and support ongoing regional collaborations

- *Two of our eight “Early Action” items are built around this goal. HART plans to spend time in 2020 to identify the key data we want to track and to create multi-jurisdictional workgroups to pursue and refine that data. We also plan to identify an ongoing “home” for this Action Plan, as it evolves over time and we continue to track our progress.*



# CONCLUSION



In recent years, we have seen a significant decrease of housing affordability in Snohomish County. Housing production is not keeping pace with the needs of our growing population—either in terms of housing units created or the cost of those units. Fully one-third—33%—of Snohomish County households are “cost-burdened,” spending more than 30% of their income on housing costs including utilities. These households are at all income levels. But the challenge is greater when we look at the needs of our low-income neighbors. Without funding supports from government or nonprofit organizations, or other governmental incentives, the private housing market is generally unable to produce units affordable to those households with incomes of 60% of Area Median Income or below. Currently, approximately one-third of Snohomish County households are in need of housing that cannot be produced without governmental or nonprofit interventions.

As members of HART, we are committed to ensuring progress in improving housing affordability in Snohomish County. Local government is a necessary partner for making significant progress on housing affordability. Because cities and counties are not authorized by law to either own or operate housing, we need to work in partnership with housing developers (both for-profit and nonprofit); local housing authorities; state and federal funders; housing advocates; local special needs and low-income housing operators; and other community advocates to accomplish our housing affordability goals. In addition, we believe we can benefit from bringing new partners to this cause from the private sector.

Over the course of this effort, we heard from many partners in the housing industry. They helped us to understand and prioritize among the many actions we can take to support this work. Some of these requests are relatively simple to address; others are very difficult. Our Five-Year Housing Affordability Action Plan identifies 5 framework goals, 8 Early Action items that are to be pursued this year, and 37 supporting strategies to be completed in future years. We acknowledge that the Action Plan is simply the first step. Much work lies ahead, and we want our Action Plan to evolve over time as we learn from future experience and consider new approaches and solutions.

The challenge of housing affordability is not about “other people.” It is a problem facing our own families and friends; our grown children trying to make it on their own; our neighbors; people we interact with every day as we shop, pick up our kids from school, take an aging parent to the doctor, or join in community events. The good news is there is ample evidence—real examples throughout Snohomish County, the Puget Sound, and nationally—that we can maintain and evolve vibrant, welcoming, livable, safe communities at the same time as we work to meet the housing affordability needs of all our residents.

With the support of our fellow city and county government officials in Snohomish County, we can make progress on housing affordability. The problem is urgent, and becoming more critical each year. We hope each City Council and the County Council will consider the items in our Action Plan and take steps in 2020 and each year thereafter to address this challenge and ensure better future for our communities.



# APPENDIX

## Attachment A:

### Summary of the Snohomish County Housing Affordability Taskforce (HART) Five-Year Housing Affordability Action Plan

HART's recommendations to all Snohomish County cities and Snohomish County government for responding to our housing affordability challenges are presented below. The Action Plan is based on **five framework goals**; three that focus on increasing housing affordability, and two goals that focus on how we propose to work together.





**“Early Action”** – Items that HART and its members will begin working on in early 2020 are presented first, followed by the **Framework Goals** with supporting **strategies** for each Goal. The strategies are divided into two types: **policy and regulatory strategies** and **funding strategies**.

**“Joint Action”** – Items we recommend involve a countywide unified strategy/action, or alignment of individual jurisdiction action—are indicated as follows:



indicates actions that we recommend be pursued in a **unified**, countywide approach.



indicates actions we see as best pursued by individual jurisdictions but with **alignment** in our approach.

## Early Action Items

**Early Action Items** are strategies that HART and its members will begin working on in early 2020.

1. **Encouraging cities to enter into cooperation agreements with the Housing Authority of Snohomish County (HASCO) and Everett Housing Authority.**
2. **Implementing the state sales tax shift to local governments for up to 20 years to fund low-income housing authorized by HB 1406, as authorized by Legislature in 2019.**
3. **Lobbying for changes in state and federal law that will enable more consolidated and streamlined funding to support low-income housing.**
4. **Reviewing and consider recommendations from existing toolkits to engage communities around the issue of housing affordability.**
5. **Fostering community conversations about density.**
6. **Engaging private sector stakeholders – large employers, others – in helping to finding solutions to our housing affordability challenge.**
7. **Confirming and support an ongoing structure for regional collaboration around production of housing affordable across the income spectrum.**
8. **Tracking progress on the Action Plan.**









## Five-Year Action Items

NOTE: Strategies are not presented in prioritized order. Please see Supplemental Report [weblink] for additional information regarding each strategy.

**GOAL 1:** Promote greater housing growth and diversity of housing types at all levels of affordability and improve job/housing connections

**SUB-GOAL A:** Promote greater housing growth and diversity of housing types and job/housing connections at all levels of affordability

### Policy and Regulatory Strategies:

- 1.A.1  Establish specific housing affordability goals in city and county comprehensive plans and provide more accurate information into the development of those plans.
- 1.A.2  Ensure adequate Buildable Land Supply for housing.
- 1.A.3  Increase SEPA<sup>35</sup> categorical exemption thresholds for housing developments.
- 1.A.4  Facilitate more efficient deal assembly and development timelines / promote cost-effectiveness through consolidation, coordination, and simplification.
- 1.A.5  Remove barriers by reducing construction costs and delays and expedite the permit process.
- 1.A.6 Increase housing variety allowed at a range of affordability levels both in single-family zones, in areas with connections to jobs, and along transit corridors, including consideration of zoning for duplex, triplex, 4-plex, courtyard apartments, etc.

### Funding Strategies:

- 1.A.7  Apply for state planning grants to develop housing elements of local comprehensive plans in connection with increasing density as authorized by HB1923 and adopted by Legislature in 2019. Apply alone or with other cities.
- 1.A.8 Implement Multi-Family Property Tax Exemption (MFTE) programs at local and county level.<sup>36</sup>
- 1.A.9 Encourage banking and insurance industry support for condominium projects as homeownership solution.

<sup>35</sup> State Environmental Policy Act CH. 43.21C RCW.

<sup>36</sup> This strategy can be targeted to support housing at all income levels, or just lower income housing; see funding strategy 1.B.9.





**SUB-GOAL B:** Promote greater housing growth and diversity of housing types and job/housing connections for homes affordable to households at or below 60% AMI

## Policy and Regulatory Strategies:

- 1.B.1 **Prioritize *affordability* and accessibility within a half mile walkshed of existing and planned frequent transit service, with particular priority near high-capacity transit stations. Require some amount of low-income housing in development near transit hubs.**
- 1.B.2 **Revise local zoning to encourage Accessory Dwelling Units (ADU).**
- 1.B.3 **Encourage cities and the County to proactively develop programs for facilitating the granting of density bonuses for development on church-owned properties (implementing HB 1377, as authorized by Legislature in 2019).**
- 1.B.4 **Reduce short plat threshold for low-income housing projects.**
- 1.B.5 **Implement inclusionary zoning incentives to encourage developers to produce low-income housing.**
- 1.B.6 **Reduce parking requirements for low-income housing developments.**

## Funding Strategies:

- 1.B.7  **Study funding mechanisms and pursue joint advocacy efforts.**
- 1.B.8 **Provide surplus and under-utilized publicly owned property for low-income housing.**
- 1.B.9 **Implement Multi-Family Property Tax Exemption (MFTE) programs at local and county level.**
- 1.B.10 **Waive or reduce fees and charges for low-income housing projects.**
- 1.B.11  **Establish a county growth fund for low-income housing by setting aside a portion of new construction property taxes.**
- 1.B.12 **Expand supports for low-income renters and people with disabilities; fund operating costs for housing service providers.**
- 1.B.13 **Support creation of Community Land Trusts (CLT).**
- 1.B.14 **Implement policy/zoning changes to increase Snohomish County/city projects' competitiveness for state and federal funding.**
- 1.B.15 **Target federal CDBG (Community Development Block Grant) and HOME (HOME Investment Partnerships Program) funds for low-income housing creation and rental assistance.**
- 1.B.16  **Advocate for expansion of funding of the state public works trust fund.**



## GOAL 2: Identify and preserve existing housing at risk of rapid rent escalation or redevelopment, balancing this with the need for more density

### Policy and Regulatory Strategies:

- 2.1 Protect communities of color, historically underserved communities, and low-income communities from displacement by gentrification.

### Funding Strategies:

- 2.2 Establish short term acquisition revolving loan fund to enable rapid response to preserve low-income housing developments when they are put on the market.
- 2.3 Increase investments in communities of color, historically underserved communities, and low-income communities by developing programs and policies that serve individuals and families at risk of displacement.
- 2.4 Provide low-income homeowners with low-interest/deferred payment to repair homes and/or fund home repair programs for households with lower incomes.

## Goal 3: Increase housing density along transit corridors and/or in job centers, while also working to create additional housing across the entire county

### Policy and Regulatory Strategies:

- 3.1 Prioritize affordability and accessibility within half a mile walkshed of existing and planned frequent transit service, placing particular priority on high-capacity transit stations. Require some amount of low-income housing in development near transit hubs.
- 3.2 Increase variety of housing types allowed at a range of affordability along transit corridors through increasing zone density and providing incentives to include low-income units.
- 3.3 Reduce parking requirements for multi-family projects located near transit.
- 3.4 Increase Snohomish County/city projects' competitiveness for state and federal funding by ensuring multi-family zoning near transit.

### Funding Strategies:

- 3.5 Maximize resources available for Transit Oriented Development (TOD) in the near term.



**Goal 4:** Implement outreach and education programs, countywide and within individual jurisdictions, to raise awareness of housing affordability challenges and support for action

### Policy and Regulatory Strategies:

- 4.1 **Engage communities of color, historically underserved communities, and low-income communities in affordable housing development and policy decision.**
- 4.2 **Expand engagement of non-governmental partners to support efforts to build and site more affordable housing.**

### **GOAL 5:** Track our progress and support ongoing regional collaborations

Two of our eight “Early Action” items are built around this goal. HART plans to spend time in 2020 to identify the key data we want to track and to create multi-jurisdictional workgroups to pursue and refine that data. We also plan to identify an ongoing “home” for this Action Plan, as it evolves over time and we continue to track our progress.





## Attachment B<sup>30</sup>:

# Many Types of Households Struggle with Housing Costs

Fair Market Rent for a two-bedroom apartment in Snohomish County was \$1,899 during 2019





## Snohomish County's

### Housing Affordability Regional Task Force's Mission:

Collaboratively develop a five-year action plan that identifies priorities for county and city governments to accelerate collective ability to meet the housing affordability needs of all Snohomish County residents and set a foundation for continued success through 2050.

Goals to increase housing affordability at all income levels

Promote greater housing growth and diversity of housing types at all levels of affordability and improve jobs/housing connection

Identify and preserve existing housing at risk of rapid rent escalation or redevelopment balancing this with the need for more density

Increase housing density on transit corridors and/or in job centers, while also working to create additional housing across the entire county

### Snohomish County Cost-Burdened Household Projections

	0-30% AMI	31-50% AMI	51-80% AMI	81-100% AMI	100% AMI	Total
<b>Current Need</b>	29,425	23,955	17,955	9,465	10,285	91,085
<b>Growth to 2040</b>	11,672	9,502	7,122	3,754	4,080	36,130
<b>Subtotal</b>	<b>41,097</b>	<b>33,457</b>	<b>25,077</b>	<b>13,219</b>	<b>14,365</b>	<b>127,215</b>

### Goals for moving HART forward together

Implement outreach and education programs for use countywide and by individual jurisdictions to raise awareness of housing affordability challenges and support for action

Track progress and support ongoing regional collaborations

<sup>30</sup>Housing Authority of Snohomish County. 2019 Policy Priorities. Retrieved from [https://hasco.org/wp-content/uploads/2019/04/2019-one-pager\\_FINAL.pdf](https://hasco.org/wp-content/uploads/2019/04/2019-one-pager_FINAL.pdf)  
 National Low Income Housing Coalition. Out of Reach 2019. Retrieved from <https://reports.nlihc.org/sites/default/files/or/files/reports/state/WA.pdf>  
 Social Security Administration (2020). Retrieved from <https://www.ssa.gov/news/press/factsheets/colafacts2020.pdf>  
 Washington State Employment Security Department. 2019 Occupational Employment Statistics. Retrieved from <https://esd.wa.gov/labormarketinfo/occupations>  
 Washington State Department of Labor and Industries. 2020 Minimum Wage. Retrieved from <https://lni.wa.gov/workers-rights/wages/minimum-wage/>

# Regional Housing Needs Assessment – Current & Future Housing Needs



**GMPB • November 19, 2020**

# Components of the Strategy

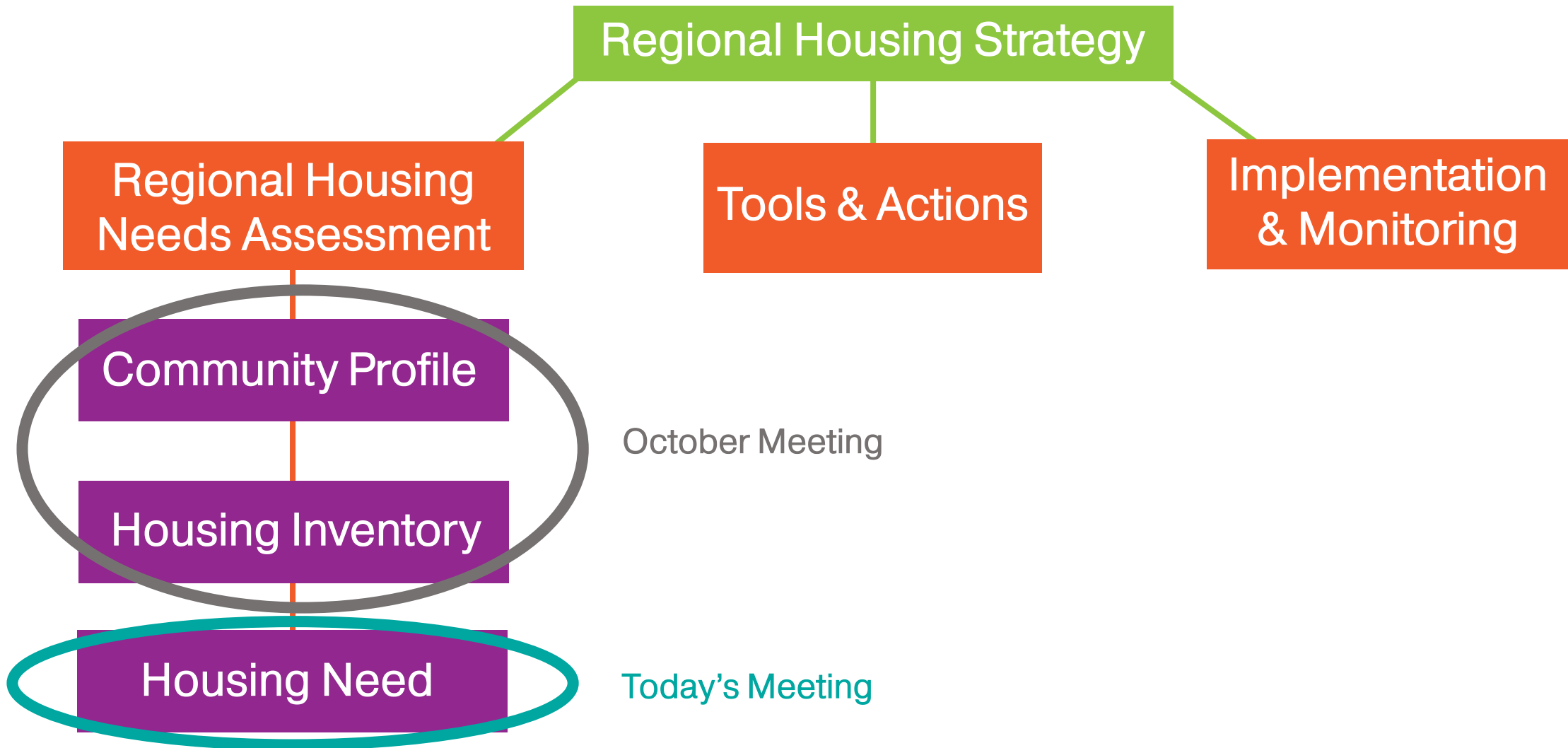



# Recap of Findings Shared at October Meeting



# Rent and home values have risen dramatically over the past decade

## Median Home Value & Rent

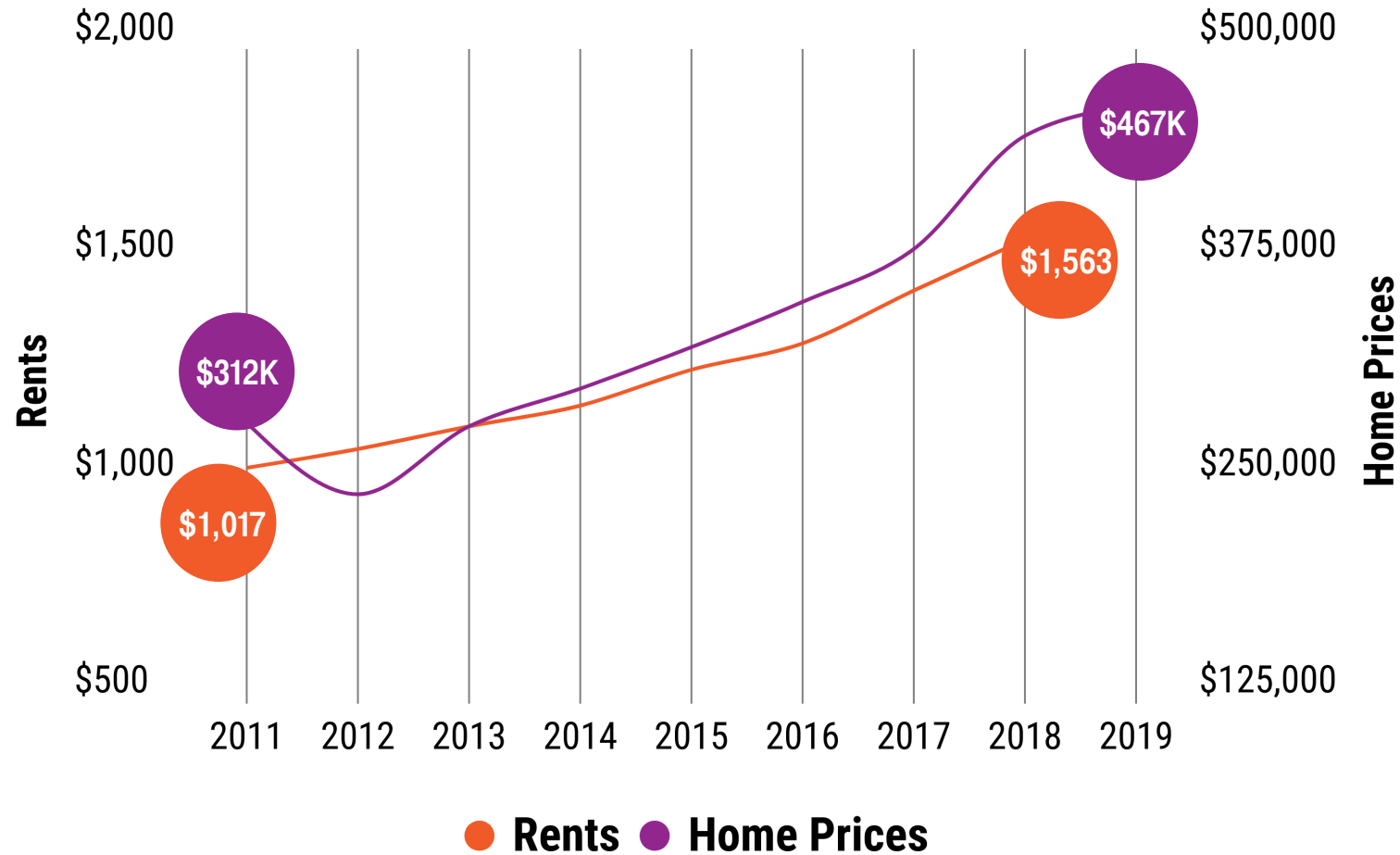

From 2010 to 2018, rents increased 53% and home values increased 67%



# Population growth outpaced housing production for several years

## Annual Population & Housing Unit Trends

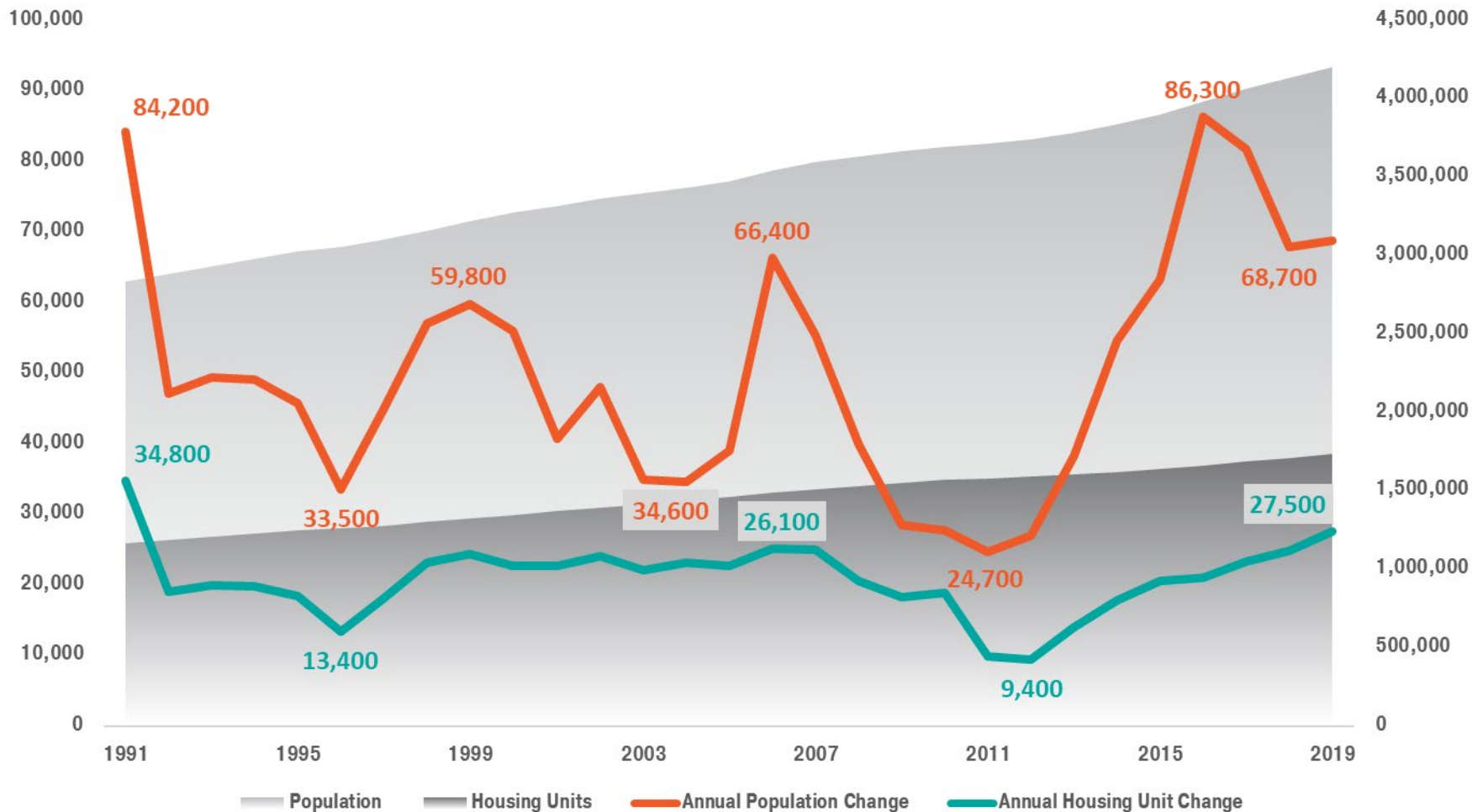

From 2010 to 2019, the region added **3 new residents** for every **1 new housing unit**

# Housing production slowed in the last decade

## Decennial Housing Production

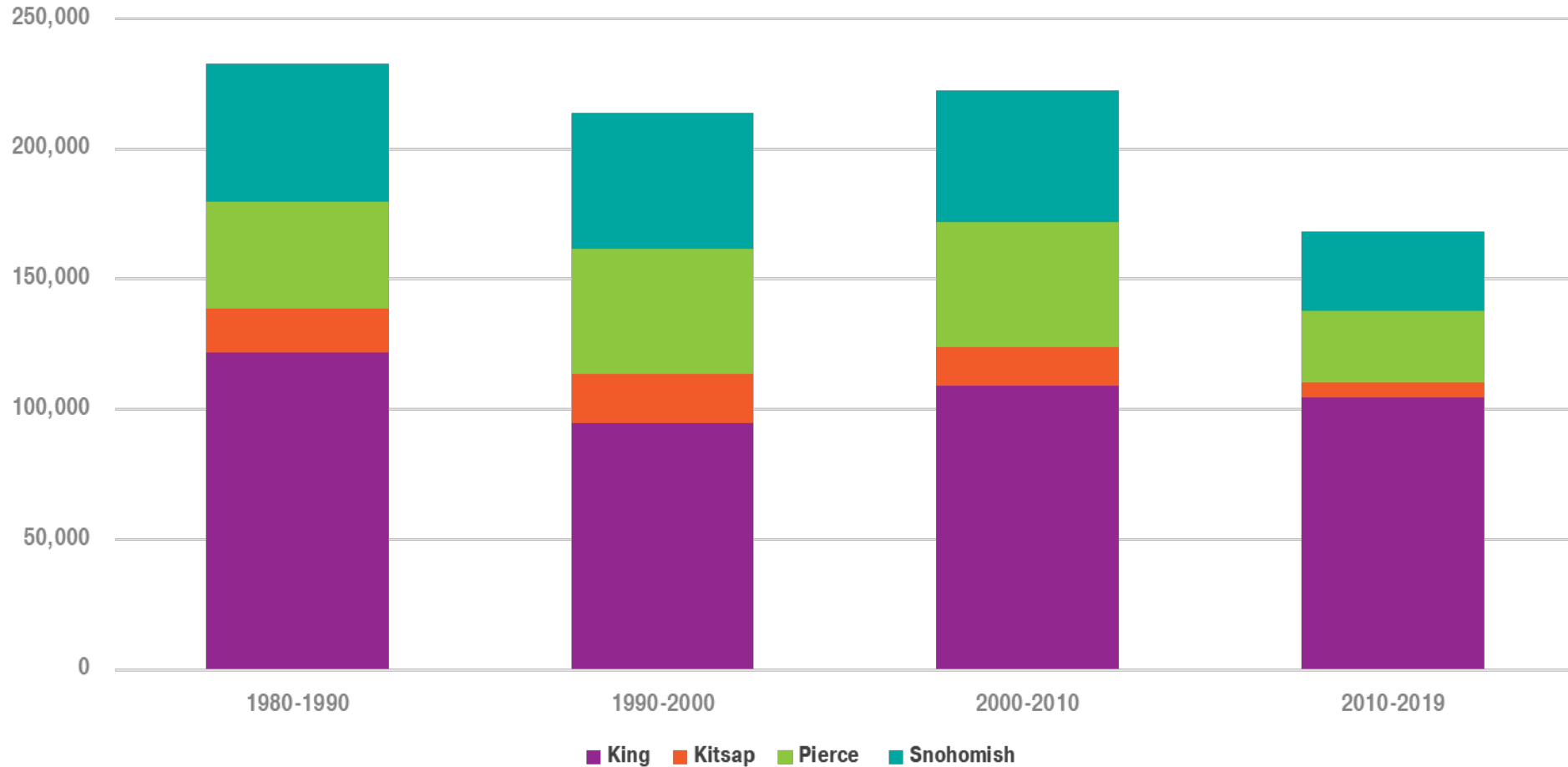

Source: OFM



# Housing production is mostly Multi-Family

## Housing Production by Unit Type

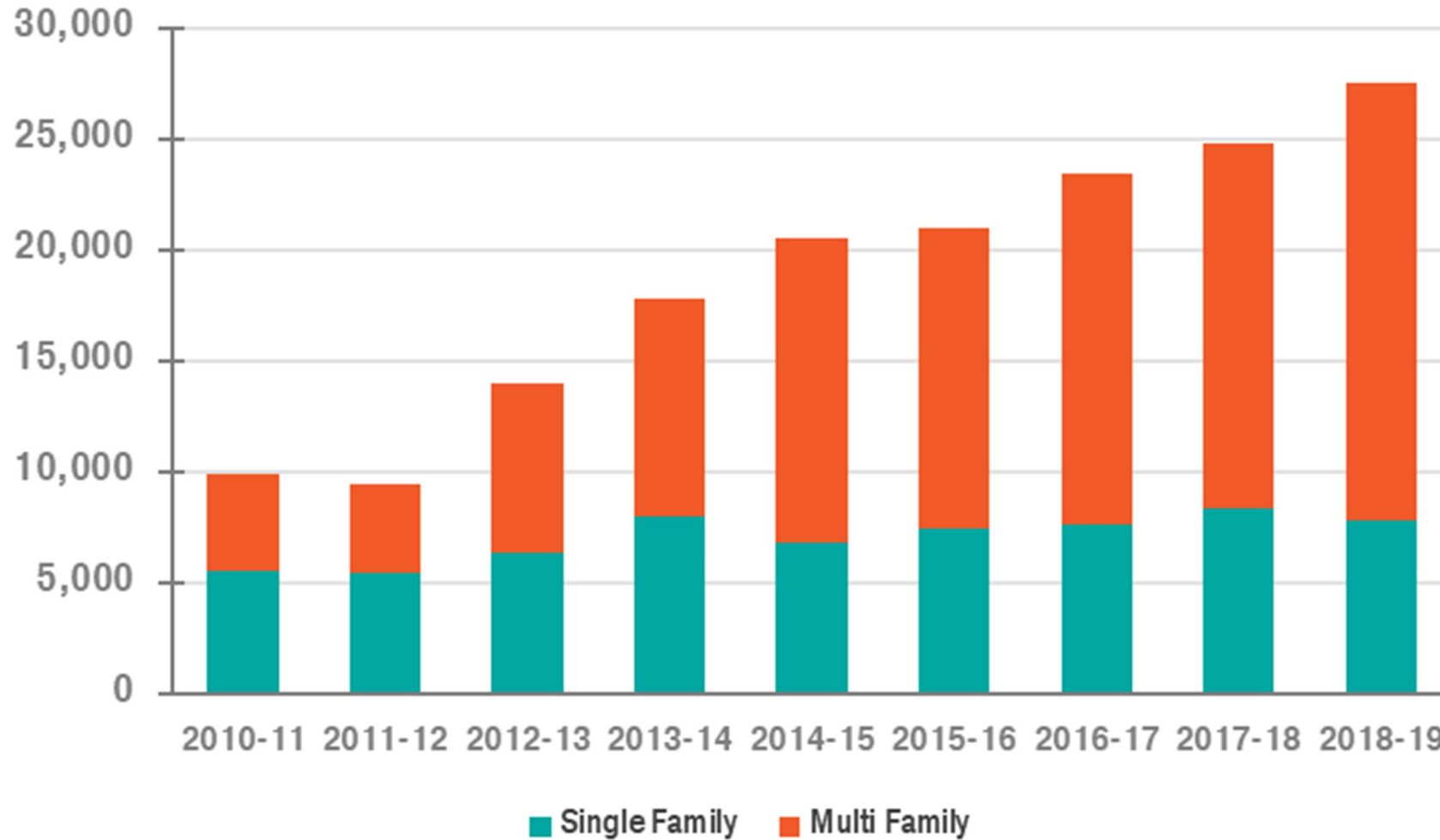

Since 2010, over **124,000 multi-family units** have been added to the region

Source: OFM



# Over 2/3 of Households Don't Include Children



Nearly 2/3 of households are comprised of related people (family households)



Close to 1 in 3 households have children under the age of 18



Over 1 in 3 households include a person over the age of 60

# There is a critical need for more housing across the region

- Housing prices have **risen at an unprecedented rate** over the past decade.
- Strong population and job growth have led to an **increased demand** for housing.
- **One in three households** with less than \$50,000 in income is **severely cost burdened**, spending the majority of their income on housing costs.
- There are substantial disparities between white and person of color households, underscoring the ongoing effects of **systemic racism in housing**.



# Overview of Housing Needs Analysis

**Purpose:** To identify trends and areas where policy interventions are most needed as well as the number of housing units necessary to meet the housing needs of the current and projected population.

## Assess Need in Multiple Ways

- **Supply** – Housing units needed to accommodate projected population, as well as current gap
- **Affordability: Income Level Analysis** – Housing units needed at income thresholds for projected households
- **Affordability: Cost Burden Analysis** – Housing units needed to ensure households do not pay more than 30% of income on housing costs







**How many housing units  
are needed to meet current  
and future demand?**

# Rapid growth and lagging housing production has created a gap in housing needed now

## Annual Population Change vs. Housing Need vs. Actual Housing Change

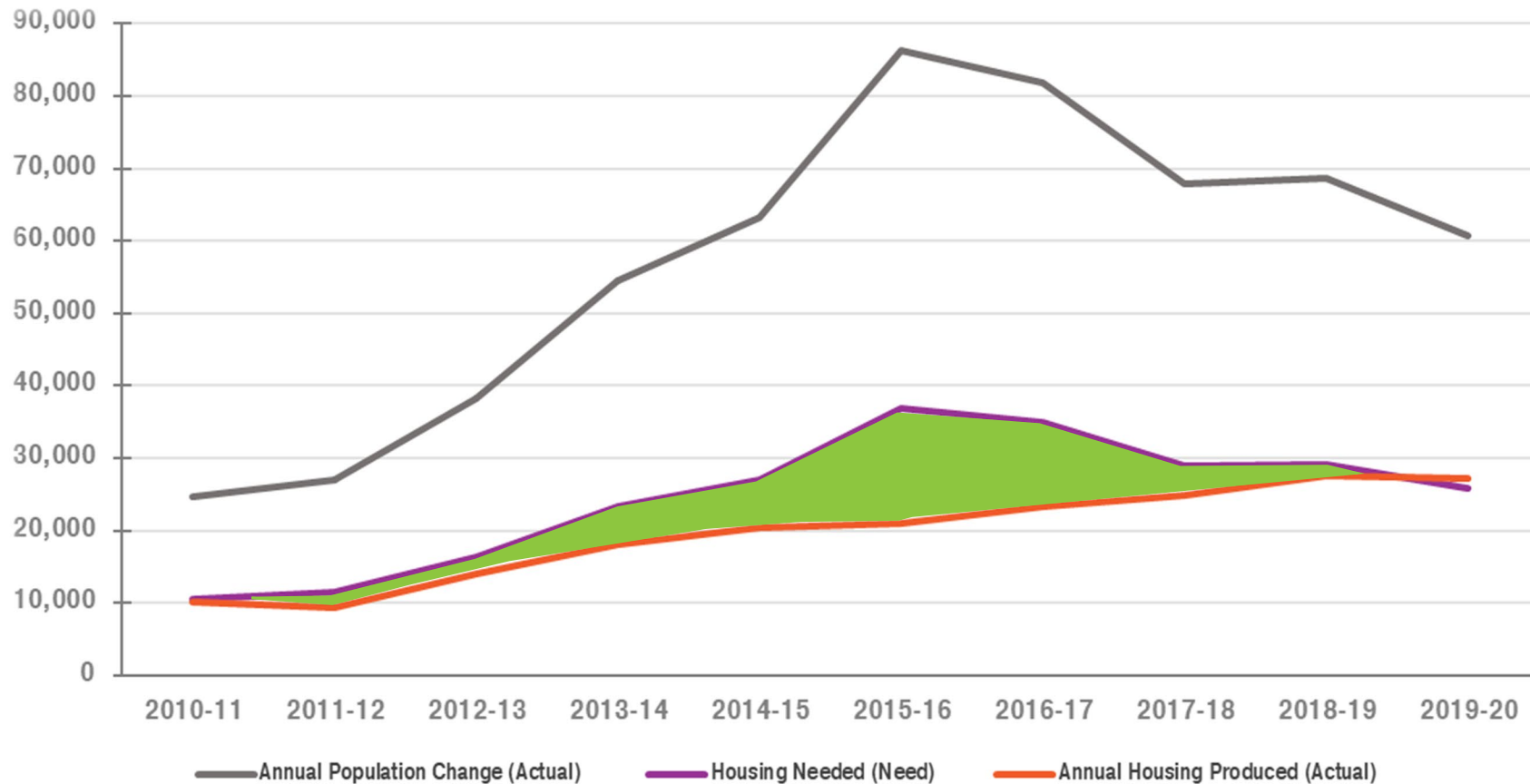

Cumulative Current Gap:  
~48,000

Cumulative current housing gap =  
Actual housing constructed 2010-2020

Estimated 2010-2020 housing need

Source: OFM

# Understanding housing needed for future population growth

*How many new housing units are needed for population growth in the future?*

VISION forecast population for  
2017-2050

x

Average household size  
Vacancy rate  
Population in group quarters

=

888,000 new housing units needed



Update for growth from 2017-2020

**810,000 new housing units  
needed**



# Between 2020 and 2050 the region needs 810,000 additional housing units to accommodate future growth



King County – 418,000 units



Kitsap County – 43,000 units



Pierce County – 161,000 units



Snohomish County – 187,000 Units



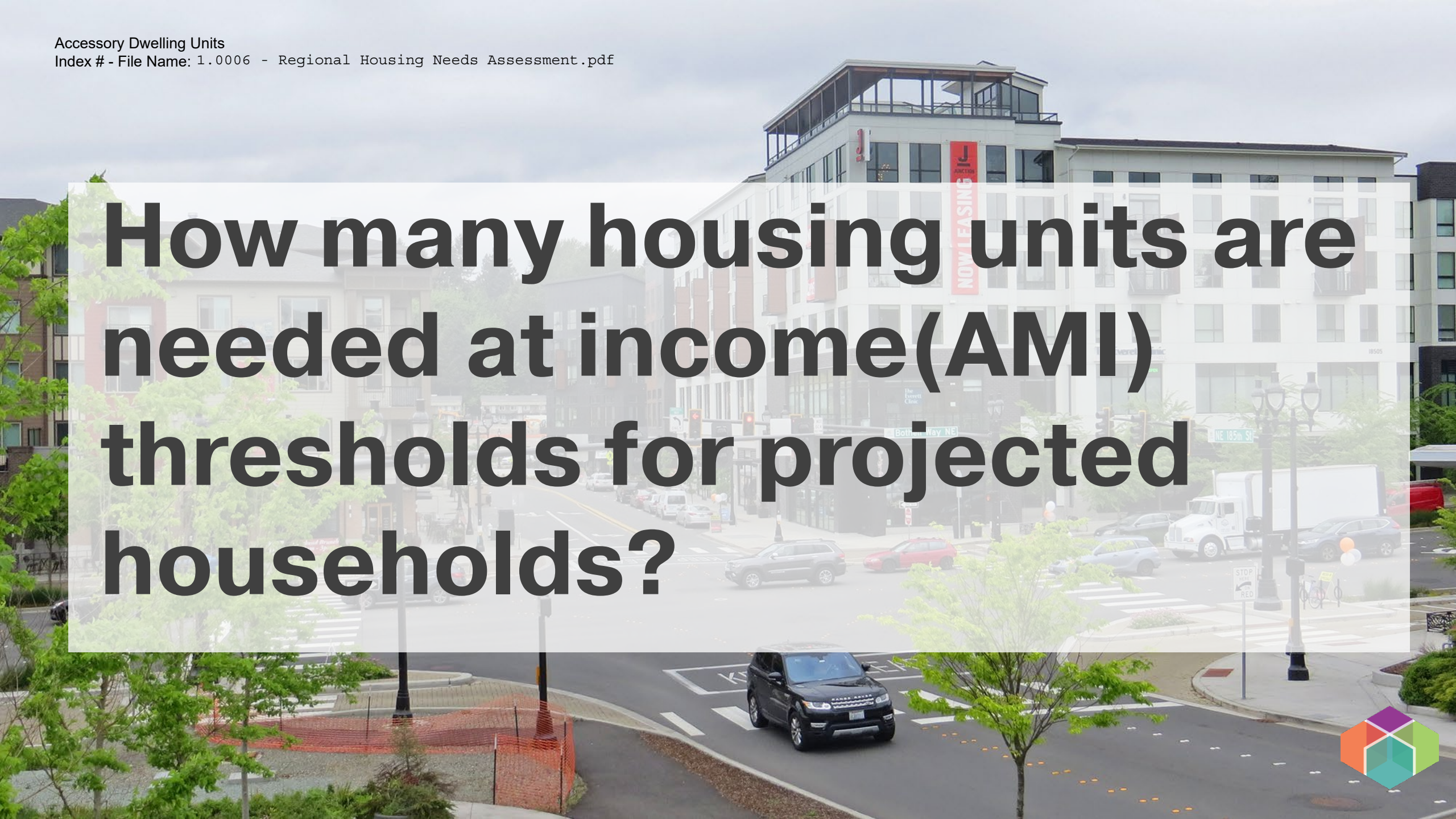

**How many housing units are needed at income (AMI) thresholds for projected households?**



# Different approaches for different needs

## Lower housing costs require greater public intervention

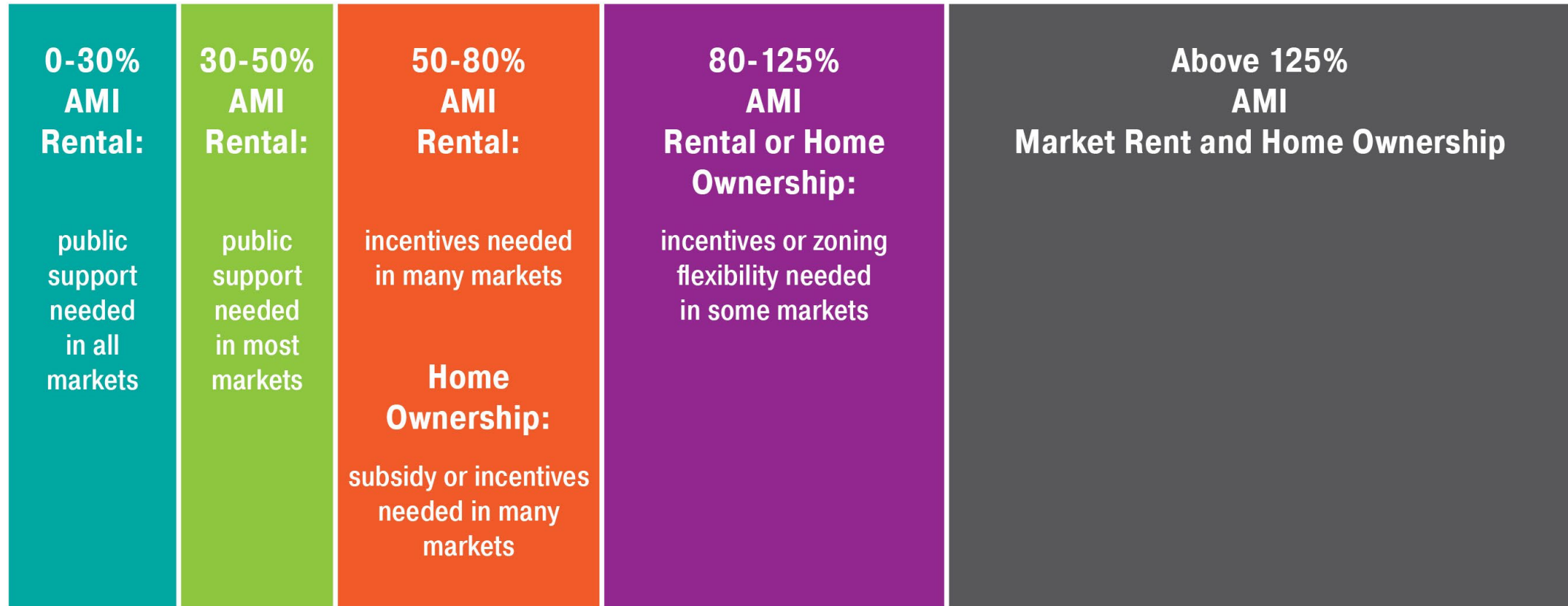

# Over one-third of future units will need to be affordable to moderate and low-income households

Total Housing Units Needed by Income Segment, 2020-2050

	King County		Kitsap County		Pierce County		Snohomish County	
	# Units	% of Units	# Units	% of Units	# Units	% of Units	# Units	% of Units
0-80% AMI	148,000	35%	16,000	37%	60,000	37%	69,000	37%
Above 80% AMI	270,000	65%	27,000	63%	101,000	63%	117,000	63%
<b>Total</b>	<b>418,000</b>		<b>43,000</b>		<b>161,000</b>		<b>186,000</b>	



# Close to 1 in 2 new housing units will require some level of incentive or subsidy to meet affordability needs

## Total Housing Units Needed by Income Segment, 2020-2050

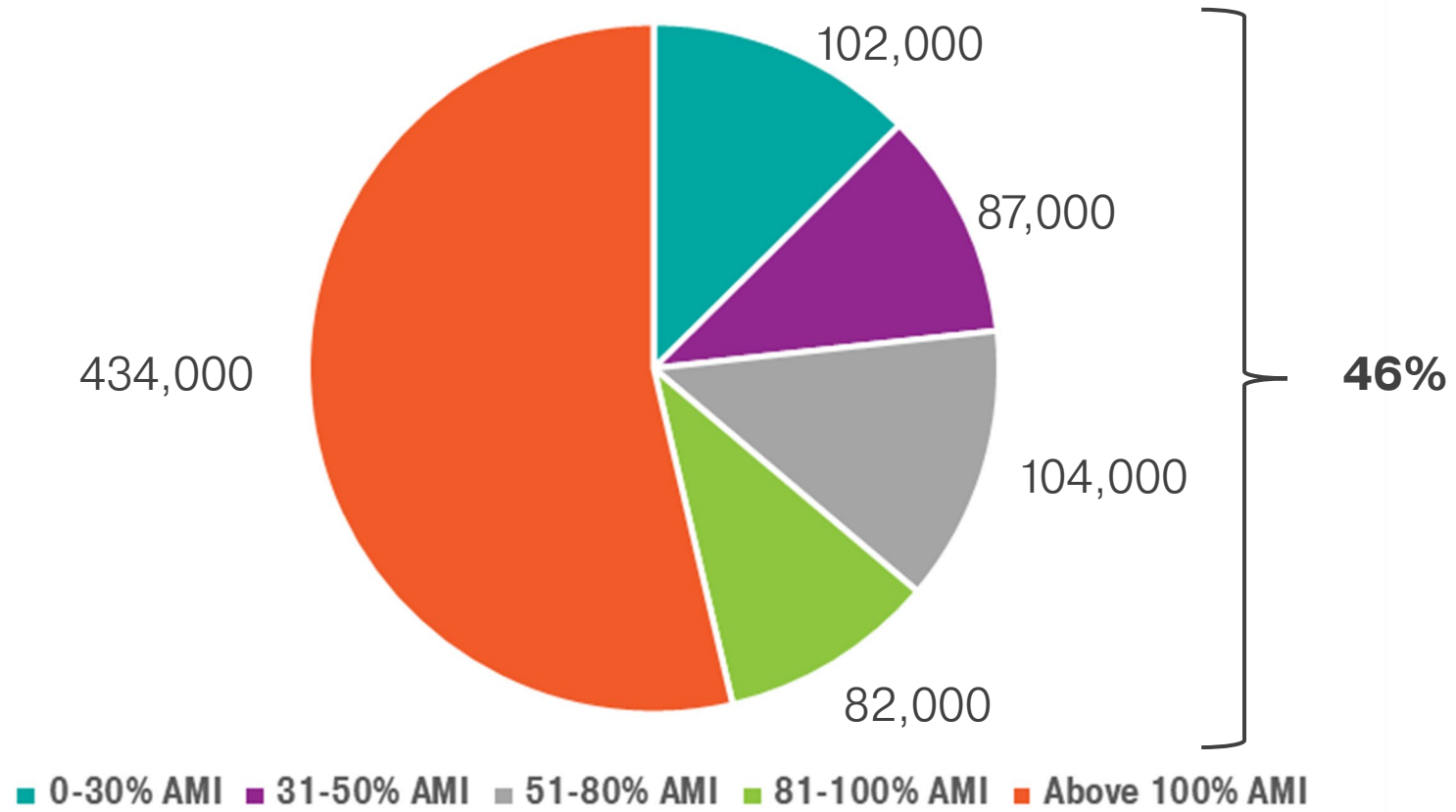



**How many housing units are needed to ensure households do not pay more than 30% of income on housing costs?**



# More than 1/3 of moderate-income households spend the majority of their income on housing

## Cost Burdened Households

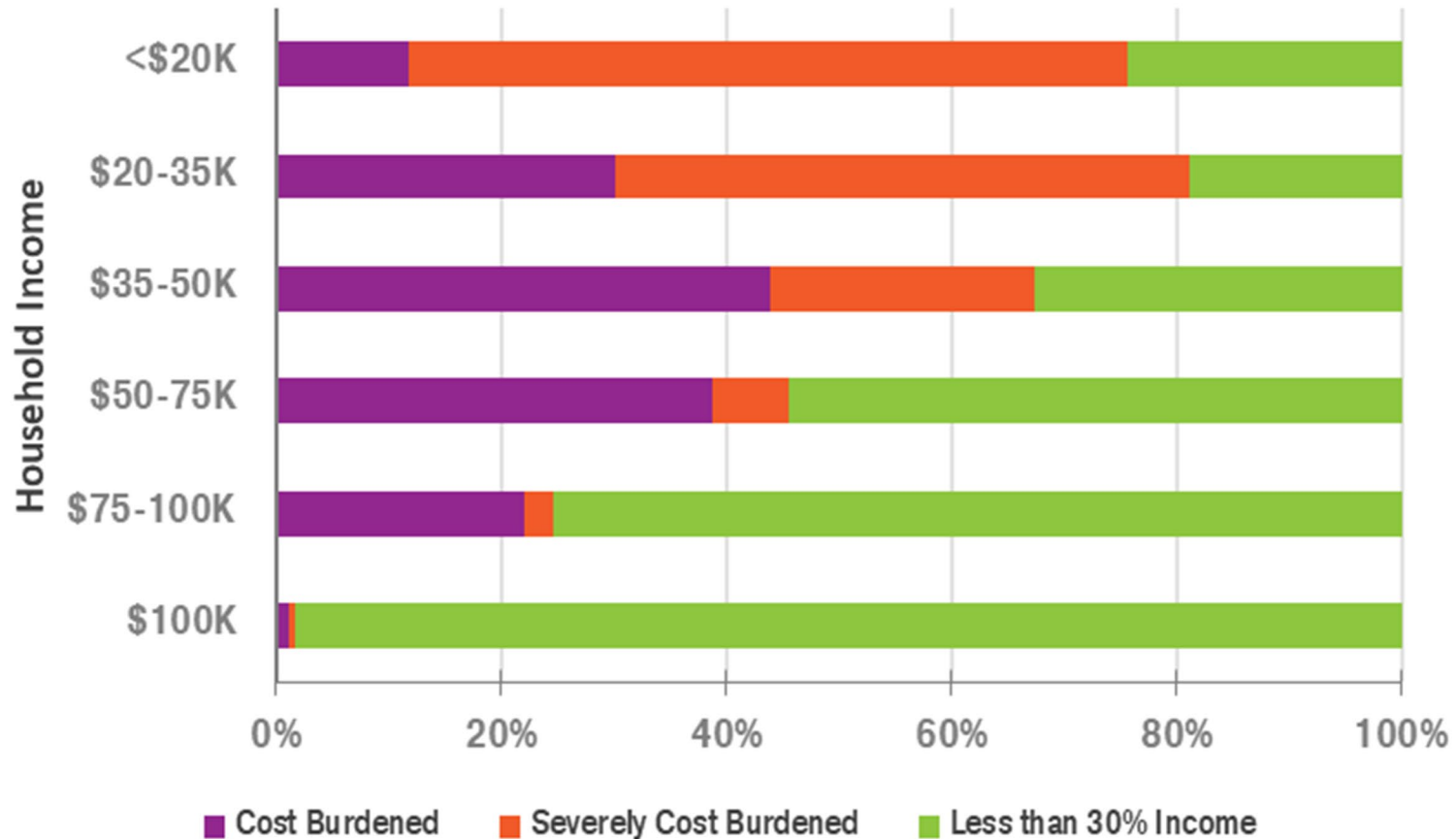

# Calculating Housing Need by Cost Burden

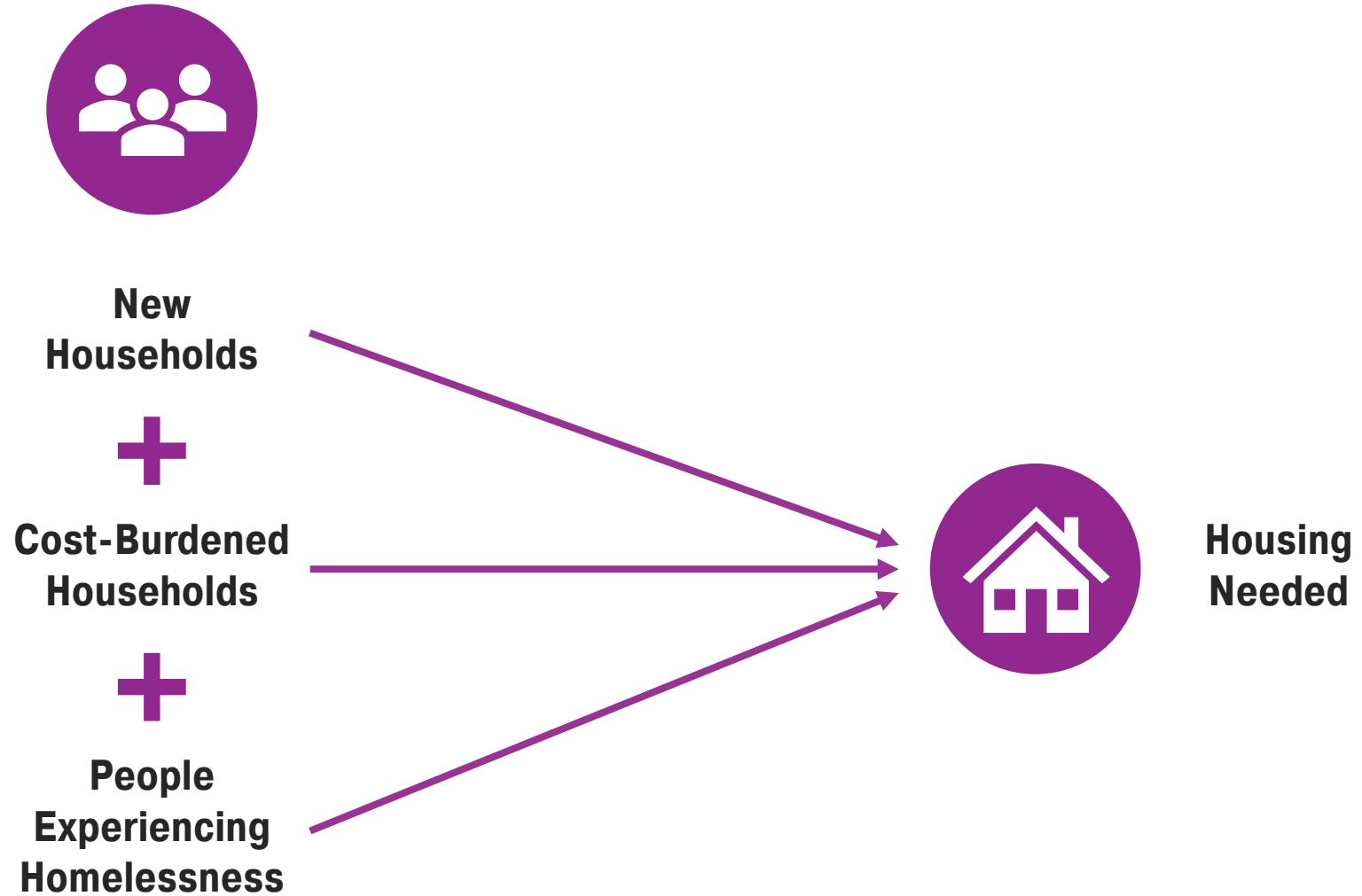

# More than 580,000 units are needed to eliminate *current and future* cost burden

**Current Need**

**283,000** units

**Future Need**

**303,000** units

+

=

**Total Need**

**586,000** new units



# More than 280,000 units are needed to eliminate *current* cost burden

## Current Housing Need

Household by Type	Estimated Homes Required
15,000 people experiencing homelessness	12,000
497,000 cost burdened households	271,000

**57%** of units at or below 30% AMI and to address unhoused people

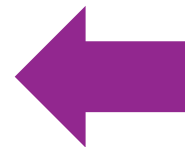

**283,000** housing units now

# More than 300,000 units are needed to eliminate *future* cost burden

## Housing Units Required to Avoid Future Cost Burden, 2017-2050

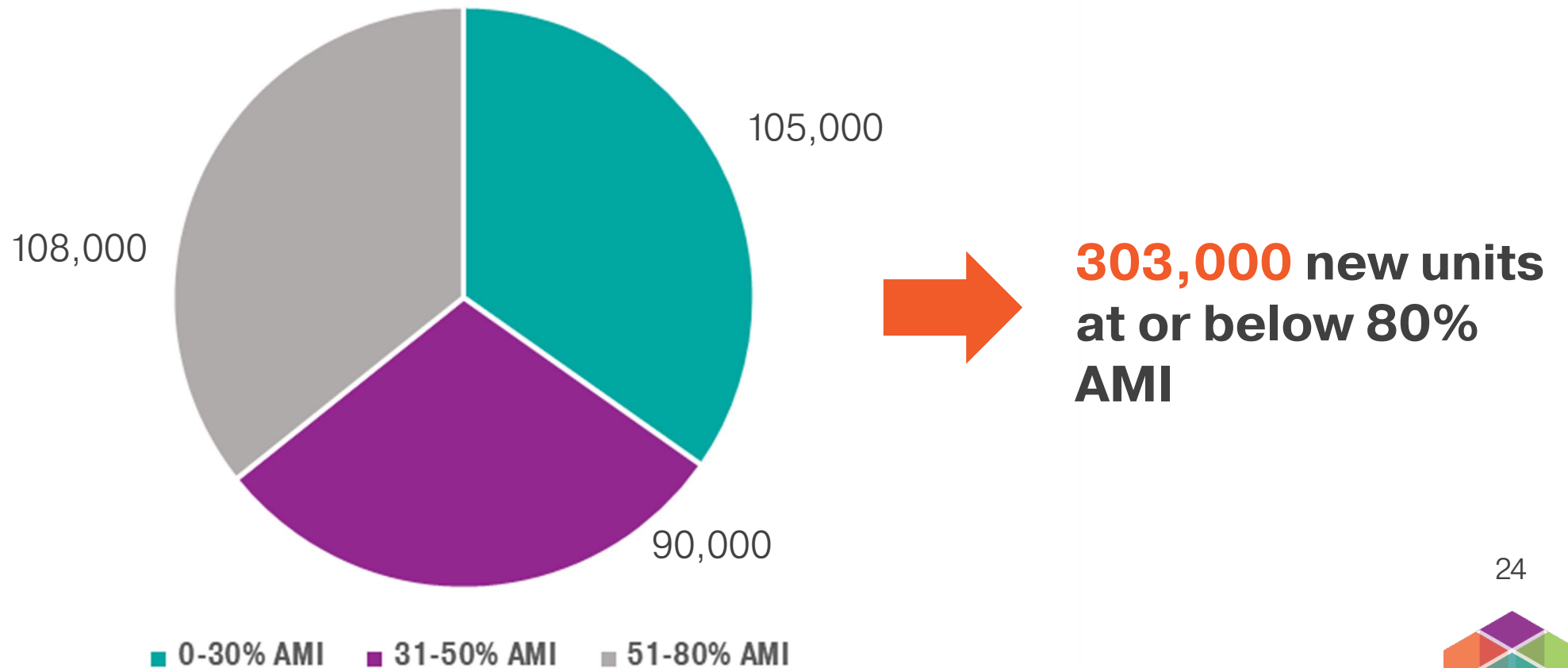

Source: CHAS, Point in Time Counts

# Meeting current and future housing need is a major challenge

- **810,000** housing units needed by 2050
- **303,000** new affordable housing units will be needed to for growth of families at or below 80% AMI
- About **2/3 of new housing** needs to be affordable to fully address current and future housing needs
- Implications for housing size, type, and job and transit access



# Question for the board

- Are there any aspects of housing not covered by the presentation – or identified as forthcoming findings – that would be helpful to address in preparation for future strategy discussions?





# Next Steps

- Additional findings from needs assessment and draft report available late 2020
- PSRC boards and committees will begin discussing potential strategies to address the gaps identified in the RHNA in 2021



Accessory Dwelling Units

Index # - File Name: 1.0006 - Regional Housing Needs Assessment.pdf

**Laura Benjamin, AICP**

**Lbenjamin@psrc.org • 206-464-7134**



**Dolce Si**  
*Sicilian Bakery & Cafe*

**tranquility dental**  
*wellness center*

**Thank you.**



# Accessory Dwelling Units



Model State Act and  
Local Ordinance



A Publication of the  
Public Policy Institute

Rodney L. Cobb and Scott Dvorak  
American Planning Association

**Accessory Dwelling Units:  
Model State Act and Local Ordinance**

**by**

**Rodney L. Cobb, Staff Attorney**

**and**

**Scott Dvorak, Research Associate**

**American Planning Association**

---

**George Gaberlavage, PPI Project Manager**

The Public Policy Institute, formed in 1985, is part of the Research Group at AARP. One of the missions of the Institute is to foster research and analysis on public policy issues of interest to older Americans. This publication represents part of that effort.

The views expressed herein are for information, debate, and discussion and do not necessarily represent the formal policies of AARP.

©2000, AARP

Reprinting with permission only.

AARP 601 E Street, NW, Washington, DC 20049

## **ACKNOWLEDGMENTS**

The authors would like to acknowledge fellow members of the American Planning Association staff who worked on this project. William R. Klein, Director of Research, supervised the project, and Stuart Meck and Jim Hecimovich provided valuable comments and editing on early drafts. We acknowledge the substantial information contributed to the development of this publication by Patrick H. Hare, whose planning firm has played a key role in developing accessory dwelling units in the United States, and by Leo Baldwin, former housing coordinator for AARP.

We are grateful for the assistance provided by state and local officials who gave us important comments on drafts, particularly Barbara Foresti, Program Specialist, Department of Housing and Community Affairs, Montgomery County, Maryland; Terry Sedik, Planning Director, Daly City, California; Holly Gadbow, Senior Planner, Department of Community, Trade, and Economic Development, State of Washington; and Camilla Cleary, Housing Analyst, Department of Housing and Community Development, State of California.

Thanks are also extended to the internal reviewers at AARP: DaCosta Mason, Roy Green, and Don Redfoot. Monique Einhorn, Research Analyst with the Public Policy Institute, took over editorial coordination from Kristin Moag, formerly with the Public Policy Institute. Finally, the authors would like to express their appreciation for the constructive comments and guidance provided throughout this project by George Gaberlavage of the Public Policy Institute.

## TABLE OF CONTENTS

<b>Foreword</b> .....	5
<b>Executive Summary</b> .....	6
<b>Introduction</b> .....	8
<b>Model State Act on Accessory Dwelling Units</b> .....	15
1. General Provisions.....	15
A. Findings.....	15
B. Purposes and Intent.....	16
C. Definitions .....	16
2. General Regulatory Authority .....	17
A. Ordinance Adoption.....	18
B. Criteria for Determining Areas .....	18
C. Approval Process.....	18
D. Imposing Standards.....	18
E. Requiring Owner Occupancy.....	18
F. Less Restrictive Provisions.....	19
G. Maximum or Minimum Size.....	19
H. Use, Density, and Plan Consistency Rules .....	20
3. Limiting Regulatory Authority .....	20
A. Noninterference by Other Law .....	20
B. Exemption from Growth-Limitation Measures .....	20
C. Prohibiting ADUs .....	21
D. Parking Requirements .....	21
E. Fees.....	22
4. Default Provisions .....	22
A. Only Basis for Denial .....	22
B. Maximum Without Local Ordinance.....	22
C. No Changes Necessary.....	23
D. Accommodating Units.....	23
E. Public Notice of Public Official .....	23
F. Standards.....	23
5. State’s Role In ADU Policies.....	25
A. Required Municipal Ordinance Submission.....	25
B. State Certification of ADU Ordinances.....	25
C. Municipal Annual Reports to State.....	26
D. State Annual Report.....	26
E. State Advisory Board on ADU Policies.....	26

<b>Model Local Ordinance on Accessory Dwelling Units</b> .....	28
I. General Provisions.....	28
1. Purpose & Intent.....	28
2. Definitions.....	29
II. Permits: Eligibility and Application.....	29
3. Authorization for ADUs by Zoning District.....	29
4. Approval Process.....	32
5. Application Fees and Information.....	33
6. Permit Renewal (Monitoring).....	34
III. Standards.....	35
7. Lot Standards - Occupied by Dwelling Unit.....	35
8. Lot Standards - Minimum Size.....	36
9. Lot Standards - Setback and Lot Coverage.....	37
10. Occupancy Standards - Owner of Premises.....	37
11. Occupancy Standards for ADUs.....	39
12. Principal Dwelling Unit Building Standards - Minimum Floor Area.....	40
13. Principal Dwelling Unit Building Standards - Age.....	40
14. Principal Dwelling Unit Building Standards - Term of Ownership.....	41
15. ADU Building Standards - Architectural Design and Types of Structures.....	42
16. ADU Building Standards - Orientation of Entrance.....	42
17. ADU Building Standards - Size.....	43
18. ADU Building Standards - Not Intended for Sale.....	44
19. ADU Building Standards - Screening and Orientation.....	45
20. Parking and Traffic.....	45
21. Public Health.....	47
22. Density Limits.....	48
23. Legalizing ADUs.....	49
<b>References</b> .....	52
<b>Resource Guide</b> .....	54

## FOREWORD

Accessory dwelling units (ADUs) are independent housing units created within single-family homes or on their lots. These units can be a valuable addition to a community's housing stock. ADUs have the potential to assist older homeowners in maintaining their independence by providing additional income to offset property taxes and the costs of home maintenance and repair. Other potential benefits include companionship, the opportunity to negotiate for home maintenance or personal services in return for reduced rents, and increased personal security. ADUs also offer a cost-effective means of increasing the supply of affordable rental housing in a community without changing the character of a neighborhood or requiring construction of new infrastructure such as roads, sewers, and schools. Zoning ordinances that prohibit ADUs or make it extremely difficult for homeowners to create them are the principal obstacle to the wider availability of this housing option.

The Public Policy Institute of AARP asked the American Planning Association (APA) to develop model legislation (a state statute and a local ordinance) that would assist AARP volunteer leaders and other interested citizens, planners, and government officials in evaluating potential changes to state laws and local zoning ordinances to encourage the wider availability of ADUs. The APA is the nation's leading source of information on planning and zoning practices. Rodney L. Cobb, APA's Staff Attorney and Editor of *Land Use Law* and *Zoning Digest*, was the principal investigator for this project. He was assisted by Scott Dvorak, Research Associate, and other members of APA's research department. The authors have drawn heavily from the experiences of states and localities in developing the model legislation. As a result, many of the provisions incorporated in the model legislation have been tested in different communities and proven successful in actual practice.

The model legislation is intended to serve as a guide for communities that want to make the benefits of ADUs available to households of all ages, not just older persons. It has been drafted to meet the needs of a wide variety of communities. Optional provisions, including those that are attractive even to very cautious communities, are incorporated in the model local zoning ordinance to provide as many choices as possible for jurisdictions to consider. The materials presented here indicate that ADUs can be a cost-effective solution for meeting myriad housing needs without engendering the negative impacts sometimes associated with other forms of affordable housing development. It is our hope that the model legislation will prove to be a valuable reference for communities seeking to increase the housing choices available to their residents.

George J. Gaberlavage  
Associate Director/Consumer Team  
Public Policy Institute



## EXECUTIVE SUMMARY

### Background

Accessory dwelling units (ADUs) are independent housing units created within single-family homes or on their lots. They have the potential to assist older homeowners in maintaining their independence by providing additional income to offset property taxes and maintenance and repair costs. Other potential benefits to older homeowners include companionship, the opportunity to negotiate for home maintenance or personal services in return for reduced rents, and increased personal security. ADUs also offer a cost-effective means of increasing the supply of affordable rental housing in a community without changing the character of a neighborhood or requiring construction of new infrastructure (roads, sewers, schools, etc.) to serve development. Zoning ordinances that prohibit ADUs or make it extremely difficult for homeowners to create them are the principal obstacles to the wider availability of this housing option.

### Purpose

The purpose of this report is to present model legislation for both states and local jurisdictions to use to develop their own regulations on creating ADUs. Drawing on the experience of communities that have incorporated ADUs into their zoning practices, the report reviews and evaluates potential options for changes in state laws and local zoning ordinances to increase the availability of ADUs.

### Methodology

A search was conducted to collect and review existing literature on ADUs, including all state ADU legislation, local ADU ordinances, and ADU court cases. In addition, a mailing went out to some 1,600 planning agencies and consultants who subscribe to the American Planning Association's *Zoning News*, requesting copies of local ADU ordinances and information on ADU policies and regulations. (These activities took place in 1996 and 1997, with an additional review conducted in 1999 of ADU state legislation and court cases.) The researchers then analyzed the 50 local ADU ordinances and other materials collected in response to the mailing. A series of follow-up interviews with state and local officials and ADU experts were then conducted to develop further information on the key ADU issues raised by the analysis. To obtain a broad national perspective, these interviews were conducted with officials in a variety of regions and states. The Model State Accessory Dwelling Unit Act and the Model Accessory Dwelling Unit Ordinance were then drafted. Several state and local officials interviewed earlier subsequently reviewed the draft model legislation to assess its utility and feasibility in light of actual administrative practice and community experience.

## **Principal Findings**

Regulatory barriers can be most effectively removed by adoption of a state ADU act and by encouraging localities to adopt ADU ordinances. Many communities that initially allowed limited ADU development found the experience positive enough to broaden the scope for ADUs.

## **Conclusion**

Reductions in the size of American households, along with changes in their composition and economic circumstances, warrant consideration of zoning policies that encourage the more efficient use of the nation's infrastructure and supply of single-family homes to meet current and future housing needs. States and localities are also seeking ways to assure the independence and security of older residents with a minimum of public investment. ADUs provide a potential resource for addressing these issues by making more effective use of existing housing stock and providing older homeowners with a potential source of income to maintain their independence.

## INTRODUCTION

Across the United States, communities are struggling to meet the nation's growing and changing housing needs. Three factors — changing demographics, changing economics, and changing community goals — have converged to make innovative solutions to housing issues a policy necessity.

- **Changing demographics.**  
American families are growing in number but shrinking in size. People are living longer, more people are staying single longer, and married couples are having fewer children. The housing stock has not kept up with this change in family demographics. In some communities, the need for housing, especially for people with special physical and financial needs, has become acute. Underused space in single-family houses is one of the nation's largest untapped housing resources.
- **Changing economics.**  
Not only is family size changing, but so are the economic circumstances of families. As the population ages, many older people find themselves living in their family homes alone. They may need additional income to pay for health care services, cover home maintenance costs, or make mortgage payments. Others may want a family member or a caretaker to live nearby, while maintaining privacy for both parties.
- **Changing community goals.**  
Many communities have recognized the need to stabilize or increase population densities in certain areas in order to maintain the existing public infrastructure, services, and tax base. In addition, many communities have sought to concentrate population density in specific areas in order to encourage public transit service and reduce urban sprawl. These communities do not, however, necessarily want their single-family neighborhoods to become structurally more dense.

One approach to meeting these needs is to allow or even encourage the development of accessory dwelling units (ADUs). ADUs are constructed as either apartments or cottages, and the term "ADU" is used in this publication to include both types of accessory units. The relationship of the ADU to the single-family home, or "the principal dwelling unit," determines the type of ADU. An *accessory apartment* is built within the principal dwelling unit, whereas an *attached accessory cottage* is physically connected to that dwelling unit. A *detached accessory cottage* is located on the same lot as the principal dwelling unit but is not physically connected.

ADUs offer the potential for assisting older homeowners and others in maintaining their independence while increasing the supply of affordable rental housing within a community. Income from an ADU can offset rising property taxes, maintenance and repair costs, and other housing expenses that are often a burden for older homeowners. ADUs can also make it easier for households with children to afford the housing they need. In some situations, an ADU may

provide enough additional income so that a family can afford to buy a house in a preferred neighborhood that is safer, has better schools, or is closer to work.

Currently, ADUs are not a widely available housing option in the United States. Local zoning ordinances that prohibit ADUs or make it difficult for homeowners to create them are the principal obstacle. Although the impacts on neighborhoods from developing ADUs are minimal compared to those of other types of affordable housing, residents are often concerned about ADUs' compatibility with neighborhood character and design, the impact on parking, and the effects on property values and community services (see Sidebar A).

Yet, what today is called an accessory dwelling unit was once a rather typical housing arrangement. ADUs were relatively common before World War II. Many accessory units were created by middle-aged and older persons, often widows, seeking to take in roomers or boarders after their children moved out. Following the war, however, the explosive growth of the suburbs was guided by zoning ordinances that focused almost exclusively on the housing needs of the traditional nuclear family, and most communities prohibited ADUs.

Ironically, those same suburban homes were frequently constructed with unfinished space, so that homeowners could modify their living space as their needs changed. Many of these suburban homes have had additions and modifications — bedrooms, finished basements, and recreation rooms to accommodate growing families — over the past 50 years.

Current zoning ordinances, however, often maintain rigid prohibitions against ADUs. These ordinances now limit the expansion and modification options of homeowners and prevent communities from making effective use of their current housing stock to meet the changing needs of families. For older persons living in the suburbs today, the inability to continue to adapt their homes to suit their needs may mean they cannot “age in place.” Yet, consumer preference surveys conducted by AARP consistently indicate that 80 percent or more of older households would like to remain in their current homes.

In addition, a recent AARP housing preference survey of persons 50 and older indicated that over one-third of the respondents (36 percent) would consider modifying their home to include an ADU in the event they needed assistance as they grew older. The potential for construction of ADUs by older homeowners is significant. The latest American Housing Survey (1997) revealed that some 16.5 million older households (age 65 and older) own their homes, and single-family detached homes make up 88 percent of these units. This survey indicates that these homes could accommodate accessory units. Single-family detached dwellings among homeowners age 65 and older (including mobile homes) had a median area of 1,665 square feet.

In fact, though ADUs are illegal in many U.S. communities, some homeowners create them anyway. Since creating an accessory apartment does not require any changes to the outside of the dwelling, an illegal unit is not likely to draw the attention of local officials. Overall, ADUs are an important part of annual additions to the nation's housing stock; it is estimated that between 65,000 and 300,000 such units are created each year (Howe 1990, 70).

**Sidebar A. DALY CITY, CALIFORNIA**

In 1979, Daly City officials, like many civic leaders in the San Francisco Bay area, were concerned about the lack of affordable housing. To help remedy the problem, city officials offered to acquire land and build a public housing project. After a hearing with 400 residents, many of them protesters, the project did not go forward. City officials were still searching for answers to the affordable housing problem when the California legislature passed a law in 1982 pushing local governments to adopt ADU regulations. In 1983, Daly City passed its own ADU ordinance, citing three reasons: to help meet housing needs, to conform to the state legislation, and to legalize illegal ADUs that posed health and safety hazards to residents.

Before launching its ADU program, Daly City officials were worried that too many ADUs might cause nuisances, parking problems, and demands too great for existing community services. The city established a number of requirements to meet these concerns. Because small lots dominate the city's neighborhoods, only accessory apartments, not detached units, were allowed in residential zones. Four parking spaces were required on premises with an ADU, with two being for the principal unit. These spaces, however, could be accommodated with tandem parking (one car in front of another in driveways) and could be located in any area of the yard. Daly City also limited the maximum size of an accessory apartment to 25 percent of the living area of the principal dwelling unit.

A further city requirement that owners occupy the premises has proven critical to preventing nuisances. Officials reasoned that with the ADU owners on the premises, many nuisances that tenants might otherwise create would not be tolerated. Although realtors have tried to repeal the owner-occupancy requirement, Daly City officials have made it clear that an owner's presence on premises with an ADU is a must.

A cornerstone of Daly City's ADU program is its Project Homesafe, which received an award from the California League of Cities as an innovative community development program. This project was initiated by the city in 1992 to rid neighborhoods of fire and structural risks posed by illegal ADUs that did not conform to building and electrical codes. Out of an estimated 5,000 illegal units, 1,055 have been legalized, meaning that many safety hazards have been eliminated.

In addition to legalizing existing ADUs, the city's efforts have led to the creation of 288 new legal units. Early in its ADU program, the city sowed the seeds of success in fostering new units by minimizing applicant fees and red tape. It charges only \$100 for ADU application fees, which is even less than the fee required to add a bedroom to a house. To cut red tape, the city designed a process that takes about 20 minutes. An applicant describes the particulars of his proposal and may then obtain a preliminary approval. A hearing is not required. Permits are permanent, and conditions (like the owner-occupancy requirement) are recorded in the title to the property in order to notify subsequent owners of the conditions. The city also promotes new ADUs with a low-interest loan program for low-income owners who agree to install ADUs and to lease the units only to other low-income persons for a period of at least five years.

Other advantages of Daly City's ADU program are at the human level — in its social benefits. Many senior citizens who were empty nesters living on fixed incomes were able to create accessory apartments, live in them, and rent out the remainder of their homes to persons who often became part of their extended family. One homeowner with Alzheimer's was able to trade ADU quarters for medical services from an ADU tenant, a nurse, who was also delighted by the arrangement. The city's young citizens have gained from ADUs because Bay Area housing costs are quite high and one viable option for them is to rent an ADU. For some laid-off blue-collar residents, ADU rental income has actually allowed them to keep their homes.

The model legislation contained in this publication authorizes and provides guidelines for all forms of accessory units. The *model state act* provides the justification and authorization for ADUs and establishes rules that local officials must follow in adopting a local ADU ordinance. The *model local ordinance* offers provisions that local officials can include in their existing zoning ordinance to specify what a homeowner must do to obtain a permit to build an ADU. The model local ordinance is intended to be implemented in tandem with the model state act.

Resources searched or consulted to develop the model acts include all existing American state ADU legislation, model ADU ordinances, and ADU court cases. These sources are noted in parentheses in the text of the model legislation, and a complete reference list appears at the end of the document.

### The Model State Act on Accessory Dwelling Units

The model state act sets the terms for what communities can and cannot do in regulating ADUs via local ordinances. It consists of five sections:

1. General Provisions

Section 1 establishes as state policy the encouragement of ADUs in a manner that enhances residential neighborhoods. This section incorporates the act's findings, purposes, and definitions of terms.

2. Regulatory Authority

Section 2 authorizes localities to adopt ADU ordinances and specifies the powers they may exercise in regulating ADUs. This section authorizes local governments to allow ADUs in single-family or multi-family zoning districts; to require that either the ADU or the principal dwelling unit be owner-occupied; to impose standards with regard to parking, height, setback, lot coverage, architectural review, and other considerations; to define the application procedure for creating ADUs; and to set maximum and minimum sizes for attached and detached ADUs.

3. Limiting Regulatory Authority

Section 3 prohibits localities from regulating ADUs in ways that violate the intent of the act. This section requires localities to justify bans on ADUs, exempts ADUs from growth-limitation measures, and establishes guidelines for parking requirements and fees that localities may impose.

4. Default Provisions

Section 4 establishes procedures and standards for obtaining a permit to create an ADU if a locality does not adopt an ADU ordinance. This section prohibits localities that do not have an ordinance in place from imposing standards beyond those in the state law. Section 4 also requires publication of a quarterly notice indicating the availability of the public official responsible for processing ADU permits.

5. State's Role in ADU Policies

Section 5 presents the option of giving the state a stronger role in encouraging ADUs. This section authorizes state review and certification of local ADU ordinances, collection of data on local ADU efforts, preparations of a State Annual Report that would make recommendations to the legislature and governor for improving the ADU act, and creation of a State Advisory Board on ADU policies.

Italicized notes are included in the text to assist readers in understanding various provisions of the act. Some of the explanations refer to the related model ADU local ordinance, which is designed to complement the model state act.

The Model Local Ordinance on Accessory Dwelling Units

The model local ordinance is designed to implement the policies of the model state ADU act. It will also help guide communities in drafting their ADU ordinances, even if the state does not have legislation governing ADUs. It attempts to balance the need to specify clear, rigorous standards that protect the community with the need to avoid requirements so onerous that no one will apply to install an ADU.

The ADU ordinance specifies what a homeowner must do to get a permit to build or create an ADU. Typically, a community adopts an ADU ordinance as an amendment to its zoning ordinance. (Some local governments refer to zoning regulations as “codes” or “bylaws” or “unified development regulations.”)

The provisions of the model local ADU ordinance are organized into the following three categories:

1. General Provisions

Section 1 establishes that the purpose of the ordinance is to promote and encourage the creation of legal ADUs in a manner that enhances residential neighborhoods. Section 2 provides a definition of terms.

2. Permits: Eligibility and Application

Sections 3 through 6 inform homeowners of the steps they must take to obtain, keep valid, and renew an ADU permit. In addition, these sections specify what types of proposed ADUs (apartments, attached or detached cottages) are eligible for permits in various zoning districts.

3. Standards

Sections 7 through 23 specify standards that a homeowner's application must meet before a permit to build or create an ADU is approved. These standards address the issues of lots (Sections 7 through 9), occupants (Sections 10 and 11), building standards (Sections 12 through 19), parking and traffic (Section 20), public health (Section 21), density limits (Section 22), and legalizing illegal and nonconforming ADUs (Section 23).

In the model local ordinance, the duplication of general zoning provisions is avoided because communities typically adopt an ADU ordinance as part of their general zoning ordinance or code. For this reason, the model local ADU ordinance does not contain provisions setting up zones or laying out application and enforcement procedures, and it does not provide routine definitions of basic zoning ordinances (such as definitions of “permit” or “lot”). It is assumed that the general zoning ordinance of which this model local ordinance will become part provides that all building construction is subject to the range of other typical community laws — e.g., building codes, fire codes, electrical codes, and housing codes.

The model local ADU ordinance presents options for dealing with key ADU issues. These options acknowledge that conditions vary in different communities. They are evaluated as “optimal,” “favorable,” or “minimal” (see below), based on their potential to increase the availability of ADUs in a community. For each option, a commentary is provided about the issues involved. Some comments are predicated on the assumption that the model local ordinance is adopted in a state that has already enacted a state accessory dwelling unit law.

1. Optimal

Provisions labeled “optimal” provide the fewest restrictions on the development of ADUs;

2. Favorable

Provisions labeled “favorable” address the concerns of the legislative body and neighbors while imposing relatively modest requirements for the installation of ADUs;

3. Minimal

Provisions labeled minimal address the concerns of the legislative body and neighbors but in a manner that is likely to reduce the potential incentives for homeowners to create ADUs.

Sorting among these provisions will allow policymakers and community members to draft ordinances that reflect their desires and concerns. Historically, communities have tended to adopt somewhat strict standards in the beginning and then to amend their ordinances with standards that more readily encourage homeowners to develop ADUs (Hare 1989, 17-18). The research conducted for this report indicates that the fear of negative impacts is greatly diminished as local officials and neighbors have the opportunity to see firsthand the benefits of ADUs for citizens. Given this experience, many communities may become interested in increasing the number of ADUs (see Sidebar B).



**Sidebar B. MONTGOMERY COUNTY, MARYLAND**

Like many rapidly developing suburban counties, this area outside of Washington, DC has experienced a tremendous increase in the cost of housing. With this increase in cost comes more restricted access to housing for people of low and moderate incomes. To address this problem, the county established a committee in 1983 to study how to use the existing housing stock more efficiently. One of the study results was the adoption of an accessory apartment ordinance in 1984. Since then, more than 600 special-exception applications have been submitted for accessory apartments. By 1996, the county had about 400 legal accessory apartments; since 1989, more than 360 affidavits of compliance for registered units have been filed for rent-free units used by relatives or in-home workers.

To ensure acceptance of the original ordinance, the county was very careful about establishing the criteria under which it would allow accessory apartments. The ordinance has since been amended seven times for various reasons, including allowing ADUs in cellars, reducing lot-size minimums, requiring the posting of signs when a house with an accessory apartment has been sold and the new owner intends to maintain the accessory apartment, and eliminating the requirement for an annual status report to the county council. The county found that requiring a minimum lot size is a good idea; however, the minimum lot did not need to be as large as officials initially thought.

As in any community, residents were concerned with neighborhood quality, particularly property values and parking. Montgomery County addresses these issues by requiring two off-street parking spaces or proof of adequate on-street parking and by limiting the number of accessory apartments approved in any one neighborhood. Officials have not established a hard-and-fast rule for accessory apartment spacing, but it has used a guide of no more than two units on any one block. The county also requires that owners occupy the premises.

In order to ensure the success of its accessory unit program, the county published a guidebook in 1991 designed to assist applicants seeking permits for accessory apartments. The book details who is allowed to construct an accessory apartment, the information needed to obtain a permit, and what to expect during the application process. The Montgomery County accessory apartment program started with thorough research backing up the need for this type of housing, followed by an ordinance that addressed the main concerns of residents but could be amended as needed. The county government supported the ordinance by publishing guides to getting accessory apartments approved and by maintaining on staff a program specialist responsible for coordinating the program and assisting the public.

## MODEL STATE ACT ON ACCESSORY DWELLING UNITS

### 1. General Provisions.

#### A. Findings.

The Legislature finds and declares that:

- i. There is a large and growing unmet need for affordable housing to shelter the State's population. (Cal. Stats. 1982, ch. 1440 Section 1);
- ii. The State's existing housing resources, particularly single-family dwelling units, are vastly underutilized due in large part to the changes in social patterns. The improved use of this state's existing housing resources offers an innovative and cost-effective solution to the State's housing crisis (Cal. Stats. 1982, ch. 1440 Section 1);
- iii. The State can play an important role in increasing the use of existing housing resources and in reducing the barriers to the provision of affordable housing (Cal. Stats. 1982, ch. 1440 Section 1);
- iv. Typical installation rates of accessory dwelling units (ADUs) are low, rarely exceeding one ADU per 1,000 single-family homes per year (Hare 1989, 1); and
- v. There are many benefits associated with the creation of legal ADUs on single-family lots (Cal. Stats. 1982, ch. 1440 Section 1). These benefits include:
  - (1) Providing a cost-effective means of accommodating development by making better use of existing infrastructure and reducing the need to provide new infrastructure (Cal. Stats. 1982, ch. 1440 Section 1);
  - (2) Increasing the supply of affordable housing without government subsidies (MRSCW 1995, 9);
  - (3) Benefiting older homeowners, single parents, young home buyers, and the disabled (Hare 1989, Report I, 3);
  - (4) Integrating affordable housing more uniformly in the community (MRSCW 1995, 9);
  - (5) Providing homeowners with extra income to help meet rising home ownership costs (MRSCW 1995, 12);
  - (6) Providing a means for adult children to give care and support to a parent in a semi-independent living arrangement (MRSCW 1995, 12);
  - (7) Reducing the incidence of housing deterioration and community blight by preventing absentee ownership of properties (Verrips 1983, 70);
  - (8) ADUs in owner occupied single-family homes foster better housing maintenance and neighborhood stability (MRSCW 1995, 12; ERA 1987, 30);
  - (9) Residential neighborhoods can accommodate a meaningful number of ADUs without significant negative impacts because these areas were typically designed for households with more persons than are occupying these areas (Verrips 1983, iv);

- (10) ADUs provide the opportunity for increased security and companionship for older and other homeowners who fear crime and personal accidents (MRSCW 1995, 13; Cal. Stats. 1982, ch. 1440 Section 1);
- (11) ADUs help meet growth management goals by creating more housing opportunities within existing urban areas (MRSCW 1995, 12);
- (12) ADUs enhance job opportunities for individuals by providing housing nearer to employment centers and public transportation; and ADUs can enhance the local property tax base (Goldman and Hodges 1983, 7).

B. Purposes and Intent.

It is the policy of the State to promote and encourage the creation of ADUs in a manner that enhances residential neighborhoods in order for the people of the State to meet their housing needs and to realize the benefits of ADUs.

C. Definitions.

*Note: We have defined both accessory apartments and cottages to guide communities in adopting ADU ordinances and because this model state act (Section 5.C.) requires municipalities to give the state statistics that distinguish between accessory apartments and accessory cottages. If a state is adopting a statute that does not require this distinction and record keeping, the state may use “second unit,” as in the California statutes. We prefer the wording of “accessory” over “second” relative to these units in this model statute because the word “second” may unnecessarily have negative connotations for adjacent single-family homeowners.*

- i. “Accessory” means that the ADU serves single-family dwelling purposes, rather than meaning that an ADU must necessarily be subordinate to or smaller than the principal dwelling unit on a single-family lot.

*Note: The traditional legal meaning for “accessory” is that an accessory use of any type must be subordinate to a principal use. Because of this traditional meaning, we have defined “accessory” relative to ADUs to ensure that, if a community so desires, the ADU may be larger than the principal unit and the owner may live in either unit. In other words, this definition helps avoid a court ruling that the “accessory” dwelling unit must be smaller than the principal unit and must be occupied by a tenant rather than the owner of the principal unit. Letting the owner live in either unit is important because a major benefit of ADUs is income for homeowners, allowing them to maintain their homes or to “age in place.” Some homeowners prefer to live in the smaller unit, usually the ADU, in order to maximize their income from the rent-producing unit. In addition, this definition supports Section 10 of the model local ordinance, which permits the owner-resident to live in either the principal dwelling unit or the ADU.*

- ii. “Accessory cottage” means a type of ADU that is a house built or placed permanently on the same lot as a single-family house. An accessory cottage may be attached or detached from the house but is not built within the existing house.
- iii. “Accessory apartment” is a type of ADU that is created by converting part of, or adding on to an existing detached single-family home or row house, or by building a separate unit into a new single-family home.
- iv. “Accessory dwelling unit” (ADU) is the general term for accessory apartments and cottages. It means a residential living unit that provides complete independent living facilities for one or more persons. It shall include permanent provisions for living, sleeping, eating, cooking, and sanitation on the same parcel as the single-family dwelling it accompanies (adapted from Cal. Gov’t Code Section 65852.2(I)(4)).
- v. “Default provisions” means the standards of Section 4 of this Act that a community must apply if it has no local ADU ordinance.
- vi. “Dwelling unit” means a residential living unit that provides complete independent living facilities for one or more persons. It shall include permanent provisions for living, sleeping, eating, cooking, and sanitation.
- vii. “Living area,” means the interior habitable area of a dwelling unit, including basements and attics, but does not include a garage or any accessory structure (Cal. Gov’t Code Section 65852.2(I)(1)).

*Note: This definition is used in a default-provision standard of this model state act (Section 4.F.v.) that limits the floor area of an ADU to not more than 40 percent of the living area of the existing residence.*

- viii. “Municipality” means a general-purpose local government created by general law or a charter, including a city, county, or village.

*Note: In some states, this definition should include towns, townships, and boroughs.*

- ix. “Owner-occupant” means an owner who has legal residency on the premises of a dwelling unit that contains an ADU, who resides in the home at least six months of the year, and whose portion of the dwelling is not occupied when the owner is not present.

## 2. General Regulatory Authority.

Municipalities may, by adopting a municipal ordinance, exercise the authorities granted in this Section of the Act.

*Note: The major issue in this section is whether local governments will be mandated to adopt an ADU ordinance. As discussed in the introduction, this model state act does not mandate adoption of an ordinance by a municipality. However, section A below is recommended because it, along with the remainder of the act, strongly encourages communities to adopt ADU regulations.*

A. Ordinance Adoption.

Any municipality may, by ordinance certified by the State pursuant to this Act, provide for the creation of ADUs in single-family and multi-family residential zones (see similar provisions in Cal. Gov't Code Section 65852.2(a) and Haw. Rev. Stat. Section 46-4(c)).

B. Criteria for Determining Areas.

Municipalities may designate areas within the jurisdiction where accessory units may be permitted. The designation of areas may be based on criteria that may include, but are not limited to, the adequacy of water and sewer services and the impact of ADUs on traffic flow (adapted from Cal. Gov't Code Section 65852.2(a)(1)).

*Note: At times, communities exclude ADUs from various neighborhoods without a reason related to the physical community, such as adequacy of certain services. Section 2.B. of the model state act guides local governments to consider these service factors as a basis for determining the appropriate areas for ADUs.*

C. Approval Process.

Municipalities may establish a process for the issuance of a permit or a conditional use permit for ADUs (adapted from Cal. Gov't Code Section 65852.2(a)(4)).

*Note: Section C deals with whether a community must allow ADUs by right, simply by making application, or must go through a conditional use permit process that often involves a hearing. Adopting a conditional permit process typically gives communities more control over ADUs than if the units are allowed by right. For more discussion of the issues related to the approval process, see the note in Section 4 of the model local ordinance.*

D. Imposing Standards.

Municipalities may impose standards on ADUs that include, but are not limited to, parking, height, setback, lot coverage, architectural review, and maximum size of unit (adapted from Cal. Gov't Code Section 65852.2(a)(2)).

*Note: This section clarifies that a municipality, in approving an application to create a legal ADU, may impose conditions related to the factors discussed above.*

E. Requiring Owner Occupancy.

Based on the finding of this act, that premises with owner-occupants are better maintained, the legislature declares that a municipal regulation requiring properties with ADUs to be owner occupied, either in the accessory unit or the principal unit, prevents deterioration of neighborhoods and is a regulation substantially related to land-use impact. Such a requirement is, therefore, a regulation of land use rather than a regulation of the user of land.

*Note: Courts may rule that a community has no zoning authority to require that a site with an ADU be occupied by the owner, on the basis that this regulates the land user rather than the land use (Ziegler 1995, 56A-8). However, on July 29, 1996, a California appeals court issued the only published court decision (issued by a court higher than a trial court) addressing the owner-occupancy requirement in the context of ADUs. In the case of Sounhein v. City of San Dimas, 55 Cal. Rptr. 2d 290, the court heard a claim by homeowners that the city's owner-occupancy requirement imposed on their ADU permit was invalid; even if it were not invalid, it applied only to the "applicant" and not subsequent owners. But the court upheld the owner occupancy requirement as a "character of the property as owner-occupied" and further ruled that the requirement applies to all subsequent owners of the premises. *Id.* at 296. Such a condition attaches to the land, the court explained, in order to fulfill the legislative purposes in imposing the condition. *Id.* The purposes of the owner-occupancy requirement, the court noted, are to discourage speculation in residential properties that can make housing less affordable, to prevent the disadvantages of absentee ownership, and to preserve residential neighborhood character. The Sounhein case means that the owner-occupancy requirement for ADUs has now been directly addressed and upheld by a state court.*

*In Section 2.E., the state legislature gives municipalities the specific authority to require owner occupancy on the basis that it encourages maintenance of the dwellings and premises.*

F. Less Restrictive Provisions.

This Act does not limit the authority of municipalities to adopt less restrictive requirements for the creation of ADUs (adapted from Cal. Gov't Code Section 65852.2(e)).

*Note: This section clarifies that the model state act generally does not cut back on a community's power to adopt provisions that are less restrictive than those in the model state act. For example, Section 3.D. of the model state act limits how many parking spaces may be required for each ADU. However, section 2.F. allows a community to be less restrictive if it so desires. For example, it may not require any parking spaces to be provided for a new ADU. Emphasizing that local ordinances may be less restrictive than the model state act allows communities to be less restrictive on ADUs if they witness their benefits and become more comfortable with the idea of ADUs in single-family zoning districts.*

G. Maximum or Minimum Size.

A municipality may establish minimum and maximum unit size requirements for both attached and detached ADUs (adapted from Cal. Gov't Code Section 65852.2(d)).

*Note: The size of ADUs can raise the concerns of neighbors that the units are either too large or too small (see the model local ordinance, Section 17, for more on these issues). This section of the model state act makes it clear that a community adopting its own ADU ordinance may set limits on how large or small an ADU can be. Communities not adopting their own ordinances cannot set maximum or minimum size on attached or detached ADUs. (Maximum size limits are set by the default provisions.) In other words, for communities that want to set their own standards on ADU sizes, this section gives them incentives to adopt their own ordinances.*

#### H. Use, Density, and Plan Consistency Rules.

Municipalities may provide that ADUs do not exceed the allowable density for the lot upon which the ADU is located, and that ADUs are a residential use that is consistent with the existing community plan and zoning designation for the lot (adapted from Cal. Gov't Code Section 65852.2(a)(3)).

*Note: An issue for ADUs is whether they are inconsistent with existing residential zoning, zoning density standards, and community plans. Section 2.H. authorizes communities to accommodate ADUs by stating — in the appropriate local documents (ordinances, or plans) — that the units are harmonious with local plan policies and density concerns. This is a perfectly reasonable assumption, since family size is shrinking in the U.S. and much of the space in homes and infrastructure in residential neighborhoods was originally designed for larger families and is now underused.*

### 3. Limiting Regulatory Authority.

#### A. Noninterference by Other Law.

No municipality may develop, amend, or interpret other codes or regulations, such as building codes or special taxing district provisions, in ways that interfere with the intent of this Act.

*Note: At times, neighbors' fears and misperceptions about ADUs can put political pressure on local elected officials to use their powers to veto homeowners' plans to develop ADUs. A wide variety of local government actions and regulations can be used for this purpose. While it is likely that only a small percentage of municipalities would misuse their powers against ADUs, this section makes it illegal for them to do so.*

#### B. Exemption from Growth-Limitation Measures.

ADUs shall not be considered in the application of any local ordinance, policy, or program to limit residential growth (adapted from Cal. Gov't Code Section 65852.2(a)(5)).

*Note: If this provision is not included in a statute, a community could adopt an ordinance allowing the creation of ADUs only to have the units banned because of existing growth limit measures, such as moratoria or quotas on*

*building permits. These latter growth control measures should not apply to ADUs because they can be accommodated within the present infrastructure capacities of existing residential neighborhoods.*

C. Prohibiting ADUs.

No municipality shall adopt an ordinance that totally prohibits ADUs within single-family or multi-family zoned areas unless the same:

- i. Contains findings acknowledging that it may limit housing opportunities of the region;
- ii. Contains findings that the ban is justified because of specific adverse impacts on the public health, safety, and welfare that would result from allowing ADUs within single-family and multi-family zoned areas;
- iii. Bases the latter findings on technical reports of studies of the municipality;
- iv. Explains why such units cannot be accommodated within the present utility and service capacities of existing single-family neighborhoods; and
- v. Is certified by the State Housing Office as conforming to this Act, in the same procedure defined in Section 5. Until certification of any such ordinance, applications for approval shall be subject to the default provisions of this Act. (adapted from Cal. Gov't Code Section 65852.2(c)).

*Note: Because the general policy of the statute is to encourage the development of ADUs, this section requires communities to justify any ban on them. Few communities in California banned these units following adoption of its ADU law in 1982 (CDHCD 1987, VIII-13). However, this section is stronger than the California law and makes it more difficult for a community to ban ADUs. Although, under California law, a ban on ADUs must be accompanied by specific findings, it does not have to be based on a technical report of a study of the community, as is required by this section. In addition, unlike the California law, this section requires that the state Office of Housing must certify an ordinance banning ADUs.*

D. Parking Requirements.

Parking requirements for ADUs shall not exceed one parking space per unit or per bedroom, whichever is greater. Additional parking may be required, provided that a finding is made that the additional parking requirements are directly related to the use of the ADU and are consistent with existing neighborhood standards applicable to existing dwellings. Off-street parking shall be permitted in required residential yards, setback areas, or through tandem parking (adapted from Cal. Gov't Code Section 65852.2(e)).

*Note: This section prevents communities from requiring more parking than is reasonable, and it applies to communities with and without ADU ordinances (see Section 20 of the model local ordinance for more discussion on parking).*



E. Fees.

Fees for permitting construction of ADUs shall not exceed 30 percent of the fees that would be charged for creation of a single-family home in areas with similar zoning.

*Note: This provision addresses the fact that high fees can be major disincentives to homeowners seeking to develop ADUs (see the note in Section 5 of the model local ordinance).*

4. Default Provisions.

A municipality without an adopted state-certified ADU ordinance that receives an application for a permit for an ADU on or after [the effective date of the Act] shall accept the application and approve or disapprove the application pursuant to the default provisions of this Section 4 of the Act, unless it adopts a certified ordinance in accordance with this Act within [120] days after receiving the application.

*Note: This provision tells municipalities how to process their first application to create an ADU if they do not have an ordinance that conforms to this model state act. It also gives communities the option of quickly adopting their own ordinance and getting state certification if the community prefers its own provisions rather than the model state act's default provisions. This will encourage communities to adopt their own ADU rules.*

A. Only Basis for Denial.

No other local ordinance, policy, or regulation shall be the basis for the denial of a building permit or a use permit under Section 4 of the Act (Cal. Gov't Code Section 65852.2(b)(2)).

*Note: This provision prevents a community without an ADU ordinance from excluding an ADU on the basis of any other measure. While this section says that no other rules shall be applied (except those that apply to other residences), the next section prevents a local government from applying the default provision's standards in a stricter fashion.*

B. Maximum Without Local Ordinance.

The default provisions of this Section 4 establish the maximum standards that municipalities shall use to evaluate proposed ADUs on lots zoned for residential use that contain an existing single-family dwelling. No additional standards, other than those provided in this section, shall be used or imposed, except that a municipality may require lots or parcels of land with an ADU to be owner occupied (adapted from Cal. Gov't Code Section 65852.2(b)(2)).

C. No Changes Necessary.

No changes in zoning ordinances or other ordinances or any changes in the general plan shall be required to implement the default provisions of this Act. Any municipality may amend its zoning ordinance or general plan to incorporate the policies, procedures, or other provisions applicable to the creation of ADUs if these provisions are consistent with the limitations of the default provisions (adapted from Cal. Gov't Code Section 65852.2(b)(4)).

*Note: A community is subject to the default provisions of this model state act if it does not have an ADU ordinance of its own. But if a community without an ADU ordinance wants to amend a comprehensive plan or other ordinance, this provision allows it to do so if the amendment is consistent with the default provisions.*

D. Accommodating Units.

An ADU that conforms to the requirements of the default provisions shall not be considered to exceed the allowable density for the lot upon which it is located and shall be deemed a residential use consistent with the existing general plan and zoning designations for the lot. ADUs shall not be considered in the application of any local ordinance, policy, or program to limit residential growth (adapted from Cal. Gov't Code Section 65852.2(b)(5)).

*Note: This provision is designed to protect ADUs from other local laws. If a community adopts its own ordinance, it may require more land area for an ADU. But if the community has no ADU ordinance and is therefore subject to the default provisions of this model state act, it cannot require an ADU to be on a lot larger than the minimum lot size for the zoning district. This is another example of how a community may gain more control over ADUs by adopting its own ADU regulations.*

E. Public Notice of Public Official.

On the first Monday of each yearly quarter, each municipality of the state that has not adopted state-certified ADU regulations shall publish in the general newspaper of greatest frequency and circulation the name, title, address, and hours of availability of the public official who is responsible for processing applications for permission to develop ADUs under the default provisions of this Act.

F. Standards.

Every municipality shall grant a permit or special use or a conditional use permit for the creation of an ADU if the unit complies with all provisions of this Section 4, including the following standards (adapted from Cal. Gov't Code Section 65852.2(b)(1)):

- i. The proposed ADU is not intended for sale and may be rented (adapted from Cal. Gov't Code Section 65852.2(b)(1)(A));

*Note: The issue that this standard addresses is whether the homeowner can sell only the ADU to another person while still owning the principal home and lot. By preventing the sale of the ADU, this standard is designed to prevent the creation of dual ownership of two buildings on, or from, one single-family lot (see the discussion of this issue in Section 18 of the model local ordinance).*

- ii. The lot proposed to contain the ADU is zoned for single-family or multi-family use (adapted from Cal. Gov't Code Section 65852.2(b)(1)(B));

*Note: This standard addresses the issue of whether ADUs will be built in commercial and industrial land zoning districts. Essentially, this standard, by allowing ADUs only on land zoned for residential uses, prevents occupants of ADUs from suffering the impacts of commercial and industrial land uses.*

- iii. The lot proposed for an ADU contains an existing single-family dwelling (adapted from Cal. Gov't Code Section 65852.2(b)(1)(C));

*Note: In dealing with ADUs, communities must decide if they will be allowed in new units or only in existing ones. This standard clarifies that under the default provisions, ADUs cannot be built simultaneously with, or before, a new dwelling unit (see also the discussion of similar issues in the model local ordinance, Sections 7, 13, and 14).*

- iv. The ADU is either attached to the existing dwelling and located within the living area of the existing dwelling or detached from the existing dwelling and located on the same lot as the existing dwelling (adapted from Cal. Gov't Code Section 65852.2(b)(1)(D));

*Note: This section allows unattached ADUs. Many communities do not want such ADUs in their residential neighborhoods (see the discussion in the model local ordinance, Section 3, Authorization for ADUs by Zoning District). For that reason, this provision may encourage some local governments to push for adoption of a local ADU ordinance that leaves out this provision.*

- v. The floor area of an attached ADU shall not exceed 40 percent of the living area of the existing residence (adapted from Cal. Gov't Code Section 65852.2(b)(1)(E));

*Note: In the California default provisions, the increase in floor area was limited to 30 percent. For the issues related to this provision, see the model local ordinance, Section 17.*

- vi. The total area of floor space for a detached ADU shall not exceed 1,200 square feet (Cal. Gov't Code Section 65852.2(b)(1)(F));

*Note: See the discussion of maximum ADU size in the model local ordinance, Section 17.*

- vii. Requirements relating to height, setback, lot coverage, architectural review, site plan review, fees, charges, and other zoning requirements generally applicable to residential construction in the zone in which the property is located are applicable to any ADU (Cal. Gov't Code Section 65852.2 (b)(1)(G));

*Note: This section allows a local government to apply other residential construction rules to ADUs. Politics as well as practicality justifies this section — that is, exempting ADUs from standards applied to residential construction could create opposition from neighbors and local elected officials. Although the model state act limits the laws that can be applied to ADUs, this section clarifies that residential construction standards do apply to ADUs.*

- viii. Local building code requirements that apply to detached dwellings, as appropriate, are to be applied to an ADU; and
- ix. Approval by the local health officer where a private sewage disposal system is being used, if required (Cal. Gov't Code Section 65852.2(b)(1)(I)).

*Note: For a discussion of the public health issues related to this provision, see the model local ordinance, Section 21.*

## 5. State's Role in ADU Policies.

### A. Required Municipal Ordinance Submission.

A municipality shall submit a copy of the ordinances adopted pursuant to Section 2 or Section 3.C. to the Office of Housing within 60 days after adoption (adapted from Cal. Gov't Code Section 65852.2(h)).

*Note: This section is optional for states that do not want to give themselves a strong role related to ADUs. In this section, communities are required to submit their ADU ordinances to the state whether they are regulating (Section 2) or banning ADUs (Section 3.C.).*

*In addition to submitting ordinances after they are adopted, municipalities are required (under Section 5.B.) to present proposed ADU ordinances prior to adoption for the state's review. Submitting the ADU ordinance is the initial step that allows the state to play its role in the remaining sections of this model state act.*

### B. State Certification of ADU Ordinances.

A municipality shall submit the zoning ordinance, amendments to a certified ordinance, or an ordinance banning ADUs 30 days prior to final approval of such ordinance or amendment to the State Office of Housing for an opinion on whether the ordinance conforms to this statute. This submission must include the municipality's date of planned final approval. The Office of Housing may notify other relevant agencies so that they may also comment on whether or not the municipality's draft ordinance conforms to the statute. The Office of Housing shall notify the municipality prior to its planned date of final approval of its opinion as to conformity of the ordinance to this statute. If, in the opinion of the Office of Housing, the ordinance and/or amendments reviewed do not conform to this statute, the Office of Housing shall notify the local jurisdiction of actions that must be taken to bring the ordinance(s) and/or amendments into conformity.

The jurisdiction must bring its ordinance into conformity, as recommended by the Office of Housing pursuant to the prior section, within 90 days of notification of nonconformance by the Office. If the municipality has not brought its ordinance into conformity within the 90-day period, the Office of Housing will notify the jurisdiction that it must automatically accept and process applications for ADUs under the default regulations of this Act until conformity is certified by the Office of Housing. Prior to any certification by the Office of Housing, any applications submitted under the default regulations of this Act shall be processed fully and solely under those regulations.

Amendments to a municipality's ordinance certified by the Office must be submitted and certified in the same manner and procedure as the initial proposed ordinance pursuant to this section.

C. Municipal Annual Reports to State.

Each municipality shall report annually to the Office of Housing the following statistics, on a form to be provided by the Office of Housing, the number of:

- i. Single-family structures in the jurisdiction;
- ii. Single-family structures in single-family residential zones and in multi-family residential zones in which accessory units are permitted;
- iii. Illegal accessory apartments or accessory cottages, attached and unattached, known or estimated to be in the jurisdiction;
- iv. Applications to legalize illegal accessory apartments submitted to the jurisdiction and the results of processing these applications;
- v. Legal accessory apartments and accessory cottages, attached and unattached, in the jurisdiction;
- vi. Applications for new accessory units accepted for processing;
- vii. Applications approved and/or permits issued by size, number of bedrooms, and area location;
- viii. Applications disapproved, with reasons categorized by requirements not met; and
- ix. Complaints against legal ADUs, with the complaints categorized by the perceived impacts, such as parking, aesthetics, or traffic.

D. State Annual Report.

The Office of Housing shall prepare an annual report to the Governor and the legislature from the annual reports from the municipalities, including the installation rates of ADUs and recommendations, if any, for amending the Act or other implementation measures necessary for developing ADUs as affordable housing. The annual report shall include any recommendations from the State Advisory Board on ADU policies.

E. State Advisory Board on ADU Policies.

i. Creation.

The Office of Housing shall establish an Advisory Board to monitor implementation of

the Act and to recommend amendments to the Act or model local ordinance provisions to the Office of Housing.

ii. Composition.

The Advisory Board shall be appointed by the Director of the Office of Housing in consultation with the legislature and Governor and shall include one representative from each of the following groups: remodelers, mortgage bankers, real estate agents, new home builders, first-time home buyers, home health care agencies, local permitting agencies, and organizations for the disabled, older persons, and neighborhoods.

iii. Duties.

The Advisory Board's duties shall include, but not be limited to, preparing an annual commentary on the report prepared by the Office of Housing on accessory units. The Board's commentary shall contain recommendations for furthering the purposes of the legislation and will be published and circulated with the Office of Housing's annual report.

*Note: This section of the model state act is optional. It gives the state the role of encouraging ADUs and reviewing local efforts to accommodate them. This role includes action by a state agency — the Office of Housing. The model state act recommends that state Offices of Housing certify local ordinances as conforming to the statute, analyze data from annual municipal reports (Section 5.C.), and provide recommendations to the legislature and Governor for promoting ADUs.*

*One shortcoming of Washington State's ADU statute was that it did not provide a way for the state to assess how the statute was working at the local level (Hope 1996). This shortcoming is typical of existing ADU legislation. The optional monitoring provision here would require communities to report specific ADU data to the State Housing Office (Section 5.C., which applies to all communities within a state) and to obtain ADU policy recommendations from a State Advisory Board (Section 5.E.). With the benefit of the community data and the advisory board recommendations, the Office of Housing would prepare an annual report proposing new or amended policies to the state legislature and Governor (Section 5.D.). This optional monitoring mechanism would assist the state in assessing the law's success. Because it allows well-informed policy adjustment to be made, it should help ensure the ultimate success of the state ADU policies. The authors, however, recognize that some states would be unwilling or unable to afford such a monitoring program. Omission of these provisions, giving the state this monitoring role, would not be fatal to the purposes of the model state act.*

## MODEL LOCAL ORDINANCE ON ACCESSORY DWELLING UNITS

### I. General Provisions.

#### 1. Purpose and Intent.

*Note: In this section of the ordinance, a community makes clear what it is trying to achieve in adopting the ordinance. This information may help in defending the ordinance in a court case or in informing citizens as to how the ordinance will benefit and protect their interests. In spite of the advantages this section can provide, communities have typically omitted it in their ADU ordinances.*

*If a community has no purposes that are different from those of the model state act, it may simply want to reference that act's findings (Section 1) and its purposes and intent (Section 2). We highly recommend that a community adopting an ADU ordinance copy the information in Section 1 of the model state act and present these findings (particularly the benefits of ADUs) to citizens at public hearings. In addition, the local legislative body would be wise to adopt, if this is not part of its ordinance, Section 1 of the model state act, including the benefits, into the record of its minutes when it adopts the ADU ordinance. Afterward, the public official administering the ADU ordinance can make this information available to persons inquiring about ADU permits.*

*If a community has public purposes that are different from those in the model state act, those purposes should be specified in the ordinance (after consulting legal counsel that they are not inconsistent with the purpose of state ADU legislation). For example, some communities use ADUs to help rehabilitate rundown areas containing large older houses; others intend for only certain groups to benefit from ADUs, such as the disabled, older persons, or family members. The model local ADU ordinance presents options (optimal, favorable, or minimal) to meet varying conditions and concerns in different communities. (See Introduction to Model State Act on Accessory Dwelling Units and the Model Local Ordinance on Accessory Dwelling Units.) We have provided a minimal option that targets only certain populations as beneficiaries of ADUs. (See the note accompanying Section 11 below related to limiting the occupants of ADUs.)*

**[Optimal provision]** It is the policy of [name of local government] to promote and encourage the creation of legal ADUs in a manner that enhances residential neighborhoods and helps residents meet their housing needs and realize the benefits of ADUs.

**[Favorable provision]** None

*[Minimal provision]* It is the policy of [name of local government] to promote and encourage the creation of legal ADUs in a manner that enhances residential neighborhoods in order that persons [name target groups, such as older persons] can meet their housing needs and realize the benefits of ADUs.

## 2. Definitions.

*Note: Terms in an ordinance that should be defined are those that the public may not be familiar with and those that vary from the ordinary definitions in Webster's dictionary. Since the model local ordinance must be consistent with the model state act, the latter's definitions of accessory, accessory dwelling unit, accessory apartment, accessory cottage, living area, and owner-occupant should be included in this model local ordinance. A community may simply incorporate these definitions by reference to the model state act, as we have done here to save space. However, users of an ordinance (e.g., applicants for a permit) are inconvenienced by such a practice since most do not have easy access to state laws. Therefore, it is better to repeat the model state act's definitions in the ordinance. In addition to the definitions in the model state act, the ordinance adds a definition for Zoning Administrator. Note that, because the ADU ordinance is part of a local zoning ordinance, the definitions of the zoning ordinance will apply to the ADU ordinance.*

“Zoning Administrator” means the local official who is responsible for processing and approving or denying applications to develop or legalize ADUs.

*Note: As discussed in Section 4 below, this model local ordinance assumes that the community Zoning Administrator has the authority to act on applications for ADUs. However, if the approval process, as discussed in Section 4 below, is the one used for a conditional use permit, the planning commission, a board of zoning adjustment, or another local body may be responsible for acting on ADU applications.*

## II. Permits: Eligibility and Application.

### 3. Authorization for ADUs by Zoning District.

*Note: This section addresses allowing ADUs in specific types of zoning districts (or zones). Neighbors' fears about harmful impacts of ADUs result in some communities banning ADUs or only allowing them in one zone, while other communities are more liberal. In a 1995 survey of 150 communities in the Province of British Columbia, for example, 46 allowed ADUs only in two-family zones, 41 allowed them in single- and two-family zones, 10 allowed them only in single-family zones, and 42 prohibited ADUs (BCMHRSC 1995, 5).*



*The model state act allows communities to designate areas where ADUs are permitted and sets out the types of criteria for determining those areas (See sections 2A and 2B). In addition, the Act allows communities to locate ADUs in any single-family or multi-family zones.*

*These statutory provisions give communities wide discretion in permitting ADUs in many types of residential zoning districts. But in using this discretion, communities must make some key decisions about the capacities of various types of residential zones to absorb ADUs. Certainly, not all types of residential zones are equal in this regard. The desirability of locating ADUs in the major types of residential zones is discussed below.*

*Multi-family zones. These zones are distinguished by multi-family structures that not only have common walls between dwelling units but also are atop one another. The typical principal units are apartments or condominiums in multi-story structures. ADUs are seldom, if ever, allowed in these zones because they tend to have less potential than do single-family zones for accommodating ADUs in terms of available parking, infrastructure, and unused housing space.*

*Clustered single-family zones. These zones contain single-family dwelling units that have common walls but are not atop one another. These zones may be called low-density, multi-family zones or higher density, single-family zones, and they have as principal units row houses, townhouses, or clustered single-family dwelling units. Siting ADUs in these zones is also difficult for several reasons. Parking is often inadequate in areas with townhouses, row houses, or clustered single-family units. In addition, building and fire codes often require bedrooms to have a window for exterior emergency exits by occupants. For this reason, common walls shared by dwelling units greatly reduce the potential to locate accessory apartments in zones with these types of principal units.*

*Single-family zones. These zones contain one single-family dwelling unit per lot and provide the greatest opportunities for siting all types of ADUs. Even in these zones, however, neighbors' concerns about property values and aesthetics often cause communities to ban detached accessory cottages or to allow them only on larger lots. Detached units are more expensive to build (MRSCW 1995, 34) and are usually a relatively small portion of the total number of ADUs in a community. One of the reasons that accessory apartments outnumber detached units is because illegal detached ADUs are impossible to hide. In towns with a preponderance of small lots (such as Daly City, California), not allowing detached ADUs is appropriate (MRSCW 1995, 34). Attached cottages are allowed in more communities than are detached cottages.*

*None of the three model provisions allow ADUs in multi-family zones as described above. The optimal provision allows all types of ADUs in single-family zones with one principal unit per lot, but only accessory apartments in zones with single-family units sharing common walls. In the latter zones, apartments are allowed only if the applicant provides proof that the ADU conforms to fire and building code requirements. The favorable provision does not permit ADUs in zones with dwelling units that have walls in common, but in other single-family zones (districts with one dwelling unit per lot), accessory apartments and attached cottages may be built.*

*The favorable provision also allows detached accessory cottages in the one-unit-per-lot zones if a specified minimum lot size is met. (This authority is not extended in the favorable provision to other types of residential zones, even if that minimum lot size happens to be met by an individual applicant, because the parking problems in those zones would not strike a balance between the neighbors' concerns and those of ADU developers.) In the minimal provision, accessory apartments are authorized only in zones with one home per lot, and accessory cottages are not allowed in any zones.*

*In adapting the model provisions to a local zoning ordinance, a community will substitute its zoning district names (or abbreviations) for the model provisions' descriptions of zoning districts. For example, a community labeling its one-unit-per-lot zone as "Single-Family Residential Zone (SFR)" will substitute that for "zoning districts designed primarily to permit single-family homes on individual lots" in these model provisions. Similarly, "Townhouse Residential Zone (TR)" may be substituted for "zoning districts designed primarily for single-family homes with walls attached to other single family homes."*

**[Optimal provision]** ADUs are allowed in zoning districts designed primarily to permit single-family dwelling units on individual lots. Accessory apartments may be located in zoning districts designed primarily for single-family dwelling units with walls attached to other single family homes when applicants provide written evidence from the proper fire and building officials that the proposed ADU conforms to building and fire code regulations.

**[Favorable provision]** An accessory apartment or an attached accessory cottage may be permitted in any residential zone designed primarily to permit single-family dwelling units on individual lots. A detached accessory cottage may be located in this same zone on a lot with a minimum lot size of [specify minimum size].

**[Minimal provision]** An accessory apartment may be allowed in zoning districts designed primarily to permit single-family dwelling units on individual lots.

#### 4. Approval Process.

*Note: A lengthy and burdensome application process will discourage homeowners from developing ADUs (Gellen 1985, 185; MRSCW 1995, 28). An application procedure that involves a public hearing means a loss of privacy (Gellen 1985, 185) and added time to reach a final decision on the permit (Hare 1989, 20). One study noted that application periods ranged from one day to six months (CSS 1991, 22). Advocates of ADUs argue that requiring a conditional use permit for an ADU is unfair when ADUs typically have less impact than single-family residences that are allowed by right. Neighbors, on the other hand, may prefer the conditional use permit process so they can collectively voice their concerns before local decision makers.*

*The two basic options available to a community are to allow ADUs through the conditional use permit (sometimes called special exception, special permit, or special land use) or to allow them by right in the zoning district. "By right" means that the process involves filling out an application and presenting it to a local building official or Zoning Administrator, who will check to see that it meets the requirements of the ordinance. No hearing or discretionary decision is involved. The conditional use permit process, however, involves a hearing preceded by public notice. The "by right" approach has the advantage of being fast and less public for ADU applicants. Of course, if there is a great deal of political resistance to adopting an ADU ordinance, the reassurance that ADUs will be subject to the conditional use process, with hearings, can persuade law makers to adopt an ordinance. Communities that are new to the process may choose the latter approach.*

*This model local ordinance is written with a Zoning Administrator making the decision to issue an ADU permit. If a community wants to use a conditional use approach, the provisions of this ordinance are easily convertible by substituting, in the place of the Zoning Administrator, the name of the local body that makes decisions on conditional use permits. The type of local body varies but is often a planning commission, a zoning commission, or a zoning board of appeals.*

*The favorable provision below is designed to speed up permit processing. A hearing will not be necessary in every case. A neighbor can choose to meet with an applicant and the building official to review the application. However, if a neighbor has serious concerns, a hearing can be conducted after the neighbor requests one in writing. Several sources have recommended this provision, which can eliminate the need for a public hearing (Hare 1989, 21; CSS 1991, 55). Another option would be to notify at least 10 adjacent property owners to check for possible objections. If none were raised, the application would not be processed via the conditional use permit procedure (CSS 1991, 55).*

*The optimal provision allows ADUs by right without a hearing, and the minimal provision is to make ADU applicants go through the conditional use permit process with a hearing. The full procedure for a conditional use process is not given in this section because the local zoning ordinance (of which the ADU is a part) will provide those procedures, which are often specified in the state zoning enabling act.*

*In choosing a procedure for ADUs, it is important to keep in mind that even ADUs allowed by right are subject to standards in the ordinance. The trend in Washington State communities that have recently adopted ADU ordinances is to allow them by right, subject to ordinance criteria (MRSCW 1995, 27).*

**[Optimal provision]** One ADU is permitted per residentially zoned lot, provided the Zoning Administrator first approves the proposed ADU as complying with the standards of this ordinance.

**[Favorable provision]** One ADU is permitted per residentially zoned lot, provided the Zoning Administrator first approves the proposed ADU as complying with the standards of this ordinance, unless a property owner requests in writing that the application be processed via a conditional use permit procedure. Within five days after receiving a completed application for approval of an ADU, the Zoning Administrator shall notify by mail all property owners within 300 feet of the property proposed for an ADU. The notice to the property owners shall inform the owners that they may, at any time within 30 days of the date of mailing of the notice, in writing to the Zoning Administrator either demand and have a meeting with the applicant and the Zoning Administrator to review the application, or can cause the application to be processed with conditional use permit procedures. Within the same 30-day period, the Zoning Administrator shall meet simultaneously with an applicant and owners who have properly demanded meetings to review the application. If either the applicant or the Zoning Administrator fails to meet with such an owner, the owner may demand in writing to the Zoning Administrator that the application be processed via the conditional use permit procedure.

**[Minimal provision]** One ADU is permitted per residentially zoned lot by conditional use permit if the proposed ADU conforms to the standards of this ordinance.

## 5. Application Fees and Information.

*Note: Other difficulties for homeowners contemplating installing an ADU are permit fees, complicated applications, and multiple-stop approval processes. Application fees associated with a hearing can also be much higher than are application fees unrelated to hearings. A 1989 study of 47 communities found that in the 10 communities with the greatest installation rates for ADUs, none had fees higher than \$2,000 (Hare 1989, 15). The same study revealed that in the County of Los Angeles, an applicant paid a \$3,000 fee that was nonrefundable for an ADU, and the permit was denied (Hare 1989, 21).*

*The model state act (Section 3.E.) does not allow the fees for ADUs to be higher than 30 percent of the application fee for a single-family residence. This section levels the playing field for ADUs. The optimal provision is consistent with the model state act, limiting the ADU fees to 30 percent of the fees for a house, but the favorable provision does not conform to the act because it allows communities to charge equal fees for ADUs and other dwelling units.*

**[Optimal provision]** Application fees for ADUs shall not be more than 30 percent of the application fees for a single-family dwelling unit. The information required on applications for creating or legalizing ADUs shall be the same information that is required to construct a single-family dwelling unit.

**[Favorable provision]** Application fees and application information required for ADUs shall be less than or equal to those required to construct a single-family dwelling unit.

**[Minimal provision]** None

#### 6. Permit Renewal (Monitoring).

*Note: In order to make sure that an ADU continues to comply with the conditions that were a part of the permit as originally issued, some communities issue temporary permits and require periodic permit renewal. For example, in a survey of 50 communities with ADU ordinances, 14 percent issued temporary permits (APA 1996). While requiring permit renewal and inspections has the advantage of making neighbors feel more comfortable with ADUs, it increases administrative costs related to an ordinance. More significantly, this requirement discourages the creation of ADUs for reasons similar to those of limiting groups of eligible occupants, as discussed in the introduction to the model state act ("Avoiding Policies that Deter New ADUs"). Bankers and the homeowners who actually have a financial stake are more nervous about temporary permits.*

*For this reason, we have written optimal and favorable provisions to provide permanent permits. The optimal provision requires the ADU owner to file an annual statement that the ADU complies with the local ordinance. The favorable provision states that the permit expires if the ADU no longer conforms to the ordinance and that a complaint by a neighbor can cause a hearing to determine conformance to the ordinance. But the permit issued for an ADU under the minimal provision is only a temporary one and must be renewed. This provision is waived, however, if there are no complaints of violations made to the Zoning Administrator. Communities that want to apply a more strict provision can remove that portion of the provision that allows the ADU owner to have the permit renewal waived if no complaints are filed.*

**[Optimal provision]** The owner of an ADU shall, on the first day of every year [or specify intervals in number of years], sign and file written statements with the Zoning Administrator that the ADU complies with the municipal zoning code.

**[Favorable provision]** A certificate of occupancy [or permit] issued for an ADU shall expire if the ADU does not conform to the municipal zoning code. If a complaint is made to the Zoning Administrator by a landowner within 300 feet of the ADU, the Zoning Administrator shall cause a hearing to be held within 60 days after the date of the complaint to determine if the ADU violates the municipal zoning code. Fifteen days prior to the public hearing, the Zoning Administrator shall notify all property owners within 300 feet of the site of the ADU of the hearing. Revocation of a permit by the Zoning Administrator must be based on an inspection of the ADU premises and a written record of the Zoning Administrator's findings at the hearing.

**[Minimal provision]** Permits for ADUs shall be issued for a period not longer than five years and must be renewed at the end of the first term of issuance and every such period thereafter. Temporary permits for ADUs do not have to be renewed if, during the time period since the date of the last renewal or waived renewal date, no complaints of violations of the municipal zoning code by the ADU are filed with the Zoning Administrator. Renewal of temporary permits requires inspection of the ADU premises by the Zoning Administrator.

### III. Standards.

#### 7. Lot Standards - Occupied by Dwelling Unit.

*Note: Can a permit be issued for developing an ADU on a lot that is not already occupied by a dwelling unit? This section addresses whether an ADU can be designed and built simultaneously with the construction of a new residence. This question springs from a community's general reluctance to convert a single-family zone into a duplex zone. Many local ordinances, such as the default provisions of the model state act (Section 4.F. iii.), allow ADUs only on lots that already have dwellings. This is common (APA 1996). Some local governments, however, have begun to allow new houses to be constructed with ADUs (MRSCW 1995, 47). Communities adopting their own ordinance under the model state act can allow ADUs in, or with, new residences. Proponents of ADUs have emphasized that ADUs built in new houses are less expensive "with designs that more effectively address exterior appearance and parking issues" (MRSCW 1995, 47).*

*For the latter reason, our optimal provision allows ADUs to be designed and built in or related to new dwellings. The optimal option allows all types of ADUs to be developed related to new homes.*

*Accessory apartments, rather than either attached or detached accessory cottages, are generally more acceptable as a type of ADU built in relation to*

*new residences. Consequently, in the favorable provision only accessory apartments are allowed to be built related to new homes. The minimal provision requires lots to have an existing dwelling in order to be eligible for an ADU permit.*

*If a community does allow ADUs in new houses, as per Section 7, it would be contradictory to base eligibility for an ADU on the age of the principal dwelling or how long it has been owned. (See Sections 13 and 14 concerning standards for principal dwelling units.)*

**[Optimal provision]** An ADU may be incorporated in either an existing or a new dwelling unit (W OCD 1994, Section A.7.).

**[Favorable provision]** An accessory apartment may be incorporated in either an existing or a new dwelling unit.

**[Minimal provision]** The lot proposed for an ADU shall contain an existing single-family dwelling unit (adapted from Cal. Gov't Code Section 65852.2(b)(1)(C)).

#### 8. Lot Standards - Minimum Size.

*Note: This section addresses the lot sizes required for ADU installation. This requirement is often excessive and can greatly diminish the number of ADUs in a community. In a survey of 50 ordinances, the minimum lot size requirement varied from 4,500 square feet to one acre (APA 1996). One community allows detached ADUs only on lots that are 1.5 times the minimum lot size of the zoning district (Orange County, Fla., Zoning Code Sec. 38-1426 (f)(4)). Some communities have the same minimum lot-size requirements for all ADUs. When the requirements are not the same, greater lot sizes are required for detached units than for accessory apartments. The model state act (Section 2.H.) allows communities to exempt ADUs from lot density requirements.*

*The provisions below require the minimum lot size of the underlying zoning district for all types of ADUs, with two exceptions. First, the optimal provision allows ADU apartments to be on lots that are a specified number of square feet — presumably smaller than the zoning district's minimum lot size. One proponent of ADUs argues that minimum lot sizes may disqualify older homeowners, and others with homes on small lots, from installing ADUs and receiving their benefits (MRSCW 1995, 45). For this reason, the optimal provision below requires that the minimum lot size be met only for accessory cottages, while lots that are a specified size may contain dwellings with accessory apartments.*

*Second, in the minimal provision, communities must specify the minimum number of square feet of lot size that is eligible for detached ADUs. Some*

*communities may want this minimum lot size to be more than the minimum lot area required in the zoning district because neighbors are sometimes concerned about overcrowding and the impact of detached ADUs on property values and aesthetics.*

*Other approaches to dealing with the density of ADUs per land area are mentioned in the note to Section 22 below.*

**[Optimal provision]** ADUs may be developed on lots meeting the minimum lot size for the respective zoning district, except that accessory apartments may be on lots that are [specify number of square feet].

**[Favorable provision]** ADUs may be developed on lots meeting the minimum lot size for the respective zoning district.

**[Minimal provision]** ADUs may be developed on lots meeting the minimum lot size for the respective zoning district, except that detached accessory cottages may be developed only if the lot size is [specify number of square feet] or more.

#### 9. Lot Standards - Setback and Lot Coverage.

*Note: ADUs are generally subject to setback and coverage requirements of zoning ordinances. For this reason, this model ADU ordinance, similar to the Washington model (W OCD 1994), does not separately address this issue. These issues are highly related to aesthetic concerns covered in sections below.*

#### 10. Occupancy Standards - Owner of Premises.

*Note: Some neighbors are concerned that allowing ADUs will cause deterioration of neighborhood properties because landlord speculators will buy up houses with ADUs and rent out both units (MRSCW 1995, 28). The fear is that tenants will not maintain the units. A popular way to allay these fears is to require the owner of the lot to reside on the premises — the majority of ADU ordinances contain this requirement (APA 1996). There is evidence that owner occupancy does lead to better maintenance of the premises (Verrips 1983, 70). Not surprisingly, neighbors tend to want the adjacent premises with ADUs to be owner occupied (Town of Babylon, New York 1979, 2). In order for owner occupancy to be most effective in fulfilling the purposes of ADUs, it is important to allow the owner to live in either unit (see the discussion in Section 1.C i. of the model state act, the definition of “Accessory”). Communities often allow homeowners to reside in either the principal unit or the ADU (APA 1996).*

*The optimal option includes both aspects of owner occupancy — requiring owner occupancy and allowing it in either unit — because both tend to*



*facilitate the development of new ADUs. For communities that may not feel comfortable allowing the owner to live in either unit, the minimal provision requires the owner to reside in the principal dwelling unit. No favorable provision is recommended.*

*Many communities monitor ADUs to ensure that the owner still lives on the premises. A variety of methods are used to do this monitoring (see Section 6), including registration of occupants, certification of occupancy, and annual licensing of rental units with annual inspections.*

*Other communities require ADU owners to record the requirements of the ADU ordinance as deed restrictions, particularly the owner-occupancy requirement. The deed restrictions accompany the title of the property and give notice to all subsequent buyers of the occupancy requirement. Both the optimal and favorable provisions below require this registration.*

*Various provisions of the model also address the issue of owner occupancy. Those provisions allow and support the requirement that the owner live in the larger or smaller unit (see the discussion in Section 2.E. of the model state act; also see Section 1.A.v. (7) — findings about benefits of owner occupancy — and the definitions of “Accessory” and “Owner-Occupant”). If a community adopts this ordinance but does not have a statute echoing these provisions of the model state act, it may want, with the advice of counsel, to include versions of those provisions in its zoning ordinance.*

**[Optimal provision]** A lot or parcel of land containing an ADU shall be occupied by the owner of the premises, and the owner may live in either the ADU or the principal dwelling unit. Within 30 days of securing approval for construction of an ADU, the owner shall record against the deed to the subject property, a deed restriction running in favor of the municipality limiting occupancy of either the principal dwelling unit or the ADU to the owner of the property. Proof that such a restriction has been recorded shall be provided to the Zoning Administrator prior to issuance of the occupancy permit for the ADU (adapted from WOCDC 1994, Application Procedures).

**[Favorable provision]** None

**[Minimal provision]** A principal dwelling unit on a lot or parcel of land containing an ADU shall be occupied by the owner of the premises. Within 30 days of securing approval for construction of an ADU, the owner shall record against the deed to the subject property, a deed restriction running in favor of the municipality limiting occupancy of either the principal dwelling unit or the ADU to the owner of the property. Proof that such a restriction has been recorded shall be provided to the Zoning Administrator prior to issuance of the occupancy permit for the ADU (adapted from WOCDC 1994, Application Procedures).

## 11. Occupancy Standards for ADUs.

*Note: Limiting eligible occupants of ADUs can keep the number of installations of ADUs down. In a 1996 survey of 50 ADU regulations, 18 percent of the communities limited occupancy of ADUs to persons who were elderly, disabled, or related to the owner (APA 1996). Requiring the occupant to be a relative of homeowner is the most frequent limitation.*

*Although these policies can have good intentions (e.g., to provide care for the special needs of the owner or occupant), the limitations can discourage investors in ADUs and can cause enforcement problems for communities. In fact, the trend in ADU regulations is away from these types of regulations (MRSCW 1995, 35). A more reasonable and legally defensible approach to occupancy limitations may be requiring a minimum number of square feet of living area of the ADU per person. But in our view, the optimal option is not to have an occupancy standard.*

*Some communities, however, may insist on this type of limitation; we have provided a favorable provision that, like one county ordinance, limits occupancy only during the ADU's first three years (Orange County, Fla., Zoning Code Section 38-1426 C (2) a). The community may define the number of persons and characteristics of persons who are eligible occupants (e.g., relatives, older persons, or disabled persons). The three-year limit may serve to encourage investments in ADUs since the owner will be certain of a greater pool of potential occupants after that time.*

*Finally, we have provided a minimal option that allows the locality to limit the occupancy of an ADU to a specified group. While we do not recommend adoption of such a provision, its inclusion may be the only way to obtain passage of an ordinance. In these cases, it should be viewed as a transitional phase allowing the locality to gain experience with ADUs and leading to further liberalization of the ordinance.*

*Prior to adopting a provision limiting the occupancy of ADUs, a community should obtain a legal opinion as to whether such a restriction violates the federal Fair Housing Act (42 U.S.C.A. Sec. 3601). Among the groups protected from housing discrimination by this federal law are families with children under 18 years of age.*

*As previously mentioned, the favorable and minimal options limit the number of occupants. In a recent survey of ADU ordinances, the limitations on the number of persons ranged from two to five, with some communities requiring occupancy by families (APA 1996). The most common limitation on the number of persons occupying an ADU was less than three.*

**[Optimal provision]** None

**[Favorable provision]** During the first three years after the issuance of a permit for an ADU, the occupants of the ADU shall be limited to [specify] in number and persons who are [specify eligibility criteria].

**[Minimal provision]** The occupants of the ADU shall be limited to [specify] in number and persons who are [specify eligibility criteria].

## 12. Principal Dwelling Unit Building Standards - Minimum Floor Area.

*Note: Some communities do not want smaller houses to have a related ADU because the ADU may be dominant and inconsistent with the single-family character of a neighborhood. Communities sometimes set a minimum size for the principal dwelling unit as an eligibility requirement for constructing an ADU. While a recent survey of 50 ordinances did not reveal any communities that took this approach (APA 1996), the survey did find that communities often regulate the relative sizes of the ADU and the principal unit by setting maximums on ADUs in terms of percentage of the living space of the principal dwelling or a maximum floor area size for the ADU, or both. Setting a minimum size on principal units as an eligibility requirement for an ADU is not recommended; it is better to deal with the issue of consistency with single-family character by limiting the size of the ADU in terms of a percentage of the principal dwelling unit (See Section 17 below.)*

## 13. Principal Dwelling Unit Building Standards - Age.

*Note: This section addresses the question of how soon an ADU can be installed after the principal dwelling is constructed. The discussion assumes that the ADU being built is an accessory apartment. Accessory cottages built with new houses would create the greatest amount of political resistance (more than accessory apartments), raising concerns about the single-family zone being converted to a duplex zone.*

*Regulations that require houses to be a certain age before becoming eligible for an ADU are adopted out of homeowners' concern that too many ADUs will overwhelm the neighborhood. The specific concern is that houses will be designed and marketed with ADUs if new houses can have them. ADUs should not be allowed in new houses, opponents say, because the intent behind them is to use the existing housing stock (MRSCW 1995, 47). To address this issue, communities sometimes set limits on how quickly ADUs can be built, based on the age of the principal dwelling units. (Even more rarely, communities use ADUs to revitalize only older neighborhoods and require the principal dwelling to be built before a certain date, such as 1976. (See Hamden, Conn., Zoning Regulations (1996) and Hare 1981, 14).*

*An age limitation on the principal dwelling unit will reduce the number of ADUs developed, and the optimal provision allows buildings of any age to be eligible for an ADU. The favorable provision would not permit ADUs in buildings completed in the last three years. As a minimal provision, the principal dwelling unit is eligible for an ADU after it is a specified number of years old. The age required for the principal dwelling unit is generally from two to five years (APA 1996). If a community does allow ADUs in new houses, as in Section 7, it would, of course, be contradictory to base eligibility for an ADU on the age of the principal dwelling or how long it has been owned, as in some provisions in Sections 13 and 14.*

**[Optimal provision]** An ADU may be developed in either an existing or a new dwelling unit (WOCD 1994, Sec. A.7.).

**[Favorable provision]** An ADU may be developed in a dwelling unit that has been completed for at least three years.

**[Minimal provision]** An ADU may be developed in a dwelling unit that has been completed for at least [specify] years.

#### 14. Principal Dwelling Unit Building Standards - Term of Ownership.

*Note: Requirements concerning the term of ownership are similar to those regarding the age of the principal dwelling. They deal with the question of how long the principal dwelling must be owned by the current owner before an ADU can be constructed. Neighbors can raise the concern that speculators will buy houses simply to install an ADU. Advocates for ADUs point out that term of ownership requirements bar first-time buyers from using ADU rental income to defray house mortgage or maintenance costs (MRSCW 1995, 48). Also, requiring that the principal dwelling or the ADU be owner occupied is an effective protection against speculation. As with restrictions on the age of the principal dwelling, we do not recommend term-of-ownership requirements. Requiring home ownership for a specified number of years is the minimal provision.*

**[Optimal provision]** An ADU may be developed in either an existing or a new dwelling unit (WOCD 1994, Sec. A.7.).

**[Favorable provision]** None

**[Minimal provision]** An ADU may be developed in a dwelling unit that has been owned at least [specify] years by its current owner.

## 15. ADU Building Standards - Architectural Design and Types of Structures.

*Note: This section and the remaining sections on building standards govern the appearance of accessory cottages. Homeowners adjacent to ADUs are sometimes concerned that ADUs will erode the single-family charm of their neighborhood, and ADU ordinances commonly address many appearance issues (APA 1996), such as type of structure, architectural design, maximum size, minimum size, and whether the ADU is subordinate to the principal unit.*

*This section specifically deals with the type of structure (mobile home, site-built dwelling, or manufactured housing) that can be used as an ADU. It also addresses whether the ADU must be architecturally consistent with the principal unit and whether it must be consistent in appearance with a site-built single-family residence. The optimal provision maximizes the opportunities for ADUs by allowing any type of structure to be an ADU if that structure is allowed as a principal unit in the zoning district. No other appearance requirements are placed on ADUs in the optimal provision. The favorable provision is more restrictive by allowing manufactured houses to be ADUs only if they are allowed in the zone and are consistent with the appearance of a single-family residence. The minimal provision adds to the favorable provision the requirement that the ADU must be consistent with the building type of the principal dwelling unit.*

**[Optimal provision]** A mobile home or manufactured dwelling unit may be used as an ADU in any zone in which dwelling units are permitted (adapted from WOCDC 1994, Section 9).

**[Favorable provision]** A manufactured dwelling unit may be used as an ADU in any zone where that type of structure is permitted if the appearance of the same remains that of a site-built, single-family dwelling unit (WOCDC 1994, Section 9).

**[Minimal provision]** A manufactured dwelling unit may be used as an ADU in any zone where that type of structure is permitted if the proposed ADU is consistent with the building type of the principal unit and the appearance of the ADU remains that of a site-built, single-family dwelling unit (WOCDC 1994, Section 9).

## 16. ADU Building Standards - Orientation of Entrance.

*Note: Many ADU regulations focus on the entrance of the ADU as an aesthetic concern. Most communities discourage or prohibit entrances from being constructed on the front of principal buildings. Thus, entrances and particularly stairways are limited to side or rear yards. When a front entrance is required for physical or cost reasons, communities often demand that the front entrance to the principal dwelling must double as the entrance to both units. The options below vary in how strictly entrances and stairways are regulated. The optimal provision requires ADU entrances to be less visible than principal dwelling unit entrances, and stairways may not be on the front*

*of the principal dwelling unit. The favorable and minimal provisions are similar, in that both require ADU entrances not to be visible from the street view and limit ADU stairways to the rear of principal dwelling units. While the favorable provision allows ADUs to share a front entryway with the principal dwelling unit, the minimal provision does not.*

**[Optimal provision]** If the ADU's primary entrance is not the same as that for the principal dwelling unit, it shall be less visible from the street view of the principal dwelling than the main entrance of the principal dwelling unit (adapted from WOCDC 1994, Section A.10.), and the ADU's stairways may not be constructed on the front of the principal dwelling unit.

**[Favorable provision]** The ADU's primary entrance shall be not visible from the street view of the principal dwelling, and the ADU's stairways may not be constructed on the front or side of a principal dwelling unit.

**[Minimal provision]** No entrance for an ADU shall be permitted on, or, from the front of a principal dwelling unit; the ADU's primary entrance shall be not be visible from the street view of the principal dwelling unit; and the ADU's stairways may not be constructed on the front or side of a principal dwelling unit.

#### 17. ADU Building Standards - Size.

*Note: This section deals with a number of issues related to the size of the ADU. The intentions of communities in setting size limitations are commonly to require the ADU to be subordinate to the principal dwelling unit, to control neighborhood density, and to control visual impacts.*

*The standards of this section set minimums on the ADU square footage and maximums on the total square footage and number of bedrooms of the ADU. A common minimum size requirement for an ADU is 300 square feet; a frequent maximum on number of bedrooms is two; and the maximum size for ADUs falls in the range of 600 to 1,200 square feet, with 800 square feet occurring most often as a maximum size (APA 1996).*

*This model local ordinance does not directly require the ADU to be subordinate to the principal unit but does so indirectly by setting the maximum floor space of the ADU as a percentage of the living area of the principal unit. Advocates for ADUs point out that less affluent homeowners in smaller houses may not qualify to build an ADU if their house is too small (MRSCW 1995, 30). For example, if the ADU may not be larger than 30 percent of the living area of the principal unit but may not be smaller than 300 square feet, a homeowner with a living area of only 900 square feet could not have an ADU (270 square feet is 30 percent of 900 square feet and less than the minimum required size of 300 square feet). For this reason, the favorable and minimal provisions below raise the maximum percentage to 40 percent of the living space of the principal unit. Such a maximum percentage*

*is not unusual (APA 1996). Communities wanting to be more strict than the minimal option can change the percentage after determining that greater limitations are needed to protect the public interest. The maximum size of an ADU in the optimal provision is 1,200 square feet and 800 square feet in the minimal provision. (The maximum ADU size allowed in a recent survey of 50 ADU ordinances was 1,200 square feet [APA 1996].)*

*No alternative is listed as the optimal option. Size can be limited by other regulations. The Uniform Building Code (Sections 1207 and 1208), for example, contains a minimum size for efficiency units. Similarly, lot coverage maximums and minimum lot sizes limit the size of accessory cottages. Health codes can also limit the number of bedrooms in an ADU.*

**[Optimal provision]** None

**[Favorable provision]** In no case shall an ADU be more than 40 percent of the living area of a principal dwelling unit, nor more than 1,200 square feet, nor less than 300 square feet, nor have more than two bedrooms (adapted from WOCD 1994, Section A.8.).

**[Minimal provision]** In no case shall an ADU be more than 40 percent of the living area of a principal dwelling unit, nor more than 800 square feet, nor less than 300 square feet, nor have more than two bedrooms (adapted from WOCD 1994, Section A.8.).

#### 18. ADU Building Standards - Not Intended for Sale.

*Note: An argument of opponents to ADUs is that the owners will eventually sell them off as condominiums. While this can create double owner occupancy of the premises, it can also result in the premises being occupied only by tenants. Thus, the opponents are concerned that the premises will not be as well maintained as owner-occupied premises. Opponents also warn that turning some ADUs into condominiums makes their fear of a neighborhood of duplexes a reality. The California ADU statute has a “not intended for sale” standard (Cal. Gov’t Code Section 65852.2(b)(1)(A)), and communities occasionally impose similar requirements (APA 1996).*

*One concern, however, is that if a community voids an ADU permit because the ADU has been sold for a condominium, a court may reverse the community action on the basis that zoning can regulate land use but not types of land ownership (Ziegler 1995, 56A-11 and 56A-12). Before adopting this standard, legal counsel should be consulted because courts are also reluctant to uphold regulations that may limit property owners’ ability to sell their land. Since this standard basically addresses the concerns of neighbors, it is listed below as a minimal option.*

**[Optimal provision]** None

**[Favorable provision]** None

**[Minimal provision]** The ADU shall not be intended for sale and may be rented (adapted from Cal. Gov't Code Section 65852.2(b)(1)(A)).

#### 19. ADU Building Standards - Screening and Orientation.

*Note: Privacy is at the heart of neighbors' fears about being overrun by ADUs. This standard protects neighbors' privacy by giving the permit issuer a number of factors to consider, and the ADU homeowner a variety of options, that can be used to honor any adjacent landowner's privacy. While it could be argued that this standard balances the neighbors' and the ADU owners' interests, many owners are likely to view it as inconvenient or even onerous. Such a standard is relatively rare and is listed as a minimal option because it focuses more on the neighbors' concern over the visual or privacy impacts of ADUs.*

**[Optimal provision]** None

**[Favorable provision]** None

**[Minimal provision]** The orientation of the proposed ADU shall, to the maximum extent practical, maintain the privacy of residents in adjoining dwellings as determined by the physical characteristics surrounding the ADU, including landscape screening, fencing, and window and door placement (adapted from City of Olympia, Washington, Unified Development Code, Section 18.04.060 1.b. 1995).

#### 20. Parking and Traffic.

*Note: Because of the average drop in household size, traffic is not generally a problem with ADUs. Most neighborhoods that house ADUs were designed for families that would generate more traffic than today's actual occupancy levels (Verrips 1983, iv; Gellen 1985, 151-152). For this reason, we recommend no standards for controlling traffic. Communities that are concerned about traffic may want to deal with it under density controls, as discussed in Section 22 below.*

*The issue of parking, however, is more complicated. Parking standards are one of the most frequent concerns (Hope 1996), and one expert views parking as the most difficult issue (Hare 1989, 24). Not surprisingly, communities tend to require too many parking spaces, making parking requirements one of the major obstacles to increasing the number of new ADUs (CHCD 1989, VIII-13). For example, in a 1996 survey of local ADU ordinances (APA 1996), 4 of the 50 surveyed communities required up to three spaces per ADU. But in*



*suburban communities where hilly terrain does not limit parking on sites or streets, ADUs will not cause parking problems (Verrips 1983, 83).*

*In addition, there is a reluctance in many communities to allow tandem parking (one vehicle in front of the other in a driveway) and to allow parking in setback areas even when that is a normal practice in a neighborhood. Advocates of ADUs emphasize that single-family homes with teenagers can generate as much or more traffic, and the need for parking is often minimal as ADUs are frequently occupied by “empty nesters” and single persons who have fewer cars or no car (MRSCW 1995, 38 and 39).*

*The controversy over parking illustrates that communities vary tremendously in terms of physical conditions and parking norms. These norms vary from cars being invisible to cars being ubiquitous, including tandem parking, parking on sideyard parking pads, and curbside parking (Gellen 1989, 172). Neighbors often vary in how much curbside parking they think can be allowed before they see the neighborhood streets as overcrowded. Because neighborhoods have different standards, a performance approach is needed, allowing flexibility rather than a set rule that ignores the variety of circumstances (Gellen 1989, 172).*

*The optimal provision limits the number of spaces that can be required, while the favorable provision allows a flexible approach because more than one parking space may be required under certain conditions. Both of these options are consistent with the model state act, whereas the minimal provision is not. The minimal option is required by some communities. However, it focuses on neighbors’ concerns and creates difficulties for owners of ADUs because it does not allow parking in setbacks, tandem parking, or on-street parking. In addition, this requirement may be more onerous than parking requirements for the principal dwelling unit. (An assumption related to these standards is that there is only one ADU per principal dwelling unit.)*

**[Optimal provision]** One parking space is required per ADU if:

- a. the same requirement exists for the principal dwelling unit;
- b. no other parking spaces are available in side or rear yards, by tandem parking, or on-street parking; or
- c. the use of the ADU will create the need for an additional parking space.

**[Favorable provision]** One parking space is required per ADU.

- a. Additional parking may be required, provided that:
  1. the Zoning Administrator finds that the additional parking requirements are directly related to the use of the ADU; and
  2. the total number of parking spaces required for an ADU does not exceed the number of spaces required for a principal dwelling unit.

- b. The Zoning Administrator may permit off-street parking in setback areas or through tandem parking if the off-street parking:
  1. would not block access by emergency vehicles to the principal dwelling unit or ADU; and
  2. is permitted and occurs in the neighborhood (adapted from Cal. Gov't Code Section 65852.2(e)).

**[Minimal provision]** Two off-street parking spaces are required for each ADU.

## 21. Public Health.

*Note: The adequacy of water and sewer service to ADUs is generally not an issue because ADUs, rather than creating undue burdens, usually result in more efficient use of these services (MRSCW 1995, 50). Nevertheless, an ADU ordinance standard for water and sewer services should exist if current services are near capacity or ADUs add more bedrooms to the principal dwelling unit. Public health issues are generally addressed through regulations other than zoning, but an ordinance standard can require the homeowner developing the ADU to provide proof of conformance to public health regulations. We consider this standard to be necessary for the benefit of ADU owners and the neighbors. All three options contain this requirement.*

*The minimal option contains an additional requirement. Because of aesthetic concerns, communities sometimes require only one electrical and one water meter per principal dwelling unit. Three communities were found to have this requirement in a recent study of 50 ADU ordinances (APA 1996). Minimizing the meters on the exterior of a building is designed to support the owner-occupancy requirement and to maintain the appearance of single-family rather than two-family houses (MRCSW 1995, 50).*

**[Optimal provision]** Applicants for ADU permits must supply the Zoning Administrator with certification by the municipal health official that the water supply and sewage disposal facilities are adequate for the projected number of residents (adapted from WOCDC 1994, Section A. 2.).

**[Favorable provision]** [Same as optimal provision]

**[Minimal provision]** Applicants for ADU permits must supply the Zoning Administrator with certification by the municipal health official that the water supply and sewage disposal facilities are adequate for the projected number of residents. In addition, only one electrical and one water meter shall be allowed to serve the principal dwelling unit and the ADU (latter sentence adapted from Edmonds, Washington, Community Development Code, Section 20.21.030 C. 1996).

## 22. Density Limits.

*Note: Restrictions on density are designed to reduce the number of ADUs in order to minimize their projected effects on the neighborhood. Density controls may also be put in place to avoid an accumulation of ADUs in the same area or to distribute ADUs evenly through an area (MRSCW 1995, 46).*

*A wide range of methods are used to limit density of ADUs, including:*

- quotas on the total number of ADU permits before an ADU ordinance is repealed;*
- quotas on the number of permits issued before an ADU ordinance is reviewed;*
- periodic reviews of ADU ordinances to evaluate the number of permits issued;*
- limitations on the number of ADUs per area (e.g., by block or census tract);*
- restrictions on the number of ADUs as a percentage of the residences in an area;*  
*and*
- spacing requirements between ADUs.*

*Advocates of ADUs may argue, however, that density rules reduce the number of ADUs unjustifiably. When the infrastructure in single-family neighborhoods is underutilized, why is it fair to say “no” to one homeowner applying to create an ADU simply because another homeowner in the area has already installed an one? Justifying the density control may be even harder if the homeowner with the ADU permit originally installed it illegally and now is issued the permit to legalize wrongdoing.*

*But density controls may be an essential political tool in some communities. Guarantees that neighborhoods will not be overrun by ADUs may increase support for an ADU ordinance in a community. For this reason, density controls are suggested as the minimal provision. Density limits for ADUs are not recommended as optimal options because the controls are hard to justify.*

*The favorable provision calls for annual reporting. This reporting can trigger a reconsideration of the ordinance if density thresholds are exceeded. This option is considered favorable because its effect, rather than vetoing an application for an ADU, is to cause a review of the ordinance for amendments to the ADU ordinance. We want to emphasize that this review calls for “amendments” rather than repeal of the ordinance.*

***[Optimal provision]*** None

***[Favorable provision]*** The Zoning Administrator shall report annually to the municipal legislative body the number of units established, the geographic distribution of the units, the average size of the units, the number and type of complaints, and completed enforcement actions. The municipal legislative body shall reassess this ordinance for amendments every [specify number] years or sooner if records show that 20 percent of the single-family

structures within any census tract or citywide have ADUs (adapted from Tacoma, Wash., Municipal Code, Section 13.06(B)(8) (1996) in MRSCW 1995, 58).

[*Minimal provision* - choose one of the following four options] No applications for ADUs may be accepted in census tracts or areas if granting the permit would cause the percentage of single-family units with ADUs of any single-family zone in one census tract to exceed 20 percent (adapted from Seattle, Washington, Section 23.44.025, Seattle Municipal Code in MRSCW 1995, 46).

[or]

A permit for an ADU may be issued if not more than 10 percent of the existing single-family units within 1,000 feet of the proposed ADU contain existing ADUs (adapted from South Windsor, Connecticut, Section 4.7.1.g., Zoning Ordinance 1990).

[or]

A permit for an ADU may be issued if not more than [specify number] permits have been issued for ADUs over the three-year period since the adoption of these regulations (adapted from Hamden, Connecticut, Section 701 m., Zoning Regulations 1996).

[or]

The Zoning Administrator may issue a permit for an ADU if the total number of permits has not exceeded [specify number]. When this number is exceeded, the Zoning Administrator shall report to the municipal legislative body that the number is exceeded, and that body shall review the ADU ordinance for its continuance, amendment, or repeal.

### 23. Legalizing ADUs.

*Note: An illegal ADU is one that was installed without obtaining the required permits from the local government. Some ADUs may have existed prior to any ordinance making them illegal. Those ADUs can become legal, nonconforming ADUs if they initially conformed to all public laws. However, ADUs installed after zoning regulations were adopted are illegal unless permits were obtained from the local government. After permits are available for ADUs, illegal ADUs may actually be encouraged by harsh regulations, excessive fees, and tedious application procedures. Illegal ADUs are quite common because of the pressure for affordable housing and the reluctance of many communities to legalize ADUs.*

*A goal of some communities that are more familiar with these issues is to legalize the illegal ADUs for safety reasons. But many ADU owners strongly resist legalization out of their fear of higher property taxes, legal sanctions, income taxes on rental income, the costs of conforming to local codes, and the possibility that code inspectors will discover a variety of code violations*

*(Gellen 1985, 187-191). For these reasons, programs to accommodate illegal ADUs have not been very successful (Gellen 1985, 188). In addition, most communities have limited budgets for enforcing ADU regulations, meaning that code enforcement relies on specific complaints. Thus, most communities simply ignore illegal ADUs.*

*A variety of approaches, however, are available to deal with illegal ADUs. First, we recommend not having harsh regulations, lengthy application processes, or high fees that will create even more illegal ADUs. In addition, the model ordinance includes the following approaches: amnesty periods from enforcement, long time periods to comply with regulations, an exemption from all but safety regulations, and the threat of stiff penalties after all else has failed. While there appears to be no optimal or even favorable provision for a community living with numerous illegal ADUs, we do suggest a minimal provision below that includes several of the above options.*

*Some benefits accrue to communities that legalize illegal ADUs. If illegal units are tolerated, the risk is increased that other people will be encouraged to have illegal units. In this instance, it can be quite important for community leaders to make the statement through their ADU regulation that they are committed to the public interest by requiring owners of illegal ADUs to come forward and legalize their units. Furthermore, legalizing the illegal ADUs provides the opportunity to correct dangerous safety hazards (such as inadequate electrical wiring). With these benefits in mind, we suggest the minimal provision for legalizing ADUs below.*

***[Optimal provision]*** None

***[Favorable provision]*** None

***[Minimal provision]*** Any existing illegal ADU will not be subject to any enforcement action if an application to legalize the ADU is submitted within [specify number] months of the adoption of these regulations (adapted from a 1995 draft of Village of Scarsdale, New York, Zoning Code 1995).

[or]

Owners of illegal ADUs shall be guilty of a misdemeanor and subject to a penalty of [specify the maximum allowed by law]. Any existing illegal ADU will not be subject to any enforcement action if:

1. The ADU owner applies for a permit to legalize the illegal ADU permit within [specify] months of the adoption of these regulations;
2. The ADU complies with the minimum requirements of the Uniform Building Code, Section 1208, within [specify] months of the date of applying for a permit under this Section (adapted from Mercer Island, Washington, Section 19.04.0607(D); MRSCW 1995, 45);
3. The ADU complies with the minimum housing code standards within [specify] months of the date of applying for a permit under this Section of the ordinance (adapted from Tacoma, Washington, Section 13.06.196(C)(11) Code, MRSCW 1995, 44); and
4. The ADU owner supplies the Zoning Administrator with certification by the municipal health official that the water supply and sewage disposal facilities are adequate for the ADU (adapted from WOCD 1994, Section A.2.).

## REFERENCES

1. APA (American Planning Association) 1947. *Conversions of Large Single-family Dwellings to Multiple-family Dwellings*, Planning Advisory Service Report No. 461. Chicago: American Planning Association.
2. APA (American Planning Association) 1996. *Accessory Dwelling Unit Survey*. Chicago: American Planning Association.
3. BCMHRCS (Ministry of Housing, Recreation and Consumer Services, Province of British Columbia) 1995. *Secondary Suites, An Affordable Housing Choice for British Columbians: A Summary of Local Government Practices*. Vancouver: Ministry of Housing, Recreation and Consumer Services, Province of British Columbia.
4. Brewitt, Jeff 1987. *Residential Conversions and Parking in Sydenhan Ward* (a report submitted in partial fulfillment of the requirements for the degree of Master of Urban and Regional Planning, School of Urban and Regional Planning, Queen's University at Kingston, Kingston, Ontario).
5. CDHCD (Department of Housing and Community Development, State of California) 1987. *California Affordable Housing Legislation: A Study of Local Implementation, Volume 1*. Sacramento: Department of Housing and Community Development.
6. CDHCD (Department of Housing and Community Development, State of California) 1990. *Second Units*. Sacramento: Department of Housing and Community Development.
7. CSS (Community Systems and Services, Inc.) 1991. *Accessory Dwelling Units: An Evaluation of the Fairfax County Program and Recommendations for Change*. Fairfax County, Virginia: Department of Housing and Community Development.
8. DPDL (Department of Planning and Development, Planning Division, City of London, Province of Ontario) 1995. *Intensification and Bill 120, Impacts on the North London and Broughdale Communities*. City of London, Ontario: Department of Planning and Development, Planning Division.
9. ERA (Ekos Research Associates Inc.) 1987. *The Impact of Conversions on Neighborhoods: Property Values and Perceptions* (a report submitted to Susan Corke, Manager, The Ministry of Housing, Province of Ontario, Toronto, Ontario).
10. Filson, Lawrence E. 1992. *The Legislative Drafter's Desk Reference*. Washington D.C.: Congressional Quarterly, Inc.
11. Gellen, Martin 1985. *Accessory Apartments in Single-Family Housing*. New Brunswick, N.J.: Center for Urban Policy Research, Rutgers, The State University of New Jersey.
12. Goldman, Ellis G. and Hodges, Samuel J. III 1983. *Allowing Accessory Apartments, Key Issues for Local Officials*. Washington, D.C.: Office of Policy Development and Research, U.S. Department of Housing and Urban Development.

13. Hare, Patrick H. 1981. *Accessory Apartments, Using Surplus Space in Single Family Houses*. Planning Advisory Service Report No. 365. Chicago: American Planning Association.
14. Hare, Patrick H., Linda E. Hollis, and David Guttman 1984. *Accessory Apartments: A New Housing Option for the Elderly Homeowner* (a study funded by the AARP Foundation).
15. Hare, Patrick 1989. *Accessory Units: The State of the Art, Report I, Summary of Experience With Accessory Units in the US and Canada*. Washington, D.C.: Patrick H. Hare Planning and Design.
16. Hare, Patrick 1989. *Accessory Units: The State of the Art, Report IV, Survey of Installations of Accessory Units In Communities Where They Are Legal*. Washington D.C.: Patrick H. Hare Planning and Design.
17. HLSB (Legislative Service Bureau, State of Hawaii) 1988. *Ohana Zoning: A Five-Year Review*. Honolulu: Legislative Service Bureau.
18. Hope, Shane 1996. Telephone Interview by APA. Chicago, Ill., 30 August.
19. Knudsen, Corine 1996. Telephone Interview by APA. Chicago, Ill., 30 August.
20. Merriam, Dwight 1983. *Accessory Apartments. Zoning and Planning Law Report 6, No. 5: 121-126*.
21. MRSCW (Municipal Research and Services Center of Washington) 1995. *Accessory Dwelling Units, Issues and Options*. Report No. 33, October 1995. Seattle: Municipal Research and Services Center of Washington.
22. Town of Babylon, New York 1979. *Summary Report of Report on Illegal Two-Family Dwellings in the Town of Babylon*.
23. TSRPC (Tri-State Regional Planning Commission) 1981. *Single-Family Conversions, A Survey of Local Officials in the Tri-State Region*. Interim Technical Report No. 3112. New York: Tri-State Regional Planning Commission.
24. Verrips, Bert 1983. *Second Units: An Emerging Housing Resource*. People for Open Space Housing/Greenbelt Program, Technical Report No. 2-E. San Francisco: People for Open Space.
25. WOCD (Department of Community Development, State of Washington) 1994. *Accessory Dwelling Unit Ordinance Study and Recommendations*. Olympia: Department of Community Development.
26. WFBS& AA (Weir & Foulds, Barristers & Solicitors, and Allan E. Brass Associates, Inc.) 1987. *Portable Living Units for Seniors, Evaluation Part 4: Planning/Regulatory and Legal Assessment*. Toronto: Ministry of Housing.
27. Ziegler, Edward 1995. *Rathkopf's The Law of Zoning and Planning*. Deerfield, Illinois: Clark Boardman Callaghan.



## RESOURCE GUIDE

### *Overviews*

Hare, Patrick H. *Accessory Units: The State of the Art; Report I, Summary of Experience With Accessory Units in the U.S. and Canada*. 1989. (53 pages)

AVAILABLE FROM: Patrick H. Hare Planning and Design, 1246 Monroe St., NE, Washington, DC 20017. 202-269-9334. Price: \$15.

Municipal Research Services Center of Washington. *Accessory Dwelling Units: Issues and Options*. 1995.

AVAILABLE FROM: Municipal Research Services Center of Washington, 1200 5th Ave., Suite 1300, Seattle, WA 98101-1159. 206-625-1300. Price: \$18.

### *“How-To” Guides for Homeowners*

Town of Babylon, New York. *Accessory Apartment Application*.

AVAILABLE FROM: Planning Department, Town of Babylon. 200 East Sunrise Highway, Lindenhurst, NY 11757. 516-957-3102. Free.

Fairfax, Virginia, County Government. *Developing an Accessory Dwelling Unit: A Resource Kit (for homeowners)*. 1991.

AVAILABLE FROM: Jeremy Novak, Program Manager, Home Improvement Loan Program, Department of Housing and Community Development, 3700 Pender Drive, Suite 300, Fairfax, VA 22030. 703-246-5152. Free.

Ontario Ministry of Municipal Affairs and Housing. *How to Create An Accessory Apartment*. 1988. (20 pages)

Ontario Ministry of Municipal Affairs and Housing. *Step-by-Step Guide To Adding A Rental Apartment In Your Home*. 1990. (32 pages)

AVAILABLE FROM: Ministry of Municipal Affairs and Housing, 777 Bay St., 2nd Floor, Toronto, Ontario M5G 2E5. 416-585-7041. Free.

### ***Parking Studies and Approaches***

Brewitt, Jeff. *Residential Conversions and Parking in Sydenham Ward*. Kingston, Ontario: Queen's University at Kingston, School of Urban and Regional Planning. 1987.

(Report: 100 pages)

AVAILABLE FROM: School of Urban and Regional Planning, Queen's University at Kingston, Kingston, Ontario. In case of difficulty in obtaining this document, it may be available on loan from Patrick H. Hare Planning and Design. 202-269-9334.

Marshall Macklin Monaghan Limited, in association with McNair and Marshall. *Parking and Accessory Apartments - A Metro Toronto Case Study*. (66 pages)

AVAILABLE FROM: Ministry of Municipal Affairs and Housing, 777 Bay St., 2nd Floor, Toronto, Ontario M5G 2E5. 416-585-7041. Free.

### ***Neighborhood Impact***

Ontario Ministry of Municipal Affairs and Housing in association with Ekos Research Associates, Inc. *The Impact of Conversions on Neighborhoods: Property Values and Perceptions*. June 15, 1987.

AVAILABLE FROM: Ministry of Municipal Affairs and Housing, 777 Bay St., 2nd Floor, Toronto, Ontario M5G 2E5. 416-585-7041. Free.

### ***Studies of Homeowners and Tenants***

AARP. *Understanding Senior Housing: Into the Next Century*. D13899. Washington, D.C.: AARP, 1996 (Report: 48 pages)

AVAILABLE FROM: AARP Fulfillment, 601 E St., NW, Washington, DC 20049. Free.

### ***Installation Rates***

Hare, Patrick H. *Accessory Units: The State Of The Art; Report IV Survey of Installations of Accessory Units in Communities Where They Are Legal*. 1989. (30 pages)

AVAILABLE FROM: Patrick H. Hare Planning and Design, 1246 Monroe St., NE, Washington, DC 20017. 202-269-9334. Price: \$15.

Starr Group, in association with Richard Drdla Associates and Jerome Markson Architects. *Flexible Use and Tenure Study*. December 1986. (200+ pages)

AVAILABLE FROM: Canada Mortgage and Housing Corporation, 650 Lawrence Avenue West, Toronto, Ontario M6A 1B2. 416-781-2451. Free.

### ***Counseling and Marketing***

Ontario Ministry of Municipal Affairs and Housing. *Neighbours Pilot Project*. June 1991. (48 pages, plus appendices)

AVAILABLE FROM: Ministry of Municipal Affairs and Housing, 777 Bay St., 2nd Floor, Toronto, Ontario M5G 2E5. 416-585-7041. Free.

### ***Politics of Zoning Approval***

Berridge Lewinberg Greenberg Ltd. *Evaluation of Scarborough Intensification Study*. April 1990. (14 pages)

AVAILABLE FROM: Ministry of Municipal Affairs and Housing, 777 Bay St., 2nd Floor, Toronto, Ontario M5G 2E5. 416-585-7041. Free.

Merriam, Dwight H. *Accessory Apartments. Zoning and Planning Law Report 6, No. 5* (May 1983): 123-26.

AVAILABLE FROM: Municipal or university libraries.

### ***Accessory Apartments and Home Buyers***

Clayton Research Associates. *Analysis of Economics of Residential Conversion*. 1987. (28 pages, plus appendices)

AVAILABLE FROM: Ministry of Municipal Affairs and Housing, 777 Bay St., 2nd Floor, Toronto, Ontario M5G 2E5. 416-585-7041. Free.

### ***Accessory Apartments and New Homes***

Bradford, Susan. "Making Room for Granddaddy" *Builder*. January 1991, p. 54

Bradford, Susan. "The New American Home." *Builder*. August 1991, pp. 179-99.

AVAILABLE FROM: Municipal or university libraries.

Howe, Deborah A. "The Flexible House - Designing for Changing Needs." *Journal of the American Planning Association* 56, No. 1 (Winter 1990): 69-77.

AVAILABLE FROM: American Planning Association, Planners Book Service, 122 S. Michigan Avenue, Suite 1600, Chicago, IL 60603. 312-431-9100. Price \$48.

Starr Group, in association with Richard Drdla Associates and Jerome Markson Architects. *New Made-to-Convert Housing*. Ottawa, Ontario: Canada Mortgage and Housing Corporation, 1988. (33 pages)

AVAILABLE FROM: Canadian Housing Information Centre, Canada Mortgage and Housing Corporation. 1-800-668-2642. \$5.95 plus tax and shipping.

### ***Detailed Zoning Studies***

Babcock, Richard F. "The Egregious Invalidity of the Exclusive Single-Family Zone." *Land Use Law and Zoning Digest* 35, No. 7 at 3 (July 1983):

AVAILABLE FROM: Municipal or university libraries.

Hare, Patrick H. *Accessory Units: The State of the Art; Report III Model Zoning*. Washington, D.C.: 1992. (50 pages of model provisions and discussion and 30 pages of sample ordinances from a variety of communities)

AVAILABLE FROM: Patrick H. Hare Planning and Design, 1246 Monroe St., NE, Washington, DC 20017. 202-269-9334. Price: \$45, add \$5 if the order must be invoiced.

Liebmann, George W. "Suburban Zoning - Two Modest Proposals." *Real Property Probate and Trust Journal* 25, no. 1 (Spring 1990).

AVAILABLE FROM: Municipal or university libraries.

### ***Using Accessory Apartments to Increase Density Near Transit***

Archer, Paula and Jill McFarlane. *Accessory Apartments: Characteristics, Issues, Opportunities*. 1990. (48 pages)

AVAILABLE FROM: Canadian Housing Information Centre, Canada Mortgage and Housing Corporation, Building C-200, 700 Montreal Road, Ottawa, Ontario K1A 0P7. 613-748-2367. Free.

Borooah, Ann. *Achieving Housing and Environmental Objectives Through Residential Intensification: A Potential Partnership*. 1992. (21 pages)

AVAILABLE FROM: Ministry of Municipal Affairs and Housing, 777 Bay St., 2nd Floor, Toronto, Ontario M5G 2E5. 416-585-7041. Free.

The prices provided above are correct to our best available information at the time of printing. You will note that most documents available through public agencies are free, while those available from private sources reflect the time and effort in preparing those documents.

Accessory Dwelling Units

Index # - File Name: 1.0007 - Accessory Dwelling Units.pdf



**Public Policy Institute  
601 E Street, NW  
Washington, DC 20049  
[www.aarp.org](http://www.aarp.org)**

**PPI 5703(0300) . D17158**

# Accessory Dwellings

A one-stop source about accessory dwelling units, multigenerational homes, laneway houses, ADUs, granny flats, in-law units...

## Do accessory dwelling units serve older persons? (Or, who lives in, and owns, ADUs?)

[This is part 8 of a 13-part series about ADU research and policy. [Read the series intro and table of contents.](#)]

**You can't really say when ADUs were "invented,"** since having a second small dwelling on a piece of property seems to be an idea as old and natural as the idea of housing itself. Just look at the carriage-house apartments you see in big old houses in Seattle, at farm properties where "new" and "old" structures house different generations or branches of the family, and at family compounds all over Africa and Asia.



If that's too exotic or déclassé for you, look at Thomas Jefferson's Monticello, where, as [Lester Walker](#) has documented in his book about tiny houses, a small, clever house was Jefferson's residence as the big place was being built. This house later became part of one of Monticello's extended wings.



**So ADUs are as old as the hills, and as American as apple pie.**

However, the current era of ADU advocacy started about three decades ago, when there was a lot of concern for how the “elderly,” perhaps better known as older persons, would be housed. Programs like “Double Unit Opportunity” reasoned that a retiring person who built an ADU might then have two kinds of resources:

- a place to live suited to their needs, possibly with family nearby;
- a place to rent out, providing much-needed income;
- or possibly both.

This concept was supported by an opinion poll showing that most aging people wanted to stay in their homes as they aged. AARP supported ADUs with the writing of a model code.

How has that turned out? Is there evidence that ADUs are providing retirement residences and/or financial security for seniors?

**The answer to this one is a little complicated.** To sum up, the statistics *currently* show that ADUs aren’t special when it comes to supporting or housing seniors. However, there are strong suggestions this will change in the future.

It all relates to how ADUs are developed and owned. As you hopefully know, an ADU is, by definition, not a legally separate asset. It is not like a condo or an RV that can be bought or sold on its own. Rather, the person who owns the property and the “main house” also owns the ADU. Because most ADUs in Portland have been created recently, at this point in time the homeowner that created the ADU is usually still the owner. Make sense so far?

Now one of the things early studies of ADUs, such as a “Double Unit Opportunity” (doesn’t that sound like something from a fortune cookie?) discovered was that people of retirement age (65+) were extremely *unlikely* to build ADUs. Instead, it was younger people, usually 35-55, that were willing to



Accessory Dwelling Units

take on the considerable labor and risk of creating a second dwelling. This pattern is evident when I compare the age distribution of Portland ADU owners to the age distribution of Portland homeowners in general:

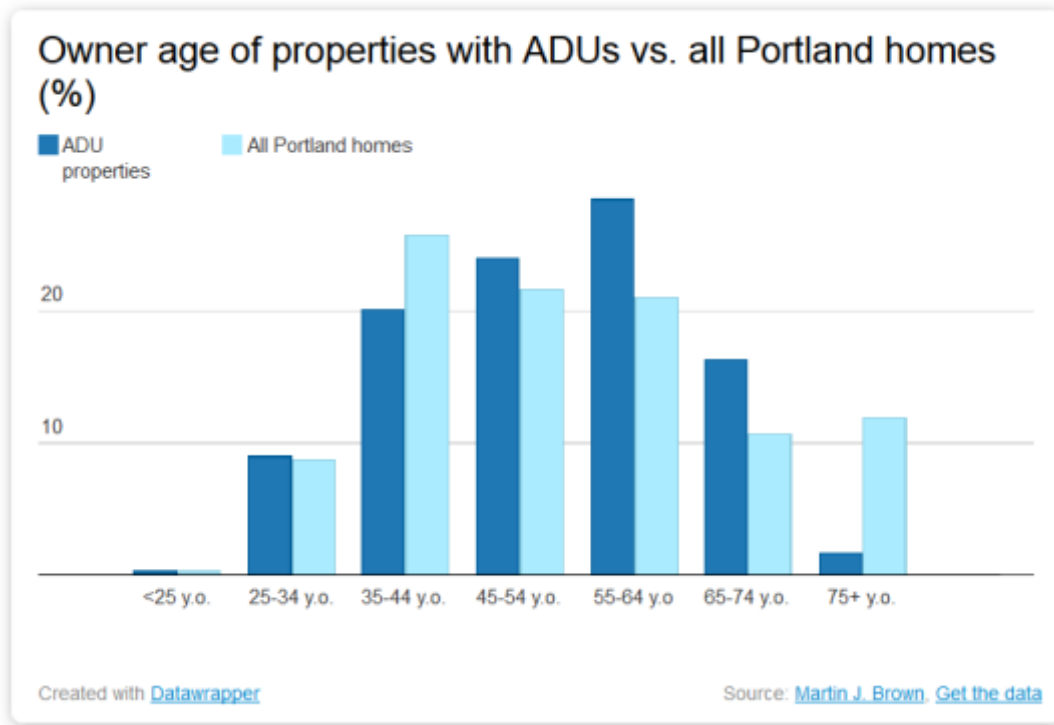

The shapes for the two groups are pretty similar, but there are some curious differences in the highest age classes. ADU owners are equally as likely as the typical Portland homeowner to be 55 or more: 47% of ADU owners are in that age class, vs. 44% for home in general, a difference that is not significant ([see my research paper for statistical details](#)). ADU owners are slightly less likely than the typical Portland homeowner to be 65 or more: 18% of ADU owners are in that age class, vs. 22% of Portland homeowners. Very few ADUs are owned by the most senior seniors, those 75+, as you might expect, because the oldest homeowners don't tend to build ADUs.

However, ADU owners are slightly more likely than general Portland homeowners to be 55-74 years old. **In other words, ADUs are popular among those who are *getting* old, but who aren't in the highest age categories (e.g. 75+) yet.**

Now, who is living in the ADUs these people have created? I made a similar comparison of the ages of ADU tenants to Portland tenants in general.

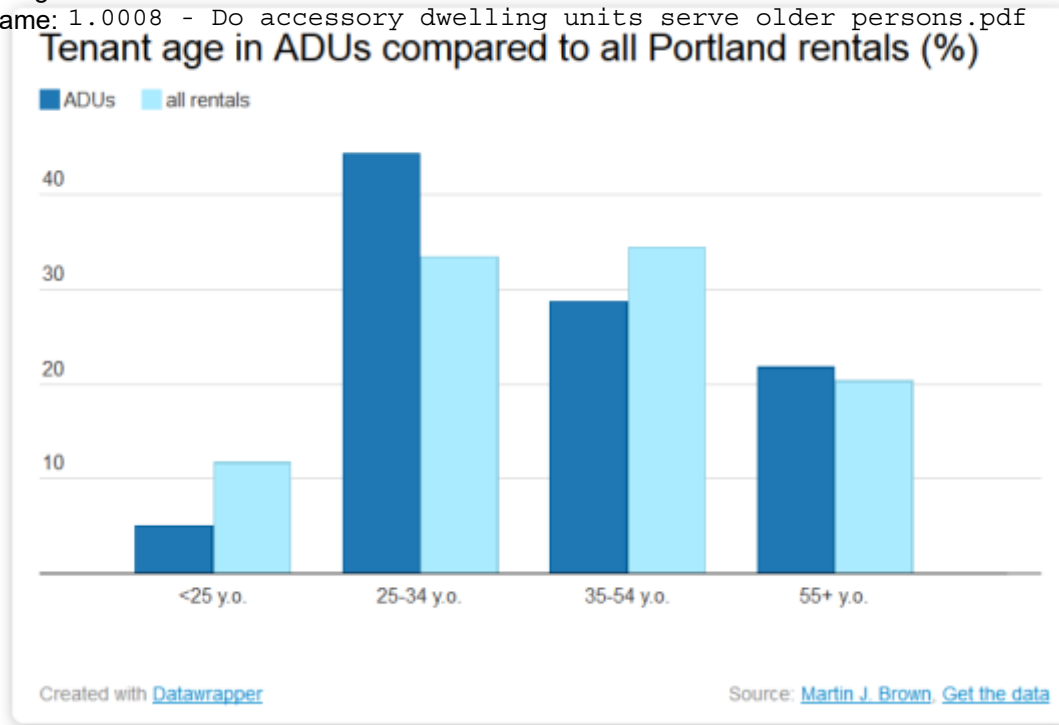

Again, the age distribution of people living in ADUs is generally similar to those in all Portland rentals. The biggest difference is in the 25-34 age group, which is more common in ADUs than in general rentals.

**Looking at these numbers, it's tempting to say that ADUs are just "more of the same,"** housing that has no special qualities for older persons. Currently in Portland, ADUs don't house older persons at greater rates than standard rentals, and they are not owned by older persons at higher rates than other kinds of properties.

**However, this doesn't take into account people's intentions.** Examine the personal commentary of practically anyone who has created an ADU, and you'll see that the homeowner-developers behind ADUs practically always have long-term plans that stretch into retirement. For example, one respondent to the DEQ's survey of Oregon ADU owners wrote,

"We rent [our ADU] to a young family member and might live in the little house when we retire, renting the main house to supplement our income."

For two examples of this idea, on different ends of the cost spectrum, look at [Jane Doe's](#) and [Bruce Nelson's](#) projects.

Moreover, families that have multiple generations living in one place with the help of an ADU generally seem to be really happy with it.

"My favorite feature of my SDU is proximity to my grandkids,"

said Dennis Martin in our profile of his project.

These ideas are so common in personal anecdotes about ADUs (see the dozens of examples in our case studies) that I think the current shape of the ownership and tenant age distributions are an accident of timing. In particular, the shapes of those graphs are the result of two facts: a) it is typically middle-aged people who create ADUs; and b) only in the past 5 or 10 years has creating ADUs been a popular development option in Portland.

**ADUs might not be created very often by retired people, but certainly people who own ADUs will be able to use and own them as they retire.** The comments in our case studies suggest that ADUs are a vital part of family plans for the older persons in their lives, and for their future selves. As a consequence, I think the ADU age-ownership distribution will look quite different ten years from now.

So don't worry, grandma — if there's an ADU in the family, when the time comes it will be there for you.

—

next week: [How do ADUs support the community economically?](#)

## About Martin John Brown



Martin John Brown is a researcher and consultant on environment and housing. Find out more at <http://martinjohnbrown.net>.

[View all posts by Martin John Brown](#) →

## 3 comments on “Do accessory dwelling units serve older persons? (Or, who lives in, and owns, ADUs?)”

Pingback: [Do ADUs cause neighborhood parking problems? | Accessory Dwellings](#)

Pingback: [Research and policy about accessory dwelling units: introducing a 13-part series | Accessory Dwellings](#)

Pingback: [Summing up ADU research: are accessory dwelling units as great, or as horrible, as people say? | Accessory Dwellings](#)

This entry was posted on July 23, 2014 by [Martin John Brown](#) in [Policy & Trends](#) and tagged [elder](#), [elderly](#), [featurepost](#), [housing](#), [older](#), [policy](#), [research](#), [senior citizens](#), [seniors](#).

<https://wp.me/p1R4v3-Wd>

[Previous post](#)

[Next post](#)

[Blog at WordPress.com.](#)

10/15/2019

Do accessory dwelling units serve older persons? (Or, who lives in, and owns, ADUs?) | Accessory Dwellings

Accessory Dwelling Units

Index # - File Name: 1.0008 - Do accessory dwelling units serve older persons.pdf

# Accessory Dwellings

A one-stop source about accessory dwelling units, multigenerational homes, laneway houses, ADUs, granny flats, in-law units...

## Do ADUs cause neighborhood parking problems?

[This is part 7 of a 13-part series on accessory dwelling unit research and policy. [Read the series intro and table of contents.](#)]

When planners and city councilors float the idea of loosening rules about ADUs, one fear comes up more than any other: **ADUs will harm parking conditions**, opponents say. For example:

- [Parking concerns helped nix an ADU proposal in Raleigh, North Carolina](#), according to the *News & Observer*.
- [The Laurelhurst Community Club's letter to Seattle city councilors](#), advocating strong restrictions on ADU development, worries extensively about the effect on parking, and goes beyond requiring dedicated spaces to object to converting garages and "tandem parking."
- ["The \[Austin Neighborhoods Council's\] chief quibble with the proposal is the reduction of parking requirements for the new line of ADUs,"](#) writes the *Austin Chronicle*.

The Austin example is particularly interesting, because the news piece makes it sound like the neighborhood advocates are pretty open to the idea of ADUs, having seen some of the possible benefits. But parking is the sticking point.

Cars are clearly a special, emotional subject. They are, for better or worse, central to the typical American lifestyle. Is use of cars really threatened by ADUs? What is the evidence?

Like practically everything having to do with ADUs, [up until recently there basically was no evidence](#). ADUs were simply too rare for any effect to have been studied. For example, in Portland, Oregon, widely considered to be the leader in ADU development in the US, the number of ADUs was only about 800 in 2013, in comparison to about 148,000 single-family-residence (SFR) properties where ADUs could be allowed.

That rarity, in itself, provides most of the answer. Any effect of ADUs on the total number of cars in an urban area, even one like Portland where ADUs are being developed at a "rapid" pace, is going to be quite small. Here I've used Census statistics and results from the [Oregon DEQ's survey of ADU owners](#) to estimate how many cars ADUs contributed to Portland in 2013, compared to SFR's:

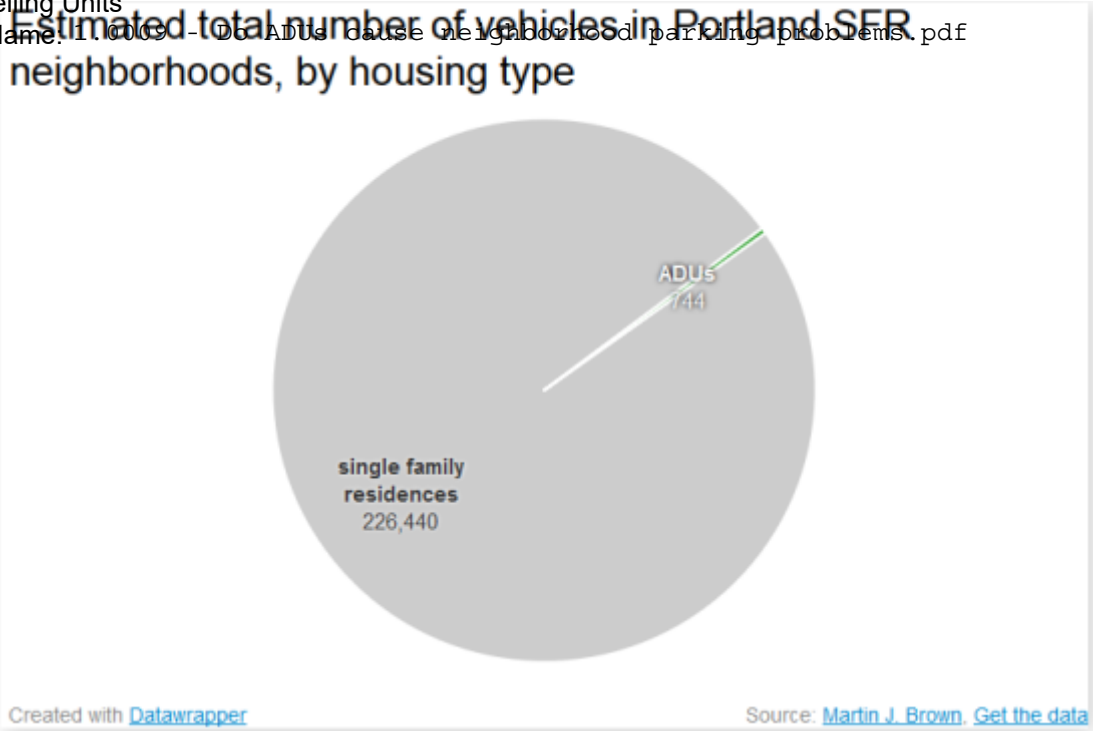

As you can see, ADUs contribute an insignificant sliver, 744 out of several hundred thousand. The number of ADU-related cars that are parked on the street is even smaller, since — even though Portland doesn't require dedicated parking for ADUs — about half of ADU-related cars are parked off-street.

That sliver is even smaller than it might be, because ADUs don't tend to come with as many cars as other types of housing. Here I've estimated the average number of cars per household in various kinds of housing, using statistics from the American Housing Survey and the DEQ survey mentioned above, as well as a study of "transit oriented developments" (TODs) in Portland.

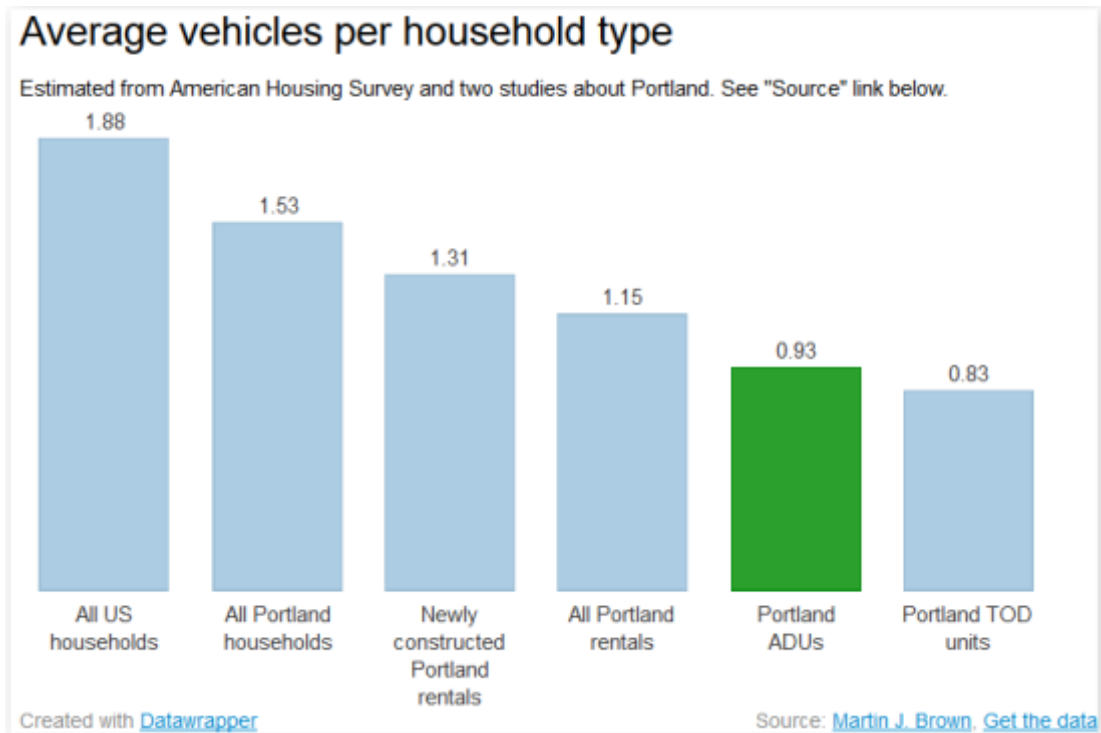

## Accessory Dwelling Units

Index # - File Name: 1.0009 - Do ADUs cause neighborhood parking problems.pdf

As you can see, the average American household has 1.88 vehicles associated with it. Portland is a little bit less car-oriented, with an overall average of 1.53. If you limit the examination to newly constructed Portland rentals (the best comparable for ADUs), the number is 1.31. ADUs themselves are less than half the American average at 0.93. The only form on the graph that beats ADUs is Portland “TODs” — large apartment blocks built on transit lines, with limited offstreet parking.

Curiously, TODs have caused an uproar among (usually-liberal) Portland residents near SE Division street, where TODs are concentrated. People say they have trouble parking. Meanwhile Portland’s 800 (probably 1000 by now) ADUs have caused no organized protest. It’s probably because ADUs are dispersed, so much that it can be hard to notice them.

I find this to be a fascinating contrast, because it shows that *how* development happens has a big impact on how people feel. Good development might be a reasonable alternative to zero development — which is a standard some people stick to when they feel their neighborhood is threatened.

“The last thing we need is more building and more density.”

wrote Columbia, Missouri, resident Raeona Nichols when ADUs were being debated in that town.

Zero development, as Ms. Nichols advocates, probably would prevent parking conditions from changing substantially. But is it realistic?

I think not. It seems impossible to hold anything as organic as a neighborhood in static state. Even without ADUs, neighborhoods will change as demographics, the economy, and other factors change. In a desirable town, population will increase, and some kind of increase in density will happen whether laws allow it or not. An increase in population inevitably means an increase in vehicles.

**The question isn’t so much “to densify or not?” but “how to densify?”**

Back in Raleigh, where efforts to allow ADUs failed, the *News & Observer* writes:

“Councilman Bonner Gaylord cast the lone vote against scrapping the [ADU] plan. He’s argued that they’d create a useful tool for growth. ‘This is the time to take the bold step forward,’ [Gaylord] said. ‘We know that we’re running out of land ... and how to densify is going to be a problem for the next 20 years.’”

**Whether ADUs are a good or bad policy for community development, there is absolutely no evidence they cause parking problems.** Because ADUs are extremely rare (Portland, the nation’s ADU “leader,” has them on less than 1% of eligible lots), and because ADU households have fewer cars than other households, *ADUs should have virtually no effect on parking conditions on a citywide basis.*

Now if there were *dense concentrations* of ADUs — for example, a city block where every single house had an ADU — there might be a noticeable effect on parking conditions. But that day is a long, long, long way off. Meanwhile, it is possible that ADUs could provide other civic benefits. Is it worth going without those benefits to “rein in” that tiny sliver of parking spaces?

—

*next week: Do ADUs serve the elderly?*

## About Martin John Brown



Martin John Brown is a researcher and consultant on environment and housing. Find out more at <http://martinjohnbrown.net>.

[View all posts by Martin John Brown](#) →

## 7 comments on “Do ADUs cause neighborhood parking problems?”

Pingback: [Are ADUs green housing? | Accessory Dwellings](#)

Pingback: [Research and policy about accessory dwelling units: introducing a 13-part series | Accessory Dwellings](#)

alan smith

July 29, 2014



I can't see the other comments – but parking is a sticking point here in austin as was noted. even with one required off-street space for the adu, there are complaints and comparisons to “stealth dorms”. I think the parking issue is a stand-in for something else

[Reply](#)

Pingback: [What are the barriers to ADU development? | Accessory Dwellings](#)

Pingback: [Summing up ADU research: are accessory dwelling units as great, or as horrible, as people say? | Accessory Dwellings](#)

Pingback: [Model Code for Accessory Dwelling Units | Accessory Dwellings](#)

Pingback: [To DADU or Not To DADU–Seattle’s ADU Debates | Accessory Dwellings](#)

This entry was posted on July 16, 2014 by [Martin John Brown](#) in [Policy & Trends](#) and tagged [accessory dwelling unit](#), [ADU](#), [cars](#), [featurepost](#), [nimby](#), [parking](#), [traffic](#).

<https://wp.me/p1R4v3-VM>

[Previous post](#)

[Next post](#)

[Blog at WordPress.com.](#)





NEW YORK CITY, NY ([HTTPS://WWW.RENTCAFE.COM/BLOG/CATEGORY/CITIES/NEW-YORK-CITY-NY/](https://www.rentcafe.com/blog/category/cities/new-york-city-ny/)) •  
 REAL ESTATE NEWS ([HTTPS://WWW.RENTCAFE.COM/BLOG/CATEGORY/RENTAL-MARKET/REAL-ESTATE-NEWS/](https://www.rentcafe.com/blog/category/rental-market/real-estate-news/)) •  
 RENTAL MARKET ([HTTPS://WWW.RENTCAFE.COM/BLOG/CATEGORY/RENTAL-MARKET/](https://www.rentcafe.com/blog/category/rental-market/)) •  
 SEATTLE, WA ([HTTPS://WWW.RENTCAFE.COM/BLOG/CATEGORY/CITIES/SEATTLE-WA/](https://www.rentcafe.com/blog/category/cities/seattle-wa/))

# As Apartments Are Shrinking, Seattle Tops New York with the Smallest Rentals in the U.S.

© November 30, 2018  10 Min Read



**176**

SHARES

 (<https://www.facebook.com>

 (<https://twitter.com>



 (<http://www.reddit.com>

Accessory Dwelling Units

Index # - File Name: 1.0010 - Average Apartment Size in the US.pdf

h	?	?
ar	te	u
er	xt	rl
.	=	=
p	A	ht
?	v	tp
u	er	s
=	a	%
ht	g	3
tp	e	A
s	%	%
%	2	2
3	0	F
A	A	%
%	p	2
2	ar	F
F	t	w
%	m	w
2	e	w
F	nt	.r
w	%	e
w	2	nt
w	0	c
.r	Si	af
e	z	e.
nt	e	c
c	%	o
af	2	m
e.	Oi	%
c	n	2
o	%	F
m	2	bl
%	Ot	o
2	h	%
F	%	2
bl	2	Fr
o	0	e
g	U	nt
%	S	al
2	%	-
Fr	3	m
e	A	ar
nt	%	k
al	2	et
-	0	%
m	S	2
ar	e	Fr
k	at	e
et	tl	al
%	e	-
2	%	e
Fr	2	st
e	0	at
al	H	e-
-	a	n
e	s	e
st	%	w
at	2	s
e-	Ot	%
n	h	2
e	e	F
w	%	u
s	2	s-

Accessory Dwelling Units

Index # - File Name: 1.0010 - Average Apartment Size in the US.pdf

0	a
2	v
F	er
u	a
s-	g
a	e-
v	a
er	p
a	ar
g	t
e-	m
a	e
p	nt
ar	s
t	&
m	u
e	rl
nt	=
-	ht
si	tp
z	s:
e-	//
tr	w
e	w
n	.r
d	e
s-	nt
d	c
o	af
w	e.
n	c
wa	o
r	m
d	/b
%	lo
2	g/
F)	re
	nt
	al
	-
	m
	ar
	k
	et
	/r
	e
	al
	-
	e
	st
	at
	e-
	n
	e
	w
	s/
	u
	s-
	a
	v
	er
	a
	g
	e-
	3
	A

Accessory Dwelling Units

Index # - File Name: 1.0010 - Average Apartment Size in the US.pdf

a  
p  
ar  
t  
m  
e  
nt  
-  
si  
z  
e-  
tr  
e  
n  
d  
s-  
d  
o  
w  
n  
w  
ar  
d/  
&  
vi  
a  
=  
R  
e  
nt  
C  
af  
e  
A  
pt  
s)

+  
S  
e  
at  
tl  
e  
+  
H  
a  
s  
+t  
h  
e  
+  
S  
m  
al  
le  
st  
+  
R  
e  
nt  
al  
s)

## Highlights:

- *The average size of new apartments in the U.S. in 2018 is 941 square feet, 5 percent smaller than ten years ago, with studio apartments shrinking the most, by more than 10 percent; meanwhile, overall rents have increased by 28% over the same period of time.*
- *The average size of apartments regardless of year built is 882 square feet, with the largest apartments in the Southeast boasting 975 square feet of living space and the smallest in California, measuring 837 square feet.*
- *Seattle has the tiniest apartments in the country, with an average size of 711 square feet, Manhattan and Chicago the second smallest rentals, 733 square feet, while Tallahassee, FL offers the most spacious rentals in the U.S., 1,038 square feet on average.*

As rental apartments have been growing in both popularity and price over the past decade, their floor plans have been slowly shrinking in size. The average size of a new apartment completed in 2018 in the U.S. is 941 square feet, 52 sqft less than the size of an apartment built ten years ago, according to our newest analysis of apartment sizes using Yardi Matrix data (<https://www.yardimatrix.com/>).

## Accessory Dwelling Units

Change in renters' living habits are literally redrawing floor plans. The largest share of apartment

Index #9 File Name: living habits are literally redrawing floor plans. The largest share of apartment dwellers, millennials prefer living in locations close to restaurants and entertainment (<https://www.rentcafe.com/blog/apartmentliving/lifestyle-apartmentliving/u-s-zip-codes-that-are-millennial-strongholds/>) rather than having a large kitchen or living room to cook or entertain at home. But the rising interest in smaller living spaces (<https://www.strawhomes.com/blog/2018/11/20/demand-for-smaller-condos-in-canada-vancouver-and-toronto/>) is equally motivated by price, as the need to save on rent sparks demand for smaller units. Unfortunately, renters are paying much more for less. **The average rent in newly-built apartments in the U.S. has increased by 28% compared to 10 years ago, while their size has gotten 5% smaller.**

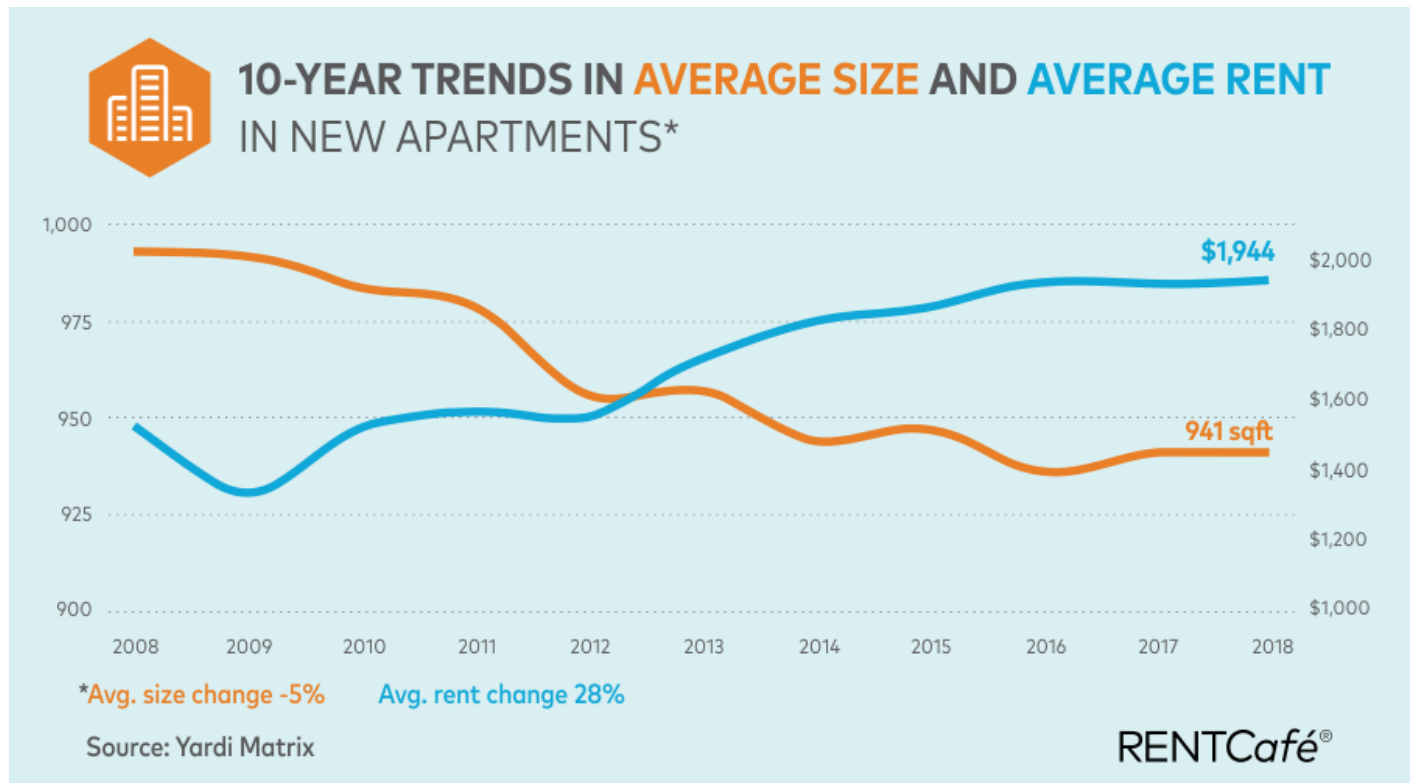

## Floor plans of all unit types are shrinking

Studio apartments — the symbol of downtown living — have been cut down the most. The average studio apartment is 10% smaller than 10 years ago, reduced from 573 sqft in 2008 to 514 sqft this year. Contrary to the growing interest in smaller units, studio apartments continue to represent a small piece of the rental market, only 5% nationally of all apartments (<https://www.rentcafe.com/blog/rental-market/real-estate-news/3-6-million-fewer-families-kids-home-compared-10-years-ago/>). One-bedroom rental units make up the largest chunk of the national apartment stock (43%) and their floor plans have decreased by 4% over the last decade, while two-bedroom apartments have seen the least change in size, down by only 0.5% on average.



## AVERAGE SIZE OF NEW APARTMENTS IN THE U.S.

Year Built	All	Studio	1 Bed	2 Bed
2008	993	573	790	1,132
2009	992	600	796	1,133
2010	984	614	787	1,147
2011	979	511	762	1,109
2012	956	493	752	1,092
2013	957	525	757	1,108
2014	944	536	751	1,113
2015	947	515	752	1,122
2016	936	503	752	1,121
2017	941	497	752	1,136
2018	941	514	757	1,138
<b>2018 vs. 2008</b>	<b>-5.2%</b>	<b>-10.3%</b>	<b>-4.2%</b>	<b>0.5%</b>

Source: Yardi Matrix

RENTCafé®

Overall, the average rental apartment size in the U.S. is 882 square feet, regardless of the year of completion. The average U.S. studio apartment has a square footage of 472 sqft, the size of a one-bedroom apartment is 714 sqft, while a two-bedroom apartment has an average living space of 1,006 sqft.

## APARTMENT SIZE BY REGION

### The largest apartments are in the SE, the smallest in CA

Rental apartments look very different from one region to another in terms of how spacious they are. **The largest rental units in the U.S. are located in the Southeastern region**, with a typical floor plan measuring 975 sqft, followed by apartments in the **South**, which are 943 sqft in size. The smallest apartments are, surprisingly, not in the Northeast (if you're automatically thinking New York), but rather in California. Renters in the Golden State make do with 837 sqft, on average, about 138 sqft less space than what renters in the Southeast are used to. Apartments in the Western region are the second smallest, measuring 893 sqft, on average.

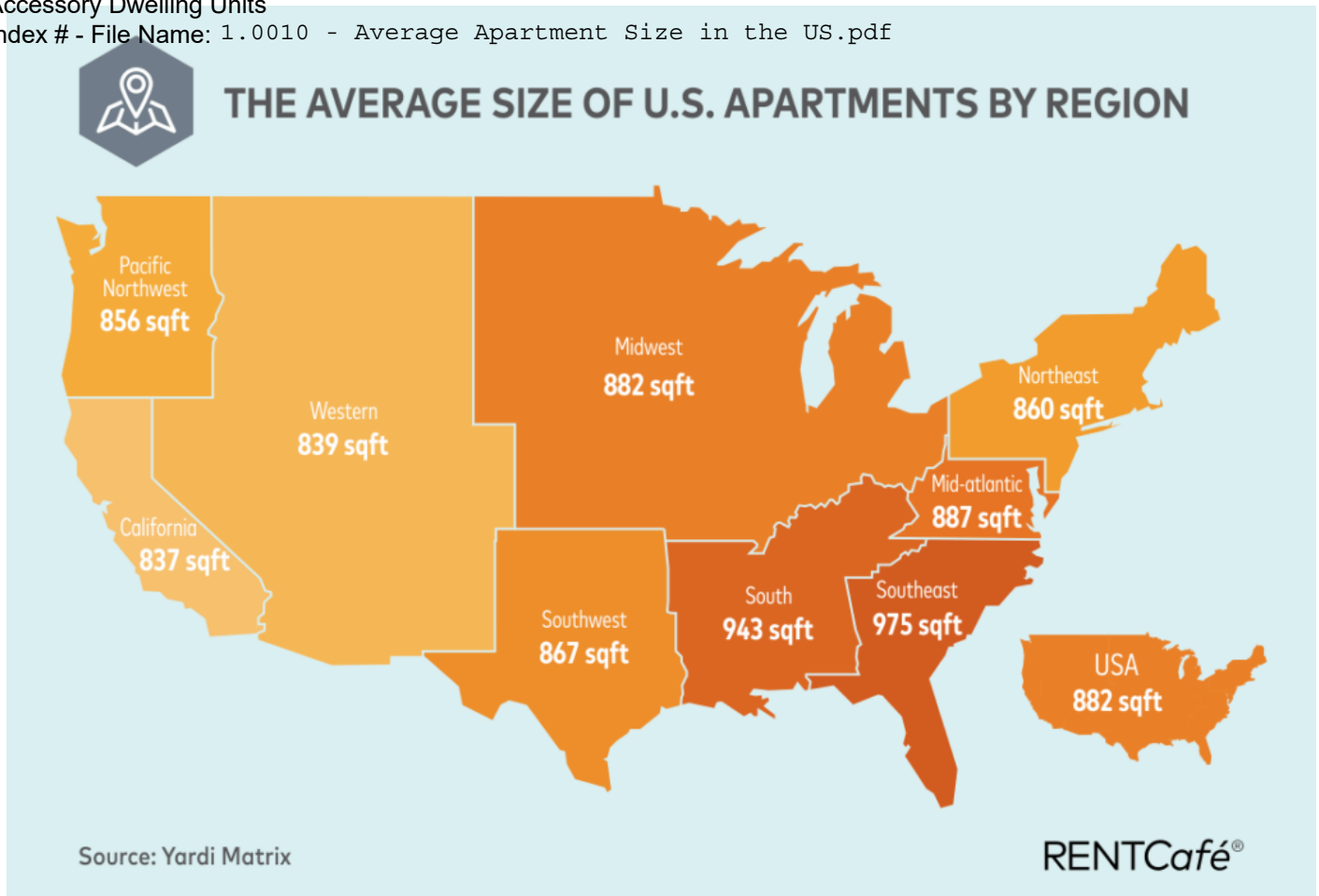

In terms of 10-year changes, apartments in California saw the biggest downsizing, 12%. The average Californian apartment is now 116 sqft smaller than 10 years ago, from 974 sqft to 858 sqft. New apartments in the Pacific Northwestern region offer the least elbow room, just 805 sqft, having gotten 10% smaller since 10 years ago. The Southeastern region continues to splurge in size, with the average new apartment sized at 1,007 sqft in 2018, more than 200 sqft larger than Washington and Oregon state rentals. The only region where apartments are constant in size is the Midwest, where the 10-year change is a 1% increase in the average apartment size.





## CHANGE IN NEW APARTMENT SIZE BY REGION

Region	Average Size (sqft) New Apartments 2008	Average Size (sqft) New Apartments 2018	10-Year Change
California	974	858	-12%
Northeast	1,048	945	-10%
Pacific Northwest	890	805	-10%
South	1,022	931	-9%
Western	1,011	938	-7%
Mid-Atlantic	951	886	-7%
Southwest	975	930	-5%
Southeast	1,049	1,007	-4%
Midwest	934	947	1%

Source: Yardi Matrix

RENTCafé®

## APARTMENT SIZE BY CITY

### Tallahassee and Seattle apartments are at opposite ends of the charts

We ranked the top 100 cities with the largest rental stock in the country by the average size of their rental apartments. Given that the Southeast has the largest apartments, it's not surprising that the top cities with the biggest rentals are in that area. **Tallahassee, FL** (<https://www.rentcafe.com/apartments-for-rent/us/fl/tallahassee/>) offers its renters the most generous apartment size in the country, with an average square footage of 1,038 sqft across all apartments regardless of the year built. Moreover, the average floorplan of a new apartment built in the state capital in 2018 is a lavish 1,200 sqft, unchanged from ten years ago.

**Atlanta** (<https://www.rentcafe.com/apartments-for-rent/us/ga/atlanta/>) and three of its suburbs take 4 of the top 10 spots for cities with the largest rental apartments in the nation. The second most spacious apartments in the U.S. are in Marietta, GA (<https://www.rentcafe.com/apartments-for-rent/us/ga/marietta/>), boasting an average size of 1,025 sqft. Decatur, GA (<https://www.rentcafe.com/apartments-for-rent/us/ga/decatour/>) is fourth with 1,000 sqft, Norcross, GA (<https://www.rentcafe.com/apartments-for-rent/us/ga/norcross/>) is sixth, with an average apartment size of 991 sqft. Apartments in Columbia, SC are the third largest in the U.S., with an average living space of 1,006 sqft. Large-size apartments tend to be more common in lower cost, sprawled cities or suburban areas than in high-cost dense urban areas.



It's rare that New York is not first in something real estate related. With an average size of 711 sqft, **Seattle** apartments (<https://www.rentcafe.com/apartments-for-rent/us/wa/seattle/>) offer 20 sqft less than an average Manhattan rental, 171 sqft less space than the national average apartment of 882 sqft, and a whole 327 less square feet than apartments in Tallahassee. **Manhattan** and **Chicago** (<https://www.rentcafe.com/apartments-for-rent/us/il/chicago/>) are tied in second place, with apartments measuring 733 sqft on average, 149 sqft below the national average. Rental apartments in Washington, DC (<https://www.rentcafe.com/apartments-for-rent/us/dc/washington/>) and San Francisco, CA (<https://www.rentcafe.com/apartments-for-rent/us/ca/san-francisco/>) wrap up the top 5 of the nation's tiniest apartments. Other firm believers in "less is more" are Los Angeles, Phoenix

Accessory Dwelling Units

(https://www.rentcafe.com/apartments-for-rent/us/az/phoenix/), Detroit, Minneapolis

Index # - File Name: 1-06-us-average-apartment-size-in-the-us.pdf

(https://www.rentcafe.com/apartments-for-rent/us/mn/minneapolis/), and Cleveland, with apartments below 800 sq feet in size.



See the full list of apartment sizes by unit type in 100 U.S. cities.

## Apartments in Detroit saw the biggest reduction in size since 2008

Accessory Dwelling Units

Apartment in Detroit

Index # File Name

Apartment in Detroit have suffered the biggest cuts in size in the last ten years. The average size of a new apartment in Motor City in 2018 is 27% smaller than ten years ago, 720 sqft today compared to 988 sqft a decade ago. New apartments built in Phoenix this year are on average 871 sqft, 19% smaller than they were in 2008. Los Angeles apartments (<https://www.rentcafe.com/apartments-for-rent/us/ca/los-angeles/>), Boston apartments (<https://www.rentcafe.com/apartments-for-rent/us/ma/boston/>), and Irvine, CA apartments (<https://www.rentcafe.com/apartments-for-rent/us/ca/irvine/>) are also in the top 5 in terms of size reduction.

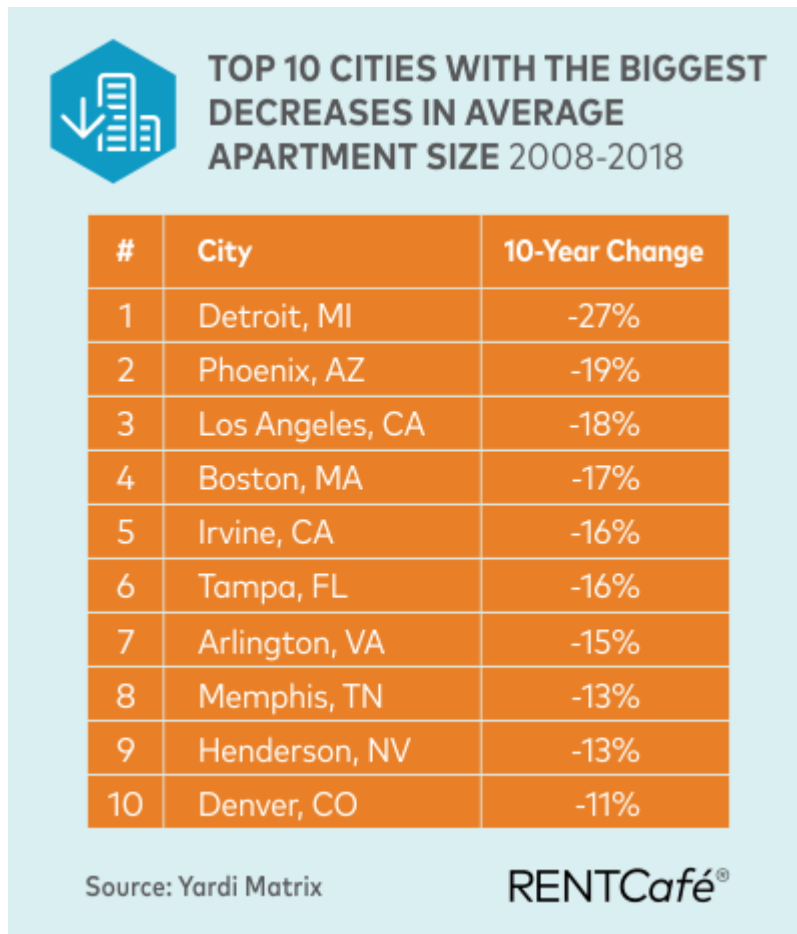

Rental apartments in Lubbock, TX, on the other hand, have seen a sizeable increase in space over the last decade, up 19%. Apartments built in Lubbock in 2018 average as much as 1,326 sq ft in size. New rentals in Lewisville, TX are only 891 sqft, an increase of 17% over 2008. Although rentals in San Francisco and Manhattan are among the smallest in the nation, they have been increasing in size in recent years, up by 13% and 12%, respectively, compared to 10 years prior. The newest apartments in San Francisco opened this year have an average size of 840 sqft. Newly-completed Manhattan apartments are on average 802 sq ft in size. Baltimore and Miami apartments (<https://www.rentcafe.com/apartments-for-rent/us/fl/miami/>) have each gained 9% in size on average. New apartments in Baltimore measure 871 sq ft on average, this year, while those in Miami 834 sqft.

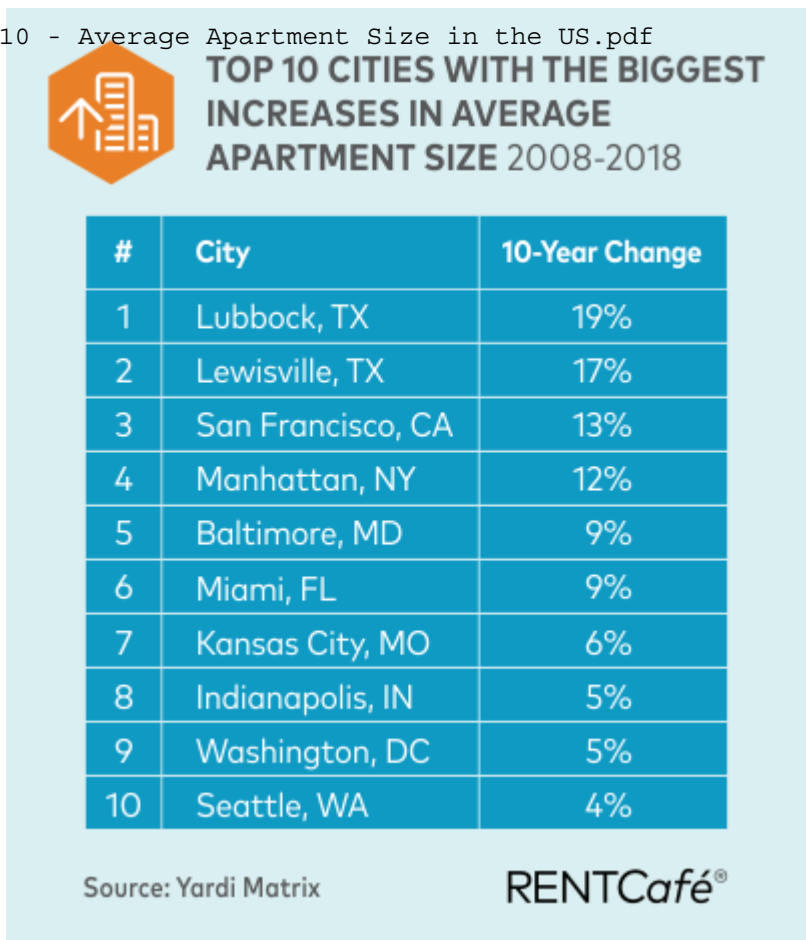

## Ten-year changes in apartment rents and sizes

A few cities have seen dramatic changes in rents and size in opposite directions over the past decade. As Denver (<https://www.rentcafe.com/apartments-for-rent/us/co/denver/>) became one of the hottest rental markets in the country, apartment rents jumped 84% in the last 10 years, while the average size of apartments decreased by 11%. Nearby Colorado Springs saw a similar path, with rents up 66% and rental sizes down 6%. Another hot market, Seattle saw rent prices increase by 74% in 10 years, while the size of apartments increased by 4%. Renting in tech valley San Jose, CA today is 63% more expensive than a decade ago, while new apartments in the area are 4% smaller.

Show  entries Search:

City*	Size 2008	Size 2018	Change in Size	Rent 2008	Rent 2018	Change in Rent
Denver, CO	942	841	-11%	\$872	\$1,601	84%
Colorado Springs, CO	1,007	947	-6%	\$674	\$1,119	66%
Seattle, WA	683	711	4%	\$1,186	\$2,064	74%

Accessory Dwelling Units

Index # - File Name: 1.0010 - Average Apartment Size in the US.pdf

City*	Size 2008	Size 2018	Change in Size	Rent 2008	Rent 2018	Change in Rent
San Jose, CA	881	844	-4%	\$1,666	\$2,722	63%
Tampa, FL ( <a href="https://www.rentcafe.com/apartments-for-rent/us/fl/hillsborough-county/tampa/">https://www.rentcafe.com/apartments-for-rent/us/fl/hillsborough-county/tampa/</a> )	1,129	952	-16%	\$864	\$1,302	51%
Portland, OR ( <a href="https://www.rentcafe.com/apartments-for-rent/us/or/portland/">https://www.rentcafe.com/apartments-for-rent/us/or/portland/</a> )	748	707	-5%	\$946	\$1,510	60%
Los Angeles, CA	888	729	-18%	\$1,649	\$2,404	46%
Austin, TX ( <a href="https://www.rentcafe.com/apartments-for-rent/us/tx/austin/">https://www.rentcafe.com/apartments-for-rent/us/tx/austin/</a> )	955	878	-8%	\$869	\$1,347	55%
Orlando, FL	1,153	1,030	-11%	\$952	\$1,388	46%
Dallas, TX ( <a href="https://www.rentcafe.com/apartments-for-rent/us/tx/dallas/">https://www.rentcafe.com/apartments-for-rent/us/tx/dallas/</a> )	1,033	952	-8%	\$795	\$1,179	48%

Showing 1 to 10 of 30 entries

[◀ Previous](#)
[Next ▶](#)

*\*Ten-year historical rent data not available in cities not listed.*

## Atlanta boasts the largest one-bedroom and two-bedroom floor plans in the U.S.

The largest studio apartments are in Irvine, CA, with an average floor plan of 586 sqft. Renters searching for a spacious one-bedroom rental will find the largest ones in Atlanta, GA, with 786 sqft of living space. Atlanta also offers the largest two-bedroom apartments, at 1,124 sqft, on average.

The tiniest studio apartments in the country are in **Reno, NV**, offering just 349 sqft of living space, on average, so tiny they could qualify as micro-apartments in other parts of the country. Then there are places where the size-standard of rental apartments is low by definition. **Tucson, AZ** is such a place. It has the smallest one-bedroom apartments in the U.S., measuring just 595 sqft, as well as the smallest two-bedroom apartments, which have an average size of 906 sqft.

# Check the Average Apartment Size (sq. ft.) in 100 Largest U.S. Cities for Renters:

Show  entries

Search:

#	City	State	ALL	Studio	1 Bedroom	2 Bedroom
1	Tallahassee	FL	1,038	376	697	1,011
2	Marietta	GA	1,025	551	780	1,119
3	Columbia	SC	1,006	475	731	1,048
4	Decatur	GA	1,000	551	772	1,077
5	Birmingham	AL	992	463	784	1,072
6	Norcross	GA	991	519	759	1,090
7	Gainesville	FL	990	394	670	999
8	Atlanta	GA	987	561	786	1,124
9	Virginia Beach	VA	973	467	754	1,029
10	Henderson	NV	970	537	742	1,052

Showing 1 to 10 of 100 entries

[◀ Previous](#) [Next ▶](#)

## Methodology

This report was compiled by RentCafe.com (<https://www.rentcafe.com/>), a nationwide apartment search website that enables renters to easily find apartments and houses for rent throughout the United States. The apartment size and rent data were provided by Yardi Matrix (<https://www.yardimatrix.com/>), a RENTCafé sister company specialized in apartment market intelligence, providing up-to-date information on large-scale multi-family properties of 50 units or more in over 130 U.S. markets.

Unit types are categorized by the number of bedrooms (zero, one, two) as defined by Yardi Matrix. (<https://www.yardimatrix.com/About-Us/Our-Methods/How-We-Define-The-Apartment-Supply/Unit-Types>) The regions included in this report coincide with Yardi Matrix's market boundaries (<https://www.yardimatrix.com/Markets>) and may be different from regional boundaries as defined by other sources.

Accessory Dwelling Units

Rankings are based on the top 100 U.S. cities with the largest stock of apartments (sometimes referred to as "largest cities for renters") located in multi-family buildings of 50 units or more. To ensure a relevant sample size, we excluded cities where the number of units completed in one year was below 300 units. In the rare instances where no apartment data was available for 2018, the data for 2017 was used instead. Similarly, where no apartment data was available for 2008, data for 2009 was used instead. New York City data is available for the Manhattan borough only.

For custom reports on specific markets, please contact our research team at [media@rentcafe.com](mailto:media@rentcafe.com) (<mailto:media@rentcafe.com>).

*This article is an updated version of a RENTCafe story published in 2016, which can be found here (<https://www.rentcafe.com/blog/rental-market/real-estate-news/us-apartment-size-2016/>).*

### Fair use and redistribution

We encourage you and freely grant you permission to reuse, host, or repost the images in this article. When doing so, we only ask that you kindly attribute the authors by linking to RENTCafe.com (<https://www.rentcafe.com>) or this page, so that your readers can learn more about this project, the research behind it and its methodology.

176  
SHARES



(h  
tt  
p  
s:  
//  
w  
w  
w  
.f  
a  
c  
e  
b  
o  
o  
k.  
c  
o  
m  
/s  
h  
ar  
er  
.p  
h  
p  
?  
u  
=  
ht  
tp  
s



(h  
tt  
p  
s:  
//  
t  
w  
itt  
er  
.c  
o  
m  
/i  
nt  
e  
nt  
/t  
w  
e  
et  
?  
te  
xt  
=  
A  
v  
er  
a  
g  
e  
%



(h  
tt  
p:  
//  
w  
w  
w  
.r  
e  
d  
di  
t.  
c  
o  
m  
/s  
u  
b  
m  
it  
?  
u  
rl  
=  
ht  
tp  
s  
%  
3  
A  
%



(h  
tt  
p:  
//  
w  
w  
w  
.r  
e  
d  
di  
t.  
c  
o  
m  
/s  
u  
b  
m  
it  
?  
u  
rl  
=  
ht  
tp  
s  
%  
3  
A  
%



Accessory Dwelling Units

Index # - File Name

1.0010 - Average Apartment Size in the US.pdf

Average Apartment Size in the US.pdf

Accessory Dwelling Units

Index # - File Name: 1.0010 - Average Apartment Size in the US.pdf

ar	S	-
t	&	Si
m	u	z
e	rl	e-
nt	=	tr
-	ht	e
si	tp	n
z	s:	d
e-	//	s-
tr	w	d
e	w	o
n	w	w
d	.r	n
s-	e	w
d	nt	ar
o	c	d
w	af	%
n	e.	2
w	c	F
ar	o	&
d	m	tit
%	/b	le
2	log/	=
F)	re	A
	nt	v
	al	er
	-	a
	m	g
	ar	e
	k	+
	et	A
	/r	p
	e	ar
	al	t
	-	m
	e	e
	st	nt
	at	+
	e-	Si
	n	z
	e	e
	w	+i
	s/	n
	u	+t
	s-	h
	a	e
	v	+
	er	U
	a	S
	g	%
	e-	3
	a	A
	p	+
	ar	S
	t	e
	m	at
	e	tl
	nt	e
	-	+
	si	H
	z	a
	e-	s
	tr	+t
	e	h
		e

Accessory Dwelling Units

Index # - File Name: 1.0010 - Average Apartment Size in the US.pdf

n  
d  
s-  
d  
o  
w  
n  
w  
ar  
d/  
&  
vi  
a  
=  
R  
e  
nt  
C  
af  
e  
A  
pt  
s)

+  
S  
m  
al  
le  
st  
+  
R  
e  
nt  
al  
s)

### About the author



### Nadia Balint

Nadia Balint is a senior creative writer for RENTCafé. She covers news and trends in residential and commercial real estate and their impact on our everyday life, including rental housing, for-sale housing, real estate development, homeownership, market reports, insurance, landlord-tenant laws, personal finance, urban development, economy, sustainability, and social issues. Nadia holds a B.S. in Business Management from Northeastern Illinois University in Chicago. You can connect with Nadia via email (<mailto:nadia.balint@yardi.com>).



# JUMPSTARTING THE MARKET FOR ACCESSORY DWELLING UNITS:

*LESSONS LEARNED FROM PORTLAND, SEATTLE AND VANCOUVER*

Karen Chapple, Jake Wegmann, Farzad Mashhood, and Rebecca Coleman



**TEXAS**  
The University of Texas at Austin



**Urban Land Institute** San Francisco  
Serving the Greater Bay Area



CENTER FOR COMMUNITY INNOVATION

**TERNER CENTER**  
**FOR HOUSING INNOVATION**  
**UC BERKELEY**

This report was prepared for and funded by the San Francisco chapter of the Urban Land Institute.

Cover Photo credit: Clockwise from top left: Accessory Dwellings, <http://www.accessorydwellings.org>; Karen Chapple; Accessory Dwellings, <http://www.accessorydwellings.org>; Accessory Dwellings, <http://www.accessorydwellings.org>.

Acknowledgements: The authors are grateful to ULI Executive Director Michelle Malanca Frey, ULI Director Natalie Sandoval, Turner Center Director Carol Galante, and Turner Center Associate Director Sara Draper-Zivetz for their comments. We also wish to thank city staff and other interviewees in Portland, Seattle, and Vancouver for their help. All remaining errors are our own.

**The Urban Land Institute's** mission is to provide leadership in the responsible use of land and in creating and sustaining thriving communities worldwide. ULI San Francisco carries forth that mission by serving the Bay Area's public and private sectors with pragmatic land use expertise and education.

**The Turner Center for Housing Innovation** formulates bold strategies to house families from all walks of life in vibrant, sustainable, and affordable homes and communities.

**The Center for Community Innovation's** mission is to nurture effective solutions that expand economic opportunity, diversify housing options, and strengthen connection to place.

# Contents

4	Why Accessory Dwelling Units?
5	Understanding the Barriers to ADUs
7	Stories of Success: Portland, Seattle, and Vancouver
14	The Role of ADU Reform
14	Survey Methodology
15	ADUs in the Survey: What Do They Look Like, How Were They Built, and How Are They Used?
19	Challenges and Opportunities
23	Conclusion and Policy Implications
24	Notes
27	Appendix A: ADU Regulations
28	Appendix B: Survey Methodology

## WHY ACCESSORY DWELLING UNITS?

Across the United States, communities are experiencing challenges in building the housing they need to maintain affordability and accommodate future growth. Accessory dwelling units (ADUs), or separate small dwellings embedded within single-family residential properties, are an effective solution due to their low cost and immediate feasibility, with homeowners building in their own backyards.<sup>1</sup> In fact, California researchers suggest that such small-scale infill development could account for as much as half of new development capacity in coming decades.<sup>2</sup> Many cities and states have recently passed legislation easing zoning and permitting regulations for ADUs, most notably Senate Bill 1069/Assembly Bill 2299 in California, signed into law on January 1, 2017.<sup>3</sup>

Despite government attempts to reduce barriers, a widespread surge of ADU construction has not materialized.<sup>4</sup> The ADU market remains stalled. To find out why, this study looks at three cities in the Pacific Northwest of the United States and Canada that have seen a spike in construction in recent years: Portland, Seattle, and Vancouver. Each city has adopted a set of zoning reforms, sometimes in combination with financial incentives and outreach programs, to spur ADU construction. Due to these changes as well as the acceleration of the housing crisis in each city, ADUs have begun blossoming.

Based on a homeowner survey and stakeholder interviews, this report tells the story of successful ADU implementation in the three cities, to help policymakers enact more effective reforms. Homeowners in these cities have embraced ADUs because of the flexibility these units provide, with the ability to use the space as housing or office, for rental income or a friend/family member in need, depending on the circumstances. Because construction costs are relatively low, the housing produced is generally affordable: the majority of new ADUs are leased for below-market rents. Many homeowners experienced barriers in terms of zoning, permitting, or finance, but solutions emerged, often due to city actions.

The report begins with a brief review of previous research on barriers to identify the gaps in our knowledge. It then describes the context for ADUs in the three cities, including the policies each implemented to spur more construction. Next, the report turns to the survey methods and results. A conclusion suggests policy approaches to spur more ADU construction. Most prominent among them are efforts to make loans for ADU projects more accessible to more homeowners. This would be a difficult undertaking but one with a likely high payoff. In addition, providing city-approved manuals detailing the regulatory, design, and project management processes for ADU projects for homeowners, coupled with technical assistance and promotional efforts would also likely help boost production.

## UNDERSTANDING THE BARRIERS TO ADUS

Several factors clearly deter homeowners from constructing ADUs. Most prominent are the zoning and permitting barriers, including the building and lot regulations and permitting fees. These not only can make building an ADU physically infeasible, but also can constitute a psychological barrier for homeowners who already have minor code violations or face neighbor opposition with regard to new construction. Lack of capital is another challenge, with lenders hesitant to develop loan products tailored to this housing type. At a most basic level, homeowners—and even contractors—lack experience with the overall process, and can be too intimidated to even start.

Zoning laws put in place since the post-World War II housing boom have largely restricted ADU development in many US contexts.<sup>5</sup> Historically, even when states like California have taken specific steps to undo restrictive zoning practices, local governments continued to impose burdensome regulatory requirements and delay enactment of local laws.<sup>6</sup> Restrictions on parking, lot size, and setbacks can render ADU construction prohibitively expensive or impossible on many lots.<sup>7</sup> Beyond specific zoning practices, neighborhood group opposition to increased density can deter policymakers from allowing ADUs.<sup>8</sup> Yet, organized efforts to reverse regulatory barriers have increased, beginning with the American Association of Retired Persons, which wrote a model state law in 2000, and are now apparent in websites like [accessorydwellings.org](http://accessorydwellings.org).<sup>9</sup>

Many studies have explored financial barriers, including high upfront costs and the inability to access loans.<sup>10</sup> A study of Oregon ADU owners found that most owners actually built theirs out of cash savings.<sup>11</sup> Developers may not see adding an ADU as providing enough of a profit margin.<sup>12</sup> Structural challenges also make borrowing for an ADU difficult. Most lending institutions do not allow appraisals to factor in the expected rental income from an ADU to estimate market value of a residential property. Because of this and other factors, homes with ADUs were found in one study to be undervalued by up to 9.8%.<sup>13</sup>

Another barrier can be the experience level of the ADU developer. Those building ADUs tend to be homeowners unfamiliar with real estate and construction and see building an ADU as a major and risky project.<sup>14</sup> Navigating zoning and building codes could be a barrier for those not experienced with development, or concerned about city inspectors flagging unrelated code violations on their lot.<sup>15</sup>

The greater variety and prevalence of rental housing in Canada raise questions about how the institutional context may shape construction. For example, secondary suites (to use a Canadian term largely equivalent to attached ADUs)—both legal and illegal—have long been an important supply of rental housing across cities, towns, and rural areas.<sup>16</sup> In order to encourage the upgrading of units to meet building, fire and safety standards, many local governments have developed popular programs that provide inter-



ADU in Portland, photo credit: Tom Hudson's ADU, <http://www.accessorydwellings.org>.



est-free loans and forgivable grants.<sup>17</sup> Because the National Model Construction Codes provide the basis for provincial codes, regulations tend to be similar across municipalities, a streamlining that may aid developers.<sup>18</sup>

In addition to these regulatory and financial barriers, other contextual factors may affect how many ADUs get built. For instance, in some regions, ADUs are already part of the landscape, whether because of the architectural vernacular (in places where in-law units have commonly been built), cultural practices of multigenerational living, or high housing demand from immigrants, students, and other groups facing rental housing shortages (many living in unpermitted dwellings). In others, such as planned subdivisions or common interest developments managed by owners' associations, ADUs are rare or nonexistent. Likewise, a region's topography and amount of buildable land can shape ADU construction patterns; one obvious example is San Francisco, which has seen considerable backyard living due in part to its constrained geography.

What can cities do to spur implementation? A few case studies provide examples. The Austin Community Design and Development Center provides design and planning assistance to low- and moderate-income households and also partners with another venture to help build and manage ADUs on people's properties.<sup>19</sup> The City of Santa Cruz is often cited as a model for implementation, due to its multi-pronged approach to encouraging ADU construction via an ADU manual, architectural prototypes, loan fund, fee waivers, and community workshops.<sup>20</sup> Most recently, a local Habitat for Humanity branch has created the pilot My House My Home program to assist with ADU construction, allowing seniors to age in place.<sup>21</sup> However, no studies to date have identified which interventions work best to spur production. A deeper look at the success stories in the Pacific Northwest can help other cities devise successful ADU reforms.



ADU in Portland, photo credit: Susan Moray's ADU, <http://www.accessorydwellings.org>.

## STORIES OF SUCCESS: PORTLAND, SEATTLE, AND VANCOUVER

As cities around the country try to ramp up ADU production, many look to the three large cities considered North American ADU leaders: Portland, Seattle, and Vancouver. The three share a regional ecological context (often called “Cascadia”) and hot housing markets: in all three cities, housing prices have increased in recent decades, particularly the past five years (Figure 1). As described next, interviews with local experts helped identify key factors behind the success in each city. For a description of ADU regulations in each city, please see Appendix A.



Figure 1. Percent Change in Housing Prices (2000=100).

Sources: House Price Index, Federal Housing Finance Authority (Seattle and Portland); House Price Index, Teranet and National Bank of Canada (Vancouver); Consumer Price Index, US Bureau of Labor Statistics.

## PORTLAND



ADU in Portland, photo credit: Kristy Lakin's ADU, <http://www.accessorydwellings.org>.

In the U.S., Portland, Oregon stands out for its success in enabling ADU construction. The city has seen a boom in ADU building in recent years: almost 2,000 ADU permits have been issued since 2010 (Figure 2).<sup>22</sup>

Portland's success can be attributed to a combination of regulatory, financial, and social factors:

- **Regulatory:** Portland stands out as one of the most progressive cities in the U.S. in terms of having permissive ADU regulations. The city has no owner occupancy requirement, no design review, a by-right process, and fee waivers.
- **Financial:** in 2010 the city waived one time System Development Charges (SDC) fees based on the new or increased use of a property (impact fees for parks, sewers, water, and streets that average 7% of the total cost of a new home)—a critical step to paving the way to more ADU production.<sup>23</sup>
- **Social:** in 2008 and 2009, green building advocates joined forces with ADU advocates to host bike tours and additional educational events. This educational push by the two different constituencies has gone a long way in increasing awareness and popularity of ADUs.<sup>24</sup>

*The importance of the system development charge waiver from the City of Portland for ADU's cannot be overstated. On my ~\$30k project, SDC's would have amounted to \$10-15k, making the project impossible.*  
—Portland homeowner

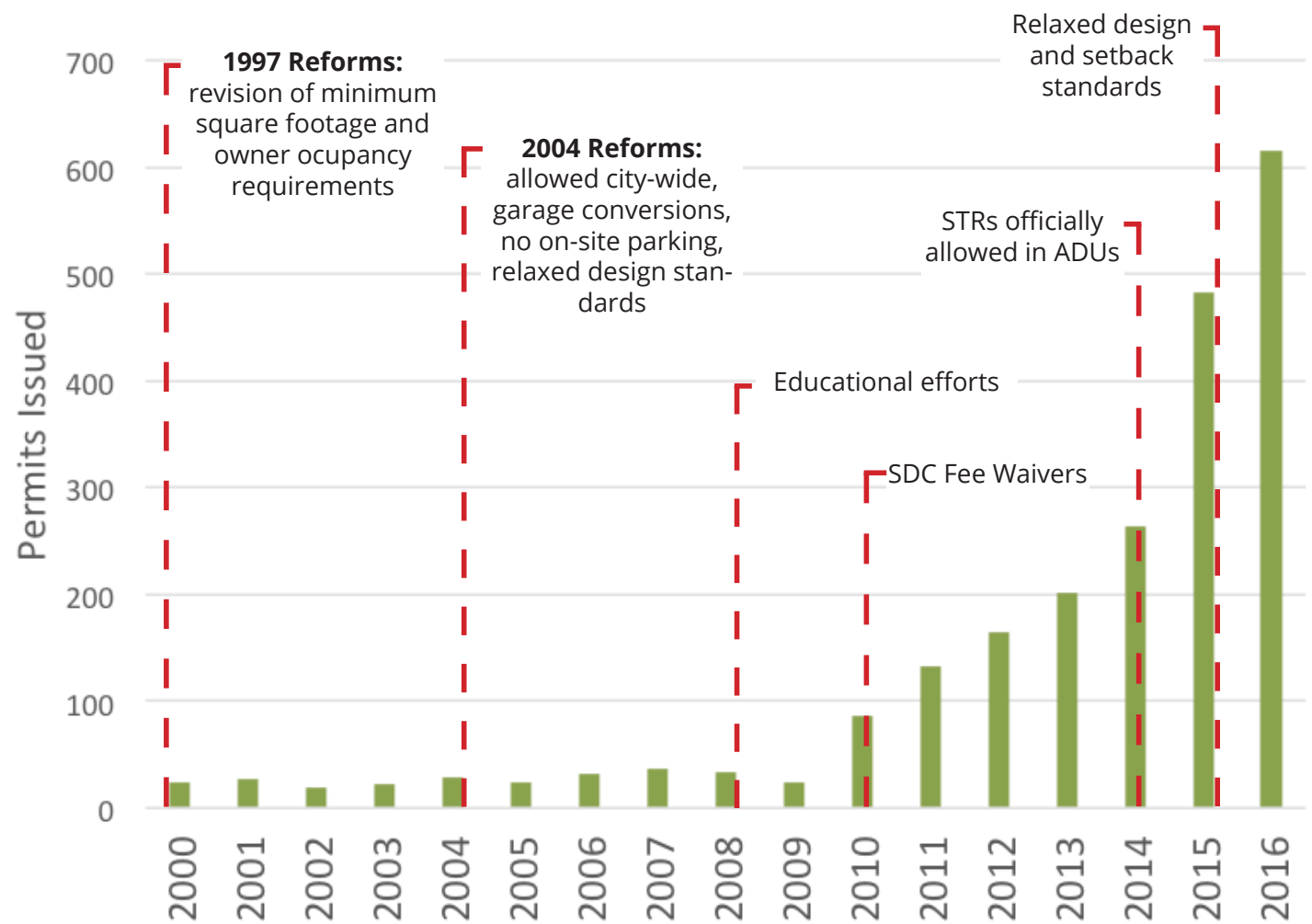

Figure 2. ADU permitting and reforms in Portland.

In addition to its hot housing market, Portland also features a supportive demographic in its aging population: Portland ADUs may be particularly well suited to serve older persons since they are disproportionately owned by 55-64 year olds.<sup>25</sup>

Portland advocates continue to push for more reforms. Advocates are currently working to bring back a loan product called 80/20 loans that had been available before the mortgage crisis. These loans made it possible to take out a second mortgage based on the improvement value of the new ADU. Another idea in the works is to develop a financing program similar to the property-assessed clean energy (PACE) model, which allows governments to finance the up-front cost of energy improvements, subject to repayment by the property owners.

## SEATTLE

Likewise, Seattle has experienced a growth spurt in ADU permitting and construction (Figure 3). However, this is perhaps due less to zoning reforms than to a hot housing market and an ongoing public discussion about potential policy reforms.

Seattle has allowed attached ADUs since the mid-1990s and detached ADUs (DADUs) since 2006 (Figure 3). From 2006 to 2009 a pilot program allowed DADUs to be constructed in specific areas. It went very well, leading the city to extend the program across Seattle in 2010. Until 2014, production was consistent but slow, but as the city began to study options to increase production, permit activity increased. After the city released this study and prompted further public discussion, even bolder changes were proposed, including removing parking requirements, changing owner occupancy requirements, and allowing both attached and detached ADUs.<sup>26</sup>



Seattle ADU, photo credit: City of Seattle.

To date, most ADU applications have come from wealthier homeowners, due in part to the escalating cost of construction (as much as \$250-300 per square foot). Still, city staff argue that because even new ADUs typically rent for less than conventional housing units, they provide a relatively affordable option in Seattle's expensive neighborhoods.

Jumpstarting the Market for ADUs

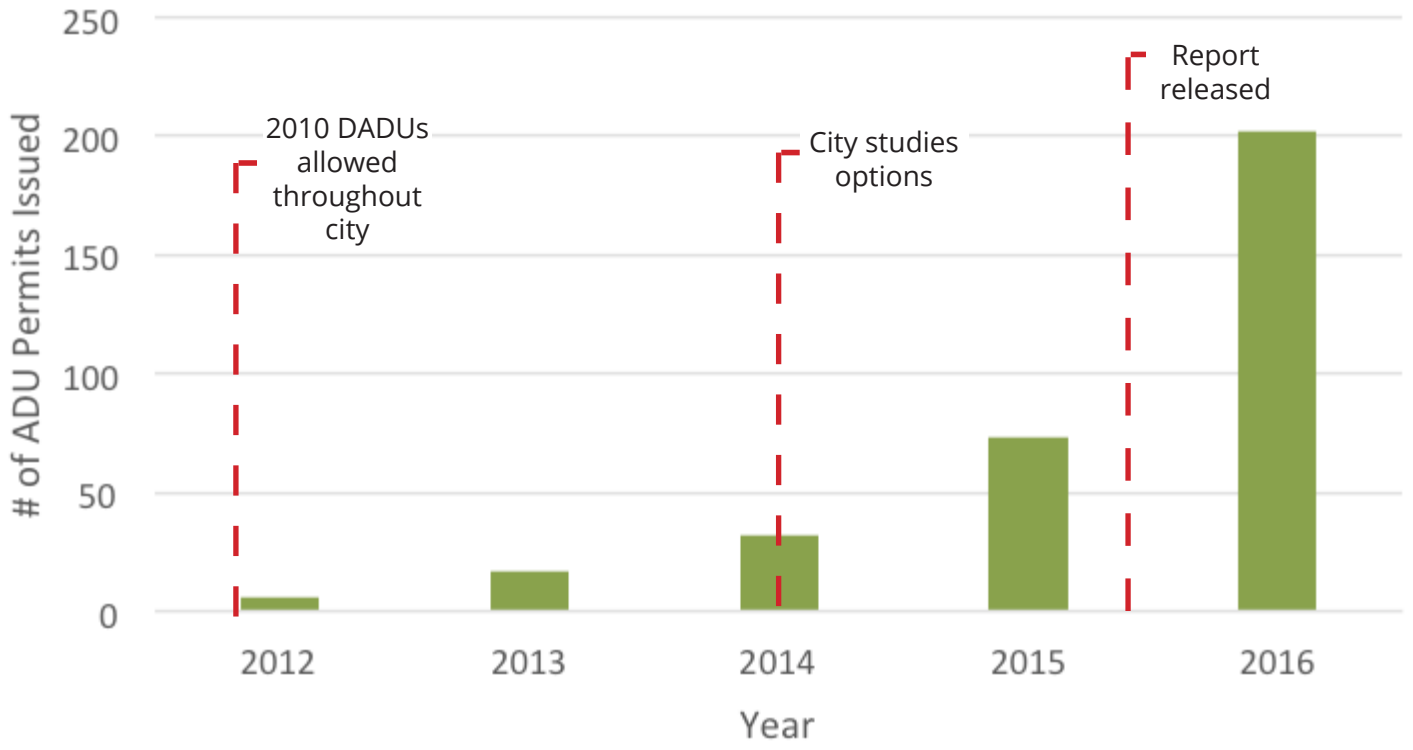

Figure 3. ADU permitting and reforms in Seattle.



Seattle ADUs, photo credit: City of Seattle.

## VANCOUVER

In Vancouver, the context for ADU construction was set by a decades-long battle over secondary suites. Secondary suites are basement or ground-floor apartments in single-family houses. Originally encouraged during World War II to alleviate housing shortages, secondary suites, many of which were not built to code, were subsequently considered a nuisance and made illegal; for three decades, the Council repeatedly passed legislation to improve enforcement. In the 1980s, Vancouver finally made it legal to house secondary suites in half of the city's single-family zones, and in 2004, permitted secondary suites citywide. A 2009 study found that there were at least 25,000 suites in Vancouver, most providing relatively affordable housing within less expensive homes.<sup>27</sup> Although the City has attempted to create a path to legalize secondary suites, the majority (with the exception of recently constructed units) remain illegal. Legal secondary suites are now often included in new single-family homes: between 2010 and 2015, 1,937 of the single-family homes built had secondary suites.<sup>28</sup>



Secondary suite in Vancouver, photo credit: Karen Chapple.

In the context of a hot housing market and a lack of vacant land, a new movement also began supporting new legislation to build laneway houses, or small detached houses built on single family lots facing the alley (or the “lane” in Canadian parlance). Vancouver’s urban form—with its grid layout, alleys intersecting many blocks, and deep residential lots (typically 33’ x 122’)—have made laneway dwellings possible. Support also came from the 2006 Vancouver Eco-Density Initiative, a city-led push to reduce greenhouse gas emissions, reuse infrastructure, and foster new green systems through more dense land use. The Council adopted laneway house regulations for the two largest single-family home districts in 2010, and then passed amendments allowing the dwellings citywide in 2013 (Figure 4). This last set of reforms permitted extra floor area (up to 940 square feet), eliminated the garage requirement (replacing it with an external parking pad), and allowed ministerial approval. There is no owner occupancy requirement for Vancouver’s laneway houses. Notably, institutions like Vancity, a local financial co-operative, provide loan products that are appropriate for laneway dwellings, for instance by allowing homeowners to count rental revenue as part of their income.

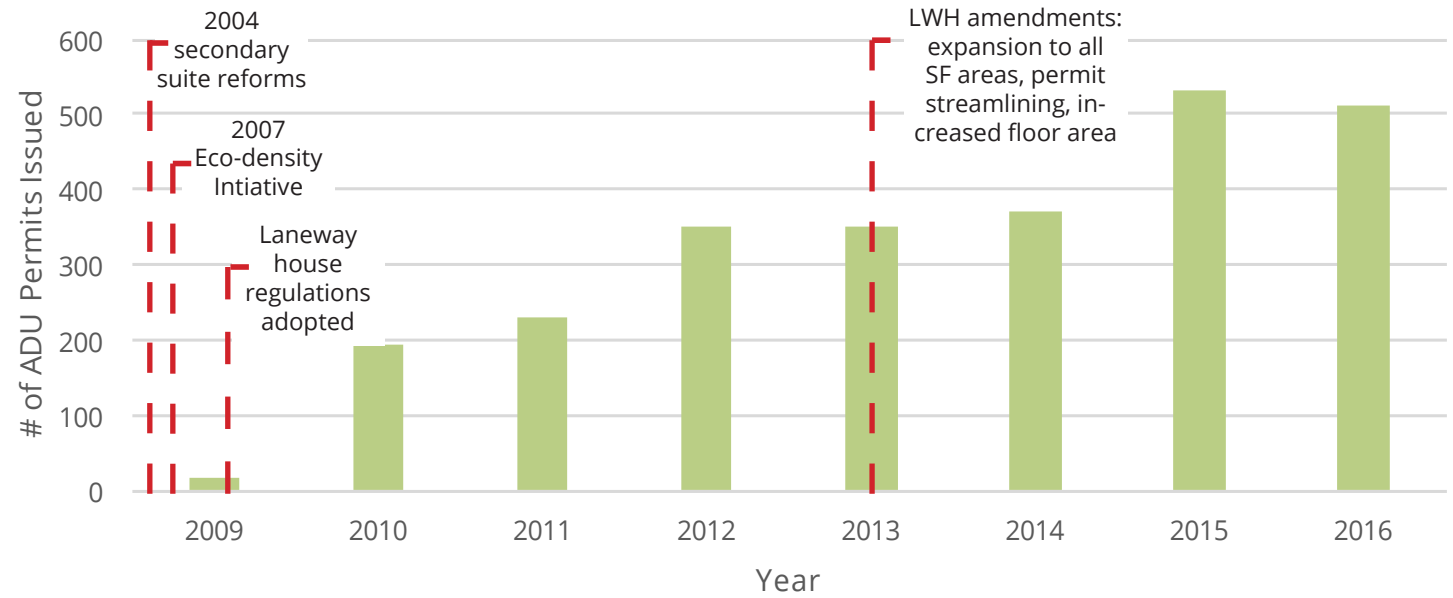

Figure 4. ADU (laneway housing) permitting and reforms in Vancouver.

Vancouver’s design context—the lanes and walkability of the city—as well as its high housing prices clearly contribute to the spurt in ADU construction. However, another key to its success has been the proactive and ongoing efforts by the city to provide technical assistance to homeowners and to amend ordinances to make it easier for homeowners to build. Careful design guidelines ensure that the new laneway houses will not intrude on the neighbors: decks and balconies are oriented to the lane, the upper floor has just 60% of the floor area of the main floor, there is a 16’ separation from the main house, and a 3’ landscaped setback at the lane. At present, there is more demand than the city can accommodate, and permitting is considerably backlogged.



Laneway house in Vancouver, photo credit: Karen Chapple.



## THE ROLE OF ADU REFORM

These three cases illustrate how ADU reform in a hot housing market can allow this dwelling type to play a major role in a city's mix of housing options. In Portland, Seattle, and Vancouver, ADUs accounted for only 3.0%, 0.8%, and 0.6%, respectively, of issued housing permits in 2009. In 2015, following key reforms in all three cities, this share had risen to 10.9%, 2.1%, and 6.3%, respectively.<sup>29</sup>

Similar cities that have only recently enacted zoning reforms demonstrate slower progress. Like the Cascadia cities reviewed in this report, both Salt Lake City, Utah and Austin, Texas have hot housing markets.<sup>30</sup> Yet, in Salt Lake City, only one ADU had been permitted in the city since September 2012 when the City Council adopted an ordinance permitting ADUs as of September 2015. The city is currently considering regulatory changes to requirements related to location, permit limit, building height, maximum square footage, lot area, and parking to jumpstart the market.<sup>31, 32</sup>

In Austin, the number of building permits issued was sluggish for many years, with practically no ADU permits issued until 2007, when the number of permits jumped to 32. In November 2015, the City Council approved a series of reforms that accelerated the number of permits to a projected 387 in 2017. It is important to note that there are at least a couple of additional factors that may contribute to this increase in permits: a) Austin is not landlocked—its city limits are still expanding outward, and b) Austin also has some very large infill tracts inside its city limits with new home building, including ADUs.

## SURVEY METHODOLOGY

This study surveyed homeowners in Portland, Seattle, and Vancouver who had built ADUs (or recently purchased a property with a new ADU). After obtaining a list of addresses in each city that had received a permit to build an ADU in the recent past, we sent postcards inviting homeowners to respond to our online survey instrument to a random sample of addresses. We sent three rounds of postcards to each home (for more details, see Appendix B). Of a total of 1,837 addresses contacted, we obtained 414 responses, for a 23% response rate, including an estimated 37% in Seattle, 26% in Portland, and 11% in Vancouver.<sup>33</sup> Of those, 71% completed the full survey.<sup>34</sup>

The sampling methodology created some bias. Most importantly, our sample only includes those who have successfully navigated the ADU construction process, from design to permitting to construction and occupancy. Thus, we were not able to obtain the views of those who had tried to build an ADU but failed. As a result, the report findings likely underreport the extent of the barriers homeowners face. In addition, there was likely some response bias as the homeowners most interested in responding to the survey were those with either a positive or negative experience. Finally, because we sent the postcard to the main address, rather than the ADU address, we may have inadvertently undersampled homeowner respondents who now live in the ADU.

## ADUS IN THE SURVEY: WHAT DO THEY LOOK LIKE, HOW WERE THEY BUILT, AND HOW ARE THEY USED?

In this section, we report some of the basic characteristics of the ADUs from the three cities and how their owners use them. Given that we only surveyed properties that had been granted ADU permits, most (77%) of our survey respondents reported having completed their ADUs, while 20% still had an ADU under construction, and the remainder had not yet begun construction. The ADU development and construction process was fresh in the minds of most of our respondents, since 87% had completed their project within the last five years and fully 27% had completed or were planning to complete theirs in 2017. (See Figure B1 in the Appendix B for the full breakdown by year completed.)

### Physical characteristics

Most (67 percent) of the ADUs in our sample are detached from the main building on the property (Table 1). We believe this reflects the greater propensity for homeowners with detached ADUs to seek construction permits, given that their ADUs are more likely to attract attention from code enforcement. Among detached ADUs, by far the most common type is a freestanding cottage (56%), while most of the rest are freestanding garages (25%) or converted garages (18%). Among attached ADUs, by far the most common configuration is a converted basement (65%), perhaps because it tends to be comparatively inexpensive to execute.

ADU Type	Share
Detached	67%
Stand-alone detached unit	56%
Apartment above or beside a new freestanding garage	18%
Freestanding garage converted to an apartment	18%
Apartment above or beside an existing freestanding garage	7%
Other	33%
Attached	65%
Part or all of basement converted to an apartment	12%
Attached garage converted to an apartment	11%
Attached addition to house	9%
Rooms inside main part of house converted to an apartment	4%
Other	
<b>Total</b>	<b>100%</b>

Table 1. ADU types among survey respondents (n = 265)

*Permit design restrictions did not allow me to add 200 additional square feet with additional garage space below despite having lot size and total developable square foot allowance on property - this would have helped the economics tremendously.*  
—Vancouver homeowner

*I think laneway houses should only be considered where there is good public transit. My neighbourhood has that and so we don't have as many two and three car households.*  
—Vancouver homeowner

As is typical for ADUs in general, most of the units in our sample are quite small; the majority of the ADUs we sampled were one bedrooms (52%) and most of the rest efficiency units (29%). Only 19% have two or more bedrooms. Very few of the 244 respondents, 5%, reported having more than one bathroom. While units in the sample ranged from as small as 220 to as large as 1,575 square feet, for the most part they are clustered between those extremes, with an average reported size of 631 square feet and a standard deviation of 237 square feet. Almost all, or 97%, of the respondents reported that their units adhered to the full definition of an ADU by including kitchens.

Most ADUs in the sample include at least some off-street parking spaces: 24% have one, 34% have two, and 17% have three or more. Only 12% of ADUs report including no off-street parking. Given the small sizes (detailed below) of ADU occupant households, these results suggest that it is unlikely that the recent wave of ADU construction in the three cities is materially contributing to on-street parking congestion.

### Cost characteristics

The average ADU in our sample cost its owner approximately \$156,000 to build, albeit with a considerable standard deviation of approximately \$120,000.<sup>35</sup> This total cost figure varies considerably by city, with almost double the cost per square foot in Vancouver as in Portland, and Seattle in-between (Figure 5). These costs are comparable to the square foot costs for multifamily construction.<sup>36</sup> However, it should be noted that ADU costs do not generally include land costs, owner profit, or underground parking structures. They also have much lower carrying costs because the duration of construction is so much shorter.

Construction labor (33%) and materials (34%), which vary little by city, are the two biggest cost components of the average ADU project (Table 2), shares that are not terribly dissimilar from commercial-scale real estate developments. Architecture and engineering are a little on the high side at about 8%, though this is not surprising given that ADUs are small projects. City permits account for about 8%, and utility connections about 5% (slightly less in Vancouver). Thirteen percent of costs fall into the “other” category, likely due to variations in how respondents interpreted the various categories. On the whole, these figures suggest that the opportunity for cities to reduce costs is probably quite limited beyond further relaxing land use restrictions that inhibit certain efficient types of construction, such as taller ADUs. Permit and utility connection waivers might help on the margins, but according to our figures would not yield a radical reduction in costs in the average case.

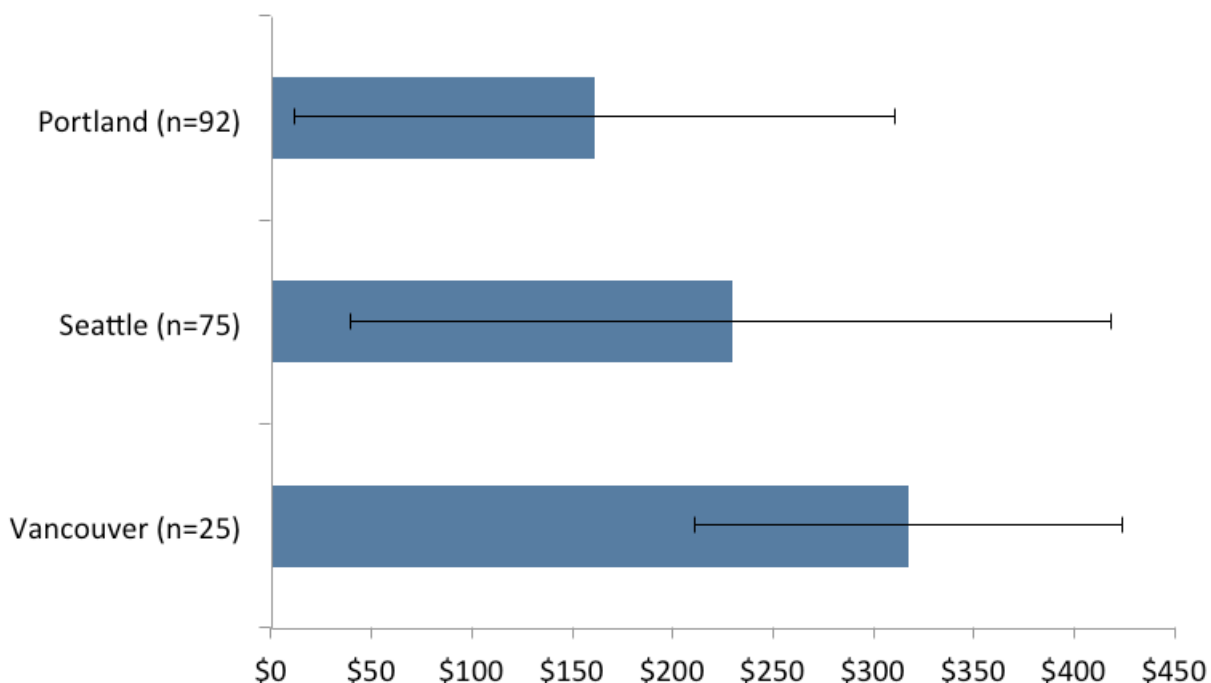

Figure 5. Reported Average ADU Project Cost Per Square Foot.  
 Note: error bars indicate one standard deviation above and below mean.

## Development team composition

Respondents (n=203) reported a variety of project delivery mechanisms to get their ADUs constructed. A design-build contractor was used in 25% of cases, while a traditional architect-contractor team was more common (40%). In 16% of cases, only a contractor (not doing design work) was involved in the project—presumably stock plans were used in these circumstances. These results suggest that homeowners are using a variety of teams to meet their goals, which could include simplicity (design-build), thoroughness (architect-contractor), and desire to economize on design costs (contractor only), depending on homeowners' individual preferences.

*This ADU was the first one for the builder so it was a learning process for all of us in various stages of ADU journey. (builder, site contractor, main home owners, and myself (a family member living in ADU)).*  
—Seattle homeowner

## Current or intended use of the ADU

A majority (51%) of our respondents reported that their ADUs are used as a current or intended primary residence, with a further 9% reporting they are used as extra space for main house residents (Figure 6). Thus 60% of ADUs are or will be used for the purposes of permanent housing, as compared to 12% for short term rentals. Several respondents commented that the planned use of the ADU for rental income made it possible for them to purchase the entire property. Our data therefore do not support the argument, sometimes brought up during public debates, that increased ADU production will not contribute to long-term housing for local residents because they will mostly be used for tourist rentals.

*"The cost of housing in Vancouver is astronomical. Most of the people that I know who have built laneway houses have done so to allow family members to have a place to live in the neighbourhood where they grew up."*  
—Vancouver homeowner

Cost component share	Average share of project budget
Construction labor	33%
Construction materials	34%
Architecture & engineering	8%
City permits	8%
Utility connections	5%
All others	13%
<b>Total</b>	<b>100%</b>

Table 2. Components of Total ADU Project Cost (n=171)  
Note: Actual total of these reported components differs slightly from 100% due to rounding.

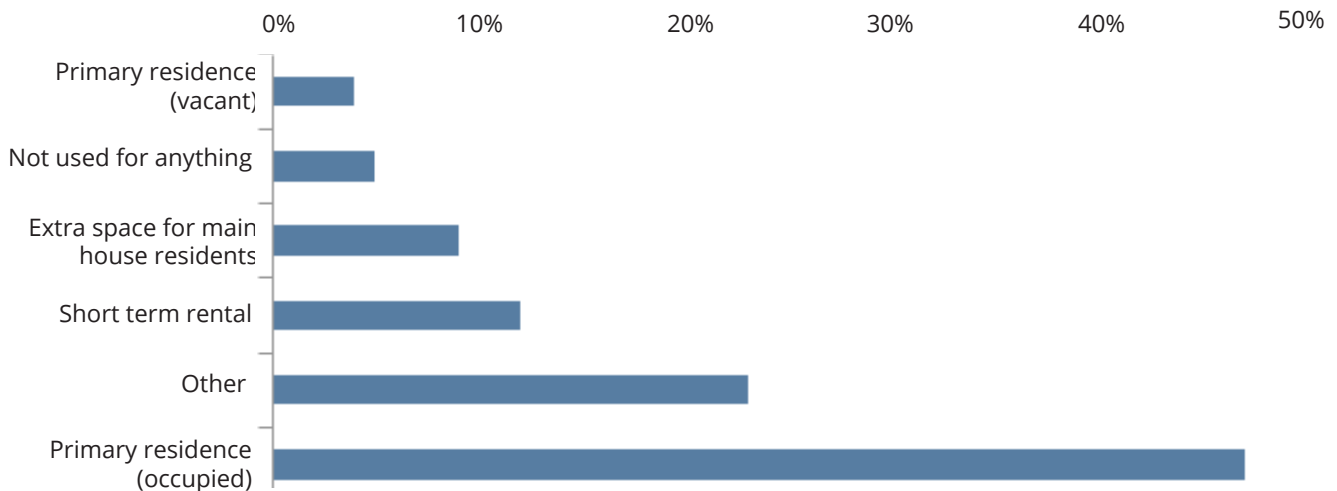
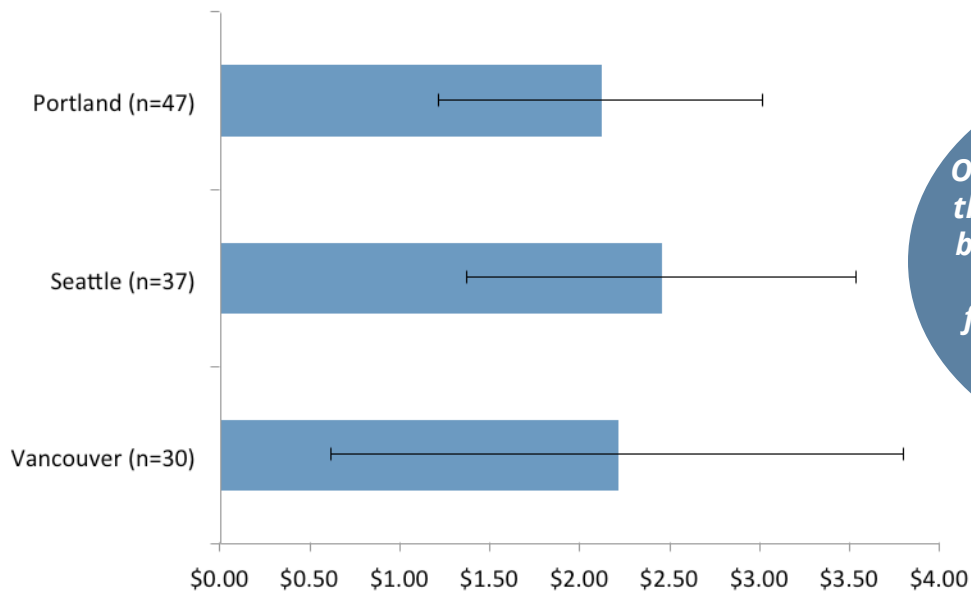

Figure 6. Current use of ADU (n=255).

## Rental characteristics

The average ADU in our survey that was rented to a tenant garnered \$1,298 in monthly rent, with a considerable standard deviation of \$632. Surprisingly, the per-square foot rents do not differ significantly across the three cities (Figure 7). As is well-known from previous studies of ADUs, most ADU occupant households are small, consisting of either one person (57%) or two people (36%). Only 7% of cases have a different household composition.



*Overall we are very happy that the city of Seattle allows ADUs both for financial reasons and for the fact that an elderly family member is able to live nearby.*  
—Seattle homeowner

Figure 7. Average Reported Monthly Rent, \$/square foot (leased ADUs).  
Note: error bars indicate one standard deviation above and below mean.

In instances where there is someone living in the ADU, in a plurality of cases (46%) the ADU is rented by someone with an arms'-length relationship to the homeowner. Most of the remainder of cases consist of tenants that either receive or might be expected to receive favorable treatment from the landlord because of their relationship: a friend or family member staying for free (17%) or a friend or family member paying rent (12%).<sup>37</sup>

The majority of ADUs rent for below market rates whether rented at arm's length or not, and thus may be considered a form of affordable housing. Overall, 58% of homeowners report renting below the market rate, with only about 40% of these ADUs occupied by family or friends.

Homeowners with ADUs rented to tenants reported increasing the rent only once every 24 months or less often (or never) in 30% of cases, while 40% reported increasing rent every 7 to 12 months. Thus, we see that depending on individual circumstances and specific landlords, in a substantial number of cases renting an ADU can be a bargain over time from the tenant's point of view.

*We needed a housing option for my mother who is 68 now and in good health. Building an ADU was by far the least expensive option for us to own a dwelling for her. In addition, we've been surprised about the added benefits and flexibility the ADU has added.*  
—Portland homeowner

## CHALLENGES AND OPPORTUNITIES

In this section we report on results from the survey that shed light on challenges and opportunities in ADU development.

### Motivation for building ADUs

By far the two most common reasons respondents cited for deciding to build ADUs are extra income from a long-term rental (38%) and creating living space for a household member or helper (28%). Both short-term rentals and the desire for flexible future were cited at 11% apiece.<sup>38</sup> All other reasons add up to only 12%. Collectively, these results suggest that homeowners have a variety of motivations and that a substantial minority enter into the ADU development process with the expectation of the use of their ADUs changing over time. This suggests to us that public sector efforts to micromanage the uses in ADUs may be counterproductive for the goal of maximizing production.

The top three factors cited by respondents that led them to “pull the trigger” on initiating an ADU project (206 top three responses drawn from n=86 separate respondents) were, in descending order, easing of land use rules (42%), obtaining enough money to begin (19%), and learning about ADUs through an educational website, event, or tour (15%) (Figure 8). Among those who were asked a follow-up question after citing easing of land use rules as a factor (87 top three responses from n=42 separate respondents), by far the two most consequential were minimum lot size (n=37%) and allowable floor area (n=29%). Notably, it was in Seattle, which has yet to enact significant zoning reforms, that many respondents indicated a need to ease zoning rules.

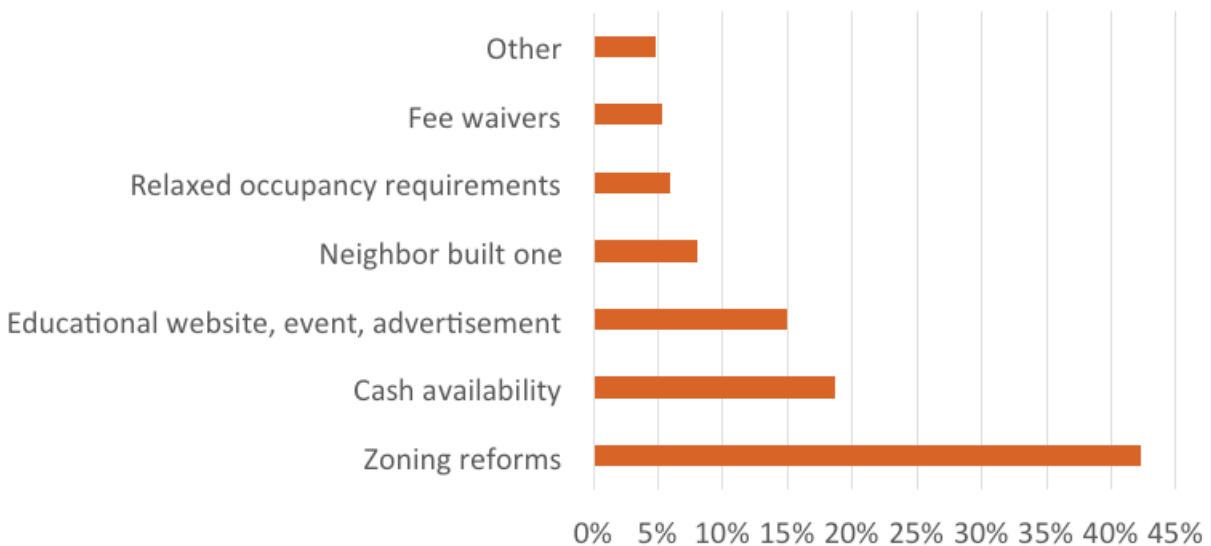

Figure 8. Most important factors leading to the decision to build an ADU.

These results suggest that, as suspected, the easing of some land use restrictions on ADUs in the three cities have done a great deal to motivate ADU production. Further easing could help still more, particularly with respect to minimum lot size and maximum ADU size. At least some of those concerned about obtaining enough money to begin an ADU project could be encouraged through innovative financing products (discussed further below). Finally, the fact that websites, events, and tours promoting ADUs were almost tied for second as a

*We invited the neighbors to tour our ADU when finished.*  
 —Seattle homeowner

triggering factor for the ADU “build” decision suggests that these efforts have a high “bang for buck” ratio: they cost relatively little but can have a surprisingly large impact. Indeed, a prominent ADU builder and activist in Portland told us that promotional activities have been instrumental in accelerating ADU production in that city. Something as basic as informing members of the public that ADUs exist and that they are a viable option for many homeowners, it would seem, is surprisingly important.

### Biggest challenges faced by homeowners who successfully built an ADU

Of all the mentions of challenges faced by survey respondents in developing their ADU (i.e. those challenges that appeared in the top 3), by far the most common were obtaining a loan (34% of mentions) and paying for the cost of construction (18%). Almost 5% of respondents were turned down for loan finance on their first attempt, though most were able to overcome this problem by turning to another financial institution or product. Though opportunities to reduce cost of construction through public policy may be limited, these results confirm that interventions in the lending market for ADUs may have a significant impact on increasing ADU production.

*I LOVE my ADU. All of my neighbors love it, too. It is very cute and fits right into its setting behind our 1916 house. I was the 83 person in Seattle to get the permit to build a Backyard Cottage . The Seattle guide to building a backyard cottage is a very good resource.*  
 —Seattle homeowner

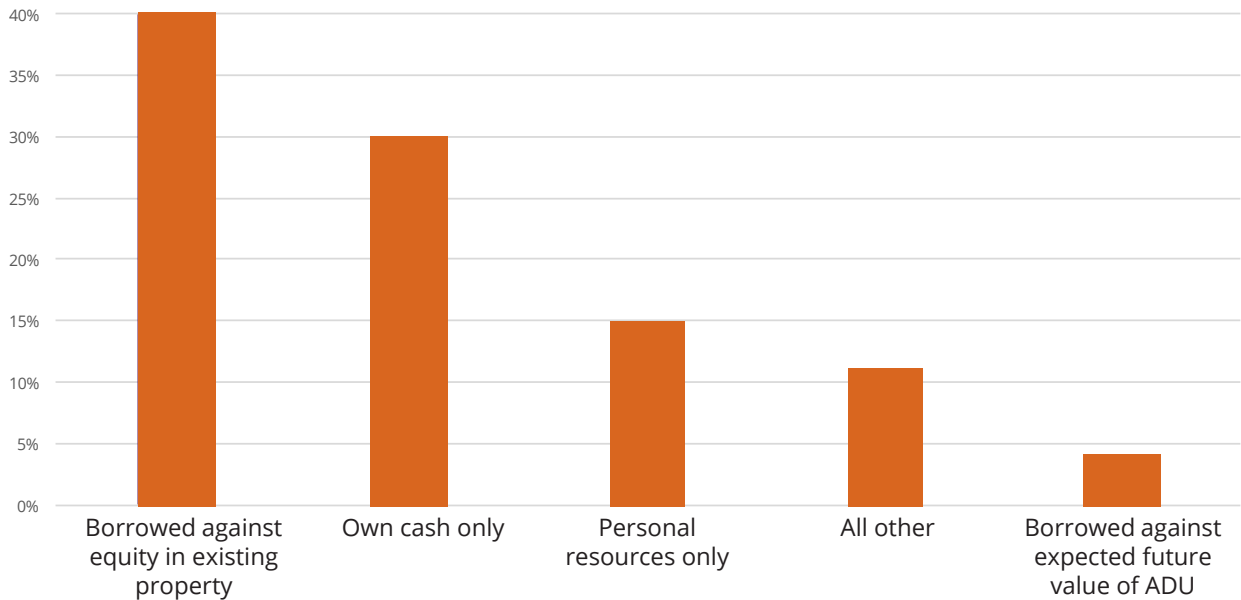

Figure 9. Source of Financing for ADU Development (n=210).

Note: Categories are mutually exclusive. "Borrowed against equity in existing property" and "Borrowed against expected future value of ADU" are sources of financing that in many cases were combined with other sources.

*It has been 15 years since we completed our ADU. I am disappointed in how it has affected the appraised value of our property. Appraisers can't find similar properties for comps and they do not consider the added value of the income in valuing the property.*  
 —Portland homeowner

## Financing source

To finance their ADU project, 30% of respondents used only their own cash. An additional 15% drew entirely on other personal resources such as credit cards (Figure 9). Among the remainder, 40% of respondents reported borrowing against the existing equity in their property in some way, such as via a Home Equity Line of Credit (HELOC) or a cash-out refinance. A paltry 4% reported borrowing, at least in part, against the future expected value of the unbuilt ADU to help finance its construction.

These results are, to us, a strong indication of a market failure. The low development costs and comparatively high rents obtained by ADUs ought to make it possible, in many cases, for homeowners to borrow against the future value of an unbuilt ADU, but this does not appear to be happening often.

Of the lending on ADU projects that does occur, locally-focused lenders seem to be disproportionately important. Of the 91 respondents who reported getting a loan of some type and who indicated what type of institution made the loan, 60% reported borrowing either from a credit union or a local or regional bank. Only 34% reported receiving a loan from a national bank. This suggests that efforts to encourage or create innovative financing products to ease ADU financing might most productively focus on partnerships with locally-focused lending institutions that already understand the local real estate market in general and ADUs in particular. Indeed, our interviewees suggested that some local and regional lenders, such as Vancity in Vancouver and Umpqua Bank in Portland, have already been instrumental in innovating ADU lending programs and practices.

**Financing is critical. With changing bank requirements for income, it seems anybody without a high-paying job is out of the running for an ADU. For example [t]he soon to retire or retired couple with a house almost paid off would not qualify for a refinance.**

**Neighbors! Many were supportive but a few objected to the city and made up spurious complaints which the city had to come out and inspect, though we were never cited as in violation of anything.**  
—Seattle homeowner

**On the whole, I can see the value in work being inspected, but the permitting process isn't something I'd ever hope to go through again. Next time I build a small house it'll be on wheels.**  
—Seattle homeowner

**Working with the City of Portland was a MAJOR pain. First acquiring information, then going through the multitude of steps. Information seemed to change as the project went along. It was SUPER frustrating.**  
—Portland homeowner



## Permit problems and project duration

Only 19% of respondents (n=209) reported being turned down for a permit. By far the largest number of those—almost half—overcame the setback by making design changes. On the other hand, 70% of respondents (n=200) experienced unanticipated events that led to delays and cost increases to the project. The most common issues (n=139 reported issues from 133 separate responses) are issues with the permitting process (36%), poor professional assistance (22%), and existing infrastructural problems (16%). From this we surmise that most homeowners enter into the ADU permitting process with a high probability of ultimate success—with the possible exception of Seattle, where respondents detailed having to overcome a variety of challenges with permitting. However, anything that could make the permitting process more transparent and predictable would likely be helpful. Such efforts could arise either from within local government, or via technical assistance provided by outside entities, such as architectural design and project management services provided at low cost by students under faculty supervision at local universities.

Even with a large majority of respondents reporting delays, ADU projects are still strikingly fast when compared to other types of real estate development. multifamily development projects, for example, routinely take three or more years from conception to opening. The equivalent time span for our respondents for their ADU projects (n=197) was 18 months or less in 83% of cases, and six months or less in just under a quarter. These “lean” schedules are driven by short construction phases, which take less than a year in 83% of cases and less than six months in 45%. Efforts to reduce these time periods might, therefore, achieve comparably little. However, better predictability in the development and permitting process would probably be quite helpful in avoiding delays. After all, delays may not faze a professional developer but are often aggravating and discouraging for everyday homeowners seeking to add an ADU to their properties.

*I have discovered that our local building codes and inspection regime add significant cost without, in many cases, adding significant value in terms of function or safety.  
—Seattle homeowner*

## Desired resources for aiding ADU development

When asked what resources they wished they had had while developing their ADUs, respondents (n=157) gave a variety of answers. The following responses (aside from “not applicable”) accounted for at least 60% of the total: professionals with ADU knowledge (24%); an easy-to-understand and comprehensive guide through the entire process (20%); better assistance from city government (15%); and better financing options (10%). The first desired resource, professionals with ADU knowledge, ought to begin to resolve as ADU production spreads and increases. Easy-to-understand and comprehensive guides through the entire process would be relatively easy and comparatively cheap for cities to produce, requiring perhaps several thousand dollars. As discussed earlier, intervening in the market for financing ADUs would likely be highly productive, but also would require a great deal of effort and lie at least partly out of cities’ purview. Thus, among these responses, the city-produced guide to the ADU development process stands out as truly “low hanging fruit” for municipalities interested in boosting their ADU production.

## CONCLUSION AND POLICY IMPLICATIONS

Despite the push for ADU reforms, prior to this study little was known about the extent to which they succeed at jumpstarting the ADU market. This survey of homeowners describes the unique role that ADUs play in hot housing markets, and how zoning reforms in particular have spurred construction. ADU owners in Portland, Seattle, and Vancouver value their ADUs as small and flexible spaces that can be built relatively quickly. Though built for a variety of purposes, the majority are actually affordable housing.

Three factors are key to the success of ADU implementation. First, in cities that have reformed their zoning regulations (particularly minimum lot size and floor area) production has jumped. Also important are minimizing design review and easing owner occupancy requirements. In general, homeowners appear to greatly value the ability to use an ADU flexibly—an ADU could be rented to a stranger today, used to house an aging parent tomorrow, and rented nightly to out-of-town visitors sometime later. For this reason, local governments need to resist the inevitable pressures to unduly restrict not only how they are built, but how they are used after they are built. If homeowners lack the confidence that a new ADU can be used in the way they see fit at the time they need it, fewer of them will commit the considerable financial and logistical resources to build one.

Second, waiving fees such as permit or utility connection fees can spur homeowners to build—but aside from such waivers it will be difficult to reduce construction costs for ADUs. ADUs are already likely the cheapest way to add housing units to a built-up neighborhood. This is not only because they are small, but also because they use a cheap, efficient form of construction, they can be built quickly, and, of course, because their land costs are zero.

Finally, cities that take steps to educate homeowners (for instance, via ADU manuals and prototype plans), as well as providing technical assistance, will likely see a payoff for relatively minimal cost and effort. A big part of winning hearts and minds in the battle for more ADUs is simply raising awareness. Local governments can play a catalytic role in publicizing the possibility for homeowners. Ideally, civil society groups will then pick up the mantle in promoting ADUs, advocating for better policies, and disseminating information that helps homeowners otherwise intimidated by the permitting, design, and construction processes. Along the way, the dominant narrative about ADUs can shift from their burdens and impacts to their benefits and even cultural cachet. We learned that this is exactly what has occurred in Portland over the past decade.

To date, no city has developed a comprehensive and fully effective approach to assisting homeowners with financing ADUs. As a result, aside from homebuilders, only the most affluent homeowners, who can tap into savings, are building ADUs. The robust growth in ADU construction seen in Portland and Vancouver and, to a lesser extent, Seattle, can accelerate further, reach a wider constituency, and spread to other large cities once new lending practices emerge that allow homeowners to borrow against the future value of the asset they seek to build on their own properties. These innovative financing models stand the best chance of success if local governments collaborate with lending institutions, particularly locally-focused ones such as credit unions, to bring them into being. If and when this “Holy Grail” of lending is achieved, the ADU market will truly be jumpstarted.

## NOTES

1. In certain densely-built urban regions, such as Los Angeles, opportunities may exist to incrementally add ADU-like units to residential properties that already include more than one home, such as duplexes or triplexes. However, in the vast majority of the metropolitan areas of the United States, including in the Pacific Northwest cities that we study, most urban territory is zoned for single-family housing only. This means that most opportunities for adding ADUs will come from single-family lots, and that is what we focus on in this study.
2. Jonathan Woetzel, Jan Mischke, Shannon Peloquin, and Daniel Weisfield, "A Tool Kit to Close California's Housing Gap: 3.5 Million Homes by 2025," McKinsey Global Institute, 2016 (October); Jake Wegmann and Karen Chapple, "Hidden Density in Single-Family Neighborhoods: Backyard Cottages as an Equitable Smart Growth Strategy," *Journal of Urbanism: International Research on Placemaking and Urban Sustainability*, vol., 7 (2014), 307–329.
3. For a list of ordinances around the country, see <https://accessorydwellings.org/adu-regulations-by-city/>
4. For instance, in the year after Berkeley passed its ADU reforms, it received about a dozen applications for ADUs, up from about 5 per year.
5. Maurizio Antoninetti, 'The Difficult History of Ancillary Units: The Obstacles and Potential Opportunities to Increase the Heterogeneity of Neighborhoods and the Flexibility of Households in the United States', *Journal of Housing For the Elderly*, 22.4 (2008), 348–75 <<https://doi.org/10.1080/02763890802458320>>.
6. Margaret F. Brinig and Nicole Stelle Garnett, *A Room of One's Own? Accessory Dwelling Unit Reforms and Local Parochialism* (Rochester, NY: Social Science Research Network, 29 May 2013) <<http://papers.ssrn.com/abstract=2271781>> [accessed 17 September 2016].
7. Karen Chapple, Jake Wegmann, Alison Nemirow, and Colin Dentel-Post, "Yes in My Backyard: Mobilizing the Market for Secondary Units," 2012, Center for Community Innovation (UC Berkeley), <http://communityinnovation.berkeley.edu/reports/secondary-units.pdf>.
8. *The Alley Flat Initiative*, Working Paper Series (University of Texas Center of Sustainable Development, July 2008) <<http://251.sustainablesources.com/alleyflat2016demo/af-content/uploads/2016/02/AFI-SOA-2008-report.pdf>>.
9. Rodney L. Cobb and Scott Dvorak, "Accessory Dwelling Units: Model State Act and Local Ordinance," *AARP*, 2000 <[http://www.aarp.org/home-garden/housing/info-2000/accessory\\_dwelling\\_units\\_\\_model\\_state\\_act\\_and\\_local\\_ordinance.html](http://www.aarp.org/home-garden/housing/info-2000/accessory_dwelling_units__model_state_act_and_local_ordinance.html)> [accessed 18 September 2016].
10. Jake Wegmann, "Financing Ancillary Apartments on Residential Properties: Challenges and Solutions," August 2015, Institute for Governmental Studies (UC Berkeley), [https://igs.berkeley.edu/sites/default/files/2015\\_housing\\_research\\_brief\\_8-25-15.pdf](https://igs.berkeley.edu/sites/default/files/2015_housing_research_brief_8-25-15.pdf). Gerald E. Buker, "A Study of Backyard Cottage Policy in Seattle, Washington: Existing Conditions Study, Capacity Analysis, and Survey in Conjunction with Seattle's Department of Planning and Development" (unpublished Master's thesis, University of Washington, 2015) <<http://search.proquest.com/docview/1730399825/abstract/F0F707FF859E4EBAPQ/1>> [accessed 23 September 2016].
11. Martin John Brown and Jordan Palmeri, *Accessory Dwelling Units in Portland, Oregon: Evaluation and Interpretation of a Survey of ADU Owners* (State of Oregon, Department of Environmental Quality, 1 June 2014), pp. 1–47 <<https://accessorydwellings.files.wordpress.com/2014/06/adusurveyinterpret.pdf>> [accessed 17 September 2016].
12. *The Alley Flat Initiative*, Working Paper Series (University of Texas Center of Sustainable Development, July 2008) <<http://251.sustainablesources.com/alleyflat2016demo/af-content/uploads/2016/02/AFI-SOA-2008-report.pdf>>.
13. Martin John Brown and Taylor Watkins, 'Understanding and Appraising Properties with Accessory Dwelling Units', *Appraisal Journal*, 80.4 (2012), 297.

14. Brown and Palmeri, op. cit.
15. Alison Steele, *2014-Innovation-and-Practice-in-House-Design-Research-Grant-3-8-15.pdf*, 2014 <<http://251.sustainablesources.com/alleyflat2016demo/af-content/uploads/2016/02/2014-Innovation-and-Practice-in-House-Design-Research-Grant-3-8-15.pdf>> [accessed 4 November 2016].
16. Canada Mortgage and Housing Corporation, *Accessory Apartments: Characteristics, Issues, Opportunities* (Ottawa, Canada: CMHC, 1990).
17. Canada Mortgage and Housing Corporation, "Research Highlight: Literature Review and Case Studies of Local Jurisdictions that Permit Secondary Suites," (Ottawa, Canada: CMHC, 2015).
18. Ibid.
19. Steele, op. cit.
20. Chapple et al. 2012, op. cit.
21. See <https://www.habitatmontereybay.com/own-a-home> and <http://www.santacruzsentinel.com/article/NE/20160210/NEWS/160219960>
22. Jake Wegmann, and Alison Nemirow, *Secondary units and urban infill: a literature review*, Working Paper (Berkeley, CA: Institute of Urban and Regional Development, 2011).
23. Home Builders Association of Metropolitan Portland, System Development Charges. Accessed April 6, 2017 at <http://hbapdx.org/advocacy/system-development-charges/>
24. Notably, the website <http://www.accessorydwellings.org/>, which provides a central repository of information to navigate the ADU production process, was created and is still maintained by volunteers in Portland.
25. Brown and Palmieri, op. cit.
26. These are under consideration but not yet approved.
27. "The Role of Secondary Suites: Rental Housing Strategy Study 4," December 2009, Social Developing-Housing Policy, Community Services Group, City of Vancouver, <http://vancouver.ca/docs/policy/housing-secondary-suites.pdf>.
28. Figures provided by Heather Burpee, City of Vancouver.
29. Portland ADU permit figures from "The Ascent of ADUs in Portland," February 27, 2017, [accessorydwellings.org](https://accessorydwellings.org) (URL <https://accessorydwellings.org/2017/02/27/the-ascension-of-adus-in-portland/>). Seattle and Vancouver ADU permit figures obtained from staff from each city. Note that Vancouver figures are likely an undercount as they only include laneway houses and infill homes (ADU-like units allowed on certain properties as part of a historic preservation strategy), and do not include secondary suites, for which annual issued permits totals are not maintained by the city. Overall Portland and Seattle building permit figures are from the Building Permits Survey of the US Census. Vancouver overall building permit figures are from BC (British Columbia) Stats.
30. Between 2011 and 2017, housing prices have increased by 42% in Salt Lake City, from \$193,758 to \$259,908, while in Austin, prices have increased by 56%, from \$198,950 to \$310,850 (in 2017 dollars), compared to a nationwide average increase of 25%. Sources: ZHVI All Homes (SFR, Condo, Co-op) Time Series (\$), <https://www.zillow.com/research/data/#median-home-value>
31. "Accessory Dwelling Units Amendment." Salt Lake City Planning Division. <http://www.slcgov.com/sites/default/files/documents/planning/2016/ADU%20Initiative.pdf>
32. Additionally, zoning changes will be necessary because ADUs are actually prohibited in most areas of the city. See "Growing SLC: A Five Year Housing Plan: 2017-2021." Salt Lake City Housing and Neighborhood Development. Draft February 2017. [http://www.slcdocs.com/hand/Housing\\_plan\\_short.pdf](http://www.slcdocs.com/hand/Housing_plan_short.pdf)
33. About 35% of respondents neglected to enter the survey ID that allowed us to identify their home city, making it challenging to determine response rate by city. We were not able to determine the distribution of these respondents, so in estimating the response rate, we assumed that the distribution of these respondents with unknown geographies was the same as those with known geographies.

34. Most (80%) of the incomplete surveys came from respondents with unknown geographies.
35. Because the economies of the US and Canada are so similar and intertwined, and because their respective currencies have at times been at parity, in this report we simply lump US and Canadian dollar figures together for simplicity and ease of comparison. See Ryan Macdonald, "Do Relative Canada/U.S. (United States) Prices Equate to the Exchange Rate?," January 2012, Statistics Canada, Economic Insights No. 003, Catalogue no. 11-626-X.
36. Source: RS Means, <http://learn.rsmeans.com/rsmeans/models>
37. Although the survey did not ask about situations in which the main house is rented and the ADU is occupied by the landlord, several respondents volunteered that this was their situation.
38. Several respondents noted in the comments that they rent via Airbnb, but did not select the short-term rental response option because they did not realize it was the same thing. Thus, the 12% figure may be a slight underestimate.

## APPENDIX A: ADU REGULATIONS

ADU Criteria across the Pacific Northwest

<b>ADU Criteria</b>	<b>Portland</b>	<b>Seattle</b>	<b>Vancouver</b>
Detached allowed?	Y	Y	Y
Attached allowed?	Y	Y	N/A
Both Allowed? (2 per lot?)	N	N	N
Minimum lot size (Sq. ft.) - Interior	N/A	Y	Y
Minimum lot size (Sq. ft.) - Corner	N/A	N/A	N/A
Setbacks	Y	Y	Y
Number parking spots required	N	1	N/A
Tandem parking allowed?	N/A	Y	N/A
Covered parking?	N/A	N/A	N/A
Parking waiver?	N/A	Y	N/A
Owner-occupancy requirement	N/A	Y	N/A
Maximum size Sq. ft. (detached)	Y	Y	Y
Maximum size Sq. ft. (attached)	Y	Y	N/A
Separate metering requirement?	N	N	N
Height limit	Y	Y	Y

Sources: Bureau of Development Services Program Guide: Accessory Dwelling Units; Portland Title 33, Planning and Zoning Chapter 33.205 Accessory Dwelling Units; Seattle Government Municipal Code; Removing Barriers to Backyard Cottages; Accessory Dwelling Unit (Mother-in-Law Apartment); City of Vancouver Land Use and Development Policies and Guidelines: Laneway House (LWH) Guidelines; City of Vancouver Bylaws: Zoning Section 2 Definitions; City of Vancouver Bylaws: Zoning Section 10 General Regulations; City of Vancouver Bylaws: Zoning Section II Additional Regulations.

## APPENDIX B: SURVEY METHODOLOGY

### Compiling addresses of ADUs

#### Portland

Portland did not have a complete list of addresses with ADUs. However, there is an online database of building permits issued as far back as 2000. This provided a substantial share of the city's total permitted ADUs as they were only legalized a few years earlier. (Our interviewees told us that permit issuances were far lower in the earliest years.) This database allowed us to select building permits issued for ADUs since 2000. We found 1,569 addresses with ADU permits.

#### Seattle

Seattle also did not have a complete list of addresses with ADUs. However, the city released a report about backyard cottages that has addresses of homes with backyard cottages that received permits from 2011 to 2014. In addition, the city has a similar online database to Portland's from which we were able to get building permits issued for any type of ADU from 2012 to November 2016. We put these samples together and removed the duplicate addresses. This led us to have a total sample frame of 426 addresses with ADUs from Seattle.

#### Vancouver

City staff from Vancouver sent us a list of all ADUs permitted between 2011 and 2015, separating them into a list of addresses for secondary suites (attached ADUs) and a list of addresses for laneway homes (detached ADUs). There were 1,371 laneway suites and 2,573 secondary suites. In Vancouver, laneway homes are given a separate address from the main house, rather than being called "unit b" or something similar, as was the case for ADUs in Portland and Seattle. We were able, however, to find the main house addresses for these secondary suites. Additionally, in Vancouver it is possible to have one of each type of ADU, laneway house and secondary suite, on the same residential property, so some addresses have both a laneway home and secondary suite. Thus, we created a list of 423 addresses with both a laneway home and secondary suite, 2,158 homes with only a secondary suite and 922 homes with only a laneway suite.

### Creating samples

After compiling the addresses for the cities, we had to create samples. Wanting to get a consistent number of results among the cities, we decided to send equally sized samples to each city. Our budget allowed us to send postcards to more addresses than we had for Seattle, so we decided to send postcards to every address we had for Seattle — 426 — and to then send an equal number of postcards to Vancouver and Portland. This allowed us to send 713 postcards to each of those two cities. Given the unique conditions of the data for each city, we were able to stratify our samples somewhat. Portland offered an interesting split of permitting in early 2010 when the city decided to waive many of the development fees. Thus, we took two samples of addresses: i) up to and including March 2010 and ii) those from April 2010 and later. There were only 344 total addresses from the earlier time period, which is less than the 713 postcards we could send, so we sent postcards to all of those addresses and sent slightly more, 369, to the addresses that got permits in April 2010 and later. Finally, we did a similar split for Vancouver, sending about a third of the 713 postcards each to the three groups of addresses we made. So, we sent 238 postcards to addresses with only a secondary suite, 238 postcards to addresses with only a laneway house, and 237 postcards to addresses with both.

For the sake of simplicity in keeping track of these addresses, we issued each address a four-digit ID number with the first digit corresponding to the city. Survey respondents were asked to enter their code when taking the survey. This allowed us to remove the addresses whose occupants had already responded to the online survey from the second and third mailings of postcards.

## Sending the postcards

With the samples in place, we sent out the postcards in three rounds: from December 2016 to January 2017 in Portland and Seattle, and January to February 2017 in Vancouver. Postcards were addressed to the ADU Homeowner.

## Returned postcards

Approximately 8% (148) of the postcards were undeliverable. These were evenly distributed between Portland and Seattle. Just one postcard was returned from Vancouver, but this low total may be due to policies that limit returns across international borders. In Seattle, 1/3 were returned and most of the remainder because there was “no such number.” In Portland, 20% were vacant, almost 30% were “no such number,” and the remainder were “undeliverable as addressed.” These delivery problems may have occurred at addresses where the permitted ADUs had never actually been built. To calculate the response rate, we subtracted the returned postcards from the denominator.

## Responses by year completed

Figure B1. Number of Responses by Year ADU Completed, All Three Cities (n=215).

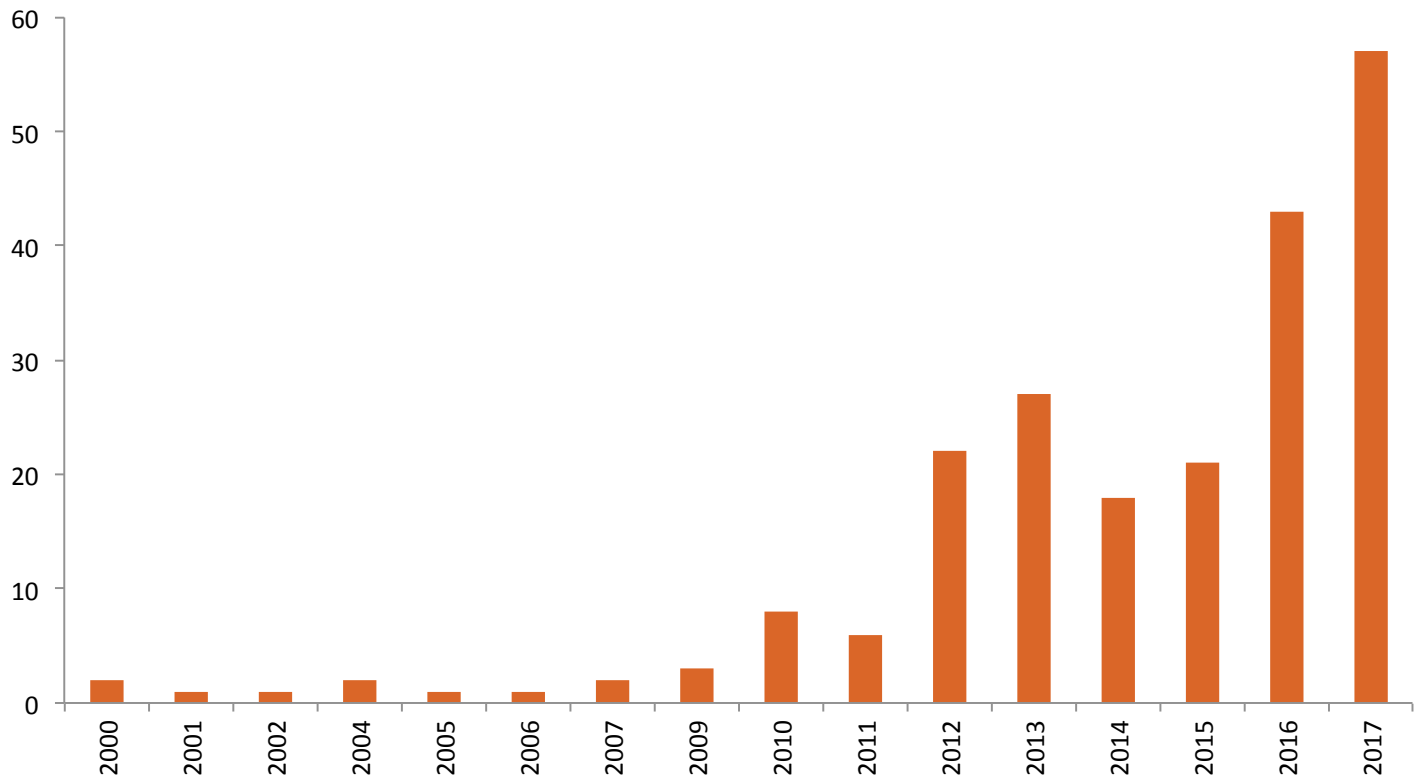



# The ABCs of ADUs

A guide to  
**Accessory Dwelling Units**  
and how they expand housing options  
for people of all ages



BASEMENT ADU



DETACHED ADU



ATTACHED ADU



SECOND-STORY ADU



GARAGE-CONVERSION ADU



Real Possibilities



**Websites:** [AARP.org](http://AARP.org) and [AARP.org/Livable](http://AARP.org/Livable)  
**Email:** [Livable@AARP.org](mailto:Livable@AARP.org)  
**Facebook:** /AARPLivableCommunities  
**Twitter:** @AARPLivable  
**Free Newsletter:** [AARP.org/Livable-Subscribe](http://AARP.org/Livable-Subscribe)

**AARP** is the nation's largest nonprofit, nonpartisan organization dedicated to empowering people 50 or older to choose how they live as they age. With nearly 38 million members and offices in every state, the District of Columbia, Puerto Rico and the U.S. Virgin Islands, AARP strengthens communities and advocates for what matters most to families: health security, financial stability and personal fulfillment. The AARP Livable Communities initiative works nationwide to support the efforts by neighborhoods, towns, cities, counties, rural areas and entire states to be livable for people of all ages.



**Website:** [OrangeSplot.net](http://OrangeSplot.net)  
**Email:** [eli@OrangeSplot.net](mailto:eli@OrangeSplot.net)

**Orange Splot LLC** is a development, general contracting and consulting company with a mission to pioneer new models of community-oriented, affordable green housing developments. Orange Splot projects have been featured in the *New York Times*, *Sunset Magazine* and on NBC's *Today* show. (The detached ADUs on page 3 and the back cover are by Orange Splot.) Company founder Eli Spevak has managed the financing and construction of more than 250 units of affordable housing, was awarded a Loeb Fellowship by the Harvard University Graduate School of Design, cofounded the website [AccessoryDwellings.org](http://AccessoryDwellings.org) and serves as a vice chair of Portland, Oregon's Planning and Sustainability Commission.

## The ABCs of ADUs

**A guide to Accessory Dwelling Units and how they expand housing options for people of all ages**

**WRITTEN AND EDITED BY:** Eli Spevak, Orange Splot LLC | Melissa Stanton, AARP Livable Communities

**ART DIRECTOR:** Mimi Park, Design Park, Inc.

**COPY EDITOR:** Don Armstrong | **ART PRODUCTION:** Steve Walkowiak

### PROJECT ADVISERS AND REVIEWERS:

Danielle Arigoni, Director, AARP Livable Communities

Karen Chapple, Professor, University of California, Berkeley

Lina Menard, Founder, Niche Consulting

Heather Peters, Senior Housing and Community Development Policy Analyst, San Mateo County, California

Kol Peterson, Cofounder, [AccessoryDwellings.org](http://AccessoryDwellings.org) | Caravan: The Tiny House Hotel | ADU Tour: Portland, Oregon

Denise Pinkston, Partner, TMG Partners

Harriet Tregoning, past Principal Deputy Assistant Secretary, U.S. Housing and Urban Development

Jake Wegmann, Assistant Professor, University of Texas at Austin

### COVER IMAGE CREDITS (clockwise from top left)

**Front:** Communitecture: Architecture, Planning, Design | Alex Hayden | [AccessoryDwellings.org](http://AccessoryDwellings.org) | [AccessoryDwellings.org](http://AccessoryDwellings.org) | Melissa Stanton, AARP

**Back:** Kol Peterson, [BuildingAnADU.com](http://BuildingAnADU.com) | Eli Spevak, Orange Splot LLC | Schuyler Smith, Polyphon Architecture & Design, LLC

**A NOTE TO READERS:** Many of the photographs and project examples in this publication are from Portland, Oregon, one of the first municipalities in the nation to encourage the creation of accessory dwelling units.

Visit [AARP.org/ADU](http://AARP.org/ADU) to download or order this free guide and find more resources about accessory dwelling units.

# Welcome! Come On In

**AARP surveys consistently show that the vast majority of people age 50 or over want to remain in their homes and communities as they age rather than relocate**

We know from surveys by AARP and others that a majority of Americans prefer to live in walkable neighborhoods that offer a mix of housing and transportation options and are close to jobs, schools, shopping, entertainment and parks.

These preferences — coupled with the rapid aging of the United States’ population overall and decrease in households with children — will continue to boost the demand for smaller homes in more compact neighborhoods.

**As small houses or apartments that exist on the same property lot as a single-family residence, accessory dwelling units — or ADUs — play a major role in serving a national housing need.**

This traditional home type is reemerging as an affordable and flexible housing option that meets the needs of older adults and young families alike.

In fact, in the 2018 AARP Home and Community Preferences Survey, people age 50-plus who would consider creating an ADU said they’d do so in order to:

- provide a home for a loved one in need of care (84%)
- provide housing for relatives or friends (83%)
- feel safer by having someone living nearby (64%)
- have a space for guests (69%)
- increase the value of their home (67%)
- create a place for a caregiver to stay (60%)
- earn extra income from renting to a tenant (53%)

Since ADUs make use of the existing infrastructure and housing stock, they’re also environmentally friendly and respectful of a neighborhood’s pace and style. An increasing number of towns, cities, counties and even states have been adapting their zoning or housing laws to make it easier for homeowners to create ADUs.

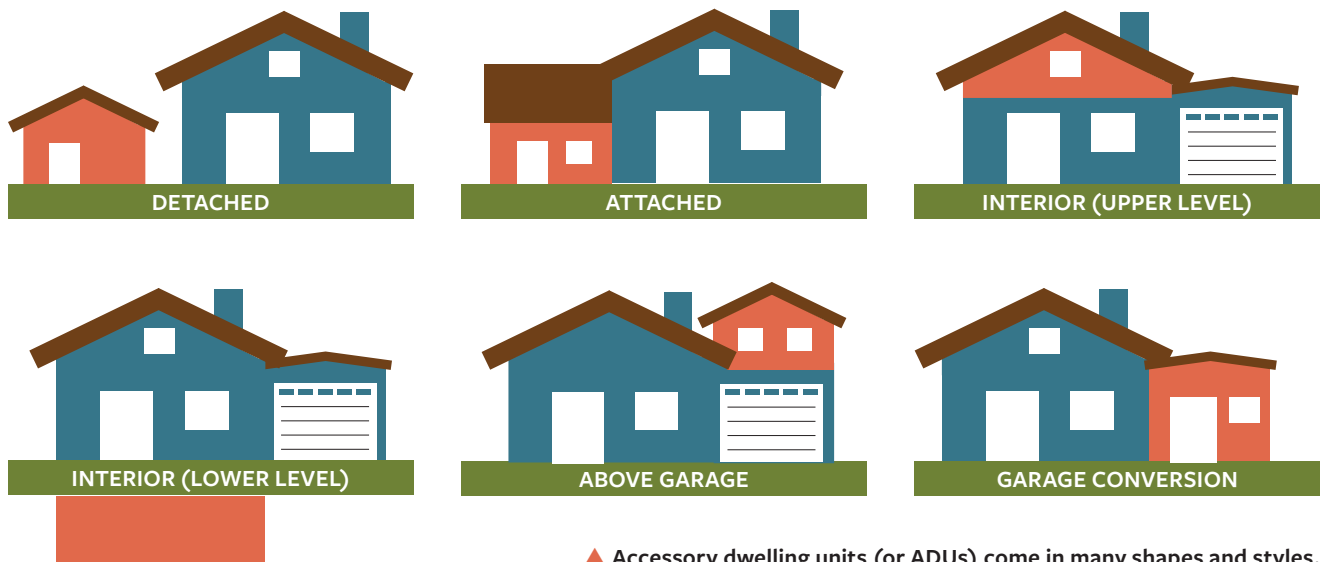

▲ Accessory dwelling units (or ADUs) come in many shapes and styles.

**The ABCs of ADUs** is a primer for elected officials, policymakers, local leaders, homeowners, consumers and others to learn what accessory dwelling units are and how and why they are built. The guide also suggests best practices for how towns, cities, counties and states can include ADUs in their mix of housing options.

# ADUs Come in Many Shapes and Styles

**ADUs are a family-friendly, community-creating type of housing the nation needs more of**

Although many people have never heard the term, accessory dwelling units have been around for centuries (see page 6) and are identified by many different names. To be clear about what’s being discussed:

- An ADU is a small residence that shares a single-family lot with a larger, primary dwelling
- As an independent living space, an ADU is self-contained, with its own kitchen or kitchenette, bathroom and sleeping area
- An ADU can be located within, attached to or detached from the main residence
- An ADU can be converted from an existing structure (such as a garage) or built anew
- ADUs can be found in cities, in suburbs and in rural areas, yet are often invisible from view because they’re positioned behind or are indistinct from the main house
- Because ADUs are built on single-family lots as a secondary dwelling, they typically cannot be partitioned off to be sold separately
- An ADU can provide rental income to homeowners and an affordable way for renters to live in single-family neighborhoods
- An ADU can enable family members to live on the same property while having their own living spaces — or provide housing for a hired caregiver
- Unlike tiny houses (see page 17), ADUs are compact but not teeny, so they’re a more practical option for individuals, couples and families seeking small, affordable housing
- For homeowners looking to downsize, an ADU can be a more appealing option than moving into an apartment or, if older, an age-restricted community
- ADUs can help older residents remain in their community and “age in place”



CREATIVE COMMONS

▲ Accessory dwelling units show up in neighborhoods throughout the country — and even in pop culture. One example: In the sitcom *Happy Days*, Fonzie (right) rented an above-garage ADU from the Cunningham family in 1950s-era Milwaukee, Wisconsin.

## ADUs are also known as ...

Although most local governments, zoning codes and planners in the United States use the term *accessory dwelling unit* or *ADU*, these small homes and apartments are known by dozens of other names. The different terms conjure up different images. (Who wouldn’t rather live in a “carriage house” than in an accessory or “ancillary” unit?) Even if you’ve never heard of accessory dwelling units or ADUs, you have likely heard of — and perhaps know the locations of — some of the home types noted at right.



▲ Renting out this 350-square-foot garage-conversion ADU in Portland, Oregon, helps the property owner, who lives in the lot’s primary residence, pay her home mortgage.

- accessory apartment
- alley flat
- back house
- backyard bungalow
- basement apartment
- carriage house
- coach house
- garage apartment
- granny flat
- guest house or cottage
- in-law suite
- laneway house
- mother-daughter house
- multigenerational house
- ohana unit
- secondary dwelling unit
- sidekick

PHOTO AND LIST FROM ACCESSORYDWELLINGS.ORG

Since ADUs can be created in many different shapes and styles, they're able to fit discreetly into all sorts of communities, including suburban subdivisions, row-house streets (either with or without back-alleys), walkable town or urban neighborhoods — and, of course, large lots and rural regions.



◀ A **DETACHED ADU** (aka DADU) is a stand-alone home on the same lot as a larger, primary dwelling. Examples include backyard bungalows and converted outbuildings.

Location: Portland, Oregon | Photo by David Todd



▶ An **ATTACHED ADU** connects to an existing house, typically through the construction of an addition along the home's side or rear. Such units can have a separate or shared entrance.

Location: Davidsonville, Maryland | Photo by Melissa Stanton, AARP



◀ A **GARAGE ADU** makes use of an attached or detached garage by converting the space into a residence. Other options involve adding a second-story ADU above a garage or building a new structure for both people and cars.

Location: Portland, Oregon | Photo by Radcliffe Dacanay

An **INTERNAL ADU** is created when a portion of an existing home — an entire floor, part of a floor, or an attic or basement — is partitioned off and renovated to become a separate residence.

▶ Access to an **UPPER-LEVEL ADU** can be provided through a stairway inside the main home or directly from an exterior staircase. This 500-square-foot ADU sits atop a 1,900-square-foot primary dwelling.

Location: Portland, Oregon | Photo by Eli Spevak, Orange Splot LLC



▲ A **LOWER-LEVEL ADU** is typically created through the conversion of a home's existing basement (provided that height and safety conditions can be met), during construction of the house, or (see page 7) as part of a foundation replacement and house lift.

Location: Portland, Oregon | Photo by Derin Williams

# ADUs Are Good for People and Places

Communities that understand the benefits of ADUs allow homeowners to create them

## ADUs are an affordable housing option

- ADUs can generate rental income to help homeowners cover mortgage payments or simply make ends meet. The income provided by an ADU tenant can be especially important for older people on fixed incomes.
- Since the land on which an ADU is built already belongs to the homeowner, the expense to build a secondary residence is for the new structure only. The lot is, in a sense, free.
- ADUs are typically owned and managed by homeowners who live on the premises. Such landlords are less likely to raise the rent once a valued tenant has moved in. Many ADUs are created for family members to reside in for free or at a discounted rate.
- Although market rate rents for ADUs tend to be slightly more than for similarly sized apartments, they often represent the *only* affordable rental choices in single-family neighborhoods, which typically contain no studio or one-bedroom housing options at all.
- Some municipalities are boosting ADUs as part of affordable housing and anti-displacement strategies. Santa Cruz, California (see opposite), is among the cities with programs to help lower-income households build ADUs or reside in them at reliably affordable rents.

## ADUs are able to house people of all ages

- An individual’s housing needs change over time, and an ADU’s use can be adapted for different household types, income levels, employment situations and stages of life.
- ADUs offer young people entry-level housing choices.
- ADUs enable families to expand beyond their primary home.
- ADUs provide empty nesters and others with the option of moving into a smaller space while renting out their larger house or letting an adult child and his or her family reside in it.

## ADUs are just the right size

- Generally measuring between 600 and 1,000 square feet, ADUs work well for the one- and two-bedroom homes needed by today’s smaller, childless households, which now account for nearly two-thirds of all households in the United States.

## ADUs are good for the environment

- ADUs require fewer resources to build and maintain than full-sized homes.
- ADUs use significantly less energy for heating and cooling. (Of all the ADU types, internal ones tend to have the lowest building and operating costs.)

## ADUs are community-compatible

- ADUs offer a way to include smaller, relatively affordable homes in established neighborhoods with minimal visual impact and without adding to an area’s sprawl.
- ADUs provide a more dispersed and incremental way of adding homes to a neighborhood than other options, such as multistory apartment buildings. As a result, it’s often easier to get community support for ADUs than for other housing types.

### Big houses are being built, small houses are needed

**Do we really need more than three times as much living space per person as we did in 1950? Can we afford to buy or rent, heat, cool and care for such large homes?**

YEAR	1950	2017
Average square footage of new single-family homes	983	2,571
Number of people per household	3.8	2.5
Square feet of living space per person	292	1,012

**Fact:** ADUs house more people per square foot of living area than single-family homes do.

SOURCE: NATIONAL ASSOCIATION OF HOME BUILDERS (AVERAGE HOME SIZES); U.S. CENSUS BUREAU (AVERAGE HOUSEHOLD SIZES)

## HOME VISIT #1 Attached ADU Addition

Santa Cruz, California

Size: 500 square feet



AARP

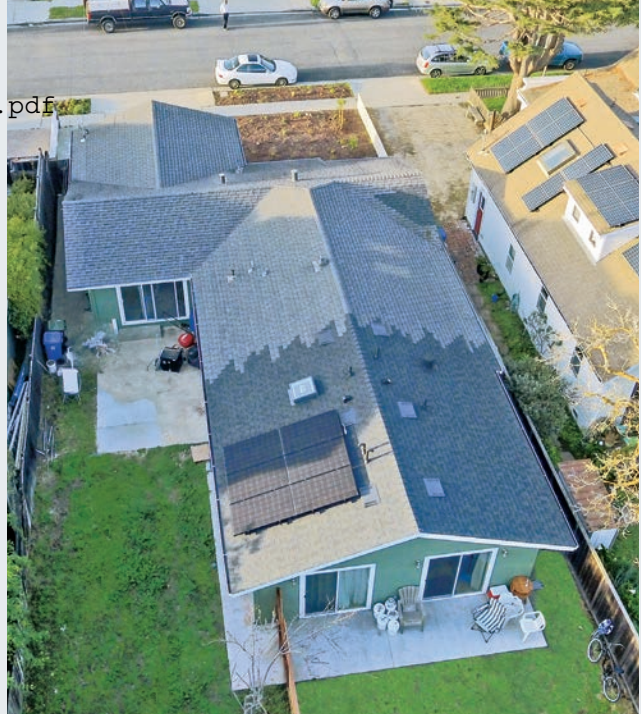

- ▲ The area with the darker roof shingles is the ADU that was added onto the home of Carrie and Sterling Whitley.
- ◀ ▼ The Whitleys' ADU (that's Carrie showing off the front yard's new paths and plantings) has its own entrance on the side of the home and is being rented to the couple's daughter so she can help her elderly parents when needed.

When Carrie and Sterling Whitley bought their house in 1971, they paid less than \$15,000. Nearly 50 years later, similar homes on their street have sold for more than \$1 million.

**THE PROBLEM:** The Whitleys, who are in their 80s, own the house outright and don't want to move. But the financial and physical demands involved in maintaining the house are a challenge.

**A SOLUTION:** To help low-income homeowners age 62 or older live independently and keep their homes, the Monterey Bay affiliate of Habitat for Humanity and the City of Santa Cruz launched My House My Home: A Partnership for Aging-in-Place. The pilot program builds accessory dwelling units so older homeowners can downsize into a new, aging-friendlier home and earn rental income from their original house. Or such homeowners can remain in their house and rent out the new, smaller residence. Participating homeowners are required to charge an affordable rental rate.

**REALITY CHECK:** When the Whitleys' project broke ground in April 2017, they were the first homeowners to receive an ADU through the program, which worked with them to design the ADU as an addition to their existing home. Since the dwelling was built with accessibility features, Carrie and Sterling know they can downsize into it if they ever need to. Until then, their daughter, Brenda, resides in the addition.

**REAL LIFE:** "I'm right next door to my parents in case they need me or need any help," Brenda says.

*Design: Historic Sheds | Builder: Historic Sheds | Cost to build: \$158,000 in 2017 (not including volunteer labor) | Photos by Michael Daniel | Article adapted from Where We Live: Communities for All Ages (AARP 2018)*



**ADU ADVICE:** With an attached ADU, privacy between the two residences can be achieved by locating the ADU bedroom(s) and bathroom(s) as far as possible from the main house. Providing the ADU with its own yard or outdoor space is helpful too.

# ADUs Are an American Tradition

**While today's interest in ADUs may be new, the housing type is centuries old**

Early settlers often built a small home to live in while constructing their larger, primary house nearby.

When farming was a source of survival for most of the nation's households, families routinely constructed additional homes on their land when needed.

People with wealth and acreage regularly populated their lands with secondary mansions and ancillary buildings independent of the main estate house.

In fact, until the 20th century, people with land built as many homes as they wished. There were few or no zoning rules, municipal services or infrastructure (utilities, roads, schools, trash collection, first-responders) to consider.

A historic precedent for the modern day accessory dwelling unit is the "carriage house," or "coach house." Originally built for horse-drawn carriages, the structures associated with grander homes were frequently large enough to double as living quarters for workers and stable hands.

Decades later, in response to housing shortages and economic needs, many surviving carriage houses were

converted into rental homes. By becoming landlords, the owners gained income from their otherwise unused outbuildings.

Automobile garages have a similar history. Some were originally built with a housing unit upstairs. Over time, many garages were converted (often illegally or under zoning codes no longer applicable today) into small homes when the spaces became more valuable for housing people than vehicles.

With the rise of suburban single-family home developments following World War II, ADUs practically ceased to be built legally in the United States. Then as now, residential zoning codes typically allowed only one home per lot, regardless of the acreage and with no exceptions. Attached and detached garages occupied yard space that might otherwise have been available for ADUs.

Some cities, including Chicago, grandfathered in pre-existing ADUs — but only if the residences remained consistently occupied. In Houston's historic and trendy Heights neighborhood, old and new garage apartments are common and desired.

But elsewhere, even in rural areas with ample land, property owners are often prohibited from creating secondary dwellings. Many communities today don't allow new ADUs, even if they did in the past — and even if ADUs currently exist there. (Countless units in single-family homes or yards are technically illegal or are allowed simply because they were created when such residences had been legal.)

ADUs began making a comeback in the 1980s as cities explored ways to support smaller and more affordable housing options within single-dwelling neighborhoods. In 2000, in response to a growing demand for ADU-supportive guidelines, AARP and the American Planning Association partnered to release an influential model state act and local code for ADUs.

More recently, there's been renewed interest at the state and local levels (see page 8) in legalizing and encouraging the creation of ADUs, driven by the increasingly high cost of housing and, in some places, the belief that homeowners with suitable space shouldn't be so restricted in the use of their property.

▼ **This carriage house containing a one-bedroom, one-bath ADU above a two-car garage sits behind a six-level, Gilded Age, Hoboken, New Jersey, townhome that was built in 1883. The dual residence property was on the market in 2018 for \$5 million.**





## HOME VISIT #2

# Garage Apartment ADU

Denver, Colorado

**Size:** 360 square feet



▲ The apartment above the garage can be reached from inside the garage or from an exterior side entrance accessed from the yard it shares with the primary residence.

“I see our ADU as something very similar to a student loan,” says Mara Owen. “It’s something you invest in the future with. It was cheaper than buying a house for Mom, and it lets her have independence. It’s great knowing we can check in on her whenever.”

**AH-HA MOMENT:** Owen, her partner, Andrew, and their three dogs were sharing a one-bedroom, one-bath house with her mother, Diane. When Owen learned that ADUs were allowed in the city, she decided the best way to get more space for her small home’s many residents would be to remove their “leaky and defunct” garage and build a new two-car garage with an apartment above it.

**WISE ADVICE:** “Get a really great builder and architect,” says Owen. “Interviewing architects was similar to a first date. It’s not just who you feel connected with. That’s important, but get to the values. It’s a niche market, so see if you can find someone who has built ADUs before, because ADUs are a little different.”

**FUTURE PLANS:** The stairs to Diane’s apartment are wide enough for a stair lift, if it’s ever needed. The roof was built at the correct slope for the eventual installation of solar panels.

*Design: Hive Architecture | Builder: Hive Architecture | Cost to build: \$167,000 in 2016 | Photo by Mara Owen | Article adapted from “ADU Case Studies” by Lina Menard on AccessoryDwellings.org. Visit the website to read about and see photographs of more ADU projects.*

## HOME VISIT #3

# Basement ADU

Portland, Oregon

**Size:** 796 square feet

The transformation of this colorful Victorian was both a preservation and expansion project.

**TEACHING MOMENT:** “Here’s a very welcome breath of fresh air, especially in the face of so much gentrification that is going on in Portland!” declared Mark Lakeman, principal of Communitecture, an architectural, planning and design firm, about the pictured remodel. Writing on his company’s website, he says the project provides a lesson in how to “adapt and reuse our precious historic houses so they can accommodate more people while also providing more income to support the existing home.”

**HOW’D THEY DO IT?** To add a basement rental unit, engineers lifted the house. The resulting ADU is roughly four feet underground and four feet above.

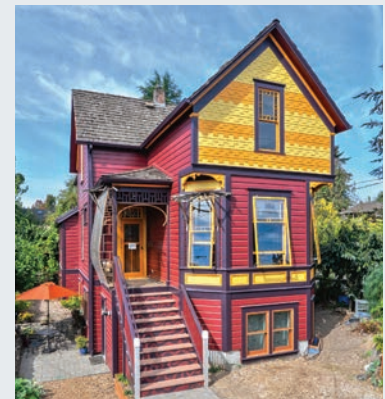

▲ By lifting the house and digging beneath it, designers, engineers and builders turned a two-story, single-family home into a three-story, multifamily residence.

**THE ACHIEVEMENT:** Adds Lakeman: “Unlike the seemingly pervasive method of simply tearing down existing buildings so that new, giant ones can be built, this approach achieves upgrades in energy efficient living places and adds density while retaining the continuity of our beloved historical urban environment.”

*Design: Communitecture | Home Lift: Emmert International | Builder: Tom Champion | Cost to build: \$125,000 in 2015 | Photos by Communitecture (before) and Chris Nascimento (after)*

# The Time Is Now

## Rules for ADUs continue to evolve and frequently differ from one town to the next

Some communities allow almost any home to be set up with an ADU — so long as size limits, property line setbacks and placement caveats in relation to the primary dwelling are met.

Other communities start with those basic standards and then layer on extra requirements (see page 14) that can make it challenging to create an ADU.

Municipalities nationwide have been relaxing their restrictions against ADUs, and some states have been encouraging their creation by requiring communities to allow them.

- In 2017, California required all of its cities and counties to allow ADUs so long as the property owner secured a building permit. In Los Angeles, Mayor Eric Garcetti has said ADUs could provide the city with a needed 10,000 housing units. He’s touted ADUs as a “way for homeowners to play a big part in expanding our city’s housing stock and make some extra money while they’re at it.”
- That same year, a New Hampshire law established that local zoning codes had to allow ADUs nearly everywhere single-family housing was permitted. The change stemmed in large part from the frustration of builders who couldn’t construct the type of amenities, such as backyard cottages and garage apartments, that their clients desired.
- Oregon requires cities and counties of certain sizes within urban growth boundaries to allow ADUs in all single-family neighborhoods.
- As of 2019, major cities that allow ADUs include Anchorage, Alaska; Atlanta, Georgia; Austin, Texas; Denver, Colorado; Honolulu, Hawaii; Houston, Texas; Philadelphia, Pennsylvania; Phoenix, Arizona; Seattle, Washington; and Washington, D.C. Communities in Massachusetts, Kentucky, Illinois, Indiana and Oregon have sought advice from AARP and Orange Spout about revising their zoning codes to allow ADUs.

► **The unique floor plan of this single-family Maryland farmhouse allows for a first floor residence (accessed through the door on the right) and an upper-level ADU that can be reached through the entrance at left.**

### To Encourage ADUs

#### LOCAL OFFICIALS can ...

- allow all ADU types (detached, attached, interior)
- simplify the building permit process for ADUs
- waive or reduce permit and impact fees
- let garages be converted into ADUs without requiring replacement off-street parking
- allow a second ADU if one of the homes on the property meets accessibility standards

#### COMMUNITY PLANNERS can ...

- adopt simple, flexible but nondiscretionary ADU rules about setbacks, square footage and design compatibility with the primary dwelling

#### LENDERS can ...

- work with homeowners to finance the construction of ADUs by using renovation loans

#### ADVOCATES can ...

- organize tours of completed ADUs in order to inform and inspire the community
- educate homeowners, real estate agents, architects and builders about local zoning regulations and the permit process

#### REAL ESTATE AGENTS can ...

- educate themselves and their clients about rules for the construction of ADUs

#### LOCAL MEDIA can ...

- report on how and why homeowners build ADUs



PHOTO BY MELISSA STANTON, AARP

## HOME VISIT #4

### Internal ADU (Main Level)

**Portland, Oregon**

**Size:** 220 square feet

Even small homes can have enough space for an ADU. An underused main floor bedroom in this 1.5-story, 1,500-square-foot bungalow was transformed into a studio apartment.

**AH-HA MOMENT:** According to Joan Grimm, who owns the home with Rita Haberman: “What we were looking for in terms of a community and aging in place was right under our noses. Remove a fence and create a shared open space. Build a wall and create a second dwelling unit. It doesn’t have to be complicated.”

**REAL LIFE:** “Creatively carving out an ADU from the main floor of our house saved on design and construction costs,” Grimm adds. “It provides an opportunity for rental income, with no significant compromise to the livability of our home.”

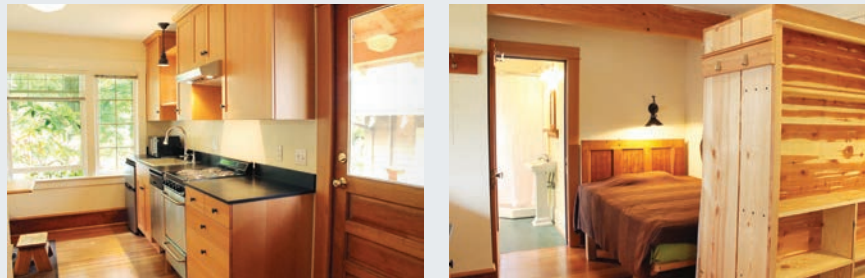

▲ The steps and side entrance (top) lead to the studio apartment ADU, which was crafted out of an existing space. The covered porch to the right leads to the primary residence. The ADU contains a kitchen, small dining and living area, sleeping area, bathroom and laundry area.

*Design: Rita Haberman | Builder: RS Wallace Construction | Cost to build: \$55,000 in 2015 (with some work done by the homeowners)  
Photos courtesy Billy Ulmer | Article adapted from “ADU Case Studies” by Lina Menard on AccessoryDwellings.org*

## HOME VISIT #5

### Internal ADU (Lower Level)

**Portland, Oregon**

**Size:** 795 square feet

“We were looking for a way to live in our house for the rest of our lives and to generate at least some income in the process,” Robert Mercer and Jim Heuer wrote for the program guide of the annual Portland ADU Tour when their home was part of the lineup. “An ADU offers the possibility of caregiver lodging in the future or even a place for us to live while we rent out the main house if we get to the point where we can’t handle the stairs any longer.”

**THE SOUND OF SILENCE:** Internal ADUs often require that soundproofing insulation be installed between the primary dwelling and the accessory unit that’s below, above or beside it. In Portland, the building code for duplex residences requires a sound insulation rating of at least STCC45. To property owners thinking about a similar ADU setup, the duo advise: “Think about how you live in your home and

▼ The door to the right of the garage leads to a ground-floor ADU with windows along the back and side walls. The upper-level windows seen below are part of the main residence.



how having downstairs neighbors will change what you can and can’t do with your space and what investment you are prepared to make in sound insulation.”

**AN ADDED BONUS:** “We are pleased that we have been able to provide more housing density on our property and still be in keeping with the historic character of our home.”

*Design: DMS Architects | Builder: Weitzer Company | Cost to build: \$261,000 in 2016 | Photo by Melissa Stanton, AARP | Article adapted from the 2017 ADU Tour project profiles on AccessoryDwellings.org*

# Bringing Back ADUs

The reasons for creating or living in an ADU are as varied as the potential uses

ADUs are flexible. Over time, a single ADU might be used in many ways as an owner's needs and life circumstances change. Following are just a few reasons why ADUs are created and by whom:

**EMPTY NESTERS** can build an ADU and move into it, then rent out the main house for supplemental income or make it available to their adult children.

**FAMILIES WITH YOUNG CHILDREN** can use an ADU as housing for a nanny or au pair or even a grandparent or two, who can then help raise their grandkids and be assisted themselves as they age.

**INDIVIDUALS IN NEED OF CARE** can reside in an ADU to be near family members, or they can use the ADU to house a live-in aide. (In fact, ADUs can be an affordable and more comforting alternative to an assisted-living facility or nursing home.)

**HOME BUYERS** can look forward to the rental income from an ADU to help pay their mortgage or finance home improvements, especially in expensive housing markets.

**HOME-BASED WORKERS** can use an ADU as their office or workshop.

**HOMEOWNERS** can use an ADU for guests or as housing for friends or loved ones who:

- aren't yet financially independent, such as new high school or college graduates
- need temporary housing due to an emergency or while renovating their own home
- have disabilities but can live independently if family reside nearby



▲ The zoning code in Evanston, Illinois, permits accessory dwelling units, creating an opportunity for the owners of this 1911 home with an outbuilding in the backyard.

## Planning and Paying for ADUs

Most new homes are built by developers, entire subdivisions at a time. Apartments are also built by pros.

But ADUs are different.

Although ADUs are occasionally designed into new residential developments, the vast majority are created by individual homeowners after they move in. In other words, ADUs are usually created by enthusiastic and motivated *amateurs*.

An ADU may present the ultimate chance for a do-it-yourselfer to build his or her small dream home. More often, homeowners bring in a combination of architects, designers and construction contractors to do the work, much as they would for a home addition or major kitchen remodeling. The local municipality's planning department can provide guidance on the rules for ADUs and information about what permits, utility connections and fees are involved.

ADUs aren't cheap, and they are often the most significant home improvement project a homeowner will undertake.

Although internal ADUs can sometimes be built for about \$50,000, new detached ADUs often exceed \$150,000. Most ADUs are financed through some combination of savings, second mortgages, home equity lines of credit and/or funds from family members (sometimes a relative who ends up living in it).

In some areas, the cost of building an ADU can be recouped after a few years of renting it. If that's the plan, it's worth estimating the expenses versus the potential income before undertaking an ADU project.

A few cities, nonprofits and start-ups are experimenting with creative financing options that could put ADUs within reach for more homeowners and their families, as well as prospective renters.



## HOME VISIT #6 Detached ADU (One-Story)

Decatur, Georgia

**Size:** 800 square feet

When Walt Drake decided to downsize, his son Scott purchased his dad's house for himself and his family and built a detached ADU (or DADU) for Walt.

“From not finding what we wanted for Dad, we decided to create it,” says Scott. “Neighborhoods built in the 1920s have carriage houses. Building an ADU was a modern day version of something people have been doing on their property in this area for a hundred years.”

**NEAR AND FAR:** “We wanted the houses to be separate and to feel like we're each on our own property, but we're there for each other,” says Scott.

**AGING-FRIENDLY:** Building the ADU meant Walt didn't have to sell his home and leave his neighborhood. “He was able to keep his own stuff and turn over what he didn't need to us,” says Scott. “It kept my dad in place, which I think was important.”

**FUTURE PLANS:** Scott says the ADU is “serving its intended purpose” but that someday down the road it could be used as a long- or short-term rental. “The ADU could turn into lots of different things over the course of its lifetime.”

*Design: Adam Wall, Kronberg Wall | Builder: Rob Morrell | Cost to build: \$350,000 in 2014 | Photo by Fredrik Brauer | Floor plan by Kronberg Wall Architects | Article adapted from “ADU Case Studies” by Lina Menard on AccessoryDwellings.org*

▲ Walt Drake's Southern-style, one-bedroom ADU has an outdoor, wraparound porch that can be accessed without using steps. The design is in keeping with other buildings in the neighborhood.

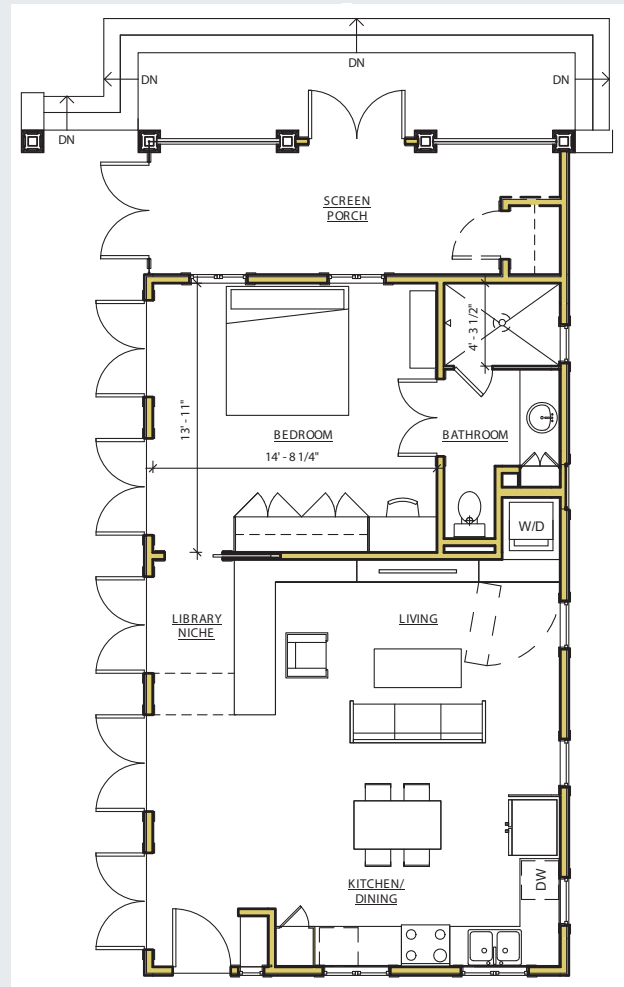

# ADUs Are Age-Friendly Housing

## New-construction ADUs can be created with “universal design” features

An “age-friendly” home has a zero-step entrance and includes doorways, hallways and bathrooms that are accessible for people with mobility differences. Garage conversions (such as the one pictured on page 2) are among the easiest and least expensive ADU solutions for aging in place since they’re preexisting structures and generally have no-step entries. To learn more about making a home aging-friendly, download or order the *AARP HomeFit Guide* at [AARP.org/HomeFit](http://AARP.org/HomeFit).

### HOME VISIT #7

## Detached ADU (Two-Story)

**Seattle, Washington**

**Size:** 800 square feet

Evelyn Brom’s plan was to build a backyard cottage and rent it out. She would keep living in her two-bedroom home.

**AH-HA MOMENT:** As the design developed, Brom realized that *she* wanted to live in the stunning wood-and-glass ADU. It was a good decision. A week before moving in, Brom was laid off from her job.

**REAL LIFE:** The \$3,000 a month Brom receives in rent for the main house (which is occupied by a three-generation family) provides a needed income. “Being laid off has made this arrangement a lifesaver,” Brom says. If the stairs in the cottage ever become too hard to navigate, she can move back into her original one-story house and rent out the cottage instead. “Now I have options,” she says.

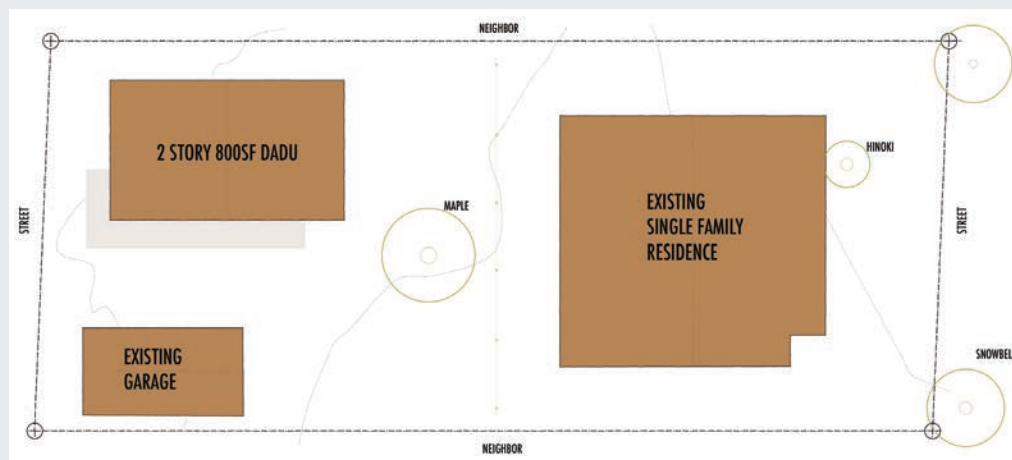

▲ There’s a powder room, open kitchen and living room on the first floor, with a bedroom and bathroom upstairs.

◀ Although Brom’s property is only 0.13 acres, it’s large enough to accommodate two homes, a patio, a lawn and a garage. A slatted wood fence with a gate divides the space between the two houses and provides privacy.

*Design: Chrystine Kim, NEST Architecture & Design | Builder: Ian Jones, Treebird Construction | Photo by Alex Hayden | Cost to build: \$250,000 in 2014*  
 Article adapted from *Where We Live: Communities for All Ages* (AARP 2018)

## HOME VISIT #8

# Detached Bedroom

**St. Petersburg, Florida**

**Size:** 240 square feet

Bertha and her son John talked about someday buying a house with a mother-in-law suite. “Then one day someone came along and wanted my house, so I up and sold it,” she explains. “But that left me homeless. I asked John if I could build a small house in his backyard and he agreed.”

**CREATIVE THINKING:** A detached bedroom is a permanent, accessory structure that, unlike ADUs, lacks a kitchen. But that’s what makes these cabin-like homes more affordable to build than many ADUs and even tiny houses.

**WHAT’S INSIDE:** Bertha’s home contains a sleeping and living area and a full bathroom. “I paid for the little house and it’s on my son’s property. So I figured, if I’m cooking I can do it at my son’s house,” she says. (Her laundry is also done at his house.)



▲ A detached bedroom, which contains a bathroom but no kitchen, can provide housing for a loved one or serve as a home office or guest cottage.

**REAL LIFE:** “Having access to my son’s house makes it livable. Otherwise, I personally would not be happy. It’s very comforting to know that John is close by. Hopefully this will be my home forever.”

*Design: Historic Sheds | Builder: Historic Sheds | Cost to Build: \$50,000 in 2017 | Photo by Historic Sheds | Article adapted from “ADU Case Studies” by Lina Menard on AccessoryDwellings.org*

## A Sustainable and Sunny ADU

Tired of living in a house with so many walled off and dark spaces that the sun couldn’t shine in, the home’s owners built and moved into the bright, airy, modern and very accessible ADU they created in their yard. (The original, larger home has become a rental.) The ADU is located within a conservation district and was constructed using sustainable materials and environmentally friendly techniques. One such feature is the deck trellis, which allows light in while diffusing the heat of the afternoon sun.

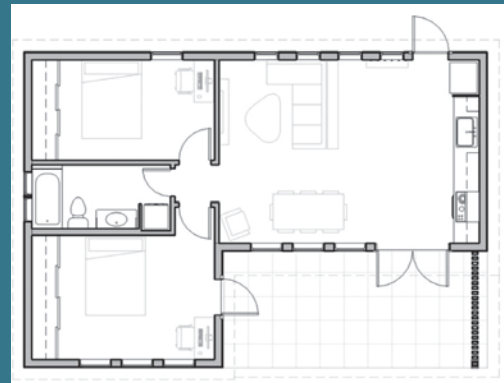

▲ Although this ADU has only 721 square feet of living space, there is room enough for two bedrooms.

*Design: Propel Studio | Builder: JLTB Construction | Photo by Josh Partee | Cost to build: \$185,000 in 2017 | Article adapted from “ADU Case Studies” by Lina Menard on AccessoryDwellings.org*

# Practical Solutions for ADUs

## Local laws can both allow and appropriately control the creation of accessory dwellings

There are more than 19,000 cities, 16,000 towns and 3,000 counties in the United States. Regulations about ADUs are typically written or adopted at the local government level.

Where it's legal to build ADUs, homeowners still need to follow rules about where it can be done, how tall they can be, how many square feet they can contain, what they can look like and how they can be used. These rules can be found in the local zoning code.

Over the past few decades it has become clear that there's a balance to strike between the strictness of ADU regulations and how often ADUs get built.

For instance, after Portland, Oregon, relaxed its ADU rules in 2010 and waived impact fees (a savings of up to \$12,000), the number of ADUs built there increased from about 30 per year between 2000 and 2009 to practically one ADU a day in 2015.

Changes in California's ADU laws allowed Los Angeles to achieve an even more dramatic increase, going from 80 permit applications in 2016 to nearly 2,000 in 2017. Allowing both an ADU and a "Junior ADU," or JADU — an interior ADU of 500 square feet or fewer — on properties in Sonoma County were among the urgent

policies adopted in the wake of Northern California's many devastating fires.

Meanwhile, in many jurisdictions, well-intentioned but burdensome rules can stymie the creation of ADUs. ADU-related zoning codes should be restrictive enough to prevent undesirable development but flexible enough that they actually get built.

When a community is worried about a potentially undesirable outcome, it can — and many do — craft regulations to prevent particular building types, locations or uses. A city concerned about the environmental impact of new structures might prohibit placing detached ADUs in precarious locations, such as on steeply sloping lots. Communities wary of ADUs becoming, for instance, off-campus student housing could establish occupancy rules.

Every community has its own priorities and concerns, and there's a wide enough range of regulatory controls that communities can write appropriate ADU rules.

This inherent flexibility in the form and function of ADUs allows them to pass political muster and get adopted in a wide range of places. (See page 16 for more about uses and rules.)

### Rules that discourage ADUs

- ADU-specific regulations that don't also apply to primary dwellings (e.g., owner-occupancy requirements)
- complex design compatibility criteria and approval steps
- off-street parking requirements beyond those required for the primary dwelling
- restrictions that limit ADUs to certain geographic areas, particular zoning categories or to large lots
- caps on square footage relative to the primary house that make it easy to add an ADU to a large home but hard or impossible to add one to a small home

**TRADING SPACES:** An ADU is always the smaller of two dwellings on a property, but it's possible for an existing home to become the ADU when a larger house is built and becomes the primary dwelling.

### Are ADUs allowed in your community?

**Find out by calling the office in charge of land use and permits or stopping by in person. You can also search for and read the zoning code through the local government's website.**

- If ADUs are allowed, ask what conditions, permit needs and impact fees apply.
- If ADUs are not allowed in your community and you want them to be, ask an elected official or the local department of zoning and planning for information about how the codes can be updated. Then get organized and start advocating!



# Creating (or Understanding) an ADU Zoning Code

**The ADU section of a community’s zoning code needn’t be overly complicated. It just needs to establish clear, objective and fair rules for the following:**

**1. A Definition:** A good zoning code clearly defines its terminology. Here, for example, is a useful outline for what, in the real world, is a very fluid term: “An ADU is a smaller, secondary home on the same lot as a primary dwelling. ADUs are independently habitable and provide the basic requirements of shelter, heat, cooking and sanitation.”

**2. The Purpose:** This is where the code describes key reasons a community allows ADUs. They should:

- increase the number of housing units while respecting the style and scale of single-dwelling development
- bolster the efficient use of existing housing stock and infrastructure
- provide housing that’s affordable and respond to the needs of smaller, changing households
- serve as accessible housing for older adults and people with disabilities

**3. Eligibility:** Who can build an ADU and on what type of property? A statement in this part of the code clarifies that an ADU can be placed only on a “residentially zoned, single-family lot.” (Some communities provide lot size standards, but many don’t.)

**4. Creation:** This is where the code sets out how an ADU can be built. For instance: “An ADU may be created through new construction, the conversion of an existing structure, as an addition to an existing structure or as a conversion of a qualifying existing house during the construction of a new primary dwelling on the site.”

**5. Quantity:** Most municipalities that permit ADUs allow one per lot. Vancouver, British Columbia; Sonoma County, California; and Tigard, Oregon, are among the few that allow two per lot (typically one internal and one external). Some communities also allow duplexes or townhomes to have ADUs, either in the backyard or on the ground floor.

**6. Occupancy and Use:** A code should state that the use-and-safety standards for ADUs match those that apply to the primary dwelling on the same property. (See page 17 for more about ADU uses.)

**7. Design Standards:**

- **Size and height:** A zoning code might specify exactly how large and tall an ADU is allowed to be. For instance, “an ADU may not exceed 1,000 square feet

or the size of the primary dwelling, whichever is smaller.” Codes often limit detached ADUs to 1.5 or 2 stories in height. (An example of that language: “The maximum height allowed for a detached ADU is the lesser of 25 feet at the peak of the roof or the height of the primary dwelling.”)

- **Parking:** Most zoning codes address the amount and placement of parking. Some don’t require additional parking for ADUs, some do, and others find a middle ground — e.g., allowing tandem parking in the driveway and/or on-street parking. (See page 16 for more about parking.)
- **Appearance:** Standards can specify how an ADU’s roof shape, siding type and other features need to match the primary dwelling or neighborhood norms. Some codes exempt one-story and internal ADUs from such requirements. (See page 16 for more about making sure that ADUs fit into existing neighborhoods.)
- **Entrances and stairs:** Communities that want ADUs to blend into the background often require that an ADU’s entrance not face the street or appear on the same facade as the entrance to the primary dwelling (unless the home already had additional entrances before the ADU was created).

**8. Additional Design Standards for Detached ADUs:**

- **Building setbacks:** Many communities require detached ADUs to either be located behind the primary dwelling or far enough from the street to be discreet. (A code might exempt preexisting detached structures that don’t meet that standard.) Although this sort of rule can work well for neighborhoods of large properties with large rear yards, communities with smaller lot sizes may need to employ a more flexible setback-and-placement standard.
- **Building coverage:** A code will likely state that the building coverage of a detached ADU may not be larger than a certain percentage of the lot that is covered by the primary dwelling.
- **Yard setbacks:** Most communities have rules about minimum distances to property lines and between buildings on the same lot. ADUs are typically required to follow the same rules.

Visit [AARP.org/ADU](https://www.aarp.org/adu) to see examples of ADU zoning codes from selected cities.

# ADU “Hot Topics”

**As communities allow ADUs or update existing zoning codes and rules to be more ADU-friendly, they inevitably wrestle with some or all of the following issues:**

## Adding ADUs to neighborhoods

Recognizing that ADUs may represent a new housing type for existing neighborhoods, communities often write special rules to ensure they'll fit in well. These guidelines typically address visual compatibility with the primary dwelling, appearance from the street (if the ADU can be seen) and privacy for neighbors.

Rules that help achieve these goals include:

- height and size caps mandating that ADUs be shorter and smaller than the primary dwelling
- requirements that detached ADUs be behind the main house or a minimum distance from the street
- mandates that the design and location of detached ADUs be managed the same way as other detached structures (e.g., garages) on the lot
- design standards for larger or two-story ADUs so they architecturally match the primary dwelling or reflect and complement neighborhood aesthetics
- encouragement for the creation of internal ADUs, which are often unnoticed when looking at the house

Each community can strike its own unique balance between strict rules to ensure that ADUs have a minimal impact on neighborhoods and more flexible rules that make them easier to build.

▼ A top floor ADU can be a suitable rental for a student or someone who travels a lot for work. ADU expert Kol Peterson grew up in a home with an attic ADU that was usually rented to law school students. “They had to walk up the primary house’s interior stairs in order to access the affordable attic unit,” he writes in *Backdoor Revolution: The Definitive Guide to ADU Development*. “Over the years that each of them lived there, the tenants became parts of our family.”



## Providing places to park

ADU regulations often include off-street-parking minimums on top of what’s already required for the primary dwelling. Such rules can prevent homeowners from building ADUs if there’s insufficient physical space to accommodate the parking. However, additional parking often isn’t needed.

Data from Portland, Oregon, shows that there are an average of 0.93 cars for each ADU, and that about half of all such cars are parked on the street. With fewer than 2 percent of Portland homes having ADUs (the highest percentage in the country), there is about one extra car parked on the street every six city blocks. This suggests that any impacts on street parking from ADUs are likely to be quite small and dispersed, even in booming ADU cities.

More-realistic parking rules might:

- require the creation of new parking only if the ADU displaces the primary dwelling’s existing parking
- waive off-street-parking requirements at locations within walking distance of transit
- allow parking requirements for the house and ADU to be met by using some combination of off-street parking, curb parking, and tandem (one car in front of the other) parking in a driveway

## Dealing with unpermitted ADUs

It’s not uncommon for homeowners to convert a portion of their residence into an ADU in violation (knowingly or not) of zoning laws or without permits.

Such illegal ADUs are common in cities with tight housing markets and a history of ADU bans. One example is New York City, which gained 114,000 apartments between 1990 and 2000 that aren’t reflected in certificates of occupancy or by safety inspections.

Some cities have found that legalizing ADUs, simplifying ADU regulations and/or waiving fees can be effective at getting the owners of illegal ADUs to “go legit” — and address safety problems in the process.

## Allowing and Restricting Uses

Communities get to decide whether to let ADUs be used just like any other housing type or to create special rules for them. Some municipalities take a simple approach, regulating ADUs just as they do other homes. So if a home-based childcare service is allowed to operate in the primary dwelling, it is also allowed in an ADU. Conversely, communities sometimes adopt ADU-specific regulations in order to avoid undesirable impacts on neighbors. Examples include:

### Limiting short-term rentals

ADUs tend to work well as short-term rentals. They're small and the owner usually lives on-site, making it convenient to serve as host. However, if ADUs primarily serve as short-term rentals, such as for Airbnb and similar services, it undermines the objective of adding small homes to the local housing supply and creating housing that's affordable.

In popular markets, short-term rentals can be more profitable than long-term ones, allowing homeowners to recoup their ADU expenses more quickly. In addition, short-term rentals can provide owners with enough income that they can afford to occasionally use the ADU for friends and family.

A survey of ADU owners in three Pacific Northwest cities with mature ADU and short-term rental markets found that 60 percent of ADUs are used for long-term housing as compared with 12 percent for short-term rentals.

Respondents shared that they "greatly value the ability to use an

ADU flexibly." For instance, an ADU can be rented nightly to tourists, then someday rented to a long-term tenant, then used to house an aging parent. ADUs intended primarily for visiting family are sometimes used as short-term rentals between visits.

Cities concerned about short-term rentals often regulate them across all housing types. If there are already rules like this, special ones might not be needed for ADUs. An approach employed in Portland, Oregon, is to treat ADUs the same except that any financial incentives (such as fee waivers) to create them are available only if the property owner agrees not to use the ADU as a short-term rental for at least 10 years.

### Requiring owner-occupancy

Some jurisdictions require the property owner to live on-site, either in the primary house or its ADU. This is a common way of addressing concerns that absentee landlords and their tenants will allow homes and ADUs to fall into disrepair and negatively impact the neighborhood.

Owner-occupancy rules are usually implemented through a deed restriction and/or by filing an annual statement confirming residency. Some cities go further, saying ADUs can be occupied only by family members, child- or adult-care providers, or other employees in service of the family.

Owner-occupancy requirements make the financing of ADUs more difficult, just as they would if applied to single-family homes. But as ADUs have become more common, owner-occupancy restrictions have become less so, which is good. Such requirements limit the appraised value of properties with ADUs and reduce options for lenders should they need to foreclose.

Enforcing owner-occupancy laws can be tricky, and the rules have been challenged in courts, sometimes successfully. However, according to a study by the Oregon Department of Environmental Quality, more than two-thirds of properties with ADUs are owner-occupied even without an owner-occupancy mandate.

## While not technically ADUs, tiny houses can serve a similar purpose

▶ Because tiny houses — such as the 100-square-foot "Lucky Penny," pictured — are built on a trailer with wheels rather than on a fixed foundation, they are typically classified as recreational vehicles (RVs) rather than permanent residences. Although tiny homes are usually smaller than 400 square feet, many of them do contain a kitchen and bathroom.





ABOVE-GARAGE ADU



DETACHED-BEDROOM ADU



DETACHED ADU

- An accessory dwelling unit is a small residence that shares a single-family lot with a larger primary dwelling.
- As an independent living space, an ADU is self-contained, with its own kitchen or kitchenette, bathroom and living/sleeping area. (Garage apartments and backyard cottages are each a type of ADU.)
- ADUs can enable homeowners to provide needed housing for their parents, adult children, grandchildren or other loved ones.
- An ADU can provide older adults a way to downsize on their own property while a tenant or family member resides in the larger house.
- Since homeowners can legally rent out an ADU house or apartment, ADUs are an often-essential income source.
- ADUs help to improve housing affordability and diversify a community's housing stock without changing the physical character of a neighborhood.
- ADUs are a beneficial — and needed — housing option for people of all ages.

Learn more about ADUs and  
order or download

## The ABCs of ADUs

by visiting  
[AARP.org/ADU](https://AARP.org/ADU)

Sign up for the free, weekly

### AARP Livable Communities e-Newsletter

Be among the first to learn when  
AARP releases more livability  
guides and resources.

[AARP.org/Livable-Subscribe](https://AARP.org/Livable-Subscribe)

**AARP**<sup>®</sup>

Real Possibilities

**CENTRAL PUGET SOUND  
GROWTH MANAGEMENT HEARINGS BOARD  
STATE OF WASHINGTON**

1000 FRIENDS OF WASHINGTON,	)	<b>Case No. 04-3-0018</b>
	)	
Petitioners,	)	
	)	<i>(1000 Friends IV)</i>
v.	)	
	)	
SNOHOMISH COUNTY,	)	<b>FINAL DECISION and ORDER</b>
	)	
Respondent.	)	
	)	
	)	

---

***SYNOPSIS***

*On March 31, 2004, Snohomish County adopted Ordinance 04-021 amending its regulation concerning accessory dwelling units (ADUs).<sup>1</sup> The Snohomish County Uniform Development Code (UDC), adopted in December of 2002, allowed attached and detached “accessory apartments” in rural areas under certain conditions but excluded the use of mobile or manufactured homes as ADUs anywhere in the County. Ordinance 04-021 amended the regulations concerning ADUs on lots of 200,000 square feet (4.7 acres) or larger to allow the use of mobile or manufactured housing as detached new structures and to modify size and compatibility restrictions. Petitioner challenges the Ordinance as increasing rural density in violation of the GMA.*

*The Board finds that the amendments to the ADU standards as applied to lots smaller than 10 acres promote “dwelling unit density that fails to protect rural lands and rural character” (Legal Issue #1). The Board therefore grants the petition in part and remands to the Respondent for action consistent with this decision.*

**I. BACKGROUND<sup>2</sup>**

**A. GENERAL**

On March 31, 2004, the Snohomish County Council adopted Ordinance 04-021 amending Snohomish County’s development regulations concerning accessory dwelling apartments. On June 14, 2004, 1000 Friends of Washington (**1000 Friends** or

<sup>1</sup> Snohomish County’s Code does not use the common term Accessory Dwelling Unit but rather uses the term “Accessory Apartments.” County Response, at 3 (fn.3).

<sup>2</sup> See Appendix A for more detail regarding the procedural history of this matter.

**Petitioner**) filed a Petition for Review (**PFR**) challenging Snohomish County's (**County** or **Respondent**) action.

During June and July of 2004, the Board issued the Notice of Hearing, conducted the Prehearing Conference and issued the Prehearing Order (**PHO**). The PHO set the schedule and established the legal issues to be decided by the Board.

On August 3, 2004, the Board received Petitioner's Motion for Summary Judgment (**1000 Friends Motion**) and Snohomish County's Motion to Dismiss (**County Motion**). Following a hearing by telephone conference call, the Board dismissed both motions without prejudice subject to further briefing and argument at the Hearing on the Merits.

The prehearing briefing received is referenced in this Final Decision and Order (**FDO**) as: Prehearing Brief of 1000 Friends of Washington (**1000 Friends PHB**), Snohomish County's Motion to Dismiss and Prehearing Brief (**County Response**), and Reply Brief of 1000 Friends of Washington (**1000 Friends Reply**). In these briefs and in oral argument, 1000 Friends renewed its motion for summary judgment and the County renewed its motion to dismiss.

On November 1, 2004, the Board held a Hearing on the Merits (**HOM**) at the Board's offices in Suite 2470, 900 Fourth Avenue, Seattle, Washington. Board Members Margaret A. Pageler, Presiding Officer, Edward G. McGuire, and Bruce C. Laing were present for the Board. Petitioner was represented by Ken Lederman of Riddell Williams P.S. Respondent was represented by Snohomish County Deputy Prosecuting Attorney Jason Cummings. Board externs Julie Taylor and Jessica Clawson also attended. Court reporting services were provided by J. Gayle Hays, of Byers & Anderson, Inc. The hearing convened at 10:00 a.m. and adjourned at approximately 11:00 a.m. The Board did not order a transcript of the HOM.

## **II. PRESUMPTION OF VALIDITY, BURDEN OF PROOF AND STANDARD OF REVIEW**

Petitioner challenges Snohomish County's amendment of development regulations for accessory dwelling apartments, as adopted by Ordinance No. 04-021. Pursuant to RCW 36.70A.320(1), Ordinance No. 04-021 is presumed valid upon adoption.

The burden is on Petitioner, 1000 Friends of Washington, to demonstrate that the actions taken by the County are not in compliance with the requirements of the GMA. RCW 36.70A.320(2).

Pursuant to RCW 36.70A.320(3), the Board "shall find compliance unless it determines that the action taken by [the County] is clearly erroneous in view of the entire record before the board and in light of the goals and requirements of [the GMA]." For the Board to find Snohomish County's actions clearly erroneous, the Board must be "left with the

firm and definite conviction that a mistake has been made.” *Dep’t of Ecology v. PUD 1*, 121 Wn.2d 179, 201 (1993).

Pursuant to RCW 36.70A.320(1) the Board will grant deference to the County in how it plans for growth, consistent with the goals and requirements of the GMA. The State Supreme Court has stated, “Local discretion is bounded, however, by the goals and requirements of the GMA.” *King County v. Central Puget Sound Growth Management Hearings Board*, 142 Wn.2d 543, 561, 14 P.3d 142 (2000). Division II of the Court of Appeals further clarified, “Consistent with *King County*, and notwithstanding the ‘deference’ language of RCW 36.70A.3201, the Board acts properly when it foregoes deference to a county’s plan that is not ‘consistent with the requirements and goals of the GMA.’” *Cooper Point Association v. Thurston County*, 108 Wn.App. 429, 444, 31 P.3d 28 (2001).

In affirming the *Cooper Point* court, the Supreme Court recently stated:

Although we review questions of law *de novo*, we give substantial weight to the Board’s interpretation of the statute it administers. *See Redmond*, 136 Wn.2d at 46. Indeed “[I]t is well settled that deference [to the Board] is appropriate where an agency’s construction of statutes is within the agency’s field of expertise...”

*Thurston County v. Western Washington Growth Management Hearings Board*, 148 Wn.2d 1, 15, 57 P.3d 1156 (2002).

### **III. THE CHALLENGED ACTION AND PREFATORY NOTE**

On March 31, 2004, Snohomish County adopted Ordinance 04-021 amending its regulation concerning accessory dwelling units. The Snohomish County Uniform Development Code (**UDC**), adopted in December, 2002, had allowed attached and detached “accessory apartments” in rural areas with certain floor area restrictions and compatibility requirements but had excluded the use of mobile or manufactured homes as ADUs anywhere in the County.<sup>3</sup> For lots of 200,000 square feet (4.7 acres) or larger, Ordinance 04-021 created an exception allowing the use of mobile or manufactured housing as detached ADUs and modifying floor area restrictions and compatibility requirements.<sup>4</sup>

---

<sup>3</sup> The 2004 amendments were in response to a citizen complaint about the prohibition against use of a mobile or manufactured home as a detached “mother-in-law” apartment on his 15-acre lot in the rural area. County Response, Ex.18.

<sup>4</sup> A mobile home is defined in the County Code as “a manufactured home that is a structure, transportable in one or more sections, which in the traveling mode, is eight body feet or more in width and forty body feet or more in length, or, when erected on site, is three hundred twenty or more square feet, and which is built on a permanent chassis and designed to be used as a dwelling with or without a permanent foundation when connected to the required utilities, and includes the plumbing, heating, air conditioning, and electrical systems contained therein.” SCC 30.91M.150, 1000 Friends Motion, Ex 1.

Petitioner challenges the Ordinance as increasing the rural density in violation of the GMA. Petitioner relies largely on Board precedents which set standards for rural density to prevent sprawl and which establish that allowing freestanding ADUs in the rural area effectively doubles the allowable density.

Respondent contends that the petition is an untimely challenge over which the Board has no jurisdiction. Alternatively, respondent argues that the Board should dismiss because Petitioner's case is not properly articulated in its statement of legal issues. If the Board reaches the merits of the issue, Respondent urges the Board to deny the petition because the Ordinance complies with the GMA.

In this Final Decision and Order, the Board addresses first the Respondent's motion to dismiss for lack of jurisdiction. The Board concludes that the Petitioner's challenge is timely and that the Board has jurisdiction to decide the case on the merits.

The Board then addresses the substantive development regulation amendment at issue. The Board finds that the amendment to the ADU regulations that allows manufactured homes<sup>5</sup> as detached new structures on lots of less than 10 acres in the rural area promotes "dwelling unit density that fails to protect rural lands and rural character" (Legal Issue #1). However, the Board finds that Petitioner fails to meet its burden of proof with respect to invalidity (Legal Issue #2). The Board therefore grants the petition in part, denies it in part, and remands to the Respondent for action consistent with this decision.

#### **IV. BOARD JURISDICTION**

##### *Position of the Parties*

Snohomish County challenges the Board's jurisdiction on the grounds that the petition was not timely filed pursuant to RCW 36.70A.290. The County's core argument is that allowance of detached ADUs in the rural area was established in the codification of the County's UDC in 2002 and thus the time to challenge the provision has long passed. County Response, at 10. The County's theory is that because Ordinance 04-021 did not amend *where* detached ADUs are allowed but only *when* such units are permitted, the amendment cannot be challenged. *Id.*, at 8.

1000 Friends responds that Ordinance 04-021 substantively amended the County's development regulations. Inasmuch as the petition challenges specific amendments, it is timely. 1000 Friends PHB, at 2.

---

<sup>5</sup> The Board notes that SB 6593 (Chapter 256, Laws of 2004) effective July 1, 2005, creates new requirements for city and county regulation of manufactured housing. Neither Petitioner nor Respondent cited this statute to the Board. We decline to speculate on its application when it becomes effective.



Applicable Law

RCW 36.70A.290(1) and (2) provide as follows:

(1) All requests for review to a growth management hearings board shall be initiated by filing a petition that includes a detailed statement of issues presented for resolution by the board....

(2) All petitions related to whether or not an adopted comprehensive plan, development regulation, *or permanent amendment thereto*, is in compliance with the goals and requirements of this chapter...must be filed within sixty days after publication by the legislative bodies of the county or city. (*Emphasis supplied*)

Board Discussion

The Board's jurisdiction is limited; the Board has "no jurisdiction to review substantive issues of an ordinance previously adopted and not challenged within the timeframe of the Act, *when those issues remain unchanged and unamended.*" *Guy Parsons et al., v. Mason County*, WWGMHB Case No. 00-2-0030 (Order Granting Dispositive Motion, November 27, 2000) at 3, *emphasis supplied*.<sup>6</sup>

Here the County's development regulations allowing detached ADUs have been substantively amended to allow mobile or manufactured housing, previously prohibited everywhere, to be constructed on lots of 200,000 square feet or more. RCW 36.70A.290(2) is clear that "permanent amendments" to previously adopted development regulations are subject to Board review. In other words, when an ordinance amends or expands portions of an existing development code, the *amendment* is subject to appeal within sixty days of publication. 1000 Friends PHB, at 8.<sup>7</sup>

Petitioner here makes timely challenge to an ordinance "amending the development standards" for ADUs. At the Prehearing Conference, the Legal Issue was restated as follows:

*Legal Issue #1: Does adoption of Ordinance 04-021, amending the development standards for Accessory Dwelling units (allowing for the construction of detached dwelling units on lots 200,000 square feet or larger), fail to comply with RCW 36.70A.020(2), RCW 36.70A.020(1), RCW 36.70A.020(9), RCW 36.70A.070(5), RCW 36.70A.110(1) when the*

---

<sup>6</sup> See also *Montlake Community Club v. Hearings Board*, 110 Wn. App. 731, 738-39, 43 P. 3d 57 (2002); *Torrance v. King County*, CPSGMHB Case No. 96-3-0038 (Order Granting Dispositive Motion, March 31, 1997) at 4.

<sup>7</sup>Citing *Tupper v. City of Edmonds*, CPSGMHB 03-3-0018 (Order on Dispositive Motions, December 3, 2003) at 8; *1000 Friends v. Chelan County*, EWGMHB 04-1-0002 (Order on Dispositive Motions, June 10, 2004).

*ordinance allows for dwelling unit density that fails to protect rural lands and rural character?*

The Board reads this legal issue as a challenge to the County's substantive amendment of its development regulations for ADUs. The substance of the amendment applicable to detached dwelling units on lots of 200,000 square feet or more is the exception for mobile or manufactured homes, which are allowed nowhere else in the ADU regulations.

The County's attempt to frame the petition as an untimely challenge to the preexisting regulation is not well founded. While the time for challenge of the original ADU rules is long past, that doesn't deprive the Board of jurisdiction to review new legislation to the extent that it may expand and increase a previously-unchallenged inconsistency with the GMA. The County's reliance on *Montlake Community Club v. Hearings Board*, 100 Wn.App. 731, 738-39, 43 P.3d 57 (2002) is misplaced. County Response, at 11. In *Montlake* the Board ruled, and the Court of Appeals agreed, that previously adopted and unchallenged development standards could not be challenged when those standards were applied to a new sub-area plan. Here, by contrast, the scope of the development standards are themselves substantively amended.

The Board finds that it has jurisdiction of a timely challenge to Snohomish County's development regulation amendments which change standards for ADU development on lots 200,000 square feet (4.7 acres) or larger.

### Conclusion

The Board finds that the Petitioner's PFR was timely filed, pursuant to RCW 36.70A.290; Petitioner has standing to appear before the Board, pursuant to RCW 36.70A.280(2)<sup>8</sup>; and the Board has subject matter jurisdiction over the challenged ordinance, which amends the County's development regulations, pursuant to RCW 36.70A.280(1)(a). Respondent's motion to dismiss is **denied**.

## **V. LEGAL ISSUES AND DISCUSSION**

### **LEGAL ISSUE NO. 1**

The Board's PHO set forth Legal Issue No. 1:

*Legal Issue #1: Does adoption of Ordinance 04-021, amending the development standards for Accessory Dwelling units (allowing for the construction of detached dwelling units on lots 200,000 square feet or larger), fail to comply with RCW 36.70A.020(2), RCW 36.70A.020(1), RCW 36.70A.020(9), RCW 36.70A.070(5), RCW 36.70A.110(1) when the*

---

<sup>8</sup> See 1000 Friends Motion, Ex. 6.

*ordinance allows for dwelling unit density that fails to protect rural lands and rural character?*

### **Applicable Law and Discussion**

#### **Position of the parties**

Petitioner argues that allowing mobile or manufactured homes as detached ADUs on rural lots increases density and alters the rural character. Petitioner relies on Growth Management Board precedents establishing that preservation of rural character requires a density of no more than one dwelling unit per five acres in the rural area, citing *Friends of the San Juans, et al. v. San Juan County (San Juan)*, WWGMHB Case No. 03-2-003c (Final Decision and Order, April 17, 2003); *Peninsula Neighborhood Association v. Pierce County (PNA II)*, CPSGMHB Case No. 95-3-0771 (Final Decision and Order, March 20, 1996); *Yanisch v. Lewis County (Yanisch)*, WWGMHB Case No. 02-2-0007c (Final Decision and Order, December 4, 2002). Petitioner notes that this Board and the Western Board have applied this standard to preclude detached ADUs on lots of less than 10 acres in the rural area, citing *PNA II* and *San Juan*. Petitioner invites this Board to rule as a matter of law that Snohomish County's amendments to its ADU regulations "double the allowable density" in the rural area. 1000 Friends PHB, at 21.

Snohomish County responds that its preexisting regulations allowed detached ADUs on large lots in rural zones and that therefore the amendments allowing manufactured homes do not increase allowable rural density. County Response, at 22-23. Alternatively, the County contends that the restrictions and conditions written into Ordinance 04-021 will ensure that rural character is protected as manufactured-home ADUs are developed. *Id.*, at 20-22.

#### **Applicable law**

RCW 36.70A.020(2) and (4)

Planning Goals. The following goals are adopted to guide the development and adoption of comprehensive plans and development regulations of those counties and cities that are required or choose to plan under RCW 36.70A.040...

(2) Reduce sprawl. Reduce the inappropriate conversion of undeveloped land into sprawling, low density development...

(4) Housing. Encourage the availability of affordable housing to all economic segments of the population of this state, promote a variety of residential densities and housing types, and encourage preservation of existing housing stock.

RCW 36.70A.110(1)

Each county that is required or chooses to plan under RCW shall designate an urban growth area or areas within which urban growth shall be encouraged and outside of which growth can occur only if it is not urban in nature....

RCW 36 70A.400

Accessory apartments. Any local government, as defined in RCW 43.63A.215,<sup>9</sup> that is planning under this chapter shall comply with RCW 43.63A.215(3).

RCW 43.63A.215 (1) and (3)

(1) The department [CTED] shall, in consultation with the affordable housing advisory board created in RCW 43.185B.020, report to the legislature on the development and placement of accessory apartments. The department shall produce a written report by December 15, 1993<sup>10</sup> which... (b) Makes recommendations to the legislature designed to encourage accessory apartments in areas zoned for single-family use...

(3) Unless provided otherwise by the Legislature, by December 31, 1994, local governments shall incorporate into their development regulations, zoning regulations, or official controls the recommendations contained in subsection (1) of this section. The accessory apartment provisions shall be part of the local government's development regulations, zoning regulation, and official control. To allow for local flexibility, the recommendation shall be subject to such regulations, conditions, procedures, and limitations as determined by the local legislative authority.

Board Discussion

1. Harmonizing the ADU requirement with the goal of preventing sprawl. RCW 43.63A.215(4)(b) requires that counties planning under the GMA make provision for ADUs. The apparent purpose of this legislation is to support the housing goals of the GMA – housing affordability, variety, and preservation. RCW 36.70A.020(4). The legislation offers no guidance on how to harmonize the ADU requirement with other goals and requirements of the GMA, particularly the goals of preventing sprawling, low-density development and protecting rural character. RCW 36.70A.020(2); RCW 36.70A.030(14).

The Petitioner correctly recognizes that the GMA emphasizes the importance of rural lands and rural character, demanding protection of rural lands through a comprehensive

---

<sup>9</sup> “Local governments” include counties required to plan under GMA. RCW 43.63A.215(4)(b).

<sup>10</sup> The Department produced a Model Ordinance, Accessory Dwelling Unit Ordinance and Study (Washington State Department of Community Development, January 1994). Neither party to the present appeal has referenced the Department's standards or guidance.

plan's "Rural Element." RCW 36.70A.011. To protect the rural element of a comprehensive plan, a county must control rural development, assure visual compatibility with the surrounding rural area, reduce inappropriate conversion of rural land into sprawl, protect critical areas, and prevent conflicts with the use of separately designated lands. RCW 36.70A.070(5)(c); *John Diehl v. Mason County*, 94 Wn.App. 645,655, 972 P.2d 543 (1999); *Butler v. Lewis County*, WWGMHB 99-2-0027c (Final Decision and Order, June 30, 2000).

Precedents from both this Board and the Western Washington Growth Management Hearings Board,<sup>11</sup> focusing on rural parcels of less than 10 acres, have used the distinction between *attached* ADUs and *detached* (freestanding new structures) to harmonize the ADU requirement with the goals of preventing low-density sprawl and protecting rural character.<sup>12</sup>

This Board examined Pierce County's ADU regulations in *Pierce County Neighborhood Association v. Pierce County (PNA II)*, Case No. 95-3-0071 (Final Decision and Order, March 11, 1996) and concluded:

Construction of a detached new ADU on a parcel smaller than 10 acres is generally prohibited because it would effectively allow two freestanding dwelling units. The effect would necessarily be one freestanding dwelling on a lot smaller than 5 acres, which the Board has previously held to constitute urban growth. Regardless of the size of the rural lot, ADUs attached to the main residence or a conversion of a detached existing structure (e.g., a garage) in close association with the primary residence would not constitute new urban growth.

*Id.*, at 22.

A similar issue was addressed more recently by the Western Board in Lewis County. In *Yanisch v. Lewis County (Yanisch)*, WWGMHB Case No. 02-2-0007c, (Final Decision and Order, December 11, 2002), the Western Board said: "We have consistently found that densities greater than 1 unit per five acres are not rural densities." The Western Board found that ADUs could be allowed in Lewis County as internal or attached units on single family lots of five acres or less. However, the Board ordered Lewis County to remove from the Lewis County Code the provisions that permitted detached ADUs on lots that did not contain the basic underlying rural density.

---

<sup>11</sup> To our knowledge, the Eastern Washington Growth Management Hearings Board has not considered this issue.

<sup>12</sup> *Alpine Evergreen et al. v. Kitsap County (Bremerton/Alpine)*, CPSGMHB Case No. 95-3-0039c (Order Rescinding Invalidity in *Bremerton* and Final Decision and Order in *Alpine*, February 8, 1999), at 40, cited in County Response, at 19, is not on point. The issue in *Bremerton/Alpine* was not rural density but whether allowance for ADUs must be factored into a County's land capacity allowance.

The most thorough and recent review of this issue is in *Friends of the San Juans, et al. v. San Juan County (San Juan)*, WWGMHB Case No. 03-2-0003c (Final Decision and Order, April 17, 2003). While the *San Juan* decision involves some facts unique to the guesthouse industry in the San Juan Islands, this Board finds the underlying analysis of the impact of ADUs as detached new structures in the rural area is persuasive.

At argument, we asked the County to explain how a freestanding ADU differs from a single-family residence. The County responded that an ADU is limited in size to no more than 1,000 square feet. So, we asked, how is a freestanding ADU different from a single family residence of 1,000 square feet? The County responded that there are certain site limitations that would apply to an ADU, although the County also conceded that the site limitations may be waived. Other than size and potential site restrictions, the County acknowledged that a freestanding ADU is not *structurally* distinguishable from a single-family residence, since single ownership of the ADU and the main residence is not a structural characteristic.

We conclude that a freestanding ADU is a separate dwelling unit and has all the structural characteristics of a dwelling unit, whether it is owned by the owner of a principal residence or not. Also in areas where residential use is allowed in rural lands, allowing a freestanding ADU with a principal residence on lots of less than ten acres creates a density of greater than one dwelling unit to five acres. Densities of greater than one dwelling unit to five acres are not rural densities. Both this [Western] Board and the Central Board have consistently said that densities of more than one unit per five acres constitute urban growth<sup>13</sup>....Therefore, allowing freestanding ADUs together with a principal residence on lots of less than ten acres in rural areas constitutes inappropriate urban growth in a rural area.

Consistent with our previous decisions, we find that [San Juan County] Ordinance 21-2002 as it pertains to internal and attached ADUs in Rural Residential designations is consistent with the GMA and fulfills the County's obligations to provide for ADUs in rural single-family neighborhoods pursuant to RCW 43.63A.215. However, we continue to find that a freestanding ADU should be considered as one dwelling unit. The effect of not counting a freestanding ADU as a dwelling unit would

---

<sup>13</sup> The Eastern Washington Growth Management Hearings Board has reached the same conclusion. "With one narrow exception, this Board has consistently found that anything under 5-acre lots is urban." *City of Moses Lake v. Grant County*, EWGMHB Case No. 99-1-0016 (Order on Remand, April 17, 2002), at 3. See also *John Diehl v. Mason County*, *supra*, at 656 (residential density of one dwelling unit per 2.5 acres is consistent with urban, not rural, development and allows for urban growth outside of the UGA in violation of GMA).

be the equivalent of permitting one dwelling unit on a lot of less than 5 acres in a rural area.

*Id.*, at 25-26.

2. Snohomish County's 2004 ADU amendments. The County's stated purpose in adopting the 2004 amendments to its ADU standards was to increase ease, flexibility and affordability of developing detached ADUs in the rural area by allowing mobile homes and exempting them from compatibility and floor area requirements. *See* 1000 Friends Motion, Ex. 2 [Index 5].<sup>14</sup> However, by crafting its manufactured housing exception for lots of 4.7 acres (200,000 square feet) or larger, rather than for lots of 10 acres (430,000 square feet) and more, the County in effect allows more than one dwelling unit per five acres, thus increasing and expanding an inconsistency with the GMA.<sup>15</sup>

Snohomish County acknowledged the risk of increased rural density and negative impact on rural character in a November 12, 2003, letter from Chief Planning Officer Linda Kruller to the Snohomish County Planning Commission. 1000 Friends Motion, Ex. 3 [Index 4]. Single-wide manufactured homes are typically larger than the 850 square foot floor area maximum allowed for detached ADUs, according to County staff. *Id.*, at 2. With manufactured homes there is less flexibility to meet the requirements for exterior compatibility with existing structures on the property. *Id.*, at 3. Affordability and faster construction timeframes will increase take-up of this housing type. *Id.*, at 2.

According to the Planning Officer:

- There is concern that the proposed amendments relaxing the size and compatibility standards for accessory apartments on 200,000 square foot or larger lots *may increase the potential for further development of rural lands*. The proposed amendments allow the use of a more affordable housing type that has a faster construction timeframe. These factors may make it easier and more appealing to develop accessory apartments on large lots. There is concern that without review for compatibility to the surrounding house type, *rural character would be modified*.
- Another concern was raised regarding the potential of the amendments to *increase rural density*. One housing unit per five acres was considered a maximum rural density by the Eastern Washington Growth Hearings

---

<sup>14</sup> The County Council made the following findings:

1. The development standards for detached accessory apartments in SCC 30.28.010 and SCC 30.91A.050 are overly restrictive as applied to residential parcels 200,000 square feet or larger

2. Allowing increased flexibility for the establishment of accessory apartments will further the Growth Management Act's affordable housing goal set forth in RCW 36.70A.020(4). . .

1000 Friends Motion, Ex. 7 [Index 28], at 4.

<sup>15</sup> The concerned citizen whose letter apparently launched the County's action lives on a 15-acre lot. Ex. 18.

Board Case, City of Moses Lake v. Grant County. Other Hearings Board orders have indicated that freestanding accessory apartments must comply with the maximum allowed density projections of comprehensive plans.... [W]ithout size restrictions, the proposed amendments may promote greater interest in developing accessory apartments as large as some existing homes in the rural area. As noted earlier, the *affordability and fast construction timeframe associated with mobile homes may increase interest in this type of development beyond the use intended* by accessory apartments. Staff has suggested that this allowance *might counteract the Countywide Planning Policies* and General Policy Plan policies related to the reasonable measures that guide the majority of residential development to urban areas....

- It has also been suggested that the elimination of the compatibility provision in SCC 30.28.010(5) on 200,000 square foot or larger lots allowed by the proposed amendment in SCC 30.28.010(11) *might hinder the protection of rural character*. Protection of the visual landscapes and compatibility is important in rural areas and is required under the Growth Management Act and the comprehensive plan General Policy Plan Goals.

*Id.*, at 2-3 (*emphasis supplied*).

In these three paragraphs the County planning staff succinctly posed the GMA concerns created by adding manufactured housing as an allowable new freestanding ADU on rural lots of less than 10 acres: the amendment increases development of rural lands, thereby modifying rural character through increased density, increased size of rural dwellings, faster and cheaper development, lack of visual and compatibility standards, and incompatibility with County Comprehensive plan policies directing growth to urban areas.

How did the County planners propose to solve these GMA concerns?

Staff proposed revisions to the draft ordinance (1) requiring that a manufactured-home ADU be “subordinate” to and smaller than the primary existing home and (2) requiring screening (i.e., landscaping) to address compatibility issues. Ex 3 [Index 4], at 3. Under the 2002 ADU provisions, detached ADUs were strictly controlled for size and compatibility. An “Accessory Apartment – Detached” could not exceed “40 percent of the floor area of the single family dwelling unit to which it is accessory, or 850 square feet, whichever is less.” Ex. 1, Table, SCC 30.28.010(1). In the amended version of SCC 30.28.010, a “mobile home” constructed as an “Accessory Department – Detached” can exceed that size so long as its floor plan is less than the primary existing home. As the Petitioners note, under this ordinance two essentially equivalent freestanding structures could be built on a rural lot of less than five acres. 1000 Friends PHB, at 22.



County staff proposed that screening requirements and neighborhood compatibility would be addressed through administrative conditional review as set forth in SCC 30.43A.100. County Response, at 20-22, Ex. D. In the conditional review process a permit may only be issued if the application complies with the comprehensive plan and is compatible with the subject property and the immediate vicinity. *Id.* However, the conditional review provisions are broadly general, with no criteria specific to protection of rural character.

The final adopted Ordinance 04-021 incorporated the revisions proposed by the planning staff. 1000 Friends Motion, Ex. 7 [Index 28].

The Board finds that the staff proposals and the Ordinance as adopted fail to “reduce the inappropriate conversion of rural land into low density development.”<sup>16</sup> RCW 36.70A.020(2). Manufactured-home ADUs as freestanding new structures on lots of less than 10 acres create a density of more than one unit in five acres. The Board finds nothing in the subordination requirement or the conditional use process to persuade it to abandon its established precedents. As the Board stated in *PNA II*, “Regardless of the size of the rural lot, ADUs attached to the main residence or a conversion of a detached existing structure (e.g., a garage) in close association with the primary residence would not constitute new urban growth.” *Id.*, at 22. However, by adding manufactured homes on lots of less than 10 acres, the County permits a growth level in rural areas that the Growth Management Hearings Boards have consistently found to constitute sprawl.

### **Conclusion**

The Board finds that Ordinance 04-21, amending the County’s development standards for ADUs, **fails to comply** with the Growth Management Act’s requirement to protect rural lands and rural character [RCW 36.70A.070(5)], so far as the amendments add manufactured homes as allowable freestanding ADUs on lots smaller than 10 acres. The Board therefore **remands** this matter to Snohomish County.

### **B. LEGAL ISSUE NO. 2**

The Board’s PHO set forth Legal Issue No. 2:

*Legal Issue #2: Does adoption of Ordinance 04-021 substantially interfere with the goals of the Growth Management Act?*

### **Applicable Law and Discussion**

RCW 36.70A.302(1)(b) does not authorize the Board to make a determination of invalidity unless it is convinced that the continued validity of a comprehensive plan or

---

<sup>16</sup> The record does not indicate whether the County considered solving GMA concerns by revising the draft ordinance to apply the manufactured home exception to lots of 10 acres or more.

development regulation would substantially interfere with the fulfillment of the Act's goals.

The County's record contains no information concerning the number or extent of rural lots subject to the amended development standard; the number or estimate of existing ADUs in the rural area, attached or detached; or the anticipated increase in rural ADU development likely to result from the allowance for manufactured homes. The County points to a one-page checklist that characterizes the likely impact on overall housing capacity in the entire county as "insignificant," County Response, at 19<sup>17</sup>, in contrast to the staff report that discussed the possibility of increased rural development. 1000 Friends Motion, Ex. 3 [Index 4].

1000 Friends, for its part, argues that the case must be decided as a matter of law, based on controlling Board precedents. Petitioner therefore has supplied no numbers, either to this Board or in its submission to the County Council,<sup>18</sup> that demonstrate penetration rates of ADUs in rural areas, whether attached or detached, stick-built or manufactured. Petitioners have placed no facts in the record indicating that new manufactured-home ADUs are likely to be constructed on lots of less than 10 acres in significant numbers in the interim, degrading rural character, before the County can bring its regulations into compliance.

On this point, the present case is in sharp contrast to *San Juan, supra*, where the record included a detailed analysis of ADU utilization. On those facts, the Western Board found substantial interference with Goal 2 of the GMA and entered an order of invalidity.

### **Conclusion**

Given the recode before the Board, the Board **declines** to enter a determination of invalidity.

---

<sup>17</sup> Index 13, "Analysis of Building and Land Use Regulation Effects on Housing and Jobs," which concludes, "since accessory apartments account for a very insignificant portion of the county's housing starts, the proposal will not contribute significantly to overall housing capacity."

<sup>18</sup> 1000 Friends Motion, Ex. 6.

## VI. ORDER

Based upon review of Ordinance 04-021, the County's code provisions, the GMA, case law, prior Orders of this Board and the other Boards, the PFR, the briefs and exhibits submitted by the parties, having considered the arguments of the parties, and having deliberated on the matter, the Board ORDERS:

1. Snohomish County's adoption of Ordinance 04-021 was **clearly erroneous** in amending the County's development regulations to expand provisions for new freestanding ADUs on rural lots of less than 10 acres.

2. The Board **remands** Ordinance 04-021 to the County with direction to take appropriate legislative action to bring the challenged portion of the legislation into compliance with the goals and requirements of the Act. The remand period extends until the Board finds compliance.

3. The Board sets the following Compliance Schedule:

- By no later than **March 14, 2005**, the County shall take appropriate legislative action to bring the challenged portion of its ADU regulations into compliance with the goals and requirements of the GMA as interpreted and set forth in this Final Decision and Order (**FDO**).
- By no later than **March 21, 2005**, the County shall file with the Board an original and four copies of a Statement of Actions Taken to Comply (**SATC**) with the GMA, as interpreted and set forth in this FDO. The SATC shall attach copies of legislation enacted in order to comply and may indicate what portions of the legislation respond to the issues laid out in the FDO. The County shall simultaneously serve a copy of the SATC, with attachments, on Petitioner. By this same date, the County shall file a **Remand Index**, listing the procedures and materials considered in taking the remand action.
- By no later than **March 28, 2005**, the Petitioner may file with the Board an original and four copies of Comments on the County's SATC. Petitioner shall simultaneously serve a copy of its Comments on the County.
- By no later than **April 4, 2005**, the County may file with the Board an original and four copies of the County's Reply to Comments. The County shall simultaneously serve a copy of such Reply on Petitioner.

Pursuant to RCW 36.70A.330(1), the Board hereby schedules the **Compliance Hearing** in this matter for **2:00 p.m. April 18, 2005** at the Board's offices. If the parties so stipulate, the Board will consider conducting the compliance hearing telephonically. If the County takes legislative compliance actions prior to the March 14, 2005 deadline set

forth in this Order, it may file a motion with the Board requesting an adjustment to this compliance schedule.

So ORDERED this 13<sup>th</sup> day of December 2004.

CENTRAL PUGET SOUND GROWTH MANAGEMENT HEARINGS BOARD

---

Edward G. McGuire, AICP  
Board Member

---

Bruce C. Laing, FAICP  
Board Member

---

Margaret A. Pageler  
Board Member

Note: This order constitutes a final order as specified by RCW 36.70A.300 unless a party files a motion for reconsideration pursuant to WAC 242-02-832.

## APPENDIX A

### PROCEDURAL BACKGROUND

#### A. GENERAL

On June 14, 2004, the Central Puget Sound Growth Management Hearings Board (the **Board**) received a Petition for Review (**PFR**) from 1000 Friends of Washington (**1000 Friends** or **Petitioners**). The matter was assigned Case No. 04-3-0018 and is hereafter referred to as *1000 Friends IV*. Board Member Margaret Pageler was the Presiding Officer (**PO**) for this matter. Petitioner challenges Snohomish County's (**Respondent** or **County**) adoption of Ordinance 04-021 amending Snohomish County's development regulations concerning accessory dwelling apartments (**ADUs**). The basis for the challenge is noncompliance with the Growth Management Act (**GMA** or the **Act**) in amendments concerning ADUs in the rural area.

On July 16, 2004, the Board received a Notice of Association of Counsel associating Kenneth L. Lederman and the law firm of Riddell Williams P.S. as co-counsel for Petitioner in this action.

On June 17, 2004, the Board issued a Notice of Hearing; on July 19, 2004, the Board held the Prehearing Conference; and on July 21, 2004, the Board issued a Prehearing Order (**PHO**) setting the schedule and legal issues for this case.

On July 19, 2004, the Board received Snohomish County's Index to the Record.

#### B. DISPOSITIVE MOTIONS

On August 3, 2004, the Board received Snohomish County's Motion to Dismiss (**County Motion**) with five attachments and Petitioner's Motion for Summary Judgment (**1000 Friends Motion**) with seven attachments. Later on August 3, 2004, the Board received Snohomish County's Expedited Motion to Strike Petitioner's Motion for Summary Judgment. On August 4, 2004, the Board received the Response Memorandum of 1000 Friends of Washington in Opposition to Expedited Motion to Strike.

On August 4, 2004, the Board held a telephone conference with the parties to hear argument on the motion to strike. On August 6, 2004, the Board issued its Order on Motions, suspending the motions calendar in this case and dismissing the dispositive motions of both parties without prejudice.

#### C. BRIEFING AND HEARING ON THE MERITS

On September 13, 2004, the Board received the Prehearing Brief of 1000 Friends of Washington (**1000 Friends PHB**). On October 5, 2004, the Board received Snohomish County's Motion to Dismiss and Prehearing Brief (**County Response**).

On October 7, 2004, the Board received a Stipulation to Continue Briefing Schedule, submitted jointly by Petitioner and Respondent, requesting the Board to excuse the tardy filing of the County Response as a legal messenger's error and to extend the briefing schedule by one day.

On October 11, 2004, the Board issued its Order Continuing Briefing Schedule.

On October 12, 2004, the Board received the Reply Brief of 1000 Friends of Washington (**1000 Friends Reply**).

On November 1, 2004, the Board held a Hearing on the Merits (**HOM**) at the Board's offices in Suite 2470, 900 Fourth Avenue, Seattle, Washington. Board Members Margaret A. Pageler, Presiding Officer, Edward G. McGuire, and Bruce C. Laing were present for the Board. Petitioner was represented by Ken Lederman of Riddell Williams, P.S. Respondent was represented by Snohomish County Deputy Prosecuting Attorney Jason Cummings. Board externs Julie Taylor and Jessica Clawson also attended. Court reporting services were provided by J. Gayle Hays, of Byers and Anderson, Inc. The hearing convened at 10:00 a.m. and adjourned at approximately 11:00 a.m. The Board did not order a transcript of the HOM.

**18A.37.120 Accessory Dwelling Unit (ADU).**

- A. The establishment of an ADU shall be subject to the following general requirements:
  - 1. One ADU shall be allowed per lot of record as an accessory use in conjunction with any detached single-family structure in all zones. ADUs shall not be permitted on lots created under Chapter 18J.17 PCC, Small Lot Design. ADUs shall not be included in density calculations.
  - 2. An ADU shall be converted to another permitted use or shall be removed if one of the two dwelling units is not owner occupied.
  - 3. An ADU shall be permitted as a second dwelling unit attached to, or detached from, the principal dwelling.
  - 4. A detached ADU may be any dwelling permitted in the applicable land use classification.
  - 5. New construction of a detached ADU or conversion of an existing detached structure to an ADU shall not be permitted within the required front, side, or rear yard setback. An exception to the required rear yard setback may be allowed if the rear yard abuts an alley.
  - 6. If an ADU is created by constructing a new detached structure, the building height of the ADU shall not be greater than the principal dwelling's building height, unless the ADU is above a detached garage.
- B. **Size.** An ADU shall be no greater than 1,000 square feet when located in an Urban Growth Area. When located outside an Urban Growth Area, the size may increase to 1,250 square feet.
  - 1. The following areas shall be counted when calculating the size of an ADU: any area with a ceiling height of 7 feet or more; all bathroom and basement areas with a ceiling height of 6 feet, 8 inches or more; and any areas with sloped ceilings where 50 percent of said area has a ceiling height of 5 feet or more.
  - 2. When calculating the square footage of an attached ADU, all measurements shall be taken from the interior walls.
  - 3. When calculating the square footage of a detached ADU, all measurements shall be taken from the exterior walls and shall include each level of the structure, excluding only the garage, covered porches, and any levels not accessed by a permanent stairway structure.
- C. **Design.** The following standards shall apply when the separation between the principal dwelling and proposed accessory dwelling is less than 100 linear feet:
  - 1. The entrance to an attached ADU shall not be directed toward any front yard unless utilizing an existing doorway.
  - 2. Detached ADUs shall be no closer to the front lot line than the front edge of the principal dwelling. This provision shall not apply to waterfront lots regulated pursuant to Title 18S PCC, Development Policies and Regulations – Shorelines.
  - 3. **Parking.** One off-street parking space shall be required for the ADU in addition to

off-street parking required for the principal dwelling pursuant to PCC 18A.35.040, Off-Street Parking.

- D. **Application.** Any owner occupant seeking to establish an ADU shall apply for approval in accordance with established procedures. These procedures shall include:
1. The owner occupant shall apply for a Building Permit for an ADU. A complete application form must demonstrate that all size thresholds and design standards are met.
  2. An affidavit affirming that the owner will occupy the principal dwelling or the ADU and agreeing to all the general requirements as provided in this Section is required.
  3. Prior to issuance of Building Permits, the owner occupant shall record a notice on the property title acknowledging the existence of the ADU with the Pierce County Auditor. Such notice shall be in a form as specified by the Department and shall include as a minimum:
    - a. The legal description of the property which has been approved for an ADU;
    - b. The applicability of the restrictions and limitations contained in this Section;
    - c. A copy of the County-approved floor/site plan; and
    - d. The property owner's signature on the notice, which shall be notarized prior to recording the notice.

(Ord. 2016-33 § 2 (part), 2016; Ord. 2016-14s § 2 (part), 2016; Ord. 2013-45s4 § 3 (part), 2015)



# Accessory Dwelling Units

Index # - File Name: 1.0015 - Other Codes Tracking Sheet.pdf

	Date Retrieved	Def'n	Type of Use			Density Language	Size	Number per Lot	Parking	Design Standards	Entrance	Occupancy	Weblink
			Urban	Rural	Resource								
King County	6/21/2019, 9/11/2019	<b>21A.06.350: Dwelling unit, Accessory.</b> a separate, complete dwelling unit attached to or contained within the structure of the primary dwelling; or contained within a separate structure that is accessory to the primary dwelling unit on the premises	p	p	p	(b) If one transferable development right is purchased from the Rural Area or Natural Resource Lands under K.C.C. chapter 21A.37, a detached accessory dwelling unit is allowed on an RA-5 zoned lot that is at least two and one-half acres and less than three and three-quarters acres;	up to 1000 sq feet	1 per single detached dwelling unit	1 off street parking spot		One entrance per street	ADU of primary dwelling shall be owner occupied.	<a href="https://kingcounty.gov/council/legislation/kc_code.aspx">https://kingcounty.gov/council/legislation/kc_code.aspx</a>
Pierce County	6/21/2019, 9/11/2019	a second dwelling unit added to, created within, or detached from a single-family detached dwelling for use as a completely independent or semi-independent unit with provisions for cooking, eating, sanitation, and sleeping.	Accessory	Accessory	Accessory	1. One ADU shall be allowed per lot of record as an accessory use in conjunction with any detached single-family structure in all zones. ADUs shall not be permitted on lots created under Chapter 18J.17 PCC, Small Lot Design. <b>ADUs shall not be included in density calculations.</b>	Up to 1000 in UGA; up to 1250 outside UGA	1 per lot of record	1 off street parking spot	Only apply if is less than 100 linear feet away from the primary dwelling.		ADU or primary dwelling shall be owner occupied.	<a href="https://www.codepublishing.com/WA/PierceCounty/#!/PierceCountyNT.html">https://www.codepublishing.com/WA/PierceCounty/#!/PierceCountyNT.html</a>
Skagit County	6/21/2019, 9/11/2019	separate living quarters located on the same lot and either detached from or included within a primary residence. No recreational vehicle shall be allowed as an accessory dwelling unit.	Accessory	Accessory	Accessory	One accessory dwelling unit is permitted as accessory to an existing single-family dwelling; provided, that the following requirements are met, except as may be further restricted by the connection limitation in SCC <a href="#">14.16.920</a> , Similk Beach LAMIRD	Up to 900 or 50% of the primary dwelling	1 per existing single-family dwelling	3 off street spaces for the combination of the ADU and primary dwelling		No more than 1 entrance visible from the street	ADU or primary dwelling shall be occupied by the owner or an immediate family member.	<a href="https://www.codepublishing.com/WA/SkagitCounty/">https://www.codepublishing.com/WA/SkagitCounty/</a>
Whatcom County	6/21/2019, 9/11/2019	<b>"Detached accessory dwelling unit"</b> means a separate and complete dwelling unit not attached in any way to the main or existing dwelling unit; designed for occupancy by a family. (Ord. 94-002, 1994).	Accessory	Accessory	Accessory	(10) Outside of an urban growth area, the minimum lot size for detached accessory units shall be on a lot of record no less than 4.5 acres, unless the parcel is large enough to accommodate two dwelling units consistent with the underlying zoning density	up to 1248	1 per lot			No more than 1 entrance visible from the street	ADU or primary dwelling shall be owner occupied.	<a href="https://www.codepublishing.com/WA/WhatcomCounty/">https://www.codepublishing.com/WA/WhatcomCounty/</a>

**CITY OF SEATTLE**

**ORDINANCE \_\_\_\_\_**

**COUNCIL BILL \_\_\_\_\_**

..title

AN ORDINANCE relating to land use and zoning, amending Sections 23.44.011, 23.44.014, 23.44.017, 23.44.020, 23.44.041, 23.45.545, 23.84A.002, 23.84A.032, 23.84A.038, and 23.86.007 of the Seattle Municipal Code to remove barriers to the creation of attached and detached accessory dwelling units and add a floor area ratio requirement in certain single-family zones.

..body

WHEREAS, the City Council adopted Resolution 31547 in September 2014, directing the Department of Planning and Development to explore policy changes that would increase the production of attached accessory dwelling units and detached accessory dwelling units, including regulatory changes, incentives, marketing, and promotion; and

WHEREAS, the Housing Affordability and Livability Agenda (HALA) Advisory Committee made recommendations in July 2015 to the Mayor and City Council, including Recommendation SF.1a to remove code barriers to accessory dwelling units and backyard cottages by removing the parking requirement, removing the owner-occupancy requirement, allowing a single lot to have both an attached and detached accessory dwelling unit, and making minor modifications to existing development standards for detached accessory dwelling units; and

WHEREAS, the City Council adopted Resolution 31609 in September 2015, declaring its intent to consider strategies to increase the availability of affordable housing in Seattle, outlining an overarching policy framework and timeline for the Mayor’s HALA recommendations, and establishing the Council Work Plan for HALA Recommendations, which included Strategy (h) to remove barriers to the development of detached and attached accessory dwelling units; and

1 WHEREAS, attached accessory dwelling units have been allowed on single-family lots since  
2 1994, and detached accessory dwelling units have been allowed on single-family lots  
3 since 2010, subject to certain development standards; and

4 WHEREAS, since 2010 only approximately 700 detached accessory dwelling units have been  
5 constructed, accounting for less than one percent of eligible single-family lots;  
6 NOW, THEREFORE,

7 **BE IT ORDAINED BY THE CITY OF SEATTLE AS FOLLOWS:**

8 Section 1. Section 23.44.011 of the Seattle Municipal Code, enacted by Ordinance  
9 125791, is amended as follows:

10 **23.44.011 Floor area in ((RSL)) single-family zones**

11 A. Gross floor area. In ((RSL)) single-family zones, gross floor area includes exterior  
12 corridors, breezeways, and stairways that provide building circulation and access to dwelling  
13 units or sleeping rooms. Balconies, patios, and decks that are associated with a single dwelling  
14 unit or sleeping room and that are not used for common circulation, and ground-level walking  
15 paths, are not considered gross floor area.

16 B. Floor area ratio (FAR) limits.

17 1. The FAR limit on lots developed with a single-family dwelling unit as the  
18 principal use in SF 5000, SF 7200, and SF 9600 zones, is 0.5, except that lots with less than  
19 5,000 square feet of lot area can include up to 2,500 square feet of total chargeable floor area.

20 The applicable FAR limit applies to the total chargeable floor area of all structures on the lot.

21 2. The FAR limit in RSL zones is 0.75. The applicable FAR limit applies to  
22 the total chargeable floor area of all structures on the lot.

1 C. The following floor area is exempt from FAR limits:  
2 1. All stories, or portions of stories, that are underground.  
3 2. All portions of a story that extend no more than 4 feet above existing or  
4 finished grade, whichever is lower, excluding access.

5 3. In SF 5000, SF 7200, and SF 9600 zones:  
6 a. Any floor area contained in an accessory dwelling unit;  
7 b. Either up to 500 additional square feet of floor area in any  
8 accessory structure that is not a detached accessory dwelling unit, or up to 250 square feet of  
9 floor area in an attached garage.

10 ~~((3))~~ 4. ~~((Fifty))~~ In RSL zones, 50 percent of floor area contained in  
11 structures built prior to January 1, 1982, as single-family dwelling units that will remain in  
12 residential use, regardless of the number of dwelling units within the existing structure, provided  
13 the exemption is limited to the gross square footage in the single-family dwelling unit as of  
14 January 1, 1982.

15 D. In SF 5000, SF 7200, and SF 9600 zones, additions to a single-family dwelling  
16 unit existing on the effective date of the ordinance introduced as Council Bill 119544 may  
17 exceed the FAR limit in subsection 23.44.011.B.1 if the addition adds floor area equal to or less  
18 than 20 percent of the floor area that existed on the effective date of the ordinance introduced as  
19 Council Bill 119544. Only one addition to any single-family dwelling unit may be exempted  
20 under this subsection 23.44.011.D.

21 Section 2. Section 23.44.014 of the Seattle Municipal Code, last amended by Ordinance  
22 125791, is amended as follows:

23 **23.44.014 Yards and separations**

1 \* \* \*

2 C. Exceptions from standard yard requirements. No structure shall be placed in a  
3 required yard except as follows:

4 1. Garages. Garages may be located in a required yard subject to the  
5 standards of Section 23.44.016.

6 2. Certain accessory structures in side and rear yards

7 a. Except for detached accessory dwelling units, any accessory  
8 structure that complies with the requirements of Section 23.44.040 may be constructed in a side  
9 yard that abuts the rear or side yard of another lot, or in that portion of the rear yard of a reversed  
10 corner lot within 5 feet of the key lot and not abutting the front yard of the key lot, upon  
11 recording with the King County Recorder's Office an agreement to this effect between the  
12 owners of record of the abutting properties.

13 b. Except for detached accessory dwelling units, any detached  
14 accessory structure that complies with the requirements of Section 23.44.040 may be located in a  
15 rear yard, provided that on a reversed corner lot, no accessory structure shall be located in that  
16 portion of the required rear yard that abuts the required front yard of the adjoining key lot, nor  
17 shall the accessory structure be located closer than 5 feet from the key lot's side lot line unless  
18 the provisions of subsections 23.44.014.C.2.a or 23.44.016.D.9 apply.

19 c. A detached accessory dwelling unit may be located in a rear yard  
20 subject to the requirements of subsection 23.44.041.C.

21 3. A principal residential structure or a detached accessory dwelling unit may  
22 extend into one side yard if an easement is provided along the side or rear lot line of the abutting  
23 lot, sufficient to leave a 10-foot separation between that structure and any principal structure or

1 detached accessory dwelling unit on the abutting lot. The 10-foot separation shall be measured  
2 from the wall of the principal structure or the wall of the detached accessory dwelling unit that is  
3 proposed to extend into a side yard to the wall of the principal structure or detached accessory  
4 dwelling unit on the abutting lot.

5 a. No structure or portion of a structure may be built on either lot  
6 within the 10-foot separation, except as provided in this Section 23.44.014.

7 b. Accessory structures, other than detached accessory dwelling units,  
8 and features of and projections from principal structures, such as porches, eaves, and chimneys,  
9 are permitted in the 10-foot separation area required by this subsection 23.44.014.C.3 if  
10 otherwise allowed in side yards by this subsection 23.44.014.C. For purposes of calculating the  
11 distance a structure or feature may project into the 10-foot separation, assume the property line is  
12 5 feet from the wall of the principal structure proposed to extend into a side yard and consider  
13 the 5 feet between the wall and the assumed property line to be the required side yard.

14 c. No portion of any structure, including any projection, shall cross  
15 the property line.

16 d. The easement shall be recorded with the King County Recorder's  
17 Office. The easement shall provide access for normal maintenance activities to the principal  
18 structure on the lot with less than the required (~~5-foot~~) 5-foot side yard.

19 4. Certain additions. Certain additions to an existing single-family structure,  
20 or an existing accessory structure if being converted to a detached accessory dwelling unit may  
21 extend into a required yard if the existing single-family structure is already nonconforming with  
22 respect to that yard. The presently nonconforming portion must be at least 60 percent of the total  
23 width of the respective facade of the structure prior to the addition. The line formed by the

1 existing nonconforming wall of the structure is the limit to which any additions may be built,  
2 except as described in subsections 23.44.014.C.4.a through 23.44.014.C.4.e. Additions may  
3 extend up to the height limit and may include basement additions. New additions to the  
4 nonconforming wall or walls shall comply with the following requirements (Exhibit A for  
5 23.44.014):

6 a. Side yard. If the addition is a side wall, the existing wall line may  
7 be continued by the addition except that in no case shall the addition be closer than 3 feet to the  
8 side lot line;

9 b. Rear yard. If the addition is a rear wall, the existing wall line may  
10 be continued by the addition except that in no case shall the addition be closer than 20 feet to the  
11 rear lot line or centerline of an alley abutting the rear lot line;

12 c. Front yard. If the addition is a front wall, the existing wall line may  
13 be continued by the addition except that in no case shall the addition be closer than 15 feet to the  
14 front lot line;

15 d. If the nonconforming wall of the single-family structure is not  
16 parallel or is otherwise irregular, relative to the lot line, then the Director shall determine the  
17 limit of the wall extension, except that the wall extension shall not be located closer than  
18 specified in subsections 23.44.014.C.4.a, 23.44.014.C.4.b, and 23.44.014.C.4.c.

19 e. Roof eaves, gutters, and chimneys on such additions may extend  
20 an additional 18 inches into a required yard, but in no case shall such features be closer than 2  
21 feet to the side lot line.

1 **Exhibit A for 23.44.014**  
2 **Additions into yards for existing single-family structures**

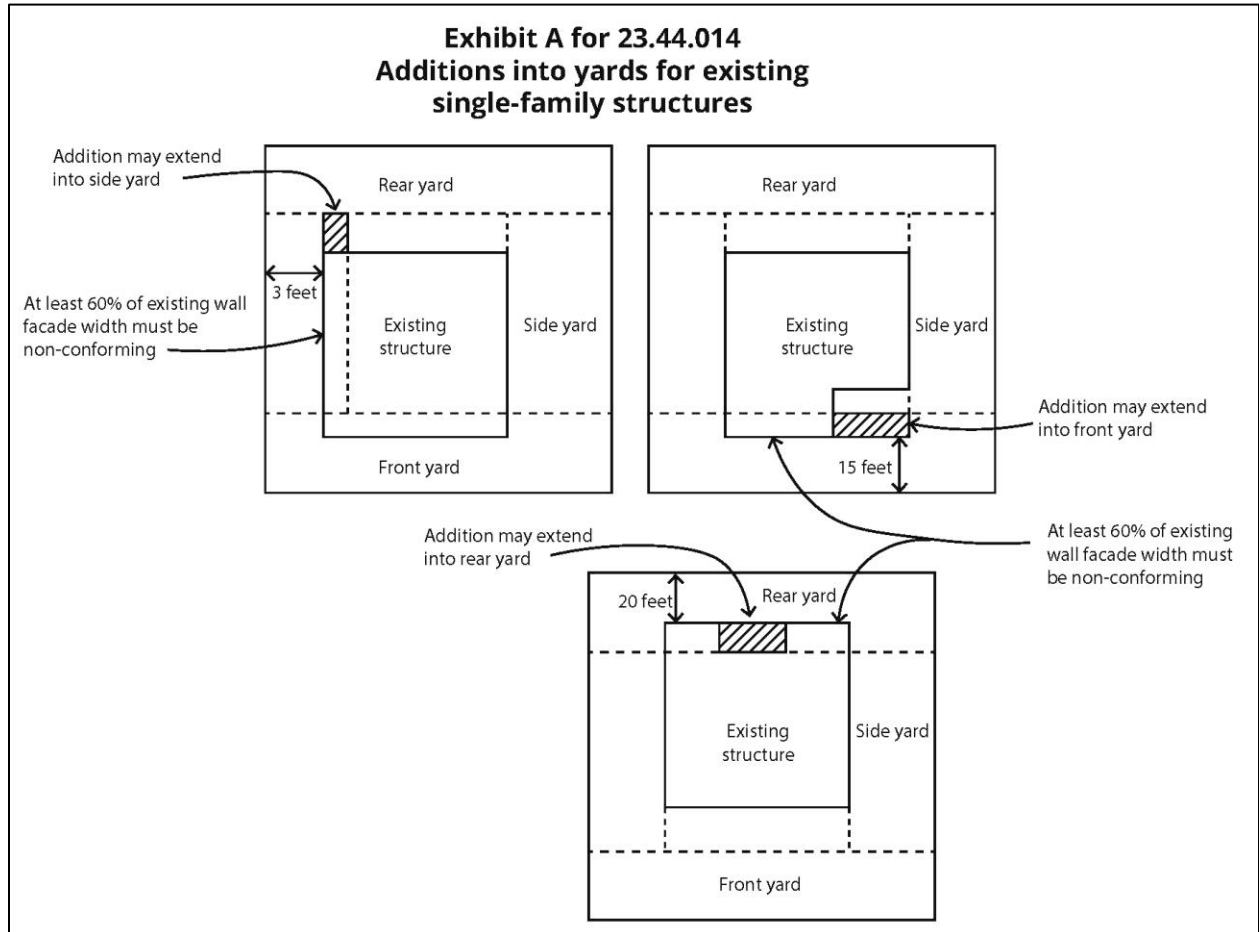

3  
4 5. Uncovered porches or steps. Uncovered, unenclosed porches ((=)) or steps  
5 may project into any required yard, if each component is no higher than 4 feet above existing  
6 grade, no closer than 3 feet to any side lot line, and has no horizontal distance greater than 6 feet  
7 within the required yard. For each entry to a principal structure, one uncovered, unenclosed  
8 porch and/or associated steps are permitted in the required yards.

9 6. Certain features of a structure. Unless otherwise provided elsewhere in  
10 this Chapter 23.44, certain features of a principal or accessory structure, except for accessory  
11 dwelling units, may extend into required yards if they comply with the following:



1 a. External architectural details with no living area, such as  
2 chimneys, eaves, cornices, and columns, may project no more than 18 inches into any required  
3 yard;

4 b. Bay windows are limited to 8 feet in width and may project no  
5 more than 2 feet into a required front, rear, and street side yard;

6 c. Other projections that include interior space, such as garden  
7 windows, may extend no more than 18 inches into any required yard, starting a minimum of 30  
8 inches above finished floor, and with maximum dimensions of 6 feet in height and 8 feet in  
9 width;

10 d. The combined area of features permitted by subsections  
11 23.44.014.C.6.b and 23.44.014.C.6.c may comprise no more than 30 percent of the area of the  
12 facade.

13 7. Covered unenclosed decks and roofs over patios. Covered, unenclosed  
14 decks and roofs over patios, if attached to a principal structure or a detached accessory dwelling  
15 unit, may extend into the required rear yard, but shall not be within 12 feet of the centerline of  
16 any alley, or within 12 feet of any rear lot line that is not an alley lot line, or closer to any side lot  
17 line in the required rear yard than the side yard requirement of the principal structure along that  
18 side, or closer than 5 feet to any accessory structure. The height of the roof over unenclosed  
19 decks and patios shall not exceed 12 feet. The roof over such decks or patios shall not be used as  
20 a deck.

21 8. Access bridges. Uncovered, unenclosed access bridges are permitted as  
22 follows:

1                           a.       Pedestrian bridges 5 feet or less in width, and of any height  
2 necessary for access, are permitted in required yards, except that in side yards an access bridge  
3 must be at least 3 feet from any side lot line.

4                           b.       A driveway access bridge is permitted in the required yard abutting  
5 the street if necessary for access to parking. The vehicular access bridge shall be no wider than  
6 12 feet for access to one parking space or 18 feet for access to two or more parking spaces and of  
7 any height necessary for access. The driveway access bridge may not be located closer than 5  
8 feet to an adjacent property line.

9                           9.       Barrier-free access. Access facilities for the disabled and elderly that  
10 comply with Washington State Building Code ((-)) Chapter 11 are permitted in any required  
11 yard.

12                          10.       Freestanding structures and bulkheads

13                           a.       Fences, freestanding walls, bulkheads, signs, and similar structures  
14 6 feet or less in height above existing or finished grade, whichever is lower, may be erected in  
15 any required yard. The 6-foot height may be averaged along sloping grade for each 6-foot-long  
16 segment of the fence, but in no case may any portion of the fence exceed 8 feet. Architectural  
17 features may be added to the top of the fence or freestanding wall above the 6-foot height if the  
18 features comply with the following: horizontal architectural feature(s), no more than 10 inches  
19 high, and separated by a minimum of 6 inches of open area, measured vertically from the top of  
20 the fence, are permitted if the overall height of all parts of the structure, including post caps, is  
21 no more than 8 feet. Averaging the 8-foot height is not permitted. Structural supports for the  
22 horizontal architectural feature(s) may be spaced no closer than 3 feet on center.

1                           b.       The Director may allow variation from the development standards  
2 listed in subsection 23.44.014.C.10.a, according to the following:

3                                           1)       No part of the structure may exceed 8 feet; and

4                                           2)       Any portion of the structure above 6 feet shall be

5 predominately open, such that there is free circulation of light and air.

6                           c.       Bulkheads and retaining walls used to raise grade may be placed in  
7 any required yard when limited to 6 feet in height, measured above existing grade. A guardrail  
8 no higher than 42 inches may be placed on top of a bulkhead or retaining wall existing as of  
9 February 20, 1982. If a fence is placed on top of a new bulkhead or retaining wall, the maximum  
10 combined height is limited to 9 1/2 feet.

11                           d.       Bulkheads and retaining walls used to protect a cut into existing  
12 grade may be placed in any required yard when limited to the minimum height necessary to  
13 support the cut. If the bulkhead or retaining wall is measured from the low side and it exceeds 6  
14 feet, an open guardrail of no more than 42 inches meeting Building Code requirements may be  
15 placed on top of the bulkhead or retaining wall. If the bulkhead or retaining wall is 6 feet or less,  
16 a fence may be placed on top up to a maximum combined height of 9.5 feet for both fence and  
17 bulkhead or retaining wall.

18                           e.       If located in shoreline setbacks or in view corridors in the  
19 Shoreline District as regulated in Chapter 23.60A, structures shall not obscure views protected  
20 by Chapter 23.60A, and the Director shall determine the permitted height.

21                           11.       Decks in yards. Decks no higher than 18 inches above existing or finished  
22 grade, whichever is lower, may extend into required yards.

1                   12.     Mechanical equipment. Heat pumps and similar mechanical equipment,  
2 not including incinerators, are permitted in required yards if they comply with the requirements  
3 of Chapter 25.08. Any heat pump or similar equipment shall not be located within 3 feet of any  
4 lot line. Charging devices for electric cars are considered mechanical equipment and are  
5 permitted in required yards if not located within 3 feet of any lot line.

6                   13.     Solar collectors. Solar collectors may be located in required yards, subject  
7 to the provisions of Section 23.44.046.

8                   14.     Front yard projections for structures on lots 30 feet or less in width. For a  
9 structure on a lot in an SF 5000, SF 7200, or SF 9600 zone that is 30 feet or less in width,  
10 portions of the front facade that begin 8 feet or more above finished grade may project up to 4  
11 feet into the required front yard, provided that no portion of the facade, including eaves and  
12 gutters, shall be closer than 5 feet to the front lot line (Exhibit B for 23.44.014), and provided  
13 further that no portion of the facade of an existing structure that is less than 8 feet or more above  
14 finished grade already projects into the required front yard.

- 1 **Exhibit B for 23.44.014**
- 2 **Front yard projections permitted for structures on lots 30 feet or less in width**

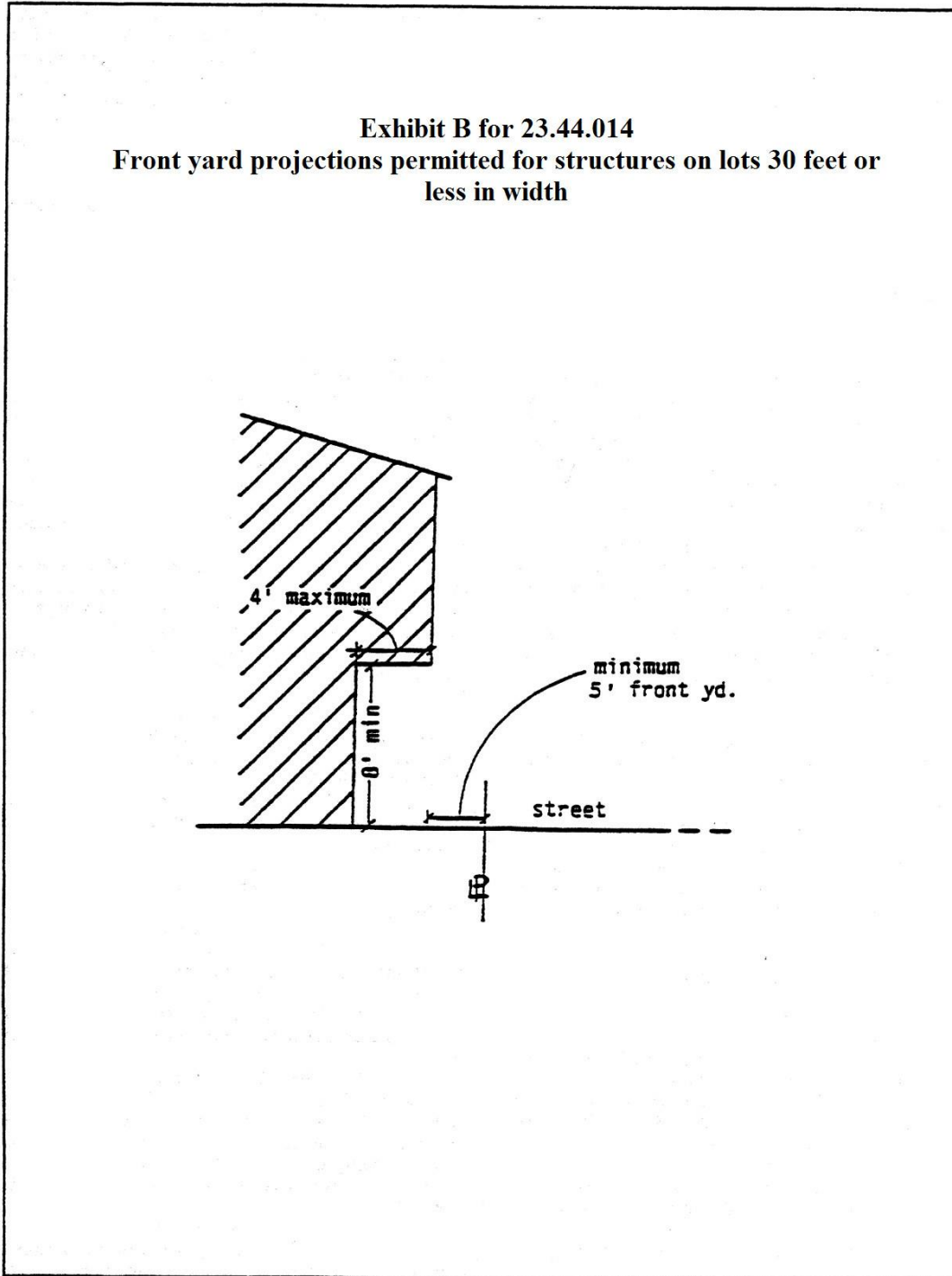

3

1                   15.     Front and rear yards may be reduced by 25 percent, but no more than 5  
2 feet, if the site contains a required environmentally critical area buffer or other area of the  
3 property that cannot be disturbed pursuant to subsection 25.09.280.A.

4                   16.     Arbors. Arbors may be permitted in required yards under the following  
5 conditions:

6                   a.       In any required yard, an arbor may be erected with no more than a  
7 40-square-foot footprint, measured on a horizontal roof plane inclusive of eaves, to a maximum  
8 height of 8 feet. Both the sides and the roof of the arbor shall be at least 50 percent open, or if  
9 latticework is used, there shall be a minimum opening of 2 inches between crosspieces.

10                  b.       In each required yard abutting a street, an arbor over a private  
11 pedestrian walkway with no more than a 30-square-foot footprint, measured on the horizontal  
12 roof plane and inclusive of eaves, may be erected to a maximum height of 8 feet. The sides of the  
13 arbor shall be at least 50 percent open, or if latticework is used, there shall be a minimum  
14 opening of 2 inches between crosspieces.

15                  17.     Stormwater management

16                  a.       Above-grade green stormwater infrastructure (GSI) features are  
17 allowed without yard restrictions if:

18                           1)     Each above-grade GSI feature is less than 4.5 feet tall,  
19 excluding piping;

20                           2)     Each above-grade GSI feature is less than 4 feet wide; and

21                           3)     The total storage capacity of all above-grade GSI features

22 is no greater than 600 gallons.

- 1                                   b.     Above-grade GSI features larger than what is allowed in  
2 subsection 23.44.014.C.17.a are allowed within a required yard if:
- 3                                   1)     Above-grade GSI features do not exceed ten percent  
4 coverage of any one yard area;
- 5                                   2)     No portion of an above-grade GSI feature is located closer  
6 than 3 feet from a side lot line;
- 7                                   3)     No portion of an above-grade GSI feature is located closer  
8 than 20 feet from a rear lot line or centerline of an alley abutting the rear lot line; and
- 9                                   4)     No portion of an above-grade GSI feature is located closer  
10 than 15 feet from the front lot line.

11                                18.     A structure may be permitted to extend into front and rear yards as  
12 necessary to protect exceptional trees and trees over 2 feet in diameter pursuant to Section  
13 25.11.060.

14                                D.     Additional standards for structures if allowed in required yards. Structures in  
15 required yards shall comply with the following:

- 16                                1.     Accessory structures, attached garages, and portions of a principal  
17 structure shall not exceed a maximum combined coverage of 40 percent of the required rear yard,  
18 except that a detached accessory dwelling unit may cover an additional 20 percent of the rear  
19 yard provided that the increased rear yard coverage does not require removal of any exceptional  
20 trees or trees over 2 feet in diameter measured 4.5 feet above the ground. In the case of a rear  
21 yard abutting an alley, rear yard coverage shall be calculated from the centerline of the alley.

Accessory Dwelling Units

1                   2.     Any accessory structure located in a required yard shall be separated from  
2 its principal structure by a minimum of 5 feet. This requirement does not apply to terraced  
3 garages that comply with subsection 23.44.016.C.9.b.

4                   3.     Except for detached accessory dwelling units, ~~((in subsection~~  
5 ~~23.44.041.B,))~~ any accessory structure located in a required yard shall meet both the following  
6 standards:

7                   a.     A maximum height of 12 feet; and

8                   b.     A maximum size of 1,000 square feet in area.

9                   4.     Any detached accessory dwelling unit located in a required yard is subject  
10 to the requirements of subsection 23.44.041.C.

11                                           \* \* \*

12                   Section 3. Section 23.44.017 of the Seattle Municipal Code, enacted by Ordinance  
13 125791, is amended as follows

14 **23.44.017 Density limits**

15                   A. In SF 5000, SF 7200, and SF 9600 zones, only one single-family dwelling unit is  
16 allowed per lot, except that ((an))up to two accessory dwelling units may also be approved  
17 pursuant to Section 23.44.041, and except as approved as part of an administrative conditional  
18 use permit under Section 25.09.260, a clustered housing planned development under Section  
19 23.44.024, or a planned residential development under Section 23.44.034.

20                                           \* \* \*

21                   Section 4. Section 23.44.020 of the Seattle Municipal Code, enacted by Ordinance  
22 125791, is amended as follows:

23 **23.44.020 Tree requirements**



1           A.     Tree requirements in SF 5000, SF 7200, and SF 9600 zones

2                    1. Trees sufficient to meet the following requirements shall be provided

3 when single-family dwelling units are constructed:

4                           a.     For lots over 3,000 square feet, at least 2 caliper inches of tree per  
5 1,000 square feet of lot area.

6                           b.     On lots that are 3,000 square feet or smaller, at least 3 caliper  
7 inches of tree.

8                    2. Trees sufficient to meet the following requirements shall be provided

9 when a new structure, or an addition to an existing structure, containing an accessory dwelling  
10 unit is constructed:

11                           a. For lots that do not contain the minimum number of caliper inches  
12 of tree required by subsection 23.44.020.A.1 at the time a permit application is submitted for any  
13 number of accessory dwelling units, at least 2 caliper inches of tree shall be planted;

14                           b. For lots that contain the minimum number of caliper inches of tree  
15 required by subsection 23.44.020.A.1 at the time a permit application is submitted for any  
16 number of accessory dwelling units, no new trees are required.

17                    ((2)) 3.     The minimum number of caliper inches of tree required may be  
18 met by preserving existing trees, planting new trees, or by a combination of preservation and  
19 planting. The preservation or planting of trees in the right-of-way may be counted, provided that  
20 they are approved by the Director of Transportation.

21                    ((3)) 4.     Submerged land shall not be included in calculating lot area for  
22 purposes of either the tree preservation option or tree planting option.

1 ((4)) 5. Tree measurements. Trees planted to meet the requirements in this  
2 subsection 23.44.020.A shall be at least 1.5 inches in diameter. The diameter of new trees shall  
3 be measured (in caliper inches) 6 inches above the ground. Existing trees shall be measured 4.5  
4 feet above the ground. When an existing tree is 3 to 10 inches in diameter, each 1 inch counts as  
5 1 inch toward meeting the tree requirements in this subsection 23.44.020.A. When an existing  
6 tree is more than 10 inches in diameter, each 1 inch of the tree that is over 10 inches shall count  
7 as 3 inches toward meeting the tree requirement.

8 ((5)) 6. Tree preservation plans. If the tree preservation option is chosen, a  
9 tree preservation plan must be submitted by a certified arborist and approved. Tree preservation  
10 plans shall provide for protection of trees during construction according to standards  
11 promulgated by the Director.

12 7. The owner of the subject lot shall ensure that the trees planted remain  
13 healthy for at least five years after inspection by the City and be responsible for replacing any  
14 trees that do not remain healthy after inspection by the City.

15 \* \* \*

16 Section 5. Section 23.44.041 of the Seattle Municipal Code, last amended by Ordinance  
17 125791, is amended as follows:

18 **23.44.041 Accessory dwelling units**

19 A. ((Accessory dwelling units, general provisions)) General provisions. The Director  
20 may authorize an accessory dwelling unit, and that dwelling unit may be used as a residence,  
21 only under the following conditions:

1                   1.     Number of accessory dwelling units allowed on a lot

2                    a.     In an SF 5000, SF 7200, or SF 9600 zone, a lot with or proposed

3 for a principal single-family dwelling unit may have (~~no more than one~~) up to two accessory

4 dwelling units, provided that the following conditions are met:

5                             1)     Only one accessory dwelling unit may be a detached

6 accessory dwelling unit; and

7                             2)     A second accessory dwelling unit is allowed only if : (1)

8 the applicant makes a commitment that the new principal structure or the new accessory structure

9 containing a detached accessory dwelling unit will meet a green building standard and shall

10 demonstrate compliance with that commitment, all in accordance with Chapter 23.58D. A

11 second accessory dwelling unit that is proposed within an existing structure does not require the

12 structure to be updated to meet the green building standard; or (2) if the second accessory

13 dwelling unit is a rental unit affordable to and reserved solely for “income-eligible households,”

14 as defined in Section 23.58A.004, and is subject to an agreement specifying the affordable

15 housing requirements under this subsection approved by the Director of Housing to ensure that

16 the housing shall serve only income-eligible households for a minimum period of 50 years. The

17 monthly rent, including basic utilities, shall not exceed 30 percent of the income limit for the

18 unit, all as determined by the Director of Housing, and the housing owner shall submit a report to

19 the Office of Housing annually that documents how the affordable housing meets the terms of

20 the recorded agreement. Prior to issuance, and as a condition to issuance, of the first building

21 permit for a project, the applicant shall execute and record a declaration in a form acceptable to

22 the Director that shall commit the applicant to satisfy the conditions to establishing a second

23 accessory dwelling unit as approved by the Director.

1                                    b.        In an RSL zone, each principal dwelling unit may have no more  
 2 than one accessory dwelling unit.

3                                    2.        In the Shoreline District, accessory dwelling units shall be as provided in  
 4 Chapter 23.60A; where allowed in the Shoreline District, they are also subject to the provisions  
 5 in this Section 23.44.041.

6                                    ~~((3.—The owner(s) of the lot shall comply with the owner occupancy  
 7 requirements of subsection 23.44.041.C.~~

8                                    4)) 3.    Any number of related persons may occupy each unit ~~((in a single family  
 9 dwelling unit))~~ on a lot with ((an)) one or more accessory dwelling units.~~((; provided that, if))~~ If  
 10 unrelated persons occupy ((either-)) any dwelling unit, the total number of persons occupying  
 11 ((both)) all dwelling units may not altogether exceed eight if there is one accessory dwelling unit  
 12 on the lot. If two accessory dwelling units exist on the lot, the total number of unrelated persons  
 13 occupying all units may not altogether exceed 12.

14                                    ~~((5.—All accessory dwelling units are required to meet the development  
 15 standards in Table A for 23.44.041, unless modified in subsection 23.44.041.B:~~

<b>Table A for 23.44.041 Development standards for all accessory dwelling units</b>	
a. Maximum gross floor area	<del>Attached accessory dwelling units are limited to 1,000 square feet, including garage and storage area.<sup>1</sup> Detached accessory dwelling units are limited to 800 square feet, including any garage and storage area provided in the same structure as the accessory dwelling unit, but excluding areas below grade, measured as set forth in Section 23.86.007.</del>
b. Entrances	<del>In SF 5000, SF 7200, and SF 9600 zones, only one entrance to the structure may be located on each street-facing facade of the dwelling unit.<sup>2</sup></del>
Footnotes to Table A for 23.44.041: <sup>1</sup> The gross floor area of an attached accessory dwelling unit may exceed 1,000 square feet only if the portion of the structure in which the accessory dwelling unit is located was in existence as of June 1, 1999, and if the entire accessory dwelling unit is located on one level, except that a garage for the accessory dwelling unit may be located on a different level. <sup>2</sup> More than one entrance may be allowed if: a) two entrances on the street-facing facade	

**Table A for 23.44.041  
Development standards for all accessory dwelling units**

~~existed on January 1, 1993; or b) the Director determines that topography, screening, or another design solution is effective in de-emphasizing the presence of a second entrance.))~~

1                   4.       In an SF 5000, SF 7200, or SF 9600 zone, accessory dwelling units are  
2 subject to the tree requirements in subsection 23.44.020.A.2.

3                   ~~((6)) 5.       ((Except on lots located within areas that are defined as either an~~  
4 ~~urban center or urban village in the City’s Comprehensive Plan, one off street parking space is~~  
5 ~~required for the accessory dwelling unit and may be provided as tandem parking with the parking~~  
6 ~~space provided for the principal dwelling unit.))~~ No off-street parking is required for accessory

7 dwelling units. An existing required parking space may not be eliminated to accommodate an  
8 accessory dwelling unit unless it is replaced elsewhere on the lot. ~~((Except for lots located in~~  
9 ~~either Map A for 23.54.015, University District Parking Impact Area, or Map B for 23.54.015,~~  
10 ~~Alki Area Parking Overlay, the Director may waive the off-street parking space requirement for~~  
11 ~~an accessory dwelling unit if:~~

12                   a.       — The topography or location of existing principal or accessory  
13 ~~structures on the lot makes provision of an off-street parking space physically infeasible; or~~

14                   b.       — The lot is located in a restricted parking zone (RPZ) and a current  
15 ~~parking study is submitted showing a utilization rate of less than 75 percent for on-street parking~~  
16 ~~within 400 feet of all property lines of the site.))~~

17                   B.       Attached accessory dwelling units. Attached accessory dwelling units are subject  
18 to the following additional conditions:

1                    1. The gross floor area of an attached accessory dwelling unit may not  
 2 exceed 1,000 square feet, excluding garage area, unless the portion of the structure in which the  
 3 attached accessory dwelling unit is located existed as of December 31, 2017.

4                    2. In an SF 5000, SF 7200, or SF 9600 zone, only one entrance to the  
 5 structure may be located on each street-facing facade of the structure, unless multiple entrances  
 6 on the street-facing facade existed on January 1, 1993, or unless the Director determines that  
 7 topography, screening, or another design solution is effective in de-emphasizing the presence of  
 8 an additional entrance.

9                    ~~((B)) C.~~            ~~((Accessory))~~ Detached accessory dwelling units. ~~((, detached, additional~~  
 10 ~~provisions. The Director may authorize a detached))~~ Detached accessory dwelling units ~~((;~~  
 11 ~~and that unit may be used as a residence, only under the conditions set forth in subsection~~  
 12 ~~23.44.041.A and))~~ subject to the following additional conditions:

13                    1. Detached accessory dwelling units are required to meet the additional  
 14 development standards set forth in Table ~~((B))~~ A for 23.44.041.

<b>Table <del>((B))</del> <u>A</u> for 23.44.041</b>	
<b>Development standards for detached accessory dwelling units<sup>1,2</sup></b>	
a. Minimum lot size	<del>((4,000))</del> <u>3,200</u> square feet
b. Minimum lot width	25 feet
c. Minimum lot depth	70 feet <sup>3</sup> <del>((2))</del>
d. Maximum lot coverage	<del>((The provisions of Section 23.44.010 apply.))</del> <u>Detached accessory dwelling units are subject to the requirements governing maximum lot coverage and lot coverage exceptions in subsections 23.44.010.C and 23.44.010.D.</u>
e. Maximum rear yard coverage	<del>((A detached))</del> <u>Detached accessory dwelling units, together with any other accessory structures and other portions of the principal structure, <del>((is limited to a maximum combined coverage of 40 percent of the rear yard))</del> are subject to the requirements governing maximum rear yard coverage exceptions in subsections 23.44.014.D.</u>

**Table ((B)) A for 23.44.041**  
**Development standards for detached accessory dwelling units<sup>1,2</sup>**

<p>f. Maximum ((<del>gross floor area</del>) <u>size</u>)</p>	<p>((800)) <u>The gross floor area of a detached accessory dwelling unit may not exceed 1,000 square feet ((including)) excluding garage and storage areas, ((but excluding covered)) porches and covered decks that are less than 25 square feet in area, and ((underground areas measured as set forth in Section 23.86.007)) gross floor that is underground. Up to 35 square feet of floor area dedicated to long-term bicycle parking shall be exempt from the gross floor area calculation for a detached accessory dwelling unit. The bicycle parking area shall be provided in a safe, and convenient location, emphasizing user convenience and theft deterrence, and shall be located where bicyclists are not required to carry bicycles on stairs to access the parking. Where practicable, long-term bicycle parking shall include a variety of rack types to accommodate different types of bicycles.</u></p>				
<p>g. Front yard</p>	<p>A detached accessory dwelling unit may not be located within the front yard required by subsection 23.44.014.B, except on a through lot pursuant to Section 23.40.030 or Section 23.40.035, ((and row i of this Table B for 23.44.041:))</p>				
<p>h. Minimum side yard</p>	<p>((The provisions of subsection 23.44.014.C apply.<sup>7</sup>)) <u>A detached accessory dwelling unit may not be located within the side yard required by subsection 23.44.014.B except as provided in subsection 23.44.014.C.3 or 23.44.014.C.4.<sup>4</sup></u></p>				
<p>i. Minimum rear yard</p>	<p>A detached accessory dwelling unit may be located within a required rear yard if it is not within 5 feet of any lot line, unless the lot line is adjacent to an alley, in which case a detached accessory dwelling unit may be located at that lot line.<sup>((3,)) 4, 5, 6</sup></p>				
<p>j. Location of entry</p>	<p>((Entrances to detached accessory dwelling units may not be located on facades)) <u>If the entrance to a detached accessory dwelling unit is located on a facade facing ((the nearest)) a side lot line or ((the)) a rear lot line, the entrance may not be within 10 feet of that lot line unless ((the nearest side)) that lot line ((or rear lot line)) abuts an alley or other public right-of-way.</u></p>				
<p>k. Maximum height limits<sup>7, 8, 9 ((6))</sup></p>	<p>Lot width (feet)</p>				
	<p>Less than 30</p>	<p>30 ((or greater)) up to ((35)) <u>40</u></p>	<p>((Above 35 up to 40))</p>	<p>((Above))40 up to 50((<sup>6</sup>))</p>	<p>50 or greater</p>
<p>(1) Base structure height limit (in feet)<sup>10</sup></p>	<p>((12)) <u>14</u></p>	<p>((14)) <u>16</u></p>	<p>((15))</p>	<p>((16))<u>18</u></p>	<p>((16)) <u>18</u></p>
<p>(2) Height allowed for pitched roof above base structure height limit (in feet)</p>	<p>3</p>	<p>7</p>	<p>((7))</p>	<p>((6))<u>5</u></p>	<p>7</p>

<b>Table ((B)) <u>A</u> for 23.44.041</b>					
<b>Development standards for detached accessory dwelling units<sup>1,2</sup></b>					
(3) Height allowed for shed or butterfly roof above base structure height limit (in feet); see Exhibit A for 23.44.041	3	4	((4))	4	4
1. Minimum separation from principal ((structure)) dwelling unit	5 feet				
((m. Number per lot	Only one detached accessory dwelling unit is allowed on a lot.))				



**Table ((B)) A for 23.44.041**  
**Development standards for detached accessory dwelling units<sup>1,2</sup>**

Footnotes to Table ((B)) A for 23.44.041

<sup>1</sup> The Director may allow an exception to standards a through f ((~~g~~)) and h ((~~i, and j~~)) through k pursuant to subsection ((~~23.44.041.B.3~~)) 23.44.041.C.2, for converting existing accessory structures to a detached accessory dwelling unit, including additions to an existing accessory structure.

<sup>2</sup> The Director may allow an exception to standards i and j if the exception allows for the preservation of an exceptional tree or a tree over 2 feet in diameter measured 4.5 feet above the ground.

~~((<sup>2</sup>)) <sup>3</sup> For lots that do not meet the lot depth requirement ((~~g~~)) but have a greater width than depth and an area greater than 5,000 square feet, a detached accessory dwelling unit is permitted, provided the detached accessory dwelling unit is not located in a required yard.~~

~~((<sup>3</sup> The exceptions from standard yard requirements in subsection 23.44.014.C.6.a shall also apply.))~~

<sup>4</sup> External architectural details with no living area, such as chimneys, eaves, cornices, and columns, may project no closer than 3 feet from any lot line. Bay windows are limited to 8 feet in width and may project no closer than 3 feet from any lot line. Other projections that include interior space, such as garden windows, must start a minimum of 30 inches above the finished floor, have a maximum dimension of 6 feet in height and 8 feet in width, and project no closer than 3 feet from any lot line.

~~((<sup>4</sup>)) <sup>5</sup> If the lot line is adjacent to an alley and a detached accessory dwelling unit includes a garage with a vehicle entrance that faces the alley, the garage portion of the structure may not be located within 12 feet of the centerline of the alley.~~

~~((<sup>5</sup>)) <sup>6</sup> On a reversed corner lot, no detached accessory dwelling unit shall be located in that portion of the required rear yard that abuts the required front yard of the adjoining key lot.~~

~~((<sup>6</sup>)) <sup>7</sup> Features such as chimneys, antennas, and flagpoles may extend up to 4 feet above the maximum allowed height.~~

~~((<sup>7</sup> Detached accessory dwelling units on lots that have a width greater than 40 feet up to 50 feet may be built to the maximum height limit applicable in the column for lots greater than 50 feet when the detached accessory dwelling unit is located on a lot with a rear lot line that is adjacent to an alley.))~~

<sup>8</sup> Projections that accommodate windows and result in additional interior space, including dormers, clerestories, and skylights, may extend no higher than the ridge of a pitched roof permitted pursuant to row k if all ((~~of~~)) conditions of subsection 23.44.012.C.3 are satisfied.

<sup>9</sup> Any structure with a green roof or other features necessary to meet a green building standard, as defined by the Director by rule, may extend up to 2 feet above the maximum allowed height.

<sup>10</sup> Open railings that accommodate roof decks may extend 4 feet above the base structure height limit.

1 **Exhibit A for 23.44.041**

2 **Additional roof pitch height and base height limit**

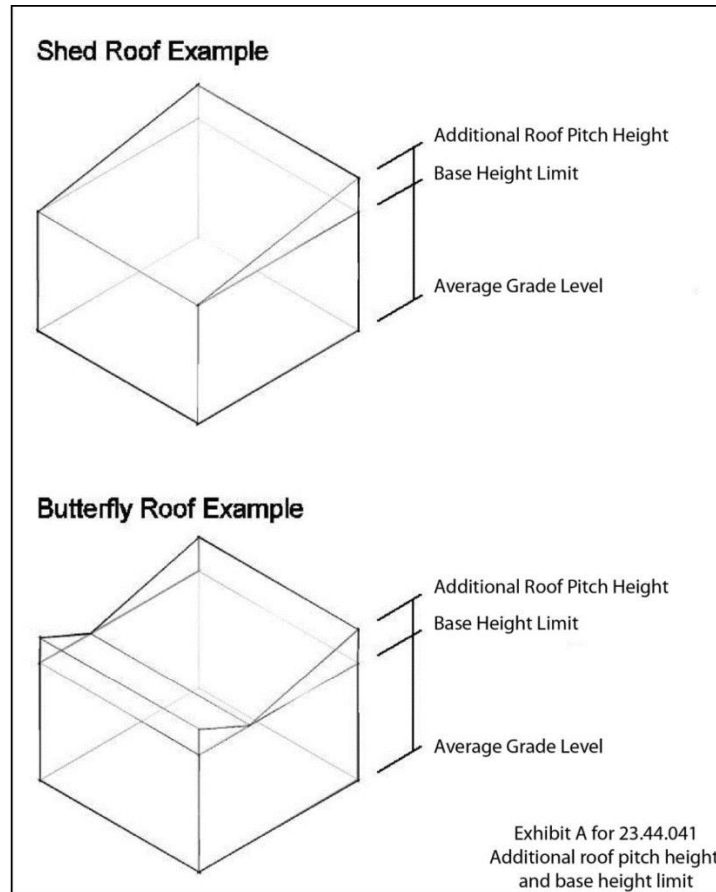

3

1                   2.       Conversion of accessory structures. An existing accessory structure that is  
2 not located in a required front yard, or that is located in a front yard where Section 23.40.030 or  
3 23.40.035 applies, may be converted into a detached accessory dwelling unit if the structure  
4 complies with the minimum standards set forth in Sections 22.206.010 through 22.206.140 of the  
5 Housing and Building Maintenance Code and with the Seattle Residential Code, if work  
6 requiring a permit is performed on the structure or has previously been performed without a  
7 permit. ~~((The))~~ To allow the conversion of an existing accessory structure, the Director may  
8 allow an exception to one or more of the development standards for accessory dwelling units  
9 contained in ~~((subsection 23.44.041.A.5 and))~~ standards a through f, and h ~~((, i and j))~~ through k,  
10 listed in Table ~~((B))~~ A for 23.44.041, provided the conversion does not increase the structure’s  
11 nonconformity with the standard. ~~((and))~~ An existing accessory structure may be converted if the  
12 applicant can demonstrate that the accessory structure ~~((was constructed))~~ existed prior to ~~((June~~  
13 ~~1, 1999))~~ December 31, 2017, as an accessory structure. If an accessory structure ~~((constructed))~~  
14 existing prior to ~~((June 1, 1999))~~ December 31, 2017, was replaced to the same configuration in  
15 accordance with the standards of Section 23.42.112, then the replacement structure also qualifies  
16 for conversion under this subsection 23.44.041.C.2. For purposes of this subsection  
17 23.44.041.C.2, the term “conversion” means either keeping the accessory structure intact or  
18 removing and rebuilding the accessory structure, provided that any expansion or relocation of the  
19 accessory structure complies with the development standards for detached accessory dwelling  
20 units.

21                   ~~((C. — Owner occupancy~~

22                   1. — Requirement. An owner with at least a 50 percent interest in the property  
23 ~~must occupy either the principal dwelling unit or the accessory dwelling unit for six or more~~

1 ~~months of each calendar year as the owner's permanent residence. The Director may waive this~~  
2 ~~requirement for up to three years if a letter is submitted that provides evidence to the Director~~  
3 ~~showing good cause why the requirement for owner occupancy should be waived. Good cause~~  
4 ~~may include job dislocation, sabbatical leave, education, or illness.~~

5           2. ~~Violation. If an owner is unable or unwilling to fulfill the requirements of~~  
6 ~~subsection 23.44.041.C.1, the owner shall remove those features of the accessory dwelling unit~~  
7 ~~that make it a dwelling unit. Failure to do so will constitute a violation of this Title 23 and the~~  
8 ~~owner will be subject to penalties pursuant to Sections 23.90.018, 23.90.019 and 23.90.020.~~

9           3. ~~Covenant recording. Prior to issuance of a permit establishing an~~  
10 ~~accessory dwelling unit, the owner(s) shall sign under oath and record in the King County~~  
11 ~~Recorder a covenant by the owner(s) to the City of Seattle stating that the owner(s) agree to~~  
12 ~~restrict use of the principal and accessory dwelling units in compliance with the requirements of~~  
13 ~~this subsection 23.44.041.C and notify all prospective purchasers of those requirements. Falsely~~  
14 ~~certifying to the terms of the covenant or failure to comply with the terms of the covenant is~~  
15 ~~subject to penalties pursuant to Sections 23.90.018, 23.90.019 and 23.90.020.~~

16           ~~The covenant shall run with the land and be binding upon the property owner,~~  
17 ~~his/her heirs and assigns, and upon any parties subsequently acquiring any right, title or interest~~  
18 ~~in the property. The covenant shall be in a form prescribed by the Director that includes the legal~~  
19 ~~description of the principal use lot. The property owner(s) shall return the original covenant with~~  
20 ~~recording stamp to the Department before the building permit for the accessory dwelling unit is~~  
21 ~~issued.~~

22           4. ~~Covenant release. At the request of a property owner and after an~~  
23 ~~inspection finding that an accessory dwelling unit has been removed from the owner's property,~~

1 ~~the Department shall record a release of any previously recorded covenant for that accessory~~  
2 ~~dwelling unit.))~~

3 D. Single-family status unaffected. A single-family lot with any number of accessory  
4 dwelling units shall be considered a single-family ((residence)) dwelling unit for purposes of  
5 rezone criteria (Section 23.34.011).

6 Section 6. Section 23.45.545 of the Seattle Municipal Code, last amended by Ordinance  
7 125791, is amended as follows:

8 **23.45.545 Standards for certain accessory uses**

9 \*\*\*

10 I. In LR zones, accessory dwelling units are allowed((;)) in single-family, rowhouse and  
11 townhouse units, as follows:

12 1. One accessory dwelling unit is allowed for each single-family, rowhouse, or  
13 townhouse unit that is a "principal unit."~~((;))~~ A "principal unit" is a dwelling unit that is not an  
14 accessory dwelling unit.

15 2. ~~((The owner of a principal unit shall comply with the owner occupancy~~  
16 ~~requirements of subsection 23.44.041.C.~~

17 ~~3.))~~2. The height limit for a detached accessory dwelling unit is 20 feet, except  
18 that the ridge of a pitched roof on a detached accessory dwelling unit may extend up to 3 feet  
19 above the 20-foot height limit. All parts of the roof above the height limit shall be pitched at a  
20 rate of not less than 4:12. No portion of a shed roof is permitted to extend beyond the 20-foot  
21 height limit.

22 ~~((4))~~3. The maximum gross floor area of an accessory dwelling unit is 650 square  
23 feet, provided that the total gross floor area of the accessory dwelling unit does not exceed 40

1 percent of the total gross floor area in residential use on the lot or unit lot, if present, exclusive of  
2 garages, storage sheds, and other non-habitable spaces.

3 ~~((5))~~4. An accessory dwelling unit shall be located completely within the same  
4 structure as the principal unit or in an accessory structure located between the single-family,  
5 rowhouse, or townhouse unit and the rear lot line.

6 ~~((6))~~5. The entrance to an accessory dwelling unit provided within the same  
7 structure as the principal unit shall be provided through one of the following configurations:

- 8 a. Through the primary entry to the principal unit; or
- 9 b. Through a secondary entry on a different facade than the primary entry  
10 to the principal unit; or
- 11 c. Through a secondary entry on the same facade as the primary entry to  
12 the principal unit that is smaller and less visually prominent than the entry to the principal unit,  
13 and does not have a prominent stoop, porch, portico or other entry feature.

14 ~~((7))~~6. Exterior stairs. Exterior stairs providing access to an accessory dwelling  
15 unit may not exceed 4 feet in height, except for exterior stairs providing access to an accessory  
16 dwelling unit located above a garage.

17 ~~((8))~~7. Parking. Parking is not required for an accessory dwelling unit.

18 ~~((9))~~8. In the Shoreline District, accessory dwelling units in single-family,  
19 rowhouse, and townhouse units shall be as provided in Chapter 23.60A, and where allowed in  
20 the Shoreline District, ~~((they))~~ are also subject to the provisions in this subsection 23.45.545.I.

21 J. Urban farms are subject to the standards in Section 23.42.051 and the conditional use  
22 requirement in subsection 23.45.504.C.8.

1 Section 7. Section 23.84A.002 of the Seattle Municipal Code, last amended by Ordinance  
2 125791, is amended as follows:

3 **23.84A.002 “A”**

4 \* \* \*

5 “Atrium, shopping.” See “Shopping atrium.”

6 “Attached accessory dwelling unit.” See “Residential use.”

7 “Automobile wrecking yard.” See “Solid waste management, Salvage yard,” under  
8 “Utility.”

9 \* \* \*

10 Section 8. Section 23.84A.032 of the Seattle Municipal Code, last amended by Ordinance  
11 125603, is amended as follows:

12 **23.84A.032 “R”**

13 \* \* \*

14 “Residential use” means any one or more of the following:

15 1. “Accessory dwelling unit” means one or more rooms that:

16 a. ~~((are))~~ Are located within ~~((an owner occupied))~~ a principal  
17 dwelling unit ~~((;))~~ or within an accessory structure on the same lot as ~~((an owner occupied))~~ a  
18 principal dwelling unit;

19 b. ~~((meet))~~ Meet the standards of Section 23.44.041, ~~((or))~~ Section  
20 23.45.545, or Chapter 23.47A, as applicable;

21 c. ~~((are))~~ Are designed, arranged, and intended to be occupied by not  
22 more than one household as living accommodations independent from any other household; and

23 d. ~~((are))~~ Are so occupied or vacant.

1                    2.        “Attached accessory dwelling unit” means an accessory dwelling unit that  
2 is within a principal dwelling unit.

3                    ~~((2))~~ 3.        “Adult family home” means an adult family home defined and  
4 licensed as such by ~~((The))~~ the State of Washington in a dwelling unit.

5                    ~~((3))~~ 4.        “Apartment” means a multifamily residential use that is not a  
6 cottage housing development, rowhouse development, or townhouse development.

7                    ~~((4))~~ 5.        “Artist’s studio/dwelling” means a combination working studio  
8 and dwelling unit for artists, consisting of a room or suite of rooms occupied by not more than  
9 one household.

10                   ~~((5))~~ 6.        “Assisted living facility” means a use licensed by ~~((The))~~ the State  
11 of Washington as a boarding home pursuant to RCW Chapter 18.20~~((;))~~ that contains at least two  
12 assisted living units for people who have either a need for assistance with activities of daily  
13 living (which are defined as eating, toileting, ambulation, transfer ~~((f))~~ (e.g., moving from bed to  
14 chair or chair to bath), ~~((;))~~ and bathing) or some form of cognitive impairment but who do not  
15 need the skilled critical care provided by nursing homes. See “Assisted living unit.”

16                   ~~((6))~~ 7.        “Carriage house” means a dwelling unit in a carriage house  
17 structure.

18                   ~~((7))~~ 8.        “Carriage house structure” means a structure within a cottage  
19 housing development, in which one or more dwelling units are located on the story above an  
20 enclosed parking garage at ground level that either abuts an alley and has vehicle access from  
21 that alley, or is located on a corner lot and has access to the parking in the structure from a  
22 driveway that abuts and runs parallel to the rear lot line of the lot. See also “Carriage house.”



Accessory Dwelling Units

Index # ~~File Name:~~ 1.0016 - Seattle ADU Legislation\_from Mayor Durkan.pdf

LEG Accessory Dwelling Units ORD  
D7

1                    ~~((8))~~ 9.            “Caretaker’s quarters” means a use accessory to a non-residential  
2 use consisting of a dwelling unit not exceeding 800 square feet of living area and occupied by a  
3 caretaker or watchperson.

4                    ~~((9))~~ 10.            “Congregate residence” means a use in which rooms or lodging,  
5 with or without meals, are provided for nine or more non-transient persons not constituting a  
6 single household, excluding single-family dwelling units for which special or reasonable  
7 accommodation has been granted.

8                    ~~((10))~~ 11.            “Cottage housing development” means a use consisting of cottages  
9 arranged on at least two sides of a common open space or a common amenity area. A cottage  
10 housing development may include a carriage house structure. See “Cottage,” “Carriage house,”  
11 and “Carriage house structure.”

12                    ~~((11))~~ 12.            “Detached accessory dwelling unit” means an accessory dwelling  
13 unit in an accessory structure.

14                    ~~((12))~~ 13.            “Domestic violence shelter” means a dwelling unit managed by a  
15 nonprofit organization, which unit provides housing at a confidential location and support  
16 services for victims of domestic violence.

17                    ~~((13))~~ 14.            “Floating home” means a dwelling unit constructed on a float that  
18 is moored, anchored, or otherwise secured in the water.

19                    ~~((14))~~ 15.            “Mobile home park” means a tract of land that is rented for the use  
20 of more than one mobile home occupied as a dwelling unit.

21                    ~~((15))~~ 16.            “Multifamily residential use” means a use consisting of two or  
22 more dwelling units in a structure or portion of a structure, excluding accessory dwelling units.

1                    ~~((16))~~ 17.        “Multifamily residential use, low-income disabled” means a  
2 multifamily residential use in which at least 90 percent of the dwelling units are occupied by one  
3 or more persons who have a handicap as defined in the Federal Fair Housing Amendments Act  
4 and who constitute a low-income household.

5                    ~~((17))~~ 18.        “Multifamily residential use, low-income elderly” means a  
6 residential use in which at least 90 percent of the dwelling units are occupied by one or more  
7 persons 62 or more years of age who constitute a low-income household.

8                    ~~((18))~~ 19.        “Multifamily residential use, low-income elderly/low-income  
9 disabled” means a multifamily residential use in which at least 90 percent of the dwelling units  
10 (not including vacant units) are occupied by a low-income household that includes a person who  
11 has a handicap as defined in the Federal Fair Housing Amendment Act or a person 62 years of  
12 age or older, as long as the housing qualifies for exemptions from prohibitions against  
13 discrimination against families with children and against age discrimination under all applicable  
14 fair housing laws and ordinances.

15                    ~~((19))~~ 20.        “Nursing home” means a use licensed by ~~((The))~~ the State of  
16 Washington as a nursing home, which provides full-time convalescent and/or chronic care for  
17 individuals who, by reason of chronic illness or infirmity, are unable to care for themselves, but  
18 that does not provide care for the acutely ill or surgical or obstetrical services. This definition  
19 excludes hospitals or sanitariums.

20                    ~~((20))~~ 21.        “Rowhouse development” means a multifamily residential use in  
21 which all principal dwelling units on the lot meet the following conditions:

22                    a.        ~~((each))~~ Each dwelling unit occupies the space from the ground to  
23 the roof of the structure in which it is located;

Accessory Dwelling Units

Index # 1 File Name: 1.0016 - Seattle ADU Legislation\_from Mayor Durkan.pdf

LEG Accessory Dwelling Units ORD  
D7

- 1                                    b.        ~~((no))~~ No portion of a dwelling unit, except for an accessory
- 2 dwelling unit or shared parking garage, occupies space above or below another dwelling unit;
- 3                                    c.        ~~((each))~~ Each dwelling unit is attached along at least one common
- 4 wall to at least one other dwelling unit, with habitable interior space on both sides of the
- 5 common wall, or abuts another dwelling unit on a common lot line;
- 6                                    d.        ~~((the))~~ The front of each dwelling unit faces a street lot line;
- 7                                    e.        ~~((each))~~ Each dwelling unit provides pedestrian access directly to
- 8 the street that it faces; and
- 9                                    f.        ~~((no))~~ No portion of any other dwelling unit, except for an attached
- 10 accessory dwelling unit, is located between any dwelling unit and the street faced by the front of
- 11 that unit.

12                                    ~~((21))~~ 22.        “Single-family dwelling unit” means a detached principal structure

13 having a permanent foundation, containing one dwelling unit, except that the structure may also

14 contain ~~((an))~~ one or two attached accessory dwelling units where expressly authorized pursuant

15 to this Title 23. A detached accessory dwelling unit is not considered a single-family dwelling

16 unit for purposes of this Chapter 23.84A.

17                                    ~~((22))~~ 23.        “Townhouse development” means a multifamily residential use

18 that is not a rowhouse development, and in which:

- 19                                    a.        ~~((each))~~ Each dwelling unit occupies space from the ground to the
- 20 roof of the structure in which it is located;
- 21                                    b.        ~~((no))~~ No portion of a dwelling unit occupies space above or below
- 22 another dwelling unit, except for an attached accessory dwelling unit and except for dwelling
- 23 units constructed over a shared parking garage; and

1 c. ~~((each))~~ Each dwelling unit is attached along at least one common  
2 wall to at least one other dwelling unit, with habitable interior space on both sides of the  
3 common wall, or abuts another dwelling unit on a common lot line.

4 \* \* \*

5 Section 9. Section 23.84A.038 of the Seattle Municipal Code, last amended by Ordinance  
6 125792, is amended as follows:

7 **23.84A.038 “T”**

8 \* \* \*

9 “Tree, exceptional” means a tree designated as such per Chapter 25.11.

10 “Triplex” means a single structure containing three ~~((3))~~ dwelling units, none of which  
11 is an accessory dwelling unit authorized under Section 23.44.041.

12 Section 10. Section 23.86.007 of the Seattle Municipal Code, last amended by Ordinance  
13 125791, is amended as follows:

14 **23.86.007 Floor area and floor area ratio measurement**

15 \* \* \*

16 D. Pursuant to subsections 23.44.011.C, 23.44.018.A, 23.45.510.D, and  
17 23.47A.013.B, and Section 23.48.020, for certain structures in ~~((RSL))~~ single-family,  
18 multifamily, commercial, and Seattle Mixed zones, portions of a story that extend no more than 4  
19 feet above existing or finished grade, whichever is lower, are exempt from calculation of gross  
20 floor area. The exempt gross floor area of such partially below-grade stories is measured as  
21 follows:

- 1                    1.        Determine the elevation 4 feet below the ceiling of the partially below-
- 2                    grade story, or 4 feet below the roof surface if there is no next floor above the partially below-
- 3                    grade story;
- 4                    2.        Determine the points along the exterior wall of the story where the
- 5                    elevation determined in subsection 23.86.007.D.1 (~~above~~) intersects the abutting corresponding
- 6                    existing or finished grade elevation, whichever is lower;
- 7                    3.        Draw a straight line across the story connecting the two points on the
- 8                    exterior walls; and
- 9                    4.        The gross floor area of the partially below-grade story or portion of a
- 10                    partially below-grade story is the area of the story that is at or below the straight line drawn in
- 11                    subsection 23.86.007.D.3, excluding openings required by the Building Code for egress. (See
- 12                    Exhibit B for 23.86.007.)

\* \* \*

14                    Section 11. The Seattle Department of Construction and Inspections (SDCI) shall report

15                    annually for five years after implementation to the Planning, Land Use and Zoning Committee,

16                    or its successor committee, on citywide accessory dwelling unit permit activity. The report shall

17                    be delivered to the City Council by no later than June 30 of the following calendar year, with the

18                    first report due on June 30, 2021, and the final report due on June 30, 2025. This annual report

19                    shall include detailed information on all attached and detached accessory dwelling unit (ADU)

20                    permits issued and all permits finalized, including:

- 21                    A.        The number of permits issued to construct ADUs and the number of permits
- 22                    finalized over the previous five-year period. This should include the number of permits issued and

1 finished for a second ADU and details on whether the second ADU was constructed in a new  
2 structure or through conversion of or an addition to an existing structure;

3 B. The number of permits issued for ADUs that were associated with the  
4 redevelopment of a single-family lot that included demolition of a principal single-family  
5 dwelling unit;

6 C. A map that shows the location and dispersion of both attached and detached  
7 accessory dwelling units, including the number and location of lots that have two ADUs;

8 D. For each detached accessory dwelling unit permit issued, the report shall state the  
9 height, gross floor area, total square footage of the lot where the detached accessory dwelling  
10 unit is located, and total lot coverage of all structures on the lot;

11 E. Information on the number of short-term rental operator licenses issued by the  
12 Department of Finance and Administrative Services (FAS) that authorizes short-term rental use  
13 in an ADU. In addition, the City Council requests that SDCI work with FAS to develop this  
14 information and identify recommendations, as appropriate, for modifications to the regulations  
15 governing short-term rental use. If the report reveals that a significant number of accessory  
16 dwelling units are being used solely as short-term rentals, the City Council intends to impose  
17 additional restrictions or a prohibition on short-term rental use in accessory dwelling units; and

18 F. The number of ADU permits that have included the addition of new off-street  
19 parking spaces. In addition, SDCI shall report on parking-related impacts, if any, that have been  
20 identified by the City as a result of new ADUs in an area. This should include a recommendation  
21 on any modifications the City Council should consider to the off-street parking requirements for  
22 accessory dwelling units, including geographic specific recommendations.

1           G.     By July 1, 2022, SDCI and the Office of Planning and Community Development  
2 (OPCD) shall conduct a voluntary survey of ADU owners and occupants to collect descriptive  
3 statistics of owners and occupants of ADUs. This shall include information on the use, size,  
4 financing, rent charged, ownership, design, and construction of ADUs built in Seattle, and  
5 general demographic information of ADU owners and occupants. Any information collected  
6 must be in compliance with applicable legal limitations. OPCD and SDCI shall provide a report  
7 to the Planning, Land Use and Zoning Committee, or its successor committee, on the survey  
8 results. In addition, OPCD and SDCI shall report on challenges to constructing ADUs identified  
9 through the survey results and recommend changes to address identified challenges.

10           Section 12. The City Council requests that the Seattle Department of Construction and  
11 Inspections develop a process to ensure that, at the time a permit to construct an accessory  
12 dwelling unit is issued, property owners are provided educational materials about becoming a  
13 landlord, including applicable state and local laws about landlord obligations and the rights of  
14 renters. In addition, SDCI shall notify those property owners of any available trainings for  
15 landlords.

16           Section 13. The City Council requests that the Seattle Department of Construction and  
17 Inspections (SDCI) develop an amnesty program for accessory dwelling units that were  
18 constructed without permits. The program shall permit owners of accessory dwelling units  
19 constructed without a permit to come forward during a certain time period and legalize their  
20 units without penalty. SDCI shall develop standards that will not discourage owners from  
21 seeking legalization of the units voluntarily, including identifying the potential for flexibility  
22 from Land Use Code and Building Code standards that would simplify and reduce the cost of  
23 legalizing these units while ensuring that the accessory dwelling units are safe and habitable.

1           Section 14. The City Council requests that the Office of Housing (OH) reports to the  
2 Council by September 1, 2020, on the outcomes and lessons learned from the pilot program that  
3 authorizes loans to low-income homeowners who want to create additional habitable space or an  
4 accessory dwelling unit on their property. In addition, OH shall provide recommendations on the  
5 potential for expanding this program, or creating a new program, to offer financial support to any  
6 homeowner who enters into an agreement to offer the ADU as a rent- and income-restricted unit.

7           Section 15. The Council requests that the Seattle Department of transportation consider  
8 opportunities to increase access to public bicycle parking areas in single-family zones.

9           Section 16. Section 1 of this ordinance shall take effect and be in force on March 1, 2020.



Accessory Dwelling Units

Index # ~~File Name~~: 1.0016 - Seattle ADU Legislation\_from Mayor Durkan.pdf

LEG Accessory Dwelling Units ORD  
D7

1 Section 17. This ordinance shall take effect and be in force 30 days after its approval by  
2 the Mayor, but if not approved and returned by the Mayor within ten days after presentation, it  
3 shall take effect as provided by Seattle Municipal Code Section 1.04.020.

4 Passed by the City Council the \_\_\_\_\_ day of \_\_\_\_\_, 2019,  
5 and signed by me in open session in authentication of its passage this \_\_\_\_\_ day of  
6 \_\_\_\_\_, 2019.

7 \_\_\_\_\_  
8 President \_\_\_\_\_ of the City Council

9 Approved by me this \_\_\_\_\_ day of \_\_\_\_\_, 2019.

10 \_\_\_\_\_  
11 Jenny A. Durkan, Mayor

12 Filed by me this \_\_\_\_\_ day of \_\_\_\_\_, 2019.

13 \_\_\_\_\_  
14 Monica Martinez Simmons, City Clerk

15 (Seal)

**Ordinance No. 12- 2007**

**Ordinance to Amend Ordinance 7-2006 Regarding Detached Accessory Dwelling Units on Rural Parcels Smaller than Five Acres in Size to Comply with Orders of the Growth Management Hearings Board**

WHEREAS, on June 8, 2006, Ordinance 7-2006 was adopted to amend San Juan County Code sections pertaining to accessory dwelling units (ADUs) with the purpose of bringing San Juan County into compliance with an order of the Western Washington Growth Management Hearings Board (Growth Board); and

WHEREAS, on February 12, 2007, the Growth Board ruled in its Compliance Order and Final Decision and Order that “The only provision of the amendments that the Board has found noncompliant is SJCC 18.40.240(G)(4)”; and

WHEREAS, the Growth Board’s February 12, 2007 Compliance Order and Final Decision and Order states that:

The regulations that permit a detached ADU to be constructed or converted in a nonconforming rural lot of less than 5 acres (SJCC 18.40.240(G)(4)) fail to comply with RCW 36.70A.070(5) by expanding the structural intensity in rural zones beyond that which is set out in the County comprehensive plan and/or is inconsistent with the GMA....SJCC 18.40.240(G)(4) also creates urban growth in rural zones and promotes sprawl, thus not complying with RCW 36.70A.110(1) and RCW 36.70A.020(2)

; and

WHEREAS, the County Council desires to take a narrow approach to the Growth Board’s Order and bring SJCC 18.40.240(G)(4) into compliance with the Growth Management Act; and

WHEREAS, on May 18, 2007, the Planning Commission held a public hearing on the proposed ordinance; and

WHEREAS, on May 30, 2007, notice of a Council public hearing was published in the official newspapers; and

WHEREAS, on June 19, 2007, the Council held a public hearing on this matter.

NOW, THEREFORE, IT IS ORDAINED AS FOLLOWS:

Section 1. San Juan County Code §18.40.240 and Ordinance 7-2006 are hereby amended to read as follows:

**18.40.240 Accessory dwelling units (ADUs).**

The following standards apply to all accessory dwelling units:

A. Accessory Dwelling Unit. Where not otherwise prohibited by this code, only one attached or detached accessory dwelling unit is permitted on any lot for which this code allows a

principal residence as the principal use of the lot; provided, that all of the requirements of this section are met, except where the applicable density for that lot allows for additional residences. Each detached accessory dwelling unit shall be counted as a separate dwelling unit for density calculations, except when allowed pursuant to an ADU permit.

- B. A detached ADU is permitted in the Eastsound urban growth area, the Lopez Village urban growth area and in all activity center land use districts, except island center district, on any lot that allows a principal residence as the principal use of the lot. Each ADU in these areas shall not be counted in density calculations.
- C. Subject to the provisions of this section, a detached ADU is permitted in the following land use districts: RFF, RR, RGU, AG, and FOR.
- D. An accessory dwelling unit is prohibited in the rural industrial, rural commercial, natural, and conservancy land use districts.
- E. An accessory dwelling unit is prohibited on parcels in the island centers district per SJCC 18.30.030 Table 3.1, footnote 13.
- F. The following standards apply to all accessory dwelling units:
  - 1. Size. An accessory dwelling unit permitted subsequent to the adoption of this section shall not exceed 1,000 square feet in living area as defined in SJCC 18.20.120.
  - 2. Parking. At least one additional off-street parking space shall be provided for the accessory dwelling unit in addition to the parking required for the principal residence.
  - 3. Driveway and Utilities. An accessory dwelling unit shall use the same driveway, septage/sewer system, and water system as the principal residence.
  - 4. Ownership. An accessory dwelling unit must be owned by the owner of the principal residence.
  - 5. Permits. Every new accessory dwelling unit will require a building permit. Every conversion of an existing structure to an accessory dwelling unit must meet all the requirements of this section and will require a building permit. Any additions to an existing building shall not exceed the allowable lot coverage or encroach onto setbacks. The size and design of the ADU shall conform to applicable standards in the building, plumbing, electrical, mechanical, fire, health and any other applicable codes.
- G. The following standards apply to all detached accessory dwelling units:
  - 1. ADU Permit. Every new detached accessory dwelling unit and every conversion of an existing structure to a detached accessory dwelling unit that does not meet the density requirement of the parcel on which it will be located shall require an "ADU permit." No more than one ADU permit shall be issued to a property owner in any calendar year. The fee for an ADU permit shall be the same as that for stormwater review. Prior to issuing any ADU permit, the applicant must submit for approval a site plan showing that the accessory dwelling unit and principal residence will meet the requirements of this section.
    - a. Within land use districts located inside of the boundaries of activity centers and urban growth areas, there is no restriction on the number of permits for detached accessory dwelling units.
    - b. Outside of the boundaries of activity centers and urban growth areas, the number of detached ADU permits in any calendar year shall not exceed 12 percent of the total

- number of building permits for new principal residences issued for the previous calendar year outside the boundaries of activity centers and urban growth areas. Two of that 12 percent (10 percent new, two percent conversions) of the permits released in any one year shall be restricted for the conversion of existing accessory structures that have legally existed for no less than five years. ADU permits shall be issued on a first come/first served basis under procedures established by the administrator. No unassigned ADU permits shall carry forward to the next year.
2. Distance. The maximum distance between the closest vertical walls of the main house and any detached accessory dwelling unit shall be no more than 100 feet. If the 100 foot dimension would result in a greater impact, the administrator may allow up to 150 feet separation.
  3. Location. Locate every new detached ADU and its utilities and driveway to avoid or minimize intrusion on the most sensitive open-space features of the site, including but not limited to:
    - a. Existing orchards, meadows and pasture areas;
    - b. Ridgelines and contrasting edges between landscape types unbroken by structures;
    - c. Rolling, open or steep open slopes; and
    - d. Critical areas.
  4. Parcel Size.
    - a. There is no minimum parcel size for a detached ADU in urban growth areas and activity centers. A detached ADU is not permitted on parcels less than one acre in size except in urban growth areas and activity centers.
    - b. A detached ADU is not permitted on parcels less than: (1) five acres in size in any rural district, (2) ten acres in size in the agricultural district, and (3) twenty acres in size in the forest district. A detached ADU on parcels larger than one acre and smaller than five acres, except in urban growth areas and activity centers, is permitted with the following restrictions:
      - i. One garage building and/or one accessory dwelling unit, each of which covers no more than 1,000 square feet of land area and each of which is no taller than 24 feet above existing grade as measured along a plumb line at any point.
      - ii. A combination of these uses in a single story structure no larger than 2,000 feet of land area and no taller than 16 feet above existing grade as measured along a plumb line at any point where either the garage building and/or accessory building unit do not exceed 1,000 square feet.
      - iii. A combination of these uses in a two-story structure no larger than 2,000 feet of total gross floor area, and no taller than 24 feet above existing grade as measured along a plumb line at any point where either the garage building and/or accessory building unit do not exceed 1,000 square feet.
    - c. The minimum parcel size for the construction of a detached accessory dwelling unit is five acres for any parcel with waterfront, 10 acres for parcels located in the agricultural district, 20 acres for parcels located in the forest district, and one acre for all parcels located in a rural land use district. This restriction does not apply to parcels located in urban growth areas or activity centers.

5. **Sequence of Construction.** Either the accessory dwelling unit or the principal residence may be built first. Regardless of the sequence of construction, every detached accessory dwelling unit must comply with the requirements of this section. When the principal residence is constructed after the ADU, the applicant must show that the structure indicated as the accessory dwelling unit was constructed according to all applicable requirements in effect at the time the building permit was issued for the accessory dwelling and the accessory dwelling unit does not exceed 1,000 square feet of living area.

**Section 2. Savings Clause.**

This ordinance shall not affect any pending suit or proceeding; or any rights acquired; or liability or obligation incurred under the sections amended or repealed; nor shall it affect any proceeding instituted under those sections. All rights and obligations existing prior to adoption of this ordinance shall continue in full force and effect.

**Section 3. Severability.**

If any provision of this ordinance or its application to any person is held invalid, the remainder of this ordinance and the application to other persons or circumstances shall not be affected. Remaining sections of the ordinance shall be interpreted to give effect to the spirit of the ordinance prior to removal of the portions declared invalid.

**Section 4. Effective Date.**

This ordinance shall take effect and be in full force and effect ten days after adoption by the County Council.

ADOPTED this 19th day of June 2007.

**COUNTY COUNCIL**

**SAN JUAN COUNTY, WASHINGTON**

ATTEST: Acting Clerk of the Council

By:                     Signed                      
                    Lisa Brown - Acting Clerk  
                                                            Date: 06/19/07

                                                            Signed                                                              
Bob Myhr, Chair  
District 6, Lopez/Shaw

                                                            Signed                                                              
Howard Rosenfeld, Vice-Chair  
District 3, Friday Harbor

REVIEWED BY COUNTY  
ADMINISTRATOR

                                                            ABSENT                                                              
Kevin M. M. Ranker, Member  
District 1, San Juan South

                                                            Signed                                                              
Pete Rose                                      Date: 06/12/07

APPROVED AS TO FORM ONLY  
RANDALL K. GAYLORD

                                                            Signed                                                              
Rich Peterson, Member  
District 2, San Juan North

By:                     Signed                      
                    Jonathan W. Cain   Date: 06/12/07

                                                            Signed                                                              
Alan Lichter, Member  
District 4, Orcas West

                                                            Signed                                                              
Gene Knapp, Member  
District 5, Orcas East

**14.16.710 Accessory dwelling units.**

(1) Requirements for Accessory Dwelling Units. One accessory dwelling unit is permitted as accessory to an existing single-family dwelling; provided, that the following requirements are met, except as may be further restricted by the connection limitation in SCC 14.16.920, Similk Beach LAMIRD:

(a) Owner Occupancy. Either the principal unit of the single-family dwelling or the accessory dwelling unit must be occupied by an owner of the property or an immediate family member of the property owner.

(b) No more than 1 family shall be allowed to occupy an accessory dwelling unit.

(c) Subdivision. Accessory dwelling units shall not be subdivided or otherwise segregated in ownership from the principal unit of the single-family dwelling, unless allowed by the zoning.

(d) Size and Scale. The square footage of the accessory dwelling unit shall be the minimum allowed by the building code and a maximum of 900 square feet excluding any garage area; provided, however, the square footage of the accessory dwelling unit shall not exceed 50% of the total square footage of the principal unit of the single-family dwelling excluding the garage area as it exists or as it may be modified.

(e) Location. The accessory dwelling unit may be attached to, included within the principal unit of the single-family dwelling, or located in a detached structure. All requirements of the International Building Codes regarding fire separation shall be met.

(i) No recreational vehicle, including park model trailers, shall be allowed as an accessory dwelling unit.

(ii) Any accessory dwelling unit included within a primary residence shall have no interconnected interior spaces.

(iii) All accessory dwelling units shall contain provisions for eating, sleeping, cooking and sanitation.

(f) Entrances. The principal unit of the single-family dwelling containing the accessory dwelling unit shall have only 1 obvious entrance visible to the street except where more than 1 entrance existed on or before adoption of the ordinance codified in this Section.

(g) Additions. Additions to an existing structure or newly constructed detached structures created for developing an accessory dwelling unit shall be designed consistent with the existing roof pitch, siding and windows of the principal dwelling unit.

(h) Parking. Three off-street parking spaces shall be provided for the combination of the main and

accessory dwelling units.

(i) Application. The property owner shall apply for an accessory dwelling permit with Skagit County Planning and Development Services.

(j) Recording Requirements. Approval of the accessory dwelling unit shall be subject to the applicant recording a document with the Skagit County Auditor prior to approval which runs with the land and identifies the address of the property, states that the owner(s) or an immediate family member must reside in either the principal dwelling unit or the accessory dwelling unit at least six months per year, includes a statement that the owner(s) will notify any prospective purchasers of the limitations of this Chapter, and provides for the removal of the accessory dwelling unit by the current owner if any of the requirements of this Chapter are violated.

(k) Elimination/Expiration. Elimination of an accessory dwelling unit may be accomplished by the following:

(i) The owner shall obtain either a demolition permit or a change of use permit.

(ii) The owner shall record a certificate with the Skagit County Auditor's Office stating that the accessory dwelling unit no longer exists on the property and that a final inspection has been performed by Skagit County Planning and Development Services. (Ord. O20170006 § 1 (Att. 1); Ord. O20070009 (part); Ord. R20020194 § 7; Ord. 17938 Attch. F (part), 2000)





## Zoning Code 2018 Update

You may have heard that there is a new zoning code for the City of Walla Walla. You heard right! City Development Services staff formulated a new Comprehensive Plan that was adopted in June 2018 by City Council.

Our new zoning code which implements the goals and policies of the Comprehensive Plan was adopted by City Council on December 19, 2018, with an effective date of January 2, 2019.

This document is intended to be a high-level guide to the changes that are outlined fully in Ordinance 2018-53. Please consult City staff or the ordinance for additional detail.

### The Changes

- Neighborhood Residential (RN) zone replaces former R-60, R-72, and R-96 zones
  - RN does not have a minimum lot size or lot dimensions
  - RN setbacks are 20 feet from front and rear property lines, 5 feet from either side (these are the same as former R-60 and R-72)
  - RN maximum lot coverage (how much of the lot can be covered with roofed structures, including home, garage, covered porches, sheds, etc) is 50%
  - RN maximum height is 35 feet (no change)
  - RN established a minimum density of 4 units per net acre (minus any critical areas and buffers and right of way to be dedicated)
  - RN allows for the development of: single-family homes, duplexes, triplexes, fourplexes, townhomes, and cottage housing
    - Cottage housing means multiple detached dwelling units that share common areas
    - Cottage homes may not be larger than 1000 square feet
- Accessory Dwelling Unit (ADU) standards were relaxed
  - Maximum size of 800 square feet (no longer dependent on home size)
  - Removed owner occupancy requirement
  - Removed neighbor comment requirement for detached ADUs
  - ADUs are allowed only for single-family homes
- Multifamily Residential (RM) development potential was increased
  - Established density requirements with a minimum of 20 units per acre and maximum of 75 units per acre
  - Lot coverage for RM increased to 65%
  - Building height for RM increased to 60 feet
- Standalone multifamily development in Highway Commercial (CH) zone was made easier
  - Level II review (administrative) instead of Level III (public hearing)
- Parking code requirements were reduced
  - Bicycle parking requirement increased to ten percent of parking stalls
  - Reductions of the number of required stalls made easier to grant
  - Parking table stall requirements decreased for specific commercial uses



- Residential parking requirements based on specific use (all standards are per unit):
  - 2 stalls for single family residential
  - 2 stalls for duplex
  - 1.5 stalls for multifamily
  - 1 stall for studio apartment
  - 1 stall for ADU
  - 1 stall for cottage home
- Added connectivity requirement for new residential developments
  - Minimum block length is 200 feet, maximum length is 600 feet
  - Maximum block perimeter is 1,400 feet
- Restrictions on use of new cul-de-sacs except when environmental or topographical constraints, existing development patterns, etc preclude street extension
  - When cul-de-sacs are allowed, an access way at the end of the cul-de-sac to provide pedestrian and cyclist access to adjacent developable land is required
  - Maximum length for cul-de-sacs increased to 600 feet
- Private lanes are not allowed for developments of more than 9 lots, may not connect 2 public streets, and may only provide access to 9 units of housing or less
  - Private lanes may be up to 600 feet long
  - Private lanes which access 5 or more units shall provide sidewalks on one side
- Updated the Urban Planned Community zone – mixed use zone (new definitions and requirements rather than using the County’s standards)
- Landscaping requirements clarified
  - Street frontage landscaping required for redevelopments
- Fences on corner lots no longer require a setback on the secondary front yard side
- Adaptive Reuse of Nonresidential Buildings in Residential Zones
  - Limited to major and minor arterials and collector streets
  - Only for existing buildings, not new construction
  - Level II use – no hearing
  - Limited kinds of uses
    - Medical/dental offices
    - Convenience stores
    - Professional offices
    - Retail bakeries/coffee shops
    - Florists
    - Seamstress/tailor/similar

## FAQs!

**Q:** Can I build a duplex? Is this lot big enough or zoned right for a duplex?

**A:** Yes! Duplexes are allowed in all residential zones. Be sure to meet setback, lot coverage, height, and parking requirements.

**Q:** Can I have a tiny home?

**A:** If it is site-built, yes. We do not currently allow for tiny homes built on wheels as they do not meet Washington State Building Codes.

**Q:** How many units can we put on this lot? How many lots can we split this lot into? What can I do with this lot?

**A:** It depends! The flexibility of the new zoning code means that it will depend on what will be a good fit for the neighborhood. Minimum density, setbacks, lot coverage, height and parking requirements must be met.

**RCW 43.63A.215****Accessory apartments—Development and placement—Local governments.**

(1) The department shall, in consultation with the affordable housing advisory board created in RCW **43.185B.020**, report to the legislature on the development and placement of accessory apartments. The department shall produce a written report by December 15, 1993, which:

(a) Identifies local governments that allow the siting of accessory apartments in areas zoned for single-family residential use; and

(b) Makes recommendations to the legislature designed to encourage the development and placement of accessory apartments in areas zoned for single-family residential use.

(2) The recommendations made under subsection (1) of this section shall not take effect before ninety days following adjournment of the 1994 regular legislative session.

(3) Unless provided otherwise by the legislature, by December 31, 1994, local governments shall incorporate in their development regulations, zoning regulations, or official controls the recommendations contained in subsection (1) of this section. The accessory apartment provisions shall be part of the local government's development regulation, zoning regulation, or official control. To allow local flexibility, the recommendations shall be subject to such regulations, conditions, procedures, and limitations as determined by the local legislative authority.

(4) As used in this section, "local government" means:

(a) A city or code city with a population that exceeds twenty thousand;

(b) A county that is required to or has elected to plan under the state growth management act; and

(c) A county with a population that exceeds one hundred twenty-five thousand.

[ **1993 c 478 § 7.**]

## Accessory Apartments Permitted Attached vs Detached 1994 through 2019

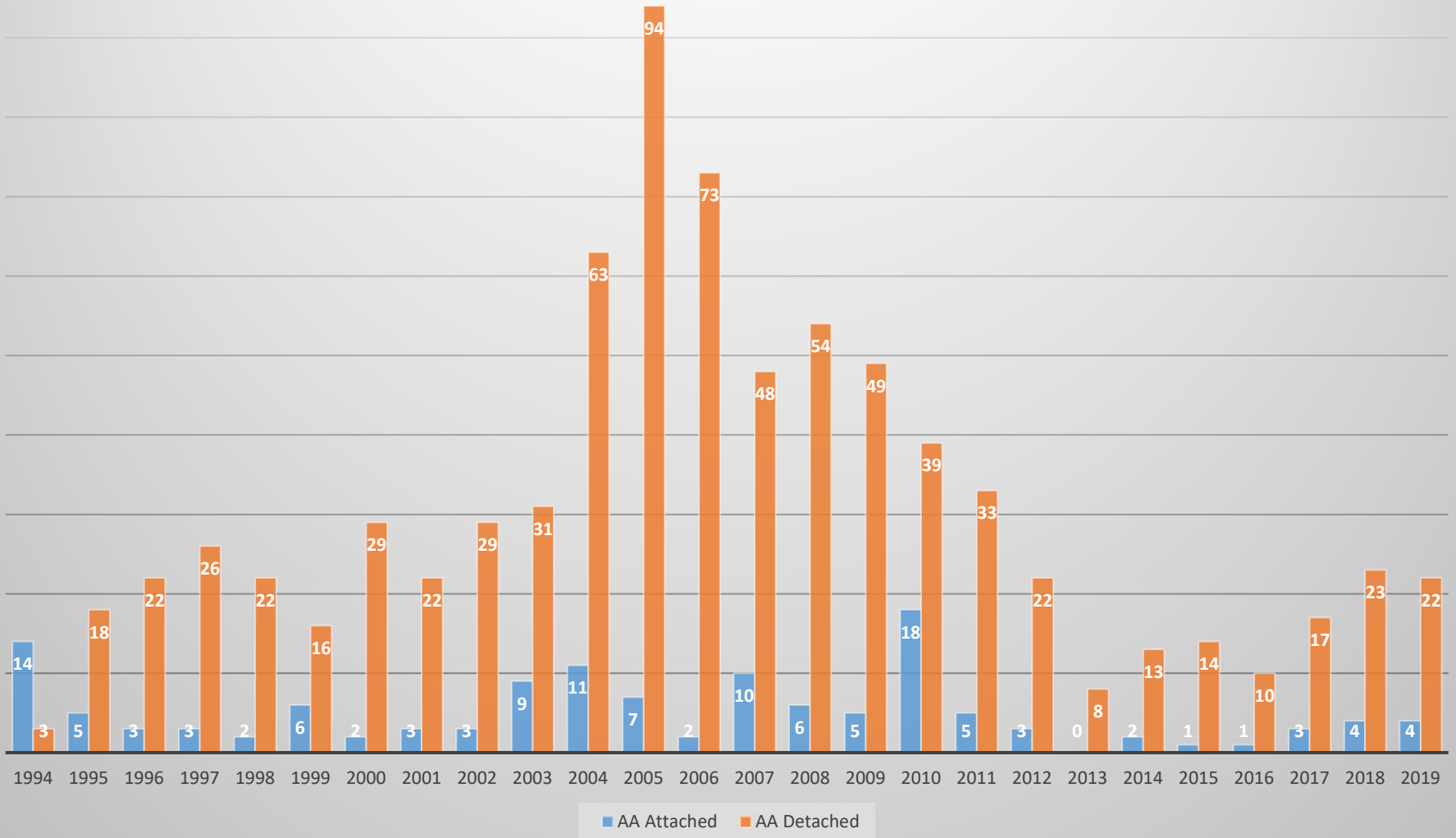

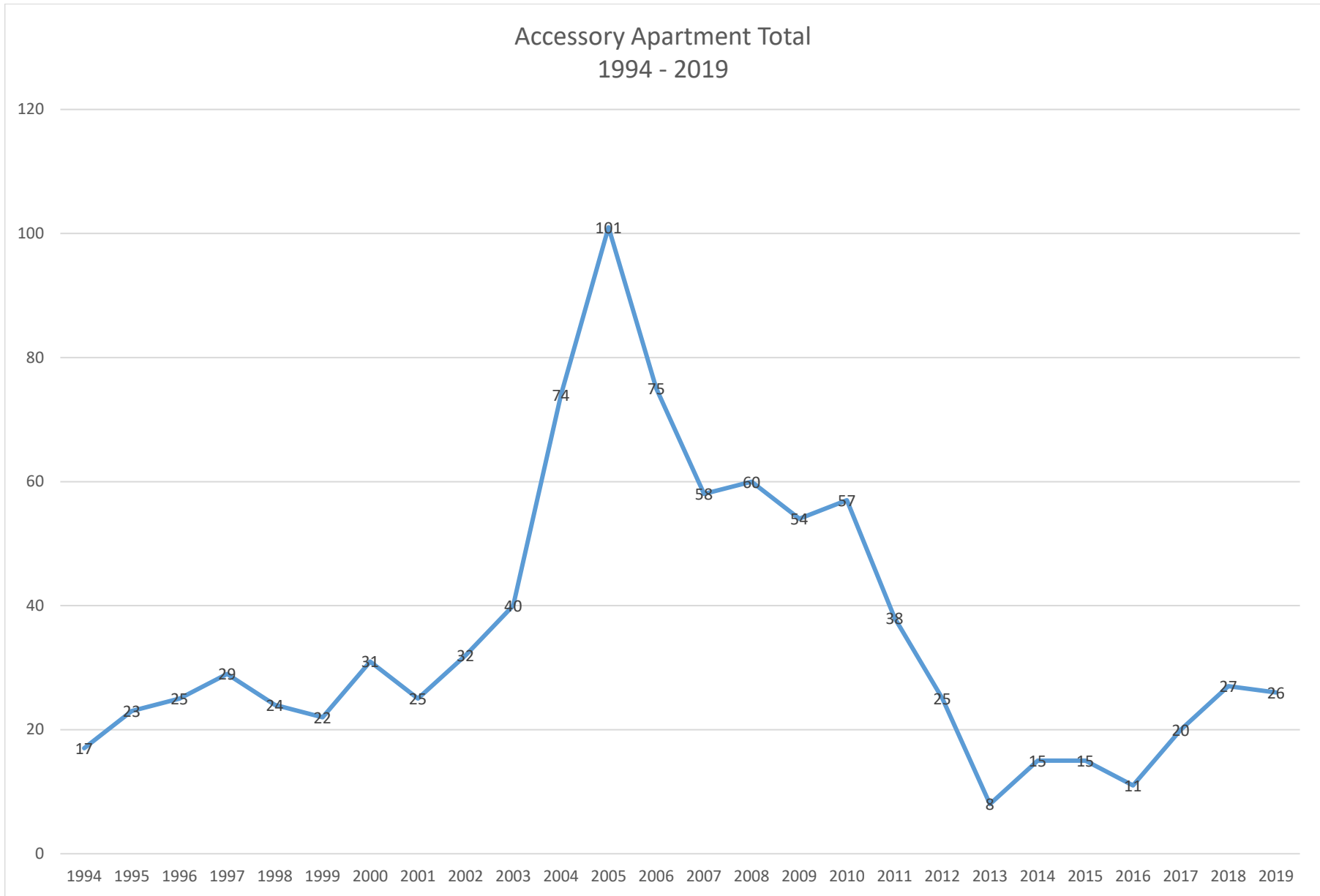

# NUMBER OF PERMITTED ACCESSORY APARTMENTS ATTACHED VS DETACHED UGA VS RURAL 1994 THROUGH 2019

AA Attached AA Detached

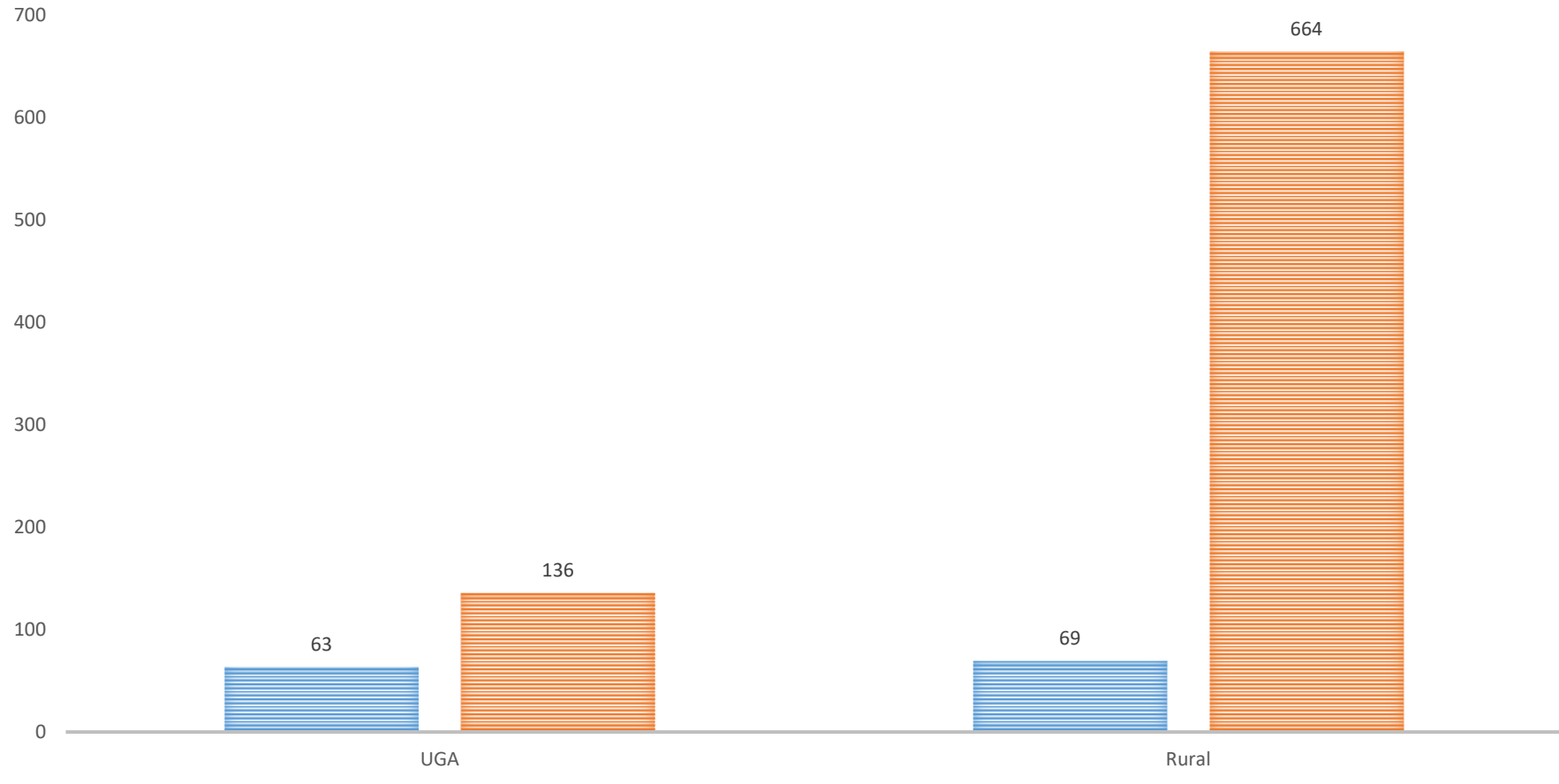

# Accessory Dwelling Units

Index # - File Name: 1.0021 - Accessory Apartment Data\_Snohomish County.pdf

AA Attached	R-5	R-9600	R-7200	R-8400	WFB	F	A-10	RC					
132	60	28	10	7	3	2	2	1					
AA Detached	R-5	R-9600	R-7200	R-8400	WFB	F	A-10	RC	MR	RD	A-10 : R-5	PRD SA-1 : R-5	F and R
800	580	32	13	23	11	20	16	9	7	6	4	3	2

AA Attached	R-5	R-9600	R-7200	R-8400	WFB	F	A-10	RC	MR	RD	A-10 : R-5	PRD SA-1 : R-5	F and R
60	28	10	7	3	2	2	1	0	0	0	0	0	0
AA Detached	R-5	R-9600	R-7200	R-8400	WFB	F	A-10	RC	MR	RD	A-10 : R-5	PRD SA-1 : R-5	F and R
580	32	13	23	11	20	16	9	7	6	4	3	2	2

Accessory Apartments	R-5	R-9600	R-7200	R-8400	WFB	F	A-10	RC	MR	RD	A-10 : R-5	PRD SA-1 : R-5	F and R
640	60	23	30	14	22	18	10	7	6	4	3	2	2

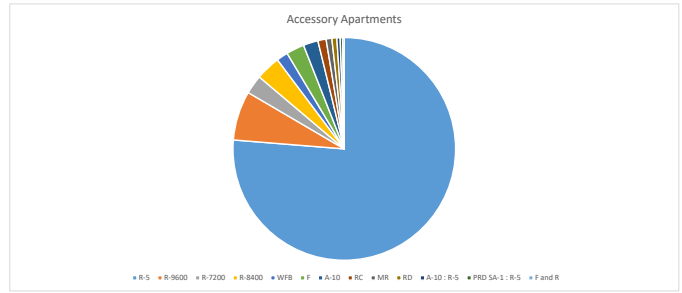
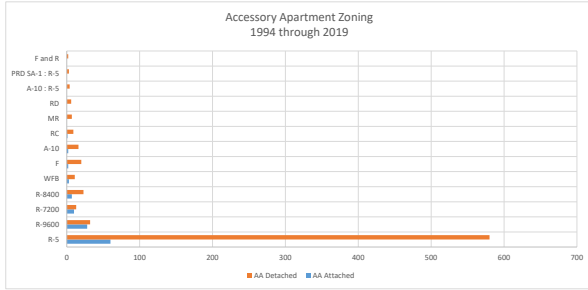







# Accessory Dwelling Units

Index # - File Name: 1.0021 - Accessory Apartment Data\_Snohomish County.pdf

R-7,200	2
Southwest County UGA	2
WFB	2
Southwest County UGA	2
2001	25
Accessory Apt Attached	3
R-5	3
Not in an Urban Growth /	3
Accessory Apt Detached	22
CITY	1
Marysville UGA	1
R-5	16
Not in an Urban Growth /	16
R-7,200	2
Southwest County UGA	2
R-8,400	1
Southwest County UGA	1
RRT-10	2
Not in an Urban Growth /	2
2002	32
Accessory Apt Attached	3
F	1
Not in an Urban Growth /	1
R-5	1
Not in an Urban Growth /	1
WFB	1
Southwest County UGA	1
Accessory Apt Detached	29
F	1
Not in an Urban Growth /	1
R-5	26
Maltby UGA	1
Not in an Urban Growth /	23
Southwest County UGA	2
RRT-10	2
Not in an Urban Growth /	2
2003	40
Accessory Apt Attached	9
CITY	1
Lake Stevens UGA	1
R-5	4
Not in an Urban Growth /	4
R-7,200	1
Southwest County UGA	1
R-9,600	3
Southwest County UGA	3
Accessory Apt Detached	31
CITY	3
Lake Stevens UGA	2
Marysville UGA	1
NULL	6
NULL	6
R-5	19
Granite Falls UGA	1
Not in an Urban Growth /	18
R-8,400	1
Southwest County UGA	1
R-9,600	2
Southwest County UGA	2
2004	74
Accessory Apt Attached	11
A-10	1
Not in an Urban Growth /	1
CITY	1
Marysville UGA	1
R-5	7
Not in an Urban Growth /	7
R-8,400	2
Southwest County UGA	2
Accessory Apt Detached	63
A-10	1
Not in an Urban Growth /	1
A-10 : F : R-5	1
Not in an Urban Growth /	1
CITY	1
Marysville UGA	1
F	2
Not in an Urban Growth /	2
MR	2
Southwest County UGA	2
NULL	3
NULL	3
R-5	46
Not in an Urban Growth /	46
R-8,400	2
Southwest County UGA	2
R-9,600	4
Southwest County UGA	2
Stanwood UGA	2
RRT-10	1
Not in an Urban Growth /	1
2005	101
Accessory Apt Attached	7
CITY	1
Lake Stevens UGA	1
R-5	5
Not in an Urban Growth /	5
R-9,600	1
Southwest County UGA	1
Accessory Apt Detached	94
A-10	2
Not in an Urban Growth /	2
A-10 : CITY	1
Monroe UGA	1
A-10 : F	1
Not in an Urban Growth /	1
A-10 : R-5	2
Not in an Urban Growth /	2
CITY	2
Monroe UGA	1
Southwest County UGA	1
F	3
Not in an Urban Growth /	3
NULL	1
NULL	1
PRD SA-1 : R-5	1
Not in an Urban Growth /	1
R-5	69

# Accessory Dwelling Units

Index # - File Name: 1.0021 - Accessory Apartment Data\_Snohomish County.pdf

	Gold Bar UGA	1
	Granite Falls UGA	1
	Maltby UGA	1
	Not in an Urban Growth /	66
	R-9,600	5
	Southwest County UGA	4
	Stanwood UGA	1
	RRT-10	6
	Not in an Urban Growth /	6
	WFB	1
	Southwest County UGA	1
2006		75
	Accessory Apt Attached	2
	F	1
	Not in an Urban Growth /	1
	NULL	1
	NULL	1
	Accessory Apt Detached	73
	A-10	3
	Not in an Urban Growth /	3
	CITY	3
	Lake Stevens UGA	2
	Marysville UGA	1
	F	1
	Not in an Urban Growth /	1
	NULL	5
	NULL	5
	R-5	54
	Gold Bar UGA	1
	Marysville UGA	2
	Not in an Urban Growth /	51
	R-8,400	2
	Southwest County UGA	2
	RC	2
	Not in an Urban Growth /	2
	RRT-10	1
	Not in an Urban Growth /	1
	WFB	2
	Southwest County UGA	2
2007		58
	Accessory Apt Attached	10
	R-5	8
	Not in an Urban Growth /	8
	R-8,400	1
	Southwest County UGA	1
	R-9,600	1
	Southwest County UGA	1
	Accessory Apt Detached	48
	A-10 : R-5 : RC	1
	Not in an Urban Growth /	1
	CITY	1
	Marysville UGA	1
	F	2
	Not in an Urban Growth /	2
	F and R	2
	Not in an Urban Growth /	2
	R-5	33
	Not in an Urban Growth /	33
	R-9,600	2
	Southwest County UGA	2
	RC	2
	Not in an Urban Growth /	2
	RD	2
	Not in an Urban Growth /	2
	WFB	3
	Southwest County UGA	3
2008		60
	Accessory Apt Attached	6
	A-10	1
	Not in an Urban Growth /	1
	PRD-9,600	2
	Southwest County UGA	2
	R-5	3
	Not in an Urban Growth /	3
	Accessory Apt Detached	54
	A-10	1
	Not in an Urban Growth /	1
	NULL	1
	NULL	1
	PRD SA-1 : R-5	2
	Not in an Urban Growth /	2
	R-5	44
	Not in an Urban Growth /	44
	R-7,200	2
	Lake Stevens UGA	2
	RD	2
	Not in an Urban Growth /	2
	RRT-10	1
	Not in an Urban Growth /	1
	WFB	1
	Southwest County UGA	1
2009		54
2010		57
2011		38
2012		25
2013		17
2014		30
2015		30
2016		32
2017		44
2018		66
2019		52
2020		7
Grand Total		1088

Accessory Dwelling Units

Index # - File Name: 1.0021 - Accessory Apartment Data\_Snohomish County.pdf

PropertyRoll	PropSID1	holders	FPN	In Date	In Year	Issue or Approval Date	Folder Status	Sub	Work	Zoning	Zoning Desc	LGA	Municipal LGA
270817-003-020-00	27081700302000	550890	05 12623 AA	10/24/2005	2005	1/26/2006	Approved	Accessory Apt Detached	Conversion	PRD SA-1 R-5	Rural 5-Acre - Suburban Agriculture-1 Acre	Not in an Urban Growth Area	Not in a Municipal Urban Growth Area
320810-000-018-00	32081000001800	597451	07 11364 AA	10/2/2007	2007	2/12/2008	Approved	Accessory Apt Detached	New	RD	Rural Diversification	Not in an Urban Growth Area	Not in a Municipal Urban Growth Area
320810-000-018-00	32081000001800	598883	07 112843 000 01 RK	10/26/2007	2007	10/12/2008	Closed	Accessory Apt Detached	New	RD	Rural Diversification	Not in an Urban Growth Area	Not in a Municipal Urban Growth Area
320802-003-011-00	32080200301100	698628	08 105424 AA	5/28/2008	2008	6/26/2008	Approved	Accessory Apt Detached	New	RD	Rural Diversification	Not in an Urban Growth Area	Not in a Municipal Urban Growth Area
320802-003-011-00	32080200301100	698630	08 105426 000 01 RK	5/28/2008	2008	3/24/2010	Closed	Accessory Apt Detached	New	RD	Rural Diversification	Not in an Urban Growth Area	Not in a Municipal Urban Growth Area
270510-001-001-00	27051000100100	696673	08 106230 AA	8/31/2008	2008	7/28/2008	Approved	Accessory Apt Detached	Conversion	PRD SA-1 R-5	Rural 5-Acre - Suburban Agriculture-1 Acre	Not in an Urban Growth Area	Not in a Municipal Urban Growth Area
007076-000-310-00	00707600031000	630621	08 106980 AA	7/16/2008	2008	9/4/2008	Approved	Accessory Apt Attached	New	PRD-9-600	Residential 9,600 sq. ft.	Southwest County LGA	MILL CREEK MUGA
007076-000-310-00	00707600031000	630621	08 106984 RK	7/16/2008	2008	9/18/2008	Closed	Accessory Apt Attached	New	PRD-9-600	Residential 9,600 sq. ft.	Southwest County LGA	MILL CREEK MUGA
270510-003-001-00	27051000300100	611350	08 107357 RK	8/5/2008	2008	8/12/2008	Closed	Accessory Apt Detached	Other	PRD SA-1 R-5	Rural 5-Acre - Suburban Agriculture-1 Acre	Not in an Urban Growth Area	Not in a Municipal Urban Growth Area
009041-000-019-00	00904100001900	632710	10 103223 RK	8/3/2010	2010	7/16/2010	Closed	Accessory Apt Attached	Conversion	PRD-8-400	Residential 8,400 sq. ft.	Southwest County LGA	LYNNWOOD MUGA
009041-000-019-00	00904100001900	632711	10 103226 AA	8/3/2010	2010	8/8/2010	Approved	Accessory Apt Attached	Conversion	PRD-8-400	Residential 8,400 sq. ft.	Southwest County LGA	LYNNWOOD MUGA
320908-001-006-00	32090800100600	636441	10 106087 RK	8/18/2010	2010	10/20/2010	Closed	Accessory Apt Detached	New	RD	Rural Diversification	Not in an Urban Growth Area	Not in a Municipal Urban Growth Area
320908-001-006-00	32090800100600	636442	10 106089 AA	8/18/2010	2010	10/8/2010	Approved	Accessory Apt Detached	New	RD	Rural Diversification	Not in an Urban Growth Area	Not in a Municipal Urban Growth Area
007613-000-004-00	00761300000400	780234	18 103089 ACUP	3/25/2019	2019	5/2/2019	Approved w/ Conditions	Standard-AA	New	PRD-SA-1	Suburban Agriculture-1 Acre	Southwest County LGA	MILL CREEK MUGA
007613-000-004-00	00761300000400	780763	18 104343 RK	3/26/2019	2019	7/2/2019	Issued	Accessory Apt Detached	New	PRD-SA-1	Suburban Agriculture-1 Acre	Southwest County LGA	MILL CREEK MUGA
011664-000-016-00	01166400001600	801729	18 113304 ACUP	10/17/2019	2019	12/10/2019	Approved w/ Conditions	Standard-AA	New	R-7-200(PRD)	Residential 7,200 sq. ft.	Southwest County LGA	BOTHELL MUGA
011664-000-016-00	01166400001600	803731	18 113306 RK	10/15/2019	2019	3/10/2020	Issued	Accessory Apt Attached	New	R-7-200(PRD)	Residential 7,200 sq. ft.	Southwest County LGA	BOTHELL MUGA

Accessory Dwelling Units

Index # - File Name: 1.0022 - Single Family Dwellings Data\_Snohomish County.pdf

	Accessory Apartments		1996-2011 Single Family Dwellings			Accessory /	
	Total	Per year	Total	Per year	AA % of total		
Urban Growth Areas	139		9	22315	1395	0.62%	47
Rural and Resource	606		38	10219	639	5.60%	100
Other Zones				657	41		

Accessory Dwelling Units

Index # - File Name: 1.0022 - Single Family Dwellings Data\_Snohomish County.pdf

Apartments	2012-2019				1996-2019		
	Single Family Dwellings				Accessory Apartments		Single Famil
				Total	Per Year	Total	
6	5910	739	0.79%	186	7.75	28225	
13	2916	365	3.32%	706	29.42	13135	
	53	7	0.00%				

Accessory Dwelling Units

Index # - File Name: 1.0022 - Single Family Dwellings Data\_Snohomish County.pdf

ly Dwellings

Per year	AA % of total
1176	0.65%
547	5.10%

Accessory Dwelling Units

Index # - File Name: 1.0022 - Single Family Dwellings Data\_Snohomish County.pdf

Count of PFN

Row Labels

Agriculture-10 Acre

Agriculture-10 Acre : City

Agriculture-10 Acre : City : Rural-5 Acre

Agriculture-10 Acre : Forestry

Agriculture-10 Acre : Forestry : Rural-5 Acre

Agriculture-10 Acre : Industrial Park

Agriculture-10 Acre : Residential 9,600 sq. ft.

Agriculture-10 Acre : Rural Conservation : Rural-5 Acre

Agriculture-10 Acre : Rural Resource Transition-10 Acre

Agriculture-10 Acre : Rural-5 Acre

Agriculture-10 Acre, Sending Area

Business Park

Business Park : Low Density Multiple Residential : Residential 7,200 sq. ft.

Business Park : Multiple Residential

City

City : Residential 7,200 sq. ft. : Residential 9,600 sq. ft.

City : Residential 9,600 sq. ft.

City : Rural-5 Acre

Clearview Rural Commercial

Clearview Rural Commercial : Rural-5 Acre

Community Business

Forestry

Forestry : Mineral Conservation : Rural Conservation : Rural-5 Acre

Forestry : Rural Conservation

Forestry : Rural Diversification

Forestry : Rural-5 Acre

Forestry and Recreation

Forestry and Recreation : Rural-5 Acre

Forestry and Recreation-Off Road Vehicle : Rural Conservation : Rural-5 Acre

General Commercial

Heavy Industrial

Industrial Park

Low Density Multiple Residential

Low Density Multiple Residential : Multiple Residential

Low Density Multiple Residential : Multiple Residential : Residential 8,400 sq. ft.

Low Density Multiple Residential : Neighborhood Business : Residential 9,600 sq. ft.

Low Density Multiple Residential : Planned Community Business : Residential 7,200 sq. ft.

Low Density Multiple Residential : Residential 20,000 sq. ft.

Low Density Multiple Residential : Residential 7,200 sq. ft.

Low Density Multiple Residential : Residential 7,200 sq. ft. : Residential 9,600 sq. ft.

Low Density Multiple Residential : Residential 8,400 sq. ft.

Low Density Multiple Residential : Residential 9,600 sq. ft.

Low Density Multiple Residential : Residential 9,600 sq. ft. : Townhouse



Accessory Dwelling Units

Index # - File Name: 1.0022 - Single Family Dwellings Data\_Snohomish County.pdf

Mineral Conservation
Mobile Home Park
Mobile Home Park : Multiple Residential
Multiple Residential
Multiple Residential : Residential 7,200 sq. ft.
Multiple Residential : Residential 8,400 sq. ft.
Multiple Residential : Residential 9,600 sq. ft.
Native American Land
Neighborhood Business
Neighborhood Business : Residential 9,600 sq. ft.
Neighborhood Business : Rural-5 Acre
Planned Community Business
Residential 12,500 sq. ft.
Residential 20,000 sq. ft.
Residential 20,000 sq. ft. : Rural-5 Acre
Residential 7,200 sq. ft.
Residential 7,200 sq. ft. : Residential 8,400 sq. ft.
Residential 7,200 sq. ft. : Residential 8,400 sq. ft. : Residential 9,600 sq. ft.
Residential 7,200 sq. ft. : Residential 9,600 sq. ft.
Residential 7,200 sq. ft. : Rural Conservation
Residential 7,200 sq. ft. : Rural-5 Acre
Residential 8,400 sq. ft.
Residential 8,400 sq. ft. : Residential 9,600 sq. ft.
Residential 8,400 sq. ft. : Waterfront Beach
Residential 9,600 sq. ft.
Residential 9,600 sq. ft. : Rural-5 Acre
Rural Business
Rural Business : Rural-5 Acre
Rural Conservation
Rural Conservation : Rural-5 Acre
Rural Diversification
Rural Resource Transition-10 Acre
Rural Resource Transition-10 Acre : Rural-5 Acre
Rural-5 Acre
Rural-5 Acre : Suburban Agriculture-1 Acre
Suburban Agriculture-1 Acre
Townhouse
Urban Center
Waterfront Beach
(blank)
Grand Total
Other Zones
Rural and Resource Zones
Urban Growth Areas



Accessory Dwelling Units

Index # - File Name: 1.0022 - Single Family Dwellings Data\_Snohomish County.pdf

							1								
	2	1	2	29	1	2	2			1	1	1	1	1	
	3	12	3	20	9		6	35	42	4	40	182	154	61	
			1												
		2	1		1		1	1	1	3			1		
	1	14	6	1					2			1			
								1							
												1			
1	3	5	12	9	5	2	3	3	1	1	5	11	7	1	
	1	2	70	26	8	2	5		3	3	108	50	7	5	
		1													
1	26	57	100	138	296	371	415	387	309	711	964	862	512	237	
		1	2	1		2	2						1		
									1						
									1			30		3	
6	14	128	120	51	43	97	106	113	23	39	1	6	6	12	
	1		1	2			1		1						
					1						2				
1	89	462	538	763	798	617	658	624	521	616	534	193	123	67	
							1		1						
			4	2	1										
3	1	3	7	11	23	29	3	2	7	12	6	4	5	2	
		1		3		1		1		1					
	3	6	11	8	17	13	7	12	10	17	11	13	7	6	
	19	22	22	29	26	21	16	24	43	35	97	69	20	10	
					1		1								
21	245	601	734	892	741	562	627	632	642	754	712	608	557	236	
					2					1	1			2	
	3	32	24	33	45	30	24	24	15	7	3	2	1	2	
		14		12	1										
		1		11	13	1	1	1		1		25	1	12	
				4	1	6	2	5	5	4	6	1	3	4	
		2			2	1	1	1	1	4	7	2	1	1	
48	622	1955	2292	2676	2706	2331	2164	2463	2317	2797	3433	2594	1774	909	
<b>1994</b>	<b>1995</b>	<b>1996</b>	<b>1997</b>	<b>1998</b>	<b>1999</b>	<b>2000</b>	<b>2001</b>	<b>2002</b>	<b>2003</b>	<b>2004</b>	<b>2005</b>	<b>2006</b>	<b>2007</b>	<b>2008</b>	
1	7	40	106	72	59	40	34	32	24	15	122	64	18	12	
26	295	685	827	1007	866	668	699	721	746	861	884	749	648	287	
21	320	1228	1359	1597	1779	1622	1430	1709	1546	1917	2420	1779	1107	609	

Accessory Dwelling Units

Index # - File Name: 1.0022 - Single Family Dwellings Data\_Snohomish County.pdf

2009	2010	2011	2012	2013	2014	2015	2016	2017	2018	2019	2020	Grand Total
5	4	1	4	6	11	5	12	4	10	5	5	255
					1				1			2
												1
								1				2
												1
												1
												1
												1
	1				1							2
					1		2	1		1	1	47
												1
										26	1	27
								14				14
									8			8
211	56	31	14			24		1		24		6025
								1				1
											2	4
								1				2
							1					1
												1
								1				1
9	8	6	10	2	14	9	12	12	21	8	1	519
												1
												5
												3
						3			1			11
				1			1			1		14
2												6
												1
				1								1
												3
												1
93	66	57	65	122	44	5	4	28	67	132	72	1955
												2
									5			5
							45					45
									25			25
												7
						12	9	88	10	30	5	156
							31	32				63
						1	6	11	6			24
								21				22
									11			11

Accessory Dwelling Units

Index # - File Name: 1.0022 - Single Family Dwellings Data\_Snohomish County.pdf

							1					2	
			3	5	1	1	9			15	5	83	
								25				25	
60	34	35	35	2	7	9	59	142	53	54	10	1071	
								5				6	
							8	6	5	11		30	
												1	
												11	
				1			6	7				39	
								29				29	
												1	
												1	
	1	1	2			1	1	1	3		1	4	84
		1	1	2	2		1	3	3	4	6		313
								1			1		3
328	426	555	581	499	465	515	448	482	278	290	198		10451
								19	8				27
										2			2
							4	15	17	5			50
								1					2
													34
	1	6	8	55	36	17	26	66	38	20	5	2	1045
							1	4					11
													3
96	59	90	75	21	115	113	97	124	28	16	24		7462
													2
			1					1					9
								1					1
			1	1	2	2		2		3	1	1	131
			1		2			1		1			12
4	4	5	4	4	2	1	1		4	6	1		177
7	5	4		7	5	5	17	8	10	3	3		527
													2
134	206	165	182	243	250	314	431	437	416	385	244		11971
													6
	1			2	2	1		1		3	2		257
													27
	1												68
	3	8	1	3	7	2		3			2		70
	1	2	8				3			3	9		49
955	887	964	1044	963	943	1068	1326	1526	1008	1015	593		43373
<b>2009</b>	<b>2010</b>	<b>2011</b>	<b>2012</b>	<b>2013</b>	<b>2014</b>	<b>2015</b>	<b>2016</b>	<b>2017</b>	<b>2018</b>	<b>2019</b>	<b>2020</b>	<b>Grand Total</b>	
5	10	4	5	11	5	3	7	8	4	10	9		
161	228	182	203	265	289	337	482	463	467	410	256		
789	648	776	828	687	649	725	837	1055	537	592	319		

Accessory Dwelling Units

Index # - File Name: 1.0022 - Single Family Dwellings Data\_Snohomish County.pdf

PFN	Zone_Short	Zoning	Sub
94 140470 RK	R-5	Rural-5 Acre	SFR-Basic
94 140771 RK	R-9,600	Residential 9,600 sq. ft.	Single Family Res-Combo
94 240331 RK	F	Forestry	SFR-Basic
94 321449 MH	R-8,400	Residential 8,400 sq. ft.	Double Wide
94 140476 RK	R-12,500	Residential 12,500 sq. ft.	Single Family Res-Combo
94 140392 RK	R-5	Rural-5 Acre	Single Family Res-Combo
94 135239 RK	R-8,400	Residential 8,400 sq. ft.	Single Family Res-Combo
94 241561 MH	R-5	Rural-5 Acre	Double Wide
94 140452 RK	R-5	Rural-5 Acre	Single Family Res-Combo
94 140453 RK	R-5	Rural-5 Acre	Single Family Res-Combo
94 140382 RK	CITY	City	Single Family Res-Combo
94 140677 RK	R-5	Rural-5 Acre	Single Family Res-Combo
93 140049 MH	RC	Rural Conservation	Double Wide
94 134998 RK	R-5	Rural-5 Acre	Single Family Res-Combo
94 140310 RK	R-5	Rural-5 Acre	Single Family Res-Combo
94 140472 RK	R-5	Rural-5 Acre	Single Family Res-Combo
93 140793 RK	RC	Rural Conservation	Single Family Res-Combo
94 134720 RK	R-5	Rural-5 Acre	Single Family Res-Combo
94 140320 RK	R-5	Rural-5 Acre	Single Family Res-Combo
94 140356 RK	R-7,200	Residential 7,200 sq. ft.	Single Family Res-Combo
94 131452 MH	R-5	Rural-5 Acre	Double Wide
94 140455 RK	RC	Rural Conservation	Single Family Res-Combo
94 140269 RK	F	Forestry	Single Family Res-Combo
94 140870 RK	CITY	City	Single Family Res-Combo
94 241597 RK	PRD-LDMR	Low Density Multiple Reside	SFR-Basic
94 241598 RK	PRD-LDMR	Low Density Multiple Reside	SFR-Basic
94 241596 RK	PRD-LDMR	Low Density Multiple Reside	SFR-Basic
94 241600 RK	PRD-LDMR	Low Density Multiple Reside	SFR-Basic
94 140428 MH	R-5	Rural-5 Acre	Double Wide
94 135057 RK	R-5	Rural-5 Acre	Single Family Res-Combo
94 140336 RK	R-5	Rural-5 Acre	Single Family Res-Combo
94 140480 RK	R-5	Rural-5 Acre	Single Family Res-Combo
94 140463 RK	R-8,400	Residential 8,400 sq. ft.	Single Family Res-Combo
94 140464 RK	R-8,400	Residential 8,400 sq. ft.	Single Family Res-Combo
94 140465 RK	R-8,400	Residential 8,400 sq. ft.	Single Family Res-Combo
94 140466 RK	R-8,400	Residential 8,400 sq. ft.	Single Family Res-Combo
94 140387 RK	R-5	Rural-5 Acre	Single Family Res-Combo
94 140431 RK	R-5	Rural-5 Acre	Single Family Res-Combo
94 240200 RK	CITY	City	SFR-Basic
94 240220 RK	CITY	City	SFR-Basic
94 240216 RK	CITY	City	SFR-Basic
94 240206 RK	CITY	City	SFR-Basic
94 240213 RK	CITY	City	SFR-Basic
94 240202 RK	CITY	City	SFR-Basic
94 140473 MH	R-5	Rural-5 Acre	Double Wide
93 130467 000 01 RK	R-5	Rural-5 Acre	Single Family Res-Combo

Accessory Dwelling Units

Index # - File Name: 1.0022 - Single Family Dwellings Data\_Snohomish County.pdf

94 135587 MH	CITY	City	MH Park-Double Wide
94 122278 RK	R-5	Rural-5 Acre	Single Family Res-Combo
95 108779 RK	R-8,400	Residential 8,400 sq. ft.	Duplex-Combo
95 102552 RK	R-5	Rural-5 Acre	Single Family Res-Combo
95 109595 RK	R-9,600	Residential 9,600 sq. ft.	Single Family Res-Combo
95 109355 RK	R-9,600	Residential 9,600 sq. ft.	Single Family Res-Combo
95 109381 RK	LDMR	Low Density Multiple Reside	Single Family Res-Combo
95 109384 RK	LDMR	Low Density Multiple Reside	Single Family Res-Combo
95 109383 RK	LDMR	Low Density Multiple Reside	Single Family Res-Combo
95 109378 MH	NB	Neighborhood Business	
95 109459 RK	R-5	Rural-5 Acre	Single Family Res-Combo
95 109674 MH	R-5	Rural-5 Acre	Double Wide
95 108476 RK	R-5	Rural-5 Acre	Single Family Res-Combo
95 109721 RK	CITY	City	Single Family Res-Combo
95 106909 RK	CITY	City	Single Family Res-Combo
95 110871 MH	CITY	City	MH Park-Double Wide
95 108032 RK	CITY	City	Single Family Res-Combo
95 110172 MH	R-5	Rural-5 Acre	Single Wide
95 106912 RK	CITY	City	Single Family Res-Combo
95 110609 MH	F	Forestry	Double Wide
95 108147 RK	CITY	City	Duplex-Combo
95 109874 MH	CITY	City	MH Park-Double Wide
95 102709 RK	R-5	Rural-5 Acre	Single Family Res-Combo
94 140751 RK	A-10	Agriculture-10 Acre	Single Family Res-Combo
94 241571 RK	R-5	Rural-5 Acre	Single Family Res-Combo
94 240231 RK	R-5	Rural-5 Acre	Single Family Res-Combo
94 240323 RK	R-5	Rural-5 Acre	Single Family Res-Combo
95 106224 RK	R-5	Rural-5 Acre	Single Family Res-Combo
95 107716 RK	R-5	Rural-5 Acre	Single Family Res-Combo
94 140434 RK	R-5	Rural-5 Acre	Single Family Res-Combo
94 140450 MH	RD	Rural Diversification	Single Wide
95 103637 MH	RRT-10	Rural Resource Transition-10	Double Wide
94 140834 RK	R-9,600	Residential 9,600 sq. ft.	Single Family Res-Combo
94 140783 RK	R-5	Rural-5 Acre	Duplex-Combo
95 102903 RK	R-5	Rural-5 Acre	Single Family Res-Combo
94 321462 RK	CITY	City	SFR-Basic
94 240209 RK	CITY	City	SFR-Basic
94 321452 RK	CITY	City	SFR-Basic
94 140442 RK	R-5	Rural-5 Acre	Single Family Res-Combo
94 140394 MH	R-5	Rural-5 Acre	Double Wide
95 109509 RK	R-5	Rural-5 Acre	Single Family Res-Combo
94 140437 RK	R-5	Rural-5 Acre	Single Family Res-Combo
94 140460 RK	MR	Multiple Residential	Single Family Res-Combo
94 140672 MH	R-5	Rural-5 Acre	Double Wide
95 102856 RK	R-5	Rural-5 Acre	Single Family Res-Combo
95 106579 RK	R-9,600	Residential 9,600 sq. ft.	Single Family Res-Combo
94 140278 RK	R-9,600	Residential 9,600 sq. ft.	Single Family Res-Combo

Accessory Dwelling Units

Index # - File Name: 1.0022 - Single Family Dwellings Data\_Snohomish County.pdf

94 140808 RK	R-9,600	Residential 9,600 sq. ft.	Single Family Res-Combo
94 140486 RK	R-9,600	Residential 9,600 sq. ft.	Single Family Res-Combo
94 140811 RK	F	Forestry	Single Family Res-Combo
94 240322 RK	CITY	City	SFR-Basic
94 321471 RK	CITY	City	SFR-Basic
95 102904 RK	R-7,200	Residential 7,200 sq. ft.	Single Family Res-Combo
94 140390 RK	R-5	Rural-5 Acre	Single Family Res-Combo
95 106544 RK	R-5	Rural-5 Acre	Single Family Res-Combo
94 140299 MH	R-5	Rural-5 Acre	Double Wide
95 107865 RK	R-5	Rural-5 Acre	Single Family Res-Combo
95 103762 RK	R-7,200	Residential 7,200 sq. ft.	SFR-Basic
94 140785 RK	R-8,400	Residential 8,400 sq. ft.	Single Family Res-Combo
94 140374 RK	R-5	Rural-5 Acre	Single Family Res-Combo
95 103964 RK	R-9,600	Residential 9,600 sq. ft.	SFR-Basic
95 100030 RK	R-9,600	Residential 9,600 sq. ft.	SFR-Basic
95 103968 RK	R-9,600	Residential 9,600 sq. ft.	SFR-Basic
94 140386 RK	R-5	Rural-5 Acre	Single Family Res-Combo
94 140345 RK	R-5	Rural-5 Acre	Single Family Res-Combo
94 140787 RK	R-8,400	Residential 8,400 sq. ft.	Single Family Res-Combo
94 140483 RK	R-8,400	Residential 8,400 sq. ft.	Single Family Res-Combo
94 140485 RK	R-8,400	Residential 8,400 sq. ft.	Single Family Res-Combo
95 101534 RK	CITY	City	Single Family Res-Combo
95 101532 RK	CITY	City	Single Family Res-Combo
95 101538 RK	CITY	City	Single Family Res-Combo
95 101539 RK	CITY	City	Single Family Res-Combo
95 101541 RK	CITY	City	Single Family Res-Combo
95 101543 RK	CITY	City	Single Family Res-Combo
95 101545 RK	CITY	City	Single Family Res-Combo
95 101550 RK	CITY	City	Single Family Res-Combo
95 101546 RK	CITY	City	Single Family Res-Combo
95 102643 RK	CITY	City	Single Family Res-Combo
95 101549 RK	CITY	City	Single Family Res-Combo
94 140313 RK	R-5	Rural-5 Acre	Single Family Res-Combo
95 104000 RK	R-5	Rural-5 Acre	Single Family Res-Combo
95 108055 RK	R-5	Rural-5 Acre	Single Family Res-Combo
94 321463 RK	R-5	Rural-5 Acre	Single Family Res-Combo
94 241646 RK	R-5	Rural-5 Acre	Single Family Res-Combo
95 108607 RK	R-5	Rural-5 Acre	Single Family Res-Combo
95 100161 RK	R-5	Rural-5 Acre	Single Family Res-Combo
94 140263 RK	CITY	City	Single Family Res-Combo
94 140268 RK	CITY	City	Single Family Res-Combo
95 108141 RK	CITY	City	Single Family Res-Combo
95 108140 RK	CITY	City	Single Family Res-Combo
95 100576 RK	CITY	City	Single Family Res-Combo
95 100423 RK	CITY	City	Single Family Res-Combo
95 101812 RK	CITY	City	Single Family Res-Combo
95 101814 RK	CITY	City	Single Family Res-Combo



Accessory Dwelling Units

Index # - File Name: 1.0022 - Single Family Dwellings Data\_Snohomish County.pdf

95 101144 RK	CITY	City	SFR-Basic
95 101138 RK	CITY	City	SFR-Basic
95 101816 RK	CITY	City	Single Family Res-Combo
94 240294 RK	CITY	City	Single Family Res-Combo
94 240295 RK	CITY	City	Single Family Res-Combo
95 103696 RK	CITY	City	SFR-Basic
95 101774 RK	CITY	City	SFR-Basic
95 101770 RK	CITY	City	SFR-Basic
95 103707 RK	CITY	City	SFR-Basic
95 103711 RK	CITY	City	SFR-Basic
95 103713 RK	CITY	City	SFR-Basic
95 103716 RK	CITY	City	SFR-Basic
95 103701 RK	CITY	City	SFR-Basic
95 101767 RK	CITY	City	SFR-Basic
95 101762 RK	CITY	City	SFR-Basic
94 240348 RK	R-5	Rural-5 Acre	Single Family Res-Combo
95 105042 RK	PRD-9,600	Residential 9,600 sq. ft.	Single Family Res-Combo
95 103626 RK	PRD-9,600	Residential 9,600 sq. ft.	Single Family Res-Combo
95 103628 RK	PRD-9,600	Residential 9,600 sq. ft.	Single Family Res-Combo
95 103482 RK	PRD-9,600	Residential 9,600 sq. ft.	Single Family Res-Combo
95 102963 RK	PRD-9,600	Residential 9,600 sq. ft.	Single Family Res-Combo
93 130493 000 01 RK	RD	Rural Diversification	Single Family Res-Combo
95 107771 MH	R-5	Rural-5 Acre	Double Wide
95 100655 RK	R-5	Rural-5 Acre	SFR-Basic
95 102516 RK	R-8,400	Residential 8,400 sq. ft.	Single Family Res-Combo
95 102513 RK	R-8,400	Residential 8,400 sq. ft.	Single Family Res-Combo
95 107954 RK	R-9,600	Residential 9,600 sq. ft.	Single Family Res-Combo
94 140259 MH	R-5	Rural-5 Acre	Double Wide
94 140456 RK	R-5	Rural-5 Acre	Single Family Res-Combo
95 105392 RK	PRD-LDMR	Low Density Multiple Reside	Single Family Res-Combo
95 105394 RK	PRD-LDMR	Low Density Multiple Reside	Single Family Res-Combo
95 105395 RK	PRD-LDMR	Low Density Multiple Reside	Single Family Res-Combo
94 140321 RK	R-5	Rural-5 Acre	Single Family Res-Combo
94 140916 MH	R-5	Rural-5 Acre	Double Wide
95 108818 RK	PRD-9,600	Residential 9,600 sq. ft.	Single Family Res-Combo
95 101278 RK	PRD-9,600	Residential 9,600 sq. ft.	SFR-Basic
95 105771 RK	LDMR	Low Density Multiple Reside	Duplex-Combo
94 140354 RK	R-5	Rural-5 Acre	Single Family Res-Combo
94 140795 RK	R-5	Rural-5 Acre	Single Family Res-Combo
95 106430 RK	R-5	Rural-5 Acre	Single Family Res-Combo
95 101022 MH	R-5	Rural-5 Acre	Single Wide
94 140272 RK	R-5	Rural-5 Acre	Single Family Res-Combo
95 108352 RK	LDMR	Low Density Multiple Reside	Duplex-Basic
95 108354 RK	LDMR	Low Density Multiple Reside	Duplex-Basic
94 140349 MH	R-5	Rural-5 Acre	Double Wide
95 102497 RK	R-5	Rural-5 Acre	SFR-Basic
95 105935 RK	PRD-LDMR	Low Density Multiple Reside	Single Family Res-Combo

Accessory Dwelling Units

Index # - File Name: 1.0022 - Single Family Dwellings Data\_Snohomish County.pdf

95 106970 RK	CITY	City	Single Family Res-Combo
95 106969 RK	CITY	City	Single Family Res-Combo
95 109734 RK	CITY	City	SFR-Basic
95 109730 RK	CITY	City	SFR-Basic
94 140221 RK	A-10 : R-5	Agriculture-10 Acre : Rural-5	Single Family Res-Combo
94 140427 MH	R-5	Rural-5 Acre	Double Wide
94 140857 RK	R-5	Rural-5 Acre	Single Family Res-Combo
94 140275 RK	R-5	Rural-5 Acre	Single Family Res-Combo
95 104766 RK	CITY	City	SFR-Basic
95 104769 RK	CITY	City	SFR-Basic
95 100291 RK	CITY	City	SFR-Basic
95 100303 RK	CITY	City	SFR-Basic
95 100299 RK	CITY	City	SFR-Basic
95 106971 RK	CITY	City	Single Family Res-Combo
95 108572 RK	CITY	City	SFR-Basic
95 107735 RK	R-9,600	Residential 9,600 sq. ft.	Single Family Res-Combo
95 104004 RK	R-5	Rural-5 Acre	Single Family Res-Combo
94 140631 MH	F and R	Forestry and Recreation	Single Wide
95 110059 MH	CITY	City	Double Wide
94 140493 MH	CITY	City	Double Wide
95 108209 RK	R-9,600	Residential 9,600 sq. ft.	SFR-Basic
94 140407 RK	R-8,400 : R-9,600	Residential 8,400 sq. ft. : Residential 9,600 sq. ft.	Single Family Res-Combo
94 140398 RK	CITY	City	Single Family Res-Combo
94 140184 RK	R-5	Rural-5 Acre	Single Family Res-Combo
95 106341 RK	PRD-9,600	Residential 9,600 sq. ft.	Single Family Res-Combo
95 106340 RK	PRD-9,600	Residential 9,600 sq. ft.	Single Family Res-Combo
95 106431 RK	PRD-9,600	Residential 9,600 sq. ft.	Single Family Res-Combo
94 140197 MH	R-5	Rural-5 Acre	Double Wide
95 102679 RK	R-9,600	Residential 9,600 sq. ft.	Single Family Res-Combo
94 140212 RK	R-9,600	Residential 9,600 sq. ft.	Single Family Res-Combo
95 102229 RK	CITY	City	SFR-Basic
95 103100 RK	CITY	City	Single Family Res-Combo
94 241587 RK	CITY	City	SFR-Basic
95 103098 RK	CITY	City	Single Family Res-Combo
95 103096 RK	CITY	City	Single Family Res-Combo
95 104492 RK	CITY	City	Single Family Res-Combo
95 103102 RK	CITY	City	Single Family Res-Combo
95 103103 RK	CITY	City	Single Family Res-Combo
95 104493 RK	CITY	City	Single Family Res-Combo
95 103379 RK	CITY	City	SFR-Basic
95 102692 RK	CITY	City	Single Family Res-Combo
95 101724 RK	CITY	City	SFR-Basic
95 103382 RK	CITY	City	SFR-Basic
95 103977 RK	R-7,200	Residential 7,200 sq. ft.	SFR-Basic
95 103978 RK	R-7,200	Residential 7,200 sq. ft.	SFR-Basic
95 103974 RK	R-7,200	Residential 7,200 sq. ft.	SFR-Basic
95 103980 RK	R-7,200	Residential 7,200 sq. ft.	SFR-Basic

Accessory Dwelling Units

Index # - File Name: 1.0022 - Single Family Dwellings Data\_Snohomish County.pdf

94 140315 RK	F	Forestry	Single Family Res-Combo
95 104767 RK	CITY	City	SFR-Basic
95 101130 RK	R-5	Rural-5 Acre	Single Family Res-Combo
95 101867 RK	R-5	Rural-5 Acre	Single Family Res-Combo
94 140244 RK	CITY	City	Single Family Res-Combo
95 104497 RK	R-5	Rural-5 Acre	Single Family Res-Combo
94 140481 RK	R-5	Rural-5 Acre	Single Family Res-Combo
95 101416 RK	CITY	City	SFR-Basic
95 101420 RK	CITY	City	SFR-Basic
95 101419 RK	CITY	City	SFR-Basic
95 101422 RK	CITY	City	SFR-Basic
95 101417 RK	CITY	City	SFR-Basic
94 140850 RK	CITY	City	Single Family Res-Combo
94 321498 RK	CITY	City	SFR-Basic
94 321496 RK	CITY	City	SFR-Basic
94 321497 RK	CITY	City	SFR-Basic
94 321495 RK	CITY	City	SFR-Basic
94 321493 RK	CITY	City	SFR-Basic
94 321492 RK	CITY	City	SFR-Basic
94 140316 RK	R-5	Rural-5 Acre	Single Family Res-Combo
94 240293 RK	PRD-9,600	Residential 9,600 sq. ft.	Single Family Res-Combo
94 306221 RK	PRD-9,600	Residential 9,600 sq. ft.	Single Family Res-Combo
94 140849 RK	CITY	City	Single Family Res-Combo
95 103603 RK	CITY	City	SFR-Basic
94 240229 RK	R-9,600	Residential 9,600 sq. ft.	SFR-Basic
95 107981 MH	R-12,500	Residential 12,500 sq. ft.	Double Wide
95 107518 RK	R-5	Rural-5 Acre	Single Family Res-Combo
94 140471 RK	CITY	City	Single Family Res-Combo
94 140314 RK	CITY	City	Single Family Res-Combo
94 140237 MH	R-5	Rural-5 Acre	Single Wide
95 106309 RK	RRT-10	Rural Resource Transition-10	Single Family Res-Combo
95 109026 RK	RRT-10	Rural Resource Transition-10	Single Family Res-Combo
95 106312 RK	RRT-10	Rural Resource Transition-10	Single Family Res-Combo
95 105652 MH	RD	Rural Diversification	Triple Wide
94 140435 RK	R-9,600	Residential 9,600 sq. ft.	Single Family Res-Combo
95 101010 RK	R-5	Rural-5 Acre	Single Family Res-Combo
95 101674 RK	R-5	Rural-5 Acre	Single Family Res-Combo
95 102388 RK	R-5	Rural-5 Acre	Single Family Res-Combo
95 102515 RK	F	Forestry	Single Family Res-Combo
94 140366 RK	R-7,200	Residential 7,200 sq. ft.	Single Family Res-Combo
94 140377 RK	R-7,200	Residential 7,200 sq. ft.	Single Family Res-Combo
95 103079 RK	R-20,000	Residential 20,000 sq. ft.	Single Family Res-Combo
94 321477 RK	CITY	City	SFR-Basic
95 100828 RK	R-9,600	Residential 9,600 sq. ft.	SFR-Basic
95 101129 RK	R-5	Rural-5 Acre	Single Family Res-Combo
94 140682 RK	RRT-10	Rural Resource Transition-10	Single Family Res-Combo
95 101838 RK	CITY	City	Single Family Res-Combo

Accessory Dwelling Units

Index # - File Name: 1.0022 - Single Family Dwellings Data\_Snohomish County.pdf

95 109305 RK	RRT-10	Rural Resource Transition-1(Single Family Res-Combo	
95 106299 RK	RRT-10	Rural Resource Transition-1(Single Family Res-Combo	
94 321569 RK	PRD-9,600	Residential 9,600 sq. ft.	SFR-Basic
95 100633 RK	CITY	City	SFR-Basic
94 140391 RK	R-5	Rural-5 Acre	Single Family Res-Combo
94 140359 RK	R-9,600	Residential 9,600 sq. ft.	Single Family Res-Combo
94 140425 RK	R-7,200	Residential 7,200 sq. ft.	Single Family Res-Combo
95 104918 RK	R-7,200	Residential 7,200 sq. ft.	Duplex-Combo
95 104577 MH	R-5	Rural-5 Acre	Double Wide
95 106997 RK	R-5	Rural-5 Acre	Single Family Res-Combo
95 105435 RK	R-5	Rural-5 Acre	Single Family Res-Combo
95 107301 MH	R-5	Rural-5 Acre	Double Wide
95 103806 RK	R-5	Rural-5 Acre	Single Family Res-Combo
94 140369 RK	R-5	Rural-5 Acre	Single Family Res-Combo
95 107948 RK	R-9,600	Residential 9,600 sq. ft.	SFR-Basic
95 106914 RK	R-9,600	Residential 9,600 sq. ft.	Single Family Res-Combo
95 108271 RK	R-9,600	Residential 9,600 sq. ft.	SFR-Basic
95 105608 RK	R-9,600	Residential 9,600 sq. ft.	SFR-Basic
95 110623 RK	R-9,600	Residential 9,600 sq. ft.	Single Family Res-Combo
95 109552 RK	R-9,600	Residential 9,600 sq. ft.	SFR-Basic
95 107942 RK	R-9,600	Residential 9,600 sq. ft.	SFR-Basic
95 107943 RK	R-9,600	Residential 9,600 sq. ft.	SFR-Basic
95 109360 RK	R-9,600	Residential 9,600 sq. ft.	SFR-Basic
95 106947 RK	R-9,600	Residential 9,600 sq. ft.	Single Family Res-Combo
95 107947 RK	R-9,600	Residential 9,600 sq. ft.	SFR-Basic
95 108477 RK	R-9,600	Residential 9,600 sq. ft.	Single Family Res-Combo
95 100705 RK	R-5	Rural-5 Acre	Single Family Res-Combo
95 100704 RK	R-5	Rural-5 Acre	Single Family Res-Combo
95 104238 RK	R-9,600	Residential 9,600 sq. ft.	SFR-Basic
95 101297 RK	CITY	City	Single Family Res-Combo
95 102250 RK	R-5	Rural-5 Acre	Single Family Res-Combo
95 109511 RK	R-5	Rural-5 Acre	Single Family Res-Combo
95 105419 RK	R-5	Rural-5 Acre	Single Family Res-Combo
95 101426 RK	R-5	Rural-5 Acre	Single Family Res-Combo
95 101135 RK	CITY	City	SFR-Basic
95 109056 RK	PRD-9,600	Residential 9,600 sq. ft.	Single Family Res-Combo
95 106083 RK	PRD-9,600	Residential 9,600 sq. ft.	Single Family Res-Combo
95 109747 RK	PRD-9,600	Residential 9,600 sq. ft.	Single Family Res-Combo
95 108311 RK	PRD-9,600	Residential 9,600 sq. ft.	Single Family Res-Combo
95 102724 RK	PRD-9,600	Residential 9,600 sq. ft.	Single Family Res-Combo
95 101723 RK	PRD-9,600	Residential 9,600 sq. ft.	SFR-Basic
95 106313 RK	PRD-9,600	Residential 9,600 sq. ft.	Single Family Res-Combo
95 107367 RK	PRD-9,600	Residential 9,600 sq. ft.	Single Family Res-Combo
95 107727 RK	PRD-9,600	Residential 9,600 sq. ft.	Single Family Res-Combo
95 107020 RK	R-9,600	Residential 9,600 sq. ft.	Single Family Res-Combo
95 103405 RK	R-5	Rural-5 Acre	Single Family Res-Combo
95 102320 MH	R-5	Rural-5 Acre	Single Wide

Accessory Dwelling Units

Index # - File Name: 1.0022 - Single Family Dwellings Data\_Snohomish County.pdf

95 107120 RK	R-5	Rural-5 Acre	Single Family Res-Combo
95 101759 RK	R-9,600	Residential 9,600 sq. ft.	Single Family Res-Combo
95 102726 RK	R-9,600	Residential 9,600 sq. ft.	Single Family Res-Combo
95 109400 RK	R-9,600	Residential 9,600 sq. ft.	Single Family Res-Combo
95 103464 RK	MR	Multiple Residential	Duplex-Combo
95 104613 RK	RRT-10	Rural Resource Transition-10	Single Family Res-Combo
95 108807 RK	CITY	City	Single Family Res-Combo
95 107216 RK	CITY	City	Single Family Res-Combo
95 102407 RK	R-5	Rural-5 Acre	Single Family Res-Combo
95 105086 RK	CITY	City	Single Family Res-Combo
95 105087 RK	CITY	City	Single Family Res-Combo
95 105090 RK	CITY	City	Single Family Res-Combo
95 105091 RK	CITY	City	Single Family Res-Combo
95 105070 RK	RRT-10	Rural Resource Transition-10	Single Family Res-Combo
95 105982 RK	CITY	City	Single Family Res-Combo
95 103801 RK	R-7,200	Residential 7,200 sq. ft.	Single Family Res-Combo
95 104194 RK	R-7,200	Residential 7,200 sq. ft.	SFR-Basic
95 104196 RK	R-7,200	Residential 7,200 sq. ft.	SFR-Basic
95 108732 RK	PRD SA-1	Suburban Agriculture-1 Acre	Single Family Res-Combo
95 108637 RK	PRD SA-1	Suburban Agriculture-1 Acre	Single Family Res-Combo
95 108636 RK	PRD SA-1	Suburban Agriculture-1 Acre	Single Family Res-Combo
95 103197 RK	R-5	Rural-5 Acre	Single Family Res-Combo
95 106784 RK	R-5	Rural-5 Acre	Single Family Res-Combo
95 105618 RK	CITY	City	SFR-Basic
95 105617 RK	CITY	City	SFR-Basic
95 105622 RK	CITY	City	SFR-Basic
95 103193 RK	CITY	City	Single Family Res-Combo
95 107975 RK	CITY	City	SFR-Basic
95 107978 RK	CITY	City	SFR-Basic
95 107983 RK	CITY	City	SFR-Basic
95 105621 RK	CITY	City	SFR-Basic
95 103194 RK	CITY	City	Single Family Res-Combo
95 103203 RK	R-5	Rural-5 Acre	Single Family Res-Combo
95 101377 RK	CITY	City	Single Family Res-Combo
95 100305 RK	CITY	City	Single Family Res-Combo
95 100301 RK	CITY	City	Single Family Res-Combo
95 107376 RK	CITY	City	Single Family Res-Combo
95 101376 RK	CITY	City	Single Family Res-Combo
95 101375 RK	CITY	City	Single Family Res-Combo
95 106602 RK	R-5	Rural-5 Acre	Single Family Res-Combo
95 108143 RK	R-5	Rural-5 Acre	Single Family Res-Combo
95 107342 RK	R-5	Rural-5 Acre	Single Family Res-Combo
95 101962 RK	R-5	Rural-5 Acre	Single Family Res-Combo
95 104353 RK	R-9,600	Residential 9,600 sq. ft.	Single Family Res-Combo
95 106054 RK	R-9,600	Residential 9,600 sq. ft.	Single Family Res-Combo
95 108537 RK	R-9,600	Residential 9,600 sq. ft.	Single Family Res-Combo
95 103890 RK	R-5	Rural-5 Acre	Single Family Res-Combo

Accessory Dwelling Units

Index # - File Name: 1.0022 - Single Family Dwellings Data\_Snohomish County.pdf

95 110035 RK	R-9,600	Residential 9,600 sq. ft.	Single Family Res-Combo
95 105017 RK	R-9,600	Residential 9,600 sq. ft.	Single Family Res-Combo
95 105014 RK	R-9,600	Residential 9,600 sq. ft.	Single Family Res-Combo
95 105016 RK	R-9,600	Residential 9,600 sq. ft.	Single Family Res-Combo
95 107600 RK	CITY	City	Single Family Res-Combo
95 107784 RK	CITY	City	Single Family Res-Combo
95 107610 RK	CITY	City	Single Family Res-Combo
95 109565 RK	CITY	City	Single Family Res-Combo
95 103662 RK	CITY	City	Single Family Res-Combo
95 108119 RK	CITY	City	Single Family Res-Combo
95 108120 RK	CITY	City	Single Family Res-Combo
95 110347 RK	CITY	City	Single Family Res-Combo
95 105900 RK	CITY	City	Single Family Res-Combo
95 108335 RK	CITY	City	SFR-Basic
95 106806 RK	CITY	City	Single Family Res-Combo
95 103649 RK	CITY	City	Single Family Res-Combo
95 103119 RK	R-5	Rural-5 Acre	Single Family Res-Combo
95 106796 RK	CITY	City	Single Family Res-Combo
95 106795 RK	CITY	City	Single Family Res-Combo
95 108323 RK	CITY	City	Single Family Res-Combo
95 106797 RK	CITY	City	Single Family Res-Combo
95 109337 RK	CITY	City	Single Family Res-Combo
95 105748 RK	CITY	City	Single Family Res-Combo
95 104095 MH	R-5	Rural-5 Acre	Double Wide
95 105224 RK	R-5	Rural-5 Acre	Single Family Res-Combo
95 104272 RK	F	Forestry	Single Family Res-Combo
95 104226 RK	CITY	City	Single Family Res-Combo
95 105095 RK	R-5	Rural-5 Acre	Single Family Res-Combo
95 105099 RK	R-5	Rural-5 Acre	Single Family Res-Combo
95 105097 RK	R-5	Rural-5 Acre	Single Family Res-Combo
95 107167 RK	R-5	Rural-5 Acre	Single Family Res-Combo
95 103293 RK	R-5	Rural-5 Acre	Single Family Res-Combo
95 106036 RK	PRD-LDMR	Low Density Multiple Reside	Single Family Res-Combo
95 106035 RK	PRD-LDMR	Low Density Multiple Reside	Single Family Res-Combo
95 106032 RK	PRD-LDMR	Low Density Multiple Reside	Single Family Res-Combo
95 102258 RK	R-5	Rural-5 Acre	Single Family Res-Combo
95 105397 RK	PRD-LDMR	Low Density Multiple Reside	Single Family Res-Combo
95 105398 RK	PRD-LDMR	Low Density Multiple Reside	Single Family Res-Combo
95 105399 RK	PRD-LDMR	Low Density Multiple Reside	Single Family Res-Combo
95 101241 MH	CITY	City	MH Park-Double Wide
95 107131 RK	R-9,600	Residential 9,600 sq. ft.	Single Family Res-Combo
95 106864 RK	R-9,600	Residential 9,600 sq. ft.	Single Family Res-Combo
95 106865 RK	R-9,600	Residential 9,600 sq. ft.	SFR-Basic
95 104008 RK	PRD-7,200	Residential 7,200 sq. ft.	SFR-Basic
95 104012 RK	PRD-7,200	Residential 7,200 sq. ft.	SFR-Basic
94 140845 RK	PRD-7,200	Residential 7,200 sq. ft.	Single Family Res-Combo
95 105905 RK	R-5	Rural-5 Acre	Single Family Res-Combo

Accessory Dwelling Units

Index # - File Name: 1.0022 - Single Family Dwellings Data\_Snohomish County.pdf

95 107767 RK	PRD-9,600	Residential 9,600 sq. ft.	Single Family Res-Combo
95 109725 RK	PRD-9,600	Residential 9,600 sq. ft.	SFR-Basic
95 108304 RK	PRD-9,600	Residential 9,600 sq. ft.	Single Family Res-Combo
95 108556 RK	PRD-9,600	Residential 9,600 sq. ft.	SFR-Basic
95 107153 RK	PRD-9,600	Residential 9,600 sq. ft.	Single Family Res-Combo
95 107151 RK	PRD-9,600	Residential 9,600 sq. ft.	Single Family Res-Combo
95 108262 RK	PRD-9,600	Residential 9,600 sq. ft.	Single Family Res-Combo
95 108263 RK	PRD-9,600	Residential 9,600 sq. ft.	Single Family Res-Combo
95 108264 RK	PRD-9,600	Residential 9,600 sq. ft.	Single Family Res-Combo
95 107230 RK	R-5	Rural-5 Acre	Single Family Res-Combo
95 106600 RK	R-5	Rural-5 Acre	Single Family Res-Combo
95 104886 001 00 RK	R-5	Rural-5 Acre	Single Family Res-Combo
95 108074 RK	R-5	Rural-5 Acre	Single Family Res-Combo
95 105641 RK	R-8,400	Residential 8,400 sq. ft.	SFR-Basic
95 105642 RK	R-8,400	Residential 8,400 sq. ft.	SFR-Basic
95 105644 RK	R-8,400	Residential 8,400 sq. ft.	SFR-Basic
95 106057 RK	R-8,400	Residential 8,400 sq. ft.	Single Family Res-Combo
95 106059 RK	R-8,400	Residential 8,400 sq. ft.	Single Family Res-Combo
95 106568 RK	R-5	Rural-5 Acre	Single Family Res-Combo
95 106574 RK	R-5	Rural-5 Acre	Single Family Res-Combo
95 108747 RK	R-5	Rural-5 Acre	Single Family Res-Combo
95 106762 RK	R-7,200	Residential 7,200 sq. ft.	Single Family Res-Combo
95 105230 RK	R-5	Rural-5 Acre	Single Family Res-Combo
95 105305 RK	R-5	Rural-5 Acre	Single Family Res-Combo
95 105229 RK	R-5	Rural-5 Acre	Single Family Res-Combo
95 106915 RK	CITY	City	Single Family Res-Combo
95 106917 RK	CITY	City	Single Family Res-Combo
95 106918 RK	CITY	City	Single Family Res-Combo
95 106919 RK	CITY	City	Single Family Res-Combo
95 106165 RK	R-9,600	Residential 9,600 sq. ft.	Duplex-Combo
95 107833 RK	R-5	Rural-5 Acre	Single Family Res-Combo
95 100982 MH	CITY	City	MH Park-Double Wide
95 106727 RK	R-5	Rural-5 Acre	Single Family Res-Combo
95 107100 MH	CITY	City	MH Park-Double Wide
95 107172 RK	R-5	Rural-5 Acre	Single Family Res-Combo
95 107206 RK	R-5	Rural-5 Acre	Single Family Res-Combo
95 107463 RK	R-5	Rural-5 Acre	Single Family Res-Combo
95 107599 RK	R-7,200	Residential 7,200 sq. ft.	Single Family Res-Combo
95 107472 RK	R-7,200	Residential 7,200 sq. ft.	Single Family Res-Combo
95 107474 RK	R-7,200	Residential 7,200 sq. ft.	Single Family Res-Combo
95 107477 RK	R-7,200	Residential 7,200 sq. ft.	Single Family Res-Combo
95 108781 RK	R-7,200	Residential 7,200 sq. ft.	Single Family Res-Combo
95 108780 RK	R-7,200	Residential 7,200 sq. ft.	Single Family Res-Combo
95 108778 RK	R-7,200	Residential 7,200 sq. ft.	Single Family Res-Combo
95 107595 RK	R-7,200	Residential 7,200 sq. ft.	Single Family Res-Combo
95 109380 RK	R-7,200	Residential 7,200 sq. ft.	SFR-Basic
95 107734 RK	R-5	Rural-5 Acre	Single Family Res-Combo

Accessory Dwelling Units

Index # - File Name: 1.0022 - Single Family Dwellings Data\_Snohomish County.pdf

95 107706 RK	R-5	Rural-5 Acre	Single Family Res-Combo
95 108275 RK	RRT-10	Rural Resource Transition-10	Single Family Res-Combo
95 108273 RK	RRT-10	Rural Resource Transition-10	Single Family Res-Combo
95 108276 RK	RRT-10	Rural Resource Transition-10	Single Family Res-Combo
95 108277 RK	RRT-10	Rural Resource Transition-10	Single Family Res-Combo
95 107935 MH	CITY	City	MH Park-Double Wide
95 108072 RK	CITY	City	Duplex-Combo
95 108085 MH	R-5	Rural-5 Acre	Single Wide
95 108199 MH	MHP	Mobile Home Park	Single Wide
95 108936 RK	LDMR	Low Density Multiple Residence	Single Family Res-Combo
95 108334 MH	R-5	Rural-5 Acre	Single Wide
95 108469 RK	R-5	Rural-5 Acre	Single Family Res-Combo
95 108649 RK	A-10	Agriculture-10 Acre	Single Family Res-Combo
95 108650 RK	R-5	Rural-5 Acre	Single Family Res-Combo
95 108931 RK	CITY	City	Duplex-Combo
95 108679 RK	CITY	City	Single Family Res-Combo
95 108677 RK	CITY	City	Single Family Res-Combo
95 109375 MH	R-5	Rural-5 Acre	Double Wide
95 110186 RK	R-5	Rural-5 Acre	Single Family Res-Combo
95 110178 RK	R-5	Rural-5 Acre	Single Family Res-Combo
95 108728 RK	R-5	Rural-5 Acre	Single Family Res-Combo
95 108962 RK	R-5	Rural-5 Acre	Single Family Res-Combo
95 109166 RK	R-5	Rural-5 Acre	Single Family Res-Combo
95 110025 RK	R-5	Rural-5 Acre	Single Family Res-Combo
95 110021 RK	R-5	Rural-5 Acre	Single Family Res-Combo
95 110014 RK	R-5	Rural-5 Acre	Single Family Res-Combo
95 109936 RK	CITY	City	SFR-Basic
95 109934 RK	CITY	City	SFR-Basic
95 110018 RK	R-5	Rural-5 Acre	Single Family Res-Combo
95 101592 RK	R-5	Rural-5 Acre	Single Family Res-Combo
94 140789 RK	R-5	Rural-5 Acre	Single Family Res-Combo
94 140874 MH	R-5	Rural-5 Acre	Triple Wide
95 108455 MH	R-5	Rural-5 Acre	Double Wide
94 140287 RK	R-5	Rural-5 Acre	Single Family Res-Combo
95 100665 RK	R-5	Rural-5 Acre	Single Family Res-Combo
95 103199 RK	R-5	Rural-5 Acre	Single Family Res-Combo
94 140780 MH	R-5	Rural-5 Acre	Single Wide
95 106316 RK	R-5	Rural-5 Acre	Single Family Res-Combo
94 140342 RK	R-5	Rural-5 Acre	Single Family Res-Combo
94 140782 RK	R-5	Rural-5 Acre	Single Family Res-Combo
95 102096 RK	R-5	Rural-5 Acre	Single Family Res-Combo
95 103750 RK	R-5	Rural-5 Acre	Single Family Res-Combo
95 108229 MH	R-5	Rural-5 Acre	Double Wide
94 140360 RK	R-5	Rural-5 Acre	Single Family Res-Combo
95 108817 RK	R-5	Rural-5 Acre	Single Family Res-Combo
95 106184 MH	R-5	Rural-5 Acre	Single Wide
95 109172 RK	R-5	Rural-5 Acre	Single Family Res-Combo



Accessory Dwelling Units

Index # - File Name: 1.0022 - Single Family Dwellings Data\_Snohomish County.pdf

94 140192 MH	R-5	Rural-5 Acre	Single Wide
95 104126 MH	R-5	Rural-5 Acre	Double Wide
95 103312 MH	R-5	Rural-5 Acre	Double Wide
94 140195 RK	R-5	Rural-5 Acre	Single Family Res-Combo
95 103215 RK	R-5	Rural-5 Acre	Single Family Res-Combo
95 107007 RK	R-5	Rural-5 Acre	Single Family Res-Combo
95 110042 RK	R-5	Rural-5 Acre	Single Family Res-Combo
95 101014 RK	R-5	Rural-5 Acre	Single Family Res-Combo
95 103758 RK	R-5	Rural-5 Acre	Single Family Res-Combo
95 105292 RK	R-5	Rural-5 Acre	Single Family Res-Combo
95 109664 MH	R-5	Rural-5 Acre	Triple Wide
95 105761 RK	CITY	City	SFR-Basic
94 140915 MH	R-5	Rural-5 Acre	Double Wide
95 100707 RK	R-5	Rural-5 Acre	Single Family Res-Combo
95 105881 RK	R-5	Rural-5 Acre	Single Family Res-Combo
95 109654 MH	R-5	Rural-5 Acre	Double Wide
94 140814 RK	R-5	Rural-5 Acre	Single Family Res-Combo
95 108274 RK	R-5	Rural-5 Acre	Single Family Res-Combo
95 107027 MH	R-5	Rural-5 Acre	Double Wide
95 105033 RK	R-5	Rural-5 Acre	Single Family Res-Combo
94 241606 RK	R-5	Rural-5 Acre	Single Family Res-Combo
94 140553 MH	R-5	Rural-5 Acre	Triple Wide
95 109821 RK	R-5	Rural-5 Acre	Single Family Res-Combo
95 104632 RK	R-5	Rural-5 Acre	Accessory Apt Detached-Combo
95 108125 RK	RRT-10	Rural Resource Transition-1	Single Family Res-Combo
95 109601 MH	R-5	Rural-5 Acre	Double Wide
95 109464 RK	CITY	City	Single Family Res-Combo
95 103941 MH	RRT-10	Rural Resource Transition-1	Double Wide
93 125940 MH	RRT-10	Rural Resource Transition-1	Single Wide
95 101372 RK	CITY	City	Duplex-Combo
94 140894 RK	R-5	Rural-5 Acre	Single Family Res-Combo
95 100720 MH	R-5	Rural-5 Acre	Single Wide
95 107984 RK	R-5	Rural-5 Acre	Single Family Res-Combo
95 101902 RK	PRD-9,600	Residential 9,600 sq. ft.	Single Family Res-Combo
95 106339 RK	PRD-9,600	Residential 9,600 sq. ft.	Single Family Res-Combo
95 100614 RK	R-5	Rural-5 Acre	Single Family Res-Combo
95 103083 RK	R-5	Rural-5 Acre	Single Family Res-Combo
95 108407 RK	R-5	Rural-5 Acre	Single Family Res-Combo
95 106169 RK	R-5	Rural-5 Acre	Single Family Res-Combo
95 101298 MH	R-5	Rural-5 Acre	Double Wide
95 107680 RK	PRD-9,600	Residential 9,600 sq. ft.	Single Family Res-Combo
95 105665 RK	PRD-9,600	Residential 9,600 sq. ft.	Single Family Res-Combo
95 102351 RK	RRT-10	Rural Resource Transition-1	Single Family Res-Combo
95 104360 RK	R-5	Rural-5 Acre	Single Family Res-Combo
95 108701 RK	RRT-10	Rural Resource Transition-1	Single Family Res-Combo
95 105693 MH	RRT-10	Rural Resource Transition-1	Single Wide
95 106588 RK	R-5	Rural-5 Acre	Single Family Res-Combo

Accessory Dwelling Units

Index # - File Name: 1.0022 - Single Family Dwellings Data\_Snohomish County.pdf

94 240299 RK	R-5	Rural-5 Acre	SFR-Basic
95 106611 RK	R-5	Rural-5 Acre	Single Family Res-Combo
95 109555 RK	CITY	City	Single Family Res-Combo
95 105784 RK	CITY	City	Single Family Res-Combo
94 140240 MH	R-5	Rural-5 Acre	Single Wide
95 102911 MH	R-5	Rural-5 Acre	Single Wide
94 140111 MH	R-5	Rural-5 Acre	Double Wide
95 108731 RK	CITY	City	Single Family Res-Combo
95 106937 RK	R-5	Rural-5 Acre	Single Family Res-Combo
95 106936 RK	R-5	Rural-5 Acre	Single Family Res-Combo
95 108300 RK	R-5	Rural-5 Acre	Single Family Res-Combo
95 107182 MH	R-5	Rural-5 Acre	Double Wide
95 106824 RK	CITY	City	Single Family Res-Combo
95 104001 RK	R-5	Rural-5 Acre	Single Family Res-Combo
95 104745 RK	R-5	Rural-5 Acre	Single Family Res-Combo
95 107924 RK	R-5	Rural-5 Acre	Single Family Res-Combo
95 103811 MH	R-5	Rural-5 Acre	Double Wide
94 140853 RK	R-5	Rural-5 Acre	Single Family Res-Combo
94 140150 MH	R-5	Rural-5 Acre	Double Wide
94 140139 MH	R-5	Rural-5 Acre	Double Wide
95 108096 RK	R-5	Rural-5 Acre	Single Family Res-Combo
95 107996 MH	R-5	Rural-5 Acre	Single Wide
94 140204 MH	R-5	Rural-5 Acre	Double Wide
95 101780 RK	R-5	Rural-5 Acre	Single Family Res-Combo
95 101382 RK	R-5	Rural-5 Acre	Single Family Res-Combo
92 130619 000 01 RK	R-5	Rural-5 Acre	Single Family Res-Combo
95 105156 RK	R-5	Rural-5 Acre	Accessory Apt Detached-Combo
95 102396 RK	CITY	City	Single Family Res-Combo
95 102492 RK	CITY	City	Single Family Res-Combo
95 105953 RK	CITY	City	SFR-Basic
95 102634 RK	R-5	Rural-5 Acre	Single Family Res-Combo
95 102632 RK	R-5	Rural-5 Acre	Single Family Res-Combo
95 109393 RK	R-9,600	Residential 9,600 sq. ft.	Single Family Res-Combo
94 321526 RK	R-9,600	Residential 9,600 sq. ft.	Single Family Res-Combo
95 104280 MH	CITY	City	Double Wide
95 101555 RK	CITY	City	Single Family Res-Combo
92 135329 000 01 RK	R-9,600	Residential 9,600 sq. ft.	Single Family Res-Combo
95 106073 RK	CITY	City	Single Family Res-Combo
95 101344 RK	F	Forestry	Single Family Res-Combo
95 103889 RK	R-5	Rural-5 Acre	Single Family Res-Combo
95 108618 RK	R-5	Rural-5 Acre	Single Family Res-Combo
95 104229 RK	R-5	Rural-5 Acre	Single Family Res-Combo
95 106110 RK	R-5	Rural-5 Acre	Single Family Res-Combo
94 140457 RK	R-5	Rural-5 Acre	Single Family Res-Combo
95 103146 MH	R-5	Rural-5 Acre	Double Wide
95 103757 MH	R-5	Rural-5 Acre	Triple Wide
95 100823 MH	R-5	Rural-5 Acre	Double Wide

Accessory Dwelling Units

Index # - File Name: 1.0022 - Single Family Dwellings Data\_Snohomish County.pdf

94 140247 MH	F	Forestry	Single Wide
92 140018 RK	CITY	City	Duplex-Combo
94 140171 RK	F	Forestry	Single Family Res-Combo
95 107757 RK	R-5	Rural-5 Acre	Single Family Res-Combo
95 102994 RK	R-9,600	Residential 9,600 sq. ft.	Single Family Res-Combo
94 240312 RK	R-5	Rural-5 Acre	Single Family Res-Combo
95 108709 MH	RC	Rural Conservation	Double Wide
94 241531 MH	R-5	Rural-5 Acre	Double Wide
95 105830 RK	CITY : R-9,600	City : Residential 9,600 sq. ft	Single Family Res-Combo
95 108463 RK	CITY : R-9,600	City : Residential 9,600 sq. ft	Single Family Res-Combo
94 140797 RK	R-5	Rural-5 Acre	Single Family Res-Combo
95 108772 MH	R-5	Rural-5 Acre	Single Wide
94 140433 MH	R-5	Rural-5 Acre	Double Wide
95 107999 RK	R-5	Rural-5 Acre	Single Family Res-Combo
95 100648 RK	R-5	Rural-5 Acre	Single Family Res-Combo
94 140181 MH	R-12,500	Residential 12,500 sq. ft.	Double Wide
95 109676 RK	R-5	Rural-5 Acre	Single Family Res-Combo
95 103916 RK	R-8,400	Residential 8,400 sq. ft.	Single Family Res-Combo
95 108733 MH	R-12,500	Residential 12,500 sq. ft.	Double Wide
95 106874 RK	F	Forestry	Single Family Res-Combo
95 104626 RK	R-5	Rural-5 Acre	SFR-Basic
94 140401 RK	R-5	Rural-5 Acre	Single Family Res-Combo
95 108749 MH	R-5	Rural-5 Acre	Double Wide
94 140355 MH	R-5	Rural-5 Acre	Double Wide
95 105216 RK	F	Forestry	Single Family Res-Combo
95 110185 RK	R-9,600	Residential 9,600 sq. ft.	Single Family Res-Combo
95 103438 RK	F	Forestry	SFR-Basic
95 110427 MH	F	Forestry	Double Wide
94 140389 RK	F	Forestry	Single Family Res-Combo
94 140325 RK	F	Forestry	Single Family Res-Combo
95 101629 MH	F	Forestry	Single Wide
95 109118 RK	F	Forestry	Single Family Res-Combo
95 108492 MH	R-5	Rural-5 Acre	Double Wide
95 108977 RK	R-5	Rural-5 Acre	Single Family Res-Combo
95 107461 RK	R-5	Rural-5 Acre	Single Family Res-Combo
95 107464 RK	R-5	Rural-5 Acre	Single Family Res-Combo
94 140559 RK	R-5	Rural-5 Acre	Single Family Res-Combo
95 108744 RK	R-5	Rural-5 Acre	Single Family Res-Combo
95 108131 RK	R-5	Rural-5 Acre	Single Family Res-Combo
95 108177 MH	R-5	Rural-5 Acre	Triple Wide
95 101226 RK	R-5	Rural-5 Acre	Single Family Res-Combo
94 140638 RK	R-5	Rural-5 Acre	Single Family Res-Combo
95 110054 MH	F	Forestry	Double Wide
94 140703 MH	R-5	Rural-5 Acre	Triple Wide
95 105666 RK	F	Forestry	Single Family Res-Combo
95 106320 RK	F	Forestry	Single Family Res-Combo
95 103632 MH	R-5	Rural-5 Acre	Triple Wide

Accessory Dwelling Units

Index # - File Name: 1.0022 - Single Family Dwellings Data\_Snohomish County.pdf

95 106550 RK	R-5	Rural-5 Acre	Accessory Apt Detached-Combo
95 107283 RK	R-9,600	Residential 9,600 sq. ft.	Single Family Res-Combo
95 100167 RK	R-9,600	Residential 9,600 sq. ft.	Single Family Res-Combo
95 102373 RK	MR	Multiple Residential	Single Family Res-Combo
92 125927 RK	A-10 : F	Agriculture-10 Acre : Forestr	Single Family Res-Combo
94 140422 RK	R-8,400	Residential 8,400 sq. ft.	Single Family Res-Combo
95 102810 RK	F	Forestry	Single Family Res-Combo
94 140234 RK	F	Forestry	Single Family Res-Combo
95 110122 MH	R-5	Rural-5 Acre	Double Wide
95 104446 RK	F	Forestry	Single Family Res-Combo
95 105128 RK	R-5	Rural-5 Acre	Accessory Apt Detached-Combo
95 105134 MH	MHP	Mobile Home Park	MH Park-Single Wide
95 107470 MH	R-5	Rural-5 Acre	Double Wide
96 100916 MH	PRD-20,000(M	Residential 20,000 sq. ft. : R	Double Wide
96 103985 MH	R-5	Rural-5 Acre	Single Wide
96 109529 MH	CITY	City	MH Park-Double Wide
95 108108 RK	R-5	Rural-5 Acre	Single Family Res-Combo
96 107787 RK	R-5	Rural-5 Acre	Single Family Res-Combo
96 106433 MH	F	Forestry	Double Wide
95 109592 RK	R-5	Rural-5 Acre	Single Family Res-Combo
96 100319 MH	R-5	Rural-5 Acre	Double Wide
95 110041 RK	R-5	Rural-5 Acre	Single Family Res-Combo
96 103735 RK	R-5	Rural-5 Acre	Single Family Res-Combo
96 101254 RK	A-10	Agriculture-10 Acre	Single Family Res-Combo
96 106444 RK	A-10	Agriculture-10 Acre	Single Family Res-Combo
95 109819 RK	R-5	Rural-5 Acre	Single Family Res-Combo
95 105191 RK	F	Forestry	Single Family Res-Combo
96 108629 RK	R-5	Rural-5 Acre	Single Family Res-Combo
96 103446 RK	R-5	Rural-5 Acre	Single Family Res-Combo
96 109033 RK	F	Forestry	Single Family Res-Combo
96 100651 RK	F	Forestry	Single Family Res-Combo
96 103665 MH	R-5	Rural-5 Acre	Double Wide
96 105615 RK	R-5	Rural-5 Acre	Single Family Res-Combo
94 140191 MH	R-5	Rural-5 Acre	Double Wide
95 109123 RK	A-10	Agriculture-10 Acre	Single Family Res-Combo
95 106294 RK	R-5	Rural-5 Acre	Single Family Res-Combo
96 102174 RK	R-5	Rural-5 Acre	Single Family Res-Combo
96 101067 RK	R-5	Rural-5 Acre	Duplex-Combo
96 103816 RK	R-9,600	Residential 9,600 sq. ft.	Single Family Res-Combo
96 106380 RK	MR	Multiple Residential	Single Family Res-Combo
96 106382 RK	MR	Multiple Residential	Single Family Res-Combo
96 110064 RK	R-9,600	Residential 9,600 sq. ft.	Single Family Res-Combo
96 101474 RK	R-9,600	Residential 9,600 sq. ft.	Single Family Res-Combo
96 108791 RK	MR	Multiple Residential	Single Family Res-Combo
96 107761 RK	R-5	Rural-5 Acre	Single Family Res-Combo
96 107301 RK	R-5	Rural-5 Acre	Single Family Res-Combo
96 102041 MH	R-5	Rural-5 Acre	Single Wide

Accessory Dwelling Units

Index # - File Name: 1.0022 - Single Family Dwellings Data\_Snohomish County.pdf

96 107101 MH	R-5	Rural-5 Acre	Double Wide
96 109953 RK	R-5	Rural-5 Acre	Single Family Res-Combo
96 104187 RK	R-5	Rural-5 Acre	Single Family Res-Combo
96 108399 RK	R-5	Rural-5 Acre	Single Family Res-Combo
96 100161 RK	R-5	Rural-5 Acre	Single Family Res-Combo
96 102772 RK	R-5	Rural-5 Acre	Single Family Res-Combo
96 102762 RK	A-10 : R-5	Agriculture-10 Acre : Rural-5	Single Family Res-Combo
96 106833 RK	R-5	Rural-5 Acre	Single Family Res-Combo
96 100739 RK	R-5	Rural-5 Acre	Single Family Res-Combo
96 109897 RK	R-5	Rural-5 Acre	Single Family Res-Combo
95 108386 MH	MR	Multiple Residential	Double Wide
96 101045 RK	MR	Multiple Residential	Single Family Res-Combo
96 102753 RK	R-5	Rural-5 Acre	Single Family Res-Combo
96 105212 RK	R-5	Rural-5 Acre	Single Family Res-Combo
96 108627 RK	R-5	Rural-5 Acre	SFR-Basic
96 108623 RK	R-5	Rural-5 Acre	Single Family Res-Combo
96 105790 RK	R-5	Rural-5 Acre	Duplex-Combo
92 140503 RK	A-10	Agriculture-10 Acre	Single Family Res-Combo
96 106000 RK	R-5	Rural-5 Acre	Single Family Res-Combo
96 101293 RK	R-5	Rural-5 Acre	Single Family Res-Combo
95 108827 RK	R-5	Rural-5 Acre	Single Family Res-Combo
96 108309 MH	A-10	Agriculture-10 Acre	Double Wide
96 105900 RK	R-8,400	Residential 8,400 sq. ft.	SFR-Basic
96 106584 RK	R-5	Rural-5 Acre	SFR-Basic
96 102872 RK	R-5	Rural-5 Acre	Single Family Res-Combo
96 106015 RK	R-5	Rural-5 Acre	Single Family Res-Combo
94 140325 000 01 RK	F	Forestry	Single Family Res-Combo
96 110513 MH	F	Forestry	Double Wide
96 103900 MH	F	Forestry	Double Wide
96 102887 MH	R-5	Rural-5 Acre	Double Wide
96 104644 RK	A-10	Agriculture-10 Acre	Single Family Res-Combo
96 108790 RK	R-9,600	Residential 9,600 sq. ft.	Single Family Res-Combo
96 100020 MH	R-5	Rural-5 Acre	Single Wide
94 140668 MH	A-10	Agriculture-10 Acre	Double Wide
96 103545 RK	R-7,200	Residential 7,200 sq. ft.	Single Family Res-Combo
96 110058 RK	R-9,600	Residential 9,600 sq. ft.	Single Family Res-Combo
96 107087 RK	CITY	City	Single Family Res-Combo
95 110834 RK	R-8,400	Residential 8,400 sq. ft.	Single Family Res-Combo
95 107072 RK	F	Forestry	Single Family Res-Combo
96 108165 RK	R-12,500	Residential 12,500 sq. ft.	Single Family Res-Combo
96 104840 RK	R-12,500	Residential 12,500 sq. ft.	Single Family Res-Combo
96 107454 MH	LDMR	Low Density Multiple Reside	Double Wide
96 105859 MH	CITY	City	Double Wide
96 103334 RK	R-5	Rural-5 Acre	Single Family Res-Combo
96 100865 MH	R-5	Rural-5 Acre	Double Wide
96 107171 RK	R-5	Rural-5 Acre	Single Family Res-Combo
96 105138 RK	R-5	Rural-5 Acre	Single Family Res-Combo

Accessory Dwelling Units

Index # - File Name: 1.0022 - Single Family Dwellings Data\_Snohomish County.pdf

96 104209 RK	MR	Multiple Residential	Duplex-Combo
95 107923 RK	R-5	Rural-5 Acre	Single Family Res-Combo
96 109052 RK	MR	Multiple Residential	Single Family Res-Combo
96 101247 RK	R-5	Rural-5 Acre	Single Family Res-Combo
96 107294 RK	R-5	Rural-5 Acre	Single Family Res-Combo
96 101397 RK	F	Forestry	Single Family Res-Combo
96 106374 RK	R-5	Rural-5 Acre	Single Family Res-Combo
96 103456 RK	R-5	Rural-5 Acre	Single Family Res-Combo
96 104052 MH	F	Forestry	Single Wide
96 100486 RK	R-5	Rural-5 Acre	Single Family Res-Combo
96 101376 RK	R-5	Rural-5 Acre	Single Family Res-Combo
96 100657 RK	F	Forestry	Single Family Res-Combo
96 103056 RK	R-5	Rural-5 Acre	Single Family Res-Combo
95 110365 MH	R-5	Rural-5 Acre	Single Wide
95 109639 MH	F	Forestry	Double Wide
96 102238 MH	F	Forestry	Double Wide
96 108058 RK	R-5	Rural-5 Acre	Single Family Res-Combo
96 108688 RK	R-5	Rural-5 Acre	Single Family Res-Combo
96 103309 RK	PRD-9,600	Residential 9,600 sq. ft.	Single Family Res-Combo
96 104955 RK	R-5	Rural-5 Acre	Single Family Res-Combo
96 102190 RK	R-5	Rural-5 Acre	Single Family Res-Combo
95 110905 RK	R-5	Rural-5 Acre	Single Family Res-Combo
96 102767 RK	R-5	Rural-5 Acre	Single Family Res-Combo
96 102172 RK	R-5	Rural-5 Acre	Single Family Res-Combo
96 109137 MH	R-7,200	Residential 7,200 sq. ft.	Double Wide
96 101103 RK	F	Forestry	Single Family Res-Combo
96 104585 RK	R-5	Rural-5 Acre	Single Family Res-Combo
96 103065 RK	LDMR	Low Density Multiple Reside	Single Family Res-Combo
96 107371 MH	CITY	City	Double Wide
96 109596 MH	R-7,200	Residential 7,200 sq. ft.	Double Wide
96 100828 RK	R-5	Rural-5 Acre	Single Family Res-Combo
96 101872 RK	R-9,600	Residential 9,600 sq. ft.	Single Family Res-Combo
96 101873 RK	R-9,600	Residential 9,600 sq. ft.	Single Family Res-Combo
96 101870 RK	R-9,600	Residential 9,600 sq. ft.	Single Family Res-Combo
96 100049 MH	R-7,200	Residential 7,200 sq. ft.	Double Wide
96 102769 RK	R-5	Rural-5 Acre	Single Family Res-Combo
96 100426 RK	R-9,600	Residential 9,600 sq. ft.	SFR-Basic
96 106701 RK	R-9,600	Residential 9,600 sq. ft.	SFR-Basic
96 105342 RK	R-9,600	Residential 9,600 sq. ft.	Single Family Res-Combo
96 100433 RK	R-9,600	Residential 9,600 sq. ft.	Single Family Res-Combo
96 106207 RK	R-5	Rural-5 Acre	Single Family Res-Combo
96 103103 RK	R-9,600	Residential 9,600 sq. ft.	SFR-Basic
96 106699 RK	R-9,600	Residential 9,600 sq. ft.	SFR-Basic
96 102551 RK	R-5	Rural-5 Acre	Single Family Res-Combo
96 106115 RK	R-5	Rural-5 Acre	Single Family Res-Combo
96 100897 RK	R-5	Rural-5 Acre	Single Family Res-Combo
96 109267 RK	R-5	Rural-5 Acre	Single Family Res-Combo

Accessory Dwelling Units

Index # - File Name: 1.0022 - Single Family Dwellings Data\_Snohomish County.pdf

96 104485 RK	R-5	Rural-5 Acre	Single Family Res-Combo
95 109830 RK	R-5	Rural-5 Acre	Single Family Res-Combo
96 107258 RK	R-5	Rural-5 Acre	Single Family Res-Combo
96 106718 RK	R-5	Rural-5 Acre	Single Family Res-Combo
96 107081 RK	R-5	Rural-5 Acre	Accessory Apt Detached-Combo
95 110934 MH	R-5	Rural-5 Acre	Double Wide
96 101197 RK	R-5	Rural-5 Acre	Single Family Res-Combo
96 106650 MH	R-5	Rural-5 Acre	Triple Wide
96 106618 MH	R-5	Rural-5 Acre	Double Wide
96 105627 MH	CITY	City	Double Wide
96 103449 RK	R-9,600	Residential 9,600 sq. ft.	Single Family Res-Combo
96 110448 MH	R-7,200	Residential 7,200 sq. ft.	Double Wide
96 109516 RK	R-7,200	Residential 7,200 sq. ft.	Accessory Apt Detached-Combo
96 105425 RK	R-5	Rural-5 Acre	Single Family Res-Combo
96 105460 RK	R-9,600	Residential 9,600 sq. ft.	Duplex-Combo
95 109826 RK	R-5	Rural-5 Acre	Single Family Res-Combo
96 105080 RK	R-5	Rural-5 Acre	Single Family Res-Combo
96 104111 RK	R-5	Rural-5 Acre	Single Family Res-Combo
96 101126 RK	R-5	Rural-5 Acre	Single Family Res-Combo
95 109365 MH	R-5	Rural-5 Acre	Double Wide
96 103188 RK	R-5	Rural-5 Acre	Single Family Res-Combo
96 105395 RK	R-5	Rural-5 Acre	Single Family Res-Combo
95 110749 RK	R-5	Rural-5 Acre	Single Family Res-Combo
95 110840 RK	R-5	Rural-5 Acre	Single Family Res-Combo
96 100046 RK	R-5	Rural-5 Acre	Single Family Res-Combo
96 104287 RK	R-5	Rural-5 Acre	Single Family Res-Combo
95 109663 RK	R-5	Rural-5 Acre	Single Family Res-Combo
96 104356 RK	R-5	Rural-5 Acre	Single Family Res-Combo
96 100323 RK	R-5	Rural-5 Acre	Single Family Res-Combo
96 102169 MH	R-5	Rural-5 Acre	Double Wide
96 103704 MH	RRT-10	Rural Resource Transition-10	Double Wide
96 105959 MH	RRT-10	Rural Resource Transition-10	Double Wide
96 101640 RK	R-5	Rural-5 Acre	Single Family Res-Combo
96 106113 MH	R-5	Rural-5 Acre	Double Wide
96 106837 RK	R-5	Rural-5 Acre	Single Family Res-Combo
96 108479 RK	RRT-10	Rural Resource Transition-10	Single Family Res-Combo
96 100162 RK	R-5	Rural-5 Acre	Single Family Res-Combo
96 104422 MH	R-5	Rural-5 Acre	Triple Wide
96 101097 RK	R-5	Rural-5 Acre	Single Family Res-Combo
96 109812 MH	R-5	Rural-5 Acre	Double Wide
95 108976 RK	R-5	Rural-5 Acre	Single Family Res-Combo
96 109158 RK	CITY	City	Single Family Res-Combo
95 105750 RK	CITY	City	Single Family Res-Combo
96 107140 RK	CITY	City	Single Family Res-Combo
96 107928 RK	CITY	City	Single Family Res-Combo
96 110048 MH	R-5	Rural-5 Acre	Triple Wide
96 103697 MH	CITY	City	Double Wide

Accessory Dwelling Units

Index # - File Name: 1.0022 - Single Family Dwellings Data\_Snohomish County.pdf

96 106108 RK	R-5	Rural-5 Acre	Single Family Res-Combo
96 108630 MH	SA-1	Suburban Agriculture-1 Acre	Double Wide
96 106794 RK	PRD-9,600	Residential 9,600 sq. ft.	Single Family Res-Combo
96 109192 RK	PRD-9,600	Residential 9,600 sq. ft.	SFR-Basic
95 109656 RK	R-5	Rural-5 Acre	Single Family Res-Combo
95 109667 RK	R-5	Rural-5 Acre	Single Family Res-Combo
96 108683 RK	R-5	Rural-5 Acre	Single Family Res-Combo
95 109668 RK	R-5	Rural-5 Acre	Single Family Res-Combo
95 109670 RK	R-5	Rural-5 Acre	Single Family Res-Combo
95 108501 MH	SA-1	Suburban Agriculture-1 Acre	Double Wide
96 102078 MH	SA-1	Suburban Agriculture-1 Acre	Double Wide
95 110898 RK	PRD-9,600	Residential 9,600 sq. ft.	Single Family Res-Combo
96 100771 RK	PRD-9,600	Residential 9,600 sq. ft.	Single Family Res-Combo
96 106260 RK	RRT-10	Rural Resource Transition-10	Single Family Res-Combo
96 106708 RK	CITY	City	Single Family Res-Combo
96 102542 RK	CITY	City	Single Family Res-Combo
96 101894 RK	R-5	Rural-5 Acre	Single Family Res-Combo
96 108622 MH	RRT-10	Rural Resource Transition-10	Triple Wide
96 108601 RK	RRT-10	Rural Resource Transition-10	Single Family Res-Combo
95 108761 MH	R-5	Rural-5 Acre	Double Wide
96 108682 RK	R-5	Rural-5 Acre	Single Family Res-Combo
96 108276 RK	R-5	Rural-5 Acre	Single Family Res-Combo
96 108279 RK	R-5	Rural-5 Acre	Single Family Res-Combo
96 108681 RK	R-5	Rural-5 Acre	SFR-Basic
96 108678 RK	R-5	Rural-5 Acre	SFR-Basic
96 105714 RK	R-5	Rural-5 Acre	Single Family Res-Combo
96 100653 MH	R-5	Rural-5 Acre	Double Wide
96 105435 MH	R-5	Rural-5 Acre	Single Wide
96 103872 MH	R-5	Rural-5 Acre	Double Wide
96 107467 MH	R-5	Rural-5 Acre	Double Wide
96 106169 RK	RRT-10	Rural Resource Transition-10	Single Family Res-Combo
96 108354 MH	R-5	Rural-5 Acre	Double Wide
96 107362 RK	RRT-10	Rural Resource Transition-10	Single Family Res-Combo
96 100652 MH	SA-1	Suburban Agriculture-1 Acre	Double Wide
96 105784 RK	SA-1	Suburban Agriculture-1 Acre	Single Family Res-Combo
96 105394 RK	CITY	City	Single Family Res-Combo
95 107747 RK	SA-1	Suburban Agriculture-1 Acre	Single Family Res-Combo
96 102469 RK	CITY	City	Single Family Res-Combo
96 103003 MH	R-5	Rural-5 Acre	Double Wide
96 108886 RK	R-5	Rural-5 Acre	Single Family Res-Combo
96 103369 RK	SA-1	Suburban Agriculture-1 Acre	Single Family Res-Combo
96 105436 MH	R-5	Rural-5 Acre	Double Wide
95 106781 MH	R-5	Rural-5 Acre	Double Wide
96 104041 MH	R-5	Rural-5 Acre	Double Wide
96 102220 RK	R-5	Rural-5 Acre	Single Family Res-Combo
96 105930 MH	R-5	Rural-5 Acre	Single Wide
96 103609 MH	R-5	Rural-5 Acre	Single Wide



Accessory Dwelling Units

Index # - File Name: 1.0022 - Single Family Dwellings Data\_Snohomish County.pdf

96 102274 RK	R-5	Rural-5 Acre	Single Family Res-Combo
96 105552 RK	R-5	Rural-5 Acre	Single Family Res-Combo
96 107338 RK	R-5	Rural-5 Acre	Single Family Res-Combo
96 100855 RK	R-5	Rural-5 Acre	Single Family Res-Combo
96 102959 MH	R-5	Rural-5 Acre	Double Wide
96 106834 RK	R-5	Rural-5 Acre	Single Family Res-Combo
96 106623 MH	R-5	Rural-5 Acre	Double Wide
96 109858 RK	R-5	Rural-5 Acre	Single Family Res-Combo
96 108972 RK	R-5	Rural-5 Acre	Single Family Res-Combo
96 103127 RK	R-5	Rural-5 Acre	Single Family Res-Combo
96 103883 MH	R-5	Rural-5 Acre	Double Wide
96 106712 MH	CITY	City	Triple Wide
96 103613 RK	R-5	Rural-5 Acre	Single Family Res-Combo
96 106438 MH	R-5	Rural-5 Acre	Double Wide
96 106707 RK	R-5	Rural-5 Acre	Single Family Res-Combo
96 100678 RK	R-5	Rural-5 Acre	Single Family Res-Combo
96 101514 RK	R-5	Rural-5 Acre	Single Family Res-Combo
95 108003 RK	R-5	Rural-5 Acre	Single Family Res-Combo
96 107893 MH	R-5	Rural-5 Acre	Double Wide
96 100455 MH	A-10 : R-5	Agriculture-10 Acre : Rural-5	Double Wide
96 100863 RK	R-5	Rural-5 Acre	Single Family Res-Combo
96 101348 RK	R-5	Rural-5 Acre	Single Family Res-Combo
96 106299 RK	R-5	Rural-5 Acre	Single Family Res-Combo
96 106303 MH	R-5	Rural-5 Acre	Single Wide
96 106229 RK	R-5	Rural-5 Acre	Single Family Res-Combo
96 109179 MH	R-5	Rural-5 Acre	Double Wide
96 101889 MH	R-5	Rural-5 Acre	Triple Wide
95 110595 RK	R-5	Rural-5 Acre	Single Family Res-Combo
96 106755 MH	R-5	Rural-5 Acre	Triple Wide
96 104206 RK	R-5	Rural-5 Acre	Single Family Res-Combo
96 107701 RK	R-5	Rural-5 Acre	Single Family Res-Combo
96 106982 RK	R-5	Rural-5 Acre	Single Family Res-Combo
96 105096 MH	R-5	Rural-5 Acre	Double Wide
96 105020 RK	R-5	Rural-5 Acre	Single Family Res-Combo
96 107064 RK	R-5	Rural-5 Acre	SFR-Basic
96 107320 MH	R-5	Rural-5 Acre	Triple Wide
96 109929 RK	R-7,200	Residential 7,200 sq. ft.	Single Family Res-Combo
96 104691 RK	R-5	Rural-5 Acre	Single Family Res-Combo
96 108064 RK	R-5	Rural-5 Acre	Single Family Res-Combo
96 110004 RK	R-5	Rural-5 Acre	Single Family Res-Combo
94 140226 RK	R-5	Rural-5 Acre	Single Family Res-Combo
95 110063 RK	R-5	Rural-5 Acre	Single Family Res-Combo
96 105440 RK	R-5	Rural-5 Acre	Single Family Res-Combo
96 104129 RK	R-5	Rural-5 Acre	Single Family Res-Combo
96 106813 RK	R-5	Rural-5 Acre	Single Family Res-Combo
96 105826 RK	R-5	Rural-5 Acre	SFR-Basic
96 101404 RK	R-5	Rural-5 Acre	Single Family Res-Combo

Accessory Dwelling Units

Index # - File Name: 1.0022 - Single Family Dwellings Data\_Snohomish County.pdf

93 140062 MH	R-5	Rural-5 Acre	Single Wide
96 103362 RK	R-5	Rural-5 Acre	Single Family Res-Combo
95 110562 RK	R-5	Rural-5 Acre	Single Family Res-Combo
96 103149 RK	R-5	Rural-5 Acre	Single Family Res-Combo
96 105743 RK	R-5	Rural-5 Acre	Single Family Res-Combo
96 105164 MH	R-5	Rural-5 Acre	Triple Wide
96 102605 RK	R-5	Rural-5 Acre	Single Family Res-Combo
96 106559 RK	R-5	Rural-5 Acre	Single Family Res-Combo
96 108836 MH	A-10	Agriculture-10 Acre	Single Wide
96 105940 RK	R-5	Rural-5 Acre	Single Family Res-Combo
96 101909 RK	R-5	Rural-5 Acre	Single Family Res-Combo
96 101813 MH	R-5	Rural-5 Acre	Double Wide
96 105202 RK	R-5	Rural-5 Acre	Single Family Res-Combo
96 102756 RK	R-5	Rural-5 Acre	Single Family Res-Combo
96 106192 MH	R-5	Rural-5 Acre	Double Wide
96 101052 MH	R-5	Rural-5 Acre	Double Wide
96 109077 MH	R-5	Rural-5 Acre	Double Wide
96 105270 RK	R-5	Rural-5 Acre	Single Family Res-Combo
96 107293 RK	R-5	Rural-5 Acre	Single Family Res-Combo
96 103602 MH	R-5	Rural-5 Acre	Single Wide
96 102652 RK	R-5	Rural-5 Acre	Single Family Res-Combo
96 100918 MH	R-5	Rural-5 Acre	Triple Wide
96 107270 MH	RD	Rural Diversification	Double Wide
96 103316 RK	R-5	Rural-5 Acre	Single Family Res-Combo
95 107003 MH	R-5	Rural-5 Acre	Double Wide
96 104905 RK	RD	Rural Diversification	Single Family Res-Combo
96 103292 MH	RD	Rural Diversification	Double Wide
96 108705 MH	R-5	Rural-5 Acre	Double Wide
96 104880 RK	R-5	Rural-5 Acre	Single Family Res-Combo
96 107106 RK	R-5	Rural-5 Acre	Single Family Res-Combo
96 100462 RK	R-5	Rural-5 Acre	Single Family Res-Combo
96 103541 RK	RC	Rural Conservation	Single Family Res-Combo
96 104316 RK	R-5	Rural-5 Acre	SFR-Basic
96 101075 MH	R-5	Rural-5 Acre	Double Wide
96 102491 MH	R-5	Rural-5 Acre	Double Wide
96 105268 RK	R-5	Rural-5 Acre	Single Family Res-Combo
96 104832 MH	R-5	Rural-5 Acre	Double Wide
96 105439 RK	R-5	Rural-5 Acre	Single Family Res-Combo
96 101205 RK	R-5	Rural-5 Acre	Single Family Res-Combo
96 105593 RK	R-5	Rural-5 Acre	Single Family Res-Combo
95 109859 MH	R-5	Rural-5 Acre	Single Wide
95 110319 RK	CITY	City	Single Family Res-Combo
96 100799 RK	R-5	Rural-5 Acre	Single Family Res-Combo
96 100803 RK	R-5	Rural-5 Acre	Single Family Res-Combo
96 103466 RK	R-5	Rural-5 Acre	SFR-Basic
96 104559 RK	R-5	Rural-5 Acre	SFR-Basic
96 110442 RK	R-5	Rural-5 Acre	Single Family Res-Combo

Accessory Dwelling Units

Index # - File Name: 1.0022 - Single Family Dwellings Data\_Snohomish County.pdf

96 107065 RK	R-5	Rural-5 Acre	Single Family Res-Combo
96 104663 RK	PRD-9,600	Residential 9,600 sq. ft.	SFR-Basic
96 104665 RK	PRD-9,600	Residential 9,600 sq. ft.	SFR-Basic
96 104666 RK	PRD-9,600	Residential 9,600 sq. ft.	SFR-Basic
96 109355 RK	R-5	Rural-5 Acre	Single Family Res-Combo
96 102822 RK	R-5	Rural-5 Acre	Single Family Res-Combo
96 102819 RK	R-5	Rural-5 Acre	Single Family Res-Combo
96 102821 RK	R-5	Rural-5 Acre	Single Family Res-Combo
96 102426 RK	R-5	Rural-5 Acre	Single Family Res-Combo
96 109347 RK	R-5	Rural-5 Acre	Single Family Res-Combo
96 109349 RK	R-5	Rural-5 Acre	Single Family Res-Combo
96 107063 RK	R-5	Rural-5 Acre	SFR-Basic
96 104980 RK	R-5	Rural-5 Acre	SFR-Basic
96 104981 RK	R-5	Rural-5 Acre	SFR-Basic
95 110733 RK	PRD-9,600	Residential 9,600 sq. ft.	Single Family Res-Combo
96 103196 RK	PRD-9,600	Residential 9,600 sq. ft.	SFR-Basic
96 103195 RK	PRD-9,600	Residential 9,600 sq. ft.	SFR-Basic
96 103199 RK	PRD-9,600	Residential 9,600 sq. ft.	SFR-Basic
96 103509 RK	PRD-9,600	Residential 9,600 sq. ft.	SFR-Basic
96 103506 RK	PRD-9,600	Residential 9,600 sq. ft.	SFR-Basic
96 103507 RK	PRD-9,600	Residential 9,600 sq. ft.	SFR-Basic
96 108087 RK	PRD-9,600	Residential 9,600 sq. ft.	SFR-Basic
96 106679 RK	PRD-9,600	Residential 9,600 sq. ft.	SFR-Basic
96 108088 RK	PRD-9,600	Residential 9,600 sq. ft.	SFR-Basic
96 107222 RK	PRD-9,600	Residential 9,600 sq. ft.	SFR-Basic
96 107298 RK	PRD-9,600	Residential 9,600 sq. ft.	SFR-Basic
96 104407 RK	PRD-9,600	Residential 9,600 sq. ft.	Single Family Res-Combo
96 102879 RK	PRD-9,600	Residential 9,600 sq. ft.	SFR-Basic
96 105952 RK	PRD-9,600	Residential 9,600 sq. ft.	SFR-Basic
96 107225 RK	PRD-9,600	Residential 9,600 sq. ft.	SFR-Basic
96 107883 RK	PRD-9,600	Residential 9,600 sq. ft.	SFR-Basic
96 103508 RK	PRD-9,600	Residential 9,600 sq. ft.	SFR-Basic
96 107220 RK	PRD-9,600	Residential 9,600 sq. ft.	SFR-Basic
96 104214 RK	PRD-9,600	Residential 9,600 sq. ft.	SFR-Basic
96 107304 RK	PRD-9,600	Residential 9,600 sq. ft.	SFR-Basic
96 108084 RK	PRD-9,600	Residential 9,600 sq. ft.	SFR-Basic
96 108738 RK	PRD-9,600	Residential 9,600 sq. ft.	SFR-Basic
96 106119 RK	PRD-9,600	Residential 9,600 sq. ft.	SFR-Basic
96 104211 RK	PRD-9,600	Residential 9,600 sq. ft.	SFR-Basic
96 103730 RK	PRD-9,600	Residential 9,600 sq. ft.	SFR-Basic
96 107300 RK	PRD-9,600	Residential 9,600 sq. ft.	SFR-Basic
96 108092 RK	PRD-9,600	Residential 9,600 sq. ft.	SFR-Basic
96 108093 RK	PRD-9,600	Residential 9,600 sq. ft.	SFR-Basic
96 110156 RK	PRD-9,600	Residential 9,600 sq. ft.	SFR-Basic
96 110158 RK	PRD-9,600	Residential 9,600 sq. ft.	SFR-Basic
96 105446 RK	RRT-10	Rural Resource Transition-10	Single Family Res-Combo
96 101925 RK	R-5	Rural-5 Acre	Single Family Res-Combo

Accessory Dwelling Units

Index # - File Name: 1.0022 - Single Family Dwellings Data\_Snohomish County.pdf

96 100510 RK	R-12,500	Residential 12,500 sq. ft.	Single Family Res-Combo
96 106160 RK	R-5	Rural-5 Acre	Single Family Res-Combo
96 107378 RK	CITY	City	Duplex-Combo
96 110274 MH	R-5	Rural-5 Acre	Double Wide
96 102863 RK	R-5	Rural-5 Acre	Single Family Res-Combo
96 109297 RK	R-5	Rural-5 Acre	Single Family Res-Combo
96 102972 RK	R-5	Rural-5 Acre	Single Family Res-Combo
96 109296 RK	R-5	Rural-5 Acre	Single Family Res-Combo
96 105238 RK	R-5	Rural-5 Acre	Single Family Res-Combo
96 104612 RK	R-5	Rural-5 Acre	Single Family Res-Combo
96 102424 RK	R-5	Rural-5 Acre	Single Family Res-Combo
96 110296 RK	CITY	City	Duplex-Combo
95 108652 RK	R-5	Rural-5 Acre	Single Family Res-Combo
95 108552 RK	F	Forestry	Single Family Res-Combo
96 108905 RK	R-7,200	Residential 7,200 sq. ft.	Single Family Res-Combo
95 109882 RK	R-5	Rural-5 Acre	Single Family Res-Combo
95 109149 RK	R-5	Rural-5 Acre	Single Family Res-Combo
96 106541 RK	R-5	Rural-5 Acre	Single Family Res-Combo
95 108446 MH	R-5	Rural-5 Acre	Double Wide
96 100782 RK	R-5	Rural-5 Acre	Single Family Res-Combo
95 110897 RK	R-5	Rural-5 Acre	Single Family Res-Combo
95 109386 MH	A-10	Agriculture-10 Acre	Double Wide
96 101234 RK	R-7,200	Residential 7,200 sq. ft.	Single Family Res-Combo
96 104123 MH	F	Forestry	Single Wide
96 106955 RK	R-5	Rural-5 Acre	SFR-Basic
96 109338 MH	R-5	Rural-5 Acre	Double Wide
95 110808 MH	R-5	Rural-5 Acre	Double Wide
96 101047 RK	R-7,200	Residential 7,200 sq. ft.	Single Family Res-Combo
96 106193 RK	R-9,600	Residential 9,600 sq. ft.	SFR-Basic
96 102394 RK	R-9,600	Residential 9,600 sq. ft.	Single Family Res-Combo
96 105321 RK	R-9,600	Residential 9,600 sq. ft.	Single Family Res-Combo
96 102396 RK	R-9,600	Residential 9,600 sq. ft.	Single Family Res-Combo
96 102454 RK	R-9,600	Residential 9,600 sq. ft.	Single Family Res-Combo
96 102459 RK	R-9,600	Residential 9,600 sq. ft.	Single Family Res-Combo
96 105503 RK	R-9,600	Residential 9,600 sq. ft.	SFR-Basic
96 105572 RK	R-9,600	Residential 9,600 sq. ft.	SFR-Basic
96 106196 RK	R-9,600	Residential 9,600 sq. ft.	SFR-Basic
96 101846 RK	R-9,600	Residential 9,600 sq. ft.	Single Family Res-Combo
96 101010 RK	R-9,600	Residential 9,600 sq. ft.	Single Family Res-Combo
96 100721 RK	R-9,600	Residential 9,600 sq. ft.	Single Family Res-Combo
96 101356 RK	R-9,600	Residential 9,600 sq. ft.	SFR-Basic
96 101357 RK	R-9,600	Residential 9,600 sq. ft.	SFR-Basic
96 102049 RK	R-9,600	Residential 9,600 sq. ft.	Single Family Res-Combo
96 102047 RK	R-9,600	Residential 9,600 sq. ft.	Single Family Res-Combo
95 107562 RK	R-9,600	Residential 9,600 sq. ft.	Single Family Res-Combo
96 102046 RK	R-9,600	Residential 9,600 sq. ft.	Single Family Res-Combo
96 102051 RK	R-9,600	Residential 9,600 sq. ft.	Single Family Res-Combo

Accessory Dwelling Units

Index # - File Name: 1.0022 - Single Family Dwellings Data\_Snohomish County.pdf

95 110154 RK	R-9,600	Residential 9,600 sq. ft.	Single Family Res-Combo
96 100675 RK	R-9,600	Residential 9,600 sq. ft.	Single Family Res-Combo
96 102243 RK	R-9,600	Residential 9,600 sq. ft.	Single Family Res-Combo
96 102898 RK	R-9,600	Residential 9,600 sq. ft.	Single Family Res-Combo
96 103131 RK	R-9,600	Residential 9,600 sq. ft.	Single Family Res-Combo
96 107282 RK	R-7,200	Residential 7,200 sq. ft.	SFR-Basic
96 106513 RK	R-5	Rural-5 Acre	Single Family Res-Combo
96 109723 RK	R-7,200	Residential 7,200 sq. ft.	SFR-Basic
96 102253 RK	R-7,200	Residential 7,200 sq. ft.	Single Family Res-Combo
96 101644 RK	R-7,200	Residential 7,200 sq. ft.	SFR-Basic
96 104656 RK	R-7,200	Residential 7,200 sq. ft.	Single Family Res-Combo
96 107093 RK	R-7,200	Residential 7,200 sq. ft.	Single Family Res-Combo
96 102563 RK	R-7,200	Residential 7,200 sq. ft.	SFR-Basic
96 102556 RK	R-7,200	Residential 7,200 sq. ft.	Single Family Res-Combo
96 102558 RK	R-7,200	Residential 7,200 sq. ft.	Single Family Res-Combo
96 100490 RK	R-7,200	Residential 7,200 sq. ft.	Single Family Res-Combo
96 102934 RK	R-7,200	Residential 7,200 sq. ft.	Single Family Res-Combo
95 107048 RK	R-5	Rural-5 Acre	Single Family Res-Combo
96 106544 RK	R-5	Rural-5 Acre	Single Family Res-Combo
96 102917 RK	R-5	Rural-5 Acre	Single Family Res-Combo
96 102919 RK	R-5	Rural-5 Acre	Single Family Res-Combo
96 100649 MH	R-5	Rural-5 Acre	Double Wide
96 106965 RK	R-5	Rural-5 Acre	Single Family Res-Combo
96 100326 RK	A-10	Agriculture-10 Acre	Single Family Res-Combo
96 101165 RK	PRD SA-1	Suburban Agriculture-1 Acre	Single Family Res-Combo
96 105550 RK	PRD SA-1	Suburban Agriculture-1 Acre	SFR-Basic
96 103560 RK	PRD SA-1	Suburban Agriculture-1 Acre	SFR-Basic
96 100873 RK	PRD SA-1	Suburban Agriculture-1 Acre	Single Family Res-Combo
96 100303 RK	PRD SA-1	Suburban Agriculture-1 Acre	Single Family Res-Combo
96 101032 RK	PRD SA-1	Suburban Agriculture-1 Acre	Single Family Res-Combo
96 101030 RK	PRD SA-1	Suburban Agriculture-1 Acre	Single Family Res-Combo
96 102455 RK	PRD SA-1	Suburban Agriculture-1 Acre	Single Family Res-Combo
96 100871 RK	PRD SA-1	Suburban Agriculture-1 Acre	Single Family Res-Combo
96 102450 RK	PRD SA-1	Suburban Agriculture-1 Acre	Single Family Res-Combo
96 105471 RK	R-5	Rural-5 Acre	Single Family Res-Combo
96 100598 RK	R-5	Rural-5 Acre	Single Family Res-Combo
96 100929 RK	R-5	Rural-5 Acre	Single Family Res-Combo
96 101698 RK	R-5	Rural-5 Acre	Single Family Res-Combo
96 106587 MH	R-5	Rural-5 Acre	Double Wide
96 100325 RK	A-10	Agriculture-10 Acre	Single Family Res-Combo
96 104203 RK	A-10	Agriculture-10 Acre	Single Family Res-Combo
96 104207 RK	A-10	Agriculture-10 Acre	Single Family Res-Combo
96 100807 RK	R-5	Rural-5 Acre	Single Family Res-Combo
96 103511 RK	F	Forestry	Single Family Res-Combo
96 107971 MH	NB	Neighborhood Business	MH Park-Double Wide
96 100879 RK	R-5	Rural-5 Acre	Single Family Res-Combo
95 107863 RK	R-5	Rural-5 Acre	Single Family Res-Combo

Accessory Dwelling Units

Index # - File Name: 1.0022 - Single Family Dwellings Data\_Snohomish County.pdf

95 110758 RK	R-5	Rural-5 Acre	Single Family Res-Combo
96 108173 RK	TRIBES	Native American Land	Single Family Res-Combo
95 110891 RK	R-5	Rural-5 Acre	Single Family Res-Combo
96 100862 RK	MR	Multiple Residential	Duplex-Combo
95 106332 RK	R-9,600	Residential 9,600 sq. ft.	Single Family Res-Combo
96 108667 RK	PRD-9,600	Residential 9,600 sq. ft.	SFR-Basic
96 105838 RK	PRD-9,600	Residential 9,600 sq. ft.	SFR-Basic
96 106337 RK	PRD-9,600	Residential 9,600 sq. ft.	SFR-Basic
96 106747 RK	PRD-9,600	Residential 9,600 sq. ft.	SFR-Basic
96 104555 RK	PRD-9,600	Residential 9,600 sq. ft.	SFR-Basic
96 108344 RK	PRD-9,600	Residential 9,600 sq. ft.	SFR-Basic
96 110198 RK	PRD-9,600	Residential 9,600 sq. ft.	SFR-Basic
96 109305 RK	PRD-9,600	Residential 9,600 sq. ft.	SFR-Basic
96 109572 RK	PRD-9,600	Residential 9,600 sq. ft.	SFR-Basic
96 106857 RK	PRD-9,600	Residential 9,600 sq. ft.	SFR-Basic
96 107032 RK	PRD-9,600	Residential 9,600 sq. ft.	SFR-Basic
96 106335 RK	PRD-9,600	Residential 9,600 sq. ft.	SFR-Basic
96 104212 RK	PRD-9,600	Residential 9,600 sq. ft.	SFR-Basic
96 102272 RK	PRD-9,600	Residential 9,600 sq. ft.	SFR-Basic
96 105143 RK	R-5	Rural-5 Acre	Single Family Res-Combo
96 102019 RK	R-5	Rural-5 Acre	Single Family Res-Combo
96 102063 RK	CITY	City	Single Family Res-Combo
96 105284 MH	CITY	City	MH Park-Double Wide
96 104045 RK	PRD-LDMR	Low Density Multiple Reside	SFR-Basic
96 103057 RK	R-5	Rural-5 Acre	Single Family Res-Combo
95 110388 RK	R-5	Rural-5 Acre	Single Family Res-Combo
96 104046 RK	PRD-LDMR	Low Density Multiple Reside	SFR-Basic
96 104047 RK	PRD-LDMR	Low Density Multiple Reside	SFR-Basic
96 104049 RK	PRD-LDMR	Low Density Multiple Reside	SFR-Basic
96 106007 RK	PRD-LDMR	Low Density Multiple Reside	SFR-Basic
96 106008 RK	PRD-LDMR	Low Density Multiple Reside	SFR-Basic
96 106009 RK	PRD-LDMR	Low Density Multiple Reside	SFR-Basic
96 106010 RK	PRD-LDMR	Low Density Multiple Reside	SFR-Basic
96 105516 RK	PRD-LDMR	Low Density Multiple Reside	SFR-Basic
96 105517 RK	PRD-LDMR	Low Density Multiple Reside	SFR-Basic
96 105519 RK	PRD-LDMR	Low Density Multiple Reside	SFR-Basic
96 105520 RK	PRD-LDMR	Low Density Multiple Reside	SFR-Basic
95 107329 RK	PRD-LDMR	Low Density Multiple Reside	Single Family Res-Combo
95 106034 RK	PRD-LDMR	Low Density Multiple Reside	Single Family Res-Combo
96 100884 RK	PRD-LDMR	Low Density Multiple Reside	Single Family Res-Combo
96 108654 RK	PRD-LDMR	Low Density Multiple Reside	SFR-Basic
96 108653 RK	PRD-LDMR	Low Density Multiple Reside	SFR-Basic
96 108652 RK	PRD-LDMR	Low Density Multiple Reside	SFR-Basic
96 108651 RK	PRD-LDMR	Low Density Multiple Reside	SFR-Basic
96 108650 RK	PRD-LDMR	Low Density Multiple Reside	SFR-Basic
96 108649 RK	PRD-LDMR	Low Density Multiple Reside	SFR-Basic
96 108647 RK	PRD-LDMR	Low Density Multiple Reside	SFR-Basic

Accessory Dwelling Units

Index # - File Name: 1.0022 - Single Family Dwellings Data\_Snohomish County.pdf

96 108646 RK	PRD-LDMR	Low Density Multiple Reside	SFR-Basic
96 108239 RK	PRD-LDMR	Low Density Multiple Reside	SFR-Basic
96 108243 RK	PRD-LDMR	Low Density Multiple Reside	SFR-Basic
96 108245 RK	PRD-LDMR	Low Density Multiple Reside	SFR-Basic
96 108246 RK	PRD-LDMR	Low Density Multiple Reside	SFR-Basic
96 103236 RK	PRD-LDMR	Low Density Multiple Reside	SFR-Basic
96 103242 RK	PRD-LDMR	Low Density Multiple Reside	SFR-Basic
96 103244 RK	PRD-LDMR	Low Density Multiple Reside	SFR-Basic
96 103246 RK	PRD-LDMR	Low Density Multiple Reside	SFR-Basic
96 101692 RK	PRD-LDMR	Low Density Multiple Reside	SFR-Basic
96 100883 RK	PRD-LDMR	Low Density Multiple Reside	Single Family Res-Combo
96 101690 RK	PRD-LDMR	Low Density Multiple Reside	SFR-Basic
96 108139 RK	R-5	Rural-5 Acre	Single Family Res-Combo
96 107011 RK	R-5	Rural-5 Acre	Single Family Res-Combo
96 100387 RK	R-5	Rural-5 Acre	Single Family Res-Combo
96 106036 RK	R-5	Rural-5 Acre	Single Family Res-Combo
96 103361 RK	R-5	Rural-5 Acre	Single Family Res-Combo
96 103059 RK	LDMR	Low Density Multiple Reside	Single Family Res-Combo
96 103062 RK	LDMR	Low Density Multiple Reside	Duplex-Combo
96 107803 RK	R-5	Rural-5 Acre	Single Family Res-Combo
96 104907 RK	R-5	Rural-5 Acre	Single Family Res-Combo
96 102319 RK	R-5	Rural-5 Acre	Single Family Res-Combo
95 109671 RK	R-5	Rural-5 Acre	Single Family Res-Combo
95 105649 RK	SA-1	Suburban Agriculture-1 Acre	Single Family Res-Combo
95 105647 RK	SA-1	Suburban Agriculture-1 Acre	Single Family Res-Combo
96 104829 RK	R-9,600	Residential 9,600 sq. ft.	Single Family Res-Combo
96 105866 RK	R-5	Rural-5 Acre	Single Family Res-Combo
96 107080 RK	R-5	Rural-5 Acre	Single Family Res-Combo
96 100430 RK	CITY	City	Single Family Res-Combo
96 106443 RK	PRD-9,600	Residential 9,600 sq. ft.	Single Family Res-Combo
96 106064 RK	R-5	Rural-5 Acre	Single Family Res-Combo
96 104265 RK	R-9,600	Residential 9,600 sq. ft.	Single Family Res-Combo
96 103058 RK	R-9,600	Residential 9,600 sq. ft.	SFR-Basic
96 102150 RK	R-9,600	Residential 9,600 sq. ft.	Single Family Res-Combo
95 110033 RK	R-9,600	Residential 9,600 sq. ft.	Single Family Res-Combo
96 102148 RK	R-9,600	Residential 9,600 sq. ft.	Single Family Res-Combo
95 110425 RK	R-9,600	Residential 9,600 sq. ft.	Single Family Res-Combo
96 102012 RK	R-9,600	Residential 9,600 sq. ft.	Single Family Res-Combo
95 110638 RK	R-9,600	Residential 9,600 sq. ft.	Single Family Res-Combo
96 103880 RK	R-9,600	Residential 9,600 sq. ft.	Single Family Res-Combo
96 102118 RK	R-9,600	Residential 9,600 sq. ft.	Single Family Res-Combo
96 107763 RK	R-9,600	Residential 9,600 sq. ft.	Single Family Res-Combo
96 100390 RK	R-9,600	Residential 9,600 sq. ft.	Single Family Res-Combo
95 110842 RK	R-9,600	Residential 9,600 sq. ft.	Single Family Res-Combo
96 107443 RK	PRD-9,600	Residential 9,600 sq. ft.	Single Family Res-Combo
96 103510 RK	PRD-9,600	Residential 9,600 sq. ft.	Single Family Res-Combo
96 109302 RK	PRD-9,600	Residential 9,600 sq. ft.	Single Family Res-Combo

Accessory Dwelling Units

Index # - File Name: 1.0022 - Single Family Dwellings Data\_Snohomish County.pdf

96 103499 RK	PRD-9,600	Residential 9,600 sq. ft.	Single Family Res-Combo
95 109672 RK	R-5	Rural-5 Acre	Single Family Res-Combo
96 107732 RK	PRD-9,600	Residential 9,600 sq. ft.	Single Family Res-Combo
96 102729 RK	PRD-9,600	Residential 9,600 sq. ft.	Single Family Res-Combo
96 105507 RK	PRD-9,600	Residential 9,600 sq. ft.	Single Family Res-Combo
96 107055 RK	PRD-9,600	Residential 9,600 sq. ft.	SFR-Basic
96 108706 RK	PRD-9,600	Residential 9,600 sq. ft.	Single Family Res-Combo
96 105019 RK	PRD-9,600	Residential 9,600 sq. ft.	Single Family Res-Combo
96 105021 RK	PRD-9,600	Residential 9,600 sq. ft.	Single Family Res-Combo
96 105023 RK	PRD-9,600	Residential 9,600 sq. ft.	Single Family Res-Combo
96 109218 RK	PRD-9,600	Residential 9,600 sq. ft.	Single Family Res-Combo
96 102994 RK	CITY	City	SFR-Basic
96 109855 RK	CITY	City	SFR-Basic
96 110009 RK	CITY	City	SFR-Basic
96 103763 RK	PRD-9,600	Residential 9,600 sq. ft.	SFR-Basic
96 103755 RK	PRD-9,600	Residential 9,600 sq. ft.	Single Family Res-Combo
96 103758 RK	PRD-9,600	Residential 9,600 sq. ft.	Single Family Res-Combo
96 103765 RK	PRD-9,600	Residential 9,600 sq. ft.	SFR-Basic
96 103759 RK	PRD-9,600	Residential 9,600 sq. ft.	Single Family Res-Combo
96 102030 RK	PRD-9,600	Residential 9,600 sq. ft.	Single Family Res-Combo
96 107053 RK	PRD-9,600	Residential 9,600 sq. ft.	Single Family Res-Combo
96 102033 RK	PRD-9,600	Residential 9,600 sq. ft.	Single Family Res-Combo
96 101642 RK	CITY	City	Single Family Res-Combo
96 104620 RK	CITY	City	Single Family Res-Combo
96 102830 RK	CITY	City	Single Family Res-Combo
96 102207 RK	CITY	City	Single Family Res-Combo
96 102210 RK	CITY	City	Single Family Res-Combo
96 102262 RK	CITY	City	Single Family Res-Combo
96 102264 RK	CITY	City	Single Family Res-Combo
96 101883 RK	CITY	City	SFR-Basic
96 100787 RK	CITY	City	Single Family Res-Combo
96 100785 RK	CITY	City	Single Family Res-Combo
96 100784 RK	CITY	City	Single Family Res-Combo
96 100783 RK	CITY	City	Single Family Res-Combo
96 102265 RK	CITY	City	Single Family Res-Combo
96 104622 RK	CITY	City	Single Family Res-Combo
96 106536 RK	CITY	City	SFR-Basic
96 108128 RK	CITY	City	Single Family Res-Combo
96 102996 RK			SFR-Basic
96 104616 RK			Single Family Res-Combo
96 101643 RK	CITY	City	Single Family Res-Combo
96 100826 MH	F : RD	Forestry : Rural Diversificatic	Double Wide
96 103837 RK	R-5	Rural-5 Acre	Single Family Res-Combo
96 110335 RK	CITY	City	SFR-Basic
96 110557 RK	CITY	City	SFR-Basic
96 110556 RK	CITY	City	SFR-Basic
96 106928 RK	CITY	City	SFR-Basic



Accessory Dwelling Units

Index # - File Name: 1.0022 - Single Family Dwellings Data\_Snohomish County.pdf

96 106923 RK	CITY	City	SFR-Basic
96 106927 RK	CITY	City	SFR-Basic
96 106922 RK	CITY	City	SFR-Basic
96 108634 RK	CITY	City	SFR-Basic
96 108637 RK	CITY	City	SFR-Basic
96 108640 RK	CITY	City	SFR-Basic
96 108636 RK	CITY	City	SFR-Basic
96 109806 RK	CITY	City	SFR-Basic
96 100004 RK	PRD SA-1	Suburban Agriculture-1 Acre	Single Family Res-Combo
96 101345 RK	CITY	City	Duplex-Combo
96 104359 RK	CITY	City	Duplex-Combo
96 107018 RK	CITY	City	Duplex-Combo
96 105125 RK	PRD SA-1	Suburban Agriculture-1 Acre	Single Family Res-Combo
96 101485 RK	PRD SA-1	Suburban Agriculture-1 Acre	Single Family Res-Combo
96 100002 RK	PRD SA-1	Suburban Agriculture-1 Acre	Single Family Res-Combo
96 103780 RK	PRD SA-1	Suburban Agriculture-1 Acre	Single Family Res-Combo
96 100831 RK	PRD SA-1	Suburban Agriculture-1 Acre	Single Family Res-Combo
95 110371 RK	PRD SA-1	Suburban Agriculture-1 Acre	Single Family Res-Combo
96 107965 RK	CITY	City	SFR-Basic
96 109803 RK	CITY	City	SFR-Basic
96 109805 RK	CITY	City	SFR-Basic
96 107960 RK	CITY	City	SFR-Basic
96 107964 RK	CITY	City	SFR-Basic
96 110336 RK	CITY	City	SFR-Basic
96 110558 RK	CITY	City	SFR-Basic
96 108599 RK	R-5	Rural-5 Acre	Single Family Res-Combo
96 102646 RK	R-5	Rural-5 Acre	Single Family Res-Combo
96 103063 RK	R-5	Rural-5 Acre	Single Family Res-Combo
95 109673 RK	R-5	Rural-5 Acre	Single Family Res-Combo
96 110337 RK	CITY	City	SFR-Basic
96 109526 RK	CITY	City	SFR-Basic
96 109521 RK	CITY	City	SFR-Basic
96 107963 RK	CITY	City	SFR-Basic
96 107961 RK	CITY	City	SFR-Basic
96 106926 RK	CITY	City	SFR-Basic
96 106924 RK	CITY	City	SFR-Basic
96 108633 RK	CITY	City	SFR-Basic
96 105993 RK	R-5	Rural-5 Acre	Single Family Res-Combo
96 104331 RK	R-5	Rural-5 Acre	Single Family Res-Combo
96 102018 RK	R-5	Rural-5 Acre	Single Family Res-Combo
96 107821 RK	R-5	Rural-5 Acre	Single Family Res-Combo
96 108107 RK	CITY	City	SFR-Basic
96 108106 RK	CITY	City	SFR-Basic
96 108842 RK	CITY	City	SFR-Basic
96 108841 RK	CITY	City	SFR-Basic
96 110746 RK	CITY	City	SFR-Basic
96 109773 RK	CITY	City	SFR-Basic

Accessory Dwelling Units

Index # - File Name: 1.0022 - Single Family Dwellings Data\_Snohomish County.pdf

96 108845 RK	CITY	City	SFR-Basic
96 107881 RK	CITY	City	SFR-Basic
96 104889 RK	CITY	City	SFR-Basic
95 109641 RK	CITY	City	Single Family Res-Combo
96 105477 RK	CITY	City	SFR-Basic
96 105476 RK	CITY	City	SFR-Basic
95 107434 RK	CITY	City	Single Family Res-Combo
96 103742 RK	CITY	City	SFR-Basic
95 109642 RK	CITY	City	Single Family Res-Combo
96 102734 RK	CITY	City	SFR-Basic
96 110190 RK	CITY	City	SFR-Basic
96 103437 RK	CITY	City	SFR-Basic
96 103417 RK	CITY	City	SFR-Basic
96 102436 RK	CITY	City	Single Family Res-Combo
96 101489 RK	CITY	City	Single Family Res-Combo
96 101488 RK	CITY	City	Single Family Res-Combo
96 101492 RK	CITY	City	Single Family Res-Combo
96 101491 RK	CITY	City	Single Family Res-Combo
96 104385 RK	CITY	City	SFR-Basic
96 104386 RK	CITY	City	SFR-Basic
96 104794 RK	CITY	City	SFR-Basic
96 103640 RK	CITY	City	SFR-Basic
96 104387 RK	CITY	City	SFR-Basic
96 105456 RK	CITY	City	SFR-Basic
96 105454 RK	CITY	City	SFR-Basic
96 105455 RK	CITY	City	SFR-Basic
96 110333 RK	CITY	City	SFR-Basic
96 110332 RK	CITY	City	SFR-Basic
96 109527 RK	CITY	City	SFR-Basic
96 108425 RK	CITY	City	Single Family Res-Combo
96 107637 RK	CITY	City	SFR-Basic
96 105850 RK	CITY	City	SFR-Basic
96 105849 RK	CITY	City	SFR-Basic
96 105848 RK	CITY	City	SFR-Basic
96 105846 RK	CITY	City	SFR-Basic
96 105845 RK	CITY	City	SFR-Basic
96 105844 RK	CITY	City	SFR-Basic
96 103588 RK	CITY	City	SFR-Basic
96 110191 RK	CITY	City	SFR-Basic
96 110192 RK	CITY	City	SFR-Basic
96 107860 RK	R-5	Rural-5 Acre	Single Family Res-Combo
96 105619 RK	R-9,600	Residential 9,600 sq. ft.	SFR-Basic
96 106159 RK	R-9,600	Residential 9,600 sq. ft.	Single Family Res-Combo
96 105625 RK	R-9,600	Residential 9,600 sq. ft.	SFR-Basic
96 106413 RK	R-5	Rural-5 Acre	Single Family Res-Combo
96 108336 RK	R-5	Rural-5 Acre	Single Family Res-Combo
95 105066 RK	RD	Rural Diversification	Single Family Res-Combo

Accessory Dwelling Units

Index # - File Name: 1.0022 - Single Family Dwellings Data\_Snohomish County.pdf

96 105605 RK	R-9,600	Residential 9,600 sq. ft.	Single Family Res-Combo
96 105602 RK	R-9,600	Residential 9,600 sq. ft.	Single Family Res-Combo
96 105263 RK	R-5	Rural-5 Acre	Single Family Res-Combo
96 100578 MH	R-5	Rural-5 Acre	Double Wide
95 106307 RK	PRD-9,600	Residential 9,600 sq. ft.	Single Family Res-Combo
96 102920 RK	PRD-9,600	Residential 9,600 sq. ft.	Single Family Res-Combo
96 101187 RK	PRD-9,600	Residential 9,600 sq. ft.	Single Family Res-Combo
96 102927 RK	PRD-9,600	Residential 9,600 sq. ft.	Single Family Res-Combo
96 100334 RK	PRD-9,600	Residential 9,600 sq. ft.	Single Family Res-Combo
96 109228 RK	PRD-9,600	Residential 9,600 sq. ft.	Single Family Res-Combo
96 106461 RK	PRD-9,600	Residential 9,600 sq. ft.	SFR-Basic
96 105782 RK	PRD-9,600	Residential 9,600 sq. ft.	Single Family Res-Combo
96 101924 RK	PRD-9,600	Residential 9,600 sq. ft.	Single Family Res-Combo
96 104148 RK	PRD-9,600	Residential 9,600 sq. ft.	Single Family Res-Combo
95 110793 RK	PRD-9,600	Residential 9,600 sq. ft.	Single Family Res-Combo
96 104692 RK	PRD-9,600	Residential 9,600 sq. ft.	Single Family Res-Combo
95 110794 RK	PRD-9,600	Residential 9,600 sq. ft.	Single Family Res-Combo
96 105374 RK	PRD-9,600	Residential 9,600 sq. ft.	SFR-Basic
96 101195 RK	PRD-9,600	Residential 9,600 sq. ft.	Single Family Res-Combo
96 104539 RK	PRD-9,600	Residential 9,600 sq. ft.	Single Family Res-Combo
96 100890 RK	PRD-9,600	Residential 9,600 sq. ft.	Single Family Res-Combo
95 109491 RK	PRD-9,600	Residential 9,600 sq. ft.	Single Family Res-Combo
96 102378 RK	PRD-9,600	Residential 9,600 sq. ft.	SFR-Basic
95 106932 RK	PRD-9,600	Residential 9,600 sq. ft.	Single Family Res-Combo
96 104368 RK	PRD-9,600	Residential 9,600 sq. ft.	Single Family Res-Combo
95 107471 RK	PRD-9,600	Residential 9,600 sq. ft.	Single Family Res-Combo
96 107267 RK	PRD-9,600	Residential 9,600 sq. ft.	Single Family Res-Combo
96 109356 RK	PRD-9,600	Residential 9,600 sq. ft.	SFR-Basic
95 106311 RK	PRD-9,600	Residential 9,600 sq. ft.	Single Family Res-Combo
96 104774 RK	PRD-9,600	Residential 9,600 sq. ft.	Single Family Res-Combo
96 101373 RK	PRD-9,600	Residential 9,600 sq. ft.	Single Family Res-Combo
96 104770 RK	PRD-9,600	Residential 9,600 sq. ft.	Single Family Res-Combo
96 103129 RK	PRD-9,600	Residential 9,600 sq. ft.	Single Family Res-Combo
96 102770 RK	PRD-9,600	Residential 9,600 sq. ft.	Single Family Res-Combo
96 104772 RK	PRD-9,600	Residential 9,600 sq. ft.	Single Family Res-Combo
96 103183 RK	PRD-9,600	Residential 9,600 sq. ft.	Single Family Res-Combo
96 104779 RK	PRD-9,600	Residential 9,600 sq. ft.	Single Family Res-Combo
96 106344 RK	PRD-9,600	Residential 9,600 sq. ft.	Single Family Res-Combo
96 102375 RK	PRD-9,600	Residential 9,600 sq. ft.	Single Family Res-Combo
96 102501 RK	PRD-9,600	Residential 9,600 sq. ft.	Single Family Res-Combo
96 102503 RK	PRD-9,600	Residential 9,600 sq. ft.	Single Family Res-Combo
96 102504 RK	PRD-9,600	Residential 9,600 sq. ft.	Single Family Res-Combo
96 108801 RK	R-8,400	Residential 8,400 sq. ft.	SFR-Basic
96 108958 RK	R-8,400	Residential 8,400 sq. ft.	Single Family Res-Combo
96 108798 RK	R-8,400	Residential 8,400 sq. ft.	Single Family Res-Combo
96 107173 RK	R-8,400	Residential 8,400 sq. ft.	Single Family Res-Combo
96 104855 RK	R-5	Rural-5 Acre	Single Family Res-Combo

Accessory Dwelling Units

Index # - File Name: 1.0022 - Single Family Dwellings Data\_Snohomish County.pdf

96 107176 RK	R-8,400	Residential 8,400 sq. ft.	Single Family Res-Combo
96 102787 RK	CITY	City	SFR-Basic
96 102794 RK	CITY	City	SFR-Basic
96 102795 RK	CITY	City	SFR-Basic
96 102788 RK	CITY	City	SFR-Basic
96 103644 RK	CITY	City	SFR-Basic
96 103643 RK	CITY	City	SFR-Basic
96 103642 RK	CITY	City	SFR-Basic
96 104381 RK	CITY	City	SFR-Basic
96 105851 RK	CITY	City	SFR-Basic
96 105852 RK	CITY	City	SFR-Basic
96 104379 RK	CITY	City	SFR-Basic
96 104383 RK	CITY	City	SFR-Basic
96 103419 RK	CITY	City	SFR-Basic
96 103416 RK	CITY	City	SFR-Basic
96 103438 RK	CITY	City	SFR-Basic
96 103423 RK	CITY	City	SFR-Basic
96 102782 RK	CITY	City	SFR-Basic
96 109230 RK	PRD-9,600	Residential 9,600 sq. ft.	Single Family Res-Combo
96 100673 RK	PRD-9,600	Residential 9,600 sq. ft.	Single Family Res-Combo
96 104128 RK	R-5	Rural-5 Acre	Single Family Res-Combo
95 101466 RK	R-5	Rural-5 Acre	Single Family Res-Combo
96 104596 RK	R-5	Rural-5 Acre	Single Family Res-Combo
96 104814 RK	R-5	Rural-5 Acre	Single Family Res-Combo
96 109221 RK	R-5	Rural-5 Acre	Single Family Res-Combo
96 110084 RK	R-5	Rural-5 Acre	Single Family Res-Combo
96 105657 RK	R-5	Rural-5 Acre	Single Family Res-Combo
96 108702 RK	R-5	Rural-5 Acre	Single Family Res-Combo
96 103194 RK	R-5	Rural-5 Acre	SFR-Basic
95 110679 RK	R-5	Rural-5 Acre	Single Family Res-Combo
95 110681 RK	R-5	Rural-5 Acre	Single Family Res-Combo
96 108416 RK	R-5	Rural-5 Acre	Single Family Res-Combo
96 101213 RK	R-5	Rural-5 Acre	Single Family Res-Combo
96 109087 RK	R-5	Rural-5 Acre	Single Family Res-Combo
95 109649 RK	R-5	Rural-5 Acre	Single Family Res-Combo
96 104342 RK	R-5	Rural-5 Acre	Single Family Res-Combo
96 101027 RK	R-5	Rural-5 Acre	Single Family Res-Combo
96 101028 RK	R-5	Rural-5 Acre	Single Family Res-Combo
95 110043 RK	R-9,600	Residential 9,600 sq. ft.	Single Family Res-Combo
96 105402 RK	R-9,600	Residential 9,600 sq. ft.	Single Family Res-Combo
96 103146 RK	R-9,600	Residential 9,600 sq. ft.	SFR-Basic
96 106355 RK	R-9,600	Residential 9,600 sq. ft.	Single Family Res-Combo
96 109409 RK	R-9,600	Residential 9,600 sq. ft.	SFR-Basic
96 103738 RK	R-9,600	Residential 9,600 sq. ft.	SFR-Basic
96 103152 RK	R-9,600	Residential 9,600 sq. ft.	SFR-Basic
96 106464 RK	R-5	Rural-5 Acre	Single Family Res-Combo
96 110327 RK	R-5	Rural-5 Acre	Single Family Res-Combo

Accessory Dwelling Units

Index # - File Name: 1.0022 - Single Family Dwellings Data\_Snohomish County.pdf

96 108697 MH	R-5	Rural-5 Acre	Double Wide
95 103803 MH	RC	Rural Conservation	Double Wide
96 106282 MH	RC	Rural Conservation	Single Wide
96 105445 RK	R-9,600	Residential 9,600 sq. ft.	SFR-Basic
96 108384 RK	R-9,600	Residential 9,600 sq. ft.	Single Family Res-Combo
96 104271 RK	R-5	Rural-5 Acre	Single Family Res-Combo
96 110141 RK	R-5	Rural-5 Acre	Single Family Res-Combo
96 106431 RK	R-5	Rural-5 Acre	Single Family Res-Combo
96 104942 RK	R-9,600	Residential 9,600 sq. ft.	Single Family Res-Combo
96 107575 RK	R-5	Rural-5 Acre	Single Family Res-Combo
96 103044 RK	R-5	Rural-5 Acre	Single Family Res-Combo
96 101308 RK	R-5	Rural-5 Acre	Single Family Res-Combo
96 109838 MH	R-5	Rural-5 Acre	Double Wide
96 100300 RK	R-5	Rural-5 Acre	Single Family Res-Combo
96 103532 RK	PRD-9,600	Residential 9,600 sq. ft.	Single Family Res-Combo
96 105258 RK	PRD-9,600	Residential 9,600 sq. ft.	Single Family Res-Combo
96 102373 RK	PRD-9,600	Residential 9,600 sq. ft.	Single Family Res-Combo
96 107628 MH	RRT-10	Rural Resource Transition-10	Triple Wide
96 109400 MH	MR	Multiple Residential	Double Wide
95 109527 RK	R-5	Rural-5 Acre	Duplex-Combo
96 100314 RK	PRD-9,600	Residential 9,600 sq. ft.	Single Family Res-Combo
96 108458 RK	PRD-9,600	Residential 9,600 sq. ft.	SFR-Basic
96 104688 RK	PRD-9,600	Residential 9,600 sq. ft.	SFR-Basic
96 103585 RK	PRD-9,600	Residential 9,600 sq. ft.	SFR-Basic
96 102763 RK	PRD-9,600	Residential 9,600 sq. ft.	SFR-Basic
96 102764 RK	PRD-9,600	Residential 9,600 sq. ft.	Single Family Res-Combo
95 104696 001 00 RK	PRD-9,600	Residential 9,600 sq. ft.	Single Family Res-Combo
96 110193 RK	PRD-9,600	Residential 9,600 sq. ft.	SFR-Basic
96 110196 RK	PRD-9,600	Residential 9,600 sq. ft.	Single Family Res-Combo
96 102619 RK	PRD-9,600	Residential 9,600 sq. ft.	SFR-Basic
95 104701 RK	PRD-9,600	Residential 9,600 sq. ft.	Single Family Res-Combo
96 110804 RK	PRD-9,600	Residential 9,600 sq. ft.	SFR-Basic
96 104400 RK	PRD-9,600	Residential 9,600 sq. ft.	SFR-Basic
95 104695 RK	PRD-9,600	Residential 9,600 sq. ft.	Single Family Res-Combo
96 102765 RK	PRD-9,600	Residential 9,600 sq. ft.	Single Family Res-Combo
96 101264 RK	RRT-10	Rural Resource Transition-10	Single Family Res-Combo
95 108451 RK	RRT-10	Rural Resource Transition-10	Single Family Res-Combo
96 105479 RK	R-9,600	Residential 9,600 sq. ft.	SFR-Basic
96 108574 RK	R-9,600	Residential 9,600 sq. ft.	SFR-Basic
96 106250 RK	R-9,600	Residential 9,600 sq. ft.	SFR-Basic
96 110748 RK	R-8,400	Residential 8,400 sq. ft.	SFR-Basic
96 107642 RK	R-9,600	Residential 9,600 sq. ft.	SFR-Basic
96 110749 RK	R-9,600	Residential 9,600 sq. ft.	SFR-Basic
96 110750 RK	R-9,600	Residential 9,600 sq. ft.	SFR-Basic
96 110201 RK	R-8,400	Residential 8,400 sq. ft.	SFR-Basic
96 110202 RK	R-8,400	Residential 8,400 sq. ft.	SFR-Basic
96 103340 RK	R-8,400	Residential 8,400 sq. ft.	SFR-Basic

Accessory Dwelling Units

Index # - File Name: 1.0022 - Single Family Dwellings Data\_Snohomish County.pdf

96 102074 RK	R-8,400	Residential 8,400 sq. ft.	Single Family Res-Combo
96 109777 RK	R-8,400	Residential 8,400 sq. ft.	SFR-Basic
96 107956 MH	R-5	Rural-5 Acre	Double Wide
96 106547 RK	R-9,600	Residential 9,600 sq. ft.	Single Family Res-Combo
96 106379 RK	R-5	Rural-5 Acre	Single Family Res-Combo
96 107245 RK	R-7,200	Residential 7,200 sq. ft.	SFR-Basic
96 106891 RK	R-7,200	Residential 7,200 sq. ft.	SFR-Basic
95 110490 RK	R-7,200	Residential 7,200 sq. ft.	Single Family Res-Combo
96 103535 RK	R-7,200	Residential 7,200 sq. ft.	SFR-Basic
96 102640 RK	RRT-10	Rural Resource Transition-10	Single Family Res-Combo
96 103106 RK	R-7,200 : R-9,600	Residential 7,200 sq. ft. : Residential 9,600 sq. ft.	Single Family Res-Combo
96 108222 RK	R-5	Rural-5 Acre	Single Family Res-Combo
96 100507 RK	RD	Rural Diversification	Single Family Res-Combo
94 131452 000 01 MH	R-5	Rural-5 Acre	Double Wide
96 100813 RK	R-5	Rural-5 Acre	Single Family Res-Combo
96 107264 RK	R-5	Rural-5 Acre	Single Family Res-Combo
96 102133 RK	R-5	Rural-5 Acre	Single Family Res-Combo
96 103335 RK	R-5	Rural-5 Acre	Single Family Res-Combo
95 109526 RK	R-5	Rural-5 Acre	Duplex-Combo
96 104891 RK	R-5	Rural-5 Acre	Single Family Res-Combo
96 106416 RK	R-9,600	Residential 9,600 sq. ft.	SFR-Basic
96 102420 RK	R-5	Rural-5 Acre	Single Family Res-Combo
96 107291 RK	R-9,600	Residential 9,600 sq. ft.	SFR-Basic
96 105633 RK	PRD-9,600	Residential 9,600 sq. ft.	SFR-Basic
96 101302 RK	PRD-9,600	Residential 9,600 sq. ft.	Single Family Res-Combo
96 110195 RK	PRD-9,600	Residential 9,600 sq. ft.	SFR-Basic
96 109791 MH	CITY	City	Double Wide
96 106212 RK	R-5	Rural-5 Acre	Single Family Res-Combo
96 109756 RK	CITY	City	SFR-Basic
96 106248 RK	PRD-9,600	Residential 9,600 sq. ft.	Single Family Res-Combo
96 106249 RK	PRD-9,600	Residential 9,600 sq. ft.	Single Family Res-Combo
96 100766 RK	R-5	Rural-5 Acre	Single Family Res-Combo
96 101500 RK	R-9,600	Residential 9,600 sq. ft.	Single Family Res-Combo
95 110787 MH	CITY	City	Double Wide
95 110827 RK	RD	Rural Diversification	Single Family Res-Combo
96 107098 RK	R-5	Rural-5 Acre	Single Family Res-Combo
96 107306 RK	PRD-9,600	Residential 9,600 sq. ft.	Single Family Res-Combo
96 109963 RK	PRD-9,600	Residential 9,600 sq. ft.	SFR-Basic
96 104157 RK	PRD-9,600	Residential 9,600 sq. ft.	Single Family Res-Combo
96 107190 RK	PRD-9,600	Residential 9,600 sq. ft.	Single Family Res-Combo
96 107766 RK	CITY	City	Single Family Res-Combo
95 110810 RK	R-9,600	Residential 9,600 sq. ft.	Single Family Res-Combo
96 106203 RK	PRD SA-1	Suburban Agriculture-1 Acre	Single Family Res-Combo
96 101210 RK	PRD SA-1	Suburban Agriculture-1 Acre	Single Family Res-Combo
96 107915 RK	PRD SA-1	Suburban Agriculture-1 Acre	SFR-Basic
96 108740 RK	PRD-9,600	Residential 9,600 sq. ft.	SFR-Basic
96 108739 RK	PRD-9,600	Residential 9,600 sq. ft.	SFR-Basic

Accessory Dwelling Units

Index # - File Name: 1.0022 - Single Family Dwellings Data\_Snohomish County.pdf

96 104868 RK	PRD-9,600	Residential 9,600 sq. ft.	SFR-Basic
96 106368 RK	PRD-9,600	Residential 9,600 sq. ft.	SFR-Basic
96 109563 RK	PRD-9,600	Residential 9,600 sq. ft.	SFR-Basic
96 101168 RK	PRD-9,600	Residential 9,600 sq. ft.	Single Family Res-Combo
95 110407 RK	PRD-9,600	Residential 9,600 sq. ft.	Single Family Res-Combo
96 106960 RK	PRD-9,600	Residential 9,600 sq. ft.	SFR-Basic
96 110159 RK	PRD-9,600	Residential 9,600 sq. ft.	SFR-Basic
96 103265 RK	PRD-9,600	Residential 9,600 sq. ft.	SFR-Basic
96 108742 RK	PRD-9,600	Residential 9,600 sq. ft.	SFR-Basic
96 103728 RK	PRD-9,600	Residential 9,600 sq. ft.	SFR-Basic
96 105094 RK	PRD-9,600	Residential 9,600 sq. ft.	SFR-Basic
96 109564 RK	PRD-9,600	Residential 9,600 sq. ft.	SFR-Basic
95 110634 RK	PRD-9,600	Residential 9,600 sq. ft.	Single Family Res-Combo
96 108294 RK	PRD-9,600	Residential 9,600 sq. ft.	SFR-Basic
96 107886 RK	PRD-9,600	Residential 9,600 sq. ft.	SFR-Basic
96 107297 RK	PRD-9,600	Residential 9,600 sq. ft.	SFR-Basic
96 109566 RK	PRD-9,600	Residential 9,600 sq. ft.	SFR-Basic
96 108744 RK	PRD-9,600	Residential 9,600 sq. ft.	SFR-Basic
96 108731 RK	PRD-9,600	Residential 9,600 sq. ft.	SFR-Basic
96 108745 RK	PRD-9,600	Residential 9,600 sq. ft.	SFR-Basic
96 108094 RK	PRD-9,600	Residential 9,600 sq. ft.	SFR-Basic
96 109565 RK	PRD-9,600	Residential 9,600 sq. ft.	SFR-Basic
96 106824 RK	CITY	City	SFR-Basic
96 109757 RK	CITY	City	SFR-Basic
96 108556 RK	CITY	City	Single Family Res-Combo
96 102963 RK	CITY	City	SFR-Basic
96 102964 RK	CITY	City	SFR-Basic
96 102965 RK	CITY	City	SFR-Basic
96 105054 RK	CITY	City	SFR-Basic
96 105056 RK	CITY	City	SFR-Basic
96 105057 RK	CITY	City	SFR-Basic
96 105058 RK	CITY	City	SFR-Basic
96 105059 RK	CITY	City	SFR-Basic
96 109759 RK	CITY	City	SFR-Basic
96 108553 RK	CITY	City	SFR-Basic
96 108554 RK	CITY	City	SFR-Basic
96 108555 RK	CITY	City	SFR-Basic
96 106823 RK	CITY	City	SFR-Basic
96 106821 RK	CITY	City	SFR-Basic
96 104651 RK	CITY	City	SFR-Basic
96 102967 RK	CITY	City	SFR-Basic
96 104652 RK	CITY	City	SFR-Basic
96 104654 RK	CITY	City	SFR-Basic
96 106453 RK	R-5	Rural-5 Acre	Single Family Res-Combo
96 103778 MH	R-5	Rural-5 Acre	Double Wide
96 105271 RK	LDMR	Low Density Multiple Reside	Duplex-Basic
96 103118 RK	R-9,600	Residential 9,600 sq. ft.	Single Family Res-Combo

Accessory Dwelling Units

Index # - File Name: 1.0022 - Single Family Dwellings Data\_Snohomish County.pdf

96 108746 RK	PRD-9,600	Residential 9,600 sq. ft.	SFR-Basic
96 108748 RK	PRD-9,600	Residential 9,600 sq. ft.	SFR-Basic
96 106681 RK	PRD-9,600	Residential 9,600 sq. ft.	SFR-Basic
96 103212 RK	PRD-9,600	Residential 9,600 sq. ft.	SFR-Basic
96 103505 RK	PRD-9,600	Residential 9,600 sq. ft.	Single Family Res-Combo
96 102139 RK	R-5	Rural-5 Acre	Single Family Res-Combo
96 105512 RK	R-5	Rural-5 Acre	Single Family Res-Combo
96 107603 RK	R-5	Rural-5 Acre	Single Family Res-Combo
96 103907 RK	R-5	Rural-5 Acre	Single Family Res-Combo
96 103539 RK	R-5	Rural-5 Acre	SFR-Basic
96 103038 RK	PRD-LDMR	Low Density Multiple Reside	SFR-Basic
96 103039 RK	PRD-LDMR	Low Density Multiple Reside	SFR-Basic
94 140301 RK	F	Forestry	Single Family Res-Combo
96 105707 MH	R-5	Rural-5 Acre	Double Wide
96 108576 RK	R-9,600	Residential 9,600 sq. ft.	Single Family Res-Combo
96 107370 RK	R-8,400	Residential 8,400 sq. ft.	Single Family Res-Combo
96 107367 RK	R-8,400	Residential 8,400 sq. ft.	Single Family Res-Combo
96 104582 RK	R-5	Rural-5 Acre	Duplex-Combo
95 107047 RK	R-5	Rural-5 Acre	Single Family Res-Combo
96 104534 RK	R-5	Rural-5 Acre	Single Family Res-Combo
96 101202 RK	RRT-10	Rural Resource Transition-10	Single Family Res-Combo
96 103094 RK	PRD-9,600	Residential 9,600 sq. ft.	Single Family Res-Combo
96 105585 RK	PRD-9,600	Residential 9,600 sq. ft.	SFR-Basic
96 104210 RK	PRD-9,600	Residential 9,600 sq. ft.	SFR-Basic
96 105489 RK	PRD-9,600	Residential 9,600 sq. ft.	SFR-Basic
96 102540 RK	PRD-9,600	Residential 9,600 sq. ft.	Single Family Res-Combo
96 102864 RK	PRD-9,600	Residential 9,600 sq. ft.	SFR-Basic
96 102869 RK	PRD-9,600	Residential 9,600 sq. ft.	SFR-Basic
96 104785 RK	PRD-9,600	Residential 9,600 sq. ft.	Single Family Res-Combo
96 105588 RK	PRD-9,600	Residential 9,600 sq. ft.	SFR-Basic
96 105486 RK	PRD-9,600	Residential 9,600 sq. ft.	SFR-Basic
96 105592 RK	PRD-9,600	Residential 9,600 sq. ft.	SFR-Basic
96 105484 RK	PRD-9,600	Residential 9,600 sq. ft.	SFR-Basic
96 105482 RK	PRD-9,600	Residential 9,600 sq. ft.	SFR-Basic
96 108902 RK	PRD-9,600	Residential 9,600 sq. ft.	SFR-Basic
96 108904 RK	PRD-9,600	Residential 9,600 sq. ft.	SFR-Basic
96 108906 RK	PRD-9,600	Residential 9,600 sq. ft.	SFR-Basic
96 108920 RK	PRD-9,600	Residential 9,600 sq. ft.	SFR-Basic
96 108922 RK	PRD-9,600	Residential 9,600 sq. ft.	SFR-Basic
96 108916 RK	PRD-9,600	Residential 9,600 sq. ft.	SFR-Basic
96 108918 RK	PRD-9,600	Residential 9,600 sq. ft.	SFR-Basic
96 108921 RK	PRD-9,600	Residential 9,600 sq. ft.	SFR-Basic
96 108924 RK	PRD-9,600	Residential 9,600 sq. ft.	SFR-Basic
96 109836 RK	PRD-9,600	Residential 9,600 sq. ft.	SFR-Basic
96 100876 RK	R-5	Rural-5 Acre	Single Family Res-Combo
95 110812 RK	R-5	Rural-5 Acre	Single Family Res-Combo
95 109774 RK	R-5	Rural-5 Acre	Single Family Res-Combo



Accessory Dwelling Units

Index # - File Name: 1.0022 - Single Family Dwellings Data\_Snohomish County.pdf

96 103278 RK	R-5	Rural-5 Acre	Single Family Res-Combo
96 108834 RK	R-5	Rural-5 Acre	Single Family Res-Combo
96 109039 RK	R-5	Rural-5 Acre	Single Family Res-Combo
96 108317 RK	R-5	Rural-5 Acre	Single Family Res-Combo
96 104040 RK	R-5	Rural-5 Acre	Single Family Res-Combo
96 108089 MH	R-5	Rural-5 Acre	Double Wide
96 103444 RK	R-5	Rural-5 Acre	Single Family Res-Combo
96 106777 MH	R-5	Rural-5 Acre	Single Wide
96 105160 RK	R-5	Rural-5 Acre	Single Family Res-Combo
96 101294 RK	R-5	Rural-5 Acre	Single Family Res-Combo
96 108307 RK	R-5	Rural-5 Acre	Single Family Res-Combo
94 140330 RK	F	Forestry	Single Family Res-Combo
96 108774 RK	R-5	Rural-5 Acre	Single Family Res-Combo
95 110354 RK	R-5	Rural-5 Acre	Single Family Res-Combo
96 108510 MH	R-5	Rural-5 Acre	Triple Wide
94 240260 RK	R-5	Rural-5 Acre	Single Family Res-Combo
96 105005 RK	R-9,600	Residential 9,600 sq. ft.	Single Family Res-Combo
96 100709 RK	R-9,600	Residential 9,600 sq. ft.	Single Family Res-Combo
96 102293 RK	R-9,600	Residential 9,600 sq. ft.	Single Family Res-Combo
96 103879 RK	R-9,600	Residential 9,600 sq. ft.	Single Family Res-Combo
96 105521 RK	R-5	Rural-5 Acre	Single Family Res-Combo
96 100364 RK	R-5	Rural-5 Acre	Single Family Res-Combo
96 105013 RK	R-9,600	Residential 9,600 sq. ft.	Single Family Res-Combo
96 106061 RK	R-5	Rural-5 Acre	Single Family Res-Combo
96 107908 RK	R-5	Rural-5 Acre	Single Family Res-Combo
96 108809 MH	R-5	Rural-5 Acre	Double Wide
96 101428 RK	R-5	Rural-5 Acre	Single Family Res-Combo
96 101421 RK	R-5	Rural-5 Acre	Single Family Res-Combo
95 110636 RK	CITY	City	Duplex-Combo
96 106784 MH	R-5	Rural-5 Acre	Double Wide
96 106133 RK	R-5	Rural-5 Acre	Single Family Res-Combo
96 104353 RK	R-5	Rural-5 Acre	Single Family Res-Combo
96 104860 RK	CITY	City	Duplex-Combo
96 100252 RK	R-5	Rural-5 Acre	Single Family Res-Combo
96 109067 MH	R-5	Rural-5 Acre	Double Wide
96 108017 MH	CITY	City	MH Park-Double Wide
96 106164 RK	R-9,600	Residential 9,600 sq. ft.	Single Family Res-Combo
96 108015 RK	R-9,600	Residential 9,600 sq. ft.	SFR-Basic
96 108013 RK	R-9,600	Residential 9,600 sq. ft.	SFR-Basic
96 107937 RK	R-5	Rural-5 Acre	Single Family Res-Combo
96 107978 MH	CITY	City	MH Park-Double Wide
96 107689 RK	R-9,600	Residential 9,600 sq. ft.	Single Family Res-Combo
96 108126 RK	R-8,400	Residential 8,400 sq. ft.	SFR-Basic
96 108117 RK	R-8,400	Residential 8,400 sq. ft.	SFR-Basic
96 108120 RK	R-8,400	Residential 8,400 sq. ft.	SFR-Basic
96 108124 RK	R-8,400	Residential 8,400 sq. ft.	SFR-Basic
96 108125 RK	R-8,400	Residential 8,400 sq. ft.	SFR-Basic

Accessory Dwelling Units

Index # - File Name: 1.0022 - Single Family Dwellings Data\_Snohomish County.pdf

96 108121 RK	R-8,400	Residential 8,400 sq. ft.	SFR-Basic
96 108122 RK	R-8,400	Residential 8,400 sq. ft.	SFR-Basic
96 108119 RK	R-8,400	Residential 8,400 sq. ft.	SFR-Basic
96 108116 RK	R-8,400	Residential 8,400 sq. ft.	SFR-Basic
96 108123 RK	R-8,400	Residential 8,400 sq. ft.	SFR-Basic
96 108115 RK	R-8,400	Residential 8,400 sq. ft.	SFR-Basic
96 108004 RK	LDMR	Low Density Multiple Reside Duplex-Basic	
96 108005 RK	LDMR	Low Density Multiple Reside Duplex-Basic	
96 108007 RK	LDMR	Low Density Multiple Reside Duplex-Basic	
96 105854 MH	R-5	Rural-5 Acre	Single Wide
96 108422 MH	R-5	Rural-5 Acre	Double Wide
96 108504 MH	R-5	Rural-5 Acre	Double Wide
96 108383 RK	R-5	Rural-5 Acre	Single Family Res-Combo
96 108392 RK	R-5	Rural-5 Acre	Single Family Res-Combo
96 109644 RK	R-5	Rural-5 Acre	Single Family Res-Combo
96 108448 RK	R-5	Rural-5 Acre	Single Family Res-Combo
96 105382 RK	R-5	Rural-5 Acre	Accessory Apt Detached-Combo
96 104145 RK	CITY	City	Single Family Res-Combo
96 109136 MH	R-5	Rural-5 Acre	Double Wide
96 103261 MH	NB	Neighborhood Business	MH Park-Double Wide
96 108570 MH	R-5	Rural-5 Acre	Double Wide
96 108813 MH	R-5	Rural-5 Acre	Double Wide
96 107731 RK	RRT-10	Rural Resource Transition-10	Single Family Res-Combo
96 109161 RK	R-5	Rural-5 Acre	Single Family Res-Combo
96 108420 RK	R-5	Rural-5 Acre	Single Family Res-Combo
96 109269 RK	R-5	Rural-5 Acre	Single Family Res-Combo
96 108971 MH	NB	Neighborhood Business	MH Park-Double Wide
96 104166 RK	CITY	City	Single Family Res-Combo
96 105905 RK	CITY	City	Duplex-Combo
96 106284 RK	R-5	Rural-5 Acre	Single Family Res-Combo
96 108974 RK	R-5	Rural-5 Acre	SFR-Basic
96 108734 MH	R-5	Rural-5 Acre	Double Wide
96 105358 RK	CITY	City	Single Family Res-Combo
96 109337 MH	R-5	Rural-5 Acre	Double Wide
96 109336 MH	R-5	Rural-5 Acre	Double Wide
96 109334 MH	R-5	Rural-5 Acre	Double Wide
96 108180 RK	R-5	Rural-5 Acre	SFR-Basic
96 108159 RK	R-5	Rural-5 Acre	Single Family Res-Combo
96 105680 RK	R-5	Rural-5 Acre	Single Family Res-Combo
96 105678 RK	R-5	Rural-5 Acre	Single Family Res-Combo
96 103820 RK	R-5	Rural-5 Acre	Single Family Res-Combo
96 105681 RK	R-5	Rural-5 Acre	Single Family Res-Combo
96 103818 RK	R-5	Rural-5 Acre	Single Family Res-Combo
96 108156 RK	R-5	Rural-5 Acre	Single Family Res-Combo
96 107702 RK	R-5	Rural-5 Acre	Single Family Res-Combo
96 109250 RK	R-5	Rural-5 Acre	Single Family Res-Combo
96 107254 MH	R-5	Rural-5 Acre	Triple Wide

Accessory Dwelling Units

Index # - File Name: 1.0022 - Single Family Dwellings Data\_Snohomish County.pdf

96 103298 RK	CITY	City	Single Family Res-Combo
96 107402 RK	CITY	City	SFR-Basic
96 107461 RK	CITY	City	SFR-Basic
96 107465 RK	CITY	City	SFR-Basic
96 105098 RK	CITY	City	Single Family Res-Combo
96 108057 RK	R-5	Rural-5 Acre	Single Family Res-Combo
96 108188 RK	R-5	Rural-5 Acre	Single Family Res-Combo
96 108135 RK	R-5	Rural-5 Acre	SFR-Basic
96 108136 RK	R-5	Rural-5 Acre	SFR-Basic
96 108134 RK	R-5	Rural-5 Acre	SFR-Basic
96 107069 RK	R-5	Rural-5 Acre	Single Family Res-Combo
96 106941 RK	R-5	Rural-5 Acre	Single Family Res-Combo
96 108985 RK	R-5	Rural-5 Acre	Single Family Res-Combo
96 107048 RK	R-5	Rural-5 Acre	Single Family Res-Combo
96 105532 RK	R-5	Rural-5 Acre	Single Family Res-Combo
96 108132 RK	R-5	Rural-5 Acre	SFR-Basic
96 107068 RK	R-5	Rural-5 Acre	Single Family Res-Combo
96 108360 RK	R-5	Rural-5 Acre	Single Family Res-Combo
96 107878 RK	R-5	Rural-5 Acre	SFR-Basic
96 106778 RK	R-5	Rural-5 Acre	Single Family Res-Combo
96 110458 RK	R-5	Rural-5 Acre	Single Family Res-Combo
96 107661 RK	R-5	Rural-5 Acre	Single Family Res-Combo
96 107651 RK	R-5	Rural-5 Acre	SFR-Basic
96 107657 RK	R-5	Rural-5 Acre	SFR-Basic
96 107341 RK	RRT-10	Rural Resource Transition-10	Single Family Res-Combo
96 107116 RK	R-5	Rural-5 Acre	Single Family Res-Combo
96 107970 RK	R-5	Rural-5 Acre	Single Family Res-Combo
96 107361 RK	F	Forestry	Single Family Res-Combo
96 109999 MH	CITY	City	Double Wide
96 107463 RK	R-5	Rural-5 Acre	Single Family Res-Combo
96 107623 RK	R-5	Rural-5 Acre	Single Family Res-Combo
96 107624 RK	R-5	Rural-5 Acre	Single Family Res-Combo
96 107478 MH	R-5	Rural-5 Acre	Double Wide
96 107606 MH	R-5	Rural-5 Acre	Double Wide
96 107613 MH	A-10	Agriculture-10 Acre	Double Wide
96 108426 RK	R-9,600	Residential 9,600 sq. ft.	SFR-Basic
96 108430 RK	R-9,600	Residential 9,600 sq. ft.	SFR-Basic
96 108297 RK	R-9,600	Residential 9,600 sq. ft.	SFR-Basic
96 108300 RK	R-9,600	Residential 9,600 sq. ft.	SFR-Basic
96 107633 RK	R-5	Rural-5 Acre	Single Family Res-Combo
96 107789 RK	R-5	Rural-5 Acre	Single Family Res-Combo
96 107791 MH	CITY	City	MH Park-Double Wide
96 107796 MH	R-5	Rural-5 Acre	Double Wide
96 107797 MH	NB	Neighborhood Business	Double Wide
96 107798 MH	NB	Neighborhood Business	Double Wide
96 104156 MH	NB	Neighborhood Business	MH Park-Double Wide
96 100615 MH	NB	Neighborhood Business	MH Park-Double Wide

Accessory Dwelling Units

Index # - File Name: 1.0022 - Single Family Dwellings Data\_Snohomish County.pdf

96 109402 MH	R-5	Rural-5 Acre	Double Wide
96 107865 RK	R-5	Rural-5 Acre	Single Family Res-Combo
96 106686 RK	R-5	Rural-5 Acre	Single Family Res-Combo
96 110352 MH	R-5	Rural-5 Acre	Single Wide
96 108421 RK	R-5	Rural-5 Acre	Single Family Res-Combo
96 109616 RK	R-5	Rural-5 Acre	Single Family Res-Combo
96 109443 MH	R-5	Rural-5 Acre	Double Wide
96 109160 RK	R-7,200	Residential 7,200 sq. ft.	SFR-Basic
96 109570 RK	R-7,200	Residential 7,200 sq. ft.	SFR-Basic
96 110313 RK	R-7,200	Residential 7,200 sq. ft.	SFR-Basic
96 107014 RK	R-7,200	Residential 7,200 sq. ft.	Single Family Res-Combo
96 107017 RK	R-7,200	Residential 7,200 sq. ft.	Single Family Res-Combo
96 110311 RK	R-7,200	Residential 7,200 sq. ft.	SFR-Basic
96 110312 RK	R-7,200	Residential 7,200 sq. ft.	SFR-Basic
96 110309 RK	R-7,200	Residential 7,200 sq. ft.	SFR-Basic
96 109162 RK	R-7,200	Residential 7,200 sq. ft.	SFR-Basic
96 107016 RK	R-7,200	Residential 7,200 sq. ft.	Single Family Res-Combo
96 106689 RK	R-9,600	Residential 9,600 sq. ft.	Single Family Res-Combo
96 108818 RK	R-9,600	Residential 9,600 sq. ft.	Single Family Res-Combo
96 109404 RK	R-9,600	Residential 9,600 sq. ft.	Single Family Res-Combo
96 109502 RK	R-9,600	Residential 9,600 sq. ft.	SFR-Basic
96 109511 RK	R-9,600	Residential 9,600 sq. ft.	SFR-Basic
96 108324 RK	R-9,600	Residential 9,600 sq. ft.	Single Family Res-Combo
96 109494 RK	R-9,600	Residential 9,600 sq. ft.	SFR-Basic
96 109503 RK	R-9,600	Residential 9,600 sq. ft.	SFR-Basic
96 109495 RK	R-9,600	Residential 9,600 sq. ft.	SFR-Basic
96 109512 RK	R-9,600	Residential 9,600 sq. ft.	SFR-Basic
96 109508 RK	R-9,600	Residential 9,600 sq. ft.	SFR-Basic
96 109514 RK	R-9,600	Residential 9,600 sq. ft.	SFR-Basic
96 109484 RK	R-9,600	Residential 9,600 sq. ft.	SFR-Basic
96 109509 RK	R-9,600	Residential 9,600 sq. ft.	SFR-Basic
96 109513 RK	R-9,600	Residential 9,600 sq. ft.	SFR-Basic
96 109480 RK	R-9,600	Residential 9,600 sq. ft.	SFR-Basic
96 109497 RK	R-9,600	Residential 9,600 sq. ft.	SFR-Basic
96 109515 RK	R-9,600	Residential 9,600 sq. ft.	SFR-Basic
96 108321 RK	R-9,600	Residential 9,600 sq. ft.	Single Family Res-Combo
96 109478 RK	R-9,600	Residential 9,600 sq. ft.	SFR-Basic
96 109491 RK	R-9,600	Residential 9,600 sq. ft.	SFR-Basic
96 109487 RK	R-9,600	Residential 9,600 sq. ft.	SFR-Basic
96 109501 RK	R-9,600	Residential 9,600 sq. ft.	SFR-Basic
96 109479 RK	R-9,600	Residential 9,600 sq. ft.	SFR-Basic
96 109500 RK	R-9,600	Residential 9,600 sq. ft.	SFR-Basic
96 108424 RK	R-9,600	Residential 9,600 sq. ft.	Single Family Res-Combo
96 108147 MH	R-5	Rural-5 Acre	Double Wide
96 109359 RK	R-5	Rural-5 Acre	Single Family Res-Combo
96 109633 RK	R-5	Rural-5 Acre	Single Family Res-Combo
96 109632 RK	R-9,600	Residential 9,600 sq. ft.	SFR-Basic

Accessory Dwelling Units

Index # - File Name: 1.0022 - Single Family Dwellings Data\_Snohomish County.pdf

96 107670 RK	R-9,600	Residential 9,600 sq. ft.	Single Family Res-Combo
96 108895 RK	R-9,600	Residential 9,600 sq. ft.	Single Family Res-Combo
96 110234 RK	R-9,600	Residential 9,600 sq. ft.	SFR-Basic
96 110591 RK	R-9,600	Residential 9,600 sq. ft.	SFR-Basic
96 110255 RK	R-9,600	Residential 9,600 sq. ft.	SFR-Basic
96 109133 RK	R-9,600	Residential 9,600 sq. ft.	Single Family Res-Combo
96 108894 RK	R-9,600	Residential 9,600 sq. ft.	Single Family Res-Combo
96 109346 RK	R-9,600	Residential 9,600 sq. ft.	Single Family Res-Combo
96 110567 RK	R-9,600	Residential 9,600 sq. ft.	SFR-Basic
96 107873 RK	PRD-7,200	Residential 7,200 sq. ft.	Single Family Res-Combo
96 109931 RK	PRD-7,200	Residential 7,200 sq. ft.	SFR-Basic
96 109934 RK	PRD-7,200	Residential 7,200 sq. ft.	SFR-Basic
96 109935 RK	PRD-7,200	Residential 7,200 sq. ft.	SFR-Basic
96 109936 RK	PRD-7,200	Residential 7,200 sq. ft.	SFR-Basic
96 109937 RK	PRD-7,200	Residential 7,200 sq. ft.	SFR-Basic
96 109938 RK	PRD-7,200	Residential 7,200 sq. ft.	SFR-Basic
96 109939 RK	PRD-7,200	Residential 7,200 sq. ft.	SFR-Basic
96 109941 RK	PRD-7,200	Residential 7,200 sq. ft.	SFR-Basic
96 109942 RK	PRD-7,200	Residential 7,200 sq. ft.	SFR-Basic
96 109944 RK	PRD-7,200	Residential 7,200 sq. ft.	SFR-Basic
96 109947 RK	PRD-7,200	Residential 7,200 sq. ft.	SFR-Basic
96 109948 RK	PRD-7,200	Residential 7,200 sq. ft.	SFR-Basic
96 109949 RK	PRD-7,200	Residential 7,200 sq. ft.	SFR-Basic
96 109951 RK	PRD-7,200	Residential 7,200 sq. ft.	SFR-Basic
96 109952 RK	PRD-7,200	Residential 7,200 sq. ft.	SFR-Basic
96 109954 RK	PRD-7,200	Residential 7,200 sq. ft.	SFR-Basic
96 109955 RK	PRD-7,200	Residential 7,200 sq. ft.	SFR-Basic
96 109957 RK	PRD-7,200	Residential 7,200 sq. ft.	SFR-Basic
96 109959 RK	PRD-7,200	Residential 7,200 sq. ft.	SFR-Basic
96 109961 MH	CITY	City	MH Park-Double Wide
96 110018 RK	R-8,400	Residential 8,400 sq. ft.	SFR-Basic
96 103775 RK	R-8,400	Residential 8,400 sq. ft.	Single Family Res-Combo
96 110254 RK	R-9,600	Residential 9,600 sq. ft.	SFR-Basic
96 110055 RK	A-10	Agriculture-10 Acre	Duplex-Combo
96 109780 RK	R-5	Rural-5 Acre	Single Family Res-Combo
96 109880 MH	CITY	City	MH Park-Double Wide
96 110144 RK	R-8,400	Residential 8,400 sq. ft.	SFR-Basic
96 107671 RK	R-8,400	Residential 8,400 sq. ft.	Single Family Res-Combo
96 108846 RK	R-8,400	Residential 8,400 sq. ft.	Single Family Res-Combo
96 110145 RK	R-8,400	Residential 8,400 sq. ft.	SFR-Basic
96 110391 RK	R-8,400	Residential 8,400 sq. ft.	Duplex-Combo
96 110302 MH	NB	Neighborhood Business	MH Park-Double Wide
96 109388 RK	R-5	Rural-5 Acre	Single Family Res-Combo
96 104473 RK	R-5	Rural-5 Acre	Single Family Res-Combo
96 110516 MH	R-5	Rural-5 Acre	Double Wide
96 103664 MH	R-5	Rural-5 Acre	Double Wide
96 101145 RK	R-5	Rural-5 Acre	Single Family Res-Combo

Accessory Dwelling Units

Index # - File Name: 1.0022 - Single Family Dwellings Data\_Snohomish County.pdf

95 110932 RK	F	Forestry	Single Family Res-Combo
96 106949 RK	R-9,600	Residential 9,600 sq. ft.	SFR-Basic
96 106950 RK	R-9,600	Residential 9,600 sq. ft.	SFR-Basic
96 108930 RK	R-9,600	Residential 9,600 sq. ft.	Single Family Res-Combo
96 102304 RK	R-9,600	Residential 9,600 sq. ft.	Single Family Res-Combo
96 102302 RK	R-9,600	Residential 9,600 sq. ft.	Single Family Res-Combo
96 100610 RK	R-9,600	Residential 9,600 sq. ft.	Single Family Res-Combo
96 108070 RK	R-9,600	Residential 9,600 sq. ft.	SFR-Basic
96 108049 RK	R-9,600	Residential 9,600 sq. ft.	SFR-Basic
96 108047 RK	R-9,600	Residential 9,600 sq. ft.	SFR-Basic
96 100267 RK	R-9,600	Residential 9,600 sq. ft.	Single Family Res-Combo
96 106946 RK	R-9,600	Residential 9,600 sq. ft.	SFR-Basic
96 106943 RK	R-9,600	Residential 9,600 sq. ft.	Single Family Res-Combo
96 102161 RK	R-5	Rural-5 Acre	Single Family Res-Combo
96 100339 RK	R-5	Rural-5 Acre	Single Family Res-Combo
95 110806 RK	MR	Multiple Residential	Duplex-Combo
95 110821 RK	R-5	Rural-5 Acre	Single Family Res-Combo
96 102926 RK	R-5	Rural-5 Acre	Single Family Res-Combo
95 110710 RK	R-5	Rural-5 Acre	Single Family Res-Combo
95 110846 RK	R-5	Rural-5 Acre	Single Family Res-Combo
96 108081 RK	CITY	City	SFR-Basic
96 110242 RK	CITY	City	SFR-Basic
96 110229 RK	CITY	City	SFR-Basic
96 110228 RK	CITY	City	SFR-Basic
96 110243 RK	CITY	City	SFR-Basic
96 107149 RK	CITY	City	SFR-Basic
96 107148 RK	CITY	City	SFR-Basic
96 105226 RK	CITY	City	SFR-Basic
96 105227 RK	CITY	City	SFR-Basic
96 106408 RK	CITY	City	SFR-Basic
96 105229 RK	CITY	City	SFR-Basic
96 102458 RK	CITY	City	SFR-Basic
96 103972 RK	CITY	City	SFR-Basic
96 103969 RK	CITY	City	SFR-Basic
96 101537 RK	CITY	City	SFR-Basic
96 102451 RK	CITY	City	SFR-Basic
96 105231 RK	CITY	City	SFR-Basic
96 103458 RK	CITY	City	SFR-Basic
96 105232 RK	CITY	City	SFR-Basic
96 103976 RK	CITY	City	SFR-Basic
96 105233 RK	CITY	City	SFR-Basic
96 106409 RK	CITY	City	SFR-Basic
96 106410 RK	CITY	City	SFR-Basic
96 103705 RK	CITY	City	Single Family Res-Combo
96 103459 RK	CITY	City	SFR-Basic
95 109397 RK	CITY	City	Single Family Res-Combo
95 110714 RK	CITY	City	Single Family Res-Combo

Accessory Dwelling Units

Index # - File Name: 1.0022 - Single Family Dwellings Data\_Snohomish County.pdf

96 108072 RK	CITY	City	SFR-Basic
96 103980 RK	CITY	City	SFR-Basic
96 103460 RK	CITY	City	SFR-Basic
95 109157 RK	CITY	City	Single Family Res-Combo
96 100427 RK	CITY	City	SFR-Basic
95 109155 RK	CITY	City	Single Family Res-Combo
96 103974 RK	CITY	City	SFR-Basic
96 107147 RK	CITY	City	SFR-Basic
96 108080 RK	CITY	City	SFR-Basic
96 107146 RK	CITY	City	SFR-Basic
96 108068 RK	CITY	City	SFR-Basic
96 107145 RK	CITY	City	SFR-Basic
96 108079 RK	CITY	City	SFR-Basic
96 106411 RK	CITY	City	SFR-Basic
96 108075 RK	CITY	City	SFR-Basic
96 108069 RK	CITY	City	SFR-Basic
96 110238 RK	CITY	City	SFR-Basic
96 110239 RK	CITY	City	SFR-Basic
96 110244 RK	CITY	City	SFR-Basic
96 110240 RK	CITY	City	SFR-Basic
96 109579 RK	CITY	City	SFR-Basic
96 107926 RK	CITY	City	SFR-Basic
96 107169 RK	CITY	City	SFR-Basic
96 103462 RK	CITY	City	Single Family Res-Combo
96 100607 RK	R-9,600	Residential 9,600 sq. ft.	Single Family Res-Combo
96 100611 RK	R-9,600	Residential 9,600 sq. ft.	Single Family Res-Combo
96 100609 RK	R-9,600	Residential 9,600 sq. ft.	Single Family Res-Combo
96 106172 MH	R-5	Rural-5 Acre	Double Wide
96 100256 MH	R-5	Rural-5 Acre	Single Wide
96 102058 MH	F	Forestry	Double Wide
96 103725 RK	R-5	Rural-5 Acre	Single Family Res-Combo
96 108100 RK	R-5	Rural-5 Acre	Single Family Res-Combo
96 104676 RK	R-5	Rural-5 Acre	Single Family Res-Combo
96 106178 RK	R-5	Rural-5 Acre	Single Family Res-Combo
96 108298 MH	R-5	Rural-5 Acre	Triple Wide
96 100330 RK	R-9,600	Residential 9,600 sq. ft.	Single Family Res-Combo
96 100340 MH	CITY	City	MH Park-Double Wide
96 101858 RK	R-8,400	Residential 8,400 sq. ft.	Single Family Res-Combo
96 105015 RK	R-5	Rural-5 Acre	Duplex-Combo
96 100580 RK	R-5	Rural-5 Acre	Single Family Res-Combo
96 108605 RK	PRD-LDMR	Low Density Multiple Reside	SFR-Basic
96 108606 RK	PRD-LDMR	Low Density Multiple Reside	SFR-Basic
96 108607 RK	PRD-LDMR	Low Density Multiple Reside	SFR-Basic
96 108608 RK	PRD-LDMR	Low Density Multiple Reside	SFR-Basic
96 108609 RK	PRD-LDMR	Low Density Multiple Reside	SFR-Basic
96 108610 RK	PRD-LDMR	Low Density Multiple Reside	SFR-Basic
96 106388 RK	PRD-LDMR	Low Density Multiple Reside	SFR-Basic

Accessory Dwelling Units

Index # - File Name: 1.0022 - Single Family Dwellings Data\_Snohomish County.pdf

96 106387 RK	PRD-LDMR	Low Density Multiple Reside	SFR-Basic
96 106389 RK	PRD-LDMR	Low Density Multiple Reside	SFR-Basic
96 106390 RK	PRD-LDMR	Low Density Multiple Reside	SFR-Basic
96 106395 RK	PRD-LDMR	Low Density Multiple Reside	SFR-Basic
96 106391 RK	PRD-LDMR	Low Density Multiple Reside	SFR-Basic
96 106392 RK	PRD-LDMR	Low Density Multiple Reside	SFR-Basic
96 106394 RK	PRD-LDMR	Low Density Multiple Reside	SFR-Basic
96 105113 RK	PRD-LDMR	Low Density Multiple Reside	SFR-Basic
96 104406 RK	PRD-LDMR	Low Density Multiple Reside	SFR-Basic
96 102080 RK	PRD-LDMR	Low Density Multiple Reside	Single Family Res-Combo
96 102079 RK	PRD-LDMR	Low Density Multiple Reside	Single Family Res-Combo
96 106871 MH	LDMR	Low Density Multiple Reside	Double Wide
96 100834 RK	CITY	City	Duplex-Combo
96 105457 RK	R-9,600	Residential 9,600 sq. ft.	Duplex-Combo
96 104317 MH	R-5	Rural-5 Acre	Double Wide
96 102893 RK	R-5	Rural-5 Acre	Single Family Res-Combo
96 100681 MH	SA-1	Suburban Agriculture-1 Acre	Double Wide
96 100933 RK	MR	Multiple Residential	Single Family Res-Combo
96 100937 RK	R-5	Rural-5 Acre	Single Family Res-Combo
96 101092 RK	R-5	Rural-5 Acre	Single Family Res-Combo
96 104230 RK	R-5	Rural-5 Acre	Single Family Res-Combo
96 101759 MH	R-5	Rural-5 Acre	Single Wide
96 101134 RK	F	Forestry	Single Family Res-Combo
96 101136 MH	CITY	City	MH Park-Double Wide
96 104872 RK	R-5	Rural-5 Acre	Single Family Res-Combo
96 101161 RK	R-5	Rural-5 Acre	Single Family Res-Combo
96 101173 MH	NB	Neighborhood Business	MH Park-Double Wide
96 101231 RK	R-5	Rural-5 Acre	Single Family Res-Combo
96 101353 MH	R-5	Rural-5 Acre	Double Wide
96 101343 MH	A-10 : R-5	Agriculture-10 Acre : Rural-5	Double Wide
96 102191 MH	A-10 : CITY	Agriculture-10 Acre : City	Triple Wide
96 101542 RK	R-5	Rural-5 Acre	Single Family Res-Combo
96 102081 RK	R-9,600	Residential 9,600 sq. ft.	Single Family Res-Combo
96 108858 RK	CITY	City	SFR-Basic
96 109385 RK	CITY	City	SFR-Basic
96 108793 RK	CITY	City	SFR-Basic
96 106146 RK	CITY	City	SFR-Basic
96 101054 RK	CITY	City	Single Family Res-Combo
96 102638 RK	CITY	City	Single Family Res-Combo
96 102312 RK	CITY	City	Single Family Res-Combo
96 110252 RK	CITY	City	SFR-Basic
96 106102 RK	CITY	City	SFR-Basic
96 107597 RK	CITY	City	SFR-Basic
96 102419 RK	CITY	City	SFR-Basic
96 109194 RK	CITY	City	Single Family Res-Combo
96 107273 RK	CITY	City	SFR-Basic
96 101056 RK	CITY	City	Single Family Res-Combo



Accessory Dwelling Units

Index # - File Name: 1.0022 - Single Family Dwellings Data\_Snohomish County.pdf

96 102311 RK	CITY	City	Single Family Res-Combo
96 106673 RK	CITY	City	Single Family Res-Combo
96 110392 RK	CITY	City	SFR-Basic
96 103441 RK	CITY	City	SFR-Basic
96 109849 RK	CITY	City	SFR-Basic
96 108856 RK	CITY	City	SFR-Basic
96 108794 RK	CITY	City	SFR-Basic
96 108503 RK	CITY	City	SFR-Basic
96 108500 RK	CITY	City	SFR-Basic
96 107274 RK	CITY	City	SFR-Basic
96 106105 RK	CITY	City	SFR-Basic
96 106836 RK	CITY	City	SFR-Basic
96 101058 RK	CITY	City	Single Family Res-Combo
96 109722 RK	CITY	City	SFR-Basic
96 103151 RK	CITY	City	SFR-Basic
96 106106 RK	CITY	City	SFR-Basic
96 107095 RK	CITY	City	SFR-Basic
96 109386 RK	CITY	City	SFR-Basic
96 109291 RK	CITY	City	SFR-Basic
96 103153 RK	CITY	City	SFR-Basic
96 109387 RK	CITY	City	Single Family Res-Combo
96 103804 RK	CITY	City	SFR-Basic
96 106674 RK	CITY	City	Single Family Res-Combo
96 106676 RK	CITY	City	SFR-Basic
96 106361 RK	CITY	City	Single Family Res-Combo
96 102748 MH	RRT-10	Rural Resource Transition-10	Double Wide
96 101418 RK	R-7,200	Residential 7,200 sq. ft.	Single Family Res-Combo
96 101444 RK	F	Forestry	Single Family Res-Combo
96 101454 RK	CITY	City	Duplex-Combo
96 104376 MH	R-5	Rural-5 Acre	Triple Wide
96 100850 RK	CITY	City	Single Family Res-Combo
96 105339 RK	PRD-9,600	Residential 9,600 sq. ft.	SFR-Basic
96 105340 RK	PRD-9,600	Residential 9,600 sq. ft.	SFR-Basic
96 109110 RK	PRD-9,600	Residential 9,600 sq. ft.	SFR-Basic
96 101629 RK	PRD-9,600	Residential 9,600 sq. ft.	SFR-Basic
96 101627 RK	PRD-9,600	Residential 9,600 sq. ft.	SFR-Basic
96 104793 RK	PRD-9,600	Residential 9,600 sq. ft.	Single Family Res-Combo
96 104797 RK	PRD-9,600	Residential 9,600 sq. ft.	Single Family Res-Combo
96 104799 RK	PRD-9,600	Residential 9,600 sq. ft.	Single Family Res-Combo
96 104798 RK	PRD-9,600	Residential 9,600 sq. ft.	Single Family Res-Combo
96 107931 RK	PRD-9,600	Residential 9,600 sq. ft.	Single Family Res-Combo
96 101771 RK	PRD-9,600	Residential 9,600 sq. ft.	Single Family Res-Combo
96 101415 MH	MHP	Mobile Home Park	MH Park-Single Wide
96 104199 RK	PRD-9,600	Residential 9,600 sq. ft.	Single Family Res-Combo
96 102007 RK	PRD-9,600	Residential 9,600 sq. ft.	Single Family Res-Combo
96 105344 RK	PRD-9,600	Residential 9,600 sq. ft.	Single Family Res-Combo
96 106628 RK	PRD-9,600	Residential 9,600 sq. ft.	SFR-Basic

Accessory Dwelling Units

Index # - File Name: 1.0022 - Single Family Dwellings Data\_Snohomish County.pdf

96 110200 RK	PRD-9,600	Residential 9,600 sq. ft.	Single Family Res-Combo
96 104446 RK	R-8,400	Residential 8,400 sq. ft.	SFR-Basic
96 104440 RK	R-8,400	Residential 8,400 sq. ft.	SFR-Basic
96 105567 RK	R-8,400	Residential 8,400 sq. ft.	SFR-Basic
96 104453 RK	R-8,400	Residential 8,400 sq. ft.	SFR-Basic
96 104458 RK	R-8,400	Residential 8,400 sq. ft.	SFR-Basic
96 104460 RK	R-8,400	Residential 8,400 sq. ft.	SFR-Basic
96 104443 RK	R-8,400	Residential 8,400 sq. ft.	SFR-Basic
96 104439 RK	R-8,400	Residential 8,400 sq. ft.	SFR-Basic
96 104444 RK	R-8,400	Residential 8,400 sq. ft.	SFR-Basic
96 104454 RK	R-8,400	Residential 8,400 sq. ft.	SFR-Basic
96 104760 RK	R-8,400	Residential 8,400 sq. ft.	Single Family Res-Combo
96 104435 RK	R-8,400	Residential 8,400 sq. ft.	SFR-Basic
96 105037 RK	R-8,400	Residential 8,400 sq. ft.	SFR-Basic
96 105564 RK	R-8,400	Residential 8,400 sq. ft.	SFR-Basic
96 105124 RK	R-8,400	Residential 8,400 sq. ft.	SFR-Basic
96 104455 RK	R-8,400	Residential 8,400 sq. ft.	SFR-Basic
96 105194 RK	R-8,400	Residential 8,400 sq. ft.	Single Family Res-Combo
96 105980 RK	R-8,400	Residential 8,400 sq. ft.	SFR-Basic
96 104756 RK	R-8,400	Residential 8,400 sq. ft.	SFR-Basic
96 105981 RK	R-8,400	Residential 8,400 sq. ft.	SFR-Basic
96 105563 RK	R-8,400	Residential 8,400 sq. ft.	SFR-Basic
96 105038 RK	R-8,400	Residential 8,400 sq. ft.	SFR-Basic
96 104752 RK	R-8,400	Residential 8,400 sq. ft.	SFR-Basic
96 104755 RK	R-8,400	Residential 8,400 sq. ft.	SFR-Basic
96 104447 RK	R-8,400	Residential 8,400 sq. ft.	SFR-Basic
96 104761 RK	R-8,400	Residential 8,400 sq. ft.	Single Family Res-Combo
96 104442 RK	R-8,400	Residential 8,400 sq. ft.	SFR-Basic
96 104448 RK	R-8,400	Residential 8,400 sq. ft.	SFR-Basic
96 104465 RK	R-8,400	Residential 8,400 sq. ft.	SFR-Basic
96 104449 RK	R-8,400	Residential 8,400 sq. ft.	SFR-Basic
96 104464 RK	R-8,400	Residential 8,400 sq. ft.	SFR-Basic
96 105387 RK	R-8,400	Residential 8,400 sq. ft.	SFR-Basic
96 104469 RK	R-8,400	Residential 8,400 sq. ft.	SFR-Basic
96 104461 RK	R-8,400	Residential 8,400 sq. ft.	SFR-Basic
96 109154 RK	R-8,400	Residential 8,400 sq. ft.	Single Family Res-Combo
96 109152 RK	R-8,400	Residential 8,400 sq. ft.	Single Family Res-Combo
96 109149 RK	R-8,400	Residential 8,400 sq. ft.	Single Family Res-Combo
96 102160 RK	R-5	Rural-5 Acre	Single Family Res-Combo
96 109793 RK	R-5	Rural-5 Acre	Single Family Res-Combo
96 109790 RK	R-5	Rural-5 Acre	Single Family Res-Combo
95 110555 RK	R-5	Rural-5 Acre	Single Family Res-Combo
95 110726 RK	CITY	City	Single Family Res-Combo
96 102845 RK	CITY	City	Single Family Res-Combo
96 102843 RK	CITY	City	Single Family Res-Combo
96 108645 RK	R-5	Rural-5 Acre	Single Family Res-Combo
96 103834 RK	R-5	Rural-5 Acre	Single Family Res-Combo

Accessory Dwelling Units

Index # - File Name: 1.0022 - Single Family Dwellings Data\_Snohomish County.pdf

96 100016 MH	NB	Neighborhood Business	MH Park-Double Wide
96 100310 MH	R-5	Rural-5 Acre	Double Wide
96 101186 RK	CITY	City	SFR-Basic
96 101268 RK	CITY	City	SFR-Basic
96 101271 RK	CITY	City	SFR-Basic
95 110379 RK	CITY	City	Single Family Res-Combo
96 105975 RK	CITY	City	SFR-Basic
96 103979 RK	CITY	City	SFR-Basic
96 103891 RK	CITY	City	SFR-Basic
96 103892 RK	CITY	City	SFR-Basic
96 103516 RK	CITY	City	SFR-Basic
96 105132 RK	CITY	City	SFR-Basic
96 104163 RK	CITY	City	SFR-Basic
96 103321 RK	CITY	City	SFR-Basic
96 103017 RK	CITY	City	SFR-Basic
96 105253 RK	CITY	City	SFR-Basic
96 107008 RK	CITY	City	SFR-Basic
96 105130 RK	CITY	City	SFR-Basic
95 110230 RK	CITY	City	Single Family Res-Combo
96 104420 RK	CITY	City	SFR-Basic
95 109398 RK	CITY	City	Single Family Res-Combo
96 100316 RK	CITY	City	Single Family Res-Combo
96 103012 RK	CITY	City	SFR-Basic
96 103011 RK	CITY	City	SFR-Basic
96 105139 RK	CITY	City	SFR-Basic
96 103013 RK	CITY	City	SFR-Basic
96 102107 RK	CITY	City	SFR-Basic
96 105641 RK	CITY	City	SFR-Basic
96 100428 RK	CITY	City	Single Family Res-Combo
96 101534 RK	CITY	City	SFR-Basic
96 103977 RK	CITY	City	SFR-Basic
96 105141 RK	CITY	City	SFR-Basic
96 106412 RK	CITY	City	SFR-Basic
96 106649 RK	CITY	City	Single Family Res-Combo
95 110226 RK	CITY	City	Single Family Res-Combo
96 106507 RK	CITY	City	SFR-Basic
95 110196 RK	CITY	City	Single Family Res-Combo
96 107007 RK	CITY	City	SFR-Basic
96 106646 RK	CITY	City	SFR-Basic
96 106811 RK	CITY	City	SFR-Basic
96 106508 RK	CITY	City	SFR-Basic
96 103323 RK	CITY	City	SFR-Basic
96 106641 RK	CITY	City	SFR-Basic
96 103518 RK	CITY	City	SFR-Basic
96 106809 RK	CITY	City	SFR-Basic
96 103984 RK	CITY	City	SFR-Basic
96 102968 RK	CITY	City	SFR-Basic

Accessory Dwelling Units

Index # - File Name: 1.0022 - Single Family Dwellings Data\_Snohomish County.pdf

96 102971 RK	CITY	City	SFR-Basic
96 102422 RK	CITY	City	SFR-Basic
96 107480 RK	CITY	City	SFR-Basic
96 107475 RK	CITY	City	SFR-Basic
96 107857 RK	CITY	City	SFR-Basic
96 107858 RK	CITY	City	SFR-Basic
96 103468 RK	CITY	City	SFR-Basic
96 107856 RK	CITY	City	SFR-Basic
96 103465 RK	CITY	City	SFR-Basic
96 103467 RK	CITY	City	SFR-Basic
96 103469 RK	CITY	City	SFR-Basic
96 103472 RK	CITY	City	SFR-Basic
96 103473 RK	CITY	City	SFR-Basic
96 100589 RK	R-9,600	Residential 9,600 sq. ft.	Single Family Res-Combo
96 100892 RK	R-9,600	Residential 9,600 sq. ft.	Single Family Res-Combo
96 100588 RK	R-9,600	Residential 9,600 sq. ft.	Single Family Res-Combo
96 100904 RK	R-9,600	Residential 9,600 sq. ft.	Single Family Res-Combo
96 104637 RK	CITY	City	SFR-Basic
95 110663 RK	CITY	City	SFR-Basic
95 110392 RK	CITY	City	Single Family Res-Combo
95 110823 RK	CITY	City	Single Family Res-Combo
95 108027 RK	CITY	City	Single Family Res-Combo
95 108030 RK	CITY	City	Single Family Res-Combo
95 110193 RK	R-5	Rural-5 Acre	Single Family Res-Combo
96 101676 RK	CITY	City	Single Family Res-Combo
96 108754 RK	CITY	City	SFR-Basic
96 104290 RK	CITY	City	SFR-Basic
96 104883 RK	CITY	City	SFR-Basic
96 104885 RK	CITY	City	SFR-Basic
96 104293 RK	CITY	City	SFR-Basic
96 104289 RK	CITY	City	SFR-Basic
96 104292 RK	CITY	City	SFR-Basic
96 110291 RK	CITY	City	SFR-Basic
96 108752 RK	CITY	City	SFR-Basic
96 110292 RK	CITY	City	SFR-Basic
96 110294 RK	CITY	City	SFR-Basic
96 110295 RK	CITY	City	SFR-Basic
96 104886 RK	CITY	City	SFR-Basic
96 104888 RK	CITY	City	SFR-Basic
96 100369 RK	CITY	City	Single Family Res-Combo
96 106593 RK	CITY	City	SFR-Basic
96 106592 RK	CITY	City	SFR-Basic
96 106594 RK	CITY	City	SFR-Basic
95 110397 MH	CITY	City	Double Wide
96 107855 RK	CITY	City	SFR-Basic
96 104345 RK	CITY	City	SFR-Basic
96 104349 RK	CITY	City	SFR-Basic

Accessory Dwelling Units

Index # - File Name: 1.0022 - Single Family Dwellings Data\_Snohomish County.pdf

96 104344 RK	CITY	City	SFR-Basic
96 104347 RK	CITY	City	SFR-Basic
96 104346 RK	CITY	City	SFR-Basic
96 104348 RK	CITY	City	SFR-Basic
96 104343 RK	CITY	City	SFR-Basic
96 103727 RK	CITY	City	SFR-Basic
96 106492 RK	CITY	City	SFR-Basic
96 106495 RK	CITY	City	SFR-Basic
96 104575 RK	CITY	City	SFR-Basic
96 105052 RK	CITY	City	SFR-Basic
96 106491 RK	CITY	City	SFR-Basic
96 105053 RK	CITY	City	SFR-Basic
95 108960 RK	CITY	City	Single Family Res-Combo
95 110383 RK	RRT-10	Rural Resource Transition-10	Single Family Res-Combo
96 101523 RK	R-5	Rural-5 Acre	Single Family Res-Combo
96 104256 MH	F	Forestry	Double Wide
96 102814 MH	R-5	Rural-5 Acre	Single Wide
95 109522 RK	CITY	City	Duplex-Combo
95 109523 RK	CITY	City	Duplex-Combo
96 100010 RK	R-5	Rural-5 Acre	Single Family Res-Combo
96 102740 RK	R-5	Rural-5 Acre	Single Family Res-Combo
96 108549 RK	R-5	Rural-5 Acre	Single Family Res-Combo
95 109720 RK	R-5	Rural-5 Acre	Single Family Res-Combo
95 109358 RK	R-9,600	Residential 9,600 sq. ft.	Single Family Res-Combo
95 109371 MH	R-5	Rural-5 Acre	Single Wide
95 110135 RK	PRD-9,600	Residential 9,600 sq. ft.	Single Family Res-Combo
96 105890 RK	PRD-9,600	Residential 9,600 sq. ft.	SFR-Basic
95 110133 RK	PRD-9,600	Residential 9,600 sq. ft.	Single Family Res-Combo
95 110635 RK	PRD-9,600	Residential 9,600 sq. ft.	Single Family Res-Combo
96 104311 RK	PRD-9,600	Residential 9,600 sq. ft.	SFR-Basic
96 105892 RK	PRD-9,600	Residential 9,600 sq. ft.	SFR-Basic
96 107288 RK	PRD-9,600	Residential 9,600 sq. ft.	Single Family Res-Combo
96 107290 RK	PRD-9,600	Residential 9,600 sq. ft.	SFR-Basic
96 104902 RK	PRD-9,600	Residential 9,600 sq. ft.	SFR-Basic
96 104898 RK	PRD-9,600	Residential 9,600 sq. ft.	SFR-Basic
96 104308 RK	PRD-9,600	Residential 9,600 sq. ft.	SFR-Basic
96 105170 RK	PRD-9,600	Residential 9,600 sq. ft.	SFR-Basic
96 104310 RK	PRD-9,600	Residential 9,600 sq. ft.	SFR-Basic
96 105171 RK	PRD-9,600	Residential 9,600 sq. ft.	SFR-Basic
96 103025 RK	PRD-9,600	Residential 9,600 sq. ft.	SFR-Basic
96 103028 RK	PRD-9,600	Residential 9,600 sq. ft.	SFR-Basic
96 102900 RK	PRD-9,600	Residential 9,600 sq. ft.	SFR-Basic
96 102912 RK	PRD-9,600	Residential 9,600 sq. ft.	SFR-Basic
96 100052 RK	PRD-9,600	Residential 9,600 sq. ft.	Single Family Res-Combo
96 110073 RK	PRD-9,600	Residential 9,600 sq. ft.	SFR-Basic
96 106233 RK	PRD-9,600	Residential 9,600 sq. ft.	SFR-Basic
96 110074 RK	PRD-9,600	Residential 9,600 sq. ft.	SFR-Basic

Accessory Dwelling Units

Index # - File Name: 1.0022 - Single Family Dwellings Data\_Snohomish County.pdf

96 101248 RK	PRD-9,600	Residential 9,600 sq. ft.	Single Family Res-Combo
96 110075 RK	PRD-9,600	Residential 9,600 sq. ft.	SFR-Basic
96 104390 RK	PRD-9,600	Residential 9,600 sq. ft.	SFR-Basic
96 110076 RK	PRD-9,600	Residential 9,600 sq. ft.	SFR-Basic
96 102230 RK	PRD-9,600	Residential 9,600 sq. ft.	Single Family Res-Combo
96 101158 RK	PRD-9,600	Residential 9,600 sq. ft.	Single Family Res-Combo
96 102232 RK	PRD-9,600	Residential 9,600 sq. ft.	Single Family Res-Combo
96 102992 RK	PRD-9,600	Residential 9,600 sq. ft.	SFR-Basic
96 102985 RK	PRD-9,600	Residential 9,600 sq. ft.	SFR-Basic
96 102227 RK	PRD-9,600	Residential 9,600 sq. ft.	Single Family Res-Combo
96 103504 RK	PRD-9,600	Residential 9,600 sq. ft.	SFR-Basic
96 104715 RK	PRD-9,600	Residential 9,600 sq. ft.	SFR-Basic
96 105288 RK	PRD-9,600	Residential 9,600 sq. ft.	SFR-Basic
96 106235 RK	PRD-9,600	Residential 9,600 sq. ft.	SFR-Basic
96 106236 RK	PRD-9,600	Residential 9,600 sq. ft.	SFR-Basic
96 104713 RK	PRD-9,600	Residential 9,600 sq. ft.	SFR-Basic
96 110077 RK	PRD-9,600	Residential 9,600 sq. ft.	SFR-Basic
96 107625 RK	PRD-9,600	Residential 9,600 sq. ft.	SFR-Basic
96 101155 RK	PRD-9,600	Residential 9,600 sq. ft.	Single Family Res-Combo
95 107088 RK	PRD-9,600	Residential 9,600 sq. ft.	Single Family Res-Combo
96 103929 RK	PRD-9,600	Residential 9,600 sq. ft.	SFR-Basic
96 101381 RK	PRD-9,600	Residential 9,600 sq. ft.	Single Family Res-Combo
96 104812 RK	PRD-9,600	Residential 9,600 sq. ft.	SFR-Basic
96 103932 RK	PRD-9,600	Residential 9,600 sq. ft.	SFR-Basic
96 102989 RK	PRD-9,600	Residential 9,600 sq. ft.	SFR-Basic
96 106237 RK	PRD-9,600	Residential 9,600 sq. ft.	SFR-Basic
96 102882 RK	PRD-9,600	Residential 9,600 sq. ft.	SFR-Basic
96 105289 RK	PRD-9,600	Residential 9,600 sq. ft.	SFR-Basic
96 104720 RK	PRD-9,600	Residential 9,600 sq. ft.	SFR-Basic
96 102988 RK	PRD-9,600	Residential 9,600 sq. ft.	Single Family Res-Combo
96 107166 RK	PRD-9,600	Residential 9,600 sq. ft.	SFR-Basic
96 104719 RK	PRD-9,600	Residential 9,600 sq. ft.	SFR-Basic
96 104717 RK	PRD-9,600	Residential 9,600 sq. ft.	Single Family Res-Combo
96 102417 RK	PRD-9,600	Residential 9,600 sq. ft.	SFR-Basic
96 102003 RK	PRD-9,600	Residential 9,600 sq. ft.	SFR-Basic
96 102004 RK	PRD-9,600	Residential 9,600 sq. ft.	SFR-Basic
96 102130 RK	PRD-9,600	Residential 9,600 sq. ft.	Single Family Res-Combo
96 102317 RK	PRD-9,600	Residential 9,600 sq. ft.	Single Family Res-Combo
96 101986 RK	PRD-9,600	Residential 9,600 sq. ft.	SFR-Basic
96 102316 RK	PRD-9,600	Residential 9,600 sq. ft.	SFR-Basic
96 102313 RK	PRD-9,600	Residential 9,600 sq. ft.	SFR-Basic
96 103143 RK	PRD-9,600	Residential 9,600 sq. ft.	SFR-Basic
96 103142 RK	PRD-9,600	Residential 9,600 sq. ft.	Single Family Res-Combo
95 109825 MH	F	Forestry	Double Wide
96 102212 MH	R-5	Rural-5 Acre	Double Wide
96 101242 MH	R-5	Rural-5 Acre	Double Wide
96 102263 MH	R-5	Rural-5 Acre	Double Wide

Accessory Dwelling Units

Index # - File Name: 1.0022 - Single Family Dwellings Data\_Snohomish County.pdf

96 105116 MH	CITY	City	MH Park-Double Wide
96 104641 MH	R-5	Rural-5 Acre	Single Wide
96 106393 RK	F	Forestry	Single Family Res-Combo
96 103555 RK	R-5	Rural-5 Acre	SFR-Basic
96 103556 RK	R-5	Rural-5 Acre	SFR-Basic
96 105545 RK	R-5	Rural-5 Acre	SFR-Basic
96 103339 RK	R-5	Rural-5 Acre	Single Family Res-Combo
96 103365 RK	R-5	Rural-5 Acre	Single Family Res-Combo
96 103139 MH	A-10 : R-5	Agriculture-10 Acre : Rural-5	Double Wide
96 103175 RK	F	Forestry	Single Family Res-Combo
96 103601 MH	NB	Neighborhood Business	MH Park-Single Wide
96 103491 RK	R-5	Rural-5 Acre	Single Family Res-Combo
96 103548 RK	R-5	Rural-5 Acre	Single Family Res-Combo
96 103576 RK	R-5	Rural-5 Acre	Single Family Res-Combo
96 103617 RK	R-5	Rural-5 Acre	Single Family Res-Combo
96 106662 RK	R-5	Rural-5 Acre	Single Family Res-Combo
96 103626 RK	R-5	Rural-5 Acre	Single Family Res-Combo
96 107604 RK	CITY	City	Duplex-Combo
96 103753 RK	R-5	Rural-5 Acre	Single Family Res-Combo
96 103788 MH	R-5	Rural-5 Acre	Double Wide
96 103809 MH	NB	Neighborhood Business	MH Park-Double Wide
96 103815 MH	R-5	Rural-5 Acre	Triple Wide
96 105780 RK	R-5	Rural-5 Acre	Single Family Res-Combo
96 103828 RK	R-5	Rural-5 Acre	Single Family Res-Combo
95 110616 RK	CITY	City	Single Family Res-Combo
95 110614 RK	CITY	City	Single Family Res-Combo
95 110617 RK	CITY	City	Single Family Res-Combo
95 110615 RK	CITY	City	Single Family Res-Combo
96 105147 RK	CITY	City	Single Family Res-Combo
96 110172 RK	CITY	City	Single Family Res-Combo
96 110177 RK	CITY	City	Single Family Res-Combo
96 105149 RK	CITY	City	Single Family Res-Combo
95 110619 RK	CITY	City	Single Family Res-Combo
96 105151 RK	CITY	City	Single Family Res-Combo
96 105152 RK	CITY	City	Single Family Res-Combo
96 105154 RK	CITY	City	Single Family Res-Combo
96 105155 RK	CITY	City	Single Family Res-Combo
96 105156 RK	CITY	City	Single Family Res-Combo
96 102816 RK	UC	Urban Center	Duplex-Combo
96 102668 RK	PRD-LDMR	Low Density Multiple Reside	Single Family Res-Combo
96 102667 RK	PRD-LDMR	Low Density Multiple Reside	Single Family Res-Combo
96 102797 RK	PRD-LDMR	Low Density Multiple Reside	Single Family Res-Combo
96 102798 RK	PRD-LDMR	Low Density Multiple Reside	Single Family Res-Combo
95 109445 RK	PRD-LDMR	Low Density Multiple Reside	Single Family Res-Combo
96 103081 RK	PRD-LDMR	Low Density Multiple Reside	SFR-Basic
96 102945 RK	PRD-LDMR	Low Density Multiple Reside	SFR-Basic
96 102948 RK	PRD-LDMR	Low Density Multiple Reside	SFR-Basic

Accessory Dwelling Units

Index # - File Name: 1.0022 - Single Family Dwellings Data\_Snohomish County.pdf

96 104191 RK	PRD-LDMR	Low Density Multiple Reside	SFR-Basic
96 104192 RK	PRD-LDMR	Low Density Multiple Reside	SFR-Basic
96 102836 RK	PRD-LDMR	Low Density Multiple Reside	Single Family Res-Combo
96 103034 RK	PRD-LDMR	Low Density Multiple Reside	SFR-Basic
96 103036 RK	PRD-LDMR	Low Density Multiple Reside	SFR-Basic
96 103037 RK	PRD-LDMR	Low Density Multiple Reside	SFR-Basic
96 102775 RK	PRD-LDMR	Low Density Multiple Reside	Single Family Res-Combo
96 102776 RK	PRD-LDMR	Low Density Multiple Reside	Single Family Res-Combo
96 103082 RK	PRD-LDMR	Low Density Multiple Reside	SFR-Basic
96 103084 RK	PRD-LDMR	Low Density Multiple Reside	SFR-Basic
96 102950 RK	PRD-LDMR	Low Density Multiple Reside	SFR-Basic
96 102951 RK	PRD-LDMR	Low Density Multiple Reside	SFR-Basic
96 106307 RK	PRD-LDMR	Low Density Multiple Reside	SFR-Basic
96 106308 RK	PRD-LDMR	Low Density Multiple Reside	SFR-Basic
96 106311 RK	PRD-LDMR	Low Density Multiple Reside	SFR-Basic
96 106312 RK	PRD-LDMR	Low Density Multiple Reside	SFR-Basic
96 106314 RK	PRD-LDMR	Low Density Multiple Reside	SFR-Basic
96 102952 RK	PRD-LDMR	Low Density Multiple Reside	SFR-Basic
96 102954 RK	PRD-LDMR	Low Density Multiple Reside	SFR-Basic
96 102955 RK	PRD-LDMR	Low Density Multiple Reside	SFR-Basic
96 102956 RK	PRD-LDMR	Low Density Multiple Reside	SFR-Basic
96 102860 RK	R-5	Rural-5 Acre	Single Family Res-Combo
96 103453 MH	R-5	Rural-5 Acre	Double Wide
96 103116 RK	R-5	Rural-5 Acre	Single Family Res-Combo
96 108056 MH	R-5	Rural-5 Acre	Double Wide
96 103220 MH	SA-1	Suburban Agriculture-1 Acre	Triple Wide
96 103587 RK	R-5	Rural-5 Acre	Single Family Res-Combo
96 103020 RK	R-9,600	Residential 9,600 sq. ft.	Single Family Res-Combo
96 104200 RK	RRT-10	Rural Resource Transition-10	Single Family Res-Combo
96 103383 RK	T	Townhouse	SFR-Basic
96 103388 RK	T	Townhouse	SFR-Basic
96 103413 RK	T	Townhouse	SFR-Basic
96 103405 RK	T	Townhouse	SFR-Basic
96 108408 RK	T	Townhouse	SFR-Basic
96 108409 RK	T	Townhouse	SFR-Basic
96 108411 RK	T	Townhouse	Single Family Res-Combo
96 108413 RK	T	Townhouse	Single Family Res-Combo
96 109141 RK	T	Townhouse	Single Family Res-Combo
96 109142 RK	T	Townhouse	Single Family Res-Combo
96 103395 RK	T	Townhouse	SFR-Basic
96 103411 RK	T	Townhouse	SFR-Basic
96 103410 RK	T	Townhouse	SFR-Basic
96 103401 RK	T	Townhouse	SFR-Basic
96 103993 RK	R-5	Rural-5 Acre	Single Family Res-Combo
96 109522 RK	R-5	Rural-5 Acre	SFR-Basic
96 108429 RK	R-5	Rural-5 Acre	SFR-Basic
96 108428 RK	R-5	Rural-5 Acre	SFR-Basic



Accessory Dwelling Units

Index # - File Name: 1.0022 - Single Family Dwellings Data\_Snohomish County.pdf

96 106384 MH	R-5	Rural-5 Acre	Double Wide
96 102211 RK	R-5	Rural-5 Acre	Single Family Res-Combo
96 102223 RK	R-5	Rural-5 Acre	Single Family Res-Combo
96 102260 RK	R-5	Rural-5 Acre	Single Family Res-Combo
96 102275 MH	CITY	City	MH Park-Double Wide
96 105055 RK	R-5	Rural-5 Acre	Single Family Res-Combo
96 101493 RK	R-5	Rural-5 Acre	Single Family Res-Combo
96 102550 RK	R-5	Rural-5 Acre	Single Family Res-Combo
96 102390 MH	R-5	Rural-5 Acre	Double Wide
96 103650 RK	R-5	Rural-5 Acre	Single Family Res-Combo
96 102412 RK	R-5	Rural-5 Acre	Single Family Res-Combo
96 102496 MH	R-5	Rural-5 Acre	Double Wide
96 102505 RK	R-5	Rural-5 Acre	Single Family Res-Combo
96 102614 RK	R-5	Rural-5 Acre	Single Family Res-Combo
96 103160 MH	R-5	Rural-5 Acre	Double Wide
96 103719 RK	R-5	Rural-5 Acre	Single Family Res-Combo
96 107224 MH	A-10 : R-5	Agriculture-10 Acre : Rural-5	Single Wide
96 101852 RK	R-8,400	Residential 8,400 sq. ft.	Single Family Res-Combo
96 101825 RK	R-5	Rural-5 Acre	Single Family Res-Combo
96 101923 MH	R-5	Rural-5 Acre	Double Wide
96 102119 MH	R-5	Rural-5 Acre	Double Wide
96 107337 RK	PRD-20,000	Residential 20,000 sq. ft.	Single Family Res-Combo
96 105658 RK	PRD-20,000 : F	Low Density Multiple Reside	Single Family Res-Combo
96 101693 MH	CITY	City	MH Park-Double Wide
96 101696 MH	CITY	City	MH Park-Double Wide
96 102428 RK	R-5	Rural-5 Acre	Single Family Res-Combo
96 103083 RK	R-5	Rural-5 Acre	Single Family Res-Combo
96 103085 RK	R-5	Rural-5 Acre	Single Family Res-Combo
96 107685 RK	R-8,400	Residential 8,400 sq. ft.	Single Family Res-Combo
96 102059 MH	R-5	Rural-5 Acre	Triple Wide
96 102064 MH	CITY	City	MH Park-Double Wide
96 102103 MH	F	Forestry	Double Wide
96 101842 RK	CITY	City	Duplex-Basic
96 102140 RK	R-9,600	Residential 9,600 sq. ft.	Single Family Res-Combo
96 102245 MH	R-5	Rural-5 Acre	Double Wide
96 107645 RK	R-5 : RC	Rural Conservation : Rural-5	Single Family Res-Combo
96 104733 RK	R-5	Rural-5 Acre	Single Family Res-Combo
96 109932 RK	PRD-9,600	Residential 9,600 sq. ft.	SFR-Basic
96 110024 RK	PRD-9,600	Residential 9,600 sq. ft.	SFR-Basic
96 105077 RK	PRD-9,600	Residential 9,600 sq. ft.	Single Family Res-Combo
96 106895 RK	PRD-9,600	Residential 9,600 sq. ft.	SFR-Basic
96 103536 RK	PRD-9,600	Residential 9,600 sq. ft.	SFR-Basic
96 101265 RK	PRD-9,600	Residential 9,600 sq. ft.	Single Family Res-Combo
96 110062 RK	PRD-9,600	Residential 9,600 sq. ft.	Single Family Res-Combo
96 110023 RK	PRD-9,600	Residential 9,600 sq. ft.	SFR-Basic
96 102006 RK	CITY	City	Single Family Res-Combo
96 101835 RK	CITY	City	Duplex-Combo

Accessory Dwelling Units

Index # - File Name: 1.0022 - Single Family Dwellings Data\_Snohomish County.pdf

96 101837 RK	CITY	City	Duplex-Combo
96 102009 RK	PRD-9,600	Residential 9,600 sq. ft.	Single Family Res-Combo
96 107433 RK	PRD-9,600	Residential 9,600 sq. ft.	SFR-Basic
96 105247 RK	PRD-9,600	Residential 9,600 sq. ft.	Single Family Res-Combo
96 104753 RK	R-8,400	Residential 8,400 sq. ft.	SFR-Basic
96 104450 RK	R-8,400	Residential 8,400 sq. ft.	SFR-Basic
95 106934 RK	PRD-9,600	Residential 9,600 sq. ft.	Single Family Res-Combo
96 103351 RK	PRD-9,600	Residential 9,600 sq. ft.	SFR-Basic
96 105242 RK	PRD-9,600	Residential 9,600 sq. ft.	Single Family Res-Combo
96 108698 RK	PRD-LDMR	Low Density Multiple Reside	Single Family Res-Combo
96 104667 RK	PRD-LDMR	Low Density Multiple Reside	Single Family Res-Combo
96 105122 RK	PRD-LDMR	Low Density Multiple Reside	Single Family Res-Combo
96 106219 RK	PRD-20,000	Residential 20,000 sq. ft.	Single Family Res-Combo
96 103843 RK	PRD-20,000 : F	Low Density Multiple Reside	Single Family Res-Combo
96 101697 RK	PRD-20,000 : F	Low Density Multiple Reside	SFR-Basic
96 104215 RK	PRD-20,000 : F	Low Density Multiple Reside	Single Family Res-Combo
96 108694 MH	RRT-10	Rural Resource Transition-10	Double Wide
96 104252 MH	CITY	City	MH Park-Double Wide
96 104255 MH	R-5	Rural-5 Acre	Double Wide
96 105967 RK	R-8,400	Residential 8,400 sq. ft.	SFR-Basic
96 107157 RK	R-8,400	Residential 8,400 sq. ft.	SFR-Basic
96 107052 RK	R-8,400	Residential 8,400 sq. ft.	SFR-Basic
96 104323 RK	R-8,400	Residential 8,400 sq. ft.	SFR-Basic
96 104808 RK	R-8,400	Residential 8,400 sq. ft.	SFR-Basic
96 107725 RK	R-8,400	Residential 8,400 sq. ft.	SFR-Basic
96 106562 RK	R-8,400	Residential 8,400 sq. ft.	SFR-Basic
96 107150 RK	R-8,400	Residential 8,400 sq. ft.	SFR-Basic
96 102717 RK	R-8,400	Residential 8,400 sq. ft.	Single Family Res-Combo
96 104272 RK	R-8,400	Residential 8,400 sq. ft.	SFR-Basic
96 107151 RK	R-8,400	Residential 8,400 sq. ft.	SFR-Basic
96 105833 RK	R-8,400	Residential 8,400 sq. ft.	SFR-Basic
96 107153 RK	R-8,400	Residential 8,400 sq. ft.	SFR-Basic
96 105834 RK	R-8,400	Residential 8,400 sq. ft.	SFR-Basic
96 104275 RK	R-8,400	Residential 8,400 sq. ft.	SFR-Basic
96 100483 RK	R-8,400	Residential 8,400 sq. ft.	Single Family Res-Combo
96 107155 RK	R-8,400	Residential 8,400 sq. ft.	SFR-Basic
96 104276 RK	R-8,400	Residential 8,400 sq. ft.	SFR-Basic
96 105835 RK	R-8,400	Residential 8,400 sq. ft.	SFR-Basic
96 105836 RK	R-8,400	Residential 8,400 sq. ft.	SFR-Basic
96 104277 RK	R-8,400	Residential 8,400 sq. ft.	SFR-Basic
96 107156 RK	R-8,400	Residential 8,400 sq. ft.	SFR-Basic
96 104321 RK	R-8,400	Residential 8,400 sq. ft.	SFR-Basic
96 104278 RK	R-8,400	Residential 8,400 sq. ft.	SFR-Basic
96 104029 RK	R-8,400	Residential 8,400 sq. ft.	Single Family Res-Combo
96 104060 RK	R-5	Rural-5 Acre	Single Family Res-Combo
96 104090 RK	PRD-8,400	Residential 8,400 sq. ft.	SFR-Basic
96 104092 RK	PRD-8,400	Residential 8,400 sq. ft.	SFR-Basic

Accessory Dwelling Units

Index # - File Name: 1.0022 - Single Family Dwellings Data\_Snohomish County.pdf

96 106714 RK	PRD-8,400	Residential 8,400 sq. ft.	SFR-Basic
96 106716 RK	PRD-8,400	Residential 8,400 sq. ft.	SFR-Basic
96 100025 RK	PRD-8,400	Residential 8,400 sq. ft.	SFR-Basic
96 106719 RK	PRD-8,400	Residential 8,400 sq. ft.	SFR-Basic
96 104093 RK	PRD-8,400	Residential 8,400 sq. ft.	SFR-Basic
96 100024 RK	PRD-8,400	Residential 8,400 sq. ft.	Single Family Res-Combo
96 106323 RK	PRD-8,400	Residential 8,400 sq. ft.	Single Family Res-Combo
96 107204 RK	PRD-8,400	Residential 8,400 sq. ft.	SFR-Basic
96 107205 RK	PRD-8,400	Residential 8,400 sq. ft.	SFR-Basic
96 107206 RK	PRD-8,400	Residential 8,400 sq. ft.	SFR-Basic
96 107207 RK	PRD-8,400	Residential 8,400 sq. ft.	SFR-Basic
96 107208 RK	PRD-8,400	Residential 8,400 sq. ft.	SFR-Basic
96 107209 RK	PRD-8,400	Residential 8,400 sq. ft.	SFR-Basic
96 107210 RK	PRD-8,400	Residential 8,400 sq. ft.	SFR-Basic
96 100027 RK	PRD-8,400	Residential 8,400 sq. ft.	Single Family Res-Combo
96 104095 RK	PRD-8,400	Residential 8,400 sq. ft.	SFR-Basic
96 104097 RK	PRD-8,400	Residential 8,400 sq. ft.	SFR-Basic
96 104099 RK	PRD-8,400	Residential 8,400 sq. ft.	SFR-Basic
96 106695 RK	R-5	Rural-5 Acre	Single Family Res-Combo
96 104367 RK	R-5	Rural-5 Acre	Single Family Res-Combo
96 104362 RK	R-5	Rural-5 Acre	Single Family Res-Combo
96 109212 RK	R-5	Rural-5 Acre	Single Family Res-Combo
96 105157 RK	CITY	City	Single Family Res-Combo
96 103876 MH	NB	Neighborhood Business	MH Park-Double Wide
96 104725 RK	R-5	Rural-5 Acre	Single Family Res-Combo
96 104336 MH	R-5	Rural-5 Acre	Triple Wide
96 105963 RK	CITY	City	Single Family Res-Combo
96 105815 RK	R-8,400	Residential 8,400 sq. ft.	Single Family Res-Combo
96 104322 RK	R-8,400	Residential 8,400 sq. ft.	SFR-Basic
96 107726 RK	R-8,400	Residential 8,400 sq. ft.	SFR-Basic
96 104324 RK	R-8,400	Residential 8,400 sq. ft.	SFR-Basic
96 104325 RK	R-8,400	Residential 8,400 sq. ft.	SFR-Basic
96 104809 RK	R-8,400	Residential 8,400 sq. ft.	SFR-Basic
96 104279 RK	R-8,400	Residential 8,400 sq. ft.	SFR-Basic
96 105542 RK	R-5	Rural-5 Acre	SFR-Basic
96 104295 RK	R-9,600	Residential 9,600 sq. ft.	Single Family Res-Combo
96 104973 RK	R-9,600	Residential 9,600 sq. ft.	SFR-Basic
96 104971 RK	R-9,600	Residential 9,600 sq. ft.	SFR-Basic
96 107914 RK	R-5	Rural-5 Acre	Single Family Res-Combo
96 104621 RK	R-5	Rural-5 Acre	Single Family Res-Combo
96 104615 RK	R-5	Rural-5 Acre	Single Family Res-Combo
96 108184 RK	R-5	Rural-5 Acre	Single Family Res-Combo
96 104551 RK	R-5	Rural-5 Acre	Single Family Res-Combo
96 105858 MH	R-5	Rural-5 Acre	Double Wide
96 104769 RK	R-5	Rural-5 Acre	Single Family Res-Combo
96 104823 RK	R-9,600	Residential 9,600 sq. ft.	Single Family Res-Combo
96 106633 MH	R-5	Rural-5 Acre	Double Wide

Accessory Dwelling Units

Index # - File Name: 1.0022 - Single Family Dwellings Data\_Snohomish County.pdf

96 106848 RK	R-5	Rural-5 Acre	Single Family Res-Combo
96 104945 RK	CITY	City	Single Family Res-Combo
96 104950 RK	CITY	City	Single Family Res-Combo
96 109407 RK	CITY	City	SFR-Basic
96 110321 RK	CITY	City	SFR-Basic
96 104944 RK	CITY	City	Single Family Res-Combo
96 110320 RK	CITY	City	SFR-Basic
96 104949 RK	CITY	City	SFR-Basic
96 105044 RK	CITY	City	Single Family Res-Combo
96 110319 RK	CITY	City	SFR-Basic
96 110322 RK	CITY	City	SFR-Basic
96 105031 RK	R-5	Rural-5 Acre	Single Family Res-Combo
96 105032 RK	R-5	Rural-5 Acre	Single Family Res-Combo
96 105034 RK	R-5	Rural-5 Acre	Single Family Res-Combo
96 104910 MH	R-5	Rural-5 Acre	Double Wide
96 104986 RK	TRIBES	Native American Land	SFR-Basic
96 104957 MH	R-5	Rural-5 Acre	Double Wide
96 105072 MH	R-5	Rural-5 Acre	Double Wide
96 109627 MH	R-5	Rural-5 Acre	Triple Wide
96 105120 MH	CITY	City	MH Park-Double Wide
96 109080 RK	R-5	Rural-5 Acre	SFR-Basic
96 105299 RK	R-5	Rural-5 Acre	Single Family Res-Combo
96 105614 MH	R-12,500	Residential 12,500 sq. ft.	Double Wide
96 108861 MH	R-5	Rural-5 Acre	Double Wide
96 108102 RK	R-8,400	Residential 8,400 sq. ft.	Single Family Res-Combo
96 105609 RK	R-9,600	Residential 9,600 sq. ft.	Single Family Res-Combo
96 105650 MH	R-5	Rural-5 Acre	Triple Wide
96 107109 RK	R-9,600	Residential 9,600 sq. ft.	Single Family Res-Combo
96 104854 RK	R-9,600	Residential 9,600 sq. ft.	Single Family Res-Combo
96 104851 RK	R-9,600	Residential 9,600 sq. ft.	Single Family Res-Combo
96 105734 MH	R-5	Rural-5 Acre	Double Wide
96 105786 RK	SA-1	Suburban Agriculture-1 Acre	Single Family Res-Combo
96 105873 MH	R-5	Rural-5 Acre	Double Wide
96 105874 MH	R-5	Rural-5 Acre	Double Wide
96 105876 RK	RRT-10	Rural Resource Transition-10	Single Family Res-Combo
96 106060 RK	R-5	Rural-5 Acre	Single Family Res-Combo
96 105912 RK	RRT-10	Rural Resource Transition-10	Single Family Res-Combo
96 107617 RK	R-5	Rural-5 Acre	Single Family Res-Combo
96 109890 RK	CITY	City	Single Family Res-Combo
96 106132 RK	CITY	City	Duplex-Basic
96 106134 RK	CITY	City	Duplex-Basic
96 106136 RK	CITY	City	Duplex-Basic
96 106171 MH	CITY	City	MH Park-Double Wide
96 106190 RK	R-5	Rural-5 Acre	Single Family Res-Combo
96 106199 MH	NB	Neighborhood Business	MH Park-Double Wide
96 106206 RK	R-5	Rural-5 Acre	Single Family Res-Combo
96 106242 RK	R-5	Rural-5 Acre	Single Family Res-Combo

Accessory Dwelling Units

Index # - File Name: 1.0022 - Single Family Dwellings Data\_Snohomish County.pdf

96 106217 RK	R-5	Rural-5 Acre	Single Family Res-Combo
96 106265 MH	A-10	Agriculture-10 Acre	Double Wide
96 107099 RK	MR	Multiple Residential	Duplex-Combo
96 108050 MH	CITY	City	MH Park-Double Wide
96 106360 RK	R-5	Rural-5 Acre	Single Family Res-Combo
96 106375 MH	R-5	Rural-5 Acre	Double Wide
96 106972 MH	R-12,500	Residential 12,500 sq. ft.	Single Wide
96 106964 MH	R-5	Rural-5 Acre	Double Wide
96 106285 RK	LDMR	Low Density Multiple Reside	Duplex-Basic
96 107704 MH	R-5	Rural-5 Acre	Double Wide
96 106520 RK	R-7,200	Residential 7,200 sq. ft.	Duplex-Combo
96 106496 MH	CITY	City	MH Park-Single Wide
96 107706 RK	CITY	City	SFR-Basic
96 107707 RK	CITY	City	SFR-Basic
96 110451 RK	CITY	City	SFR-Basic
96 106529 RK	CITY	City	SFR-Basic
96 106530 RK	CITY	City	SFR-Basic
96 106531 RK	CITY	City	SFR-Basic
96 106532 RK	CITY	City	SFR-Basic
96 106669 RK	R-9,600	Residential 9,600 sq. ft.	SFR-Basic
96 105329 RK	R-9,600	Residential 9,600 sq. ft.	Single Family Res-Combo
96 106671 RK	R-9,600	Residential 9,600 sq. ft.	Single Family Res-Combo
96 107955 RK	R-9,600	Residential 9,600 sq. ft.	Single Family Res-Combo
96 108327 RK	R-9,600	Residential 9,600 sq. ft.	Single Family Res-Combo
96 106670 RK	R-9,600	Residential 9,600 sq. ft.	SFR-Basic
96 110453 RK	CITY	City	SFR-Basic
96 106590 RK	R-5	Rural-5 Acre	Single Family Res-Combo
96 106626 MH	R-5	Rural-5 Acre	Double Wide
96 107020 MH	R-5	Rural-5 Acre	Double Wide
96 106644 MH	R-5	Rural-5 Acre	Triple Wide
96 106680 RK	PRD-9,600	Residential 9,600 sq. ft.	SFR-Basic
96 106647 MH	R-5	Rural-5 Acre	Double Wide
96 106663 RK	R-5	Rural-5 Acre	Single Family Res-Combo
96 106730 RK	CITY	City	Duplex-Combo
96 108351 MH	LDMR	Low Density Multiple Reside	Double Wide
96 110052 RK	CITY	City	SFR-Basic
96 105416 RK	CITY	City	Single Family Res-Combo
96 105417 RK	CITY	City	Single Family Res-Combo
96 102011 RK	CITY	City	Single Family Res-Combo
96 106722 RK	CITY	City	Duplex-Basic
96 106977 MH	R-5	Rural-5 Acre	Double Wide
96 108157 MH	R-5	Rural-5 Acre	Single Wide
97 104755 RK	R-7,200	Residential 7,200 sq. ft.	Single Family Res-Combo
97 100328 RK	R-9,600	Residential 9,600 sq. ft.	Single Family Res-Combo
97 105055 RK	R-5	Rural-5 Acre	Single Family Res-Combo
97 101400 RK	CITY	City	SFR-Basic
97 106736 MH	R-5	Rural-5 Acre	Double Wide

Accessory Dwelling Units

Index # - File Name: 1.0022 - Single Family Dwellings Data\_Snohomish County.pdf

97 100091 MH	CITY	City	MH Park-Double Wide
97 101040 MH	CITY	City	Double Wide
97 103886 RK	R-5	Rural-5 Acre	Single Family Res-Combo
96 108641 RK	R-7,200	Residential 7,200 sq. ft.	Single Family Res-Combo
97 105012 RK	F	Forestry	Single Family Res-Combo
97 100850 MH	R-5	Rural-5 Acre	Double Wide
97 106926 RK	R-5	Rural-5 Acre	Single Family Res-Combo
97 105700 RK	RD	Rural Diversification	Single Family Res-Combo
97 107044 RK	R-5	Rural-5 Acre	Single Family Res-Combo
97 104810 RK	CITY	City	Single Family Res-Combo
97 100778 RK	R-8,400	Residential 8,400 sq. ft.	Single Family Res-Combo
97 110040 RK	R-5	Rural-5 Acre	Single Family Res-Combo
96 109754 RK	R-5	Rural-5 Acre	Single Family Res-Combo
97 110413 MH	R-5	Rural-5 Acre	Double Wide
97 109160 MH	F	Forestry	Double Wide
97 100589 RK	CITY	City	SFR-Basic
97 100584 RK	CITY	City	SFR-Basic
97 100586 RK	CITY	City	SFR-Basic
97 100587 RK	CITY	City	SFR-Basic
97 102856 RK	R-5	Rural-5 Acre	Single Family Res-Combo
97 101208 RK	R-5	Rural-5 Acre	Single Family Res-Combo
97 101210 RK	R-5	Rural-5 Acre	Single Family Res-Combo
97 107729 RK	R-5	Rural-5 Acre	SFR-Basic
96 110763 RK	R-5	Rural-5 Acre	Single Family Res-Combo
97 103036 RK	R-5	Rural-5 Acre	Single Family Res-Combo
97 107912 RK	R-5	Rural-5 Acre	SFR-Basic
97 106971 RK	R-5	Rural-5 Acre	Single Family Res-Combo
97 109840 RK	LDMR	Low Density Multiple Reside	SFR-Basic
97 109842 RK	LDMR	Low Density Multiple Reside	SFR-Basic
97 107681 RK	LDMR	Low Density Multiple Reside	Single Family Res-Combo
97 109844 RK	LDMR	Low Density Multiple Reside	SFR-Basic
97 109845 RK	LDMR	Low Density Multiple Reside	SFR-Basic
97 109855 RK	LDMR	Low Density Multiple Reside	SFR-Basic
97 109843 RK	LDMR	Low Density Multiple Reside	SFR-Basic
97 109853 RK	LDMR	Low Density Multiple Reside	SFR-Basic
97 109854 RK	LDMR	Low Density Multiple Reside	SFR-Basic
97 109841 RK	LDMR	Low Density Multiple Reside	SFR-Basic
97 100413 RK	R-8,400	Residential 8,400 sq. ft.	Single Family Res-Combo
97 100767 RK	R-8,400	Residential 8,400 sq. ft.	SFR-Basic
97 100249 RK	R-8,400	Residential 8,400 sq. ft.	SFR-Basic
97 100248 RK	R-8,400	Residential 8,400 sq. ft.	SFR-Basic
97 100769 RK	R-8,400	Residential 8,400 sq. ft.	SFR-Basic
97 105419 RK	CITY	City	Single Family Res-Combo
97 101726 RK	F	Forestry	Single Family Res-Combo
97 102996 RK	R-5	Rural-5 Acre	SFR-Basic
97 100557 RK	R-9,600	Residential 9,600 sq. ft.	Single Family Res-Combo
97 100245 RK	R-8,400	Residential 8,400 sq. ft.	SFR-Basic

Accessory Dwelling Units

Index # - File Name: 1.0022 - Single Family Dwellings Data\_Snohomish County.pdf

97 100247 RK	R-8,400	Residential 8,400 sq. ft.	SFR-Basic
97 109837 RK	LDMR	Low Density Multiple Reside	SFR-Basic
97 105318 RK	R-5	Rural-5 Acre	Single Family Res-Combo
97 103906 RK	PRD-9,600	Residential 9,600 sq. ft.	Single Family Res-Combo
97 105968 RK	PRD-20,000	Residential 20,000 sq. ft.	Single Family Res-Combo
97 100814 RK	PRD-20,000	Residential 20,000 sq. ft.	Single Family Res-Combo
96 102574 RK	PRD-20,000	Low Density Multiple Reside	Single Family Res-Combo
97 102067 RK	PRD-20,000	Low Density Multiple Reside	Single Family Res-Combo
97 107236 RK	PRD-20,000	Residential 20,000 sq. ft.	Single Family Res-Combo
97 100288 RK	PRD-LDMR	Low Density Multiple Reside	Single Family Res-Combo
97 110489 RK	PRD-LDMR	Low Density Multiple Reside	Single Family Res-Combo
96 109442 RK	PRD-LDMR	Low Density Multiple Reside	Single Family Res-Combo
97 100528 RK	PRD-LDMR	Low Density Multiple Reside	Single Family Res-Combo
97 101941 RK	PRD-LDMR	Low Density Multiple Reside	Single Family Res-Combo
97 103194 RK	PRD-9,600	Residential 9,600 sq. ft.	SFR-Basic
97 104342 RK	PRD-LDMR	Low Density Multiple Reside	Single Family Res-Combo
97 105136 RK	PRD-9,600	Residential 9,600 sq. ft.	SFR-Basic
97 103193 RK	PRD-9,600	Residential 9,600 sq. ft.	SFR-Basic
97 105135 RK	PRD-9,600	Residential 9,600 sq. ft.	SFR-Basic
97 104580 RK	PRD-LDMR	Low Density Multiple Reside	Single Family Res-Combo
97 103732 RK	R-8,400	Residential 8,400 sq. ft.	SFR-Basic
97 103735 RK	R-8,400	Residential 8,400 sq. ft.	SFR-Basic
97 103730 RK	R-8,400	Residential 8,400 sq. ft.	SFR-Basic
97 103705 RK	R-8,400	Residential 8,400 sq. ft.	SFR-Basic
97 103699 RK	R-8,400	Residential 8,400 sq. ft.	SFR-Basic
97 107220 RK	R-8,400	Residential 8,400 sq. ft.	SFR-Basic
97 107217 RK	R-8,400	Residential 8,400 sq. ft.	SFR-Basic
97 106521 RK	R-8,400	Residential 8,400 sq. ft.	SFR-Basic
97 106869 RK	R-8,400	Residential 8,400 sq. ft.	SFR-Basic
97 108979 RK	R-8,400	Residential 8,400 sq. ft.	SFR-Basic
97 106523 RK	R-8,400	Residential 8,400 sq. ft.	SFR-Basic
97 101850 RK	PRD-9,600	Residential 9,600 sq. ft.	SFR-Basic
97 105137 RK	PRD-9,600	Residential 9,600 sq. ft.	SFR-Basic
97 101849 RK	PRD-9,600	Residential 9,600 sq. ft.	SFR-Basic
97 103907 RK	PRD-9,600	Residential 9,600 sq. ft.	Single Family Res-Combo
97 103908 RK	PRD-9,600	Residential 9,600 sq. ft.	Single Family Res-Combo
97 102212 RK	R-8,400	Residential 8,400 sq. ft.	Single Family Res-Combo
97 101155 RK	R-8,400	Residential 8,400 sq. ft.	SFR-Basic
97 100886 RK	R-8,400	Residential 8,400 sq. ft.	SFR-Basic
97 100884 RK	R-8,400	Residential 8,400 sq. ft.	SFR-Basic
97 100885 RK	R-8,400	Residential 8,400 sq. ft.	SFR-Basic
97 100887 RK	R-8,400	Residential 8,400 sq. ft.	Single Family Res-Combo
97 100880 RK	R-8,400	Residential 8,400 sq. ft.	SFR-Basic
97 100883 RK	R-8,400	Residential 8,400 sq. ft.	SFR-Basic
97 100872 RK	R-8,400	Residential 8,400 sq. ft.	SFR-Basic
97 100874 RK	R-8,400	Residential 8,400 sq. ft.	SFR-Basic
97 103213 RK	R-8,400	Residential 8,400 sq. ft.	SFR-Basic

Accessory Dwelling Units

Index # - File Name: 1.0022 - Single Family Dwellings Data\_Snohomish County.pdf

97 102638 RK	R-8,400	Residential 8,400 sq. ft.	SFR-Basic
97 100879 RK	R-8,400	Residential 8,400 sq. ft.	Single Family Res-Combo
97 100889 RK	R-8,400	Residential 8,400 sq. ft.	Single Family Res-Combo
97 105601 RK	R-8,400	Residential 8,400 sq. ft.	SFR-Basic
97 100882 RK	R-8,400	Residential 8,400 sq. ft.	SFR-Basic
97 101154 RK	R-8,400	Residential 8,400 sq. ft.	Single Family Res-Combo
97 100870 RK	R-8,400	Residential 8,400 sq. ft.	SFR-Basic
97 100878 RK	R-8,400	Residential 8,400 sq. ft.	SFR-Basic
97 105660 RK	R-5	Rural-5 Acre	Single Family Res-Combo
96 109611 RK	R-5	Rural-5 Acre	Single Family Res-Combo
96 102128 RK	LDMR	Low Density Multiple Reside	Single Family Res-Combo
97 105086 RK	PRD-LDMR	Low Density Multiple Reside	Single Family Res-Combo
97 105469 MH	R-5	Rural-5 Acre	Double Wide
96 108002 RK	R-5	Rural-5 Acre	Single Family Res-Combo
97 101395 RK	R-5	Rural-5 Acre	Single Family Res-Combo
96 103070 RK	R-5	Rural-5 Acre	Single Family Res-Combo
97 104668 RK	R-5	Rural-5 Acre	Single Family Res-Combo
97 104572 RK	R-5	Rural-5 Acre	Single Family Res-Combo
97 103970 RK	R-5	Rural-5 Acre	Single Family Res-Combo
97 104368 RK	R-5	Rural-5 Acre	Single Family Res-Combo
96 107179 RK	R-5	Rural-5 Acre	Single Family Res-Combo
96 110173 RK	CITY	City	Single Family Res-Combo
96 110174 RK	CITY	City	Single Family Res-Combo
96 110169 RK	CITY	City	Single Family Res-Combo
96 110182 RK	CITY	City	Single Family Res-Combo
96 110175 RK	CITY	City	Single Family Res-Combo
96 110179 RK	CITY	City	Single Family Res-Combo
96 110170 RK	CITY	City	Single Family Res-Combo
96 110178 RK	CITY	City	Single Family Res-Combo
96 110181 RK	CITY	City	Single Family Res-Combo
97 110251 MH	R-5	Rural-5 Acre	Single Wide
97 109456 RK	R-5	Rural-5 Acre	Single Family Res-Combo
97 104168 RK	R-5	Rural-5 Acre	Single Family Res-Combo
96 108815 RK	R-5	Rural-5 Acre	Single Family Res-Combo
96 108816 RK	R-5	Rural-5 Acre	Single Family Res-Combo
97 104409 RK	R-5	Rural-5 Acre	Single Family Res-Combo
97 105986 RK	R-5	Rural-5 Acre	Single Family Res-Combo
97 109349 RK	R-5	Rural-5 Acre	SFR-Basic
97 101143 RK	R-5	Rural-5 Acre	Single Family Res-Combo
97 107163 RK	R-5	Rural-5 Acre	Single Family Res-Combo
97 103618 RK	R-5	Rural-5 Acre	Single Family Res-Combo
96 110005 RK	R-5	Rural-5 Acre	Single Family Res-Combo
97 100683 RK	R-5	Rural-5 Acre	Single Family Res-Combo
97 100068 RK	CITY	City	SFR-Basic
97 100838 RK	CITY	City	SFR-Basic
97 100839 RK	CITY	City	SFR-Basic
97 100835 RK	CITY	City	SFR-Basic



Accessory Dwelling Units

Index # - File Name: 1.0022 - Single Family Dwellings Data\_Snohomish County.pdf

97 100840 RK	CITY	City	SFR-Basic
97 100070 RK	CITY	City	SFR-Basic
97 100072 RK	CITY	City	SFR-Basic
97 107552 RK	RRT-10	Rural Resource Transition-1	Single Family Res-Combo
97 101488 RK	R-5	Rural-5 Acre	Single Family Res-Combo
97 110674 RK	R-5	Rural-5 Acre	Single Family Res-Combo
97 107607 RK	R-5	Rural-5 Acre	Single Family Res-Combo
97 107242 RK	R-5	Rural-5 Acre	Single Family Res-Combo
97 108104 RK	R-5	Rural-5 Acre	SFR-Basic
97 107608 RK	R-5	Rural-5 Acre	Single Family Res-Combo
97 108395 RK	R-5	Rural-5 Acre	Single Family Res-Combo
97 104107 RK	R-5	Rural-5 Acre	Single Family Res-Combo
97 103392 RK	R-5	Rural-5 Acre	SFR-Basic
97 108102 RK	R-5	Rural-5 Acre	Single Family Res-Combo
97 109502 RK	R-5	Rural-5 Acre	Single Family Res-Combo
97 105077 RK	R-5	Rural-5 Acre	Single Family Res-Combo
96 110765 RK	R-8,400	Residential 8,400 sq. ft.	Single Family Res-Combo
97 100388 RK	R-8,400	Residential 8,400 sq. ft.	SFR-Basic
97 102473 RK	PRD-9,600	Residential 9,600 sq. ft.	SFR-Basic
97 102588 RK	PRD-9,600	Residential 9,600 sq. ft.	SFR-Basic
97 109789 RK	PRD-9,600	Residential 9,600 sq. ft.	Single Family Res-Combo
97 109788 RK	PRD-9,600	Residential 9,600 sq. ft.	SFR-Basic
97 105196 RK	PRD-9,600	Residential 9,600 sq. ft.	Single Family Res-Combo
97 105194 RK	PRD-9,600	Residential 9,600 sq. ft.	Single Family Res-Combo
97 105199 RK	PRD-9,600	Residential 9,600 sq. ft.	Single Family Res-Combo
96 110383 RK	PRD-9,600	Residential 9,600 sq. ft.	Single Family Res-Combo
97 109115 RK	R-5	Rural-5 Acre	Single Family Res-Combo
97 103282 RK	RRT-10	Rural Resource Transition-1	SFR-Basic
97 100508 RK	CITY	City	Single Family Res-Combo
97 100513 RK	CITY	City	SFR-Basic
97 103281 RK	RRT-10	Rural Resource Transition-1	SFR-Basic
97 100842 RK	RRT-10	Rural Resource Transition-1	Single Family Res-Combo
97 103068 RK	RRT-10	Rural Resource Transition-1	SFR-Basic
97 103066 RK	RRT-10	Rural Resource Transition-1	SFR-Basic
97 103065 RK	RRT-10	Rural Resource Transition-1	SFR-Basic
97 103659 RK	CITY	City	Single Family Res-Combo
97 100286 RK	CITY	City	SFR-Basic
96 110689 RK	CITY	City	SFR-Basic
97 104958 RK	CITY	City	SFR-Basic
97 102813 RK	CITY	City	SFR-Basic
97 100504 RK	CITY	City	Single Family Res-Combo
97 100236 RK	CITY	City	SFR-Basic
97 103873 RK	CITY	City	SFR-Basic
97 102586 RK	CITY	City	Single Family Res-Combo
97 100256 RK	CITY	City	SFR-Basic
97 102585 RK	CITY	City	SFR-Basic
97 107474 RK	R-5	Rural-5 Acre	Single Family Res-Combo

Accessory Dwelling Units

Index # - File Name: 1.0022 - Single Family Dwellings Data\_Snohomish County.pdf

97 110774 RK	CITY	City	Duplex-Combo
97 100225 RK	R-5	Rural-5 Acre	Single Family Res-Combo
97 104575 RK	R-5	Rural-5 Acre	SFR-Basic
97 108562 RK	R-5	Rural-5 Acre	Single Family Res-Combo
96 100735 MH	R-5	Rural-5 Acre	Double Wide
97 102779 RK	R-5	Rural-5 Acre	Single Family Res-Combo
96 101267 MH	R-5	Rural-5 Acre	Double Wide
97 100280 RK	R-9,600	Residential 9,600 sq. ft.	SFR-Basic
97 100278 RK	R-9,600	Residential 9,600 sq. ft.	SFR-Basic
97 106501 RK	R-9,600	Residential 9,600 sq. ft.	Single Family Res-Combo
97 105082 RK	R-5	Rural-5 Acre	Single Family Res-Combo
97 100276 RK	R-9,600	Residential 9,600 sq. ft.	SFR-Basic
97 100279 RK	R-9,600	Residential 9,600 sq. ft.	SFR-Basic
97 100561 RK	R-9,600	Residential 9,600 sq. ft.	SFR-Basic
97 108507 RK	F	Forestry	Single Family Res-Combo
96 110550 RK	RC	Rural Conservation	Single Family Res-Combo
97 101659 RK	R-5	Rural-5 Acre	Single Family Res-Combo
96 110587 MH	R-5	Rural-5 Acre	Double Wide
97 107473 RK	R-5	Rural-5 Acre	Single Family Res-Combo
96 110930 RK	R-5	Rural-5 Acre	Single Family Res-Combo
96 110767 RK	R-9,600	Residential 9,600 sq. ft.	Single Family Res-Combo
96 110816 RK	RRT-10	Rural Resource Transition-10	Single Family Res-Combo
97 100101 RK	CITY	City	SFR-Basic
97 100105 RK	CITY	City	SFR-Basic
97 101951 RK	CITY	City	SFR-Basic
97 101952 RK	CITY	City	SFR-Basic
97 101950 RK	CITY	City	SFR-Basic
97 101947 RK	CITY	City	SFR-Basic
97 101949 RK	CITY	City	SFR-Basic
97 100097 RK	CITY	City	SFR-Basic
97 100098 RK	CITY	City	SFR-Basic
97 100099 RK	CITY	City	SFR-Basic
97 100100 RK	CITY	City	SFR-Basic
97 100104 RK	CITY	City	SFR-Basic
97 100103 RK	CITY	City	SFR-Basic
97 100102 RK	CITY	City	SFR-Basic
97 101538 RK	R-5	Rural-5 Acre	Single Family Res-Combo
97 104457 RK	R-5	Rural-5 Acre	Single Family Res-Combo
97 100035 RK	R-5	Rural-5 Acre	Single Family Res-Combo
97 109979 RK	R-5	Rural-5 Acre	Single Family Res-Combo
97 102591 RK	R-5	Rural-5 Acre	Single Family Res-Combo
97 105697 RK	R-5	Rural-5 Acre	Single Family Res-Combo
96 110543 RK	R-5	Rural-5 Acre	Single Family Res-Combo
97 104624 RK	R-5	Rural-5 Acre	Single Family Res-Combo
97 104619 RK	R-5	Rural-5 Acre	Single Family Res-Combo
97 102643 RK	R-5	Rural-5 Acre	Single Family Res-Combo
97 104118 RK	R-5	Rural-5 Acre	Single Family Res-Combo

Accessory Dwelling Units

Index # - File Name: 1.0022 - Single Family Dwellings Data\_Snohomish County.pdf

97 102595 RK	R-5	Rural-5 Acre	Single Family Res-Combo
97 106046 RK	R-5	Rural-5 Acre	Single Family Res-Combo
97 105874 RK	R-5	Rural-5 Acre	Single Family Res-Combo
97 106051 RK	R-5	Rural-5 Acre	Single Family Res-Combo
97 105889 RK	R-5	Rural-5 Acre	Single Family Res-Combo
97 105876 RK	R-5	Rural-5 Acre	Single Family Res-Combo
97 104777 RK	R-5	Rural-5 Acre	Single Family Res-Combo
97 106047 RK	R-5	Rural-5 Acre	Single Family Res-Combo
96 110961 RK	R-5	Rural-5 Acre	Single Family Res-Combo
97 104986 RK	R-5	Rural-5 Acre	Single Family Res-Combo
97 105885 RK	R-5	Rural-5 Acre	Single Family Res-Combo
97 104119 RK	R-5	Rural-5 Acre	Single Family Res-Combo
97 106053 RK	R-5	Rural-5 Acre	Single Family Res-Combo
96 110959 RK	R-5	Rural-5 Acre	Single Family Res-Combo
96 110938 RK	R-5	Rural-5 Acre	Single Family Res-Combo
97 102641 RK	R-5	Rural-5 Acre	Single Family Res-Combo
96 110892 MH	R-5	Rural-5 Acre	Double Wide
96 110891 MH	R-5	Rural-5 Acre	Double Wide
97 111262 RK	R-5	Rural-5 Acre	Single Family Res-Combo
96 110712 RK	R-7,200	Residential 7,200 sq. ft.	SFR-Basic
96 110714 RK	R-7,200	Residential 7,200 sq. ft.	SFR-Basic
96 110715 RK	R-7,200	Residential 7,200 sq. ft.	SFR-Basic
96 110716 RK	R-7,200	Residential 7,200 sq. ft.	SFR-Basic
96 110718 RK	R-7,200	Residential 7,200 sq. ft.	SFR-Basic
97 101959 RK	R-7,200	Residential 7,200 sq. ft.	SFR-Basic
97 101958 RK	R-7,200	Residential 7,200 sq. ft.	SFR-Basic
97 101957 RK	R-7,200	Residential 7,200 sq. ft.	SFR-Basic
97 101956 RK	R-7,200	Residential 7,200 sq. ft.	SFR-Basic
97 101955 RK	R-7,200	Residential 7,200 sq. ft.	SFR-Basic
96 110722 RK	R-7,200	Residential 7,200 sq. ft.	SFR-Basic
96 110721 RK	R-7,200	Residential 7,200 sq. ft.	SFR-Basic
96 110720 RK	R-7,200	Residential 7,200 sq. ft.	SFR-Basic
96 110719 RK	R-7,200	Residential 7,200 sq. ft.	SFR-Basic
96 110890 RK	R-5	Rural-5 Acre	Single Family Res-Combo
97 100259 RK	CITY	City	Single Family Res-Combo
97 100257 RK	CITY	City	Single Family Res-Combo
96 109219 RK	R-5	Rural-5 Acre	Single Family Res-Combo
97 101235 RK	R-5	Rural-5 Acre	Single Family Res-Combo
97 101437 RK	R-9,600	Residential 9,600 sq. ft.	Single Family Res-Combo
96 110939 RK	R-7,200	Residential 7,200 sq. ft.	Single Family Res-Combo
96 110561 RK	R-5	Rural-5 Acre	Single Family Res-Combo
97 100673 RK	R-5	Rural-5 Acre	SFR-Basic
97 100674 RK	R-5	Rural-5 Acre	SFR-Basic
97 101120 RK	R-5	Rural-5 Acre	SFR-Basic
96 110560 RK	R-5	Rural-5 Acre	Single Family Res-Combo
97 102824 RK	R-5	Rural-5 Acre	Single Family Res-Combo
97 102451 RK	R-5	Rural-5 Acre	Single Family Res-Combo

Accessory Dwelling Units

Index # - File Name: 1.0022 - Single Family Dwellings Data\_Snohomish County.pdf

97 102451 MH	R-5	Rural-5 Acre	Double Wide
97 102089 RK	R-5	Rural-5 Acre	Single Family Res-Combo
96 110669 RK	R-5	Rural-5 Acre	Single Family Res-Combo
97 100361 RK	R-5	Rural-5 Acre	SFR-Basic
97 102296 RK	R-5	Rural-5 Acre	Single Family Res-Combo
96 110316 RK	R-5	Rural-5 Acre	Single Family Res-Combo
97 102512 RK	MR	Multiple Residential	Single Family Res-Combo
96 107345 RK	R-5	Rural-5 Acre	Single Family Res-Combo
96 110285 RK	R-5	Rural-5 Acre	Single Family Res-Combo
97 100851 RK	CITY	City	SFR-Basic
97 100601 RK	R-9,600	Residential 9,600 sq. ft.	SFR-Basic
97 102917 RK	R-9,600	Residential 9,600 sq. ft.	SFR-Basic
97 102921 RK	R-9,600	Residential 9,600 sq. ft.	Single Family Res-Combo
97 102922 RK	R-9,600	Residential 9,600 sq. ft.	Single Family Res-Combo
96 110787 RK	R-9,600	Residential 9,600 sq. ft.	Single Family Res-Combo
96 110351 RK	R-9,600	Residential 9,600 sq. ft.	Single Family Res-Combo
96 106783 RK	R-9,600	Residential 9,600 sq. ft.	Single Family Res-Combo
96 106780 RK	R-9,600	Residential 9,600 sq. ft.	Single Family Res-Combo
97 100605 RK	R-9,600	Residential 9,600 sq. ft.	SFR-Basic
97 101714 RK	R-5	Rural-5 Acre	Single Family Res-Combo
97 103504 RK	R-8,400	Residential 8,400 sq. ft.	SFR-Basic
97 103505 RK	R-8,400	Residential 8,400 sq. ft.	SFR-Basic
97 101234 RK	R-8,400	Residential 8,400 sq. ft.	Single Family Res-Combo
97 102794 RK	R-8,400	Residential 8,400 sq. ft.	SFR-Basic
97 102793 RK	R-8,400	Residential 8,400 sq. ft.	SFR-Basic
96 110800 RK	R-8,400	Residential 8,400 sq. ft.	SFR-Basic
97 101229 RK	R-8,400	Residential 8,400 sq. ft.	SFR-Basic
96 110798 RK	R-8,400	Residential 8,400 sq. ft.	SFR-Basic
96 107668 RK	R-8,400	Residential 8,400 sq. ft.	Single Family Res-Combo
96 109894 RK	R-5	Rural-5 Acre	Single Family Res-Combo
96 109895 RK	R-5	Rural-5 Acre	Single Family Res-Combo
96 109876 RK	R-5	Rural-5 Acre	Single Family Res-Combo
96 110593 RK	R-9,600	Residential 9,600 sq. ft.	SFR-Basic
97 100551 RK	R-5	Rural-5 Acre	Single Family Res-Combo
96 110027 RK	R-5	Rural-5 Acre	Single Family Res-Combo
97 105476 RK	R-5	Rural-5 Acre	Single Family Res-Combo
97 100803 RK	R-9,600	Residential 9,600 sq. ft.	SFR-Basic
97 105353 RK	R-9,600	Residential 9,600 sq. ft.	SFR-Basic
97 106262 RK	R-9,600	Residential 9,600 sq. ft.	SFR-Basic
97 103095 RK	R-9,600	Residential 9,600 sq. ft.	SFR-Basic
97 100255 RK	R-9,600	Residential 9,600 sq. ft.	SFR-Basic
97 105354 RK	R-9,600	Residential 9,600 sq. ft.	SFR-Basic
97 110221 RK	R-9,600	Residential 9,600 sq. ft.	SFR-Basic
97 101313 RK	R-9,600	Residential 9,600 sq. ft.	SFR-Basic
97 110222 RK	R-9,600	Residential 9,600 sq. ft.	SFR-Basic
97 106196 RK	R-9,600	Residential 9,600 sq. ft.	SFR-Basic
97 100802 RK	R-9,600	Residential 9,600 sq. ft.	SFR-Basic

Accessory Dwelling Units

Index # - File Name: 1.0022 - Single Family Dwellings Data\_Snohomish County.pdf

97 106195 RK	R-9,600	Residential 9,600 sq. ft.	SFR-Basic
96 110532 RK	R-9,600	Residential 9,600 sq. ft.	Single Family Res-Combo
97 100800 RK	R-9,600	Residential 9,600 sq. ft.	Single Family Res-Combo
97 107080 RK	R-9,600	Residential 9,600 sq. ft.	SFR-Basic
97 105818 RK	R-9,600	Residential 9,600 sq. ft.	SFR-Basic
97 108185 RK	R-9,600	Residential 9,600 sq. ft.	SFR-Basic
97 102811 RK	R-9,600	Residential 9,600 sq. ft.	Single Family Res-Combo
97 102798 RK	R-9,600	Residential 9,600 sq. ft.	SFR-Basic
97 105817 RK	R-9,600	Residential 9,600 sq. ft.	SFR-Basic
97 107077 RK	R-9,600	Residential 9,600 sq. ft.	SFR-Basic
97 106194 RK	R-9,600	Residential 9,600 sq. ft.	SFR-Basic
97 104375 RK	R-9,600	Residential 9,600 sq. ft.	SFR-Basic
97 106753 RK	R-9,600	Residential 9,600 sq. ft.	SFR-Basic
97 103683 RK	R-9,600	Residential 9,600 sq. ft.	SFR-Basic
97 108183 RK	R-9,600	Residential 9,600 sq. ft.	SFR-Basic
97 106048 RK	R-9,600	Residential 9,600 sq. ft.	SFR-Basic
97 108722 RK	R-9,600	Residential 9,600 sq. ft.	SFR-Basic
96 109593 RK	R-5	Rural-5 Acre	Single Family Res-Combo
97 106261 RK	R-9,600	Residential 9,600 sq. ft.	SFR-Basic
97 106042 RK	R-9,600	Residential 9,600 sq. ft.	SFR-Basic
97 108720 RK	R-9,600	Residential 9,600 sq. ft.	SFR-Basic
97 106307 RK	R-9,600	Residential 9,600 sq. ft.	SFR-Basic
97 100823 RK	R-9,600	Residential 9,600 sq. ft.	SFR-Basic
96 110206 RK	R-5	Rural-5 Acre	Single Family Res-Combo
97 103345 RK	R-5	Rural-5 Acre	Single Family Res-Combo
97 110681 MH	CITY	City	MH Park-Double Wide
97 101329 RK	R-9,600	Residential 9,600 sq. ft.	SFR-Basic
97 100529 MH	R-5	Rural-5 Acre	Double Wide
97 102682 MH	R-5	Rural-5 Acre	Double Wide
97 107697 RK	R-5	Rural-5 Acre	Single Family Res-Combo
97 107515 MH	R-5	Rural-5 Acre	Double Wide
97 102489 RK	R-5	Rural-5 Acre	Single Family Res-Combo
97 102646 RK	R-5	Rural-5 Acre	Single Family Res-Combo
97 105582 RK	R-5	Rural-5 Acre	Single Family Res-Combo
96 109079 RK	R-5	Rural-5 Acre	Single Family Res-Combo
96 109089 RK	R-5	Rural-5 Acre	Single Family Res-Combo
97 100794 MH	R-5	Rural-5 Acre	Double Wide
97 100796 MH	R-5	Rural-5 Acre	Double Wide
97 101181 RK	R-5	Rural-5 Acre	Single Family Res-Combo
96 109810 MH	R-5	Rural-5 Acre	Double Wide
97 105925 RK	CITY	City	SFR-Basic
97 106528 RK	CITY	City	Single Family Res-Combo
95 108375 RK	CITY	City	Single Family Res-Combo
96 110046 RK	F	Forestry	Single Family Res-Combo
97 110302 RK	R-5	Rural-5 Acre	Single Family Res-Combo
97 104820 RK	R-5	Rural-5 Acre	Single Family Res-Combo
97 105328 RK	R-5	Rural-5 Acre	Single Family Res-Combo

Accessory Dwelling Units

Index # - File Name: 1.0022 - Single Family Dwellings Data\_Snohomish County.pdf

97 101546 RK	R-5	Rural-5 Acre	Single Family Res-Combo
97 105397 RK	R-5	Rural-5 Acre	Single Family Res-Combo
97 104738 RK	R-5	Rural-5 Acre	SFR-Basic
97 102197 RK	R-5	Rural-5 Acre	Single Family Res-Combo
96 110724 RK	R-5	Rural-5 Acre	Single Family Res-Combo
97 101013 RK	R-5	Rural-5 Acre	SFR-Basic
97 104177 RK	R-5	Rural-5 Acre	SFR-Basic
97 100057 RK	R-5	Rural-5 Acre	Single Family Res-Combo
96 109916 RK	R-5	Rural-5 Acre	Single Family Res-Combo
97 107158 RK	R-5	Rural-5 Acre	Single Family Res-Combo
97 105723 RK	R-5	Rural-5 Acre	SFR-Basic
97 105726 RK	R-5	Rural-5 Acre	SFR-Basic
97 100010 RK	R-5	Rural-5 Acre	SFR-Basic
97 105728 RK	R-5	Rural-5 Acre	SFR-Basic
97 102056 RK	R-5	Rural-5 Acre	Single Family Res-Combo
97 102649 RK	R-5	Rural-5 Acre	Single Family Res-Combo
97 103655 RK	R-5	Rural-5 Acre	Single Family Res-Combo
97 101288 RK	R-5	Rural-5 Acre	Single Family Res-Combo
97 101708 RK	R-5	Rural-5 Acre	SFR-Basic
96 107252 MH	R-5	Rural-5 Acre	Single Wide
96 107265 RK	MR	Multiple Residential	Duplex-Combo
97 103287 RK	R-5	Rural-5 Acre	Single Family Res-Combo
96 109865 RK	R-5	Rural-5 Acre	Single Family Res-Combo
97 101263 RK	R-5	Rural-5 Acre	Single Family Res-Combo
97 100877 RK	R-5	Rural-5 Acre	Single Family Res-Combo
97 102984 RK	R-5	Rural-5 Acre	Single Family Res-Combo
96 107170 MH	R-12,500	Residential 12,500 sq. ft.	Double Wide
96 110824 MH	R-5	Rural-5 Acre	Triple Wide
97 101931 RK	R-5	Rural-5 Acre	Single Family Res-Combo
97 100229 MH	R-5	Rural-5 Acre	Triple Wide
97 100677 RK	R-5	Rural-5 Acre	Single Family Res-Combo
97 100816 RK	R-9,600	Residential 9,600 sq. ft.	SFR-Basic
97 101063 RK	R-9,600	Residential 9,600 sq. ft.	Single Family Res-Combo
96 110665 RK	R-9,600	Residential 9,600 sq. ft.	Single Family Res-Combo
96 110876 RK	R-9,600	Residential 9,600 sq. ft.	Single Family Res-Combo
96 108944 RK	R-5	Rural-5 Acre	Single Family Res-Combo
97 108651 RK	R-5	Rural-5 Acre	Single Family Res-Combo
97 108655 RK	R-5	Rural-5 Acre	SFR-Basic
97 109347 RK	R-5	Rural-5 Acre	Single Family Res-Combo
97 105840 MH	R-5	Rural-5 Acre	Double Wide
97 102027 RK	PRD-7,200 : PF	Multiple Residential : Reside	SFR-Basic
97 102414 RK	R-5	Rural-5 Acre	Single Family Res-Combo
97 102413 RK	R-5	Rural-5 Acre	Single Family Res-Combo
97 105484 RK	R-5	Rural-5 Acre	SFR-Basic
97 102476 RK	R-5	Rural-5 Acre	Single Family Res-Combo
97 105487 RK	R-5	Rural-5 Acre	SFR-Basic
97 105494 RK	R-5	Rural-5 Acre	SFR-Basic

Accessory Dwelling Units

Index # - File Name: 1.0022 - Single Family Dwellings Data\_Snohomish County.pdf

97 107713 RK	R-5	Rural-5 Acre	Single Family Res-Combo
97 105495 RK	R-5	Rural-5 Acre	SFR-Basic
97 110704 RK	R-5	Rural-5 Acre	Single Family Res-Combo
97 104379 RK	R-5	Rural-5 Acre	SFR-Basic
97 111104 RK	R-5	Rural-5 Acre	Single Family Res-Combo
97 104761 MH	R-5	Rural-5 Acre	Triple Wide
97 104144 RK	R-5	Rural-5 Acre	Single Family Res-Combo
97 104443 RK	R-5	Rural-5 Acre	SFR-Basic
97 101515 RK	R-5	Rural-5 Acre	Single Family Res-Combo
97 102947 RK	R-5	Rural-5 Acre	Single Family Res-Combo
96 108349 RK	R-5	Rural-5 Acre	Single Family Res-Combo
97 108339 RK	R-5	Rural-5 Acre	Single Family Res-Combo
97 103285 MH	R-5	Rural-5 Acre	Double Wide
97 102280 RK	R-5	Rural-5 Acre	Single Family Res-Combo
97 109990 RK	R-5	Rural-5 Acre	Single Family Res-Combo
97 107286 RK	R-5	Rural-5 Acre	SFR-Basic
97 102189 RK	R-5	Rural-5 Acre	Single Family Res-Combo
97 107283 RK	R-5	Rural-5 Acre	SFR-Basic
97 102886 RK	R-5	Rural-5 Acre	SFR-Basic
97 100863 RK	R-5	Rural-5 Acre	Single Family Res-Combo
97 101414 RK	R-5	Rural-5 Acre	Single Family Res-Combo
97 101412 RK	R-5	Rural-5 Acre	Single Family Res-Combo
97 103353 RK	R-5	Rural-5 Acre	Single Family Res-Combo
97 104474 RK	R-5	Rural-5 Acre	Single Family Res-Combo
97 103948 RK	CITY	City	SFR-Basic
97 102421 RK	CITY	City	SFR-Basic
97 103551 RK	CITY	City	SFR-Basic
97 102417 RK	CITY	City	SFR-Basic
97 104324 RK	CITY	City	SFR-Basic
97 101652 RK	CITY	City	SFR-Basic
97 102814 RK	PRD-9,600	Residential 9,600 sq. ft.	SFR-Basic
97 105383 RK	PRD-9,600	Residential 9,600 sq. ft.	SFR-Basic
97 102816 RK	PRD-9,600	Residential 9,600 sq. ft.	Single Family Res-Combo
97 102818 RK	PRD-9,600	Residential 9,600 sq. ft.	Single Family Res-Combo
97 102948 RK	R-8,400	Residential 8,400 sq. ft.	Single Family Res-Combo
97 102817 RK	R-5	Rural-5 Acre	Single Family Res-Combo
97 108143 RK	R-5	Rural-5 Acre	Single Family Res-Combo
97 101627 RK	R-9,600	Residential 9,600 sq. ft.	Single Family Res-Combo
97 105170 MH	R-5	Rural-5 Acre	Single Wide
97 101984 RK	R-5	Rural-5 Acre	Single Family Res-Combo
97 102048 RK	R-5	Rural-5 Acre	Single Family Res-Combo
97 102834 RK	R-5	Rural-5 Acre	Single Family Res-Combo
97 108637 RK	R-5	Rural-5 Acre	Single Family Res-Combo
97 105059 RK	R-5	Rural-5 Acre	Single Family Res-Combo
97 110543 RK	R-5	Rural-5 Acre	SFR-Basic
97 108648 RK	R-5	Rural-5 Acre	Single Family Res-Combo
97 105608 RK	CITY	City	SFR-Basic

Accessory Dwelling Units

Index # - File Name: 1.0022 - Single Family Dwellings Data\_Snohomish County.pdf

97 109893 RK	CITY	City	SFR-Basic
97 105272 RK	CITY	City	SFR-Basic
97 105764 RK	CITY	City	Single Family Res-Combo
97 108777 RK	CITY	City	SFR-Basic
97 108776 RK	CITY	City	SFR-Basic
97 104396 RK	CITY	City	SFR-Basic
97 104397 RK	CITY	City	SFR-Basic
97 103162 RK	CITY	City	SFR-Basic
97 103160 RK	CITY	City	SFR-Basic
97 103161 RK	CITY	City	SFR-Basic
97 108127 RK	CITY	City	SFR-Basic
97 104399 RK	CITY	City	SFR-Basic
97 105607 RK	CITY	City	SFR-Basic
97 110295 RK	CITY	City	SFR-Basic
97 105271 RK	CITY	City	SFR-Basic
97 104849 RK	CITY	City	SFR-Basic
97 105612 RK	CITY	City	SFR-Basic
97 110294 RK	CITY	City	SFR-Basic
97 102737 RK	CITY	City	SFR-Basic
97 102733 RK	CITY	City	SFR-Basic
97 102736 RK	CITY	City	SFR-Basic
97 102738 RK	CITY	City	Single Family Res-Combo
97 104412 RK	CITY	City	SFR-Basic
97 103163 RK	CITY	City	SFR-Basic
97 105276 RK	CITY	City	SFR-Basic
97 105277 RK	CITY	City	SFR-Basic
97 108125 RK	CITY	City	SFR-Basic
97 102268 RK	CITY	City	Single Family Res-Combo
97 102043 RK	CITY	City	Duplex-Combo
97 102471 RK	R-5	Rural-5 Acre	Single Family Res-Combo
97 102457 MH	R-5	Rural-5 Acre	Double Wide
97 102517 RK	R-9,600	Residential 9,600 sq. ft.	SFR-Basic
97 102518 RK	R-9,600	Residential 9,600 sq. ft.	SFR-Basic
97 104875 RK	R-9,600	Residential 9,600 sq. ft.	SFR-Basic
97 104874 RK	R-9,600	Residential 9,600 sq. ft.	SFR-Basic
97 102677 RK	R-9,600	Residential 9,600 sq. ft.	SFR-Basic
97 102523 RK	R-9,600	Residential 9,600 sq. ft.	SFR-Basic
97 102519 RK	R-9,600	Residential 9,600 sq. ft.	SFR-Basic
97 102672 RK	R-9,600	Residential 9,600 sq. ft.	SFR-Basic
97 107972 RK	R-9,600	Residential 9,600 sq. ft.	SFR-Basic
97 102676 RK	R-9,600	Residential 9,600 sq. ft.	SFR-Basic
97 101371 RK	R-5	Rural-5 Acre	Single Family Res-Combo
97 101663 RK	R-5	Rural-5 Acre	Single Family Res-Combo
97 101692 RK	R-9,600	Residential 9,600 sq. ft.	Single Family Res-Combo
97 104325 RK	CITY	City	SFR-Basic
97 103949 RK	CITY	City	SFR-Basic
97 103952 RK	CITY	City	SFR-Basic



Accessory Dwelling Units

Index # - File Name: 1.0022 - Single Family Dwellings Data\_Snohomish County.pdf

97 103951 RK	CITY	City	SFR-Basic
97 103356 RK	CITY	City	Single Family Res-Combo
97 103547 RK	CITY	City	SFR-Basic
97 103354 RK	CITY	City	SFR-Basic
97 103137 RK	CITY	City	SFR-Basic
96 105101 RK	CITY	City	Single Family Res-Combo
97 101651 RK	CITY	City	SFR-Basic
97 101653 RK	CITY	City	SFR-Basic
97 101654 RK	CITY	City	SFR-Basic
97 104952 RK	CITY	City	SFR-Basic
97 103548 RK	CITY	City	SFR-Basic
97 103549 RK	CITY	City	SFR-Basic
97 102420 RK	CITY	City	SFR-Basic
97 103950 RK	CITY	City	SFR-Basic
97 103690 RK	R-7,200	Residential 7,200 sq. ft.	Single Family Res-Combo
97 103737 RK	R-7,200	Residential 7,200 sq. ft.	SFR-Basic
97 106265 RK	R-7,200	Residential 7,200 sq. ft.	Single Family Res-Combo
97 106304 RK	R-7,200	Residential 7,200 sq. ft.	SFR-Basic
97 105098 RK	R-7,200	Residential 7,200 sq. ft.	SFR-Basic
97 103500 RK	R-7,200	Residential 7,200 sq. ft.	SFR-Basic
97 103092 RK	R-7,200	Residential 7,200 sq. ft.	SFR-Basic
97 103771 RK	R-7,200	Residential 7,200 sq. ft.	SFR-Basic
97 106266 RK	R-7,200	Residential 7,200 sq. ft.	Single Family Res-Combo
97 105099 RK	R-7,200	Residential 7,200 sq. ft.	SFR-Basic
97 106860 RK	R-7,200	Residential 7,200 sq. ft.	SFR-Basic
97 108479 RK	R-7,200	Residential 7,200 sq. ft.	SFR-Basic
97 104677 RK	R-7,200	Residential 7,200 sq. ft.	SFR-Basic
97 110070 RK	R-7,200	Residential 7,200 sq. ft.	Single Family Res-Combo
97 107722 RK	R-7,200	Residential 7,200 sq. ft.	Single Family Res-Combo
97 106861 RK	R-7,200	Residential 7,200 sq. ft.	SFR-Basic
97 107723 RK	R-7,200	Residential 7,200 sq. ft.	SFR-Basic
97 109095 RK	R-7,200	Residential 7,200 sq. ft.	SFR-Basic
97 103768 RK	R-7,200	Residential 7,200 sq. ft.	SFR-Basic
97 103772 RK	R-7,200	Residential 7,200 sq. ft.	Single Family Res-Combo
97 104674 RK	R-7,200	Residential 7,200 sq. ft.	SFR-Basic
97 105699 RK	R-7,200	Residential 7,200 sq. ft.	SFR-Basic
97 106302 RK	R-7,200	Residential 7,200 sq. ft.	SFR-Basic
97 105742 RK	R-7,200	Residential 7,200 sq. ft.	SFR-Basic
97 109096 RK	R-7,200	Residential 7,200 sq. ft.	SFR-Basic
97 107724 RK	R-7,200	Residential 7,200 sq. ft.	SFR-Basic
97 105701 RK	R-7,200	Residential 7,200 sq. ft.	SFR-Basic
97 103769 RK	R-7,200	Residential 7,200 sq. ft.	SFR-Basic
97 110378 RK	R-7,200	Residential 7,200 sq. ft.	SFR-Basic
97 103632 RK	R-7,200	Residential 7,200 sq. ft.	Single Family Res-Combo
97 106862 RK	R-7,200	Residential 7,200 sq. ft.	SFR-Basic
97 103770 RK	R-7,200	Residential 7,200 sq. ft.	SFR-Basic
97 102943 RK	R-7,200	Residential 7,200 sq. ft.	SFR-Basic

Accessory Dwelling Units

Index # - File Name: 1.0022 - Single Family Dwellings Data\_Snohomish County.pdf

97 105740 RK	R-7,200	Residential 7,200 sq. ft.	Single Family Res-Combo
97 107625 RK	R-7,200	Residential 7,200 sq. ft.	Single Family Res-Combo
97 105095 RK	R-7,200	Residential 7,200 sq. ft.	SFR-Basic
97 102944 RK	R-7,200	Residential 7,200 sq. ft.	SFR-Basic
97 103501 RK	R-7,200	Residential 7,200 sq. ft.	SFR-Basic
96 109650 RK	R-7,200	Residential 7,200 sq. ft.	Single Family Res-Combo
97 103093 RK	R-7,200	Residential 7,200 sq. ft.	SFR-Basic
97 102945 RK	R-7,200	Residential 7,200 sq. ft.	SFR-Basic
97 102946 RK	R-7,200	Residential 7,200 sq. ft.	SFR-Basic
97 101879 RK	R-7,200	Residential 7,200 sq. ft.	Single Family Res-Combo
97 105033 RK	R-5	Rural-5 Acre	Single Family Res-Combo
97 100367 RK	CITY	City	Single Family Res-Combo
97 100370 RK	CITY	City	Single Family Res-Combo
97 100371 RK	CITY	City	Single Family Res-Combo
97 100372 RK	CITY	City	Single Family Res-Combo
97 105902 RK	CITY	City	SFR-Basic
97 106717 RK	CITY	City	SFR-Basic
97 104762 RK	CITY	City	SFR-Basic
97 104629 RK	CITY	City	SFR-Basic
97 104631 RK	CITY	City	SFR-Basic
97 100373 RK	CITY	City	Single Family Res-Combo
97 106711 RK	CITY	City	SFR-Basic
97 104815 RK	CITY	City	SFR-Basic
97 106712 RK	CITY	City	SFR-Basic
97 104816 RK	CITY	City	SFR-Basic
97 105905 RK	CITY	City	SFR-Basic
97 104817 RK	CITY	City	SFR-Basic
97 105904 RK	CITY	City	SFR-Basic
97 104814 RK	CITY	City	SFR-Basic
97 107528 RK	CITY	City	SFR-Basic
97 106710 RK	CITY	City	SFR-Basic
97 104811 RK	CITY	City	SFR-Basic
97 107530 RK	CITY	City	SFR-Basic
97 105903 RK	CITY	City	SFR-Basic
97 103043 RK	R-9,600	Residential 9,600 sq. ft.	Single Family Res-Combo
97 105937 RK	R-9,600	Residential 9,600 sq. ft.	SFR-Basic
97 101892 RK	R-9,600	Residential 9,600 sq. ft.	Single Family Res-Combo
97 105934 RK	R-9,600	Residential 9,600 sq. ft.	SFR-Basic
97 104978 RK	R-9,600	Residential 9,600 sq. ft.	SFR-Basic
97 106419 RK	R-9,600	Residential 9,600 sq. ft.	SFR-Basic
97 104980 RK	R-9,600	Residential 9,600 sq. ft.	SFR-Basic
97 106418 RK	R-9,600	Residential 9,600 sq. ft.	SFR-Basic
97 103044 RK	R-9,600	Residential 9,600 sq. ft.	Single Family Res-Combo
97 104635 RK	R-5	Rural-5 Acre	Single Family Res-Combo
97 102636 MH	R-5	Rural-5 Acre	Double Wide
97 103255 RK	R-5	Rural-5 Acre	Single Family Res-Combo
96 109408 RK	LDMR	Low Density Multiple Reside	Single Family Res-Combo

Accessory Dwelling Units

Index # - File Name: 1.0022 - Single Family Dwellings Data\_Snohomish County.pdf

97 103499 RK	LDMR	Low Density Multiple Reside	SFR-Basic
97 103679 RK	LDMR	Low Density Multiple Reside	SFR-Basic
97 100092 RK	LDMR	Low Density Multiple Reside	Single Family Res-Combo
97 107529 RK	CITY	City	SFR-Basic
97 107531 RK	CITY	City	SFR-Basic
97 100365 RK	CITY	City	Single Family Res-Combo
97 102734 RK	R-5	Rural-5 Acre	Single Family Res-Combo
97 103762 RK	R-5	Rural-5 Acre	Single Family Res-Combo
97 105340 RK	R-5	Rural-5 Acre	SFR-Basic
97 102876 RK	R-5	Rural-5 Acre	Single Family Res-Combo
96 106340 RK	R-5	Rural-5 Acre	Single Family Res-Combo
97 102904 RK	R-5	Rural-5 Acre	Single Family Res-Combo
97 102934 RK	R-5	Rural-5 Acre	Single Family Res-Combo
97 104336 RK	R-5	Rural-5 Acre	Single Family Res-Combo
97 102981 RK	R-5	Rural-5 Acre	Single Family Res-Combo
97 102979 RK	R-5	Rural-5 Acre	Single Family Res-Combo
97 100727 RK	R-5	Rural-5 Acre	Single Family Res-Combo
97 107230 RK	R-5	Rural-5 Acre	Single Family Res-Combo
97 102308 RK	R-5	Rural-5 Acre	Single Family Res-Combo
97 102967 MH	NB	Neighborhood Business	MH Park-Double Wide
97 103198 RK	R-5	Rural-5 Acre	Single Family Res-Combo
97 103237 MH	R-5	Rural-5 Acre	Double Wide
97 103276 RK	R-8,400	Residential 8,400 sq. ft.	Single Family Res-Combo
97 103306 MH	R-5	Rural-5 Acre	Double Wide
97 101519 RK	R-20,000	Residential 20,000 sq. ft.	Single Family Res-Combo
97 101525 RK	R-20,000	Residential 20,000 sq. ft.	Single Family Res-Combo
97 101526 RK	R-20,000	Residential 20,000 sq. ft.	Single Family Res-Combo
97 101522 RK	R-20,000	Residential 20,000 sq. ft.	Single Family Res-Combo
97 107290 RK	R-20,000	Residential 20,000 sq. ft.	Single Family Res-Combo
97 107293 RK	R-20,000	Residential 20,000 sq. ft.	Single Family Res-Combo
97 109809 RK	R-20,000	Residential 20,000 sq. ft.	SFR-Basic
97 109745 RK	R-20,000	Residential 20,000 sq. ft.	SFR-Basic
97 109751 RK	R-20,000	Residential 20,000 sq. ft.	SFR-Basic
97 109743 RK	R-20,000	Residential 20,000 sq. ft.	SFR-Basic
97 109755 RK	R-20,000	Residential 20,000 sq. ft.	SFR-Basic
97 109744 RK	R-20,000	Residential 20,000 sq. ft.	SFR-Basic
96 110927 RK	R-5	Rural-5 Acre	Single Family Res-Combo
97 104083 RK	R-5	Rural-5 Acre	SFR-Basic
96 110960 RK	R-5	Rural-5 Acre	Single Family Res-Combo
97 109504 RK	R-5	Rural-5 Acre	Single Family Res-Combo
96 110617 RK	R-5	Rural-5 Acre	Single Family Res-Combo
97 109505 RK	R-5	Rural-5 Acre	Single Family Res-Combo
97 107188 MH	R-5	Rural-5 Acre	Double Wide
97 100138 RK	R-5	Rural-5 Acre	Single Family Res-Combo
97 106599 RK	CITY	City	SFR-Basic
97 106600 RK	CITY	City	SFR-Basic
97 106601 RK	CITY	City	SFR-Basic

Accessory Dwelling Units

Index # - File Name: 1.0022 - Single Family Dwellings Data\_Snohomish County.pdf

97 106602 RK	CITY	City	SFR-Basic
97 106603 RK	CITY	City	SFR-Basic
97 106605 RK	CITY	City	SFR-Basic
97 106606 RK	CITY	City	SFR-Basic
97 106607 RK	CITY	City	SFR-Basic
97 106608 RK	CITY	City	SFR-Basic
97 106609 RK	CITY	City	SFR-Basic
97 106610 RK	CITY	City	SFR-Basic
97 106611 RK	CITY	City	SFR-Basic
97 100170 RK	CITY	City	SFR-Basic
97 100622 RK	CITY	City	SFR-Basic
97 100618 RK	CITY	City	SFR-Basic
97 100619 RK	CITY	City	SFR-Basic
97 100624 RK	CITY	City	SFR-Basic
97 100620 RK	CITY	City	SFR-Basic
97 100623 RK	CITY	City	SFR-Basic
97 100621 RK	CITY	City	SFR-Basic
97 100427 RK	R-5	Rural-5 Acre	Single Family Res-Combo
97 100376 RK	R-5	Rural-5 Acre	Duplex-Combo
97 105478 RK	R-5	Rural-5 Acre	SFR-Basic
97 102285 RK	CITY	City	Single Family Res-Combo
97 105395 RK	R-5	Rural-5 Acre	Single Family Res-Combo
97 107337 RK	R-5	Rural-5 Acre	Single Family Res-Combo
97 106839 RK	R-5	Rural-5 Acre	Single Family Res-Combo
97 104090 RK	R-5	Rural-5 Acre	Single Family Res-Combo
97 100405 RK	R-5	Rural-5 Acre	Single Family Res-Combo
96 105538 RK	PRD-9,600	Residential 9,600 sq. ft.	Single Family Res-Combo
96 105535 RK	PRD-9,600	Residential 9,600 sq. ft.	Single Family Res-Combo
96 106861 RK	PRD-9,600	Residential 9,600 sq. ft.	Single Family Res-Combo
96 105534 RK	PRD-9,600	Residential 9,600 sq. ft.	Single Family Res-Combo
97 100447 RK	A-10 : R-5	Agriculture-10 Acre : Rural-5	Single Family Res-Combo
96 110584 MH	R-5	Rural-5 Acre	Single Wide
97 101736 RK	R-5	Rural-5 Acre	Single Family Res-Combo
97 109339 RK	R-5	Rural-5 Acre	Single Family Res-Combo
97 100265 RK	R-5	Rural-5 Acre	SFR-Basic
97 104158 RK	CITY	City	Single Family Res-Combo
97 100703 RK	R-8,400	Residential 8,400 sq. ft.	SFR-Basic
96 110873 RK	R-8,400	Residential 8,400 sq. ft.	Single Family Res-Combo
97 100706 RK	R-8,400	Residential 8,400 sq. ft.	SFR-Basic
97 100710 RK	R-8,400	Residential 8,400 sq. ft.	SFR-Basic
96 110874 RK	R-8,400	Residential 8,400 sq. ft.	Single Family Res-Combo
97 107772 RK	R-8,400	Residential 8,400 sq. ft.	SFR-Basic
97 107774 RK	R-8,400	Residential 8,400 sq. ft.	Single Family Res-Combo
97 100705 RK	R-8,400	Residential 8,400 sq. ft.	SFR-Basic
97 101417 RK	R-8,400	Residential 8,400 sq. ft.	SFR-Basic
97 102040 RK	R-8,400	Residential 8,400 sq. ft.	SFR-Basic
97 100702 RK	R-8,400	Residential 8,400 sq. ft.	SFR-Basic

Accessory Dwelling Units

Index # - File Name: 1.0022 - Single Family Dwellings Data\_Snohomish County.pdf

96 110875 RK	R-8,400	Residential 8,400 sq. ft.	Single Family Res-Combo
97 100434 RK	R-8,400	Residential 8,400 sq. ft.	Single Family Res-Combo
97 102295 RK	R-8,400	Residential 8,400 sq. ft.	SFR-Basic
96 110870 RK	R-8,400	Residential 8,400 sq. ft.	Single Family Res-Combo
97 106345 RK	PRD-9,600	Residential 9,600 sq. ft.	SFR-Basic
97 106346 RK	PRD-9,600	Residential 9,600 sq. ft.	SFR-Basic
97 105702 RK	PRD-9,600	Residential 9,600 sq. ft.	SFR-Basic
97 106347 RK	PRD-9,600	Residential 9,600 sq. ft.	SFR-Basic
97 105704 RK	PRD-9,600	Residential 9,600 sq. ft.	SFR-Basic
97 106348 RK	PRD-9,600	Residential 9,600 sq. ft.	SFR-Basic
97 104329 RK	PRD-9,600	Residential 9,600 sq. ft.	SFR-Basic
97 104009 RK	PRD-9,600	Residential 9,600 sq. ft.	SFR-Basic
97 104011 RK	PRD-9,600	Residential 9,600 sq. ft.	SFR-Basic
97 104012 RK	PRD-9,600	Residential 9,600 sq. ft.	SFR-Basic
97 105049 RK	PRD-9,600	Residential 9,600 sq. ft.	SFR-Basic
97 104014 RK	PRD-9,600	Residential 9,600 sq. ft.	SFR-Basic
97 103601 RK	PRD-9,600	Residential 9,600 sq. ft.	Single Family Res-Combo
97 104835 RK	PRD-9,600	Residential 9,600 sq. ft.	SFR-Basic
97 104827 RK	PRD-9,600	Residential 9,600 sq. ft.	SFR-Basic
97 103599 RK	PRD-9,600	Residential 9,600 sq. ft.	Single Family Res-Combo
97 100454 RK	PRD-9,600	Residential 9,600 sq. ft.	Single Family Res-Combo
97 103603 RK	PRD-9,600	Residential 9,600 sq. ft.	Single Family Res-Combo
97 104833 RK	PRD-9,600	Residential 9,600 sq. ft.	SFR-Basic
97 104840 RK	PRD-9,600	Residential 9,600 sq. ft.	SFR-Basic
97 104838 RK	PRD-9,600	Residential 9,600 sq. ft.	SFR-Basic
97 104839 RK	PRD-9,600	Residential 9,600 sq. ft.	SFR-Basic
97 105445 RK	PRD-9,600	Residential 9,600 sq. ft.	SFR-Basic
97 104560 RK	PRD-9,600	Residential 9,600 sq. ft.	SFR-Basic
97 104826 RK	PRD-9,600	Residential 9,600 sq. ft.	SFR-Basic
97 104557 RK	PRD-9,600	Residential 9,600 sq. ft.	SFR-Basic
97 104837 RK	PRD-9,600	Residential 9,600 sq. ft.	SFR-Basic
97 104825 RK	PRD-9,600	Residential 9,600 sq. ft.	SFR-Basic
97 104836 RK	PRD-9,600	Residential 9,600 sq. ft.	SFR-Basic
97 104435 RK	PRD-9,600	Residential 9,600 sq. ft.	SFR-Basic
97 104433 RK	PRD-9,600	Residential 9,600 sq. ft.	SFR-Basic
97 102959 RK	PRD-9,600	Residential 9,600 sq. ft.	SFR-Basic
97 102961 RK	PRD-9,600	Residential 9,600 sq. ft.	SFR-Basic
97 102962 RK	PRD-9,600	Residential 9,600 sq. ft.	SFR-Basic
97 102963 RK	PRD-9,600	Residential 9,600 sq. ft.	SFR-Basic
97 102964 RK	PRD-9,600	Residential 9,600 sq. ft.	SFR-Basic
97 102966 RK	PRD-9,600	Residential 9,600 sq. ft.	SFR-Basic
97 102968 RK	PRD-9,600	Residential 9,600 sq. ft.	SFR-Basic
97 102969 RK	PRD-9,600	Residential 9,600 sq. ft.	SFR-Basic
97 103602 RK	PRD-9,600	Residential 9,600 sq. ft.	SFR-Basic
97 103558 RK	PRD-9,600	Residential 9,600 sq. ft.	SFR-Basic
97 104828 RK	PRD-9,600	Residential 9,600 sq. ft.	SFR-Basic
97 106551 RK	PRD-9,600	Residential 9,600 sq. ft.	SFR-Basic

Accessory Dwelling Units

Index # - File Name: 1.0022 - Single Family Dwellings Data\_Snohomish County.pdf

97 105921 RK	PRD-9,600	Residential 9,600 sq. ft.	SFR-Basic
97 105046 RK	PRD-9,600	Residential 9,600 sq. ft.	SFR-Basic
97 106547 RK	PRD-9,600	Residential 9,600 sq. ft.	SFR-Basic
97 102431 RK	PRD-9,600	Residential 9,600 sq. ft.	SFR-Basic
97 102432 RK	PRD-9,600	Residential 9,600 sq. ft.	SFR-Basic
97 102434 RK	PRD-9,600	Residential 9,600 sq. ft.	SFR-Basic
97 102435 RK	PRD-9,600	Residential 9,600 sq. ft.	SFR-Basic
97 102436 RK	PRD-9,600	Residential 9,600 sq. ft.	SFR-Basic
97 102174 RK	PRD-9,600	Residential 9,600 sq. ft.	SFR-Basic
97 102176 RK	PRD-9,600	Residential 9,600 sq. ft.	SFR-Basic
97 102177 RK	PRD-9,600	Residential 9,600 sq. ft.	SFR-Basic
97 102178 RK	PRD-9,600	Residential 9,600 sq. ft.	SFR-Basic
97 102179 RK	PRD-9,600	Residential 9,600 sq. ft.	SFR-Basic
97 102180 RK	PRD-9,600	Residential 9,600 sq. ft.	SFR-Basic
97 101269 RK	PRD-9,600	Residential 9,600 sq. ft.	SFR-Basic
97 101270 RK	PRD-9,600	Residential 9,600 sq. ft.	SFR-Basic
97 101271 RK	PRD-9,600	Residential 9,600 sq. ft.	SFR-Basic
97 101272 RK	PRD-9,600	Residential 9,600 sq. ft.	SFR-Basic
97 101273 RK	PRD-9,600	Residential 9,600 sq. ft.	SFR-Basic
97 101277 RK	PRD-9,600	Residential 9,600 sq. ft.	SFR-Basic
97 101278 RK	PRD-9,600	Residential 9,600 sq. ft.	SFR-Basic
97 101279 RK	PRD-9,600	Residential 9,600 sq. ft.	SFR-Basic
97 101047 RK	PRD-9,600	Residential 9,600 sq. ft.	SFR-Basic
97 101048 RK	PRD-9,600	Residential 9,600 sq. ft.	SFR-Basic
97 101042 RK	PRD-9,600	Residential 9,600 sq. ft.	SFR-Basic
97 101043 RK	PRD-9,600	Residential 9,600 sq. ft.	SFR-Basic
97 101044 RK	PRD-9,600	Residential 9,600 sq. ft.	SFR-Basic
97 101046 RK	PRD-9,600	Residential 9,600 sq. ft.	SFR-Basic
97 100858 RK	PRD-9,600	Residential 9,600 sq. ft.	SFR-Basic
97 100855 RK	PRD-9,600	Residential 9,600 sq. ft.	SFR-Basic
97 100856 RK	PRD-9,600	Residential 9,600 sq. ft.	SFR-Basic
97 100859 RK	PRD-9,600	Residential 9,600 sq. ft.	SFR-Basic
97 100860 RK	PRD-9,600	Residential 9,600 sq. ft.	SFR-Basic
97 100861 RK	PRD-9,600	Residential 9,600 sq. ft.	SFR-Basic
97 101116 RK	A-10 : R-9,600	Agriculture-10 Acre : Residential Single Family Res-Combo	
97 101258 RK	CITY	City	SFR-Basic
97 101259 RK	CITY	City	SFR-Basic
97 102558 RK	CITY	City	SFR-Basic
97 102560 RK	CITY	City	SFR-Basic
97 101617 RK	CITY	City	SFR-Basic
97 101618 RK	CITY	City	SFR-Basic
97 102691 RK	CITY	City	SFR-Basic
97 102692 RK	CITY	City	SFR-Basic
97 101851 RK	CITY	City	SFR-Basic
97 101854 RK	CITY	City	SFR-Basic
97 102561 RK	CITY	City	SFR-Basic
97 102562 RK	CITY	City	SFR-Basic

Accessory Dwelling Units

Index # - File Name: 1.0022 - Single Family Dwellings Data\_Snohomish County.pdf

97 101620 RK	CITY	City	SFR-Basic
96 110067 RK	CITY	City	Single Family Res-Combo
97 102685 RK	CITY	City	SFR-Basic
97 102684 RK	CITY	City	SFR-Basic
97 102145 RK	CITY	City	SFR-Basic
97 102146 RK	CITY	City	SFR-Basic
97 102698 RK	CITY	City	SFR-Basic
97 102699 RK	CITY	City	SFR-Basic
97 102707 RK	CITY	City	SFR-Basic
97 102708 RK	CITY	City	SFR-Basic
97 102147 RK	CITY	City	SFR-Basic
97 102148 RK	CITY	City	SFR-Basic
97 102695 RK	CITY	City	SFR-Basic
97 102696 RK	CITY	City	SFR-Basic
97 102700 RK	CITY	City	SFR-Basic
97 102701 RK	CITY	City	SFR-Basic
97 101853 RK	CITY	City	SFR-Basic
97 101852 RK	CITY	City	SFR-Basic
97 102703 RK	CITY	City	SFR-Basic
97 102704 RK	CITY	City	SFR-Basic
97 101260 RK	CITY	City	SFR-Basic
97 101261 RK	CITY	City	SFR-Basic
97 104639 RK	F	Forestry	Single Family Res-Combo
97 100579 RK	R-5	Rural-5 Acre	Single Family Res-Combo
97 100660 MH	R-5	Rural-5 Acre	Double Wide
97 100648 RK	R-5	Rural-5 Acre	Single Family Res-Combo
97 106943 MH	R-5	Rural-5 Acre	Double Wide
97 110866 RK	R-5	Rural-5 Acre	SFR-Basic
97 101082 RK	CITY	City	Duplex-Combo
97 101080 RK	CITY	City	Duplex-Combo
97 100744 RK	R-5	Rural-5 Acre	Single Family Res-Combo
97 104188 RK	R-5	Rural-5 Acre	Single Family Res-Combo
97 105396 RK	R-5	Rural-5 Acre	Single Family Res-Combo
97 101083 MH	R-5	Rural-5 Acre	Double Wide
97 102786 RK	PRD-9,600	Residential 9,600 sq. ft.	SFR-Basic
97 102787 RK	PRD-9,600	Residential 9,600 sq. ft.	SFR-Basic
97 105037 RK	PRD-9,600	Residential 9,600 sq. ft.	SFR-Basic
97 105038 RK	PRD-9,600	Residential 9,600 sq. ft.	SFR-Basic
96 105510 RK	PRD-9,600	Residential 9,600 sq. ft.	Single Family Res-Combo
96 110887 RK	PRD-9,600	Residential 9,600 sq. ft.	Single Family Res-Combo
97 101213 RK	PRD-9,600	Residential 9,600 sq. ft.	SFR-Basic
96 105537 RK	PRD-9,600	Residential 9,600 sq. ft.	Single Family Res-Combo
97 101530 RK	PRD-9,600	Residential 9,600 sq. ft.	SFR-Basic
97 107062 RK	PRD-9,600	Residential 9,600 sq. ft.	SFR-Basic
97 107064 RK	PRD-9,600	Residential 9,600 sq. ft.	SFR-Basic
97 103740 RK	PRD-9,600	Residential 9,600 sq. ft.	SFR-Basic
97 107067 RK	PRD-9,600	Residential 9,600 sq. ft.	SFR-Basic

Accessory Dwelling Units

Index # - File Name: 1.0022 - Single Family Dwellings Data\_Snohomish County.pdf

97 107070 RK	PRD-9,600	Residential 9,600 sq. ft.	SFR-Basic
97 103741 RK	PRD-9,600	Residential 9,600 sq. ft.	SFR-Basic
97 109707 RK	PRD-9,600	Residential 9,600 sq. ft.	SFR-Basic
97 106218 RK	PRD-9,600	Residential 9,600 sq. ft.	Single Family Res-Combo
97 106226 RK	PRD-9,600	Residential 9,600 sq. ft.	Single Family Res-Combo
97 106252 RK	PRD-9,600	Residential 9,600 sq. ft.	SFR-Basic
97 106224 RK	PRD-9,600	Residential 9,600 sq. ft.	Single Family Res-Combo
97 106253 RK	PRD-9,600	Residential 9,600 sq. ft.	SFR-Basic
97 106220 RK	PRD-9,600	Residential 9,600 sq. ft.	Single Family Res-Combo
97 106222 RK	PRD-9,600	Residential 9,600 sq. ft.	Single Family Res-Combo
97 106221 RK	PRD-9,600	Residential 9,600 sq. ft.	Single Family Res-Combo
97 100617 RK	PRD-9,600	Residential 9,600 sq. ft.	Single Family Res-Combo
96 105531 RK	PRD-9,600	Residential 9,600 sq. ft.	Single Family Res-Combo
96 105530 RK	PRD-9,600	Residential 9,600 sq. ft.	Single Family Res-Combo
97 102788 RK	PRD-9,600	Residential 9,600 sq. ft.	SFR-Basic
97 107075 RK	PRD-9,600	Residential 9,600 sq. ft.	SFR-Basic
97 105035 RK	PRD-9,600	Residential 9,600 sq. ft.	SFR-Basic
97 109709 RK	PRD-9,600	Residential 9,600 sq. ft.	SFR-Basic
97 109711 RK	PRD-9,600	Residential 9,600 sq. ft.	SFR-Basic
97 101214 RK	PRD-9,600	Residential 9,600 sq. ft.	SFR-Basic
97 101216 RK	PRD-9,600	Residential 9,600 sq. ft.	SFR-Basic
97 100748 RK	R-9,600	Residential 9,600 sq. ft.	Single Family Res-Combo
97 100750 RK	R-9,600	Residential 9,600 sq. ft.	Single Family Res-Combo
97 102135 RK	R-9,600	Residential 9,600 sq. ft.	Single Family Res-Combo
97 102129 RK	R-9,600	Residential 9,600 sq. ft.	Single Family Res-Combo
97 101228 RK	R-5	Rural-5 Acre	Single Family Res-Combo
97 100831 RK	CITY	City	Single Family Res-Combo
97 101896 MH	R-5	Rural-5 Acre	Double Wide
97 108926 RK	R-5	Rural-5 Acre	Single Family Res-Combo
97 101221 MH	R-5	Rural-5 Acre	Triple Wide
96 110464 RK	R-8,400	Residential 8,400 sq. ft.	Single Family Res-Combo
96 110466 RK	R-8,400	Residential 8,400 sq. ft.	Single Family Res-Combo
96 110467 RK	R-8,400	Residential 8,400 sq. ft.	Single Family Res-Combo
97 101322 MH	MHP	Mobile Home Park	MH Park-Double Wide
97 106034 RK	R-5	Rural-5 Acre	SFR-Basic
97 110553 MH	R-5	Rural-5 Acre	Single Wide
97 101418 RK	CITY	City	SFR-Basic
97 101419 RK	CITY	City	SFR-Basic
97 101420 RK	CITY	City	SFR-Basic
97 101422 RK	CITY	City	SFR-Basic
97 101423 RK	CITY	City	SFR-Basic
97 101424 RK	CITY	City	SFR-Basic
97 101425 RK	CITY	City	SFR-Basic
97 101426 RK	CITY	City	SFR-Basic
97 101428 RK	CITY	City	SFR-Basic
97 101430 RK	CITY	City	SFR-Basic
97 101431 RK	CITY	City	SFR-Basic



Accessory Dwelling Units

Index # - File Name: 1.0022 - Single Family Dwellings Data\_Snohomish County.pdf

97 102320 RK	CITY	City	SFR-Basic
97 101432 RK	CITY	City	SFR-Basic
97 100827 RK	CITY	City	Single Family Res-Combo
97 100824 RK	CITY	City	Single Family Res-Combo
97 103250 RK	CITY	City	SFR-Basic
97 103252 RK	CITY	City	SFR-Basic
97 103253 RK	CITY	City	SFR-Basic
97 104544 RK	CITY	City	SFR-Basic
97 104542 RK	CITY	City	SFR-Basic
97 105490 RK	CITY	City	SFR-Basic
97 105492 RK	CITY	City	SFR-Basic
97 104545 RK	CITY	City	SFR-Basic
97 103249 RK	CITY	City	SFR-Basic
97 103248 RK	CITY	City	SFR-Basic
97 103246 RK	CITY	City	SFR-Basic
97 105491 RK	CITY	City	SFR-Basic
97 106356 RK	R-5	Rural-5 Acre	SFR-Basic
97 101503 MH	RD	Rural Diversification	Double Wide
97 101523 MH	R-12,500	Residential 12,500 sq. ft.	Double Wide
97 101528 MH	R-5	Rural-5 Acre	Double Wide
97 110337 MH	R-5	Rural-5 Acre	Double Wide
97 102669 RK	R-5	Rural-5 Acre	Single Family Res-Combo
97 104361 MH	R-5	Rural-5 Acre	Single Wide
97 100752 RK	R-5	Rural-5 Acre	Single Family Res-Combo
97 101007 RK	R-5	Rural-5 Acre	Single Family Res-Combo
97 103605 RK	R-5	Rural-5 Acre	SFR-Basic
97 102693 RK	R-5	Rural-5 Acre	Single Family Res-Combo
97 100869 RK	R-5	Rural-5 Acre	Single Family Res-Combo
97 104645 RK	R-5	Rural-5 Acre	Single Family Res-Combo
97 103053 MH	F	Forestry	Double Wide
96 108061 RK	R-5	Rural-5 Acre	Single Family Res-Combo
97 106390 RK	CITY	City	Single Family Res-Combo
97 102034 RK	PRD-9,600	Residential 9,600 sq. ft.	SFR-Basic
97 102035 RK	PRD-9,600	Residential 9,600 sq. ft.	SFR-Basic
97 104401 RK	PRD-9,600	Residential 9,600 sq. ft.	SFR-Basic
97 104402 RK	PRD-9,600	Residential 9,600 sq. ft.	SFR-Basic
97 104404 RK	PRD-9,600	Residential 9,600 sq. ft.	SFR-Basic
97 104405 RK	PRD-9,600	Residential 9,600 sq. ft.	SFR-Basic
97 104406 RK	PRD-9,600	Residential 9,600 sq. ft.	SFR-Basic
97 104407 RK	PRD-9,600	Residential 9,600 sq. ft.	SFR-Basic
97 106284 RK	PRD-9,600	Residential 9,600 sq. ft.	SFR-Basic
97 106285 RK	PRD-9,600	Residential 9,600 sq. ft.	SFR-Basic
97 106288 RK	PRD-9,600	Residential 9,600 sq. ft.	SFR-Basic
97 106289 RK	PRD-9,600	Residential 9,600 sq. ft.	SFR-Basic
97 106290 RK	PRD-9,600	Residential 9,600 sq. ft.	SFR-Basic
97 106291 RK	PRD-9,600	Residential 9,600 sq. ft.	SFR-Basic
97 101680 RK	PRD-9,600	Residential 9,600 sq. ft.	SFR-Basic

Accessory Dwelling Units

Index # - File Name: 1.0022 - Single Family Dwellings Data\_Snohomish County.pdf

97 101682 RK	PRD-9,600	Residential 9,600 sq. ft.	SFR-Basic
97 102032 RK	PRD-9,600	Residential 9,600 sq. ft.	SFR-Basic
97 101683 RK	PRD-9,600	Residential 9,600 sq. ft.	SFR-Basic
97 101684 RK	PRD-9,600	Residential 9,600 sq. ft.	SFR-Basic
97 106279 RK	PRD-9,600	Residential 9,600 sq. ft.	SFR-Basic
97 106281 RK	PRD-9,600	Residential 9,600 sq. ft.	SFR-Basic
97 106282 RK	PRD-9,600	Residential 9,600 sq. ft.	SFR-Basic
97 106283 RK	PRD-9,600	Residential 9,600 sq. ft.	SFR-Basic
97 100514 RK	R-5	Rural-5 Acre	Single Family Res-Combo
97 107536 RK	R-5	Rural-5 Acre	Single Family Res-Combo
97 103670 RK	R-5	Rural-5 Acre	Single Family Res-Combo
97 105346 RK	R-9,600	Residential 9,600 sq. ft.	Single Family Res-Combo
97 102469 RK	R-9,600	Residential 9,600 sq. ft.	Single Family Res-Combo
97 100652 RK	R-9,600	Residential 9,600 sq. ft.	Single Family Res-Combo
97 104859 RK	R-9,600	Residential 9,600 sq. ft.	Single Family Res-Combo
97 102467 RK	R-9,600	Residential 9,600 sq. ft.	Single Family Res-Combo
97 101205 RK	R-9,600	Residential 9,600 sq. ft.	SFR-Basic
97 105063 RK	R-9,600	Residential 9,600 sq. ft.	Single Family Res-Combo
97 105062 RK	R-9,600	Residential 9,600 sq. ft.	Single Family Res-Combo
97 104855 RK	R-9,600	Residential 9,600 sq. ft.	Single Family Res-Combo
97 105808 RK	R-9,600	Residential 9,600 sq. ft.	SFR-Basic
97 103349 RK	R-9,600	Residential 9,600 sq. ft.	Single Family Res-Combo
97 101687 RK	R-9,600	Residential 9,600 sq. ft.	SFR-Basic
97 104509 RK	R-9,600	Residential 9,600 sq. ft.	Single Family Res-Combo
97 108872 RK	R-9,600	Residential 9,600 sq. ft.	Single Family Res-Combo
97 107559 RK	R-9,600	Residential 9,600 sq. ft.	SFR-Basic
97 100303 RK	R-9,600	Residential 9,600 sq. ft.	SFR-Basic
97 100633 MH	RRT-10	Rural Resource Transition-10	Double Wide
94 140456 000 01 RK	R-5	Rural-5 Acre	Single Family Res-Combo
96 110893 RK	R-5	Rural-5 Acre	SFR-Basic
97 102498 RK	R-5	Rural-5 Acre	Single Family Res-Combo
97 105054 RK	R-5	Rural-5 Acre	Single Family Res-Combo
97 105053 RK	R-5	Rural-5 Acre	Single Family Res-Combo
97 101587 RK	PRD-9,600	Residential 9,600 sq. ft.	SFR-Basic
94 140795 000 01 RK	R-5	Rural-5 Acre	Single Family Res-Combo
96 106221 RK	R-9,600	Residential 9,600 sq. ft.	Single Family Res-Combo
97 108487 RK	R-9,600	Residential 9,600 sq. ft.	Single Family Res-Combo
94 140272 000 01 RK	R-5	Rural-5 Acre	Single Family Res-Combo
97 101585 MH	F : RD	Forestry : Rural Diversificatio	Double Wide
97 102839 RK	F	Forestry	Single Family Res-Combo
97 101588 RK	PRD-9,600	Residential 9,600 sq. ft.	SFR-Basic
97 101593 RK	PRD-9,600	Residential 9,600 sq. ft.	SFR-Basic
97 103564 RK	PRD-9,600	Residential 9,600 sq. ft.	SFR-Basic
97 101592 RK	PRD-9,600	Residential 9,600 sq. ft.	SFR-Basic
97 102429 RK	PRD-9,600	Residential 9,600 sq. ft.	SFR-Basic
97 101490 RK	PRD-9,600	Residential 9,600 sq. ft.	SFR-Basic
97 102170 RK	PRD-9,600	Residential 9,600 sq. ft.	SFR-Basic

Accessory Dwelling Units

Index # - File Name: 1.0022 - Single Family Dwellings Data\_Snohomish County.pdf

96 110895 RK	PRD-9,600	Residential 9,600 sq. ft.	SFR-Basic
97 101590 RK	PRD-9,600	Residential 9,600 sq. ft.	SFR-Basic
97 103560 RK	PRD-9,600	Residential 9,600 sq. ft.	SFR-Basic
97 103600 RK	PRD-9,600	Residential 9,600 sq. ft.	Single Family Res-Combo
97 103562 RK	PRD-9,600	Residential 9,600 sq. ft.	SFR-Basic
97 101905 RK	PRD-9,600	Residential 9,600 sq. ft.	SFR-Basic
97 100964 RK	PRD SA-1	Suburban Agriculture-1 Acre	Single Family Res-Combo
97 102068 RK	PRD SA-1	Suburban Agriculture-1 Acre	SFR-Basic
97 107757 RK	PRD SA-1	Suburban Agriculture-1 Acre	SFR-Basic
97 104360 RK	PRD-9,600	Residential 9,600 sq. ft.	SFR-Basic
97 107562 RK	PRD-9,600	Residential 9,600 sq. ft.	SFR-Basic
97 104861 RK	PRD-9,600	Residential 9,600 sq. ft.	SFR-Basic
97 108673 RK	PRD-9,600	Residential 9,600 sq. ft.	Single Family Res-Combo
97 102777 RK	PRD-9,600	Residential 9,600 sq. ft.	Single Family Res-Combo
97 106177 RK	PRD-9,600	Residential 9,600 sq. ft.	Single Family Res-Combo
97 104804 RK	CITY	City	Single Family Res-Combo
97 111252 RK	PRD-9,600	Residential 9,600 sq. ft.	SFR-Basic
97 106575 RK	PRD-9,600	Residential 9,600 sq. ft.	SFR-Basic
97 111175 RK	PRD-9,600	Residential 9,600 sq. ft.	SFR-Basic
97 100658 RK	PRD-9,600	Residential 9,600 sq. ft.	SFR-Basic
97 102277 RK	PRD-9,600	Residential 9,600 sq. ft.	Single Family Res-Combo
97 102273 RK	PRD-9,600	Residential 9,600 sq. ft.	SFR-Basic
97 100657 RK	PRD-9,600	Residential 9,600 sq. ft.	SFR-Basic
97 100478 RK	PRD-9,600	Residential 9,600 sq. ft.	Single Family Res-Combo
97 100656 RK	PRD-9,600	Residential 9,600 sq. ft.	SFR-Basic
97 104902 RK	R-5	Rural-5 Acre	Single Family Res-Combo
96 110573 RK	R-5	Rural-5 Acre	Single Family Res-Combo
96 106986 RK	R-5	Rural-5 Acre	Single Family Res-Combo
97 100469 RK	PRD-9,600	Residential 9,600 sq. ft.	Single Family Res-Combo
97 103709 RK	R-9,600	Residential 9,600 sq. ft.	Single Family Res-Combo
96 109569 MH	F	Forestry	Double Wide
97 102974 RK	R-5	Rural-5 Acre	Single Family Res-Combo
97 106526 RK	R-5	Rural-5 Acre	Single Family Res-Combo
96 108849 RK	R-5	Rural-5 Acre	Single Family Res-Combo
97 109106 RK	R-5	Rural-5 Acre	Single Family Res-Combo
97 107235 MH	R-5	Rural-5 Acre	Double Wide
97 108503 RK	R-7,200 : R-9,600	Residential 7,200 sq. ft.	Single Family Res-Combo
97 108500 RK	R-7,200 : R-9,600	Residential 7,200 sq. ft.	Single Family Res-Combo
97 108822 RK	R-9,600	Residential 9,600 sq. ft.	Single Family Res-Combo
97 109554 RK	R-9,600	Residential 9,600 sq. ft.	SFR-Basic
97 103395 RK	R-5	Rural-5 Acre	Single Family Res-Combo
97 108820 RK	R-5	Rural-5 Acre	Single Family Res-Combo
97 105569 RK	RC	Rural Conservation	Single Family Res-Combo
97 101242 MH	R-5	Rural-5 Acre	Double Wide
97 109778 MH	R-5	Rural-5 Acre	Double Wide
96 109131 RK	R-5	Rural-5 Acre	Single Family Res-Combo
97 105767 RK	R-5	Rural-5 Acre	Single Family Res-Combo

Accessory Dwelling Units

Index # - File Name: 1.0022 - Single Family Dwellings Data\_Snohomish County.pdf

96 109091 RK	R-5	Rural-5 Acre	Single Family Res-Combo
97 106228 RK	LDMR	Low Density Multiple Reside	Single Family Res-Combo
97 103684 RK	R-8,400	Residential 8,400 sq. ft.	Single Family Res-Combo
97 103582 RK	R-8,400	Residential 8,400 sq. ft.	Single Family Res-Combo
97 110734 RK	R-8,400	Residential 8,400 sq. ft.	Single Family Res-Combo
97 110735 RK	R-8,400	Residential 8,400 sq. ft.	Single Family Res-Combo
97 109552 RK	R-8,400	Residential 8,400 sq. ft.	SFR-Basic
97 109462 RK	R-9,600	Residential 9,600 sq. ft.	Single Family Res-Combo
97 109664 RK	R-8,400 : R-9,600	Residential 8,400 sq. ft. : Res	SFR-Basic
97 108764 RK	R-8,400	Residential 8,400 sq. ft.	Single Family Res-Combo
97 109228 RK	R-8,400	Residential 8,400 sq. ft.	Single Family Res-Combo
97 110323 RK	R-8,400	Residential 8,400 sq. ft.	SFR-Basic
97 110320 RK	R-8,400	Residential 8,400 sq. ft.	SFR-Basic
96 110420 RK	R-8,400	Residential 8,400 sq. ft.	Single Family Res-Combo
96 110417 RK	R-8,400	Residential 8,400 sq. ft.	Single Family Res-Combo
97 100712 RK	R-8,400	Residential 8,400 sq. ft.	Single Family Res-Combo
96 110203 RK	R-8,400	Residential 8,400 sq. ft.	Single Family Res-Combo
97 100711 RK	R-8,400	Residential 8,400 sq. ft.	Single Family Res-Combo
97 103686 RK	R-8,400	Residential 8,400 sq. ft.	SFR-Basic
96 110419 RK	R-8,400	Residential 8,400 sq. ft.	Single Family Res-Combo
97 110321 RK	R-8,400	Residential 8,400 sq. ft.	SFR-Basic
97 110325 RK	R-8,400	Residential 8,400 sq. ft.	SFR-Basic
97 110319 RK	R-8,400	Residential 8,400 sq. ft.	SFR-Basic
97 103800 RK	R-8,400	Residential 8,400 sq. ft.	Single Family Res-Combo
97 109546 RK	R-8,400	Residential 8,400 sq. ft.	SFR-Basic
97 109550 RK	R-8,400	Residential 8,400 sq. ft.	SFR-Basic
97 103802 RK	R-8,400	Residential 8,400 sq. ft.	Single Family Res-Combo
97 103803 RK	R-8,400	Residential 8,400 sq. ft.	Single Family Res-Combo
97 110828 RK	R-8,400	Residential 8,400 sq. ft.	Single Family Res-Combo
97 110093 RK	R-8,400	Residential 8,400 sq. ft.	Single Family Res-Combo
96 110807 RK	R-8,400	Residential 8,400 sq. ft.	Single Family Res-Combo
97 103576 RK	R-8,400	Residential 8,400 sq. ft.	Single Family Res-Combo
97 103681 RK	R-8,400	Residential 8,400 sq. ft.	Single Family Res-Combo
97 103682 RK	R-8,400	Residential 8,400 sq. ft.	Single Family Res-Combo
97 103578 RK	R-8,400	Residential 8,400 sq. ft.	Single Family Res-Combo
97 110177 RK	R-8,400	Residential 8,400 sq. ft.	Single Family Res-Combo
96 110805 RK	R-9,600	Residential 9,600 sq. ft.	SFR-Basic
97 100309 RK	R-9,600	Residential 9,600 sq. ft.	Single Family Res-Combo
97 100305 RK	R-9,600	Residential 9,600 sq. ft.	SFR-Basic
97 106413 RK	LDMR	Low Density Multiple Reside	Duplex-Combo
97 106721 RK	R-5	Rural-5 Acre	Single Family Res-Combo
96 110204 RK	R-9,600	Residential 9,600 sq. ft.	Single Family Res-Combo
97 102433 RK	PRD-9,600	Residential 9,600 sq. ft.	Single Family Res-Combo
97 102055 RK	PRD-9,600	Residential 9,600 sq. ft.	Single Family Res-Combo
97 100472 RK	PRD-9,600	Residential 9,600 sq. ft.	Single Family Res-Combo
97 100399 RK	PRD-9,600	Residential 9,600 sq. ft.	SFR-Basic
95 104703 RK	PRD-9,600	Residential 9,600 sq. ft.	Single Family Res-Combo

Accessory Dwelling Units

Index # - File Name: 1.0022 - Single Family Dwellings Data\_Snohomish County.pdf

97 102470 RK	PRD-9,600	Residential 9,600 sq. ft.	SFR-Basic
97 102070 RK	R-5	Rural-5 Acre	Single Family Res-Combo
97 111272 RK	RRT-10	Rural Resource Transition-10	Single Family Res-Combo
97 100474 RK	PRD-9,600	Residential 9,600 sq. ft.	Single Family Res-Combo
97 110583 RK	R-5	Rural-5 Acre	Single Family Res-Combo
96 105573 RK	R-5	Rural-5 Acre	Single Family Res-Combo
97 106970 RK	R-5	Rural-5 Acre	Single Family Res-Combo
97 105553 MH	RD	Rural Diversification	Double Wide
94 140359 000 01 RK	R-9,600	Residential 9,600 sq. ft.	Single Family Res-Combo
97 110055 RK	R-8,400	Residential 8,400 sq. ft.	Duplex-Combo
96 109860 RK	R-7,200	Residential 7,200 sq. ft.	Single Family Res-Combo
97 108117 RK	R-5	Rural-5 Acre	Single Family Res-Combo
97 104390 MH	R-5	Rural-5 Acre	Double Wide
95 102144 000 01 MH	R-5	Rural-5 Acre	Double Wide
97 101583 MH	RRT-10	Rural Resource Transition-10	Triple Wide
97 104554 RK	R-5	Rural-5 Acre	Single Family Res-Combo
97 104964 RK	R-5	Rural-5 Acre	Duplex-Combo
97 110810 MH	R-5	Rural-5 Acre	Double Wide
96 110894 RK	R-5	Rural-5 Acre	Single Family Res-Combo
97 101996 RK	RC	Rural Conservation	Single Family Res-Combo
96 110933 RK	R-5	Rural-5 Acre	Single Family Res-Combo
97 104559 RK	R-5	Rural-5 Acre	SFR-Basic
97 103469 RK	R-5	Rural-5 Acre	Single Family Res-Combo
97 100655 RK	R-9,600	Residential 9,600 sq. ft.	Single Family Res-Combo
97 101114 RK	R-9,600	Residential 9,600 sq. ft.	Single Family Res-Combo
97 100119 RK	R-9,600	Residential 9,600 sq. ft.	Single Family Res-Combo
97 101207 RK	R-9,600	Residential 9,600 sq. ft.	Single Family Res-Combo
97 108247 RK	R-9,600	Residential 9,600 sq. ft.	SFR-Basic
97 108244 RK	R-9,600	Residential 9,600 sq. ft.	Single Family Res-Combo
97 108248 RK	R-9,600	Residential 9,600 sq. ft.	SFR-Basic
97 108249 RK	R-9,600	Residential 9,600 sq. ft.	SFR-Basic
97 110057 RK	R-9,600	Residential 9,600 sq. ft.	Single Family Res-Combo
97 110126 RK	R-9,600	Residential 9,600 sq. ft.	Single Family Res-Combo
97 108492 RK	R-9,600	Residential 9,600 sq. ft.	Single Family Res-Combo
97 110056 RK	R-9,600	Residential 9,600 sq. ft.	Single Family Res-Combo
97 110258 RK	R-9,600	Residential 9,600 sq. ft.	SFR-Basic
97 100400 RK	R-9,600	Residential 9,600 sq. ft.	Single Family Res-Combo
97 102321 RK	R-5	Rural-5 Acre	Single Family Res-Combo
97 104597 RK	R-5	Rural-5 Acre	Single Family Res-Combo
97 104596 RK	R-5	Rural-5 Acre	Single Family Res-Combo
97 106542 RK	R-5	Rural-5 Acre	Single Family Res-Combo
97 109111 RK	R-5	Rural-5 Acre	Single Family Res-Combo
97 109007 RK	R-5	Rural-5 Acre	Single Family Res-Combo
97 108856 RK	R-5	Rural-5 Acre	Single Family Res-Combo
97 100566 RK	R-5	Rural-5 Acre	Single Family Res-Combo
97 103346 RK	R-5	Rural-5 Acre	Single Family Res-Combo
97 108459 RK	R-5	Rural-5 Acre	Single Family Res-Combo

Accessory Dwelling Units

Index # - File Name: 1.0022 - Single Family Dwellings Data\_Snohomish County.pdf

97 105620 RK	R-5	Rural-5 Acre	Single Family Res-Combo
96 110595 RK	R-5	Rural-5 Acre	Single Family Res-Combo
97 109794 RK	R-5	Rural-5 Acre	Single Family Res-Combo
97 102219 RK	R-5	Rural-5 Acre	Single Family Res-Combo
96 110264 RK	R-8,400	Residential 8,400 sq. ft.	SFR-Basic
96 110758 RK	PRD-9,600	Residential 9,600 sq. ft.	SFR-Basic
97 100311 RK	PRD-9,600	Residential 9,600 sq. ft.	Single Family Res-Combo
96 110754 RK	PRD-9,600	Residential 9,600 sq. ft.	Single Family Res-Combo
97 100438 RK	CITY	City	SFR-Basic
97 100439 RK	CITY	City	SFR-Basic
97 109461 MH	R-5	Rural-5 Acre	Double Wide
97 102282 RK	PRD-9,600	Residential 9,600 sq. ft.	Single Family Res-Combo
96 110759 RK	PRD-9,600	Residential 9,600 sq. ft.	SFR-Basic
97 103286 RK	PRD-9,600	Residential 9,600 sq. ft.	Single Family Res-Combo
96 110753 RK	PRD-9,600	Residential 9,600 sq. ft.	SFR-Basic
97 103937 RK	R-5	Rural-5 Acre	Single Family Res-Combo
97 101408 RK	R-5	Rural-5 Acre	SFR-Basic
97 101219 MH	F	Forestry	Double Wide
97 100892 RK	F	Forestry	Single Family Res-Combo
97 103794 MH	A-10	Agriculture-10 Acre	Double Wide
97 101962 RK	CITY	City	SFR-Basic
97 101965 RK	CITY	City	Single Family Res-Combo
97 101507 RK	R-5	Rural-5 Acre	Single Family Res-Combo
96 103064 RK	R-5	Rural-5 Acre	Single Family Res-Combo
97 101872 RK	R-5	Rural-5 Acre	Single Family Res-Combo
97 107679 RK	R-5	Rural-5 Acre	Single Family Res-Combo
97 102732 RK	R-5	Rural-5 Acre	Single Family Res-Combo
97 101608 RK	CITY	City	Single Family Res-Combo
97 100058 RK	CITY	City	SFR-Basic
97 100060 RK	CITY	City	Single Family Res-Combo
97 100442 RK	CITY	City	SFR-Basic
97 100444 RK	CITY	City	SFR-Basic
97 100443 RK	CITY	City	SFR-Basic
97 100441 RK	CITY	City	SFR-Basic
97 103258 RK	R-5	Rural-5 Acre	Single Family Res-Combo
97 110566 RK	R-9,600	Residential 9,600 sq. ft.	Single Family Res-Combo
97 103808 MH	RRT-10	Rural Resource Transition-10	Double Wide
97 106109 RK	R-5	Rural-5 Acre	Single Family Res-Combo
97 100667 RK	CITY	City	SFR-Basic
97 103507 RK	R-5	Rural-5 Acre	Single Family Res-Combo
97 100668 RK	CITY	City	SFR-Basic
97 100547 RK	CITY	City	SFR-Basic
96 106218 RK	R-5	Rural-5 Acre	Single Family Res-Combo
97 105550 RK	R-5	Rural-5 Acre	Single Family Res-Combo
97 100082 RK	CITY	City	SFR-Basic
97 100084 RK	CITY	City	SFR-Basic
97 100086 RK	CITY	City	SFR-Basic

Accessory Dwelling Units

Index # - File Name: 1.0022 - Single Family Dwellings Data\_Snohomish County.pdf

97 100085 RK	CITY	City	SFR-Basic
97 100437 RK	CITY	City	SFR-Basic
97 101280 RK	PRD-9,600	Residential 9,600 sq. ft.	Single Family Res-Combo
97 103665 RK	PRD-9,600	Residential 9,600 sq. ft.	Single Family Res-Combo
96 110184 MH	R-5	Rural-5 Acre	Double Wide
97 101567 RK	PRD-9,600	Residential 9,600 sq. ft.	SFR-Basic
97 101568 RK	PRD-9,600	Residential 9,600 sq. ft.	Single Family Res-Combo
97 103524 RK	PRD-9,600	Residential 9,600 sq. ft.	Single Family Res-Combo
97 103756 RK	PRD-9,600	Residential 9,600 sq. ft.	Single Family Res-Combo
97 109290 RK	PRD-9,600	Residential 9,600 sq. ft.	Single Family Res-Combo
97 101564 RK	PRD-9,600	Residential 9,600 sq. ft.	SFR-Basic
96 110817 RK	PRD-9,600	Residential 9,600 sq. ft.	Single Family Res-Combo
97 110745 MH	R-5	Rural-5 Acre	Double Wide
97 106357 RK	R-9,600	Residential 9,600 sq. ft.	Single Family Res-Combo
97 100753 RK	R-5	Rural-5 Acre	Single Family Res-Combo
95 104272 000 01 RK	F	Forestry	Single Family Res-Combo
97 100871 RK	R-9,600	Residential 9,600 sq. ft.	Duplex-Combo
97 107199 RK	R-5	Rural-5 Acre	Single Family Res-Combo
97 105596 RK	R-5	Rural-5 Acre	Single Family Res-Combo
97 105687 RK	PRD-LDMR	Low Density Multiple Reside	SFR-Basic
97 105691 RK	PRD-LDMR	Low Density Multiple Reside	SFR-Basic
97 105692 RK	PRD-LDMR	Low Density Multiple Reside	SFR-Basic
97 105694 RK	PRD-LDMR	Low Density Multiple Reside	SFR-Basic
97 106780 RK	PRD-LDMR	Low Density Multiple Reside	SFR-Basic
97 106781 RK	PRD-LDMR	Low Density Multiple Reside	SFR-Basic
97 106782 RK	PRD-LDMR	Low Density Multiple Reside	SFR-Basic
97 106783 RK	PRD-LDMR	Low Density Multiple Reside	SFR-Basic
97 108274 RK	PRD-LDMR	Low Density Multiple Reside	SFR-Basic
97 108275 RK	PRD-LDMR	Low Density Multiple Reside	SFR-Basic
97 108276 RK	PRD-LDMR	Low Density Multiple Reside	SFR-Basic
97 108277 RK	PRD-LDMR	Low Density Multiple Reside	SFR-Basic
97 109378 RK	PRD-LDMR	Low Density Multiple Reside	SFR-Basic
97 109379 RK	PRD-LDMR	Low Density Multiple Reside	SFR-Basic
97 109380 RK	PRD-LDMR	Low Density Multiple Reside	SFR-Basic
97 109381 RK	PRD-LDMR	Low Density Multiple Reside	SFR-Basic
97 108279 RK	PRD-LDMR	Low Density Multiple Reside	SFR-Basic
97 108280 RK	PRD-LDMR	Low Density Multiple Reside	SFR-Basic
97 108281 RK	PRD-LDMR	Low Density Multiple Reside	SFR-Basic
97 108282 RK	PRD-LDMR	Low Density Multiple Reside	SFR-Basic
97 108601 RK	PRD-LDMR	Low Density Multiple Reside	SFR-Basic
97 108607 RK	PRD-LDMR	Low Density Multiple Reside	SFR-Basic
97 108611 RK	PRD-LDMR	Low Density Multiple Reside	SFR-Basic
97 108615 RK	PRD-LDMR	Low Density Multiple Reside	SFR-Basic
97 108619 RK	PRD-LDMR	Low Density Multiple Reside	SFR-Basic
97 108623 RK	PRD-LDMR	Low Density Multiple Reside	SFR-Basic
97 101855 RK	PRD-LDMR	Low Density Multiple Reside	SFR-Basic
97 101856 RK	PRD-LDMR	Low Density Multiple Reside	SFR-Basic

Accessory Dwelling Units

Index # - File Name: 1.0022 - Single Family Dwellings Data\_Snohomish County.pdf

97 101857 RK	PRD-LDMR	Low Density Multiple Reside SFR-Basic
97 101858 RK	PRD-LDMR	Low Density Multiple Reside SFR-Basic
97 101860 RK	PRD-LDMR	Low Density Multiple Reside SFR-Basic
97 101861 RK	PRD-LDMR	Low Density Multiple Reside SFR-Basic
97 103151 RK	PRD-LDMR	Low Density Multiple Reside SFR-Basic
97 103152 RK	PRD-LDMR	Low Density Multiple Reside SFR-Basic
97 103153 RK	PRD-LDMR	Low Density Multiple Reside SFR-Basic
97 103154 RK	PRD-LDMR	Low Density Multiple Reside SFR-Basic
97 109383 RK	PRD-LDMR	Low Density Multiple Reside SFR-Basic
97 109384 RK	PRD-LDMR	Low Density Multiple Reside SFR-Basic
97 109385 RK	PRD-LDMR	Low Density Multiple Reside SFR-Basic
97 109386 RK	PRD-LDMR	Low Density Multiple Reside SFR-Basic
97 109387 RK	PRD-LDMR	Low Density Multiple Reside SFR-Basic
97 109388 RK	PRD-LDMR	Low Density Multiple Reside SFR-Basic
97 111618 RK	PRD-LDMR	Low Density Multiple Reside SFR-Basic
97 111619 RK	PRD-LDMR	Low Density Multiple Reside SFR-Basic
97 111620 RK	PRD-LDMR	Low Density Multiple Reside SFR-Basic
97 111621 RK	PRD-LDMR	Low Density Multiple Reside SFR-Basic
97 109986 RK	PRD-LDMR	Low Density Multiple Reside SFR-Basic
97 109987 RK	PRD-LDMR	Low Density Multiple Reside SFR-Basic
97 109988 RK	PRD-LDMR	Low Density Multiple Reside SFR-Basic
97 109989 RK	PRD-LDMR	Low Density Multiple Reside SFR-Basic
97 109029 RK	PRD-LDMR	Low Density Multiple Reside SFR-Basic
97 109031 RK	PRD-LDMR	Low Density Multiple Reside SFR-Basic
97 109032 RK	PRD-LDMR	Low Density Multiple Reside SFR-Basic
97 109033 RK	PRD-LDMR	Low Density Multiple Reside SFR-Basic
97 106784 RK	PRD-LDMR	Low Density Multiple Reside SFR-Basic
97 106785 RK	PRD-LDMR	Low Density Multiple Reside SFR-Basic
97 106786 RK	PRD-LDMR	Low Density Multiple Reside SFR-Basic
97 106787 RK	PRD-LDMR	Low Density Multiple Reside SFR-Basic
97 100175 RK	PRD-LDMR	Low Density Multiple Reside SFR-Basic
97 100176 RK	PRD-LDMR	Low Density Multiple Reside SFR-Basic
97 100177 RK	PRD-LDMR	Low Density Multiple Reside SFR-Basic
97 100180 RK	PRD-LDMR	Low Density Multiple Reside SFR-Basic
97 100208 RK	PRD-LDMR	Low Density Multiple Reside SFR-Basic
97 100210 RK	PRD-LDMR	Low Density Multiple Reside SFR-Basic
97 100211 RK	PRD-LDMR	Low Density Multiple Reside SFR-Basic
97 100212 RK	PRD-LDMR	Low Density Multiple Reside SFR-Basic
97 103839 RK	PRD-LDMR	Low Density Multiple Reside SFR-Basic
97 103838 RK	PRD-LDMR	Low Density Multiple Reside SFR-Basic
97 103837 RK	PRD-LDMR	Low Density Multiple Reside SFR-Basic
97 103836 RK	PRD-LDMR	Low Density Multiple Reside SFR-Basic
97 103835 RK	PRD-LDMR	Low Density Multiple Reside SFR-Basic
97 103834 RK	PRD-LDMR	Low Density Multiple Reside SFR-Basic
97 109023 RK	PRD-LDMR	Low Density Multiple Reside SFR-Basic
97 109024 RK	PRD-LDMR	Low Density Multiple Reside SFR-Basic
97 109025 RK	PRD-LDMR	Low Density Multiple Reside SFR-Basic



Accessory Dwelling Units

Index # - File Name: 1.0022 - Single Family Dwellings Data\_Snohomish County.pdf

97 109026 RK	PRD-LDMR	Low Density Multiple Reside	SFR-Basic
97 109991 RK	PRD-LDMR	Low Density Multiple Reside	SFR-Basic
97 109992 RK	PRD-LDMR	Low Density Multiple Reside	SFR-Basic
97 109993 RK	PRD-LDMR	Low Density Multiple Reside	SFR-Basic
97 109994 RK	PRD-LDMR	Low Density Multiple Reside	SFR-Basic
97 111622 RK	PRD-LDMR	Low Density Multiple Reside	SFR-Basic
97 111623 RK	PRD-LDMR	Low Density Multiple Reside	SFR-Basic
97 111624 RK	PRD-LDMR	Low Density Multiple Reside	SFR-Basic
97 111625 RK	PRD-LDMR	Low Density Multiple Reside	SFR-Basic
97 104502 RK	PRD-LDMR	Low Density Multiple Reside	SFR-Basic
97 104503 RK	PRD-LDMR	Low Density Multiple Reside	SFR-Basic
97 104504 RK	PRD-LDMR	Low Density Multiple Reside	SFR-Basic
97 104505 RK	PRD-LDMR	Low Density Multiple Reside	SFR-Basic
97 103829 RK	PRD-LDMR	Low Density Multiple Reside	SFR-Basic
97 103831 RK	PRD-LDMR	Low Density Multiple Reside	SFR-Basic
97 103832 RK	PRD-LDMR	Low Density Multiple Reside	SFR-Basic
97 103833 RK	PRD-LDMR	Low Density Multiple Reside	SFR-Basic
97 100473 MH	NB	Neighborhood Business	MH Park-Single Wide
97 105186 MH	R-5	Rural-5 Acre	Double Wide
97 100168 RK	PRD-9,600	Residential 9,600 sq. ft.	SFR-Basic
97 100167 RK	PRD-9,600	Residential 9,600 sq. ft.	SFR-Basic
97 101296 RK	PRD-9,600	Residential 9,600 sq. ft.	SFR-Basic
97 101298 RK	PRD-9,600	Residential 9,600 sq. ft.	SFR-Basic
97 101294 RK	PRD-9,600	Residential 9,600 sq. ft.	SFR-Basic
97 101297 RK	PRD-9,600	Residential 9,600 sq. ft.	SFR-Basic
97 101299 RK	PRD-9,600	Residential 9,600 sq. ft.	SFR-Basic
96 105708 MH	R-5	Rural-5 Acre	Double Wide
97 103554 RK	R-5	Rural-5 Acre	Single Family Res-Combo
97 103696 RK	CITY	City	Single Family Res-Combo
97 101921 RK	R-5	Rural-5 Acre	Single Family Res-Combo
97 102893 RK	TRIBES	Native American Land	Single Family Res-Combo
97 104604 RK	R-5	Rural-5 Acre	Single Family Res-Combo
97 103040 RK	R-5	Rural-5 Acre	Single Family Res-Combo
97 110032 RK	R-5	Rural-5 Acre	SFR-Basic
95 106574 000 01 RK	R-5	Rural-5 Acre	Single Family Res-Combo
97 108207 RK	R-5	Rural-5 Acre	Single Family Res-Combo
97 108879 RK	R-5	Rural-5 Acre	Single Family Res-Combo
97 102916 MH	R-5	Rural-5 Acre	Double Wide
97 106709 MH	RD	Rural Diversification	Double Wide
97 105766 MH	R-5	Rural-5 Acre	Double Wide
97 101015 RK	R-5	Rural-5 Acre	Single Family Res-Combo
96 110433 RK	R-5	Rural-5 Acre	SFR-Basic
97 102655 RK	R-5	Rural-5 Acre	Single Family Res-Combo
96 110872 RK	R-7,200	Residential 7,200 sq. ft.	Single Family Res-Combo
97 105703 RK	R-5	Rural-5 Acre	Single Family Res-Combo
97 102141 RK	CITY	City	Single Family Res-Combo
97 105679 RK	PRD-9,600	Residential 9,600 sq. ft.	SFR-Basic

Accessory Dwelling Units

Index # - File Name: 1.0022 - Single Family Dwellings Data\_Snohomish County.pdf

97 105680 RK	PRD-9,600	Residential 9,600 sq. ft.	SFR-Basic
97 105678 RK	PRD-9,600	Residential 9,600 sq. ft.	SFR-Basic
97 105681 RK	PRD-9,600	Residential 9,600 sq. ft.	SFR-Basic
97 105677 RK	PRD-9,600	Residential 9,600 sq. ft.	SFR-Basic
97 105386 RK	PRD-9,600	Residential 9,600 sq. ft.	SFR-Basic
97 101165 RK	RC	Rural Conservation	Single Family Res-Combo
97 103297 RK	F	Forestry	Single Family Res-Combo
97 102634 RK	F	Forestry	Single Family Res-Combo
97 106932 RK	F	Forestry	Single Family Res-Combo
97 109995 RK	R-5	Rural-5 Acre	Single Family Res-Combo
97 106448 RK	R-5	Rural-5 Acre	Single Family Res-Combo
96 110317 RK	R-5	Rural-5 Acre	Single Family Res-Combo
97 100453 RK	PRD-9,600	Residential 9,600 sq. ft.	Single Family Res-Combo
97 101150 RK	R-5	Rural-5 Acre	SFR-Basic
97 100391 RK	R-5	Rural-5 Acre	Single Family Res-Combo
97 100392 RK	R-5	Rural-5 Acre	Single Family Res-Combo
97 104714 RK	R-5	Rural-5 Acre	Single Family Res-Combo
96 109962 RK	CITY	City	Single Family Res-Combo
96 109960 RK	CITY	City	Single Family Res-Combo
97 108765 RK	CITY	City	SFR-Basic
97 108766 RK	CITY	City	SFR-Basic
97 108767 RK	CITY	City	SFR-Basic
97 108768 RK	CITY	City	SFR-Basic
97 108769 RK	CITY	City	SFR-Basic
97 108771 RK	CITY	City	SFR-Basic
96 109455 RK	R-5	Rural-5 Acre	Single Family Res-Combo
97 100510 RK	R-5	Rural-5 Acre	Single Family Res-Combo
97 107571 RK	R-5	Rural-5 Acre	Single Family Res-Combo
97 110523 RK	RB	Rural Business	Duplex-Combo
97 100435 RK	R-5	Rural-5 Acre	SFR-Basic
97 111067 MH	R-5	Rural-5 Acre	Double Wide
97 104204 MH	RC	Rural Conservation	Double Wide
97 102564 MH	R-5	Rural-5 Acre	Double Wide
97 106959 RK	R-5	Rural-5 Acre	Single Family Res-Combo
97 110419 RK	R-5	Rural-5 Acre	Single Family Res-Combo
97 108323 MH	RD	Rural Diversification	Double Wide
97 100327 MH	R-5	Rural-5 Acre	Double Wide
96 109196 MH	RD	Rural Diversification	Double Wide
97 102913 RK	RD	Rural Diversification	Single Family Res-Combo
96 109914 MH	R-5	Rural-5 Acre	Single Wide
97 101479 RK	RD	Rural Diversification	Single Family Res-Combo
94 140782 000 01 RK	R-5	Rural-5 Acre	Single Family Res-Combo
96 103255 MH	RD	Rural Diversification	Double Wide
97 104974 MH	R-5	Rural-5 Acre	Double Wide
97 102188 RK	R-5	Rural-5 Acre	Single Family Res-Combo
97 107076 MH	R-5	Rural-5 Acre	Double Wide
96 110588 MH	A-10	Agriculture-10 Acre	Double Wide

Accessory Dwelling Units

Index # - File Name: 1.0022 - Single Family Dwellings Data\_Snohomish County.pdf

97 107394 MH	R-5	Rural-5 Acre	Single Wide
97 105579 RK	R-5	Rural-5 Acre	Single Family Res-Combo
97 109714 RK	R-5	Rural-5 Acre	Single Family Res-Combo
97 101034 RK	R-5	Rural-5 Acre	Single Family Res-Combo
97 108110 MH	R-5	Rural-5 Acre	Single Wide
97 106020 MH	R-5	Rural-5 Acre	Double Wide
97 102097 RK	R-5	Rural-5 Acre	Single Family Res-Combo
97 104647 RK	R-5	Rural-5 Acre	Single Family Res-Combo
97 108953 MH	R-5	Rural-5 Acre	Double Wide
97 105516 RK	R-5	Rural-5 Acre	Single Family Res-Combo
97 103901 RK	R-5	Rural-5 Acre	Single Family Res-Combo
96 110503 MH	R-5	Rural-5 Acre	Single Wide
97 102919 RK	R-5	Rural-5 Acre	Single Family Res-Combo
97 109526 MH	R-5	Rural-5 Acre	Double Wide
97 105103 MH	R-5	Rural-5 Acre	Single Wide
97 100636 MH	R-5	Rural-5 Acre	Double Wide
97 103384 RK	R-5	Rural-5 Acre	Accessory Apt Detached-Combo
96 108778 MH	R-5	Rural-5 Acre	Double Wide
97 107807 MH	R-5	Rural-5 Acre	Double Wide
97 102112 MH	R-5	Rural-5 Acre	Triple Wide
97 106141 RK	R-5	Rural-5 Acre	Single Family Res-Combo
97 107728 RK	R-5	Rural-5 Acre	SFR-Basic
97 107252 MH	R-5	Rural-5 Acre	Double Wide
95 106891 MH	R-5	Rural-5 Acre	Double Wide
96 109011 RK	R-5	Rural-5 Acre	Single Family Res-Combo
97 104095 MH	R-5	Rural-5 Acre	Double Wide
95 106113 RK	R-5	Rural-5 Acre	Single Family Res-Combo
97 109585 RK	R-5	Rural-5 Acre	Single Family Res-Combo
97 100730 RK	R-5	Rural-5 Acre	Single Family Res-Combo
97 108691 RK	R-5	Rural-5 Acre	Single Family Res-Combo
97 108710 RK	R-5	Rural-5 Acre	SFR-Basic
97 104646 RK	R-5	Rural-5 Acre	Single Family Res-Combo
97 104643 RK	R-5	Rural-5 Acre	Single Family Res-Combo
97 104463 RK	R-5	Rural-5 Acre	Single Family Res-Combo
97 106060 MH	A-10 : R-5	Agriculture-10 Acre : Rural-5	Single Wide
97 100841 RK	R-5	Rural-5 Acre	Single Family Res-Combo
97 108096 MH	R-5	Rural-5 Acre	Double Wide
95 101320 000 01 RK	R-5	Rural-5 Acre	Single Family Res-Combo
97 105264 RK	R-5	Rural-5 Acre	Single Family Res-Combo
97 106972 MH	R-5	Rural-5 Acre	Triple Wide
97 105071 MH	R-5	Rural-5 Acre	Double Wide
97 105064 RK	R-5	Rural-5 Acre	Single Family Res-Combo
97 109477 MH	R-5	Rural-5 Acre	Double Wide
96 110520 MH	R-5	Rural-5 Acre	Single Wide
97 104848 MH	CITY	City	Double Wide
97 110671 MH	R-5	Rural-5 Acre	Double Wide
96 110733 MH	R-5	Rural-5 Acre	Double Wide

Accessory Dwelling Units

Index # - File Name: 1.0022 - Single Family Dwellings Data\_Snohomish County.pdf

96 108427 RK	R-5	Rural-5 Acre	Single Family Res-Combo
97 107317 MH	R-5	Rural-5 Acre	Double Wide
97 100073 RK	R-5	Rural-5 Acre	Single Family Res-Combo
97 106031 RK	R-5	Rural-5 Acre	Single Family Res-Combo
97 105776 MH	R-5	Rural-5 Acre	Double Wide
97 105554 MH	R-5	Rural-5 Acre	Triple Wide
97 103751 MH	R-5	Rural-5 Acre	Single Wide
97 110344 MH	R-5	Rural-5 Acre	Double Wide
97 100028 MH	R-5	Rural-5 Acre	Double Wide
95 109601 000 01 MH	R-5	Rural-5 Acre	Double Wide
97 103509 RK	CITY	City	Single Family Res-Combo
97 105217 MH	R-5	Rural-5 Acre	Double Wide
97 103625 RK	CITY	City	Single Family Res-Combo
97 104486 RK	SA-1	Suburban Agriculture-1 Acre	Single Family Res-Combo
97 108136 RK	SA-1	Suburban Agriculture-1 Acre	Single Family Res-Combo
97 107563 RK	CITY	City	Single Family Res-Combo
97 102712 MH	RRT-10	Rural Resource Transition-10	Double Wide
96 109036 RK	R-5	Rural-5 Acre	Single Family Res-Combo
97 104120 MH	R-5	Rural-5 Acre	Double Wide
97 108481 RK	R-5	Rural-5 Acre	SFR-Basic
97 100116 MH	R-5	Rural-5 Acre	Double Wide
96 102354 MH	R-5	Rural-5 Acre	Double Wide
97 105368 MH	R-5	Rural-5 Acre	Double Wide
96 105699 MH	R-5	Rural-5 Acre	Double Wide
97 108431 RK	CITY	City	Accessory Apt Detached-Combo
97 102228 MH	R-5	Rural-5 Acre	Single Wide
96 106117 RK	R-5	Rural-5 Acre	Single Family Res-Combo
97 109906 RK	R-5	Rural-5 Acre	Single Family Res-Combo
96 110755 RK	R-5	Rural-5 Acre	Single Family Res-Combo
97 101224 RK	R-5	Rural-5 Acre	Single Family Res-Combo
97 104078 RK	R-5	Rural-5 Acre	SFR-Basic
97 103999 RK	R-5	Rural-5 Acre	SFR-Basic
97 104079 RK	R-5	Rural-5 Acre	SFR-Basic
97 110051 RK	R-5	Rural-5 Acre	Single Family Res-Combo
97 106463 RK	R-5	Rural-5 Acre	Single Family Res-Combo
97 101990 RK	R-5	Rural-5 Acre	Single Family Res-Combo
97 101986 RK	R-5	Rural-5 Acre	Single Family Res-Combo
97 109177 RK	R-5	Rural-5 Acre	Single Family Res-Combo
97 102289 RK	R-5	Rural-5 Acre	Single Family Res-Combo
96 110535 RK	R-5	Rural-5 Acre	Single Family Res-Combo
97 109265 RK	R-5	Rural-5 Acre	Single Family Res-Combo
97 109267 RK	R-5	Rural-5 Acre	Single Family Res-Combo
97 107702 RK	R-5	Rural-5 Acre	Single Family Res-Combo
96 110151 RK	R-5	Rural-5 Acre	Single Family Res-Combo
97 110029 RK	R-5	Rural-5 Acre	Single Family Res-Combo
97 104229 RK	R-5	Rural-5 Acre	Single Family Res-Combo
97 110558 RK	R-5	Rural-5 Acre	SFR-Basic

Accessory Dwelling Units

Index # - File Name: 1.0022 - Single Family Dwellings Data\_Snohomish County.pdf

97 107637 RK	R-5	Rural-5 Acre	Single Family Res-Combo
97 107633 RK	R-5	Rural-5 Acre	Single Family Res-Combo
97 109142 RK	R-5	Rural-5 Acre	Single Family Res-Combo
97 105200 RK	R-5	Rural-5 Acre	Single Family Res-Combo
96 110536 RK	R-5	Rural-5 Acre	Single Family Res-Combo
97 100321 RK	R-5	Rural-5 Acre	Single Family Res-Combo
97 106365 RK	R-5	Rural-5 Acre	SFR-Basic
97 101805 RK	R-5	Rural-5 Acre	Single Family Res-Combo
97 100790 RK	R-5	Rural-5 Acre	Single Family Res-Combo
97 100793 RK	R-5	Rural-5 Acre	SFR-Basic
97 104841 MH	R-5	Rural-5 Acre	Double Wide
96 110457 MH	R-5	Rural-5 Acre	Double Wide
96 110869 RK	RRT-10	Rural Resource Transition-1	(Single Family Res-Combo
97 100519 RK	RRT-10	Rural Resource Transition-1	(SFR-Basic
97 109538 RK	CITY	City	Single Family Res-Combo
96 110819 RK	RRT-10	Rural Resource Transition-1	(Single Family Res-Combo
97 105048 RK	RRT-10	Rural Resource Transition-1	(Single Family Res-Combo
97 104082 RK	R-5	Rural-5 Acre	SFR-Basic
97 104081 RK	R-5	Rural-5 Acre	SFR-Basic
97 103023 RK	R-5	Rural-5 Acre	SFR-Basic
97 103026 RK	R-5	Rural-5 Acre	SFR-Basic
97 103027 RK	R-5	Rural-5 Acre	SFR-Basic
97 104937 MH	R-5	Rural-5 Acre	Double Wide
97 108326 RK	CITY	City	SFR-Basic
97 107421 RK	RRT-10	Rural Resource Transition-1	(Single Family Res-Combo
97 108239 MH	SA-1	Suburban Agriculture-1 Acre	Double Wide
97 102511 RK	R-5	Rural-5 Acre	Single Family Res-Combo
97 105390 RK	R-5	Rural-5 Acre	Single Family Res-Combo
96 110799 RK	CITY	City	Duplex-Combo
97 105367 MH	CITY	City	Triple Wide
97 100784 RK	RRT-10	Rural Resource Transition-1	(Single Family Res-Combo
97 104431 RK	R-5	Rural-5 Acre	Single Family Res-Combo
96 109037 RK	PRD SA-1	Suburban Agriculture-1 Acre	Single Family Res-Combo
96 110786 RK	R-5	Rural-5 Acre	Single Family Res-Combo
97 107698 RK	R-9,600	Residential 9,600 sq. ft.	Duplex-Combo
97 102241 RK	CITY	City	Duplex-Combo
97 105421 MH	R-5	Rural-5 Acre	Triple Wide
97 106040 RK	R-7,200	Residential 7,200 sq. ft.	Single Family Res-Combo
96 106273 RK	R-5	Rural-5 Acre	Single Family Res-Combo
95 102911 000 01 MH	R-5	Rural-5 Acre	Single Wide
97 103008 RK	R-5	Rural-5 Acre	SFR-Basic
97 103012 RK	R-5	Rural-5 Acre	SFR-Basic
97 109328 RK	CITY	City	Single Family Res-Combo
97 102114 RK	CITY	City	Single Family Res-Combo
97 103755 MH	A-10	Agriculture-10 Acre	Single Wide
96 109603 RK	R-5	Rural-5 Acre	Single Family Res-Combo
97 101660 MH	R-5	Rural-5 Acre	Double Wide

Accessory Dwelling Units

Index # - File Name: 1.0022 - Single Family Dwellings Data\_Snohomish County.pdf

96 110710 RK	R-5	Rural-5 Acre	Single Family Res-Combo
97 102081 MH	RRT-10	Rural Resource Transition-10	Single Wide
97 106287 MH	R-5	Rural-5 Acre	Single Wide
97 101537 MH	RRT-10	Rural Resource Transition-10	Double Wide
97 107451 RK	R-5	Rural-5 Acre	Single Family Res-Combo
97 108742 RK	R-5	Rural-5 Acre	Single Family Res-Combo
97 103932 RK	R-5	Rural-5 Acre	Single Family Res-Combo
97 100723 RK	R-5	Rural-5 Acre	SFR-Basic
97 100018 RK	R-5	Rural-5 Acre	SFR-Basic
97 107034 RK	R-5	Rural-5 Acre	Single Family Res-Combo
97 107368 RK	R-5	Rural-5 Acre	Single Family Res-Combo
97 106864 RK	R-5	Rural-5 Acre	Single Family Res-Combo
97 105548 RK	R-5	Rural-5 Acre	SFR-Basic
97 103703 MH	R-5	Rural-5 Acre	Triple Wide
97 101285 MH	R-5	Rural-5 Acre	Double Wide
96 108456 RK	CITY	City	Single Family Res-Combo
97 106110 RK	CITY	City	Single Family Res-Combo
96 108326 RK	R-5	Rural-5 Acre	Single Family Res-Combo
97 107748 MH	R-7,200	Residential 7,200 sq. ft.	Triple Wide
97 101709 RK	R-5	Rural-5 Acre	Single Family Res-Combo
97 101389 MH	R-5	Rural-5 Acre	Double Wide
97 110431 RK	R-5	Rural-5 Acre	Single Family Res-Combo
97 105002 MH	R-5	Rural-5 Acre	Double Wide
97 108693 MH	R-5	Rural-5 Acre	Double Wide
97 104727 RK	R-5	Rural-5 Acre	Single Family Res-Combo
97 108341 RK	R-5	Rural-5 Acre	Single Family Res-Combo
97 106188 RK	R-5	Rural-5 Acre	Single Family Res-Combo
97 106540 RK	CITY	City	Single Family Res-Combo
96 105469 RK	R-5	Rural-5 Acre	Single Family Res-Combo
97 108515 RK	R-9,600	Residential 9,600 sq. ft.	Single Family Res-Combo
97 102184 RK	CITY	City	Single Family Res-Combo
96 110725 RK	R-9,600	Residential 9,600 sq. ft.	Single Family Res-Combo
97 108513 RK	R-9,600	Residential 9,600 sq. ft.	Single Family Res-Combo
97 106574 RK	R-9,600	Residential 9,600 sq. ft.	SFR-Basic
97 103944 RK	R-9,600	Residential 9,600 sq. ft.	Single Family Res-Combo
97 103830 RK	R-9,600	Residential 9,600 sq. ft.	Single Family Res-Combo
97 111395 RK	R-9,600	Residential 9,600 sq. ft.	Single Family Res-Combo
97 111502 MH	PRD-7,200(Mc	Residential 7,200 sq. ft.	Double Wide
97 108753 MH	PRD-7,200(Mc	Residential 7,200 sq. ft.	Single Wide
96 110952 RK	R-7,200	Residential 7,200 sq. ft.	Single Family Res-Combo
97 104774 RK	R-9,600	Residential 9,600 sq. ft.	Single Family Res-Combo
97 100110 RK	R-9,600	Residential 9,600 sq. ft.	SFR-Basic
97 100112 RK	R-9,600	Residential 9,600 sq. ft.	SFR-Basic
97 104967 RK	R-5	Rural-5 Acre	Single Family Res-Combo
97 105069 MH	R-9,600	Residential 9,600 sq. ft.	Double Wide
97 104308 MH	R-7,200	Residential 7,200 sq. ft.	Double Wide
97 102687 MH	R-7,200	Residential 7,200 sq. ft.	Double Wide

Accessory Dwelling Units

Index # - File Name: 1.0022 - Single Family Dwellings Data\_Snohomish County.pdf

96 102168 MH	R-7,200	Residential 7,200 sq. ft.	Double Wide
96 110245 RK	R-7,200	Residential 7,200 sq. ft.	Duplex-Combo
97 101331 RK	R-9,600	Residential 9,600 sq. ft.	Single Family Res-Combo
97 104460 RK	R-8,400	Residential 8,400 sq. ft.	Single Family Res-Combo
96 109830 RK	R-5	Rural-5 Acre	Single Family Res-Combo
97 110142 RK	R-9,600	Residential 9,600 sq. ft.	Single Family Res-Combo
97 103852 RK	R-5	Rural-5 Acre	Single Family Res-Combo
97 104534 MH	R-7,200	Residential 7,200 sq. ft.	Double Wide
96 103852 RK	R-5	Rural-5 Acre	Single Family Res-Combo
97 104198 RK	R-5	Rural-5 Acre	Single Family Res-Combo
97 104121 RK	R-5	Rural-5 Acre	Single Family Res-Combo
97 106006 RK	R-5	Rural-5 Acre	Single Family Res-Combo
97 104495 RK	R-5	Rural-5 Acre	Single Family Res-Combo
97 103940 RK	R-5	Rural-5 Acre	Single Family Res-Combo
97 109766 RK	R-5	Rural-5 Acre	SFR-Basic
97 110793 RK	R-5	Rural-5 Acre	Single Family Res-Combo
97 102590 RK	R-5	Rural-5 Acre	Single Family Res-Combo
97 107831 MH	PRD-12,500(M	Residential 12,500 sq. ft.	Double Wide
97 110298 RK	R-5	Rural-5 Acre	SFR-Basic
97 110781 MH	R-5	Rural-5 Acre	Double Wide
97 103984 RK	R-5	Rural-5 Acre	Single Family Res-Combo
97 100832 RK	R-5	Rural-5 Acre	Single Family Res-Combo
97 111410 RK	R-5	Rural-5 Acre	Single Family Res-Combo
96 105969 001 00 RK	R-5	Rural-5 Acre	Accessory Apt Detached-Combo
96 105969 RK	R-5	Rural-5 Acre	Single Family Res-Combo
97 108261 MH	R-5	Rural-5 Acre	Double Wide
97 108389 RK	R-5	Rural-5 Acre	Single Family Res-Combo
97 107244 RK	R-9,600	Residential 9,600 sq. ft.	Single Family Res-Combo
96 110331 MH	R-5	Rural-5 Acre	Double Wide
92 140018 000 01 RK	CITY	City	Duplex-Combo
97 105653 RK	R-5	Rural-5 Acre	Single Family Res-Combo
97 101548 RK	F	Forestry	Single Family Res-Combo
97 104922 RK	F	Forestry	Single Family Res-Combo
94 140171 000 01 RK	F	Forestry	Single Family Res-Combo
97 108202 MH	R-5	Rural-5 Acre	Triple Wide
97 100565 RK	R-5	Rural-5 Acre	Single Family Res-Combo
97 107041 MH	R-5	Rural-5 Acre	Double Wide
97 106175 RK	R-9,600	Residential 9,600 sq. ft.	Single Family Res-Combo
97 109376 MH	R-5	Rural-5 Acre	Single Wide
97 108915 RK	R-5	Rural-5 Acre	Single Family Res-Combo
96 101088 MH	R-9,600	Residential 9,600 sq. ft.	Double Wide
97 105462 RK	R-5	Rural-5 Acre	Single Family Res-Combo
97 105982 RK	R-5	Rural-5 Acre	Single Family Res-Combo
97 103789 RK	R-5	Rural-5 Acre	Single Family Res-Combo
96 110687 RK	R-5	Rural-5 Acre	Single Family Res-Combo
96 110871 MH	R-5	Rural-5 Acre	Double Wide
96 110569 MH	LDMR	Low Density Multiple Reside	Double Wide

Accessory Dwelling Units

Index # - File Name: 1.0022 - Single Family Dwellings Data\_Snohomish County.pdf

97 101302 MH	LDMR	Low Density Multiple Reside	Double Wide
97 108862 RK	R-5	Rural-5 Acre	Single Family Res-Combo
97 100172 RK	CITY	City	Single Family Res-Combo
97 105146 RK	R-5	Rural-5 Acre	Single Family Res-Combo
97 103968 RK	R-7,200	Residential 7,200 sq. ft.	SFR-Basic
97 103510 RK	R-12,500	Residential 12,500 sq. ft.	Single Family Res-Combo
97 103809 RK	R-12,500	Residential 12,500 sq. ft.	Single Family Res-Combo
97 103102 RK	R-12,500	Residential 12,500 sq. ft.	Single Family Res-Combo
97 103913 MH	R-12,500	Residential 12,500 sq. ft.	Single Wide
97 106896 RK	R-9,600	Residential 9,600 sq. ft.	Single Family Res-Combo
97 106383 RK	R-5	Rural-5 Acre	Single Family Res-Combo
97 106137 RK	R-8,400	Residential 8,400 sq. ft.	Single Family Res-Combo
97 100881 RK	R-9,600	Residential 9,600 sq. ft.	Duplex-Combo
96 107765 MH	F	Forestry	Single Wide
97 107407 MH	R-5	Rural-5 Acre	Single Wide
96 109420 RK	R-9,600	Residential 9,600 sq. ft.	Single Family Res-Combo
97 102042 RK	R-5	Rural-5 Acre	Single Family Res-Combo
97 103229 RK	R-8,400	Residential 8,400 sq. ft.	Single Family Res-Combo
97 102211 MH	R-5	Rural-5 Acre	Double Wide
97 107832 MH	PRD-20,000(M	Residential 20,000 sq. ft.	Double Wide
97 110228 RK	R-9,600	Residential 9,600 sq. ft.	SFR-Basic
97 107920 RK	R-9,600	Residential 9,600 sq. ft.	SFR-Basic
95 105216 000 01 RK	F	Forestry	Single Family Res-Combo
97 109075 RK	R-9,600	Residential 9,600 sq. ft.	Single Family Res-Combo
97 101912 RK	F	Forestry	Single Family Res-Combo
97 104873 RK	F	Forestry	Single Family Res-Combo
97 105229 RK	F	Forestry	Single Family Res-Combo
97 110874 MH	F	Forestry	Single Wide
97 102936 MH	R-5	Rural-5 Acre	Double Wide
96 109396 RK	R-5	Rural-5 Acre	Single Family Res-Combo
97 100079 RK	R-5	Rural-5 Acre	Single Family Res-Combo
97 103527 MH	PRD-20,000(M	Residential 20,000 sq. ft.	Double Wide
97 101335 RK	R-5	Rural-5 Acre	Single Family Res-Combo
97 106376 RK	R-5	Rural-5 Acre	Single Family Res-Combo
97 100732 RK	R-5	Rural-5 Acre	Single Family Res-Combo
97 110697 RK	R-5	Rural-5 Acre	Single Family Res-Combo
96 107044 001 00 MH	R-5	Rural-5 Acre	Double Wide
96 107044 MH	R-5	Rural-5 Acre	Double Wide
97 101606 MH	R-5	Rural-5 Acre	Double Wide
95 100656 RK	R-9,600	Residential 9,600 sq. ft.	Single Family Res-Combo
97 110010 RK	R-8,400	Residential 8,400 sq. ft.	Single Family Res-Combo
97 108954 RK	R-5	Rural-5 Acre	Single Family Res-Combo
97 103939 RK	R-5	Rural-5 Acre	Single Family Res-Combo
96 110441 RK	R-5	Rural-5 Acre	Single Family Res-Combo
97 110151 MH	R-5	Rural-5 Acre	Triple Wide
96 106367 RK	R-5	Rural-5 Acre	Single Family Res-Combo
97 102503 RK	R-5	Rural-5 Acre	Single Family Res-Combo



Accessory Dwelling Units

Index # - File Name: 1.0022 - Single Family Dwellings Data\_Snohomish County.pdf

97 100891 RK	PRD-20,000	Residential 20,000 sq. ft.	Single Family Res-Combo
94 140690 000 01 RK	PRD-20,000	Residential 20,000 sq. ft.	Single Family Res-Combo
97 108468 RK	R-5	Rural-5 Acre	Single Family Res-Combo
97 109271 RK	R-5	Rural-5 Acre	Single Family Res-Combo
97 109012 MH	R-5	Rural-5 Acre	Single Wide
97 103853 RK	R-5	Rural-5 Acre	Single Family Res-Combo
97 108937 RK	R-5	Rural-5 Acre	Single Family Res-Combo
97 110064 RK	R-8,400	Residential 8,400 sq. ft.	Single Family Res-Combo
97 103882 RK	R-5	Rural-5 Acre	Single Family Res-Combo
97 110470 RK	F	Forestry	Single Family Res-Combo
97 105230 RK	R-9,600	Residential 9,600 sq. ft.	SFR-Basic
97 107289 RK	R-7,200	Residential 7,200 sq. ft.	Single Family Res-Combo
96 107680 RK	R-9,600	Residential 9,600 sq. ft.	Single Family Res-Combo
97 106063 MH	R-5	Rural-5 Acre	Double Wide
97 104864 MH	A-10	Agriculture-10 Acre	Double Wide
97 106316 RK	R-5	Rural-5 Acre	Single Family Res-Combo
96 110941 RK	A-10	Agriculture-10 Acre	Single Family Res-Combo
97 100135 MH	R-5	Rural-5 Acre	Single Wide
96 109643 MH	F and R : R-5	Forestry and Recreation : Ru	Double Wide
97 106458 RK	F	Forestry	Single Family Res-Combo
97 106115 MH	F	Forestry	Single Wide
97 109981 RK	R-5	Rural-5 Acre	Duplex-Combo
96 109389 RK	F	Forestry	Single Family Res-Combo
96 108175 RK	R-5	Rural-5 Acre	Accessory Apt Detached-Combo
97 105482 RK	R-5	Rural-5 Acre	Single Family Res-Combo
95 108090 MH	R-5	Rural-5 Acre	Double Wide
95 106416 000 01 RK	R-5	Rural-5 Acre	Single Family Res-Combo
97 102836 RK	A-10	Agriculture-10 Acre	Single Family Res-Combo
97 103363 RK	R-5	Rural-5 Acre	Single Family Res-Combo
96 110937 RK	PRD SA-1	Suburban Agriculture-1 Acre	Single Family Res-Combo
96 110694 MH	R-5	Rural-5 Acre	Double Wide
97 105666 MH	R-5	Rural-5 Acre	Double Wide
97 110443 RK	F	Forestry	Single Family Res-Combo
97 106815 MH	F	Forestry	Single Wide
97 108905 MH	R-5	Rural-5 Acre	Single Wide
97 106002 RK	R-5	Rural-5 Acre	Single Family Res-Combo
97 105485 RK	R-8,400	Residential 8,400 sq. ft.	SFR-Basic
97 105129 RK	R-5	Rural-5 Acre	Single Family Res-Combo
97 105187 RK	R-5	Rural-5 Acre	Single Family Res-Combo
97 105366 MH	R-5	Rural-5 Acre	Single Wide
97 107488 RK	R-12,500	Residential 12,500 sq. ft.	Single Family Res-Combo
97 105503 RK	R-5	Rural-5 Acre	Single Family Res-Combo
97 105566 RK	R-5	Rural-5 Acre	Single Family Res-Combo
97 105551 RK	R-5	Rural-5 Acre	Single Family Res-Combo
97 105552 RK	R-5	Rural-5 Acre	Single Family Res-Combo
97 105936 RK	A-10	Agriculture-10 Acre	Single Family Res-Combo
97 105193 RK	R-7,200	Residential 7,200 sq. ft.	Single Family Res-Combo

Accessory Dwelling Units

Index # - File Name: 1.0022 - Single Family Dwellings Data\_Snohomish County.pdf

97 105190 RK	R-7,200	Residential 7,200 sq. ft.	Single Family Res-Combo
97 105816 RK	R-7,200	Residential 7,200 sq. ft.	SFR-Basic
97 105192 RK	R-7,200	Residential 7,200 sq. ft.	Single Family Res-Combo
97 105641 RK	R-5	Rural-5 Acre	Single Family Res-Combo
97 105640 RK	R-5	Rural-5 Acre	Single Family Res-Combo
97 105570 RK	CITY	City	Duplex-Basic
97 106510 RK	R-5	Rural-5 Acre	Single Family Res-Combo
97 105712 MH	RRT-10	Rural Resource Transition-10	Single Wide
97 109391 RK	F	Forestry	Single Family Res-Combo
97 105757 RK	R-7,200	Residential 7,200 sq. ft.	Single Family Res-Combo
97 110487 RK	R-5	Rural-5 Acre	SFR-Basic
97 110290 RK	R-5	Rural-5 Acre	SFR-Basic
97 108161 RK	R-5	Rural-5 Acre	Single Family Res-Combo
97 105772 RK	R-8,400	Residential 8,400 sq. ft.	SFR-Basic
97 108661 MH	R-5	Rural-5 Acre	Triple Wide
97 110715 RK	R-5	Rural-5 Acre	Single Family Res-Combo
97 110883 RK	R-5	Rural-5 Acre	Single Family Res-Combo
97 105672 RK	R-5	Rural-5 Acre	Single Family Res-Combo
97 105852 MH	CITY	City	MH Park-Double Wide
97 105851 MH	CITY	City	MH Park-Double Wide
97 105165 RK	PRD-9,600	Residential 9,600 sq. ft.	Single Family Res-Combo
97 105960 MH	R-5	Rural-5 Acre	Single Wide
97 106539 RK	CITY	City	SFR-Basic
97 106538 RK	CITY	City	SFR-Basic
97 106537 RK	CITY	City	SFR-Basic
97 109894 RK	R-9,600	Residential 9,600 sq. ft.	Duplex-Basic
97 109671 RK	PRD-9,600	Residential 9,600 sq. ft.	Single Family Res-Combo
97 109672 RK	PRD-9,600	Residential 9,600 sq. ft.	Single Family Res-Combo
97 106394 RK	PRD-9,600	Residential 9,600 sq. ft.	Single Family Res-Combo
97 110703 RK	PRD-9,600	Residential 9,600 sq. ft.	SFR-Basic
97 110705 RK	PRD-9,600	Residential 9,600 sq. ft.	SFR-Basic
97 107051 RK	PRD-9,600	Residential 9,600 sq. ft.	SFR-Basic
97 106387 RK	PRD-9,600	Residential 9,600 sq. ft.	SFR-Basic
97 110825 RK	PRD-9,600	Residential 9,600 sq. ft.	SFR-Basic
97 107754 RK	PRD-9,600	Residential 9,600 sq. ft.	SFR-Basic
97 106466 RK	PRD-9,600	Residential 9,600 sq. ft.	Single Family Res-Combo
97 108463 RK	PRD-9,600	Residential 9,600 sq. ft.	SFR-Basic
97 107053 RK	PRD-9,600	Residential 9,600 sq. ft.	SFR-Basic
97 108791 RK	PRD-9,600	Residential 9,600 sq. ft.	SFR-Basic
97 107565 RK	PRD-9,600	Residential 9,600 sq. ft.	Single Family Res-Combo
97 107568 RK	PRD-9,600	Residential 9,600 sq. ft.	Single Family Res-Combo
97 106400 RK	PRD-9,600	Residential 9,600 sq. ft.	Single Family Res-Combo
97 107071 RK	PRD-9,600	Residential 9,600 sq. ft.	Single Family Res-Combo
97 107063 RK	PRD-9,600	Residential 9,600 sq. ft.	Single Family Res-Combo
97 106642 RK	PRD-9,600	Residential 9,600 sq. ft.	SFR-Basic
97 106404 RK	PRD-9,600	Residential 9,600 sq. ft.	SFR-Basic
97 106401 RK	PRD-9,600	Residential 9,600 sq. ft.	Single Family Res-Combo

Accessory Dwelling Units

Index # - File Name: 1.0022 - Single Family Dwellings Data\_Snohomish County.pdf

97 107352 RK	PRD-9,600	Residential 9,600 sq. ft.	SFR-Basic
97 107623 RK	PRD-9,600	Residential 9,600 sq. ft.	Single Family Res-Combo
97 107350 RK	PRD-9,600	Residential 9,600 sq. ft.	SFR-Basic
97 107054 RK	PRD-9,600	Residential 9,600 sq. ft.	Single Family Res-Combo
97 106403 RK	PRD-9,600	Residential 9,600 sq. ft.	SFR-Basic
97 106644 RK	PRD-9,600	Residential 9,600 sq. ft.	SFR-Basic
97 108792 RK	PRD-9,600	Residential 9,600 sq. ft.	SFR-Basic
97 108788 RK	PRD-9,600	Residential 9,600 sq. ft.	SFR-Basic
97 107085 RK	R-5	Rural-5 Acre	Single Family Res-Combo
97 107347 RK	R-5	Rural-5 Acre	Single Family Res-Combo
97 111359 RK	PRD-9,600	Residential 9,600 sq. ft.	Single Family Res-Combo
97 110870 RK	PRD-9,600	Residential 9,600 sq. ft.	Single Family Res-Combo
97 106075 MH	R-12,500	Residential 12,500 sq. ft.	Triple Wide
97 108789 RK	PRD-9,600	Residential 9,600 sq. ft.	SFR-Basic
97 110571 RK	PRD-9,600	Residential 9,600 sq. ft.	Single Family Res-Combo
97 106386 RK	PRD-9,600	Residential 9,600 sq. ft.	SFR-Basic
97 106388 RK	PRD-9,600	Residential 9,600 sq. ft.	Single Family Res-Combo
97 108317 RK	PRD-9,600	Residential 9,600 sq. ft.	SFR-Basic
97 109470 RK	PRD-9,600	Residential 9,600 sq. ft.	Single Family Res-Combo
97 109471 RK	PRD-9,600	Residential 9,600 sq. ft.	Single Family Res-Combo
97 108794 RK	PRD-9,600	Residential 9,600 sq. ft.	SFR-Basic
97 108331 RK	PRD-9,600	Residential 9,600 sq. ft.	Single Family Res-Combo
97 106144 RK	R-5	Rural-5 Acre	Single Family Res-Combo
97 106190 RK	R-5	Rural-5 Acre	Duplex-Combo
97 102713 RK	R-5	Rural-5 Acre	Single Family Res-Combo
97 107761 RK	R-5	Rural-5 Acre	Single Family Res-Combo
97 105972 RK	R-5	Rural-5 Acre	Single Family Res-Combo
97 105974 RK	R-5	Rural-5 Acre	Single Family Res-Combo
97 110561 RK	R-5	Rural-5 Acre	Single Family Res-Combo
97 108805 RK	R-5	Rural-5 Acre	Single Family Res-Combo
97 110438 RK	R-5	Rural-5 Acre	Single Family Res-Combo
97 109280 RK	R-5	Rural-5 Acre	Single Family Res-Combo
97 106582 RK	R-5	Rural-5 Acre	Single Family Res-Combo
97 108137 RK	R-5	Rural-5 Acre	Single Family Res-Combo
97 106460 RK	R-5	Rural-5 Acre	Single Family Res-Combo
97 106398 MH	CITY	City	MH Park-Double Wide
97 106515 RK	R-5	Rural-5 Acre	Single Family Res-Combo
97 108189 RK	R-5	Rural-5 Acre	Single Family Res-Combo
97 109720 MH	CITY	City	MH Park-Double Wide
97 106664 RK	LDMR	Low Density Multiple Reside	Duplex-Basic
97 109071 RK	R-5	Rural-5 Acre	Single Family Res-Combo
97 106643 RK	R-5	Rural-5 Acre	Single Family Res-Combo
97 106662 MH	R-7,200	Residential 7,200 sq. ft.	Double Wide
97 109036 RK	PRD-9,600	Residential 9,600 sq. ft.	SFR-Basic
97 109046 RK	PRD-9,600	Residential 9,600 sq. ft.	SFR-Basic
97 110107 RK	PRD-9,600	Residential 9,600 sq. ft.	SFR-Basic
97 109044 RK	PRD-9,600	Residential 9,600 sq. ft.	SFR-Basic

Accessory Dwelling Units

Index # - File Name: 1.0022 - Single Family Dwellings Data\_Snohomish County.pdf

97 107642 RK	PRD-9,600	Residential 9,600 sq. ft.	SFR-Basic
97 107643 RK	PRD-9,600	Residential 9,600 sq. ft.	SFR-Basic
97 107644 RK	PRD-9,600	Residential 9,600 sq. ft.	SFR-Basic
97 107645 RK	PRD-9,600	Residential 9,600 sq. ft.	SFR-Basic
97 107646 RK	PRD-9,600	Residential 9,600 sq. ft.	SFR-Basic
97 107648 RK	PRD-9,600	Residential 9,600 sq. ft.	SFR-Basic
97 107649 RK	PRD-9,600	Residential 9,600 sq. ft.	SFR-Basic
97 107650 RK	PRD-9,600	Residential 9,600 sq. ft.	SFR-Basic
97 109034 RK	PRD-9,600	Residential 9,600 sq. ft.	SFR-Basic
97 109043 RK	PRD-9,600	Residential 9,600 sq. ft.	SFR-Basic
97 109037 RK	PRD-9,600	Residential 9,600 sq. ft.	SFR-Basic
97 109041 RK	PRD-9,600	Residential 9,600 sq. ft.	SFR-Basic
97 107028 RK	PRD-9,600	Residential 9,600 sq. ft.	SFR-Basic
97 107029 RK	PRD-9,600	Residential 9,600 sq. ft.	SFR-Basic
97 107651 RK	PRD-9,600	Residential 9,600 sq. ft.	SFR-Basic
97 107652 RK	PRD-9,600	Residential 9,600 sq. ft.	SFR-Basic
97 107653 RK	PRD-9,600	Residential 9,600 sq. ft.	SFR-Basic
97 107654 RK	PRD-9,600	Residential 9,600 sq. ft.	SFR-Basic
97 101527 RK	R-20,000	Residential 20,000 sq. ft.	Single Family Res-Combo
97 110753 RK	R-20,000	Residential 20,000 sq. ft.	SFR-Basic
97 107586 RK	R-20,000	Residential 20,000 sq. ft.	SFR-Basic
97 110751 RK	R-20,000	Residential 20,000 sq. ft.	SFR-Basic
97 105405 RK	R-20,000	Residential 20,000 sq. ft.	Single Family Res-Combo
97 107584 RK	R-20,000	Residential 20,000 sq. ft.	Single Family Res-Combo
97 107576 RK	R-20,000	Residential 20,000 sq. ft.	SFR-Basic
97 104823 RK	R-20,000	Residential 20,000 sq. ft.	Single Family Res-Combo
97 107385 RK	R-20,000	Residential 20,000 sq. ft.	SFR-Basic
97 107386 RK	R-20,000	Residential 20,000 sq. ft.	SFR-Basic
97 107397 RK	R-20,000	Residential 20,000 sq. ft.	Single Family Res-Combo
97 107393 RK	R-20,000	Residential 20,000 sq. ft.	SFR-Basic
97 107387 RK	R-20,000	Residential 20,000 sq. ft.	SFR-Basic
97 107396 RK	R-20,000	Residential 20,000 sq. ft.	SFR-Basic
97 107388 RK	R-20,000	Residential 20,000 sq. ft.	SFR-Basic
97 105535 RK	R-20,000	Residential 20,000 sq. ft.	SFR-Basic
97 105529 RK	R-20,000	Residential 20,000 sq. ft.	SFR-Basic
97 105542 RK	R-20,000	Residential 20,000 sq. ft.	SFR-Basic
97 105544 RK	R-20,000	Residential 20,000 sq. ft.	SFR-Basic
97 105530 RK	R-20,000	Residential 20,000 sq. ft.	SFR-Basic
97 103635 RK	R-20,000	Residential 20,000 sq. ft.	SFR-Basic
97 103371 RK	R-20,000	Residential 20,000 sq. ft.	SFR-Basic
97 103369 RK	R-20,000	Residential 20,000 sq. ft.	SFR-Basic
97 103636 RK	R-20,000	Residential 20,000 sq. ft.	Single Family Res-Combo
97 103370 RK	R-20,000	Residential 20,000 sq. ft.	SFR-Basic
97 103639 RK	R-20,000	Residential 20,000 sq. ft.	Single Family Res-Combo
97 103367 RK	R-20,000	Residential 20,000 sq. ft.	SFR-Basic
97 103365 RK	R-20,000	Residential 20,000 sq. ft.	SFR-Basic
97 103633 RK	R-20,000	Residential 20,000 sq. ft.	SFR-Basic

Accessory Dwelling Units

Index # - File Name: 1.0022 - Single Family Dwellings Data\_Snohomish County.pdf

97 103634 RK	R-20,000	Residential 20,000 sq. ft.	SFR-Basic
97 107389 RK	R-20,000	Residential 20,000 sq. ft.	SFR-Basic
97 105538 RK	R-20,000	Residential 20,000 sq. ft.	SFR-Basic
97 105541 RK	R-20,000	Residential 20,000 sq. ft.	SFR-Basic
97 105526 RK	R-20,000	Residential 20,000 sq. ft.	SFR-Basic
97 105527 RK	R-20,000	Residential 20,000 sq. ft.	SFR-Basic
97 105536 RK	R-20,000	Residential 20,000 sq. ft.	SFR-Basic
97 107390 RK	R-20,000	Residential 20,000 sq. ft.	SFR-Basic
97 107391 RK	R-20,000	Residential 20,000 sq. ft.	SFR-Basic
97 109753 RK	R-20,000	Residential 20,000 sq. ft.	SFR-Basic
97 109752 RK	R-20,000	Residential 20,000 sq. ft.	SFR-Basic
97 109747 RK	R-20,000	Residential 20,000 sq. ft.	SFR-Basic
97 109756 RK	R-20,000	Residential 20,000 sq. ft.	SFR-Basic
97 109750 RK	R-20,000	Residential 20,000 sq. ft.	SFR-Basic
97 107577 RK	R-20,000	Residential 20,000 sq. ft.	SFR-Basic
97 105402 RK	R-20,000	Residential 20,000 sq. ft.	SFR-Basic
97 107579 RK	R-20,000	Residential 20,000 sq. ft.	Single Family Res-Combo
97 110752 RK	R-20,000	Residential 20,000 sq. ft.	SFR-Basic
97 105404 RK	R-20,000	Residential 20,000 sq. ft.	SFR-Basic
97 105401 RK	R-20,000	Residential 20,000 sq. ft.	SFR-Basic
97 109801 RK	R-20,000	Residential 20,000 sq. ft.	Single Family Res-Combo
97 102307 RK	R-5	Rural-5 Acre	Single Family Res-Combo
97 110408 RK	R-5	Rural-5 Acre	Single Family Res-Combo
97 103714 RK	R-5	Rural-5 Acre	Single Family Res-Combo
97 103716 RK	R-5	Rural-5 Acre	Single Family Res-Combo
97 100154 RK	CITY	City	Duplex-Combo
97 100159 RK	CITY	City	Duplex-Combo
97 100157 RK	CITY	City	Duplex-Combo
97 103298 RK	CITY	City	Duplex-Basic
97 103796 MH	R-12,500	Residential 12,500 sq. ft.	Double Wide
97 104936 RK	CITY	City	SFR-Basic
97 100160 RK	CITY	City	Single Family Res-Combo
97 106077 RK	CITY	City	SFR-Basic
97 106078 RK	CITY	City	SFR-Basic
97 106771 RK	CITY	City	SFR-Basic
97 106776 RK	CITY	City	SFR-Basic
97 106766 RK	CITY	City	SFR-Basic
97 109205 RK	R-20,000	Residential 20,000 sq. ft.	Single Family Res-Combo
97 103621 MH	NB	Neighborhood Business	Double Wide
97 107250 RK	CITY	City	SFR-Basic
97 107249 RK	CITY	City	SFR-Basic
97 107835 RK	CITY	City	SFR-Basic
97 107837 RK	CITY	City	SFR-Basic
97 107839 RK	CITY	City	SFR-Basic
97 107251 RK	CITY	City	SFR-Basic
97 107841 RK	CITY	City	SFR-Basic
97 107842 RK	CITY	City	SFR-Basic

Accessory Dwelling Units

Index # - File Name: 1.0022 - Single Family Dwellings Data\_Snohomish County.pdf

97 107843 RK	CITY	City	SFR-Basic
97 107845 RK	CITY	City	SFR-Basic
97 107847 RK	CITY	City	SFR-Basic
97 106769 RK	CITY	City	SFR-Basic
97 106767 RK	CITY	City	SFR-Basic
97 101305 RK	R-5	Rural-5 Acre	Single Family Res-Combo
97 106003 RK	R-5	Rural-5 Acre	Single Family Res-Combo
96 109271 RK	PRD SA-1	Suburban Agriculture-1 Acre	Single Family Res-Combo
97 106667 RK	PRD SA-1	Suburban Agriculture-1 Acre	Single Family Res-Combo
97 107806 RK	PRD SA-1	Suburban Agriculture-1 Acre	Single Family Res-Combo
97 104395 RK	PRD SA-1	Suburban Agriculture-1 Acre	Single Family Res-Combo
97 102210 RK	PRD SA-1	Suburban Agriculture-1 Acre	Single Family Res-Combo
97 106185 RK	PRD SA-1	Suburban Agriculture-1 Acre	Single Family Res-Combo
97 108258 RK	PRD SA-1	Suburban Agriculture-1 Acre	Single Family Res-Combo
97 104493 RK	PRD SA-1	Suburban Agriculture-1 Acre	Single Family Res-Combo
97 101954 RK	PRD SA-1	Suburban Agriculture-1 Acre	Single Family Res-Combo
97 103638 RK	PRD SA-1	Suburban Agriculture-1 Acre	Single Family Res-Combo
97 105134 RK	PRD SA-1	Suburban Agriculture-1 Acre	Single Family Res-Combo
97 106430 RK	PRD SA-1	Suburban Agriculture-1 Acre	Single Family Res-Combo
97 106229 RK	PRD SA-1	Suburban Agriculture-1 Acre	Single Family Res-Combo
97 104201 MH	R-12,500	Residential 12,500 sq. ft.	Double Wide
97 106223 RK	RD	Rural Diversification	Single Family Res-Combo
97 105805 MH	F	Forestry	Double Wide
97 104151 RK	R-5	Rural-5 Acre	Single Family Res-Combo
97 110546 RK	R-5	Rural-5 Acre	Single Family Res-Combo
97 105121 MH	R-5	Rural-5 Acre	Double Wide
97 104149 RK	R-5	Rural-5 Acre	Single Family Res-Combo
97 105842 RK	R-5	Rural-5 Acre	Single Family Res-Combo
97 104376 RK	CITY	City	SFR-Basic
97 104600 RK	CITY	City	SFR-Basic
97 106899 RK	CITY	City	SFR-Basic
97 104598 RK	CITY	City	SFR-Basic
97 109342 RK	CITY	City	SFR-Basic
97 104193 RK	CITY	City	SFR-Basic
97 105372 RK	CITY	City	SFR-Basic
97 105177 RK	CITY	City	SFR-Basic
97 105176 RK	CITY	City	SFR-Basic
97 104620 RK	CITY	City	SFR-Basic
97 104623 RK	CITY	City	SFR-Basic
97 105374 RK	CITY	City	Single Family Res-Combo
97 107557 RK	CITY	City	SFR-Basic
97 104377 RK	CITY	City	SFR-Basic
97 102330 RK	CITY	City	Single Family Res-Combo
97 105262 RK	CITY	City	SFR-Basic
97 105263 RK	CITY	City	SFR-Basic
97 108857 RK	CITY	City	SFR-Basic
97 102829 RK	PRD SA-1	Suburban Agriculture-1 Acre	Single Family Res-Combo

Accessory Dwelling Units

Index # - File Name: 1.0022 - Single Family Dwellings Data\_Snohomish County.pdf

97 109983 RK	R-5	Rural-5 Acre	Single Family Res-Combo
97 105761 MH	R-5	Rural-5 Acre	Double Wide
97 105424 RK	CITY	City	SFR-Basic
97 107708 RK	CITY	City	SFR-Basic
97 106497 RK	CITY	City	Single Family Res-Combo
97 107619 RK	CITY	City	SFR-Basic
97 105338 RK	CITY	City	Single Family Res-Combo
97 104954 RK	CITY	City	Single Family Res-Combo
97 107938 RK	CITY	City	SFR-Basic
97 106898 RK	CITY	City	Single Family Res-Combo
97 105140 RK	CITY	City	SFR-Basic
97 111113 RK	R-5	Rural-5 Acre	Single Family Res-Combo
97 109361 RK	R-5	Rural-5 Acre	Single Family Res-Combo
97 107260 RK	CITY	City	SFR-Basic
97 110550 RK	CITY	City	Single Family Res-Combo
97 109556 RK	CITY	City	SFR-Basic
97 107124 RK	CITY	City	SFR-Basic
97 107261 RK	CITY	City	SFR-Basic
97 108297 RK	CITY	City	Single Family Res-Combo
97 109555 RK	CITY	City	Single Family Res-Combo
97 109345 RK	CITY	City	SFR-Basic
97 107125 RK	CITY	City	SFR-Basic
97 105894 RK	CITY	City	SFR-Basic
97 105895 RK	CITY	City	SFR-Basic
97 111115 RK	CITY	City	SFR-Basic
97 104191 RK	CITY	City	SFR-Basic
97 108295 RK	CITY	City	Single Family Res-Combo
97 109019 RK	CITY	City	SFR-Basic
97 111114 RK	CITY	City	SFR-Basic
97 111118 RK	CITY	City	SFR-Basic
97 109018 RK	CITY	City	SFR-Basic
97 105615 RK	R-5	Rural-5 Acre	Single Family Res-Combo
97 104208 RK	MR	Multiple Residential	Duplex-Combo
97 104309 MH	R-5	Rural-5 Acre	Double Wide
97 104332 RK	CITY	City	Duplex-Combo
97 105031 RK	R-5	Rural-5 Acre	Single Family Res-Combo
97 105636 RK	R-5	Rural-5 Acre	Single Family Res-Combo
97 104441 RK	R-5	Rural-5 Acre	Single Family Res-Combo
97 104464 RK	R-8,400	Residential 8,400 sq. ft.	Single Family Res-Combo
97 108253 RK	CITY	City	SFR-Basic
97 108252 RK	CITY	City	SFR-Basic
97 107777 RK	CITY	City	SFR-Basic
97 107776 RK	CITY	City	SFR-Basic
97 107775 RK	CITY	City	SFR-Basic
97 105465 RK	CITY	City	SFR-Basic
97 105467 RK	CITY	City	SFR-Basic
97 102799 RK	CITY	City	Single Family Res-Combo

Accessory Dwelling Units

Index # - File Name: 1.0022 - Single Family Dwellings Data\_Snohomish County.pdf

97 105472 RK	CITY	City	SFR-Basic
97 106935 RK	CITY	City	SFR-Basic
97 106933 RK	CITY	City	SFR-Basic
97 105994 RK	CITY	City	SFR-Basic
97 106930 RK	CITY	City	SFR-Basic
97 105473 RK	CITY	City	SFR-Basic
97 105471 RK	CITY	City	SFR-Basic
97 105998 RK	CITY	City	SFR-Basic
97 105997 RK	CITY	City	SFR-Basic
97 105992 RK	CITY	City	SFR-Basic
97 102864 RK	CITY	City	Single Family Res-Combo
97 102797 RK	CITY	City	Single Family Res-Combo
97 102795 RK	CITY	City	Single Family Res-Combo
97 104521 RK	F	Forestry	Single Family Res-Combo
97 108347 RK	R-5	Rural-5 Acre	Single Family Res-Combo
97 104588 MH	RD	Rural Diversification	Double Wide
97 104661 RK	R-5	Rural-5 Acre	Single Family Res-Combo
97 104682 RK	R-5	Rural-5 Acre	Single Family Res-Combo
97 101158 RK	R-7,200	Residential 7,200 sq. ft.	Single Family Res-Combo
97 105128 RK	R-7,200	Residential 7,200 sq. ft.	SFR-Basic
97 104513 RK	R-7,200	Residential 7,200 sq. ft.	Single Family Res-Combo
97 105132 RK	R-7,200	Residential 7,200 sq. ft.	SFR-Basic
97 104809 RK	RC	Rural Conservation	Single Family Res-Combo
97 103544 RK	RB	Rural Business	Single Family Res-Combo
97 104807 RK	F	Forestry	Single Family Res-Combo
97 105133 MH	A-10 : R-5	Agriculture-10 Acre : Rural-5	Double Wide
97 104633 RK	R-5	Rural-5 Acre	Single Family Res-Combo
97 104901 MH	NB	Neighborhood Business	MH Park-Double Wide
97 104903 MH	NB	Neighborhood Business	MH Park-Double Wide
97 104907 MH	CITY	City	MH Park-Double Wide
96 108405 RK	CITY	City	Single Family Res-Combo
97 106027 RK	CITY	City	Single Family Res-Combo
97 104155 RK	CITY	City	Single Family Res-Combo
97 104990 RK	R-5	Rural-5 Acre	Single Family Res-Combo
97 109484 MH	R-5	Rural-5 Acre	Double Wide
97 105068 RK	R-5	Rural-5 Acre	Single Family Res-Combo
97 109224 RK	R-8,400	Residential 8,400 sq. ft.	SFR-Basic
97 109838 RK	LDMR	Low Density Multiple Reside	SFR-Basic
97 109856 RK	LDMR	Low Density Multiple Reside	SFR-Basic
97 109867 RK	LDMR	Low Density Multiple Reside	SFR-Basic
97 109857 RK	LDMR	Low Density Multiple Reside	SFR-Basic
97 109859 RK	LDMR	Low Density Multiple Reside	SFR-Basic
97 109846 RK	LDMR	Low Density Multiple Reside	SFR-Basic
97 109860 RK	LDMR	Low Density Multiple Reside	SFR-Basic
97 109862 RK	LDMR	Low Density Multiple Reside	SFR-Basic
97 107683 RK	LDMR	Low Density Multiple Reside	SFR-Basic
97 109847 RK	LDMR	Low Density Multiple Reside	SFR-Basic



Accessory Dwelling Units

Index # - File Name: 1.0022 - Single Family Dwellings Data\_Snohomish County.pdf

97 107678 RK	LDMR	Low Density Multiple Reside	Single Family Res-Combo
97 107684 RK	LDMR	Low Density Multiple Reside	SFR-Basic
97 109848 RK	LDMR	Low Density Multiple Reside	SFR-Basic
97 109849 RK	LDMR	Low Density Multiple Reside	SFR-Basic
97 109851 RK	LDMR	Low Density Multiple Reside	SFR-Basic
97 107687 RK	LDMR	Low Density Multiple Reside	SFR-Basic
97 109852 RK	LDMR	Low Density Multiple Reside	SFR-Basic
97 110483 RK	R-5	Rural-5 Acre	SFR-Basic
97 110484 RK	R-5	Rural-5 Acre	SFR-Basic
97 108962 RK	R-5	Rural-5 Acre	SFR-Basic
97 108963 RK	R-5	Rural-5 Acre	SFR-Basic
97 108964 RK	R-5	Rural-5 Acre	SFR-Basic
97 108965 RK	R-5	Rural-5 Acre	SFR-Basic
97 110482 RK	R-5	Rural-5 Acre	SFR-Basic
97 108967 RK	R-5	Rural-5 Acre	SFR-Basic
97 108968 RK	R-5	Rural-5 Acre	SFR-Basic
97 108969 RK	R-5	Rural-5 Acre	SFR-Basic
97 108970 RK	R-5	Rural-5 Acre	SFR-Basic
97 108971 RK	R-5	Rural-5 Acre	SFR-Basic
97 108972 RK	R-5	Rural-5 Acre	SFR-Basic
97 108973 RK	R-5	Rural-5 Acre	SFR-Basic
97 108974 RK	R-5	Rural-5 Acre	SFR-Basic
97 108975 RK	R-5	Rural-5 Acre	SFR-Basic
97 108976 RK	R-5	Rural-5 Acre	SFR-Basic
97 108958 RK	R-5	Rural-5 Acre	SFR-Basic
97 109686 MH	R-5	Rural-5 Acre	Triple Wide
97 106074 RK	R-9,600	Residential 9,600 sq. ft.	Single Family Res-Combo
97 108821 RK	CITY	City	SFR-Basic
97 109099 RK	R-5	Rural-5 Acre	Single Family Res-Combo
97 110027 RK	R-5	Rural-5 Acre	Single Family Res-Combo
97 111006 RK	PRD-9,600	Residential 9,600 sq. ft.	SFR-Basic
97 110501 RK	PRD-9,600	Residential 9,600 sq. ft.	SFR-Basic
97 110503 RK	PRD-9,600	Residential 9,600 sq. ft.	SFR-Basic
97 110505 RK	PRD-9,600	Residential 9,600 sq. ft.	SFR-Basic
97 110506 RK	PRD-9,600	Residential 9,600 sq. ft.	SFR-Basic
97 110233 RK	PRD-9,600	Residential 9,600 sq. ft.	SFR-Basic
97 110235 RK	PRD-9,600	Residential 9,600 sq. ft.	SFR-Basic
97 110237 RK	PRD-9,600	Residential 9,600 sq. ft.	SFR-Basic
97 110238 RK	PRD-9,600	Residential 9,600 sq. ft.	SFR-Basic
97 110239 RK	PRD-9,600	Residential 9,600 sq. ft.	SFR-Basic
97 110240 RK	PRD-9,600	Residential 9,600 sq. ft.	SFR-Basic
97 109426 RK	PRD-9,600	Residential 9,600 sq. ft.	SFR-Basic
97 109650 RK	PRD-9,600	Residential 9,600 sq. ft.	SFR-Basic
97 109777 RK	PRD-9,600	Residential 9,600 sq. ft.	Single Family Res-Combo
97 109427 RK	PRD-9,600	Residential 9,600 sq. ft.	SFR-Basic
97 109428 RK	PRD-9,600	Residential 9,600 sq. ft.	SFR-Basic
97 109429 RK	PRD-9,600	Residential 9,600 sq. ft.	SFR-Basic

Accessory Dwelling Units

Index # - File Name: 1.0022 - Single Family Dwellings Data\_Snohomish County.pdf

97 109430 RK	PRD-9,600	Residential 9,600 sq. ft.	SFR-Basic
97 109432 RK	PRD-9,600	Residential 9,600 sq. ft.	SFR-Basic
97 109433 RK	PRD-9,600	Residential 9,600 sq. ft.	SFR-Basic
97 109434 RK	PRD-9,600	Residential 9,600 sq. ft.	SFR-Basic
97 110241 RK	PRD-9,600	Residential 9,600 sq. ft.	SFR-Basic
97 110242 RK	PRD-9,600	Residential 9,600 sq. ft.	SFR-Basic
97 110243 RK	PRD-9,600	Residential 9,600 sq. ft.	SFR-Basic
97 110244 RK	PRD-9,600	Residential 9,600 sq. ft.	SFR-Basic
97 103850 RK	R-5	Rural-5 Acre	Single Family Res-Combo
97 108490 RK	CITY	City	SFR-Basic
97 111745 RK	PRD-9,600	Residential 9,600 sq. ft.	SFR-Basic
97 111742 RK	PRD-9,600	Residential 9,600 sq. ft.	SFR-Basic
97 111746 RK	PRD-9,600	Residential 9,600 sq. ft.	SFR-Basic
97 111744 RK	PRD-9,600	Residential 9,600 sq. ft.	SFR-Basic
97 109325 RK	PRD-9,600	Residential 9,600 sq. ft.	SFR-Basic
97 108848 RK	PRD-9,600	Residential 9,600 sq. ft.	SFR-Basic
97 108854 RK	PRD-9,600	Residential 9,600 sq. ft.	SFR-Basic
97 108847 RK	PRD-9,600	Residential 9,600 sq. ft.	SFR-Basic
97 108850 RK	PRD-9,600	Residential 9,600 sq. ft.	SFR-Basic
97 108849 RK	PRD-9,600	Residential 9,600 sq. ft.	SFR-Basic
97 108855 RK	PRD-9,600	Residential 9,600 sq. ft.	SFR-Basic
97 108853 RK	PRD-9,600	Residential 9,600 sq. ft.	SFR-Basic
97 108852 RK	PRD-9,600	Residential 9,600 sq. ft.	SFR-Basic
97 108851 RK	PRD-9,600	Residential 9,600 sq. ft.	SFR-Basic
97 108639 RK	PRD-9,600	Residential 9,600 sq. ft.	SFR-Basic
97 108644 RK	PRD-9,600	Residential 9,600 sq. ft.	SFR-Basic
97 108643 RK	PRD-9,600	Residential 9,600 sq. ft.	SFR-Basic
97 108642 RK	PRD-9,600	Residential 9,600 sq. ft.	SFR-Basic
97 108641 RK	PRD-9,600	Residential 9,600 sq. ft.	SFR-Basic
97 108640 RK	PRD-9,600	Residential 9,600 sq. ft.	SFR-Basic
97 108844 RK	PRD-9,600	Residential 9,600 sq. ft.	SFR-Basic
97 108845 RK	PRD-9,600	Residential 9,600 sq. ft.	SFR-Basic
97 108846 RK	PRD-9,600	Residential 9,600 sq. ft.	SFR-Basic
97 108843 RK	PRD-9,600	Residential 9,600 sq. ft.	SFR-Basic
97 109591 RK	R-5	Rural-5 Acre	SFR-Basic
97 110717 RK	CITY	City	Duplex-Basic
97 101964 RK	CITY	City	SFR-Basic
97 110147 RK	R-8,400	Residential 8,400 sq. ft.	Single Family Res-Combo
97 102256 RK	R-8,400	Residential 8,400 sq. ft.	Single Family Res-Combo
97 103098 RK	R-8,400	Residential 8,400 sq. ft.	Single Family Res-Combo
97 111415 MH	CITY	City	MH Park-Double Wide
97 110130 RK	RB	Rural Business	Duplex-Combo
97 109677 RK	R-5	Rural-5 Acre	Single Family Res-Combo
97 109880 RK	PRD-9,600	Residential 9,600 sq. ft.	SFR-Basic
97 111186 RK	PRD-9,600	Residential 9,600 sq. ft.	SFR-Basic
97 111181 RK	PRD-9,600	Residential 9,600 sq. ft.	SFR-Basic
97 110869 RK	R-8,400	Residential 8,400 sq. ft.	Single Family Res-Combo

Accessory Dwelling Units

Index # - File Name: 1.0022 - Single Family Dwellings Data\_Snohomish County.pdf

97 111531 RK	PRD-9,600	Residential 9,600 sq. ft.	SFR-Basic
97 111530 RK	PRD-9,600	Residential 9,600 sq. ft.	SFR-Basic
97 110457 RK	PRD-9,600	Residential 9,600 sq. ft.	SFR-Basic
97 110459 RK	PRD-9,600	Residential 9,600 sq. ft.	SFR-Basic
97 111630 RK	PRD-9,600	Residential 9,600 sq. ft.	SFR-Basic
97 109881 RK	PRD-9,600	Residential 9,600 sq. ft.	SFR-Basic
97 110759 RK	PRD-9,600	Residential 9,600 sq. ft.	SFR-Basic
97 110379 RK	PRD-9,600	Residential 9,600 sq. ft.	SFR-Basic
97 110380 RK	PRD-9,600	Residential 9,600 sq. ft.	SFR-Basic
97 110758 RK	PRD-9,600	Residential 9,600 sq. ft.	SFR-Basic
97 111183 RK	PRD-9,600	Residential 9,600 sq. ft.	SFR-Basic
97 110461 RK	PRD-9,600	Residential 9,600 sq. ft.	SFR-Basic
97 110884 RK	PRD-9,600	Residential 9,600 sq. ft.	Single Family Res-Combo
97 110462 RK	PRD-9,600	Residential 9,600 sq. ft.	SFR-Basic
97 110463 RK	PRD-9,600	Residential 9,600 sq. ft.	SFR-Basic
97 110464 RK	PRD-9,600	Residential 9,600 sq. ft.	SFR-Basic
97 110035 RK	PRD-9,600	Residential 9,600 sq. ft.	Single Family Res-Combo
97 111895 RK	PRD-9,600	Residential 9,600 sq. ft.	SFR-Basic
97 110038 RK	PRD-9,600	Residential 9,600 sq. ft.	SFR-Basic
97 110225 RK	PRD-9,600	Residential 9,600 sq. ft.	SFR-Basic
97 110226 RK	PRD-9,600	Residential 9,600 sq. ft.	SFR-Basic
97 110223 RK	PRD-9,600	Residential 9,600 sq. ft.	SFR-Basic
97 110192 RK	R-5	Rural-5 Acre	SFR-Basic
97 108162 RK	R-5	Rural-5 Acre	Single Family Res-Combo
97 110196 MH	RC	Rural Conservation	Double Wide
97 110289 RK	R-5	Rural-5 Acre	Single Family Res-Combo
97 110468 RK	R-5	Rural-5 Acre	Single Family Res-Combo
97 110642 RK	R-5	Rural-5 Acre	SFR-Basic
97 100335 RK	R-5	Rural-5 Acre	Single Family Res-Combo
97 110772 RK	R-5	Rural-5 Acre	SFR-Basic
97 110775 RK	R-5	Rural-5 Acre	SFR-Basic
97 108195 RK	R-5	Rural-5 Acre	Single Family Res-Combo
97 108204 RK	CITY	City	Single Family Res-Combo
97 109483 RK	R-5	Rural-5 Acre	Single Family Res-Combo
97 108172 RK	SA-1	Suburban Agriculture-1 Acre	Single Family Res-Combo
97 108170 RK	SA-1	Suburban Agriculture-1 Acre	Single Family Res-Combo
97 108190 MH	CITY	City	Double Wide
97 108785 RK	CITY	City	Single Family Res-Combo
97 106532 MH	CITY	City	MH Park-Double Wide
97 111367 RK	CITY	City	SFR-Basic
97 110389 RK	CITY	City	SFR-Basic
97 111370 RK	CITY	City	SFR-Basic
97 109579 RK	CITY	City	SFR-Basic
97 110392 RK	CITY	City	SFR-Basic
97 110121 RK	CITY	City	SFR-Basic
97 110122 RK	CITY	City	SFR-Basic
97 110123 RK	CITY	City	SFR-Basic

Accessory Dwelling Units

Index # - File Name: 1.0022 - Single Family Dwellings Data\_Snohomish County.pdf

97 108892 RK	CITY	City	SFR-Basic
97 101501 RK	R-5	Rural-5 Acre	SFR-Basic
97 107865 MH	R-9,600	Residential 9,600 sq. ft.	Double Wide
97 110653 RK	CITY	City	SFR-Basic
97 108033 RK	R-9,600	Residential 9,600 sq. ft.	Single Family Res-Combo
97 107997 MH	RB	Rural Business	Double Wide
97 110335 RK	R-7,200	Residential 7,200 sq. ft.	SFR-Basic
97 107462 RK	R-7,200	Residential 7,200 sq. ft.	SFR-Basic
97 109605 RK	R-7,200	Residential 7,200 sq. ft.	SFR-Basic
97 107460 RK	R-7,200	Residential 7,200 sq. ft.	SFR-Basic
97 110336 RK	R-7,200	Residential 7,200 sq. ft.	SFR-Basic
97 107547 RK	A-10 : R-5	Agriculture-10 Acre : Rural-5	Single Family Res-Combo
97 108270 RK	CITY	City	Single Family Res-Combo
97 107598 RK	CITY	City	Duplex-Basic
97 107600 RK	CITY	City	Duplex-Combo
97 107599 RK	CITY	City	Duplex-Basic
97 107572 RK	R-5	Rural-5 Acre	Single Family Res-Combo
97 108536 RK	R-5	Rural-5 Acre	Single Family Res-Combo
97 107781 RK	R-8,400	Residential 8,400 sq. ft.	Duplex-Combo
97 107824 RK	R-5	Rural-5 Acre	Single Family Res-Combo
97 110655 RK	CITY	City	SFR-Basic
97 110658 RK	CITY	City	SFR-Basic
97 110657 RK	CITY	City	SFR-Basic
97 110659 RK	CITY	City	SFR-Basic
97 110118 RK	CITY	City	SFR-Basic
97 110119 RK	CITY	City	SFR-Basic
97 109577 RK	CITY	City	SFR-Basic
97 110388 RK	CITY	City	SFR-Basic
97 111371 RK	CITY	City	SFR-Basic
97 111369 RK	CITY	City	SFR-Basic
97 109576 RK	CITY	City	SFR-Basic
97 110390 RK	CITY	City	SFR-Basic
97 110391 RK	CITY	City	SFR-Basic
97 109578 RK	CITY	City	SFR-Basic
97 109352 RK	CITY	City	SFR-Basic
97 109354 RK	CITY	City	SFR-Basic
97 108901 RK	CITY	City	SFR-Basic
97 108900 RK	CITY	City	SFR-Basic
97 108899 RK	CITY	City	SFR-Basic
97 108898 RK	CITY	City	SFR-Basic
97 108897 RK	CITY	City	SFR-Basic
97 108896 RK	CITY	City	SFR-Basic
97 108895 RK	CITY	City	SFR-Basic
97 109355 RK	CITY	City	SFR-Basic
97 109356 RK	CITY	City	SFR-Basic
97 109357 RK	CITY	City	SFR-Basic
97 109358 RK	CITY	City	SFR-Basic

Accessory Dwelling Units

Index # - File Name: 1.0022 - Single Family Dwellings Data\_Snohomish County.pdf

97 107322 RK	F	Forestry	Single Family Res-Combo
97 107463 RK	R-7,200	Residential 7,200 sq. ft.	SFR-Basic
97 109606 RK	R-7,200	Residential 7,200 sq. ft.	SFR-Basic
97 107459 RK	R-7,200	Residential 7,200 sq. ft.	SFR-Basic
97 109604 RK	R-7,200	Residential 7,200 sq. ft.	SFR-Basic
97 110334 RK	R-7,200	Residential 7,200 sq. ft.	SFR-Basic
97 107465 RK	R-7,200	Residential 7,200 sq. ft.	SFR-Basic
97 105812 RK	R-7,200	Residential 7,200 sq. ft.	Single Family Res-Combo
97 107089 RK	R-7,200	Residential 7,200 sq. ft.	Single Family Res-Combo
97 107604 RK	R-8,400	Residential 8,400 sq. ft.	Duplex-Basic
97 107161 RK	R-5	Rural-5 Acre	Single Family Res-Combo
97 107846 RK	CITY	City	SFR-Basic
97 107848 RK	CITY	City	SFR-Basic
97 110263 RK	R-5	Rural-5 Acre	SFR-Basic
97 108042 RK	R-5	Rural-5 Acre	Single Family Res-Combo
97 107253 RK	R-5	Rural-5 Acre	Single Family Res-Combo
97 106775 RK	CITY	City	SFR-Basic
97 106773 RK	CITY	City	SFR-Basic
97 106770 RK	CITY	City	SFR-Basic
97 106975 RK	R-5	Rural-5 Acre	SFR-Basic
97 106768 RK	CITY	City	SFR-Basic
97 106774 RK	CITY	City	SFR-Basic
97 107246 RK	CITY	City	SFR-Basic
97 107834 RK	CITY	City	SFR-Basic
97 107836 RK	CITY	City	SFR-Basic
97 107838 RK	CITY	City	SFR-Basic
97 107840 RK	CITY	City	SFR-Basic
97 107248 RK	CITY	City	SFR-Basic
97 107844 RK	CITY	City	SFR-Basic
97 107522 RK	R-5	Rural-5 Acre	Single Family Res-Combo
97 107443 RK	R-5	Rural-5 Acre	Single Family Res-Combo
97 107523 RK	R-5	Rural-5 Acre	Single Family Res-Combo
97 107442 RK	R-5	Rural-5 Acre	Single Family Res-Combo
97 109040 RK	PRD-9,600	Residential 9,600 sq. ft.	SFR-Basic
97 109039 RK	PRD-9,600	Residential 9,600 sq. ft.	SFR-Basic
97 106905 MH	R-12,500	Residential 12,500 sq. ft.	Double Wide
97 110318 RK	R-5	Rural-5 Acre	Single Family Res-Combo
97 106919 MH	NB	Neighborhood Business	MH Park-Double Wide
97 106928 MH	MHP	Mobile Home Park	MH Park-Single Wide
97 106977 MH	R-5	Rural-5 Acre	Double Wide
97 106973 MH	R-5	Rural-5 Acre	Double Wide
97 106978 RK	R-5	Rural-5 Acre	SFR-Basic
97 107596 RK	CITY	City	Single Family Res-Combo
97 107033 MH	R-5	Rural-5 Acre	Double Wide
97 106969 MH	R-5	Rural-5 Acre	Single Wide
97 107104 MH	CITY	City	MH Park-Double Wide
97 107239 RK	R-7,200	Residential 7,200 sq. ft.	Single Family Res-Combo

Accessory Dwelling Units

Index # - File Name: 1.0022 - Single Family Dwellings Data\_Snohomish County.pdf

97 107240 RK	R-7,200	Residential 7,200 sq. ft.	Single Family Res-Combo
97 107238 RK	R-7,200	Residential 7,200 sq. ft.	Single Family Res-Combo
97 107791 RK	R-5	Rural-5 Acre	Single Family Res-Combo
97 107134 RK	R-5	Rural-5 Acre	Single Family Res-Combo
97 109350 RK	CITY	City	Single Family Res-Combo
97 110714 RK	R-9,600	Residential 9,600 sq. ft.	Single Family Res-Combo
97 110969 RK	R-5	Rural-5 Acre	SFR-Basic
97 110971 RK	R-5	Rural-5 Acre	SFR-Basic
97 110941 RK	LDMR	Low Density Multiple Reside	Single Family Res-Combo
97 110206 RK	R-8,400	Residential 8,400 sq. ft.	Single Family Res-Combo
97 110203 RK	R-8,400	Residential 8,400 sq. ft.	Single Family Res-Combo
97 110773 RK	R-5	Rural-5 Acre	SFR-Basic
97 110958 RK	R-5	Rural-5 Acre	SFR-Basic
97 108237 RK	R-9,600	Residential 9,600 sq. ft.	Single Family Res-Combo
97 108236 RK	R-9,600	Residential 9,600 sq. ft.	Single Family Res-Combo
97 110723 RK	R-9,600	Residential 9,600 sq. ft.	Single Family Res-Combo
97 107556 RK	PRD-9,600	Residential 9,600 sq. ft.	Single Family Res-Combo
97 107551 RK	PRD-9,600	Residential 9,600 sq. ft.	Single Family Res-Combo
97 107553 RK	PRD-9,600	Residential 9,600 sq. ft.	Single Family Res-Combo
97 106949 RK	PRD-9,600	Residential 9,600 sq. ft.	Single Family Res-Combo
97 106948 RK	PRD-9,600	Residential 9,600 sq. ft.	Single Family Res-Combo
97 106947 RK	PRD-9,600	Residential 9,600 sq. ft.	Single Family Res-Combo
97 106951 RK	PRD-9,600	Residential 9,600 sq. ft.	Single Family Res-Combo
97 106901 RK	PRD-9,600	Residential 9,600 sq. ft.	Single Family Res-Combo
97 106903 RK	PRD-9,600	Residential 9,600 sq. ft.	Single Family Res-Combo
97 108300 RK	R-9,600	Residential 9,600 sq. ft.	Single Family Res-Combo
97 108442 RK	R-9,600	Residential 9,600 sq. ft.	Single Family Res-Combo
97 105226 RK	R-5	Rural-5 Acre	Single Family Res-Combo
97 109889 RK	R-5	Rural-5 Acre	Single Family Res-Combo
97 105838 RK	R-5	Rural-5 Acre	Single Family Res-Combo
97 109826 RK	R-5	Rural-5 Acre	Single Family Res-Combo
98 116909 RK	R-5	Rural-5 Acre	Single Family Res-Combo
98 116583 RK	R-5	Rural-5 Acre	Single Family Res-Combo
98 110644 RK	R-5	Rural-5 Acre	Single Family Res-Combo
98 116117 RK	PRD-7,200	Residential 7,200 sq. ft.	Single Family Res-Combo
98 116269 RK	PRD-7,200	Residential 7,200 sq. ft.	Single Family Res-Combo
98 116271 RK	PRD-7,200	Residential 7,200 sq. ft.	Single Family Res-Combo
98 116266 RK	PRD-7,200	Residential 7,200 sq. ft.	Single Family Res-Combo
98 116273 RK	PRD-7,200	Residential 7,200 sq. ft.	Single Family Res-Combo
98 116115 RK	PRD-7,200	Residential 7,200 sq. ft.	Single Family Res-Combo
98 116882 MH	PRD-12,500(M	Residential 12,500 sq. ft.	Double Wide
98 150625 MH	MR	Multiple Residential	Double Wide
98 110640 RK	R-5	Rural-5 Acre	Single Family Res-Combo
98 150507 RK	CITY	City	Single Family Res-Combo
98 110608 RK	R-8,400	Residential 8,400 sq. ft.	Duplex-Basic
98 110612 RK	R-8,400	Residential 8,400 sq. ft.	Duplex-Basic
97 111707 RK	R-5	Rural-5 Acre	Single Family Res-Combo

Accessory Dwelling Units

Index # - File Name: 1.0022 - Single Family Dwellings Data\_Snohomish County.pdf

98 101562 RK	R-5	Rural-5 Acre	Single Family Res-Combo
98 110301 RK	R-5	Rural-5 Acre	Single Family Res-Combo
98 109442 RK	PRD-7,200	Residential 7,200 sq. ft.	Single Family Res-Combo
98 109838 RK	PRD-7,200	Residential 7,200 sq. ft.	Single Family Res-Combo
98 117039 RK	PRD-7,200	Residential 7,200 sq. ft.	SFR-Basic
98 117041 RK	PRD-7,200	Residential 7,200 sq. ft.	SFR-Basic
98 117043 RK	PRD-7,200	Residential 7,200 sq. ft.	SFR-Basic
98 117044 RK	PRD-7,200	Residential 7,200 sq. ft.	SFR-Basic
98 117045 RK	PRD-7,200	Residential 7,200 sq. ft.	SFR-Basic
98 117046 RK	PRD-7,200	Residential 7,200 sq. ft.	SFR-Basic
98 117047 RK	PRD-7,200	Residential 7,200 sq. ft.	SFR-Basic
98 110711 RK	R-5	Rural-5 Acre	Single Family Res-Combo
98 110713 RK	R-5	Rural-5 Acre	Single Family Res-Combo
98 110712 RK	R-5	Rural-5 Acre	Single Family Res-Combo
98 108555 RK	R-5	Rural-5 Acre	Single Family Res-Combo
98 110386 MH	R-5	Rural-5 Acre	Double Wide
98 116445 MH	R-5	Rural-5 Acre	Double Wide
98 116654 RK	PRD-7,200	Residential 7,200 sq. ft.	Single Family Res-Combo
98 116420 RK	PRD-7,200	Residential 7,200 sq. ft.	Single Family Res-Combo
98 110721 RK	PRD-7,200	Residential 7,200 sq. ft.	Single Family Res-Combo
98 117024 RK	R-7,200	Residential 7,200 sq. ft.	Duplex-Basic
98 117025 RK	R-7,200	Residential 7,200 sq. ft.	Duplex-Basic
98 117026 RK	R-7,200	Residential 7,200 sq. ft.	Duplex-Basic
98 116421 RK	PRD-7,200	Residential 7,200 sq. ft.	Single Family Res-Combo
98 109628 RK	R-5	Rural-5 Acre	Single Family Res-Combo
98 116869 RK	CITY	City	SFR-Basic
98 116870 RK	CITY	City	SFR-Basic
98 116871 RK	CITY	City	SFR-Basic
98 116872 RK	CITY	City	SFR-Basic
98 116864 RK	CITY	City	SFR-Basic
98 116865 RK	CITY	City	SFR-Basic
98 116866 RK	CITY	City	SFR-Basic
98 116867 RK	CITY	City	SFR-Basic
98 116895 RK	R-9,600	Residential 9,600 sq. ft.	SFR-Basic
98 100517 RK	R-5	Rural-5 Acre	Single Family Res-Combo
98 116976 RK	UC	Urban Center	Duplex-Combo
98 117068 RK	PRD-9,600	Residential 9,600 sq. ft.	SFR-Basic
98 117027 RK	R-7,200	Residential 7,200 sq. ft.	Duplex-Basic
98 117066 RK	PRD-9,600	Residential 9,600 sq. ft.	SFR-Basic
98 108019 RK	PRD-9,600	Residential 9,600 sq. ft.	Single Family Res-Combo
98 109932 RK	PRD-9,600	Residential 9,600 sq. ft.	Single Family Res-Combo
98 109933 RK	PRD-9,600	Residential 9,600 sq. ft.	Single Family Res-Combo
98 116444 RK	PRD-9,600	Residential 9,600 sq. ft.	Single Family Res-Combo
98 116442 RK	PRD-9,600	Residential 9,600 sq. ft.	Single Family Res-Combo
98 116250 RK	PRD-9,600	Residential 9,600 sq. ft.	Single Family Res-Combo
98 150567 RK	PRD-9,600	Residential 9,600 sq. ft.	SFR-Basic
98 108758 RK	PRD-9,600	Residential 9,600 sq. ft.	Single Family Res-Combo

Accessory Dwelling Units

Index # - File Name: 1.0022 - Single Family Dwellings Data\_Snohomish County.pdf

98 150672 RK	PRD-9,600	Residential 9,600 sq. ft.	SFR-Basic
98 150834 RK	PRD-9,600	Residential 9,600 sq. ft.	SFR-Basic
98 150835 RK	PRD-9,600	Residential 9,600 sq. ft.	SFR-Basic
98 150836 RK	PRD-9,600	Residential 9,600 sq. ft.	SFR-Basic
98 150837 RK	PRD-9,600	Residential 9,600 sq. ft.	SFR-Basic
98 150838 RK	PRD-9,600	Residential 9,600 sq. ft.	SFR-Basic
98 150840 RK	PRD-9,600	Residential 9,600 sq. ft.	SFR-Basic
98 150841 RK	PRD-9,600	Residential 9,600 sq. ft.	SFR-Basic
98 150842 RK	PRD-9,600	Residential 9,600 sq. ft.	SFR-Basic
98 150843 RK	PRD-9,600	Residential 9,600 sq. ft.	SFR-Basic
98 150844 RK	PRD-9,600	Residential 9,600 sq. ft.	SFR-Basic
98 150846 RK	PRD-9,600	Residential 9,600 sq. ft.	SFR-Basic
98 150847 RK	PRD-9,600	Residential 9,600 sq. ft.	SFR-Basic
98 150674 RK	PRD-9,600	Residential 9,600 sq. ft.	SFR-Basic
98 150675 RK	PRD-9,600	Residential 9,600 sq. ft.	SFR-Basic
98 150676 RK	PRD-9,600	Residential 9,600 sq. ft.	SFR-Basic
98 150677 RK	PRD-9,600	Residential 9,600 sq. ft.	SFR-Basic
98 150679 RK	PRD-9,600	Residential 9,600 sq. ft.	SFR-Basic
98 150680 RK	PRD-9,600	Residential 9,600 sq. ft.	SFR-Basic
98 150681 RK	PRD-9,600	Residential 9,600 sq. ft.	SFR-Basic
98 150683 RK	PRD-9,600	Residential 9,600 sq. ft.	SFR-Basic
98 150777 MH	CITY	City	Double Wide
98 151158 MH	MHP	Mobile Home Park	Single Wide
98 151160 MH	MHP	Mobile Home Park	MH Park-Single Wide
98 107212 RK	PRD-9,600	Residential 9,600 sq. ft.	SFR-Basic
98 107217 RK	PRD-9,600	Residential 9,600 sq. ft.	SFR-Basic
98 107211 RK	PRD-9,600	Residential 9,600 sq. ft.	SFR-Basic
98 116044 RK	PRD-9,600	Residential 9,600 sq. ft.	SFR-Basic
98 108066 RK	PRD-9,600	Residential 9,600 sq. ft.	SFR-Basic
98 110102 RK	PRD-9,600	Residential 9,600 sq. ft.	SFR-Basic
98 108068 RK	PRD-9,600	Residential 9,600 sq. ft.	SFR-Basic
98 108069 RK	PRD-9,600	Residential 9,600 sq. ft.	SFR-Basic
98 108070 RK	PRD-9,600	Residential 9,600 sq. ft.	SFR-Basic
98 108071 RK	PRD-9,600	Residential 9,600 sq. ft.	SFR-Basic
98 116101 RK	PRD-9,600	Residential 9,600 sq. ft.	Single Family Res-Combo
98 108073 RK	PRD-9,600	Residential 9,600 sq. ft.	SFR-Basic
98 108077 RK	PRD-9,600	Residential 9,600 sq. ft.	SFR-Basic
98 108078 RK	PRD-9,600	Residential 9,600 sq. ft.	SFR-Basic
98 150708 RK	PRD-9,600	Residential 9,600 sq. ft.	SFR-Basic
98 150709 RK	PRD-9,600	Residential 9,600 sq. ft.	SFR-Basic
98 150710 RK	PRD-9,600	Residential 9,600 sq. ft.	SFR-Basic
98 106474 MH	SA-1	Suburban Agriculture-1 Acre	Double Wide
98 106467 RK	R-9,600	Residential 9,600 sq. ft.	Single Family Res-Combo
98 106631 RK	R-5	Rural-5 Acre	Single Family Res-Combo
98 109815 RK	CITY	City	Single Family Res-Combo
98 150712 RK	PRD-9,600	Residential 9,600 sq. ft.	SFR-Basic
98 150713 RK	PRD-9,600	Residential 9,600 sq. ft.	SFR-Basic



Accessory Dwelling Units

Index # - File Name: 1.0022 - Single Family Dwellings Data\_Snohomish County.pdf

98 150714 RK	PRD-9,600	Residential 9,600 sq. ft.	SFR-Basic
98 150717 RK	PRD-9,600	Residential 9,600 sq. ft.	SFR-Basic
98 116885 RK	PRD-9,600	Residential 9,600 sq. ft.	SFR-Basic
98 116886 RK	PRD-9,600	Residential 9,600 sq. ft.	SFR-Basic
98 116887 RK	PRD-9,600	Residential 9,600 sq. ft.	SFR-Basic
98 116888 RK	PRD-9,600	Residential 9,600 sq. ft.	SFR-Basic
98 116889 RK	PRD-9,600	Residential 9,600 sq. ft.	SFR-Basic
98 150718 RK	PRD-9,600	Residential 9,600 sq. ft.	SFR-Basic
98 116890 RK	PRD-9,600	Residential 9,600 sq. ft.	SFR-Basic
98 116891 RK	PRD-9,600	Residential 9,600 sq. ft.	SFR-Basic
98 116893 RK	PRD-9,600	Residential 9,600 sq. ft.	SFR-Basic
98 116894 RK	PRD-9,600	Residential 9,600 sq. ft.	SFR-Basic
98 108079 RK	PRD-9,600	Residential 9,600 sq. ft.	SFR-Basic
98 108080 RK	PRD-9,600	Residential 9,600 sq. ft.	SFR-Basic
98 108081 RK	PRD-9,600	Residential 9,600 sq. ft.	SFR-Basic
98 108082 RK	PRD-9,600	Residential 9,600 sq. ft.	SFR-Basic
98 108083 RK	PRD-9,600	Residential 9,600 sq. ft.	SFR-Basic
98 150719 RK	PRD-9,600	Residential 9,600 sq. ft.	SFR-Basic
98 105390 RK	PRD-9,600	Residential 9,600 sq. ft.	Single Family Res-Combo
98 105393 RK	PRD-9,600	Residential 9,600 sq. ft.	Single Family Res-Combo
98 105394 RK	PRD-9,600	Residential 9,600 sq. ft.	Single Family Res-Combo
98 106864 RK	PRD-9,600	Residential 9,600 sq. ft.	SFR-Basic
98 106860 RK	PRD-9,600	Residential 9,600 sq. ft.	SFR-Basic
98 105396 RK	PRD-9,600	Residential 9,600 sq. ft.	Single Family Res-Combo
98 106874 RK	PRD-9,600	Residential 9,600 sq. ft.	SFR-Basic
98 106868 RK	PRD-9,600	Residential 9,600 sq. ft.	SFR-Basic
98 106873 RK	PRD-9,600	Residential 9,600 sq. ft.	SFR-Basic
98 107218 RK	PRD-9,600	Residential 9,600 sq. ft.	SFR-Basic
98 107214 RK	PRD-9,600	Residential 9,600 sq. ft.	SFR-Basic
98 107209 RK	PRD-9,600	Residential 9,600 sq. ft.	SFR-Basic
98 107210 RK	PRD-9,600	Residential 9,600 sq. ft.	SFR-Basic
98 109220 RK	PRD-9,600	Residential 9,600 sq. ft.	SFR-Basic
98 109223 RK	PRD-9,600	Residential 9,600 sq. ft.	SFR-Basic
98 110025 RK	PRD-9,600	Residential 9,600 sq. ft.	SFR-Basic
98 109221 RK	PRD-9,600	Residential 9,600 sq. ft.	SFR-Basic
98 107206 RK	PRD-9,600	Residential 9,600 sq. ft.	SFR-Basic
98 107207 RK	PRD-9,600	Residential 9,600 sq. ft.	SFR-Basic
98 107215 RK	PRD-9,600	Residential 9,600 sq. ft.	SFR-Basic
98 106764 RK	R-5	Rural-5 Acre	Single Family Res-Combo
98 106810 RK	CITY	City	Single Family Res-Combo
98 107777 RK	R-5	Rural-5 Acre	Single Family Res-Combo
98 100595 RK	R-5	Rural-5 Acre	Single Family Res-Combo
98 106819 MH	R-5	Rural-5 Acre	Double Wide
98 106958 RK	R-5	Rural-5 Acre	Single Family Res-Combo
98 106980 RK	R-9,600	Residential 9,600 sq. ft.	Single Family Res-Combo
98 107010 MH	R-5	Rural-5 Acre	Double Wide
98 102255 RK	R-5	Rural-5 Acre	Single Family Res-Combo

Accessory Dwelling Units

Index # - File Name: 1.0022 - Single Family Dwellings Data\_Snohomish County.pdf

98 109512 RK	PRD-9,600	Residential 9,600 sq. ft.	SFR-Basic
98 110340 RK	PRD-9,600	Residential 9,600 sq. ft.	SFR-Basic
98 109063 RK	PRD-9,600	Residential 9,600 sq. ft.	SFR-Basic
98 108360 RK	PRD-9,600	Residential 9,600 sq. ft.	SFR-Basic
98 106782 RK	PRD-9,600	Residential 9,600 sq. ft.	Single Family Res-Combo
98 106791 RK	PRD-9,600	Residential 9,600 sq. ft.	Single Family Res-Combo
98 106332 RK	PRD-9,600	Residential 9,600 sq. ft.	Single Family Res-Combo
98 107707 RK	PRD-9,600	Residential 9,600 sq. ft.	SFR-Basic
98 107706 RK	PRD-9,600	Residential 9,600 sq. ft.	SFR-Basic
98 108366 RK	PRD-9,600	Residential 9,600 sq. ft.	SFR-Basic
98 108365 RK	PRD-9,600	Residential 9,600 sq. ft.	SFR-Basic
98 103256 RK	PRD-9,600	Residential 9,600 sq. ft.	Single Family Res-Combo
98 103258 RK	PRD-9,600	Residential 9,600 sq. ft.	Single Family Res-Combo
98 108362 RK	PRD-9,600	Residential 9,600 sq. ft.	SFR-Basic
98 109146 RK	PRD-9,600	Residential 9,600 sq. ft.	Single Family Res-Combo
98 103254 RK	PRD-9,600	Residential 9,600 sq. ft.	Single Family Res-Combo
98 103255 RK	PRD-9,600	Residential 9,600 sq. ft.	Single Family Res-Combo
98 107145 MH	R-5	Rural-5 Acre	Double Wide
98 107223 MH	R-5	Rural-5 Acre	Double Wide
98 107433 RK	CITY	City	Single Family Res-Combo
98 107434 RK	CITY	City	Single Family Res-Combo
98 107410 RK	CITY	City	Single Family Res-Combo
98 107411 RK	CITY	City	Single Family Res-Combo
98 107412 RK	CITY	City	Single Family Res-Combo
98 107413 RK	CITY	City	Single Family Res-Combo
98 107435 RK	CITY	City	Single Family Res-Combo
98 107436 RK	CITY	City	Single Family Res-Combo
98 107414 RK	CITY	City	Single Family Res-Combo
98 107415 RK	CITY	City	Single Family Res-Combo
98 107416 RK	CITY	City	Single Family Res-Combo
98 107417 RK	CITY	City	Single Family Res-Combo
98 107427 RK	CITY	City	Single Family Res-Combo
98 107428 RK	CITY	City	Single Family Res-Combo
98 107437 RK	CITY	City	Single Family Res-Combo
98 107438 RK	CITY	City	Single Family Res-Combo
98 107403 RK	CITY	City	Single Family Res-Combo
98 107404 RK	CITY	City	Single Family Res-Combo
98 107418 RK	CITY	City	Single Family Res-Combo
98 107419 RK	CITY	City	Single Family Res-Combo
98 107405 RK	CITY	City	Single Family Res-Combo
98 107407 RK	CITY	City	Single Family Res-Combo
98 107400 RK	CITY	City	Single Family Res-Combo
98 107402 RK	CITY	City	Single Family Res-Combo
98 107421 RK	CITY	City	Single Family Res-Combo
98 107422 RK	CITY	City	Single Family Res-Combo
98 107423 RK	CITY	City	Single Family Res-Combo
98 107424 RK	CITY	City	Single Family Res-Combo

Accessory Dwelling Units

Index # - File Name: 1.0022 - Single Family Dwellings Data\_Snohomish County.pdf

98 107429 RK	CITY	City	Single Family Res-Combo
98 107430 RK	CITY	City	Single Family Res-Combo
98 107425 RK	CITY	City	Single Family Res-Combo
98 107426 RK	CITY	City	Single Family Res-Combo
98 107431 RK	CITY	City	Single Family Res-Combo
98 107432 RK	CITY	City	Single Family Res-Combo
98 107408 RK	CITY	City	Single Family Res-Combo
98 107409 RK	CITY	City	Single Family Res-Combo
98 107238 MH	F	Forestry	Double Wide
98 107243 RK	A-10 : R-5	Agriculture-10 Acre : Rural-5	Single Family Res-Combo
98 110339 RK	PRD-9,600	Residential 9,600 sq. ft.	SFR-Basic
98 110696 RK	PRD-9,600	Residential 9,600 sq. ft.	Single Family Res-Combo
98 109064 RK	PRD-9,600	Residential 9,600 sq. ft.	SFR-Basic
98 107704 RK	R-5	Rural-5 Acre	Single Family Res-Combo
98 107439 RK	R-5	Rural-5 Acre	Single Family Res-Combo
98 108669 RK	CITY	City	Single Family Res-Combo
98 107548 RK	CITY	City	Single Family Res-Combo
98 108662 RK	CITY	City	Single Family Res-Combo
98 107545 RK	CITY	City	Single Family Res-Combo
98 116246 RK	CITY	City	SFR-Basic
98 116715 RK	CITY	City	SFR-Basic
98 116242 RK	CITY	City	SFR-Basic
98 116244 RK	CITY	City	SFR-Basic
98 116240 RK	CITY	City	SFR-Basic
98 108665 RK	CITY	City	Single Family Res-Combo
98 107584 RK	CITY	City	Single Family Res-Combo
98 107567 RK	CITY	City	Single Family Res-Combo
98 108663 RK	CITY	City	Single Family Res-Combo
98 107577 RK	CITY	City	Single Family Res-Combo
98 108670 RK	CITY	City	Single Family Res-Combo
98 116716 RK	CITY	City	SFR-Basic
98 108667 RK	CITY	City	Single Family Res-Combo
98 108671 RK	CITY	City	Single Family Res-Combo
98 107583 RK	CITY	City	Single Family Res-Combo
98 107580 RK	CITY	City	Single Family Res-Combo
98 107578 RK	CITY	City	Single Family Res-Combo
98 116712 RK	CITY	City	SFR-Basic
98 116720 RK	CITY	City	Single Family Res-Combo
98 116717 RK	CITY	City	Single Family Res-Combo
98 116719 RK	CITY	City	Single Family Res-Combo
98 109195 RK	R-7,200	Residential 7,200 sq. ft.	SFR-Basic
98 108153 RK	R-7,200	Residential 7,200 sq. ft.	SFR-Basic
98 108141 RK	R-7,200	Residential 7,200 sq. ft.	SFR-Basic
98 109218 RK	R-7,200	Residential 7,200 sq. ft.	SFR-Basic
98 108142 RK	R-7,200	Residential 7,200 sq. ft.	SFR-Basic
98 106715 RK	R-7,200	Residential 7,200 sq. ft.	Single Family Res-Combo
98 108143 RK	R-7,200	Residential 7,200 sq. ft.	SFR-Basic

Accessory Dwelling Units

Index # - File Name: 1.0022 - Single Family Dwellings Data\_Snohomish County.pdf

98 108144 RK	R-7,200	Residential 7,200 sq. ft.	SFR-Basic
98 109192 RK	R-7,200	Residential 7,200 sq. ft.	SFR-Basic
98 108145 RK	R-7,200	Residential 7,200 sq. ft.	SFR-Basic
98 107738 RK	R-7,200	Residential 7,200 sq. ft.	Single Family Res-Combo
98 108146 RK	R-7,200	Residential 7,200 sq. ft.	SFR-Basic
98 108147 RK	R-7,200	Residential 7,200 sq. ft.	SFR-Basic
98 108148 RK	R-7,200	Residential 7,200 sq. ft.	SFR-Basic
98 106671 RK	R-7,200	Residential 7,200 sq. ft.	Single Family Res-Combo
98 108149 RK	R-7,200	Residential 7,200 sq. ft.	SFR-Basic
98 106667 RK	R-7,200	Residential 7,200 sq. ft.	Single Family Res-Combo
98 108150 RK	R-7,200	Residential 7,200 sq. ft.	SFR-Basic
98 107320 RK	R-8,400	Residential 8,400 sq. ft.	Single Family Res-Combo
98 107989 RK	CITY	City	Single Family Res-Combo
98 107987 RK	CITY	City	Single Family Res-Combo
98 116243 RK	CITY	City	SFR-Basic
98 116825 RK	CITY	City	SFR-Basic
98 116200 RK	CITY	City	SFR-Basic
98 116201 RK	CITY	City	SFR-Basic
98 116827 RK	CITY	City	SFR-Basic
98 116823 RK	CITY	City	SFR-Basic
98 116824 RK	CITY	City	SFR-Basic
98 109409 RK	CITY	City	SFR-Basic
98 109411 RK	CITY	City	SFR-Basic
98 116520 RK	CITY	City	SFR-Basic
98 116202 RK	CITY	City	SFR-Basic
98 116199 RK	CITY	City	SFR-Basic
98 109407 RK	CITY	City	Single Family Res-Combo
98 110688 RK	CITY	City	SFR-Basic
98 110492 RK	CITY	City	SFR-Basic
98 110497 RK	CITY	City	SFR-Basic
98 110689 RK	CITY	City	SFR-Basic
98 110690 RK	CITY	City	Single Family Res-Combo
98 108986 RK	T	Townhouse	SFR-Basic
98 108987 RK	T	Townhouse	SFR-Basic
98 108988 RK	T	Townhouse	SFR-Basic
98 108989 RK	T	Townhouse	SFR-Basic
98 108897 MH	F	Forestry	Double Wide
98 107805 RK	R-5	Rural-5 Acre	Single Family Res-Combo
97 109603 RK	CITY	City	Duplex-Combo
97 103928 RK	CITY	City	Duplex-Combo
98 107813 RK	R-5	Rural-5 Acre	Single Family Res-Combo
98 109352 RK	R-5	Rural-5 Acre	Single Family Res-Combo
98 107123 RK	R-5	Rural-5 Acre	Single Family Res-Combo
98 107866 RK	R-5	Rural-5 Acre	Single Family Res-Combo
98 109143 MH	R-5	Rural-5 Acre	Double Wide
98 107924 MH	MHP	Mobile Home Park	MH Park-Single Wide
98 104463 RK	R-5	Rural-5 Acre	Single Family Res-Combo

Accessory Dwelling Units

Index # - File Name: 1.0022 - Single Family Dwellings Data\_Snohomish County.pdf

98 105989 RK	T	Townhouse	Single Family Res-Combo
98 107785 RK	T	Townhouse	SFR-Basic
98 105998 RK	T	Townhouse	Single Family Res-Combo
98 107787 RK	T	Townhouse	SFR-Basic
98 106002 RK	T	Townhouse	Single Family Res-Combo
98 108504 RK	T	Townhouse	SFR-Basic
98 108500 RK	T	Townhouse	SFR-Basic
98 108499 RK	T	Townhouse	SFR-Basic
98 109903 RK	R-9,600	Residential 9,600 sq. ft.	Single Family Res-Combo
98 107961 MH	R-5	Rural-5 Acre	Double Wide
98 108157 RK	R-5	Rural-5 Acre	Single Family Res-Combo
98 108792 RK	R-7,200	Residential 7,200 sq. ft.	Single Family Res-Combo
98 116325 RK	R-7,200	Residential 7,200 sq. ft.	SFR-Basic
98 109160 RK	R-7,200	Residential 7,200 sq. ft.	Single Family Res-Combo
98 150525 RK	R-7,200	Residential 7,200 sq. ft.	Single Family Res-Combo
98 109165 RK	R-7,200	Residential 7,200 sq. ft.	Single Family Res-Combo
98 108871 RK	R-7,200	Residential 7,200 sq. ft.	Single Family Res-Combo
98 108033 MH	R-5	Rural-5 Acre	Double Wide
98 116323 RK	R-7,200	Residential 7,200 sq. ft.	Single Family Res-Combo
98 109996 RK	R-7,200	Residential 7,200 sq. ft.	Single Family Res-Combo
98 109172 RK	R-7,200	Residential 7,200 sq. ft.	Single Family Res-Combo
98 150529 RK	R-7,200	Residential 7,200 sq. ft.	SFR-Basic
98 108240 RK	R-5	Rural-5 Acre	Single Family Res-Combo
98 108296 RK	R-5	Rural-5 Acre	Single Family Res-Combo
98 110355 RK	R-7,200	Residential 7,200 sq. ft.	SFR-Basic
98 108734 MH	R-5	Rural-5 Acre	Single Wide
98 108634 RK	R-5	Rural-5 Acre	Single Family Res-Combo
98 108694 MH	R-5	Rural-5 Acre	Double Wide
98 110697 RK	R-9,600	Residential 9,600 sq. ft.	SFR-Basic
98 108405 RK	R-9,600	Residential 9,600 sq. ft.	Single Family Res-Combo
98 116189 RK	R-9,600	Residential 9,600 sq. ft.	Single Family Res-Combo
98 108099 RK	R-9,600	Residential 9,600 sq. ft.	Single Family Res-Combo
98 110698 RK	R-9,600	Residential 9,600 sq. ft.	SFR-Basic
98 116815 RK	R-9,600	Residential 9,600 sq. ft.	SFR-Basic
98 116539 RK	R-9,600	Residential 9,600 sq. ft.	SFR-Basic
98 108436 RK	CITY	City	Single Family Res-Combo
98 108443 MH	CITY	City	Double Wide
98 117054 RK	R-9,600	Residential 9,600 sq. ft.	SFR-Basic
98 117052 RK	R-9,600	Residential 9,600 sq. ft.	SFR-Basic
98 116540 RK	R-9,600	Residential 9,600 sq. ft.	SFR-Basic
98 110701 RK	R-9,600	Residential 9,600 sq. ft.	SFR-Basic
98 110700 RK	R-9,600	Residential 9,600 sq. ft.	SFR-Basic
98 110703 RK	R-9,600	Residential 9,600 sq. ft.	SFR-Basic
98 108407 RK	R-9,600	Residential 9,600 sq. ft.	Single Family Res-Combo
98 116541 RK	R-9,600	Residential 9,600 sq. ft.	SFR-Basic
98 110702 RK	R-9,600	Residential 9,600 sq. ft.	SFR-Basic
98 110704 RK	R-9,600	Residential 9,600 sq. ft.	SFR-Basic

Accessory Dwelling Units

Index # - File Name: 1.0022 - Single Family Dwellings Data\_Snohomish County.pdf

98 108858 RK	R-5	Rural-5 Acre	Single Family Res-Combo
98 108861 RK	R-5	Rural-5 Acre	Single Family Res-Combo
98 108884 RK	R-7,200	Residential 7,200 sq. ft.	Single Family Res-Combo
98 108982 RK	R-5	Rural-5 Acre	SFR-Basic
98 109271 MH	A-10	Agriculture-10 Acre	Double Wide
98 103417 RK	R-5	Rural-5 Acre	Single Family Res-Combo
98 109651 RK	R-5	Rural-5 Acre	Single Family Res-Combo
98 109262 RK	R-5	Rural-5 Acre	Single Family Res-Combo
98 108932 RK	R-5	Rural-5 Acre	Single Family Res-Combo
98 108333 RK	R-7,200	Residential 7,200 sq. ft.	Single Family Res-Combo
98 109316 RK	R-7,200	Residential 7,200 sq. ft.	SFR-Basic
98 109305 RK	R-7,200	Residential 7,200 sq. ft.	SFR-Basic
98 108809 RK	R-7,200	Residential 7,200 sq. ft.	Single Family Res-Combo
98 108807 RK	R-7,200	Residential 7,200 sq. ft.	Single Family Res-Combo
98 108808 RK	R-7,200	Residential 7,200 sq. ft.	Single Family Res-Combo
98 110179 RK	R-7,200	Residential 7,200 sq. ft.	SFR-Basic
98 109304 RK	R-7,200	Residential 7,200 sq. ft.	SFR-Basic
98 109317 RK	R-7,200	Residential 7,200 sq. ft.	SFR-Basic
98 109318 RK	R-7,200	Residential 7,200 sq. ft.	SFR-Basic
98 109307 RK	R-7,200	Residential 7,200 sq. ft.	SFR-Basic
98 110182 RK	R-7,200	Residential 7,200 sq. ft.	SFR-Basic
98 109308 RK	R-7,200	Residential 7,200 sq. ft.	SFR-Basic
98 109319 RK	R-7,200	Residential 7,200 sq. ft.	SFR-Basic
98 109320 RK	R-7,200	Residential 7,200 sq. ft.	SFR-Basic
98 108336 RK	R-7,200	Residential 7,200 sq. ft.	Single Family Res-Combo
98 110180 RK	R-7,200	Residential 7,200 sq. ft.	SFR-Basic
98 109310 RK	R-7,200	Residential 7,200 sq. ft.	SFR-Basic
98 110620 RK	R-7,200	Residential 7,200 sq. ft.	SFR-Basic
98 109311 RK	R-7,200	Residential 7,200 sq. ft.	SFR-Basic
98 109312 RK	R-7,200	Residential 7,200 sq. ft.	SFR-Basic
98 109313 RK	R-7,200	Residential 7,200 sq. ft.	SFR-Basic
98 106587 RK	R-7,200	Residential 7,200 sq. ft.	Single Family Res-Combo
98 106585 RK	R-7,200	Residential 7,200 sq. ft.	Single Family Res-Combo
98 109279 RK	CITY	City	Single Family Res-Combo
98 109285 RK	CITY	City	Duplex-Combo
98 106584 RK	R-7,200	Residential 7,200 sq. ft.	Single Family Res-Combo
98 109144 RK	PRD-7,200	Residential 7,200 sq. ft.	Single Family Res-Combo
98 109482 MH	RRT-10	Rural Resource Transition-10	Single Wide
98 101421 RK	PRD-9,600	Residential 9,600 sq. ft.	Single Family Res-Combo
98 101419 RK	PRD-9,600	Residential 9,600 sq. ft.	Single Family Res-Combo
98 109551 RK	R-5	Rural-5 Acre	Single Family Res-Combo
98 109546 RK	R-5	Rural-5 Acre	Single Family Res-Combo
98 108518 RK	R-5	Rural-5 Acre	Accessory Apt Detached-Combo
98 116566 RK	PRD-9,600	Residential 9,600 sq. ft.	SFR-Basic
98 116564 RK	PRD-9,600	Residential 9,600 sq. ft.	SFR-Basic
98 109010 RK	PRD-9,600	Residential 9,600 sq. ft.	Single Family Res-Combo
98 116565 RK	PRD-9,600	Residential 9,600 sq. ft.	SFR-Basic

Accessory Dwelling Units

Index # - File Name: 1.0022 - Single Family Dwellings Data\_Snohomish County.pdf

98 109621 MH	R-5	Rural-5 Acre	MH Park-Double Wide
98 109776 RK	R-5	Rural-5 Acre	Single Family Res-Combo
98 109756 RK	CITY	City	SFR-Basic
98 109965 MH	R-5	Rural-5 Acre	Triple Wide
98 109851 MH	RRT-10	Rural Resource Transition-10	Double Wide
98 109134 RK	PRD-7,200	Residential 7,200 sq. ft.	Single Family Res-Combo
98 110645 RK	PRD-7,200	Residential 7,200 sq. ft.	Single Family Res-Combo
98 109524 RK	PRD-7,200	Residential 7,200 sq. ft.	Single Family Res-Combo
98 109526 RK	PRD-7,200	Residential 7,200 sq. ft.	Single Family Res-Combo
98 116268 RK	PRD-7,200	Residential 7,200 sq. ft.	SFR-Basic
98 116265 RK	PRD-7,200	Residential 7,200 sq. ft.	SFR-Basic
98 110055 RK	R-5	Rural-5 Acre	Single Family Res-Combo
98 108320 RK	CITY	City	Single Family Res-Combo
98 116357 RK	CITY	City	Single Family Res-Combo
98 110290 RK	CITY	City	SFR-Basic
98 103262 RK	CITY	City	Single Family Res-Combo
98 110505 RK	CITY	City	SFR-Basic
98 116449 RK	CITY	City	Single Family Res-Combo
98 110084 RK	CITY	City	SFR-Basic
98 110291 RK	CITY	City	SFR-Basic
98 110085 RK	CITY	City	SFR-Basic
98 110292 RK	CITY	City	SFR-Basic
98 108319 RK	CITY	City	Single Family Res-Combo
98 150516 RK	CITY	City	SFR-Basic
98 110506 RK	CITY	City	SFR-Basic
98 116138 RK	CITY	City	Single Family Res-Combo
98 110282 RK	R-5	Rural-5 Acre	Single Family Res-Combo
98 150474 RK	PRD-7,200	Residential 7,200 sq. ft.	SFR-Basic
98 109653 RK	PRD-LDMR	Low Density Multiple Reside	Single Family Res-Combo
98 108841 RK	PRD-LDMR	Low Density Multiple Reside	Single Family Res-Combo
98 110148 RK	PRD-LDMR	Low Density Multiple Reside	SFR-Basic
98 110149 RK	PRD-LDMR	Low Density Multiple Reside	SFR-Basic
98 108845 RK	PRD-LDMR	Low Density Multiple Reside	Single Family Res-Combo
98 108843 RK	PRD-LDMR	Low Density Multiple Reside	Single Family Res-Combo
98 110154 RK	PRD-LDMR	Low Density Multiple Reside	SFR-Basic
98 110155 RK	PRD-LDMR	Low Density Multiple Reside	SFR-Basic
98 110159 RK	PRD-LDMR	Low Density Multiple Reside	SFR-Basic
98 110160 RK	PRD-LDMR	Low Density Multiple Reside	SFR-Basic
98 110171 RK	R-5	Rural-5 Acre	Single Family Res-Combo
98 104422 RK	CITY	City	Duplex-Combo
98 100372 RK	R-5	Rural-5 Acre	Single Family Res-Combo
97 111602 RK	R-5	Rural-5 Acre	Single Family Res-Combo
98 101438 MH	R-5	Rural-5 Acre	Double Wide
98 101431 MH	R-5	Rural-5 Acre	Double Wide
98 101111 MH	R-5	Rural-5 Acre	Double Wide
98 100065 MH	R-5	Rural-5 Acre	Double Wide
98 100066 MH	R-5	Rural-5 Acre	Double Wide

Accessory Dwelling Units

Index # - File Name: 1.0022 - Single Family Dwellings Data\_Snohomish County.pdf

97 111651 RK	R-5	Rural-5 Acre	Single Family Res-Combo
98 100592 RK	R-5	Rural-5 Acre	Single Family Res-Combo
98 105666 RK	R-9,600	Residential 9,600 sq. ft.	SFR-Basic
98 109233 RK	R-9,600	Residential 9,600 sq. ft.	Single Family Res-Combo
98 105668 RK	R-9,600	Residential 9,600 sq. ft.	SFR-Basic
98 102071 RK	R-9,600	Residential 9,600 sq. ft.	Single Family Res-Combo
98 105670 RK	R-9,600	Residential 9,600 sq. ft.	SFR-Basic
98 105057 RK	R-9,600	Residential 9,600 sq. ft.	SFR-Basic
98 100538 RK	R-9,600	Residential 9,600 sq. ft.	Single Family Res-Combo
98 109235 RK	R-9,600	Residential 9,600 sq. ft.	Single Family Res-Combo
98 100541 RK	R-9,600	Residential 9,600 sq. ft.	Single Family Res-Combo
98 101883 RK	R-9,600	Residential 9,600 sq. ft.	SFR-Basic
98 100419 RK	R-9,600	Residential 9,600 sq. ft.	SFR-Basic
98 105664 RK	R-9,600	Residential 9,600 sq. ft.	SFR-Basic
98 105669 RK	R-9,600	Residential 9,600 sq. ft.	SFR-Basic
98 105055 RK	R-9,600	Residential 9,600 sq. ft.	SFR-Basic
98 100539 RK	R-9,600	Residential 9,600 sq. ft.	Single Family Res-Combo
98 104294 RK	F	Forestry	Single Family Res-Combo
98 101822 RK	R-9,600	Residential 9,600 sq. ft.	Single Family Res-Combo
98 100455 RK	R-9,600	Residential 9,600 sq. ft.	SFR-Basic
98 100243 RK	R-9,600	Residential 9,600 sq. ft.	SFR-Basic
98 102372 RK	R-9,600	Residential 9,600 sq. ft.	Single Family Res-Combo
98 101037 RK	R-9,600	Residential 9,600 sq. ft.	SFR-Basic
98 100852 RK	R-9,600	Residential 9,600 sq. ft.	Single Family Res-Combo
97 111947 RK	R-9,600	Residential 9,600 sq. ft.	Single Family Res-Combo
98 102265 RK	R-9,600	Residential 9,600 sq. ft.	SFR-Basic
98 100851 RK	R-9,600	Residential 9,600 sq. ft.	SFR-Basic
98 101005 RK	R-9,600	Residential 9,600 sq. ft.	Single Family Res-Combo
98 100453 RK	R-9,600	Residential 9,600 sq. ft.	SFR-Basic
98 102076 RK	R-9,600	Residential 9,600 sq. ft.	SFR-Basic
98 102078 RK	R-9,600	Residential 9,600 sq. ft.	SFR-Basic
98 100241 RK	R-9,600	Residential 9,600 sq. ft.	SFR-Basic
98 101622 RK	R-9,600	Residential 9,600 sq. ft.	SFR-Basic
98 104118 RK	R-9,600	Residential 9,600 sq. ft.	SFR-Basic
98 100240 RK	R-9,600	Residential 9,600 sq. ft.	SFR-Basic
98 100884 RK	R-9,600	Residential 9,600 sq. ft.	SFR-Basic
98 100620 RK	R-9,600	Residential 9,600 sq. ft.	SFR-Basic
98 102261 RK	R-9,600	Residential 9,600 sq. ft.	SFR-Basic
98 106229 RK	R-9,600	Residential 9,600 sq. ft.	SFR-Basic
98 103099 RK	R-9,600	Residential 9,600 sq. ft.	SFR-Basic
98 103478 RK	R-9,600	Residential 9,600 sq. ft.	SFR-Basic
98 103474 RK	R-9,600	Residential 9,600 sq. ft.	SFR-Basic
98 102260 RK	R-9,600	Residential 9,600 sq. ft.	SFR-Basic
98 100619 RK	R-9,600	Residential 9,600 sq. ft.	SFR-Basic
98 103090 RK	R-9,600	Residential 9,600 sq. ft.	SFR-Basic
97 111532 RK	R-9,600	Residential 9,600 sq. ft.	SFR-Basic
98 101823 RK	R-9,600	Residential 9,600 sq. ft.	SFR-Basic



Accessory Dwelling Units

Index # - File Name: 1.0022 - Single Family Dwellings Data\_Snohomish County.pdf

98 103572 RK	R-9,600	Residential 9,600 sq. ft.	SFR-Basic
98 102614 RK	R-9,600	Residential 9,600 sq. ft.	SFR-Basic
98 100885 RK	R-9,600	Residential 9,600 sq. ft.	SFR-Basic
98 101203 RK	R-9,600	Residential 9,600 sq. ft.	SFR-Basic
98 104117 RK	R-9,600	Residential 9,600 sq. ft.	SFR-Basic
98 100886 RK	R-9,600	Residential 9,600 sq. ft.	Single Family Res-Combo
98 100238 RK	R-9,600	Residential 9,600 sq. ft.	SFR-Basic
98 104975 RK	R-9,600	Residential 9,600 sq. ft.	Single Family Res-Combo
98 103571 RK	R-9,600	Residential 9,600 sq. ft.	SFR-Basic
98 101824 RK	R-9,600	Residential 9,600 sq. ft.	SFR-Basic
98 101711 RK	R-9,600	Residential 9,600 sq. ft.	SFR-Basic
98 103575 RK	R-9,600	Residential 9,600 sq. ft.	Single Family Res-Combo
98 103472 RK	R-9,600	Residential 9,600 sq. ft.	SFR-Basic
98 106040 RK	R-9,600	Residential 9,600 sq. ft.	SFR-Basic
98 102667 RK	R-9,600	Residential 9,600 sq. ft.	Single Family Res-Combo
98 100581 RK	R-9,600	Residential 9,600 sq. ft.	SFR-Basic
98 104115 RK	R-9,600	Residential 9,600 sq. ft.	Single Family Res-Combo
98 100579 RK	R-9,600	Residential 9,600 sq. ft.	SFR-Basic
98 102615 RK	R-9,600	Residential 9,600 sq. ft.	SFR-Basic
98 102671 RK	R-9,600	Residential 9,600 sq. ft.	Single Family Res-Combo
98 106777 RK	R-9,600	Residential 9,600 sq. ft.	Single Family Res-Combo
98 101619 RK	R-9,600	Residential 9,600 sq. ft.	SFR-Basic
97 111533 RK	R-9,600	Residential 9,600 sq. ft.	SFR-Basic
98 104843 RK	R-9,600	Residential 9,600 sq. ft.	SFR-Basic
98 102263 RK	R-9,600	Residential 9,600 sq. ft.	Single Family Res-Combo
98 101217 RK	R-9,600	Residential 9,600 sq. ft.	SFR-Basic
97 111356 MH	R-5	Rural-5 Acre	Triple Wide
98 104613 RK	PRD-9,600	Residential 9,600 sq. ft.	SFR-Basic
98 104614 RK	PRD-9,600	Residential 9,600 sq. ft.	SFR-Basic
98 104806 RK	PRD-9,600	Residential 9,600 sq. ft.	SFR-Basic
98 102678 RK	R-5	Rural-5 Acre	Single Family Res-Combo
98 109043 RK	R-5	Rural-5 Acre	Single Family Res-Combo
98 102680 RK	R-5	Rural-5 Acre	Single Family Res-Combo
98 107204 RK	R-5	Rural-5 Acre	Single Family Res-Combo
98 108534 RK	R-5	Rural-5 Acre	Single Family Res-Combo
98 106973 RK	R-5	Rural-5 Acre	Single Family Res-Combo
98 100492 RK	R-5	Rural-5 Acre	Single Family Res-Combo
98 104248 RK	R-5	Rural-5 Acre	Single Family Res-Combo
98 100490 RK	R-5	Rural-5 Acre	Single Family Res-Combo
97 111022 RK	R-5	Rural-5 Acre	Single Family Res-Combo
98 105941 RK	PRD-9,600	Residential 9,600 sq. ft.	SFR-Basic
98 105943 RK	PRD-9,600	Residential 9,600 sq. ft.	SFR-Basic
97 110273 RK	R-5	Rural-5 Acre	Single Family Res-Combo
98 109177 RK	R-5	Rural-5 Acre	Single Family Res-Combo
98 106083 RK	R-5	Rural-5 Acre	Single Family Res-Combo
98 106212 RK	R-5	Rural-5 Acre	Single Family Res-Combo
98 101986 RK	R-5	Rural-5 Acre	Single Family Res-Combo

Accessory Dwelling Units

Index # - File Name: 1.0022 - Single Family Dwellings Data\_Snohomish County.pdf

97 110834 RK	R-5	Rural-5 Acre	Single Family Res-Combo
98 102272 RK	R-5	Rural-5 Acre	Single Family Res-Combo
98 104808 RK	R-5	Rural-5 Acre	Single Family Res-Combo
98 109176 RK	R-5	Rural-5 Acre	Single Family Res-Combo
98 106084 RK	R-5	Rural-5 Acre	Single Family Res-Combo
98 108538 RK	R-5	Rural-5 Acre	Single Family Res-Combo
98 106087 RK	R-5	Rural-5 Acre	Single Family Res-Combo
98 102936 RK	R-9,600	Residential 9,600 sq. ft.	Single Family Res-Combo
97 111098 RK	R-8,400	Residential 8,400 sq. ft.	Duplex-Combo
98 101575 RK	R-9,600	Residential 9,600 sq. ft.	SFR-Basic
98 103447 RK	R-9,600	Residential 9,600 sq. ft.	Single Family Res-Combo
98 101574 RK	R-9,600	Residential 9,600 sq. ft.	Single Family Res-Combo
98 102235 RK	R-5	Rural-5 Acre	SFR-Basic
97 111486 MH	CITY	City	Double Wide
98 100583 RK	R-5	Rural-5 Acre	Single Family Res-Combo
98 100582 RK	R-5	Rural-5 Acre	Single Family Res-Combo
98 103992 RK	R-5	Rural-5 Acre	Single Family Res-Combo
98 109094 RK	R-5	Rural-5 Acre	Single Family Res-Combo
98 100176 RK	R-5	Rural-5 Acre	Single Family Res-Combo
97 110977 MH	F	Forestry	Double Wide
98 103750 MH	R-5	Rural-5 Acre	Triple Wide
98 109280 RK	R-5	Rural-5 Acre	Single Family Res-Combo
97 110970 RK	R-5	Rural-5 Acre	SFR-Basic
97 108512 RK	R-5	Rural-5 Acre	Single Family Res-Combo
97 110718 RK	R-5	Rural-5 Acre	Single Family Res-Combo
98 100330 RK	R-5	Rural-5 Acre	Single Family Res-Combo
98 103130 RK	R-5	Rural-5 Acre	Single Family Res-Combo
98 110336 MH	R-5	Rural-5 Acre	Triple Wide
98 101145 RK	R-5	Rural-5 Acre	Single Family Res-Combo
98 105936 RK	PRD-9,600	Residential 9,600 sq. ft.	SFR-Basic
98 105939 RK	PRD-9,600	Residential 9,600 sq. ft.	SFR-Basic
98 105937 RK	PRD-9,600	Residential 9,600 sq. ft.	SFR-Basic
98 103743 RK	PRD-9,600	Residential 9,600 sq. ft.	SFR-Basic
98 103744 RK	PRD-9,600	Residential 9,600 sq. ft.	SFR-Basic
98 103745 RK	PRD-9,600	Residential 9,600 sq. ft.	SFR-Basic
98 104028 RK	PRD-9,600	Residential 9,600 sq. ft.	SFR-Basic
98 104029 RK	PRD-9,600	Residential 9,600 sq. ft.	SFR-Basic
98 104030 RK	PRD-9,600	Residential 9,600 sq. ft.	SFR-Basic
98 104031 RK	PRD-9,600	Residential 9,600 sq. ft.	SFR-Basic
98 104032 RK	PRD-9,600	Residential 9,600 sq. ft.	SFR-Basic
98 104273 RK	PRD-9,600	Residential 9,600 sq. ft.	SFR-Basic
98 104274 RK	PRD-9,600	Residential 9,600 sq. ft.	SFR-Basic
98 104803 RK	PRD-9,600	Residential 9,600 sq. ft.	SFR-Basic
98 104802 RK	PRD-9,600	Residential 9,600 sq. ft.	SFR-Basic
98 104804 RK	PRD-9,600	Residential 9,600 sq. ft.	SFR-Basic
98 105032 RK	PRD-9,600	Residential 9,600 sq. ft.	SFR-Basic
98 105033 RK	PRD-9,600	Residential 9,600 sq. ft.	SFR-Basic

Accessory Dwelling Units

Index # - File Name: 1.0022 - Single Family Dwellings Data\_Snohomish County.pdf

98 105034 RK	PRD-9,600	Residential 9,600 sq. ft.	SFR-Basic
98 105035 RK	PRD-9,600	Residential 9,600 sq. ft.	SFR-Basic
98 105036 RK	PRD-9,600	Residential 9,600 sq. ft.	SFR-Basic
98 105409 RK	PRD-9,600	Residential 9,600 sq. ft.	SFR-Basic
98 105411 RK	PRD-9,600	Residential 9,600 sq. ft.	SFR-Basic
98 105412 RK	PRD-9,600	Residential 9,600 sq. ft.	SFR-Basic
98 105413 RK	PRD-9,600	Residential 9,600 sq. ft.	SFR-Basic
98 105414 RK	PRD-9,600	Residential 9,600 sq. ft.	SFR-Basic
98 105633 RK	PRD-9,600	Residential 9,600 sq. ft.	SFR-Basic
98 101610 RK	PRD-9,600	Residential 9,600 sq. ft.	SFR-Basic
98 101614 RK	PRD-9,600	Residential 9,600 sq. ft.	SFR-Basic
98 101519 RK	PRD-9,600	Residential 9,600 sq. ft.	SFR-Basic
98 101520 RK	PRD-9,600	Residential 9,600 sq. ft.	SFR-Basic
98 101611 RK	PRD-9,600	Residential 9,600 sq. ft.	SFR-Basic
98 101521 RK	PRD-9,600	Residential 9,600 sq. ft.	SFR-Basic
98 101522 RK	PRD-9,600	Residential 9,600 sq. ft.	SFR-Basic
98 101518 RK	PRD-9,600	Residential 9,600 sq. ft.	SFR-Basic
98 101523 RK	PRD-9,600	Residential 9,600 sq. ft.	SFR-Basic
98 101517 RK	PRD-9,600	Residential 9,600 sq. ft.	SFR-Basic
98 101196 RK	PRD-9,600	Residential 9,600 sq. ft.	SFR-Basic
98 101193 RK	PRD-9,600	Residential 9,600 sq. ft.	SFR-Basic
98 101194 RK	PRD-9,600	Residential 9,600 sq. ft.	SFR-Basic
98 101198 RK	PRD-9,600	Residential 9,600 sq. ft.	SFR-Basic
98 101620 RK	PRD-9,600	Residential 9,600 sq. ft.	SFR-Basic
98 101192 RK	PRD-9,600	Residential 9,600 sq. ft.	SFR-Basic
98 101191 RK	PRD-9,600	Residential 9,600 sq. ft.	SFR-Basic
98 101199 RK	PRD-9,600	Residential 9,600 sq. ft.	SFR-Basic
98 101195 RK	PRD-9,600	Residential 9,600 sq. ft.	SFR-Basic
98 101190 RK	PRD-9,600	Residential 9,600 sq. ft.	SFR-Basic
98 101197 RK	PRD-9,600	Residential 9,600 sq. ft.	SFR-Basic
98 101616 RK	PRD-9,600	Residential 9,600 sq. ft.	SFR-Basic
98 101474 RK	PRD-9,600	Residential 9,600 sq. ft.	SFR-Basic
98 104023 RK	PRD-9,600	Residential 9,600 sq. ft.	SFR-Basic
98 104024 RK	PRD-9,600	Residential 9,600 sq. ft.	SFR-Basic
98 104267 RK	PRD-9,600	Residential 9,600 sq. ft.	SFR-Basic
98 104268 RK	PRD-9,600	Residential 9,600 sq. ft.	SFR-Basic
98 104270 RK	PRD-9,600	Residential 9,600 sq. ft.	SFR-Basic
98 104272 RK	PRD-9,600	Residential 9,600 sq. ft.	SFR-Basic
98 104616 RK	PRD-9,600	Residential 9,600 sq. ft.	SFR-Basic
98 104615 RK	PRD-9,600	Residential 9,600 sq. ft.	SFR-Basic
98 104617 RK	PRD-9,600	Residential 9,600 sq. ft.	SFR-Basic
98 103740 RK	PRD-9,600	Residential 9,600 sq. ft.	SFR-Basic
98 103741 RK	PRD-9,600	Residential 9,600 sq. ft.	SFR-Basic
98 103742 RK	PRD-9,600	Residential 9,600 sq. ft.	SFR-Basic
98 104025 RK	PRD-9,600	Residential 9,600 sq. ft.	SFR-Basic
98 104026 RK	PRD-9,600	Residential 9,600 sq. ft.	SFR-Basic
98 104027 RK	PRD-9,600	Residential 9,600 sq. ft.	SFR-Basic

Accessory Dwelling Units

Index # - File Name: 1.0022 - Single Family Dwellings Data\_Snohomish County.pdf

98 102556 RK	PRD-9,600	Residential 9,600 sq. ft.	SFR-Basic
98 101475 RK	PRD-9,600	Residential 9,600 sq. ft.	SFR-Basic
98 101476 RK	PRD-9,600	Residential 9,600 sq. ft.	SFR-Basic
98 101483 RK	PRD-9,600	Residential 9,600 sq. ft.	SFR-Basic
98 101484 RK	PRD-9,600	Residential 9,600 sq. ft.	SFR-Basic
98 101478 RK	PRD-9,600	Residential 9,600 sq. ft.	SFR-Basic
98 101479 RK	PRD-9,600	Residential 9,600 sq. ft.	SFR-Basic
98 101485 RK	PRD-9,600	Residential 9,600 sq. ft.	SFR-Basic
98 101486 RK	PRD-9,600	Residential 9,600 sq. ft.	SFR-Basic
98 101480 RK	PRD-9,600	Residential 9,600 sq. ft.	SFR-Basic
98 101481 RK	PRD-9,600	Residential 9,600 sq. ft.	SFR-Basic
98 101487 RK	PRD-9,600	Residential 9,600 sq. ft.	SFR-Basic
98 101501 RK	PRD-9,600	Residential 9,600 sq. ft.	SFR-Basic
98 101491 RK	PRD-9,600	Residential 9,600 sq. ft.	SFR-Basic
98 101488 RK	PRD-9,600	Residential 9,600 sq. ft.	SFR-Basic
98 101492 RK	PRD-9,600	Residential 9,600 sq. ft.	SFR-Basic
98 101502 RK	PRD-9,600	Residential 9,600 sq. ft.	SFR-Basic
98 101617 RK	PRD-9,600	Residential 9,600 sq. ft.	SFR-Basic
98 101493 RK	PRD-9,600	Residential 9,600 sq. ft.	SFR-Basic
98 101503 RK	PRD-9,600	Residential 9,600 sq. ft.	SFR-Basic
98 101618 RK	PRD-9,600	Residential 9,600 sq. ft.	SFR-Basic
98 101494 RK	PRD-9,600	Residential 9,600 sq. ft.	SFR-Basic
98 101495 RK	PRD-9,600	Residential 9,600 sq. ft.	SFR-Basic
98 103735 RK	PRD-9,600	Residential 9,600 sq. ft.	SFR-Basic
98 103737 RK	PRD-9,600	Residential 9,600 sq. ft.	SFR-Basic
98 103739 RK	PRD-9,600	Residential 9,600 sq. ft.	SFR-Basic
98 103738 RK	PRD-9,600	Residential 9,600 sq. ft.	SFR-Basic
98 104017 RK	PRD-9,600	Residential 9,600 sq. ft.	SFR-Basic
98 104018 RK	PRD-9,600	Residential 9,600 sq. ft.	SFR-Basic
98 104019 RK	PRD-9,600	Residential 9,600 sq. ft.	SFR-Basic
98 106549 RK	PRD-9,600	Residential 9,600 sq. ft.	SFR-Basic
98 104020 RK	PRD-9,600	Residential 9,600 sq. ft.	SFR-Basic
98 104262 RK	PRD-9,600	Residential 9,600 sq. ft.	SFR-Basic
98 104263 RK	PRD-9,600	Residential 9,600 sq. ft.	SFR-Basic
98 104264 RK	PRD-9,600	Residential 9,600 sq. ft.	SFR-Basic
98 104265 RK	PRD-9,600	Residential 9,600 sq. ft.	SFR-Basic
98 104266 RK	PRD-9,600	Residential 9,600 sq. ft.	SFR-Basic
98 104622 RK	PRD-9,600	Residential 9,600 sq. ft.	SFR-Basic
98 104623 RK	PRD-9,600	Residential 9,600 sq. ft.	SFR-Basic
98 101504 RK	PRD-9,600	Residential 9,600 sq. ft.	SFR-Basic
98 101489 RK	PRD-9,600	Residential 9,600 sq. ft.	SFR-Basic
98 104625 RK	PRD-9,600	Residential 9,600 sq. ft.	SFR-Basic
98 104626 RK	PRD-9,600	Residential 9,600 sq. ft.	SFR-Basic
98 104627 RK	PRD-9,600	Residential 9,600 sq. ft.	SFR-Basic
98 104791 RK	PRD-9,600	Residential 9,600 sq. ft.	SFR-Basic
98 104793 RK	PRD-9,600	Residential 9,600 sq. ft.	SFR-Basic
98 104794 RK	PRD-9,600	Residential 9,600 sq. ft.	SFR-Basic

Accessory Dwelling Units

Index # - File Name: 1.0022 - Single Family Dwellings Data\_Snohomish County.pdf

98 104795 RK	PRD-9,600	Residential 9,600 sq. ft.	SFR-Basic
98 104796 RK	PRD-9,600	Residential 9,600 sq. ft.	SFR-Basic
98 101505 RK	PRD-9,600	Residential 9,600 sq. ft.	SFR-Basic
98 101506 RK	PRD-9,600	Residential 9,600 sq. ft.	SFR-Basic
98 101497 RK	PRD-9,600	Residential 9,600 sq. ft.	SFR-Basic
98 101498 RK	PRD-9,600	Residential 9,600 sq. ft.	SFR-Basic
98 101507 RK	PRD-9,600	Residential 9,600 sq. ft.	SFR-Basic
98 101490 RK	PRD-9,600	Residential 9,600 sq. ft.	SFR-Basic
98 101499 RK	PRD-9,600	Residential 9,600 sq. ft.	SFR-Basic
98 105037 RK	PRD-9,600	Residential 9,600 sq. ft.	SFR-Basic
98 105038 RK	PRD-9,600	Residential 9,600 sq. ft.	SFR-Basic
98 105039 RK	PRD-9,600	Residential 9,600 sq. ft.	SFR-Basic
98 105041 RK	PRD-9,600	Residential 9,600 sq. ft.	SFR-Basic
98 105042 RK	PRD-9,600	Residential 9,600 sq. ft.	SFR-Basic
98 105398 RK	PRD-9,600	Residential 9,600 sq. ft.	SFR-Basic
98 105399 RK	PRD-9,600	Residential 9,600 sq. ft.	SFR-Basic
98 105401 RK	PRD-9,600	Residential 9,600 sq. ft.	SFR-Basic
98 105402 RK	PRD-9,600	Residential 9,600 sq. ft.	SFR-Basic
98 105403 RK	PRD-9,600	Residential 9,600 sq. ft.	SFR-Basic
98 105404 RK	PRD-9,600	Residential 9,600 sq. ft.	SFR-Basic
98 105634 RK	PRD-9,600	Residential 9,600 sq. ft.	SFR-Basic
98 105635 RK	PRD-9,600	Residential 9,600 sq. ft.	SFR-Basic
98 105636 RK	PRD-9,600	Residential 9,600 sq. ft.	SFR-Basic
98 105637 RK	PRD-9,600	Residential 9,600 sq. ft.	SFR-Basic
98 105638 RK	PRD-9,600	Residential 9,600 sq. ft.	SFR-Basic
98 105639 RK	PRD-9,600	Residential 9,600 sq. ft.	SFR-Basic
98 105640 RK	PRD-9,600	Residential 9,600 sq. ft.	SFR-Basic
98 105641 RK	PRD-9,600	Residential 9,600 sq. ft.	SFR-Basic
98 105642 RK	PRD-9,600	Residential 9,600 sq. ft.	SFR-Basic
98 104797 RK	PRD-9,600	Residential 9,600 sq. ft.	SFR-Basic
98 104792 RK	PRD-9,600	Residential 9,600 sq. ft.	SFR-Basic
98 104799 RK	PRD-9,600	Residential 9,600 sq. ft.	SFR-Basic
98 104800 RK	PRD-9,600	Residential 9,600 sq. ft.	SFR-Basic
98 105043 RK	PRD-9,600	Residential 9,600 sq. ft.	SFR-Basic
98 105044 RK	PRD-9,600	Residential 9,600 sq. ft.	SFR-Basic
98 105046 RK	PRD-9,600	Residential 9,600 sq. ft.	SFR-Basic
98 105047 RK	PRD-9,600	Residential 9,600 sq. ft.	SFR-Basic
98 105048 RK	PRD-9,600	Residential 9,600 sq. ft.	SFR-Basic
98 105405 RK	PRD-9,600	Residential 9,600 sq. ft.	SFR-Basic
98 105406 RK	PRD-9,600	Residential 9,600 sq. ft.	SFR-Basic
98 105407 RK	PRD-9,600	Residential 9,600 sq. ft.	SFR-Basic
98 105408 RK	PRD-9,600	Residential 9,600 sq. ft.	SFR-Basic
98 105643 RK	PRD-9,600	Residential 9,600 sq. ft.	SFR-Basic
98 106517 RK	R-5	Rural-5 Acre	Single Family Res-Combo
98 104489 RK	R-9,600	Residential 9,600 sq. ft.	SFR-Basic
98 103673 RK	R-9,600	Residential 9,600 sq. ft.	SFR-Basic
98 104484 RK	R-9,600	Residential 9,600 sq. ft.	SFR-Basic

Accessory Dwelling Units

Index # - File Name: 1.0022 - Single Family Dwellings Data\_Snohomish County.pdf

98 103270 RK	R-9,600	Residential 9,600 sq. ft.	SFR-Basic
98 104483 RK	R-9,600	Residential 9,600 sq. ft.	SFR-Basic
98 102353 RK	R-5	Rural-5 Acre	SFR-Basic
98 102361 RK	R-5	Rural-5 Acre	SFR-Basic
98 102448 RK	R-5	Rural-5 Acre	SFR-Basic
98 103420 MH	HI	Heavy Industrial	Double Wide
98 102457 RK	R-5	Rural-5 Acre	Single Family Res-Combo
98 100483 RK	R-5	Rural-5 Acre	Single Family Res-Combo
98 102234 RK	R-5	Rural-5 Acre	SFR-Basic
98 102398 RK	R-5	Rural-5 Acre	SFR-Basic
98 105925 RK	R-5	Rural-5 Acre	SFR-Basic
98 105927 RK	R-5	Rural-5 Acre	SFR-Basic
98 106814 RK	R-5	Rural-5 Acre	Single Family Res-Combo
98 110586 RK	R-5	Rural-5 Acre	Single Family Res-Combo
98 110590 RK	R-5	Rural-5 Acre	SFR-Basic
98 102237 RK	R-5	Rural-5 Acre	SFR-Basic
98 102236 RK	R-5	Rural-5 Acre	SFR-Basic
98 103002 RK	R-5	Rural-5 Acre	Single Family Res-Combo
98 102416 RK	R-5	Rural-5 Acre	Single Family Res-Combo
98 103662 RK	CITY	City	SFR-Basic
98 103998 RK	CITY	City	SFR-Basic
98 103661 RK	CITY	City	SFR-Basic
98 102659 RK	CITY	City	SFR-Basic
98 103660 RK	CITY	City	SFR-Basic
98 106145 RK	CITY	City	SFR-Basic
98 106243 RK	CITY	City	SFR-Basic
98 106253 RK	CITY	City	SFR-Basic
98 106146 RK	CITY	City	SFR-Basic
98 106147 RK	CITY	City	SFR-Basic
98 104472 RK	CITY	City	SFR-Basic
98 102959 RK	CITY	City	SFR-Basic
98 105557 RK	CITY	City	SFR-Basic
98 106249 RK	CITY	City	SFR-Basic
98 103663 RK	CITY	City	SFR-Basic
98 102430 RK	CITY	City	SFR-Basic
98 106241 RK	CITY	City	SFR-Basic
98 106250 RK	CITY	City	SFR-Basic
98 106240 RK	CITY	City	SFR-Basic
98 102960 RK	CITY	City	SFR-Basic
98 106247 RK	CITY	City	SFR-Basic
98 106555 RK	CITY	City	SFR-Basic
98 106251 RK	CITY	City	SFR-Basic
98 102433 RK	CITY	City	SFR-Basic
98 102431 RK	CITY	City	SFR-Basic
98 102435 RK	CITY	City	SFR-Basic
98 102858 RK	CITY	City	SFR-Basic
98 102859 RK	CITY	City	SFR-Basic

Accessory Dwelling Units

Index # - File Name: 1.0022 - Single Family Dwellings Data\_Snohomish County.pdf

98 102434 RK	CITY	City	SFR-Basic
98 102860 RK	CITY	City	SFR-Basic
98 102436 RK	CITY	City	SFR-Basic
98 106239 RK	CITY	City	SFR-Basic
98 106246 RK	CITY	City	SFR-Basic
98 106252 RK	CITY	City	SFR-Basic
98 105331 RK	CITY	City	SFR-Basic
98 105330 RK	CITY	City	SFR-Basic
98 105332 RK	CITY	City	SFR-Basic
98 104241 RK	CITY	City	SFR-Basic
98 104243 RK	CITY	City	SFR-Basic
98 103999 RK	CITY	City	SFR-Basic
98 105556 RK	CITY	City	SFR-Basic
98 104469 RK	CITY	City	Single Family Res-Combo
98 105333 RK	CITY	City	SFR-Basic
98 106148 RK	CITY	City	SFR-Basic
98 106255 RK	CITY	City	SFR-Basic
98 104244 RK	CITY	City	SFR-Basic
98 104474 RK	CITY	City	SFR-Basic
98 104471 RK	CITY	City	SFR-Basic
98 104242 RK	CITY	City	SFR-Basic
98 102656 RK	CITY	City	SFR-Basic
98 102658 RK	CITY	City	SFR-Basic
98 106254 RK	CITY	City	SFR-Basic
98 106245 RK	CITY	City	SFR-Basic
98 102358 RK	R-5	Rural-5 Acre	SFR-Basic
98 102004 MH	R-5	Rural-5 Acre	Double Wide
98 102618 RK	CITY	City	SFR-Basic
98 102624 RK	CITY	City	SFR-Basic
98 102413 RK	CITY	City	SFR-Basic
98 102623 RK	CITY	City	SFR-Basic
98 102619 RK	CITY	City	SFR-Basic
98 102415 RK	CITY	City	SFR-Basic
98 102622 RK	CITY	City	SFR-Basic
98 104357 RK	CITY	City	SFR-Basic
98 104360 RK	CITY	City	SFR-Basic
98 104565 RK	CITY	City	SFR-Basic
98 104571 RK	CITY	City	SFR-Basic
98 104560 RK	CITY	City	SFR-Basic
98 104573 RK	CITY	City	SFR-Basic
98 104562 RK	CITY	City	SFR-Basic
98 104564 RK	CITY	City	SFR-Basic
98 104568 RK	CITY	City	SFR-Basic
98 104572 RK	CITY	City	SFR-Basic
98 104559 RK	CITY	City	SFR-Basic
98 104557 RK	CITY	City	SFR-Basic
98 104361 RK	CITY	City	SFR-Basic

Accessory Dwelling Units

Index # - File Name: 1.0022 - Single Family Dwellings Data\_Snohomish County.pdf

98 104359 RK	CITY	City	SFR-Basic
98 102620 RK	CITY	City	SFR-Basic
98 102056 RK	CITY	City	SFR-Basic
98 102621 RK	CITY	City	SFR-Basic
98 100964 RK	CITY	City	Single Family Res-Combo
98 100965 RK	CITY	City	Single Family Res-Combo
98 101147 RK	CITY	City	Single Family Res-Combo
98 102716 MH	R-5	Rural-5 Acre	Double Wide
98 101778 RK	R-7,200	Residential 7,200 sq. ft.	Single Family Res-Combo
98 101776 RK	R-7,200	Residential 7,200 sq. ft.	Single Family Res-Combo
98 102161 RK	R-5	Rural-5 Acre	Duplex-Combo
98 101987 RK	R-5	Rural-5 Acre	Single Family Res-Combo
98 101815 RK	R-5	Rural-5 Acre	Single Family Res-Combo
98 108815 RK	R-5	Rural-5 Acre	Single Family Res-Combo
98 102049 RK	RD	Rural Diversification	Single Family Res-Combo
98 104114 RK	R-5	Rural-5 Acre	Single Family Res-Combo
98 102125 RK	F	Forestry	Single Family Res-Combo
98 102311 RK	R-9,600	Residential 9,600 sq. ft.	SFR-Basic
98 103585 RK	R-9,600	Residential 9,600 sq. ft.	SFR-Basic
98 102312 RK	R-9,600	Residential 9,600 sq. ft.	SFR-Basic
98 102310 RK	R-9,600	Residential 9,600 sq. ft.	SFR-Basic
98 102308 RK	R-9,600	Residential 9,600 sq. ft.	SFR-Basic
98 102306 RK	R-9,600	Residential 9,600 sq. ft.	SFR-Basic
98 103271 RK	R-9,600	Residential 9,600 sq. ft.	SFR-Basic
98 103675 RK	R-9,600	Residential 9,600 sq. ft.	SFR-Basic
97 109442 RK	R-9,600	Residential 9,600 sq. ft.	Single Family Res-Combo
98 103676 RK	R-9,600	Residential 9,600 sq. ft.	SFR-Basic
98 103272 RK	R-9,600	Residential 9,600 sq. ft.	SFR-Basic
98 105735 RK	R-9,600	Residential 9,600 sq. ft.	Single Family Res-Combo
98 106190 RK	R-9,600	Residential 9,600 sq. ft.	SFR-Basic
98 106191 RK	R-9,600	Residential 9,600 sq. ft.	SFR-Basic
98 106192 RK	R-9,600	Residential 9,600 sq. ft.	SFR-Basic
98 106193 RK	R-9,600	Residential 9,600 sq. ft.	SFR-Basic
98 106194 RK	R-9,600	Residential 9,600 sq. ft.	SFR-Basic
98 106189 RK	R-9,600	Residential 9,600 sq. ft.	SFR-Basic
98 105736 RK	R-9,600	Residential 9,600 sq. ft.	Single Family Res-Combo
98 108596 RK	R-9,600	Residential 9,600 sq. ft.	SFR-Basic
98 108592 RK	R-9,600	Residential 9,600 sq. ft.	SFR-Basic
98 109336 RK	R-9,600	Residential 9,600 sq. ft.	SFR-Basic
98 109329 RK	R-9,600	Residential 9,600 sq. ft.	SFR-Basic
98 109327 RK	R-9,600	Residential 9,600 sq. ft.	SFR-Basic
98 109332 RK	R-9,600	Residential 9,600 sq. ft.	SFR-Basic
98 109337 RK	R-9,600	Residential 9,600 sq. ft.	SFR-Basic
98 109328 RK	R-9,600	Residential 9,600 sq. ft.	SFR-Basic
98 109334 RK	R-9,600	Residential 9,600 sq. ft.	SFR-Basic
98 109338 RK	R-9,600	Residential 9,600 sq. ft.	SFR-Basic
98 108594 RK	R-9,600	Residential 9,600 sq. ft.	SFR-Basic



Accessory Dwelling Units

Index # - File Name: 1.0022 - Single Family Dwellings Data\_Snohomish County.pdf

98 108593 RK	R-9,600	Residential 9,600 sq. ft.	SFR-Basic
98 107897 RK	R-9,600	Residential 9,600 sq. ft.	Single Family Res-Combo
98 108590 RK	R-9,600	Residential 9,600 sq. ft.	SFR-Basic
98 108589 RK	R-9,600	Residential 9,600 sq. ft.	SFR-Basic
98 106107 RK	R-9,600	Residential 9,600 sq. ft.	Single Family Res-Combo
98 108595 RK	R-9,600	Residential 9,600 sq. ft.	SFR-Basic
98 106108 RK	R-9,600	Residential 9,600 sq. ft.	Single Family Res-Combo
98 103590 RK	R-9,600	Residential 9,600 sq. ft.	SFR-Basic
98 103586 RK	R-9,600	Residential 9,600 sq. ft.	SFR-Basic
98 103587 RK	R-9,600	Residential 9,600 sq. ft.	SFR-Basic
98 104488 RK	R-9,600	Residential 9,600 sq. ft.	SFR-Basic
98 104491 RK	R-9,600	Residential 9,600 sq. ft.	SFR-Basic
98 103674 RK	R-9,600	Residential 9,600 sq. ft.	SFR-Basic
98 103275 RK	R-9,600	Residential 9,600 sq. ft.	SFR-Basic
98 103277 RK	R-9,600	Residential 9,600 sq. ft.	SFR-Basic
98 104486 RK	R-9,600	Residential 9,600 sq. ft.	SFR-Basic
98 104487 RK	R-9,600	Residential 9,600 sq. ft.	SFR-Basic
97 108441 RK	R-9,600	Residential 9,600 sq. ft.	Single Family Res-Combo
98 103588 RK	R-9,600	Residential 9,600 sq. ft.	SFR-Basic
97 108299 RK	R-9,600	Residential 9,600 sq. ft.	Single Family Res-Combo
98 102159 RK	CITY	City	Single Family Res-Combo
98 103462 RK	R-7,200	Residential 7,200 sq. ft.	Single Family Res-Combo
98 102253 RK	R-5	Rural-5 Acre	Single Family Res-Combo
97 111697 RK	R-5	Rural-5 Acre	Single Family Res-Combo
97 111693 RK	R-5	Rural-5 Acre	Single Family Res-Combo
97 111698 RK	R-5	Rural-5 Acre	Single Family Res-Combo
97 111699 RK	R-5	Rural-5 Acre	Single Family Res-Combo
97 111695 RK	R-5	Rural-5 Acre	Single Family Res-Combo
97 111694 RK	R-5	Rural-5 Acre	Single Family Res-Combo
97 111689 RK	R-5	Rural-5 Acre	Single Family Res-Combo
97 111690 RK	R-5	Rural-5 Acre	Single Family Res-Combo
97 111691 RK	R-5	Rural-5 Acre	Single Family Res-Combo
98 101852 RK	R-5	Rural-5 Acre	Single Family Res-Combo
97 111715 RK	UC	Urban Center	SFR-Basic
97 111740 MH	R-5	Rural-5 Acre	Double Wide
98 100105 RK	R-9,600	Residential 9,600 sq. ft.	Duplex-Combo
97 111481 RK	R-5	Rural-5 Acre	Single Family Res-Combo
98 104170 RK	R-5	Rural-5 Acre	Single Family Res-Combo
98 102558 RK	R-5	Rural-5 Acre	Single Family Res-Combo
98 105094 RK	R-8,400	Residential 8,400 sq. ft.	Duplex-Basic
98 100640 RK	R-8,400	Residential 8,400 sq. ft.	SFR-Basic
98 100639 RK	R-8,400	Residential 8,400 sq. ft.	SFR-Basic
98 100636 RK	R-8,400	Residential 8,400 sq. ft.	SFR-Basic
98 100638 RK	R-8,400	Residential 8,400 sq. ft.	SFR-Basic
98 100071 RK	R-8,400	Residential 8,400 sq. ft.	SFR-Basic
98 100072 RK	R-8,400	Residential 8,400 sq. ft.	SFR-Basic
98 101500 RK	R-5	Rural-5 Acre	Single Family Res-Combo

Accessory Dwelling Units

Index # - File Name: 1.0022 - Single Family Dwellings Data\_Snohomish County.pdf

98 100432 MH	R-5	Rural-5 Acre	Triple Wide
98 103833 RK	R-7,200	Residential 7,200 sq. ft.	Single Family Res-Combo
98 101579 RK	CITY	City	Duplex-Combo
98 106580 RK	R-5	Rural-5 Acre	Single Family Res-Combo
98 100854 RK	R-5	Rural-5 Acre	SFR-Basic
97 109246 RK	R-5	Rural-5 Acre	Single Family Res-Combo
98 100009 MH	R-5	Rural-5 Acre	Double Wide
98 100167 MH	F and R	Forestry and Recreation	Double Wide
98 103537 RK	R-5	Rural-5 Acre	Single Family Res-Combo
98 110289 RK	R-5	Rural-5 Acre	Single Family Res-Combo
98 108576 RK	R-5	Rural-5 Acre	Single Family Res-Combo
98 102569 RK	R-5	Rural-5 Acre	Single Family Res-Combo
98 101938 RK	R-5	Rural-5 Acre	Single Family Res-Combo
98 105144 RK	R-5	Rural-5 Acre	Single Family Res-Combo
98 105147 RK	R-5	Rural-5 Acre	Single Family Res-Combo
98 101942 RK	R-5	Rural-5 Acre	SFR-Basic
97 105269 RK	R-5	Rural-5 Acre	Single Family Res-Combo
98 100664 RK	CITY	City	Single Family Res-Combo
98 107978 RK	R-5	Rural-5 Acre	Single Family Res-Combo
98 100961 RK	R-5	Rural-5 Acre	Single Family Res-Combo
98 100877 RK	CITY	City	Duplex-Basic
98 100458 RK	CITY	City	Duplex-Basic
98 102346 RK	R-5	Rural-5 Acre	Single Family Res-Combo
98 101553 RK	R-9,600	Residential 9,600 sq. ft.	SFR-Basic
98 101552 RK	R-9,600	Residential 9,600 sq. ft.	SFR-Basic
98 100544 RK	R-8,400 : R-9,600	Residential 8,400 sq. ft. : Residential 9,600 sq. ft.	Single Family Res-Combo
98 101633 RK	R-8,400	Residential 8,400 sq. ft.	Single Family Res-Combo
98 102462 RK	R-8,400	Residential 8,400 sq. ft.	SFR-Basic
98 102345 RK	R-8,400	Residential 8,400 sq. ft.	SFR-Basic
98 102459 RK	R-8,400	Residential 8,400 sq. ft.	SFR-Basic
98 100974 RK	R-8,400	Residential 8,400 sq. ft.	SFR-Basic
98 100967 RK	R-8,400	Residential 8,400 sq. ft.	Single Family Res-Combo
98 100970 RK	R-8,400	Residential 8,400 sq. ft.	Single Family Res-Combo
98 100971 RK	R-8,400	Residential 8,400 sq. ft.	SFR-Basic
98 104161 RK	R-8,400	Residential 8,400 sq. ft.	Single Family Res-Combo
98 100572 RK	RRT-10	Rural Resource Transition-10 Acre	Single Family Res-Combo
98 107915 MH	R-5	Rural-5 Acre	Double Wide
98 100819 MH	A-10	Agriculture-10 Acre	Double Wide
98 100635 RK	R-5	Rural-5 Acre	Single Family Res-Combo
98 100480 RK	R-5	Rural-5 Acre	Single Family Res-Combo
98 100384 RK	R-5	Rural-5 Acre	Single Family Res-Combo
98 108211 RK	R-8,400	Residential 8,400 sq. ft.	Single Family Res-Combo
98 101138 RK	R-9,600	Residential 9,600 sq. ft.	SFR-Basic
98 101141 RK	R-9,600	Residential 9,600 sq. ft.	SFR-Basic
97 111876 RK	R-9,600	Residential 9,600 sq. ft.	Single Family Res-Combo
97 111872 RK	R-9,600	Residential 9,600 sq. ft.	Single Family Res-Combo
98 108419 RK	R-5	Rural-5 Acre	Single Family Res-Combo

Accessory Dwelling Units

Index # - File Name: 1.0022 - Single Family Dwellings Data\_Snohomish County.pdf

98 100882 RK	R-12,500	Residential 12,500 sq. ft.	Single Family Res-Combo
98 100903 RK	R-9,600	Residential 9,600 sq. ft.	SFR-Basic
98 100916 RK	R-5	Rural-5 Acre	Single Family Res-Combo
98 101939 MH	F	Forestry	Double Wide
98 100919 RK	R-5	Rural-5 Acre	Single Family Res-Combo
98 104418 RK	RC	Rural Conservation	Single Family Res-Combo
98 100197 RK	R-5	Rural-5 Acre	Single Family Res-Combo
98 102095 MH	R-5	Rural-5 Acre	Triple Wide
97 104165 RK	R-5	Rural-5 Acre	Single Family Res-Combo
98 101592 RK	R-9,600	Residential 9,600 sq. ft.	SFR-Basic
98 101594 RK	R-9,600	Residential 9,600 sq. ft.	SFR-Basic
98 101593 RK	R-9,600	Residential 9,600 sq. ft.	SFR-Basic
98 100759 MH	CITY	City	Double Wide
98 101018 MH	CITY	City	MH Park-Double Wide
98 109156 RK	R-5	Rural-5 Acre	Single Family Res-Combo
98 102668 RK	R-5	Rural-5 Acre	SFR-Basic
98 102314 RK	R-5	Rural-5 Acre	Single Family Res-Combo
98 105644 RK	PRD-9,600	Residential 9,600 sq. ft.	SFR-Basic
98 105645 RK	PRD-9,600	Residential 9,600 sq. ft.	SFR-Basic
98 105646 RK	PRD-9,600	Residential 9,600 sq. ft.	SFR-Basic
98 105647 RK	PRD-9,600	Residential 9,600 sq. ft.	SFR-Basic
98 105648 RK	PRD-9,600	Residential 9,600 sq. ft.	SFR-Basic
98 101528 RK	PRD-9,600	Residential 9,600 sq. ft.	SFR-Basic
98 101525 RK	PRD-9,600	Residential 9,600 sq. ft.	SFR-Basic
98 101524 RK	PRD-9,600	Residential 9,600 sq. ft.	SFR-Basic
98 101516 RK	PRD-9,600	Residential 9,600 sq. ft.	SFR-Basic
98 101613 RK	PRD-9,600	Residential 9,600 sq. ft.	SFR-Basic
98 101515 RK	PRD-9,600	Residential 9,600 sq. ft.	SFR-Basic
98 101514 RK	PRD-9,600	Residential 9,600 sq. ft.	SFR-Basic
98 101526 RK	PRD-9,600	Residential 9,600 sq. ft.	SFR-Basic
98 101513 RK	PRD-9,600	Residential 9,600 sq. ft.	SFR-Basic
98 101527 RK	PRD-9,600	Residential 9,600 sq. ft.	SFR-Basic
98 105650 RK	PRD-9,600	Residential 9,600 sq. ft.	SFR-Basic
98 104275 RK	PRD-9,600	Residential 9,600 sq. ft.	SFR-Basic
98 104805 RK	PRD-9,600	Residential 9,600 sq. ft.	SFR-Basic
98 104801 RK	PRD-9,600	Residential 9,600 sq. ft.	SFR-Basic
98 104618 RK	PRD-9,600	Residential 9,600 sq. ft.	SFR-Basic
98 104621 RK	PRD-9,600	Residential 9,600 sq. ft.	SFR-Basic
98 104619 RK	PRD-9,600	Residential 9,600 sq. ft.	SFR-Basic
98 104620 RK	PRD-9,600	Residential 9,600 sq. ft.	SFR-Basic
98 104624 RK	PRD-9,600	Residential 9,600 sq. ft.	SFR-Basic
98 104276 RK	PRD-9,600	Residential 9,600 sq. ft.	SFR-Basic
98 104277 RK	PRD-9,600	Residential 9,600 sq. ft.	SFR-Basic
98 100036 RK	R-5	Rural-5 Acre	Single Family Res-Combo
98 101032 RK	R-5	Rural-5 Acre	Single Family Res-Combo
98 103075 RK	R-5	Rural-5 Acre	Single Family Res-Combo
98 101561 RK	R-5	Rural-5 Acre	Single Family Res-Combo

Accessory Dwelling Units

Index # - File Name: 1.0022 - Single Family Dwellings Data\_Snohomish County.pdf

98 101797 RK	LDMR	Low Density Multiple Reside	Single Family Res-Combo
98 103404 RK	R-5	Rural-5 Acre	Single Family Res-Combo
98 103932 MH	R-5	Rural-5 Acre	Double Wide
98 104218 RK	CITY	City	Duplex-Combo
98 103297 RK	CITY	City	Duplex-Combo
98 103300 RK	CITY	City	Duplex-Combo
98 104052 RK	R-5	Rural-5 Acre	Single Family Res-Combo
98 104059 RK	CITY	City	SFR-Basic
98 108140 RK	R-7,200	Residential 7,200 sq. ft.	SFR-Basic
98 109193 RK	R-7,200	Residential 7,200 sq. ft.	SFR-Basic
98 106799 RK	R-7,200	Residential 7,200 sq. ft.	Single Family Res-Combo
98 104085 RK	PRD SA-1	Suburban Agriculture-1 Acre	Single Family Res-Combo
98 109602 RK	PRD SA-1	Suburban Agriculture-1 Acre	Single Family Res-Combo
98 106568 RK	PRD SA-1	Suburban Agriculture-1 Acre	Single Family Res-Combo
98 104658 RK	PRD SA-1	Suburban Agriculture-1 Acre	Single Family Res-Combo
98 104666 RK	PRD SA-1	Suburban Agriculture-1 Acre	Single Family Res-Combo
98 103351 RK	PRD SA-1	Suburban Agriculture-1 Acre	Single Family Res-Combo
98 103924 RK	R-5	Rural-5 Acre	Single Family Res-Combo
98 105856 RK	R-5	Rural-5 Acre	Single Family Res-Combo
98 103541 RK	R-5	Rural-5 Acre	Single Family Res-Combo
98 103555 RK	R-5	Rural-5 Acre	Single Family Res-Combo
98 103759 RK	R-5	Rural-5 Acre	Single Family Res-Combo
98 103903 RK	CITY	City	Single Family Res-Combo
98 104087 RK	PRD SA-1	Suburban Agriculture-1 Acre	SFR-Basic
98 104246 RK	PRD SA-1	Suburban Agriculture-1 Acre	Single Family Res-Combo
98 109069 RK	PRD SA-1	Suburban Agriculture-1 Acre	Single Family Res-Combo
98 106444 RK	PRD SA-1	Suburban Agriculture-1 Acre	SFR-Basic
98 104132 RK	PRD SA-1	Suburban Agriculture-1 Acre	Single Family Res-Combo
98 104135 RK	PRD SA-1	Suburban Agriculture-1 Acre	SFR-Basic
98 106570 RK	PRD SA-1	Suburban Agriculture-1 Acre	Single Family Res-Combo
98 106572 RK	PRD SA-1	Suburban Agriculture-1 Acre	Single Family Res-Combo
98 104753 RK	CITY	City	SFR-Basic
98 104771 RK	CITY	City	SFR-Basic
98 104754 RK	CITY	City	SFR-Basic
98 104767 RK	CITY	City	SFR-Basic
98 104755 RK	CITY	City	SFR-Basic
98 104772 RK	CITY	City	SFR-Basic
98 104757 RK	CITY	City	SFR-Basic
98 104768 RK	CITY	City	SFR-Basic
98 104758 RK	CITY	City	SFR-Basic
98 104566 RK	R-5	Rural-5 Acre	Single Family Res-Combo
98 104773 RK	CITY	City	SFR-Basic
98 104759 RK	CITY	City	SFR-Basic
98 104760 RK	CITY	City	SFR-Basic
98 104770 RK	CITY	City	SFR-Basic
98 104774 RK	CITY	City	SFR-Basic
98 103865 RK	CITY	City	SFR-Basic

Accessory Dwelling Units

Index # - File Name: 1.0022 - Single Family Dwellings Data\_Snohomish County.pdf

98 103867 RK	CITY	City	SFR-Basic
98 103868 RK	CITY	City	SFR-Basic
98 103861 RK	CITY	City	SFR-Basic
98 103869 RK	CITY	City	SFR-Basic
98 103870 RK	CITY	City	SFR-Basic
98 103862 RK	CITY	City	SFR-Basic
97 111553 RK	CITY	City	Single Family Res-Combo
98 103863 RK	CITY	City	SFR-Basic
98 103871 RK	CITY	City	SFR-Basic
98 103872 RK	CITY	City	SFR-Basic
98 103906 RK	CITY	City	Single Family Res-Combo
98 103850 RK	CITY	City	SFR-Basic
97 110410 RK	CITY	City	Single Family Res-Combo
98 103842 RK	CITY	City	SFR-Basic
98 103843 RK	CITY	City	SFR-Basic
98 103846 RK	CITY	City	SFR-Basic
98 103845 RK	CITY	City	SFR-Basic
98 103844 RK	CITY	City	SFR-Basic
98 103854 RK	CITY	City	SFR-Basic
98 103856 RK	CITY	City	SFR-Basic
98 103847 RK	CITY	City	SFR-Basic
98 103848 RK	CITY	City	SFR-Basic
98 103855 RK	CITY	City	SFR-Basic
98 103849 RK	CITY	City	SFR-Basic
98 104764 RK	CITY	City	SFR-Basic
98 104775 RK	CITY	City	SFR-Basic
98 104765 RK	CITY	City	SFR-Basic
98 104766 RK	CITY	City	SFR-Basic
98 104776 RK	CITY	City	SFR-Basic
98 107790 RK	CITY	City	SFR-Basic
98 107792 RK	CITY	City	SFR-Basic
98 107793 RK	CITY	City	SFR-Basic
98 107796 RK	CITY	City	SFR-Basic
98 107798 RK	CITY	City	SFR-Basic
98 106984 RK	CITY	City	SFR-Basic
98 106990 RK	CITY	City	SFR-Basic
98 106986 RK	CITY	City	SFR-Basic
98 106987 RK	CITY	City	SFR-Basic
98 106991 RK	CITY	City	SFR-Basic
98 106992 RK	CITY	City	SFR-Basic
98 104901 RK	CITY	City	Single Family Res-Combo
98 103951 RK	CITY	City	Single Family Res-Combo
98 104904 RK	CITY	City	Single Family Res-Combo
98 104905 RK	CITY	City	Single Family Res-Combo
98 103952 RK	CITY	City	Single Family Res-Combo
98 104906 RK	CITY	City	Single Family Res-Combo
98 103954 RK	CITY	City	Single Family Res-Combo

Accessory Dwelling Units

Index # - File Name: 1.0022 - Single Family Dwellings Data\_Snohomish County.pdf

98 103955 RK	CITY	City	Single Family Res-Combo
98 103956 RK	CITY	City	Single Family Res-Combo
98 103957 RK	CITY	City	Single Family Res-Combo
98 103958 RK	CITY	City	Single Family Res-Combo
98 103960 RK	CITY	City	Single Family Res-Combo
98 103961 RK	CITY	City	Single Family Res-Combo
98 104902 RK	CITY	City	Single Family Res-Combo
98 104907 RK	CITY	City	Single Family Res-Combo
98 104903 RK	CITY	City	Single Family Res-Combo
98 104908 RK	CITY	City	Single Family Res-Combo
98 106988 RK	CITY	City	SFR-Basic
98 106993 RK	CITY	City	SFR-Basic
98 106989 RK	CITY	City	SFR-Basic
98 103962 RK	CITY	City	Single Family Res-Combo
98 107795 RK	CITY	City	SFR-Basic
98 107800 RK	CITY	City	SFR-Basic
98 107801 RK	CITY	City	SFR-Basic
98 102371 RK	CITY	City	Duplex-Combo
98 102994 RK	R-5	Rural-5 Acre	Single Family Res-Combo
98 104720 RK	F	Forestry	Single Family Res-Combo
98 102919 RK	R-5	Rural-5 Acre	Single Family Res-Combo
98 102910 RK	R-9,600	Residential 9,600 sq. ft.	SFR-Basic
98 102953 RK	R-5	Rural-5 Acre	Single Family Res-Combo
98 104982 RK	R-5	Rural-5 Acre	Single Family Res-Combo
98 106965 RK	R-5	Rural-5 Acre	Single Family Res-Combo
98 102655 RK	R-5	Rural-5 Acre	Single Family Res-Combo
98 109273 RK	R-5	Rural-5 Acre	Single Family Res-Combo
98 103110 RK	R-7,200	Residential 7,200 sq. ft.	SFR-Basic
98 103111 RK	R-7,200	Residential 7,200 sq. ft.	SFR-Basic
98 103121 RK	R-7,200	Residential 7,200 sq. ft.	Single Family Res-Combo
98 103112 RK	R-7,200	Residential 7,200 sq. ft.	SFR-Basic
98 103113 RK	R-7,200	Residential 7,200 sq. ft.	SFR-Basic
98 103114 RK	R-7,200	Residential 7,200 sq. ft.	SFR-Basic
98 103115 RK	R-7,200	Residential 7,200 sq. ft.	SFR-Basic
98 103116 RK	R-7,200	Residential 7,200 sq. ft.	SFR-Basic
98 104401 RK	R-7,200	Residential 7,200 sq. ft.	SFR-Basic
98 103118 RK	R-7,200	Residential 7,200 sq. ft.	SFR-Basic
98 103119 RK	R-7,200	Residential 7,200 sq. ft.	SFR-Basic
98 103120 RK	R-7,200	Residential 7,200 sq. ft.	SFR-Basic
98 103165 RK	R-9,600	Residential 9,600 sq. ft.	SFR-Basic
98 103169 MH	R-5	Rural-5 Acre	Triple Wide
98 103605 RK	PRD-9,600	Residential 9,600 sq. ft.	SFR-Basic
98 103610 RK	PRD-9,600	Residential 9,600 sq. ft.	SFR-Basic
98 103609 RK	PRD-9,600	Residential 9,600 sq. ft.	SFR-Basic
98 103608 RK	PRD-9,600	Residential 9,600 sq. ft.	SFR-Basic
98 103607 RK	PRD-9,600	Residential 9,600 sq. ft.	SFR-Basic
98 103091 RK	PRD-9,600	Residential 9,600 sq. ft.	SFR-Basic

Accessory Dwelling Units

Index # - File Name: 1.0022 - Single Family Dwellings Data\_Snohomish County.pdf

98 103093 RK	PRD-9,600	Residential 9,600 sq. ft.	SFR-Basic
98 103094 RK	PRD-9,600	Residential 9,600 sq. ft.	SFR-Basic
98 103095 RK	PRD-9,600	Residential 9,600 sq. ft.	SFR-Basic
98 103097 RK	PRD-9,600	Residential 9,600 sq. ft.	SFR-Basic
98 103098 RK	PRD-9,600	Residential 9,600 sq. ft.	SFR-Basic
98 103290 RK	PRD-9,600	Residential 9,600 sq. ft.	SFR-Basic
98 103292 RK	PRD-9,600	Residential 9,600 sq. ft.	SFR-Basic
98 103291 RK	PRD-9,600	Residential 9,600 sq. ft.	SFR-Basic
98 103612 RK	PRD-9,600	Residential 9,600 sq. ft.	SFR-Basic
98 103611 RK	PRD-9,600	Residential 9,600 sq. ft.	SFR-Basic
98 103613 RK	PRD-9,600	Residential 9,600 sq. ft.	SFR-Basic
98 104252 RK	PRD-9,600	Residential 9,600 sq. ft.	SFR-Basic
98 104254 RK	PRD-9,600	Residential 9,600 sq. ft.	SFR-Basic
98 104255 RK	PRD-9,600	Residential 9,600 sq. ft.	SFR-Basic
98 104256 RK	PRD-9,600	Residential 9,600 sq. ft.	SFR-Basic
98 104257 RK	PRD-9,600	Residential 9,600 sq. ft.	SFR-Basic
98 104258 RK	PRD-9,600	Residential 9,600 sq. ft.	SFR-Basic
98 104601 RK	PRD-9,600	Residential 9,600 sq. ft.	SFR-Basic
98 104600 RK	PRD-9,600	Residential 9,600 sq. ft.	SFR-Basic
98 104598 RK	PRD-9,600	Residential 9,600 sq. ft.	SFR-Basic
98 104596 RK	PRD-9,600	Residential 9,600 sq. ft.	SFR-Basic
98 104602 RK	PRD-9,600	Residential 9,600 sq. ft.	SFR-Basic
98 104595 RK	PRD-9,600	Residential 9,600 sq. ft.	SFR-Basic
98 104594 RK	PRD-9,600	Residential 9,600 sq. ft.	SFR-Basic
98 103096 RK	PRD-9,600	Residential 9,600 sq. ft.	SFR-Basic
98 103606 RK	PRD-9,600	Residential 9,600 sq. ft.	SFR-Basic
98 103614 RK	PRD-9,600	Residential 9,600 sq. ft.	SFR-Basic
98 104253 RK	PRD-9,600	Residential 9,600 sq. ft.	SFR-Basic
98 104599 RK	PRD-9,600	Residential 9,600 sq. ft.	SFR-Basic
98 104597 RK	PRD-9,600	Residential 9,600 sq. ft.	SFR-Basic
98 108643 RK	R-5	Rural-5 Acre	Single Family Res-Combo
98 106672 RK	CITY	City	Single Family Res-Combo
98 104855 RK	R-5	Rural-5 Acre	Single Family Res-Combo
98 103309 RK	R-5	Rural-5 Acre	Single Family Res-Combo
98 104040 RK	R-5	Rural-5 Acre	Single Family Res-Combo
98 104316 RK	R-9,600	Residential 9,600 sq. ft.	Single Family Res-Combo
98 106121 RK	R-5	Rural-5 Acre	Single Family Res-Combo
98 104923 MH	R-5	Rural-5 Acre	Single Wide
98 105480 RK	R-5	Rural-5 Acre	SFR-Basic
98 105478 RK	R-5	Rural-5 Acre	SFR-Basic
98 105336 RK	R-5	Rural-5 Acre	SFR-Basic
98 105338 RK	R-5	Rural-5 Acre	SFR-Basic
97 110100 RK	R-5	Rural-5 Acre	Single Family Res-Combo
98 105481 RK	R-5	Rural-5 Acre	SFR-Basic
98 106435 RK	R-5	Rural-5 Acre	Single Family Res-Combo
98 106431 RK	R-5	Rural-5 Acre	Single Family Res-Combo
98 106434 RK	R-5	Rural-5 Acre	Single Family Res-Combo

Accessory Dwelling Units

Index # - File Name: 1.0022 - Single Family Dwellings Data\_Snohomish County.pdf

98 106433 RK	R-5	Rural-5 Acre	Single Family Res-Combo
98 108547 RK	R-5	Rural-5 Acre	Single Family Res-Combo
98 110095 RK	R-5	Rural-5 Acre	Single Family Res-Combo
98 110475 RK	R-5	Rural-5 Acre	Single Family Res-Combo
98 109909 RK	R-5	Rural-5 Acre	Single Family Res-Combo
98 110096 RK	R-5	Rural-5 Acre	Single Family Res-Combo
98 110097 RK	R-5	Rural-5 Acre	Single Family Res-Combo
98 110477 RK	R-5	Rural-5 Acre	Single Family Res-Combo
98 110098 RK	R-5	Rural-5 Acre	Single Family Res-Combo
98 116175 RK	R-5	Rural-5 Acre	Single Family Res-Combo
98 109911 RK	R-5	Rural-5 Acre	Single Family Res-Combo
98 116173 RK	R-5	Rural-5 Acre	Single Family Res-Combo
98 104231 RK	R-5	Rural-5 Acre	Single Family Res-Combo
98 104232 RK	R-5	Rural-5 Acre	Single Family Res-Combo
98 103968 RK	R-5	Rural-5 Acre	Single Family Res-Combo
98 104233 RK	R-5	Rural-5 Acre	Single Family Res-Combo
98 103970 RK	R-5	Rural-5 Acre	Single Family Res-Combo
98 104235 RK	R-5	Rural-5 Acre	Single Family Res-Combo
98 104671 RK	R-5	Rural-5 Acre	Single Family Res-Combo
98 103491 RK	CITY	City	Single Family Res-Combo
98 108097 RK	R-5	Rural-5 Acre	Single Family Res-Combo
98 103645 RK	R-5	Rural-5 Acre	Single Family Res-Combo
98 103652 MH	MHP	Mobile Home Park	MH Park-Single Wide
98 103649 RK	R-9,600	Residential 9,600 sq. ft.	Single Family Res-Combo
98 103725 RK	RRT-10	Rural Resource Transition-10	Single Family Res-Combo
98 103823 MH	MHP	Mobile Home Park	MH Park-Double Wide
98 103818 MH	MHP	Mobile Home Park	MH Park-Double Wide
98 103722 MH	MHP	Mobile Home Park	MH Park-Double Wide
98 103812 MH	MHP	Mobile Home Park	MH Park-Double Wide
98 103723 MH	MHP	Mobile Home Park	MH Park-Double Wide
98 103811 MH	MHP	Mobile Home Park	MH Park-Double Wide
98 103724 MH	MHP	Mobile Home Park	MH Park-Double Wide
98 103806 MH	MHP	Mobile Home Park	MH Park-Double Wide
98 103726 MH	MHP	Mobile Home Park	MH Park-Double Wide
98 103805 MH	MHP	Mobile Home Park	MH Park-Double Wide
98 103727 MH	MHP	Mobile Home Park	MH Park-Double Wide
98 103804 MH	MHP	Mobile Home Park	MH Park-Double Wide
98 103729 MH	MHP	Mobile Home Park	MH Park-Double Wide
98 103794 MH	MHP	Mobile Home Park	MH Park-Double Wide
98 103770 MH	MHP	Mobile Home Park	MH Park-Double Wide
98 103793 MH	MHP	Mobile Home Park	MH Park-Double Wide
98 103772 MH	MHP	Mobile Home Park	MH Park-Double Wide
98 103792 MH	MHP	Mobile Home Park	MH Park-Double Wide
98 103785 MH	MHP	Mobile Home Park	MH Park-Double Wide
98 103791 MH	MHP	Mobile Home Park	MH Park-Double Wide
98 103786 MH	MHP	Mobile Home Park	MH Park-Double Wide
98 103790 MH	MHP	Mobile Home Park	MH Park-Double Wide



Accessory Dwelling Units

Index # - File Name: 1.0022 - Single Family Dwellings Data\_Snohomish County.pdf

98 103789 MH	MHP	Mobile Home Park	MH Park-Double Wide
98 106150 RK	R-9,600	Residential 9,600 sq. ft.	SFR-Basic
98 106124 RK	RC	Rural Conservation	Single Family Res-Combo
98 106126 MH	RC	Rural Conservation	Double Wide
98 105960 RK	R-9,600	Residential 9,600 sq. ft.	Single Family Res-Combo
98 106039 RK	R-7,200	Residential 7,200 sq. ft.	SFR-Basic
98 106566 RK	PRD-9,600	Residential 9,600 sq. ft.	SFR-Basic
98 106564 RK	PRD-9,600	Residential 9,600 sq. ft.	SFR-Basic
96 107229 RK	PRD-9,600	Residential 9,600 sq. ft.	Single Family Res-Combo
96 107226 RK	PRD-9,600	Residential 9,600 sq. ft.	Single Family Res-Combo
98 106225 RK	R-5	Rural-5 Acre	Single Family Res-Combo
98 107697 MH	R-5	Rural-5 Acre	Single Wide
98 106263 RK	HI	Heavy Industrial	Single Family Res-Combo
98 105827 MH	R-5	Rural-5 Acre	Double Wide
98 106081 RK	R-5	Rural-5 Acre	SFR-Basic
98 105899 MH	F	Forestry	Double Wide
98 105918 MH	R-5	Rural-5 Acre	Triple Wide
98 106300 RK	R-9,600	Residential 9,600 sq. ft.	SFR-Basic
98 106301 RK	R-9,600	Residential 9,600 sq. ft.	SFR-Basic
98 106302 RK	R-9,600	Residential 9,600 sq. ft.	SFR-Basic
98 106303 RK	R-9,600	Residential 9,600 sq. ft.	SFR-Basic
98 106304 RK	R-9,600	Residential 9,600 sq. ft.	SFR-Basic
98 106306 RK	R-9,600	Residential 9,600 sq. ft.	SFR-Basic
98 106307 RK	R-9,600	Residential 9,600 sq. ft.	SFR-Basic
98 106308 RK	R-9,600	Residential 9,600 sq. ft.	SFR-Basic
98 106309 RK	R-9,600	Residential 9,600 sq. ft.	SFR-Basic
98 106310 RK	R-9,600	Residential 9,600 sq. ft.	SFR-Basic
98 106536 RK	R-9,600	Residential 9,600 sq. ft.	SFR-Basic
98 106535 RK	R-9,600	Residential 9,600 sq. ft.	SFR-Basic
98 106311 RK	R-9,600	Residential 9,600 sq. ft.	SFR-Basic
98 106369 MH	R-5	Rural-5 Acre	Double Wide
98 106316 RK	R-9,600	Residential 9,600 sq. ft.	Single Family Res-Combo
98 106319 RK	R-9,600	Residential 9,600 sq. ft.	SFR-Basic
98 106318 RK	R-9,600	Residential 9,600 sq. ft.	Single Family Res-Combo
98 106466 RK	R-9,600	Residential 9,600 sq. ft.	SFR-Basic
98 106323 RK	R-9,600	Residential 9,600 sq. ft.	SFR-Basic
98 150678 RK	R-9,600	Residential 9,600 sq. ft.	SFR-Basic
98 106320 RK	R-9,600	Residential 9,600 sq. ft.	SFR-Basic
98 106464 RK	R-9,600	Residential 9,600 sq. ft.	SFR-Basic
98 110357 RK	R-9,600	Residential 9,600 sq. ft.	SFR-Basic
98 150673 RK	R-9,600	Residential 9,600 sq. ft.	SFR-Basic
98 116329 RK	R-9,600	Residential 9,600 sq. ft.	SFR-Basic
98 106321 RK	R-9,600	Residential 9,600 sq. ft.	SFR-Basic
98 116326 RK	R-9,600	Residential 9,600 sq. ft.	SFR-Basic
98 106322 RK	R-9,600	Residential 9,600 sq. ft.	SFR-Basic
98 106699 MH	R-5	Rural-5 Acre	Double Wide
98 106446 RK	R-5	Rural-5 Acre	Single Family Res-Combo

Accessory Dwelling Units

Index # - File Name: 1.0022 - Single Family Dwellings Data\_Snohomish County.pdf

98 150479 RK	CITY	City	SFR-Basic
98 109351 RK	CITY	City	Single Family Res-Combo
98 150480 RK	CITY	City	SFR-Basic
98 105905 RK	CITY	City	SFR-Basic
98 105908 RK	CITY	City	SFR-Basic
98 105906 RK	CITY	City	SFR-Basic
98 105618 RK	CITY	City	SFR-Basic
98 105628 RK	CITY	City	SFR-Basic
98 105629 RK	CITY	City	SFR-Basic
98 105911 RK	CITY	City	SFR-Basic
98 105907 RK	CITY	City	SFR-Basic
98 105910 RK	CITY	City	SFR-Basic
98 110354 RK	CITY	City	SFR-Basic
98 105600 RK	CITY	City	SFR-Basic
98 105619 RK	CITY	City	SFR-Basic
98 105601 RK	CITY	City	SFR-Basic
98 105603 RK	CITY	City	SFR-Basic
98 105630 RK	CITY	City	SFR-Basic
98 105604 RK	CITY	City	SFR-Basic
98 105605 RK	CITY	City	SFR-Basic
98 105606 RK	CITY	City	SFR-Basic
98 105620 RK	CITY	City	SFR-Basic
98 105631 RK	CITY	City	SFR-Basic
98 105632 RK	CITY	City	SFR-Basic
98 108010 RK	CITY	City	Single Family Res-Combo
98 108350 RK	CITY	City	Single Family Res-Combo
98 106552 RK	CITY	City	SFR-Basic
98 105901 RK	CITY	City	SFR-Basic
98 105909 RK	CITY	City	SFR-Basic
98 105903 RK	CITY	City	SFR-Basic
98 106556 RK	CITY	City	SFR-Basic
98 104460 RK	R-5	Rural-5 Acre	Single Family Res-Combo
98 104937 RK	R-5	Rural-5 Acre	Single Family Res-Combo
98 105598 RK	R-5	Rural-5 Acre	Single Family Res-Combo
98 105335 RK	R-5	Rural-5 Acre	Single Family Res-Combo
98 105477 RK	R-5	Rural-5 Acre	Single Family Res-Combo
98 105526 MH	R-12,500	Residential 12,500 sq. ft.	Double Wide
98 105534 RK	R-5	Rural-5 Acre	Single Family Res-Combo
98 103274 RK	MR	Multiple Residential	Single Family Res-Combo
98 105651 RK	R-5	Rural-5 Acre	Single Family Res-Combo
98 107601 RK	R-5	Rural-5 Acre	Single Family Res-Combo
98 107892 RK	PRD-9,600	Residential 9,600 sq. ft.	Single Family Res-Combo
98 106789 RK	PRD-9,600	Residential 9,600 sq. ft.	Single Family Res-Combo
98 106781 RK	PRD-9,600	Residential 9,600 sq. ft.	Single Family Res-Combo
98 116652 RK	PRD-9,600	Residential 9,600 sq. ft.	Single Family Res-Combo
98 107081 RK	PRD-9,600	Residential 9,600 sq. ft.	SFR-Basic
98 107709 RK	PRD-9,600	Residential 9,600 sq. ft.	SFR-Basic

Accessory Dwelling Units

Index # - File Name: 1.0022 - Single Family Dwellings Data\_Snohomish County.pdf

98 106786 RK	PRD-9,600	Residential 9,600 sq. ft.	Single Family Res-Combo
98 116647 RK	PRD-9,600	Residential 9,600 sq. ft.	Single Family Res-Combo
98 107082 RK	PRD-9,600	Residential 9,600 sq. ft.	Single Family Res-Combo
98 109667 RK	PRD-9,600	Residential 9,600 sq. ft.	Single Family Res-Combo
98 109664 RK	PRD-9,600	Residential 9,600 sq. ft.	SFR-Basic
98 102914 RK	R-5	Rural-5 Acre	Single Family Res-Combo
98 104013 RK	R-5	Rural-5 Acre	Single Family Res-Combo
98 104112 MH	R-5	Rural-5 Acre	Triple Wide
98 105142 RK	R-9,600	Residential 9,600 sq. ft.	Single Family Res-Combo
98 107250 RK	R-9,600	Residential 9,600 sq. ft.	Single Family Res-Combo
98 107256 RK	R-9,600	Residential 9,600 sq. ft.	Single Family Res-Combo
98 107257 RK	R-9,600	Residential 9,600 sq. ft.	Single Family Res-Combo
98 109826 RK	R-9,600	Residential 9,600 sq. ft.	SFR-Basic
98 107254 RK	R-9,600	Residential 9,600 sq. ft.	Single Family Res-Combo
98 109824 RK	R-9,600	Residential 9,600 sq. ft.	SFR-Basic
98 109823 RK	R-9,600	Residential 9,600 sq. ft.	SFR-Basic
98 107252 RK	R-9,600	Residential 9,600 sq. ft.	Single Family Res-Combo
98 100110 RK	R-9,600	Residential 9,600 sq. ft.	Single Family Res-Combo
98 100103 RK	R-9,600	Residential 9,600 sq. ft.	Single Family Res-Combo
98 100107 RK	R-9,600	Residential 9,600 sq. ft.	Single Family Res-Combo
98 103573 RK	R-9,600	Residential 9,600 sq. ft.	Single Family Res-Combo
98 105593 RK	R-5	Rural-5 Acre	Single Family Res-Combo
98 106279 RK	R-9,600	Residential 9,600 sq. ft.	Single Family Res-Combo
98 100106 RK	R-9,600	Residential 9,600 sq. ft.	Single Family Res-Combo
98 104210 MH	R-5	Rural-5 Acre	Double Wide
98 108423 RK	R-5	Rural-5 Acre	Single Family Res-Combo
98 104048 MH	R-5	Rural-5 Acre	Double Wide
98 105448 RK	R-5	Rural-5 Acre	Single Family Res-Combo
98 105445 RK	R-5	Rural-5 Acre	Single Family Res-Combo
98 104786 MH	R-5	Rural-5 Acre	Double Wide
98 105300 RK	CITY	City	Duplex-Combo
98 105302 RK	CITY	City	Duplex-Combo
97 104749 RK	CITY	City	Duplex-Combo
98 104339 RK	R-5	Rural-5 Acre	Single Family Res-Combo
98 106828 RK	R-5	Rural-5 Acre	Single Family Res-Combo
98 109293 RK	R-5	Rural-5 Acre	Duplex-Combo
98 109296 RK	R-5	Rural-5 Acre	Duplex-Combo
98 105080 RK	R-9,600	Residential 9,600 sq. ft.	Single Family Res-Combo
98 105084 RK	R-9,600	Residential 9,600 sq. ft.	SFR-Basic
98 105085 RK	R-9,600	Residential 9,600 sq. ft.	SFR-Basic
98 105090 RK	R-9,600	Residential 9,600 sq. ft.	SFR-Basic
98 105089 RK	R-9,600	Residential 9,600 sq. ft.	SFR-Basic
98 105088 RK	R-9,600	Residential 9,600 sq. ft.	SFR-Basic
98 105082 RK	R-9,600	Residential 9,600 sq. ft.	SFR-Basic
98 105086 RK	R-9,600	Residential 9,600 sq. ft.	SFR-Basic
98 105091 RK	R-9,600	Residential 9,600 sq. ft.	SFR-Basic
98 104427 MH	F	Forestry	Triple Wide

Accessory Dwelling Units

Index # - File Name: 1.0022 - Single Family Dwellings Data\_Snohomish County.pdf

98 104347 MH	R-5	Rural-5 Acre	Double Wide
98 106852 RK	R-5	Rural-5 Acre	Single Family Res-Combo
98 105687 RK	R-8,400	Residential 8,400 sq. ft.	Single Family Res-Combo
96 110121 RK	R-7,200	Residential 7,200 sq. ft.	Single Family Res-Combo
98 106374 RK	R-7,200	Residential 7,200 sq. ft.	Single Family Res-Combo
98 104610 RK	R-5	Rural-5 Acre	Single Family Res-Combo
98 104639 RK	CITY	City	SFR-Basic
98 104729 RK	CITY	City	SFR-Basic
98 104732 RK	CITY	City	SFR-Basic
98 107131 RK	CITY	City	Duplex-Combo
98 109429 RK	CITY	City	Duplex-Basic
98 109433 RK	CITY	City	Duplex-Basic
98 105775 RK	CITY	City	Duplex-Combo
98 108654 RK	CITY	City	Duplex-Basic
98 104667 RK	R-5	Rural-5 Acre	Single Family Res-Combo
98 104684 RK	R-5	Rural-5 Acre	Single Family Res-Combo
98 109149 RK	R-9,600	Residential 9,600 sq. ft.	Single Family Res-Combo
98 104739 RK	R-5	Rural-5 Acre	Single Family Res-Combo
98 104809 RK	R-5	Rural-5 Acre	Single Family Res-Combo
98 105294 RK	R-7,200	Residential 7,200 sq. ft.	SFR-Basic
98 104001 RK	R-7,200	Residential 7,200 sq. ft.	Single Family Res-Combo
98 104004 RK	R-7,200	Residential 7,200 sq. ft.	Single Family Res-Combo
98 106579 RK	R-7,200	Residential 7,200 sq. ft.	Single Family Res-Combo
98 106721 RK	R-7,200	Residential 7,200 sq. ft.	Single Family Res-Combo
98 105295 RK	R-7,200	Residential 7,200 sq. ft.	SFR-Basic
98 104984 RK	CITY	City	Duplex-Combo
98 104985 RK	CITY	City	Duplex-Combo
98 105066 RK	R-5	Rural-5 Acre	Single Family Res-Combo
98 105152 MH	MHP	Mobile Home Park	MH Park-Double Wide
98 105157 MH	R-5	Rural-5 Acre	Double Wide
98 105621 RK	CITY	City	SFR-Basic
98 105622 RK	CITY	City	SFR-Basic
98 105607 RK	CITY	City	SFR-Basic
98 105623 RK	CITY	City	SFR-Basic
98 105610 RK	CITY	City	SFR-Basic
98 105624 RK	CITY	City	SFR-Basic
98 105458 RK	CITY	City	Single Family Res-Combo
98 105612 RK	CITY	City	SFR-Basic
98 105625 RK	CITY	City	SFR-Basic
98 105613 RK	CITY	City	SFR-Basic
98 106788 RK	CITY	City	SFR-Basic
98 105614 RK	CITY	City	SFR-Basic
98 105615 RK	CITY	City	SFR-Basic
98 105626 RK	CITY	City	SFR-Basic
98 105616 RK	CITY	City	SFR-Basic
98 105627 RK	CITY	City	SFR-Basic
98 105699 RK	CITY	City	SFR-Basic

Accessory Dwelling Units

Index # - File Name: 1.0022 - Single Family Dwellings Data\_Snohomish County.pdf

98 106266 RK	CITY	City	SFR-Basic
98 106269 RK	CITY	City	SFR-Basic
98 108011 RK	CITY	City	SFR-Basic
98 106137 RK	CITY	City	SFR-Basic
98 106136 RK	CITY	City	SFR-Basic
98 105697 RK	CITY	City	SFR-Basic
98 106135 RK	CITY	City	SFR-Basic
98 105695 RK	CITY	City	SFR-Basic
98 110566 RK	CITY	City	SFR-Basic
98 105904 RK	CITY	City	SFR-Basic
98 106143 RK	CITY	City	SFR-Basic
98 106139 RK	CITY	City	SFR-Basic
98 109104 RK	CITY	City	SFR-Basic
98 109105 RK	CITY	City	SFR-Basic
98 109106 RK	CITY	City	Single Family Res-Combo
98 109107 RK	CITY	City	SFR-Basic
98 106593 RK	R-5	Rural-5 Acre	Single Family Res-Combo
98 102407 RK	R-9,600	Residential 9,600 sq. ft.	Single Family Res-Combo
98 104974 RK	R-5	Rural-5 Acre	Single Family Res-Combo
98 105968 RK	R-5	Rural-5 Acre	Single Family Res-Combo
98 105969 RK	R-5	Rural-5 Acre	Single Family Res-Combo
98 100705 RK	R-5	Rural-5 Acre	Single Family Res-Combo
98 105972 RK	R-5	Rural-5 Acre	Single Family Res-Combo
97 110451 RK	R-5	Rural-5 Acre	Single Family Res-Combo
97 110454 RK	R-5	Rural-5 Acre	Single Family Res-Combo
98 106979 RK	R-5	Rural-5 Acre	Single Family Res-Combo
98 100030 RK	PRD-9,600	Residential 9,600 sq. ft.	SFR-Basic
98 100029 RK	PRD-9,600	Residential 9,600 sq. ft.	SFR-Basic
98 100521 RK	R-5	Rural-5 Acre	Single Family Res-Combo
98 100522 RK	R-5	Rural-5 Acre	Single Family Res-Combo
98 101083 RK	R-5	Rural-5 Acre	Single Family Res-Combo
98 102428 RK	PRD-9,600	Residential 9,600 sq. ft.	SFR-Basic
98 102427 RK	PRD-9,600	Residential 9,600 sq. ft.	SFR-Basic
98 100024 RK	PRD-9,600	Residential 9,600 sq. ft.	SFR-Basic
98 102425 RK	PRD-9,600	Residential 9,600 sq. ft.	SFR-Basic
98 100941 RK	R-5	Rural-5 Acre	SFR-Basic
98 102292 RK	R-5	Rural-5 Acre	SFR-Basic
98 103159 RK	R-5	Rural-5 Acre	Single Family Res-Combo
98 100261 RK	R-5	Rural-5 Acre	Single Family Res-Combo
97 111935 RK	R-5	Rural-5 Acre	SFR-Basic
97 111730 MH	A-10	Agriculture-10 Acre	Double Wide
97 111276 RK	CITY	City	Single Family Res-Combo
97 109338 RK	CITY	City	Single Family Res-Combo
97 111581 RK	CITY	City	Single Family Res-Combo
97 111586 RK	CITY	City	Single Family Res-Combo
97 111584 RK	CITY	City	Single Family Res-Combo
98 100081 MH	A-10	Agriculture-10 Acre	Single Wide

Accessory Dwelling Units

Index # - File Name: 1.0022 - Single Family Dwellings Data\_Snohomish County.pdf

97 110871 MH	R-5	Rural-5 Acre	Single Wide
97 109975 MH	RD	Rural Diversification	Double Wide
98 100046 RK	CITY	City	SFR-Basic
98 100050 RK	CITY	City	SFR-Basic
98 100051 RK	CITY	City	SFR-Basic
98 100052 RK	CITY	City	SFR-Basic
98 102328 RK	CITY	City	SFR-Basic
98 102330 RK	CITY	City	SFR-Basic
98 102332 RK	CITY	City	SFR-Basic
98 102333 RK	CITY	City	SFR-Basic
98 102334 RK	CITY	City	SFR-Basic
98 102651 RK	CITY	City	SFR-Basic
98 102652 RK	CITY	City	SFR-Basic
98 102653 RK	CITY	City	SFR-Basic
98 102640 RK	CITY	City	SFR-Basic
98 102646 RK	CITY	City	SFR-Basic
98 102648 RK	CITY	City	SFR-Basic
98 102326 RK	CITY	City	SFR-Basic
98 102909 RK	R-5	Rural-5 Acre	Single Family Res-Combo
98 105463 RK	R-5	Rural-5 Acre	Single Family Res-Combo
98 103137 RK	R-5	Rural-5 Acre	SFR-Basic
98 105464 RK	R-5	Rural-5 Acre	Single Family Res-Combo
98 105462 RK	R-5	Rural-5 Acre	SFR-Basic
97 111519 RK	R-5	Rural-5 Acre	Single Family Res-Combo
97 111520 RK	R-5	Rural-5 Acre	Single Family Res-Combo
98 105135 RK	R-5	Rural-5 Acre	Single Family Res-Combo
98 102130 RK	R-5	Rural-5 Acre	Single Family Res-Combo
98 101708 RK	R-7,200	Residential 7,200 sq. ft.	SFR-Basic
97 111599 RK	CITY	City	Single Family Res-Combo
97 107360 MH	RD	Rural Diversification	Single Wide
98 103536 MH	F	Forestry	Double Wide
98 106378 RK	R-5 : RC	Rural Conservation : Rural-5	Single Family Res-Combo
97 108128 MH	R-5	Rural-5 Acre	Single Wide
98 150570 RK	R-5	Rural-5 Acre	Single Family Res-Combo
98 102998 RK	R-5 : RC	Rural Conservation : Rural-5	Single Family Res-Combo
98 103000 RK	R-5 : RC	Rural Conservation : Rural-5	Single Family Res-Combo
98 102944 RK	RC	Rural Conservation	Single Family Res-Combo
98 102999 RK	RC	Rural Conservation	Single Family Res-Combo
98 103005 RK	RC	Rural Conservation	Single Family Res-Combo
98 102649 RK	CITY	City	SFR-Basic
98 102650 RK	CITY	City	SFR-Basic
98 103378 RK	RRT-10	Rural Resource Transition-1	Single Family Res-Combo
98 100680 RK	RRT-10	Rural Resource Transition-1	Single Family Res-Combo
98 101841 RK	CITY	City	SFR-Basic
98 100700 RK	CITY	City	SFR-Basic
98 100708 RK	CITY	City	SFR-Basic
98 101844 RK	CITY	City	SFR-Basic

Accessory Dwelling Units

Index # - File Name: 1.0022 - Single Family Dwellings Data\_Snohomish County.pdf

98 101845 RK	CITY	City	SFR-Basic
98 101843 RK	CITY	City	SFR-Basic
98 100707 RK	CITY	City	SFR-Basic
98 100704 RK	CITY	City	SFR-Basic
97 111925 RK	CITY	City	Single Family Res-Combo
97 111168 RK	CITY	City	Single Family Res-Combo
97 111417 RK	CITY	City	Single Family Res-Combo
97 111170 RK	CITY	City	Single Family Res-Combo
97 111418 RK	CITY	City	Single Family Res-Combo
97 110998 RK	CITY	City	Single Family Res-Combo
97 111000 RK	CITY	City	Single Family Res-Combo
98 101762 RK	CITY	City	Single Family Res-Combo
98 101763 RK	CITY	City	Single Family Res-Combo
98 101162 RK	CITY	City	Single Family Res-Combo
98 101163 RK	CITY	City	Single Family Res-Combo
98 101165 RK	CITY	City	Single Family Res-Combo
98 101164 RK	CITY	City	Single Family Res-Combo
98 101766 RK	CITY	City	Single Family Res-Combo
97 108379 MH	F	Forestry	Double Wide
98 101780 RK	R-5	Rural-5 Acre	Single Family Res-Combo
98 101167 RK	R-5	Rural-5 Acre	SFR-Basic
98 101166 RK	R-5	Rural-5 Acre	Single Family Res-Combo
98 104841 RK	R-5	Rural-5 Acre	SFR-Basic
98 104846 RK	R-5	Rural-5 Acre	SFR-Basic
98 104845 RK	R-5	Rural-5 Acre	SFR-Basic
98 101782 RK	R-5	Rural-5 Acre	SFR-Basic
97 111610 RK	R-5	Rural-5 Acre	Single Family Res-Combo
97 111607 RK	R-5	Rural-5 Acre	Single Family Res-Combo
98 104840 RK	R-5	Rural-5 Acre	SFR-Basic
97 108087 RK	R-5	Rural-5 Acre	Single Family Res-Combo
98 100568 RK	R-5	Rural-5 Acre	Single Family Res-Combo
98 110060 RK	CITY	City	Single Family Res-Combo
97 111018 MH	R-5	Rural-5 Acre	Double Wide
98 102048 RK	R-5	Rural-5 Acre	SFR-Basic
98 107671 RK	R-5	Rural-5 Acre	Single Family Res-Combo
98 103101 RK	R-5	Rural-5 Acre	SFR-Basic
98 103103 RK	R-5	Rural-5 Acre	Single Family Res-Combo
98 100246 RK	LDMR	Low Density Multiple Reside Duplex-Combo	
98 100247 RK	LDMR	Low Density Multiple Reside Duplex-Basic	
98 100248 RK	LDMR	Low Density Multiple Reside Duplex-Basic	
98 102467 RK	R-5	Rural-5 Acre	Single Family Res-Combo
98 102469 RK	R-5	Rural-5 Acre	Single Family Res-Combo
98 105014 RK	R-5	Rural-5 Acre	Single Family Res-Combo
98 101073 RK	R-5	Rural-5 Acre	Single Family Res-Combo
98 101065 RK	R-5	Rural-5 Acre	Single Family Res-Combo
98 101069 RK	R-5	Rural-5 Acre	Single Family Res-Combo
97 110547 MH	R-5	Rural-5 Acre	Double Wide

Accessory Dwelling Units

Index # - File Name: 1.0022 - Single Family Dwellings Data\_Snohomish County.pdf

97 111700 RK	R-5	Rural-5 Acre	Single Family Res-Combo
98 100323 RK	R-5	Rural-5 Acre	Single Family Res-Combo
97 110474 RK	R-5	Rural-5 Acre	Single Family Res-Combo
98 109745 RK	R-5	Rural-5 Acre	Single Family Res-Combo
98 105122 RK	R-5	Rural-5 Acre	Single Family Res-Combo
98 100429 RK	R-5	Rural-5 Acre	Single Family Res-Combo
97 110284 RK	R-7,200	Residential 7,200 sq. ft.	Single Family Res-Combo
98 106224 RK	PRD-9,600	Residential 9,600 sq. ft.	SFR-Basic
98 101786 RK	PRD-9,600	Residential 9,600 sq. ft.	SFR-Basic
98 102574 RK	PRD-9,600	Residential 9,600 sq. ft.	SFR-Basic
98 102580 RK	PRD-9,600	Residential 9,600 sq. ft.	Single Family Res-Combo
98 103482 RK	PRD-9,600	Residential 9,600 sq. ft.	SFR-Basic
98 104848 RK	PRD-9,600	Residential 9,600 sq. ft.	Single Family Res-Combo
98 100236 RK	PRD-9,600	Residential 9,600 sq. ft.	SFR-Basic
98 100459 RK	PRD-9,600	Residential 9,600 sq. ft.	SFR-Basic
98 100462 RK	PRD-9,600	Residential 9,600 sq. ft.	SFR-Basic
98 102941 RK	PRD-9,600	Residential 9,600 sq. ft.	SFR-Basic
98 101931 RK	PRD-9,600	Residential 9,600 sq. ft.	SFR-Basic
98 100461 RK	PRD-9,600	Residential 9,600 sq. ft.	SFR-Basic
98 105320 RK	PRD-9,600	Residential 9,600 sq. ft.	SFR-Basic
98 101932 RK	PRD-9,600	Residential 9,600 sq. ft.	SFR-Basic
98 101707 RK	PRD-9,600	Residential 9,600 sq. ft.	SFR-Basic
98 100853 RK	PRD-9,600	Residential 9,600 sq. ft.	Single Family Res-Combo
98 102947 RK	PRD-9,600	Residential 9,600 sq. ft.	Single Family Res-Combo
98 101934 RK	PRD-9,600	Residential 9,600 sq. ft.	SFR-Basic
98 106227 RK	PRD-9,600	Residential 9,600 sq. ft.	SFR-Basic
98 106643 MH	R-5	Rural-5 Acre	Double Wide
98 106226 RK	PRD-9,600	Residential 9,600 sq. ft.	SFR-Basic
98 102850 RK	R-5	Rural-5 Acre	Single Family Res-Combo
98 110733 MH	CITY	City	MH Park-Double Wide
98 116470 MH	CITY	City	Double Wide
98 101966 RK	R-12,500	Residential 12,500 sq. ft.	Single Family Res-Combo
98 101796 MH	CITY	City	MH Park-Double Wide
98 104761 RK	R-5	Rural-5 Acre	Single Family Res-Combo
98 103898 MH	R-5	Rural-5 Acre	Double Wide
97 109659 RK	R-8,400	Residential 8,400 sq. ft.	Single Family Res-Combo
98 100948 MH	CITY	City	MH Park-Double Wide
98 100119 MH	CITY	City	MH Park-Double Wide
98 110251 MH	CITY	City	MH Park-Double Wide
98 108820 MH	CITY	City	MH Park-Double Wide
97 109596 MH	R-5	Rural-5 Acre	Double Wide
98 150807 MH	CITY	City	MH Park-Double Wide
98 100930 RK	R-5	Rural-5 Acre	Single Family Res-Combo
98 101444 RK	R-5	Rural-5 Acre	Single Family Res-Combo
98 101441 RK	R-5	Rural-5 Acre	Single Family Res-Combo
98 106824 MH	CITY	City	MH Park-Double Wide
98 108817 MH	CITY	City	MH Park-Double Wide



Accessory Dwelling Units

Index # - File Name: 1.0022 - Single Family Dwellings Data\_Snohomish County.pdf

98 104683 RK	CITY	City	Duplex-Combo
97 109436 MH	F	Forestry	Double Wide
98 102068 MH	R-5	Rural-5 Acre	Double Wide
97 111534 MH	R-5	Rural-5 Acre	Double Wide
98 107728 MH	R-5	Rural-5 Acre	Double Wide
98 102070 MH	R-5	Rural-5 Acre	Double Wide
97 110332 MH	R-5	Rural-5 Acre	Double Wide
98 101913 RK	R-5	Rural-5 Acre	Single Family Res-Combo
98 100471 RK	PRD-9,600	Residential 9,600 sq. ft.	SFR-Basic
98 100469 RK	PRD-9,600	Residential 9,600 sq. ft.	SFR-Basic
98 100474 RK	PRD-9,600	Residential 9,600 sq. ft.	SFR-Basic
98 100118 RK	PRD-9,600	Residential 9,600 sq. ft.	Single Family Res-Combo
98 101454 RK	PRD-9,600	Residential 9,600 sq. ft.	SFR-Basic
98 100468 RK	PRD-9,600	Residential 9,600 sq. ft.	SFR-Basic
98 100573 RK	PRD-9,600	Residential 9,600 sq. ft.	Single Family Res-Combo
98 100892 RK	PRD-9,600	Residential 9,600 sq. ft.	SFR-Basic
98 100893 RK	PRD-9,600	Residential 9,600 sq. ft.	SFR-Basic
98 100894 RK	PRD-9,600	Residential 9,600 sq. ft.	SFR-Basic
98 101447 RK	PRD-9,600	Residential 9,600 sq. ft.	SFR-Basic
98 101451 RK	PRD-9,600	Residential 9,600 sq. ft.	SFR-Basic
98 101450 RK	PRD-9,600	Residential 9,600 sq. ft.	SFR-Basic
98 101448 RK	PRD-9,600	Residential 9,600 sq. ft.	SFR-Basic
98 101449 RK	PRD-9,600	Residential 9,600 sq. ft.	SFR-Basic
98 101088 RK	PRD-9,600	Residential 9,600 sq. ft.	SFR-Basic
98 101089 RK	PRD-9,600	Residential 9,600 sq. ft.	SFR-Basic
98 100061 RK	PRD-9,600	Residential 9,600 sq. ft.	SFR-Basic
98 100057 RK	PRD-9,600	Residential 9,600 sq. ft.	SFR-Basic
98 100058 RK	PRD-9,600	Residential 9,600 sq. ft.	SFR-Basic
98 100059 RK	PRD-9,600	Residential 9,600 sq. ft.	SFR-Basic
98 100060 RK	PRD-9,600	Residential 9,600 sq. ft.	SFR-Basic
98 100063 RK	PRD-9,600	Residential 9,600 sq. ft.	SFR-Basic
98 104216 RK	MR	Multiple Residential	SFR-Basic
98 104208 RK	MR	Multiple Residential	Single Family Res-Combo
98 104215 RK	MR	Multiple Residential	SFR-Basic
98 105692 RK	R-5	Rural-5 Acre	Single Family Res-Combo
98 100795 RK	LDMR	Low Density Multiple Reside	Single Family Res-Combo
97 108750 MH	R-5	Rural-5 Acre	Double Wide
97 110065 RK	R-5	Rural-5 Acre	Single Family Res-Combo
98 100222 RK	R-8,400	Residential 8,400 sq. ft.	Duplex-Basic
97 111914 RK	R-8,400	Residential 8,400 sq. ft.	Duplex-Basic
98 108645 RK	RC	Rural Conservation	Single Family Res-Combo
98 102493 RK	R-5	Rural-5 Acre	Single Family Res-Combo
98 104762 MH	R-5	Rural-5 Acre	Double Wide
97 108391 RK	CITY	City	SFR-Basic
97 108393 RK	CITY	City	SFR-Basic
97 108394 RK	CITY	City	SFR-Basic
98 102019 RK	R-5	Rural-5 Acre	SFR-Basic

Accessory Dwelling Units

Index # - File Name: 1.0022 - Single Family Dwellings Data\_Snohomish County.pdf

98 101892 RK	CITY	City	Single Family Res-Combo
98 101723 RK	R-5	Rural-5 Acre	Single Family Res-Combo
97 108923 RK	CITY	City	Duplex-Combo
97 108932 RK	CITY	City	Duplex-Combo
98 105363 RK	R-5	Rural-5 Acre	Single Family Res-Combo
98 103647 RK	CITY	City	Single Family Res-Combo
98 102927 RK	CITY	City	SFR-Basic
97 111782 RK	CITY	City	SFR-Basic
98 106329 RK	R-5	Rural-5 Acre	Single Family Res-Combo
98 108189 RK	R-5	Rural-5 Acre	Single Family Res-Combo
98 106331 RK	R-5	Rural-5 Acre	Single Family Res-Combo
98 105420 RK	R-5	Rural-5 Acre	Single Family Res-Combo
98 100156 RK	R-5	Rural-5 Acre	Single Family Res-Combo
98 106569 RK	R-5	Rural-5 Acre	Single Family Res-Combo
98 106957 RK	R-5	Rural-5 Acre	Single Family Res-Combo
98 109454 RK	R-5	Rural-5 Acre	Single Family Res-Combo
97 111783 RK	CITY	City	SFR-Basic
98 106325 RK	PRD SA-1	Suburban Agriculture-1 Acre	Single Family Res-Combo
98 109208 RK	R-5	Rural-5 Acre	Single Family Res-Combo
98 101894 RK	CITY	City	Single Family Res-Combo
98 107160 RK	R-5	Rural-5 Acre	Single Family Res-Combo
98 108552 RK	R-5	Rural-5 Acre	Single Family Res-Combo
98 108553 RK	R-5	Rural-5 Acre	Single Family Res-Combo
98 108553 001 00 RK	R-5	Rural-5 Acre	Single Family Res-Combo
98 104167 RK	PRD SA-1	Suburban Agriculture-1 Acre	Single Family Res-Combo
98 101045 RK	PRD SA-1	Suburban Agriculture-1 Acre	Single Family Res-Combo
97 111066 RK	PRD SA-1	Suburban Agriculture-1 Acre	Single Family Res-Combo
98 102563 RK	PRD SA-1	Suburban Agriculture-1 Acre	Single Family Res-Combo
98 101816 RK	PRD SA-1	Suburban Agriculture-1 Acre	Single Family Res-Combo
98 102041 RK	PRD SA-1	Suburban Agriculture-1 Acre	Single Family Res-Combo
98 102685 RK	PRD SA-1	Suburban Agriculture-1 Acre	Single Family Res-Combo
98 100343 RK	PRD SA-1	Suburban Agriculture-1 Acre	Single Family Res-Combo
98 102373 RK	PRD SA-1	Suburban Agriculture-1 Acre	Single Family Res-Combo
98 107582 RK	PRD SA-1	Suburban Agriculture-1 Acre	Single Family Res-Combo
98 104946 RK	PRD SA-1	Suburban Agriculture-1 Acre	Single Family Res-Combo
98 107682 RK	PRD SA-1	Suburban Agriculture-1 Acre	Single Family Res-Combo
98 107863 RK	PRD SA-1	Suburban Agriculture-1 Acre	Single Family Res-Combo
98 108280 RK	PRD SA-1	Suburban Agriculture-1 Acre	Single Family Res-Combo
98 108417 RK	PRD SA-1	Suburban Agriculture-1 Acre	Single Family Res-Combo
98 104203 MH	R-5	Rural-5 Acre	Triple Wide
98 104077 MH	R-5	Rural-5 Acre	Triple Wide
98 101412 RK	R-20,000	Residential 20,000 sq. ft.	Single Family Res-Combo
97 111582 RK	CITY	City	Single Family Res-Combo
98 102239 RK	R-5	Rural-5 Acre	Single Family Res-Combo
97 111187 RK	R-5	Rural-5 Acre	Single Family Res-Combo
98 106101 RK	R-5	Rural-5 Acre	Single Family Res-Combo
98 101043 RK	R-5	Rural-5 Acre	Single Family Res-Combo

Accessory Dwelling Units

Index # - File Name: 1.0022 - Single Family Dwellings Data\_Snohomish County.pdf

98 102603 RK	R-5	Rural-5 Acre	SFR-Basic
98 102605 RK	R-5	Rural-5 Acre	Single Family Res-Combo
98 101417 RK	R-20,000	Residential 20,000 sq. ft.	SFR-Basic
98 102766 RK	R-20,000	Residential 20,000 sq. ft.	SFR-Basic
97 111527 RK	R-20,000	Residential 20,000 sq. ft.	SFR-Basic
97 109200 RK	R-20,000	Residential 20,000 sq. ft.	SFR-Basic
98 100629 RK	PRD-9,600	Residential 9,600 sq. ft.	SFR-Basic
98 102450 RK	PRD-9,600	Residential 9,600 sq. ft.	SFR-Basic
98 101126 RK	PRD-9,600	Residential 9,600 sq. ft.	SFR-Basic
98 100028 RK	PRD-9,600	Residential 9,600 sq. ft.	SFR-Basic
98 100026 RK	PRD-9,600	Residential 9,600 sq. ft.	SFR-Basic
98 102452 RK	PRD-9,600	Residential 9,600 sq. ft.	SFR-Basic
98 102451 RK	PRD-9,600	Residential 9,600 sq. ft.	SFR-Basic
98 100025 RK	PRD-9,600	Residential 9,600 sq. ft.	SFR-Basic
98 101121 RK	PRD-9,600	Residential 9,600 sq. ft.	SFR-Basic
98 101123 RK	PRD-9,600	Residential 9,600 sq. ft.	SFR-Basic
98 101125 RK	PRD-9,600	Residential 9,600 sq. ft.	SFR-Basic
98 101118 RK	PRD-9,600	Residential 9,600 sq. ft.	SFR-Basic
98 100631 RK	PRD-9,600	Residential 9,600 sq. ft.	SFR-Basic
98 101119 RK	PRD-9,600	Residential 9,600 sq. ft.	SFR-Basic
98 100632 RK	PRD-9,600	Residential 9,600 sq. ft.	SFR-Basic
97 110989 RK	R-5	Rural-5 Acre	Single Family Res-Combo
98 102208 RK	R-5	Rural-5 Acre	Single Family Res-Combo
97 106529 RK	R-5	Rural-5 Acre	Single Family Res-Combo
98 110181 RK	R-5	Rural-5 Acre	Single Family Res-Combo
98 116081 RK	R-5	Rural-5 Acre	Single Family Res-Combo
97 106392 RK	WFB	Waterfront Beach	Single Family Res-Combo
98 107186 RK	R-5	Rural-5 Acre	Single Family Res-Combo
98 109855 RK	R-5	Rural-5 Acre	Single Family Res-Combo
98 102777 RK	R-5	Rural-5 Acre	Single Family Res-Combo
98 102780 RK	R-5	Rural-5 Acre	Single Family Res-Combo
98 109873 RK	R-5	Rural-5 Acre	Single Family Res-Combo
98 101568 RK	R-5	Rural-5 Acre	Single Family Res-Combo
98 103912 RK	R-5	Rural-5 Acre	Single Family Res-Combo
97 110649 RK	PRD-9,600	Residential 9,600 sq. ft.	SFR-Basic
97 110647 RK	PRD-9,600	Residential 9,600 sq. ft.	Single Family Res-Combo
98 104915 RK	PRD-9,600	Residential 9,600 sq. ft.	Single Family Res-Combo
97 110648 RK	R-5	Rural-5 Acre	Single Family Res-Combo
97 111495 RK	R-5	Rural-5 Acre	Single Family Res-Combo
98 100219 RK	PRD-9,600	Residential 9,600 sq. ft.	Single Family Res-Combo
97 106439 MH	R-5	Rural-5 Acre	Triple Wide
98 100778 RK	PRD-9,600	Residential 9,600 sq. ft.	SFR-Basic
97 106255 RK	RC	Rural Conservation	Single Family Res-Combo
98 107605 RK	PRD-9,600	Residential 9,600 sq. ft.	Single Family Res-Combo
98 104497 RK	PRD-9,600	Residential 9,600 sq. ft.	Single Family Res-Combo
98 100431 RK	PRD-9,600	Residential 9,600 sq. ft.	Single Family Res-Combo
98 100427 RK	PRD-9,600	Residential 9,600 sq. ft.	Single Family Res-Combo

Accessory Dwelling Units

Index # - File Name: 1.0022 - Single Family Dwellings Data\_Snohomish County.pdf

98 101624 RK	PRD-9,600	Residential 9,600 sq. ft.	Single Family Res-Combo
98 103834 RK	PRD-9,600	Residential 9,600 sq. ft.	Single Family Res-Combo
97 111754 RK	PRD-9,600	Residential 9,600 sq. ft.	Single Family Res-Combo
98 101686 RK	PRD-9,600	Residential 9,600 sq. ft.	Single Family Res-Combo
98 100218 RK	PRD-9,600	Residential 9,600 sq. ft.	Single Family Res-Combo
98 106675 RK	PRD-9,600	Residential 9,600 sq. ft.	Single Family Res-Combo
98 103399 RK	PRD-9,600	Residential 9,600 sq. ft.	SFR-Basic
98 100712 RK	PRD-9,600	Residential 9,600 sq. ft.	Single Family Res-Combo
98 116049 RK	PRD-9,600	Residential 9,600 sq. ft.	Single Family Res-Combo
98 103549 RK	CITY	City	Single Family Res-Combo
98 106547 RK	PRD-9,600	Residential 9,600 sq. ft.	Single Family Res-Combo
97 110646 RK	PRD-9,600	Residential 9,600 sq. ft.	Single Family Res-Combo
97 111762 RK	PRD-9,600	Residential 9,600 sq. ft.	Single Family Res-Combo
98 106548 RK	PRD-9,600	Residential 9,600 sq. ft.	Single Family Res-Combo
98 103600 RK	PRD-9,600	Residential 9,600 sq. ft.	SFR-Basic
98 101170 RK	PRD-9,600	Residential 9,600 sq. ft.	SFR-Basic
98 103339 RK	PRD-9,600	Residential 9,600 sq. ft.	Single Family Res-Combo
98 106557 RK	PRD-9,600	Residential 9,600 sq. ft.	SFR-Basic
98 104917 RK	PRD-9,600	Residential 9,600 sq. ft.	Single Family Res-Combo
98 103520 RK	PRD-9,600	Residential 9,600 sq. ft.	Single Family Res-Combo
98 104914 RK	PRD-9,600	Residential 9,600 sq. ft.	Single Family Res-Combo
97 106021 RK	R-5	Rural-5 Acre	Single Family Res-Combo
98 109277 RK	PRD-9,600	Residential 9,600 sq. ft.	Single Family Res-Combo
98 106546 RK	PRD-9,600	Residential 9,600 sq. ft.	Single Family Res-Combo
98 106545 RK	PRD-9,600	Residential 9,600 sq. ft.	Single Family Res-Combo
98 106543 RK	PRD-9,600	Residential 9,600 sq. ft.	Single Family Res-Combo
98 102287 RK	PRD-9,600	Residential 9,600 sq. ft.	SFR-Basic
98 103599 RK	PRD-9,600	Residential 9,600 sq. ft.	SFR-Basic
98 102642 RK	PRD-9,600	Residential 9,600 sq. ft.	SFR-Basic
98 103342 RK	PRD-9,600	Residential 9,600 sq. ft.	Single Family Res-Combo
98 100752 RK	PRD-9,600	Residential 9,600 sq. ft.	SFR-Basic
98 103601 RK	PRD-9,600	Residential 9,600 sq. ft.	SFR-Basic
98 110525 RK	PRD-9,600	Residential 9,600 sq. ft.	Single Family Res-Combo
98 110524 RK	PRD-9,600	Residential 9,600 sq. ft.	Single Family Res-Combo
98 102285 RK	PRD-9,600	Residential 9,600 sq. ft.	SFR-Basic
98 102644 RK	PRD-9,600	Residential 9,600 sq. ft.	Single Family Res-Combo
98 104591 RK	PRD-9,600	Residential 9,600 sq. ft.	SFR-Basic
98 102282 RK	PRD-9,600	Residential 9,600 sq. ft.	SFR-Basic
98 103341 RK	PRD-9,600	Residential 9,600 sq. ft.	Single Family Res-Combo
98 105767 RK	PRD-9,600	Residential 9,600 sq. ft.	SFR-Basic
98 103603 RK	PRD-9,600	Residential 9,600 sq. ft.	SFR-Basic
98 104589 RK	PRD-9,600	Residential 9,600 sq. ft.	SFR-Basic
98 103679 RK	PRD-9,600	Residential 9,600 sq. ft.	Single Family Res-Combo
98 102286 RK	PRD-9,600	Residential 9,600 sq. ft.	SFR-Basic
98 103597 RK	PRD-9,600	Residential 9,600 sq. ft.	SFR-Basic
98 100249 RK	PRD-9,600	Residential 9,600 sq. ft.	SFR-Basic
98 103503 RK	PRD-9,600	Residential 9,600 sq. ft.	Single Family Res-Combo

Accessory Dwelling Units

Index # - File Name: 1.0022 - Single Family Dwellings Data\_Snohomish County.pdf

98 103767 RK	PRD-9,600	Residential 9,600 sq. ft.	Single Family Res-Combo
98 103768 RK	PRD-9,600	Residential 9,600 sq. ft.	Single Family Res-Combo
98 102366 RK	PRD-9,600	Residential 9,600 sq. ft.	Single Family Res-Combo
98 102364 RK	PRD-9,600	Residential 9,600 sq. ft.	Single Family Res-Combo
97 111684 RK	PRD-9,600	Residential 9,600 sq. ft.	Single Family Res-Combo
98 106069 RK	PRD-9,600	Residential 9,600 sq. ft.	Single Family Res-Combo
98 103034 RK	PRD-9,600	Residential 9,600 sq. ft.	Single Family Res-Combo
98 108376 MH	R-5	Rural-5 Acre	Triple Wide
98 101682 RK	PRD-9,600	Residential 9,600 sq. ft.	Single Family Res-Combo
98 108300 RK	R-5	Rural-5 Acre	Single Family Res-Combo
97 105750 RK	R-5	Rural-5 Acre	Single Family Res-Combo
98 108949 RK	R-5	Rural-5 Acre	Single Family Res-Combo
98 106465 MH	RRT-10	Rural Resource Transition-10	Triple Wide
98 101168 RK	A-10	Agriculture-10 Acre	Single Family Res-Combo
98 100992 RK	R-5	Rural-5 Acre	Single Family Res-Combo
98 103288 RK	R-5	Rural-5 Acre	Single Family Res-Combo
97 111361 RK	R-5	Rural-5 Acre	Single Family Res-Combo
98 100054 MH	R-5	Rural-5 Acre	Double Wide
97 102185 RK	R-5	Rural-5 Acre	Single Family Res-Combo
98 100977 RK	F	Forestry	Single Family Res-Combo
97 109891 RK	F	Forestry	Single Family Res-Combo
98 100484 RK	R-5	Rural-5 Acre	Single Family Res-Combo
98 116278 RK	F	Forestry	Single Family Res-Combo
97 111346 RK	R-5	Rural-5 Acre	Single Family Res-Combo
96 103735 000 01 RK	R-5	Rural-5 Acre	Single Family Res-Combo
98 108905 RK	R-5	Rural-5 Acre	Accessory Apt Detached-Combo
98 109096 RK	R-5	Rural-5 Acre	Single Family Res-Combo
98 101950 MH	F	Forestry	Single Wide
98 103126 RK	F	Forestry	Single Family Res-Combo
98 116731 MH	R-5	Rural-5 Acre	Double Wide
97 103393 RK	F	Forestry	Single Family Res-Combo
98 101850 RK	R-5	Rural-5 Acre	Single Family Res-Combo
98 101709 RK	R-5	Rural-5 Acre	Single Family Res-Combo
98 108668 RK	R-7,200	Residential 7,200 sq. ft.	Single Family Res-Combo
98 102020 RK	R-5	Rural-5 Acre	SFR-Basic
98 107205 MH	R-5	Rural-5 Acre	Single Wide
98 100867 RK	R-5	Rural-5 Acre	Single Family Res-Combo
97 107747 RK	R-5	Rural-5 Acre	Single Family Res-Combo
98 104133 MH	R-5	Rural-5 Acre	Double Wide
98 103353 RK	R-5	Rural-5 Acre	Single Family Res-Combo
97 109421 RK	R-5	Rural-5 Acre	Accessory Apt Detached-Combo
97 110766 RK	A-10	Agriculture-10 Acre	Single Family Res-Combo
98 150811 RK	F	Forestry	Single Family Res-Combo
98 104681 RK	A-10	Agriculture-10 Acre	Single Family Res-Combo
98 104129 RK	R-5	Rural-5 Acre	Single Family Res-Combo
98 102781 RK	R-5	Rural-5 Acre	Single Family Res-Combo
98 100353 MH	R-5	Rural-5 Acre	Triple Wide

Accessory Dwelling Units

Index # - File Name: 1.0022 - Single Family Dwellings Data\_Snohomish County.pdf

98 107445 RK	R-7,200	Residential 7,200 sq. ft.	Single Family Res-Combo
98 100902 RK	R-9,600	Residential 9,600 sq. ft.	SFR-Basic
96 102041 000 01 MH	R-5	Rural-5 Acre	Single Wide
98 105400 RK	R-5	Rural-5 Acre	Single Family Res-Combo
97 109637 RK	R-5	Rural-5 Acre	Single Family Res-Combo
98 108864 RK	R-8,400	Residential 8,400 sq. ft.	Single Family Res-Combo
98 107865 RK	R-5	Rural-5 Acre	Single Family Res-Combo
98 151128 MH	R-5	Rural-5 Acre	Double Wide
98 116723 RK	R-5	Rural-5 Acre	Single Family Res-Combo
98 100935 RK	R-5	Rural-5 Acre	Accessory Apt Detached-Combo
98 103831 RK	R-5	Rural-5 Acre	Single Family Res-Combo
98 103102 MH	F	Forestry	Double Wide
98 101468 RK	R-5	Rural-5 Acre	Single Family Res-Combo
97 111268 RK	PRD-20,000	Residential 20,000 sq. ft.	Single Family Res-Combo
97 110993 MH	R-5	Rural-5 Acre	Double Wide
98 103349 MH	IP	Industrial Park	Double Wide
98 103025 RK	R-5	Rural-5 Acre	Single Family Res-Combo
98 104959 RK	R-5	Rural-5 Acre	Single Family Res-Combo
98 104670 MH	R-5	Rural-5 Acre	Double Wide
98 100890 RK	F	Forestry	Single Family Res-Combo
98 102854 MH	F	Forestry	Double Wide
98 100177 RK	MR	Multiple Residential	Single Family Res-Combo
98 103412 RK	R-9,600	Residential 9,600 sq. ft.	Single Family Res-Combo
98 102040 RK	R-5	Rural-5 Acre	Single Family Res-Combo
98 107702 RK	R-5	Rural-5 Acre	Single Family Res-Combo
97 111180 RK	R-5	Rural-5 Acre	Single Family Res-Combo
96 105212 000 01 RK	R-5	Rural-5 Acre	Single Family Res-Combo
97 107808 RK	R-5	Rural-5 Acre	Single Family Res-Combo
98 103948 MH	R-5	Rural-5 Acre	Double Wide
98 102675 RK	R-5	Rural-5 Acre	Single Family Res-Combo
98 107591 RK	F	Forestry	Single Family Res-Combo
98 100800 MH	F	Forestry	Single Wide
97 111906 MH	F	Forestry	Triple Wide
98 102350 RK	F	Forestry	Single Family Res-Combo
97 111145 RK	R-9,600	Residential 9,600 sq. ft.	Single Family Res-Combo
98 105023 MH	PRD-20,000(M	Residential 20,000 sq. ft.	Double Wide
98 103595 MH	R-5	Rural-5 Acre	Double Wide
98 101818 MH	R-5	Rural-5 Acre	Double Wide
97 109764 MH	R-5	Rural-5 Acre	Single Wide
98 101583 RK	R-9,600	Residential 9,600 sq. ft.	Single Family Res-Combo
96 104644 000 01 RK	A-10	Agriculture-10 Acre	Single Family Res-Combo
98 100947 MH	F	Forestry	Double Wide
98 100706 MH	F	Forestry	Double Wide
98 110229 RK	R-8,400	Residential 8,400 sq. ft.	Single Family Res-Combo
98 102755 RK	R-8,400	Residential 8,400 sq. ft.	Single Family Res-Combo
98 107758 RK	R-7,200	Residential 7,200 sq. ft.	Single Family Res-Combo
97 107665 RK	R-12,500	Residential 12,500 sq. ft.	Single Family Res-Combo

Accessory Dwelling Units

Index # - File Name: 1.0022 - Single Family Dwellings Data\_Snohomish County.pdf

98 100478 RK	R-7,200	Residential 7,200 sq. ft.	Single Family Res-Combo
97 111717 RK	UC	Urban Center	Single Family Res-Combo
97 111714 RK	UC	Urban Center	SFR-Basic
97 111873 RK	UC	Urban Center	SFR-Basic
97 111880 RK	UC	Urban Center	SFR-Basic
97 111902 RK	UC	Urban Center	Single Family Res-Combo
97 111871 RK	UC	Urban Center	SFR-Basic
98 101730 RK	UC	Urban Center	SFR-Basic
98 101732 RK	UC	Urban Center	SFR-Basic
98 107940 MH	R-8,400	Residential 8,400 sq. ft.	Double Wide
98 101670 RK	R-5	Rural-5 Acre	Single Family Res-Combo
98 105815 MH	R-12,500	Residential 12,500 sq. ft.	Double Wide
98 116642 MH	R-12,500	Residential 12,500 sq. ft.	Double Wide
98 109792 MH	R-12,500	Residential 12,500 sq. ft.	Double Wide
98 105533 RK	R-8,400	Residential 8,400 sq. ft.	Single Family Res-Combo
96 108925 RK	R-5	Rural-5 Acre	Single Family Res-Combo
98 116862 RK	MR	Multiple Residential	SFR-Basic
98 106531 RK	R-5	Rural-5 Acre	Single Family Res-Combo
98 101756 RK	R-5	Rural-5 Acre	Single Family Res-Combo
98 106527 RK	R-5	Rural-5 Acre	SFR-Basic
97 111554 RK	R-5	Rural-5 Acre	Single Family Res-Combo
97 111476 RK	R-5	Rural-5 Acre	Single Family Res-Combo
98 100757 RK	R-5	Rural-5 Acre	Single Family Res-Combo
98 107044 MH	CITY	City	Triple Wide
98 105763 RK	R-5	Rural-5 Acre	Single Family Res-Combo
98 100687 MH	R-5	Rural-5 Acre	Double Wide
98 100771 MH	R-9,600	Residential 9,600 sq. ft.	Double Wide
98 105799 MH	R-5	Rural-5 Acre	Double Wide
98 100329 RK	R-5	Rural-5 Acre	Single Family Res-Combo
98 102852 RK	R-5	Rural-5 Acre	Single Family Res-Combo
97 111636 RK	F	Forestry	Accessory Apt Detached-Combo
97 108908 RK	R-5	Rural-5 Acre	Single Family Res-Combo
98 106686 MH	R-5	Rural-5 Acre	Double Wide
98 106772 MH	R-5	Rural-5 Acre	Double Wide
98 109834 MH	R-5	Rural-5 Acre	Double Wide
97 110736 MH	R-5	Rural-5 Acre	Double Wide
98 102134 MH	R-5	Rural-5 Acre	Double Wide
98 109266 MH	F	Forestry	Single Wide
97 110249 RK	R-5	Rural-5 Acre	Single Family Res-Combo
97 111725 RK	R-5	Rural-5 Acre	Single Family Res-Combo
98 103007 RK	R-5	Rural-5 Acre	Single Family Res-Combo
98 110081 MH	R-5	Rural-5 Acre	Single Wide
98 109224 RK	R-5	Rural-5 Acre	Single Family Res-Combo
98 100002 MH	R-5	Rural-5 Acre	Double Wide
98 106259 MH	R-5	Rural-5 Acre	Double Wide
98 101172 RK	R-5	Rural-5 Acre	Single Family Res-Combo
98 104476 MH	R-5	Rural-5 Acre	Double Wide

Accessory Dwelling Units

Index # - File Name: 1.0022 - Single Family Dwellings Data\_Snohomish County.pdf

98 102393 RK	R-5	Rural-5 Acre	Single Family Res-Combo
98 103179 RK	R-5	Rural-5 Acre	Single Family Res-Combo
98 105730 RK	R-5	Rural-5 Acre	Single Family Res-Combo
98 104473 MH	R-5	Rural-5 Acre	Double Wide
96 102238 000 01 MH	F	Forestry	Double Wide
98 105849 RK	R-5	Rural-5 Acre	Single Family Res-Combo
98 105657 RK	R-5	Rural-5 Acre	Single Family Res-Combo
96 109137 000 01 MH	R-7,200	Residential 7,200 sq. ft.	Double Wide
98 100696 RK	LDMR	Low Density Multiple Reside	Single Family Res-Combo
97 110452 RK	R-5	Rural-5 Acre	Single Family Res-Combo
97 110962 MH	R-5	Rural-5 Acre	Double Wide
98 109093 RK	MR	Multiple Residential	Single Family Res-Combo
98 104346 RK	R-9,600	Residential 9,600 sq. ft.	Single Family Res-Combo
98 107871 RK	A-10	Agriculture-10 Acre	Single Family Res-Combo
96 107371 000 01 MH	CITY	City	Double Wide
97 109984 RK	R-8,400	Residential 8,400 sq. ft.	Single Family Res-Combo
97 111919 RK	CITY	City	Single Family Res-Combo
97 111920 RK	CITY	City	Single Family Res-Combo
98 104508 RK	LDMR	Low Density Multiple Reside	Single Family Res-Combo
98 106388 RK	R-5	Rural-5 Acre	Single Family Res-Combo
98 102120 RK	CITY	City	Single Family Res-Combo
97 111550 RK	R-9,600	Residential 9,600 sq. ft.	Single Family Res-Combo
97 106427 RK	WFB	Waterfront Beach	Single Family Res-Combo
97 106591 RK	WFB	Waterfront Beach	Single Family Res-Combo
98 109503 RK	R-7,200	Residential 7,200 sq. ft.	Duplex-Combo
98 105967 RK	R-7,200	Residential 7,200 sq. ft.	Duplex-Combo
96 105947 RK	R-7,200	Residential 7,200 sq. ft.	Single Family Res-Combo
98 104478 MH	R-7,200	Residential 7,200 sq. ft.	Double Wide
98 102714 MH	R-5	Rural-5 Acre	Double Wide
98 102613 RK	R-8,400	Residential 8,400 sq. ft.	Single Family Res-Combo
98 102098 MH	R-5	Rural-5 Acre	Triple Wide
98 102990 RK	R-5	Rural-5 Acre	Single Family Res-Combo
98 105473 RK	R-8,400	Residential 8,400 sq. ft.	Single Family Res-Combo
98 104414 RK	R-9,600	Residential 9,600 sq. ft.	SFR-Basic
98 103164 RK	R-9,600	Residential 9,600 sq. ft.	SFR-Basic
98 102522 RK	R-9,600	Residential 9,600 sq. ft.	Single Family Res-Combo
98 103615 RK	R-9,600	Residential 9,600 sq. ft.	Single Family Res-Combo
98 100049 RK	PRD-9,600	Residential 9,600 sq. ft.	Single Family Res-Combo
98 100494 RK	CITY	City	Single Family Res-Combo
96 104189 MH	R-5	Rural-5 Acre	Single Wide
98 102929 RK	R-5	Rural-5 Acre	Single Family Res-Combo
98 105659 MH	HI	Heavy Industrial	Double Wide
98 104679 RK	R-20,000	Residential 20,000 sq. ft.	Single Family Res-Combo
98 102807 RK	R-5	Rural-5 Acre	Single Family Res-Combo
98 105359 RK	R-5	Rural-5 Acre	Single Family Res-Combo
98 103004 RK	R-5	Rural-5 Acre	Single Family Res-Combo
98 105274 RK	R-5	Rural-5 Acre	Single Family Res-Combo



Accessory Dwelling Units

Index # - File Name: 1.0022 - Single Family Dwellings Data\_Snohomish County.pdf

98 108899 RK	R-5	Rural-5 Acre	Single Family Res-Combo
97 111612 RK	R-5	Rural-5 Acre	Single Family Res-Combo
98 108088 RK	R-5	Rural-5 Acre	Single Family Res-Combo
98 109554 MH	R-5	Rural-5 Acre	Double Wide
98 106634 MH	RRT-10	Rural Resource Transition-10	Double Wide
98 102794 MH	R-5	Rural-5 Acre	Triple Wide
97 111426 MH	R-5	Rural-5 Acre	Single Wide
98 106330 RK	R-5	Rural-5 Acre	Single Family Res-Combo
98 102131 MH	R-5	Rural-5 Acre	Single Wide
98 108746 MH	R-5	Rural-5 Acre	Double Wide
96 106167 MH	R-5	Rural-5 Acre	Double Wide
97 109919 RK	RRT-10	Rural Resource Transition-10	Accessory Apt Detached-Combo
98 100625 RK	R-5	Rural-5 Acre	Single Family Res-Combo
98 106197 RK	R-5	Rural-5 Acre	Single Family Res-Combo
98 104205 MH	RRT-10	Rural Resource Transition-10	Double Wide
98 108836 MH	R-5	Rural-5 Acre	Double Wide
98 102417 MH	R-5	Rural-5 Acre	Double Wide
98 109295 RK	R-5	Rural-5 Acre	Single Family Res-Combo
96 100323 000 01 RK	R-5	Rural-5 Acre	Single Family Res-Combo
98 107002 RK	R-5	Rural-5 Acre	Single Family Res-Combo
98 106966 RK	R-5	Rural-5 Acre	Single Family Res-Combo
98 103692 MH	RRT-10	Rural Resource Transition-10	Double Wide
98 103388 RK	R-5	Rural-5 Acre	Single Family Res-Combo
98 103817 MH	R-5	Rural-5 Acre	Double Wide
98 100481 RK	CITY	City	Single Family Res-Combo
98 104429 RK	R-5	Rural-5 Acre	Single Family Res-Combo
97 111494 RK	CITY	City	Single Family Res-Combo
98 105592 RK	R-5	Rural-5 Acre	Duplex-Basic
98 107219 MH	R-5	Rural-5 Acre	Double Wide
98 108137 RK	R-5	Rural-5 Acre	Single Family Res-Combo
97 111899 MH	R-5	Rural-5 Acre	Double Wide
98 101802 RK	R-7,200	Residential 7,200 sq. ft.	Single Family Res-Combo
98 101801 RK	R-7,200	Residential 7,200 sq. ft.	Single Family Res-Combo
98 109008 MH	CITY	City	Double Wide
98 100663 RK	R-5	Rural-5 Acre	Single Family Res-Combo
98 101534 RK	R-7,200	Residential 7,200 sq. ft.	Single Family Res-Combo
98 101537 RK	R-7,200	Residential 7,200 sq. ft.	Single Family Res-Combo
98 101803 RK	R-7,200	Residential 7,200 sq. ft.	Single Family Res-Combo
98 101532 RK	R-7,200	Residential 7,200 sq. ft.	Single Family Res-Combo
98 101538 RK	R-7,200	Residential 7,200 sq. ft.	Single Family Res-Combo
98 101530 RK	R-7,200	Residential 7,200 sq. ft.	Single Family Res-Combo
98 106116 RK	R-5	Rural-5 Acre	Single Family Res-Combo
98 105052 RK	R-5	Rural-5 Acre	Single Family Res-Combo
98 100792 RK	R-5	Rural-5 Acre	Duplex-Combo
98 100794 RK	R-5	Rural-5 Acre	Duplex-Combo
98 104179 RK	R-7,200	Residential 7,200 sq. ft.	Single Family Res-Combo
98 103077 RK	R-5	Rural-5 Acre	Single Family Res-Combo

Accessory Dwelling Units

Index # - File Name: 1.0022 - Single Family Dwellings Data\_Snohomish County.pdf

97 111489 RK	R-5	Rural-5 Acre	Single Family Res-Combo
98 101425 RK	R-5	Rural-5 Acre	Single Family Res-Combo
98 102080 RK	R-5	Rural-5 Acre	Single Family Res-Combo
98 110088 RK	CITY	City	Single Family Res-Combo
98 102403 MH	R-5	Rural-5 Acre	Double Wide
98 100668 MH	R-5	Rural-5 Acre	Double Wide
97 109169 MH	R-5	Rural-5 Acre	Single Wide
97 110959 RK	RRT-10	Rural Resource Transition-1	Single Family Res-Combo
98 100880 RK	RRT-10	Rural Resource Transition-1	Single Family Res-Combo
98 101581 RK	RRT-10	Rural Resource Transition-1	SFR-Basic
98 104524 RK	R-5	Rural-5 Acre	SFR-Basic
98 104523 RK	R-5	Rural-5 Acre	SFR-Basic
98 109741 RK	R-5	Rural-5 Acre	Single Family Res-Combo
98 109690 RK	R-5	Rural-5 Acre	Single Family Res-Combo
98 103334 RK	R-5	Rural-5 Acre	SFR-Basic
98 103322 RK	R-5	Rural-5 Acre	SFR-Basic
98 103335 RK	R-5	Rural-5 Acre	SFR-Basic
98 103456 RK	R-5	Rural-5 Acre	SFR-Basic
98 103459 RK	R-5	Rural-5 Acre	SFR-Basic
98 103460 RK	R-5	Rural-5 Acre	SFR-Basic
98 101541 RK	R-5	Rural-5 Acre	Single Family Res-Combo
98 109076 RK	R-5	Rural-5 Acre	SFR-Basic
98 103618 RK	R-5	Rural-5 Acre	SFR-Basic
98 100012 RK	R-5	Rural-5 Acre	SFR-Basic
98 106109 RK	R-5	Rural-5 Acre	SFR-Basic
98 109045 RK	R-5	Rural-5 Acre	Single Family Res-Combo
98 102950 RK	R-5	Rural-5 Acre	Single Family Res-Combo
98 106111 RK	R-5	Rural-5 Acre	SFR-Basic
98 101902 RK	R-5	Rural-5 Acre	Single Family Res-Combo
97 111860 RK	R-5	Rural-5 Acre	Single Family Res-Combo
97 111855 RK	R-5	Rural-5 Acre	Single Family Res-Combo
98 103366 RK	R-5	Rural-5 Acre	SFR-Basic
98 106995 RK	R-5	Rural-5 Acre	Single Family Res-Combo
98 102444 RK	R-5	Rural-5 Acre	SFR-Basic
97 111590 RK	R-5	Rural-5 Acre	Single Family Res-Combo
98 107834 RK	R-5	Rural-5 Acre	SFR-Basic
98 100906 RK	R-5	Rural-5 Acre	Single Family Res-Combo
97 111898 RK	R-5	Rural-5 Acre	SFR-Basic
98 109114 RK	CITY	City	Single Family Res-Combo
98 103760 RK	R-5	Rural-5 Acre	Single Family Res-Combo
97 108264 MH	R-5	Rural-5 Acre	Single Wide
98 100006 MH	R-5	Rural-5 Acre	Double Wide
98 105785 MH	R-5	Rural-5 Acre	Double Wide
98 105838 RK	R-5	Rural-5 Acre	Single Family Res-Combo
98 103888 MH	RRT-10	Rural Resource Transition-1	Double Wide
95 106489 000 01 RK	R-5	Rural-5 Acre	Single Family Res-Combo
98 110717 MH	RRT-10	Rural Resource Transition-1	Double Wide

Accessory Dwelling Units

Index # - File Name: 1.0022 - Single Family Dwellings Data\_Snohomish County.pdf

98 104022 RK	CITY	City	Duplex-Combo
98 100630 MH	R-5	Rural-5 Acre	Double Wide
98 104697 RK	R-5	Rural-5 Acre	Single Family Res-Combo
98 105312 RK	R-5	Rural-5 Acre	Single Family Res-Combo
96 102220 000 01 RK	R-5	Rural-5 Acre	Single Family Res-Combo
98 101024 MH	R-5	Rural-5 Acre	Single Wide
98 104433 MH	R-5	Rural-5 Acre	Double Wide
98 100338 RK	R-5	Rural-5 Acre	SFR-Basic
98 104281 RK	R-5	Rural-5 Acre	Single Family Res-Combo
96 108967 RK	R-5	Rural-5 Acre	Single Family Res-Combo
96 107338 000 01 RK	R-5	Rural-5 Acre	Single Family Res-Combo
98 105655 RK	R-5	Rural-5 Acre	Single Family Res-Combo
98 102021 RK	R-5	Rural-5 Acre	Single Family Res-Combo
98 100578 MH	R-5	Rural-5 Acre	Double Wide
96 108830 RK	R-5	Rural-5 Acre	Single Family Res-Combo
97 110908 MH	R-5	Rural-5 Acre	Double Wide
98 100015 RK	R-5	Rural-5 Acre	Single Family Res-Combo
98 106153 RK	R-5	Rural-5 Acre	Single Family Res-Combo
98 102576 RK	R-5	Rural-5 Acre	Single Family Res-Combo
98 100694 RK	R-5	Rural-5 Acre	SFR-Basic
98 101861 MH	R-5	Rural-5 Acre	Double Wide
98 101923 MH	R-5	Rural-5 Acre	Double Wide
98 104651 RK	R-5	Rural-5 Acre	Single Family Res-Combo
98 103931 MH	R-5	Rural-5 Acre	Triple Wide
98 107242 MH	R-5	Rural-5 Acre	Double Wide
98 106170 RK	R-5	Rural-5 Acre	Single Family Res-Combo
98 108349 RK	R-5	Rural-5 Acre	Single Family Res-Combo
98 106117 RK	R-5	Rural-5 Acre	Single Family Res-Combo
97 111921 RK	R-5	Rural-5 Acre	Single Family Res-Combo
97 107395 RK	R-5	Rural-5 Acre	Single Family Res-Combo
98 102949 RK	R-5	Rural-5 Acre	Single Family Res-Combo
98 103396 RK	R-5	Rural-5 Acre	Single Family Res-Combo
97 107606 RK	R-5	Rural-5 Acre	Single Family Res-Combo
97 111903 RK	R-5	Rural-5 Acre	Accessory Apt Detached-Combo
98 103880 RK	R-5	Rural-5 Acre	Single Family Res-Combo
98 102249 MH	R-5	Rural-5 Acre	Double Wide
97 110733 MH	R-5	Rural-5 Acre	Double Wide
97 111389 MH	R-5	Rural-5 Acre	Double Wide
98 101715 RK	R-5	Rural-5 Acre	Single Family Res-Combo
97 111953 RK	R-5	Rural-5 Acre	Single Family Res-Combo
98 101082 RK	R-5	Rural-5 Acre	SFR-Basic
98 104682 RK	R-5	Rural-5 Acre	Single Family Res-Combo
97 101511 RK	R-5	Rural-5 Acre	SFR-Basic
98 104851 RK	R-5	Rural-5 Acre	Single Family Res-Combo
97 107262 RK	R-5	Rural-5 Acre	Single Family Res-Combo
98 104979 RK	R-5	Rural-5 Acre	Single Family Res-Combo
98 106067 RK	R-5	Rural-5 Acre	Single Family Res-Combo

Accessory Dwelling Units

Index # - File Name: 1.0022 - Single Family Dwellings Data\_Snohomish County.pdf

97 109147 MH	R-5	Rural-5 Acre	Triple Wide
98 100039 RK	R-5	Rural-5 Acre	Single Family Res-Combo
98 108664 MH	R-5	Rural-5 Acre	Double Wide
98 106670 MH	R-5	Rural-5 Acre	Double Wide
97 110345 RK	R-5	Rural-5 Acre	Single Family Res-Combo
98 108448 RK	R-5	Rural-5 Acre	Single Family Res-Combo
98 107025 MH	R-5	Rural-5 Acre	Double Wide
97 111353 RK	R-5	Rural-5 Acre	Single Family Res-Combo
98 108921 RK	R-5	Rural-5 Acre	Duplex-Combo
98 108490 MH	R-5	Rural-5 Acre	Single Wide
98 106285 MH	R-5	Rural-5 Acre	Double Wide
98 109457 MH	R-5	Rural-5 Acre	Triple Wide
98 105726 RK	R-5	Rural-5 Acre	SFR-Basic
97 111074 RK	R-5	Rural-5 Acre	Single Family Res-Combo
98 100448 RK	R-5	Rural-5 Acre	Single Family Res-Combo
98 106621 RK	R-5	Rural-5 Acre	Single Family Res-Combo
98 107770 MH	R-5	Rural-5 Acre	Triple Wide
98 151005 MH	R-5	Rural-5 Acre	MH Park-Double Wide
98 106596 RK	R-5	Rural-5 Acre	Single Family Res-Combo
98 107764 RK	R-5	Rural-5 Acre	Single Family Res-Combo
98 103142 RK	R-5	Rural-5 Acre	Single Family Res-Combo
97 108196 MH	R-5	Rural-5 Acre	Triple Wide
98 116680 RK	CITY	City	Single Family Res-Combo
97 111891 RK	R-5	Rural-5 Acre	Single Family Res-Combo
98 107982 MH	R-5	Rural-5 Acre	Double Wide
97 109136 MH	R-5	Rural-5 Acre	Single Wide
98 110530 RK	R-5	Rural-5 Acre	Single Family Res-Combo
98 104646 RK	R-5	Rural-5 Acre	Single Family Res-Combo
97 109795 MH	R-5	Rural-5 Acre	Double Wide
98 103383 MH	R-5	Rural-5 Acre	Single Wide
98 104931 RK	A-10 : F	Agriculture-10 Acre : Forestr	Single Family Res-Combo
97 109998 MH	A-10	Agriculture-10 Acre	Single Wide
98 103883 MH	R-5	Rural-5 Acre	Triple Wide
97 108837 MH	F : R-5	Forestry : Rural-5 Acre	Double Wide
98 110561 MH	R-5	Rural-5 Acre	Double Wide
98 107745 MH	RC	Rural Conservation	Double Wide
98 104495 RK	R-5	Rural-5 Acre	Single Family Res-Combo
98 102810 MH	R-5	Rural-5 Acre	Double Wide
98 107236 RK	R-5	Rural-5 Acre	Single Family Res-Combo
97 109710 MH	RD	Rural Diversification	Double Wide
98 101834 RK	R-5	Rural-5 Acre	Single Family Res-Combo
98 108641 RK	R-5	Rural-5 Acre	Single Family Res-Combo
97 110915 RK	R-5	Rural-5 Acre	Single Family Res-Combo
97 103516 RK	R-5	Rural-5 Acre	Single Family Res-Combo
98 101857 MH	R-5	Rural-5 Acre	Single Wide
98 101925 RK	R-5	Rural-5 Acre	Single Family Res-Combo
98 102954 MH	R-5	Rural-5 Acre	Double Wide

Accessory Dwelling Units

Index # - File Name: 1.0022 - Single Family Dwellings Data\_Snohomish County.pdf

98 104756 RK	R-5	Rural-5 Acre	Single Family Res-Combo
98 106184 MH	R-5	Rural-5 Acre	Double Wide
97 111517 RK	RB	Rural Business	Duplex-Basic
97 111518 RK	RB	Rural Business	Duplex-Basic
97 109758 RK	R-5	Rural-5 Acre	SFR-Basic
98 101909 MH	R-5	Rural-5 Acre	Double Wide
97 111884 MH	R-5	Rural-5 Acre	Double Wide
98 116251 RK	R-5	Rural-5 Acre	SFR-Basic
97 110645 MH	R-5	Rural-5 Acre	Double Wide
98 105535 RK	R-5	Rural-5 Acre	Single Family Res-Combo
98 107814 RK	R-5	Rural-5 Acre	Single Family Res-Combo
98 107213 MH	R-5	Rural-5 Acre	Double Wide
98 104468 RK	R-5	Rural-5 Acre	Single Family Res-Combo
97 111723 RK	R-5	Rural-5 Acre	Single Family Res-Combo
97 111946 RK	R-5	Rural-5 Acre	Single Family Res-Combo
98 100333 RK	R-5	Rural-5 Acre	SFR-Basic
98 109552 RK	R-5	Rural-5 Acre	Single Family Res-Combo
98 100368 RK	CITY	City	Duplex-Combo
98 100594 MH	R-5	Rural-5 Acre	Double Wide
98 105012 RK	R-5	Rural-5 Acre	Single Family Res-Combo
98 103223 MH	R-5	Rural-5 Acre	Triple Wide
97 104348 RK	F	Forestry	Single Family Res-Combo
98 104419 RK	R-5	Rural-5 Acre	Single Family Res-Combo
95 108334 000 01 MH	R-5	Rural-5 Acre	Single Wide
97 111775 RK	R-5	Rural-5 Acre	Single Family Res-Combo
96 106541 000 01 RK	R-5	Rural-5 Acre	Single Family Res-Combo
98 103170 RK	RRT-10	Rural Resource Transition-10	Single Family Res-Combo
98 107202 RK	RD	Rural Diversification	Single Family Res-Combo
98 108322 MH	R-5	Rural-5 Acre	Triple Wide
96 104123 000 01 MH	F	Forestry	Single Wide
96 106842 RK	R-5	Rural-5 Acre	Single Family Res-Combo
96 110568 MH	A-10	Agriculture-10 Acre	Double Wide
97 110654 RK	R-9,600	Residential 9,600 sq. ft.	Single Family Res-Combo
98 104659 RK	R-5	Rural-5 Acre	Single Family Res-Combo
98 108738 MH	R-5	Rural-5 Acre	
98 107230 RK	R-5	Rural-5 Acre	Single Family Res-Combo
98 104909 RK	R-5	Rural-5 Acre	Single Family Res-Combo
98 107665 RK	R-5	Rural-5 Acre	Single Family Res-Combo
98 106157 RK	R-5	Rural-5 Acre	Single Family Res-Combo
98 106154 RK	R-5	Rural-5 Acre	Single Family Res-Combo
98 109198 RK	R-5	Rural-5 Acre	Single Family Res-Combo
97 102933 RK	R-5	Rural-5 Acre	Single Family Res-Combo
98 105541 RK	R-5	Rural-5 Acre	Single Family Res-Combo
98 107227 MH	R-5	Rural-5 Acre	Single Wide
98 103162 RK	R-5	Rural-5 Acre	Single Family Res-Combo
98 103226 RK	R-5	Rural-5 Acre	Single Family Res-Combo
95 107863 000 01 RK	R-5	Rural-5 Acre	Single Family Res-Combo

Accessory Dwelling Units

Index # - File Name: 1.0022 - Single Family Dwellings Data\_Snohomish County.pdf

97 110139 RK	R-5	Rural-5 Acre	Single Family Res-Combo
98 104109 RK	R-5	Rural-5 Acre	Single Family Res-Combo
98 105727 RK	R-5	Rural-5 Acre	SFR-Basic
98 105728 RK	R-5	Rural-5 Acre	SFR-Basic
95 106332 000 01 RK	R-9,600	Residential 9,600 sq. ft.	Single Family Res-Combo
97 111759 RK	RD	Rural Diversification	Single Family Res-Combo
98 106619 RK	A-10	Agriculture-10 Acre	Single Family Res-Combo
98 108002 MH	R-5	Rural-5 Acre	Double Wide
97 111593 RK	R-5	Rural-5 Acre	Single Family Res-Combo
97 111595 RK	R-5	Rural-5 Acre	Single Family Res-Combo
97 111596 RK	R-5	Rural-5 Acre	Single Family Res-Combo
97 109885 RK	R-5	Rural-5 Acre	SFR-Basic
98 108347 RK	R-5	Rural-5 Acre	Single Family Res-Combo
98 101754 RK	R-5	Rural-5 Acre	SFR-Basic
98 104044 RK	R-5	Rural-5 Acre	Single Family Res-Combo
98 100152 RK	PRD-LDMR	Low Density Multiple Reside	SFR-Basic
98 100153 RK	PRD-LDMR	Low Density Multiple Reside	SFR-Basic
98 100154 RK	PRD-LDMR	Low Density Multiple Reside	SFR-Basic
98 100155 RK	PRD-LDMR	Low Density Multiple Reside	SFR-Basic
98 100144 RK	PRD-LDMR	Low Density Multiple Reside	SFR-Basic
98 100145 RK	PRD-LDMR	Low Density Multiple Reside	SFR-Basic
98 100146 RK	PRD-LDMR	Low Density Multiple Reside	SFR-Basic
98 100147 RK	PRD-LDMR	Low Density Multiple Reside	SFR-Basic
98 100364 RK	PRD-LDMR	Low Density Multiple Reside	SFR-Basic
98 100365 RK	PRD-LDMR	Low Density Multiple Reside	SFR-Basic
98 100366 RK	PRD-LDMR	Low Density Multiple Reside	SFR-Basic
98 100367 RK	PRD-LDMR	Low Density Multiple Reside	SFR-Basic
98 100356 RK	PRD-LDMR	Low Density Multiple Reside	SFR-Basic
98 100357 RK	PRD-LDMR	Low Density Multiple Reside	SFR-Basic
98 100358 RK	PRD-LDMR	Low Density Multiple Reside	SFR-Basic
98 100359 RK	PRD-LDMR	Low Density Multiple Reside	SFR-Basic
98 100360 RK	PRD-LDMR	Low Density Multiple Reside	SFR-Basic
98 100361 RK	PRD-LDMR	Low Density Multiple Reside	SFR-Basic
98 100362 RK	PRD-LDMR	Low Density Multiple Reside	SFR-Basic
98 100363 RK	PRD-LDMR	Low Density Multiple Reside	SFR-Basic
98 100148 RK	PRD-LDMR	Low Density Multiple Reside	SFR-Basic
98 100149 RK	PRD-LDMR	Low Density Multiple Reside	SFR-Basic
98 100150 RK	PRD-LDMR	Low Density Multiple Reside	SFR-Basic
98 100151 RK	PRD-LDMR	Low Density Multiple Reside	SFR-Basic
98 104380 RK	R-5	Rural-5 Acre	Single Family Res-Combo
98 100735 RK	R-5	Rural-5 Acre	Single Family Res-Combo
97 103644 RK	R-5	Rural-5 Acre	Single Family Res-Combo
97 109236 MH	RD	Rural Diversification	Double Wide
98 108014 RK	R-5	Rural-5 Acre	Single Family Res-Combo
98 103546 RK	CITY	City	Single Family Res-Combo
97 111614 MH	R-5	Rural-5 Acre	Double Wide
98 101929 MH	R-5	Rural-5 Acre	Double Wide

Accessory Dwelling Units

Index # - File Name: 1.0022 - Single Family Dwellings Data\_Snohomish County.pdf

98 103689 MH	R-5	Rural-5 Acre	Triple Wide
98 107003 RK	R-5	Rural-5 Acre	Single Family Res-Combo
98 104878 RK	PRD-9,600	Residential 9,600 sq. ft.	Single Family Res-Combo
98 104881 RK	PRD-9,600	Residential 9,600 sq. ft.	Single Family Res-Combo
97 108009 RK	R-5	Rural-5 Acre	Single Family Res-Combo
98 105474 RK	CITY	City	Single Family Res-Combo
98 100370 RK	CITY	City	Single Family Res-Combo
97 108688 MH	R-5	Rural-5 Acre	Double Wide
97 111349 RK	R-5	Rural-5 Acre	Single Family Res-Combo
98 104396 RK	CITY	City	Duplex-Combo
98 104988 RK	R-5	Rural-5 Acre	Single Family Res-Combo
98 100438 MH	A-10	Agriculture-10 Acre	Single Wide
97 111172 RK	R-5	Rural-5 Acre	Single Family Res-Combo
98 101755 RK	R-9,600	Residential 9,600 sq. ft.	Single Family Res-Combo
95 105066 000 01 RK	RD	Rural Diversification	Single Family Res-Combo
98 109942 RK	R-5	Rural-5 Acre	Single Family Res-Combo
98 110382 MH	R-5	Rural-5 Acre	Double Wide
98 100170 RK	R-5	Rural-5 Acre	Single Family Res-Combo
97 111156 RK	R-5	Rural-5 Acre	Single Family Res-Combo
97 111729 RK	R-5	Rural-5 Acre	Single Family Res-Combo
98 100042 RK	R-5	Rural-5 Acre	Single Family Res-Combo
98 107191 RK	R-5	Rural-5 Acre	Single Family Res-Combo
98 107193 RK	R-5	Rural-5 Acre	Single Family Res-Combo
98 105653 RK	R-5	Rural-5 Acre	Single Family Res-Combo
98 102660 RK	R-5	Rural-5 Acre	Single Family Res-Combo
98 106598 RK	R-5	Rural-5 Acre	Single Family Res-Combo
98 104924 RK	R-9,600	Residential 9,600 sq. ft.	SFR-Basic
98 103881 RK	R-9,600	Residential 9,600 sq. ft.	Single Family Res-Combo
98 105421 RK	R-9,600	Residential 9,600 sq. ft.	SFR-Basic
98 103303 RK	R-9,600	Residential 9,600 sq. ft.	Single Family Res-Combo
98 101989 RK	R-9,600	Residential 9,600 sq. ft.	Single Family Res-Combo
98 105417 RK	R-9,600	Residential 9,600 sq. ft.	SFR-Basic
98 102267 RK	R-9,600	Residential 9,600 sq. ft.	Single Family Res-Combo
98 101472 RK	R-9,600	Residential 9,600 sq. ft.	Single Family Res-Combo
97 111403 RK	R-9,600	Residential 9,600 sq. ft.	Single Family Res-Combo
97 111404 RK	R-9,600	Residential 9,600 sq. ft.	Single Family Res-Combo
98 109364 RK	R-5	Rural-5 Acre	Single Family Res-Combo
98 106964 RK	R-5	Rural-5 Acre	Single Family Res-Combo
98 106220 RK	R-5	Rural-5 Acre	Single Family Res-Combo
97 111854 RK	R-5	Rural-5 Acre	Single Family Res-Combo
98 103132 RK	R-5	Rural-5 Acre	Single Family Res-Combo
98 104814 RK	R-5	Rural-5 Acre	Single Family Res-Combo
98 110304 RK	R-5	Rural-5 Acre	Single Family Res-Combo
96 106282 000 01 MH	RC	Rural Conservation	Single Wide
98 107765 RK	R-5	Rural-5 Acre	Single Family Res-Combo
98 100953 MH	RC	Rural Conservation	Double Wide
98 106494 RK	R-5	Rural-5 Acre	Single Family Res-Combo

Accessory Dwelling Units

Index # - File Name: 1.0022 - Single Family Dwellings Data\_Snohomish County.pdf

97 111857 RK	R-5	Rural-5 Acre	Single Family Res-Combo
98 105465 RK	R-5	Rural-5 Acre	Duplex-Combo
98 104100 MH	R-5	Rural-5 Acre	Double Wide
98 106801 MH	R-5	Rural-5 Acre	Single Wide
98 106649 MH	A-10	Agriculture-10 Acre	Double Wide
98 109857 MH	R-5	Rural-5 Acre	Double Wide
97 105796 RK	R-5	Rural-5 Acre	Single Family Res-Combo
97 105804 RK	R-5	Rural-5 Acre	Single Family Res-Combo
98 107841 RK	R-5	Rural-5 Acre	Single Family Res-Combo
98 104699 RK	R-5	Rural-5 Acre	Single Family Res-Combo
98 100184 RK	R-5	Rural-5 Acre	Single Family Res-Combo
97 106751 RK	F	Forestry	Single Family Res-Combo
98 109521 RK	RRT-10	Rural Resource Transition-10	Single Family Res-Combo
98 106759 MH	RRT-10	Rural Resource Transition-10	Triple Wide
98 104918 RK	R-9,600	Residential 9,600 sq. ft.	Single Family Res-Combo
97 109230 RK	R-8,400	Residential 8,400 sq. ft.	Single Family Res-Combo
98 100654 RK	R-8,400	Residential 8,400 sq. ft.	SFR-Basic
98 100653 RK	R-8,400	Residential 8,400 sq. ft.	SFR-Basic
98 103897 RK	R-9,600	Residential 9,600 sq. ft.	Single Family Res-Combo
98 104450 RK	R-9,600	Residential 9,600 sq. ft.	Single Family Res-Combo
98 102788 RK	R-9,600	Residential 9,600 sq. ft.	SFR-Basic
98 106538 RK	R-9,600	Residential 9,600 sq. ft.	Single Family Res-Combo
98 105949 RK	R-9,600	Residential 9,600 sq. ft.	Single Family Res-Combo
98 102774 RK	R-9,600	Residential 9,600 sq. ft.	Single Family Res-Combo
98 102776 RK	R-9,600	Residential 9,600 sq. ft.	Single Family Res-Combo
98 103450 RK	R-9,600	Residential 9,600 sq. ft.	Single Family Res-Combo
98 100655 RK	R-8,400	Residential 8,400 sq. ft.	SFR-Basic
98 109449 RK	R-8,400	Residential 8,400 sq. ft.	Single Family Res-Combo
98 100618 RK	R-8,400	Residential 8,400 sq. ft.	Single Family Res-Combo
98 109450 RK	R-8,400	Residential 8,400 sq. ft.	Single Family Res-Combo
97 110324 RK	R-8,400	Residential 8,400 sq. ft.	SFR-Basic
98 100651 RK	R-8,400	Residential 8,400 sq. ft.	SFR-Basic
97 108342 RK	R-8,400	Residential 8,400 sq. ft.	Single Family Res-Combo
98 106496 RK	R-8,400 : R-9,600	Residential 8,400 sq. ft. : Residential 9,600 sq. ft.	Single Family Res-Combo
98 109444 RK	R-8,400	Residential 8,400 sq. ft.	Single Family Res-Combo
98 109447 RK	R-8,400	Residential 8,400 sq. ft.	Single Family Res-Combo
97 111546 RK	R-8,400	Residential 8,400 sq. ft.	Single Family Res-Combo
98 106144 RK	R-8,400	Residential 8,400 sq. ft.	SFR-Basic
98 109451 RK	R-8,400	Residential 8,400 sq. ft.	Single Family Res-Combo
97 111547 RK	R-9,600	Residential 9,600 sq. ft.	Single Family Res-Combo
98 109257 RK	R-8,400	Residential 8,400 sq. ft.	Single Family Res-Combo
98 109924 RK	R-8,400	Residential 8,400 sq. ft.	Single Family Res-Combo
98 102930 RK	R-5	Rural-5 Acre	Single Family Res-Combo
97 108520 MH	R-5	Rural-5 Acre	Double Wide
98 107666 RK	R-5	Rural-5 Acre	Single Family Res-Combo
98 100742 RK	R-5	Rural-5 Acre	Single Family Res-Combo
97 111450 RK	R-5	Rural-5 Acre	Single Family Res-Combo



Accessory Dwelling Units

Index # - File Name: 1.0022 - Single Family Dwellings Data\_Snohomish County.pdf

98 106493 RK	R-9,600	Residential 9,600 sq. ft.	SFR-Basic
96 106419 MH	A-10	Agriculture-10 Acre	Double Wide
98 106539 RK	R-9,600	Residential 9,600 sq. ft.	Single Family Res-Combo
98 105155 RK	R-9,600	Residential 9,600 sq. ft.	Single Family Res-Combo
98 104443 RK	R-7,200 : R-9,600	Residential 7,200 sq. ft. : Residential 9,600 sq. ft.	SFR-Basic
98 104444 RK	R-9,600	Residential 9,600 sq. ft.	SFR-Basic
98 100554 RK	RRT-10	Rural Resource Transition-10	Single Family Res-Combo
98 100552 RK	RRT-10	Rural Resource Transition-10	SFR-Basic
97 105798 RK	R-5	Rural-5 Acre	Single Family Res-Combo
97 111253 RK	R-5	Rural-5 Acre	Single Family Res-Combo
98 116990 MH	R-5	Rural-5 Acre	Double Wide
98 101787 RK	WFB	Waterfront Beach	Single Family Res-Combo
98 104579 MH	R-5	Rural-5 Acre	Single Wide
98 103001 RK	R-5	Rural-5 Acre	Single Family Res-Combo
98 105928 RK	R-5	Rural-5 Acre	SFR-Basic
98 109103 RK	R-5	Rural-5 Acre	Single Family Res-Combo
98 100691 MH	R-5	Rural-5 Acre	Double Wide
98 104820 MH	RRT-10	Rural Resource Transition-10	Double Wide
98 106237 RK	R-5	Rural-5 Acre	Single Family Res-Combo
98 102348 RK	R-5	Rural-5 Acre	SFR-Basic
96 109559 RK	R-5	Rural-5 Acre	Single Family Res-Combo
98 105532 RK	R-5	Rural-5 Acre	Single Family Res-Combo
97 108184 RK	R-5	Rural-5 Acre	Single Family Res-Combo
98 107062 MH	R-5	Rural-5 Acre	Triple Wide
97 111780 RK	PRD-9,600	Residential 9,600 sq. ft.	Single Family Res-Combo
97 111781 RK	PRD-9,600	Residential 9,600 sq. ft.	Single Family Res-Combo
98 105952 RK	R-5	Rural-5 Acre	Single Family Res-Combo
98 106974 RK	R-5	Rural-5 Acre	Single Family Res-Combo
96 101038 RK	R-5	Rural-5 Acre	Single Family Res-Combo
98 108452 RK	R-9,600	Residential 9,600 sq. ft.	Single Family Res-Combo
98 105965 RK	R-5	Rural-5 Acre	Single Family Res-Combo
98 105416 RK	R-9,600	Residential 9,600 sq. ft.	SFR-Basic
98 103884 RK	R-9,600	Residential 9,600 sq. ft.	Single Family Res-Combo
98 102269 RK	R-9,600	Residential 9,600 sq. ft.	Single Family Res-Combo
98 104260 RK	R-9,600	Residential 9,600 sq. ft.	Single Family Res-Combo
98 105419 RK	R-9,600	Residential 9,600 sq. ft.	SFR-Basic
98 101991 RK	R-9,600	Residential 9,600 sq. ft.	Single Family Res-Combo
98 101470 RK	R-9,600	Residential 9,600 sq. ft.	Single Family Res-Combo
98 103040 RK	R-9,600	Residential 9,600 sq. ft.	SFR-Basic
98 101988 RK	R-9,600	Residential 9,600 sq. ft.	SFR-Basic
98 105069 RK	CITY	City	Single Family Res-Combo
97 110624 RK	CITY	City	Single Family Res-Combo
97 107964 RK	CITY	City	Single Family Res-Combo
98 104015 RK	R-5	Rural-5 Acre	Single Family Res-Combo
98 104897 RK	R-5	Rural-5 Acre	Single Family Res-Combo
98 102094 RK	R-5	Rural-5 Acre	Single Family Res-Combo
98 102090 RK	R-5	Rural-5 Acre	Single Family Res-Combo

Accessory Dwelling Units

Index # - File Name: 1.0022 - Single Family Dwellings Data\_Snohomish County.pdf

98 100382 RK	R-5	Rural-5 Acre	Single Family Res-Combo
98 101903 RK	R-5	Rural-5 Acre	Single Family Res-Combo
98 100377 RK	R-5	Rural-5 Acre	Single Family Res-Combo
98 102812 RK	PRD-20,000	Residential 20,000 sq. ft.	Single Family Res-Combo
98 103387 RK	R-5	Rural-5 Acre	Single Family Res-Combo
98 100020 RK	R-5	Rural-5 Acre	Single Family Res-Combo
97 105809 RK	R-5	Rural-5 Acre	SFR-Basic
97 111112 RK	CITY	City	Duplex-Combo
97 106410 RK	R-5	Rural-5 Acre	Single Family Res-Combo
98 101427 RK	PRD-9,600	Residential 9,600 sq. ft.	SFR-Basic
98 101430 RK	PRD-9,600	Residential 9,600 sq. ft.	SFR-Basic
98 101434 RK	PRD-9,600	Residential 9,600 sq. ft.	SFR-Basic
98 101435 RK	PRD-9,600	Residential 9,600 sq. ft.	SFR-Basic
98 101437 RK	PRD-9,600	Residential 9,600 sq. ft.	SFR-Basic
98 101439 RK	PRD-9,600	Residential 9,600 sq. ft.	SFR-Basic
98 103774 RK	PRD-9,600	Residential 9,600 sq. ft.	SFR-Basic
98 103776 RK	PRD-9,600	Residential 9,600 sq. ft.	SFR-Basic
98 103273 RK	R-5	Rural-5 Acre	Single Family Res-Combo
98 105742 RK	R-7,200	Residential 7,200 sq. ft.	Single Family Res-Combo
97 111897 RK	R-5	Rural-5 Acre	Single Family Res-Combo
98 101975 RK	R-5	Rural-5 Acre	SFR-Basic
98 102789 RK	R-5	Rural-5 Acre	SFR-Basic
98 100212 RK	R-5	Rural-5 Acre	Single Family Res-Combo
98 100283 RK	R-5	Rural-5 Acre	Single Family Res-Combo
98 100269 RK	R-5	Rural-5 Acre	Single Family Res-Combo
98 100266 RK	R-5	Rural-5 Acre	Single Family Res-Combo
97 111701 RK	CITY	City	SFR-Basic
97 111702 RK	CITY	City	SFR-Basic
97 111703 RK	CITY	City	SFR-Basic
97 111704 RK	CITY	City	SFR-Basic
97 111705 RK	CITY	City	SFR-Basic
97 111706 RK	CITY	City	SFR-Basic
98 101144 RK	R-5	Rural-5 Acre	Single Family Res-Combo
98 100166 RK	R-20,000	Residential 20,000 sq. ft.	SFR-Basic
98 100159 RK	R-20,000	Residential 20,000 sq. ft.	SFR-Basic
98 100157 RK	R-20,000	Residential 20,000 sq. ft.	SFR-Basic
98 100164 RK	R-20,000	Residential 20,000 sq. ft.	SFR-Basic
98 100162 RK	R-20,000	Residential 20,000 sq. ft.	SFR-Basic
98 100163 RK	R-20,000	Residential 20,000 sq. ft.	SFR-Basic
98 100165 RK	R-20,000	Residential 20,000 sq. ft.	SFR-Basic
98 100160 RK	R-20,000	Residential 20,000 sq. ft.	SFR-Basic
98 100161 RK	R-20,000	Residential 20,000 sq. ft.	SFR-Basic
98 102767 RK	R-20,000	Residential 20,000 sq. ft.	SFR-Basic
98 102708 RK	R-20,000	Residential 20,000 sq. ft.	SFR-Basic
97 111524 RK	R-20,000	Residential 20,000 sq. ft.	SFR-Basic
97 111785 RK	R-20,000	Residential 20,000 sq. ft.	SFR-Basic
98 102710 RK	R-20,000	Residential 20,000 sq. ft.	Single Family Res-Combo

Accessory Dwelling Units

Index # - File Name: 1.0022 - Single Family Dwellings Data\_Snohomish County.pdf

98 102707 RK	R-20,000	Residential 20,000 sq. ft.	SFR-Basic
98 101572 RK	R-20,000	Residential 20,000 sq. ft.	Single Family Res-Combo
98 103979 MH	R-5	Rural-5 Acre	Triple Wide
97 110552 MH	R-5	Rural-5 Acre	Double Wide
98 101907 RK	R-5	Rural-5 Acre	Single Family Res-Combo
97 108774 RK	R-5	Rural-5 Acre	Single Family Res-Combo
97 110739 RK	R-5	Rural-5 Acre	Single Family Res-Combo
98 100546 RK	CITY	City	Single Family Res-Combo
98 102053 RK	R-5	Rural-5 Acre	Single Family Res-Combo
98 102636 RK	CITY	City	SFR-Basic
98 102632 RK	CITY	City	SFR-Basic
98 100927 RK	CITY	City	SFR-Basic
98 100932 RK	CITY	City	SFR-Basic
98 103505 RK	CITY	City	SFR-Basic
98 103506 RK	CITY	City	SFR-Basic
98 116952 RK	CITY	City	SFR-Basic
98 116954 RK	CITY	City	SFR-Basic
98 116955 RK	CITY	City	SFR-Basic
98 116956 RK	CITY	City	SFR-Basic
98 106504 RK	CITY	City	SFR-Basic
98 106505 RK	CITY	City	SFR-Basic
98 106506 RK	CITY	City	SFR-Basic
98 108393 RK	CITY	City	Single Family Res-Combo
98 106507 RK	CITY	City	SFR-Basic
98 108395 RK	CITY	City	Single Family Res-Combo
98 106501 RK	CITY	City	SFR-Basic
98 106503 RK	CITY	City	SFR-Basic
98 108394 RK	CITY	City	Single Family Res-Combo
97 109999 MH	R-5	Rural-5 Acre	Triple Wide
98 102905 RK	R-5	Rural-5 Acre	SFR-Basic
98 100130 RK	CITY	City	Single Family Res-Combo
98 100128 RK	CITY	City	SFR-Basic
98 100126 RK	CITY	City	SFR-Basic
98 116945 RK	CITY	City	SFR-Basic
98 106499 RK	CITY	City	SFR-Basic
98 105921 RK	CITY	City	SFR-Basic
98 100125 RK	CITY	City	SFR-Basic
98 105922 RK	CITY	City	SFR-Basic
98 105923 RK	CITY	City	SFR-Basic
98 100928 RK	CITY	City	SFR-Basic
98 100931 RK	CITY	City	SFR-Basic
98 106500 RK	CITY	City	SFR-Basic
98 105924 RK	CITY	City	SFR-Basic
98 105926 RK	CITY	City	SFR-Basic
98 107007 RK	CITY	City	Single Family Res-Combo
98 116947 RK	CITY	City	SFR-Basic
98 116949 RK	CITY	City	SFR-Basic

Accessory Dwelling Units

Index # - File Name: 1.0022 - Single Family Dwellings Data\_Snohomish County.pdf

98 116950 RK	CITY	City	SFR-Basic
98 116951 RK	CITY	City	SFR-Basic
98 103510 RK	CITY	City	SFR-Basic
98 103507 RK	CITY	City	SFR-Basic
98 105439 RK	CITY	City	SFR-Basic
98 105438 RK	CITY	City	SFR-Basic
98 105437 RK	CITY	City	SFR-Basic
98 105433 RK	CITY	City	SFR-Basic
98 104913 RK	CITY	City	SFR-Basic
98 104922 RK	CITY	City	SFR-Basic
98 102681 RK	R-5	Rural-5 Acre	Single Family Res-Combo
98 102907 RK	R-5	Rural-5 Acre	SFR-Basic
97 101995 RK	R-5	Rural-5 Acre	Single Family Res-Combo
98 106130 RK	CITY	City	Single Family Res-Combo
97 101609 RK	R-5	Rural-5 Acre	Single Family Res-Combo
98 102829 RK	R-5	Rural-5 Acre	Single Family Res-Combo
98 106704 RK	R-5	Rural-5 Acre	Single Family Res-Combo
98 103326 RK	R-5	Rural-5 Acre	Single Family Res-Combo
98 103893 RK	RRT-10	Rural Resource Transition-10	Duplex-Combo
97 111551 RK	R-5	Rural-5 Acre	SFR-Basic
98 101146 RK	R-5	Rural-5 Acre	Single Family Res-Combo
97 101735 MH	F	Forestry	Triple Wide
98 108111 MH	R-5	Rural-5 Acre	Double Wide
97 110613 RK	R-5	Rural-5 Acre	Single Family Res-Combo
98 104189 RK	R-5	Rural-5 Acre	Single Family Res-Combo
98 101063 RK	R-5	Rural-5 Acre	Single Family Res-Combo
98 102969 MH	R-5	Rural-5 Acre	Double Wide
98 100660 RK	R-5	Rural-5 Acre	SFR-Basic
97 111957 RK	R-5	Rural-5 Acre	SFR-Basic
98 100656 MH	R-12,500	Residential 12,500 sq. ft.	Single Wide
98 101699 RK	R-5	Rural-5 Acre	Single Family Res-Combo
98 103525 RK	R-5	Rural-5 Acre	SFR-Basic
98 101965 RK	R-5	Rural-5 Acre	Single Family Res-Combo
98 103517 RK	R-5	Rural-5 Acre	Single Family Res-Combo
98 105078 RK	R-5	Rural-5 Acre	Single Family Res-Combo
98 102484 RK	R-5	Rural-5 Acre	Single Family Res-Combo
98 108476 RK	R-5	Rural-5 Acre	Single Family Res-Combo
97 108461 MH	R-5	Rural-5 Acre	Single Wide
98 100761 RK	R-5	Rural-5 Acre	SFR-Basic
98 100762 RK	R-5	Rural-5 Acre	SFR-Basic
98 100765 RK	R-5	Rural-5 Acre	SFR-Basic
98 102007 RK	R-5	Rural-5 Acre	Single Family Res-Combo
98 104000 RK	F	Forestry	Single Family Res-Combo
98 102247 RK	R-5	Rural-5 Acre	SFR-Basic
98 100767 RK	R-5	Rural-5 Acre	Single Family Res-Combo
98 102250 RK	R-5	Rural-5 Acre	SFR-Basic
98 106183 RK	R-5	Rural-5 Acre	Single Family Res-Combo

Accessory Dwelling Units

Index # - File Name: 1.0022 - Single Family Dwellings Data\_Snohomish County.pdf

98 100395 RK	R-5	Rural-5 Acre	SFR-Basic
98 106443 RK	R-5	Rural-5 Acre	Single Family Res-Combo
98 103578 RK	R-5	Rural-5 Acre	SFR-Basic
98 110215 RK	R-9,600	Residential 9,600 sq. ft.	Duplex-Basic
98 102862 RK	R-5	Rural-5 Acre	Single Family Res-Combo
98 103244 RK	F	Forestry	Single Family Res-Combo
98 100422 MH	R-5	Rural-5 Acre	Double Wide
98 100887 RK	R-5	Rural-5 Acre	Single Family Res-Combo
98 107854 RK	R-5	Rural-5 Acre	Single Family Res-Combo
98 101291 RK	R-5	Rural-5 Acre	Single Family Res-Combo
98 106626 RK	R-5	Rural-5 Acre	Single Family Res-Combo
98 104499 RK	R-5	Rural-5 Acre	Single Family Res-Combo
97 111108 RK	R-5	Rural-5 Acre	Single Family Res-Combo
98 100371 RK	R-5	Rural-5 Acre	Single Family Res-Combo
98 106185 RK	R-5	Rural-5 Acre	Single Family Res-Combo
97 110129 RK	R-5	Rural-5 Acre	Single Family Res-Combo
98 104787 RK	R-5	Rural-5 Acre	Single Family Res-Combo
98 103997 RK	R-5	Rural-5 Acre	Single Family Res-Combo
96 104156 000 01 MH	NB	Neighborhood Business	MH Park-Double Wide
98 104470 RK	R-5	Rural-5 Acre	SFR-Basic
98 103535 RK	R-5	Rural-5 Acre	SFR-Basic
98 100612 RK	R-5	Rural-5 Acre	Single Family Res-Combo
96 106629 RK	R-5	Rural-5 Acre	Single Family Res-Combo
98 106022 RK	MR	Multiple Residential	Duplex-Basic
98 106026 RK	MR	Multiple Residential	Duplex-Basic
98 106036 RK	MR	Multiple Residential	Duplex-Basic
98 106028 RK	MR	Multiple Residential	Duplex-Basic
98 106029 RK	MR	Multiple Residential	Duplex-Basic
98 106031 RK	MR	Multiple Residential	Duplex-Basic
98 106032 RK	MR	Multiple Residential	Duplex-Basic
98 104893 RK	MR	Multiple Residential	Duplex-Basic
98 104896 RK	MR	Multiple Residential	Duplex-Basic
98 106033 RK	MR	Multiple Residential	Duplex-Basic
98 106034 RK	MR	Multiple Residential	Duplex-Basic
98 106035 RK	MR	Multiple Residential	Duplex-Basic
97 102657 MH	A-10	Agriculture-10 Acre	Double Wide
96 110189 MH	R-5	Rural-5 Acre	Double Wide
98 103695 RK	R-9,600	Residential 9,600 sq. ft.	Single Family Res-Combo
98 109080 RK	SA-1	Suburban Agriculture-1 Acre	SFR-Basic
97 111400 RK	R-5	Rural-5 Acre	Single Family Res-Combo
98 104733 RK	R-5	Rural-5 Acre	Single Family Res-Combo
98 102141 MH	R-5	Rural-5 Acre	Double Wide
98 105930 RK	R-5	Rural-5 Acre	Single Family Res-Combo
98 106447 RK	CITY	City	Single Family Res-Combo
98 103030 RK	R-5	Rural-5 Acre	Single Family Res-Combo
98 104817 RK	R-5	Rural-5 Acre	Single Family Res-Combo
98 105516 RK	R-5	Rural-5 Acre	Single Family Res-Combo

Accessory Dwelling Units

Index # - File Name: 1.0022 - Single Family Dwellings Data\_Snohomish County.pdf

97 110299 RK	A-10	Agriculture-10 Acre	Duplex-Combo
98 106174 RK	R-5	Rural-5 Acre	Single Family Res-Combo
98 106708 RK	R-5	Rural-5 Acre	Single Family Res-Combo
98 100634 RK	R-8,400	Residential 8,400 sq. ft.	SFR-Basic
98 107184 RK	R-5	Rural-5 Acre	Single Family Res-Combo
98 101011 RK	R-5	Rural-5 Acre	Single Family Res-Combo
98 102455 RK	R-5	Rural-5 Acre	Single Family Res-Combo
98 100482 RK	R-5	Rural-5 Acre	Single Family Res-Combo
98 100485 RK	R-5	Rural-5 Acre	Single Family Res-Combo
98 103092 RK	R-5	Rural-5 Acre	Single Family Res-Combo
96 100681 000 01 MH	SA-1	Suburban Agriculture-1 Acre	Double Wide
98 101332 RK	R-5	Rural-5 Acre	Single Family Res-Combo
98 103182 RK	R-5	Rural-5 Acre	Single Family Res-Combo
98 107135 RK	R-5	Rural-5 Acre	Single Family Res-Combo
97 111416 RK	R-5	Rural-5 Acre	Single Family Res-Combo
98 103824 MH	MHP	Mobile Home Park	MH Park-Double Wide
98 104813 RK	R-5	Rural-5 Acre	Single Family Res-Combo
98 103398 RK	R-5	Rural-5 Acre	Single Family Res-Combo
97 106506 RK	R-5	Rural-5 Acre	Single Family Res-Combo
98 100955 RK	RRT-10	Rural Resource Transition-10	SFR-Basic
97 111712 000 01 RK	PRD-9,600	Residential 9,600 sq. ft.	Single Family Res-Combo
98 106510 MH	R-5	Rural-5 Acre	Double Wide
98 110205 RK	R-5	Rural-5 Acre	Single Family Res-Combo
98 110202 RK	R-5	Rural-5 Acre	Single Family Res-Combo
98 106163 RK	R-5	Rural-5 Acre	Single Family Res-Combo
98 106064 RK	R-5	Rural-5 Acre	Single Family Res-Combo
98 103027 RK	R-5	Rural-5 Acre	SFR-Basic
97 110314 RK	R-5	Rural-5 Acre	Single Family Res-Combo
98 107711 RK	RRT-10	Rural Resource Transition-10	Single Family Res-Combo
98 100404 RK	R-5	Rural-5 Acre	Single Family Res-Combo
97 111511 RK	RRT-10	Rural Resource Transition-10	Single Family Res-Combo
98 104677 RK	RRT-10	Rural Resource Transition-10	Single Family Res-Combo
98 103409 RK	RRT-10	Rural Resource Transition-10	Single Family Res-Combo
98 109015 RK	RRT-10	Rural Resource Transition-10	Single Family Res-Combo
97 110849 RK	R-5	Rural-5 Acre	Single Family Res-Combo
98 108951 RK	R-5	Rural-5 Acre	Single Family Res-Combo
98 106529 RK	R-5	Rural-5 Acre	Single Family Res-Combo
98 108776 RK	R-7,200	Residential 7,200 sq. ft.	Single Family Res-Combo
96 109815 MH	F	Forestry	Single Wide
96 103576 000 01 RK	R-5	Rural-5 Acre	Single Family Res-Combo
97 111397 RK	R-5	Rural-5 Acre	Single Family Res-Combo
98 105723 RK	R-5	Rural-5 Acre	Single Family Res-Combo
98 100228 RK	R-5	Rural-5 Acre	Single Family Res-Combo
98 107946 RK	R-5	Rural-5 Acre	Single Family Res-Combo
98 108781 MH	R-5	Rural-5 Acre	Double Wide
96 102616 MH	R-5	Rural-5 Acre	Double Wide
96 102909 MH	F	Forestry	Double Wide

Accessory Dwelling Units

Index # - File Name: 1.0022 - Single Family Dwellings Data\_Snohomish County.pdf

98 107027 MH	R-5	Rural-5 Acre	Double Wide
98 104403 RK	R-5	Rural-5 Acre	Single Family Res-Combo
98 109720 RK	PRD-LDMR	Low Density Multiple Reside	Single Family Res-Combo
98 104251 RK	F	Forestry	Single Family Res-Combo
97 111716 RK	PRD-9,600	Residential 9,600 sq. ft.	Single Family Res-Combo
97 111399 RK	PRD-LDMR	Low Density Multiple Reside	Single Family Res-Combo
97 111001 RK	PRD-LDMR	Low Density Multiple Reside	Single Family Res-Combo
98 101860 RK	PRD-LDMR	Low Density Multiple Reside	Single Family Res-Combo
98 101042 RK	PRD-LDMR	Low Density Multiple Reside	Single Family Res-Combo
98 107669 RK	PRD-20,000	Residential 20,000 sq. ft.	Single Family Res-Combo
98 100194 RK	R-7,200	Residential 7,200 sq. ft.	Single Family Res-Combo
98 106283 MH	R-5	Rural-5 Acre	Double Wide
98 105803 RK	R-5	Rural-5 Acre	Single Family Res-Combo
98 101889 RK	R-5	Rural-5 Acre	Single Family Res-Combo
98 106687 MH	CITY	City	MH Park-Triple Wide
98 100406 RK	CITY	City	Duplex-Combo
98 105344 RK	R-5	Rural-5 Acre	Single Family Res-Combo
97 111900 RK	R-5	Rural-5 Acre	Single Family Res-Combo
98 107016 RK	A-10	Agriculture-10 Acre	Single Family Res-Combo
98 103294 MH	CITY	City	Double Wide
98 105701 RK	R-5	Rural-5 Acre	Single Family Res-Combo
97 110477 RK	CITY	City	Single Family Res-Combo
96 105817 RK	UC	Urban Center	Single Family Res-Combo
98 108328 RK	R-7,200	Residential 7,200 sq. ft.	Duplex-Combo
98 103500 RK	R-5	Rural-5 Acre	Single Family Res-Combo
96 106622 RK	R-9,600	Residential 9,600 sq. ft.	Single Family Res-Combo
98 108628 MH	R-5	Rural-5 Acre	Double Wide
99 104078 RK	R-5	Rural-5 Acre	Single Family Res-Combo
99 105466 MH	R-5	Rural-5 Acre	Double Wide
98 108632 RK	R-5	Rural-5 Acre	Single Family Res-Combo
99 110649 MH	R-5	Rural-5 Acre	Double Wide
99 105382 MH	R-5	Rural-5 Acre	Double Wide
99 101593 RK	R-5	Rural-5 Acre	Single Family Res-Combo
99 110422 RK	R-9,600	Residential 9,600 sq. ft.	Single Family Res-Combo
99 102423 RK	R-5	Rural-5 Acre	Single Family Res-Combo
99 102561 RK	R-5	Rural-5 Acre	Single Family Res-Combo
99 103673 RK	R-5	Rural-5 Acre	Single Family Res-Combo
99 103794 RK	R-5	Rural-5 Acre	Single Family Res-Combo
99 113294 MH	CITY	City	MH Park-Double Wide
98 109694 RK	R-5	Rural-5 Acre	Single Family Res-Combo
99 113192 MH	R-5	Rural-5 Acre	Triple Wide
99 104390 RK	PRD-20,000	Residential 20,000 sq. ft.	Single Family Res-Combo
98 150910 RK	PRD-LDMR	Low Density Multiple Reside	Single Family Res-Combo
99 115256 RK	PRD-LDMR	Low Density Multiple Reside	Single Family Res-Combo
98 110174 RK	R-5	Rural-5 Acre	Single Family Res-Combo
99 102832 MH	A-10 : R-5	Agriculture-10 Acre : Rural-5	Single Wide
99 113460 RK	R-5	Rural-5 Acre	Single Family Res-Combo

Accessory Dwelling Units

Index # - File Name: 1.0022 - Single Family Dwellings Data\_Snohomish County.pdf

99 112610 RK	R-5	Rural-5 Acre	Single Family Res-Combo
96 107179 000 01 RK	R-5	Rural-5 Acre	Single Family Res-Combo
99 115409 MH	R-5	Rural-5 Acre	Double Wide
99 104749 RK	R-5	Rural-5 Acre	Single Family Res-Combo
99 101674 RK	R-5	Rural-5 Acre	Single Family Res-Combo
98 150892 RK	R-5	Rural-5 Acre	Single Family Res-Combo
99 111973 RK	F	Forestry	Single Family Res-Combo
99 101303 RK	R-5	Rural-5 Acre	SFR-Basic
99 101350 RK	R-5	Rural-5 Acre	SFR-Basic
99 100587 RK	F	Forestry	Single Family Res-Combo
99 109372 RK	CITY	City	Single Family Res-Combo
99 110425 RK	CITY	City	SFR-Basic
99 101692 MH	RRT-10	Rural Resource Transition-10	Triple Wide
99 110767 MH	R-5	Rural-5 Acre	Double Wide
98 109684 RK	R-5	Rural-5 Acre	Single Family Res-Combo
99 104908 RK	R-5	Rural-5 Acre	Single Family Res-Combo
98 150470 RK	PRD-9,600	Residential 9,600 sq. ft.	Single Family Res-Combo
98 150471 RK	PRD-9,600	Residential 9,600 sq. ft.	Single Family Res-Combo
99 114682 RK	R-5	Rural-5 Acre	Single Family Res-Combo
97 108507 000 01 RK	F	Forestry	Single Family Res-Combo
99 105434 RK	RC	Rural Conservation	Single Family Res-Combo
99 101998 RK	R-5	Rural-5 Acre	Single Family Res-Combo
99 109478 RK	R-5	Rural-5 Acre	Single Family Res-Combo
97 109661 RK	R-5	Rural-5 Acre	Single Family Res-Combo
99 101521 RK	R-5	Rural-5 Acre	Single Family Res-Combo
98 106037 RK	MR	Multiple Residential	Duplex-Basic
98 109401 MH	F and R	Forestry and Recreation	Double Wide
98 150804 MH	A-10	Agriculture-10 Acre	Double Wide
97 107515 000 01 MH	R-5	Rural-5 Acre	Double Wide
96 110352 000 01 MH	R-5	Rural-5 Acre	Single Wide
99 112757 RK	R-5	Rural-5 Acre	Single Family Res-Combo
99 104422 RK	R-5	Rural-5 Acre	Single Family Res-Combo
98 109742 RK	R-5	Rural-5 Acre	Single Family Res-Combo
99 112812 RK	R-5	Rural-5 Acre	Single Family Res-Combo
99 103666 RK	R-5	Rural-5 Acre	Single Family Res-Combo
99 110276 MH	R-5	Rural-5 Acre	Triple Wide
99 102467 RK	R-5	Rural-5 Acre	Single Family Res-Combo
99 110406 RK	CITY	City	Single Family Res-Combo
99 110408 RK	CITY	City	Single Family Res-Combo
99 103501 RK	R-5	Rural-5 Acre	Single Family Res-Combo
99 110818 MH	CITY	City	Double Wide
99 102816 RK	R-5	Rural-5 Acre	Single Family Res-Combo
99 103595 RK	CITY	City	Single Family Res-Combo
99 100414 RK	R-5	Rural-5 Acre	Single Family Res-Combo
99 109793 RK	R-5	Rural-5 Acre	Single Family Res-Combo
98 100407 RK	R-5	Rural-5 Acre	Single Family Res-Combo
99 100468 MH	RRT-10	Rural Resource Transition-10	Double Wide



Accessory Dwelling Units

Index # - File Name: 1.0022 - Single Family Dwellings Data\_Snohomish County.pdf

99 113344 RK	RD	Rural Diversification	Single Family Res-Combo
99 109408 RK	R-5	Rural-5 Acre	Single Family Res-Combo
97 105033 000 01 RK	R-5	Rural-5 Acre	Single Family Res-Combo
97 108143 000 01 RK	R-5	Rural-5 Acre	Single Family Res-Combo
98 101957 RK	R-5	Rural-5 Acre	Single Family Res-Combo
99 111172 RK	R-5	Rural-5 Acre	Single Family Res-Combo
99 112359 RK	R-5	Rural-5 Acre	Single Family Res-Combo
99 109578 RK	R-5	Rural-5 Acre	Single Family Res-Combo
99 100269 RK	R-5	Rural-5 Acre	Duplex-Combo
99 102117 RK	R-5	Rural-5 Acre	Single Family Res-Combo
99 102536 MH	F	Forestry	Double Wide
98 116668 RK	R-5	Rural-5 Acre	Single Family Res-Combo
98 106754 RK	R-5	Rural-5 Acre	Single Family Res-Combo
99 105420 RK	R-5	Rural-5 Acre	Single Family Res-Combo
99 105384 MH	R-5	Rural-5 Acre	Double Wide
99 105383 MH	R-5	Rural-5 Acre	Double Wide
99 104425 RK	R-5	Rural-5 Acre	Single Family Res-Combo
99 114331 RK	R-5	Rural-5 Acre	Duplex-Combo
99 116084 MH	RRT-10	Rural Resource Transition-10	Single Wide
99 101425 RK	R-7,200	Residential 7,200 sq. ft.	Single Family Res-Combo
99 102715 RK	R-9,600	Residential 9,600 sq. ft.	Single Family Res-Combo
99 111422 RK	R-5	Rural-5 Acre	Single Family Res-Combo
99 101338 RK	R-5	Rural-5 Acre	Single Family Res-Combo
98 106760 RK	R-5	Rural-5 Acre	Single Family Res-Combo
99 104748 MH	R-5	Rural-5 Acre	Triple Wide
99 114543 RK	R-5	Rural-5 Acre	Single Family Res-Combo
99 113863 RK	R-5	Rural-5 Acre	Single Family Res-Combo
99 111466 RK	R-5	Rural-5 Acre	Single Family Res-Combo
98 105269 RK	RRT-10	Rural Resource Transition-10	Single Family Res-Combo
99 102834 RK			Single Family Res-Combo
99 103163 RK	R-5	Rural-5 Acre	Single Family Res-Combo
99 101476 RK	R-5	Rural-5 Acre	Single Family Res-Combo
99 103110 RK	R-9,600	Residential 9,600 sq. ft.	Single Family Res-Combo
99 102886 RK	PRD SA-1	Suburban Agriculture-1 Acre	Single Family Res-Combo
99 109749 MH	R-5	Rural-5 Acre	Double Wide
99 104659 RK	R-5	Rural-5 Acre	Single Family Res-Combo
99 109355 MH	R-5	Rural-5 Acre	Double Wide
99 103622 RK	R-5	Rural-5 Acre	Single Family Res-Combo
97 108824 RK	R-5	Rural-5 Acre	Single Family Res-Combo
98 109124 RK	CITY	City	Duplex-Combo
97 101623 RK	R-5	Rural-5 Acre	SFR-Basic
99 105153 RK	R-5	Rural-5 Acre	Single Family Res-Combo
99 104941 MH	RRT-10	Rural Resource Transition-10	Double Wide
99 104174 MH	RRT-10	Rural Resource Transition-10	Double Wide
99 111472 RK	R-5	Rural-5 Acre	Single Family Res-Combo
99 111503 RK	R-5	Rural-5 Acre	Single Family Res-Combo
99 112841 RK	R-9,600	Residential 9,600 sq. ft.	SFR-Basic

Accessory Dwelling Units

Index # - File Name: 1.0022 - Single Family Dwellings Data\_Snohomish County.pdf

99 104543 RK	R-5	Rural-5 Acre	Single Family Res-Combo
99 104623 RK	R-5	Rural-5 Acre	Single Family Res-Combo
99 110731 RK	R-5	Rural-5 Acre	Single Family Res-Combo
98 150586 RK	R-5	Rural-5 Acre	Single Family Res-Combo
99 102866 RK	R-5	Rural-5 Acre	Single Family Res-Combo
99 109878 RK	R-5	Rural-5 Acre	Single Family Res-Combo
99 112438 RK	R-5	Rural-5 Acre	Single Family Res-Combo
99 100212 MH	R-5	Rural-5 Acre	Single Wide
99 112840 RK	R-8,400	Residential 8,400 sq. ft.	SFR-Basic
99 113075 RK	R-9,600	Residential 9,600 sq. ft.	SFR-Basic
99 109327 RK	R-5	Rural-5 Acre	Single Family Res-Combo
99 110780 RK	RRT-10	Rural Resource Transition-10	SFR-Basic
99 104943 MH	RRT-10	Rural Resource Transition-10	Double Wide
97 111272 000 01 RK	RRT-10	Rural Resource Transition-10	Single Family Res-Combo
98 109852 RK	A-10	Agriculture-10 Acre	Single Family Res-Combo
99 103236 MH	A-10	Agriculture-10 Acre	Double Wide
99 110086 RK	R-5	Rural-5 Acre	Single Family Res-Combo
99 110087 RK	R-5	Rural-5 Acre	Single Family Res-Combo
99 110902 RK	R-5	Rural-5 Acre	Single Family Res-Combo
99 110917 RK	R-5	Rural-5 Acre	Single Family Res-Combo
99 105245 RK	A-10	Agriculture-10 Acre	Single Family Res-Combo
98 106100 RK	A-10	Agriculture-10 Acre	SFR-Basic
99 105244 RK	A-10	Agriculture-10 Acre	Single Family Res-Combo
99 105256 RK	A-10	Agriculture-10 Acre	Single Family Res-Combo
99 105248 RK	A-10 : R-5	Agriculture-10 Acre : Rural-5	Single Family Res-Combo
99 105257 RK	A-10	Agriculture-10 Acre	Single Family Res-Combo
99 105250 RK	A-10 : R-5	Agriculture-10 Acre : Rural-5	Single Family Res-Combo
99 105254 RK	A-10 : R-5	Agriculture-10 Acre : Rural-5	Single Family Res-Combo
99 105249 RK	A-10	Agriculture-10 Acre	Single Family Res-Combo
99 105252 RK	A-10	Agriculture-10 Acre	Single Family Res-Combo
98 150502 RK	R-5	Rural-5 Acre	Single Family Res-Combo
97 104554 000 01 RK	R-5	Rural-5 Acre	Single Family Res-Combo
99 105278 RK	R-5	Rural-5 Acre	Single Family Res-Combo
99 103231 RK	R-5	Rural-5 Acre	Single Family Res-Combo
98 105102 RK	R-5	Rural-5 Acre	Single Family Res-Combo
99 100351 RK	R-5	Rural-5 Acre	Single Family Res-Combo
98 116808 MH	R-5	Rural-5 Acre	Triple Wide
99 111798 RK	R-5	Rural-5 Acre	Single Family Res-Combo
99 111717 RK	R-5	Rural-5 Acre	Single Family Res-Combo
99 104852 RK	R-5	Rural-5 Acre	Single Family Res-Combo
99 105316 RK	R-5	Rural-5 Acre	Single Family Res-Combo
99 101996 MH	RD	Rural Diversification	Single Wide
99 100965 RK	R-5	Rural-5 Acre	Single Family Res-Combo
98 116131 RK	R-5	Rural-5 Acre	Single Family Res-Combo
98 117064 RK	R-5	Rural-5 Acre	Single Family Res-Combo
98 150747 RK	R-5	Rural-5 Acre	SFR-Basic
98 116670 RK	R-5	Rural-5 Acre	Single Family Res-Combo

Accessory Dwelling Units

Index # - File Name: 1.0022 - Single Family Dwellings Data\_Snohomish County.pdf

99 109623 RK	R-5	Rural-5 Acre	Single Family Res-Combo
98 105270 RK	RRT-10	Rural Resource Transition-10	Single Family Res-Combo
98 117050 RK	R-5	Rural-5 Acre	Single Family Res-Combo
99 102412 RK	R-5	Rural-5 Acre	Single Family Res-Combo
99 110769 RK	R-5	Rural-5 Acre	Single Family Res-Combo
99 101883 RK	R-5	Rural-5 Acre	Single Family Res-Combo
98 106693 RK	R-5	Rural-5 Acre	Single Family Res-Combo
99 110157 RK	R-5	Rural-5 Acre	Single Family Res-Combo
99 103589 RK	R-5	Rural-5 Acre	Single Family Res-Combo
98 109405 RK	RC	Rural Conservation	Single Family Res-Combo
99 104486 MH	R-5	Rural-5 Acre	Double Wide
99 115733 RK	R-5	Rural-5 Acre	Single Family Res-Combo
99 103381 RK	R-5	Rural-5 Acre	Single Family Res-Combo
98 102955 RK	PRD-9,600	Residential 9,600 sq. ft.	Single Family Res-Combo
98 116678 RK	F	Forestry	Single Family Res-Combo
99 110571 RK	CITY	City	Single Family Res-Combo
99 110569 RK	CITY	City	Single Family Res-Combo
99 112440 RK	R-5	Rural-5 Acre	Single Family Res-Combo
95 104351 MH	MR	Multiple Residential	Double Wide
98 110067 RK	R-5	Rural-5 Acre	Single Family Res-Combo
99 114707 MH	R-5	Rural-5 Acre	Double Wide
99 112043 RK	R-5	Rural-5 Acre	Single Family Res-Combo
99 104628 RK	R-5	Rural-5 Acre	Single Family Res-Combo
99 112712 RK	R-5	Rural-5 Acre	Single Family Res-Combo
99 103764 RK	R-5	Rural-5 Acre	Single Family Res-Combo
99 111988 RK	R-5	Rural-5 Acre	Single Family Res-Combo
99 104547 RK	R-5	Rural-5 Acre	Single Family Res-Combo
99 112243 RK	R-5	Rural-5 Acre	Single Family Res-Combo
97 106709 000 01 MH	RD	Rural Diversification	Double Wide
99 103653 RK	R-5	Rural-5 Acre	Single Family Res-Combo
99 103389 MH	R-5	Rural-5 Acre	Double Wide
99 104400 RK	R-5	Rural-5 Acre	Single Family Res-Combo
99 111018 RK	R-5	Rural-5 Acre	Single Family Res-Combo
99 110771 RK	R-5	Rural-5 Acre	Single Family Res-Combo
99 109627 RK	R-5	Rural-5 Acre	Single Family Res-Combo
99 101054 RK	R-5	Rural-5 Acre	Single Family Res-Combo
98 116846 RK	R-5	Rural-5 Acre	Single Family Res-Combo
99 111002 RK	F and R	Forestry and Recreation	Single Family Res-Combo
99 105200 RK	R-5	Rural-5 Acre	Single Family Res-Combo
97 111454 RK	R-5	Rural-5 Acre	Single Family Res-Combo
97 106932 000 01 RK	F	Forestry	Single Family Res-Combo
99 112401 RK	R-5	Rural-5 Acre	Single Family Res-Combo
98 116898 RK	R-5	Rural-5 Acre	Single Family Res-Combo
98 116897 RK	R-5	Rural-5 Acre	Single Family Res-Combo
98 116999 RK	R-5	Rural-5 Acre	Single Family Res-Combo
99 102916 MH	RC	Rural Conservation	Double Wide
99 111654 MH	R-5	Rural-5 Acre	Double Wide

Accessory Dwelling Units

Index # - File Name: 1.0022 - Single Family Dwellings Data\_Snohomish County.pdf

98 104111 RK	R-5	Rural-5 Acre	Single Family Res-Combo
99 110895 RK	R-5	Rural-5 Acre	Accessory Apt Detached-Combo
99 103196 RK	R-5	Rural-5 Acre	Single Family Res-Combo
99 109289 MH	R-5	Rural-5 Acre	Single Wide
99 113546 RK	R-5	Rural-5 Acre	Single Family Res-Combo
99 113341 RK	R-5	Rural-5 Acre	Single Family Res-Combo
99 109745 MH	R-5	Rural-5 Acre	Double Wide
98 108170 RK	R-5	Rural-5 Acre	Single Family Res-Combo
99 112377 MH	R-5	Rural-5 Acre	Double Wide
99 101135 RK	R-5	Rural-5 Acre	Single Family Res-Combo
98 105381 RK	RD	Rural Diversification	Single Family Res-Combo
99 113510 RK	RD	Rural Diversification	Single Family Res-Combo
99 112911 RK	R-5	Rural-5 Acre	Single Family Res-Combo
98 116883 RK	R-5	Rural-5 Acre	Single Family Res-Combo
99 103421 MH	RD	Rural Diversification	Double Wide
98 150475 RK	R-5	Rural-5 Acre	Single Family Res-Combo
97 104204 000 01 MH	RC	Rural Conservation	Double Wide
99 112620 RK	R-5	Rural-5 Acre	Single Family Res-Combo
98 109870 MH	A-10	Agriculture-10 Acre	Triple Wide
98 150971 MH	RD	Rural Diversification	Single Wide
99 104398 MH	RD	Rural Diversification	Double Wide
97 108837 000 01 MH	F : R-5	Forestry : Rural-5 Acre	Double Wide
99 115243 RK	R-5	Rural-5 Acre	SFR-Basic
98 108321 MH	R-5	Rural-5 Acre	Double Wide
99 104560 RK	RD	Rural Diversification	Single Family Res-Combo
99 104236 MH	R-5	Rural-5 Acre	Double Wide
98 150645 RK	R-5	Rural-5 Acre	SFR-Basic
99 105350 RK	R-5	Rural-5 Acre	Single Family Res-Combo
99 109928 MH	R-5	Rural-5 Acre	Double Wide
99 110648 MH	R-5	Rural-5 Acre	Double Wide
99 113325 MH	R-5	Rural-5 Acre	Triple Wide
99 104088 RK	R-5	Rural-5 Acre	Single Family Res-Combo
99 114937 MH	R-5	Rural-5 Acre	Double Wide
99 100842 MH	R-5	Rural-5 Acre	Double Wide
99 104599 MH	R-5	Rural-5 Acre	Single Wide
99 101779 MH	R-5	Rural-5 Acre	Triple Wide
99 104853 RK	R-5	Rural-5 Acre	Single Family Res-Combo
98 108375 RK	R-5	Rural-5 Acre	Single Family Res-Combo
97 110823 MH	R-5	Rural-5 Acre	Double Wide
99 104972 RK	R-5	Rural-5 Acre	Single Family Res-Combo
99 103242 RK	R-5	Rural-5 Acre	Single Family Res-Combo
99 113206 RK	R-5	Rural-5 Acre	Single Family Res-Combo
99 100610 RK	R-5	Rural-5 Acre	Single Family Res-Combo
99 105378 RK	R-5	Rural-5 Acre	Single Family Res-Combo
99 104536 MH	R-5	Rural-5 Acre	Double Wide
99 110404 RK	R-5	Rural-5 Acre	Single Family Res-Combo
99 104993 RK	R-5	Rural-5 Acre	Single Family Res-Combo

Accessory Dwelling Units

Index # - File Name: 1.0022 - Single Family Dwellings Data\_Snohomish County.pdf

99 103247 MH	R-5	Rural-5 Acre	Double Wide
99 104206 RK	R-5	Rural-5 Acre	Single Family Res-Combo
99 101978 RK	R-5	Rural-5 Acre	Single Family Res-Combo
99 114696 RK	R-5	Rural-5 Acre	Single Family Res-Combo
99 112531 MH	R-5	Rural-5 Acre	Triple Wide
99 112219 RK	CITY	City	Single Family Res-Combo
99 102352 MH	R-5	Rural-5 Acre	Double Wide
99 113385 MH	R-5	Rural-5 Acre	Triple Wide
99 104933 MH	R-5	Rural-5 Acre	Double Wide
97 108493 MH	R-5	Rural-5 Acre	Double Wide
98 108206 RK	R-5	Rural-5 Acre	Single Family Res-Combo
99 101151 MH	R-5	Rural-5 Acre	Single Wide
99 104095 RK	R-5	Rural-5 Acre	Single Family Res-Combo
98 151190 RK	R-5	Rural-5 Acre	Single Family Res-Combo
98 110541 RK	R-5	Rural-5 Acre	Single Family Res-Combo
99 112055 RK	CITY	City	Single Family Res-Combo
99 111191 MH	R-5	Rural-5 Acre	Single Wide
98 150598 RK	R-5	Rural-5 Acre	Single Family Res-Combo
99 109422 RK	R-5	Rural-5 Acre	Single Family Res-Combo
98 110727 MH	R-5	Rural-5 Acre	Double Wide
98 109330 MH	R-5	Rural-5 Acre	Double Wide
99 109467 MH	R-5	Rural-5 Acre	Triple Wide
99 111987 MH	R-5	Rural-5 Acre	Double Wide
98 102719 MH	R-5	Rural-5 Acre	Double Wide
98 117029 MH	R-5	Rural-5 Acre	Double Wide
99 110588 MH	R-5	Rural-5 Acre	Double Wide
99 115898 MH	R-5	Rural-5 Acre	Double Wide
99 105414 MH	R-5	Rural-5 Acre	Double Wide
98 110172 RK	R-5	Rural-5 Acre	Single Family Res-Combo
99 100152 RK	R-5	Rural-5 Acre	Single Family Res-Combo
98 110627 MH	R-5	Rural-5 Acre	Double Wide
99 104511 RK	R-5	Rural-5 Acre	Single Family Res-Combo
99 111971 MH	RRT-10	Rural Resource Transition-10	Double Wide
98 150899 RK	R-5	Rural-5 Acre	Single Family Res-Combo
99 110715 RK	R-5	Rural-5 Acre	Single Family Res-Combo
97 111772 RK	R-5	Rural-5 Acre	Single Family Res-Combo
99 114022 MH	R-5	Rural-5 Acre	Triple Wide
98 150928 MH	R-5	Rural-5 Acre	Double Wide
98 117002 RK	R-5	Rural-5 Acre	Single Family Res-Combo
99 104081 RK	R-5	Rural-5 Acre	Single Family Res-Combo
99 113306 RK	R-5	Rural-5 Acre	Single Family Res-Combo
99 104251 MH	SA-1	Suburban Agriculture-1 Acre	Double Wide
99 112492 MH	R-5	Rural-5 Acre	Double Wide
99 113787 RK	CITY	City	Duplex-Combo
99 105387 MH	R-5	Rural-5 Acre	Double Wide
98 150496 MH	R-5	Rural-5 Acre	Double Wide
99 102560 MH	R-5	Rural-5 Acre	Double Wide

Accessory Dwelling Units

Index # - File Name: 1.0022 - Single Family Dwellings Data\_Snohomish County.pdf

99 102005 MH	R-5	Rural-5 Acre	Double Wide
99 103259 MH	RRT-10	Rural Resource Transition-10	Double Wide
99 103137 RK	CITY	City	Single Family Res-Combo
99 114084 RK	CITY	City	Duplex-Combo
99 112261 MH	SA-1	Suburban Agriculture-1 Acre	Double Wide
99 110805 RK	CITY	City	Single Family Res-Combo
99 104058 MH	CITY	City	Double Wide
97 104120 000 01 MH	R-5	Rural-5 Acre	Double Wide
99 105158 RK	R-5	Rural-5 Acre	Single Family Res-Combo
99 103020 RK	R-5	Rural-5 Acre	Single Family Res-Combo
99 112464 MH	RRT-10	Rural Resource Transition-10	Double Wide
99 104687 MH	R-5	Rural-5 Acre	Single Wide
99 111504 RK	R-5	Rural-5 Acre	Single Family Res-Combo
98 116914 RK	R-5	Rural-5 Acre	Single Family Res-Combo
99 111727 RK	R-5	Rural-5 Acre	Single Family Res-Combo
99 104751 RK	R-5	Rural-5 Acre	Single Family Res-Combo
98 116119 RK	R-5	Rural-5 Acre	Single Family Res-Combo
98 116094 RK	R-5	Rural-5 Acre	Single Family Res-Combo
98 107265 RK	R-5	Rural-5 Acre	Single Family Res-Combo
98 109921 RK	R-5	Rural-5 Acre	Single Family Res-Combo
98 108661 RK	R-5	Rural-5 Acre	Single Family Res-Combo
99 101923 RK	R-5	Rural-5 Acre	SFR-Basic
99 103888 RK	R-5	Rural-5 Acre	SFR-Basic
99 103887 RK	R-5	Rural-5 Acre	Single Family Res-Combo
98 150520 RK	R-5	Rural-5 Acre	SFR-Basic
98 117003 RK	R-5	Rural-5 Acre	SFR-Basic
98 117004 RK	R-5	Rural-5 Acre	Single Family Res-Combo
98 103329 RK	R-5	Rural-5 Acre	SFR-Basic
98 105824 RK	R-5	Rural-5 Acre	Single Family Res-Combo
98 103461 RK	R-5	Rural-5 Acre	SFR-Basic
98 151016 RK	R-5	Rural-5 Acre	SFR-Basic
98 103457 RK	R-5	Rural-5 Acre	SFR-Basic
99 102015 RK	R-5	Rural-5 Acre	SFR-Basic
98 151019 RK	R-5	Rural-5 Acre	SFR-Basic
98 151018 RK	R-5	Rural-5 Acre	SFR-Basic
98 107056 RK	R-5	Rural-5 Acre	SFR-Basic
99 100581 RK	R-5	Rural-5 Acre	Single Family Res-Combo
98 116559 MH	R-5	Rural-5 Acre	Double Wide
99 100552 RK	RRT-10	Rural Resource Transition-10	Single Family Res-Combo
99 102377 RK	RRT-10	Rural Resource Transition-10	Single Family Res-Combo
98 116881 MH	R-5	Rural-5 Acre	Double Wide
97 109548 MH	R-5	Rural-5 Acre	Single Wide
98 109413 RK	R-5	Rural-5 Acre	Single Family Res-Combo
99 100230 RK	R-5	Rural-5 Acre	SFR-Basic
99 109317 MH	R-5 : SA-1	Rural-5 Acre : Suburban Agri	Triple Wide
99 112308 MH	SA-1	Suburban Agriculture-1 Acre	Double Wide
99 101986 RK	SA-1	Suburban Agriculture-1 Acre	SFR-Basic

Accessory Dwelling Units

Index # - File Name: 1.0022 - Single Family Dwellings Data\_Snohomish County.pdf

99 103334 MH	SA-1	Suburban Agriculture-1 Acre	Single Wide
99 111631 MH	R-5	Rural-5 Acre	Double Wide
99 104747 RK	RRT-10	Rural Resource Transition-10	Single Family Res-Combo
99 100119 RK	R-5	Rural-5 Acre	Single Family Res-Combo
99 101377 RK	R-5	Rural-5 Acre	Single Family Res-Combo
98 106155 RK	R-5	Rural-5 Acre	Single Family Res-Combo
99 100387 MH	CITY	City	Double Wide
99 100367 RK	CITY	City	Single Family Res-Combo
99 102904 RK	R-5	Rural-5 Acre	Single Family Res-Combo
99 100851 RK	R-5	Rural-5 Acre	SFR-Basic
99 100850 RK	R-5	Rural-5 Acre	SFR-Basic
99 100849 RK	R-5	Rural-5 Acre	SFR-Basic
99 100854 RK	R-5	Rural-5 Acre	SFR-Basic
99 104500 RK	R-9,600	Residential 9,600 sq. ft.	Single Family Res-Combo
99 113944 MH	R-5	Rural-5 Acre	Double Wide
98 110233 RK	R-9,600	Residential 9,600 sq. ft.	SFR-Basic
98 110232 RK	R-9,600	Residential 9,600 sq. ft.	SFR-Basic
98 107938 RK	R-9,600	Residential 9,600 sq. ft.	Single Family Res-Combo
99 102384 RK	R-5	Rural-5 Acre	Single Family Res-Combo
99 110110 MH	R-5	Rural-5 Acre	Double Wide
99 103338 MH	R-5	Rural-5 Acre	Double Wide
99 110135 RK	R-5	Rural-5 Acre	Single Family Res-Combo
99 105460 RK	R-5	Rural-5 Acre	SFR-Basic
99 100852 RK	R-5	Rural-5 Acre	SFR-Basic
99 100839 MH	R-5	Rural-5 Acre	Double Wide
98 109034 RK	R-5	Rural-5 Acre	Single Family Res-Combo
99 101221 RK	R-5	Rural-5 Acre	Single Family Res-Combo
99 113922 MH	RRT-10	Rural Resource Transition-10	Double Wide
98 150711 RK	RRT-10	Rural Resource Transition-10	Single Family Res-Combo
98 109436 MH	R-5	Rural-5 Acre	Double Wide
97 102081 000 01 MH	RRT-10	Rural Resource Transition-10	Single Wide
99 100243 RK	R-5	Rural-5 Acre	Single Family Res-Combo
99 111214 MH	R-5	Rural-5 Acre	Double Wide
99 112807 MH	R-5	Rural-5 Acre	Triple Wide
99 115048 RK	R-5	Rural-5 Acre	Single Family Res-Combo
99 113035 RK	R-5	Rural-5 Acre	SFR-Basic
99 110529 MH	R-5	Rural-5 Acre	Double Wide
99 100540 MH	R-5	Rural-5 Acre	Double Wide
99 113919 RK	RC	Rural Conservation	Single Family Res-Combo
98 116222 MH	CITY	City	Single Wide
96 108456 000 01 RK	CITY	City	Single Family Res-Combo
99 105100 RK	R-5	Rural-5 Acre	Single Family Res-Combo
99 105208 RK	R-5	Rural-5 Acre	Single Family Res-Combo
97 101389 000 01 MH	R-5	Rural-5 Acre	Double Wide
99 110206 MH	R-5	Rural-5 Acre	Double Wide
99 111963 RK	R-5	Rural-5 Acre	Single Family Res-Combo
98 109343 RK	A-10 : R-5	Agriculture-10 Acre : Rural-5	Single Family Res-Combo

Accessory Dwelling Units

Index # - File Name: 1.0022 - Single Family Dwellings Data\_Snohomish County.pdf

99 112143 RK	R-5	Rural-5 Acre	Single Family Res-Combo
98 108652 MH	R-5	Rural-5 Acre	Single Wide
99 105315 RK	R-5	Rural-5 Acre	Single Family Res-Combo
99 110356 MH	R-5	Rural-5 Acre	Double Wide
99 102382 RK	WFB	Waterfront Beach	Single Family Res-Combo
99 103371 RK	R-8,400	Residential 8,400 sq. ft.	Duplex-Basic
99 101271 RK	R-7,200	Residential 7,200 sq. ft.	Duplex-Basic
99 112851 RK	R-9,600	Residential 9,600 sq. ft.	Single Family Res-Combo
99 103197 RK	R-9,600	Residential 9,600 sq. ft.	Single Family Res-Combo
99 100507 MH	CITY	City	Double Wide
99 104799 RK	CITY	City	Duplex-Combo
99 111676 RK	R-8,400	Residential 8,400 sq. ft.	Single Family Res-Combo
98 150499 RK	R-9,600	Residential 9,600 sq. ft.	Single Family Res-Combo
99 101378 MH	R-8,400	Residential 8,400 sq. ft.	Double Wide
99 109882 RK	A-10	Agriculture-10 Acre	Single Family Res-Combo
99 110875 RK	R-8,400	Residential 8,400 sq. ft.	Duplex-Combo
99 102549 RK	R-5	Rural-5 Acre	Single Family Res-Combo
99 110047 RK	R-8,400	Residential 8,400 sq. ft.	Single Family Res-Combo
98 107317 RK	R-5	Rural-5 Acre	Single Family Res-Combo
99 101632 RK	R-5	Rural-5 Acre	Single Family Res-Combo
99 112760 RK	R-9,600	Residential 9,600 sq. ft.	Single Family Res-Combo
97 103852 000 01 RK	R-5	Rural-5 Acre	Single Family Res-Combo
99 112669 RK	R-5	Rural-5 Acre	Single Family Res-Combo
99 103871 RK	R-5	Rural-5 Acre	Single Family Res-Combo
98 108092 RK	R-5	Rural-5 Acre	Single Family Res-Combo
99 103515 RK	R-5	Rural-5 Acre	Single Family Res-Combo
98 150955 MH	R-5	Rural-5 Acre	Double Wide
99 113943 MH	R-5	Rural-5 Acre	Triple Wide
99 100597 MH	R-5	Rural-5 Acre	Double Wide
99 111628 RK	R-5	Rural-5 Acre	Single Family Res-Combo
98 109918 MH	R-5	Rural-5 Acre	Single Wide
99 109567 RK	R-9,600	Residential 9,600 sq. ft.	Single Family Res-Combo
99 111861 RK	R-5	Rural-5 Acre	Single Family Res-Combo
99 115088 RK	R-5	Rural-5 Acre	Single Family Res-Combo
98 116832 MH	R-5	Rural-5 Acre	Double Wide
99 111519 RK	R-5	Rural-5 Acre	Single Family Res-Combo
99 109466 RK	R-5	Rural-5 Acre	Single Family Res-Combo
99 114432 RK	R-5	Rural-5 Acre	Single Family Res-Combo
99 103865 MH	R-5	Rural-5 Acre	Double Wide
99 103107 RK	R-5	Rural-5 Acre	Single Family Res-Combo
99 111457 RK	R-5	Rural-5 Acre	Single Family Res-Combo
98 104050 RK	R-5	Rural-5 Acre	Single Family Res-Combo
99 105238 RK	R-5	Rural-5 Acre	Single Family Res-Combo
99 100001 MH	R-5	Rural-5 Acre	Double Wide
99 112809 RK	R-5	Rural-5 Acre	Single Family Res-Combo
99 105304 MH	RC	Rural Conservation	Double Wide
99 104455 RK	R-9,600	Residential 9,600 sq. ft.	Single Family Res-Combo



Accessory Dwelling Units

Index # - File Name: 1.0022 - Single Family Dwellings Data\_Snohomish County.pdf

99 112764 RK	R-9,600	Residential 9,600 sq. ft.	Single Family Res-Combo
99 104558 RK	R-8,400	Residential 8,400 sq. ft.	Single Family Res-Combo
99 110200 RK	R-8,400	Residential 8,400 sq. ft.	Single Family Res-Combo
99 110197 RK	R-8,400	Residential 8,400 sq. ft.	Single Family Res-Combo
99 103476 RK	R-8,400	Residential 8,400 sq. ft.	Single Family Res-Combo
99 109343 MH	R-5	Rural-5 Acre	Triple Wide
98 108458 RK	F	Forestry	Single Family Res-Combo
99 110115 RK	R-12,500	Residential 12,500 sq. ft.	Single Family Res-Combo
97 103913 000 01 MH	R-12,500	Residential 12,500 sq. ft.	Single Wide
99 102751 RK	R-12,500	Residential 12,500 sq. ft.	Single Family Res-Combo
99 101823 RK	R-8,400	Residential 8,400 sq. ft.	Duplex-Combo
99 103192 MH	A-10	Agriculture-10 Acre	Double Wide
99 102385 MH	F	Forestry	Double Wide
99 104745 MH	F	Forestry	Single Wide
99 103720 MH	R-5	Rural-5 Acre	Double Wide
99 100495 RK	R-5	Rural-5 Acre	Single Family Res-Combo
99 112037 RK	R-5	Rural-5 Acre	Single Family Res-Combo
98 116576 RK	R-5	Rural-5 Acre	Single Family Res-Combo
99 113129 RK	R-5	Rural-5 Acre	SFR-Basic
99 101261 MH	R-5	Rural-5 Acre	Double Wide
97 109764 000 01 MH	R-5	Rural-5 Acre	Single Wide
99 113193 MH	R-5	Rural-5 Acre	Triple Wide
98 150483 RK	R-5	Rural-5 Acre	Single Family Res-Combo
98 150484 RK	R-5	Rural-5 Acre	Single Family Res-Combo
98 116506 RK	F	Forestry	Single Family Res-Combo
99 104062 RK	F	Forestry	Single Family Res-Combo
99 114312 RK	R-8,400	Residential 8,400 sq. ft.	Single Family Res-Combo
99 101655 RK	R-5	Rural-5 Acre	Single Family Res-Combo
99 101729 RK	R-5	Rural-5 Acre	Single Family Res-Combo
99 101722 RK	R-5	Rural-5 Acre	Single Family Res-Combo
99 115332 RK	R-9,600	Residential 9,600 sq. ft.	Single Family Res-Combo
98 151164 MH	R-5	Rural-5 Acre	Triple Wide
99 112244 RK	R-5	Rural-5 Acre	Single Family Res-Combo
99 104790 RK	R-5	Rural-5 Acre	Single Family Res-Combo
99 110814 RK	R-9,600	Residential 9,600 sq. ft.	Duplex-Combo
98 110629 RK	R-8,400	Residential 8,400 sq. ft.	Single Family Res-Combo
99 110896 RK	R-7,200	Residential 7,200 sq. ft.	Duplex-Combo
99 104780 RK	R-8,400 : WFB	Residential 8,400 sq. ft. : Wa	Single Family Res-Combo
99 112607 RK	MR	Multiple Residential	Duplex-Combo
99 103536 MH	R-5	Rural-5 Acre	Double Wide
99 104219 RK	R-5	Rural-5 Acre	Single Family Res-Combo
99 112248 RK	F	Forestry	Single Family Res-Combo
98 110369 RK	R-5	Rural-5 Acre	Single Family Res-Combo
99 110041 RK	R-5	Rural-5 Acre	Single Family Res-Combo
99 110893 RK	R-7,200	Residential 7,200 sq. ft.	SFR-Basic
99 110442 RK	R-5	Rural-5 Acre	Single Family Res-Combo
97 109271 000 01 RK	R-5	Rural-5 Acre	Single Family Res-Combo

Accessory Dwelling Units

Index # - File Name: 1.0022 - Single Family Dwellings Data\_Snohomish County.pdf

98 151136 RK	F	Forestry	Single Family Res-Combo
99 113276 MH	R-5	Rural-5 Acre	Double Wide
99 110230 RK	R-5	Rural-5 Acre	Single Family Res-Combo
99 103635 MH	R-5	Rural-5 Acre	Double Wide
99 103822 RK	R-5	Rural-5 Acre	Single Family Res-Combo
99 100239 RK	R-5	Rural-5 Acre	Single Family Res-Combo
99 104103 RK	R-5	Rural-5 Acre	Single Family Res-Combo
98 110287 RK	R-5	Rural-5 Acre	Single Family Res-Combo
98 117072 RK	R-5	Rural-5 Acre	Single Family Res-Combo
99 104744 RK	R-7,200	Residential 7,200 sq. ft.	Single Family Res-Combo
99 111888 RK	R-9,600	Residential 9,600 sq. ft.	Single Family Res-Combo
99 109695 RK	R-9,600	Residential 9,600 sq. ft.	Duplex-Combo
97 104522 000 01 RK	R-5	Rural-5 Acre	Single Family Res-Combo
99 103568 RK	A-10	Agriculture-10 Acre	Single Family Res-Combo
98 151187 RK	R-5	Rural-5 Acre	Single Family Res-Combo
99 109536 RK	F	Forestry	Single Family Res-Combo
98 109272 MH	RC	Rural Conservation	Double Wide
98 100857 RK	R-5	Rural-5 Acre	Accessory Apt Detached-Combo
99 111579 RK	R-5	Rural-5 Acre	Single Family Res-Combo
99 110103 RK	R-5	Rural-5 Acre	Single Family Res-Combo
98 109724 RK	R-5	Rural-5 Acre	Single Family Res-Combo
99 101542 RK	R-5	Rural-5 Acre	Single Family Res-Combo
99 104190 RK	R-5	Rural-5 Acre	Single Family Res-Combo
99 104540 RK	R-5	Rural-5 Acre	Single Family Res-Combo
98 108551 RK	F	Forestry	Single Family Res-Combo
97 102836 000 01 RK	A-10	Agriculture-10 Acre	Single Family Res-Combo
99 111435 RK	R-5	Rural-5 Acre	Single Family Res-Combo
98 150593 RK	R-5	Rural-5 Acre	Single Family Res-Combo
99 105231 RK	LDMR	Low Density Multiple Reside	Single Family Res-Combo
99 100502 RK	LDMR	Low Density Multiple Reside	Single Family Res-Combo
99 100142 RK	F	Forestry	Single Family Res-Combo
99 103092 MH	R-5	Rural-5 Acre	Double Wide
99 110626 MH	R-5	Rural-5 Acre	Double Wide
99 110861 MH	R-5	Rural-5 Acre	Single Wide
99 113980 MH	R-5	Rural-5 Acre	Double Wide
99 111846 MH	R-5	Rural-5 Acre	Triple Wide
99 114087 RK	R-5	Rural-5 Acre	Single Family Res-Combo
99 110862 MH	R-5	Rural-5 Acre	Single Wide
97 105801 RK	R-5	Rural-5 Acre	Single Family Res-Combo
97 105803 RK	R-5	Rural-5 Acre	Single Family Res-Combo
99 103909 RK	PRD-9,600	Residential 9,600 sq. ft.	Single Family Res-Combo
99 103101 RK	PRD-9,600	Residential 9,600 sq. ft.	Single Family Res-Combo
99 103912 RK	PRD-9,600	Residential 9,600 sq. ft.	Single Family Res-Combo
99 104171 RK	PRD-9,600	Residential 9,600 sq. ft.	Single Family Res-Combo
99 100453 RK	PRD-9,600	Residential 9,600 sq. ft.	Single Family Res-Combo
99 101552 RK	PRD-9,600	Residential 9,600 sq. ft.	Single Family Res-Combo
99 100986 RK	PRD-9,600	Residential 9,600 sq. ft.	Single Family Res-Combo

Accessory Dwelling Units

Index # - File Name: 1.0022 - Single Family Dwellings Data\_Snohomish County.pdf

98 151110 RK	PRD-9,600	Residential 9,600 sq. ft.	Single Family Res-Combo
98 150749 RK	PRD-9,600	Residential 9,600 sq. ft.	Single Family Res-Combo
99 104761 RK	PRD-9,600	Residential 9,600 sq. ft.	Single Family Res-Combo
99 110400 RK	PRD-9,600	Residential 9,600 sq. ft.	Single Family Res-Combo
99 101644 RK	PRD-9,600	Residential 9,600 sq. ft.	Single Family Res-Combo
99 110782 RK	R-5	Rural-5 Acre	Single Family Res-Combo
99 103558 RK	R-5	Rural-5 Acre	Single Family Res-Combo
98 116585 RK	R-5	Rural-5 Acre	Single Family Res-Combo
99 109789 RK	R-5	Rural-5 Acre	Single Family Res-Combo
99 101290 RK	R-5	Rural-5 Acre	Single Family Res-Combo
98 150904 RK	R-5	Rural-5 Acre	Single Family Res-Combo
99 103632 RK	R-5	Rural-5 Acre	Single Family Res-Combo
99 110799 MH	R-5	Rural-5 Acre	Double Wide
99 100836 RK	R-5	Rural-5 Acre	Single Family Res-Combo
98 102380 MH	RC	Rural Conservation	Double Wide
99 101069 RK	R-5	Rural-5 Acre	Single Family Res-Combo
98 109891 RK	A-10	Agriculture-10 Acre	Single Family Res-Combo
98 150780 RK	R-5	Rural-5 Acre	Single Family Res-Combo
99 111651 RK	R-20,000	Residential 20,000 sq. ft.	SFR-Basic
99 109866 RK	CITY	City	SFR-Basic
99 110576 RK	R-20,000	Residential 20,000 sq. ft.	Single Family Res-Combo
99 100234 RK	R-20,000	Residential 20,000 sq. ft.	Single Family Res-Combo
99 100240 RK	R-20,000	Residential 20,000 sq. ft.	Single Family Res-Combo
99 109703 RK	R-5	Rural-5 Acre	Single Family Res-Combo
98 151088 RK	CITY	City	SFR-Basic
98 151090 RK	CITY	City	SFR-Basic
98 151092 RK	CITY	City	SFR-Basic
99 109859 RK	CITY	City	SFR-Basic
99 112224 RK	CITY	City	SFR-Basic
98 151096 RK	CITY	City	SFR-Basic
98 151097 RK	CITY	City	SFR-Basic
99 109860 RK	CITY	City	SFR-Basic
99 109871 RK	CITY	City	SFR-Basic
99 109864 RK	CITY	City	SFR-Basic
98 151099 RK	CITY	City	SFR-Basic
98 151101 RK	CITY	City	SFR-Basic
98 104400 RK	PRD SA-1	Suburban Agriculture-1 Acre	Single Family Res-Combo
99 103106 RK	PRD SA-1	Suburban Agriculture-1 Acre	Single Family Res-Combo
98 109486 RK	PRD SA-1	Suburban Agriculture-1 Acre	Single Family Res-Combo
99 104612 RK	R-5	Rural-5 Acre	Single Family Res-Combo
99 111195 RK	R-5	Rural-5 Acre	Single Family Res-Combo
99 114120 RK	R-5	Rural-5 Acre	Single Family Res-Combo
98 150476 RK	R-5	Rural-5 Acre	Single Family Res-Combo
98 108894 RK	R-5	Rural-5 Acre	Single Family Res-Combo
98 108765 RK	R-5	Rural-5 Acre	Single Family Res-Combo
99 101358 RK	R-5	Rural-5 Acre	Single Family Res-Combo
99 110044 RK	R-5	Rural-5 Acre	Single Family Res-Combo

Accessory Dwelling Units

Index # - File Name: 1.0022 - Single Family Dwellings Data\_Snohomish County.pdf

97 104661 000 01 RK	R-5	Rural-5 Acre	Single Family Res-Combo
97 109341 MH	R-5	Rural-5 Acre	Double Wide
99 104538 RK	R-5	Rural-5 Acre	Single Family Res-Combo
99 102136 RK	R-5	Rural-5 Acre	Single Family Res-Combo
99 103037 RK	R-5	Rural-5 Acre	Single Family Res-Combo
99 110740 MH	CITY	City	MH Park-Double Wide
99 112354 MH	CITY	City	MH Park-Double Wide
99 104365 MH	CITY	City	MH Park-Double Wide
99 113317 MH	CITY	City	MH Park-Double Wide
99 101727 MH	CITY	City	MH Park-Double Wide
99 111405 MH	CITY	City	MH Park-Double Wide
99 110982 MH	CITY	City	MH Park-Double Wide
99 111593 MH	CITY	City	MH Park-Double Wide
99 112356 MH	CITY	City	MH Park-Double Wide
99 110439 MH	CITY	City	Double Wide
99 112295 MH	CITY	City	MH Park-Double Wide
99 111490 MH	CITY	City	MH Park-Double Wide
99 101293 RK	LDMR	Low Density Multiple Reside	Duplex-Combo
99 103618 RK	LDMR	Low Density Multiple Reside	Duplex-Basic
99 105340 RK	R-5	Rural-5 Acre	Single Family Res-Combo
99 100969 MH	R-5	Rural-5 Acre	Double Wide
99 100401 RK	R-5	Rural-5 Acre	Single Family Res-Combo
97 110574 MH	R-5	Rural-5 Acre	Double Wide
98 103648 RK	R-5	Rural-5 Acre	Single Family Res-Combo
97 107997 000 01 MH	RB	Rural Business	Double Wide
99 101005 RK	R-5	Rural-5 Acre	Single Family Res-Combo
99 109348 RK	RRT-10	Rural Resource Transition-10	Single Family Res-Combo
97 107450 MH	R-5	Rural-5 Acre	Double Wide
99 103450 RK	F and R : R-5	Forestry and Recreation : Ru	Single Family Res-Combo
98 151100 RK	CITY	City	SFR-Basic
99 104706 RK	PRD-LDMR	Low Density Multiple Reside	SFR-Basic
99 104404 RK	R-5	Rural-5 Acre	Single Family Res-Combo
99 110822 RK	CITY	City	Single Family Res-Combo
99 105451 RK	R-5	Rural-5 Acre	Single Family Res-Combo
98 151087 RK	CITY	City	SFR-Basic
98 151089 RK	CITY	City	SFR-Basic
99 109858 RK	CITY	City	SFR-Basic
98 151093 RK	CITY	City	SFR-Basic
98 151094 RK	CITY	City	SFR-Basic
98 151095 RK	CITY	City	SFR-Basic
99 109869 RK	CITY	City	SFR-Basic
99 109870 RK	CITY	City	SFR-Basic
99 109872 RK	CITY	City	SFR-Basic
98 151098 RK	CITY	City	SFR-Basic
98 109138 RK	PRD-LDMR	Low Density Multiple Reside	Single Family Res-Combo
98 108848 RK	PRD-LDMR	Low Density Multiple Reside	Single Family Res-Combo
99 103944 RK	PRD-LDMR	Low Density Multiple Reside	SFR-Basic

Accessory Dwelling Units

Index # - File Name: 1.0022 - Single Family Dwellings Data\_Snohomish County.pdf

99 103947 RK	PRD-LDMR	Low Density Multiple Reside SFR-Basic
99 103948 RK	PRD-LDMR	Low Density Multiple Reside SFR-Basic
99 103949 RK	PRD-LDMR	Low Density Multiple Reside SFR-Basic
99 103951 RK	PRD-LDMR	Low Density Multiple Reside SFR-Basic
99 104711 RK	PRD-LDMR	Low Density Multiple Reside SFR-Basic
99 104707 RK	PRD-LDMR	Low Density Multiple Reside SFR-Basic
99 104712 RK	PRD-LDMR	Low Density Multiple Reside SFR-Basic
99 104708 RK	PRD-LDMR	Low Density Multiple Reside SFR-Basic
99 104713 RK	PRD-LDMR	Low Density Multiple Reside SFR-Basic
99 111073 RK	PRD-LDMR	Low Density Multiple Reside SFR-Basic
99 111126 RK	PRD-LDMR	Low Density Multiple Reside SFR-Basic
99 112475 RK	PRD-LDMR	Low Density Multiple Reside SFR-Basic
99 112726 RK	PRD-LDMR	Low Density Multiple Reside SFR-Basic
99 111129 RK	PRD-LDMR	Low Density Multiple Reside SFR-Basic
99 111131 RK	PRD-LDMR	Low Density Multiple Reside SFR-Basic
99 111139 RK	PRD-LDMR	Low Density Multiple Reside SFR-Basic
99 111138 RK	PRD-LDMR	Low Density Multiple Reside SFR-Basic
99 112727 RK	PRD-LDMR	Low Density Multiple Reside SFR-Basic
99 113342 RK	PRD-LDMR	Low Density Multiple Reside SFR-Basic
99 113343 RK	PRD-LDMR	Low Density Multiple Reside SFR-Basic
99 112729 RK	PRD-LDMR	Low Density Multiple Reside SFR-Basic
99 111140 RK	PRD-LDMR	Low Density Multiple Reside SFR-Basic
99 113133 RK	R-5	Rural-5 Acre Single Family Res-Combo
99 110614 RK	PRD-LDMR	Low Density Multiple Reside SFR-Basic
99 111633 RK	PRD-LDMR	Low Density Multiple Reside SFR-Basic
99 111634 RK	PRD-LDMR	Low Density Multiple Reside SFR-Basic
99 110613 RK	PRD-LDMR	Low Density Multiple Reside SFR-Basic
99 110619 RK	PRD-LDMR	Low Density Multiple Reside SFR-Basic
99 110615 RK	PRD-LDMR	Low Density Multiple Reside SFR-Basic
99 110618 RK	PRD-LDMR	Low Density Multiple Reside SFR-Basic
99 110617 RK	PRD-LDMR	Low Density Multiple Reside SFR-Basic
99 110616 RK	PRD-LDMR	Low Density Multiple Reside SFR-Basic
99 110184 RK	PRD-LDMR	Low Density Multiple Reside SFR-Basic
99 110178 RK	PRD-LDMR	Low Density Multiple Reside SFR-Basic
99 110189 RK	PRD-LDMR	Low Density Multiple Reside SFR-Basic
99 110180 RK	PRD-LDMR	Low Density Multiple Reside SFR-Basic
99 110181 RK	PRD-LDMR	Low Density Multiple Reside SFR-Basic
99 110190 RK	PRD-LDMR	Low Density Multiple Reside SFR-Basic
98 109545 RK	PRD-LDMR	Low Density Multiple Reside Single Family Res-Combo
99 103930 RK	PRD-LDMR	Low Density Multiple Reside SFR-Basic
99 103932 RK	PRD-LDMR	Low Density Multiple Reside SFR-Basic
99 103933 RK	PRD-LDMR	Low Density Multiple Reside SFR-Basic
98 109135 RK	PRD-LDMR	Low Density Multiple Reside Single Family Res-Combo
98 102379 RK	PRD-LDMR	Low Density Multiple Reside Single Family Res-Combo
99 103937 RK	PRD-LDMR	Low Density Multiple Reside SFR-Basic
99 103939 RK	PRD-LDMR	Low Density Multiple Reside SFR-Basic
99 103940 RK	PRD-LDMR	Low Density Multiple Reside SFR-Basic

Accessory Dwelling Units

Index # - File Name: 1.0022 - Single Family Dwellings Data\_Snohomish County.pdf

98 106275 RK	CITY	City	SFR-Basic
99 101944 RK	CITY	City	Single Family Res-Combo
99 103303 RK	CITY	City	SFR-Basic
98 106276 RK	CITY	City	SFR-Basic
99 111951 RK	R-5	Rural-5 Acre	Single Family Res-Combo
98 117074 MH	R-5	Rural-5 Acre	Double Wide
98 104207 RK	R-5	Rural-5 Acre	Single Family Res-Combo
99 110305 RK	R-9,600	Residential 9,600 sq. ft.	SFR-Basic
98 107251 RK	R-9,600	Residential 9,600 sq. ft.	Single Family Res-Combo
99 103860 RK	R-9,600	Residential 9,600 sq. ft.	SFR-Basic
99 103599 RK	R-9,600	Residential 9,600 sq. ft.	Single Family Res-Combo
99 103861 RK	R-9,600	Residential 9,600 sq. ft.	SFR-Basic
99 103675 RK	R-9,600	Residential 9,600 sq. ft.	SFR-Basic
99 103677 RK	R-9,600	Residential 9,600 sq. ft.	SFR-Basic
99 103678 RK	R-9,600	Residential 9,600 sq. ft.	SFR-Basic
99 110765 RK	R-9,600	Residential 9,600 sq. ft.	SFR-Basic
99 103121 RK	R-9,600	Residential 9,600 sq. ft.	SFR-Basic
99 101991 RK	R-9,600	Residential 9,600 sq. ft.	SFR-Basic
99 101457 RK	R-9,600	Residential 9,600 sq. ft.	SFR-Basic
99 101274 RK	R-9,600	Residential 9,600 sq. ft.	SFR-Basic
99 101273 RK	R-9,600	Residential 9,600 sq. ft.	SFR-Basic
99 110303 RK	R-9,600	Residential 9,600 sq. ft.	SFR-Basic
99 105063 RK	R-9,600	Residential 9,600 sq. ft.	SFR-Basic
99 110352 RK	R-5	Rural-5 Acre	Single Family Res-Combo
99 110074 RK	R-5	Rural-5 Acre	Single Family Res-Combo
98 105719 MH	R-5	Rural-5 Acre	Double Wide
98 116180 RK	R-5	Rural-5 Acre	SFR-Basic
98 116936 RK	R-5	Rural-5 Acre	Single Family Res-Combo
99 101335 RK	F	Forestry	Single Family Res-Combo
99 112711 RK	R-5	Rural-5 Acre	Single Family Res-Combo
99 111906 RK	R-5	Rural-5 Acre	Single Family Res-Combo
99 111870 RK	R-5	Rural-5 Acre	Single Family Res-Combo
99 111935 RK	R-5	Rural-5 Acre	Single Family Res-Combo
99 103035 RK	R-5	Rural-5 Acre	Single Family Res-Combo
99 102381 RK	CITY	City	SFR-Basic
99 111841 RK	R-5	Rural-5 Acre	Single Family Res-Combo
99 100570 RK	R-5	Rural-5 Acre	Single Family Res-Combo
99 100197 RK	R-5	Rural-5 Acre	Single Family Res-Combo
99 100571 RK	R-5	Rural-5 Acre	Single Family Res-Combo
99 112594 RK	R-5	Rural-5 Acre	Single Family Res-Combo
99 109329 RK	R-9,600	Residential 9,600 sq. ft.	SFR-Basic
99 105283 MH	R-5	Rural-5 Acre	Triple Wide
98 107869 RK	R-5	Rural-5 Acre	Single Family Res-Combo
99 100121 RK	R-5	Rural-5 Acre	Single Family Res-Combo
99 103105 RK	R-5	Rural-5 Acre	Single Family Res-Combo
99 110526 RK	R-5	Rural-5 Acre	Single Family Res-Combo
98 150965 RK	F	Forestry	Single Family Res-Combo

Accessory Dwelling Units

Index # - File Name: 1.0022 - Single Family Dwellings Data\_Snohomish County.pdf

98 116880 RK	F : R-5	Forestry : Rural-5 Acre	Single Family Res-Combo
99 104849 RK	R-5	Rural-5 Acre	Single Family Res-Combo
99 104330 RK	R-5	Rural-5 Acre	Single Family Res-Combo
99 100140 RK	R-5	Rural-5 Acre	Single Family Res-Combo
99 102468 RK	R-5	Rural-5 Acre	Single Family Res-Combo
99 104353 RK	R-5	Rural-5 Acre	SFR-Basic
98 116937 RK	R-5	Rural-5 Acre	Single Family Res-Combo
99 110759 RK	R-5	Rural-5 Acre	Single Family Res-Combo
99 102121 RK	R-5	Rural-5 Acre	Single Family Res-Combo
98 110715 RK	R-5	Rural-5 Acre	Single Family Res-Combo
99 104911 RK	R-5	Rural-5 Acre	SFR-Basic
99 104913 RK	R-5	Rural-5 Acre	SFR-Basic
98 105843 RK	R-5	Rural-5 Acre	SFR-Basic
98 105842 RK	R-5	Rural-5 Acre	SFR-Basic
98 102753 MH	R-5	Rural-5 Acre	Double Wide
98 106421 RK	R-5	Rural-5 Acre	Single Family Res-Combo
99 112114 RK	R-5	Rural-5 Acre	Single Family Res-Combo
99 101507 RK	R-5	Rural-5 Acre	Single Family Res-Combo
98 109445 RK	R-7,200	Residential 7,200 sq. ft.	Single Family Res-Combo
99 100553 RK	R-5	Rural-5 Acre	Single Family Res-Combo
98 106441 RK	PRD SA-1	Suburban Agriculture-1 Acre	SFR-Basic
99 103464 RK	PRD SA-1	Suburban Agriculture-1 Acre	Single Family Res-Combo
99 104641 RK	PRD SA-1	Suburban Agriculture-1 Acre	Single Family Res-Combo
99 110150 RK	PRD SA-1	Suburban Agriculture-1 Acre	SFR-Basic
98 151157 RK	PRD SA-1	Suburban Agriculture-1 Acre	Single Family Res-Combo
99 102386 RK	PRD SA-1	Suburban Agriculture-1 Acre	Single Family Res-Combo
98 109510 RK	PRD SA-1	Suburban Agriculture-1 Acre	Single Family Res-Combo
99 103547 RK	PRD SA-1	Suburban Agriculture-1 Acre	Single Family Res-Combo
98 116140 RK	R-5	Rural-5 Acre	Single Family Res-Combo
99 101685 RK	PRD SA-1	Suburban Agriculture-1 Acre	Single Family Res-Combo
99 112209 RK	R-5	Rural-5 Acre	Single Family Res-Combo
99 104345 RK	PRD SA-1	Suburban Agriculture-1 Acre	Single Family Res-Combo
99 109332 RK	PRD SA-1	Suburban Agriculture-1 Acre	SFR-Basic
99 110417 RK	PRD SA-1	Suburban Agriculture-1 Acre	SFR-Basic
98 105024 RK	PRD SA-1	Suburban Agriculture-1 Acre	Single Family Res-Combo
99 109527 RK	R-5	Rural-5 Acre	Single Family Res-Combo
99 103668 RK	R-5	Rural-5 Acre	Single Family Res-Combo
98 151024 RK	R-5	Rural-5 Acre	Single Family Res-Combo
99 100275 RK	R-5	Rural-5 Acre	Single Family Res-Combo
99 112407 RK	R-5	Rural-5 Acre	Single Family Res-Combo
98 150801 RK	R-5	Rural-5 Acre	Single Family Res-Combo
98 102673 RK	R-5	Rural-5 Acre	Single Family Res-Combo
99 112660 RK	R-5	Rural-5 Acre	SFR-Basic
98 100791 RK	R-7,200	Residential 7,200 sq. ft.	Single Family Res-Combo
98 109820 RK	R-5	Rural-5 Acre	Single Family Res-Combo
99 110159 MH	LDMR	Low Density Multiple Reside	Double Wide
98 106725 RK	R-5	Rural-5 Acre	Single Family Res-Combo

Accessory Dwelling Units

Index # - File Name: 1.0022 - Single Family Dwellings Data\_Snohomish County.pdf

99 101916 RK	R-5	Rural-5 Acre	Single Family Res-Combo
99 114551 RK	R-5	Rural-5 Acre	Single Family Res-Combo
98 116118 RK	R-5	Rural-5 Acre	Single Family Res-Combo
98 110012 RK	R-5	Rural-5 Acre	Single Family Res-Combo
99 103819 RK	R-5	Rural-5 Acre	Single Family Res-Combo
99 100248 RK	R-5	Rural-5 Acre	Single Family Res-Combo
99 104529 RK	R-5	Rural-5 Acre	Single Family Res-Combo
99 102097 RK	R-9,600	Residential 9,600 sq. ft.	Single Family Res-Combo
99 100236 RK	RD	Rural Diversification	Single Family Res-Combo
99 100504 RK	R-9,600	Residential 9,600 sq. ft.	Single Family Res-Combo
99 113512 MH	R-5	Rural-5 Acre	Double Wide
99 114423 RK	R-5	Rural-5 Acre	Single Family Res-Combo
99 101780 RK	R-5	Rural-5 Acre	Single Family Res-Combo
98 106813 RK	R-5	Rural-5 Acre	Single Family Res-Combo
99 109856 RK	R-5	Rural-5 Acre	Single Family Res-Combo
99 109795 RK	R-5	Rural-5 Acre	Single Family Res-Combo
99 102336 RK	R-5	Rural-5 Acre	SFR-Basic
99 101448 RK	R-9,600	Residential 9,600 sq. ft.	Single Family Res-Combo
97 111140 RK	R-5	Rural-5 Acre	Single Family Res-Combo
98 116290 RK	R-5	Rural-5 Acre	Single Family Res-Combo
98 116811 RK	R-5	Rural-5 Acre	Single Family Res-Combo
98 150665 RK	R-5	Rural-5 Acre	Single Family Res-Combo
98 116053 RK	R-5	Rural-5 Acre	Single Family Res-Combo
98 109936 RK	R-5	Rural-5 Acre	Single Family Res-Combo
99 101551 RK	R-5	Rural-5 Acre	Single Family Res-Combo
98 104807 RK	R-5	Rural-5 Acre	Single Family Res-Combo
99 103768 RK	R-5	Rural-5 Acre	Single Family Res-Combo
97 111385 MH	R-5	Rural-5 Acre	Triple Wide
98 150987 RK	R-5	Rural-5 Acre	Single Family Res-Combo
99 103274 RK	R-5	Rural-5 Acre	Single Family Res-Combo
99 104879 RK	R-5	Rural-5 Acre	Single Family Res-Combo
99 114547 RK	RRT-10	Rural Resource Transition-1	Single Family Res-Combo
98 110157 RK	PRD-LDMR	Low Density Multiple Reside	SFR-Basic
98 110158 RK	PRD-LDMR	Low Density Multiple Reside	SFR-Basic
98 110151 RK	PRD-LDMR	Low Density Multiple Reside	SFR-Basic
98 110153 RK	PRD-LDMR	Low Density Multiple Reside	SFR-Basic
98 108868 RK	PRD-LDMR	Low Density Multiple Reside	Single Family Res-Combo
99 100195 RK	PRD-7,200	Residential 7,200 sq. ft.	SFR-Basic
99 104421 RK	PRD-7,200	Residential 7,200 sq. ft.	SFR-Basic
99 105270 RK	PRD-7,200	Residential 7,200 sq. ft.	SFR-Basic
99 100190 RK	PRD-7,200	Residential 7,200 sq. ft.	SFR-Basic
99 105273 RK	PRD-7,200	Residential 7,200 sq. ft.	SFR-Basic
99 103054 RK	PRD-7,200	Residential 7,200 sq. ft.	SFR-Basic
99 103614 RK	PRD-7,200	Residential 7,200 sq. ft.	Single Family Res-Combo
99 103801 RK	PRD-7,200	Residential 7,200 sq. ft.	SFR-Basic
99 104783 RK	PRD-7,200	Residential 7,200 sq. ft.	SFR-Basic
99 110313 RK	PRD-7,200	Residential 7,200 sq. ft.	SFR-Basic



Accessory Dwelling Units

Index # - File Name: 1.0022 - Single Family Dwellings Data\_Snohomish County.pdf

99 103952 RK	PRD-7,200	Residential 7,200 sq. ft.	SFR-Basic
99 103950 RK	PRD-7,200	Residential 7,200 sq. ft.	SFR-Basic
99 104423 RK	PRD-7,200	Residential 7,200 sq. ft.	SFR-Basic
98 109412 RK	R-5	Rural-5 Acre	Accessory Apt Detached-Combo
99 105041 RK	R-5	Rural-5 Acre	Single Family Res-Combo
99 100459 MH	F	Forestry	Double Wide
99 110117 RK	R-5	Rural-5 Acre	Single Family Res-Combo
98 151017 RK	R-5	Rural-5 Acre	SFR-Basic
99 101418 RK	R-7,200	Residential 7,200 sq. ft.	Single Family Res-Combo
99 105069 RK	R-7,200	Residential 7,200 sq. ft.	Single Family Res-Combo
99 101419 RK	R-7,200	Residential 7,200 sq. ft.	Single Family Res-Combo
99 105064 RK	R-7,200	Residential 7,200 sq. ft.	Single Family Res-Combo
99 101325 RK	PRD-9,600	Residential 9,600 sq. ft.	SFR-Basic
99 110834 RK	PRD-9,600	Residential 9,600 sq. ft.	SFR-Basic
99 113097 RK	PRD-9,600	Residential 9,600 sq. ft.	SFR-Basic
99 113100 RK	PRD-9,600	Residential 9,600 sq. ft.	SFR-Basic
98 150887 RK	PRD-9,600	Residential 9,600 sq. ft.	SFR-Basic
98 150886 RK	PRD-9,600	Residential 9,600 sq. ft.	SFR-Basic
99 101567 RK	PRD-9,600	Residential 9,600 sq. ft.	SFR-Basic
99 102725 RK	PRD-9,600	Residential 9,600 sq. ft.	SFR-Basic
99 113099 RK	PRD-9,600	Residential 9,600 sq. ft.	SFR-Basic
99 113102 RK	PRD-9,600	Residential 9,600 sq. ft.	SFR-Basic
99 102448 RK	PRD-9,600	Residential 9,600 sq. ft.	SFR-Basic
99 101326 RK	PRD-9,600	Residential 9,600 sq. ft.	SFR-Basic
99 102729 RK	PRD-9,600	Residential 9,600 sq. ft.	SFR-Basic
99 101327 RK	PRD-9,600	Residential 9,600 sq. ft.	SFR-Basic
99 101328 RK	PRD-9,600	Residential 9,600 sq. ft.	SFR-Basic
99 103392 RK	PRD-9,600	Residential 9,600 sq. ft.	SFR-Basic
99 103395 RK	PRD-9,600	Residential 9,600 sq. ft.	SFR-Basic
99 102452 RK	PRD-9,600	Residential 9,600 sq. ft.	SFR-Basic
99 102728 RK	PRD-9,600	Residential 9,600 sq. ft.	SFR-Basic
99 103398 RK	PRD-9,600	Residential 9,600 sq. ft.	SFR-Basic
99 103399 RK	PRD-9,600	Residential 9,600 sq. ft.	SFR-Basic
99 102726 RK	PRD-9,600	Residential 9,600 sq. ft.	SFR-Basic
99 103396 RK	PRD-9,600	Residential 9,600 sq. ft.	SFR-Basic
99 103400 RK	PRD-9,600	Residential 9,600 sq. ft.	SFR-Basic
99 103397 RK	PRD-9,600	Residential 9,600 sq. ft.	SFR-Basic
99 103394 RK	PRD-9,600	Residential 9,600 sq. ft.	SFR-Basic
99 103401 RK	PRD-9,600	Residential 9,600 sq. ft.	SFR-Basic
98 110191 RK	R-5	Rural-5 Acre	Single Family Res-Combo
98 116599 RK	R-5	Rural-5 Acre	Single Family Res-Combo
98 116926 RK	R-7,200	Residential 7,200 sq. ft.	SFR-Basic
99 102130 RK	R-7,200	Residential 7,200 sq. ft.	Single Family Res-Combo
98 109397 MH	F	Forestry	Double Wide
99 105074 RK	R-5	Rural-5 Acre	Single Family Res-Combo
98 116931 RK	R-7,200	Residential 7,200 sq. ft.	SFR-Basic
98 116927 RK	R-7,200	Residential 7,200 sq. ft.	SFR-Basic

Accessory Dwelling Units

Index # - File Name: 1.0022 - Single Family Dwellings Data\_Snohomish County.pdf

99 110581 MH	R-5	Rural-5 Acre	Double Wide
99 110542 RK	R-5	Rural-5 Acre	Single Family Res-Combo
98 150721 RK	R-5	Rural-5 Acre	Single Family Res-Combo
99 100605 RK	R-5	Rural-5 Acre	Single Family Res-Combo
99 109371 RK	CITY	City	Duplex-Combo
98 151139 RK	RD	Rural Diversification	Single Family Res-Combo
99 101556 RK	CITY	City	Single Family Res-Combo
99 105205 RK	R-7,200	Residential 7,200 sq. ft.	SFR-Basic
98 108782 RK	R-5	Rural-5 Acre	Single Family Res-Combo
99 109509 RK	R-9,600	Residential 9,600 sq. ft.	SFR-Basic
99 102137 RK	R-9,600	Residential 9,600 sq. ft.	SFR-Basic
98 108101 RK	R-9,600	Residential 9,600 sq. ft.	Single Family Res-Combo
98 108403 RK	R-9,600	Residential 9,600 sq. ft.	Single Family Res-Combo
99 100463 RK	R-9,600	Residential 9,600 sq. ft.	Single Family Res-Combo
99 101398 RK	R-9,600	Residential 9,600 sq. ft.	SFR-Basic
99 100343 RK	R-9,600	Residential 9,600 sq. ft.	SFR-Basic
99 103254 RK	R-9,600	Residential 9,600 sq. ft.	SFR-Basic
99 102138 RK	R-9,600	Residential 9,600 sq. ft.	SFR-Basic
99 110096 RK	R-9,600	Residential 9,600 sq. ft.	SFR-Basic
98 116274 RK	CITY	City	Single Family Res-Combo
98 150491 MH	R-5	Rural-5 Acre	Double Wide
99 110102 RK	CITY	City	Single Family Res-Combo
97 111452 RK	CITY	City	Single Family Res-Combo
99 100998 RK	R-7,200	Residential 7,200 sq. ft.	SFR-Basic
99 100994 RK	R-7,200	Residential 7,200 sq. ft.	SFR-Basic
99 114701 RK	R-7,200	Residential 7,200 sq. ft.	Single Family Res-Combo
99 102436 RK	R-7,200	Residential 7,200 sq. ft.	SFR-Basic
99 101407 RK	R-7,200	Residential 7,200 sq. ft.	Single Family Res-Combo
99 103213 RK	R-7,200	Residential 7,200 sq. ft.	SFR-Basic
99 102430 RK	R-7,200	Residential 7,200 sq. ft.	SFR-Basic
99 103463 RK	R-5	Rural-5 Acre	Single Family Res-Combo
99 111055 RK	R-7,200	Residential 7,200 sq. ft.	Single Family Res-Combo
99 113581 RK	R-7,200	Residential 7,200 sq. ft.	Single Family Res-Combo
99 101400 RK	R-7,200	Residential 7,200 sq. ft.	Single Family Res-Combo
99 102835 MH	F	Forestry	Single Wide
98 108191 RK	R-5	Rural-5 Acre	Single Family Res-Combo
99 102771 RK	R-5	Rural-5 Acre	Single Family Res-Combo
98 110226 RK	R-8,400	Residential 8,400 sq. ft.	Single Family Res-Combo
98 150817 RK	R-5	Rural-5 Acre	Single Family Res-Combo
98 150828 RK	T	Townhouse	SFR-Basic
99 111062 MH	R-5	Rural-5 Acre	Double Wide
99 109925 RK	CITY	City	SFR-Basic
99 103375 RK	CITY	City	SFR-Basic
99 103141 RK	CITY	City	SFR-Basic
99 103143 RK	CITY	City	SFR-Basic
99 104383 RK	F	Forestry	Single Family Res-Combo
99 103376 RK	CITY	City	SFR-Basic

Accessory Dwelling Units

Index # - File Name: 1.0022 - Single Family Dwellings Data\_Snohomish County.pdf

99 103377 RK	CITY	City	SFR-Basic
99 100347 RK	CITY	City	SFR-Basic
99 100349 RK	CITY	City	SFR-Basic
98 150450 RK	CITY	City	SFR-Basic
99 104243 RK	CITY	City	SFR-Basic
99 104453 RK	CITY	City	SFR-Basic
99 109930 RK	CITY	City	SFR-Basic
99 104242 RK	CITY	City	SFR-Basic
99 101877 RK	CITY	City	SFR-Basic
99 101876 RK	CITY	City	SFR-Basic
99 104449 RK	CITY	City	SFR-Basic
99 101600 RK	CITY	City	SFR-Basic
99 109924 RK	CITY	City	SFR-Basic
99 101599 RK	CITY	City	SFR-Basic
99 101347 RK	CITY	City	SFR-Basic
99 101598 RK	CITY	City	SFR-Basic
99 101595 RK	CITY	City	SFR-Basic
98 116821 RK	CITY	City	SFR-Basic
99 101875 RK	CITY	City	SFR-Basic
99 101349 RK	CITY	City	SFR-Basic
99 104240 RK	CITY	City	SFR-Basic
99 101601 RK	CITY	City	SFR-Basic
99 101596 RK	CITY	City	SFR-Basic
99 101344 RK	CITY	City	Single Family Res-Combo
99 101592 RK	CITY	City	SFR-Basic
99 100997 RK	CITY	City	SFR-Basic
98 116521 RK	CITY	City	Single Family Res-Combo
98 150449 RK	CITY	City	SFR-Basic
99 104448 RK	CITY	City	SFR-Basic
99 102328 RK	CITY	City	Single Family Res-Combo
99 102324 RK	CITY	City	Single Family Res-Combo
99 102331 RK	CITY	City	Single Family Res-Combo
99 100871 RK	CITY	City	SFR-Basic
99 100866 RK	CITY	City	SFR-Basic
99 101803 RK	CITY	City	SFR-Basic
99 101804 RK	CITY	City	SFR-Basic
99 100868 RK	CITY	City	SFR-Basic
99 100163 RK	CITY	City	SFR-Basic
99 100876 RK	CITY	City	SFR-Basic
99 101806 RK	CITY	City	SFR-Basic
99 100884 RK	CITY	City	SFR-Basic
99 101787 RK	CITY	City	SFR-Basic
99 101801 RK	CITY	City	SFR-Basic
99 100995 RK	CITY	City	SFR-Basic
99 100992 RK	CITY	City	Single Family Res-Combo
99 101003 RK	CITY	City	SFR-Basic
99 100993 RK	CITY	City	SFR-Basic

Accessory Dwelling Units

Index # - File Name: 1.0022 - Single Family Dwellings Data\_Snohomish County.pdf

99 103840 RK	F	Forestry	Single Family Res-Combo
98 150517 RK	PRD-9,600	Residential 9,600 sq. ft.	SFR-Basic
99 101530 RK	CITY	City	SFR-Basic
99 101532 RK	CITY	City	SFR-Basic
98 150519 RK	PRD-9,600	Residential 9,600 sq. ft.	SFR-Basic
99 102846 RK	PRD-9,600	Residential 9,600 sq. ft.	SFR-Basic
99 104857 RK	R-5	Rural-5 Acre	Single Family Res-Combo
98 150977 RK	CITY	City	Duplex-Combo
99 101468 RK	PRD-9,600	Residential 9,600 sq. ft.	SFR-Basic
99 101042 RK	PRD-9,600	Residential 9,600 sq. ft.	SFR-Basic
99 109326 RK	R-9,600	Residential 9,600 sq. ft.	Single Family Res-Combo
99 109331 RK	R-9,600	Residential 9,600 sq. ft.	SFR-Basic
98 108542 RK	R-5	Rural-5 Acre	Single Family Res-Combo
98 100938 RK	MR	Multiple Residential	Duplex-Combo
98 106459 RK	MR	Multiple Residential	Duplex-Basic
98 106460 RK	MR	Multiple Residential	Duplex-Basic
98 106461 RK	MR	Multiple Residential	Duplex-Basic
98 106462 RK	MR	Multiple Residential	Duplex-Basic
98 150531 RK	R-5	Rural-5 Acre	Single Family Res-Combo
99 113384 RK	R-5	Rural-5 Acre	Single Family Res-Combo
98 150957 RK	PRD-9,600	Residential 9,600 sq. ft.	SFR-Basic
99 112640 RK	MR	Multiple Residential	Single Family Res-Combo
99 102885 RK	R-7,200	Residential 7,200 sq. ft.	SFR-Basic
98 116574 RK	R-7,200	Residential 7,200 sq. ft.	Single Family Res-Combo
99 109672 RK	R-7,200	Residential 7,200 sq. ft.	SFR-Basic
98 116575 RK	R-7,200	Residential 7,200 sq. ft.	Single Family Res-Combo
99 103235 RK	R-7,200	Residential 7,200 sq. ft.	Single Family Res-Combo
98 151047 RK	R-7,200	Residential 7,200 sq. ft.	SFR-Basic
98 151026 RK	RD	Rural Diversification	Single Family Res-Combo
99 101479 RK	R-7,200	Residential 7,200 sq. ft.	Single Family Res-Combo
99 101478 RK	R-7,200	Residential 7,200 sq. ft.	SFR-Basic
99 101480 RK	R-7,200	Residential 7,200 sq. ft.	Single Family Res-Combo
99 113719 RK	R-7,200	Residential 7,200 sq. ft.	Single Family Res-Combo
99 101463 RK	R-5	Rural-5 Acre	Single Family Res-Combo
99 101900 RK	R-5	Rural-5 Acre	Single Family Res-Combo
99 101902 RK	R-5	Rural-5 Acre	Single Family Res-Combo
99 101906 RK	R-5	Rural-5 Acre	Single Family Res-Combo
99 100141 MH	R-5	Rural-5 Acre	Triple Wide
99 100143 MH	R-5	Rural-5 Acre	Double Wide
99 111583 RK	R-5	Rural-5 Acre	Single Family Res-Combo
98 108763 RK	PRD-9,600	Residential 9,600 sq. ft.	Single Family Res-Combo
98 108764 RK	PRD-9,600	Residential 9,600 sq. ft.	Single Family Res-Combo
98 150668 RK	PRD-9,600	Residential 9,600 sq. ft.	SFR-Basic
98 150670 RK	PRD-9,600	Residential 9,600 sq. ft.	SFR-Basic
98 150832 RK	PRD-9,600	Residential 9,600 sq. ft.	SFR-Basic
98 150833 RK	PRD-9,600	Residential 9,600 sq. ft.	SFR-Basic
99 109559 RK	SA-1	Suburban Agriculture-1 Acre	Single Family Res-Combo

Accessory Dwelling Units

Index # - File Name: 1.0022 - Single Family Dwellings Data\_Snohomish County.pdf

98 150773 RK	RRT-10	Rural Resource Transition-10	Single Family Res-Combo
99 103528 RK	R-20,000	Residential 20,000 sq. ft.	Single Family Res-Combo
98 150933 RK	R-7,200	Residential 7,200 sq. ft.	Single Family Res-Combo
99 109537 RK	R-5	Rural-5 Acre	Single Family Res-Combo
99 101999 MH	R-5	Rural-5 Acre	Double Wide
98 116572 RK	R-7,200	Residential 7,200 sq. ft.	Single Family Res-Combo
99 100312 RK	R-7,200	Residential 7,200 sq. ft.	SFR-Basic
99 100579 RK	R-7,200	Residential 7,200 sq. ft.	Single Family Res-Combo
99 101202 RK	R-7,200	Residential 7,200 sq. ft.	Single Family Res-Combo
99 109574 RK	R-7,200	Residential 7,200 sq. ft.	SFR-Basic
99 101276 RK	R-7,200	Residential 7,200 sq. ft.	Single Family Res-Combo
99 103412 RK	R-7,200	Residential 7,200 sq. ft.	Single Family Res-Combo
99 109573 RK	R-7,200	Residential 7,200 sq. ft.	SFR-Basic
99 103234 RK	R-7,200	Residential 7,200 sq. ft.	Single Family Res-Combo
99 104373 RK	R-7,200	Residential 7,200 sq. ft.	SFR-Basic
99 100319 RK	R-7,200	Residential 7,200 sq. ft.	SFR-Basic
99 101688 RK	R-7,200	Residential 7,200 sq. ft.	Single Family Res-Combo
99 113185 RK	R-7,200	Residential 7,200 sq. ft.	SFR-Basic
99 100313 RK	R-7,200	Residential 7,200 sq. ft.	SFR-Basic
99 100315 RK	R-7,200	Residential 7,200 sq. ft.	SFR-Basic
99 100316 RK	R-7,200	Residential 7,200 sq. ft.	SFR-Basic
99 101831 RK	PRD-9,600	Residential 9,600 sq. ft.	SFR-Basic
99 101833 RK	PRD-9,600	Residential 9,600 sq. ft.	SFR-Basic
99 101834 RK	PRD-9,600	Residential 9,600 sq. ft.	SFR-Basic
99 101835 RK	PRD-9,600	Residential 9,600 sq. ft.	SFR-Basic
99 101836 RK	PRD-9,600	Residential 9,600 sq. ft.	SFR-Basic
99 101837 RK	PRD-9,600	Residential 9,600 sq. ft.	SFR-Basic
99 101838 RK	PRD-9,600	Residential 9,600 sq. ft.	SFR-Basic
99 101840 RK	PRD-9,600	Residential 9,600 sq. ft.	SFR-Basic
99 101842 RK	PRD-9,600	Residential 9,600 sq. ft.	SFR-Basic
99 101843 RK	PRD-9,600	Residential 9,600 sq. ft.	SFR-Basic
99 101844 RK	PRD-9,600	Residential 9,600 sq. ft.	SFR-Basic
99 101845 RK	PRD-9,600	Residential 9,600 sq. ft.	SFR-Basic
99 101846 RK	PRD-9,600	Residential 9,600 sq. ft.	SFR-Basic
99 101847 RK	PRD-9,600	Residential 9,600 sq. ft.	SFR-Basic
99 101848 RK	PRD-9,600	Residential 9,600 sq. ft.	SFR-Basic
99 101849 RK	PRD-9,600	Residential 9,600 sq. ft.	SFR-Basic
99 101850 RK	PRD-9,600	Residential 9,600 sq. ft.	SFR-Basic
99 101851 RK	PRD-9,600	Residential 9,600 sq. ft.	SFR-Basic
99 101852 RK	PRD-9,600	Residential 9,600 sq. ft.	SFR-Basic
99 101853 RK	PRD-9,600	Residential 9,600 sq. ft.	SFR-Basic
99 101854 RK	PRD-9,600	Residential 9,600 sq. ft.	SFR-Basic
99 111926 RK	PRD-9,600	Residential 9,600 sq. ft.	SFR-Basic
99 111922 RK	PRD-9,600	Residential 9,600 sq. ft.	SFR-Basic
99 111925 RK	PRD-9,600	Residential 9,600 sq. ft.	SFR-Basic
99 111931 RK	PRD-9,600	Residential 9,600 sq. ft.	SFR-Basic
99 111924 RK	PRD-9,600	Residential 9,600 sq. ft.	SFR-Basic

Accessory Dwelling Units

Index # - File Name: 1.0022 - Single Family Dwellings Data\_Snohomish County.pdf

99 111930 RK	PRD-9,600	Residential 9,600 sq. ft.	SFR-Basic
99 111929 RK	PRD-9,600	Residential 9,600 sq. ft.	SFR-Basic
99 111923 RK	PRD-9,600	Residential 9,600 sq. ft.	SFR-Basic
99 111928 RK	PRD-9,600	Residential 9,600 sq. ft.	SFR-Basic
99 111927 RK	PRD-9,600	Residential 9,600 sq. ft.	SFR-Basic
99 112164 RK	PRD-9,600	Residential 9,600 sq. ft.	SFR-Basic
99 112156 RK	PRD-9,600	Residential 9,600 sq. ft.	SFR-Basic
99 112165 RK	PRD-9,600	Residential 9,600 sq. ft.	SFR-Basic
99 112166 RK	PRD-9,600	Residential 9,600 sq. ft.	SFR-Basic
99 112167 RK	PRD-9,600	Residential 9,600 sq. ft.	SFR-Basic
99 112168 RK	PRD-9,600	Residential 9,600 sq. ft.	SFR-Basic
99 112157 RK	PRD-9,600	Residential 9,600 sq. ft.	SFR-Basic
99 112169 RK	PRD-9,600	Residential 9,600 sq. ft.	SFR-Basic
99 112170 RK	PRD-9,600	Residential 9,600 sq. ft.	SFR-Basic
99 112171 RK	PRD-9,600	Residential 9,600 sq. ft.	SFR-Basic
99 112158 RK	PRD-9,600	Residential 9,600 sq. ft.	SFR-Basic
99 112172 RK	PRD-9,600	Residential 9,600 sq. ft.	SFR-Basic
99 114145 RK	PRD-9,600	Residential 9,600 sq. ft.	SFR-Basic
99 114147 RK	PRD-9,600	Residential 9,600 sq. ft.	SFR-Basic
99 101855 RK	PRD-9,600	Residential 9,600 sq. ft.	SFR-Basic
99 101856 RK	PRD-9,600	Residential 9,600 sq. ft.	SFR-Basic
99 101858 RK	PRD-9,600	Residential 9,600 sq. ft.	SFR-Basic
99 101859 RK	PRD-9,600	Residential 9,600 sq. ft.	SFR-Basic
99 101860 RK	PRD-9,600	Residential 9,600 sq. ft.	SFR-Basic
99 101861 RK	PRD-9,600	Residential 9,600 sq. ft.	SFR-Basic
99 101862 RK	PRD-9,600	Residential 9,600 sq. ft.	SFR-Basic
99 101863 RK	PRD-9,600	Residential 9,600 sq. ft.	SFR-Basic
99 101864 RK	PRD-9,600	Residential 9,600 sq. ft.	SFR-Basic
99 101866 RK	PRD-9,600	Residential 9,600 sq. ft.	SFR-Basic
99 112159 RK	PRD-9,600	Residential 9,600 sq. ft.	SFR-Basic
99 112173 RK	PRD-9,600	Residential 9,600 sq. ft.	SFR-Basic
99 112160 RK	PRD-9,600	Residential 9,600 sq. ft.	SFR-Basic
99 112174 RK	PRD-9,600	Residential 9,600 sq. ft.	SFR-Basic
99 112161 RK	PRD-9,600	Residential 9,600 sq. ft.	SFR-Basic
99 112175 RK	PRD-9,600	Residential 9,600 sq. ft.	SFR-Basic
99 112176 RK	PRD-9,600	Residential 9,600 sq. ft.	SFR-Basic
99 112162 RK	PRD-9,600	Residential 9,600 sq. ft.	SFR-Basic
99 112163 RK	PRD-9,600	Residential 9,600 sq. ft.	SFR-Basic
99 109394 MH	R-7,200	Residential 7,200 sq. ft.	Double Wide
99 115309 RK	PRD-9,600	Residential 9,600 sq. ft.	SFR-Basic
99 100621 RK	PRD-9,600	Residential 9,600 sq. ft.	SFR-Basic
99 104226 RK	PRD-9,600	Residential 9,600 sq. ft.	SFR-Basic
99 109824 MH	CITY	City	MH Park-Double Wide
99 113484 MH	CITY	City	MH Park-Double Wide
99 114920 RK	PRD-9,600	Residential 9,600 sq. ft.	SFR-Basic
99 104630 RK	PRD-9,600	Residential 9,600 sq. ft.	Single Family Res-Combo
99 112279 RK	PRD-9,600	Residential 9,600 sq. ft.	Single Family Res-Combo

Accessory Dwelling Units

Index # - File Name: 1.0022 - Single Family Dwellings Data\_Snohomish County.pdf

98 151150 RK	PRD-9,600	Residential 9,600 sq. ft.	SFR-Basic
99 112281 RK	PRD-9,600	Residential 9,600 sq. ft.	Single Family Res-Combo
99 114089 RK	PRD-9,600	Residential 9,600 sq. ft.	SFR-Basic
98 116985 RK	PRD-9,600	Residential 9,600 sq. ft.	Single Family Res-Combo
99 112094 RK	PRD-9,600	Residential 9,600 sq. ft.	Single Family Res-Combo
99 112361 RK	PRD-9,600	Residential 9,600 sq. ft.	SFR-Basic
99 114656 RK	PRD-9,600	Residential 9,600 sq. ft.	SFR-Basic
99 110872 RK	PRD-9,600	Residential 9,600 sq. ft.	SFR-Basic
98 151151 RK	PRD-9,600	Residential 9,600 sq. ft.	SFR-Basic
99 101559 RK	PRD-9,600	Residential 9,600 sq. ft.	Single Family Res-Combo
99 100585 RK	PRD-9,600	Residential 9,600 sq. ft.	Single Family Res-Combo
99 105354 RK	PRD-9,600	Residential 9,600 sq. ft.	SFR-Basic
98 151032 RK	PRD-9,600	Residential 9,600 sq. ft.	Single Family Res-Combo
99 104508 RK	PRD-9,600	Residential 9,600 sq. ft.	Single Family Res-Combo
99 110431 RK	PRD-9,600	Residential 9,600 sq. ft.	SFR-Basic
99 114085 RK	PRD-9,600	Residential 9,600 sq. ft.	SFR-Basic
99 113361 RK	PRD-9,600	Residential 9,600 sq. ft.	Single Family Res-Combo
99 110851 RK	PRD-9,600	Residential 9,600 sq. ft.	Single Family Res-Combo
99 103043 RK	PRD-9,600	Residential 9,600 sq. ft.	Single Family Res-Combo
99 103040 RK	PRD-9,600	Residential 9,600 sq. ft.	Single Family Res-Combo
99 115240 RK	PRD-9,600	Residential 9,600 sq. ft.	SFR-Basic
99 116137 MH	CITY	City	MH Park-Double Wide
99 114082 MH	CITY	City	MH Park-Double Wide
99 115351 MH	CITY	City	MH Park-Double Wide
99 110984 MH	CITY	City	MH Park-Double Wide
99 110491 MH	CITY	City	MH Park-Double Wide
99 113876 MH	CITY	City	MH Park-Double Wide
99 114883 MH	CITY	City	MH Park-Triple Wide
99 114227 MH	CITY	City	MH Park-Double Wide
99 109826 MH	CITY	City	MH Park-Double Wide
99 112604 MH	CITY	City	MH Park-Double Wide
99 110938 MH	CITY	City	MH Park-Double Wide
99 111965 MH	CITY	City	MH Park-Double Wide
99 115319 MH	CITY	City	MH Park-Double Wide
99 115011 MH	CITY	City	MH Park-Double Wide
99 113875 MH	CITY	City	MH Park-Double Wide
99 114096 MH	CITY	City	MH Park-Double Wide
99 109938 MH	CITY	City	MH Park-Double Wide
99 110389 MH	CITY	City	MH Park-Double Wide
99 113188 MH	CITY	City	MH Park-Double Wide
99 112291 MH	CITY	City	MH Park-Double Wide
99 111482 MH	CITY	City	MH Park-Double Wide
99 109880 MH	CITY	City	MH Park-Double Wide
99 109984 MH	CITY	City	Triple Wide
99 109970 MH	CITY	City	MH Park-Triple Wide
99 109934 MH	CITY	City	MH Park-Double Wide
99 115415 MH	CITY	City	MH Park-Double Wide

Accessory Dwelling Units

Index # - File Name: 1.0022 - Single Family Dwellings Data\_Snohomish County.pdf

99 110755 MH	CITY	City	Triple Wide
99 116145 MH	CITY	City	MH Park-Double Wide
98 150761 RK	R-5	Rural-5 Acre	Single Family Res-Combo
99 105337 RK	PRD-9,600	Residential 9,600 sq. ft.	Single Family Res-Combo
99 113175 RK	PRD-9,600	Residential 9,600 sq. ft.	Single Family Res-Combo
99 113158 RK	PRD-9,600	Residential 9,600 sq. ft.	Single Family Res-Combo
99 109294 RK	PRD-9,600	Residential 9,600 sq. ft.	SFR-Basic
99 115546 RK	PRD-9,600	Residential 9,600 sq. ft.	SFR-Basic
99 100124 RK	PRD-9,600	Residential 9,600 sq. ft.	SFR-Basic
99 100125 RK	PRD-9,600	Residential 9,600 sq. ft.	SFR-Basic
98 116984 RK	PRD-9,600	Residential 9,600 sq. ft.	Single Family Res-Combo
99 113183 RK	PRD-9,600	Residential 9,600 sq. ft.	Single Family Res-Combo
99 103380 RK	PRD-9,600	Residential 9,600 sq. ft.	SFR-Basic
99 113702 RK	PRD-9,600	Residential 9,600 sq. ft.	Single Family Res-Combo
99 113705 RK	PRD-9,600	Residential 9,600 sq. ft.	Single Family Res-Combo
99 113187 RK	PRD-9,600	Residential 9,600 sq. ft.	Single Family Res-Combo
99 115460 RK	PRD-9,600	Residential 9,600 sq. ft.	SFR-Basic
99 110428 RK	PRD-9,600	Residential 9,600 sq. ft.	SFR-Basic
98 116980 RK	PRD-9,600	Residential 9,600 sq. ft.	Single Family Res-Combo
99 104679 RK	PRD-9,600	Residential 9,600 sq. ft.	SFR-Basic
99 104676 RK	PRD-9,600	Residential 9,600 sq. ft.	Single Family Res-Combo
99 104678 RK	PRD-9,600	Residential 9,600 sq. ft.	SFR-Basic
99 113247 RK	PRD-9,600	Residential 9,600 sq. ft.	SFR-Basic
99 104230 RK	PRD-9,600	Residential 9,600 sq. ft.	Single Family Res-Combo
99 101604 RK	PRD-9,600	Residential 9,600 sq. ft.	Single Family Res-Combo
98 150884 RK	PRD-9,600	Residential 9,600 sq. ft.	Single Family Res-Combo
98 150888 RK	PRD-9,600	Residential 9,600 sq. ft.	Single Family Res-Combo
99 110429 RK	PRD-9,600	Residential 9,600 sq. ft.	SFR-Basic
99 105335 RK	PRD-9,600	Residential 9,600 sq. ft.	Single Family Res-Combo
98 108317 RK	PRD-9,600	Residential 9,600 sq. ft.	Single Family Res-Combo
99 100617 RK	PRD-9,600	Residential 9,600 sq. ft.	SFR-Basic
98 108017 RK	PRD-9,600	Residential 9,600 sq. ft.	Single Family Res-Combo
99 103806 RK	CITY	City	Duplex-Combo
99 104654 RK	CITY	City	Duplex-Combo
98 151000 MH	CITY	City	MH Park-Triple Wide
99 102004 MH	CITY	City	MH Park-Triple Wide
99 100943 MH	CITY	City	MH Park-Double Wide
99 101287 MH	CITY	City	MH Park-Double Wide
99 101021 MH	CITY	City	MH Park-Double Wide
99 101176 MH	CITY	City	MH Park-Triple Wide
99 104037 MH	CITY	City	MH Park-Double Wide
99 112831 MH	CITY	City	MH Park-Double Wide
99 104960 MH	CITY	City	MH Park-Double Wide
99 101373 MH	CITY	City	MH Park-Double Wide
99 100945 MH	CITY	City	MH Park-Double Wide
99 100246 MH	CITY	City	MH Park-Double Wide
99 103645 MH	CITY	City	MH Park-Double Wide



Accessory Dwelling Units

Index # - File Name: 1.0022 - Single Family Dwellings Data\_Snohomish County.pdf

99 102724 MH	CITY	City	MH Park-Double Wide
99 100247 MH	CITY	City	MH Park-Double Wide
99 101573 MH	CITY	City	MH Park-Double Wide
99 101189 MH	CITY	City	MH Park-Double Wide
99 100942 MH	CITY	City	MH Park-Double Wide
99 102826 MH	CITY	City	MH Park-Double Wide
99 110577 MH	CITY	City	MH Park-Double Wide
99 101536 MH	CITY	City	MH Park-Double Wide
99 101501 MH	CITY	City	MH Park-Double Wide
99 101640 MH	CITY	City	MH Park-Double Wide
99 101187 MH	CITY	City	MH Park-Double Wide
99 103402 MH	CITY	City	Double Wide
99 109325 MH	CITY	City	Double Wide
99 103824 MH	CITY	City	MH Park-Double Wide
99 104520 MH	CITY	City	MH Park-Double Wide
99 103689 MH	CITY	City	MH Park-Double Wide
99 103775 MH	CITY	City	MH Park-Double Wide
99 103260 MH	CITY	City	MH Park-Double Wide
99 102361 MH	CITY	City	MH Park-Double Wide
99 101641 MH	CITY	City	MH Park-Double Wide
99 103527 MH	CITY	City	MH Park-Double Wide
99 104798 MH	CITY	City	MH Park-Double Wide
99 104485 MH	CITY	City	MH Park-Double Wide
99 109619 MH	CITY	City	MH Park-Double Wide
99 104403 MH	CITY	City	MH Park-Double Wide
99 101619 MH	CITY	City	MH Park-Double Wide
99 105290 MH	CITY	City	MH Park-Double Wide
99 103603 MH	CITY	City	MH Park-Double Wide
99 104424 MH	CITY	City	MH Park-Double Wide
99 100944 MH	CITY	City	MH Park-Double Wide
99 100249 MH	CITY	City	MH Park-Double Wide
98 150973 RK	PRD-9,600	Residential 9,600 sq. ft.	SFR-Basic
99 104225 RK	PRD-9,600	Residential 9,600 sq. ft.	SFR-Basic
98 150594 RK	PRD-9,600	Residential 9,600 sq. ft.	Single Family Res-Combo
99 109494 RK	PRD-9,600	Residential 9,600 sq. ft.	SFR-Basic
98 150975 RK	PRD-9,600	Residential 9,600 sq. ft.	SFR-Basic
98 108517 RK	PRD-9,600	Residential 9,600 sq. ft.	Single Family Res-Combo
98 150492 RK	R-5	Rural-5 Acre	SFR-Basic
99 100226 RK	PRD-9,600	Residential 9,600 sq. ft.	Single Family Res-Combo
98 150583 RK	PRD-9,600	Residential 9,600 sq. ft.	Single Family Res-Combo
98 150580 RK	PRD-9,600	Residential 9,600 sq. ft.	Single Family Res-Combo
99 100220 RK	PRD-9,600	Residential 9,600 sq. ft.	Single Family Res-Combo
99 112846 RK	PRD-9,600	Residential 9,600 sq. ft.	Single Family Res-Combo
99 100612 RK	PRD-9,600	Residential 9,600 sq. ft.	SFR-Basic
98 151149 RK	PRD-9,600	Residential 9,600 sq. ft.	SFR-Basic
99 104681 RK	PRD-9,600	Residential 9,600 sq. ft.	SFR-Basic
98 150976 RK	PRD-9,600	Residential 9,600 sq. ft.	Single Family Res-Combo

Accessory Dwelling Units

Index # - File Name: 1.0022 - Single Family Dwellings Data\_Snohomish County.pdf

98 108516 RK	PRD-9,600	Residential 9,600 sq. ft.	Single Family Res-Combo
98 117013 RK	PRD-9,600	Residential 9,600 sq. ft.	Single Family Res-Combo
98 150986 RK	PRD-9,600	Residential 9,600 sq. ft.	Single Family Res-Combo
98 150815 RK	PRD-9,600	Residential 9,600 sq. ft.	Single Family Res-Combo
99 100426 RK	PRD-9,600	Residential 9,600 sq. ft.	Single Family Res-Combo
99 109548 RK	PRD-9,600	Residential 9,600 sq. ft.	Single Family Res-Combo
99 109486 RK	PRD-9,600	Residential 9,600 sq. ft.	Single Family Res-Combo
98 151033 RK	PRD-9,600	Residential 9,600 sq. ft.	Single Family Res-Combo
98 151035 RK	PRD-9,600	Residential 9,600 sq. ft.	Single Family Res-Combo
99 103207 RK	PRD-9,600	Residential 9,600 sq. ft.	Single Family Res-Combo
99 110085 RK	PRD-9,600	Residential 9,600 sq. ft.	SFR-Basic
98 117015 RK	R-5	Rural-5 Acre	Single Family Res-Combo
98 116286 RK	R-5	Rural-5 Acre	Single Family Res-Combo
98 116558 MH	R-5	Rural-5 Acre	Single Wide
98 150453 RK	CITY	City	SFR-Basic
98 150472 RK	R-5	Rural-5 Acre	Single Family Res-Combo
98 150473 RK	R-5	Rural-5 Acre	Single Family Res-Combo
99 112923 RK	R-5	Rural-5 Acre	Single Family Res-Combo
98 150497 MH	R-5	Rural-5 Acre	Single Wide
98 150485 RK	LDMR : R-9,60	Low Density Multiple Reside	Duplex-Combo
98 150486 RK	LDMR	Low Density Multiple Reside	Duplex-Combo
99 110433 RK	PRD-9,600	Residential 9,600 sq. ft.	SFR-Basic
99 113372 RK	PRD-9,600	Residential 9,600 sq. ft.	SFR-Basic
99 101807 RK	PRD-9,600	Residential 9,600 sq. ft.	SFR-Basic
99 104218 RK	PRD-9,600	Residential 9,600 sq. ft.	SFR-Basic
99 100613 RK	PRD-9,600	Residential 9,600 sq. ft.	SFR-Basic
99 109798 RK	CITY	City	SFR-Basic
99 109799 RK	CITY	City	SFR-Basic
99 113277 RK	CITY	City	SFR-Basic
99 113278 RK	CITY	City	SFR-Basic
99 113280 RK	CITY	City	SFR-Basic
99 103280 RK	CITY	City	SFR-Basic
99 103282 RK	CITY	City	SFR-Basic
99 103283 RK	CITY	City	SFR-Basic
99 103284 RK	CITY	City	SFR-Basic
99 103286 RK	CITY	City	SFR-Basic
99 103651 MH	RC	Rural Conservation	Double Wide
98 116828 RK	R-5	Rural-5 Acre	Single Family Res-Combo
99 111290 RK	R-5	Rural-5 Acre	Single Family Res-Combo
98 150769 RK	R-5	Rural-5 Acre	Single Family Res-Combo
98 150766 RK	R-5	Rural-5 Acre	Single Family Res-Combo
99 100430 RK	CITY	City	SFR-Basic
99 100431 RK	CITY	City	SFR-Basic
99 100432 RK	CITY	City	SFR-Basic
99 100433 RK	CITY	City	SFR-Basic
99 101607 RK	CITY	City	SFR-Basic
99 110472 RK	CITY	City	SFR-Basic

Accessory Dwelling Units

Index # - File Name: 1.0022 - Single Family Dwellings Data\_Snohomish County.pdf

99 110473 RK	CITY	City	SFR-Basic
99 112066 RK	CITY	City	SFR-Basic
99 112068 RK	CITY	City	SFR-Basic
99 112067 RK	CITY	City	SFR-Basic
99 112069 RK	CITY	City	SFR-Basic
99 110844 RK	CITY	City	SFR-Basic
99 110845 RK	CITY	City	SFR-Basic
99 110846 RK	CITY	City	SFR-Basic
99 101610 RK	CITY	City	SFR-Basic
99 101608 RK	CITY	City	SFR-Basic
99 109797 RK	CITY	City	SFR-Basic
99 104958 RK	CITY	City	SFR-Basic
99 104956 RK	CITY	City	SFR-Basic
99 104959 RK	CITY	City	SFR-Basic
99 104955 RK	CITY	City	SFR-Basic
99 104957 RK	CITY	City	SFR-Basic
99 104954 RK	CITY	City	SFR-Basic
99 101611 RK	CITY	City	SFR-Basic
99 101612 RK	CITY	City	SFR-Basic
99 103026 RK	CITY	City	SFR-Basic
99 102370 RK	CITY	City	SFR-Basic
99 102369 RK	CITY	City	SFR-Basic
99 100434 RK	CITY	City	SFR-Basic
99 100435 RK	CITY	City	SFR-Basic
99 100436 RK	CITY	City	SFR-Basic
99 100437 RK	CITY	City	SFR-Basic
98 150945 RK	PRD-7,200	Residential 7,200 sq. ft.	SFR-Basic
98 150944 RK	PRD-7,200	Residential 7,200 sq. ft.	SFR-Basic
99 101046 MH	R-5	Rural-5 Acre	Triple Wide
99 101614 RK	R-5	Rural-5 Acre	Single Family Res-Combo
99 110668 RK	PRD-7,200	Residential 7,200 sq. ft.	SFR-Basic
99 110729 RK	PRD-7,200	Residential 7,200 sq. ft.	SFR-Basic
99 112398 RK	PRD-7,200	Residential 7,200 sq. ft.	SFR-Basic
99 103942 RK	PRD-7,200	Residential 7,200 sq. ft.	Single Family Res-Combo
99 103954 RK	PRD-7,200	Residential 7,200 sq. ft.	SFR-Basic
99 112396 RK	PRD-7,200	Residential 7,200 sq. ft.	SFR-Basic
99 112648 RK	PRD-7,200	Residential 7,200 sq. ft.	SFR-Basic
99 112649 RK	PRD-7,200	Residential 7,200 sq. ft.	SFR-Basic
98 150855 RK	PRD SA-1	Suburban Agriculture-1 Acre	Single Family Res-Combo
98 150875 RK	PRD SA-1	Suburban Agriculture-1 Acre	Single Family Res-Combo
99 104344 RK	PRD SA-1	Suburban Agriculture-1 Acre	Single Family Res-Combo
98 150874 RK	PRD SA-1	Suburban Agriculture-1 Acre	Single Family Res-Combo
98 150872 RK	PRD SA-1	Suburban Agriculture-1 Acre	Single Family Res-Combo
99 103076 RK	R-7,200	Residential 7,200 sq. ft.	SFR-Basic
98 151141 RK	R-7,200	Residential 7,200 sq. ft.	Single Family Res-Combo
99 101431 RK			Duplex-Basic
98 150788 RK	PRD SA-1	Suburban Agriculture-1 Acre	Single Family Res-Combo

Accessory Dwelling Units

Index # - File Name: 1.0022 - Single Family Dwellings Data\_Snohomish County.pdf

98 150791 RK	PRD SA-1	Suburban Agriculture-1 Acre	Single Family Res-Combo
98 150793 RK	PRD SA-1	Suburban Agriculture-1 Acre	Single Family Res-Combo
98 150796 RK	PRD SA-1	Suburban Agriculture-1 Acre	SFR-Basic
99 109640 RK	PRD-7,200	Residential 7,200 sq. ft.	SFR-Basic
99 109641 RK	PRD-7,200	Residential 7,200 sq. ft.	SFR-Basic
99 109642 RK	PRD-7,200	Residential 7,200 sq. ft.	SFR-Basic
99 109638 RK	PRD-7,200	Residential 7,200 sq. ft.	SFR-Basic
99 109643 RK	PRD-7,200	Residential 7,200 sq. ft.	SFR-Basic
99 109637 RK	PRD-7,200	Residential 7,200 sq. ft.	SFR-Basic
99 110171 RK	PRD-7,200	Residential 7,200 sq. ft.	SFR-Basic
99 101511 RK	PRD-7,200	Residential 7,200 sq. ft.	SFR-Basic
99 101513 RK	PRD-7,200	Residential 7,200 sq. ft.	SFR-Basic
99 101517 RK	PRD-7,200	Residential 7,200 sq. ft.	Single Family Res-Combo
99 110889 RK	PRD-7,200	Residential 7,200 sq. ft.	SFR-Basic
99 102551 RK	PRD-7,200	Residential 7,200 sq. ft.	SFR-Basic
98 116979 RK	R-7,200	Residential 7,200 sq. ft.	Single Family Res-Combo
99 101170 RK	R-7,200	Residential 7,200 sq. ft.	SFR-Basic
99 101171 RK	R-7,200	Residential 7,200 sq. ft.	SFR-Basic
99 101172 RK	R-7,200	Residential 7,200 sq. ft.	SFR-Basic
99 101710 RK	R-5	Rural-5 Acre	Single Family Res-Combo
99 110168 RK	R-5	Rural-5 Acre	Single Family Res-Combo
99 101680 RK	PRD SA-1 : R-5	Rural-5 Acre : Suburban Agri	SFR-Basic
99 101626 RK	R-5	Rural-5 Acre	Single Family Res-Combo
99 109386 RK	R-5	Rural-5 Acre	Single Family Res-Combo
99 104596 RK	R-5	Rural-5 Acre	Single Family Res-Combo
99 102884 RK	R-5	Rural-5 Acre	Single Family Res-Combo
99 105268 RK	R-5	Rural-5 Acre	Single Family Res-Combo
98 110726 RK	R-5	Rural-5 Acre	Single Family Res-Combo
98 101678 RK	R-5	Rural-5 Acre	Single Family Res-Combo
98 107828 RK	R-5	Rural-5 Acre	Single Family Res-Combo
98 101683 RK	R-5	Rural-5 Acre	Single Family Res-Combo
99 102012 RK	CITY	City	Single Family Res-Combo
99 112613 RK	R-9,600	Residential 9,600 sq. ft.	Duplex-Combo
99 101648 RK	R-8,400	Residential 8,400 sq. ft.	SFR-Basic
99 101649 RK	R-8,400	Residential 8,400 sq. ft.	SFR-Basic
99 101714 RK	R-5	Rural-5 Acre	SFR-Basic
99 105349 RK	R-5	Rural-5 Acre	Single Family Res-Combo
99 109897 RK	R-5	Rural-5 Acre	Single Family Res-Combo
99 101713 RK	R-5	Rural-5 Acre	SFR-Basic
99 102094 RK	R-5	Rural-5 Acre	Single Family Res-Combo
99 101736 RK	R-5	Rural-5 Acre	SFR-Basic
99 101738 RK	R-5	Rural-5 Acre	SFR-Basic
99 102320 RK	CITY	City	Single Family Res-Combo
99 101776 MH	R-5	Rural-5 Acre	Double Wide
99 102413 RK	UC	Urban Center	Single Family Res-Combo
99 101651 RK	UC	Urban Center	SFR-Basic
99 101654 RK	UC	Urban Center	SFR-Basic

Accessory Dwelling Units

Index # - File Name: 1.0022 - Single Family Dwellings Data\_Snohomish County.pdf

99 102406 RK	UC	Urban Center	SFR-Basic
99 100844 RK	UC	Urban Center	Single Family Res-Combo
99 102408 RK	UC	Urban Center	SFR-Basic
99 105416 RK	UC	Urban Center	SFR-Basic
99 105417 RK	UC	Urban Center	SFR-Basic
99 102410 RK	UC	Urban Center	SFR-Basic
99 100843 RK	UC	Urban Center	Single Family Res-Combo
99 102411 RK	UC	Urban Center	SFR-Basic
99 102409 RK	UC	Urban Center	SFR-Basic
99 105418 RK	UC	Urban Center	SFR-Basic
99 103797 RK	R-5	Rural-5 Acre	Single Family Res-Combo
99 103800 RK	R-5	Rural-5 Acre	Single Family Res-Combo
99 101924 RK	R-5	Rural-5 Acre	SFR-Basic
99 101909 MH	R-5	Rural-5 Acre	Single Wide
99 109387 RK	CITY	City	SFR-Basic
99 102105 RK	PRD-7,200	Residential 7,200 sq. ft.	Single Family Res-Combo
99 110578 RK	PRD-9,600	Residential 9,600 sq. ft.	SFR-Basic
99 111149 RK	PRD-9,600	Residential 9,600 sq. ft.	SFR-Basic
99 111689 RK	PRD-9,600	Residential 9,600 sq. ft.	SFR-Basic
99 109407 RK	PRD-9,600	Residential 9,600 sq. ft.	SFR-Basic
99 113025 RK	PRD-9,600	Residential 9,600 sq. ft.	Single Family Res-Combo
99 109951 RK	PRD-9,600	Residential 9,600 sq. ft.	SFR-Basic
99 110579 RK	PRD-9,600	Residential 9,600 sq. ft.	SFR-Basic
99 112458 RK	PRD-9,600	Residential 9,600 sq. ft.	SFR-Basic
99 110605 RK	PRD-9,600	Residential 9,600 sq. ft.	SFR-Basic
99 109683 RK	PRD-9,600	Residential 9,600 sq. ft.	SFR-Basic
99 109382 RK	CITY	City	SFR-Basic
99 104952 RK	CITY	City	SFR-Basic
99 103027 RK	CITY	City	SFR-Basic
99 103029 RK	CITY	City	SFR-Basic
99 103032 RK	CITY	City	SFR-Basic
99 103033 RK	CITY	City	SFR-Basic
99 103034 RK	CITY	City	SFR-Basic
99 104553 RK	CITY	City	SFR-Basic
99 104092 RK	CITY	City	SFR-Basic
99 110476 RK	CITY	City	SFR-Basic
99 110474 RK	CITY	City	SFR-Basic
99 109800 RK	CITY	City	SFR-Basic
99 109802 RK	CITY	City	SFR-Basic
99 113281 RK	CITY	City	SFR-Basic
99 113286 RK	CITY	City	SFR-Basic
99 113283 RK	CITY	City	SFR-Basic
99 113287 RK	CITY	City	SFR-Basic
99 113284 RK	CITY	City	SFR-Basic
99 112070 RK	CITY	City	SFR-Basic
99 112073 RK	CITY	City	SFR-Basic
99 112072 RK	CITY	City	SFR-Basic

Accessory Dwelling Units

Index # - File Name: 1.0022 - Single Family Dwellings Data\_Snohomish County.pdf

99 110567 RK	CITY	City	SFR-Basic
99 113288 RK	CITY	City	SFR-Basic
99 110842 RK	CITY	City	SFR-Basic
99 110840 RK	CITY	City	SFR-Basic
99 110843 RK	CITY	City	SFR-Basic
99 110477 RK	CITY	City	SFR-Basic
99 110475 RK	CITY	City	SFR-Basic
99 109801 RK	CITY	City	SFR-Basic
99 104554 RK	CITY	City	SFR-Basic
99 104556 RK	CITY	City	SFR-Basic
99 104555 RK	CITY	City	SFR-Basic
99 104090 RK	CITY	City	SFR-Basic
99 113500 RK	CITY	City	SFR-Basic
99 113494 RK	CITY	City	SFR-Basic
99 113501 RK	CITY	City	SFR-Basic
99 113495 RK	CITY	City	SFR-Basic
99 113502 RK	CITY	City	SFR-Basic
99 113496 RK	CITY	City	SFR-Basic
99 104091 RK	CITY	City	SFR-Basic
99 104557 RK	CITY	City	SFR-Basic
99 109383 RK	CITY	City	SFR-Basic
99 104950 RK	CITY	City	SFR-Basic
99 113285 RK	CITY	City	SFR-Basic
99 113289 RK	CITY	City	SFR-Basic
99 113497 RK	CITY	City	SFR-Basic
99 113503 RK	CITY	City	SFR-Basic
99 113498 RK	CITY	City	SFR-Basic
99 113504 RK	CITY	City	SFR-Basic
99 113499 RK	CITY	City	SFR-Basic
99 113505 RK	CITY	City	SFR-Basic
99 104953 RK	CITY	City	SFR-Basic
99 104951 RK	CITY	City	SFR-Basic
99 109384 RK	CITY	City	SFR-Basic
99 102103 RK	PRD-7,200	Residential 7,200 sq. ft.	Single Family Res-Combo
99 105271 RK	PRD-7,200	Residential 7,200 sq. ft.	SFR-Basic
99 102102 RK	PRD-7,200	Residential 7,200 sq. ft.	Single Family Res-Combo
99 105277 RK	PRD-7,200	Residential 7,200 sq. ft.	SFR-Basic
99 102104 RK	PRD-7,200	Residential 7,200 sq. ft.	Single Family Res-Combo
99 105274 RK	PRD-7,200	Residential 7,200 sq. ft.	SFR-Basic
99 109489 RK	PRD-7,200	Residential 7,200 sq. ft.	SFR-Basic
99 109490 RK	PRD-7,200	Residential 7,200 sq. ft.	SFR-Basic
99 105276 RK	PRD-7,200	Residential 7,200 sq. ft.	SFR-Basic
99 102108 RK	PRD-7,200	Residential 7,200 sq. ft.	Single Family Res-Combo
99 104965 RK	PRD-7,200	Residential 7,200 sq. ft.	SFR-Basic
99 102804 RK	PRD-7,200	Residential 7,200 sq. ft.	Single Family Res-Combo
99 104971 RK	PRD-7,200	Residential 7,200 sq. ft.	SFR-Basic
99 102802 RK	PRD-7,200	Residential 7,200 sq. ft.	Single Family Res-Combo

Accessory Dwelling Units

Index # - File Name: 1.0022 - Single Family Dwellings Data\_Snohomish County.pdf

99 111856 RK	PRD-9,600	Residential 9,600 sq. ft.	Single Family Res-Combo
99 113145 RK	PRD-9,600	Residential 9,600 sq. ft.	Single Family Res-Combo
99 114471 RK	PRD-9,600	Residential 9,600 sq. ft.	SFR-Basic
99 102124 RK	RD	Rural Diversification	Single Family Res-Combo
99 114763 RK	PRD-9,600	Residential 9,600 sq. ft.	Single Family Res-Combo
99 111960 RK	PRD-9,600	Residential 9,600 sq. ft.	SFR-Basic
99 114890 RK	PRD-9,600	Residential 9,600 sq. ft.	SFR-Basic
99 113195 RK	PRD-9,600	Residential 9,600 sq. ft.	Single Family Res-Combo
99 109505 RK	PRD-9,600	Residential 9,600 sq. ft.	Single Family Res-Combo
98 108104 RK	PRD-9,600	Residential 9,600 sq. ft.	Single Family Res-Combo
98 108110 RK	PRD-9,600	Residential 9,600 sq. ft.	Single Family Res-Combo
99 110606 RK	PRD-9,600	Residential 9,600 sq. ft.	SFR-Basic
99 102755 RK	PRD-9,600	Residential 9,600 sq. ft.	SFR-Basic
99 112257 RK	PRD-9,600	Residential 9,600 sq. ft.	Single Family Res-Combo
99 112256 RK	PRD-9,600	Residential 9,600 sq. ft.	Single Family Res-Combo
99 113407 RK	PRD-9,600	Residential 9,600 sq. ft.	SFR-Basic
98 108109 RK	PRD-9,600	Residential 9,600 sq. ft.	Single Family Res-Combo
98 109122 RK	PRD-9,600	Residential 9,600 sq. ft.	Single Family Res-Combo
99 111691 RK	PRD-9,600	Residential 9,600 sq. ft.	SFR-Basic
99 113409 RK	PRD-9,600	Residential 9,600 sq. ft.	SFR-Basic
99 113410 RK	PRD-9,600	Residential 9,600 sq. ft.	SFR-Basic
99 113411 RK	PRD-9,600	Residential 9,600 sq. ft.	SFR-Basic
99 111692 RK	PRD-9,600	Residential 9,600 sq. ft.	SFR-Basic
99 112827 RK	PRD-9,600	Residential 9,600 sq. ft.	SFR-Basic
99 109678 RK	PRD-9,600	Residential 9,600 sq. ft.	SFR-Basic
99 113521 RK	PRD-9,600	Residential 9,600 sq. ft.	SFR-Basic
99 109508 RK	PRD-9,600	Residential 9,600 sq. ft.	SFR-Basic
99 103257 RK	PRD-9,600	Residential 9,600 sq. ft.	SFR-Basic
99 113836 RK	PRD-9,600	Residential 9,600 sq. ft.	SFR-Basic
99 112830 RK	PRD-9,600	Residential 9,600 sq. ft.	SFR-Basic
99 113835 RK	PRD-9,600	Residential 9,600 sq. ft.	SFR-Basic
99 109402 RK	PRD-9,600	Residential 9,600 sq. ft.	SFR-Basic
98 108107 RK	PRD-9,600	Residential 9,600 sq. ft.	Single Family Res-Combo
99 104887 RK	PRD-9,600	Residential 9,600 sq. ft.	SFR-Basic
99 105052 RK	PRD-9,600	Residential 9,600 sq. ft.	SFR-Basic
99 104233 RK	PRD-9,600	Residential 9,600 sq. ft.	SFR-Basic
99 104305 RK	PRD-9,600	Residential 9,600 sq. ft.	SFR-Basic
99 102757 RK	PRD-9,600	Residential 9,600 sq. ft.	SFR-Basic
99 109809 RK	PRD-9,600	Residential 9,600 sq. ft.	SFR-Basic
99 111541 RK	PRD-9,600	Residential 9,600 sq. ft.	SFR-Basic
99 109811 RK	PRD-9,600	Residential 9,600 sq. ft.	SFR-Basic
99 109808 RK	PRD-9,600	Residential 9,600 sq. ft.	SFR-Basic
99 114768 RK	PRD-9,600	Residential 9,600 sq. ft.	Single Family Res-Combo
99 112801 RK	PRD-9,600	Residential 9,600 sq. ft.	SFR-Basic
99 111865 RK	PRD-9,600	Residential 9,600 sq. ft.	Single Family Res-Combo
99 111860 RK	PRD-9,600	Residential 9,600 sq. ft.	Single Family Res-Combo
99 111857 RK	PRD-9,600	Residential 9,600 sq. ft.	Single Family Res-Combo

Accessory Dwelling Units

Index # - File Name: 1.0022 - Single Family Dwellings Data\_Snohomish County.pdf

99 111853 RK	PRD-9,600	Residential 9,600 sq. ft.	Single Family Res-Combo
99 111863 RK	PRD-9,600	Residential 9,600 sq. ft.	Single Family Res-Combo
99 112657 RK	PRD-9,600	Residential 9,600 sq. ft.	Single Family Res-Combo
99 112658 RK	PRD-9,600	Residential 9,600 sq. ft.	Single Family Res-Combo
99 112659 RK	PRD-9,600	Residential 9,600 sq. ft.	Single Family Res-Combo
99 112662 RK	PRD-9,600	Residential 9,600 sq. ft.	Single Family Res-Combo
99 112663 RK	PRD-9,600	Residential 9,600 sq. ft.	Single Family Res-Combo
99 112664 RK	PRD-9,600	Residential 9,600 sq. ft.	Single Family Res-Combo
99 115247 RK	PRD-9,600	Residential 9,600 sq. ft.	SFR-Basic
99 115251 RK	PRD-9,600	Residential 9,600 sq. ft.	Single Family Res-Combo
99 113468 RK	PRD-9,600	Residential 9,600 sq. ft.	Single Family Res-Combo
99 113026 RK	PRD-9,600	Residential 9,600 sq. ft.	Single Family Res-Combo
99 113029 RK	PRD-9,600	Residential 9,600 sq. ft.	SFR-Basic
99 103835 RK	PRD-9,600	Residential 9,600 sq. ft.	Single Family Res-Combo
99 103263 RK	PRD-9,600	Residential 9,600 sq. ft.	Single Family Res-Combo
99 103262 RK	PRD-9,600	Residential 9,600 sq. ft.	Single Family Res-Combo
99 103265 RK	PRD-9,600	Residential 9,600 sq. ft.	Single Family Res-Combo
99 103266 RK	PRD-9,600	Residential 9,600 sq. ft.	Single Family Res-Combo
99 112829 RK	PRD-9,600	Residential 9,600 sq. ft.	SFR-Basic
99 109709 RK	PRD-9,600	Residential 9,600 sq. ft.	Single Family Res-Combo
99 114690 RK	PRD-9,600	Residential 9,600 sq. ft.	SFR-Basic
99 116059 RK	PRD-9,600	Residential 9,600 sq. ft.	SFR-Basic
99 114869 RK	PRD-9,600	Residential 9,600 sq. ft.	SFR-Basic
99 114687 RK	PRD-9,600	Residential 9,600 sq. ft.	SFR-Basic
99 115254 RK	PRD-9,600	Residential 9,600 sq. ft.	Single Family Res-Combo
99 115030 RK	PRD-9,600	Residential 9,600 sq. ft.	SFR-Basic
99 112231 RK	PRD-9,600	Residential 9,600 sq. ft.	SFR-Basic
99 112229 RK	PRD-9,600	Residential 9,600 sq. ft.	SFR-Basic
99 105293 RK	PRD-9,600	Residential 9,600 sq. ft.	Single Family Res-Combo
99 112188 RK	PRD-9,600	Residential 9,600 sq. ft.	SFR-Basic
99 112191 RK	PRD-9,600	Residential 9,600 sq. ft.	SFR-Basic
99 105467 RK	PRD-9,600	Residential 9,600 sq. ft.	Single Family Res-Combo
99 112233 RK	PRD-9,600	Residential 9,600 sq. ft.	SFR-Basic
99 105468 RK	PRD-9,600	Residential 9,600 sq. ft.	Single Family Res-Combo
99 114484 RK	PRD-9,600	Residential 9,600 sq. ft.	SFR-Basic
99 114483 RK	PRD-9,600	Residential 9,600 sq. ft.	SFR-Basic
99 114689 RK	PRD-9,600	Residential 9,600 sq. ft.	SFR-Basic
99 114870 RK	PRD-9,600	Residential 9,600 sq. ft.	Single Family Res-Combo
99 115028 RK	PRD-9,600	Residential 9,600 sq. ft.	SFR-Basic
99 114765 RK	PRD-9,600	Residential 9,600 sq. ft.	Single Family Res-Combo
99 104337 RK	R-5	Rural-5 Acre	Single Family Res-Combo
99 102844 RK	R-5	Rural-5 Acre	Single Family Res-Combo
99 111091 RK	R-5	Rural-5 Acre	Single Family Res-Combo
99 110123 RK	R-5	Rural-5 Acre	Single Family Res-Combo
99 101434 RK	R-5	Rural-5 Acre	Single Family Res-Combo
99 101371 RK	R-5	Rural-5 Acre	Single Family Res-Combo
99 110167 RK	R-5	Rural-5 Acre	Single Family Res-Combo



Accessory Dwelling Units

Index # - File Name: 1.0022 - Single Family Dwellings Data\_Snohomish County.pdf

99 113857 MH	PRD-8,400	Residential 8,400 sq. ft.	Triple Wide
99 101311 RK	R-12,500	Residential 12,500 sq. ft.	Single Family Res-Combo
99 105004 RK	R-5	Rural-5 Acre	Single Family Res-Combo
99 109617 RK	R-5	Rural-5 Acre	Single Family Res-Combo
99 103699 RK	R-5	Rural-5 Acre	Single Family Res-Combo
99 104102 MH	R-5	Rural-5 Acre	Triple Wide
99 105040 MH	R-5	Rural-5 Acre	Double Wide
99 101948 RK	PRD-9,600	Residential 9,600 sq. ft.	SFR-Basic
99 101952 RK	PRD-9,600	Residential 9,600 sq. ft.	SFR-Basic
99 101949 RK	PRD-9,600	Residential 9,600 sq. ft.	SFR-Basic
99 102348 RK	PRD-9,600	Residential 9,600 sq. ft.	SFR-Basic
99 102349 RK	PRD-9,600	Residential 9,600 sq. ft.	SFR-Basic
99 102345 RK	PRD-9,600	Residential 9,600 sq. ft.	SFR-Basic
99 102353 RK	PRD-9,600	Residential 9,600 sq. ft.	SFR-Basic
99 100982 RK	PRD-9,600	Residential 9,600 sq. ft.	SFR-Basic
99 100984 RK	PRD-9,600	Residential 9,600 sq. ft.	SFR-Basic
99 100539 RK	PRD-9,600	Residential 9,600 sq. ft.	SFR-Basic
99 100541 RK	PRD-9,600	Residential 9,600 sq. ft.	SFR-Basic
99 100542 RK	PRD-9,600	Residential 9,600 sq. ft.	SFR-Basic
99 100543 RK	PRD-9,600	Residential 9,600 sq. ft.	SFR-Basic
99 100544 RK	PRD-9,600	Residential 9,600 sq. ft.	SFR-Basic
99 100545 RK	PRD-9,600	Residential 9,600 sq. ft.	SFR-Basic
99 100547 RK	PRD-9,600	Residential 9,600 sq. ft.	SFR-Basic
99 111564 RK	PRD-9,600	Residential 9,600 sq. ft.	SFR-Basic
99 111555 RK	PRD-9,600	Residential 9,600 sq. ft.	SFR-Basic
99 111445 RK	PRD-9,600	Residential 9,600 sq. ft.	SFR-Basic
99 100974 RK	PRD-9,600	Residential 9,600 sq. ft.	SFR-Basic
99 111788 RK	PRD-9,600	Residential 9,600 sq. ft.	SFR-Basic
99 111789 RK	PRD-9,600	Residential 9,600 sq. ft.	SFR-Basic
99 111790 RK	PRD-9,600	Residential 9,600 sq. ft.	SFR-Basic
99 111786 RK	PRD-9,600	Residential 9,600 sq. ft.	SFR-Basic
99 111791 RK	PRD-9,600	Residential 9,600 sq. ft.	SFR-Basic
99 111792 RK	PRD-9,600	Residential 9,600 sq. ft.	SFR-Basic
99 111793 RK	PRD-9,600	Residential 9,600 sq. ft.	SFR-Basic
99 111787 RK	PRD-9,600	Residential 9,600 sq. ft.	SFR-Basic
99 111794 RK	PRD-9,600	Residential 9,600 sq. ft.	SFR-Basic
98 108768 RK	PRD-9,600	Residential 9,600 sq. ft.	Single Family Res-Combo
98 108769 RK	PRD-9,600	Residential 9,600 sq. ft.	Single Family Res-Combo
99 111795 RK	PRD-9,600	Residential 9,600 sq. ft.	SFR-Basic
99 111565 RK	PRD-9,600	Residential 9,600 sq. ft.	SFR-Basic
98 108759 RK	PRD-9,600	Residential 9,600 sq. ft.	Single Family Res-Combo
98 108766 RK	PRD-9,600	Residential 9,600 sq. ft.	Single Family Res-Combo
99 115700 MH	R-5	Rural-5 Acre	Double Wide
99 100447 RK	CITY	City	Single Family Res-Combo
99 104363 RK	R-5	Rural-5 Acre	Single Family Res-Combo
99 100988 RK	R-5	Rural-5 Acre	Single Family Res-Combo
99 103522 RK	R-5	Rural-5 Acre	Single Family Res-Combo

Accessory Dwelling Units

Index # - File Name: 1.0022 - Single Family Dwellings Data\_Snohomish County.pdf

99 110188 RK	R-5	Rural-5 Acre	Single Family Res-Combo
99 110191 RK	R-5	Rural-5 Acre	Single Family Res-Combo
99 110193 RK	R-5	Rural-5 Acre	Single Family Res-Combo
99 100793 RK	R-5	Rural-5 Acre	Single Family Res-Combo
99 100795 RK	R-5	Rural-5 Acre	Single Family Res-Combo
99 103526 RK	R-5	Rural-5 Acre	Single Family Res-Combo
99 103525 RK	R-5	Rural-5 Acre	Single Family Res-Combo
99 100776 RK	R-5	Rural-5 Acre	Single Family Res-Combo
99 100803 MH	R-5	Rural-5 Acre	Double Wide
99 100812 RK	CITY	City	SFR-Basic
99 101190 RK	PRD-9,600	Residential 9,600 sq. ft.	SFR-Basic
99 101191 RK	PRD-9,600	Residential 9,600 sq. ft.	SFR-Basic
99 101192 RK	PRD-9,600	Residential 9,600 sq. ft.	SFR-Basic
99 101193 RK	PRD-9,600	Residential 9,600 sq. ft.	SFR-Basic
99 101194 RK	PRD-9,600	Residential 9,600 sq. ft.	SFR-Basic
99 101195 RK	PRD-9,600	Residential 9,600 sq. ft.	SFR-Basic
99 101196 RK	PRD-9,600	Residential 9,600 sq. ft.	SFR-Basic
99 101197 RK	PRD-9,600	Residential 9,600 sq. ft.	SFR-Basic
99 101198 RK	PRD-9,600	Residential 9,600 sq. ft.	SFR-Basic
99 101199 RK	PRD-9,600	Residential 9,600 sq. ft.	SFR-Basic
99 101200 RK	PRD-9,600	Residential 9,600 sq. ft.	SFR-Basic
99 101201 RK	PRD-9,600	Residential 9,600 sq. ft.	SFR-Basic
99 101203 RK	PRD-9,600	Residential 9,600 sq. ft.	SFR-Basic
99 103325 RK	PRD-9,600	Residential 9,600 sq. ft.	SFR-Basic
99 103326 RK	PRD-9,600	Residential 9,600 sq. ft.	SFR-Basic
99 103327 RK	PRD-9,600	Residential 9,600 sq. ft.	SFR-Basic
99 103554 RK	PRD-9,600	Residential 9,600 sq. ft.	SFR-Basic
99 103555 RK	PRD-9,600	Residential 9,600 sq. ft.	SFR-Basic
99 103557 RK	PRD-9,600	Residential 9,600 sq. ft.	SFR-Basic
99 104281 RK	PRD-9,600	Residential 9,600 sq. ft.	SFR-Basic
99 104284 RK	PRD-9,600	Residential 9,600 sq. ft.	SFR-Basic
99 104283 RK	PRD-9,600	Residential 9,600 sq. ft.	SFR-Basic
99 104279 RK	PRD-9,600	Residential 9,600 sq. ft.	SFR-Basic
99 104276 RK	PRD-9,600	Residential 9,600 sq. ft.	SFR-Basic
99 104278 RK	PRD-9,600	Residential 9,600 sq. ft.	SFR-Basic
99 104277 RK	PRD-9,600	Residential 9,600 sq. ft.	SFR-Basic
99 104282 RK	PRD-9,600	Residential 9,600 sq. ft.	SFR-Basic
99 104999 RK	PRD-9,600	Residential 9,600 sq. ft.	SFR-Basic
99 104986 RK	PRD-9,600	Residential 9,600 sq. ft.	SFR-Basic
99 104994 RK	PRD-9,600	Residential 9,600 sq. ft.	SFR-Basic
99 104998 RK	PRD-9,600	Residential 9,600 sq. ft.	SFR-Basic
99 104987 RK	PRD-9,600	Residential 9,600 sq. ft.	SFR-Basic
99 105000 RK	PRD-9,600	Residential 9,600 sq. ft.	SFR-Basic
99 104991 RK	PRD-9,600	Residential 9,600 sq. ft.	SFR-Basic
99 104989 RK	PRD-9,600	Residential 9,600 sq. ft.	SFR-Basic
99 104995 RK	PRD-9,600	Residential 9,600 sq. ft.	SFR-Basic
99 104988 RK	PRD-9,600	Residential 9,600 sq. ft.	SFR-Basic

Accessory Dwelling Units

Index # - File Name: 1.0022 - Single Family Dwellings Data\_Snohomish County.pdf

99 104992 RK	PRD-9,600	Residential 9,600 sq. ft.	SFR-Basic
99 109985 RK	PRD-9,600	Residential 9,600 sq. ft.	SFR-Basic
99 109986 RK	PRD-9,600	Residential 9,600 sq. ft.	SFR-Basic
99 109989 RK	PRD-9,600	Residential 9,600 sq. ft.	SFR-Basic
99 109990 RK	PRD-9,600	Residential 9,600 sq. ft.	SFR-Basic
99 109991 RK	PRD-9,600	Residential 9,600 sq. ft.	SFR-Basic
99 109992 RK	PRD-9,600	Residential 9,600 sq. ft.	SFR-Basic
99 109994 RK	PRD-9,600	Residential 9,600 sq. ft.	SFR-Basic
99 109996 RK	PRD-9,600	Residential 9,600 sq. ft.	SFR-Basic
99 109997 RK	PRD-9,600	Residential 9,600 sq. ft.	SFR-Basic
99 109998 RK	PRD-9,600	Residential 9,600 sq. ft.	SFR-Basic
99 110000 RK	PRD-9,600	Residential 9,600 sq. ft.	SFR-Basic
99 110001 RK	PRD-9,600	Residential 9,600 sq. ft.	SFR-Basic
99 110002 RK	PRD-9,600	Residential 9,600 sq. ft.	SFR-Basic
99 110004 RK	PRD-9,600	Residential 9,600 sq. ft.	SFR-Basic
99 110005 RK	PRD-9,600	Residential 9,600 sq. ft.	SFR-Basic
99 100911 RK	R-5	Rural-5 Acre	Single Family Res-Combo
99 101035 RK	CITY	City	Single Family Res-Combo
98 105677 RK	CITY	City	Single Family Res-Combo
98 105683 RK	CITY	City	SFR-Basic
99 102135 RK	CITY	City	SFR-Basic
99 101034 RK	CITY	City	Single Family Res-Combo
99 100598 RK	CITY	City	Single Family Res-Combo
99 100192 RK	CITY	City	SFR-Basic
99 102132 RK	CITY	City	SFR-Basic
99 101694 RK	CITY	City	SFR-Basic
99 101696 RK	CITY	City	SFR-Basic
99 100186 RK	CITY	City	SFR-Basic
99 100280 RK	F	Forestry	Single Family Res-Combo
99 110459 RK	R-7,200	Residential 7,200 sq. ft.	SFR-Basic
99 100472 RK	R-7,200	Residential 7,200 sq. ft.	Single Family Res-Combo
99 100473 RK	R-7,200	Residential 7,200 sq. ft.	Single Family Res-Combo
98 110719 RK	R-7,200	Residential 7,200 sq. ft.	Single Family Res-Combo
98 151162 RK	R-7,200	Residential 7,200 sq. ft.	Single Family Res-Combo
99 110785 RK	R-7,200	Residential 7,200 sq. ft.	Single Family Res-Combo
98 108648 RK	R-7,200	Residential 7,200 sq. ft.	Single Family Res-Combo
99 102119 RK	R-7,200	Residential 7,200 sq. ft.	Single Family Res-Combo
99 104036 RK	R-7,200	Residential 7,200 sq. ft.	Single Family Res-Combo
99 100200 RK	R-7,200	Residential 7,200 sq. ft.	SFR-Basic
99 100202 RK	R-7,200	Residential 7,200 sq. ft.	SFR-Basic
99 100203 RK	R-7,200	Residential 7,200 sq. ft.	SFR-Basic
99 100471 RK	R-7,200	Residential 7,200 sq. ft.	Single Family Res-Combo
99 100204 RK	R-7,200	Residential 7,200 sq. ft.	SFR-Basic
99 100908 RK	R-7,200	Residential 7,200 sq. ft.	SFR-Basic
99 103279 RK	R-7,200	Residential 7,200 sq. ft.	SFR-Basic
99 100205 RK	R-7,200	Residential 7,200 sq. ft.	SFR-Basic
99 110460 RK	R-7,200	Residential 7,200 sq. ft.	SFR-Basic

Accessory Dwelling Units

Index # - File Name: 1.0022 - Single Family Dwellings Data\_Snohomish County.pdf

99 100917 RK	R-7,200	Residential 7,200 sq. ft.	SFR-Basic
99 100206 RK	R-7,200	Residential 7,200 sq. ft.	SFR-Basic
99 111180 RK	R-7,200	Residential 7,200 sq. ft.	SFR-Basic
99 100208 RK	R-7,200	Residential 7,200 sq. ft.	SFR-Basic
99 112467 RK	R-7,200	Residential 7,200 sq. ft.	Single Family Res-Combo
99 100323 RK	R-5	Rural-5 Acre	Single Family Res-Combo
99 104925 MH	RRT-10	Rural Resource Transition-1( Double Wide	
99 100357 MH	RRT-10	Rural Resource Transition-1( Double Wide	
99 100526 RK	R-5	Rural-5 Acre	Single Family Res-Combo
99 111697 RK	PRD-9,600	Residential 9,600 sq. ft.	SFR-Basic
99 111694 RK	PRD-9,600	Residential 9,600 sq. ft.	SFR-Basic
99 111700 RK	PRD-9,600	Residential 9,600 sq. ft.	SFR-Basic
99 111698 RK	PRD-9,600	Residential 9,600 sq. ft.	SFR-Basic
99 111031 RK	PRD-9,600	Residential 9,600 sq. ft.	SFR-Basic
99 111032 RK	PRD-9,600	Residential 9,600 sq. ft.	SFR-Basic
99 111027 RK	PRD-9,600	Residential 9,600 sq. ft.	SFR-Basic
99 111033 RK	PRD-9,600	Residential 9,600 sq. ft.	SFR-Basic
99 111034 RK	PRD-9,600	Residential 9,600 sq. ft.	SFR-Basic
99 111028 RK	PRD-9,600	Residential 9,600 sq. ft.	SFR-Basic
99 101936 RK	PRD-9,600	Residential 9,600 sq. ft.	SFR-Basic
99 101937 RK	PRD-9,600	Residential 9,600 sq. ft.	SFR-Basic
99 101953 RK	PRD-9,600	Residential 9,600 sq. ft.	SFR-Basic
99 101963 RK	PRD-9,600	Residential 9,600 sq. ft.	SFR-Basic
99 101964 RK	PRD-9,600	Residential 9,600 sq. ft.	SFR-Basic
99 101939 RK	PRD-9,600	Residential 9,600 sq. ft.	SFR-Basic
99 101965 RK	PRD-9,600	Residential 9,600 sq. ft.	SFR-Basic
99 101954 RK	PRD-9,600	Residential 9,600 sq. ft.	SFR-Basic
99 101966 RK	PRD-9,600	Residential 9,600 sq. ft.	SFR-Basic
99 101967 RK	PRD-9,600	Residential 9,600 sq. ft.	SFR-Basic
99 101968 RK	PRD-9,600	Residential 9,600 sq. ft.	SFR-Basic
99 101955 RK	PRD-9,600	Residential 9,600 sq. ft.	SFR-Basic
99 101969 RK	PRD-9,600	Residential 9,600 sq. ft.	SFR-Basic
99 101970 RK	PRD-9,600	Residential 9,600 sq. ft.	SFR-Basic
99 101971 RK	PRD-9,600	Residential 9,600 sq. ft.	SFR-Basic
99 101956 RK	PRD-9,600	Residential 9,600 sq. ft.	SFR-Basic
99 101972 RK	PRD-9,600	Residential 9,600 sq. ft.	SFR-Basic
99 111440 RK	PRD-9,600	Residential 9,600 sq. ft.	SFR-Basic
99 111442 RK	PRD-9,600	Residential 9,600 sq. ft.	SFR-Basic
99 111550 RK	PRD-9,600	Residential 9,600 sq. ft.	SFR-Basic
99 111560 RK	PRD-9,600	Residential 9,600 sq. ft.	SFR-Basic
99 111561 RK	PRD-9,600	Residential 9,600 sq. ft.	SFR-Basic
99 111559 RK	PRD-9,600	Residential 9,600 sq. ft.	SFR-Basic
99 111552 RK	PRD-9,600	Residential 9,600 sq. ft.	SFR-Basic
99 111443 RK	PRD-9,600	Residential 9,600 sq. ft.	SFR-Basic
99 111553 RK	PRD-9,600	Residential 9,600 sq. ft.	SFR-Basic
99 101950 RK	PRD-9,600	Residential 9,600 sq. ft.	SFR-Basic
99 101943 RK	PRD-9,600	Residential 9,600 sq. ft.	SFR-Basic

Accessory Dwelling Units

Index # - File Name: 1.0022 - Single Family Dwellings Data\_Snohomish County.pdf

99 101951 RK	PRD-9,600	Residential 9,600 sq. ft.	SFR-Basic
99 101946 RK	PRD-9,600	Residential 9,600 sq. ft.	SFR-Basic
99 101947 RK	PRD-9,600	Residential 9,600 sq. ft.	SFR-Basic
99 111695 RK	PRD-9,600	Residential 9,600 sq. ft.	SFR-Basic
99 111702 RK	PRD-9,600	Residential 9,600 sq. ft.	SFR-Basic
99 111703 RK	PRD-9,600	Residential 9,600 sq. ft.	SFR-Basic
99 111035 RK	PRD-9,600	Residential 9,600 sq. ft.	SFR-Basic
99 111699 RK	PRD-9,600	Residential 9,600 sq. ft.	SFR-Basic
99 111029 RK	PRD-9,600	Residential 9,600 sq. ft.	SFR-Basic
99 111030 RK	PRD-9,600	Residential 9,600 sq. ft.	SFR-Basic
99 111696 RK	PRD-9,600	Residential 9,600 sq. ft.	SFR-Basic
99 111036 RK	PRD-9,600	Residential 9,600 sq. ft.	SFR-Basic
99 101957 RK	PRD-9,600	Residential 9,600 sq. ft.	SFR-Basic
99 101940 RK	PRD-9,600	Residential 9,600 sq. ft.	SFR-Basic
99 101958 RK	PRD-9,600	Residential 9,600 sq. ft.	SFR-Basic
99 101973 RK	PRD-9,600	Residential 9,600 sq. ft.	SFR-Basic
99 101959 RK	PRD-9,600	Residential 9,600 sq. ft.	SFR-Basic
99 100975 RK	PRD-9,600	Residential 9,600 sq. ft.	SFR-Basic
99 100977 RK	PRD-9,600	Residential 9,600 sq. ft.	SFR-Basic
99 100976 RK	PRD-9,600	Residential 9,600 sq. ft.	SFR-Basic
99 100978 RK	PRD-9,600	Residential 9,600 sq. ft.	SFR-Basic
98 108767 RK	PRD-9,600	Residential 9,600 sq. ft.	Single Family Res-Combo
99 100530 RK	PRD-9,600	Residential 9,600 sq. ft.	SFR-Basic
99 100979 RK	PRD-9,600	Residential 9,600 sq. ft.	SFR-Basic
99 100980 RK	PRD-9,600	Residential 9,600 sq. ft.	SFR-Basic
99 101960 RK	PRD-9,600	Residential 9,600 sq. ft.	SFR-Basic
99 101941 RK	PRD-9,600	Residential 9,600 sq. ft.	SFR-Basic
99 101974 RK	PRD-9,600	Residential 9,600 sq. ft.	SFR-Basic
99 101961 RK	PRD-9,600	Residential 9,600 sq. ft.	SFR-Basic
99 101975 RK	PRD-9,600	Residential 9,600 sq. ft.	SFR-Basic
99 101962 RK	PRD-9,600	Residential 9,600 sq. ft.	SFR-Basic
99 100981 RK	PRD-9,600	Residential 9,600 sq. ft.	SFR-Basic
99 101234 RK	PRD-9,600	Residential 9,600 sq. ft.	SFR-Basic
99 101235 RK	PRD-9,600	Residential 9,600 sq. ft.	SFR-Basic
99 101236 RK	PRD-9,600	Residential 9,600 sq. ft.	SFR-Basic
99 101237 RK	PRD-9,600	Residential 9,600 sq. ft.	SFR-Basic
99 101238 RK	PRD-9,600	Residential 9,600 sq. ft.	SFR-Basic
99 101239 RK	PRD-9,600	Residential 9,600 sq. ft.	SFR-Basic
99 101240 RK	PRD-9,600	Residential 9,600 sq. ft.	SFR-Basic
99 101242 RK	PRD-9,600	Residential 9,600 sq. ft.	SFR-Basic
99 101243 RK	PRD-9,600	Residential 9,600 sq. ft.	SFR-Basic
99 101246 RK	PRD-9,600	Residential 9,600 sq. ft.	SFR-Basic
99 101247 RK	PRD-9,600	Residential 9,600 sq. ft.	SFR-Basic
99 101248 RK	PRD-9,600	Residential 9,600 sq. ft.	SFR-Basic
99 101976 RK	PRD-9,600	Residential 9,600 sq. ft.	SFR-Basic
99 101977 RK	PRD-9,600	Residential 9,600 sq. ft.	SFR-Basic
99 111562 RK	PRD-9,600	Residential 9,600 sq. ft.	SFR-Basic

Accessory Dwelling Units

Index # - File Name: 1.0022 - Single Family Dwellings Data\_Snohomish County.pdf

99 111556 RK	PRD-9,600	Residential 9,600 sq. ft.	SFR-Basic
99 111446 RK	PRD-9,600	Residential 9,600 sq. ft.	SFR-Basic
99 111438 RK	PRD-9,600	Residential 9,600 sq. ft.	SFR-Basic
99 100970 RK	PRD-9,600	Residential 9,600 sq. ft.	SFR-Basic
99 100971 RK	PRD-9,600	Residential 9,600 sq. ft.	SFR-Basic
99 100972 RK	PRD-9,600	Residential 9,600 sq. ft.	SFR-Basic
99 100973 RK	PRD-9,600	Residential 9,600 sq. ft.	SFR-Basic
99 100531 RK	PRD-9,600	Residential 9,600 sq. ft.	SFR-Basic
99 100532 RK	PRD-9,600	Residential 9,600 sq. ft.	SFR-Basic
99 100534 RK	PRD-9,600	Residential 9,600 sq. ft.	SFR-Basic
99 100536 RK	PRD-9,600	Residential 9,600 sq. ft.	SFR-Basic
99 100537 RK	PRD-9,600	Residential 9,600 sq. ft.	SFR-Basic
99 100538 RK	PRD-9,600	Residential 9,600 sq. ft.	SFR-Basic
99 101250 RK	PRD-9,600	Residential 9,600 sq. ft.	SFR-Basic
99 101251 RK	PRD-9,600	Residential 9,600 sq. ft.	SFR-Basic
99 101252 RK	PRD-9,600	Residential 9,600 sq. ft.	SFR-Basic
99 101253 RK	PRD-9,600	Residential 9,600 sq. ft.	SFR-Basic
99 101254 RK	PRD-9,600	Residential 9,600 sq. ft.	SFR-Basic
98 108762 RK	PRD-9,600	Residential 9,600 sq. ft.	Single Family Res-Combo
99 111557 RK	PRD-9,600	Residential 9,600 sq. ft.	SFR-Basic
99 111558 RK	PRD-9,600	Residential 9,600 sq. ft.	SFR-Basic
99 111447 RK	PRD-9,600	Residential 9,600 sq. ft.	SFR-Basic
99 111448 RK	PRD-9,600	Residential 9,600 sq. ft.	SFR-Basic
99 111449 RK	PRD-9,600	Residential 9,600 sq. ft.	SFR-Basic
99 102354 RK	PRD-9,600	Residential 9,600 sq. ft.	SFR-Basic
99 102347 RK	PRD-9,600	Residential 9,600 sq. ft.	SFR-Basic
99 102355 RK	PRD-9,600	Residential 9,600 sq. ft.	SFR-Basic
99 102350 RK	PRD-9,600	Residential 9,600 sq. ft.	SFR-Basic
99 102356 RK	PRD-9,600	Residential 9,600 sq. ft.	SFR-Basic
99 102358 RK	PRD-9,600	Residential 9,600 sq. ft.	SFR-Basic
99 102351 RK	PRD-9,600	Residential 9,600 sq. ft.	SFR-Basic
99 100452 RK	PRD-9,600	Residential 9,600 sq. ft.	SFR-Basic
99 100451 RK	PRD-9,600	Residential 9,600 sq. ft.	SFR-Basic
99 103569 RK	R-7,200	Residential 7,200 sq. ft.	SFR-Basic
99 103567 RK	R-7,200	Residential 7,200 sq. ft.	SFR-Basic
99 104757 RK	R-5	Rural-5 Acre	Single Family Res-Combo
99 104754 RK	R-5	Rural-5 Acre	Single Family Res-Combo
99 103502 RK	RD	Rural Diversification	Single Family Res-Combo
99 114348 RK	R-7,200	Residential 7,200 sq. ft.	SFR-Basic
99 111162 RK	R-5	Rural-5 Acre	Single Family Res-Combo
99 103691 RK	R-5	Rural-5 Acre	Single Family Res-Combo
99 103726 RK	R-5	Rural-5 Acre	SFR-Basic
99 110142 RK	R-5	Rural-5 Acre	SFR-Basic
99 104900 MH	R-5	Rural-5 Acre	Double Wide
99 105376 RK	R-5	Rural-5 Acre	Single Family Res-Combo
99 103323 RK	R-5	Rural-5 Acre	Single Family Res-Combo
99 103838 RK	PRD-9,600	Residential 9,600 sq. ft.	SFR-Basic

Accessory Dwelling Units

Index # - File Name: 1.0022 - Single Family Dwellings Data\_Snohomish County.pdf

99 103837 RK	PRD-9,600	Residential 9,600 sq. ft.	SFR-Basic
99 103880 RK	PRD-9,600	Residential 9,600 sq. ft.	SFR-Basic
99 104578 RK	PRD-9,600	Residential 9,600 sq. ft.	SFR-Basic
99 103884 RK	PRD-9,600	Residential 9,600 sq. ft.	SFR-Basic
99 104585 RK	PRD-9,600	Residential 9,600 sq. ft.	SFR-Basic
99 104579 RK	PRD-9,600	Residential 9,600 sq. ft.	SFR-Basic
99 104586 RK	PRD-9,600	Residential 9,600 sq. ft.	SFR-Basic
99 104580 RK	PRD-9,600	Residential 9,600 sq. ft.	SFR-Basic
99 104581 RK	PRD-9,600	Residential 9,600 sq. ft.	SFR-Basic
99 104587 RK	PRD-9,600	Residential 9,600 sq. ft.	SFR-Basic
99 104592 RK	PRD-9,600	Residential 9,600 sq. ft.	SFR-Basic
99 104593 RK	PRD-9,600	Residential 9,600 sq. ft.	SFR-Basic
99 104589 RK	PRD-9,600	Residential 9,600 sq. ft.	SFR-Basic
99 104590 RK	PRD-9,600	Residential 9,600 sq. ft.	SFR-Basic
99 104582 RK	PRD-9,600	Residential 9,600 sq. ft.	SFR-Basic
99 109504 RK	R-5	Rural-5 Acre	Single Family Res-Combo
99 103149 RK	CITY	City	Single Family Res-Combo
99 104907 RK	CITY	City	Single Family Res-Combo
99 103781 RK	CITY	City	SFR-Basic
99 110788 RK	CITY	City	SFR-Basic
98 108175 RK	CITY	City	Single Family Res-Combo
99 110791 RK	CITY	City	SFR-Basic
99 104098 RK	CITY	City	SFR-Basic
99 103782 RK	CITY	City	SFR-Basic
98 110299 RK	CITY	City	Single Family Res-Combo
98 107187 RK	CITY	City	Single Family Res-Combo
99 104727 RK	CITY	City	SFR-Basic
99 110739 RK	CITY	City	Single Family Res-Combo
99 103783 RK	CITY	City	SFR-Basic
99 104909 RK	CITY	City	Single Family Res-Combo
99 110789 RK	CITY	City	SFR-Basic
99 105377 RK	CITY	City	SFR-Basic
99 105375 RK	CITY	City	SFR-Basic
99 104097 RK	CITY	City	SFR-Basic
99 103784 RK	CITY	City	SFR-Basic
99 111510 RK	CITY	City	SFR-Basic
99 103785 RK	CITY	City	SFR-Basic
99 111512 RK	CITY	City	Single Family Res-Combo
99 103780 RK	CITY	City	SFR-Basic
99 111511 RK	CITY	City	SFR-Basic
99 104728 RK	CITY	City	SFR-Basic
99 104729 RK	CITY	City	SFR-Basic
99 111946 RK	CITY	City	SFR-Basic
99 111947 RK	CITY	City	Single Family Res-Combo
99 104902 RK	CITY	City	Single Family Res-Combo
99 113747 RK	R-5	Rural-5 Acre	SFR-Basic
99 103805 RK	R-8,400	Residential 8,400 sq. ft.	Single Family Res-Combo

Accessory Dwelling Units

Index # - File Name: 1.0022 - Single Family Dwellings Data\_Snohomish County.pdf

99 110781 RK	R-7,200	Residential 7,200 sq. ft.	Single Family Res-Combo
99 104084 RK	R-7,200	Residential 7,200 sq. ft.	Single Family Res-Combo
99 104082 RK	R-7,200	Residential 7,200 sq. ft.	Single Family Res-Combo
99 104083 RK	R-7,200	Residential 7,200 sq. ft.	Single Family Res-Combo
99 109978 RK	R-7,200	Residential 7,200 sq. ft.	SFR-Basic
99 104464 RK	R-7,200	Residential 7,200 sq. ft.	Single Family Res-Combo
99 109975 RK	R-7,200	Residential 7,200 sq. ft.	Single Family Res-Combo
99 103959 RK	R-5	Rural-5 Acre	Single Family Res-Combo
99 105386 MH	R-5	Rural-5 Acre	Double Wide
99 104889 RK	LDMR	Low Density Multiple Reside	Single Family Res-Combo
99 104888 RK	LDMR	Low Density Multiple Reside	Single Family Res-Combo
99 109598 RK	LDMR	Low Density Multiple Reside	Single Family Res-Combo
99 109311 RK	LDMR	Low Density Multiple Reside	Single Family Res-Combo
98 108646 RK	PRD-9,600	Residential 9,600 sq. ft.	Single Family Res-Combo
98 109746 RK	PRD-9,600	Residential 9,600 sq. ft.	Single Family Res-Combo
99 104208 RK	PRD-9,600	Residential 9,600 sq. ft.	SFR-Basic
99 104209 RK	PRD-9,600	Residential 9,600 sq. ft.	SFR-Basic
99 104210 RK	PRD-9,600	Residential 9,600 sq. ft.	SFR-Basic
99 115324 RK	PRD-9,600	Residential 9,600 sq. ft.	SFR-Basic
99 104211 RK	PRD-9,600	Residential 9,600 sq. ft.	SFR-Basic
99 104212 RK	PRD-9,600	Residential 9,600 sq. ft.	SFR-Basic
99 104061 RK	PRD-9,600	Residential 9,600 sq. ft.	SFR-Basic
99 104057 RK	PRD-9,600	Residential 9,600 sq. ft.	SFR-Basic
99 103474 RK	R-8,400	Residential 8,400 sq. ft.	Single Family Res-Combo
99 103473 RK	F	Forestry	Single Family Res-Combo
99 109334 MH	R-5	Rural-5 Acre	Triple Wide
99 103485 RK	R-7,200	Residential 7,200 sq. ft.	Single Family Res-Combo
99 110028 RK	R-5	Rural-5 Acre	SFR-Basic
99 103577 RK	R-9,600	Residential 9,600 sq. ft.	Single Family Res-Combo
98 150983 RK	R-7,200	Residential 7,200 sq. ft.	Single Family Res-Combo
98 109704 RK	R-7,200	Residential 7,200 sq. ft.	Single Family Res-Combo
98 109703 RK	R-7,200	Residential 7,200 sq. ft.	Single Family Res-Combo
99 114633 RK	F	Forestry	Single Family Res-Combo
99 104064 MH	R-5	Rural-5 Acre	Double Wide
99 113802 RK	R-5	Rural-5 Acre	SFR-Basic
99 110807 RK	R-5	Rural-5 Acre	SFR-Basic
99 114272 RK	R-5	Rural-5 Acre	SFR-Basic
99 114273 RK	R-5	Rural-5 Acre	SFR-Basic
99 115018 RK	R-5	Rural-5 Acre	SFR-Basic
99 115016 RK	R-5	Rural-5 Acre	SFR-Basic
99 110651 RK	R-5	Rural-5 Acre	SFR-Basic
99 110652 RK	R-5	Rural-5 Acre	SFR-Basic
99 110654 RK	R-5	Rural-5 Acre	SFR-Basic
99 110653 RK	R-5	Rural-5 Acre	SFR-Basic
98 150999 RK	R-5	Rural-5 Acre	Single Family Res-Combo
98 151131 RK	R-5	Rural-5 Acre	Single Family Res-Combo
98 150998 RK	R-5	Rural-5 Acre	Single Family Res-Combo



Accessory Dwelling Units

Index # - File Name: 1.0022 - Single Family Dwellings Data\_Snohomish County.pdf

99 100393 RK	R-5	Rural-5 Acre	Single Family Res-Combo
99 110284 RK	R-5	Rural-5 Acre	SFR-Basic
99 110287 RK	R-5	Rural-5 Acre	SFR-Basic
99 110285 RK	R-5	Rural-5 Acre	SFR-Basic
99 111053 RK	R-5	Rural-5 Acre	Single Family Res-Combo
99 110283 RK	R-5	Rural-5 Acre	SFR-Basic
99 111054 RK	R-5	Rural-5 Acre	Single Family Res-Combo
99 110286 RK	R-5	Rural-5 Acre	SFR-Basic
99 115015 RK	R-5	Rural-5 Acre	SFR-Basic
99 111052 RK	R-5	Rural-5 Acre	Single Family Res-Combo
99 105330 RK	R-5	Rural-5 Acre	SFR-Basic
99 112305 MH	R-5	Rural-5 Acre	Double Wide
99 104194 MH	R-5	Rural-5 Acre	Double Wide
99 110139 RK	R-5	Rural-5 Acre	Single Family Res-Combo
99 111836 RK	R-5	Rural-5 Acre	Single Family Res-Combo
99 111392 RK	R-5	Rural-5 Acre	Single Family Res-Combo
99 110640 RK	R-5	Rural-5 Acre	Single Family Res-Combo
99 105255 RK	R-5	Rural-5 Acre	SFR-Basic
99 104419 RK	R-5	Rural-5 Acre	Single Family Res-Combo
99 104431 RK	R-5	Rural-5 Acre	Single Family Res-Combo
99 104451 RK	R-5	Rural-5 Acre	Single Family Res-Combo
99 104473 RK	R-5	Rural-5 Acre	Single Family Res-Combo
99 104369 MH	R-5	Rural-5 Acre	Triple Wide
99 110544 RK	R-5 : RRT-10	Rural Resource Transition-10	Single Family Res-Combo
99 104548 RK	R-5	Rural-5 Acre	Single Family Res-Combo
99 104666 RK	PRD-7,200	Residential 7,200 sq. ft.	SFR-Basic
99 104769 RK	R-5	Rural-5 Acre	Single Family Res-Combo
99 113788 RK	R-5	Rural-5 Acre	Single Family Res-Combo
99 112485 RK	R-5	Rural-5 Acre	Single Family Res-Combo
99 113088 RK	R-5	Rural-5 Acre	Single Family Res-Combo
99 113077 RK	R-5	Rural-5 Acre	Single Family Res-Combo
99 114238 RK	R-5	Rural-5 Acre	Single Family Res-Combo
99 104635 MH	MHP	Mobile Home Park	MH Park-Single Wide
99 101920 RK	CITY	City	Duplex-Combo
99 114447 RK	R-5	Rural-5 Acre	Single Family Res-Combo
99 114141 RK	R-5	Rural-5 Acre	Single Family Res-Combo
99 114144 RK	R-5	Rural-5 Acre	Single Family Res-Combo
99 112688 RK	R-5	Rural-5 Acre	Single Family Res-Combo
99 104851 RK	R-5	Rural-5 Acre	Single Family Res-Combo
99 113363 RK	R-5	Rural-5 Acre	Single Family Res-Combo
99 114241 RK	R-5	Rural-5 Acre	Single Family Res-Combo
99 114240 RK	R-5	Rural-5 Acre	Single Family Res-Combo
99 114236 RK	R-5	Rural-5 Acre	Single Family Res-Combo
99 114449 RK	R-5	Rural-5 Acre	Single Family Res-Combo
99 113079 RK	R-5	Rural-5 Acre	Single Family Res-Combo
99 113085 RK	R-5	Rural-5 Acre	Single Family Res-Combo
99 104884 RK	R-5	Rural-5 Acre	Single Family Res-Combo

Accessory Dwelling Units

Index # - File Name: 1.0022 - Single Family Dwellings Data\_Snohomish County.pdf

99 111688 RK	PRD-20,000	Residential 20,000 sq. ft.	Single Family Res-Combo
99 114562 MH	CITY	City	Triple Wide
99 105037 MH	R-5	Rural-5 Acre	Triple Wide
99 105078 MH	R-5	Rural-5 Acre	Double Wide
99 105444 RK	R-5	Rural-5 Acre	SFR-Basic
99 110590 RK	R-5	Rural-5 Acre	Single Family Res-Combo
99 112075 RK	R-5	Rural-5 Acre	Single Family Res-Combo
99 109948 RK	R-5	Rural-5 Acre	Single Family Res-Combo
99 109950 RK	R-5	Rural-5 Acre	Single Family Res-Combo
99 111598 RK	R-5	Rural-5 Acre	Single Family Res-Combo
99 111982 RK	RC	Rural Conservation	Single Family Res-Combo
99 111539 RK	RC	Rural Conservation	Single Family Res-Combo
99 114973 RK	RC	Rural Conservation	Single Family Res-Combo
99 111980 RK	RC	Rural Conservation	Single Family Res-Combo
99 112519 RK	RC	Rural Conservation	Single Family Res-Combo
99 111979 RK	RC	Rural Conservation	Single Family Res-Combo
99 112521 RK	RC	Rural Conservation	SFR-Basic
99 113012 RK	RC	Rural Conservation	Single Family Res-Combo
99 111977 RK	RC	Rural Conservation	SFR-Basic
99 113013 RK	RC	Rural Conservation	Single Family Res-Combo
99 111981 RK	RC	Rural Conservation	Single Family Res-Combo
99 114665 RK	RC	Rural Conservation	Single Family Res-Combo
99 105226 RK	RC	Rural Conservation	Single Family Res-Combo
99 111765 RK	RC	Rural Conservation	Single Family Res-Combo
99 105026 RK	CITY	City	Single Family Res-Combo
99 103893 RK	CITY	City	Single Family Res-Combo
99 103891 RK	CITY	City	Single Family Res-Combo
99 102556 RK	R-5	Rural-5 Acre	SFR-Basic
99 110224 RK	CITY	City	SFR-Basic
99 102566 RK	R-5	Rural-5 Acre	Single Family Res-Combo
99 110007 RK	CITY	City	SFR-Basic
98 117031 RK	CITY	City	Single Family Res-Combo
99 101206 RK	CITY	City	Single Family Res-Combo
99 102572 RK	CITY	City	SFR-Basic
98 150521 RK	CITY	City	Single Family Res-Combo
99 102575 RK	CITY	City	SFR-Basic
99 102576 RK	CITY	City	SFR-Basic
99 102577 RK	CITY	City	SFR-Basic
99 102580 RK	CITY	City	SFR-Basic
99 103063 RK	CITY	City	SFR-Basic
99 103064 RK	CITY	City	SFR-Basic
99 103068 RK	CITY	City	SFR-Basic
99 103069 RK	CITY	City	SFR-Basic
99 103072 RK	CITY	City	SFR-Basic
99 103073 RK	CITY	City	SFR-Basic
99 104311 RK	CITY	City	SFR-Basic
99 110153 RK	CITY	City	SFR-Basic

Accessory Dwelling Units

Index # - File Name: 1.0022 - Single Family Dwellings Data\_Snohomish County.pdf

99 110152 RK	CITY	City	SFR-Basic
99 110357 RK	CITY	City	SFR-Basic
99 110361 RK	CITY	City	SFR-Basic
99 110958 RK	CITY	City	SFR-Basic
99 110955 RK	CITY	City	SFR-Basic
99 110956 RK	CITY	City	SFR-Basic
99 112364 RK	CITY	City	SFR-Basic
99 112366 RK	CITY	City	SFR-Basic
99 112568 RK	CITY	City	SFR-Basic
99 112565 RK	CITY	City	SFR-Basic
99 112569 RK	CITY	City	SFR-Basic
99 112570 RK	CITY	City	SFR-Basic
99 112766 RK	CITY	City	SFR-Basic
99 112768 RK	CITY	City	SFR-Basic
99 112769 RK	CITY	City	SFR-Basic
99 112772 RK	TRIBES	Native American Land	SFR-Basic
99 112774 RK	CITY	City	SFR-Basic
99 113080 RK	CITY	City	SFR-Basic
99 113084 RK	CITY	City	SFR-Basic
99 113081 RK	CITY	City	SFR-Basic
99 113082 RK	CITY	City	SFR-Basic
99 113083 RK	CITY	City	SFR-Basic
99 112367 RK	CITY	City	SFR-Basic
99 112368 RK	CITY	City	SFR-Basic
99 112571 RK	CITY	City	SFR-Basic
99 111477 RK	CITY	City	SFR-Basic
99 111475 RK	CITY	City	SFR-Basic
99 111476 RK	CITY	City	SFR-Basic
99 111474 RK	CITY	City	SFR-Basic
99 111478 RK	CITY	City	SFR-Basic
99 111127 RK	CITY	City	SFR-Basic
99 110959 RK	CITY	City	SFR-Basic
99 110957 RK	CITY	City	SFR-Basic
99 110360 RK	CITY	City	SFR-Basic
99 109341 RK	CITY	City	SFR-Basic
99 109304 RK	CITY	City	SFR-Basic
99 109302 RK	CITY	City	SFR-Basic
99 105465 RK	CITY	City	SFR-Basic
99 105469 RK	CITY	City	SFR-Basic
99 104504 RK	CITY	City	SFR-Basic
99 104505 RK	CITY	City	SFR-Basic
99 104306 RK	CITY	City	SFR-Basic
99 102578 RK	CITY	City	SFR-Basic
99 110008 RK	CITY	City	SFR-Basic
99 110226 RK	CITY	City	SFR-Basic
99 110989 RK	CITY	City	SFR-Basic
99 110029 RK	CITY	City	SFR-Basic

Accessory Dwelling Units

Index # - File Name: 1.0022 - Single Family Dwellings Data\_Snohomish County.pdf

99 103224 RK	CITY	City	SFR-Basic
99 103648 RK	CITY	City	Single Family Res-Combo
99 110130 RK	CITY	City	SFR-Basic
99 103222 RK	CITY	City	SFR-Basic
99 113332 RK	CITY	City	SFR-Basic
99 110129 RK	CITY	City	SFR-Basic
99 113328 RK	CITY	City	SFR-Basic
99 113329 RK	CITY	City	SFR-Basic
99 113330 RK	CITY	City	SFR-Basic
99 112230 RK	PRD-9,600	Residential 9,600 sq. ft.	SFR-Basic
99 111120 RK	R-5	Rural-5 Acre	Single Family Res-Combo
99 111566 RK	R-9,600	Residential 9,600 sq. ft.	Single Family Res-Combo
99 101222 RK	R-7,200	Residential 7,200 sq. ft.	Single Family Res-Combo
99 101224 RK	R-7,200	Residential 7,200 sq. ft.	Single Family Res-Combo
99 101933 RK	R-9,600	Residential 9,600 sq. ft.	Single Family Res-Combo
99 110881 RK	R-9,600	Residential 9,600 sq. ft.	Single Family Res-Combo
99 110882 RK	R-9,600	Residential 9,600 sq. ft.	Single Family Res-Combo
99 103206 RK	R-9,600	Residential 9,600 sq. ft.	SFR-Basic
99 101824 RK	R-9,600	Residential 9,600 sq. ft.	Single Family Res-Combo
99 101822 RK	R-9,600	Residential 9,600 sq. ft.	Single Family Res-Combo
99 101821 RK	R-9,600	Residential 9,600 sq. ft.	Single Family Res-Combo
99 105236 RK	R-9,600	Residential 9,600 sq. ft.	SFR-Basic
99 112601 RK	R-9,600	Residential 9,600 sq. ft.	SFR-Basic
99 103580 RK	R-9,600	Residential 9,600 sq. ft.	SFR-Basic
99 113801 RK	R-9,600	Residential 9,600 sq. ft.	Single Family Res-Combo
99 103584 RK	R-9,600	Residential 9,600 sq. ft.	SFR-Basic
99 101826 RK	R-9,600	Residential 9,600 sq. ft.	Single Family Res-Combo
99 103586 RK	R-9,600	Residential 9,600 sq. ft.	SFR-Basic
99 105047 RK	R-9,600	Residential 9,600 sq. ft.	SFR-Basic
99 103209 RK	R-9,600	Residential 9,600 sq. ft.	SFR-Basic
99 112599 RK	R-9,600	Residential 9,600 sq. ft.	SFR-Basic
99 105232 RK	R-9,600	Residential 9,600 sq. ft.	SFR-Basic
99 103585 RK	R-9,600	Residential 9,600 sq. ft.	SFR-Basic
99 101934 RK	R-9,600	Residential 9,600 sq. ft.	Single Family Res-Combo
99 102437 RK	R-9,600	Residential 9,600 sq. ft.	Single Family Res-Combo
99 102342 RK	R-9,600	Residential 9,600 sq. ft.	Single Family Res-Combo
99 102443 RK	R-9,600	Residential 9,600 sq. ft.	Single Family Res-Combo
99 102440 RK	R-9,600	Residential 9,600 sq. ft.	Single Family Res-Combo
99 103582 RK	R-9,600	Residential 9,600 sq. ft.	SFR-Basic
99 101935 RK	R-9,600	Residential 9,600 sq. ft.	Single Family Res-Combo
99 102441 RK	R-9,600	Residential 9,600 sq. ft.	Single Family Res-Combo
99 102343 RK	R-9,600	Residential 9,600 sq. ft.	Single Family Res-Combo
99 103578 RK	R-9,600	Residential 9,600 sq. ft.	SFR-Basic
99 111471 RK	CITY	City	SFR-Basic
99 110132 RK	CITY	City	SFR-Basic
99 111893 RK	CITY	City	SFR-Basic
99 111620 RK	CITY	City	SFR-Basic

Accessory Dwelling Units

Index # - File Name: 1.0022 - Single Family Dwellings Data\_Snohomish County.pdf

99 110127 RK	CITY	City	SFR-Basic
99 111470 RK	CITY	City	SFR-Basic
99 112672 RK	CITY	City	SFR-Basic
99 113334 RK	CITY	City	SFR-Basic
99 113335 RK	CITY	City	SFR-Basic
99 110369 RK	CITY	City	SFR-Basic
99 110380 RK	CITY	City	SFR-Basic
99 110381 RK	CITY	City	SFR-Basic
99 110370 RK	CITY	City	SFR-Basic
99 110375 RK	CITY	City	SFR-Basic
99 110377 RK	CITY	City	SFR-Basic
99 110371 RK	CITY	City	SFR-Basic
99 110378 RK	CITY	City	SFR-Basic
99 110372 RK	CITY	City	SFR-Basic
99 110382 RK	CITY	City	SFR-Basic
99 110373 RK	CITY	City	SFR-Basic
99 110383 RK	CITY	City	SFR-Basic
99 110384 RK	CITY	City	SFR-Basic
99 110374 RK	CITY	City	SFR-Basic
99 110385 RK	CITY	City	SFR-Basic
99 110379 RK	CITY	City	SFR-Basic
99 103454 RK	CITY	City	Single Family Res-Combo
99 103453 RK	CITY	City	Single Family Res-Combo
99 104696 RK	CITY	City	SFR-Basic
99 104715 RK	CITY	City	SFR-Basic
99 104975 RK	CITY	City	SFR-Basic
99 104583 RK	CITY	City	SFR-Basic
99 104595 RK	CITY	City	SFR-Basic
99 104699 RK	CITY	City	SFR-Basic
99 104594 RK	CITY	City	SFR-Basic
99 103505 RK	CITY	City	Single Family Res-Combo
99 103510 RK	CITY	City	Single Family Res-Combo
99 104974 RK	CITY	City	SFR-Basic
99 104611 RK	CITY	City	SFR-Basic
99 104613 RK	CITY	City	SFR-Basic
99 104614 RK	CITY	City	SFR-Basic
99 104700 RK	CITY	City	SFR-Basic
99 104615 RK	CITY	City	SFR-Basic
99 104714 RK	CITY	City	SFR-Basic
99 104616 RK	CITY	City	SFR-Basic
99 104617 RK	CITY	City	SFR-Basic
99 110133 RK	CITY	City	SFR-Basic
99 113331 RK	CITY	City	SFR-Basic
99 105001 RK	CITY	City	SFR-Basic
99 112671 RK	CITY	City	SFR-Basic
99 110031 RK	CITY	City	SFR-Basic
99 113336 RK	CITY	City	SFR-Basic

Accessory Dwelling Units

Index # - File Name: 1.0022 - Single Family Dwellings Data\_Snohomish County.pdf

99 102383 RK	CITY	City	Single Family Res-Combo
99 111621 RK	CITY	City	SFR-Basic
99 101223 RK	R-7,200	Residential 7,200 sq. ft.	Single Family Res-Combo
99 100397 RK	R-7,200	Residential 7,200 sq. ft.	Single Family Res-Combo
99 105235 RK	R-9,600	Residential 9,600 sq. ft.	SFR-Basic
99 109404 RK	R-5	Rural-5 Acre	Single Family Res-Combo
99 103601 RK	R-5	Rural-5 Acre	Single Family Res-Combo
99 114855 RK	R-7,200	Residential 7,200 sq. ft.	SFR-Basic
99 114857 RK	R-7,200	Residential 7,200 sq. ft.	SFR-Basic
99 114858 RK	R-7,200	Residential 7,200 sq. ft.	SFR-Basic
99 114347 RK	R-7,200	Residential 7,200 sq. ft.	SFR-Basic
99 114456 RK	R-7,200	Residential 7,200 sq. ft.	SFR-Basic
99 111452 RK	R-7,200	Residential 7,200 sq. ft.	SFR-Basic
99 111041 RK	R-7,200	Residential 7,200 sq. ft.	SFR-Basic
99 111039 RK	R-7,200	Residential 7,200 sq. ft.	SFR-Basic
99 111705 RK	R-7,200	Residential 7,200 sq. ft.	Single Family Res-Combo
99 111040 RK	R-7,200	Residential 7,200 sq. ft.	SFR-Basic
99 109318 RK	R-7,200	Residential 7,200 sq. ft.	SFR-Basic
99 110289 RK	R-7,200	Residential 7,200 sq. ft.	SFR-Basic
99 110809 RK	R-7,200	Residential 7,200 sq. ft.	SFR-Basic
99 110161 RK	R-7,200	Residential 7,200 sq. ft.	SFR-Basic
99 109320 RK	R-7,200	Residential 7,200 sq. ft.	SFR-Basic
99 110162 RK	R-7,200	Residential 7,200 sq. ft.	SFR-Basic
99 100832 RK	R-7,200	Residential 7,200 sq. ft.	Single Family Res-Combo
99 100833 RK	R-7,200	Residential 7,200 sq. ft.	Single Family Res-Combo
99 100395 RK	R-7,200	Residential 7,200 sq. ft.	Single Family Res-Combo
99 110288 RK	R-7,200	Residential 7,200 sq. ft.	SFR-Basic
99 104180 RK	R-7,200	Residential 7,200 sq. ft.	SFR-Basic
99 103202 RK	R-7,200	Residential 7,200 sq. ft.	SFR-Basic
99 104182 RK	R-7,200	Residential 7,200 sq. ft.	SFR-Basic
99 100396 RK	R-7,200	Residential 7,200 sq. ft.	Single Family Res-Combo
99 112605 RK	R-7,200	Residential 7,200 sq. ft.	SFR-Basic
99 103201 RK	R-7,200	Residential 7,200 sq. ft.	SFR-Basic
99 103203 RK	R-7,200	Residential 7,200 sq. ft.	SFR-Basic
99 101730 RK	R-7,200	Residential 7,200 sq. ft.	Single Family Res-Combo
99 111451 RK	R-7,200	Residential 7,200 sq. ft.	SFR-Basic
99 110163 RK	R-7,200	Residential 7,200 sq. ft.	SFR-Basic
99 115301 RK	R-7,200	Residential 7,200 sq. ft.	SFR-Basic
99 115306 RK	R-7,200	Residential 7,200 sq. ft.	SFR-Basic
99 103723 RK	R-5	Rural-5 Acre	Single Family Res-Combo
99 103725 RK	R-5	Rural-5 Acre	SFR-Basic
99 113603 RK	R-5	Rural-5 Acre	Single Family Res-Combo
99 105368 RK	R-5	Rural-5 Acre	Single Family Res-Combo
99 110488 RK	R-5	Rural-5 Acre	Single Family Res-Combo
99 109529 RK	R-5	Rural-5 Acre	Single Family Res-Combo
99 103721 RK	R-5	Rural-5 Acre	SFR-Basic
99 104184 RK	R-7,200	Residential 7,200 sq. ft.	SFR-Basic

Accessory Dwelling Units

Index # - File Name: 1.0022 - Single Family Dwellings Data\_Snohomish County.pdf

99 114274 RK	R-7,200	Residential 7,200 sq. ft.	SFR-Basic
99 114455 RK	R-7,200	Residential 7,200 sq. ft.	SFR-Basic
99 111050 RK	R-7,200	Residential 7,200 sq. ft.	Single Family Res-Combo
99 111037 RK	R-7,200	Residential 7,200 sq. ft.	SFR-Basic
99 111048 RK	R-7,200	Residential 7,200 sq. ft.	SFR-Basic
99 111046 RK	R-7,200	Residential 7,200 sq. ft.	SFR-Basic
99 112602 RK	R-7,200	Residential 7,200 sq. ft.	SFR-Basic
99 104183 RK	R-7,200	Residential 7,200 sq. ft.	SFR-Basic
99 103356 RK	R-7,200	Residential 7,200 sq. ft.	SFR-Basic
99 114350 RK	R-7,200	Residential 7,200 sq. ft.	SFR-Basic
99 101454 RK	R-7,200	Residential 7,200 sq. ft.	Single Family Res-Combo
99 110806 RK	R-7,200	Residential 7,200 sq. ft.	SFR-Basic
99 103358 RK	R-7,200	Residential 7,200 sq. ft.	SFR-Basic
99 104413 RK	R-7,200	Residential 7,200 sq. ft.	SFR-Basic
99 104179 RK	R-7,200	Residential 7,200 sq. ft.	SFR-Basic
99 104414 RK	R-7,200	Residential 7,200 sq. ft.	SFR-Basic
99 104416 RK	R-7,200	Residential 7,200 sq. ft.	SFR-Basic
99 104415 RK	R-7,200	Residential 7,200 sq. ft.	SFR-Basic
99 102428 RK	R-7,200	Residential 7,200 sq. ft.	Single Family Res-Combo
99 104411 RK	R-7,200	Residential 7,200 sq. ft.	SFR-Basic
99 103360 RK	R-7,200	Residential 7,200 sq. ft.	SFR-Basic
99 115305 RK	R-7,200	Residential 7,200 sq. ft.	SFR-Basic
99 115418 RK	R-7,200	Residential 7,200 sq. ft.	SFR-Basic
99 115304 RK	R-7,200	Residential 7,200 sq. ft.	SFR-Basic
99 115303 RK	R-7,200	Residential 7,200 sq. ft.	SFR-Basic
99 102889 MH	R-5	Rural-5 Acre	Double Wide
99 110395 RK	CITY	City	Duplex-Combo
99 103844 RK	CITY	City	Single Family Res-Combo
99 104976 RK	CITY	City	SFR-Basic
99 104743 RK	CITY	City	SFR-Basic
99 104716 RK	CITY	City	SFR-Basic
99 104644 RK	CITY	City	SFR-Basic
99 104646 RK	CITY	City	SFR-Basic
99 104739 RK	CITY	City	SFR-Basic
99 104742 RK	CITY	City	SFR-Basic
99 110138 RK	R-5	Rural-5 Acre	Single Family Res-Combo
99 113132 RK	R-5	Rural-5 Acre	Single Family Res-Combo
99 113135 RK	R-5	Rural-5 Acre	Single Family Res-Combo
99 103826 RK	R-5	Rural-5 Acre	Single Family Res-Combo
99 105072 RK	R-5	Rural-5 Acre	Single Family Res-Combo
99 105073 RK	R-5	Rural-5 Acre	Single Family Res-Combo
99 111985 RK	CITY	City	Single Family Res-Combo
99 111984 RK	CITY	City	SFR-Basic
99 111389 RK	CITY	City	Single Family Res-Combo
99 111434 RK	R-8,400	Residential 8,400 sq. ft.	Duplex-Combo
99 113491 RK	R-8,400	Residential 8,400 sq. ft.	Duplex-Basic
99 110607 MH	R-5	Rural-5 Acre	Double Wide

Accessory Dwelling Units

Index # - File Name: 1.0022 - Single Family Dwellings Data\_Snohomish County.pdf

99 110675 RK	PRD-7,200	Residential 7,200 sq. ft.	SFR-Basic
99 112020 RK	R-5	Rural-5 Acre	Single Family Res-Combo
99 102425 RK	R-8,400	Residential 8,400 sq. ft.	Single Family Res-Combo
98 150979 RK	R-8,400	Residential 8,400 sq. ft.	Single Family Res-Combo
98 151021 RK	R-8,400	Residential 8,400 sq. ft.	Single Family Res-Combo
99 111993 RK	PRD-7,200	Residential 7,200 sq. ft.	Single Family Res-Combo
99 112251 RK	PRD-7,200	Residential 7,200 sq. ft.	SFR-Basic
99 111991 RK	PRD-7,200	Residential 7,200 sq. ft.	SFR-Basic
99 111992 RK	PRD-7,200	Residential 7,200 sq. ft.	SFR-Basic
99 112253 RK	PRD-7,200	Residential 7,200 sq. ft.	SFR-Basic
99 111994 RK	PRD-7,200	Residential 7,200 sq. ft.	Single Family Res-Combo
99 112461 RK	PRD-7,200	Residential 7,200 sq. ft.	SFR-Basic
99 112460 RK	PRD-7,200	Residential 7,200 sq. ft.	SFR-Basic
99 113522 RK	PRD-7,200	Residential 7,200 sq. ft.	SFR-Basic
99 112462 RK	PRD-7,200	Residential 7,200 sq. ft.	SFR-Basic
99 112252 RK	PRD-7,200	Residential 7,200 sq. ft.	SFR-Basic
99 112254 RK	PRD-7,200	Residential 7,200 sq. ft.	SFR-Basic
99 110030 RK	CITY	City	Single Family Res-Combo
99 112332 RK	CITY	City	SFR-Basic
99 110032 RK	CITY	City	Single Family Res-Combo
99 112327 RK	CITY	City	SFR-Basic
99 112334 RK	CITY	City	SFR-Basic
99 112329 RK	CITY	City	SFR-Basic
99 112335 RK	CITY	City	SFR-Basic
99 112336 RK	CITY	City	SFR-Basic
99 112330 RK	CITY	City	SFR-Basic
99 110049 RK	CITY	City	Single Family Res-Combo
99 111109 RK	R-5	Rural-5 Acre	Single Family Res-Combo
99 111198 RK	R-5	Rural-5 Acre	Single Family Res-Combo
99 115248 RK	R-9,600	Residential 9,600 sq. ft.	SFR-Basic
99 113745 RK	R-9,600	Residential 9,600 sq. ft.	Single Family Res-Combo
99 114777 RK	R-9,600	Residential 9,600 sq. ft.	SFR-Basic
98 108095 RK	R-9,600	Residential 9,600 sq. ft.	Single Family Res-Combo
99 103546 RK	R-9,600	Residential 9,600 sq. ft.	Single Family Res-Combo
99 111237 RK	R-9,600	Residential 9,600 sq. ft.	SFR-Basic
98 109278 RK	R-9,600	Residential 9,600 sq. ft.	Single Family Res-Combo
99 111238 RK	R-9,600	Residential 9,600 sq. ft.	SFR-Basic
98 150812 RK	R-9,600	Residential 9,600 sq. ft.	Single Family Res-Combo
98 116332 RK	R-9,600	Residential 9,600 sq. ft.	Single Family Res-Combo
99 112044 RK	R-9,600	Residential 9,600 sq. ft.	SFR-Basic
99 111781 RK	R-9,600	Residential 9,600 sq. ft.	SFR-Basic
99 111997 RK	R-9,600	Residential 9,600 sq. ft.	SFR-Basic
99 112270 RK	R-9,600	Residential 9,600 sq. ft.	SFR-Basic
99 113746 RK	R-9,600	Residential 9,600 sq. ft.	Single Family Res-Combo
99 114463 RK	R-9,600	Residential 9,600 sq. ft.	SFR-Basic
99 113071 RK	R-9,600	Residential 9,600 sq. ft.	SFR-Basic
99 101497 RK	R-9,600	Residential 9,600 sq. ft.	Single Family Res-Combo



Accessory Dwelling Units

Index # - File Name: 1.0022 - Single Family Dwellings Data\_Snohomish County.pdf

99 113575 RK	R-9,600	Residential 9,600 sq. ft.	SFR-Basic
99 111585 RK	R-9,600	Residential 9,600 sq. ft.	Single Family Res-Combo
99 111779 RK	R-9,600	Residential 9,600 sq. ft.	SFR-Basic
98 107592 RK	R-9,600	Residential 9,600 sq. ft.	Single Family Res-Combo
99 111970 RK	R-9,600	Residential 9,600 sq. ft.	SFR-Basic
99 111972 RK	R-9,600	Residential 9,600 sq. ft.	SFR-Basic
99 112144 RK	R-9,600	Residential 9,600 sq. ft.	SFR-Basic
99 111491 RK	R-9,600	Residential 9,600 sq. ft.	SFR-Basic
99 111496 RK	R-9,600	Residential 9,600 sq. ft.	SFR-Basic
99 111494 RK	R-9,600	Residential 9,600 sq. ft.	SFR-Basic
99 111505 RK	R-9,600	Residential 9,600 sq. ft.	Single Family Res-Combo
98 108505 RK	R-9,600	Residential 9,600 sq. ft.	Single Family Res-Combo
99 111487 RK	R-9,600	Residential 9,600 sq. ft.	Single Family Res-Combo
99 112697 RK	R-9,600	Residential 9,600 sq. ft.	Single Family Res-Combo
99 111501 RK	R-9,600	Residential 9,600 sq. ft.	Single Family Res-Combo
99 114135 RK	R-9,600	Residential 9,600 sq. ft.	SFR-Basic
99 112041 RK	R-9,600	Residential 9,600 sq. ft.	SFR-Basic
98 116337 RK	R-9,600	Residential 9,600 sq. ft.	Single Family Res-Combo
98 110618 RK	R-9,600	Residential 9,600 sq. ft.	Single Family Res-Combo
99 111536 RK	R-9,600	Residential 9,600 sq. ft.	Single Family Res-Combo
98 109059 RK	R-9,600	Residential 9,600 sq. ft.	Single Family Res-Combo
99 113938 RK	PRD-7,200	Residential 7,200 sq. ft.	SFR-Basic
99 110215 RK	PRD-7,200	Residential 7,200 sq. ft.	SFR-Basic
99 110213 RK	PRD-7,200	Residential 7,200 sq. ft.	SFR-Basic
99 110209 RK	PRD-7,200	Residential 7,200 sq. ft.	SFR-Basic
99 110216 RK	PRD-7,200	Residential 7,200 sq. ft.	SFR-Basic
99 110208 RK	PRD-7,200	Residential 7,200 sq. ft.	SFR-Basic
99 110211 RK	PRD-7,200	Residential 7,200 sq. ft.	SFR-Basic
99 110217 RK	PRD-7,200	Residential 7,200 sq. ft.	SFR-Basic
99 110212 RK	PRD-7,200	Residential 7,200 sq. ft.	SFR-Basic
99 111718 RK	PRD-7,200	Residential 7,200 sq. ft.	SFR-Basic
99 109604 RK	PRD-7,200	Residential 7,200 sq. ft.	SFR-Basic
99 109606 RK	PRD-7,200	Residential 7,200 sq. ft.	SFR-Basic
99 109608 RK	PRD-7,200	Residential 7,200 sq. ft.	SFR-Basic
99 109607 RK	PRD-7,200	Residential 7,200 sq. ft.	SFR-Basic
99 109609 RK	PRD-7,200	Residential 7,200 sq. ft.	SFR-Basic
99 109603 RK	PRD-7,200	Residential 7,200 sq. ft.	SFR-Basic
99 109610 RK	PRD-7,200	Residential 7,200 sq. ft.	SFR-Basic
99 113301 RK	PRD-7,200	Residential 7,200 sq. ft.	SFR-Basic
99 113302 RK	PRD-7,200	Residential 7,200 sq. ft.	SFR-Basic
99 111722 RK	PRD-7,200	Residential 7,200 sq. ft.	SFR-Basic
99 111720 RK	PRD-7,200	Residential 7,200 sq. ft.	SFR-Basic
99 109414 RK	PRD-7,200	Residential 7,200 sq. ft.	SFR-Basic
99 109410 RK	PRD-7,200	Residential 7,200 sq. ft.	SFR-Basic
99 109411 RK	PRD-7,200	Residential 7,200 sq. ft.	SFR-Basic
99 109412 RK	PRD-7,200	Residential 7,200 sq. ft.	SFR-Basic
99 109415 RK	PRD-7,200	Residential 7,200 sq. ft.	SFR-Basic

Accessory Dwelling Units

Index # - File Name: 1.0022 - Single Family Dwellings Data\_Snohomish County.pdf

99 111721 RK	R-5	Rural-5 Acre	Single Family Res-Combo
99 111724 RK	R-5	Rural-5 Acre	Single Family Res-Combo
99 112395 RK	R-5	Rural-5 Acre	Single Family Res-Combo
99 111661 RK	R-5	Rural-5 Acre	Single Family Res-Combo
99 103892 RK	CITY	City	Single Family Res-Combo
99 103894 RK	CITY	City	Single Family Res-Combo
99 110874 RK	R-9,600	Residential 9,600 sq. ft.	Duplex-Basic
99 114269 RK	R-9,600	Residential 9,600 sq. ft.	Duplex-Basic
99 110873 RK	R-9,600	Residential 9,600 sq. ft.	Duplex-Basic
99 110865 RK	R-7,200	Residential 7,200 sq. ft.	Duplex-Basic
99 110871 RK	R-7,200	Residential 7,200 sq. ft.	Duplex-Basic
99 110388 RK	R-7,200	Residential 7,200 sq. ft.	Duplex-Combo
99 110864 RK	R-7,200	Residential 7,200 sq. ft.	Duplex-Basic
99 105183 MH	R-5	Rural-5 Acre	Double Wide
99 105202 MH	RRT-10	Rural Resource Transition-10	Triple Wide
99 113130 RK	CITY	City	Single Family Res-Combo
99 110574 RK	R-5	Rural-5 Acre	Single Family Res-Combo
98 150859 RK	CITY	City	Single Family Res-Combo
99 109914 RK	CITY	City	SFR-Basic
99 109921 RK	CITY	City	SFR-Basic
98 151052 RK	CITY	City	Single Family Res-Combo
99 109913 RK	CITY	City	SFR-Basic
99 112389 RK	CITY	City	SFR-Basic
98 150858 RK	CITY	City	Single Family Res-Combo
99 113866 RK	CITY	City	SFR-Basic
99 113181 RK	CITY	City	SFR-Basic
99 112388 RK	CITY	City	SFR-Basic
99 109915 RK	CITY	City	SFR-Basic
98 150860 RK	CITY	City	Single Family Res-Combo
99 109919 RK	CITY	City	SFR-Basic
99 109922 RK	CITY	City	SFR-Basic
99 109916 RK	CITY	City	SFR-Basic
99 109973 RK	CITY	City	Single Family Res-Combo
99 109980 RK	CITY	City	Single Family Res-Combo
99 109972 RK	CITY	City	Single Family Res-Combo
99 113178 RK	CITY	City	Single Family Res-Combo
99 109976 RK	CITY	City	Single Family Res-Combo
99 109974 RK	CITY	City	Single Family Res-Combo
99 109977 RK	CITY	City	Single Family Res-Combo
99 105083 RK	CITY	City	Single Family Res-Combo
99 105082 RK	CITY	City	Single Family Res-Combo
99 113750 RK	R-5	Rural-5 Acre	SFR-Basic
99 113748 RK	R-5	Rural-5 Acre	SFR-Basic
99 113751 RK	R-5	Rural-5 Acre	SFR-Basic
99 112556 RK	R-5	Rural-5 Acre	SFR-Basic
99 113749 RK	R-5	Rural-5 Acre	SFR-Basic
99 105470 RK	R-5	Rural-5 Acre	Single Family Res-Combo

Accessory Dwelling Units

Index # - File Name: 1.0022 - Single Family Dwellings Data\_Snohomish County.pdf

99 111220 RK	R-5	Rural-5 Acre	SFR-Basic
99 111221 RK	R-5	Rural-5 Acre	SFR-Basic
99 111222 RK	R-5	Rural-5 Acre	SFR-Basic
99 109542 RK	R-5	Rural-5 Acre	Single Family Res-Combo
99 109616 MH	RD	Rural Diversification	Double Wide
99 109663 RK	R-5	Rural-5 Acre	Single Family Res-Combo
99 109655 RK	R-5	Rural-5 Acre	Single Family Res-Combo
99 111223 RK	R-5	Rural-5 Acre	SFR-Basic
99 104618 RK	R-5	Rural-5 Acre	Single Family Res-Combo
99 111218 RK	R-5	Rural-5 Acre	SFR-Basic
99 110298 RK	R-5	Rural-5 Acre	Single Family Res-Combo
99 109891 MH	R-5	Rural-5 Acre	Single Wide
99 110714 RK	R-5	Rural-5 Acre	Single Family Res-Combo
99 111824 RK	R-5	Rural-5 Acre	Single Family Res-Combo
99 109777 MH	F	Forestry	Triple Wide
99 111594 RK	R-5	Rural-5 Acre	Single Family Res-Combo
99 112080 MH	RRT-10	Rural Resource Transition-10	Double Wide
99 113399 RK	F	Forestry	Single Family Res-Combo
99 111481 RK	PRD-9,600	Residential 9,600 sq. ft.	Single Family Res-Combo
99 112833 RK	PRD-9,600	Residential 9,600 sq. ft.	Single Family Res-Combo
99 111667 RK	PRD-9,600	Residential 9,600 sq. ft.	SFR-Basic
99 104018 RK	PRD-9,600	Residential 9,600 sq. ft.	Single Family Res-Combo
99 110309 RK	PRD-9,600	Residential 9,600 sq. ft.	SFR-Basic
99 110446 RK	PRD-9,600	Residential 9,600 sq. ft.	Single Family Res-Combo
99 111768 RK	PRD-9,600	Residential 9,600 sq. ft.	SFR-Basic
99 110121 MH	R-5	Rural-5 Acre	Triple Wide
99 112586 MH	R-5	Rural-5 Acre	Triple Wide
99 110144 RK	R-5	Rural-5 Acre	Single Family Res-Combo
99 110444 RK	PRD-9,600	Residential 9,600 sq. ft.	SFR-Basic
99 111005 RK	PRD-9,600	Residential 9,600 sq. ft.	SFR-Basic
99 111940 RK	PRD-9,600	Residential 9,600 sq. ft.	SFR-Basic
99 111509 RK	PRD-9,600	Residential 9,600 sq. ft.	Single Family Res-Combo
99 110445 RK	PRD-9,600	Residential 9,600 sq. ft.	SFR-Basic
99 110396 MH	RD	Rural Diversification	Double Wide
99 103679 RK	R-5	Rural-5 Acre	Single Family Res-Combo
99 103676 RK	R-5	Rural-5 Acre	Single Family Res-Combo
98 106652 RK	R-9,600	Residential 9,600 sq. ft.	Single Family Res-Combo
98 151029 RK	R-9,600	Residential 9,600 sq. ft.	Single Family Res-Combo
99 101993 RK	R-9,600	Residential 9,600 sq. ft.	Single Family Res-Combo
99 112616 RK	R-9,600	Residential 9,600 sq. ft.	Single Family Res-Combo
99 111967 RK	R-9,600	Residential 9,600 sq. ft.	Single Family Res-Combo
99 112618 RK	R-9,600	Residential 9,600 sq. ft.	Single Family Res-Combo
99 111809 RK	R-9,600	Residential 9,600 sq. ft.	SFR-Basic
99 111978 RK	R-9,600	Residential 9,600 sq. ft.	SFR-Basic
99 111807 RK	R-9,600	Residential 9,600 sq. ft.	SFR-Basic
99 114465 RK	R-9,600	Residential 9,600 sq. ft.	SFR-Basic
99 113072 RK	R-9,600	Residential 9,600 sq. ft.	SFR-Basic

Accessory Dwelling Units

Index # - File Name: 1.0022 - Single Family Dwellings Data\_Snohomish County.pdf

99 111584 RK	R-5	Rural-5 Acre	Single Family Res-Combo
99 113911 RK	R-7,200	Residential 7,200 sq. ft.	SFR-Basic
99 111668 RK	R-7,200	Residential 7,200 sq. ft.	Single Family Res-Combo
99 111402 RK	R-5	Rural-5 Acre	SFR-Basic
99 112623 RK	PRD-7,200	Residential 7,200 sq. ft.	SFR-Basic
99 112622 RK	PRD-7,200	Residential 7,200 sq. ft.	SFR-Basic
99 112624 RK	PRD-7,200	Residential 7,200 sq. ft.	SFR-Basic
99 112625 RK	PRD-7,200	Residential 7,200 sq. ft.	SFR-Basic
99 112626 RK	PRD-7,200	Residential 7,200 sq. ft.	SFR-Basic
99 112627 RK	PRD-7,200	Residential 7,200 sq. ft.	SFR-Basic
99 112628 RK	PRD-7,200	Residential 7,200 sq. ft.	SFR-Basic
99 112629 RK	PRD-7,200	Residential 7,200 sq. ft.	SFR-Basic
99 111518 RK	R-20,000	Residential 20,000 sq. ft.	Single Family Res-Combo
99 111235 RK	R-9,600	Residential 9,600 sq. ft.	SFR-Basic
99 111233 RK	R-9,600	Residential 9,600 sq. ft.	SFR-Basic
99 111234 RK	R-9,600	Residential 9,600 sq. ft.	SFR-Basic
99 111232 RK	R-9,600	Residential 9,600 sq. ft.	SFR-Basic
99 111236 RK	R-9,600	Residential 9,600 sq. ft.	SFR-Basic
99 113753 RK	R-7,200	Residential 7,200 sq. ft.	Single Family Res-Combo
99 111592 MH	R-5	Rural-5 Acre	Double Wide
99 113364 RK	PRD-8,400	Residential 8,400 sq. ft.	SFR-Basic
99 113362 RK	PRD-8,400	Residential 8,400 sq. ft.	SFR-Basic
99 111673 RK	PRD-8,400	Residential 8,400 sq. ft.	Single Family Res-Combo
99 111670 RK	PRD-8,400	Residential 8,400 sq. ft.	Single Family Res-Combo
99 114466 RK	PRD-8,400	Residential 8,400 sq. ft.	SFR-Basic
99 114467 RK	PRD-8,400	Residential 8,400 sq. ft.	SFR-Basic
99 111657 RK	A-10 : R-5	Agriculture-10 Acre : Rural-5	Single Family Res-Combo
99 116117 RK	PRD-8,400	Residential 8,400 sq. ft.	SFR-Basic
99 115569 RK	PRD-8,400	Residential 8,400 sq. ft.	SFR-Basic
99 116111 RK	PRD-8,400	Residential 8,400 sq. ft.	SFR-Basic
99 111674 RK	PRD-8,400	Residential 8,400 sq. ft.	Single Family Res-Combo
99 111380 MH	R-5	Rural-5 Acre	Double Wide
99 113204 RK	R-5	Rural-5 Acre	Single Family Res-Combo
99 111999 RK	R-5	Rural-5 Acre	SFR-Basic
99 112064 RK	R-9,600	Residential 9,600 sq. ft.	Single Family Res-Combo
99 112178 MH	R-5	Rural-5 Acre	MH Park-Double Wide
99 112217 RK	CITY	City	Single Family Res-Combo
99 112437 RK	R-5	Rural-5 Acre	Single Family Res-Combo
99 112552 RK	CITY	City	Single Family Res-Combo
99 112689 RK	R-5	Rural-5 Acre	SFR-Basic
99 114107 RK	R-9,600	Residential 9,600 sq. ft.	Single Family Res-Combo
99 111014 RK	R-5	Rural-5 Acre	Single Family Res-Combo
99 111013 RK	R-5	Rural-5 Acre	Single Family Res-Combo
99 111015 RK	R-5	Rural-5 Acre	Single Family Res-Combo
99 113602 RK	R-5	Rural-5 Acre	SFR-Basic
99 114332 RK	CITY	City	Single Family Res-Combo
99 112837 RK	R-7,200	Residential 7,200 sq. ft.	Single Family Res-Combo

Accessory Dwelling Units

Index # - File Name: 1.0022 - Single Family Dwellings Data\_Snohomish County.pdf

99 114884 RK	PRD-9,600	Residential 9,600 sq. ft.	SFR-Basic
99 114879 RK	PRD-9,600	Residential 9,600 sq. ft.	SFR-Basic
99 114882 RK	PRD-9,600	Residential 9,600 sq. ft.	SFR-Basic
99 114880 RK	PRD-9,600	Residential 9,600 sq. ft.	SFR-Basic
99 114891 RK	PRD-9,600	Residential 9,600 sq. ft.	SFR-Basic
99 114888 RK	PRD-9,600	Residential 9,600 sq. ft.	SFR-Basic
99 114887 RK	PRD-9,600	Residential 9,600 sq. ft.	SFR-Basic
99 114881 RK	PRD-9,600	Residential 9,600 sq. ft.	SFR-Basic
99 114892 RK	PRD-9,600	Residential 9,600 sq. ft.	SFR-Basic
99 114889 RK	PRD-9,600	Residential 9,600 sq. ft.	SFR-Basic
99 114885 RK	PRD-9,600	Residential 9,600 sq. ft.	SFR-Basic
99 113711 RK	PRD-9,600	Residential 9,600 sq. ft.	SFR-Basic
99 113713 RK	PRD-9,600	Residential 9,600 sq. ft.	SFR-Basic
99 113714 RK	PRD-9,600	Residential 9,600 sq. ft.	SFR-Basic
99 113716 RK	PRD-9,600	Residential 9,600 sq. ft.	SFR-Basic
99 113712 RK	PRD-9,600	Residential 9,600 sq. ft.	SFR-Basic
99 113053 RK	PRD-9,600	Residential 9,600 sq. ft.	SFR-Basic
99 113055 RK	PRD-9,600	Residential 9,600 sq. ft.	SFR-Basic
99 113054 RK	PRD-9,600	Residential 9,600 sq. ft.	SFR-Basic
99 113057 RK	PRD-9,600	Residential 9,600 sq. ft.	SFR-Basic
99 113058 RK	PRD-9,600	Residential 9,600 sq. ft.	SFR-Basic
99 113059 RK	PRD-9,600	Residential 9,600 sq. ft.	SFR-Basic
99 113060 RK	PRD-9,600	Residential 9,600 sq. ft.	SFR-Basic
99 112849 RK	PRD-9,600	Residential 9,600 sq. ft.	SFR-Basic
99 112850 RK	PRD-9,600	Residential 9,600 sq. ft.	SFR-Basic
99 112852 RK	PRD-9,600	Residential 9,600 sq. ft.	SFR-Basic
99 112854 RK	PRD-9,600	Residential 9,600 sq. ft.	SFR-Basic
99 112853 RK	PRD-9,600	Residential 9,600 sq. ft.	SFR-Basic
99 112855 RK	PRD-9,600	Residential 9,600 sq. ft.	SFR-Basic
99 112856 RK	PRD-9,600	Residential 9,600 sq. ft.	SFR-Basic
99 112858 RK	PRD-9,600	Residential 9,600 sq. ft.	SFR-Basic
99 112859 RK	PRD-9,600	Residential 9,600 sq. ft.	SFR-Basic
99 112862 RK	PRD-9,600	Residential 9,600 sq. ft.	SFR-Basic
99 112864 RK	PRD-9,600	Residential 9,600 sq. ft.	SFR-Basic
99 112865 RK	PRD-9,600	Residential 9,600 sq. ft.	SFR-Basic
99 112866 RK	PRD-9,600	Residential 9,600 sq. ft.	SFR-Basic
99 114033 RK	PRD-9,600	Residential 9,600 sq. ft.	SFR-Basic
99 114024 RK	PRD-9,600	Residential 9,600 sq. ft.	SFR-Basic
99 114027 RK	PRD-9,600	Residential 9,600 sq. ft.	SFR-Basic
99 114030 RK	PRD-9,600	Residential 9,600 sq. ft.	SFR-Basic
99 114032 RK	PRD-9,600	Residential 9,600 sq. ft.	SFR-Basic
99 114031 RK	PRD-9,600	Residential 9,600 sq. ft.	SFR-Basic
99 114025 RK	PRD-9,600	Residential 9,600 sq. ft.	SFR-Basic
99 114034 RK	PRD-9,600	Residential 9,600 sq. ft.	SFR-Basic
99 114029 RK	PRD-9,600	Residential 9,600 sq. ft.	SFR-Basic
99 115844 RK	PRD-9,600	Residential 9,600 sq. ft.	Single Family Res-Combo
99 112921 RK	R-5	Rural-5 Acre	Single Family Res-Combo

Accessory Dwelling Units

Index # - File Name: 1.0022 - Single Family Dwellings Data\_Snohomish County.pdf

99 113062 MH	R-7,200	Residential 7,200 sq. ft.	Triple Wide
99 113115 MH	R-5	Rural-5 Acre	Double Wide
99 112092 RK	PRD SA-1	Suburban Agriculture-1 Acre	Single Family Res-Combo
99 112093 RK	PRD SA-1	Suburban Agriculture-1 Acre	Single Family Res-Combo
99 112086 RK	PRD SA-1	Suburban Agriculture-1 Acre	SFR-Basic
99 112088 RK	PRD SA-1	Suburban Agriculture-1 Acre	Single Family Res-Combo
99 112090 RK	PRD SA-1	Suburban Agriculture-1 Acre	SFR-Basic
99 114475 RK	PRD SA-1	Suburban Agriculture-1 Acre	Single Family Res-Combo
99 112096 RK	PRD SA-1	Suburban Agriculture-1 Acre	Single Family Res-Combo
99 113066 RK	PRD SA-1	Suburban Agriculture-1 Acre	Single Family Res-Combo
99 112087 RK	PRD SA-1	Suburban Agriculture-1 Acre	SFR-Basic
99 114437 RK	PRD SA-1	Suburban Agriculture-1 Acre	Single Family Res-Combo
99 114438 RK	PRD SA-1	Suburban Agriculture-1 Acre	Single Family Res-Combo
99 113397 RK	PRD SA-1	Suburban Agriculture-1 Acre	SFR-Basic
99 113395 RK	PRD SA-1	Suburban Agriculture-1 Acre	SFR-Basic
99 113123 MH	R-12,500	Residential 12,500 sq. ft.	Double Wide
99 113258 RK	PRD-9,600	Residential 9,600 sq. ft.	SFR-Basic
99 113266 RK	PRD-9,600	Residential 9,600 sq. ft.	SFR-Basic
99 113259 RK	PRD-9,600	Residential 9,600 sq. ft.	SFR-Basic
99 113267 RK	PRD-9,600	Residential 9,600 sq. ft.	SFR-Basic
99 113260 RK	PRD-9,600	Residential 9,600 sq. ft.	SFR-Basic
99 113262 RK	PRD-9,600	Residential 9,600 sq. ft.	SFR-Basic
99 114599 RK	PRD-9,600	Residential 9,600 sq. ft.	SFR-Basic
99 113268 RK	PRD-9,600	Residential 9,600 sq. ft.	SFR-Basic
99 113264 RK	PRD-9,600	Residential 9,600 sq. ft.	SFR-Basic
99 114601 RK	PRD-9,600	Residential 9,600 sq. ft.	SFR-Basic
99 114603 RK	PRD-9,600	Residential 9,600 sq. ft.	Single Family Res-Combo
99 114602 RK	PRD-9,600	Residential 9,600 sq. ft.	SFR-Basic
99 113269 RK	PRD-9,600	Residential 9,600 sq. ft.	SFR-Basic
99 113261 RK	PRD-9,600	Residential 9,600 sq. ft.	SFR-Basic
99 114598 RK	PRD-9,600	Residential 9,600 sq. ft.	SFR-Basic
99 114600 RK	PRD-9,600	Residential 9,600 sq. ft.	SFR-Basic
99 113861 RK	R-5	Rural-5 Acre	Single Family Res-Combo
99 114105 RK	R-7,200	Residential 7,200 sq. ft.	Single Family Res-Combo
99 113570 RK	LDMR	Low Density Multiple Reside	Duplex-Basic
99 115300 RK	PRD-9,600	Residential 9,600 sq. ft.	Single Family Res-Combo
99 115358 RK	PRD-9,600	Residential 9,600 sq. ft.	Single Family Res-Combo
99 113734 RK	PRD-9,600	Residential 9,600 sq. ft.	SFR-Basic
99 113370 RK	PRD-9,600	Residential 9,600 sq. ft.	Single Family Res-Combo
99 113868 RK	PRD-9,600	Residential 9,600 sq. ft.	Single Family Res-Combo
99 113369 RK	PRD-9,600	Residential 9,600 sq. ft.	Single Family Res-Combo
99 115362 RK	PRD-9,600	Residential 9,600 sq. ft.	Single Family Res-Combo
99 114405 RK	PRD-9,600	Residential 9,600 sq. ft.	Single Family Res-Combo
99 115894 RK	PRD-9,600	Residential 9,600 sq. ft.	SFR-Basic
99 113871 RK	PRD-9,600	Residential 9,600 sq. ft.	SFR-Basic
99 111949 RK	PRD-9,600	Residential 9,600 sq. ft.	Single Family Res-Combo
99 111948 RK	PRD-9,600	Residential 9,600 sq. ft.	Single Family Res-Combo

Accessory Dwelling Units

Index # - File Name: 1.0022 - Single Family Dwellings Data\_Snohomish County.pdf

99 115361 RK	PRD-9,600	Residential 9,600 sq. ft.	SFR-Basic
99 111950 RK	PRD-9,600	Residential 9,600 sq. ft.	Single Family Res-Combo
99 115231 RK	PRD-9,600	Residential 9,600 sq. ft.	SFR-Basic
99 111990 RK	PRD-9,600	Residential 9,600 sq. ft.	Single Family Res-Combo
99 113735 RK	PRD-9,600	Residential 9,600 sq. ft.	SFR-Basic
99 115299 RK	PRD-9,600	Residential 9,600 sq. ft.	Single Family Res-Combo
99 113732 RK	PRD-9,600	Residential 9,600 sq. ft.	SFR-Basic
99 113733 RK	PRD-9,600	Residential 9,600 sq. ft.	SFR-Basic
99 113371 RK	PRD-9,600	Residential 9,600 sq. ft.	Single Family Res-Combo
99 114986 RK	PRD-9,600	Residential 9,600 sq. ft.	Single Family Res-Combo
99 114985 RK	PRD-9,600	Residential 9,600 sq. ft.	SFR-Basic
99 114394 RK	PRD-9,600	Residential 9,600 sq. ft.	SFR-Basic
99 114396 RK	PRD-9,600	Residential 9,600 sq. ft.	SFR-Basic
99 114234 MH	R-5	Rural-5 Acre	Double Wide
99 114065 RK	PRD-9,600	Residential 9,600 sq. ft.	SFR-Basic
99 114062 RK	PRD-9,600	Residential 9,600 sq. ft.	SFR-Basic
99 114060 RK	PRD-9,600	Residential 9,600 sq. ft.	SFR-Basic
99 114066 RK	PRD-9,600	Residential 9,600 sq. ft.	SFR-Basic
99 114070 RK	PRD-9,600	Residential 9,600 sq. ft.	SFR-Basic
99 114063 RK	PRD-9,600	Residential 9,600 sq. ft.	SFR-Basic
99 114071 RK	PRD-9,600	Residential 9,600 sq. ft.	SFR-Basic
99 114067 RK	PRD-9,600	Residential 9,600 sq. ft.	SFR-Basic
99 113368 RK	PRD-9,600	Residential 9,600 sq. ft.	Single Family Res-Combo
99 113854 RK	R-8,400	Residential 8,400 sq. ft.	SFR-Basic
99 113848 RK	R-8,400	Residential 8,400 sq. ft.	SFR-Basic
99 113851 RK	R-8,400	Residential 8,400 sq. ft.	SFR-Basic
99 113840 MH	RD	Rural Diversification	Double Wide
99 114314 RK	PRD-9,600 : R-	Residential 9,600 sq. ft.	Duplex-Basic
99 114390 RK	R-9,600	Residential 9,600 sq. ft.	SFR-Basic
99 114392 RK	R-9,600	Residential 9,600 sq. ft.	SFR-Basic
99 114391 RK	R-9,600	Residential 9,600 sq. ft.	SFR-Basic
99 114225 RK	R-9,600	Residential 9,600 sq. ft.	SFR-Basic
99 114224 RK	R-9,600	Residential 9,600 sq. ft.	SFR-Basic
99 114352 RK	R-5	Rural-5 Acre	Single Family Res-Combo
99 114389 MH	R-5	Rural-5 Acre	MH Park-Double Wide
99 114393 MH	R-5	Rural-5 Acre	MH Park-Double Wide
99 114909 RK	R-5	Rural-5 Acre	Single Family Res-Combo
99 114565 RK	R-5	Rural-5 Acre	Single Family Res-Combo
99 114606 RK	R-5	Rural-5 Acre	Single Family Res-Combo
99 115566 RK	R-7,200	Residential 7,200 sq. ft.	SFR-Basic
99 115565 RK	R-7,200	Residential 7,200 sq. ft.	SFR-Basic
99 109622 RK	R-7,200	Residential 7,200 sq. ft.	Single Family Res-Combo
99 115564 RK	R-7,200	Residential 7,200 sq. ft.	SFR-Basic
99 115560 RK	R-7,200	Residential 7,200 sq. ft.	SFR-Basic
99 114672 RK	R-7,200	Residential 7,200 sq. ft.	SFR-Basic
99 103204 RK	R-7,200	Residential 7,200 sq. ft.	Single Family Res-Combo
99 114667 RK	R-7,200	Residential 7,200 sq. ft.	SFR-Basic

Accessory Dwelling Units

Index # - File Name: 1.0022 - Single Family Dwellings Data\_Snohomish County.pdf

99 114668 RK	R-7,200	Residential 7,200 sq. ft.	SFR-Basic
99 113428 RK	R-7,200	Residential 7,200 sq. ft.	Single Family Res-Combo
99 115709 RK	R-7,200	Residential 7,200 sq. ft.	Single Family Res-Combo
99 115509 RK	CITY	City	SFR-Basic
99 115510 RK	CITY	City	SFR-Basic
99 115511 RK	CITY	City	SFR-Basic
99 115512 RK	CITY	City	SFR-Basic
99 115513 RK	CITY	City	SFR-Basic
99 115514 RK	CITY	City	SFR-Basic
99 114619 RK	CITY	City	Duplex-Combo
99 114559 RK	R-8,400	Residential 8,400 sq. ft.	SFR-Basic
99 114841 RK	R-8,400	Residential 8,400 sq. ft.	Single Family Res-Combo
99 114838 RK	R-8,400	Residential 8,400 sq. ft.	Single Family Res-Combo
99 114839 RK	R-8,400	Residential 8,400 sq. ft.	Single Family Res-Combo
99 113597 RK	CITY	City	Single Family Res-Combo
99 115504 RK	CITY	City	SFR-Basic
99 115505 RK	CITY	City	SFR-Basic
99 115506 RK	CITY	City	SFR-Basic
99 115507 RK	CITY	City	SFR-Basic
99 115229 RK	R-8,400	Residential 8,400 sq. ft.	SFR-Basic
99 115227 RK	R-8,400	Residential 8,400 sq. ft.	SFR-Basic
99 115388 RK	CITY	City	SFR-Basic
99 115065 RK	CITY	City	SFR-Basic
99 115067 RK	CITY	City	SFR-Basic
99 115662 RK	CITY	City	SFR-Basic
99 115068 RK	CITY	City	SFR-Basic
99 115069 RK	CITY	City	SFR-Basic
99 115663 RK	CITY	City	SFR-Basic
99 115661 RK	CITY	City	SFR-Basic
99 115384 RK	CITY	City	Single Family Res-Combo
99 115488 RK	R-7,200	Residential 7,200 sq. ft.	SFR-Basic
99 115487 RK	R-7,200	Residential 7,200 sq. ft.	SFR-Basic
99 115497 RK	R-7,200	Residential 7,200 sq. ft.	SFR-Basic
99 115500 RK	R-7,200	Residential 7,200 sq. ft.	SFR-Basic
99 115491 RK	R-7,200	Residential 7,200 sq. ft.	SFR-Basic
99 115499 RK	R-7,200	Residential 7,200 sq. ft.	SFR-Basic
99 115485 RK	R-7,200	Residential 7,200 sq. ft.	SFR-Basic
99 115484 RK	R-7,200	Residential 7,200 sq. ft.	SFR-Basic
99 115486 RK	R-7,200	Residential 7,200 sq. ft.	SFR-Basic
99 115591 RK	PRD-9,600	Residential 9,600 sq. ft.	SFR-Basic
99 115593 RK	PRD-9,600	Residential 9,600 sq. ft.	Single Family Res-Combo
99 116061 RK	PRD-9,600	Residential 9,600 sq. ft.	SFR-Basic
99 115596 RK	PRD-9,600	Residential 9,600 sq. ft.	Single Family Res-Combo
99 116062 RK	PRD-9,600	Residential 9,600 sq. ft.	SFR-Basic
99 115104 RK	PRD-7,200	Residential 7,200 sq. ft.	Single Family Res-Combo
99 114878 RK	PRD-7,200	Residential 7,200 sq. ft.	Single Family Res-Combo
99 114876 RK	PRD-7,200	Residential 7,200 sq. ft.	Single Family Res-Combo



Accessory Dwelling Units

Index # - File Name: 1.0022 - Single Family Dwellings Data\_Snohomish County.pdf

99 114877 RK	PRD-7,200	Residential 7,200 sq. ft.	Single Family Res-Combo
99 116070 RK	R-7,200	Residential 7,200 sq. ft.	SFR-Basic
99 115699 RK	R-7,200	Residential 7,200 sq. ft.	SFR-Basic
99 116071 RK	R-7,200	Residential 7,200 sq. ft.	SFR-Basic
99 116072 RK	R-7,200	Residential 7,200 sq. ft.	SFR-Basic
99 115701 RK	R-7,200	Residential 7,200 sq. ft.	SFR-Basic
98 108511 RK	R-5	Rural-5 Acre	Single Family Res-Combo
00 101640 RK	CITY	City	SFR-Basic
00 104181 RK	R-5	Rural-5 Acre	Single Family Res-Combo
00 106543 RK	R-5	Rural-5 Acre	Single Family Res-Combo
00 107663 MH	A-10	Agriculture-10 Acre	Double Wide
00 102224 RK	R-5	Rural-5 Acre	Single Family Res-Combo
00 104525 RK	R-5	Rural-5 Acre	Duplex-Combo
00 103396 RK	R-7,200	Residential 7,200 sq. ft.	Single Family Res-Combo
00 102165 MH	R-5	Rural-5 Acre	Triple Wide
00 107357 RK	CITY	City	SFR-Basic
00 107358 RK	CITY	City	SFR-Basic
00 107359 RK	CITY	City	SFR-Basic
00 105625 MH	R-5	Rural-5 Acre	Double Wide
00 103761 MH	R-5	Rural-5 Acre	Double Wide
00 105146 RK	R-9,600	Residential 9,600 sq. ft.	SFR-Basic
00 102214 RK	R-9,600	Residential 9,600 sq. ft.	SFR-Basic
00 107258 RK	R-9,600	Residential 9,600 sq. ft.	SFR-Basic
00 106664 RK	R-9,600	Residential 9,600 sq. ft.	SFR-Basic
00 109668 RK	R-9,600	Residential 9,600 sq. ft.	SFR-Basic
00 106665 RK	R-9,600	Residential 9,600 sq. ft.	SFR-Basic
00 106862 RK	R-9,600	Residential 9,600 sq. ft.	SFR-Basic
00 106863 RK	R-9,600	Residential 9,600 sq. ft.	SFR-Basic
00 106031 RK	R-9,600	Residential 9,600 sq. ft.	Single Family Res-Combo
00 105147 RK	R-9,600	Residential 9,600 sq. ft.	SFR-Basic
00 109060 RK	R-9,600	Residential 9,600 sq. ft.	SFR-Basic
00 108620 RK	R-9,600	Residential 9,600 sq. ft.	SFR-Basic
00 106415 RK	R-9,600	Residential 9,600 sq. ft.	SFR-Basic
00 109061 RK	R-9,600	Residential 9,600 sq. ft.	SFR-Basic
00 108621 RK	R-9,600	Residential 9,600 sq. ft.	SFR-Basic
00 102023 RK	R-9,600	Residential 9,600 sq. ft.	SFR-Basic
00 103057 RK	R-9,600	Residential 9,600 sq. ft.	SFR-Basic
00 102215 RK	R-9,600	Residential 9,600 sq. ft.	SFR-Basic
00 102029 RK	R-9,600	Residential 9,600 sq. ft.	SFR-Basic
00 104292 RK	R-9,600	Residential 9,600 sq. ft.	SFR-Basic
00 102024 RK	R-9,600	Residential 9,600 sq. ft.	SFR-Basic
00 102030 RK	R-9,600	Residential 9,600 sq. ft.	SFR-Basic
00 102031 RK	R-9,600	Residential 9,600 sq. ft.	SFR-Basic
00 102027 RK	R-9,600	Residential 9,600 sq. ft.	SFR-Basic
00 102025 RK	R-9,600	Residential 9,600 sq. ft.	SFR-Basic
00 102032 RK	R-9,600	Residential 9,600 sq. ft.	SFR-Basic
00 109962 RK	R-9,600	Residential 9,600 sq. ft.	SFR-Basic

Accessory Dwelling Units

Index # - File Name: 1.0022 - Single Family Dwellings Data\_Snohomish County.pdf

00 102033 RK	R-9,600	Residential 9,600 sq. ft.	SFR-Basic
00 102028 RK	R-9,600	Residential 9,600 sq. ft.	SFR-Basic
00 103689 RK	R-9,600	Residential 9,600 sq. ft.	SFR-Basic
98 109553 RK	R-9,600	Residential 9,600 sq. ft.	Single Family Res-Combo
00 108819 RK	R-9,600	Residential 9,600 sq. ft.	SFR-Basic
00 104870 RK	R-9,600	Residential 9,600 sq. ft.	SFR-Basic
00 106030 RK	R-9,600	Residential 9,600 sq. ft.	Single Family Res-Combo
00 104869 RK	R-9,600	Residential 9,600 sq. ft.	Single Family Res-Combo
00 102407 RK	R-9,600	Residential 9,600 sq. ft.	SFR-Basic
00 102026 RK	R-9,600	Residential 9,600 sq. ft.	SFR-Basic
00 102034 RK	R-9,600	Residential 9,600 sq. ft.	SFR-Basic
00 102408 RK	R-9,600	Residential 9,600 sq. ft.	SFR-Basic
00 102410 RK	R-9,600	Residential 9,600 sq. ft.	SFR-Basic
00 103885 RK	R-9,600	Residential 9,600 sq. ft.	Single Family Res-Combo
00 102116 RK	R-5	Rural-5 Acre	SFR-Basic
00 107471 RK	R-7,200	Residential 7,200 sq. ft.	Single Family Res-Combo
00 107475 RK	R-7,200	Residential 7,200 sq. ft.	Single Family Res-Combo
00 102704 RK	R-5	Rural-5 Acre	Single Family Res-Combo
00 110002 RK	R-5	Rural-5 Acre	SFR-Basic
00 102696 RK	R-5	Rural-5 Acre	Single Family Res-Combo
00 102710 MH	R-5	Rural-5 Acre	Double Wide
00 107783 RK	R-7,200	Residential 7,200 sq. ft.	SFR-Basic
00 107778 RK	R-7,200	Residential 7,200 sq. ft.	SFR-Basic
00 107780 RK	R-7,200	Residential 7,200 sq. ft.	SFR-Basic
00 107301 RK	R-7,200	Residential 7,200 sq. ft.	SFR-Basic
00 107305 RK	R-7,200	Residential 7,200 sq. ft.	SFR-Basic
00 107304 RK	R-7,200	Residential 7,200 sq. ft.	SFR-Basic
00 107303 RK	R-7,200	Residential 7,200 sq. ft.	SFR-Basic
00 107307 RK	R-7,200	Residential 7,200 sq. ft.	SFR-Basic
00 108651 RK	R-7,200	Residential 7,200 sq. ft.	SFR-Basic
00 108652 RK	R-7,200	Residential 7,200 sq. ft.	SFR-Basic
00 108653 RK	R-7,200	Residential 7,200 sq. ft.	SFR-Basic
00 109577 RK	R-7,200	Residential 7,200 sq. ft.	SFR-Basic
00 108658 RK	R-7,200	Residential 7,200 sq. ft.	SFR-Basic
00 108655 RK	R-7,200	Residential 7,200 sq. ft.	SFR-Basic
00 109580 RK	R-7,200	Residential 7,200 sq. ft.	SFR-Basic
00 109576 RK	R-7,200	Residential 7,200 sq. ft.	SFR-Basic
00 109578 RK	R-7,200	Residential 7,200 sq. ft.	SFR-Basic
00 109579 RK	R-7,200	Residential 7,200 sq. ft.	SFR-Basic
00 110474 RK	R-7,200	Residential 7,200 sq. ft.	SFR-Basic
00 110477 RK	R-7,200	Residential 7,200 sq. ft.	SFR-Basic
00 110470 RK	R-7,200	Residential 7,200 sq. ft.	SFR-Basic
00 110478 RK	R-7,200	Residential 7,200 sq. ft.	SFR-Basic
00 105585 RK	R-7,200	Residential 7,200 sq. ft.	SFR-Basic
00 105586 RK	R-7,200	Residential 7,200 sq. ft.	SFR-Basic
00 105587 RK	R-7,200	Residential 7,200 sq. ft.	SFR-Basic
00 105588 RK	R-7,200	Residential 7,200 sq. ft.	SFR-Basic

Accessory Dwelling Units

Index # - File Name: 1.0022 - Single Family Dwellings Data\_Snohomish County.pdf

00 105720 RK	R-7,200	Residential 7,200 sq. ft.	SFR-Basic
00 109582 RK	R-7,200	Residential 7,200 sq. ft.	SFR-Basic
00 102858 RK	R-9,600	Residential 9,600 sq. ft.	Single Family Res-Combo
00 102859 RK	R-9,600	Residential 9,600 sq. ft.	Single Family Res-Combo
00 108750 RK	R-9,600	Residential 9,600 sq. ft.	Single Family Res-Combo
00 104498 RK	RD	Rural Diversification	Single Family Res-Combo
00 106796 RK	PRD-7,200	Residential 7,200 sq. ft.	SFR-Basic
00 103986 RK	PRD-7,200	Residential 7,200 sq. ft.	SFR-Basic
00 106795 RK	PRD-7,200	Residential 7,200 sq. ft.	SFR-Basic
00 103991 RK	PRD-7,200	Residential 7,200 sq. ft.	SFR-Basic
00 103987 RK	PRD-7,200	Residential 7,200 sq. ft.	SFR-Basic
00 103988 RK	PRD-7,200	Residential 7,200 sq. ft.	SFR-Basic
00 104884 RK	PRD-7,200	Residential 7,200 sq. ft.	SFR-Basic
00 104883 RK	PRD-7,200	Residential 7,200 sq. ft.	SFR-Basic
00 103989 RK	PRD-7,200	Residential 7,200 sq. ft.	SFR-Basic
00 103990 RK	PRD-7,200	Residential 7,200 sq. ft.	SFR-Basic
00 107779 RK	R-7,200	Residential 7,200 sq. ft.	SFR-Basic
00 107777 RK	R-7,200	Residential 7,200 sq. ft.	SFR-Basic
00 107782 RK	R-7,200	Residential 7,200 sq. ft.	SFR-Basic
00 105590 RK	R-7,200	Residential 7,200 sq. ft.	SFR-Basic
00 105591 RK	R-7,200	Residential 7,200 sq. ft.	SFR-Basic
00 105592 RK	R-7,200	Residential 7,200 sq. ft.	SFR-Basic
00 103160 RK	R-5	Rural-5 Acre	Single Family Res-Combo
00 103204 MH	R-5	Rural-5 Acre	Double Wide
00 103253 MH	R-5	Rural-5 Acre	Double Wide
00 103288 MH	RRT-10	Rural Resource Transition-10	Double Wide
00 103625 RK	R-5	Rural-5 Acre	Single Family Res-Combo
99 115687 RK	PRD SA-1	Suburban Agriculture-1 Acre Duplex-Combo	
99 115686 RK	PRD SA-1	Suburban Agriculture-1 Acre Duplex-Combo	
00 103684 RK	PRD-LDMR	Low Density Multiple Reside	Single Family Res-Combo
00 104130 RK	PRD-LDMR	Low Density Multiple Reside	SFR-Basic
00 108341 RK	PRD-LDMR	Low Density Multiple Reside	SFR-Basic
00 104128 RK	PRD-LDMR	Low Density Multiple Reside	Single Family Res-Combo
00 103780 RK	PRD-LDMR	Low Density Multiple Reside	Single Family Res-Combo
00 105734 RK	PRD-LDMR	Low Density Multiple Reside	SFR-Basic
00 104129 RK	PRD-LDMR	Low Density Multiple Reside	SFR-Basic
00 104131 RK	PRD-LDMR	Low Density Multiple Reside	SFR-Basic
00 105735 RK	PRD-LDMR	Low Density Multiple Reside	SFR-Basic
00 102434 RK	PRD-LDMR	Low Density Multiple Reside	Single Family Res-Combo
00 104059 RK	PRD-LDMR	Low Density Multiple Reside	Single Family Res-Combo
00 103781 RK	PRD-LDMR	Low Density Multiple Reside	Single Family Res-Combo
00 104061 RK	PRD-LDMR	Low Density Multiple Reside	Single Family Res-Combo
00 105758 RK	PRD-LDMR	Low Density Multiple Reside	SFR-Basic
00 103706 RK	PRD-LDMR	Low Density Multiple Reside	SFR-Basic
00 107524 RK	PRD-LDMR	Low Density Multiple Reside	SFR-Basic
00 103707 RK	PRD-LDMR	Low Density Multiple Reside	SFR-Basic
00 103708 RK	PRD-LDMR	Low Density Multiple Reside	SFR-Basic

Accessory Dwelling Units

Index # - File Name: 1.0022 - Single Family Dwellings Data\_Snohomish County.pdf

00 107835 RK	PRD-LDMR	Low Density Multiple Reside SFR-Basic
00 106689 RK	PRD-LDMR	Low Density Multiple Reside SFR-Basic
00 104377 RK	PRD-LDMR	Low Density Multiple Reside Single Family Res-Combo
00 104760 RK	PRD-LDMR	Low Density Multiple Reside SFR-Basic
00 107525 RK	PRD-LDMR	Low Density Multiple Reside SFR-Basic
00 104075 RK	PRD-LDMR	Low Density Multiple Reside SFR-Basic
00 108426 RK	PRD-LDMR	Low Density Multiple Reside SFR-Basic
00 104078 RK	PRD-LDMR	Low Density Multiple Reside SFR-Basic
00 104076 RK	PRD-LDMR	Low Density Multiple Reside SFR-Basic
00 104762 RK	PRD-LDMR	Low Density Multiple Reside SFR-Basic
00 104503 RK	PRD-LDMR	Low Density Multiple Reside SFR-Basic
00 104504 RK	PRD-LDMR	Low Density Multiple Reside SFR-Basic
00 104374 RK	PRD-LDMR	Low Density Multiple Reside SFR-Basic
00 104375 RK	PRD-LDMR	Low Density Multiple Reside SFR-Basic
00 104505 RK	PRD-LDMR	Low Density Multiple Reside SFR-Basic
00 108428 RK	PRD-LDMR	Low Density Multiple Reside SFR-Basic
99 115685 RK	PRD SA-1	Suburban Agriculture-1 Acre Duplex-Combo
99 115683 RK	PRD SA-1	Suburban Agriculture-1 Acre Duplex-Combo
99 115682 RK	PRD SA-1	Suburban Agriculture-1 Acre Duplex-Combo
00 103393 RK	R-9,600	Residential 9,600 sq. ft. SFR-Basic
99 115657 RK	R-9,600	Residential 9,600 sq. ft. Single Family Res-Combo
00 106069 RK	R-9,600	Residential 9,600 sq. ft. Single Family Res-Combo
00 103497 RK	R-9,600	Residential 9,600 sq. ft. Single Family Res-Combo
00 108102 RK	R-9,600	Residential 9,600 sq. ft. SFR-Basic
00 108715 RK	R-9,600	Residential 9,600 sq. ft. SFR-Basic
00 103194 RK	R-9,600	Residential 9,600 sq. ft. Single Family Res-Combo
98 109061 RK	R-9,600	Residential 9,600 sq. ft. Single Family Res-Combo
00 103704 RK	PRD-LDMR	Low Density Multiple Reside SFR-Basic
00 103705 RK	PRD-LDMR	Low Density Multiple Reside SFR-Basic
00 105759 RK	PRD-LDMR	Low Density Multiple Reside SFR-Basic
00 103786 RK	PRD-LDMR	Low Density Multiple Reside SFR-Basic
00 103782 RK	PRD-LDMR	Low Density Multiple Reside Single Family Res-Combo
00 103787 RK	PRD-LDMR	Low Density Multiple Reside SFR-Basic
00 103788 RK	PRD-LDMR	Low Density Multiple Reside SFR-Basic
00 104062 RK	PRD-LDMR	Low Density Multiple Reside Single Family Res-Combo
00 103790 RK	PRD-LDMR	Low Density Multiple Reside SFR-Basic
00 104888 RK	PRD-LDMR	Low Density Multiple Reside SFR-Basic
00 104079 RK	PRD-LDMR	Low Density Multiple Reside SFR-Basic
00 104761 RK	PRD-LDMR	Low Density Multiple Reside SFR-Basic
00 107959 RK	PRD-LDMR	Low Density Multiple Reside SFR-Basic
00 104506 RK	PRD-LDMR	Low Density Multiple Reside SFR-Basic
00 103784 RK	PRD-LDMR	Low Density Multiple Reside Single Family Res-Combo
00 103835 RK	R-5	Rural-5 Acre SFR-Basic
00 104690 RK	PRD-LDMR	Low Density Multiple Reside SFR-Basic
00 105287 RK	PRD-LDMR	Low Density Multiple Reside Single Family Res-Combo
00 105290 RK	PRD-LDMR	Low Density Multiple Reside SFR-Basic
00 104563 RK	PRD-LDMR	Low Density Multiple Reside SFR-Basic

Accessory Dwelling Units

Index # - File Name: 1.0022 - Single Family Dwellings Data\_Snohomish County.pdf

00 104566 RK	PRD-LDMR	Low Density Multiple Reside	SFR-Basic
00 104567 RK	PRD-LDMR	Low Density Multiple Reside	SFR-Basic
00 104568 RK	PRD-LDMR	Low Density Multiple Reside	SFR-Basic
00 104564 RK	PRD-LDMR	Low Density Multiple Reside	SFR-Basic
00 100663 RK	PRD-LDMR	Low Density Multiple Reside	Single Family Res-Combo
00 104565 RK	PRD-LDMR	Low Density Multiple Reside	SFR-Basic
00 104562 RK	PRD-LDMR	Low Density Multiple Reside	SFR-Basic
00 100664 RK	PRD-LDMR	Low Density Multiple Reside	Single Family Res-Combo
00 100661 RK	PRD-LDMR	Low Density Multiple Reside	Single Family Res-Combo
00 100665 RK	PRD-LDMR	Low Density Multiple Reside	Single Family Res-Combo
00 103967 RK	PRD-LDMR	Low Density Multiple Reside	SFR-Basic
00 100662 RK	PRD-LDMR	Low Density Multiple Reside	Single Family Res-Combo
00 104939 RK	R-5	Rural-5 Acre	SFR-Basic
00 104065 RK	R-5	Rural-5 Acre	Single Family Res-Combo
00 104077 RK	R-5	Rural-5 Acre	Single Family Res-Combo
00 104114 RK	R-5	Rural-5 Acre	Single Family Res-Combo
00 104120 RK	R-5	Rural-5 Acre	Single Family Res-Combo
00 104156 MH	R-5	Rural-5 Acre	Single Wide
00 104288 RK	R-7,200	Residential 7,200 sq. ft.	SFR-Basic
00 104195 MH	CITY	City	MH Park-Double Wide
00 101644 RK	PRD-7,200	Residential 7,200 sq. ft.	Single Family Res-Combo
00 101646 RK	PRD-7,200	Residential 7,200 sq. ft.	Single Family Res-Combo
00 101647 RK	PRD-7,200	Residential 7,200 sq. ft.	Single Family Res-Combo
00 104185 RK	PRD-7,200	Residential 7,200 sq. ft.	SFR-Basic
00 104178 RK	PRD-7,200	Residential 7,200 sq. ft.	SFR-Basic
00 101645 RK	PRD-7,200	Residential 7,200 sq. ft.	Single Family Res-Combo
00 104184 RK	PRD-7,200	Residential 7,200 sq. ft.	SFR-Basic
00 104183 RK	PRD-7,200	Residential 7,200 sq. ft.	SFR-Basic
00 104177 RK	PRD-7,200	Residential 7,200 sq. ft.	SFR-Basic
00 104179 RK	PRD-7,200	Residential 7,200 sq. ft.	SFR-Basic
00 104182 RK	PRD-7,200	Residential 7,200 sq. ft.	SFR-Basic
00 104176 RK	PRD-7,200	Residential 7,200 sq. ft.	SFR-Basic
00 104189 RK	PRD-7,200	Residential 7,200 sq. ft.	SFR-Basic
00 104187 RK	PRD-7,200	Residential 7,200 sq. ft.	SFR-Basic
00 104414 RK	R-5	Rural-5 Acre	SFR-Basic
00 104415 RK	R-5	Rural-5 Acre	SFR-Basic
00 104416 RK	R-5	Rural-5 Acre	SFR-Basic
00 104353 MH	RD	Rural Diversification	Triple Wide
00 104413 RK	R-5	Rural-5 Acre	SFR-Basic
00 109283 RK	R-5	Rural-5 Acre	SFR-Basic
00 105650 RK	R-5	Rural-5 Acre	SFR-Basic
00 105044 MH	R-5	Rural-5 Acre	Double Wide
00 102387 RK	R-7,200	Residential 7,200 sq. ft.	SFR-Basic
00 106310 RK	R-7,200	Residential 7,200 sq. ft.	Single Family Res-Combo
00 101611 RK	R-7,200	Residential 7,200 sq. ft.	Single Family Res-Combo
99 115831 RK	R-5	Rural-5 Acre	Single Family Res-Combo
99 116135 RK	R-7,200	Residential 7,200 sq. ft.	SFR-Basic

Accessory Dwelling Units

Index # - File Name: 1.0022 - Single Family Dwellings Data\_Snohomish County.pdf

99 116134 RK	R-7,200	Residential 7,200 sq. ft.	SFR-Basic
99 116133 RK	R-7,200	Residential 7,200 sq. ft.	SFR-Basic
00 108354 RK	CITY	City	SFR-Basic
00 108360 RK	CITY	City	SFR-Basic
00 108356 RK	CITY	City	SFR-Basic
00 103394 RK	CITY	City	SFR-Basic
00 108355 RK	CITY	City	SFR-Basic
00 100584 RK	R-7,200	Residential 7,200 sq. ft.	SFR-Basic
00 105976 RK	CITY	City	SFR-Basic
99 116167 RK	CITY	City	Single Family Res-Combo
00 103391 RK	CITY	City	Single Family Res-Combo
99 116527 MH	R-5	Rural-5 Acre	Double Wide
00 104796 RK	R-7,200	Residential 7,200 sq. ft.	SFR-Basic
00 104793 RK	R-7,200	Residential 7,200 sq. ft.	SFR-Basic
00 104790 RK	R-7,200	Residential 7,200 sq. ft.	SFR-Basic
00 104847 RK	R-7,200	Residential 7,200 sq. ft.	SFR-Basic
00 106833 RK	R-7,200	Residential 7,200 sq. ft.	SFR-Basic
00 104849 RK	R-7,200	Residential 7,200 sq. ft.	SFR-Basic
00 104850 RK	R-7,200	Residential 7,200 sq. ft.	SFR-Basic
00 104853 RK	R-7,200	Residential 7,200 sq. ft.	SFR-Basic
00 104852 RK	R-7,200	Residential 7,200 sq. ft.	SFR-Basic
00 106832 RK	R-7,200	Residential 7,200 sq. ft.	SFR-Basic
00 104795 RK	R-7,200	Residential 7,200 sq. ft.	SFR-Basic
00 106834 RK	R-7,200	Residential 7,200 sq. ft.	SFR-Basic
00 104729 RK	R-7,200	Residential 7,200 sq. ft.	SFR-Basic
00 106830 RK	R-7,200	Residential 7,200 sq. ft.	SFR-Basic
00 104733 RK	R-7,200	Residential 7,200 sq. ft.	SFR-Basic
00 102457 RK	R-7,200	Residential 7,200 sq. ft.	SFR-Basic
99 116035 RK	R-7,200	Residential 7,200 sq. ft.	SFR-Basic
00 102186 RK	R-7,200	Residential 7,200 sq. ft.	SFR-Basic
98 110283 RK	R-7,200	Residential 7,200 sq. ft.	Single Family Res-Combo
00 100587 RK	R-7,200	Residential 7,200 sq. ft.	Single Family Res-Combo
98 109714 RK	R-7,200	Residential 7,200 sq. ft.	Single Family Res-Combo
00 102593 RK	R-7,200	Residential 7,200 sq. ft.	SFR-Basic
00 104730 RK	R-7,200	Residential 7,200 sq. ft.	SFR-Basic
00 104734 RK	R-7,200	Residential 7,200 sq. ft.	SFR-Basic
00 104731 RK	R-7,200	Residential 7,200 sq. ft.	SFR-Basic
00 101527 RK	R-7,200	Residential 7,200 sq. ft.	SFR-Basic
99 116034 RK	R-7,200	Residential 7,200 sq. ft.	SFR-Basic
00 100581 RK	R-7,200	Residential 7,200 sq. ft.	Single Family Res-Combo
00 101164 RK	R-7,200	Residential 7,200 sq. ft.	SFR-Basic
00 102456 RK	R-7,200	Residential 7,200 sq. ft.	SFR-Basic
00 102451 RK	R-7,200	Residential 7,200 sq. ft.	SFR-Basic
00 106836 RK	R-7,200	Residential 7,200 sq. ft.	SFR-Basic
00 107052 RK	R-7,200	Residential 7,200 sq. ft.	SFR-Basic
00 100586 RK	R-7,200	Residential 7,200 sq. ft.	SFR-Basic
00 102184 RK	R-7,200	Residential 7,200 sq. ft.	SFR-Basic

Accessory Dwelling Units

Index # - File Name: 1.0022 - Single Family Dwellings Data\_Snohomish County.pdf

00 100583 RK	R-7,200	Residential 7,200 sq. ft.	SFR-Basic
99 104295 RK	R-7,200	Residential 7,200 sq. ft.	Single Family Res-Combo
00 102185 RK	R-7,200	Residential 7,200 sq. ft.	SFR-Basic
99 116036 RK	R-7,200	Residential 7,200 sq. ft.	SFR-Basic
00 102588 RK	R-7,200	Residential 7,200 sq. ft.	SFR-Basic
00 104791 RK	R-7,200	Residential 7,200 sq. ft.	SFR-Basic
00 104797 RK	R-7,200	Residential 7,200 sq. ft.	SFR-Basic
00 104792 RK	R-7,200	Residential 7,200 sq. ft.	SFR-Basic
00 106643 RK	R-7,200	Residential 7,200 sq. ft.	SFR-Basic
00 104794 RK	R-7,200	Residential 7,200 sq. ft.	SFR-Basic
00 106831 RK	R-7,200	Residential 7,200 sq. ft.	SFR-Basic
00 104854 RK	R-7,200	Residential 7,200 sq. ft.	SFR-Basic
00 106835 RK	R-7,200	Residential 7,200 sq. ft.	SFR-Basic
00 106837 RK	R-7,200	Residential 7,200 sq. ft.	SFR-Basic
99 116033 RK	R-7,200	Residential 7,200 sq. ft.	SFR-Basic
00 101287 RK	R-7,200	Residential 7,200 sq. ft.	SFR-Basic
00 102183 RK	R-7,200	Residential 7,200 sq. ft.	SFR-Basic
00 100580 RK	R-7,200	Residential 7,200 sq. ft.	SFR-Basic
00 107053 RK	R-7,200	Residential 7,200 sq. ft.	SFR-Basic
00 105722 RK	R-7,200	Residential 7,200 sq. ft.	SFR-Basic
99 116067 RK	R-5	Rural-5 Acre	Single Family Res-Combo
00 101634 RK	CITY	City	SFR-Basic
00 101633 RK	CITY	City	SFR-Basic
00 101206 RK	CITY	City	SFR-Basic
00 101207 RK	CITY	City	SFR-Basic
00 100927 RK	CITY	City	Single Family Res-Combo
00 101208 RK	CITY	City	SFR-Basic
00 101209 RK	CITY	City	SFR-Basic
00 100858 RK	CITY	City	Single Family Res-Combo
00 101482 RK	CITY	City	SFR-Basic
00 101635 RK	CITY	City	SFR-Basic
00 101484 RK	CITY	City	SFR-Basic
00 101636 RK	CITY	City	SFR-Basic
00 101488 RK	CITY	City	SFR-Basic
00 101490 RK	CITY	City	SFR-Basic
00 101629 RK	CITY	City	SFR-Basic
00 101637 RK	CITY	City	SFR-Basic
00 101638 RK	CITY	City	SFR-Basic
00 101211 RK	CITY	City	SFR-Basic
00 101630 RK	CITY	City	SFR-Basic
00 100987 RK	CITY	City	Single Family Res-Combo
00 101631 RK	CITY	City	SFR-Basic
00 101365 RK	CITY	City	SFR-Basic
00 100650 RK	R-5	Rural-5 Acre	Single Family Res-Combo
00 102394 RK	R-8,400	Residential 8,400 sq. ft.	Single Family Res-Combo
00 102271 RK	R-8,400	Residential 8,400 sq. ft.	SFR-Basic
00 101549 RK	R-8,400	Residential 8,400 sq. ft.	SFR-Basic

Accessory Dwelling Units

Index # - File Name: 1.0022 - Single Family Dwellings Data\_Snohomish County.pdf

00 103275 RK	R-8,400	Residential 8,400 sq. ft.	SFR-Basic
00 103276 RK	R-8,400	Residential 8,400 sq. ft.	SFR-Basic
99 115916 RK	R-8,400	Residential 8,400 sq. ft.	Single Family Res-Combo
00 101016 RK	R-8,400	Residential 8,400 sq. ft.	Single Family Res-Combo
00 100491 RK	R-5	Rural-5 Acre	Single Family Res-Combo
00 104249 RK	R-5	Rural-5 Acre	SFR-Basic
00 105509 RK	R-8,400	Residential 8,400 sq. ft.	SFR-Basic
00 105512 RK	R-8,400	Residential 8,400 sq. ft.	SFR-Basic
00 103354 RK	R-8,400	Residential 8,400 sq. ft.	Single Family Res-Combo
00 100814 RK	R-8,400	Residential 8,400 sq. ft.	SFR-Basic
00 104285 RK	PRD-8,400	Residential 8,400 sq. ft.	Single Family Res-Combo
00 104808 RK	PRD-8,400	Residential 8,400 sq. ft.	SFR-Basic
00 101191 RK	PRD-8,400	Residential 8,400 sq. ft.	Single Family Res-Combo
00 102151 RK	PRD-8,400	Residential 8,400 sq. ft.	Single Family Res-Combo
00 104282 RK	PRD-8,400	Residential 8,400 sq. ft.	SFR-Basic
00 104806 RK	PRD-8,400	Residential 8,400 sq. ft.	Single Family Res-Combo
00 105731 RK	PRD-8,400	Residential 8,400 sq. ft.	Single Family Res-Combo
00 104809 RK	PRD-8,400	Residential 8,400 sq. ft.	SFR-Basic
00 102580 RK	PRD-8,400	Residential 8,400 sq. ft.	SFR-Basic
00 104283 RK	PRD-8,400	Residential 8,400 sq. ft.	SFR-Basic
00 104873 RK	PRD-8,400	Residential 8,400 sq. ft.	SFR-Basic
00 107520 RK	PRD-8,400	Residential 8,400 sq. ft.	SFR-Basic
00 104757 RK	PRD-8,400	Residential 8,400 sq. ft.	SFR-Basic
00 102529 RK	PRD-8,400	Residential 8,400 sq. ft.	SFR-Basic
00 102205 RK	PRD-8,400	Residential 8,400 sq. ft.	SFR-Basic
00 102206 RK	PRD-8,400	Residential 8,400 sq. ft.	SFR-Basic
00 101195 RK	PRD-8,400	Residential 8,400 sq. ft.	SFR-Basic
00 103309 RK	PRD-8,400	Residential 8,400 sq. ft.	SFR-Basic
00 108632 RK	PRD-8,400	Residential 8,400 sq. ft.	SFR-Basic
00 109984 RK	PRD-8,400	Residential 8,400 sq. ft.	SFR-Basic
00 101198 RK	PRD-8,400	Residential 8,400 sq. ft.	SFR-Basic
00 101196 RK	PRD-8,400	Residential 8,400 sq. ft.	SFR-Basic
00 104284 RK	PRD-8,400	Residential 8,400 sq. ft.	Single Family Res-Combo
00 106350 RK	PRD-8,400	Residential 8,400 sq. ft.	SFR-Basic
00 104281 RK	PRD-8,400	Residential 8,400 sq. ft.	SFR-Basic
00 105732 RK	PRD-8,400	Residential 8,400 sq. ft.	Single Family Res-Combo
00 106423 RK	PRD-8,400	Residential 8,400 sq. ft.	SFR-Basic
00 106424 RK	PRD-8,400	Residential 8,400 sq. ft.	SFR-Basic
00 107522 RK	PRD-8,400	Residential 8,400 sq. ft.	SFR-Basic
00 104756 RK	PRD-8,400	Residential 8,400 sq. ft.	SFR-Basic
00 103494 RK	PRD-8,400	Residential 8,400 sq. ft.	SFR-Basic
00 107439 RK	PRD-8,400	Residential 8,400 sq. ft.	SFR-Basic
00 102969 RK	PRD-8,400	Residential 8,400 sq. ft.	SFR-Basic
00 105757 RK	PRD-8,400	Residential 8,400 sq. ft.	SFR-Basic
00 102531 RK	PRD-8,400	Residential 8,400 sq. ft.	SFR-Basic
00 104502 RK	PRD-8,400	Residential 8,400 sq. ft.	SFR-Basic
00 102532 RK	PRD-8,400	Residential 8,400 sq. ft.	SFR-Basic



Accessory Dwelling Units

Index # - File Name: 1.0022 - Single Family Dwellings Data\_Snohomish County.pdf

00 106935 RK	PRD-8,400	Residential 8,400 sq. ft.	SFR-Basic
00 104072 RK	R-8,400	Residential 8,400 sq. ft.	SFR-Basic
00 107309 RK	R-8,400	Residential 8,400 sq. ft.	SFR-Basic
99 115917 RK	R-8,400	Residential 8,400 sq. ft.	Single Family Res-Combo
00 101419 RK	R-7,200	Residential 7,200 sq. ft.	SFR-Basic
00 101422 RK	R-7,200	Residential 7,200 sq. ft.	SFR-Basic
00 101424 RK	R-7,200	Residential 7,200 sq. ft.	Single Family Res-Combo
00 103023 RK	R-7,200	Residential 7,200 sq. ft.	Single Family Res-Combo
00 101551 RK	R-8,400	Residential 8,400 sq. ft.	SFR-Basic
00 107567 RK	R-5	Rural-5 Acre	Single Family Res-Combo
00 101663 RK	PRD-7,200	Residential 7,200 sq. ft.	SFR-Basic
00 101668 RK	PRD-7,200	Residential 7,200 sq. ft.	SFR-Basic
00 101662 RK	PRD-7,200	Residential 7,200 sq. ft.	SFR-Basic
00 101667 RK	PRD-7,200	Residential 7,200 sq. ft.	SFR-Basic
00 101666 RK	PRD-7,200	Residential 7,200 sq. ft.	SFR-Basic
00 101665 RK	PRD-7,200	Residential 7,200 sq. ft.	SFR-Basic
00 105632 RK	PRD-7,200	Residential 7,200 sq. ft.	SFR-Basic
00 105634 RK	PRD-7,200	Residential 7,200 sq. ft.	SFR-Basic
00 102545 RK	PRD-7,200	Residential 7,200 sq. ft.	SFR-Basic
00 102541 RK	PRD-7,200	Residential 7,200 sq. ft.	SFR-Basic
00 102542 RK	PRD-7,200	Residential 7,200 sq. ft.	SFR-Basic
00 102544 RK	PRD-7,200	Residential 7,200 sq. ft.	SFR-Basic
00 104439 RK	PRD-7,200	Residential 7,200 sq. ft.	SFR-Basic
00 102954 RK	PRD-7,200	Residential 7,200 sq. ft.	SFR-Basic
00 102953 RK	PRD-7,200	Residential 7,200 sq. ft.	SFR-Basic
00 103566 RK	PRD-7,200	Residential 7,200 sq. ft.	SFR-Basic
00 104438 RK	PRD-7,200	Residential 7,200 sq. ft.	SFR-Basic
00 104437 RK	PRD-7,200	Residential 7,200 sq. ft.	SFR-Basic
00 104441 RK	PRD-7,200	Residential 7,200 sq. ft.	SFR-Basic
00 104440 RK	PRD-7,200	Residential 7,200 sq. ft.	SFR-Basic
00 103570 RK	PRD-7,200	Residential 7,200 sq. ft.	SFR-Basic
00 103569 RK	PRD-7,200	Residential 7,200 sq. ft.	SFR-Basic
00 103565 RK	PRD-7,200	Residential 7,200 sq. ft.	SFR-Basic
00 103568 RK	PRD-7,200	Residential 7,200 sq. ft.	SFR-Basic
00 103567 RK	PRD-7,200	Residential 7,200 sq. ft.	SFR-Basic
00 103460 RK	PRD-7,200	Residential 7,200 sq. ft.	SFR-Basic
00 103459 RK	PRD-7,200	Residential 7,200 sq. ft.	SFR-Basic
00 107364 RK	PRD-7,200	Residential 7,200 sq. ft.	SFR-Basic
00 107365 RK	PRD-7,200	Residential 7,200 sq. ft.	SFR-Basic
00 107366 RK	PRD-7,200	Residential 7,200 sq. ft.	SFR-Basic
00 106621 RK	PRD-7,200	Residential 7,200 sq. ft.	SFR-Basic
00 106878 RK	PRD-7,200	Residential 7,200 sq. ft.	SFR-Basic
00 106617 RK	PRD-7,200	Residential 7,200 sq. ft.	SFR-Basic
00 105937 RK	PRD-7,200	Residential 7,200 sq. ft.	SFR-Basic
00 102540 RK	PRD-7,200	Residential 7,200 sq. ft.	SFR-Basic
00 101671 RK	PRD-7,200	Residential 7,200 sq. ft.	SFR-Basic
00 101670 RK	PRD-7,200	Residential 7,200 sq. ft.	SFR-Basic

Accessory Dwelling Units

Index # - File Name: 1.0022 - Single Family Dwellings Data\_Snohomish County.pdf

00 101669 RK	PRD-7,200	Residential 7,200 sq. ft.	SFR-Basic
00 101664 RK	PRD-7,200	Residential 7,200 sq. ft.	SFR-Basic
00 105936 RK	PRD-7,200	Residential 7,200 sq. ft.	SFR-Basic
00 101039 MH	MHP	Mobile Home Park	MH Park-Double Wide
00 102762 RK	R-5	Rural-5 Acre	Single Family Res-Combo
00 102769 RK	R-5	Rural-5 Acre	Single Family Res-Combo
99 109557 RK	R-5	Rural-5 Acre	Single Family Res-Combo
00 102866 RK	R-5	Rural-5 Acre	Single Family Res-Combo
00 101261 RK	R-5	Rural-5 Acre	Single Family Res-Combo
00 102399 RK	CITY	City	SFR-Basic
00 102437 RK	CITY	City	SFR-Basic
00 103733 RK	CITY	City	SFR-Basic
00 104547 RK	CITY	City	SFR-Basic
00 103734 RK	CITY	City	SFR-Basic
00 105005 RK	CITY	City	SFR-Basic
00 105006 RK	CITY	City	SFR-Basic
00 103456 RK	CITY	City	Single Family Res-Combo
00 104552 RK	CITY	City	SFR-Basic
00 105007 RK	CITY	City	SFR-Basic
00 105008 RK	CITY	City	SFR-Basic
00 105009 RK	CITY	City	SFR-Basic
00 105010 RK	CITY	City	SFR-Basic
00 103736 RK	CITY	City	SFR-Basic
00 103458 RK	CITY	City	Single Family Res-Combo
00 103735 RK	CITY	City	SFR-Basic
00 101339 RK	CITY	City	Single Family Res-Combo
00 102401 RK	CITY	City	SFR-Basic
00 106934 RK	PRD-8,400	Residential 8,400 sq. ft.	SFR-Basic
00 101928 RK	PRD-8,400	Residential 8,400 sq. ft.	SFR-Basic
00 102524 RK	PRD-8,400	Residential 8,400 sq. ft.	SFR-Basic
00 101926 RK	PRD-8,400	Residential 8,400 sq. ft.	SFR-Basic
00 101927 RK	PRD-8,400	Residential 8,400 sq. ft.	SFR-Basic
00 102846 RK	PRD-8,400	Residential 8,400 sq. ft.	SFR-Basic
00 102202 RK	PRD-8,400	Residential 8,400 sq. ft.	SFR-Basic
00 102526 RK	PRD-8,400	Residential 8,400 sq. ft.	SFR-Basic
00 102522 RK	PRD-8,400	Residential 8,400 sq. ft.	SFR-Basic
00 103305 RK	PRD-8,400	Residential 8,400 sq. ft.	SFR-Basic
00 102527 RK	PRD-8,400	Residential 8,400 sq. ft.	SFR-Basic
00 102971 RK	PRD-8,400	Residential 8,400 sq. ft.	SFR-Basic
00 102972 RK	PRD-8,400	Residential 8,400 sq. ft.	SFR-Basic
00 108429 RK	PRD-8,400	Residential 8,400 sq. ft.	SFR-Basic
00 103306 RK	PRD-8,400	Residential 8,400 sq. ft.	SFR-Basic
00 103307 RK	PRD-8,400	Residential 8,400 sq. ft.	SFR-Basic
00 107519 RK	PRD-8,400	Residential 8,400 sq. ft.	Single Family Res-Combo
00 106921 RK	PRD-8,400	Residential 8,400 sq. ft.	Single Family Res-Combo
00 101839 RK	A-10	Agriculture-10 Acre	Single Family Res-Combo
00 101937 RK	PRD-9,600	Residential 9,600 sq. ft.	Single Family Res-Combo

Accessory Dwelling Units

Index # - File Name: 1.0022 - Single Family Dwellings Data\_Snohomish County.pdf

00 103116 RK	PRD-9,600	Residential 9,600 sq. ft.	SFR-Basic
00 106257 RK	PRD-9,600	Residential 9,600 sq. ft.	SFR-Basic
00 103119 RK	PRD-9,600	Residential 9,600 sq. ft.	SFR-Basic
00 103117 RK	PRD-9,600	Residential 9,600 sq. ft.	SFR-Basic
00 103120 RK	PRD-9,600	Residential 9,600 sq. ft.	SFR-Basic
00 106254 RK	PRD-9,600	Residential 9,600 sq. ft.	SFR-Basic
00 106255 RK	PRD-9,600	Residential 9,600 sq. ft.	SFR-Basic
00 106256 RK	PRD-9,600	Residential 9,600 sq. ft.	SFR-Basic
00 103740 RK	PRD-9,600	Residential 9,600 sq. ft.	SFR-Basic
00 103742 RK	PRD-9,600	Residential 9,600 sq. ft.	SFR-Basic
00 103743 RK	PRD-9,600	Residential 9,600 sq. ft.	SFR-Basic
00 106253 RK	PRD-9,600	Residential 9,600 sq. ft.	SFR-Basic
00 103741 RK	PRD-9,600	Residential 9,600 sq. ft.	SFR-Basic
00 103744 RK	PRD-9,600	Residential 9,600 sq. ft.	SFR-Basic
00 103121 RK	PRD-9,600	Residential 9,600 sq. ft.	SFR-Basic
00 103118 RK	PRD-9,600	Residential 9,600 sq. ft.	SFR-Basic
00 101949 RK	R-5	Rural-5 Acre	Single Family Res-Combo
00 101729 RK	R-9,600	Residential 9,600 sq. ft.	Single Family Res-Combo
00 101728 RK	R-9,600	Residential 9,600 sq. ft.	Single Family Res-Combo
00 101860 RK	R-9,600	Residential 9,600 sq. ft.	Single Family Res-Combo
00 101730 RK	R-9,600	Residential 9,600 sq. ft.	Single Family Res-Combo
00 102976 RK	R-9,600	Residential 9,600 sq. ft.	Single Family Res-Combo
00 101858 RK	R-9,600	Residential 9,600 sq. ft.	Single Family Res-Combo
00 101859 RK	R-9,600	Residential 9,600 sq. ft.	Single Family Res-Combo
00 103162 RK	R-9,600	Residential 9,600 sq. ft.	SFR-Basic
00 103168 RK	R-9,600	Residential 9,600 sq. ft.	SFR-Basic
00 103506 RK	R-9,600	Residential 9,600 sq. ft.	Single Family Res-Combo
00 103507 RK	R-9,600	Residential 9,600 sq. ft.	Single Family Res-Combo
00 102213 RK	R-9,600	Residential 9,600 sq. ft.	SFR-Basic
00 105884 RK	R-5	Rural-5 Acre	Single Family Res-Combo
00 110200 RK	CITY	City	SFR-Basic
00 110201 RK	CITY	City	SFR-Basic
00 107540 RK	CITY	City	SFR-Basic
00 107173 RK	CITY	City	SFR-Basic
00 107175 RK	CITY	City	SFR-Basic
00 107178 RK	CITY	City	SFR-Basic
00 107177 RK	CITY	City	SFR-Basic
00 107174 RK	CITY	City	SFR-Basic
00 104918 RK	CITY	City	SFR-Basic
00 104913 RK	CITY	City	SFR-Basic
00 104916 RK	CITY	City	SFR-Basic
00 110196 RK	CITY	City	SFR-Basic
00 110197 RK	CITY	City	SFR-Basic
00 110199 RK	CITY	City	SFR-Basic
00 107170 RK	CITY	City	SFR-Basic
00 107172 RK	CITY	City	SFR-Basic
00 107171 RK	CITY	City	SFR-Basic

Accessory Dwelling Units

Index # - File Name: 1.0022 - Single Family Dwellings Data\_Snohomish County.pdf

00 104919 RK	CITY	City	SFR-Basic
99 112822 RK	CITY	City	Single Family Res-Combo
00 104914 RK	CITY	City	SFR-Basic
00 104917 RK	CITY	City	SFR-Basic
00 105058 RK	LDMR	Low Density Multiple Reside	Single Family Res-Combo
00 105957 RK	PRD-9,600	Residential 9,600 sq. ft.	SFR-Basic
00 106101 RK	PRD-9,600	Residential 9,600 sq. ft.	SFR-Basic
00 105029 RK	PRD-9,600	Residential 9,600 sq. ft.	SFR-Basic
00 109265 RK	PRD-9,600	Residential 9,600 sq. ft.	SFR-Basic
00 107249 RK	PRD-9,600	Residential 9,600 sq. ft.	SFR-Basic
00 105030 RK	PRD-9,600	Residential 9,600 sq. ft.	Single Family Res-Combo
00 107194 RK	PRD-9,600	Residential 9,600 sq. ft.	SFR-Basic
00 104973 RK	PRD-9,600	Residential 9,600 sq. ft.	SFR-Basic
00 105031 RK	PRD-9,600	Residential 9,600 sq. ft.	SFR-Basic
00 105032 RK	PRD-9,600	Residential 9,600 sq. ft.	SFR-Basic
00 107255 RK	PRD-9,600	Residential 9,600 sq. ft.	SFR-Basic
00 106105 RK	PRD-9,600	Residential 9,600 sq. ft.	SFR-Basic
00 107251 RK	PRD-9,600	Residential 9,600 sq. ft.	SFR-Basic
00 107193 RK	PRD-9,600	Residential 9,600 sq. ft.	SFR-Basic
00 109226 RK	PRD-9,600	Residential 9,600 sq. ft.	Single Family Res-Combo
00 106103 RK	PRD-9,600	Residential 9,600 sq. ft.	SFR-Basic
00 104971 RK	PRD-9,600	Residential 9,600 sq. ft.	SFR-Basic
00 109307 RK	PRD-9,600	Residential 9,600 sq. ft.	Single Family Res-Combo
00 107197 RK	PRD-9,600	Residential 9,600 sq. ft.	SFR-Basic
00 105091 RK	CITY	City	Duplex-Combo
00 106942 RK	PRD-9,600	Residential 9,600 sq. ft.	SFR-Basic
00 106268 RK	PRD-9,600	Residential 9,600 sq. ft.	Single Family Res-Combo
00 107200 RK	PRD-9,600	Residential 9,600 sq. ft.	SFR-Basic
00 104977 RK	PRD-9,600	Residential 9,600 sq. ft.	SFR-Basic
00 107201 RK	PRD-9,600	Residential 9,600 sq. ft.	SFR-Basic
00 106941 RK	PRD-9,600	Residential 9,600 sq. ft.	SFR-Basic
00 107750 RK	PRD-9,600	Residential 9,600 sq. ft.	SFR-Basic
00 107254 RK	PRD-9,600	Residential 9,600 sq. ft.	SFR-Basic
00 107252 RK	PRD-9,600	Residential 9,600 sq. ft.	SFR-Basic
00 107202 RK	PRD-9,600	Residential 9,600 sq. ft.	SFR-Basic
00 108887 RK	PRD-9,600	Residential 9,600 sq. ft.	Single Family Res-Combo
00 107749 RK	PRD-9,600	Residential 9,600 sq. ft.	SFR-Basic
00 107748 RK	PRD-9,600	Residential 9,600 sq. ft.	SFR-Basic
00 106943 RK	PRD-9,600	Residential 9,600 sq. ft.	SFR-Basic
00 108303 RK	PRD-9,600	Residential 9,600 sq. ft.	SFR-Basic
00 107751 RK	PRD-9,600	Residential 9,600 sq. ft.	SFR-Basic
00 104976 RK	PRD-9,600	Residential 9,600 sq. ft.	SFR-Basic
00 105958 RK	PRD-9,600	Residential 9,600 sq. ft.	SFR-Basic
00 106012 RK	PRD-9,600	Residential 9,600 sq. ft.	SFR-Basic
00 106940 RK	PRD-9,600	Residential 9,600 sq. ft.	SFR-Basic
00 109306 RK	PRD-9,600	Residential 9,600 sq. ft.	SFR-Basic
00 106729 RK	R-5	Rural-5 Acre	Single Family Res-Combo

Accessory Dwelling Units

Index # - File Name: 1.0022 - Single Family Dwellings Data\_Snohomish County.pdf

00 104500 RK	R-5	Rural-5 Acre	Single Family Res-Combo
00 109596 RK	PRD-9,600	Residential 9,600 sq. ft.	SFR-Basic
00 109599 RK	PRD-9,600	Residential 9,600 sq. ft.	SFR-Basic
00 106036 RK	PRD-9,600	Residential 9,600 sq. ft.	Single Family Res-Combo
00 107261 RK	PRD-9,600	Residential 9,600 sq. ft.	SFR-Basic
00 109669 RK	PRD-9,600	Residential 9,600 sq. ft.	SFR-Basic
00 108378 RK	PRD-9,600	Residential 9,600 sq. ft.	SFR-Basic
00 109597 RK	PRD-9,600	Residential 9,600 sq. ft.	SFR-Basic
00 107986 RK	PRD-9,600	Residential 9,600 sq. ft.	Single Family Res-Combo
00 109595 RK	PRD-9,600	Residential 9,600 sq. ft.	SFR-Basic
00 110289 RK	PRD-9,600	Residential 9,600 sq. ft.	SFR-Basic
00 108379 RK	PRD-9,600	Residential 9,600 sq. ft.	SFR-Basic
00 109670 RK	PRD-9,600	Residential 9,600 sq. ft.	SFR-Basic
00 109410 RK	PRD-9,600	Residential 9,600 sq. ft.	SFR-Basic
00 109408 RK	PRD-9,600	Residential 9,600 sq. ft.	SFR-Basic
00 108224 RK	PRD-9,600	Residential 9,600 sq. ft.	SFR-Basic
00 108225 RK	PRD-9,600	Residential 9,600 sq. ft.	SFR-Basic
00 108226 RK	PRD-9,600	Residential 9,600 sq. ft.	SFR-Basic
00 108227 RK	PRD-9,600	Residential 9,600 sq. ft.	SFR-Basic
00 107282 RK	PRD-9,600	Residential 9,600 sq. ft.	SFR-Basic
00 105874 RK	PRD-9,600	Residential 9,600 sq. ft.	SFR-Basic
00 109600 RK	PRD-9,600	Residential 9,600 sq. ft.	Single Family Res-Combo
00 106849 RK	PRD-9,600	Residential 9,600 sq. ft.	SFR-Basic
00 107284 RK	PRD-9,600	Residential 9,600 sq. ft.	SFR-Basic
00 103940 RK	PRD-9,600	Residential 9,600 sq. ft.	Single Family Res-Combo
00 107984 RK	PRD-9,600	Residential 9,600 sq. ft.	SFR-Basic
00 106850 RK	PRD-9,600	Residential 9,600 sq. ft.	SFR-Basic
00 107985 RK	PRD-9,600	Residential 9,600 sq. ft.	SFR-Basic
00 107982 RK	PRD-9,600	Residential 9,600 sq. ft.	SFR-Basic
00 104816 RK	R-5	Rural-5 Acre	Single Family Res-Combo
00 108220 RK	R-9,600	Residential 9,600 sq. ft.	SFR-Basic
00 108221 RK	R-9,600	Residential 9,600 sq. ft.	SFR-Basic
00 108383 RK	R-9,600	Residential 9,600 sq. ft.	SFR-Basic
00 108384 RK	R-9,600	Residential 9,600 sq. ft.	SFR-Basic
00 108820 RK	R-9,600	Residential 9,600 sq. ft.	SFR-Basic
00 109059 RK	R-9,600	Residential 9,600 sq. ft.	SFR-Basic
00 108380 RK	R-9,600	Residential 9,600 sq. ft.	SFR-Basic
00 109963 RK	R-9,600	Residential 9,600 sq. ft.	SFR-Basic
00 109057 RK	R-9,600	Residential 9,600 sq. ft.	SFR-Basic
00 106283 RK	R-9,600	Residential 9,600 sq. ft.	Single Family Res-Combo
00 107260 RK	R-9,600	Residential 9,600 sq. ft.	SFR-Basic
00 106666 RK	R-9,600	Residential 9,600 sq. ft.	SFR-Basic
00 109404 RK	R-9,600	Residential 9,600 sq. ft.	SFR-Basic
00 109965 RK	R-9,600	Residential 9,600 sq. ft.	SFR-Basic
00 109407 RK	R-9,600	Residential 9,600 sq. ft.	SFR-Basic
00 110375 RK	R-9,600	Residential 9,600 sq. ft.	SFR-Basic
00 108222 RK	R-9,600	Residential 9,600 sq. ft.	SFR-Basic

Accessory Dwelling Units

Index # - File Name: 1.0022 - Single Family Dwellings Data\_Snohomish County.pdf

00 108223 RK	R-9,600	Residential 9,600 sq. ft.	SFR-Basic
00 108219 RK	R-9,600	Residential 9,600 sq. ft.	SFR-Basic
00 108381 RK	R-9,600	Residential 9,600 sq. ft.	SFR-Basic
00 108382 RK	R-9,600	Residential 9,600 sq. ft.	SFR-Basic
00 108385 RK	R-9,600	Residential 9,600 sq. ft.	SFR-Basic
00 108616 RK	R-9,600	Residential 9,600 sq. ft.	SFR-Basic
00 108617 RK	R-9,600	Residential 9,600 sq. ft.	SFR-Basic
00 108618 RK	R-9,600	Residential 9,600 sq. ft.	SFR-Basic
00 104959 RK	R-9,600(PRD)	Residential 9,600 sq. ft.	SFR-Basic
00 104958 RK	R-9,600(PRD)	Residential 9,600 sq. ft.	SFR-Basic
00 105973 RK	R-9,600(PRD)	Residential 9,600 sq. ft.	SFR-Basic
00 105051 RK	R-9,600(PRD)	Residential 9,600 sq. ft.	SFR-Basic
00 105054 RK	R-9,600(PRD)	Residential 9,600 sq. ft.	SFR-Basic
00 104961 RK	R-9,600(PRD)	Residential 9,600 sq. ft.	SFR-Basic
00 104960 RK	R-9,600(PRD)	Residential 9,600 sq. ft.	SFR-Basic
00 105050 RK	R-9,600(PRD)	Residential 9,600 sq. ft.	SFR-Basic
00 105052 RK	R-9,600(PRD)	Residential 9,600 sq. ft.	SFR-Basic
00 107030 RK	R-9,600(PRD)	Residential 9,600 sq. ft.	SFR-Basic
00 105508 RK	R-9,600(PRD)	Residential 9,600 sq. ft.	SFR-Basic
00 105507 RK	R-9,600(PRD)	Residential 9,600 sq. ft.	SFR-Basic
00 105687 RK	R-9,600(PRD)	Residential 9,600 sq. ft.	SFR-Basic
00 105686 RK	R-9,600(PRD)	Residential 9,600 sq. ft.	SFR-Basic
00 106365 RK	R-9,600(PRD)	Residential 9,600 sq. ft.	SFR-Basic
00 107577 RK	R-9,600(PRD)	Residential 9,600 sq. ft.	SFR-Basic
00 107579 RK	R-9,600(PRD)	Residential 9,600 sq. ft.	SFR-Basic
00 107212 RK	R-9,600(PRD)	Residential 9,600 sq. ft.	SFR-Basic
00 106626 RK	R-9,600(PRD)	Residential 9,600 sq. ft.	SFR-Basic
00 104428 RK	R-9,600(PRD)	Residential 9,600 sq. ft.	Single Family Res-Combo
00 109017 RK	R-9,600(PRD)	Residential 9,600 sq. ft.	SFR-Basic
00 107162 RK	R-9,600(PRD)	Residential 9,600 sq. ft.	Single Family Res-Combo
00 107166 RK	R-9,600(PRD)	Residential 9,600 sq. ft.	Single Family Res-Combo
00 107163 RK	R-9,600(PRD)	Residential 9,600 sq. ft.	Single Family Res-Combo
00 107159 RK	R-9,600(PRD)	Residential 9,600 sq. ft.	Single Family Res-Combo
00 107576 RK	R-9,600(PRD)	Residential 9,600 sq. ft.	SFR-Basic
00 107164 RK	R-9,600(PRD)	Residential 9,600 sq. ft.	Single Family Res-Combo
00 107161 RK	R-9,600(PRD)	Residential 9,600 sq. ft.	Single Family Res-Combo
00 107761 RK	R-9,600(PRD)	Residential 9,600 sq. ft.	SFR-Basic
00 104425 RK	R-9,600(PRD)	Residential 9,600 sq. ft.	Single Family Res-Combo
00 104957 RK	R-9,600(PRD)	Residential 9,600 sq. ft.	SFR-Basic
00 106627 RK	R-9,600(PRD)	Residential 9,600 sq. ft.	SFR-Basic
00 107064 RK	R-9,600(PRD)	Residential 9,600 sq. ft.	SFR-Basic
00 104429 RK	R-9,600(PRD)	Residential 9,600 sq. ft.	Single Family Res-Combo
00 108212 RK	R-9,600(PRD)	Residential 9,600 sq. ft.	SFR-Basic
00 108746 RK	R-9,600(PRD)	Residential 9,600 sq. ft.	SFR-Basic
00 104426 RK	R-9,600(PRD)	Residential 9,600 sq. ft.	Single Family Res-Combo
00 107759 RK	R-9,600(PRD)	Residential 9,600 sq. ft.	SFR-Basic
00 107765 RK	R-9,600(PRD)	Residential 9,600 sq. ft.	SFR-Basic

Accessory Dwelling Units

Index # - File Name: 1.0022 - Single Family Dwellings Data\_Snohomish County.pdf

00 107211 RK	R-9,600(PRD)	Residential 9,600 sq. ft.	SFR-Basic
00 107766 RK	R-9,600(PRD)	Residential 9,600 sq. ft.	SFR-Basic
00 104424 RK	R-9,600(PRD)	Residential 9,600 sq. ft.	Single Family Res-Combo
00 108214 RK	R-9,600(PRD)	Residential 9,600 sq. ft.	Single Family Res-Combo
00 106366 RK	R-9,600(PRD)	Residential 9,600 sq. ft.	SFR-Basic
00 106630 RK	R-9,600(PRD)	Residential 9,600 sq. ft.	SFR-Basic
00 109200 RK	R-9,600(PRD)	Residential 9,600 sq. ft.	SFR-Basic
00 108745 RK	R-9,600(PRD)	Residential 9,600 sq. ft.	SFR-Basic
00 108744 RK	R-9,600(PRD)	Residential 9,600 sq. ft.	SFR-Basic
00 107763 RK	R-9,600(PRD)	Residential 9,600 sq. ft.	SFR-Basic
00 109019 RK	R-9,600(PRD)	Residential 9,600 sq. ft.	SFR-Basic
00 107762 RK	R-9,600(PRD)	Residential 9,600 sq. ft.	SFR-Basic
00 106807 RK	R-9,600(PRD)	Residential 9,600 sq. ft.	SFR-Basic
00 109927 RK	R-9,600(PRD)	Residential 9,600 sq. ft.	SFR-Basic
00 109199 RK	R-9,600(PRD)	Residential 9,600 sq. ft.	SFR-Basic
00 109018 RK	R-9,600(PRD)	Residential 9,600 sq. ft.	SFR-Basic
00 106805 RK	R-9,600(PRD)	Residential 9,600 sq. ft.	SFR-Basic
00 107389 RK	R-9,600(PRD)	Residential 9,600 sq. ft.	SFR-Basic
00 106806 RK	R-9,600(PRD)	Residential 9,600 sq. ft.	SFR-Basic
00 107764 RK	R-9,600(PRD)	Residential 9,600 sq. ft.	SFR-Basic
00 109016 RK	R-9,600(PRD)	Residential 9,600 sq. ft.	SFR-Basic
00 109928 RK	R-9,600(PRD)	Residential 9,600 sq. ft.	SFR-Basic
00 107392 RK	R-9,600(PRD)	Residential 9,600 sq. ft.	SFR-Basic
00 106809 RK	R-9,600(PRD)	Residential 9,600 sq. ft.	SFR-Basic
00 108128 RK	R-9,600(PRD)	Residential 9,600 sq. ft.	SFR-Basic
00 106808 RK	R-9,600(PRD)	Residential 9,600 sq. ft.	SFR-Basic
00 104361 RK	R-5	Rural-5 Acre	Single Family Res-Combo
00 105969 RK	R-8,400	Residential 8,400 sq. ft.	SFR-Basic
00 105968 RK	R-8,400	Residential 8,400 sq. ft.	SFR-Basic
00 105964 RK	R-8,400	Residential 8,400 sq. ft.	SFR-Basic
00 105746 RK	R-5	Rural-5 Acre	Single Family Res-Combo
00 105723 RK	R-9,600	Residential 9,600 sq. ft.	Single Family Res-Combo
00 107421 RK	PRD-9,600	Residential 9,600 sq. ft.	SFR-Basic
00 107422 RK	PRD-9,600	Residential 9,600 sq. ft.	SFR-Basic
00 107424 RK	PRD-9,600	Residential 9,600 sq. ft.	SFR-Basic
00 107106 RK	PRD-9,600	Residential 9,600 sq. ft.	SFR-Basic
00 107107 RK	PRD-9,600	Residential 9,600 sq. ft.	SFR-Basic
00 107108 RK	PRD-9,600	Residential 9,600 sq. ft.	SFR-Basic
00 107109 RK	PRD-9,600	Residential 9,600 sq. ft.	SFR-Basic
00 106799 RK	PRD-9,600	Residential 9,600 sq. ft.	SFR-Basic
00 106800 RK	PRD-9,600	Residential 9,600 sq. ft.	SFR-Basic
00 107646 RK	PRD-9,600	Residential 9,600 sq. ft.	SFR-Basic
00 107647 RK	PRD-9,600	Residential 9,600 sq. ft.	SFR-Basic
00 107648 RK	PRD-9,600	Residential 9,600 sq. ft.	SFR-Basic
00 107649 RK	PRD-9,600	Residential 9,600 sq. ft.	SFR-Basic
00 108254 RK	PRD-9,600	Residential 9,600 sq. ft.	SFR-Basic
00 107850 RK	PRD-9,600	Residential 9,600 sq. ft.	SFR-Basic

Accessory Dwelling Units

Index # - File Name: 1.0022 - Single Family Dwellings Data\_Snohomish County.pdf

00 107849 RK	PRD-9,600	Residential 9,600 sq. ft.	SFR-Basic
00 108708 RK	PRD-9,600	Residential 9,600 sq. ft.	SFR-Basic
00 108709 RK	PRD-9,600	Residential 9,600 sq. ft.	SFR-Basic
00 108707 RK	PRD-9,600	Residential 9,600 sq. ft.	SFR-Basic
00 108706 RK	PRD-9,600	Residential 9,600 sq. ft.	SFR-Basic
00 109557 RK	PRD-9,600	Residential 9,600 sq. ft.	SFR-Basic
00 109559 RK	PRD-9,600	Residential 9,600 sq. ft.	SFR-Basic
00 109328 RK	PRD-9,600	Residential 9,600 sq. ft.	SFR-Basic
00 109558 RK	PRD-9,600	Residential 9,600 sq. ft.	SFR-Basic
00 109560 RK	PRD-9,600	Residential 9,600 sq. ft.	SFR-Basic
00 109556 RK	PRD-9,600	Residential 9,600 sq. ft.	SFR-Basic
00 109811 RK	PRD-9,600	Residential 9,600 sq. ft.	SFR-Basic
00 109138 RK	PRD-9,600	Residential 9,600 sq. ft.	SFR-Basic
00 109143 RK	PRD-9,600	Residential 9,600 sq. ft.	SFR-Basic
00 109815 RK	PRD-9,600	Residential 9,600 sq. ft.	SFR-Basic
00 106354 RK	PRD-9,600	Residential 9,600 sq. ft.	SFR-Basic
00 106355 RK	PRD-9,600	Residential 9,600 sq. ft.	SFR-Basic
00 106356 RK	PRD-9,600	Residential 9,600 sq. ft.	SFR-Basic
00 106357 RK	PRD-9,600	Residential 9,600 sq. ft.	SFR-Basic
00 106798 RK	PRD-9,600	Residential 9,600 sq. ft.	SFR-Basic
00 106801 RK	PRD-9,600	Residential 9,600 sq. ft.	SFR-Basic
00 107978 RK	PRD-9,600	Residential 9,600 sq. ft.	SFR-Basic
00 107976 RK	PRD-9,600	Residential 9,600 sq. ft.	SFR-Basic
00 107925 RK	PRD-9,600	Residential 9,600 sq. ft.	SFR-Basic
00 107927 RK	PRD-9,600	Residential 9,600 sq. ft.	SFR-Basic
00 107926 RK	PRD-9,600	Residential 9,600 sq. ft.	SFR-Basic
00 107928 RK	PRD-9,600	Residential 9,600 sq. ft.	SFR-Basic
00 107851 RK	PRD-9,600	Residential 9,600 sq. ft.	SFR-Basic
00 107848 RK	PRD-9,600	Residential 9,600 sq. ft.	SFR-Basic
00 109144 RK	PRD-9,600	Residential 9,600 sq. ft.	SFR-Basic
00 109142 RK	PRD-9,600	Residential 9,600 sq. ft.	SFR-Basic
00 109813 RK	PRD-9,600	Residential 9,600 sq. ft.	SFR-Basic
00 109821 RK	PRD-9,600	Residential 9,600 sq. ft.	SFR-Basic
00 109814 RK	PRD-9,600	Residential 9,600 sq. ft.	SFR-Basic
00 109140 RK	PRD-9,600	Residential 9,600 sq. ft.	SFR-Basic
00 109817 RK	PRD-9,600	Residential 9,600 sq. ft.	SFR-Basic
00 109820 RK	PRD-9,600	Residential 9,600 sq. ft.	SFR-Basic
00 108747 RK	R-9,600(PRD)	Residential 9,600 sq. ft.	SFR-Basic
00 108127 RK	R-9,600(PRD)	Residential 9,600 sq. ft.	SFR-Basic
00 108129 RK	R-9,600(PRD)	Residential 9,600 sq. ft.	SFR-Basic
00 107388 RK	R-9,600(PRD)	Residential 9,600 sq. ft.	SFR-Basic
00 107906 RK	R-7,200	Residential 7,200 sq. ft.	Single Family Res-Combo
00 108409 RK	R-7,200	Residential 7,200 sq. ft.	Single Family Res-Combo
00 110268 RK	R-7,200	Residential 7,200 sq. ft.	SFR-Basic
00 107459 RK	R-7,200	Residential 7,200 sq. ft.	SFR-Basic
00 107457 RK	R-7,200	Residential 7,200 sq. ft.	SFR-Basic
00 110155 RK	R-7,200	Residential 7,200 sq. ft.	Single Family Res-Combo



Accessory Dwelling Units

Index # - File Name: 1.0022 - Single Family Dwellings Data\_Snohomish County.pdf

00 107903 RK	R-7,200	Residential 7,200 sq. ft.	Single Family Res-Combo
00 107461 RK	R-7,200	Residential 7,200 sq. ft.	SFR-Basic
00 107463 RK	R-7,200	Residential 7,200 sq. ft.	SFR-Basic
00 105762 MH	R-5	Rural-5 Acre	Double Wide
00 108120 RK	CITY	City	SFR-Basic
00 106401 RK	CITY	City	SFR-Basic
00 107901 RK	CITY	City	SFR-Basic
00 108116 RK	CITY	City	SFR-Basic
00 107902 RK	CITY	City	SFR-Basic
00 107904 RK	CITY	City	SFR-Basic
00 107899 RK	CITY	City	SFR-Basic
00 108119 RK	CITY	City	SFR-Basic
00 106407 RK	CITY	City	SFR-Basic
00 108121 RK	CITY	City	SFR-Basic
99 113889 RK	R-9,600	Residential 9,600 sq. ft.	Single Family Res-Combo
00 105996 MH	R-5	Rural-5 Acre	Double Wide
00 106089 MH	R-5	Rural-5 Acre	Double Wide
00 106403 RK	CITY	City	SFR-Basic
00 106398 RK	CITY	City	SFR-Basic
00 106399 RK	CITY	City	SFR-Basic
00 107905 RK	CITY	City	SFR-Basic
00 106856 RK	PRD-7,200	Residential 7,200 sq. ft.	SFR-Basic
00 107479 RK	PRD-7,200	Residential 7,200 sq. ft.	SFR-Basic
00 103601 RK	PRD-7,200	Residential 7,200 sq. ft.	Single Family Res-Combo
00 103599 RK	PRD-7,200	Residential 7,200 sq. ft.	Single Family Res-Combo
00 106755 RK	PRD-7,200	Residential 7,200 sq. ft.	SFR-Basic
00 103597 RK	PRD-7,200	Residential 7,200 sq. ft.	Single Family Res-Combo
00 106759 RK	PRD-7,200	Residential 7,200 sq. ft.	SFR-Basic
00 107483 RK	PRD-7,200	Residential 7,200 sq. ft.	SFR-Basic
00 103598 RK	PRD-7,200	Residential 7,200 sq. ft.	Single Family Res-Combo
00 103600 RK	PRD-7,200	Residential 7,200 sq. ft.	Single Family Res-Combo
00 107480 RK	PRD-7,200	Residential 7,200 sq. ft.	SFR-Basic
00 107484 RK	PRD-7,200	Residential 7,200 sq. ft.	SFR-Basic
00 107486 RK	PRD-7,200	Residential 7,200 sq. ft.	SFR-Basic
00 104355 RK	R-8,400	Residential 8,400 sq. ft.	Single Family Res-Combo
00 104714 RK	PRD-7,200	Residential 7,200 sq. ft.	Single Family Res-Combo
99 110398 RK	PRD-7,200	Residential 7,200 sq. ft.	Single Family Res-Combo
00 103948 RK	PRD-7,200	Residential 7,200 sq. ft.	Single Family Res-Combo
00 106442 RK	PRD-7,200	Residential 7,200 sq. ft.	SFR-Basic
00 106444 RK	PRD-7,200	Residential 7,200 sq. ft.	SFR-Basic
99 110401 RK	PRD-7,200	Residential 7,200 sq. ft.	Single Family Res-Combo
00 103955 RK	PRD-7,200	Residential 7,200 sq. ft.	SFR-Basic
00 107153 RK	PRD-7,200	Residential 7,200 sq. ft.	SFR-Basic
00 107154 RK	PRD-7,200	Residential 7,200 sq. ft.	SFR-Basic
00 107801 RK	PRD-7,200	Residential 7,200 sq. ft.	SFR-Basic
00 107802 RK	PRD-7,200	Residential 7,200 sq. ft.	SFR-Basic
00 107803 RK	PRD-7,200	Residential 7,200 sq. ft.	SFR-Basic

Accessory Dwelling Units

Index # - File Name: 1.0022 - Single Family Dwellings Data\_Snohomish County.pdf

00 108581 RK	PRD-7,200	Residential 7,200 sq. ft.	SFR-Basic
00 108603 RK	PRD-7,200	Residential 7,200 sq. ft.	SFR-Basic
00 108604 RK	PRD-7,200	Residential 7,200 sq. ft.	SFR-Basic
00 106408 RK	CITY	City	SFR-Basic
00 106409 RK	CITY	City	SFR-Basic
00 104945 RK	R-8,400	Residential 8,400 sq. ft.	Single Family Res-Combo
00 106572 RK	R-5	Rural-5 Acre	Single Family Res-Combo
00 106575 RK	R-5	Rural-5 Acre	Single Family Res-Combo
00 106855 RK	R-7,200	Residential 7,200 sq. ft.	Single Family Res-Combo
00 108071 RK	R-5	Rural-5 Acre	Single Family Res-Combo
00 108069 RK	R-5	Rural-5 Acre	Single Family Res-Combo
00 108713 RK	R-5	Rural-5 Acre	Single Family Res-Combo
00 107038 RK	F	Forestry	Single Family Res-Combo
00 107195 RK	R-8,400	Residential 8,400 sq. ft.	Duplex-Basic
00 107205 RK			Duplex-Basic
00 104218 RK	R-7,200	Residential 7,200 sq. ft.	SFR-Basic
00 101657 RK	R-7,200	Residential 7,200 sq. ft.	Single Family Res-Combo
00 110127 RK	R-7,200	Residential 7,200 sq. ft.	SFR-Basic
00 101200 RK	R-7,200	Residential 7,200 sq. ft.	Single Family Res-Combo
00 102594 RK	R-7,200	Residential 7,200 sq. ft.	SFR-Basic
00 106311 RK	R-7,200	Residential 7,200 sq. ft.	SFR-Basic
00 101201 RK	R-7,200	Residential 7,200 sq. ft.	Single Family Res-Combo
00 100972 RK	R-7,200	Residential 7,200 sq. ft.	SFR-Basic
00 100971 RK	R-7,200	Residential 7,200 sq. ft.	SFR-Basic
00 100861 RK	PRD-7,200	Residential 7,200 sq. ft.	Single Family Res-Combo
00 100864 RK	PRD-7,200	Residential 7,200 sq. ft.	Single Family Res-Combo
00 101816 RK	PRD-7,200	Residential 7,200 sq. ft.	SFR-Basic
00 101212 RK	PRD-9,600	Residential 9,600 sq. ft.	SFR-Basic
00 101237 RK	PRD-9,600	Residential 9,600 sq. ft.	SFR-Basic
00 101218 RK	PRD-9,600	Residential 9,600 sq. ft.	SFR-Basic
00 101220 RK	PRD-9,600	Residential 9,600 sq. ft.	SFR-Basic
00 101213 RK	PRD-9,600	Residential 9,600 sq. ft.	SFR-Basic
00 100884 RK	PRD-9,600	Residential 9,600 sq. ft.	SFR-Basic
00 100882 RK	PRD-9,600	Residential 9,600 sq. ft.	Single Family Res-Combo
00 101214 RK	PRD-9,600	Residential 9,600 sq. ft.	SFR-Basic
00 101265 RK	PRD-9,600	Residential 9,600 sq. ft.	SFR-Basic
00 101217 RK	PRD-9,600	Residential 9,600 sq. ft.	SFR-Basic
00 101236 RK	PRD-9,600	Residential 9,600 sq. ft.	SFR-Basic
00 101219 RK	PRD-9,600	Residential 9,600 sq. ft.	SFR-Basic
00 101215 RK	PRD-9,600	Residential 9,600 sq. ft.	SFR-Basic
00 100982 RK	PRD-9,600	Residential 9,600 sq. ft.	SFR-Basic
00 101216 RK	PRD-9,600	Residential 9,600 sq. ft.	SFR-Basic
00 102861 RK	PRD-9,600	Residential 9,600 sq. ft.	SFR-Basic
00 102780 RK	PRD-9,600	Residential 9,600 sq. ft.	SFR-Basic
00 101884 RK	PRD-9,600	Residential 9,600 sq. ft.	SFR-Basic
00 101888 RK	PRD-9,600	Residential 9,600 sq. ft.	SFR-Basic
00 101894 RK	PRD-9,600	Residential 9,600 sq. ft.	SFR-Basic

Accessory Dwelling Units

Index # - File Name: 1.0022 - Single Family Dwellings Data\_Snohomish County.pdf

00 102864 RK	PRD-9,600	Residential 9,600 sq. ft.	SFR-Basic
00 101885 RK	PRD-9,600	Residential 9,600 sq. ft.	SFR-Basic
00 101886 RK	PRD-9,600	Residential 9,600 sq. ft.	SFR-Basic
00 101896 RK	PRD-9,600	Residential 9,600 sq. ft.	SFR-Basic
00 102975 RK	PRD-9,600	Residential 9,600 sq. ft.	SFR-Basic
00 101895 RK	PRD-9,600	Residential 9,600 sq. ft.	SFR-Basic
00 101890 RK	PRD-9,600	Residential 9,600 sq. ft.	SFR-Basic
00 101887 RK	PRD-9,600	Residential 9,600 sq. ft.	SFR-Basic
99 116207 RK	PRD-9,600	Residential 9,600 sq. ft.	Single Family Res-Combo
99 115749 RK	PRD-9,600	Residential 9,600 sq. ft.	Single Family Res-Combo
99 116166 RK	PRD-9,600	Residential 9,600 sq. ft.	Single Family Res-Combo
99 116165 RK	PRD-9,600	Residential 9,600 sq. ft.	Single Family Res-Combo
99 115501 RK	R-7,200	Residential 7,200 sq. ft.	Single Family Res-Combo
99 115495 RK	R-7,200	Residential 7,200 sq. ft.	SFR-Basic
99 115407 MH	R-5	Rural-5 Acre	Double Wide
99 115462 RK	R-9,600	Residential 9,600 sq. ft.	Single Family Res-Combo
00 101113 RK	CITY	City	SFR-Basic
99 115387 RK	CITY	City	SFR-Basic
99 115066 RK	CITY	City	SFR-Basic
99 115070 RK	CITY	City	SFR-Basic
99 114854 RK	R-5	Rural-5 Acre	Single Family Res-Combo
99 115255 RK	R-5	Rural-5 Acre	Single Family Res-Combo
99 116160 RK	CITY	City	SFR-Basic
99 116161 RK	CITY	City	SFR-Basic
00 102440 RK	CITY	City	SFR-Basic
00 102442 RK	CITY	City	SFR-Basic
00 102441 RK	CITY	City	SFR-Basic
00 101316 RK	CITY	City	SFR-Basic
00 101322 RK	CITY	City	SFR-Basic
00 101315 RK	CITY	City	SFR-Basic
00 101317 RK	CITY	City	SFR-Basic
00 101319 RK	CITY	City	SFR-Basic
99 116020 RK	CITY	City	SFR-Basic
99 116018 RK	CITY	City	SFR-Basic
99 116420 RK	CITY	City	SFR-Basic
00 103007 RK	CITY	City	SFR-Basic
00 103008 RK	CITY	City	SFR-Basic
00 103010 RK	CITY	City	SFR-Basic
99 116159 RK	CITY	City	SFR-Basic
00 103022 RK	CITY	City	SFR-Basic
99 116419 RK	CITY	City	SFR-Basic
99 116021 RK	CITY	City	SFR-Basic
99 116017 RK	CITY	City	SFR-Basic
00 105340 RK	LDMR	Low Density Multiple Reside	SFR-Basic
00 105337 RK	LDMR	Low Density Multiple Reside	SFR-Basic
00 105894 RK	LDMR	Low Density Multiple Reside	SFR-Basic
00 105905 RK	LDMR	Low Density Multiple Reside	SFR-Basic

Accessory Dwelling Units

Index # - File Name: 1.0022 - Single Family Dwellings Data\_Snohomish County.pdf

00 105916 RK	LDMR	Low Density Multiple Reside SFR-Basic
00 105912 RK	LDMR	Low Density Multiple Reside SFR-Basic
00 105869 RK	LDMR	Low Density Multiple Reside SFR-Basic
00 105893 RK	LDMR	Low Density Multiple Reside SFR-Basic
00 105897 RK	LDMR	Low Density Multiple Reside SFR-Basic
00 105898 RK	LDMR	Low Density Multiple Reside SFR-Basic
00 105908 RK	LDMR	Low Density Multiple Reside SFR-Basic
99 112744 RK	LDMR	Low Density Multiple Reside Single Family Res-Combo
99 112748 RK	LDMR	Low Density Multiple Reside Single Family Res-Combo
99 112747 RK	LDMR	Low Density Multiple Reside Single Family Res-Combo
99 113365 RK	LDMR	Low Density Multiple Reside Single Family Res-Combo
00 105918 RK	LDMR	Low Density Multiple Reside SFR-Basic
00 105914 RK	LDMR	Low Density Multiple Reside SFR-Basic
00 105915 RK	LDMR	Low Density Multiple Reside SFR-Basic
00 105919 RK	LDMR	Low Density Multiple Reside SFR-Basic
00 105870 RK	LDMR	Low Density Multiple Reside SFR-Basic
99 115267 MH	R-5	Rural-5 Acre Double Wide
00 104701 MH	R-5	Rural-5 Acre Double Wide
00 105921 RK	LDMR	Low Density Multiple Reside SFR-Basic
00 105911 RK	LDMR	Low Density Multiple Reside SFR-Basic
00 105900 RK	LDMR	Low Density Multiple Reside SFR-Basic
99 112750 RK	LDMR	Low Density Multiple Reside Single Family Res-Combo
00 105901 RK	LDMR	Low Density Multiple Reside SFR-Basic
99 113367 RK	LDMR	Low Density Multiple Reside Single Family Res-Combo
00 105910 RK	LDMR	Low Density Multiple Reside SFR-Basic
00 105920 RK	LDMR	Low Density Multiple Reside SFR-Basic
00 105868 RK	LDMR	Low Density Multiple Reside SFR-Basic
00 105895 RK	LDMR	Low Density Multiple Reside SFR-Basic
00 105906 RK	LDMR	Low Density Multiple Reside SFR-Basic
00 105917 RK	LDMR	Low Density Multiple Reside SFR-Basic
00 105907 RK	LDMR	Low Density Multiple Reside SFR-Basic
00 105871 RK	LDMR	Low Density Multiple Reside SFR-Basic
00 105872 RK	LDMR	Low Density Multiple Reside SFR-Basic
99 104850 MH	R-5	Rural-5 Acre Double Wide
00 103764 RK	R-5	Rural-5 Acre Single Family Res-Combo
00 108359 RK	CITY	City SFR-Basic
00 108357 RK	CITY	City SFR-Basic
00 105279 RK	CITY	City SFR-Basic
00 105282 RK	CITY	City SFR-Basic
00 105278 RK	CITY	City SFR-Basic
00 105280 RK	CITY	City SFR-Basic
00 105283 RK	CITY	City SFR-Basic
00 105276 RK	CITY	City SFR-Basic
00 105284 RK	CITY	City SFR-Basic
00 105281 RK	CITY	City SFR-Basic
00 104012 RK	CITY	City SFR-Basic
00 104011 RK	CITY	City SFR-Basic

Accessory Dwelling Units

Index # - File Name: 1.0022 - Single Family Dwellings Data\_Snohomish County.pdf

00 104013 RK	CITY	City	SFR-Basic
00 103003 RK	CITY	City	SFR-Basic
00 102355 RK	CITY	City	SFR-Basic
00 102354 RK	CITY	City	SFR-Basic
00 107032 RK	CITY	City	SFR-Basic
00 107033 RK	CITY	City	SFR-Basic
00 107034 RK	CITY	City	SFR-Basic
00 107035 RK	CITY	City	SFR-Basic
00 105274 RK	CITY	City	SFR-Basic
00 104962 RK	CITY	City	SFR-Basic
00 104836 RK	CITY	City	SFR-Basic
00 104719 RK	CITY	City	SFR-Basic
00 104835 RK	CITY	City	SFR-Basic
00 104837 RK	CITY	City	SFR-Basic
00 104718 RK	CITY	City	SFR-Basic
00 104720 RK	CITY	City	SFR-Basic
00 103002 RK	CITY	City	SFR-Basic
00 102567 RK	CITY	City	SFR-Basic
00 102879 RK	CITY	City	SFR-Basic
00 104243 RK	CITY	City	SFR-Basic
00 103977 RK	CITY	City	SFR-Basic
00 104241 RK	CITY	City	SFR-Basic
00 104242 RK	CITY	City	SFR-Basic
00 104240 RK	CITY	City	SFR-Basic
00 103976 RK	CITY	City	SFR-Basic
00 102568 RK	CITY	City	SFR-Basic
00 102569 RK	CITY	City	SFR-Basic
00 102882 RK	CITY	City	SFR-Basic
00 103001 RK	CITY	City	SFR-Basic
00 103238 RK	CITY	City	SFR-Basic
00 103235 RK	CITY	City	SFR-Basic
00 103240 RK	CITY	City	SFR-Basic
00 103234 RK	CITY	City	SFR-Basic
00 100531 RK	CITY	City	SFR-Basic
00 101682 RK	CITY	City	SFR-Basic
00 103241 RK	CITY	City	SFR-Basic
00 102763 RK	CITY	City	SFR-Basic
00 102999 RK	CITY	City	SFR-Basic
00 101679 RK	CITY	City	SFR-Basic
00 101681 RK	CITY	City	SFR-Basic
00 101684 RK	CITY	City	SFR-Basic
00 101678 RK	CITY	City	SFR-Basic
00 102170 RK	CITY	City	SFR-Basic
99 116164 RK	CITY	City	SFR-Basic
00 102765 RK	CITY	City	SFR-Basic
00 103610 RK	CITY	City	SFR-Basic
00 103608 RK	CITY	City	SFR-Basic

Accessory Dwelling Units

Index # - File Name: 1.0022 - Single Family Dwellings Data\_Snohomish County.pdf

00 104717 RK	CITY	City	SFR-Basic
99 116417 RK	CITY	City	SFR-Basic
99 116163 RK	CITY	City	SFR-Basic
99 116173 RK	CITY	City	Single Family Res-Combo
99 116162 RK	CITY	City	Single Family Res-Combo
99 115865 RK	CITY	City	Single Family Res-Combo
00 102171 RK	CITY	City	SFR-Basic
00 102168 RK	CITY	City	SFR-Basic
00 102172 RK	CITY	City	SFR-Basic
00 103236 RK	CITY	City	SFR-Basic
00 103239 RK	CITY	City	SFR-Basic
00 104010 RK	CITY	City	SFR-Basic
00 102353 RK	CITY	City	SFR-Basic
00 102352 RK	CITY	City	SFR-Basic
00 100529 RK	CITY	City	SFR-Basic
00 102002 RK	CITY	City	Single Family Res-Combo
00 102766 RK	CITY	City	SFR-Basic
00 102173 RK	CITY	City	SFR-Basic
99 116239 RK	CITY	City	SFR-Basic
99 116247 RK	CITY	City	SFR-Basic
99 116240 RK	CITY	City	SFR-Basic
99 116258 RK	CITY	City	SFR-Basic
99 115789 RK	CITY	City	Single Family Res-Combo
99 116251 RK	CITY	City	SFR-Basic
99 116252 RK	CITY	City	SFR-Basic
99 116248 RK	CITY	City	SFR-Basic
99 116253 RK	CITY	City	SFR-Basic
99 116269 RK	CITY	City	SFR-Basic
99 116254 RK	CITY	City	SFR-Basic
99 116259 RK	CITY	City	SFR-Basic
00 102335 RK	CITY	City	SFR-Basic
00 102332 RK	CITY	City	SFR-Basic
00 102337 RK	CITY	City	SFR-Basic
00 102333 RK	CITY	City	SFR-Basic
00 102334 RK	CITY	City	SFR-Basic
00 102338 RK	CITY	City	SFR-Basic
00 108512 RK	CITY	City	SFR-Basic
00 108514 RK	CITY	City	SFR-Basic
00 108515 RK	CITY	City	SFR-Basic
00 108516 RK	CITY	City	SFR-Basic
00 108517 RK	CITY	City	SFR-Basic
00 108526 RK	CITY	City	SFR-Basic
00 108527 RK	CITY	City	SFR-Basic
00 108530 RK	CITY	City	SFR-Basic
00 108531 RK	CITY	City	SFR-Basic
00 108528 RK	CITY	City	SFR-Basic
00 108529 RK	CITY	City	SFR-Basic

Accessory Dwelling Units

Index # - File Name: 1.0022 - Single Family Dwellings Data\_Snohomish County.pdf

00 108518 RK	CITY	City	SFR-Basic
00 108519 RK	CITY	City	SFR-Basic
00 108520 RK	CITY	City	SFR-Basic
00 108521 RK	CITY	City	SFR-Basic
00 108522 RK	CITY	City	SFR-Basic
00 105940 RK	CITY	City	SFR-Basic
00 105941 RK	CITY	City	SFR-Basic
00 105942 RK	CITY	City	SFR-Basic
00 105943 RK	CITY	City	SFR-Basic
00 105944 RK	CITY	City	SFR-Basic
00 105945 RK	CITY	City	SFR-Basic
00 105946 RK	CITY	City	SFR-Basic
00 105947 RK	CITY	City	SFR-Basic
00 105948 RK	CITY	City	SFR-Basic
00 105949 RK	CITY	City	SFR-Basic
00 105950 RK	CITY	City	SFR-Basic
00 105951 RK	CITY	City	SFR-Basic
00 108523 RK	CITY	City	SFR-Basic
00 108524 RK	CITY	City	SFR-Basic
00 104501 RK	CITY	City	SFR-Basic
00 103980 RK	CITY	City	SFR-Basic
00 103978 RK	CITY	City	SFR-Basic
00 108294 RK	CITY	City	SFR-Basic
99 116260 RK	CITY	City	SFR-Basic
99 116241 RK	CITY	City	SFR-Basic
99 116261 RK	CITY	City	SFR-Basic
99 116242 RK	CITY	City	SFR-Basic
99 116255 RK	CITY	City	SFR-Basic
99 116264 RK	CITY	City	SFR-Basic
99 116256 RK	CITY	City	SFR-Basic
99 116249 RK	CITY	City	SFR-Basic
99 116243 RK	CITY	City	SFR-Basic
99 116265 RK	CITY	City	SFR-Basic
99 116244 RK	CITY	City	SFR-Basic
99 116266 RK	CITY	City	SFR-Basic
99 116267 RK	CITY	City	SFR-Basic
99 116245 RK	CITY	City	SFR-Basic
99 116268 RK	CITY	City	SFR-Basic
99 116257 RK	CITY	City	SFR-Basic
99 116246 RK	CITY	City	SFR-Basic
99 116250 RK	CITY	City	SFR-Basic
00 101530 RK	PRD-7,200	Residential 7,200 sq. ft.	SFR-Basic
00 101618 RK	PRD-7,200	Residential 7,200 sq. ft.	SFR-Basic
00 101617 RK	PRD-7,200	Residential 7,200 sq. ft.	SFR-Basic
00 100643 RK	PRD-7,200	Residential 7,200 sq. ft.	SFR-Basic
00 100644 RK	PRD-7,200	Residential 7,200 sq. ft.	SFR-Basic
00 105299 RK	PRD-7,200	Residential 7,200 sq. ft.	SFR-Basic

Accessory Dwelling Units

Index # - File Name: 1.0022 - Single Family Dwellings Data\_Snohomish County.pdf

00 106174 RK	PRD-7,200	Residential 7,200 sq. ft.	SFR-Basic
00 106844 RK	PRD-7,200	Residential 7,200 sq. ft.	SFR-Basic
00 106848 RK	PRD-7,200	Residential 7,200 sq. ft.	SFR-Basic
00 106175 RK	PRD-7,200	Residential 7,200 sq. ft.	SFR-Basic
00 105298 RK	PRD-7,200	Residential 7,200 sq. ft.	SFR-Basic
00 102320 RK	PRD-7,200	Residential 7,200 sq. ft.	SFR-Basic
00 102323 RK	PRD-7,200	Residential 7,200 sq. ft.	SFR-Basic
00 101103 RK	PRD-7,200	Residential 7,200 sq. ft.	Single Family Res-Combo
99 116047 RK	PRD-7,200	Residential 7,200 sq. ft.	Single Family Res-Combo
99 116044 RK	PRD-7,200	Residential 7,200 sq. ft.	Single Family Res-Combo
00 101430 RK	R-7,200	Residential 7,200 sq. ft.	Single Family Res-Combo
00 101130 RK	R-7,200	Residential 7,200 sq. ft.	SFR-Basic
99 116200 RK	R-7,200	Residential 7,200 sq. ft.	SFR-Basic
99 116202 RK	R-7,200	Residential 7,200 sq. ft.	SFR-Basic
99 116201 RK	R-7,200	Residential 7,200 sq. ft.	SFR-Basic
99 116199 RK	R-7,200	Residential 7,200 sq. ft.	SFR-Basic
99 116198 RK	R-7,200	Residential 7,200 sq. ft.	SFR-Basic
00 100476 RK	R-7,200	Residential 7,200 sq. ft.	Single Family Res-Combo
99 115270 RK	CITY	City	Single Family Res-Combo
00 102855 RK	CITY	City	SFR-Basic
00 102854 RK	CITY	City	SFR-Basic
00 102994 RK	CITY	City	SFR-Basic
99 116136 RK	R-8,400	Residential 8,400 sq. ft.	Single Family Res-Combo
99 116523 RK	R-5	Rural-5 Acre	Single Family Res-Combo
00 103583 RK	R-8,400	Residential 8,400 sq. ft.	SFR-Basic
00 103718 RK	R-8,400	Residential 8,400 sq. ft.	SFR-Basic
00 103582 RK	R-8,400	Residential 8,400 sq. ft.	SFR-Basic
99 114994 RK	R-5	Rural-5 Acre	SFR-Basic
99 114990 RK	R-5	Rural-5 Acre	SFR-Basic
99 116019 RK	CITY	City	SFR-Basic
00 103004 RK	CITY	City	SFR-Basic
00 103005 RK	CITY	City	SFR-Basic
00 103006 RK	CITY	City	SFR-Basic
00 103020 RK	CITY	City	SFR-Basic
00 101908 RK	CITY	City	SFR-Basic
00 101909 RK	CITY	City	SFR-Basic
99 115860 RK	CITY	City	SFR-Basic
99 115863 RK	CITY	City	SFR-Basic
99 115864 RK	CITY	City	SFR-Basic
99 115508 RK	CITY	City	SFR-Basic
00 100926 RK	R-8,400	Residential 8,400 sq. ft.	SFR-Basic
00 108320 RK	R-8,400	Residential 8,400 sq. ft.	SFR-Basic
00 108318 RK	R-8,400	Residential 8,400 sq. ft.	SFR-Basic
00 103021 RK	CITY	City	Duplex-Combo
99 116534 RK	CITY	City	Single Family Res-Combo
00 101495 RK	CITY	City	SFR-Basic
00 101496 RK	CITY	City	SFR-Basic



Accessory Dwelling Units

Index # - File Name: 1.0022 - Single Family Dwellings Data\_Snohomish County.pdf

00 101497 RK	CITY	City	SFR-Basic
99 116102 RK	CITY	City	Single Family Res-Combo
00 100939 RK	CITY	City	SFR-Basic
00 100940 RK	CITY	City	SFR-Basic
00 100941 RK	CITY	City	SFR-Basic
00 100942 RK	CITY	City	SFR-Basic
00 100943 RK	CITY	City	SFR-Basic
00 100944 RK	CITY	City	SFR-Basic
00 100945 RK	CITY	City	SFR-Basic
00 100946 RK	CITY	City	SFR-Basic
00 100947 RK	CITY	City	SFR-Basic
00 101499 RK	CITY	City	SFR-Basic
00 101500 RK	CITY	City	SFR-Basic
99 116533 RK	CITY	City	Single Family Res-Combo
00 108293 RK	CITY	City	SFR-Basic
00 108286 RK	CITY	City	SFR-Basic
00 102327 RK	CITY	City	SFR-Basic
00 102330 RK	CITY	City	SFR-Basic
00 102329 RK	CITY	City	SFR-Basic
00 102328 RK	CITY	City	SFR-Basic
00 100498 RK	CITY	City	SFR-Basic
00 108291 RK	CITY	City	SFR-Basic
00 100499 RK	CITY	City	SFR-Basic
00 100495 RK	CITY	City	SFR-Basic
00 100500 RK	CITY	City	SFR-Basic
00 100496 RK	CITY	City	SFR-Basic
00 100501 RK	CITY	City	SFR-Basic
00 100497 RK	CITY	City	SFR-Basic
00 100502 RK	CITY	City	SFR-Basic
00 100503 RK	CITY	City	SFR-Basic
99 115794 RK	R-5	Rural-5 Acre	Single Family Res-Combo
00 100853 RK	R-5	Rural-5 Acre	Single Family Res-Combo
99 115515 RK	CITY	City	SFR-Basic
99 115516 RK	CITY	City	SFR-Basic
99 115517 RK	CITY	City	SFR-Basic
99 115518 RK	CITY	City	SFR-Basic
99 115519 RK	CITY	City	SFR-Basic
99 115520 RK	CITY	City	SFR-Basic
99 115521 RK	CITY	City	SFR-Basic
99 115522 RK	CITY	City	SFR-Basic
99 115525 RK	CITY	City	SFR-Basic
99 115526 RK	CITY	City	SFR-Basic
00 100532 RK	CITY	City	SFR-Basic
99 115527 RK	CITY	City	SFR-Basic
99 115528 RK	CITY	City	SFR-Basic
99 115529 RK	CITY	City	SFR-Basic
99 115530 RK	CITY	City	SFR-Basic

Accessory Dwelling Units

Index # - File Name: 1.0022 - Single Family Dwellings Data\_Snohomish County.pdf

99 115531 RK	CITY	City	SFR-Basic
99 115532 RK	CITY	City	SFR-Basic
99 115533 RK	CITY	City	SFR-Basic
99 115534 RK	CITY	City	SFR-Basic
99 115535 RK	CITY	City	SFR-Basic
99 115536 RK	CITY	City	SFR-Basic
99 115537 RK	CITY	City	SFR-Basic
99 115538 RK	CITY	City	SFR-Basic
99 115539 RK	CITY	City	SFR-Basic
99 115540 RK	CITY	City	SFR-Basic
99 115541 RK	CITY	City	SFR-Basic
99 115542 RK	CITY	City	SFR-Basic
99 114781 RK	R-5	Rural-5 Acre	Single Family Res-Combo
00 106838 RK	R-7,200	Residential 7,200 sq. ft.	SFR-Basic
00 103737 RK	R-7,200	Residential 7,200 sq. ft.	SFR-Basic
99 112479 RK	R-7,200	Residential 7,200 sq. ft.	Single Family Res-Combo
00 101458 RK	R-7,200	Residential 7,200 sq. ft.	SFR-Basic
99 112483 RK	R-7,200	Residential 7,200 sq. ft.	Single Family Res-Combo
00 101019 RK	R-7,200	Residential 7,200 sq. ft.	Single Family Res-Combo
00 101456 RK	R-7,200	Residential 7,200 sq. ft.	Single Family Res-Combo
99 116039 RK	R-7,200	Residential 7,200 sq. ft.	SFR-Basic
00 101536 RK	R-7,200	Residential 7,200 sq. ft.	SFR-Basic
99 115563 RK	R-7,200	Residential 7,200 sq. ft.	Single Family Res-Combo
99 112482 RK	R-7,200	Residential 7,200 sq. ft.	Single Family Res-Combo
99 114670 RK	R-7,200	Residential 7,200 sq. ft.	SFR-Basic
00 101433 RK	R-5	Rural-5 Acre	Single Family Res-Combo
00 102154 RK	R-5	Rural-5 Acre	Single Family Res-Combo
99 112481 RK	R-7,200	Residential 7,200 sq. ft.	Single Family Res-Combo
00 107403 RK	R-7,200	Residential 7,200 sq. ft.	SFR-Basic
99 114929 RK	R-7,200	Residential 7,200 sq. ft.	SFR-Basic
00 103462 RK	R-5	Rural-5 Acre	Single Family Res-Combo
00 104004 RK	R-5	Rural-5 Acre	Single Family Res-Combo
00 106570 RK	R-5	Rural-5 Acre	Single Family Res-Combo
99 114298 RK	R-5	Rural-5 Acre	Single Family Res-Combo
00 100639 RK	R-9,600	Residential 9,600 sq. ft.	SFR-Basic
00 110024 RK	R-7,200	Residential 7,200 sq. ft.	Duplex-Basic
99 116052 RK	R-9,600	Residential 9,600 sq. ft.	Single Family Res-Combo
00 103932 RK	R-9,600	Residential 9,600 sq. ft.	Single Family Res-Combo
00 107842 RK	R-9,600	Residential 9,600 sq. ft.	SFR-Basic
00 105646 RK	R-9,600	Residential 9,600 sq. ft.	SFR-Basic
00 109345 RK	R-9,600	Residential 9,600 sq. ft.	Single Family Res-Combo
00 110065 RK	R-9,600	Residential 9,600 sq. ft.	SFR-Basic
99 114388 RK	R-9,600	Residential 9,600 sq. ft.	SFR-Basic
00 107005 RK	R-9,600	Residential 9,600 sq. ft.	Single Family Res-Combo
00 106088 RK	R-9,600	Residential 9,600 sq. ft.	SFR-Basic
00 104726 RK	R-9,600	Residential 9,600 sq. ft.	SFR-Basic
00 100832 RK	R-9,600	Residential 9,600 sq. ft.	SFR-Basic

Accessory Dwelling Units

Index # - File Name: 1.0022 - Single Family Dwellings Data\_Snohomish County.pdf

00 100830 RK	R-9,600	Residential 9,600 sq. ft.	SFR-Basic
00 101955 RK	R-9,600	Residential 9,600 sq. ft.	SFR-Basic
00 101957 RK	R-9,600	Residential 9,600 sq. ft.	SFR-Basic
00 103040 RK	R-9,600	Residential 9,600 sq. ft.	Single Family Res-Combo
00 102930 RK	R-9,600	Residential 9,600 sq. ft.	SFR-Basic
00 109289 RK	R-9,600	Residential 9,600 sq. ft.	SFR-Basic
00 103899 RK	R-5	Rural-5 Acre	Single Family Res-Combo
99 113896 RK	R-5	Rural-5 Acre	Single Family Res-Combo
00 102991 RK	PRD-9,600	Residential 9,600 sq. ft.	SFR-Basic
00 107499 RK	RRT-10	Rural Resource Transition-10	Single Family Res-Combo
00 107894 RK	RRT-10	Rural Resource Transition-10	Single Family Res-Combo
99 114059 RK	PRD-9,600	Residential 9,600 sq. ft.	SFR-Basic
99 114069 RK	PRD-9,600	Residential 9,600 sq. ft.	SFR-Basic
99 114055 RK	PRD-9,600	Residential 9,600 sq. ft.	SFR-Basic
99 114056 RK	PRD-9,600	Residential 9,600 sq. ft.	SFR-Basic
99 114061 RK	PRD-9,600	Residential 9,600 sq. ft.	SFR-Basic
99 114064 RK	PRD-9,600	Residential 9,600 sq. ft.	SFR-Basic
99 114068 RK	PRD-9,600	Residential 9,600 sq. ft.	SFR-Basic
00 110061 RK	PRD-9,600	Residential 9,600 sq. ft.	SFR-Basic
00 104968 RK	PRD-9,600	Residential 9,600 sq. ft.	SFR-Basic
00 100642 RK	PRD-9,600	Residential 9,600 sq. ft.	SFR-Basic
00 102693 RK	PRD-9,600	Residential 9,600 sq. ft.	SFR-Basic
00 102127 RK	PRD-9,600	Residential 9,600 sq. ft.	Single Family Res-Combo
00 103956 RK	PRD-9,600	Residential 9,600 sq. ft.	SFR-Basic
00 101491 RK	PRD-9,600	Residential 9,600 sq. ft.	SFR-Basic
99 115757 RK	PRD-9,600	Residential 9,600 sq. ft.	SFR-Basic
00 103717 RK	PRD-9,600	Residential 9,600 sq. ft.	SFR-Basic
00 102128 RK	PRD-9,600	Residential 9,600 sq. ft.	Single Family Res-Combo
00 100798 RK	PRD-9,600	Residential 9,600 sq. ft.	SFR-Basic
00 100641 RK	PRD-9,600	Residential 9,600 sq. ft.	SFR-Basic
00 108898 RK	PRD-9,600	Residential 9,600 sq. ft.	SFR-Basic
00 107532 RK	PRD-9,600	Residential 9,600 sq. ft.	SFR-Basic
00 107965 RK	PRD-9,600	Residential 9,600 sq. ft.	SFR-Basic
00 100922 RK	PRD-9,600	Residential 9,600 sq. ft.	SFR-Basic
00 110060 RK	PRD-9,600	Residential 9,600 sq. ft.	SFR-Basic
00 109185 RK	PRD-9,600	Residential 9,600 sq. ft.	SFR-Basic
00 102932 RK	PRD-9,600	Residential 9,600 sq. ft.	Single Family Res-Combo
00 107004 RK	PRD-9,600	Residential 9,600 sq. ft.	SFR-Basic
00 100482 RK	PRD-9,600	Residential 9,600 sq. ft.	Single Family Res-Combo
99 116230 RK	PRD-9,600	Residential 9,600 sq. ft.	SFR-Basic
99 116231 RK	PRD-9,600	Residential 9,600 sq. ft.	SFR-Basic
99 116410 RK	PRD-9,600	Residential 9,600 sq. ft.	SFR-Basic
00 100481 RK	PRD-9,600	Residential 9,600 sq. ft.	Single Family Res-Combo
00 105027 RK	PRD-9,600	Residential 9,600 sq. ft.	SFR-Basic
00 102126 RK	PRD-9,600	Residential 9,600 sq. ft.	Single Family Res-Combo
00 100797 RK	PRD-9,600	Residential 9,600 sq. ft.	SFR-Basic
00 103715 RK	PRD-9,600	Residential 9,600 sq. ft.	SFR-Basic

Accessory Dwelling Units

Index # - File Name: 1.0022 - Single Family Dwellings Data\_Snohomish County.pdf

00 100921 RK	PRD-9,600	Residential 9,600 sq. ft.	SFR-Basic
00 100811 RK	R-7,200	Residential 7,200 sq. ft.	Single Family Res-Combo
00 103045 RK	PRD-9,600	Residential 9,600 sq. ft.	Single Family Res-Combo
00 102123 RK	PRD-9,600	Residential 9,600 sq. ft.	Single Family Res-Combo
99 113433 RK	R-5	Rural-5 Acre	Single Family Res-Combo
99 113525 RK	R-5	Rural-5 Acre	Single Family Res-Combo
00 100920 RK	PRD-9,600	Residential 9,600 sq. ft.	SFR-Basic
00 101766 RK	PRD-9,600	Residential 9,600 sq. ft.	SFR-Basic
00 105028 RK	PRD-9,600	Residential 9,600 sq. ft.	SFR-Basic
00 102692 RK	PRD-9,600	Residential 9,600 sq. ft.	SFR-Basic
99 116409 RK	PRD-9,600	Residential 9,600 sq. ft.	SFR-Basic
00 103954 RK	PRD-9,600	Residential 9,600 sq. ft.	SFR-Basic
00 100799 RK	PRD-9,600	Residential 9,600 sq. ft.	SFR-Basic
00 102992 RK	PRD-9,600	Residential 9,600 sq. ft.	SFR-Basic
00 103952 RK	PRD-9,600	Residential 9,600 sq. ft.	SFR-Basic
00 103957 RK	PRD-9,600	Residential 9,600 sq. ft.	SFR-Basic
00 106642 RK	A-10 : R-5	Agriculture-10 Acre : Rural-5	Single Family Res-Combo
99 113298 MH	R-5	Rural-5 Acre	Double Wide
00 102517 RK	PRD-9,600	Residential 9,600 sq. ft.	Single Family Res-Combo
00 100913 RK	PRD-9,600	Residential 9,600 sq. ft.	SFR-Basic
00 102516 RK	PRD-9,600	Residential 9,600 sq. ft.	Single Family Res-Combo
00 100910 RK	PRD-9,600	Residential 9,600 sq. ft.	SFR-Basic
00 102518 RK	PRD-9,600	Residential 9,600 sq. ft.	Single Family Res-Combo
00 101188 RK	R-5	Rural-5 Acre	Single Family Res-Combo
00 106826 RK	R-5	Rural-5 Acre	SFR-Basic
99 113198 RK	R-5	Rural-5 Acre	Single Family Res-Combo
00 103322 RK	PRD SA-1	Suburban Agriculture-1 Acre	SFR-Basic
00 104780 RK	PRD SA-1	Suburban Agriculture-1 Acre	SFR-Basic
00 107829 RK	PRD SA-1	Suburban Agriculture-1 Acre	Single Family Res-Combo
00 107826 RK	PRD SA-1	Suburban Agriculture-1 Acre	SFR-Basic
00 106074 RK	PRD SA-1	Suburban Agriculture-1 Acre	SFR-Basic
00 103321 RK	PRD SA-1	Suburban Agriculture-1 Acre	Single Family Res-Combo
00 107828 RK	PRD SA-1	Suburban Agriculture-1 Acre	Single Family Res-Combo
00 107827 RK	PRD SA-1	Suburban Agriculture-1 Acre	SFR-Basic
00 105055 RK	PRD SA-1	Suburban Agriculture-1 Acre	SFR-Basic
00 104102 RK	PRD SA-1	Suburban Agriculture-1 Acre	Single Family Res-Combo
00 107831 RK	PRD SA-1	Suburban Agriculture-1 Acre	SFR-Basic
00 106655 RK	R-5	Rural-5 Acre	SFR-Basic
00 103820 RK	R-5	Rural-5 Acre	Single Family Res-Combo
00 106656 RK	R-5	Rural-5 Acre	SFR-Basic
00 101959 RK	PRD-9,600	Residential 9,600 sq. ft.	SFR-Basic
00 101958 RK	PRD-9,600	Residential 9,600 sq. ft.	SFR-Basic
00 101961 RK	PRD-9,600	Residential 9,600 sq. ft.	SFR-Basic
00 102156 RK	PRD-9,600	Residential 9,600 sq. ft.	SFR-Basic
00 102159 RK	PRD-9,600	Residential 9,600 sq. ft.	SFR-Basic
00 102160 RK	PRD-9,600	Residential 9,600 sq. ft.	SFR-Basic
00 102158 RK	PRD-9,600	Residential 9,600 sq. ft.	SFR-Basic

Accessory Dwelling Units

Index # - File Name: 1.0022 - Single Family Dwellings Data\_Snohomish County.pdf

00 102157 RK	PRD-9,600	Residential 9,600 sq. ft.	SFR-Basic
00 102243 RK	PRD-9,600	Residential 9,600 sq. ft.	SFR-Basic
00 102244 RK	PRD-9,600	Residential 9,600 sq. ft.	SFR-Basic
00 102242 RK	PRD-9,600	Residential 9,600 sq. ft.	SFR-Basic
00 102367 RK	PRD-9,600	Residential 9,600 sq. ft.	SFR-Basic
00 102369 RK	PRD-9,600	Residential 9,600 sq. ft.	SFR-Basic
00 102368 RK	PRD-9,600	Residential 9,600 sq. ft.	SFR-Basic
00 102624 RK	PRD-9,600	Residential 9,600 sq. ft.	SFR-Basic
00 106060 RK	PRD-9,600	Residential 9,600 sq. ft.	SFR-Basic
00 107425 RK	PRD-9,600	Residential 9,600 sq. ft.	SFR-Basic
00 102867 RK	PRD-9,600	Residential 9,600 sq. ft.	SFR-Basic
00 107288 RK	PRD-9,600	Residential 9,600 sq. ft.	SFR-Basic
00 102869 RK	PRD-9,600	Residential 9,600 sq. ft.	SFR-Basic
00 103227 RK	PRD-9,600	Residential 9,600 sq. ft.	SFR-Basic
00 103226 RK	PRD-9,600	Residential 9,600 sq. ft.	SFR-Basic
00 105671 RK	PRD-9,600	Residential 9,600 sq. ft.	SFR-Basic
99 115846 RK	PRD-9,600	Residential 9,600 sq. ft.	Single Family Res-Combo
99 115845 RK	PRD-9,600	Residential 9,600 sq. ft.	Single Family Res-Combo
99 115847 RK	PRD-9,600	Residential 9,600 sq. ft.	SFR-Basic
00 100567 RK	PRD-9,600	Residential 9,600 sq. ft.	Single Family Res-Combo
00 100571 RK	PRD-9,600	Residential 9,600 sq. ft.	SFR-Basic
00 101253 RK	PRD-9,600	Residential 9,600 sq. ft.	SFR-Basic
00 101473 RK	PRD-9,600	Residential 9,600 sq. ft.	SFR-Basic
00 100572 RK	PRD-9,600	Residential 9,600 sq. ft.	SFR-Basic
00 100566 RK	PRD-9,600	Residential 9,600 sq. ft.	Single Family Res-Combo
00 101254 RK	PRD-9,600	Residential 9,600 sq. ft.	SFR-Basic
00 101469 RK	PRD-9,600	Residential 9,600 sq. ft.	SFR-Basic
00 101255 RK	PRD-9,600	Residential 9,600 sq. ft.	SFR-Basic
00 101466 RK	PRD-9,600	Residential 9,600 sq. ft.	SFR-Basic
00 100819 RK	PRD-9,600	Residential 9,600 sq. ft.	Single Family Res-Combo
00 100573 RK	PRD-9,600	Residential 9,600 sq. ft.	SFR-Basic
00 101470 RK	PRD-9,600	Residential 9,600 sq. ft.	SFR-Basic
00 101257 RK	PRD-9,600	Residential 9,600 sq. ft.	SFR-Basic
00 100477 RK	R-8,400	Residential 8,400 sq. ft.	SFR-Basic
00 103298 RK	PRD-8,400	Residential 8,400 sq. ft.	SFR-Basic
00 105641 RK	R-5	Rural-5 Acre	Single Family Res-Combo
99 116069 RK	R-5	Rural-5 Acre	Single Family Res-Combo
00 103501 RK	R-5	Rural-5 Acre	Single Family Res-Combo
99 112527 MH	R-5	Rural-5 Acre	Single Wide
00 102987 RK	PRD-8,400	Residential 8,400 sq. ft.	SFR-Basic
00 100948 RK	R-5	Rural-5 Acre	Single Family Res-Combo
99 116235 RK	PRD-8,400	Residential 8,400 sq. ft.	Single Family Res-Combo
99 116399 RK	PRD-8,400	Residential 8,400 sq. ft.	SFR-Basic
00 104580 RK	PRD-8,400	Residential 8,400 sq. ft.	SFR-Basic
00 101334 RK	PRD-8,400	Residential 8,400 sq. ft.	SFR-Basic
99 111617 MH	A-10	Agriculture-10 Acre	Single Wide
00 103921 RK	R-5	Rural-5 Acre	Single Family Res-Combo

Accessory Dwelling Units

Index # - File Name: 1.0022 - Single Family Dwellings Data\_Snohomish County.pdf

00 104358 MH	R-5	Rural-5 Acre	Triple Wide
99 115492 RK	R-9,600	Residential 9,600 sq. ft.	SFR-Basic
00 103496 RK	R-9,600	Residential 9,600 sq. ft.	Single Family Res-Combo
00 101537 RK	R-9,600	Residential 9,600 sq. ft.	Single Family Res-Combo
00 102756 RK	R-5	Rural-5 Acre	SFR-Basic
99 111983 RK	R-9,600	Residential 9,600 sq. ft.	SFR-Basic
99 115489 RK	R-9,600	Residential 9,600 sq. ft.	Single Family Res-Combo
00 106634 RK	R-9,600	Residential 9,600 sq. ft.	SFR-Basic
00 104828 RK	R-9,600	Residential 9,600 sq. ft.	SFR-Basic
00 104954 RK	PRD-9,600	Residential 9,600 sq. ft.	Single Family Res-Combo
00 102749 RK	PRD-7,200 : PF	Residential 7,200 sq. ft. : Res	Single Family Res-Combo
00 102673 RK	PRD-9,600	Residential 9,600 sq. ft.	SFR-Basic
00 102674 RK	PRD-9,600	Residential 9,600 sq. ft.	Single Family Res-Combo
00 104399 RK	PRD-9,600	Residential 9,600 sq. ft.	SFR-Basic
00 104404 RK	PRD-9,600	Residential 9,600 sq. ft.	SFR-Basic
00 100722 RK	PRD-9,600	Residential 9,600 sq. ft.	SFR-Basic
99 110155 RK	UC	Urban Center	Duplex-Combo
00 101517 RK	PRD-9,600	Residential 9,600 sq. ft.	Single Family Res-Combo
00 110422 RK	PRD-9,600	Residential 9,600 sq. ft.	SFR-Basic
00 100725 RK	PRD-9,600	Residential 9,600 sq. ft.	SFR-Basic
00 101434 RK	R-5	Rural-5 Acre	Single Family Res-Combo
99 114113 MH	R-5	Rural-5 Acre	Double Wide
00 101802 RK	A-10	Agriculture-10 Acre	Single Family Res-Combo
00 102325 MH	CITY	City	Double Wide
00 105016 MH	R-5	Rural-5 Acre	Double Wide
00 107631 RK	R-5	Rural-5 Acre	Single Family Res-Combo
00 102319 MH	R-5	Rural-5 Acre	Single Wide
99 111837 RK	R-5	Rural-5 Acre	Single Family Res-Combo
99 109981 RK	R-5	Rural-5 Acre	Single Family Res-Combo
00 107037 MH	R-5	Rural-5 Acre	Single Wide
00 102661 RK	R-5	Rural-5 Acre	Single Family Res-Combo
99 113752 RK	R-5	Rural-5 Acre	SFR-Basic
99 109775 RK	R-5	Rural-5 Acre	Single Family Res-Combo
00 102662 RK	R-5	Rural-5 Acre	SFR-Basic
99 113309 RK	R-5	Rural-5 Acre	Single Family Res-Combo
99 110279 RK	RD	Rural Diversification	Single Family Res-Combo
99 105223 MH	F	Forestry	Triple Wide
99 114945 MH	CITY	City	Triple Wide
99 105241 RK	R-5	Rural-5 Acre	Duplex-Combo
00 106549 RK	R-9,600	Residential 9,600 sq. ft.	SFR-Basic
00 106548 RK	R-9,600	Residential 9,600 sq. ft.	Single Family Res-Combo
00 104829 RK	R-9,600	Residential 9,600 sq. ft.	SFR-Basic
00 101515 RK	R-9,600	Residential 9,600 sq. ft.	SFR-Basic
00 104139 RK	R-9,600	Residential 9,600 sq. ft.	Single Family Res-Combo
99 111488 RK	R-9,600	Residential 9,600 sq. ft.	Single Family Res-Combo
00 101514 RK	R-9,600	Residential 9,600 sq. ft.	SFR-Basic
00 103376 RK	R-9,600	Residential 9,600 sq. ft.	Single Family Res-Combo

Accessory Dwelling Units

Index # - File Name: 1.0022 - Single Family Dwellings Data\_Snohomish County.pdf

00 106400 RK	R-9,600	Residential 9,600 sq. ft.	SFR-Basic
00 110254 RK	R-9,600	Residential 9,600 sq. ft.	Single Family Res-Combo
00 109150 RK	R-9,600	Residential 9,600 sq. ft.	Single Family Res-Combo
00 101512 RK	R-9,600	Residential 9,600 sq. ft.	SFR-Basic
00 106373 RK	R-9,600	Residential 9,600 sq. ft.	SFR-Basic
00 101830 RK	R-9,600	Residential 9,600 sq. ft.	Single Family Res-Combo
00 101244 RK	R-9,600	Residential 9,600 sq. ft.	SFR-Basic
00 101832 RK	R-9,600	Residential 9,600 sq. ft.	Single Family Res-Combo
00 101248 RK	R-9,600	Residential 9,600 sq. ft.	SFR-Basic
00 101247 RK	R-9,600	Residential 9,600 sq. ft.	SFR-Basic
00 101246 RK	R-9,600	Residential 9,600 sq. ft.	SFR-Basic
99 112630 RK	R-9,600	Residential 9,600 sq. ft.	SFR-Basic
99 112631 RK	R-9,600	Residential 9,600 sq. ft.	SFR-Basic
00 104117 RK	R-9,600	Residential 9,600 sq. ft.	Single Family Res-Combo
00 104119 RK	R-9,600	Residential 9,600 sq. ft.	Single Family Res-Combo
00 102189 RK	R-9,600	Residential 9,600 sq. ft.	SFR-Basic
00 107345 RK	R-9,600	Residential 9,600 sq. ft.	Single Family Res-Combo
00 107385 RK	R-9,600	Residential 9,600 sq. ft.	SFR-Basic
99 115127 RK	R-9,600	Residential 9,600 sq. ft.	Single Family Res-Combo
99 115128 RK	R-9,600	Residential 9,600 sq. ft.	Single Family Res-Combo
00 103426 RK	R-9,600	Residential 9,600 sq. ft.	Single Family Res-Combo
00 106788 RK	R-9,600	Residential 9,600 sq. ft.	SFR-Basic
00 102190 RK	R-9,600	Residential 9,600 sq. ft.	SFR-Basic
99 116278 RK	A-10	Agriculture-10 Acre	Single Family Res-Combo
00 103295 RK	R-5	Rural-5 Acre	Single Family Res-Combo
99 113963 MH	R-5	Rural-5 Acre	Double Wide
00 103381 RK	PRD-9,600	Residential 9,600 sq. ft.	Single Family Res-Combo
99 111188 RK	R-5	Rural-5 Acre	Single Family Res-Combo
00 103933 RK	R-9,600	Residential 9,600 sq. ft.	SFR-Basic
00 109208 RK	R-5	Rural-5 Acre	Single Family Res-Combo
00 101807 RK	R-5	Rural-5 Acre	Single Family Res-Combo
99 115115 RK	R-5	Rural-5 Acre	Single Family Res-Combo
99 115116 RK	R-5	Rural-5 Acre	Single Family Res-Combo
00 102610 RK	R-5	Rural-5 Acre	Single Family Res-Combo
00 107354 RK	R-5	Rural-5 Acre	SFR-Basic
00 107426 MH	MHP	Mobile Home Park	MH Park-Single Wide
00 107513 MH	R-5	Rural-5 Acre	Triple Wide
00 107774 RK	R-5	Rural-5 Acre	Single Family Res-Combo
00 107791 MH	RD	Rural Diversification	Double Wide
00 108894 RK	PRD-9,600	Residential 9,600 sq. ft.	SFR-Basic
00 103061 RK	PRD-9,600	Residential 9,600 sq. ft.	Single Family Res-Combo
00 108298 RK	PRD-9,600	Residential 9,600 sq. ft.	SFR-Basic
00 103713 RK	PRD-9,600	Residential 9,600 sq. ft.	Single Family Res-Combo
00 109319 RK	PRD-9,600	Residential 9,600 sq. ft.	SFR-Basic
00 109322 RK	PRD-9,600	Residential 9,600 sq. ft.	SFR-Basic
00 108300 RK	PRD-9,600	Residential 9,600 sq. ft.	SFR-Basic
00 103050 RK	PRD-9,600	Residential 9,600 sq. ft.	Single Family Res-Combo

Accessory Dwelling Units

Index # - File Name: 1.0022 - Single Family Dwellings Data\_Snohomish County.pdf

00 110035 RK	PRD-9,600	Residential 9,600 sq. ft.	SFR-Basic
00 110036 RK	PRD-9,600	Residential 9,600 sq. ft.	Single Family Res-Combo
00 110038 RK	PRD-9,600	Residential 9,600 sq. ft.	SFR-Basic
00 107968 RK	R-5	Rural-5 Acre	Single Family Res-Combo
00 107967 RK	R-5	Rural-5 Acre	Single Family Res-Combo
00 110033 RK	PRD-9,600	Residential 9,600 sq. ft.	SFR-Basic
00 108892 RK	PRD-9,600	Residential 9,600 sq. ft.	SFR-Basic
00 108895 RK	PRD-9,600	Residential 9,600 sq. ft.	SFR-Basic
00 108893 RK	PRD-9,600	Residential 9,600 sq. ft.	SFR-Basic
00 108084 MH	R-5	Rural-5 Acre	Double Wide
00 108049 RK	R-5	Rural-5 Acre	SFR-Basic
00 110223 RK	R-5	Rural-5 Acre	SFR-Basic
00 110225 RK	R-5	Rural-5 Acre	SFR-Basic
00 110224 RK	R-5	Rural-5 Acre	SFR-Basic
00 108048 RK	R-5	Rural-5 Acre	SFR-Basic
00 110040 RK	PRD-7,200	Residential 7,200 sq. ft.	SFR-Basic
00 110041 RK	PRD-7,200	Residential 7,200 sq. ft.	SFR-Basic
00 110042 RK	PRD-7,200	Residential 7,200 sq. ft.	SFR-Basic
00 110043 RK	PRD-7,200	Residential 7,200 sq. ft.	SFR-Basic
00 110044 RK	PRD-7,200	Residential 7,200 sq. ft.	SFR-Basic
00 108328 RK	PRD-7,200	Residential 7,200 sq. ft.	SFR-Basic
00 108327 RK	PRD-7,200	Residential 7,200 sq. ft.	SFR-Basic
00 108330 RK	PRD-7,200	Residential 7,200 sq. ft.	SFR-Basic
00 108275 RK	R-5	Rural-5 Acre	Single Family Res-Combo
00 110138 RK	PRD-7,200	Residential 7,200 sq. ft.	Single Family Res-Combo
00 107700 RK	PRD-7,200	Residential 7,200 sq. ft.	Single Family Res-Combo
00 108243 RK	PRD-7,200	Residential 7,200 sq. ft.	Single Family Res-Combo
00 108240 RK	PRD-7,200	Residential 7,200 sq. ft.	Single Family Res-Combo
00 110076 RK	PRD-7,200	Residential 7,200 sq. ft.	SFR-Basic
00 108242 RK	PRD-7,200	Residential 7,200 sq. ft.	Single Family Res-Combo
00 110469 RK	PRD-7,200	Residential 7,200 sq. ft.	SFR-Basic
00 110475 RK	PRD-7,200	Residential 7,200 sq. ft.	SFR-Basic
00 110073 RK	PRD-7,200	Residential 7,200 sq. ft.	SFR-Basic
00 110471 RK	PRD-7,200	Residential 7,200 sq. ft.	SFR-Basic
00 108451 RK	R-5	Rural-5 Acre	Single Family Res-Combo
00 108842 RK	CITY	City	SFR-Basic
00 109255 RK	CITY	City	SFR-Basic
00 108841 RK	CITY	City	SFR-Basic
00 108716 MH	RRT-10	Rural Resource Transition-10	Double Wide
00 108950 RK	PRD-LDMR	Low Density Multiple Reside	SFR-Basic
00 108951 RK	PRD-LDMR	Low Density Multiple Reside	SFR-Basic
00 108641 RK	PRD-LDMR	Low Density Multiple Reside	SFR-Basic
00 108958 RK	PRD-LDMR	Low Density Multiple Reside	SFR-Basic
00 110393 RK	PRD-LDMR	Low Density Multiple Reside	SFR-Basic
00 108960 RK	PRD-LDMR	Low Density Multiple Reside	SFR-Basic
00 110395 RK	PRD-LDMR	Low Density Multiple Reside	SFR-Basic
00 108952 RK	PRD-LDMR	Low Density Multiple Reside	SFR-Basic



Accessory Dwelling Units

Index # - File Name: 1.0022 - Single Family Dwellings Data\_Snohomish County.pdf

00 108953 RK	PRD-LDMR	Low Density Multiple Reside	SFR-Basic
00 108878 RK	PRD-LDMR	Low Density Multiple Reside	Single Family Res-Combo
00 108963 RK	PRD-LDMR	Low Density Multiple Reside	SFR-Basic
00 104557 RK	PRD-LDMR	Low Density Multiple Reside	Single Family Res-Combo
00 108949 RK	PRD-LDMR	Low Density Multiple Reside	Single Family Res-Combo
00 104556 RK	PRD-LDMR	Low Density Multiple Reside	Single Family Res-Combo
00 107867 RK	PRD-LDMR	Low Density Multiple Reside	Single Family Res-Combo
00 108643 RK	PRD-LDMR	Low Density Multiple Reside	SFR-Basic
00 108642 RK	PRD-LDMR	Low Density Multiple Reside	SFR-Basic
00 108954 RK	PRD-LDMR	Low Density Multiple Reside	SFR-Basic
00 110123 RK	PRD-LDMR	Low Density Multiple Reside	Single Family Res-Combo
00 108957 RK	PRD-LDMR	Low Density Multiple Reside	SFR-Basic
00 108956 RK	PRD-LDMR	Low Density Multiple Reside	SFR-Basic
00 108955 RK	PRD-LDMR	Low Density Multiple Reside	SFR-Basic
00 106714 RK	PRD-LDMR	Low Density Multiple Reside	Single Family Res-Combo
00 106715 RK	PRD-LDMR	Low Density Multiple Reside	Single Family Res-Combo
00 108961 RK	PRD-LDMR	Low Density Multiple Reside	SFR-Basic
00 109254 RK	CITY	City	SFR-Basic
00 109259 RK	CITY	City	SFR-Basic
00 109252 RK	CITY	City	SFR-Basic
00 108843 RK	CITY	City	SFR-Basic
00 108753 RK	CITY	City	SFR-Basic
00 108755 RK	CITY	City	SFR-Basic
00 108676 RK	R-5	Rural-5 Acre	Single Family Res-Combo
00 108844 RK	CITY	City	SFR-Basic
00 110658 RK	R-5	Rural-5 Acre	SFR-Basic
00 110659 RK	R-5	Rural-5 Acre	SFR-Basic
00 110696 RK	R-5	Rural-5 Acre	SFR-Basic
00 108940 RK	R-5	Rural-5 Acre	Single Family Res-Combo
00 108942 RK	R-5	Rural-5 Acre	Single Family Res-Combo
00 108944 RK	R-5	Rural-5 Acre	Single Family Res-Combo
00 110762 RK	PRD-7,200	Residential 7,200 sq. ft.	SFR-Basic
00 110332 RK	PRD-7,200	Residential 7,200 sq. ft.	SFR-Basic
00 110334 RK	PRD-7,200	Residential 7,200 sq. ft.	SFR-Basic
00 110335 RK	PRD-7,200	Residential 7,200 sq. ft.	SFR-Basic
00 109686 RK	CITY	City	Single Family Res-Combo
00 109736 RK	CITY	City	Single Family Res-Combo
00 109726 RK	CITY	City	Single Family Res-Combo
00 109692 RK	CITY	City	Single Family Res-Combo
00 109671 RK	CITY	City	Single Family Res-Combo
00 109679 RK	CITY	City	Single Family Res-Combo
00 109674 RK	CITY	City	Single Family Res-Combo
00 109678 RK	CITY	City	Single Family Res-Combo
00 109677 RK	CITY	City	Single Family Res-Combo
00 109977 RK	R-9,600	Residential 9,600 sq. ft.	SFR-Basic
00 109438 RK	R-9,600	Residential 9,600 sq. ft.	SFR-Basic
00 109663 RK	R-9,600	Residential 9,600 sq. ft.	SFR-Basic

Accessory Dwelling Units

Index # - File Name: 1.0022 - Single Family Dwellings Data\_Snohomish County.pdf

00 107889 RK	PRD-7,200	Residential 7,200 sq. ft.	Single Family Res-Combo
00 107834 RK	PRD-7,200	Residential 7,200 sq. ft.	Single Family Res-Combo
00 109572 RK	PRD-7,200	Residential 7,200 sq. ft.	SFR-Basic
00 109573 RK	PRD-7,200	Residential 7,200 sq. ft.	SFR-Basic
00 109568 RK	PRD-7,200	Residential 7,200 sq. ft.	SFR-Basic
00 109569 RK	PRD-7,200	Residential 7,200 sq. ft.	SFR-Basic
00 109570 RK	PRD-7,200	Residential 7,200 sq. ft.	SFR-Basic
00 109574 RK	PRD-7,200	Residential 7,200 sq. ft.	SFR-Basic
00 108098 RK	PRD-7,200	Residential 7,200 sq. ft.	Single Family Res-Combo
00 108096 RK	PRD-7,200	Residential 7,200 sq. ft.	Single Family Res-Combo
00 110068 RK	PRD-7,200	Residential 7,200 sq. ft.	SFR-Basic
00 110069 RK	PRD-7,200	Residential 7,200 sq. ft.	SFR-Basic
00 109947 RK	R-7,200	Residential 7,200 sq. ft.	SFR-Basic
00 110011 RK	R-7,200	Residential 7,200 sq. ft.	SFR-Basic
00 110012 RK	R-7,200	Residential 7,200 sq. ft.	SFR-Basic
00 109954 RK	R-7,200	Residential 7,200 sq. ft.	SFR-Basic
00 109951 RK	R-7,200	Residential 7,200 sq. ft.	SFR-Basic
00 109864 RK	R-7,200	Residential 7,200 sq. ft.	SFR-Basic
00 109948 RK	R-7,200	Residential 7,200 sq. ft.	SFR-Basic
00 109858 RK	R-7,200	Residential 7,200 sq. ft.	SFR-Basic
00 109926 RK	RRT-10	Rural Resource Transition-10	Single Family Res-Combo
00 110836 RK	PRD-7,200	Residential 7,200 sq. ft.	SFR-Basic
99 112832 RK	A-10 : R-5	Agriculture-10 Acre : Rural-5	Single Family Res-Combo
00 104542 RK	R-7,200	Residential 7,200 sq. ft.	SFR-Basic
99 115568 RK	R-7,200	Residential 7,200 sq. ft.	SFR-Basic
99 115419 RK	R-7,200	Residential 7,200 sq. ft.	SFR-Basic
99 115705 RK	R-7,200	Residential 7,200 sq. ft.	SFR-Basic
99 113319 RK	R-5	Rural-5 Acre	Single Family Res-Combo
00 101778 RK	R-5	Rural-5 Acre	Single Family Res-Combo
00 105707 RK	R-7,200	Residential 7,200 sq. ft.	SFR-Basic
99 115567 RK	R-7,200	Residential 7,200 sq. ft.	SFR-Basic
00 102597 RK	R-7,200	Residential 7,200 sq. ft.	SFR-Basic
00 103739 RK	R-7,200	Residential 7,200 sq. ft.	SFR-Basic
00 102256 RK	R-7,200	Residential 7,200 sq. ft.	SFR-Basic
00 101719 RK	R-7,200	Residential 7,200 sq. ft.	SFR-Basic
00 106251 RK	R-7,200	Residential 7,200 sq. ft.	SFR-Basic
00 103261 RK	R-7,200	Residential 7,200 sq. ft.	SFR-Basic
00 104539 RK	R-7,200	Residential 7,200 sq. ft.	SFR-Basic
00 101933 RK	R-7,200	Residential 7,200 sq. ft.	SFR-Basic
00 101720 RK	R-7,200	Residential 7,200 sq. ft.	SFR-Basic
00 104540 RK	R-7,200	Residential 7,200 sq. ft.	SFR-Basic
00 105708 RK	R-7,200	Residential 7,200 sq. ft.	SFR-Basic
00 101774 RK	R-5	Rural-5 Acre	Single Family Res-Combo
00 107983 RK	PRD-9,600	Residential 9,600 sq. ft.	SFR-Basic
99 116041 RK	R-7,200	Residential 7,200 sq. ft.	SFR-Basic
00 104536 RK	R-7,200	Residential 7,200 sq. ft.	SFR-Basic
99 115871 RK	R-7,200	Residential 7,200 sq. ft.	SFR-Basic

Accessory Dwelling Units

Index # - File Name: 1.0022 - Single Family Dwellings Data\_Snohomish County.pdf

00 101718 RK	R-7,200	Residential 7,200 sq. ft.	SFR-Basic
99 116168 RK	R-7,200	Residential 7,200 sq. ft.	SFR-Basic
00 101935 RK	R-7,200	Residential 7,200 sq. ft.	SFR-Basic
00 103262 RK	R-7,200	Residential 7,200 sq. ft.	SFR-Basic
00 104537 RK	R-7,200	Residential 7,200 sq. ft.	SFR-Basic
00 105703 RK	R-7,200	Residential 7,200 sq. ft.	SFR-Basic
00 104327 RK	R-7,200	Residential 7,200 sq. ft.	SFR-Basic
00 103263 RK	R-7,200	Residential 7,200 sq. ft.	SFR-Basic
00 105704 RK	R-7,200	Residential 7,200 sq. ft.	SFR-Basic
99 115872 RK	R-7,200	Residential 7,200 sq. ft.	SFR-Basic
99 115870 RK	R-7,200	Residential 7,200 sq. ft.	SFR-Basic
00 105706 RK	R-7,200	Residential 7,200 sq. ft.	SFR-Basic
99 116091 RK	R-9,600	Residential 9,600 sq. ft.	Single Family Res-Combo
00 105702 RK	R-9,600	Residential 9,600 sq. ft.	Single Family Res-Combo
00 106262 RK	R-9,600	Residential 9,600 sq. ft.	Single Family Res-Combo
00 103330 RK	R-9,600	Residential 9,600 sq. ft.	Single Family Res-Combo
00 101382 RK	R-9,600	Residential 9,600 sq. ft.	SFR-Basic
00 103913 RK	R-9,600	Residential 9,600 sq. ft.	Single Family Res-Combo
99 112203 RK	R-9,600	Residential 9,600 sq. ft.	SFR-Basic
00 100970 RK	PRD-9,600	Residential 9,600 sq. ft.	SFR-Basic
99 116217 RK	CITY	City	SFR-Basic
99 116218 RK	CITY	City	SFR-Basic
99 114972 RK	RC	Rural Conservation	SFR-Basic
99 114974 RK	RC	Rural Conservation	Single Family Res-Combo
00 102558 RK	RC	Rural Conservation	SFR-Basic
00 103209 RK	RC	Rural Conservation	SFR-Basic
00 103210 RK	RC	Rural Conservation	SFR-Basic
00 105330 RK	RC	Rural Conservation	SFR-Basic
00 103211 RK	RC	Rural Conservation	SFR-Basic
00 109256 RK	RC	Rural Conservation	SFR-Basic
00 105334 RK	RC	Rural Conservation	SFR-Basic
00 108733 RK	RC	Rural Conservation	Single Family Res-Combo
00 109164 RK	RC	Rural Conservation	SFR-Basic
00 108974 RK	RC	Rural Conservation	SFR-Basic
00 108971 RK	RC	Rural Conservation	SFR-Basic
00 109163 RK	RC	Rural Conservation	SFR-Basic
00 109162 RK	RC	Rural Conservation	SFR-Basic
00 109161 RK	RC	Rural Conservation	SFR-Basic
99 114663 RK	RC	Rural Conservation	SFR-Basic
00 105342 RK	RC	Rural Conservation	SFR-Basic
00 108972 RK	RC	Rural Conservation	SFR-Basic
00 103207 RK	RC	Rural Conservation	SFR-Basic
00 105338 RK	RC	Rural Conservation	SFR-Basic
00 105336 RK	RC	Rural Conservation	SFR-Basic
00 103876 RK	RC	Rural Conservation	SFR-Basic
00 103053 RK	RC	Rural Conservation	SFR-Basic
99 110879 RK	RC	Rural Conservation	Single Family Res-Combo

Accessory Dwelling Units

Index # - File Name: 1.0022 - Single Family Dwellings Data\_Snohomish County.pdf

99 111764 RK	RC	Rural Conservation	Single Family Res-Combo
00 100986 RK	RC	Rural Conservation	Single Family Res-Combo
00 103195 RK	R-5	Rural-5 Acre	Single Family Res-Combo
00 100852 RK	R-5	Rural-5 Acre	Single Family Res-Combo
00 108311 RK	R-5	Rural-5 Acre	Single Family Res-Combo
00 107712 RK	R-5	Rural-5 Acre	SFR-Basic
00 107713 RK	R-5	Rural-5 Acre	SFR-Basic
99 115722 RK	R-5	Rural-5 Acre	Single Family Res-Combo
00 109334 MH	CITY	City	Triple Wide
00 107465 MH	CITY	City	Triple Wide
00 102783 RK	R-5	Rural-5 Acre	SFR-Basic
00 102758 RK	R-5	Rural-5 Acre	Single Family Res-Combo
00 101918 RK	R-5	Rural-5 Acre	Single Family Res-Combo
00 103348 RK	R-5	Rural-5 Acre	Single Family Res-Combo
00 101983 RK	R-5	Rural-5 Acre	Single Family Res-Combo
00 108052 RK	R-5	Rural-5 Acre	SFR-Basic
00 101274 RK	R-5	Rural-5 Acre	Single Family Res-Combo
00 101380 RK	R-5	Rural-5 Acre	Single Family Res-Combo
00 103881 RK	R-5	Rural-5 Acre	Single Family Res-Combo
00 105611 RK	R-5	Rural-5 Acre	Single Family Res-Combo
00 107295 RK	R-5	Rural-5 Acre	Single Family Res-Combo
00 105580 RK	R-5	Rural-5 Acre	SFR-Basic
00 101651 RK	R-5	Rural-5 Acre	Single Family Res-Combo
00 107122 RK	R-5	Rural-5 Acre	SFR-Basic
00 109795 RK	R-5	Rural-5 Acre	SFR-Basic
00 102875 RK	R-5	Rural-5 Acre	SFR-Basic
00 103327 RK	R-5	Rural-5 Acre	Single Family Res-Combo
00 102622 RK	R-5	Rural-5 Acre	Single Family Res-Combo
00 101034 RK	R-5	Rural-5 Acre	Single Family Res-Combo
00 105691 RK	R-5	Rural-5 Acre	Single Family Res-Combo
00 110031 RK	R-5	Rural-5 Acre	SFR-Basic
00 103831 MH	R-5	Rural-5 Acre	Double Wide
99 115856 RK	R-5	Rural-5 Acre	Single Family Res-Combo
99 113979 MH	F	Forestry	Triple Wide
00 106244 RK	R-5	Rural-5 Acre	Single Family Res-Combo
99 113290 RK	R-5	Rural-5 Acre	SFR-Basic
00 104106 RK	R-5	Rural-5 Acre	Single Family Res-Combo
00 109036 RK	R-5	Rural-5 Acre	SFR-Basic
00 100928 RK	R-5	Rural-5 Acre	SFR-Basic
99 115017 RK	R-5	Rural-5 Acre	SFR-Basic
00 107786 RK	R-5	Rural-5 Acre	SFR-Basic
00 107787 RK	R-5	Rural-5 Acre	SFR-Basic
00 107785 RK	R-5	Rural-5 Acre	SFR-Basic
00 109035 RK	R-5	Rural-5 Acre	SFR-Basic
00 109119 RK	R-5	Rural-5 Acre	SFR-Basic
00 109122 RK	R-5	Rural-5 Acre	SFR-Basic
00 105711 RK	R-5	Rural-5 Acre	SFR-Basic

Accessory Dwelling Units

Index # - File Name: 1.0022 - Single Family Dwellings Data\_Snohomish County.pdf

00 105712 RK	R-5	Rural-5 Acre	SFR-Basic
00 105713 RK	R-5	Rural-5 Acre	SFR-Basic
00 105714 RK	R-5	Rural-5 Acre	SFR-Basic
00 101786 RK	R-5	Rural-5 Acre	SFR-Basic
00 103264 RK	R-5	Rural-5 Acre	SFR-Basic
00 107300 RK	R-5	Rural-5 Acre	SFR-Basic
00 104039 RK	R-5	Rural-5 Acre	SFR-Basic
00 101721 RK	R-5	Rural-5 Acre	SFR-Basic
00 102257 RK	R-5	Rural-5 Acre	SFR-Basic
00 101723 RK	R-5	Rural-5 Acre	SFR-Basic
00 104546 RK	R-5	Rural-5 Acre	SFR-Basic
00 101724 RK	R-5	Rural-5 Acre	SFR-Basic
00 107299 RK	R-5	Rural-5 Acre	SFR-Basic
00 101785 RK	R-5	Rural-5 Acre	SFR-Basic
00 105718 RK	R-5	Rural-5 Acre	SFR-Basic
00 105715 RK	R-5	Rural-5 Acre	SFR-Basic
00 102258 RK	R-5	Rural-5 Acre	SFR-Basic
00 104544 RK	R-5	Rural-5 Acre	SFR-Basic
00 104543 RK	R-5	Rural-5 Acre	SFR-Basic
99 115041 RK	R-5	Rural-5 Acre	Single Family Res-Combo
99 115287 RK	R-5	Rural-5 Acre	Single Family Res-Combo
99 115395 MH	R-5	Rural-5 Acre	Double Wide
00 103738 RK	R-7,200	Residential 7,200 sq. ft.	SFR-Basic
00 105705 RK	R-7,200	Residential 7,200 sq. ft.	SFR-Basic
00 105709 RK	R-7,200	Residential 7,200 sq. ft.	SFR-Basic
99 116174 RK	R-7,200	Residential 7,200 sq. ft.	SFR-Basic
00 101932 RK	R-7,200	Residential 7,200 sq. ft.	SFR-Basic
99 116175 RK	R-7,200	Residential 7,200 sq. ft.	SFR-Basic
99 115678 RK	R-5	Rural-5 Acre	SFR-Basic
00 105992 RK	PRD-9,600	Residential 9,600 sq. ft.	SFR-Basic
00 105994 RK	PRD-9,600	Residential 9,600 sq. ft.	SFR-Basic
00 100588 RK	R-7,200	Residential 7,200 sq. ft.	Single Family Res-Combo
00 105728 RK	R-5	Rural-5 Acre	Single Family Res-Combo
99 111384 RK	R-5	Rural-5 Acre	Single Family Res-Combo
99 103449 RK	R-5	Rural-5 Acre	Single Family Res-Combo
99 100446 RK	R-5	Rural-5 Acre	Single Family Res-Combo
99 111701 RK	PRD-9,600	Residential 9,600 sq. ft.	SFR-Basic
00 101413 RK	R-5	Rural-5 Acre	Single Family Res-Combo
00 101915 RK	R-5	Rural-5 Acre	Single Family Res-Combo
00 101790 RK	R-5	Rural-5 Acre	Single Family Res-Combo
00 101996 RK	R-5	Rural-5 Acre	Single Family Res-Combo
00 109415 RK	R-5	Rural-5 Acre	SFR-Basic
00 101995 RK	R-5	Rural-5 Acre	SFR-Basic
00 104125 RK	PRD-9,600	Residential 9,600 sq. ft.	SFR-Basic
00 105876 RK	PRD-9,600	Residential 9,600 sq. ft.	SFR-Basic
00 102886 RK	PRD-9,600	Residential 9,600 sq. ft.	SFR-Basic
00 103942 RK	PRD-9,600	Residential 9,600 sq. ft.	Single Family Res-Combo

Accessory Dwelling Units

Index # - File Name: 1.0022 - Single Family Dwellings Data\_Snohomish County.pdf

00 105148 RK	PRD-9,600	Residential 9,600 sq. ft.	SFR-Basic
00 104484 RK	PRD-9,600	Residential 9,600 sq. ft.	SFR-Basic
00 101780 RK	PRD-9,600	Residential 9,600 sq. ft.	SFR-Basic
00 103691 RK	PRD-9,600	Residential 9,600 sq. ft.	SFR-Basic
00 109967 RK	PRD-9,600	Residential 9,600 sq. ft.	SFR-Basic
00 100890 RK	PRD-9,600	Residential 9,600 sq. ft.	Single Family Res-Combo
00 104123 RK	PRD-9,600	Residential 9,600 sq. ft.	SFR-Basic
00 101126 RK	PRD-9,600	Residential 9,600 sq. ft.	SFR-Basic
00 100968 RK	PRD-9,600	Residential 9,600 sq. ft.	SFR-Basic
00 100965 RK	PRD-9,600	Residential 9,600 sq. ft.	SFR-Basic
00 100969 RK	PRD-9,600	Residential 9,600 sq. ft.	SFR-Basic
00 110369 RK	PRD-9,600	Residential 9,600 sq. ft.	SFR-Basic
00 107980 RK	PRD-9,600	Residential 9,600 sq. ft.	SFR-Basic
00 108372 RK	PRD-9,600	Residential 9,600 sq. ft.	SFR-Basic
00 107858 RK	PRD-9,600	Residential 9,600 sq. ft.	SFR-Basic
00 108373 RK	PRD-9,600	Residential 9,600 sq. ft.	SFR-Basic
00 106121 RK	PRD-9,600	Residential 9,600 sq. ft.	Single Family Res-Combo
00 108374 RK	PRD-9,600	Residential 9,600 sq. ft.	Single Family Res-Combo
00 104485 RK	PRD-9,600	Residential 9,600 sq. ft.	SFR-Basic
00 106667 RK	PRD-9,600	Residential 9,600 sq. ft.	SFR-Basic
00 110227 RK	PRD-9,600	Residential 9,600 sq. ft.	Single Family Res-Combo
00 100545 RK	PRD-9,600	Residential 9,600 sq. ft.	SFR-Basic
00 104291 RK	PRD-9,600	Residential 9,600 sq. ft.	SFR-Basic
00 100547 RK	PRD-9,600	Residential 9,600 sq. ft.	SFR-Basic
00 100546 RK	PRD-9,600	Residential 9,600 sq. ft.	SFR-Basic
00 109966 RK	PRD-9,600	Residential 9,600 sq. ft.	SFR-Basic
00 102406 RK	PRD-9,600	Residential 9,600 sq. ft.	SFR-Basic
00 100543 RK	PRD-9,600	Residential 9,600 sq. ft.	SFR-Basic
00 103056 RK	PRD-9,600	Residential 9,600 sq. ft.	SFR-Basic
00 103690 RK	PRD-9,600	Residential 9,600 sq. ft.	SFR-Basic
00 104494 RK	PRD-9,600	Residential 9,600 sq. ft.	SFR-Basic
00 105567 RK	PRD-9,600	Residential 9,600 sq. ft.	SFR-Basic
00 102226 RK	PRD-9,600	Residential 9,600 sq. ft.	Single Family Res-Combo
00 107808 RK	PRD-9,600	Residential 9,600 sq. ft.	SFR-Basic
00 101063 RK	PRD-9,600	Residential 9,600 sq. ft.	SFR-Basic
00 105566 RK	PRD-9,600	Residential 9,600 sq. ft.	SFR-Basic
99 114868 RK	PRD-9,600	Residential 9,600 sq. ft.	SFR-Basic
00 107987 RK	PRD-9,600	Residential 9,600 sq. ft.	Single Family Res-Combo
00 101127 RK	PRD-9,600	Residential 9,600 sq. ft.	SFR-Basic
99 116516 RK	PRD-9,600	Residential 9,600 sq. ft.	SFR-Basic
00 106110 RK	PRD-9,600	Residential 9,600 sq. ft.	Single Family Res-Combo
00 106109 RK	PRD-9,600	Residential 9,600 sq. ft.	SFR-Basic
00 101065 RK	PRD-9,600	Residential 9,600 sq. ft.	SFR-Basic
00 101059 RK	PRD-9,600	Residential 9,600 sq. ft.	Single Family Res-Combo
99 112454 RK	PRD-9,600	Residential 9,600 sq. ft.	Single Family Res-Combo
00 101310 RK	PRD-9,600	Residential 9,600 sq. ft.	Single Family Res-Combo
00 101308 RK	PRD-9,600	Residential 9,600 sq. ft.	SFR-Basic

Accessory Dwelling Units

Index # - File Name: 1.0022 - Single Family Dwellings Data\_Snohomish County.pdf

00 101312 RK	PRD-9,600	Residential 9,600 sq. ft.	Single Family Res-Combo
00 101309 RK	PRD-9,600	Residential 9,600 sq. ft.	SFR-Basic
00 101226 RK	PRD-9,600	Residential 9,600 sq. ft.	SFR-Basic
00 101227 RK	PRD-9,600	Residential 9,600 sq. ft.	Single Family Res-Combo
99 115250 RK	PRD-9,600	Residential 9,600 sq. ft.	SFR-Basic
00 107651 RK	R-5	Rural-5 Acre	Single Family Res-Combo
00 105684 RK	R-5	Rural-5 Acre	Single Family Res-Combo
00 102425 RK	R-5	Rural-5 Acre	Single Family Res-Combo
00 101740 RK	R-5	Rural-5 Acre	Single Family Res-Combo
00 104442 RK	R-5	Rural-5 Acre	Single Family Res-Combo
00 102919 RK	R-5	Rural-5 Acre	Single Family Res-Combo
00 102137 RK	R-5	Rural-5 Acre	SFR-Basic
00 104433 RK	R-5	Rural-5 Acre	Single Family Res-Combo
00 105017 RK	R-5	Rural-5 Acre	SFR-Basic
00 102737 RK	R-5	Rural-5 Acre	Single Family Res-Combo
00 102989 RK	R-5	Rural-5 Acre	Single Family Res-Combo
00 107845 RK	PRD SA-1	Suburban Agriculture-1 Acre	SFR-Basic
00 107841 RK	PRD SA-1	Suburban Agriculture-1 Acre	SFR-Basic
98 110322 RK	R-5	Rural-5 Acre	Single Family Res-Combo
99 105360 RK	R-5	Rural-5 Acre	Single Family Res-Combo
99 114327 RK	R-5	Rural-5 Acre	Single Family Res-Combo
00 109297 RK	R-5	Rural-5 Acre	Single Family Res-Combo
00 110142 RK	PRD SA-1	Suburban Agriculture-1 Acre	SFR-Basic
99 114897 RK	PRD SA-1	Suburban Agriculture-1 Acre	SFR-Basic
00 103452 RK	PRD-9,600	Residential 9,600 sq. ft.	SFR-Basic
00 102013 RK	R-5	Rural-5 Acre	Single Family Res-Combo
99 114181 RK	R-5	Rural-5 Acre	Single Family Res-Combo
99 114057 RK	R-5	Rural-5 Acre	Single Family Res-Combo
00 101944 RK	R-5	Rural-5 Acre	Single Family Res-Combo
98 116991 RK	R-5	Rural-5 Acre	SFR-Basic
00 104167 RK	PRD-9,600	Residential 9,600 sq. ft.	Single Family Res-Combo
00 101947 RK	PRD-9,600	Residential 9,600 sq. ft.	Single Family Res-Combo
00 105013 MH	CITY	City	MH Park-Double Wide
00 105491 MH	CITY	City	MH Park-Double Wide
00 102119 MH	CITY	City	MH Park-Double Wide
00 101605 MH	CITY	City	MH Park-Double Wide
00 102510 MH	CITY	City	MH Park-Double Wide
00 103054 MH	CITY	City	MH Park-Double Wide
00 103029 MH	CITY	City	MH Park-Double Wide
00 104007 MH	CITY	City	MH Park-Double Wide
00 103798 RK	PRD-9,600	Residential 9,600 sq. ft.	Single Family Res-Combo
00 102426 RK	PRD-9,600	Residential 9,600 sq. ft.	Single Family Res-Combo
00 104746 RK	PRD-9,600	Residential 9,600 sq. ft.	SFR-Basic
00 107082 RK	PRD-9,600	Residential 9,600 sq. ft.	SFR-Basic
00 107824 RK	PRD-9,600	Residential 9,600 sq. ft.	Single Family Res-Combo
00 103576 RK	PRD-9,600	Residential 9,600 sq. ft.	SFR-Basic
00 105523 RK	PRD-9,600	Residential 9,600 sq. ft.	SFR-Basic

Accessory Dwelling Units

Index # - File Name: 1.0022 - Single Family Dwellings Data\_Snohomish County.pdf

00 100850 RK	PRD-9,600	Residential 9,600 sq. ft.	SFR-Basic
00 100848 RK	PRD-9,600	Residential 9,600 sq. ft.	SFR-Basic
99 115712 RK	PRD-9,600	Residential 9,600 sq. ft.	Single Family Res-Combo
00 104170 RK	PRD-9,600	Residential 9,600 sq. ft.	Single Family Res-Combo
00 101993 RK	PRD-9,600	Residential 9,600 sq. ft.	SFR-Basic
00 100835 RK	PRD-9,600	Residential 9,600 sq. ft.	Single Family Res-Combo
00 101029 MH	CITY	City	MH Park-Double Wide
00 101311 MH	CITY	City	MH Park-Double Wide
00 101940 MH	CITY	City	MH Park-Double Wide
00 100490 MH	CITY	City	Double Wide
00 103953 MH	CITY	City	MH Park-Triple Wide
00 105603 MH	CITY	City	Triple Wide
00 104764 MH	CITY	City	MH Park-Double Wide
00 103363 MH	CITY	City	MH Park-Double Wide
00 101952 MH	CITY	City	MH Park-Double Wide
00 104860 MH	CITY	City	MH Park-Double Wide
00 102180 MH	CITY	City	MH Park-Double Wide
00 101752 RK	PRD-9,600	Residential 9,600 sq. ft.	SFR-Basic
00 104488 RK	PRD-9,600	Residential 9,600 sq. ft.	Single Family Res-Combo
00 103075 RK	PRD-9,600	Residential 9,600 sq. ft.	SFR-Basic
00 105520 RK	PRD-9,600	Residential 9,600 sq. ft.	SFR-Basic
00 101753 RK	PRD-9,600	Residential 9,600 sq. ft.	SFR-Basic
00 103950 MH	CITY	City	MH Park-Triple Wide
00 101751 RK	PRD-9,600	Residential 9,600 sq. ft.	SFR-Basic
99 115759 RK	PRD-9,600	Residential 9,600 sq. ft.	Single Family Res-Combo
99 113103 RK	R-5	Rural-5 Acre	Single Family Res-Combo
00 101411 RK	R-7,200	Residential 7,200 sq. ft.	SFR-Basic
00 103509 RK	R-7,200	Residential 7,200 sq. ft.	SFR-Basic
00 101275 RK	R-20,000	Residential 20,000 sq. ft.	Single Family Res-Combo
00 104344 MH	R-5	Rural-5 Acre	Triple Wide
00 103469 RK	R-7,200	Residential 7,200 sq. ft.	SFR-Basic
00 102229 RK	R-5	Rural-5 Acre	Single Family Res-Combo
99 101466 RK	R-5	Rural-5 Acre	Single Family Res-Combo
00 100788 RK	R-5	Rural-5 Acre	Single Family Res-Combo
00 100787 RK	R-5	Rural-5 Acre	Single Family Res-Combo
00 103470 RK	R-7,200	Residential 7,200 sq. ft.	SFR-Basic
99 113420 MH	F	Forestry	Double Wide
00 104287 RK	R-7,200	Residential 7,200 sq. ft.	SFR-Basic
99 112896 RK	R-5	Rural-5 Acre	Single Family Res-Combo
00 100601 RK	R-5	Rural-5 Acre	SFR-Basic
00 100603 RK	R-5	Rural-5 Acre	Single Family Res-Combo
00 104460 RK	R-5	Rural-5 Acre	Single Family Res-Combo
00 100863 RK	R-5	Rural-5 Acre	Single Family Res-Combo
99 113984 RK	R-5	Rural-5 Acre	SFR-Basic
99 113991 RK	R-5	Rural-5 Acre	Single Family Res-Combo
99 109406 RK	R-5	Rural-5 Acre	Single Family Res-Combo
99 109403 RK	R-5	Rural-5 Acre	Single Family Res-Combo



Accessory Dwelling Units

Index # - File Name: 1.0022 - Single Family Dwellings Data\_Snohomish County.pdf

99 110801 RK	R-5	Rural-5 Acre	Single Family Res-Combo
00 105695 RK	R-5	Rural-5 Acre	Single Family Res-Combo
99 112847 RK	R-5	Rural-5 Acre	Single Family Res-Combo
00 101717 RK	R-5	Rural-5 Acre	Single Family Res-Combo
98 108037 RK	R-5	Rural-5 Acre	Single Family Res-Combo
99 101813 RK	R-5	Rural-5 Acre	Single Family Res-Combo
00 108229 MH	R-5	Rural-5 Acre	Double Wide
99 114149 RK	R-7,200	Residential 7,200 sq. ft.	Single Family Res-Combo
98 109031 MH	R-5	Rural-5 Acre	Triple Wide
00 102658 MH	R-5	Rural-5 Acre	Double Wide
98 109335 MH	R-5	Rural-5 Acre	Double Wide
99 113101 RK	PRD-9,600	Residential 9,600 sq. ft.	SFR-Basic
98 100372 000 01 RK	R-5	Rural-5 Acre	Single Family Res-Combo
00 107623 RK	PRD-7,200	Residential 7,200 sq. ft.	Single Family Res-Combo
00 104068 RK	R-5	Rural-5 Acre	Single Family Res-Combo
00 107719 RK	R-8,400	Residential 8,400 sq. ft.	SFR-Basic
00 108886 RK	R-7,200	Residential 7,200 sq. ft.	SFR-Basic
00 103382 RK	R-5	Rural-5 Acre	Single Family Res-Combo
00 102251 RK	R-5	Rural-5 Acre	Single Family Res-Combo
00 101222 RK	R-5	Rural-5 Acre	Single Family Res-Combo
99 114386 RK	RD	Rural Diversification	Single Family Res-Combo
99 114190 RK	R-5	Rural-5 Acre	Single Family Res-Combo
00 104332 RK	R-5	Rural-5 Acre	Single Family Res-Combo
00 105971 RK	R-5	Rural-5 Acre	Single Family Res-Combo
99 116234 RK	R-5	Rural-5 Acre	Single Family Res-Combo
00 106009 RK	R-5	Rural-5 Acre	Single Family Res-Combo
00 102204 RK	R-5	Rural-5 Acre	Single Family Res-Combo
00 102125 RK	R-5	Rural-5 Acre	Single Family Res-Combo
00 101238 RK	R-5	Rural-5 Acre	Single Family Res-Combo
00 108623 RK	CITY	City	Single Family Res-Combo
98 101087 RK	R-5	Rural-5 Acre	Single Family Res-Combo
98 104130 RK	PRD SA-1	Suburban Agriculture-1 Acre	Single Family Res-Combo
99 104746 RK	R-5	Rural-5 Acre	Single Family Res-Combo
99 111682 RK	R-5	Rural-5 Acre	Single Family Res-Combo
98 106567 RK	PRD SA-1	Suburban Agriculture-1 Acre	Single Family Res-Combo
00 100480 RK	PRD SA-1	Suburban Agriculture-1 Acre	Single Family Res-Combo
00 104560 RK	R-5	Rural-5 Acre	Single Family Res-Combo
00 103442 RK	R-5	Rural-5 Acre	Single Family Res-Combo
98 103645 000 01 RK	R-5	Rural-5 Acre	Single Family Res-Combo
99 115551 RK	PRD SA-1	Suburban Agriculture-1 Acre	Single Family Res-Combo
00 107870 RK	PRD SA-1	Suburban Agriculture-1 Acre	SFR-Basic
98 104923 000 01 MH	R-5	Rural-5 Acre	Single Wide
98 108643 000 01 RK	R-5	Rural-5 Acre	Single Family Res-Combo
00 101108 RK	R-5	Rural-5 Acre	Single Family Res-Combo
98 106287 RK	R-5	Rural-5 Acre	Single Family Res-Combo
00 101163 RK	F	Forestry	Single Family Res-Combo
00 105018 RK	R-5	Rural-5 Acre	Single Family Res-Combo

Accessory Dwelling Units

Index # - File Name: 1.0022 - Single Family Dwellings Data\_Snohomish County.pdf

00 100800 RK	R-5	Rural-5 Acre	Single Family Res-Combo
99 115850 MH	F	Forestry	Triple Wide
00 103619 RK	R-5	Rural-5 Acre	Single Family Res-Combo
00 105157 RK	R-5	Rural-5 Acre	Single Family Res-Combo
00 101737 RK	RRT-10	Rural Resource Transition-10	Single Family Res-Combo
99 115327 RK	RRT-10	Rural Resource Transition-10	Single Family Res-Combo
00 101616 RK	RRT-10	Rural Resource Transition-10	Single Family Res-Combo
00 108210 MH	R-5	Rural-5 Acre	Double Wide
99 104192 RK	R-5	Rural-5 Acre	Single Family Res-Combo
99 110344 RK	R-5	Rural-5 Acre	Single Family Res-Combo
00 109086 RK	R-5	Rural-5 Acre	Accessory Apt Detached-Combo
98 106852 000 01 RK	R-5	Rural-5 Acre	Single Family Res-Combo
99 112523 RK	R-5	Rural-5 Acre	Single Family Res-Combo
00 106217 RK	RD	Rural Diversification	Single Family Res-Combo
98 106979 000 01 RK	R-5	Rural-5 Acre	Single Family Res-Combo
00 109989 RK	PRD-LDMR	Low Density Multiple Reside	SFR-Basic
00 109987 RK	PRD-LDMR	Low Density Multiple Reside	SFR-Basic
97 107360 000 01 MH	RD	Rural Diversification	Single Wide
98 105135 000 01 RK	R-5	Rural-5 Acre	Single Family Res-Combo
00 103137 RK	R-5	Rural-5 Acre	Single Family Res-Combo
00 100816 RK	R-5	Rural-5 Acre	Single Family Res-Combo
00 101161 RK	R-5	Rural-5 Acre	Single Family Res-Combo
00 101661 RK	R-5	Rural-5 Acre	Single Family Res-Combo
00 105042 MH	R-5	Rural-5 Acre	Double Wide
00 103260 RK	R-5	Rural-5 Acre	Single Family Res-Combo
00 107314 RK	R-5	Rural-5 Acre	Single Family Res-Combo
00 107693 RK	R-5	Rural-5 Acre	Single Family Res-Combo
00 105270 RK	R-5	Rural-5 Acre	Single Family Res-Combo
00 105353 RK	R-5	Rural-5 Acre	Single Family Res-Combo
00 104932 RK	R-5	Rural-5 Acre	Single Family Res-Combo
00 103812 RK	R-7,200	Residential 7,200 sq. ft.	Single Family Res-Combo
00 107144 RK	R-5	Rural-5 Acre	Single Family Res-Combo
99 116389 RK	R-5	Rural-5 Acre	Single Family Res-Combo
00 108239 RK	R-5	Rural-5 Acre	Single Family Res-Combo
99 116139 RK	R-8,400	Residential 8,400 sq. ft.	Single Family Res-Combo
98 100452 RK	R-5	Rural-5 Acre	Single Family Res-Combo
98 107705 RK	R-5	Rural-5 Acre	Single Family Res-Combo
00 105502 MH	F	Forestry	Triple Wide
00 102887 RK	R-5	Rural-5 Acre	Single Family Res-Combo
00 104296 RK	R-5	Rural-5 Acre	Single Family Res-Combo
00 105263 MH	R-5	Rural-5 Acre	Triple Wide
00 101199 MH	R-5	Rural-5 Acre	Double Wide
99 115668 RK	R-5	Rural-5 Acre	Single Family Res-Combo
00 102322 RK	R-5	Rural-5 Acre	Single Family Res-Combo
00 102857 MH	F and R	Forestry and Recreation	Double Wide
00 101027 MH	R-5	Rural-5 Acre	Double Wide
00 104994 RK	R-5	Rural-5 Acre	Single Family Res-Combo

Accessory Dwelling Units

Index # - File Name: 1.0022 - Single Family Dwellings Data\_Snohomish County.pdf

00 102108 RK	F	Forestry	Single Family Res-Combo
00 104930 RK	R-5	Rural-5 Acre	Duplex-Combo
99 113487 MH	R-5	Rural-5 Acre	Double Wide
00 106192 MH	R-7,200	Residential 7,200 sq. ft.	Double Wide
00 104303 RK	R-5	Rural-5 Acre	Single Family Res-Combo
00 102977 RK	R-5	Rural-5 Acre	Single Family Res-Combo
99 104732 RK	R-7,200	Residential 7,200 sq. ft.	Single Family Res-Combo
99 113419 RK	R-9,600	Residential 9,600 sq. ft.	Single Family Res-Combo
00 103500 RK	R-9,600	Residential 9,600 sq. ft.	Single Family Res-Combo
97 109637 000 01 RK	R-5	Rural-5 Acre	Single Family Res-Combo
00 100932 RK	R-8,400	Residential 8,400 sq. ft.	Single Family Res-Combo
00 101986 RK	F	Forestry	Single Family Res-Combo
00 102422 MH	R-5	Rural-5 Acre	Single Wide
00 106741 MH	R-5	Rural-5 Acre	Single Wide
99 116125 MH	F	Forestry	Double Wide
00 101775 RK	F	Forestry	Single Family Res-Combo
00 105582 RK	R-5	Rural-5 Acre	Single Family Res-Combo
00 103026 RK	R-5	Rural-5 Acre	Single Family Res-Combo
00 100865 RK	R-5	Rural-5 Acre	SFR-Basic
99 112888 RK	R-5	Rural-5 Acre	Single Family Res-Combo
99 113506 RK	R-9,600	Residential 9,600 sq. ft.	Single Family Res-Combo
00 109514 RK	R-5	Rural-5 Acre	Single Family Res-Combo
00 105307 MH	R-5	Rural-5 Acre	Double Wide
00 102573 MH	R-5	Rural-5 Acre	Double Wide
99 116211 RK	WFB	Waterfront Beach	Single Family Res-Combo
99 112038 RK	R-9,600	Residential 9,600 sq. ft.	Single Family Res-Combo
99 105103 RK	R-5	Rural-5 Acre	Single Family Res-Combo
00 103499 RK	R-5	Rural-5 Acre	Single Family Res-Combo
99 114910 RK	R-5	Rural-5 Acre	Single Family Res-Combo
99 116143 RK	R-5	Rural-5 Acre	Single Family Res-Combo
99 115347 RK	R-5	Rural-5 Acre	Single Family Res-Combo
00 102395 RK	R-5	Rural-5 Acre	Single Family Res-Combo
00 101809 RK	R-5	Rural-5 Acre	Single Family Res-Combo
00 103868 RK	R-5	Rural-5 Acre	Single Family Res-Combo
00 108486 MH	F	Forestry	Double Wide
98 100800 000 01 MH	F	Forestry	Single Wide
00 108830 MH	F	Forestry	Triple Wide
98 108098 RK	F	Forestry	Single Family Res-Combo
99 114998 RK	F	Forestry	Single Family Res-Combo
00 106722 MH	F	Forestry	Double Wide
00 110100 MH	PRD-20,000(M	Residential 20,000 sq. ft.	Double Wide
00 106604 RK	R-5	Rural-5 Acre	Single Family Res-Combo
99 112476 RK	R-5	Rural-5 Acre	Single Family Res-Combo
00 104834 MH	LDMR	Low Density Multiple Reside	Double Wide
00 103515 RK	R-8,400	Residential 8,400 sq. ft.	Single Family Res-Combo
00 104906 RK	R-5	Rural-5 Acre	Single Family Res-Combo
00 101032 RK	R-12,500	Residential 12,500 sq. ft.	Single Family Res-Combo

Accessory Dwelling Units

Index # - File Name: 1.0022 - Single Family Dwellings Data\_Snohomish County.pdf

00 109342 MH	R-12,500	Residential 12,500 sq. ft.	Double Wide
96 108925 000 01 RK	R-5	Rural-5 Acre	Single Family Res-Combo
99 112273 RK	F	Forestry	Single Family Res-Combo
99 110045 MH	R-5	Rural-5 Acre	Single Wide
99 113611 RK	R-5	Rural-5 Acre	Accessory Apt Detached-Combo
99 115909 RK	LDMR	Low Density Multiple Reside	Single Family Res-Combo
00 103364 RK	R-5	Rural-5 Acre	Single Family Res-Combo
99 115767 RK	LDMR	Low Density Multiple Reside	Duplex-Basic
00 108862 RK	R-5	Rural-5 Acre	Single Family Res-Combo
98 108427 RK	R-5	Rural-5 Acre	Single Family Res-Combo
00 100479 RK	R-5	Rural-5 Acre	Single Family Res-Combo
00 103335 RK	R-5	Rural-5 Acre	Single Family Res-Combo
00 104071 MH	R-5	Rural-5 Acre	Double Wide
00 101941 RK	R-5	Rural-5 Acre	Single Family Res-Combo
00 104466 RK	R-5	Rural-5 Acre	Accessory Apt Detached-Combo
99 116085 RK	F	Forestry	Single Family Res-Combo
00 107413 RK	F	Forestry	Single Family Res-Combo
98 150513 MH	F	Forestry	Triple Wide
99 111060 MH	R-5	Rural-5 Acre	Single Wide
00 101021 MH	R-5	Rural-5 Acre	Double Wide
00 103143 RK	R-5	Rural-5 Acre	Single Family Res-Combo
99 101077 RK	R-5	Rural-5 Acre	Single Family Res-Combo
00 103974 MH	R-5	Rural-5 Acre	Double Wide
99 113727 RK	R-5	Rural-5 Acre	Single Family Res-Combo
00 104304 RK	R-5	Rural-5 Acre	Single Family Res-Combo
99 115886 RK	R-5	Rural-5 Acre	Single Family Res-Combo
00 106108 RK	R-5	Rural-5 Acre	Single Family Res-Combo
00 109375 RK	R-5	Rural-5 Acre	Single Family Res-Combo
98 116392 RK	PRD SA-1	Suburban Agriculture-1 Acre	Single Family Res-Combo
98 116393 RK	PRD SA-1	Suburban Agriculture-1 Acre	Single Family Res-Combo
99 102752 RK	R-5	Rural-5 Acre	Single Family Res-Combo
00 104943 RK	R-5	Rural-5 Acre	SFR-Basic
00 102362 RK	WFB	Waterfront Beach	Single Family Res-Combo
00 102549 RK	WFB	Waterfront Beach	Single Family Res-Combo
00 100891 RK	WFB	Waterfront Beach	Accessory Apt Detached-Combo
00 102705 MH	CITY	City	Triple Wide
97 106427 000 01 RK	WFB	Waterfront Beach	Single Family Res-Combo
99 115051 RK	WFB	Waterfront Beach	Single Family Res-Combo
00 106792 RK	R-7,200	Residential 7,200 sq. ft.	Duplex-Combo
00 104342 RK	R-7,200	Residential 7,200 sq. ft.	Duplex-Combo
00 104133 RK	R-8,400	Residential 8,400 sq. ft.	Single Family Res-Combo
00 107917 MH	R-7,200	Residential 7,200 sq. ft.	Single Wide
00 107016 RK	R-9,600	Residential 9,600 sq. ft.	Single Family Res-Combo
00 103358 RK	R-5	Rural-5 Acre	Single Family Res-Combo
00 108853 RK	R-7,200	Residential 7,200 sq. ft.	Single Family Res-Combo
00 108851 RK	R-7,200	Residential 7,200 sq. ft.	Single Family Res-Combo
00 101366 RK	PRD-LDMR	Low Density Multiple Reside	Single Family Res-Combo

Accessory Dwelling Units

Index # - File Name: 1.0022 - Single Family Dwellings Data\_Snohomish County.pdf

00 100873 RK	R-9,600	Residential 9,600 sq. ft.	SFR-Basic
00 101390 RK	R-9,600	Residential 9,600 sq. ft.	Single Family Res-Combo
99 113615 MH	R-5	Rural-5 Acre	Double Wide
96 104189 000 01 MH	R-5	Rural-5 Acre	Single Wide
00 108447 RK	R-5	Rural-5 Acre	Single Family Res-Combo
99 112493 MH	R-5	Rural-5 Acre	Double Wide
00 101912 RK	R-5	Rural-5 Acre	Accessory Apt Detached-Combo
99 115900 RK	R-5	Rural-5 Acre	Single Family Res-Combo
00 103894 RK	R-5	Rural-5 Acre	Single Family Res-Combo
98 108899 000 01 RK	R-5	Rural-5 Acre	Single Family Res-Combo
99 115585 MH	R-5	Rural-5 Acre	Double Wide
00 107007 MH	R-5	Rural-5 Acre	Double Wide
00 107863 RK	R-5	Rural-5 Acre	Single Family Res-Combo
00 104307 MH	CITY	City	Double Wide
00 104095 MH	R-5	Rural-5 Acre	Double Wide
99 116213 RK	R-5	Rural-5 Acre	Single Family Res-Combo
00 106437 RK	R-5	Rural-5 Acre	Single Family Res-Combo
00 109279 MH	R-5	Rural-5 Acre	Double Wide
00 106712 MH	R-5	Rural-5 Acre	Triple Wide
00 103755 MH	CITY	City	Triple Wide
00 101132 MH	R-5	Rural-5 Acre	Double Wide
00 107217 MH	R-5	Rural-5 Acre	Double Wide
00 104851 RK	CITY	City	Duplex-Combo
00 107224 RK	CITY	City	SFR-Basic
99 115483 RK	R-5	Rural-5 Acre	Single Family Res-Combo
99 109512 RK	CITY	City	Single Family Res-Combo
00 105777 RK	R-5	Rural-5 Acre	Single Family Res-Combo
99 116525 MH	R-5	Rural-5 Acre	Triple Wide
00 109325 MH	R-5	Rural-5 Acre	Double Wide
00 108758 MH	R-5	Rural-5 Acre	Single Wide
99 115226 RK	RRT-10	Rural Resource Transition-10	Single Family Res-Combo
00 107105 RK	R-5	Rural-5 Acre	Single Family Res-Combo
99 114436 RK	R-5	Rural-5 Acre	Single Family Res-Combo
99 104776 RK	R-5	Rural-5 Acre	Single Family Res-Combo
00 104955 RK	R-7,200	Residential 7,200 sq. ft.	Single Family Res-Combo
00 106042 RK	CITY	City	Single Family Res-Combo
00 105022 RK	CITY	City	SFR-Basic
99 116140 RK	CITY	City	Duplex-Combo
00 101022 RK	R-7,200	Residential 7,200 sq. ft.	Single Family Res-Combo
99 114873 RK	R-9,600	Residential 9,600 sq. ft.	Single Family Res-Combo
00 104990 MH	R-5	Rural-5 Acre	Double Wide
00 103938 MH	A-10	Agriculture-10 Acre	Double Wide
00 104681 RK	R-7,200	Residential 7,200 sq. ft.	Single Family Res-Combo
98 107241 MH	RRT-10	Rural Resource Transition-10	Double Wide
00 104663 RK	R-7,200	Residential 7,200 sq. ft.	SFR-Basic
00 104674 RK	R-7,200	Residential 7,200 sq. ft.	SFR-Basic
00 104675 RK	R-7,200	Residential 7,200 sq. ft.	SFR-Basic

Accessory Dwelling Units

Index # - File Name: 1.0022 - Single Family Dwellings Data\_Snohomish County.pdf

00 104676 RK	R-7,200	Residential 7,200 sq. ft.	SFR-Basic
00 104667 RK	R-7,200	Residential 7,200 sq. ft.	SFR-Basic
00 104597 RK	R-7,200	Residential 7,200 sq. ft.	SFR-Basic
00 104668 RK	R-7,200	Residential 7,200 sq. ft.	SFR-Basic
00 104664 RK	R-7,200	Residential 7,200 sq. ft.	SFR-Basic
00 101011 RK	R-7,200	Residential 7,200 sq. ft.	Single Family Res-Combo
00 101225 RK	RRT-10	Rural Resource Transition-10	Single Family Res-Combo
99 110595 RK	R-5	Rural-5 Acre	Single Family Res-Combo
00 108241 MH	SA-1	Suburban Agriculture-1 Acre	Double Wide
00 110748 RK	SA-1	Suburban Agriculture-1 Acre	SFR-Basic
00 102301 RK	RRT-10	Rural Resource Transition-10	Single Family Res-Combo
00 100530 RK	RRT-10	Rural Resource Transition-10	Single Family Res-Combo
00 104169 RK	R-5	Rural-5 Acre	Single Family Res-Combo
00 102708 RK	CITY	City	Single Family Res-Combo
00 107270 RK	RRT-10	Rural Resource Transition-10	Single Family Res-Combo
00 107939 MH	RRT-10	Rural Resource Transition-10	Double Wide
00 107752 MH	RRT-10	Rural Resource Transition-10	Triple Wide
00 100868 RK	R-5	Rural-5 Acre	Single Family Res-Combo
00 101002 RK	R-5	Rural-5 Acre	Single Family Res-Combo
00 102295 RK	R-5	Rural-5 Acre	Single Family Res-Combo
99 114299 RK	R-5	Rural-5 Acre	Single Family Res-Combo
00 102300 RK	R-5	Rural-5 Acre	Single Family Res-Combo
99 116220 RK	R-5	Rural-5 Acre	SFR-Basic
00 105680 RK	R-5	Rural-5 Acre	Single Family Res-Combo
00 101767 RK	R-5	Rural-5 Acre	Single Family Res-Combo
00 102350 RK	R-5	Rural-5 Acre	Single Family Res-Combo
00 104049 MH	RRT-10	Rural Resource Transition-10	Triple Wide
00 101109 RK	RRT-10	Rural Resource Transition-10	Single Family Res-Combo
00 107678 RK	RRT-10	Rural Resource Transition-10	Single Family Res-Combo
99 114488 RK	R-5	Rural-5 Acre	Single Family Res-Combo
99 102397 MH	SA-1	Suburban Agriculture-1 Acre	Double Wide
98 104697 000 01 RK	R-5	Rural-5 Acre	Single Family Res-Combo
00 104097 RK	R-5	Rural-5 Acre	Single Family Res-Combo
00 107285 RK	R-5	Rural-5 Acre	Single Family Res-Combo
99 110817 RK	R-5	Rural-5 Acre	Single Family Res-Combo
00 106341 MH	R-5	Rural-5 Acre	
00 102694 MH	R-5	Rural-5 Acre	Double Wide
98 100578 000 01 MH	R-5	Rural-5 Acre	Double Wide
00 102452 RK	R-5	Rural-5 Acre	Single Family Res-Combo
99 115046 RK	R-5	Rural-5 Acre	Single Family Res-Combo
00 103585 RK	R-5	Rural-5 Acre	Single Family Res-Combo
00 106193 RK	R-5	Rural-5 Acre	Single Family Res-Combo
00 102980 RK	R-5	Rural-5 Acre	Single Family Res-Combo
99 112903 RK	A-10	Agriculture-10 Acre	Single Family Res-Combo
00 102640 RK	R-5	Rural-5 Acre	Accessory Apt Detached-Combo
00 103254 RK	R-5	Rural-5 Acre	Single Family Res-Combo
00 103808 RK	R-5	Rural-5 Acre	Single Family Res-Combo

Accessory Dwelling Units

Index # - File Name: 1.0022 - Single Family Dwellings Data\_Snohomish County.pdf

97 111903 000 01 RK	R-5	Rural-5 Acre	Accessory Apt Detached-Combo
00 107380 RK	R-5	Rural-5 Acre	Single Family Res-Combo
99 115349 RK	R-5	Rural-5 Acre	Single Family Res-Combo
00 104449 RK	R-5	Rural-5 Acre	Single Family Res-Combo
00 107384 MH	R-5	Rural-5 Acre	Double Wide
00 104970 RK	R-5	Rural-5 Acre	Single Family Res-Combo
99 115848 MH	R-5	Rural-5 Acre	Double Wide
00 109699 MH	R-5	Rural-5 Acre	Double Wide
00 108310 MH	R-5	Rural-5 Acre	Double Wide
00 110578 MH	R-5	Rural-5 Acre	Double Wide
00 104239 RK	R-5	Rural-5 Acre	Single Family Res-Combo
00 104929 MH	R-5	Rural-5 Acre	Triple Wide
00 105700 MH	R-5	Rural-5 Acre	Single Wide
00 101739 RK	R-5	Rural-5 Acre	Single Family Res-Combo
99 113248 MH	R-5	Rural-5 Acre	Single Wide
00 103433 RK	R-5	Rural-5 Acre	Single Family Res-Combo
99 112325 RK	R-5	Rural-5 Acre	Single Family Res-Combo
99 111769 RK	R-5	Rural-5 Acre	Single Family Res-Combo
00 104333 RK	R-5	Rural-5 Acre	Single Family Res-Combo
99 110934 RK	R-5	Rural-5 Acre	Single Family Res-Combo
00 104524 RK	R-5	Rural-5 Acre	Single Family Res-Combo
99 111828 MH	R-5	Rural-5 Acre	Double Wide
99 111823 RK	R-5	Rural-5 Acre	SFR-Basic
00 101713 RK	R-5	Rural-5 Acre	Single Family Res-Combo
99 112016 RK	R-5	Rural-5 Acre	Single Family Res-Combo
00 108683 RK	R-5	Rural-5 Acre	Single Family Res-Combo
00 106276 RK	R-5	Rural-5 Acre	Single Family Res-Combo
00 106275 RK	R-5	Rural-5 Acre	Single Family Res-Combo
00 105637 MH	R-5	Rural-5 Acre	Double Wide
00 107879 RK	R-5	Rural-5 Acre	Single Family Res-Combo
00 105653 MH	R-5	Rural-5 Acre	Single Wide
97 111891 000 01 RK	R-5	Rural-5 Acre	Single Family Res-Combo
00 101353 RK	R-5	Rural-5 Acre	Single Family Res-Combo
99 116277 RK	R-5	Rural-5 Acre	SFR-Basic
00 100988 RK	R-5	Rural-5 Acre	SFR-Basic
99 112269 MH	R-5	Rural-5 Acre	Double Wide
00 108614 MH	RD	Rural Diversification	Single Wide
00 107182 MH	R-5	Rural-5 Acre	Single Wide
00 106084 RK	RD	Rural Diversification	Single Family Res-Combo
00 105296 RK	R-5	Rural-5 Acre	Single Family Res-Combo
00 106015 MH	RD	Rural Diversification	Triple Wide
00 103975 RK	R-5	Rural-5 Acre	Single Family Res-Combo
99 115833 RK	R-5	Rural-5 Acre	Single Family Res-Combo
97 106959 000 01 RK	R-5	Rural-5 Acre	Single Family Res-Combo
00 109584 RK	R-5	Rural-5 Acre	Single Family Res-Combo
00 105087 RK	R-5	Rural-5 Acre	Single Family Res-Combo
99 110105 MH	R-5	Rural-5 Acre	Double Wide

Accessory Dwelling Units

Index # - File Name: 1.0022 - Single Family Dwellings Data\_Snohomish County.pdf

99 110624 RK	R-5	Rural-5 Acre	Single Family Res-Combo
00 103829 RK	R-5	Rural-5 Acre	Single Family Res-Combo
00 104084 RK	R-5	Rural-5 Acre	Single Family Res-Combo
99 115880 MH	R-5	Rural-5 Acre	Double Wide
00 101202 RK	R-5	Rural-5 Acre	Single Family Res-Combo
97 111775 000 01 RK	R-5	Rural-5 Acre	Single Family Res-Combo
00 107696 MH	R-5 : RC	Rural Conservation : Rural-5	Double Wide
99 115725 MH	R-5	Rural-5 Acre	Double Wide
99 116203 RK	R-5	Rural-5 Acre	Single Family Res-Combo
00 103495 RK	RRT-10	Rural Resource Transition-10	Single Family Res-Combo
00 103097 RK	R-5	Rural-5 Acre	Single Family Res-Combo
00 102311 MH	F	Forestry	Double Wide
00 102312 MH	F	Forestry	Double Wide
00 101642 RK	R-5	Rural-5 Acre	Single Family Res-Combo
00 105518 RK	RD	Rural Diversification	Single Family Res-Combo
00 103171 RK	R-5	Rural-5 Acre	Single Family Res-Combo
00 103202 RK	R-5	Rural-5 Acre	Single Family Res-Combo
00 102348 MH	R-5	Rural-5 Acre	Double Wide
99 110689 RK	R-9,600	Residential 9,600 sq. ft.	Single Family Res-Combo
99 113515 RK	R-5	Rural-5 Acre	Single Family Res-Combo
00 106783 RK	F	Forestry	Single Family Res-Combo
00 104871 RK	F	Forestry	Single Family Res-Combo
00 108230 MH	R-5	Rural-5 Acre	Double Wide
99 113095 RK	RD	Rural Diversification	Single Family Res-Combo
00 105584 RK	R-5	Rural-5 Acre	Single Family Res-Combo
99 112509 RK	R-5	Rural-5 Acre	Single Family Res-Combo
99 113930 RK	R-5	Rural-5 Acre	Single Family Res-Combo
99 116108 RK	R-9,600	Residential 9,600 sq. ft.	Single Family Res-Combo
00 106379 RK	R-5	Rural-5 Acre	Single Family Res-Combo
00 101715 RK	R-5	Rural-5 Acre	Single Family Res-Combo
00 102167 RK	R-5	Rural-5 Acre	Single Family Res-Combo
98 107968 RK	R-5	Rural-5 Acre	Single Family Res-Combo
99 109550 RK	R-5	Rural-5 Acre	Single Family Res-Combo
00 103698 RK	R-5	Rural-5 Acre	Single Family Res-Combo
00 102891 RK	R-5	Rural-5 Acre	Single Family Res-Combo
00 104162 RK	R-5	Rural-5 Acre	Single Family Res-Combo
00 104314 MH	RD	Rural Diversification	Double Wide
00 100802 RK	R-5	Rural-5 Acre	Single Family Res-Combo
00 104818 MH	R-5	Rural-5 Acre	Double Wide
00 107491 RK	R-5	Rural-5 Acre	Single Family Res-Combo
00 107444 MH	R-5	Rural-5 Acre	Double Wide
00 108196 RK	R-5	Rural-5 Acre	Accessory Apt Detached-Combo
00 102310 MH	R-5	Rural-5 Acre	Double Wide
00 101513 RK	A-10	Agriculture-10 Acre	Single Family Res-Combo
00 104965 MH	R-5	Rural-5 Acre	Double Wide
00 107142 MH	F	Forestry	Double Wide
00 110888 MH	RC	Rural Conservation	Single Wide



Accessory Dwelling Units

Index # - File Name: 1.0022 - Single Family Dwellings Data\_Snohomish County.pdf

99 109558 MH	R-5	Rural-5 Acre	Single Wide
99 105445 RK	R-5	Rural-5 Acre	Single Family Res-Combo
00 101330 RK	R-5	Rural-5 Acre	Duplex-Combo
00 103163 RK	A-10	Agriculture-10 Acre	Single Family Res-Combo
99 112265 RK	F	Forestry	Single Family Res-Combo
00 106430 RK	R-5	Rural-5 Acre	Single Family Res-Combo
00 107019 RK	R-5	Rural-5 Acre	Single Family Res-Combo
00 107024 RK	R-5	Rural-5 Acre	Single Family Res-Combo
99 105436 RK	R-5	Rural-5 Acre	Accessory Apt Detached-Combo
00 101519 RK	R-8,400	Residential 8,400 sq. ft.	Duplex-Combo
98 107841 000 01 RK	R-5	Rural-5 Acre	Single Family Res-Combo
97 106751 000 01 RK	F	Forestry	Single Family Res-Combo
00 104928 RK	R-9,600	Residential 9,600 sq. ft.	Single Family Res-Combo
00 104931 RK	R-9,600	Residential 9,600 sq. ft.	Single Family Res-Combo
00 102474 RK	R-9,600	Residential 9,600 sq. ft.	SFR-Basic
00 103766 RK	R-9,600	Residential 9,600 sq. ft.	Single Family Res-Combo
97 108520 000 01 MH	R-5	Rural-5 Acre	Double Wide
99 111904 RK	RC	Rural Conservation	Single Family Res-Combo
00 104878 RK	R-5	Rural-5 Acre	Duplex-Combo
99 113074 RK	R-7,200 : R-9,600	Residential 7,200 sq. ft. : Residential 9,600 sq. ft.	Single Family Res-Combo
99 105024 MH	R-5	Rural-5 Acre	Double Wide
00 101755 RK	F	Forestry	Single Family Res-Combo
00 104584 MH	R-5	Rural-5 Acre	Double Wide
00 102636 RK	R-5	Rural-5 Acre	Single Family Res-Combo
00 101423 MH	R-5	Rural-5 Acre	Double Wide
00 103481 RK	R-5	Rural-5 Acre	Single Family Res-Combo
00 101801 MH	R-5	Rural-5 Acre	Double Wide
00 108969 RK	R-5	Rural-5 Acre	Single Family Res-Combo
99 115660 MH	R-5	Rural-5 Acre	Double Wide
00 100820 RK	R-5	Rural-5 Acre	SFR-Basic
98 100750 MH	R-5	Rural-5 Acre	Single Wide
00 107888 MH	R-5	Rural-5 Acre	Triple Wide
00 104577 RK	R-5	Rural-5 Acre	Single Family Res-Combo
99 112142 RK	R-5	Rural-5 Acre	Single Family Res-Combo
98 106198 RK	R-5	Rural-5 Acre	Single Family Res-Combo
99 111063 MH	R-5	Rural-5 Acre	Triple Wide
98 116170 MH	R-5	Rural-5 Acre	Double Wide
00 103205 RK	R-5	Rural-5 Acre	Single Family Res-Combo
00 106242 RK	R-5	Rural-5 Acre	Single Family Res-Combo
00 102188 RK	R-5	Rural-5 Acre	Single Family Res-Combo
00 103282 RK	R-5	Rural-5 Acre	Single Family Res-Combo
99 115006 RK	R-5	Rural-5 Acre	SFR-Basic
99 114498 RK	R-5	Rural-5 Acre	SFR-Basic
99 110819 RK	R-5	Rural-5 Acre	Single Family Res-Combo
99 113972 RK	R-5	Rural-5 Acre	SFR-Basic
99 113146 RK	R-5	Rural-5 Acre	Single Family Res-Combo
00 102482 RK	R-5	Rural-5 Acre	Single Family Res-Combo

Accessory Dwelling Units

Index # - File Name: 1.0022 - Single Family Dwellings Data\_Snohomish County.pdf

00 102483 RK	R-5	Rural-5 Acre	Single Family Res-Combo
00 105506 RK	R-5	Rural-5 Acre	Single Family Res-Combo
00 107711 RK	R-5	Rural-5 Acre	Single Family Res-Combo
00 101824 RK	R-5	Rural-5 Acre	Single Family Res-Combo
00 101823 RK	R-5	Rural-5 Acre	Single Family Res-Combo
00 104418 RK	R-5	Rural-5 Acre	Single Family Res-Combo
99 113598 RK	R-5	Rural-5 Acre	Single Family Res-Combo
99 113599 RK	R-5	Rural-5 Acre	SFR-Basic
99 113974 RK	R-5	Rural-5 Acre	SFR-Basic
99 114500 RK	R-5	Rural-5 Acre	SFR-Basic
99 114501 RK	R-5	Rural-5 Acre	SFR-Basic
99 114502 RK	R-5	Rural-5 Acre	SFR-Basic
99 113973 RK	R-5	Rural-5 Acre	SFR-Basic
00 106784 MH	CITY	City	Double Wide
00 106983 RK	R-5	Rural-5 Acre	Single Family Res-Combo
98 104817 000 01 RK	R-5	Rural-5 Acre	Single Family Res-Combo
00 102937 RK	R-5	Rural-5 Acre	Single Family Res-Combo
00 102936 RK	R-5	Rural-5 Acre	Single Family Res-Combo
99 115335 RK	R-5	Rural-5 Acre	Single Family Res-Combo
00 100964 RK	R-5	Rural-5 Acre	Duplex-Combo
00 105350 RK	R-5	Rural-5 Acre	SFR-Basic
00 105345 RK	R-5	Rural-5 Acre	SFR-Basic
00 101131 RK	R-5	Rural-5 Acre	Single Family Res-Combo
00 102252 MH	RRT-10	Rural Resource Transition-10	Triple Wide
00 105255 RK	R-9,600	Residential 9,600 sq. ft.	Single Family Res-Combo
98 110388 MH	R-5	Rural-5 Acre	Double Wide
00 102233 RK	A-10	Agriculture-10 Acre	Single Family Res-Combo
00 104582 RK	PRD-LDMR	Low Density Multiple Reside	Single Family Res-Combo
99 113827 RK	PRD-20,000 : F	Low Density Multiple Reside	Single Family Res-Combo
00 102552 RK	R-5	Rural-5 Acre	Single Family Res-Combo
00 105666 MH	R-5	Rural-5 Acre	Double Wide
00 107025 RK	R-5	Rural-5 Acre	Single Family Res-Combo
00 101150 RK	CITY	City	Single Family Res-Combo
00 105793 RK	R-5	Rural-5 Acre	Single Family Res-Combo
00 103190 RK	CITY	City	Single Family Res-Combo
01 110525 RK	A-10	Agriculture-10 Acre	Single Family Res-Combo
01 100070 MH	A-10	Agriculture-10 Acre	Double Wide
00 101750 RK	R-5	Rural-5 Acre	Single Family Res-Combo
99 115918 RK	R-5	Rural-5 Acre	Single Family Res-Combo
01 111340 RK	R-5	Rural-5 Acre	Single Family Res-Combo
00 105717 RK	R-9,600	Residential 9,600 sq. ft.	Single Family Res-Combo
01 103254 RK	R-5	Rural-5 Acre	Single Family Res-Combo
01 110834 RK	R-5	Rural-5 Acre	Single Family Res-Combo
01 107116 RK	R-5	Rural-5 Acre	Single Family Res-Combo
00 109431 RK	R-5	Rural-5 Acre	Single Family Res-Combo
01 103536 RK	R-5	Rural-5 Acre	Single Family Res-Combo
01 105844 RK	TRIBES	Native American Land	Single Family Res-Combo

Accessory Dwelling Units

Index # - File Name: 1.0022 - Single Family Dwellings Data\_Snohomish County.pdf

01 110674 MH	R-5	Rural-5 Acre	Double Wide
01 101394 RK	R-5	Rural-5 Acre	Accessory Apt Detached-Combo
01 107520 RK	R-5	Rural-5 Acre	Single Family Res-Combo
00 110391 RK	R-5	Rural-5 Acre	Single Family Res-Combo
01 110843 MH	R-5	Rural-5 Acre	Double Wide
00 110498 RK	R-5	Rural-5 Acre	Single Family Res-Combo
00 111059 RK	RRT-10	Rural Resource Transition-10	Single Family Res-Combo
01 104983 RK	R-5	Rural-5 Acre	SFR-Basic
01 107055 RK	R-5	Rural-5 Acre	SFR-Basic
01 105120 RK	R-5	Rural-5 Acre	Single Family Res-Combo
00 110645 RK	R-5	Rural-5 Acre	Single Family Res-Combo
01 101380 RK	R-5	Rural-5 Acre	Single Family Res-Combo
01 101062 RK	R-5	Rural-5 Acre	Single Family Res-Combo
01 100041 MH	R-5	Rural-5 Acre	Double Wide
01 103345 RK	R-5	Rural-5 Acre	SFR-Basic
00 109229 RK	R-5	Rural-5 Acre	Single Family Res-Combo
00 107657 RK	R-9,600	Residential 9,600 sq. ft.	Single Family Res-Combo
00 110775 RK	R-5	Rural-5 Acre	Single Family Res-Combo
99 115732 RK	R-5	Rural-5 Acre	Single Family Res-Combo
01 104696 RK	R-5	Rural-5 Acre	Single Family Res-Combo
01 105353 RK	R-5	Rural-5 Acre	Single Family Res-Combo
01 100844 RK	R-5	Rural-5 Acre	Single Family Res-Combo
01 101524 RK	R-5	Rural-5 Acre	Single Family Res-Combo
01 100336 MH	R-5	Rural-5 Acre	Double Wide
01 104053 RK	R-5	Rural-5 Acre	Single Family Res-Combo
01 101074 RK	R-5	Rural-5 Acre	Single Family Res-Combo
01 104103 RK	R-5	Rural-5 Acre	SFR-Basic
01 104271 RK	R-5	Rural-5 Acre	SFR-Basic
01 112573 RK	R-5	Rural-5 Acre	SFR-Basic
01 104270 RK	R-5	Rural-5 Acre	SFR-Basic
01 108034 RK	R-5	Rural-5 Acre	SFR-Basic
98 101957 000 01 RK	R-5	Rural-5 Acre	Single Family Res-Combo
01 100533 MH	R-5	Rural-5 Acre	Double Wide
01 103372 RK	CITY	City	Single Family Res-Combo
00 103562 RK	F	Forestry	Single Family Res-Combo
01 105952 RK	R-7,200	Residential 7,200 sq. ft.	Single Family Res-Combo
01 107398 RK	R-5	Rural-5 Acre	Single Family Res-Combo
01 105101 RK	R-5	Rural-5 Acre	Single Family Res-Combo
01 107115 RK	R-5	Rural-5 Acre	Single Family Res-Combo
01 100810 RK	R-5	Rural-5 Acre	Single Family Res-Combo
99 116151 RK	F	Forestry	Single Family Res-Combo
01 104835 RK	R-5	Rural-5 Acre	Single Family Res-Combo
00 109982 RK	R-5	Rural-5 Acre	Single Family Res-Combo
01 100166 RK	R-5	Rural-5 Acre	Single Family Res-Combo
01 113045 RK	R-9,600	Residential 9,600 sq. ft.	SFR-Basic
01 113044 RK	R-9,600	Residential 9,600 sq. ft.	SFR-Basic
01 106958 MH	R-5	Rural-5 Acre	Double Wide

Accessory Dwelling Units

Index # - File Name: 1.0022 - Single Family Dwellings Data\_Snohomish County.pdf

01 101775 MH	R-5	Rural-5 Acre	Double Wide
00 108688 RK	F	Forestry	Single Family Res-Combo
01 101356 RK	R-5	Rural-5 Acre	Single Family Res-Combo
01 106809 MH	R-5	Rural-5 Acre	Double Wide
01 100440 RK	R-12,500	Residential 12,500 sq. ft.	Single Family Res-Combo
01 107668 RK	RRT-10	Rural Resource Transition-10	SFR-Basic
01 112055 RK	R-5	Rural-5 Acre	Single Family Res-Combo
01 112054 RK	R-5	Rural-5 Acre	Single Family Res-Combo
01 101272 MH	R-12,500	Residential 12,500 sq. ft.	Triple Wide
99 105252 000 01 RK	A-10	Agriculture-10 Acre	Single Family Res-Combo
99 105250 000 01 RK	A-10 : R-5	Agriculture-10 Acre : Rural-5	Single Family Res-Combo
99 105254 000 01 RK	A-10 : R-5	Agriculture-10 Acre : Rural-5	Single Family Res-Combo
99 105257 000 01 RK	A-10	Agriculture-10 Acre	Single Family Res-Combo
99 105249 000 01 RK	A-10	Agriculture-10 Acre	Single Family Res-Combo
99 105256 000 01 RK	A-10	Agriculture-10 Acre	Single Family Res-Combo
99 105248 000 01 RK	A-10 : R-5	Agriculture-10 Acre : Rural-5	Single Family Res-Combo
99 105244 000 01 RK	A-10	Agriculture-10 Acre	Single Family Res-Combo
99 105245 000 01 RK	A-10	Agriculture-10 Acre	Single Family Res-Combo
98 106100 000 01 RK	A-10	Agriculture-10 Acre	SFR-Basic
01 101953 RK	R-5	Rural-5 Acre	Single Family Res-Combo
01 101529 RK	R-5 : R-9,600	Residential 9,600 sq. ft. : Ru	Single Family Res-Combo
01 100280 RK	R-9,600	Residential 9,600 sq. ft.	Single Family Res-Combo
01 104572 RK	R-5	Rural-5 Acre	Accessory Apt Detached-Combo
01 103539 RK	R-9,600	Residential 9,600 sq. ft.	Single Family Res-Combo
01 103865 RK	RC	Rural Conservation	Single Family Res-Combo
00 109505 RK	R-5	Rural-5 Acre	Single Family Res-Combo
00 111038 MH	R-5	Rural-5 Acre	Double Wide
01 106635 MH	R-5	Rural-5 Acre	Double Wide
01 101277 RK	R-5	Rural-5 Acre	Single Family Res-Combo
00 110722 RK	R-5	Rural-5 Acre	Single Family Res-Combo
01 112544 MH	R-5	Rural-5 Acre	Double Wide
01 112061 RK	R-5	Rural-5 Acre	Single Family Res-Combo
00 106187 RK	R-5	Rural-5 Acre	Single Family Res-Combo
98 116131 000 01 RK	R-5	Rural-5 Acre	Single Family Res-Combo
00 105352 RK	RD	Rural Diversification	Single Family Res-Combo
00 110089 RK	CITY	City	Single Family Res-Combo
00 109377 RK	R-5	Rural-5 Acre	Single Family Res-Combo
00 107414 RK	R-5	Rural-5 Acre	Single Family Res-Combo
01 101920 MH	R-5	Rural-5 Acre	Single Wide
00 107953 RK	R-5	Rural-5 Acre	Single Family Res-Combo
01 105638 MH	F	Forestry	Single Wide
01 101894 MH	R-5	Rural-5 Acre	Double Wide
01 105316 RK	F	Forestry	Single Family Res-Combo
00 106272 MH	F	Forestry	Double Wide
99 111567 RK	R-5	Rural-5 Acre	Single Family Res-Combo
00 100997 RK	R-5	Rural-5 Acre	Single Family Res-Combo
01 105318 RK	R-5	Rural-5 Acre	Single Family Res-Combo

Accessory Dwelling Units

Index # - File Name: 1.0022 - Single Family Dwellings Data\_Snohomish County.pdf

01 100397 MH	A-10 : R-5	Agriculture-10 Acre : Rural-5	Double Wide
01 103910 RK	R-5	Rural-5 Acre	Single Family Res-Combo
01 107241 RK	R-5	Rural-5 Acre	Single Family Res-Combo
00 109298 RK	F	Forestry	Single Family Res-Combo
00 110507 RK	R-5	Rural-5 Acre	Single Family Res-Combo
01 108000 RK	R-5	Rural-5 Acre	Single Family Res-Combo
00 108234 RK	R-5	Rural-5 Acre	Single Family Res-Combo
00 107654 RK	R-5	Rural-5 Acre	Single Family Res-Combo
01 105779 RK	R-5	Rural-5 Acre	SFR-Basic
00 111002 RK	R-5	Rural-5 Acre	Single Family Res-Combo
00 109376 RK	R-5	Rural-5 Acre	Single Family Res-Combo
00 108718 RK	R-5	Rural-5 Acre	Single Family Res-Combo
00 108730 RK	R-5	Rural-5 Acre	Single Family Res-Combo
01 110761 RK	R-5	Rural-5 Acre	Single Family Res-Combo
01 106338 RK	R-5	Rural-5 Acre	Single Family Res-Combo
01 104758 MH	R-5	Rural-5 Acre	Double Wide
01 107127 RK	R-5	Rural-5 Acre	Single Family Res-Combo
01 108027 RK	R-5	Rural-5 Acre	Accessory Apt Detached-Combo
99 115307 MH	R-5	Rural-5 Acre	Double Wide
00 108216 MH	R-5	Rural-5 Acre	Double Wide
01 107891 RK	R-5	Rural-5 Acre	Single Family Res-Combo
01 111880 RK	R-5	Rural-5 Acre	SFR-Basic
01 107487 RK	RD	Rural Diversification	Single Family Res-Combo
01 106870 MH	R-5	Rural-5 Acre	Single Wide
01 112371 RK	R-5	Rural-5 Acre	Single Family Res-Combo
00 106063 RK	R-5	Rural-5 Acre	Single Family Res-Combo
01 104668 RK	F : RD	Forestry : Rural Diversification	Single Family Res-Combo
01 105083 RK	R-5	Rural-5 Acre	Single Family Res-Combo
01 107611 RK	RD	Rural Diversification	Single Family Res-Combo
01 103840 MH	R-5	Rural-5 Acre	Single Wide
01 105864 RK	R-5	Rural-5 Acre	Single Family Res-Combo
01 107308 RK	R-5	Rural-5 Acre	Single Family Res-Combo
01 100270 RK	R-5	Rural-5 Acre	Single Family Res-Combo
01 106314 MH	R-5	Rural-5 Acre	Single Wide
00 110900 RK	R-5	Rural-5 Acre	Single Family Res-Combo
01 107138 RK	R-5	Rural-5 Acre	Single Family Res-Combo
01 110642 MH	R-5	Rural-5 Acre	Double Wide
01 105778 RK	R-5	Rural-5 Acre	Single Family Res-Combo
01 111281 RK	R-5	Rural-5 Acre	Single Family Res-Combo
01 112224 MH	R-5	Rural-5 Acre	Triple Wide
01 100659 RK	R-5	Rural-5 Acre	Duplex-Basic
00 108687 RK	R-5	Rural-5 Acre	Single Family Res-Combo
01 104347 RK	R-5	Rural-5 Acre	Single Family Res-Combo
01 110669 RK	R-5	Rural-5 Acre	SFR-Basic
01 107986 RK	R-5	Rural-5 Acre	Single Family Res-Combo
00 109224 RK	R-5	Rural-5 Acre	Single Family Res-Combo
01 110749 RK	R-5	Rural-5 Acre	Single Family Res-Combo

Accessory Dwelling Units

Index # - File Name: 1.0022 - Single Family Dwellings Data\_Snohomish County.pdf

01 110606 MH	R-5	Rural-5 Acre	Double Wide
01 107394 MH	R-5	Rural-5 Acre	Double Wide
00 101431 RK	R-5	Rural-5 Acre	Single Family Res-Combo
99 105216 RK	R-5	Rural-5 Acre	Accessory Apt Detached-Combo
97 108493 000 01 MH	R-5	Rural-5 Acre	Double Wide
01 101755 RK	RC	Rural Conservation	Single Family Res-Combo
01 105620 RK	R-5	Rural-5 Acre	Accessory Apt Detached-Combo
00 104448 RK	R-5	Rural-5 Acre	Single Family Res-Combo
01 101528 RK	R-5	Rural-5 Acre	Single Family Res-Combo
01 104415 RK	R-5	Rural-5 Acre	Single Family Res-Combo
00 102860 RK	R-5	Rural-5 Acre	Single Family Res-Combo
01 100505 RK	R-5	Rural-5 Acre	Single Family Res-Combo
01 103953 RK	R-5	Rural-5 Acre	Single Family Res-Combo
98 117020 RK	R-5	Rural-5 Acre	Single Family Res-Combo
01 105815 RK	R-5	Rural-5 Acre	Single Family Res-Combo
01 108124 RK	R-5	Rural-5 Acre	SFR-Basic
01 104471 RK	R-5	Rural-5 Acre	Single Family Res-Combo
01 105022 MH	R-5	Rural-5 Acre	Triple Wide
01 104428 RK	R-5	Rural-5 Acre	Single Family Res-Combo
01 106960 MH	R-5	Rural-5 Acre	Double Wide
01 110944 RK	R-5	Rural-5 Acre	Single Family Res-Combo
01 111172 RK	R-5	Rural-5 Acre	Single Family Res-Combo
01 100602 RK	R-5	Rural-5 Acre	Single Family Res-Combo
00 109650 RK	R-5	Rural-5 Acre	Single Family Res-Combo
01 104250 MH	R-5	Rural-5 Acre	Double Wide
01 105502 MH	R-5	Rural-5 Acre	Double Wide
01 101520 RK	R-5	Rural-5 Acre	Single Family Res-Combo
00 109127 RK	R-5	Rural-5 Acre	SFR-Basic
00 109329 RK	R-5	Rural-5 Acre	SFR-Basic
00 109330 RK	R-5	Rural-5 Acre	SFR-Basic
00 109355 RK	R-5	Rural-5 Acre	SFR-Basic
01 101425 RK	SA-1	Suburban Agriculture-1 Acre	SFR-Basic
99 102397 000 01 MH	SA-1	Suburban Agriculture-1 Acre	Double Wide
00 110405 MH	R-5	Rural-5 Acre	Double Wide
01 106209 RK	SA-1	Suburban Agriculture-1 Acre	Single Family Res-Combo
01 105341 RK	CITY	City	Duplex-Combo
97 104486 000 01 RK	SA-1	Suburban Agriculture-1 Acre	Single Family Res-Combo
01 100535 MH	RRT-10	Rural Resource Transition-10	Double Wide
01 101424 RK	R-5	Rural-5 Acre	SFR-Basic
00 110097 RK	R-5	Rural-5 Acre	SFR-Basic
01 110787 RK	R-5	Rural-5 Acre	Single Family Res-Combo
01 101270 RK	R-5	Rural-5 Acre	SFR-Basic
01 101273 RK	R-5	Rural-5 Acre	SFR-Basic
01 101391 RK	R-5	Rural-5 Acre	SFR-Basic
01 107905 RK	R-5	Rural-5 Acre	SFR-Basic
01 110902 RK	R-5	Rural-5 Acre	Single Family Res-Combo
01 104614 MH	R-5	Rural-5 Acre	Double Wide

Accessory Dwelling Units

Index # - File Name: 1.0022 - Single Family Dwellings Data\_Snohomish County.pdf

01 107106 MH	R-5	Rural-5 Acre	Double Wide
01 100331 RK	CITY	City	Accessory Apt Detached-Combo
01 101888 MH	SA-1	Suburban Agriculture-1 Acre	Double Wide
01 101059 MH	R-5	Rural-5 Acre	Double Wide
01 103175 RK	R-5	Rural-5 Acre	SFR-Basic
01 111612 MH	R-5	Rural-5 Acre	Double Wide
01 101239 RK	R-5	Rural-5 Acre	Single Family Res-Combo
01 105723 MH	CITY	City	Double Wide
01 104127 MH	RRT-10	Rural Resource Transition-10	Double Wide
01 100127 MH	R-5	Rural-5 Acre	Triple Wide
01 104593 RK	R-5	Rural-5 Acre	SFR-Basic
01 104585 RK	R-5	Rural-5 Acre	SFR-Basic
01 104592 RK	R-5	Rural-5 Acre	SFR-Basic
99 104500 000 01 RK	R-9,600	Residential 9,600 sq. ft.	Single Family Res-Combo
01 107797 MH	R-5	Rural-5 Acre	Triple Wide
00 110086 RK	R-5	Rural-5 Acre	Single Family Res-Combo
01 111209 RK	R-5	Rural-5 Acre	Single Family Res-Combo
01 104138 RK	R-5	Rural-5 Acre	Single Family Res-Combo
01 106220 RK	R-5	Rural-5 Acre	Single Family Res-Combo
01 110876 MH	R-5	Rural-5 Acre	Double Wide
00 110449 MH	R-5	Rural-5 Acre	Double Wide
00 109311 RK	CITY	City	Duplex-Combo
01 104496 RK	R-5	Rural-5 Acre	Single Family Res-Combo
98 109034 000 01 RK	R-5	Rural-5 Acre	Single Family Res-Combo
00 110970 MH	R-5	Rural-5 Acre	Double Wide
00 110660 RK	A-10	Agriculture-10 Acre	Single Family Res-Combo
01 110955 MH	RRT-10	Rural Resource Transition-10	Double Wide
00 108870 RK	RRT-10	Rural Resource Transition-10	Single Family Res-Combo
00 110559 RK	R-5	Rural-5 Acre	Single Family Res-Combo
01 101882 MH	R-5	Rural-5 Acre	Double Wide
01 110857 RK	R-5	Rural-5 Acre	Single Family Res-Combo
01 104610 MH	R-5	Rural-5 Acre	Triple Wide
00 102446 RK	R-5	Rural-5 Acre	Single Family Res-Combo
01 107620 RK	R-5	Rural-5 Acre	SFR-Basic
01 103697 MH	R-5	Rural-5 Acre	Double Wide
00 110599 RK	R-5	Rural-5 Acre	Single Family Res-Combo
01 105692 MH	RRT-10	Rural Resource Transition-10	Double Wide
01 103304 RK	R-5	Rural-5 Acre	Single Family Res-Combo
01 110945 RK	R-5	Rural-5 Acre	Single Family Res-Combo
01 106646 RK	R-5	Rural-5 Acre	Single Family Res-Combo
01 105942 RK	R-5	Rural-5 Acre	Single Family Res-Combo
01 101109 MH	R-5	Rural-5 Acre	Double Wide
00 111065 RK	R-5	Rural-5 Acre	Single Family Res-Combo
01 105292 RK	R-5	Rural-5 Acre	Single Family Res-Combo
01 107603 RK	CITY	City	Single Family Res-Combo
00 108691 RK	R-5	Rural-5 Acre	Single Family Res-Combo
01 111014 RK	R-5	Rural-5 Acre	Single Family Res-Combo

Accessory Dwelling Units

Index # - File Name: 1.0022 - Single Family Dwellings Data\_Snohomish County.pdf

01 101587 RK	CITY	City	Duplex-Combo
01 105831 RK	R-5	Rural-5 Acre	Single Family Res-Combo
01 108097 RK	R-9,600	Residential 9,600 sq. ft.	SFR-Basic
01 105472 MH	R-7,200	Residential 7,200 sq. ft.	Double Wide
99 100507 000 01 MH	CITY	City	Double Wide
00 110889 RK	R-5	Rural-5 Acre	Single Family Res-Combo
01 101897 RK	R-7,200 : R-9,600	Residential 7,200 sq. ft. : Residential 9,600 sq. ft.	Single Family Res-Combo
01 110798 RK	R-9,600	Residential 9,600 sq. ft.	Single Family Res-Combo
99 101378 000 01 MH	R-8,400	Residential 8,400 sq. ft.	Double Wide
00 110072 RK	R-9,600	Residential 9,600 sq. ft.	Single Family Res-Combo
00 109172 RK	F	Forestry	Single Family Res-Combo
00 111096 RK	R-5	Rural-5 Acre	Single Family Res-Combo
00 110238 RK	CITY	City	Single Family Res-Combo
01 101482 RK	CITY	City	Single Family Res-Combo
00 110997 RK	F	Forestry	Single Family Res-Combo
01 100586 MH	R-5	Rural-5 Acre	Double Wide
01 103978 RK	F	Forestry	Single Family Res-Combo
01 110579 MH	R-5	Rural-5 Acre	Triple Wide
00 105651 MH	R-5	Rural-5 Acre	Single Wide
01 107341 MH	R-5	Rural-5 Acre	Triple Wide
01 105017 RK	R-9,600	Residential 9,600 sq. ft.	Single Family Res-Combo
01 107315 RK	R-5	Rural-5 Acre	Single Family Res-Combo
01 111989 MH	R-5	Rural-5 Acre	Triple Wide
00 105887 RK	R-5	Rural-5 Acre	Single Family Res-Combo
01 108156 RK	R-5	Rural-5 Acre	Single Family Res-Combo
01 101234 RK	R-5	Rural-5 Acre	Single Family Res-Combo
01 106207 RK	R-5	Rural-5 Acre	SFR-Basic
00 110358 RK	MR	Multiple Residential	Duplex-Basic
01 107213 RK	R-5	Rural-5 Acre	Accessory Apt Detached-Combo
00 102872 RK	R-5	Rural-5 Acre	Single Family Res-Combo
01 107404 RK	R-5	Rural-5 Acre	Single Family Res-Combo
00 110496 RK	R-9,600	Residential 9,600 sq. ft.	Single Family Res-Combo
00 110497 RK	R-9,600	Residential 9,600 sq. ft.	Single Family Res-Combo
01 108195 MH	R-8,400	Residential 8,400 sq. ft.	Double Wide
01 100616 RK	R-8,400	Residential 8,400 sq. ft.	Duplex-Basic
98 108458 000 01 RK	F	Forestry	Single Family Res-Combo
00 105952 RK	R-5	Rural-5 Acre	Single Family Res-Combo
01 104016 MH	R-5	Rural-5 Acre	Double Wide
99 102385 000 01 MH	F	Forestry	Double Wide
01 105370 RK	R-5	Rural-5 Acre	Single Family Res-Combo
99 104315 RK	R-9,600	Residential 9,600 sq. ft.	Single Family Res-Combo
00 109922 RK	R-9,600	Residential 9,600 sq. ft.	Single Family Res-Combo
01 100513 RK	R-5	Rural-5 Acre	SFR-Basic
01 111377 RK	R-5	Rural-5 Acre	Single Family Res-Combo
01 104882 RK	R-7,200	Residential 7,200 sq. ft.	Accessory Apt Detached-Combo
01 108268 MH	PRD-20,000(M)	Residential 20,000 sq. ft.	Triple Wide
01 106442 MH	F	Forestry	Double Wide



Accessory Dwelling Units

Index # - File Name: 1.0022 - Single Family Dwellings Data\_Snohomish County.pdf

00 110246 MH	F	Forestry	Double Wide
01 111821 RK	F	Forestry	Single Family Res-Combo
01 103541 RK	R-5	Rural-5 Acre	Single Family Res-Combo
01 107339 RK	R-5	Rural-5 Acre	Single Family Res-Combo
00 109112 RK	R-5	Rural-5 Acre	Single Family Res-Combo
01 105263 MH	PRD-20,000(M	Residential 20,000 sq. ft.	Double Wide
01 104780 RK	LDMR	Low Density Multiple Reside	Single Family Res-Combo
01 104765 RK	R-5	Rural-5 Acre	Single Family Res-Combo
01 100278 RK	R-5	Rural-5 Acre	Single Family Res-Combo
01 108231 RK	WFB	Waterfront Beach	Single Family Res-Combo
01 107823 RK	R-9,600	Residential 9,600 sq. ft.	SFR-Basic
01 111642 RK	R-5	Rural-5 Acre	Single Family Res-Combo
01 104641 RK	R-5	Rural-5 Acre	Single Family Res-Combo
00 110307 RK	R-5	Rural-5 Acre	Single Family Res-Combo
01 100841 RK	R-7,200	Residential 7,200 sq. ft.	Single Family Res-Combo
99 103635 000 01 MH	R-5	Rural-5 Acre	Double Wide
01 103880 RK	R-5	Rural-5 Acre	Single Family Res-Combo
01 106785 RK	R-8,400 : R-9,600	Residential 8,400 sq. ft. : Res	Duplex-Basic
01 100536 RK	R-7,200	Residential 7,200 sq. ft.	SFR-Basic
99 110877 RK	R-5	Rural-5 Acre	Single Family Res-Combo
01 103535 MH	R-5	Rural-5 Acre	Single Wide
01 105861 RK	R-5	Rural-5 Acre	Single Family Res-Combo
01 101098 MH	R-5	Rural-5 Acre	Single Wide
00 108680 RK	R-5	Rural-5 Acre	Single Family Res-Combo
01 104470 MH	R-5	Rural-5 Acre	Double Wide
01 106556 MH	R-5	Rural-5 Acre	Double Wide
01 110521 RK	R-5	Rural-5 Acre	SFR-Basic
01 103955 RK	A-10	Agriculture-10 Acre	Single Family Res-Combo
01 111174 RK	R-5	Rural-5 Acre	Single Family Res-Combo
01 110643 RK	R-5	Rural-5 Acre	Single Family Res-Combo
01 106728 RK	R-5	Rural-5 Acre	Single Family Res-Combo
99 109288 MH	R-5	Rural-5 Acre	Double Wide
01 106862 RK	R-5	Rural-5 Acre	Single Family Res-Combo
01 104852 MH	F	Forestry	Triple Wide
98 100452 000 01 RK	R-5	Rural-5 Acre	Single Family Res-Combo
01 103457 RK	CITY	City	Single Family Res-Combo
99 110862 000 01 MH	R-5	Rural-5 Acre	Single Wide
99 110861 000 01 MH	R-5	Rural-5 Acre	Single Wide
01 101001 MH	R-5	Rural-5 Acre	Double Wide
01 104919 RK	R-5	Rural-5 Acre	Single Family Res-Combo
01 105197 RK	R-5	Rural-5 Acre	Single Family Res-Combo
01 100502 RK	R-5	Rural-5 Acre	Single Family Res-Combo
00 109221 RK	R-20,000	Residential 20,000 sq. ft.	Single Family Res-Combo
01 107989 RK	R-5	Rural-5 Acre	SFR-Basic
01 107430 RK	R-5	Rural-5 Acre	Single Family Res-Combo
99 111802 RK	R-5	Rural-5 Acre	Single Family Res-Combo
00 110974 MH	MHP	Mobile Home Park	Double Wide

Accessory Dwelling Units

Index # - File Name: 1.0022 - Single Family Dwellings Data\_Snohomish County.pdf

01 111404 RK	R-5	Rural-5 Acre	SFR-Basic
01 107104 RK	R-5	Rural-5 Acre	Single Family Res-Combo
01 104267 RK	R-5	Rural-5 Acre	Single Family Res-Combo
00 110587 RK	R-5	Rural-5 Acre	Single Family Res-Combo
00 107572 RK	R-5	Rural-5 Acre	Single Family Res-Combo
00 103310 MH	R-5	Rural-5 Acre	Single Wide
00 102840 RK	R-5	Rural-5 Acre	Single Family Res-Combo
01 105200 MH	R-5	Rural-5 Acre	Double Wide
00 110709 RK	R-5	Rural-5 Acre	Single Family Res-Combo
98 103648 000 01 RK	R-5	Rural-5 Acre	Single Family Res-Combo
01 104350 RK	CITY	City	Single Family Res-Combo
01 103220 RK	R-5	Rural-5 Acre	Single Family Res-Combo
00 108414 MH	R-5	Rural-5 Acre	Double Wide
99 109614 RK	R-5	Rural-5 Acre	Single Family Res-Combo
01 104335 RK	RRT-10	Rural Resource Transition-10	Single Family Res-Combo
00 110483 RK	R-5	Rural-5 Acre	Single Family Res-Combo
01 103155 RK	R-5	Rural-5 Acre	Single Family Res-Combo
01 103228 RK	PRD-LDMR	Low Density Multiple Reside	SFR-Basic
01 100837 RK	R-5	Rural-5 Acre	Single Family Res-Combo
01 104975 RK	R-5	Rural-5 Acre	Single Family Res-Combo
01 111959 RK	R-5	Rural-5 Acre	Single Family Res-Combo
01 111903 RK	R-5	Rural-5 Acre	Single Family Res-Combo
99 104330 000 01 RK	R-5	Rural-5 Acre	Single Family Res-Combo
01 100295 RK	CITY	City	Single Family Res-Combo
01 104177 RK	CITY	City	Single Family Res-Combo
01 108020 RK	R-5	Rural-5 Acre	Single Family Res-Combo
98 106441 000 01 RK	PRD SA-1	Suburban Agriculture-1 Acre	SFR-Basic
01 104756 RK	PRD SA-1	Suburban Agriculture-1 Acre	Single Family Res-Combo
01 100485 RK	PRD SA-1	Suburban Agriculture-1 Acre	SFR-Basic
99 112632 RK	PRD SA-1	Suburban Agriculture-1 Acre	SFR-Basic
01 105223 RK	R-5	Rural-5 Acre	Single Family Res-Combo
01 105225 RK	R-5	Rural-5 Acre	Single Family Res-Combo
99 114551 000 01 RK	R-5	Rural-5 Acre	Single Family Res-Combo
00 109180 RK	R-5	Rural-5 Acre	Single Family Res-Combo
01 105752 RK	R-5	Rural-5 Acre	Duplex-Basic
01 101598 RK	R-5	Rural-5 Acre	Single Family Res-Combo
01 106465 RK	CITY	City	Single Family Res-Combo
01 103901 RK	R-5	Rural-5 Acre	Single Family Res-Combo
97 111140 000 01 RK	R-5	Rural-5 Acre	Single Family Res-Combo
00 106959 RK	RRT-10	Rural Resource Transition-10	Single Family Res-Combo
01 104108 MH	R-5	Rural-5 Acre	Single Wide
99 100270 RK	R-5	Rural-5 Acre	Accessory Apt Detached-Combo
01 106924 RK	R-5	Rural-5 Acre	Single Family Res-Combo
01 105179 RK	R-5	Rural-5 Acre	Single Family Res-Combo
01 101276 RK	R-5	Rural-5 Acre	Single Family Res-Combo
01 101092 RK	R-5	Rural-5 Acre	SFR-Basic
01 103456 RK	R-5	Rural-5 Acre	Single Family Res-Combo

Accessory Dwelling Units

Index # - File Name: 1.0022 - Single Family Dwellings Data\_Snohomish County.pdf

01 101289 RK	R-5	Rural-5 Acre	Single Family Res-Combo
00 104900 RK	R-5	Rural-5 Acre	Single Family Res-Combo
01 104252 RK	R-5	Rural-5 Acre	Single Family Res-Combo
01 112872 MH	F	Forestry	Triple Wide
01 101101 RK	R-5	Rural-5 Acre	Single Family Res-Combo
01 104110 RK	R-20,000	Residential 20,000 sq. ft.	SFR-Basic
00 108314 RK	R-5	Rural-5 Acre	Single Family Res-Combo
01 104378 RK	PRD-9,600	Residential 9,600 sq. ft.	SFR-Basic
01 106957 RK	R-5	Rural-5 Acre	Single Family Res-Combo
01 100330 RK	PRD-9,600	Residential 9,600 sq. ft.	Single Family Res-Combo
01 107108 RK	R-5	Rural-5 Acre	Single Family Res-Combo
00 106756 RK	R-5	Rural-5 Acre	Single Family Res-Combo
01 104381 RK	A-10 : R-5	Agriculture-10 Acre : Rural-5	Single Family Res-Combo
01 111856 RK	PRD SA-1	Suburban Agriculture-1 Acre	SFR-Basic
01 112884 RK	PRD SA-1	Suburban Agriculture-1 Acre	SFR-Basic
01 103861 RK	PRD SA-1	Suburban Agriculture-1 Acre	SFR-Basic
01 111497 RK	PRD SA-1	Suburban Agriculture-1 Acre	Single Family Res-Combo
01 101284 RK	PRD SA-1	Suburban Agriculture-1 Acre	SFR-Basic
01 104753 RK	PRD SA-1	Suburban Agriculture-1 Acre	Single Family Res-Combo
01 104282 RK	PRD SA-1	Suburban Agriculture-1 Acre	SFR-Basic
01 108123 RK	PRD SA-1	Suburban Agriculture-1 Acre	SFR-Basic
01 106470 RK	R-5	Rural-5 Acre	Single Family Res-Combo
01 105516 RK	PRD SA-1	Suburban Agriculture-1 Acre	SFR-Basic
01 105518 RK	PRD SA-1	Suburban Agriculture-1 Acre	SFR-Basic
01 105570 RK	PRD SA-1	Suburban Agriculture-1 Acre	SFR-Basic
01 105577 RK	PRD SA-1	Suburban Agriculture-1 Acre	SFR-Basic
01 107557 RK	R-5	Rural-5 Acre	SFR-Basic
01 105459 RK	PRD SA-1	Suburban Agriculture-1 Acre	SFR-Basic
01 112461 RK	PRD SA-1	Suburban Agriculture-1 Acre	SFR-Basic
01 100598 MH	R-5	Rural-5 Acre	Double Wide
01 104370 RK	R-5	Rural-5 Acre	SFR-Basic
01 107949 RK	R-5	Rural-5 Acre	Single Family Res-Combo
01 104384 RK	PRD-9,600	Residential 9,600 sq. ft.	SFR-Basic
01 113049 RK	PRD-9,600	Residential 9,600 sq. ft.	SFR-Basic
01 104936 RK	PRD-9,600	Residential 9,600 sq. ft.	SFR-Basic
01 111618 RK	PRD-9,600	Residential 9,600 sq. ft.	Single Family Res-Combo
01 103349 RK	PRD-9,600	Residential 9,600 sq. ft.	SFR-Basic
00 103996 RK	PRD-9,600	Residential 9,600 sq. ft.	Single Family Res-Combo
01 111621 RK	PRD-9,600	Residential 9,600 sq. ft.	Single Family Res-Combo
01 106679 RK	PRD-9,600	Residential 9,600 sq. ft.	Single Family Res-Combo
01 106693 RK	PRD-9,600	Residential 9,600 sq. ft.	Single Family Res-Combo
01 106694 RK	PRD-9,600	Residential 9,600 sq. ft.	Single Family Res-Combo
01 106677 RK	PRD-9,600	Residential 9,600 sq. ft.	Single Family Res-Combo
01 107270 RK	PRD-9,600	Residential 9,600 sq. ft.	SFR-Basic
01 107271 RK	PRD-9,600	Residential 9,600 sq. ft.	SFR-Basic
01 103351 RK	PRD-9,600	Residential 9,600 sq. ft.	SFR-Basic
01 112962 RK	PRD-9,600	Residential 9,600 sq. ft.	SFR-Basic

Accessory Dwelling Units

Index # - File Name: 1.0022 - Single Family Dwellings Data\_Snohomish County.pdf

01 104609 RK	PRD-9,600	Residential 9,600 sq. ft.	SFR-Basic
00 110567 RK	PRD-9,600	Residential 9,600 sq. ft.	SFR-Basic
00 107859 RK	PRD-9,600	Residential 9,600 sq. ft.	SFR-Basic
00 110569 RK	PRD-9,600	Residential 9,600 sq. ft.	Single Family Res-Combo
99 104337 000 01 RK	R-5	Rural-5 Acre	Single Family Res-Combo
01 101574 RK	R-5	Rural-5 Acre	Single Family Res-Combo
00 110132 RK	R-5	Rural-5 Acre	Single Family Res-Combo
00 109187 RK	R-5	Rural-5 Acre	Single Family Res-Combo
00 106297 RK	R-5	Rural-5 Acre	Single Family Res-Combo
01 100043 RK	R-5	Rural-5 Acre	Single Family Res-Combo
01 101595 RK	R-5	Rural-5 Acre	Single Family Res-Combo
99 116528 MH	A-10 : R-5	Agriculture-10 Acre : Rural-5 Triple Wide	
00 109046 RK	R-5	Rural-5 Acre	Single Family Res-Combo
01 104318 RK	R-9,600	Residential 9,600 sq. ft.	Single Family Res-Combo
01 104587 RK	R-5	Rural-5 Acre	SFR-Basic
00 103147 RK	R-5	Rural-5 Acre	Single Family Res-Combo
01 103373 RK	R-7,200	Residential 7,200 sq. ft.	Single Family Res-Combo
01 106983 RK	R-5	Rural-5 Acre	Single Family Res-Combo
01 101521 RK	R-5	Rural-5 Acre	Single Family Res-Combo
00 109124 RK	R-5	Rural-5 Acre	SFR-Basic
00 109126 RK	R-5	Rural-5 Acre	SFR-Basic
00 109037 RK	R-5	Rural-5 Acre	SFR-Basic
99 110544 000 01 RK	R-5 : RRT-10	Rural Resource Transition-10	Single Family Res-Combo
01 105957 RK	R-5	Rural-5 Acre	Single Family Res-Combo
00 110064 RK	R-5	Rural-5 Acre	Single Family Res-Combo
01 110807 MH	R-5	Rural-5 Acre	Double Wide
00 106364 RK	R-5	Rural-5 Acre	Single Family Res-Combo
00 109411 RK	PRD-9,600	Residential 9,600 sq. ft.	Single Family Res-Combo
99 101224 000 01 RK	R-7,200	Residential 7,200 sq. ft.	Single Family Res-Combo
99 101223 000 01 RK	R-7,200	Residential 7,200 sq. ft.	Single Family Res-Combo
00 110521 RK	R-9,600	Residential 9,600 sq. ft.	Single Family Res-Combo
00 111067 RK	R-9,600	Residential 9,600 sq. ft.	Single Family Res-Combo
01 105668 RK	R-9,600	Residential 9,600 sq. ft.	Single Family Res-Combo
01 100585 RK	R-9,600	Residential 9,600 sq. ft.	Single Family Res-Combo
01 101461 RK	R-9,600	Residential 9,600 sq. ft.	Single Family Res-Combo
01 101460 RK	R-9,600	Residential 9,600 sq. ft.	Single Family Res-Combo
01 101244 RK	R-9,600	Residential 9,600 sq. ft.	Single Family Res-Combo
01 101814 RK	R-9,600	Residential 9,600 sq. ft.	Single Family Res-Combo
01 106323 RK	R-9,600	Residential 9,600 sq. ft.	Single Family Res-Combo
99 100397 000 01 RK	R-7,200	Residential 7,200 sq. ft.	Single Family Res-Combo
01 106801 RK	R-9,600	Residential 9,600 sq. ft.	Single Family Res-Combo
01 107159 RK	R-9,600	Residential 9,600 sq. ft.	Single Family Res-Combo
00 110973 RK	R-9,600	Residential 9,600 sq. ft.	Single Family Res-Combo
01 100489 RK	R-9,600	Residential 9,600 sq. ft.	Single Family Res-Combo
00 111068 RK	R-9,600	Residential 9,600 sq. ft.	Single Family Res-Combo
01 104666 RK	R-9,600	Residential 9,600 sq. ft.	Single Family Res-Combo
01 107068 RK	R-5	Rural-5 Acre	SFR-Basic

Accessory Dwelling Units

Index # - File Name: 1.0022 - Single Family Dwellings Data\_Snohomish County.pdf

01 107922 RK	R-5	Rural-5 Acre	Single Family Res-Combo
01 104910 RK	RD	Rural Diversification	Single Family Res-Combo
01 104007 MH	R-5	Rural-5 Acre	Double Wide
01 111254 RK	CITY	City	Single Family Res-Combo
01 108267 RK	CITY	City	SFR-Basic
01 105024 RK	CITY	City	Single Family Res-Combo
01 104642 RK	CITY	City	SFR-Basic
01 104647 RK	CITY	City	SFR-Basic
01 104644 RK	CITY	City	SFR-Basic
01 104645 RK	CITY	City	SFR-Basic
01 104648 RK	CITY	City	SFR-Basic
01 107680 RK	CITY	City	SFR-Basic
01 110670 RK	CITY	City	SFR-Basic
01 104646 RK	CITY	City	SFR-Basic
01 110968 RK	CITY	City	SFR-Basic
01 105214 RK	CITY	City	SFR-Basic
01 110966 RK	CITY	City	SFR-Basic
01 106573 RK	CITY	City	SFR-Basic
01 106574 RK	CITY	City	SFR-Basic
01 106575 RK	CITY	City	SFR-Basic
01 106567 RK	CITY	City	SFR-Basic
01 110965 RK	CITY	City	SFR-Basic
01 110964 RK	CITY	City	SFR-Basic
01 111250 RK	CITY	City	SFR-Basic
01 111251 RK	CITY	City	SFR-Basic
01 111252 RK	CITY	City	SFR-Basic
01 111571 RK	CITY	City	SFR-Basic
01 111570 RK	CITY	City	SFR-Basic
01 103826 RK	PRD-9,600	Residential 9,600 sq. ft.	SFR-Basic
01 106965 MH	R-5	Rural-5 Acre	Double Wide
01 110507 RK	PRD-9,600	Residential 9,600 sq. ft.	SFR-Basic
01 107570 RK	PRD-9,600	Residential 9,600 sq. ft.	SFR-Basic
01 100494 RK	PRD-9,600	Residential 9,600 sq. ft.	Single Family Res-Combo
01 103827 RK	PRD-9,600	Residential 9,600 sq. ft.	SFR-Basic
01 103833 RK	PRD-9,600	Residential 9,600 sq. ft.	SFR-Basic
01 103490 RK	PRD-9,600	Residential 9,600 sq. ft.	SFR-Basic
01 103487 RK	PRD-9,600	Residential 9,600 sq. ft.	SFR-Basic
01 103494 RK	PRD-9,600	Residential 9,600 sq. ft.	SFR-Basic
01 103493 RK	PRD-9,600	Residential 9,600 sq. ft.	SFR-Basic
01 103484 RK	PRD-9,600	Residential 9,600 sq. ft.	SFR-Basic
01 103495 RK	PRD-9,600	Residential 9,600 sq. ft.	SFR-Basic
01 104142 RK	PRD-9,600	Residential 9,600 sq. ft.	SFR-Basic
01 104144 RK	PRD-9,600	Residential 9,600 sq. ft.	SFR-Basic
01 103485 RK	PRD-9,600	Residential 9,600 sq. ft.	SFR-Basic
01 103489 RK	PRD-9,600	Residential 9,600 sq. ft.	SFR-Basic
01 103486 RK	PRD-9,600	Residential 9,600 sq. ft.	SFR-Basic
01 103496 RK	PRD-9,600	Residential 9,600 sq. ft.	SFR-Basic

Accessory Dwelling Units

Index # - File Name: 1.0022 - Single Family Dwellings Data\_Snohomish County.pdf

01 103491 RK	PRD-9,600	Residential 9,600 sq. ft.	SFR-Basic
01 103492 RK	PRD-9,600	Residential 9,600 sq. ft.	SFR-Basic
01 103497 RK	PRD-9,600	Residential 9,600 sq. ft.	SFR-Basic
01 105033 RK	PRD-9,600	Residential 9,600 sq. ft.	SFR-Basic
01 105034 RK	PRD-9,600	Residential 9,600 sq. ft.	SFR-Basic
01 105036 RK	PRD-9,600	Residential 9,600 sq. ft.	SFR-Basic
01 105042 RK	PRD-9,600	Residential 9,600 sq. ft.	SFR-Basic
01 105041 RK	PRD-9,600	Residential 9,600 sq. ft.	SFR-Basic
01 105037 RK	PRD-9,600	Residential 9,600 sq. ft.	SFR-Basic
01 105039 RK	PRD-9,600	Residential 9,600 sq. ft.	SFR-Basic
01 105035 RK	PRD-9,600	Residential 9,600 sq. ft.	SFR-Basic
01 105038 RK	PRD-9,600	Residential 9,600 sq. ft.	SFR-Basic
01 105443 RK	PRD-9,600	Residential 9,600 sq. ft.	SFR-Basic
01 105447 RK	PRD-9,600	Residential 9,600 sq. ft.	SFR-Basic
01 105450 RK	PRD-9,600	Residential 9,600 sq. ft.	SFR-Basic
01 105040 RK	PRD-9,600	Residential 9,600 sq. ft.	SFR-Basic
01 105451 RK	PRD-9,600	Residential 9,600 sq. ft.	SFR-Basic
01 105449 RK	PRD-9,600	Residential 9,600 sq. ft.	SFR-Basic
01 105453 RK	PRD-9,600	Residential 9,600 sq. ft.	SFR-Basic
01 105445 RK	PRD-9,600	Residential 9,600 sq. ft.	SFR-Basic
01 105455 RK	PRD-9,600	Residential 9,600 sq. ft.	SFR-Basic
01 105452 RK	PRD-9,600	Residential 9,600 sq. ft.	SFR-Basic
01 105446 RK	PRD-9,600	Residential 9,600 sq. ft.	SFR-Basic
01 105454 RK	PRD-9,600	Residential 9,600 sq. ft.	SFR-Basic
01 105448 RK	PRD-9,600	Residential 9,600 sq. ft.	SFR-Basic
01 105444 RK	PRD-9,600	Residential 9,600 sq. ft.	SFR-Basic
01 104143 RK	PRD-9,600	Residential 9,600 sq. ft.	SFR-Basic
01 104141 RK	PRD-9,600	Residential 9,600 sq. ft.	SFR-Basic
01 104140 RK	PRD-9,600	Residential 9,600 sq. ft.	SFR-Basic
01 104139 RK	PRD-9,600	Residential 9,600 sq. ft.	SFR-Basic
01 103704 RK	CITY	City	Duplex-Basic
01 103830 RK	PRD-9,600	Residential 9,600 sq. ft.	SFR-Basic
01 104442 RK	PRD-9,600	Residential 9,600 sq. ft.	SFR-Basic
01 104440 RK	PRD-9,600	Residential 9,600 sq. ft.	SFR-Basic
01 104438 RK	PRD-9,600	Residential 9,600 sq. ft.	SFR-Basic
01 104436 RK	PRD-9,600	Residential 9,600 sq. ft.	SFR-Basic
01 104439 RK	PRD-9,600	Residential 9,600 sq. ft.	SFR-Basic
01 104437 RK	PRD-9,600	Residential 9,600 sq. ft.	SFR-Basic
01 104443 RK	PRD-9,600	Residential 9,600 sq. ft.	SFR-Basic
01 104441 RK	PRD-9,600	Residential 9,600 sq. ft.	SFR-Basic
01 104446 RK	PRD-9,600	Residential 9,600 sq. ft.	SFR-Basic
01 104444 RK	PRD-9,600	Residential 9,600 sq. ft.	SFR-Basic
01 104448 RK	PRD-9,600	Residential 9,600 sq. ft.	SFR-Basic
01 104445 RK	PRD-9,600	Residential 9,600 sq. ft.	SFR-Basic
01 107575 RK	PRD-9,600	Residential 9,600 sq. ft.	SFR-Basic
01 107577 RK	PRD-9,600	Residential 9,600 sq. ft.	SFR-Basic
01 108280 RK	PRD-9,600	Residential 9,600 sq. ft.	SFR-Basic

Accessory Dwelling Units

Index # - File Name: 1.0022 - Single Family Dwellings Data\_Snohomish County.pdf

01 108281 RK	PRD-9,600	Residential 9,600 sq. ft.	SFR-Basic
01 108282 RK	PRD-9,600	Residential 9,600 sq. ft.	SFR-Basic
01 108283 RK	PRD-9,600	Residential 9,600 sq. ft.	SFR-Basic
01 107578 RK	PRD-9,600	Residential 9,600 sq. ft.	SFR-Basic
01 107579 RK	PRD-9,600	Residential 9,600 sq. ft.	SFR-Basic
01 108276 RK	PRD-9,600	Residential 9,600 sq. ft.	SFR-Basic
01 108277 RK	PRD-9,600	Residential 9,600 sq. ft.	SFR-Basic
01 108278 RK	PRD-9,600	Residential 9,600 sq. ft.	SFR-Basic
01 108279 RK	PRD-9,600	Residential 9,600 sq. ft.	SFR-Basic
01 107088 RK	R-5	Rural-5 Acre	Single Family Res-Combo
01 108285 RK	PRD-9,600	Residential 9,600 sq. ft.	SFR-Basic
01 108286 RK	PRD-9,600	Residential 9,600 sq. ft.	SFR-Basic
01 110502 RK	PRD-9,600	Residential 9,600 sq. ft.	SFR-Basic
01 107580 RK	PRD-9,600	Residential 9,600 sq. ft.	SFR-Basic
01 107581 RK	PRD-9,600	Residential 9,600 sq. ft.	SFR-Basic
01 107582 RK	PRD-9,600	Residential 9,600 sq. ft.	SFR-Basic
01 107583 RK	PRD-9,600	Residential 9,600 sq. ft.	SFR-Basic
01 107585 RK	PRD-9,600	Residential 9,600 sq. ft.	SFR-Basic
01 107571 RK	PRD-9,600	Residential 9,600 sq. ft.	SFR-Basic
01 107572 RK	PRD-9,600	Residential 9,600 sq. ft.	SFR-Basic
01 104560 RK	PRD-9,600	Residential 9,600 sq. ft.	SFR-Basic
01 104562 RK	PRD-9,600	Residential 9,600 sq. ft.	SFR-Basic
01 104565 RK	PRD-9,600	Residential 9,600 sq. ft.	SFR-Basic
01 104456 RK	PRD-9,600	Residential 9,600 sq. ft.	SFR-Basic
01 104452 RK	PRD-9,600	Residential 9,600 sq. ft.	SFR-Basic
01 104558 RK	PRD-9,600	Residential 9,600 sq. ft.	SFR-Basic
01 104559 RK	PRD-9,600	Residential 9,600 sq. ft.	SFR-Basic
01 107567 RK	PRD-9,600	Residential 9,600 sq. ft.	SFR-Basic
01 110505 RK	PRD-9,600	Residential 9,600 sq. ft.	SFR-Basic
01 110504 RK	PRD-9,600	Residential 9,600 sq. ft.	SFR-Basic
01 107573 RK	PRD-9,600	Residential 9,600 sq. ft.	SFR-Basic
01 110509 RK	PRD-9,600	Residential 9,600 sq. ft.	SFR-Basic
01 107568 RK	PRD-9,600	Residential 9,600 sq. ft.	SFR-Basic
01 104566 RK	PRD-9,600	Residential 9,600 sq. ft.	SFR-Basic
01 104563 RK	PRD-9,600	Residential 9,600 sq. ft.	SFR-Basic
01 104557 RK	PRD-9,600	Residential 9,600 sq. ft.	SFR-Basic
01 104561 RK	PRD-9,600	Residential 9,600 sq. ft.	SFR-Basic
01 104564 RK	PRD-9,600	Residential 9,600 sq. ft.	SFR-Basic
01 104455 RK	PRD-9,600	Residential 9,600 sq. ft.	SFR-Basic
01 104458 RK	PRD-9,600	Residential 9,600 sq. ft.	SFR-Basic
01 104453 RK	PRD-9,600	Residential 9,600 sq. ft.	SFR-Basic
01 104450 RK	PRD-9,600	Residential 9,600 sq. ft.	SFR-Basic
01 104459 RK	PRD-9,600	Residential 9,600 sq. ft.	SFR-Basic
01 104454 RK	PRD-9,600	Residential 9,600 sq. ft.	SFR-Basic
01 104449 RK	PRD-9,600	Residential 9,600 sq. ft.	SFR-Basic
01 104457 RK	PRD-9,600	Residential 9,600 sq. ft.	SFR-Basic
01 100493 RK	PRD-9,600	Residential 9,600 sq. ft.	Single Family Res-Combo

Accessory Dwelling Units

Index # - File Name: 1.0022 - Single Family Dwellings Data\_Snohomish County.pdf

01 105830 RK	R-5	Rural-5 Acre	Single Family Res-Combo
01 106929 RK	R-5	Rural-5 Acre	SFR-Basic
01 106997 RK	R-5	Rural-5 Acre	SFR-Basic
01 105489 RK	R-5	Rural-5 Acre	Single Family Res-Combo
01 105170 RK	R-5	Rural-5 Acre	Single Family Res-Combo
01 104290 MH	R-5	Rural-5 Acre	Triple Wide
01 104232 MH	F and R : R-5	Forestry and Recreation : Ru	Double Wide
01 106883 RK	R-8,400	Residential 8,400 sq. ft.	Single Family Res-Combo
01 106234 RK	R-8,400	Residential 8,400 sq. ft.	Single Family Res-Combo
01 106235 RK	R-8,400	Residential 8,400 sq. ft.	Single Family Res-Combo
01 105164 RK	R-5	Rural-5 Acre	SFR-Basic
01 107291 RK	R-8,400	Residential 8,400 sq. ft.	Single Family Res-Combo
01 107285 RK	R-8,400	Residential 8,400 sq. ft.	Single Family Res-Combo
01 107957 RK	CITY	City	SFR-Basic
01 107958 RK	CITY	City	SFR-Basic
01 107951 RK	CITY	City	SFR-Basic
01 107950 RK	CITY	City	Single Family Res-Combo
01 107847 RK	CITY	City	SFR-Basic
01 107849 RK	CITY	City	SFR-Basic
01 101441 RK	R-5	Rural-5 Acre	Single Family Res-Combo
01 105434 RK	R-5	Rural-5 Acre	SFR-Basic
01 100901 RK	R-5	Rural-5 Acre	Single Family Res-Combo
00 110431 RK	R-5	Rural-5 Acre	Single Family Res-Combo
01 106680 RK	R-5	Rural-5 Acre	SFR-Basic
01 106682 RK	R-5	Rural-5 Acre	SFR-Basic
01 107796 RK	R-5	Rural-5 Acre	SFR-Basic
01 107799 RK	R-5	Rural-5 Acre	SFR-Basic
01 107801 RK	R-5	Rural-5 Acre	SFR-Basic
01 104704 RK	R-5	Rural-5 Acre	Single Family Res-Combo
01 104792 MH	R-5	Rural-5 Acre	Double Wide
01 106005 RK	PRD-8,400	Residential 8,400 sq. ft.	SFR-Basic
01 106560 RK	PRD-8,400	Residential 8,400 sq. ft.	SFR-Basic
01 108176 RK	PRD-8,400	Residential 8,400 sq. ft.	Single Family Res-Combo
01 106562 RK	PRD-8,400	Residential 8,400 sq. ft.	SFR-Basic
01 108050 RK	PRD-8,400	Residential 8,400 sq. ft.	Single Family Res-Combo
01 106806 RK	PRD-8,400	Residential 8,400 sq. ft.	Single Family Res-Combo
01 108054 RK	PRD-8,400	Residential 8,400 sq. ft.	SFR-Basic
01 106922 RK	PRD-8,400	Residential 8,400 sq. ft.	Single Family Res-Combo
01 106555 RK	PRD-8,400	Residential 8,400 sq. ft.	SFR-Basic
01 106807 RK	PRD-8,400	Residential 8,400 sq. ft.	Single Family Res-Combo
01 108052 RK	PRD-8,400	Residential 8,400 sq. ft.	SFR-Basic
01 105140 RK	PRD-7,200	Residential 7,200 sq. ft.	SFR-Basic
01 105146 RK	PRD-7,200	Residential 7,200 sq. ft.	SFR-Basic
01 105145 RK	PRD-7,200	Residential 7,200 sq. ft.	SFR-Basic
01 105147 RK	PRD-7,200	Residential 7,200 sq. ft.	SFR-Basic
01 105144 RK	PRD-7,200	Residential 7,200 sq. ft.	SFR-Basic
01 105142 RK	PRD-7,200	Residential 7,200 sq. ft.	SFR-Basic



Accessory Dwelling Units

Index # - File Name: 1.0022 - Single Family Dwellings Data\_Snohomish County.pdf

01 105143 RK	PRD-7,200	Residential 7,200 sq. ft.	SFR-Basic
01 105149 RK	PRD-7,200	Residential 7,200 sq. ft.	SFR-Basic
01 105148 RK	PRD-7,200	Residential 7,200 sq. ft.	SFR-Basic
01 104942 MH	R-5	Rural-5 Acre	Double Wide
01 104945 MH	R-5	Rural-5 Acre	Double Wide
01 106008 RK	PRD-8,400	Residential 8,400 sq. ft.	SFR-Basic
01 105018 RK	R-5	Rural-5 Acre	Single Family Res-Combo
01 105196 MH	RRT-10	Rural Resource Transition-10	Double Wide
01 108245 RK	PRD-9,600	Residential 9,600 sq. ft.	SFR-Basic
01 107162 RK	PRD-9,600	Residential 9,600 sq. ft.	Single Family Res-Combo
01 108243 RK	PRD-9,600	Residential 9,600 sq. ft.	SFR-Basic
01 108241 RK	PRD-9,600	Residential 9,600 sq. ft.	SFR-Basic
01 106303 RK	PRD-9,600	Residential 9,600 sq. ft.	Single Family Res-Combo
01 106906 RK	PRD-9,600	Residential 9,600 sq. ft.	Single Family Res-Combo
01 106304 RK	PRD-9,600	Residential 9,600 sq. ft.	Single Family Res-Combo
01 108246 RK	PRD-9,600	Residential 9,600 sq. ft.	SFR-Basic
01 110649 RK	PRD-9,600	Residential 9,600 sq. ft.	SFR-Basic
01 108247 RK	PRD-9,600	Residential 9,600 sq. ft.	SFR-Basic
01 110650 RK	PRD-9,600	Residential 9,600 sq. ft.	SFR-Basic
01 110651 RK	PRD-9,600	Residential 9,600 sq. ft.	SFR-Basic
01 108249 RK	PRD-9,600	Residential 9,600 sq. ft.	SFR-Basic
01 106726 RK	PRD-9,600	Residential 9,600 sq. ft.	Single Family Res-Combo
01 108055 RK	PRD-9,600	Residential 9,600 sq. ft.	Single Family Res-Combo
01 105330 RK	F	Forestry	Single Family Res-Combo
01 107945 RK	R-9,600	Residential 9,600 sq. ft.	SFR-Basic
01 107944 RK	R-9,600	Residential 9,600 sq. ft.	SFR-Basic
01 105605 MH	R-5	Rural-5 Acre	Single Wide
01 110771 RK	R-5	Rural-5 Acre	Single Family Res-Combo
01 105602 RK	R-5	Rural-5 Acre	Single Family Res-Combo
01 107452 RK	R-5	Rural-5 Acre	Single Family Res-Combo
01 100032 RK	R-5	Rural-5 Acre	Single Family Res-Combo
01 107608 RK	RRT-10	Rural Resource Transition-10	Single Family Res-Combo
01 106857 RK	R-5	Rural-5 Acre	Single Family Res-Combo
01 106856 RK	R-5	Rural-5 Acre	Single Family Res-Combo
01 111413 RK	R-5	Rural-5 Acre	SFR-Basic
01 111768 RK	R-9,600	Residential 9,600 sq. ft.	SFR-Basic
01 111916 RK	R-9,600	Residential 9,600 sq. ft.	Single Family Res-Combo
01 111767 RK	R-9,600	Residential 9,600 sq. ft.	SFR-Basic
01 111552 RK	R-9,600	Residential 9,600 sq. ft.	SFR-Basic
01 111769 RK	R-9,600	Residential 9,600 sq. ft.	SFR-Basic
01 111275 RK	R-9,600	Residential 9,600 sq. ft.	SFR-Basic
01 111918 RK	R-9,600	Residential 9,600 sq. ft.	Single Family Res-Combo
01 111915 RK	R-9,600	Residential 9,600 sq. ft.	Single Family Res-Combo
01 111917 RK	R-9,600	Residential 9,600 sq. ft.	Single Family Res-Combo
01 111551 RK	R-9,600	Residential 9,600 sq. ft.	SFR-Basic
01 111919 RK	R-9,600	Residential 9,600 sq. ft.	SFR-Basic
01 111921 RK	R-9,600	Residential 9,600 sq. ft.	SFR-Basic

Accessory Dwelling Units

Index # - File Name: 1.0022 - Single Family Dwellings Data\_Snohomish County.pdf

01 111766 RK	R-9,600	Residential 9,600 sq. ft.	SFR-Basic
01 111550 RK	R-9,600	Residential 9,600 sq. ft.	SFR-Basic
01 105835 RK	R-8,400	Residential 8,400 sq. ft.	SFR-Basic
01 103340 RK	R-5	Rural-5 Acre	Single Family Res-Combo
01 107319 RK	R-5	Rural-5 Acre	SFR-Basic
01 107321 RK	R-5	Rural-5 Acre	SFR-Basic
01 105934 MH	RRT-10	Rural Resource Transition-1( Double Wide	
01 110976 MH	RRT-10	Rural Resource Transition-1( Double Wide	
01 105981 RK	R-5	Rural-5 Acre	Single Family Res-Combo
01 105984 RK			Single Family Res-Combo
01 106925 RK	R-5	Rural-5 Acre	Single Family Res-Combo
01 107317 RK	R-9,600	Residential 9,600 sq. ft.	Single Family Res-Combo
01 111643 RK	R-9,600	Residential 9,600 sq. ft.	Single Family Res-Combo
01 111641 RK	R-9,600	Residential 9,600 sq. ft.	SFR-Basic
01 110564 RK	R-9,600	Residential 9,600 sq. ft.	SFR-Basic
01 111231 RK	R-9,600	Residential 9,600 sq. ft.	SFR-Basic
01 108130 RK	R-9,600	Residential 9,600 sq. ft.	Single Family Res-Combo
01 111233 RK	R-9,600	Residential 9,600 sq. ft.	SFR-Basic
01 106745 RK	R-9,600	Residential 9,600 sq. ft.	Single Family Res-Combo
01 106673 RK	CITY	City	SFR-Basic
01 106674 RK	CITY	City	SFR-Basic
01 106675 RK	CITY	City	SFR-Basic
01 106676 RK	CITY	City	SFR-Basic
01 106270 RK	CITY	City	SFR-Basic
01 103972 RK	CITY	City	Single Family Res-Combo
01 106267 RK	CITY	City	SFR-Basic
01 103971 RK	CITY	City	Single Family Res-Combo
01 107409 RK	PRD-9,600	Residential 9,600 sq. ft.	SFR-Basic
01 107402 RK	PRD-9,600	Residential 9,600 sq. ft.	SFR-Basic
01 103157 RK	PRD-9,600	Residential 9,600 sq. ft.	Single Family Res-Combo
01 112964 RK	PRD-9,600	Residential 9,600 sq. ft.	SFR-Basic
01 108200 RK	PRD-9,600	Residential 9,600 sq. ft.	SFR-Basic
01 108198 RK	PRD-9,600	Residential 9,600 sq. ft.	SFR-Basic
01 104447 RK	PRD-9,600 : R-	Residential 9,600 sq. ft.	Single Family Res-Combo
01 104011 RK	R-9,600	Residential 9,600 sq. ft.	Single Family Res-Combo
01 107492 RK	R-9,600	Residential 9,600 sq. ft.	SFR-Basic
01 107493 RK	R-9,600	Residential 9,600 sq. ft.	SFR-Basic
01 107494 RK	R-9,600	Residential 9,600 sq. ft.	SFR-Basic
01 107498 RK	R-9,600	Residential 9,600 sq. ft.	SFR-Basic
01 107499 RK	R-9,600	Residential 9,600 sq. ft.	SFR-Basic
01 112042 RK	R-9,600	Residential 9,600 sq. ft.	SFR-Basic
01 107165 RK	R-9,600	Residential 9,600 sq. ft.	SFR-Basic
01 107169 RK	R-9,600	Residential 9,600 sq. ft.	SFR-Basic
01 100283 RK	R-9,600	Residential 9,600 sq. ft.	Single Family Res-Combo
01 112045 RK	R-9,600	Residential 9,600 sq. ft.	SFR-Basic
01 112046 RK	R-9,600	Residential 9,600 sq. ft.	SFR-Basic
01 107170 RK	R-9,600	Residential 9,600 sq. ft.	SFR-Basic

Accessory Dwelling Units

Index # - File Name: 1.0022 - Single Family Dwellings Data\_Snohomish County.pdf

01 111896 RK	R-5	Rural-5 Acre	Single Family Res-Combo
01 107548 RK	R-5	Rural-5 Acre	SFR-Basic
01 107167 RK	R-9,600	Residential 9,600 sq. ft.	SFR-Basic
01 105755 RK	R-9,600	Residential 9,600 sq. ft.	Single Family Res-Combo
01 108104 RK	R-9,600	Residential 9,600 sq. ft.	SFR-Basic
01 112047 RK	R-9,600	Residential 9,600 sq. ft.	SFR-Basic
01 112075 RK	R-9,600	Residential 9,600 sq. ft.	SFR-Basic
01 107495 RK	R-9,600	Residential 9,600 sq. ft.	SFR-Basic
01 107500 RK	R-9,600	Residential 9,600 sq. ft.	SFR-Basic
01 107496 RK	R-9,600	Residential 9,600 sq. ft.	SFR-Basic
01 107497 RK	R-9,600	Residential 9,600 sq. ft.	SFR-Basic
01 107501 RK	R-9,600	Residential 9,600 sq. ft.	SFR-Basic
01 107502 RK	R-9,600	Residential 9,600 sq. ft.	SFR-Basic
01 106568 RK	R-5	Rural-5 Acre	Single Family Res-Combo
01 107771 RK	R-5	Rural-5 Acre	SFR-Basic
01 108161 RK	R-9,600	Residential 9,600 sq. ft.	SFR-Basic
01 107960 RK	R-5	Rural-5 Acre	Single Family Res-Combo
01 106788 RK	R-5	Rural-5 Acre	Single Family Res-Combo
01 106869 MH	R-5	Rural-5 Acre	Triple Wide
01 106962 RK	CITY	City	SFR-Basic
01 106967 RK	CITY	City	SFR-Basic
01 107552 RK	R-9,600	Residential 9,600 sq. ft.	SFR-Basic
01 107555 RK	R-9,600	Residential 9,600 sq. ft.	SFR-Basic
01 107554 RK	R-9,600	Residential 9,600 sq. ft.	SFR-Basic
01 107556 RK	R-9,600	Residential 9,600 sq. ft.	SFR-Basic
01 105819 MH	R-5	Rural-5 Acre	MH Park-Double Wide
01 111824 RK	WFB	Waterfront Beach	Single Family Res-Combo
01 112648 RK	MR	Multiple Residential	SFR-Basic
01 111930 RK	R-7,200	Residential 7,200 sq. ft.	SFR-Basic
01 111928 RK	R-7,200	Residential 7,200 sq. ft.	SFR-Basic
01 107468 MH	R-5	Rural-5 Acre	Triple Wide
01 107597 RK	R-5	Rural-5 Acre	Single Family Res-Combo
01 111659 RK	PRD-9,600	Residential 9,600 sq. ft.	SFR-Basic
01 112562 RK	PRD-9,600	Residential 9,600 sq. ft.	Single Family Res-Combo
01 107172 RK	PRD-9,600	Residential 9,600 sq. ft.	SFR-Basic
01 107176 RK	PRD-9,600	Residential 9,600 sq. ft.	SFR-Basic
01 107558 RK	PRD-9,600	Residential 9,600 sq. ft.	SFR-Basic
01 107559 RK	PRD-9,600	Residential 9,600 sq. ft.	SFR-Basic
01 107560 RK	PRD-9,600	Residential 9,600 sq. ft.	SFR-Basic
01 112219 RK	PRD-9,600	Residential 9,600 sq. ft.	Single Family Res-Combo
01 112570 RK	PRD-9,600	Residential 9,600 sq. ft.	Single Family Res-Combo
01 107772 MH	R-5	Rural-5 Acre	Triple Wide
01 108164 RK	R-7,200	Residential 7,200 sq. ft.	SFR-Basic
01 108165 RK	R-7,200	Residential 7,200 sq. ft.	SFR-Basic
01 108166 RK	R-7,200	Residential 7,200 sq. ft.	SFR-Basic
01 108173 RK	R-7,200	Residential 7,200 sq. ft.	SFR-Basic
01 108168 RK	R-7,200	Residential 7,200 sq. ft.	SFR-Basic

Accessory Dwelling Units

Index # - File Name: 1.0022 - Single Family Dwellings Data\_Snohomish County.pdf

01 108170 RK	R-7,200	Residential 7,200 sq. ft.	SFR-Basic
01 108171 RK	R-7,200	Residential 7,200 sq. ft.	SFR-Basic
01 108172 RK	R-7,200	Residential 7,200 sq. ft.	SFR-Basic
01 108175 RK	R-7,200	Residential 7,200 sq. ft.	SFR-Basic
01 112568 RK	PRD-9,600	Residential 9,600 sq. ft.	Single Family Res-Combo
01 107175 RK	PRD-9,600	Residential 9,600 sq. ft.	SFR-Basic
01 107171 RK	PRD-9,600	Residential 9,600 sq. ft.	SFR-Basic
01 110889 RK	R-9,600	Residential 9,600 sq. ft.	Single Family Res-Combo
01 110883 RK	R-9,600	Residential 9,600 sq. ft.	Single Family Res-Combo
01 111240 RK	R-9,600	Residential 9,600 sq. ft.	Single Family Res-Combo
01 110959 RK	R-9,600	Residential 9,600 sq. ft.	Single Family Res-Combo
01 106689 RK	PRD-9,600	Residential 9,600 sq. ft.	SFR-Basic
01 108225 RK	R-7,200	Residential 7,200 sq. ft.	Single Family Res-Combo
01 111526 RK	R-7,200	Residential 7,200 sq. ft.	SFR-Basic
01 111527 RK	R-7,200	Residential 7,200 sq. ft.	SFR-Basic
01 111528 RK	R-7,200	Residential 7,200 sq. ft.	SFR-Basic
01 111525 RK	R-7,200	Residential 7,200 sq. ft.	SFR-Basic
01 110574 RK	PRD-20,000	Residential 20,000 sq. ft.	Single Family Res-Combo
01 107261 RK	R-5	Rural-5 Acre	Single Family Res-Combo
01 111384 RK	R-5	Rural-5 Acre	SFR-Basic
01 111383 RK	R-5	Rural-5 Acre	SFR-Basic
01 111348 RK	R-5	Rural-5 Acre	SFR-Basic
01 111162 RK	PRD-7,200	Residential 7,200 sq. ft.	Single Family Res-Combo
01 110713 RK	PRD-7,200	Residential 7,200 sq. ft.	Single Family Res-Combo
01 113131 RK	PRD-7,200	Residential 7,200 sq. ft.	SFR-Basic
01 110707 RK	PRD-7,200	Residential 7,200 sq. ft.	Single Family Res-Combo
01 110709 RK	PRD-7,200	Residential 7,200 sq. ft.	Single Family Res-Combo
01 110712 RK	PRD-7,200	Residential 7,200 sq. ft.	Single Family Res-Combo
01 112968 RK	PRD-7,200	Residential 7,200 sq. ft.	SFR-Basic
01 112280 RK	PRD-7,200	Residential 7,200 sq. ft.	SFR-Basic
01 112970 RK	PRD-7,200	Residential 7,200 sq. ft.	SFR-Basic
01 112753 RK	PRD-7,200	Residential 7,200 sq. ft.	SFR-Basic
01 110710 RK	PRD-7,200	Residential 7,200 sq. ft.	Single Family Res-Combo
01 111161 RK	PRD-7,200	Residential 7,200 sq. ft.	Single Family Res-Combo
01 112754 RK	PRD-7,200	Residential 7,200 sq. ft.	SFR-Basic
01 110717 RK	PRD-7,200	Residential 7,200 sq. ft.	Single Family Res-Combo
01 111453 RK	CITY	City	SFR-Basic
01 111452 RK	CITY	City	SFR-Basic
01 111451 RK	CITY	City	SFR-Basic
01 105786 RK	CITY	City	Single Family Res-Combo
01 111324 RK	CITY	City	SFR-Basic
01 110708 RK	PRD-7,200	Residential 7,200 sq. ft.	Single Family Res-Combo
01 111455 RK	CITY	City	SFR-Basic
01 111454 RK	CITY	City	SFR-Basic
01 110571 RK	CITY	City	Single Family Res-Combo
01 112977 RK	CITY	City	SFR-Basic
01 111329 RK	CITY	City	SFR-Basic

Accessory Dwelling Units

Index # - File Name: 1.0022 - Single Family Dwellings Data\_Snohomish County.pdf

01 111325 RK	CITY	City	SFR-Basic
99 114218 RK	CITY	City	Single Family Res-Combo
01 111328 RK	CITY	City	SFR-Basic
99 114219 RK	CITY	City	Single Family Res-Combo
01 111323 RK	CITY	City	SFR-Basic
01 111327 RK	CITY	City	SFR-Basic
01 111326 RK	CITY	City	SFR-Basic
01 111456 RK	CITY	City	SFR-Basic
01 111457 RK	CITY	City	SFR-Basic
01 111458 RK	CITY	City	SFR-Basic
01 111187 MH	RD	Rural Diversification	Double Wide
01 111332 RK	R-5	Rural-5 Acre	Single Family Res-Combo
01 111339 RK	R-5	Rural-5 Acre	Single Family Res-Combo
00 107673 RK	R-7,200	Residential 7,200 sq. ft.	Single Family Res-Combo
01 112380 MH	R-5	Rural-5 Acre	Double Wide
01 112295 RK	R-5	Rural-5 Acre	Single Family Res-Combo
01 111797 RK	R-8,400	Residential 8,400 sq. ft.	Single Family Res-Combo
01 112888 RK	CITY	City	SFR-Basic
01 112889 RK	CITY	City	SFR-Basic
01 113101 RK	CITY	City	SFR-Basic
01 112890 RK	CITY	City	SFR-Basic
01 112891 RK	CITY	City	SFR-Basic
01 111945 RK	CITY	City	Single Family Res-Combo
01 112287 RK	CITY	City	SFR-Basic
01 112285 RK	CITY	City	SFR-Basic
01 112845 RK	CITY	City	SFR-Basic
01 112391 RK	CITY	City	Single Family Res-Combo
01 107845 RK	CITY	City	Single Family Res-Combo
01 112288 RK	CITY	City	SFR-Basic
01 112485 RK	CITY	City	SFR-Basic
01 112843 RK	CITY	City	SFR-Basic
01 112844 RK	CITY	City	SFR-Basic
01 112482 RK	CITY	City	SFR-Basic
01 112483 RK	CITY	City	SFR-Basic
01 112484 RK	CITY	City	SFR-Basic
01 112887 RK	CITY	City	SFR-Basic
01 112529 RK	PRD-9,600	Residential 9,600 sq. ft.	SFR-Basic
01 112528 RK	PRD-9,600	Residential 9,600 sq. ft.	SFR-Basic
01 112899 RK	PRD-9,600	Residential 9,600 sq. ft.	SFR-Basic
01 112530 RK	PRD-9,600	Residential 9,600 sq. ft.	SFR-Basic
01 112527 RK	PRD-9,600	Residential 9,600 sq. ft.	SFR-Basic
01 113406 RK	PRD-9,600	Residential 9,600 sq. ft.	SFR-Basic
01 112524 RK	PRD-9,600	Residential 9,600 sq. ft.	SFR-Basic
01 113407 RK	PRD-9,600	Residential 9,600 sq. ft.	SFR-Basic
01 112522 RK	PRD-9,600	Residential 9,600 sq. ft.	SFR-Basic
01 112588 RK	PRD-7,200	Residential 7,200 sq. ft.	SFR-Basic
01 112525 RK	PRD-9,600	Residential 9,600 sq. ft.	SFR-Basic

Accessory Dwelling Units

Index # - File Name: 1.0022 - Single Family Dwellings Data\_Snohomish County.pdf

01 111601 RK	PRD-9,600	Residential 9,600 sq. ft.	Single Family Res-Combo
01 111029 RK	PRD-9,600	Residential 9,600 sq. ft.	Single Family Res-Combo
01 111027 RK	PRD-9,600	Residential 9,600 sq. ft.	Single Family Res-Combo
01 112578 RK	PRD-7,200	Residential 7,200 sq. ft.	SFR-Basic
01 111763 RK	F	Forestry	Single Family Res-Combo
01 112879 RK	R-5	Rural-5 Acre	Single Family Res-Combo
00 110744 RK	PRD-7,200	Residential 7,200 sq. ft.	SFR-Basic
00 110838 RK	PRD-7,200	Residential 7,200 sq. ft.	SFR-Basic
00 110843 RK	PRD-7,200	Residential 7,200 sq. ft.	SFR-Basic
00 110845 RK	PRD-7,200	Residential 7,200 sq. ft.	SFR-Basic
00 110844 RK	PRD-7,200	Residential 7,200 sq. ft.	SFR-Basic
00 110839 RK	PRD-7,200	Residential 7,200 sq. ft.	SFR-Basic
00 110846 RK	PRD-7,200	Residential 7,200 sq. ft.	SFR-Basic
00 110840 RK	PRD-7,200	Residential 7,200 sq. ft.	SFR-Basic
00 110847 RK	PRD-7,200	Residential 7,200 sq. ft.	SFR-Basic
00 110745 RK	PRD-7,200	Residential 7,200 sq. ft.	SFR-Basic
01 101353 RK	PRD-7,200	Residential 7,200 sq. ft.	SFR-Basic
01 101358 RK	PRD-7,200	Residential 7,200 sq. ft.	Single Family Res-Combo
01 100960 RK	PRD-7,200	Residential 7,200 sq. ft.	Single Family Res-Combo
01 101350 RK	PRD-7,200	Residential 7,200 sq. ft.	SFR-Basic
00 110731 RK	PRD-7,200	Residential 7,200 sq. ft.	Single Family Res-Combo
00 110733 RK	PRD-7,200	Residential 7,200 sq. ft.	Single Family Res-Combo
00 111011 RK	PRD-7,200	Residential 7,200 sq. ft.	Duplex-Basic
00 111012 RK	PRD-7,200	Residential 7,200 sq. ft.	Duplex-Basic
01 104720 RK	PRD-7,200	Residential 7,200 sq. ft.	SFR-Basic
01 100541 RK	PRD-9,600	Residential 9,600 sq. ft.	SFR-Basic
01 100544 RK	PRD-9,600	Residential 9,600 sq. ft.	SFR-Basic
01 100542 RK	PRD-9,600	Residential 9,600 sq. ft.	SFR-Basic
01 100324 RK	PRD-9,600	Residential 9,600 sq. ft.	SFR-Basic
00 110725 RK	PRD-9,600	Residential 9,600 sq. ft.	SFR-Basic
00 110726 RK	PRD-9,600	Residential 9,600 sq. ft.	SFR-Basic
01 100328 RK	PRD-9,600	Residential 9,600 sq. ft.	SFR-Basic
00 110727 RK	PRD-9,600	Residential 9,600 sq. ft.	SFR-Basic
00 110728 RK	PRD-9,600	Residential 9,600 sq. ft.	SFR-Basic
01 100327 RK	PRD-9,600	Residential 9,600 sq. ft.	SFR-Basic
00 110729 RK	PRD-9,600	Residential 9,600 sq. ft.	SFR-Basic
00 110730 RK	PRD-9,600	Residential 9,600 sq. ft.	SFR-Basic
00 109960 RK	PRD-9,600	Residential 9,600 sq. ft.	Single Family Res-Combo
01 100543 RK	PRD-9,600	Residential 9,600 sq. ft.	SFR-Basic
01 103300 RK	PRD-9,600	Residential 9,600 sq. ft.	SFR-Basic
00 110881 RK	R-5	Rural-5 Acre	Single Family Res-Combo
00 110837 RK	PRD-7,200	Residential 7,200 sq. ft.	SFR-Basic
00 110849 RK	PRD-7,200	Residential 7,200 sq. ft.	SFR-Basic
00 110841 RK	PRD-7,200	Residential 7,200 sq. ft.	SFR-Basic
00 110850 RK	PRD-7,200	Residential 7,200 sq. ft.	SFR-Basic
00 110842 RK	PRD-7,200	Residential 7,200 sq. ft.	SFR-Basic
00 110851 RK	PRD-7,200	Residential 7,200 sq. ft.	SFR-Basic

Accessory Dwelling Units

Index # - File Name: 1.0022 - Single Family Dwellings Data\_Snohomish County.pdf

00 110746 RK	PRD-7,200	Residential 7,200 sq. ft.	SFR-Basic
00 110747 RK	PRD-7,200	Residential 7,200 sq. ft.	SFR-Basic
01 101385 RK	R-9,600	Residential 9,600 sq. ft.	Single Family Res-Combo
00 111102 MH	R-12,500	Residential 12,500 sq. ft.	Double Wide
01 104858 RK	R-5	Rural-5 Acre	Single Family Res-Combo
01 100011 RK	R-7,200	Residential 7,200 sq. ft.	Duplex-Combo
01 100037 RK	R-5	Rural-5 Acre	Single Family Res-Combo
01 110794 RK	R-5	Rural-5 Acre	SFR-Basic
01 103982 RK	R-5	Rural-5 Acre	Single Family Res-Combo
00 102008 RK	R-5	Rural-5 Acre	SFR-Basic
01 100404 RK	R-5	Rural-5 Acre	Single Family Res-Combo
01 101342 RK	R-5	Rural-5 Acre	SFR-Basic
01 103988 RK	R-5	Rural-5 Acre	Single Family Res-Combo
01 100023 RK	R-8,400	Residential 8,400 sq. ft.	SFR-Basic
01 101047 RK	R-7,200	Residential 7,200 sq. ft.	SFR-Basic
01 103754 RK	R-7,200	Residential 7,200 sq. ft.	SFR-Basic
01 100982 RK	R-7,200	Residential 7,200 sq. ft.	SFR-Basic
00 110886 RK	R-7,200	Residential 7,200 sq. ft.	SFR-Basic
01 103958 RK	R-7,200	Residential 7,200 sq. ft.	SFR-Basic
00 110591 RK	R-7,200	Residential 7,200 sq. ft.	Single Family Res-Combo
00 110885 RK	R-7,200	Residential 7,200 sq. ft.	SFR-Basic
00 110944 RK	R-7,200	Residential 7,200 sq. ft.	SFR-Basic
00 110942 RK	R-7,200	Residential 7,200 sq. ft.	SFR-Basic
01 103755 RK	R-7,200	Residential 7,200 sq. ft.	SFR-Basic
01 100983 RK	R-7,200	Residential 7,200 sq. ft.	SFR-Basic
01 103460 RK	R-7,200	Residential 7,200 sq. ft.	SFR-Basic
00 110941 RK	R-7,200	Residential 7,200 sq. ft.	SFR-Basic
00 110945 RK	R-7,200	Residential 7,200 sq. ft.	SFR-Basic
00 110884 RK	R-7,200	Residential 7,200 sq. ft.	SFR-Basic
00 110943 RK	R-7,200	Residential 7,200 sq. ft.	SFR-Basic
01 100984 RK	R-7,200	Residential 7,200 sq. ft.	SFR-Basic
00 109860 RK	R-7,200	Residential 7,200 sq. ft.	SFR-Basic
00 109859 RK	R-7,200	Residential 7,200 sq. ft.	SFR-Basic
00 109862 RK	R-7,200	Residential 7,200 sq. ft.	SFR-Basic
00 110013 RK	R-7,200	Residential 7,200 sq. ft.	SFR-Basic
01 107008 RK	R-7,200	Residential 7,200 sq. ft.	SFR-Basic
01 101044 RK	R-7,200	Residential 7,200 sq. ft.	SFR-Basic
00 109950 RK	R-7,200	Residential 7,200 sq. ft.	SFR-Basic
00 109953 RK	R-7,200	Residential 7,200 sq. ft.	SFR-Basic
00 109952 RK	R-7,200	Residential 7,200 sq. ft.	SFR-Basic
99 112065 RK	R-7,200	Residential 7,200 sq. ft.	Single Family Res-Combo
00 109863 RK	R-7,200	Residential 7,200 sq. ft.	SFR-Basic
00 110165 RK	R-5	Rural-5 Acre	Single Family Res-Combo
00 108217 RK	R-5	Rural-5 Acre	Single Family Res-Combo
01 101339 RK	R-5	Rural-5 Acre	Single Family Res-Combo
01 101002 RK	R-5	Rural-5 Acre	Single Family Res-Combo
00 110546 RK	R-5	Rural-5 Acre	Single Family Res-Combo

Accessory Dwelling Units

Index # - File Name: 1.0022 - Single Family Dwellings Data\_Snohomish County.pdf

00 110404 RK	MR	Multiple Residential	SFR-Basic
00 109079 RK	MR	Multiple Residential	Single Family Res-Combo
00 109959 RK	PRD-9,600	Residential 9,600 sq. ft.	Single Family Res-Combo
01 103294 RK	PRD-9,600	Residential 9,600 sq. ft.	SFR-Basic
01 103296 RK	PRD-9,600	Residential 9,600 sq. ft.	SFR-Basic
01 101033 RK	PRD-9,600	Residential 9,600 sq. ft.	SFR-Basic
01 101040 RK	PRD-9,600	Residential 9,600 sq. ft.	SFR-Basic
01 100322 RK	PRD-9,600	Residential 9,600 sq. ft.	SFR-Basic
01 101041 RK	PRD-9,600	Residential 9,600 sq. ft.	SFR-Basic
01 101036 RK	PRD-9,600	Residential 9,600 sq. ft.	SFR-Basic
01 103297 RK	PRD-9,600	Residential 9,600 sq. ft.	SFR-Basic
01 103299 RK	PRD-9,600	Residential 9,600 sq. ft.	SFR-Basic
01 101035 RK	PRD-9,600	Residential 9,600 sq. ft.	SFR-Basic
01 101573 RK	PRD-9,600	Residential 9,600 sq. ft.	SFR-Basic
01 101570 RK	PRD-9,600	Residential 9,600 sq. ft.	SFR-Basic
01 101034 RK	PRD-9,600	Residential 9,600 sq. ft.	SFR-Basic
01 101038 RK	PRD-9,600	Residential 9,600 sq. ft.	SFR-Basic
01 101037 RK	PRD-9,600	Residential 9,600 sq. ft.	SFR-Basic
01 100325 RK	PRD-9,600	Residential 9,600 sq. ft.	SFR-Basic
01 100326 RK	PRD-9,600	Residential 9,600 sq. ft.	SFR-Basic
01 100329 RK	PRD-9,600	Residential 9,600 sq. ft.	SFR-Basic
01 100323 RK	PRD-9,600	Residential 9,600 sq. ft.	SFR-Basic
01 103298 RK	PRD-9,600	Residential 9,600 sq. ft.	SFR-Basic
01 105340 RK	PRD-9,600	Residential 9,600 sq. ft.	Single Family Res-Combo
01 100545 RK	PRD-9,600	Residential 9,600 sq. ft.	SFR-Basic
00 110609 RK	PRD-7,200	Residential 7,200 sq. ft.	SFR-Basic
00 110882 RK	PRD-9,600	Residential 9,600 sq. ft.	SFR-Basic
00 109946 RK	R-7,200	Residential 7,200 sq. ft.	SFR-Basic
00 109949 RK	R-7,200	Residential 7,200 sq. ft.	SFR-Basic
00 109855 RK	R-7,200	Residential 7,200 sq. ft.	SFR-Basic
00 109856 RK	R-7,200	Residential 7,200 sq. ft.	SFR-Basic
00 110009 RK	R-7,200	Residential 7,200 sq. ft.	SFR-Basic
01 101046 RK	R-7,200	Residential 7,200 sq. ft.	SFR-Basic
00 110010 RK	R-7,200	Residential 7,200 sq. ft.	SFR-Basic
01 106908 RK	PRD-7,200	Residential 7,200 sq. ft.	Single Family Res-Combo
01 106909 RK	PRD-7,200	Residential 7,200 sq. ft.	SFR-Basic
00 110608 RK	PRD-7,200	Residential 7,200 sq. ft.	SFR-Basic
00 110605 RK	PRD-7,200	Residential 7,200 sq. ft.	SFR-Basic
00 110607 RK	PRD-7,200	Residential 7,200 sq. ft.	SFR-Basic
00 110739 RK	PRD-7,200	Residential 7,200 sq. ft.	SFR-Basic
00 110740 RK	PRD-7,200	Residential 7,200 sq. ft.	SFR-Basic
01 104022 RK	PRD-7,200	Residential 7,200 sq. ft.	Single Family Res-Combo
01 107561 RK	PRD-7,200	Residential 7,200 sq. ft.	Single Family Res-Combo
00 106028 RK	PRD-7,200	Residential 7,200 sq. ft.	Single Family Res-Combo
01 101011 RK	PRD-7,200	Residential 7,200 sq. ft.	Single Family Res-Combo
01 101903 RK	R-5	Rural-5 Acre	Single Family Res-Combo
01 107965 RK	R-9,600	Residential 9,600 sq. ft.	SFR-Basic



Accessory Dwelling Units

Index # - File Name: 1.0022 - Single Family Dwellings Data\_Snohomish County.pdf

01 104104 RK	R-9,600	Residential 9,600 sq. ft.	SFR-Basic
01 106334 RK	R-5	Rural-5 Acre	Single Family Res-Combo
01 110908 RK	R-5	Rural-5 Acre	SFR-Basic
01 108135 RK	MR	Multiple Residential	SFR-Basic
01 101281 RK	R-9,600	Residential 9,600 sq. ft.	Single Family Res-Combo
01 105460 RK	R-9,600	Residential 9,600 sq. ft.	SFR-Basic
01 101811 RK	R-9,600	Residential 9,600 sq. ft.	Single Family Res-Combo
00 109288 RK	R-9,600	Residential 9,600 sq. ft.	Single Family Res-Combo
00 110122 RK	R-9,600	Residential 9,600 sq. ft.	Single Family Res-Combo
01 107034 RK	R-9,600	Residential 9,600 sq. ft.	SFR-Basic
01 104106 RK	R-9,600	Residential 9,600 sq. ft.	SFR-Basic
00 110514 RK	PRD-7,200	Residential 7,200 sq. ft.	SFR-Basic
01 100116 RK	PRD-7,200	Residential 7,200 sq. ft.	SFR-Basic
01 100122 RK	PRD-7,200	Residential 7,200 sq. ft.	SFR-Basic
01 100123 RK	PRD-7,200	Residential 7,200 sq. ft.	SFR-Basic
01 100118 RK	PRD-7,200	Residential 7,200 sq. ft.	SFR-Basic
01 100808 RK	PRD-7,200	Residential 7,200 sq. ft.	SFR-Basic
01 100119 RK	PRD-7,200	Residential 7,200 sq. ft.	SFR-Basic
01 100112 RK	PRD-7,200	Residential 7,200 sq. ft.	SFR-Basic
01 100803 RK	PRD-7,200	Residential 7,200 sq. ft.	SFR-Basic
01 100806 RK	PRD-7,200	Residential 7,200 sq. ft.	SFR-Basic
00 110516 RK	PRD-7,200	Residential 7,200 sq. ft.	SFR-Basic
01 100802 RK	PRD-7,200	Residential 7,200 sq. ft.	SFR-Basic
01 100804 RK	PRD-7,200	Residential 7,200 sq. ft.	SFR-Basic
01 105525 RK	PRD-7,200	Residential 7,200 sq. ft.	SFR-Basic
01 105521 RK	PRD-7,200	Residential 7,200 sq. ft.	SFR-Basic
01 100805 RK	PRD-7,200	Residential 7,200 sq. ft.	SFR-Basic
01 107628 RK	PRD-7,200	Residential 7,200 sq. ft.	SFR-Basic
01 104656 RK	PRD-7,200	Residential 7,200 sq. ft.	SFR-Basic
01 107630 RK	PRD-7,200	Residential 7,200 sq. ft.	SFR-Basic
01 106786 RK	PRD-7,200	Residential 7,200 sq. ft.	SFR-Basic
01 110844 RK	PRD-7,200	Residential 7,200 sq. ft.	SFR-Basic
01 111210 RK	PRD-7,200	Residential 7,200 sq. ft.	SFR-Basic
01 111211 RK	PRD-7,200	Residential 7,200 sq. ft.	SFR-Basic
00 106668 RK	PRD-7,200	Residential 7,200 sq. ft.	Single Family Res-Combo
01 111302 RK	R-9,600	Residential 9,600 sq. ft.	Single Family Res-Combo
00 110300 RK	R-9,600	Residential 9,600 sq. ft.	Single Family Res-Combo
00 108410 RK	R-9,600	Residential 9,600 sq. ft.	Single Family Res-Combo
01 105319 RK	R-9,600	Residential 9,600 sq. ft.	SFR-Basic
01 105457 RK	R-9,600	Residential 9,600 sq. ft.	SFR-Basic
01 104728 RK	R-9,600	Residential 9,600 sq. ft.	SFR-Basic
00 110933 RK	R-9,600	Residential 9,600 sq. ft.	Single Family Res-Combo
01 100587 RK	R-9,600	Residential 9,600 sq. ft.	SFR-Basic
01 110552 RK	R-9,600	Residential 9,600 sq. ft.	SFR-Basic
01 101280 RK	R-9,600	Residential 9,600 sq. ft.	SFR-Basic
01 112619 RK	R-9,600	Residential 9,600 sq. ft.	SFR-Basic
01 104916 RK	R-9,600	Residential 9,600 sq. ft.	SFR-Basic

Accessory Dwelling Units

Index # - File Name: 1.0022 - Single Family Dwellings Data\_Snohomish County.pdf

01 110554 RK	R-9,600	Residential 9,600 sq. ft.	SFR-Basic
01 110555 RK	R-9,600	Residential 9,600 sq. ft.	Single Family Res-Combo
01 108091 RK	R-9,600	Residential 9,600 sq. ft.	SFR-Basic
01 106000 RK	R-7,200	Residential 7,200 sq. ft.	SFR-Basic
01 106319 RK	R-7,200	Residential 7,200 sq. ft.	SFR-Basic
01 106322 RK	R-7,200	Residential 7,200 sq. ft.	Single Family Res-Combo
01 104309 RK	R-7,200	Residential 7,200 sq. ft.	SFR-Basic
01 106320 RK	R-7,200	Residential 7,200 sq. ft.	SFR-Basic
01 110909 RK	R-5	Rural-5 Acre	Single Family Res-Combo
00 109681 RK	R-5	Rural-5 Acre	Single Family Res-Combo
00 109682 RK	R-5	Rural-5 Acre	Single Family Res-Combo
01 104171 RK	R-5	Rural-5 Acre	Single Family Res-Combo
00 109145 RK	R-5	Rural-5 Acre	Single Family Res-Combo
01 107688 RK	R-5	Rural-5 Acre	Single Family Res-Combo
00 110344 MH	R-5	Rural-5 Acre	Double Wide
01 101582 RK	R-5	Rural-5 Acre	Single Family Res-Combo
01 105999 RK	R-7,200	Residential 7,200 sq. ft.	SFR-Basic
01 106001 RK	R-7,200	Residential 7,200 sq. ft.	SFR-Basic
01 111586 RK	R-7,200	Residential 7,200 sq. ft.	SFR-Basic
01 104663 RK	R-7,200	Residential 7,200 sq. ft.	Single Family Res-Combo
01 100997 RK	R-7,200	Residential 7,200 sq. ft.	SFR-Basic
01 104531 RK	R-7,200	Residential 7,200 sq. ft.	Single Family Res-Combo
01 100407 RK	R-7,200	Residential 7,200 sq. ft.	SFR-Basic
01 100998 RK	R-7,200	Residential 7,200 sq. ft.	SFR-Basic
00 110517 RK	R-7,200	Residential 7,200 sq. ft.	SFR-Basic
00 110519 RK	R-7,200	Residential 7,200 sq. ft.	SFR-Basic
01 104308 RK	R-7,200	Residential 7,200 sq. ft.	Single Family Res-Combo
01 110582 RK	R-7,200	Residential 7,200 sq. ft.	SFR-Basic
01 100999 RK	R-7,200	Residential 7,200 sq. ft.	Single Family Res-Combo
00 110518 RK	R-7,200	Residential 7,200 sq. ft.	SFR-Basic
00 110520 RK	R-7,200	Residential 7,200 sq. ft.	SFR-Basic
01 104307 RK	R-7,200	Residential 7,200 sq. ft.	Single Family Res-Combo
01 101070 RK	R-7,200	Residential 7,200 sq. ft.	SFR-Basic
01 100490 RK	R-7,200	Residential 7,200 sq. ft.	SFR-Basic
01 101069 RK	R-7,200	Residential 7,200 sq. ft.	SFR-Basic
01 107917 RK	R-7,200	Residential 7,200 sq. ft.	SFR-Basic
00 110751 RK	PRD-7,200	Residential 7,200 sq. ft.	SFR-Basic
00 110755 RK	PRD-7,200	Residential 7,200 sq. ft.	SFR-Basic
00 110752 RK	PRD-7,200	Residential 7,200 sq. ft.	SFR-Basic
00 111085 RK	PRD-7,200	Residential 7,200 sq. ft.	Single Family Res-Combo
00 110753 RK	PRD-7,200	Residential 7,200 sq. ft.	SFR-Basic
00 110757 RK	PRD-7,200	Residential 7,200 sq. ft.	SFR-Basic
00 110758 RK	PRD-7,200	Residential 7,200 sq. ft.	SFR-Basic
00 110759 RK	PRD-7,200	Residential 7,200 sq. ft.	SFR-Basic
00 110754 RK	PRD-7,200	Residential 7,200 sq. ft.	SFR-Basic
01 107005 RK	R-5	Rural-5 Acre	Single Family Res-Combo
00 110760 RK	PRD-7,200	Residential 7,200 sq. ft.	SFR-Basic

Accessory Dwelling Units

Index # - File Name: 1.0022 - Single Family Dwellings Data\_Snohomish County.pdf

01 104906 RK	R-5	Rural-5 Acre	Single Family Res-Combo
01 106629 RK	R-5	Rural-5 Acre	Single Family Res-Combo
00 111080 RK	R-5	Rural-5 Acre	SFR-Basic
01 100384 RK	R-5	Rural-5 Acre	Single Family Res-Combo
01 101800 RK	R-5	Rural-5 Acre	Single Family Res-Combo
01 108006 RK	R-5	Rural-5 Acre	Single Family Res-Combo
01 110747 RK	R-5	Rural-5 Acre	Single Family Res-Combo
01 106601 RK	R-5	Rural-5 Acre	Single Family Res-Combo
00 110694 RK	R-5	Rural-5 Acre	SFR-Basic
00 109983 RK	CITY	City	Single Family Res-Combo
00 109685 RK	CITY	City	Single Family Res-Combo
01 101220 RK	CITY	City	SFR-Basic
00 108630 RK	CITY	City	Single Family Res-Combo
00 109684 RK	CITY	City	Single Family Res-Combo
01 100452 RK	CITY	City	SFR-Basic
01 107918 RK	R-5	Rural-5 Acre	Single Family Res-Combo
01 106505 RK	PRD-LDMR	Low Density Multiple Reside	SFR-Basic
01 104599 RK	PRD-LDMR	Low Density Multiple Reside	SFR-Basic
01 104229 RK	PRD-LDMR	Low Density Multiple Reside	Single Family Res-Combo
01 107191 RK	PRD-LDMR	Low Density Multiple Reside	SFR-Basic
01 106739 RK	PRD-LDMR	Low Density Multiple Reside	Single Family Res-Combo
01 104603 RK	PRD-LDMR	Low Density Multiple Reside	SFR-Basic
01 107004 RK	PRD-LDMR	Low Density Multiple Reside	SFR-Basic
01 107193 RK	PRD-LDMR	Low Density Multiple Reside	SFR-Basic
01 104773 RK	PRD-LDMR	Low Density Multiple Reside	SFR-Basic
01 107795 RK	PRD-LDMR	Low Density Multiple Reside	SFR-Basic
01 105610 RK	PRD-LDMR	Low Density Multiple Reside	Single Family Res-Combo
01 104604 RK	PRD-LDMR	Low Density Multiple Reside	SFR-Basic
01 104597 RK	PRD-LDMR	Low Density Multiple Reside	SFR-Basic
01 106507 RK	PRD-LDMR	Low Density Multiple Reside	SFR-Basic
01 107003 RK	PRD-LDMR	Low Density Multiple Reside	SFR-Basic
01 106714 RK	PRD-LDMR	Low Density Multiple Reside	SFR-Basic
01 106931 RK	PRD-LDMR	Low Density Multiple Reside	SFR-Basic
01 106715 RK	PRD-LDMR	Low Density Multiple Reside	SFR-Basic
01 104601 RK	PRD-LDMR	Low Density Multiple Reside	SFR-Basic
01 104602 RK	PRD-LDMR	Low Density Multiple Reside	SFR-Basic
01 104770 RK	PRD-LDMR	Low Density Multiple Reside	SFR-Basic
01 104596 RK	PRD-LDMR	Low Density Multiple Reside	SFR-Basic
01 105013 RK	PRD-LDMR	Low Density Multiple Reside	Single Family Res-Combo
01 104600 RK	PRD-LDMR	Low Density Multiple Reside	SFR-Basic
01 100455 RK	CITY	City	SFR-Basic
00 109981 RK	CITY	City	Single Family Res-Combo
01 100451 RK	CITY	City	SFR-Basic
01 100454 RK	CITY	City	SFR-Basic
00 110468 RK	PRD-7,200	Residential 7,200 sq. ft.	SFR-Basic
01 110519 RK	R-5	Rural-5 Acre	Single Family Res-Combo
01 101218 RK	CITY	City	SFR-Basic

Accessory Dwelling Units

Index # - File Name: 1.0022 - Single Family Dwellings Data\_Snohomish County.pdf

01 100450 RK	CITY	City	SFR-Basic
01 101219 RK	CITY	City	SFR-Basic
01 100453 RK	CITY	City	SFR-Basic
00 110473 RK	PRD-7,200	Residential 7,200 sq. ft.	SFR-Basic
00 110476 RK	PRD-7,200	Residential 7,200 sq. ft.	SFR-Basic
00 110467 RK	PRD-7,200	Residential 7,200 sq. ft.	SFR-Basic
00 110129 RK	PRD-7,200	Residential 7,200 sq. ft.	Single Family Res-Combo
00 108344 MH	RD	Rural Diversification	Double Wide
01 106941 RK	R-5	Rural-5 Acre	SFR-Basic
00 110992 RK	PRD-7,200	Residential 7,200 sq. ft.	SFR-Basic
00 110993 RK	PRD-7,200	Residential 7,200 sq. ft.	SFR-Basic
00 110994 RK	PRD-7,200	Residential 7,200 sq. ft.	SFR-Basic
00 110995 RK	PRD-7,200	Residential 7,200 sq. ft.	Single Family Res-Combo
01 108224 RK	R-5	Rural-5 Acre	SFR-Basic
00 111108 RK	R-5	Rural-5 Acre	SFR-Basic
01 101258 RK	R-5	Rural-5 Acre	SFR-Basic
01 103903 RK	R-5	Rural-5 Acre	SFR-Basic
01 101256 RK	R-5	Rural-5 Acre	SFR-Basic
01 103238 RK	R-5	Rural-5 Acre	SFR-Basic
01 106937 RK	R-5	Rural-5 Acre	Single Family Res-Combo
01 101255 RK	R-5	Rural-5 Acre	SFR-Basic
00 110571 RK	R-5	Rural-5 Acre	SFR-Basic
00 110572 RK	R-5	Rural-5 Acre	SFR-Basic
01 101259 RK	R-5	Rural-5 Acre	SFR-Basic
01 101253 RK	R-5	Rural-5 Acre	SFR-Basic
00 110570 RK	R-5	Rural-5 Acre	SFR-Basic
01 112083 RK	R-5	Rural-5 Acre	Single Family Res-Combo
01 103376 RK	PRD-9,600	Residential 9,600 sq. ft.	SFR-Basic
00 108891 RK	PRD-9,600	Residential 9,600 sq. ft.	Single Family Res-Combo
00 110664 RK	PRD-9,600	Residential 9,600 sq. ft.	SFR-Basic
01 103378 RK	PRD-9,600	Residential 9,600 sq. ft.	SFR-Basic
01 105174 RK	PRD-9,600	Residential 9,600 sq. ft.	SFR-Basic
01 100368 RK	PRD-9,600	Residential 9,600 sq. ft.	Single Family Res-Combo
01 105977 RK	PRD-9,600	Residential 9,600 sq. ft.	SFR-Basic
00 110662 RK	PRD-9,600	Residential 9,600 sq. ft.	SFR-Basic
01 105175 RK	PRD-9,600	Residential 9,600 sq. ft.	SFR-Basic
01 103377 RK	PRD-9,600	Residential 9,600 sq. ft.	SFR-Basic
01 105173 RK	PRD-9,600	Residential 9,600 sq. ft.	SFR-Basic
00 109585 RK	R-5	Rural-5 Acre	Single Family Res-Combo
00 109430 RK	R-5	Rural-5 Acre	Single Family Res-Combo
00 111030 RK	R-5	Rural-5 Acre	Single Family Res-Combo
01 111827 MH	R-5	Rural-5 Acre	Double Wide
01 105978 RK	PRD-9,600	Residential 9,600 sq. ft.	SFR-Basic
01 105176 RK	PRD-9,600	Residential 9,600 sq. ft.	SFR-Basic
01 111837 RK	PRD-9,600	Residential 9,600 sq. ft.	SFR-Basic
01 103375 RK	PRD-9,600	Residential 9,600 sq. ft.	SFR-Basic
01 100371 RK	PRD-9,600	Residential 9,600 sq. ft.	SFR-Basic

Accessory Dwelling Units

Index # - File Name: 1.0022 - Single Family Dwellings Data\_Snohomish County.pdf

01 100372 RK	PRD-9,600	Residential 9,600 sq. ft.	SFR-Basic
01 100417 RK	PRD-9,600	Residential 9,600 sq. ft.	SFR-Basic
00 110665 RK	PRD-9,600	Residential 9,600 sq. ft.	SFR-Basic
01 106288 RK	PRD-9,600	Residential 9,600 sq. ft.	Single Family Res-Combo
01 111142 RK	PRD-9,600	Residential 9,600 sq. ft.	SFR-Basic
01 111044 RK	PRD-9,600	Residential 9,600 sq. ft.	SFR-Basic
00 109318 RK	PRD-9,600	Residential 9,600 sq. ft.	Single Family Res-Combo
01 104463 RK	PRD-7,200	Residential 7,200 sq. ft.	Single Family Res-Combo
01 104468 RK	PRD-7,200	Residential 7,200 sq. ft.	SFR-Basic
01 101609 RK	PRD-7,200	Residential 7,200 sq. ft.	SFR-Basic
01 104469 RK	PRD-7,200	Residential 7,200 sq. ft.	SFR-Basic
01 101600 RK	PRD-7,200	Residential 7,200 sq. ft.	SFR-Basic
00 109794 RK	PRD-7,200	Residential 7,200 sq. ft.	Single Family Res-Combo
00 109802 RK	PRD-7,200	Residential 7,200 sq. ft.	Single Family Res-Combo
00 109804 RK	PRD-7,200	Residential 7,200 sq. ft.	Single Family Res-Combo
00 109801 RK	PRD-7,200	Residential 7,200 sq. ft.	Single Family Res-Combo
00 109809 RK	PRD-7,200	Residential 7,200 sq. ft.	Single Family Res-Combo
00 109810 RK	PRD-7,200	Residential 7,200 sq. ft.	Single Family Res-Combo
00 109067 RK	R-5	Rural-5 Acre	Single Family Res-Combo
01 105628 RK	R-5	Rural-5 Acre	Single Family Res-Combo
01 106812 RK	R-5	Rural-5 Acre	Single Family Res-Combo
00 107381 RK	R-5	Rural-5 Acre	Single Family Res-Combo
01 105360 RK	R-5	Rural-5 Acre	Single Family Res-Combo
01 101588 RK	R-5	Rural-5 Acre	Single Family Res-Combo
01 104183 RK	R-5	Rural-5 Acre	Single Family Res-Combo
00 109914 RK	R-5	Rural-5 Acre	Single Family Res-Combo
01 103242 RK	R-5	Rural-5 Acre	Single Family Res-Combo
01 108059 RK	R-5	Rural-5 Acre	SFR-Basic
01 104153 RK	R-5	Rural-5 Acre	Single Family Res-Combo
01 100359 RK	R-5	Rural-5 Acre	Single Family Res-Combo
01 100285 RK	R-5	Rural-5 Acre	Single Family Res-Combo
01 104036 RK	R-5	Rural-5 Acre	Single Family Res-Combo
01 101392 RK	R-5	Rural-5 Acre	Single Family Res-Combo
01 104159 RK	R-5	Rural-5 Acre	Single Family Res-Combo
01 104157 RK	R-5	Rural-5 Acre	Single Family Res-Combo
01 101467 RK	R-5	Rural-5 Acre	Single Family Res-Combo
01 101957 RK	R-5	Rural-5 Acre	Single Family Res-Combo
01 103996 RK	R-5	Rural-5 Acre	Single Family Res-Combo
01 104158 RK	R-5	Rural-5 Acre	Single Family Res-Combo
01 105057 RK	R-5	Rural-5 Acre	Single Family Res-Combo
01 105669 RK	R-5	Rural-5 Acre	Single Family Res-Combo
01 100845 RK	R-9,600(PRD)	Residential 9,600 sq. ft.	SFR-Basic
01 100846 RK	R-9,600(PRD)	Residential 9,600 sq. ft.	SFR-Basic
01 100848 RK	R-9,600(PRD)	Residential 9,600 sq. ft.	SFR-Basic
01 101374 RK	R-9,600(PRD)	Residential 9,600 sq. ft.	Single Family Res-Combo
01 101495 RK	R-9,600(PRD)	Residential 9,600 sq. ft.	Single Family Res-Combo
01 104013 RK	R-9,600(PRD)	Residential 9,600 sq. ft.	SFR-Basic

Accessory Dwelling Units

Index # - File Name: 1.0022 - Single Family Dwellings Data\_Snohomish County.pdf

01 104816 RK	R-9,600(PRD)	Residential 9,600 sq. ft.	SFR-Basic
01 104815 RK	R-9,600(PRD)	Residential 9,600 sq. ft.	SFR-Basic
01 104818 RK	R-9,600(PRD)	Residential 9,600 sq. ft.	SFR-Basic
01 105213 RK	R-9,600(PRD)	Residential 9,600 sq. ft.	SFR-Basic
01 103814 RK	R-9,600(PRD)	Residential 9,600 sq. ft.	SFR-Basic
01 104817 RK	R-9,600(PRD)	Residential 9,600 sq. ft.	SFR-Basic
01 105218 RK	R-9,600(PRD)	Residential 9,600 sq. ft.	SFR-Basic
01 105432 RK	R-9,600(PRD)	Residential 9,600 sq. ft.	SFR-Basic
01 105433 RK	R-9,600(PRD)	Residential 9,600 sq. ft.	SFR-Basic
01 106029 RK	R-9,600(PRD)	Residential 9,600 sq. ft.	SFR-Basic
01 106030 RK	R-9,600(PRD)	Residential 9,600 sq. ft.	SFR-Basic
01 105785 RK	R-9,600(PRD)	Residential 9,600 sq. ft.	SFR-Basic
01 107684 RK	R-9,600(PRD)	Residential 9,600 sq. ft.	SFR-Basic
01 105788 RK	R-9,600(PRD)	Residential 9,600 sq. ft.	SFR-Basic
01 105215 RK	R-9,600(PRD)	Residential 9,600 sq. ft.	SFR-Basic
01 103815 RK	R-9,600(PRD)	Residential 9,600 sq. ft.	SFR-Basic
01 101494 RK	R-9,600(PRD)	Residential 9,600 sq. ft.	SFR-Basic
01 104524 RK	R-9,600(PRD)	Residential 9,600 sq. ft.	SFR-Basic
01 104238 RK	R-9,600(PRD)	Residential 9,600 sq. ft.	SFR-Basic
01 104234 RK	R-9,600(PRD)	Residential 9,600 sq. ft.	SFR-Basic
01 104239 RK	R-9,600(PRD)	Residential 9,600 sq. ft.	SFR-Basic
01 104012 RK	R-9,600(PRD)	Residential 9,600 sq. ft.	SFR-Basic
01 100029 RK	R-9,600(PRD)	Residential 9,600 sq. ft.	SFR-Basic
01 100030 RK	R-9,600(PRD)	Residential 9,600 sq. ft.	SFR-Basic
01 100031 RK	R-9,600(PRD)	Residential 9,600 sq. ft.	SFR-Basic
01 100168 RK	R-9,600(PRD)	Residential 9,600 sq. ft.	SFR-Basic
01 100169 RK	R-9,600(PRD)	Residential 9,600 sq. ft.	SFR-Basic
01 100167 RK	R-9,600(PRD)	Residential 9,600 sq. ft.	SFR-Basic
01 106028 RK	R-9,600(PRD)	Residential 9,600 sq. ft.	SFR-Basic
01 104525 RK	R-9,600(PRD)	Residential 9,600 sq. ft.	SFR-Basic
01 104240 RK	R-9,600(PRD)	Residential 9,600 sq. ft.	SFR-Basic
01 100393 RK	R-9,600(PRD)	Residential 9,600 sq. ft.	SFR-Basic
01 100558 RK	R-9,600(PRD)	Residential 9,600 sq. ft.	SFR-Basic
01 104241 RK	R-9,600(PRD)	Residential 9,600 sq. ft.	SFR-Basic
01 105649 RK	R-9,600(PRD)	Residential 9,600 sq. ft.	SFR-Basic
01 105650 RK	R-9,600(PRD)	Residential 9,600 sq. ft.	SFR-Basic
01 106949 RK	R-9,600(PRD)	Residential 9,600 sq. ft.	SFR-Basic
01 106951 RK	R-9,600(PRD)	Residential 9,600 sq. ft.	SFR-Basic
01 106950 RK	R-9,600(PRD)	Residential 9,600 sq. ft.	SFR-Basic
01 107077 RK	R-9,600(PRD)	Residential 9,600 sq. ft.	SFR-Basic
01 107076 RK	R-9,600(PRD)	Residential 9,600 sq. ft.	SFR-Basic
01 107290 RK	R-9,600(PRD)	Residential 9,600 sq. ft.	SFR-Basic
01 105430 RK	R-9,600(PRD)	Residential 9,600 sq. ft.	SFR-Basic
01 105429 RK	R-9,600(PRD)	Residential 9,600 sq. ft.	SFR-Basic
01 105431 RK	R-9,600(PRD)	Residential 9,600 sq. ft.	SFR-Basic
01 105219 RK	R-9,600(PRD)	Residential 9,600 sq. ft.	SFR-Basic
01 105217 RK	R-9,600(PRD)	Residential 9,600 sq. ft.	SFR-Basic

Accessory Dwelling Units

Index # - File Name: 1.0022 - Single Family Dwellings Data\_Snohomish County.pdf

01 104242 RK	R-9,600(PRD)	Residential 9,600 sq. ft.	SFR-Basic
01 103382 RK	R-9,600(PRD)	Residential 9,600 sq. ft.	SFR-Basic
01 101372 RK	R-9,600(PRD)	Residential 9,600 sq. ft.	SFR-Basic
01 101760 RK	R-9,600(PRD)	Residential 9,600 sq. ft.	SFR-Basic
01 101758 RK	R-9,600(PRD)	Residential 9,600 sq. ft.	SFR-Basic
01 100561 RK	R-9,600(PRD)	Residential 9,600 sq. ft.	SFR-Basic
01 100562 RK	R-9,600(PRD)	Residential 9,600 sq. ft.	SFR-Basic
01 100563 RK	R-9,600(PRD)	Residential 9,600 sq. ft.	SFR-Basic
01 100564 RK	R-9,600(PRD)	Residential 9,600 sq. ft.	SFR-Basic
01 100560 RK	R-9,600(PRD)	Residential 9,600 sq. ft.	SFR-Basic
01 111248 RK	R-9,600(PRD)	Residential 9,600 sq. ft.	SFR-Basic
01 107425 RK	R-5	Rural-5 Acre	Single Family Res-Combo
01 103520 RK	R-9,600(PRD)	Residential 9,600 sq. ft.	SFR-Basic
01 103517 RK	R-9,600(PRD)	Residential 9,600 sq. ft.	SFR-Basic
01 110913 RK	R-9,600(PRD)	Residential 9,600 sq. ft.	SFR-Basic
01 103518 RK	R-9,600(PRD)	Residential 9,600 sq. ft.	SFR-Basic
01 103522 RK	R-9,600(PRD)	Residential 9,600 sq. ft.	SFR-Basic
01 110915 RK	R-9,600(PRD)	Residential 9,600 sq. ft.	SFR-Basic
01 103503 RK	R-9,600(PRD)	Residential 9,600 sq. ft.	SFR-Basic
01 103504 RK	R-9,600(PRD)	Residential 9,600 sq. ft.	SFR-Basic
01 101722 RK	R-9,600(PRD)	Residential 9,600 sq. ft.	SFR-Basic
01 110920 RK	R-9,600(PRD)	Residential 9,600 sq. ft.	SFR-Basic
01 110921 RK	R-9,600(PRD)	Residential 9,600 sq. ft.	SFR-Basic
01 103361 RK	R-9,600(PRD)	Residential 9,600 sq. ft.	SFR-Basic
01 110922 RK	R-9,600(PRD)	Residential 9,600 sq. ft.	SFR-Basic
01 103365 RK	R-9,600(PRD)	Residential 9,600 sq. ft.	SFR-Basic
01 103360 RK	R-9,600(PRD)	Residential 9,600 sq. ft.	SFR-Basic
01 105471 RK	R-9,600(PRD)	Residential 9,600 sq. ft.	SFR-Basic
01 103519 RK	R-9,600(PRD)	Residential 9,600 sq. ft.	SFR-Basic
01 103364 RK	R-9,600(PRD)	Residential 9,600 sq. ft.	SFR-Basic
01 103366 RK	R-9,600(PRD)	Residential 9,600 sq. ft.	SFR-Basic
01 103362 RK	R-9,600(PRD)	Residential 9,600 sq. ft.	SFR-Basic
01 103368 RK	R-9,600(PRD)	Residential 9,600 sq. ft.	SFR-Basic
01 103363 RK	R-9,600(PRD)	Residential 9,600 sq. ft.	SFR-Basic
01 103367 RK	R-9,600(PRD)	Residential 9,600 sq. ft.	SFR-Basic
01 104872 RK	R-5	Rural-5 Acre	Single Family Res-Combo
01 100401 RK	R-5	Rural-5 Acre	Single Family Res-Combo
01 100495 RK	R-5	Rural-5 Acre	Single Family Res-Combo
01 106278 RK	R-5	Rural-5 Acre	SFR-Basic
01 106500 RK	R-5	Rural-5 Acre	Single Family Res-Combo
01 106279 RK	R-5	Rural-5 Acre	SFR-Basic
01 107609 RK	R-5	Rural-5 Acre	Single Family Res-Combo
01 100996 RK	R-5	Rural-5 Acre	Single Family Res-Combo
01 105507 RK	R-5	Rural-5 Acre	Single Family Res-Combo
01 104799 RK	R-5	Rural-5 Acre	Single Family Res-Combo
01 106313 RK	R-5	Rural-5 Acre	Single Family Res-Combo
01 105678 RK	R-5	Rural-5 Acre	Single Family Res-Combo

Accessory Dwelling Units

Index # - File Name: 1.0022 - Single Family Dwellings Data\_Snohomish County.pdf

01 111683 RK	R-5	Rural-5 Acre	Single Family Res-Combo
01 101093 RK	R-5	Rural-5 Acre	Single Family Res-Combo
01 104733 RK	R-5	Rural-5 Acre	Single Family Res-Combo
01 106984 RK	PRD-7,200	Residential 7,200 sq. ft.	Single Family Res-Combo
01 111226 RK	PRD-7,200	Residential 7,200 sq. ft.	SFR-Basic
01 111303 RK	PRD-7,200	Residential 7,200 sq. ft.	SFR-Basic
01 107782 RK	PRD-7,200	Residential 7,200 sq. ft.	SFR-Basic
01 108237 RK	PRD-7,200	Residential 7,200 sq. ft.	SFR-Basic
01 111691 RK	PRD-7,200	Residential 7,200 sq. ft.	SFR-Basic
01 106841 RK	PRD-7,200	Residential 7,200 sq. ft.	SFR-Basic
01 108236 RK	PRD-7,200	Residential 7,200 sq. ft.	SFR-Basic
01 107152 RK	PRD-7,200	Residential 7,200 sq. ft.	SFR-Basic
01 110583 RK	PRD-7,200	Residential 7,200 sq. ft.	SFR-Basic
01 107776 RK	PRD-7,200	Residential 7,200 sq. ft.	SFR-Basic
01 106840 RK	PRD-7,200	Residential 7,200 sq. ft.	SFR-Basic
01 107660 RK	PRD-7,200	Residential 7,200 sq. ft.	SFR-Basic
01 107156 RK	PRD-7,200	Residential 7,200 sq. ft.	SFR-Basic
01 107661 RK	PRD-7,200	Residential 7,200 sq. ft.	SFR-Basic
01 103245 RK	PRD-7,200	Residential 7,200 sq. ft.	SFR-Basic
01 104628 RK	PRD-7,200	Residential 7,200 sq. ft.	Single Family Res-Combo
01 103246 RK	PRD-7,200	Residential 7,200 sq. ft.	SFR-Basic
01 103462 RK	PRD-7,200	Residential 7,200 sq. ft.	SFR-Basic
01 105535 RK	PRD-7,200	Residential 7,200 sq. ft.	SFR-Basic
01 105534 RK	PRD-7,200	Residential 7,200 sq. ft.	SFR-Basic
01 107011 RK	PRD-7,200	Residential 7,200 sq. ft.	SFR-Basic
01 105132 RK	PRD-7,200	Residential 7,200 sq. ft.	SFR-Basic
01 104626 RK	PRD-7,200	Residential 7,200 sq. ft.	SFR-Basic
01 103758 RK	PRD-7,200	Residential 7,200 sq. ft.	SFR-Basic
01 103464 RK	PRD-7,200	Residential 7,200 sq. ft.	SFR-Basic
01 105732 RK	PRD-7,200	Residential 7,200 sq. ft.	SFR-Basic
01 105733 RK	PRD-7,200	Residential 7,200 sq. ft.	SFR-Basic
01 105731 RK	PRD-7,200	Residential 7,200 sq. ft.	SFR-Basic
01 103243 RK	PRD-7,200	Residential 7,200 sq. ft.	SFR-Basic
01 107777 RK	PRD-7,200	Residential 7,200 sq. ft.	SFR-Basic
01 105655 RK	PRD-7,200	Residential 7,200 sq. ft.	SFR-Basic
01 107013 RK	PRD-7,200	Residential 7,200 sq. ft.	Single Family Res-Combo
01 106472 RK	PRD-7,200	Residential 7,200 sq. ft.	SFR-Basic
01 103757 RK	PRD-7,200	Residential 7,200 sq. ft.	SFR-Basic
01 103461 RK	PRD-7,200	Residential 7,200 sq. ft.	SFR-Basic
01 103463 RK	PRD-7,200	Residential 7,200 sq. ft.	SFR-Basic
01 103244 RK	PRD-7,200	Residential 7,200 sq. ft.	SFR-Basic
01 110584 RK	PRD-7,200	Residential 7,200 sq. ft.	SFR-Basic
01 105536 RK	PRD-7,200	Residential 7,200 sq. ft.	SFR-Basic
01 107010 RK	PRD-7,200	Residential 7,200 sq. ft.	SFR-Basic
01 104625 RK	PRD-7,200	Residential 7,200 sq. ft.	SFR-Basic
01 107149 RK	PRD-7,200	Residential 7,200 sq. ft.	SFR-Basic
01 106842 RK	PRD-7,200	Residential 7,200 sq. ft.	SFR-Basic



Accessory Dwelling Units

Index # - File Name: 1.0022 - Single Family Dwellings Data\_Snohomish County.pdf

01 110764 RK	PRD-7,200	Residential 7,200 sq. ft.	SFR-Basic
01 108238 RK	PRD-7,200	Residential 7,200 sq. ft.	SFR-Basic
01 107662 RK	PRD-7,200	Residential 7,200 sq. ft.	SFR-Basic
01 107150 RK	PRD-7,200	Residential 7,200 sq. ft.	SFR-Basic
01 106839 RK	PRD-7,200	Residential 7,200 sq. ft.	SFR-Basic
01 100671 RK	R-5	Rural-5 Acre	SFR-Basic
01 101745 RK	R-5	Rural-5 Acre	Single Family Res-Combo
01 104570 RK	R-5	Rural-5 Acre	Single Family Res-Combo
01 100672 RK	R-5	Rural-5 Acre	SFR-Basic
01 100673 RK	R-5	Rural-5 Acre	SFR-Basic
01 101248 RK	R-5	Rural-5 Acre	SFR-Basic
01 101896 RK	R-5	Rural-5 Acre	Single Family Res-Combo
01 101341 RK	R-5	Rural-5 Acre	Single Family Res-Combo
01 101765 RK	R-5	Rural-5 Acre	Single Family Res-Combo
01 103835 RK	R-5	Rural-5 Acre	SFR-Basic
01 101404 RK	R-5	Rural-5 Acre	Single Family Res-Combo
01 103188 RK	R-5	Rural-5 Acre	Single Family Res-Combo
01 103186 RK	R-5	Rural-5 Acre	Single Family Res-Combo
01 104414 RK	R-5	Rural-5 Acre	Single Family Res-Combo
01 104341 RK	R-5	Rural-5 Acre	SFR-Basic
01 100799 RK	R-7,200	Residential 7,200 sq. ft.	SFR-Basic
01 100753 RK	R-7,200	Residential 7,200 sq. ft.	SFR-Basic
01 100752 RK	R-7,200	Residential 7,200 sq. ft.	SFR-Basic
01 100833 MH	RC	Rural Conservation	Double Wide
01 100842 RK	R-7,200 : R-7,2	Residential 7,200 sq. ft. : Res	Single Family Res-Combo
01 103474 RK	R-7,200	Residential 7,200 sq. ft.	Single Family Res-Combo
01 100823 RK	R-7,200	Residential 7,200 sq. ft.	SFR-Basic
01 100825 RK	R-7,200	Residential 7,200 sq. ft.	SFR-Basic
00 111060 RK	R-7,200	Residential 7,200 sq. ft.	Single Family Res-Combo
01 100148 RK	R-7,200	Residential 7,200 sq. ft.	Single Family Res-Combo
01 101245 RK	R-7,200	Residential 7,200 sq. ft.	SFR-Basic
01 101246 RK	R-7,200	Residential 7,200 sq. ft.	SFR-Basic
01 104041 RK	R-7,200	Residential 7,200 sq. ft.	SFR-Basic
01 101512 RK	R-7,200	Residential 7,200 sq. ft.	SFR-Basic
00 109147 RK	R-7,200	Residential 7,200 sq. ft.	Single Family Res-Combo
01 101513 RK	R-7,200	Residential 7,200 sq. ft.	SFR-Basic
01 103478 RK	R-7,200	Residential 7,200 sq. ft.	SFR-Basic
01 104635 RK	R-7,200	Residential 7,200 sq. ft.	SFR-Basic
01 104040 RK	R-7,200	Residential 7,200 sq. ft.	SFR-Basic
01 107352 RK	R-7,200	Residential 7,200 sq. ft.	SFR-Basic
01 106998 RK	R-7,200	Residential 7,200 sq. ft.	SFR-Basic
01 104634 RK	R-7,200	Residential 7,200 sq. ft.	SFR-Basic
01 106514 RK	R-7,200	Residential 7,200 sq. ft.	SFR-Basic
01 106588 RK	R-7,200	Residential 7,200 sq. ft.	SFR-Basic
01 100827 RK	R-7,200	Residential 7,200 sq. ft.	SFR-Basic
01 100145 RK	R-7,200	Residential 7,200 sq. ft.	Single Family Res-Combo
00 110005 RK	R-7,200	Residential 7,200 sq. ft.	Single Family Res-Combo

Accessory Dwelling Units

Index # - File Name: 1.0022 - Single Family Dwellings Data\_Snohomish County.pdf

01 111587 RK	R-9,600	Residential 9,600 sq. ft.	SFR-Basic
01 111491 RK	R-9,600	Residential 9,600 sq. ft.	SFR-Basic
01 112100 RK	R-9,600	Residential 9,600 sq. ft.	SFR-Basic
01 112101 RK	R-9,600	Residential 9,600 sq. ft.	Single Family Res-Combo
01 100957 RK	R-5	Rural-5 Acre	Single Family Res-Combo
01 105401 RK	PRD-9,600	Residential 9,600 sq. ft.	SFR-Basic
01 105411 RK	PRD-9,600	Residential 9,600 sq. ft.	SFR-Basic
01 105402 RK	PRD-9,600	Residential 9,600 sq. ft.	SFR-Basic
01 107373 RK	PRD-9,600	Residential 9,600 sq. ft.	SFR-Basic
01 105406 RK	PRD-9,600	Residential 9,600 sq. ft.	SFR-Basic
01 105407 RK	PRD-9,600	Residential 9,600 sq. ft.	SFR-Basic
01 105412 RK	PRD-9,600	Residential 9,600 sq. ft.	SFR-Basic
01 105403 RK	PRD-9,600	Residential 9,600 sq. ft.	SFR-Basic
01 103425 RK	PRD-9,600	Residential 9,600 sq. ft.	Single Family Res-Combo
01 103424 RK	PRD-9,600	Residential 9,600 sq. ft.	Single Family Res-Combo
01 107374 RK	PRD-9,600	Residential 9,600 sq. ft.	SFR-Basic
01 103422 RK	PRD-9,600	Residential 9,600 sq. ft.	Single Family Res-Combo
01 106057 RK	R-9,600	Residential 9,600 sq. ft.	Single Family Res-Combo
01 106054 RK	R-9,600	Residential 9,600 sq. ft.	Single Family Res-Combo
01 105354 RK	R-7,200	Residential 7,200 sq. ft.	Single Family Res-Combo
01 105350 RK	R-7,200	Residential 7,200 sq. ft.	Single Family Res-Combo
01 101445 RK	CITY	City	SFR-Basic
01 103803 RK	CITY	City	SFR-Basic
01 101448 RK	CITY	City	SFR-Basic
01 101440 RK	CITY	City	SFR-Basic
01 103804 RK	CITY	City	SFR-Basic
01 103805 RK	CITY	City	SFR-Basic
01 103843 RK	CITY	City	SFR-Basic
01 103527 RK	CITY	City	SFR-Basic
01 103525 RK	CITY	City	SFR-Basic
01 103806 RK	CITY	City	SFR-Basic
01 101443 RK	CITY	City	SFR-Basic
01 101442 RK	CITY	City	SFR-Basic
01 101447 RK	CITY	City	SFR-Basic
01 101446 RK	CITY	City	SFR-Basic
01 101449 RK	CITY	City	SFR-Basic
01 101450 RK	CITY	City	SFR-Basic
01 111664 RK	CITY	City	SFR-Basic
01 111665 RK	CITY	City	SFR-Basic
01 111667 RK	CITY	City	SFR-Basic
01 111668 RK	CITY	City	SFR-Basic
01 111669 RK	CITY	City	SFR-Basic
01 111670 RK	CITY	City	SFR-Basic
01 111671 RK	CITY	City	SFR-Basic
01 111673 RK	CITY	City	SFR-Basic
01 103845 RK	CITY	City	SFR-Basic
01 105967 RK	CITY	City	SFR-Basic

Accessory Dwelling Units

Index # - File Name: 1.0022 - Single Family Dwellings Data\_Snohomish County.pdf

01 105965 RK	CITY	City	SFR-Basic
01 111157 RK	CITY	City	SFR-Basic
01 111158 RK	CITY	City	SFR-Basic
01 111678 RK	CITY	City	SFR-Basic
01 111159 RK	CITY	City	SFR-Basic
01 111160 RK	CITY	City	SFR-Basic
01 111679 RK	CITY	City	SFR-Basic
01 111156 RK	CITY	City	SFR-Basic
01 106780 RK	CITY	City	SFR-Basic
01 106779 RK	CITY	City	SFR-Basic
01 106778 RK	CITY	City	SFR-Basic
01 106777 RK	CITY	City	SFR-Basic
01 106776 RK	CITY	City	SFR-Basic
01 106775 RK	CITY	City	SFR-Basic
01 106773 RK	CITY	City	SFR-Basic
01 106772 RK	CITY	City	SFR-Basic
01 106769 RK	CITY	City	SFR-Basic
01 106768 RK	CITY	City	SFR-Basic
01 105968 RK	CITY	City	SFR-Basic
01 106686 RK	CITY	City	SFR-Basic
01 101349 RK	PRD-8,400	Residential 8,400 sq. ft.	SFR-Basic
01 101348 RK	PRD-8,400	Residential 8,400 sq. ft.	SFR-Basic
01 101945 RK	PRD-8,400	Residential 8,400 sq. ft.	SFR-Basic
01 101943 RK	PRD-8,400	Residential 8,400 sq. ft.	SFR-Basic
01 101346 RK	PRD-8,400	Residential 8,400 sq. ft.	SFR-Basic
01 101351 RK	PRD-8,400	Residential 8,400 sq. ft.	SFR-Basic
01 105946 RK	PRD-8,400	Residential 8,400 sq. ft.	SFR-Basic
01 104045 RK	PRD-8,400	Residential 8,400 sq. ft.	Single Family Res-Combo
01 105479 RK	PRD-8,400	Residential 8,400 sq. ft.	SFR-Basic
01 105480 RK	PRD-8,400	Residential 8,400 sq. ft.	SFR-Basic
00 109401 RK	PRD-8,400	Residential 8,400 sq. ft.	Single Family Res-Combo
01 103310 RK	PRD-8,400	Residential 8,400 sq. ft.	SFR-Basic
01 101942 RK	PRD-8,400	Residential 8,400 sq. ft.	SFR-Basic
01 106687 RK	PRD-8,400	Residential 8,400 sq. ft.	SFR-Basic
01 104473 RK	PRD-8,400	Residential 8,400 sq. ft.	SFR-Basic
01 104475 RK	PRD-8,400	Residential 8,400 sq. ft.	SFR-Basic
01 101345 RK	PRD-8,400	Residential 8,400 sq. ft.	SFR-Basic
01 104892 RK	PRD-8,400	Residential 8,400 sq. ft.	SFR-Basic
01 104896 RK	PRD-8,400	Residential 8,400 sq. ft.	SFR-Basic
01 101946 RK	PRD-8,400	Residential 8,400 sq. ft.	SFR-Basic
01 104889 RK	PRD-8,400	Residential 8,400 sq. ft.	SFR-Basic
01 104893 RK	PRD-8,400	Residential 8,400 sq. ft.	SFR-Basic
01 106685 RK	PRD-8,400	Residential 8,400 sq. ft.	SFR-Basic
01 104474 RK	PRD-8,400	Residential 8,400 sq. ft.	SFR-Basic
01 105305 RK	PRD-8,400	Residential 8,400 sq. ft.	SFR-Basic
01 101347 RK	PRD-8,400	Residential 8,400 sq. ft.	SFR-Basic
01 103844 RK	CITY	City	SFR-Basic

Accessory Dwelling Units

Index # - File Name: 1.0022 - Single Family Dwellings Data\_Snohomish County.pdf

01 105969 RK	CITY	City	SFR-Basic
01 105966 RK	CITY	City	SFR-Basic
01 105971 RK	CITY	City	SFR-Basic
01 103846 RK	CITY	City	SFR-Basic
01 103849 RK	CITY	City	SFR-Basic
01 103521 RK	CITY	City	SFR-Basic
01 103807 RK	CITY	City	SFR-Basic
01 101393 RK	CITY	City	Single Family Res-Combo
01 101395 RK	CITY	City	Single Family Res-Combo
01 101555 RK	RRT-10	Rural Resource Transition-10	Single Family Res-Combo
01 101498 MH	MHP	Mobile Home Park	MH Park-Double Wide
00 107793 MH	R-5	Rural-5 Acre	Double Wide
01 111019 RK	PRD-7,200	Residential 7,200 sq. ft.	SFR-Basic
01 106290 RK	PRD-7,200	Residential 7,200 sq. ft.	SFR-Basic
01 104968 RK	PRD-7,200	Residential 7,200 sq. ft.	SFR-Basic
01 105522 RK	PRD-7,200	Residential 7,200 sq. ft.	SFR-Basic
01 104742 RK	PRD-7,200	Residential 7,200 sq. ft.	Single Family Res-Combo
01 104965 RK	PRD-7,200	Residential 7,200 sq. ft.	SFR-Basic
01 111023 RK	PRD-7,200	Residential 7,200 sq. ft.	SFR-Basic
01 107453 RK	PRD-7,200	Residential 7,200 sq. ft.	Single Family Res-Combo
01 111024 RK	PRD-7,200	Residential 7,200 sq. ft.	SFR-Basic
01 107268 RK	PRD-7,200	Residential 7,200 sq. ft.	Single Family Res-Combo
01 104963 RK	PRD-7,200	Residential 7,200 sq. ft.	SFR-Basic
01 107133 RK	PRD-7,200	Residential 7,200 sq. ft.	SFR-Basic
01 107134 RK	PRD-7,200	Residential 7,200 sq. ft.	SFR-Basic
01 104962 RK	PRD-7,200	Residential 7,200 sq. ft.	SFR-Basic
01 104964 RK	PRD-7,200	Residential 7,200 sq. ft.	SFR-Basic
01 104959 RK	PRD-7,200	Residential 7,200 sq. ft.	SFR-Basic
01 107132 RK	PRD-7,200	Residential 7,200 sq. ft.	SFR-Basic
01 107135 RK	PRD-7,200	Residential 7,200 sq. ft.	SFR-Basic
01 101596 RK	R-9,600	Residential 9,600 sq. ft.	Single Family Res-Combo
01 104969 RK	PRD-7,200	Residential 7,200 sq. ft.	SFR-Basic
01 104976 RK	PRD-7,200	Residential 7,200 sq. ft.	SFR-Basic
01 104977 RK	PRD-7,200	Residential 7,200 sq. ft.	SFR-Basic
01 105908 RK	PRD-7,200	Residential 7,200 sq. ft.	SFR-Basic
00 109210 RK	PRD-7,200	Residential 7,200 sq. ft.	Single Family Res-Combo
01 104741 RK	PRD-7,200	Residential 7,200 sq. ft.	Single Family Res-Combo
01 104960 RK	PRD-7,200	Residential 7,200 sq. ft.	SFR-Basic
01 104973 RK	PRD-7,200	Residential 7,200 sq. ft.	SFR-Basic
01 106489 RK	PRD-7,200	Residential 7,200 sq. ft.	SFR-Basic
01 104966 RK	PRD-7,200	Residential 7,200 sq. ft.	SFR-Basic
01 104961 RK	PRD-7,200	Residential 7,200 sq. ft.	SFR-Basic
01 104970 RK	PRD-7,200	Residential 7,200 sq. ft.	SFR-Basic
01 104974 RK	PRD-7,200	Residential 7,200 sq. ft.	SFR-Basic
01 105523 RK	PRD-7,200	Residential 7,200 sq. ft.	SFR-Basic
01 105938 RK	PRD-9,600	Residential 9,600 sq. ft.	SFR-Basic
01 107231 RK	PRD-9,600	Residential 9,600 sq. ft.	SFR-Basic

Accessory Dwelling Units

Index # - File Name: 1.0022 - Single Family Dwellings Data\_Snohomish County.pdf

01 104681 RK	PRD-9,600	Residential 9,600 sq. ft.	SFR-Basic
01 106837 RK	PRD-9,600	Residential 9,600 sq. ft.	SFR-Basic
01 106836 RK	PRD-9,600	Residential 9,600 sq. ft.	SFR-Basic
01 104532 RK	PRD-9,600	Residential 9,600 sq. ft.	Single Family Res-Combo
01 104134 RK	PRD-9,600	Residential 9,600 sq. ft.	Single Family Res-Combo
01 105939 RK	PRD-9,600	Residential 9,600 sq. ft.	Single Family Res-Combo
01 106326 RK	PRD-9,600	Residential 9,600 sq. ft.	SFR-Basic
01 103251 RK	PRD-9,600	Residential 9,600 sq. ft.	Single Family Res-Combo
01 103252 RK	PRD-9,600	Residential 9,600 sq. ft.	Single Family Res-Combo
01 101338 RK	PRD-9,600	Residential 9,600 sq. ft.	Single Family Res-Combo
01 101337 RK	PRD-9,600	Residential 9,600 sq. ft.	Single Family Res-Combo
01 101340 RK	PRD-9,600	Residential 9,600 sq. ft.	Single Family Res-Combo
01 104904 RK	PRD-9,600	Residential 9,600 sq. ft.	SFR-Basic
01 105940 RK	PRD-9,600	Residential 9,600 sq. ft.	Single Family Res-Combo
01 106497 RK	PRD-9,600	Residential 9,600 sq. ft.	SFR-Basic
01 106496 RK	PRD-9,600	Residential 9,600 sq. ft.	SFR-Basic
01 106498 RK	PRD-9,600	Residential 9,600 sq. ft.	SFR-Basic
01 106826 RK	PRD-9,600	Residential 9,600 sq. ft.	SFR-Basic
01 106823 RK	PRD-9,600	Residential 9,600 sq. ft.	SFR-Basic
01 106494 RK	PRD-9,600	Residential 9,600 sq. ft.	SFR-Basic
01 107779 RK	PRD-9,600	Residential 9,600 sq. ft.	SFR-Basic
01 104679 RK	PRD-9,600	Residential 9,600 sq. ft.	SFR-Basic
01 104683 RK	PRD-9,600	Residential 9,600 sq. ft.	SFR-Basic
01 104680 RK	PRD-9,600	Residential 9,600 sq. ft.	SFR-Basic
01 105696 RK	R-5	Rural-5 Acre	Single Family Res-Combo
01 103253 RK	PRD-7,200	Residential 7,200 sq. ft.	Single Family Res-Combo
01 103152 RK	PRD-7,200	Residential 7,200 sq. ft.	SFR-Basic
01 105571 RK	PRD-7,200	Residential 7,200 sq. ft.	SFR-Basic
01 103144 RK	PRD-7,200	Residential 7,200 sq. ft.	SFR-Basic
01 103149 RK	PRD-7,200	Residential 7,200 sq. ft.	SFR-Basic
01 103147 RK	PRD-7,200	Residential 7,200 sq. ft.	SFR-Basic
01 104677 RK	PRD-7,200	Residential 7,200 sq. ft.	Single Family Res-Combo
01 103153 RK	PRD-7,200	Residential 7,200 sq. ft.	SFR-Basic
01 104804 RK	PRD-7,200	Residential 7,200 sq. ft.	SFR-Basic
01 104808 RK	PRD-7,200	Residential 7,200 sq. ft.	SFR-Basic
01 103150 RK	PRD-7,200	Residential 7,200 sq. ft.	SFR-Basic
01 103148 RK	PRD-7,200	Residential 7,200 sq. ft.	SFR-Basic
01 103151 RK	PRD-7,200	Residential 7,200 sq. ft.	SFR-Basic
01 103146 RK	PRD-7,200	Residential 7,200 sq. ft.	SFR-Basic
01 103145 RK	PRD-7,200	Residential 7,200 sq. ft.	SFR-Basic
01 105572 RK	PRD-7,200	Residential 7,200 sq. ft.	SFR-Basic
01 104800 RK	PRD-7,200	Residential 7,200 sq. ft.	SFR-Basic
01 104805 RK	PRD-7,200	Residential 7,200 sq. ft.	SFR-Basic
01 104801 RK	PRD-7,200	Residential 7,200 sq. ft.	SFR-Basic
01 104806 RK	PRD-7,200	Residential 7,200 sq. ft.	SFR-Basic
01 104802 RK	PRD-7,200	Residential 7,200 sq. ft.	SFR-Basic
01 104807 RK	PRD-7,200	Residential 7,200 sq. ft.	SFR-Basic

Accessory Dwelling Units

Index # - File Name: 1.0022 - Single Family Dwellings Data\_Snohomish County.pdf

01 104803 RK	PRD-7,200	Residential 7,200 sq. ft.	SFR-Basic
01 101369 RK	PRD-7,200	Residential 7,200 sq. ft.	Single Family Res-Combo
01 103408 RK	PRD-7,200	Residential 7,200 sq. ft.	SFR-Basic
01 107110 RK	PRD-7,200	Residential 7,200 sq. ft.	SFR-Basic
01 103410 RK	PRD-7,200	Residential 7,200 sq. ft.	SFR-Basic
01 103411 RK	PRD-7,200	Residential 7,200 sq. ft.	SFR-Basic
01 105683 RK	PRD-7,200	Residential 7,200 sq. ft.	SFR-Basic
01 103412 RK	PRD-7,200	Residential 7,200 sq. ft.	SFR-Basic
01 105685 RK	PRD-7,200	Residential 7,200 sq. ft.	SFR-Basic
01 107112 RK	PRD-7,200	Residential 7,200 sq. ft.	SFR-Basic
01 103413 RK	PRD-7,200	Residential 7,200 sq. ft.	SFR-Basic
01 107113 RK	PRD-7,200	Residential 7,200 sq. ft.	SFR-Basic
01 103414 RK	PRD-7,200	Residential 7,200 sq. ft.	SFR-Basic
01 104203 RK	PRD-7,200	Residential 7,200 sq. ft.	Single Family Res-Combo
01 103415 RK	PRD-7,200	Residential 7,200 sq. ft.	SFR-Basic
01 107114 RK	PRD-7,200	Residential 7,200 sq. ft.	SFR-Basic
01 103416 RK	PRD-7,200	Residential 7,200 sq. ft.	SFR-Basic
01 105573 RK	PRD-7,200	Residential 7,200 sq. ft.	SFR-Basic
01 105574 RK	PRD-7,200	Residential 7,200 sq. ft.	SFR-Basic
01 105575 RK	PRD-7,200	Residential 7,200 sq. ft.	SFR-Basic
01 105315 RK	PRD-7,200	Residential 7,200 sq. ft.	Single Family Res-Combo
01 107309 RK	PRD-7,200	Residential 7,200 sq. ft.	SFR-Basic
01 107314 RK	PRD-7,200	Residential 7,200 sq. ft.	SFR-Basic
01 105044 RK	PRD-7,200	Residential 7,200 sq. ft.	SFR-Basic
01 101884 RK	PRD-7,200	Residential 7,200 sq. ft.	Single Family Res-Combo
01 101887 RK	PRD-7,200	Residential 7,200 sq. ft.	Single Family Res-Combo
01 107875 RK	PRD-7,200	Residential 7,200 sq. ft.	SFR-Basic
01 107876 RK	PRD-7,200	Residential 7,200 sq. ft.	SFR-Basic
01 110898 RK	PRD-7,200	Residential 7,200 sq. ft.	SFR-Basic
01 111022 RK	PRD-7,200	Residential 7,200 sq. ft.	SFR-Basic
01 111026 RK	PRD-7,200	Residential 7,200 sq. ft.	SFR-Basic
01 107111 RK	PRD-7,200	Residential 7,200 sq. ft.	SFR-Basic
01 104427 RK	R-5	Rural-5 Acre	Single Family Res-Combo
01 104926 RK	R-5	Rural-5 Acre	Single Family Res-Combo
01 106947 RK	R-5	Rural-5 Acre	SFR-Basic
01 106946 RK	R-5	Rural-5 Acre	SFR-Basic
01 107087 RK	R-5	Rural-5 Acre	Single Family Res-Combo
01 105335 RK	R-5	Rural-5 Acre	Single Family Res-Combo
00 108610 RK	R-5	Rural-5 Acre	Single Family Res-Combo
01 105336 RK	R-5	Rural-5 Acre	SFR-Basic
01 105338 RK	R-5	Rural-5 Acre	Single Family Res-Combo
01 111182 RK	R-5	Rural-5 Acre	Single Family Res-Combo
01 105339 RK	R-5	Rural-5 Acre	SFR-Basic
01 103936 RK	R-7,200	Residential 7,200 sq. ft.	SFR-Basic
01 103941 RK	R-7,200	Residential 7,200 sq. ft.	SFR-Basic
01 103939 RK	R-7,200	Residential 7,200 sq. ft.	SFR-Basic
01 103943 RK	R-7,200	Residential 7,200 sq. ft.	SFR-Basic

Accessory Dwelling Units

Index # - File Name: 1.0022 - Single Family Dwellings Data\_Snohomish County.pdf

01 103940 RK	R-7,200	Residential 7,200 sq. ft.	SFR-Basic
01 107100 RK	R-5	Rural-5 Acre	Single Family Res-Combo
01 104764 RK	R-5	Rural-5 Acre	Single Family Res-Combo
01 104923 RK	R-5	Rural-5 Acre	Single Family Res-Combo
01 103311 RK	CITY	City	SFR-Basic
01 103312 RK	CITY	City	SFR-Basic
00 108889 RK	R-5	Rural-5 Acre	Single Family Res-Combo
01 100629 RK	R-8,400	Residential 8,400 sq. ft.	Single Family Res-Combo
01 101021 RK	R-8,400	Residential 8,400 sq. ft.	Single Family Res-Combo
01 101064 RK	R-8,400	Residential 8,400 sq. ft.	Single Family Res-Combo
01 104359 RK	R-8,400	Residential 8,400 sq. ft.	SFR-Basic
01 101025 RK	R-8,400	Residential 8,400 sq. ft.	Single Family Res-Combo
01 104365 RK	R-8,400	Residential 8,400 sq. ft.	SFR-Basic
01 105090 RK	R-8,400	Residential 8,400 sq. ft.	SFR-Basic
01 111496 RK	R-8,400	Residential 8,400 sq. ft.	SFR-Basic
01 107865 RK	R-8,400	Residential 8,400 sq. ft.	SFR-Basic
01 107867 RK	R-8,400	Residential 8,400 sq. ft.	SFR-Basic
01 101023 RK	R-8,400	Residential 8,400 sq. ft.	Single Family Res-Combo
01 105869 RK	R-8,400	Residential 8,400 sq. ft.	SFR-Basic
01 105849 RK	R-8,400	Residential 8,400 sq. ft.	SFR-Basic
01 105867 RK	R-8,400	Residential 8,400 sq. ft.	SFR-Basic
01 111013 RK	R-8,400	Residential 8,400 sq. ft.	SFR-Basic
01 107040 RK	R-8,400	Residential 8,400 sq. ft.	Single Family Res-Combo
01 104944 RK	R-8,400	Residential 8,400 sq. ft.	SFR-Basic
01 101065 RK	R-8,400	Residential 8,400 sq. ft.	Single Family Res-Combo
01 104368 RK	R-8,400	Residential 8,400 sq. ft.	SFR-Basic
01 104357 RK	R-8,400	Residential 8,400 sq. ft.	SFR-Basic
01 105850 RK	R-8,400	Residential 8,400 sq. ft.	SFR-Basic
01 103158 RK	CITY	City	Single Family Res-Combo
01 107178 RK	R-7,200	Residential 7,200 sq. ft.	Single Family Res-Combo
01 103828 RK	PRD-9,600	Residential 9,600 sq. ft.	SFR-Basic
01 103831 RK	PRD-9,600	Residential 9,600 sq. ft.	SFR-Basic
01 103825 RK	PRD-9,600	Residential 9,600 sq. ft.	SFR-Basic
01 103834 RK	PRD-9,600	Residential 9,600 sq. ft.	SFR-Basic
01 103829 RK	PRD-9,600	Residential 9,600 sq. ft.	SFR-Basic
01 103832 RK	PRD-9,600	Residential 9,600 sq. ft.	SFR-Basic
01 111929 RK	R-5	Rural-5 Acre	SFR-Basic
99 110483 RK	A-10	Agriculture-10 Acre	Single Family Res-Combo
01 104782 RK	R-9,600	Residential 9,600 sq. ft.	Single Family Res-Combo
01 103980 RK	R-5	Rural-5 Acre	Single Family Res-Combo
01 105006 RK	R-9,600	Residential 9,600 sq. ft.	SFR-Basic
00 110897 RK	R-9,600	Residential 9,600 sq. ft.	Single Family Res-Combo
01 104791 RK	R-9,600	Residential 9,600 sq. ft.	SFR-Basic
01 104783 RK	R-9,600	Residential 9,600 sq. ft.	Single Family Res-Combo
01 105003 RK	R-9,600	Residential 9,600 sq. ft.	Single Family Res-Combo
01 104147 RK	R-9,600	Residential 9,600 sq. ft.	Single Family Res-Combo
00 110445 RK	R-9,600	Residential 9,600 sq. ft.	Single Family Res-Combo

Accessory Dwelling Units

Index # - File Name: 1.0022 - Single Family Dwellings Data\_Snohomish County.pdf

01 105004 RK	R-9,600	Residential 9,600 sq. ft.	Single Family Res-Combo
01 103912 RK	R-9,600	Residential 9,600 sq. ft.	SFR-Basic
01 108206 RK	R-9,600	Residential 9,600 sq. ft.	Single Family Res-Combo
00 110894 RK	R-5	Rural-5 Acre	Single Family Res-Combo
01 104535 RK	R-5	Rural-5 Acre	Single Family Res-Combo
01 100601 RK	R-5	Rural-5 Acre	Single Family Res-Combo
01 106518 RK	R-5	Rural-5 Acre	Single Family Res-Combo
01 103388 RK	PRD-9,600	Residential 9,600 sq. ft.	Single Family Res-Combo
99 111006 RK	PRD-9,600	Residential 9,600 sq. ft.	SFR-Basic
00 110443 RK	R-9,600	Residential 9,600 sq. ft.	Single Family Res-Combo
01 100370 RK	R-9,600	Residential 9,600 sq. ft.	SFR-Basic
00 110574 RK	R-9,600	Residential 9,600 sq. ft.	SFR-Basic
00 110575 RK	R-9,600	Residential 9,600 sq. ft.	SFR-Basic
01 105198 MH	R-5	Rural-5 Acre	Double Wide
00 107876 RK	R-8,400	Residential 8,400 sq. ft.	Single Family Res-Combo
00 104474 RK	R-8,400	Residential 8,400 sq. ft.	Single Family Res-Combo
01 101712 RK	R-5	Rural-5 Acre	Single Family Res-Combo
01 106910 RK	R-5	Rural-5 Acre	Single Family Res-Combo
01 101892 MH	R-5	Rural-5 Acre	Double Wide
01 101893 MH	R-5	Rural-5 Acre	Double Wide
01 101895 MH	R-5	Rural-5 Acre	Double Wide
00 106114 RK	R-5	Rural-5 Acre	Single Family Res-Combo
01 103223 RK	R-5	Rural-5 Acre	Single Family Res-Combo
01 104727 RK	R-5	Rural-5 Acre	Single Family Res-Combo
99 113062 000 01 MH	R-7,200	Residential 7,200 sq. ft.	Triple Wide
01 107057 RK	R-5	Rural-5 Acre	SFR-Basic
01 107056 RK	R-5	Rural-5 Acre	SFR-Basic
01 103406 RK	LDMR	Low Density Multiple Reside Duplex-Basic	
00 110440 RK	LDMR	Low Density Multiple Reside Duplex-Combo	
00 110438 RK	LDMR	Low Density Multiple Reside Duplex-Combo	
01 103436 RK	LDMR	Low Density Multiple Reside Duplex-Basic	
99 113073 MH	A-10	Agriculture-10 Acre	Double Wide
01 100022 RK	R-5	Rural-5 Acre	Single Family Res-Combo
00 107872 RK	R-9,600	Residential 9,600 sq. ft.	Single Family Res-Combo
00 110890 RK	PRD-9,600	Residential 9,600 sq. ft.	SFR-Basic
01 101029 RK	UC	Urban Center	Duplex-Combo
01 101377 RK	PRD-9,600	Residential 9,600 sq. ft.	SFR-Basic
01 103872 RK	RRT-10	Rural Resource Transition-10	Single Family Res-Combo
01 101379 RK	PRD-9,600	Residential 9,600 sq. ft.	SFR-Basic
01 101028 RK	PRD-9,600	Residential 9,600 sq. ft.	SFR-Basic
01 107604 RK	RRT-10	Rural Resource Transition-10	Single Family Res-Combo
00 108362 RK	F	Forestry	Single Family Res-Combo
01 100429 RK	R-9,600	Residential 9,600 sq. ft.	SFR-Basic
01 105117 RK	R-9,600	Residential 9,600 sq. ft.	Single Family Res-Combo
01 105598 RK	R-9,600	Residential 9,600 sq. ft.	Single Family Res-Combo
01 101286 RK	R-7,200	Residential 7,200 sq. ft.	Single Family Res-Combo
99 114827 MH	F : MC : R-5 : R	Forestry : Mineral Conservat	Double Wide



Accessory Dwelling Units

Index # - File Name: 1.0022 - Single Family Dwellings Data\_Snohomish County.pdf

01 103965 RK	R-5	Rural-5 Acre	Single Family Res-Combo
01 104633 RK	R-5	Rural-5 Acre	Single Family Res-Combo
01 101420 RK	R-5	Rural-5 Acre	Single Family Res-Combo
01 107450 RK	R-5	Rural-5 Acre	Single Family Res-Combo
01 100567 RK	R-5	Rural-5 Acre	Single Family Res-Combo
00 109619 RK	MC	Mineral Conservation	Single Family Res-Combo
01 111362 RK	MR	Multiple Residential	Single Family Res-Combo
01 103240 RK	R-5	Rural-5 Acre	SFR-Basic
01 103241 RK	R-5	Rural-5 Acre	SFR-Basic
01 104115 RK	LDMR	Low Density Multiple Reside	SFR-Basic
01 104125 RK	LDMR	Low Density Multiple Reside	SFR-Basic
01 104124 RK	LDMR	Low Density Multiple Reside	SFR-Basic
99 114728 RK	R-5	Rural-5 Acre	Single Family Res-Combo
01 107697 RK	R-7,200	Residential 7,200 sq. ft.	Single Family Res-Combo
01 100517 RK	R-7,200	Residential 7,200 sq. ft.	Single Family Res-Combo
00 110424 RK	R-7,200	Residential 7,200 sq. ft.	Single Family Res-Combo
01 108100 RK	R-5	Rural-5 Acre	Single Family Res-Combo
00 107049 RK	R-5	Rural-5 Acre	Single Family Res-Combo
01 106734 RK	R-7,200	Residential 7,200 sq. ft.	Single Family Res-Combo
00 109191 RK	R-5	Rural-5 Acre	Single Family Res-Combo
00 106952 RK	R-5	Rural-5 Acre	Single Family Res-Combo
00 107021 RK	R-5	Rural-5 Acre	Single Family Res-Combo
00 110971 RK	R-5	Rural-5 Acre	Single Family Res-Combo
00 110769 RK	R-5	Rural-5 Acre	Single Family Res-Combo
01 101283 RK	R-5	Rural-5 Acre	Single Family Res-Combo
01 104373 RK	R-5	Rural-5 Acre	Single Family Res-Combo
01 107274 RK	R-5	Rural-5 Acre	Single Family Res-Combo
01 111167 RK	R-5	Rural-5 Acre	Single Family Res-Combo
01 104374 RK	R-5	Rural-5 Acre	Single Family Res-Combo
01 100046 RK	R-5	Rural-5 Acre	Single Family Res-Combo
01 107652 RK	R-5	Rural-5 Acre	Single Family Res-Combo
01 103384 RK	R-5	Rural-5 Acre	Single Family Res-Combo
01 105791 RK	R-5	Rural-5 Acre	Single Family Res-Combo
00 106881 RK	F	Forestry	Single Family Res-Combo
01 104118 RK	R-5	Rural-5 Acre	Single Family Res-Combo
01 100510 RK	R-5	Rural-5 Acre	Single Family Res-Combo
01 100511 RK	R-5	Rural-5 Acre	Single Family Res-Combo
01 106647 RK	R-5	Rural-5 Acre	Single Family Res-Combo
01 104214 RK	R-5	Rural-5 Acre	SFR-Basic
00 110632 RK	R-5	Rural-5 Acre	Single Family Res-Combo
00 110864 RK	R-5	Rural-5 Acre	Single Family Res-Combo
00 110860 RK	R-5	Rural-5 Acre	Single Family Res-Combo
00 110702 RK	R-5	Rural-5 Acre	Single Family Res-Combo
00 110705 RK	R-5	Rural-5 Acre	Single Family Res-Combo
01 100807 RK	R-5	Rural-5 Acre	SFR-Basic
01 104277 RK	R-5	Rural-5 Acre	SFR-Basic
01 104305 RK	R-5	Rural-5 Acre	SFR-Basic

Accessory Dwelling Units

Index # - File Name: 1.0022 - Single Family Dwellings Data\_Snohomish County.pdf

01 104233 RK	R-5	Rural-5 Acre	SFR-Basic
01 104236 RK	R-5	Rural-5 Acre	SFR-Basic
01 104276 RK	R-5	Rural-5 Acre	SFR-Basic
01 104784 RK	R-5	Rural-5 Acre	Single Family Res-Combo
01 106651 RK	R-5	Rural-5 Acre	Single Family Res-Combo
01 104218 RK	R-5	Rural-5 Acre	SFR-Basic
01 104213 RK	R-5	Rural-5 Acre	SFR-Basic
00 110253 RK	R-5	Rural-5 Acre	Single Family Res-Combo
00 110530 RK	R-5	Rural-5 Acre	Single Family Res-Combo
00 110633 RK	R-5	Rural-5 Acre	Single Family Res-Combo
00 110635 RK	R-5	Rural-5 Acre	Single Family Res-Combo
00 110528 RK	R-5	Rural-5 Acre	Single Family Res-Combo
00 110526 RK	R-5	Rural-5 Acre	Single Family Res-Combo
00 110531 RK	R-5	Rural-5 Acre	Single Family Res-Combo
00 110525 RK	R-5	Rural-5 Acre	Single Family Res-Combo
01 111963 RK	R-5	Rural-5 Acre	Single Family Res-Combo
01 111858 RK	R-5	Rural-5 Acre	Single Family Res-Combo
01 105645 RK	R-5	Rural-5 Acre	SFR-Basic
01 103722 RK	R-5	Rural-5 Acre	Single Family Res-Combo
01 101013 RK	R-5	Rural-5 Acre	Single Family Res-Combo
00 108085 RK	R-5	Rural-5 Acre	Single Family Res-Combo
00 106271 RK	R-5	Rural-5 Acre	Single Family Res-Combo
00 111078 RK	R-5	Rural-5 Acre	SFR-Basic
01 100126 RK	R-5	Rural-5 Acre	Single Family Res-Combo
00 111077 RK	R-5	Rural-5 Acre	SFR-Basic
01 103323 RK	R-5	Rural-5 Acre	Single Family Res-Combo
01 103334 RK	R-5	Rural-5 Acre	Single Family Res-Combo
01 104245 RK	R-5	Rural-5 Acre	SFR-Basic
01 104246 RK	R-5	Rural-5 Acre	Single Family Res-Combo
01 103321 RK	R-5	Rural-5 Acre	Single Family Res-Combo
01 106018 RK	R-5	Rural-5 Acre	SFR-Basic
01 104216 RK	R-5	Rural-5 Acre	SFR-Basic
01 101558 RK	R-5	Rural-5 Acre	Single Family Res-Combo
01 106643 RK	R-5	Rural-5 Acre	SFR-Basic
00 110707 RK	R-5	Rural-5 Acre	Single Family Res-Combo
00 110634 RK	R-5	Rural-5 Acre	Single Family Res-Combo
00 110631 RK	R-5	Rural-5 Acre	Single Family Res-Combo
00 110701 RK	R-5	Rural-5 Acre	Single Family Res-Combo
00 110863 RK	R-5	Rural-5 Acre	Single Family Res-Combo
01 111200 RK	R-5	Rural-5 Acre	SFR-Basic
01 101561 RK	R-5	Rural-5 Acre	Single Family Res-Combo
00 110861 RK	R-5	Rural-5 Acre	Single Family Res-Combo
00 110859 RK	R-5	Rural-5 Acre	Single Family Res-Combo
01 104304 RK	R-5	Rural-5 Acre	SFR-Basic
00 110703 RK	R-5	Rural-5 Acre	Single Family Res-Combo
01 101067 MH	R-5	Rural-5 Acre	Double Wide
01 106173 RK	CITY	City	SFR-Basic

Accessory Dwelling Units

Index # - File Name: 1.0022 - Single Family Dwellings Data\_Snohomish County.pdf

01 101805 RK	CITY	City	SFR-Basic
01 106180 RK	CITY	City	SFR-Basic
01 107646 RK	CITY	City	SFR-Basic
01 110829 RK	CITY	City	SFR-Basic
01 110831 RK	CITY	City	SFR-Basic
01 110828 RK	CITY	City	SFR-Basic
01 104231 RK	CITY	City	SFR-Basic
01 106179 RK	CITY	City	SFR-Basic
01 101802 RK	CITY	City	SFR-Basic
01 101806 RK	CITY	City	SFR-Basic
01 106174 RK	CITY	City	SFR-Basic
01 110824 RK	CITY	City	SFR-Basic
01 106175 RK	CITY	City	SFR-Basic
01 107643 RK	CITY	City	SFR-Basic
01 106178 RK	CITY	City	SFR-Basic
01 107640 RK	CITY	City	SFR-Basic
01 107637 RK	CITY	City	SFR-Basic
01 107645 RK	CITY	City	SFR-Basic
01 106176 RK	CITY	City	SFR-Basic
01 107641 RK	CITY	City	SFR-Basic
01 110825 RK	CITY	City	SFR-Basic
01 110826 RK	CITY	City	SFR-Basic
01 107642 RK	CITY	City	SFR-Basic
01 105836 RK	CITY	City	Single Family Res-Combo
01 107215 RK	R-5	Rural-5 Acre	Single Family Res-Combo
01 106219 RK	R-7,200	Residential 7,200 sq. ft.	Single Family Res-Combo
01 105596 RK	R-7,200	Residential 7,200 sq. ft.	SFR-Basic
01 101423 RK	R-7,200	Residential 7,200 sq. ft.	SFR-Basic
01 105230 RK	R-7,200	Residential 7,200 sq. ft.	Single Family Res-Combo
01 104163 RK	R-7,200	Residential 7,200 sq. ft.	Single Family Res-Combo
01 101736 RK	R-7,200	Residential 7,200 sq. ft.	Single Family Res-Combo
01 105227 RK	R-7,200	Residential 7,200 sq. ft.	Single Family Res-Combo
01 105758 RK	R-7,200	Residential 7,200 sq. ft.	SFR-Basic
01 105790 RK	R-5	Rural-5 Acre	Single Family Res-Combo
00 110623 RK	R-7,200	Residential 7,200 sq. ft.	SFR-Basic
00 107460 RK	R-7,200	Residential 7,200 sq. ft.	SFR-Basic
00 108704 RK	R-7,200	Residential 7,200 sq. ft.	Single Family Res-Combo
00 108335 RK	R-7,200	Residential 7,200 sq. ft.	SFR-Basic
00 110292 RK	R-7,200	Residential 7,200 sq. ft.	SFR-Basic
01 103514 RK	R-9,600(PRD)	Residential 9,600 sq. ft.	SFR-Basic
01 103929 RK	R-9,600(PRD)	Residential 9,600 sq. ft.	SFR-Basic
01 105599 RK	R-8,400	Residential 8,400 sq. ft.	Single Family Res-Combo
01 103168 RK	R-7,200	Residential 7,200 sq. ft.	SFR-Basic
01 100269 RK	R-7,200	Residential 7,200 sq. ft.	SFR-Basic
01 103499 RK	R-9,600(PRD)	Residential 9,600 sq. ft.	SFR-Basic
01 110935 RK	R-9,600(PRD)	Residential 9,600 sq. ft.	SFR-Basic
01 103510 RK	R-9,600(PRD)	Residential 9,600 sq. ft.	SFR-Basic

Accessory Dwelling Units

Index # - File Name: 1.0022 - Single Family Dwellings Data\_Snohomish County.pdf

01 103505 RK	R-9,600(PRD)	Residential 9,600 sq. ft.	SFR-Basic
01 110929 RK	R-9,600(PRD)	Residential 9,600 sq. ft.	SFR-Basic
01 110926 RK	R-9,600(PRD)	Residential 9,600 sq. ft.	SFR-Basic
01 103502 RK	R-9,600(PRD)	Residential 9,600 sq. ft.	SFR-Basic
01 100475 RK	R-9,600(PRD)	Residential 9,600 sq. ft.	SFR-Basic
01 103177 RK	R-9,600(PRD)	Residential 9,600 sq. ft.	SFR-Basic
01 110936 RK	R-9,600(PRD)	Residential 9,600 sq. ft.	SFR-Basic
01 101721 RK	R-9,600(PRD)	Residential 9,600 sq. ft.	SFR-Basic
01 101727 RK	R-9,600(PRD)	Residential 9,600 sq. ft.	SFR-Basic
00 109130 RK	R-9,600(PRD)	Residential 9,600 sq. ft.	Single Family Res-Combo
01 101732 RK	R-9,600(PRD)	Residential 9,600 sq. ft.	SFR-Basic
01 101724 RK	R-9,600(PRD)	Residential 9,600 sq. ft.	SFR-Basic
01 101725 RK	R-9,600(PRD)	Residential 9,600 sq. ft.	SFR-Basic
01 103509 RK	R-9,600(PRD)	Residential 9,600 sq. ft.	SFR-Basic
01 110830 RK	R-9,600(PRD)	Residential 9,600 sq. ft.	SFR-Basic
01 103515 RK	R-9,600(PRD)	Residential 9,600 sq. ft.	SFR-Basic
01 101730 RK	R-9,600(PRD)	Residential 9,600 sq. ft.	SFR-Basic
01 101517 RK	R-9,600(PRD)	Residential 9,600 sq. ft.	SFR-Basic
01 101519 RK	R-9,600(PRD)	Residential 9,600 sq. ft.	SFR-Basic
01 100476 RK	R-9,600(PRD)	Residential 9,600 sq. ft.	SFR-Basic
01 103516 RK	R-9,600(PRD)	Residential 9,600 sq. ft.	SFR-Basic
01 103500 RK	R-9,600(PRD)	Residential 9,600 sq. ft.	SFR-Basic
01 103523 RK	R-9,600(PRD)	Residential 9,600 sq. ft.	SFR-Basic
01 100499 RK	R-9,600(PRD)	Residential 9,600 sq. ft.	SFR-Basic
01 101518 RK	R-9,600(PRD)	Residential 9,600 sq. ft.	SFR-Basic
01 101720 RK	R-9,600(PRD)	Residential 9,600 sq. ft.	SFR-Basic
01 101726 RK	R-9,600(PRD)	Residential 9,600 sq. ft.	SFR-Basic
01 100498 RK	R-9,600(PRD)	Residential 9,600 sq. ft.	SFR-Basic
01 103174 RK	R-9,600(PRD)	Residential 9,600 sq. ft.	SFR-Basic
01 101719 RK	R-9,600(PRD)	Residential 9,600 sq. ft.	SFR-Basic
01 106013 RK	R-9,600	Residential 9,600 sq. ft.	SFR-Basic
01 106014 RK	R-9,600	Residential 9,600 sq. ft.	SFR-Basic
01 106638 RK	R-9,600	Residential 9,600 sq. ft.	SFR-Basic
01 106810 RK	R-9,600	Residential 9,600 sq. ft.	SFR-Basic
01 106811 RK	R-9,600	Residential 9,600 sq. ft.	SFR-Basic
01 110694 RK	R-9,600	Residential 9,600 sq. ft.	SFR-Basic
01 110696 RK	R-9,600	Residential 9,600 sq. ft.	SFR-Basic
01 107946 RK	R-9,600	Residential 9,600 sq. ft.	SFR-Basic
01 110646 RK	R-9,600	Residential 9,600 sq. ft.	SFR-Basic
01 103501 RK	R-9,600(PRD)	Residential 9,600 sq. ft.	SFR-Basic
00 110681 RK	R-9,600	Residential 9,600 sq. ft.	SFR-Basic
01 100426 RK	R-9,600	Residential 9,600 sq. ft.	SFR-Basic
00 110680 RK	R-9,600	Residential 9,600 sq. ft.	SFR-Basic
00 104779 MH	R-5	Rural-5 Acre	Double Wide
01 100290 RK	R-9,600	Residential 9,600 sq. ft.	SFR-Basic
00 106740 RK	F	Forestry	Single Family Res-Combo
00 110891 RK	PRD-9,600	Residential 9,600 sq. ft.	Single Family Res-Combo

Accessory Dwelling Units

Index # - File Name: 1.0022 - Single Family Dwellings Data\_Snohomish County.pdf

01 100424 RK	PRD-9,600	Residential 9,600 sq. ft.	SFR-Basic
00 110892 RK	PRD-9,600	Residential 9,600 sq. ft.	SFR-Basic
00 110893 RK	PRD-9,600	Residential 9,600 sq. ft.	SFR-Basic
01 103433 RK	R-9,600	Residential 9,600 sq. ft.	SFR-Basic
01 111625 RK	PRD-9,600	Residential 9,600 sq. ft.	SFR-Basic
01 111624 RK	PRD-9,600	Residential 9,600 sq. ft.	SFR-Basic
01 107377 RK	PRD-9,600	Residential 9,600 sq. ft.	SFR-Basic
01 104900 RK	PRD-9,600	Residential 9,600 sq. ft.	SFR-Basic
01 105191 RK	PRD-9,600	Residential 9,600 sq. ft.	SFR-Basic
01 103352 RK	PRD-9,600	Residential 9,600 sq. ft.	SFR-Basic
01 107379 RK	PRD-9,600	Residential 9,600 sq. ft.	Single Family Res-Combo
01 111306 RK	PRD-9,600	Residential 9,600 sq. ft.	SFR-Basic
01 105051 RK	PRD-9,600	Residential 9,600 sq. ft.	SFR-Basic
01 105189 RK	PRD-9,600	Residential 9,600 sq. ft.	SFR-Basic
01 100411 RK	PRD-9,600	Residential 9,600 sq. ft.	SFR-Basic
01 100423 RK	PRD-9,600	Residential 9,600 sq. ft.	SFR-Basic
01 100294 RK	PRD-9,600	Residential 9,600 sq. ft.	SFR-Basic
00 109436 RK	R-5	Rural-5 Acre	Single Family Res-Combo
01 100409 RK	PRD-9,600	Residential 9,600 sq. ft.	SFR-Basic
01 100606 RK	PRD-9,600	Residential 9,600 sq. ft.	SFR-Basic
01 100291 RK	PRD-9,600	Residential 9,600 sq. ft.	SFR-Basic
01 100605 RK	PRD-9,600	Residential 9,600 sq. ft.	SFR-Basic
01 100896 RK	PRD-9,600	Residential 9,600 sq. ft.	SFR-Basic
01 100897 RK	PRD-9,600	Residential 9,600 sq. ft.	SFR-Basic
01 105798 RK	PRD-9,600	Residential 9,600 sq. ft.	SFR-Basic
01 105053 RK	PRD-9,600	Residential 9,600 sq. ft.	Single Family Res-Combo
00 110683 RK	PRD-9,600	Residential 9,600 sq. ft.	SFR-Basic
01 103858 RK	PRD-9,600	Residential 9,600 sq. ft.	SFR-Basic
00 108615 RK	PRD-9,600	Residential 9,600 sq. ft.	Single Family Res-Combo
01 103859 RK	PRD-9,600	Residential 9,600 sq. ft.	SFR-Basic
01 100582 RK	PRD-9,600	Residential 9,600 sq. ft.	Single Family Res-Combo
01 105799 RK	PRD-9,600	Residential 9,600 sq. ft.	SFR-Basic
00 109282 RK	R-5	Rural-5 Acre	SFR-Basic
01 108107 RK	R-9,600	Residential 9,600 sq. ft.	SFR-Basic
01 107759 RK	R-9,600	Residential 9,600 sq. ft.	SFR-Basic
01 107119 RK	R-9,600	Residential 9,600 sq. ft.	SFR-Basic
01 107757 RK	R-9,600	Residential 9,600 sq. ft.	SFR-Basic
01 111373 RK	R-9,600	Residential 9,600 sq. ft.	SFR-Basic
01 111372 RK	R-9,600	Residential 9,600 sq. ft.	SFR-Basic
01 105258 RK	R-9,600	Residential 9,600 sq. ft.	SFR-Basic
01 105259 RK	R-9,600	Residential 9,600 sq. ft.	SFR-Basic
01 105260 RK	R-9,600	Residential 9,600 sq. ft.	SFR-Basic
01 105061 RK	R-9,600	Residential 9,600 sq. ft.	SFR-Basic
01 107760 RK	R-9,600	Residential 9,600 sq. ft.	SFR-Basic
01 105062 RK	R-9,600	Residential 9,600 sq. ft.	SFR-Basic
01 103207 RK	R-9,600	Residential 9,600 sq. ft.	SFR-Basic
01 104265 RK	R-9,600	Residential 9,600 sq. ft.	SFR-Basic

Accessory Dwelling Units

Index # - File Name: 1.0022 - Single Family Dwellings Data\_Snohomish County.pdf

01 105807 RK	R-9,600	Residential 9,600 sq. ft.	SFR-Basic
01 103209 RK	R-9,600	Residential 9,600 sq. ft.	SFR-Basic
01 103201 RK	R-9,600	Residential 9,600 sq. ft.	SFR-Basic
01 103857 RK	R-9,600	Residential 9,600 sq. ft.	SFR-Basic
01 103210 RK	R-9,600	Residential 9,600 sq. ft.	SFR-Basic
01 105808 RK	R-9,600	Residential 9,600 sq. ft.	SFR-Basic
01 103203 RK	R-9,600	Residential 9,600 sq. ft.	SFR-Basic
01 103204 RK	R-9,600	Residential 9,600 sq. ft.	SFR-Basic
01 104264 RK	R-9,600	Residential 9,600 sq. ft.	SFR-Basic
01 103206 RK	R-9,600	Residential 9,600 sq. ft.	SFR-Basic
01 107758 RK	R-9,600	Residential 9,600 sq. ft.	SFR-Basic
01 107326 RK	R-9,600	Residential 9,600 sq. ft.	SFR-Basic
01 105490 RK	R-9,600	Residential 9,600 sq. ft.	SFR-Basic
01 106640 RK	R-9,600	Residential 9,600 sq. ft.	SFR-Basic
01 110693 RK	R-9,600	Residential 9,600 sq. ft.	SFR-Basic
01 105063 RK	R-9,600	Residential 9,600 sq. ft.	SFR-Basic
01 105261 RK	R-9,600	Residential 9,600 sq. ft.	SFR-Basic
01 105491 RK	R-9,600	Residential 9,600 sq. ft.	SFR-Basic
01 104263 RK	R-9,600	Residential 9,600 sq. ft.	SFR-Basic
00 106018 RK	R-9,600	Residential 9,600 sq. ft.	Single Family Res-Combo
01 105809 RK	R-9,600	Residential 9,600 sq. ft.	SFR-Basic
01 104051 RK	R-9,600	Residential 9,600 sq. ft.	SFR-Basic
01 105810 RK	R-9,600	Residential 9,600 sq. ft.	SFR-Basic
00 106016 RK	R-9,600	Residential 9,600 sq. ft.	Single Family Res-Combo
01 104857 RK	R-9,600	Residential 9,600 sq. ft.	SFR-Basic
01 105064 RK	R-9,600	Residential 9,600 sq. ft.	SFR-Basic
01 103211 RK	R-9,600	Residential 9,600 sq. ft.	SFR-Basic
01 104262 RK	R-9,600	Residential 9,600 sq. ft.	SFR-Basic
01 106639 RK	R-9,600	Residential 9,600 sq. ft.	SFR-Basic
01 104477 RK	R-9,600	Residential 9,600 sq. ft.	SFR-Basic
01 110527 RK	R-9,600	Residential 9,600 sq. ft.	SFR-Basic
01 110804 RK	R-9,600	Residential 9,600 sq. ft.	SFR-Basic
01 100356 RK	PRD-9,600	Residential 9,600 sq. ft.	SFR-Basic
01 100354 RK	PRD-9,600	Residential 9,600 sq. ft.	SFR-Basic
01 101058 RK	R-5	Rural-5 Acre	Single Family Res-Combo
01 100058 MH	R-5	Rural-5 Acre	Double Wide
01 103472 RK	R-8,400	Residential 8,400 sq. ft.	SFR-Basic
01 103473 RK	R-8,400	Residential 8,400 sq. ft.	SFR-Basic
00 110576 RK	R-8,400	Residential 8,400 sq. ft.	SFR-Basic
00 110577 RK	R-8,400	Residential 8,400 sq. ft.	SFR-Basic
01 104913 RK	R-8,400	Residential 8,400 sq. ft.	SFR-Basic
01 105548 RK	R-8,400	Residential 8,400 sq. ft.	Single Family Res-Combo
99 115915 RK	R-8,400	Residential 8,400 sq. ft.	Single Family Res-Combo
01 104914 RK	R-8,400	Residential 8,400 sq. ft.	SFR-Basic
01 101115 RK	PRD-8,400	Residential 8,400 sq. ft.	SFR-Basic
01 101580 RK	R-8,400	Residential 8,400 sq. ft.	SFR-Basic
01 101809 RK	R-8,400	Residential 8,400 sq. ft.	SFR-Basic

Accessory Dwelling Units

Index # - File Name: 1.0022 - Single Family Dwellings Data\_Snohomish County.pdf

01 103823 RK	F	Forestry	Single Family Res-Combo
00 101092 RK	R-7,200	Residential 7,200 sq. ft.	Single Family Res-Combo
01 107522 RK	R-8,400	Residential 8,400 sq. ft.	SFR-Basic
01 107177 RK	R-8,400	Residential 8,400 sq. ft.	SFR-Basic
01 107523 RK	R-8,400	Residential 8,400 sq. ft.	SFR-Basic
01 106851 RK	R-8,400	Residential 8,400 sq. ft.	SFR-Basic
01 103255 RK	R-8,400	Residential 8,400 sq. ft.	SFR-Basic
01 106850 RK	R-8,400	Residential 8,400 sq. ft.	SFR-Basic
01 104296 RK	R-8,400	Residential 8,400 sq. ft.	SFR-Basic
01 101807 RK	R-8,400	Residential 8,400 sq. ft.	SFR-Basic
01 104298 RK	R-8,400	Residential 8,400 sq. ft.	SFR-Basic
01 106033 RK	R-8,400	Residential 8,400 sq. ft.	SFR-Basic
01 106034 RK	R-8,400	Residential 8,400 sq. ft.	SFR-Basic
01 100128 RK	R-8,400	Residential 8,400 sq. ft.	SFR-Basic
01 106035 RK	R-8,400	Residential 8,400 sq. ft.	SFR-Basic
00 111049 RK	R-8,400	Residential 8,400 sq. ft.	SFR-Basic
00 104574 RK	R-8,400	Residential 8,400 sq. ft.	Single Family Res-Combo
01 100674 RK	R-8,400	Residential 8,400 sq. ft.	SFR-Basic
01 104300 RK	R-8,400	Residential 8,400 sq. ft.	SFR-Basic
01 104497 RK	R-8,400	Residential 8,400 sq. ft.	SFR-Basic
01 105837 RK	R-8,400	Residential 8,400 sq. ft.	SFR-Basic
01 101237 RK	R-8,400	Residential 8,400 sq. ft.	SFR-Basic
01 100474 RK	R-8,400	Residential 8,400 sq. ft.	SFR-Basic
00 105137 RK	R-8,400	Residential 8,400 sq. ft.	Single Family Res-Combo
01 100392 RK	CITY	City	SFR-Basic
00 101686 RK	CITY	City	Single Family Res-Combo
01 100391 RK	CITY	City	SFR-Basic
01 100390 RK	CITY	City	SFR-Basic
01 103396 RK	R-7,200	Residential 7,200 sq. ft.	Single Family Res-Combo
01 100516 RK	R-7,200	Residential 7,200 sq. ft.	Single Family Res-Combo
00 104480 RK	R-5	Rural-5 Acre	Single Family Res-Combo
00 109281 RK	R-5	Rural-5 Acre	SFR-Basic
00 104393 RK	R-5	Rural-5 Acre	Single Family Res-Combo
01 101018 RK	R-5	Rural-5 Acre	Single Family Res-Combo
00 104148 MH	R-5	Rural-5 Acre	Double Wide
01 105747 MH	R-5	Rural-5 Acre	Single Wide
01 106479 RK	R-5	Rural-5 Acre	Single Family Res-Combo
00 104146 MH	R-5	Rural-5 Acre	Double Wide
01 101462 RK	R-9,600	Residential 9,600 sq. ft.	Single Family Res-Combo
00 107941 RK	R-9,600	Residential 9,600 sq. ft.	Single Family Res-Combo
01 105007 RK	R-9,600	Residential 9,600 sq. ft.	Single Family Res-Combo
00 105716 RK	R-9,600	Residential 9,600 sq. ft.	Single Family Res-Combo
01 100988 MH	R-5	Rural-5 Acre	Triple Wide
01 106703 RK	R-5	Rural-5 Acre	Single Family Res-Combo
00 103971 RK	R-5	Rural-5 Acre	Single Family Res-Combo
01 107238 RK	R-5	Rural-5 Acre	Single Family Res-Combo
00 108869 RK	R-9,600	Residential 9,600 sq. ft.	Single Family Res-Combo

Accessory Dwelling Units

Index # - File Name: 1.0022 - Single Family Dwellings Data\_Snohomish County.pdf

01 100307 RK	R-9,600	Residential 9,600 sq. ft.	Single Family Res-Combo
00 106072 RK	R-9,600	Residential 9,600 sq. ft.	Single Family Res-Combo
01 105944 RK	R-9,600	Residential 9,600 sq. ft.	Single Family Res-Combo
01 107503 RK	PRD SA-1	Suburban Agriculture-1 Acre Duplex-Combo	
01 107804 RK	PRD-LDMR	Low Density Multiple Reside	Single Family Res-Combo
01 100358 RK	CITY	City	Single Family Res-Combo
00 109338 RK	R-5	Rural-5 Acre	Single Family Res-Combo
01 100852 RK	R-7,200	Residential 7,200 sq. ft.	SFR-Basic
00 110766 RK	R-7,200	Residential 7,200 sq. ft.	SFR-Basic
00 110767 RK	R-7,200	Residential 7,200 sq. ft.	SFR-Basic
00 110768 RK	R-7,200	Residential 7,200 sq. ft.	SFR-Basic
00 110771 RK	R-7,200	Residential 7,200 sq. ft.	SFR-Basic
00 110773 RK	R-7,200	Residential 7,200 sq. ft.	SFR-Basic
01 100850 RK	R-7,200	Residential 7,200 sq. ft.	SFR-Basic
01 100853 RK	R-7,200	Residential 7,200 sq. ft.	SFR-Basic
00 108657 RK	R-7,200	Residential 7,200 sq. ft.	SFR-Basic
01 100756 RK	R-7,200	Residential 7,200 sq. ft.	SFR-Basic
01 100754 RK	R-7,200	Residential 7,200 sq. ft.	SFR-Basic
01 100761 RK	R-7,200	Residential 7,200 sq. ft.	SFR-Basic
01 100758 RK	R-7,200	Residential 7,200 sq. ft.	SFR-Basic
01 100757 RK	R-7,200	Residential 7,200 sq. ft.	SFR-Basic
01 100755 RK	R-7,200	Residential 7,200 sq. ft.	SFR-Basic
01 100759 RK	R-7,200	Residential 7,200 sq. ft.	SFR-Basic
01 100760 RK	R-7,200	Residential 7,200 sq. ft.	SFR-Basic
00 110618 MH	R-5	Rural-5 Acre	Single Wide
00 108463 RK	RD	Rural Diversification	Single Family Res-Combo
01 100895 RK	R-9,600	Residential 9,600 sq. ft.	SFR-Basic
01 106308 RK	R-5	Rural-5 Acre	Single Family Res-Combo
00 110015 RK	R-5	Rural-5 Acre	Single Family Res-Combo
00 110152 RK	R-5	Rural-5 Acre	Single Family Res-Combo
00 110144 RK	R-5	Rural-5 Acre	Single Family Res-Combo
01 104624 RK	R-9,600	Residential 9,600 sq. ft.	Single Family Res-Combo
01 107802 MH	R-5	Rural-5 Acre	Double Wide
01 107927 RK	R-5	Rural-5 Acre	Single Family Res-Combo
01 104984 RK	R-5	Rural-5 Acre	SFR-Basic
01 113377 RK	CITY	City	SFR-Basic
01 113378 RK	CITY	City	SFR-Basic
01 113653 RK	CITY	City	SFR-Basic
02 100350 RK	CITY	City	SFR-Basic
02 100349 RK	CITY	City	SFR-Basic
02 100348 RK	CITY	City	SFR-Basic
02 100347 RK	CITY	City	SFR-Basic
02 100346 RK	CITY	City	SFR-Basic
02 101824 RK	CITY	City	SFR-Basic
02 101825 RK	CITY	City	SFR-Basic
02 101826 RK	CITY	City	SFR-Basic
02 101827 RK	TRIBES	Native American Land	SFR-Basic



Accessory Dwelling Units

Index # - File Name: 1.0022 - Single Family Dwellings Data\_Snohomish County.pdf

02 101828 RK	CITY	City	SFR-Basic
02 103540 RK	CITY	City	SFR-Basic
02 104172 RK	CITY	City	SFR-Basic
02 104173 RK	CITY	City	SFR-Basic
02 104507 RK	CITY	City	SFR-Basic
02 104506 RK	CITY	City	SFR-Basic
02 104508 RK	CITY	City	SFR-Basic
02 103414 RK	CITY	City	SFR-Basic
02 103415 RK	CITY	City	SFR-Basic
02 104510 RK	CITY	City	SFR-Basic
02 103416 RK	CITY	City	SFR-Basic
02 104511 RK	CITY	City	SFR-Basic
02 103543 RK	R-5	Rural-5 Acre	Single Family Res-Combo
02 103582 RK	R-5	Rural-5 Acre	Single Family Res-Combo
02 103586 RK	R-5	Rural-5 Acre	Single Family Res-Combo
02 103590 RK	R-5	Rural-5 Acre	Single Family Res-Combo
01 113102 RK	R-5	Rural-5 Acre	SFR-Basic
01 113103 RK	R-5	Rural-5 Acre	SFR-Basic
02 100613 RK	R-5	Rural-5 Acre	SFR-Basic
02 103720 RK	R-5	Rural-5 Acre	Single Family Res-Combo
02 103477 RK	R-5	Rural-5 Acre	Single Family Res-Combo
02 102761 RK	R-5	Rural-5 Acre	Single Family Res-Combo
02 102768 RK	R-5	Rural-5 Acre	Single Family Res-Combo
02 103162 RK	R-5	Rural-5 Acre	Single Family Res-Combo
02 103165 RK	R-5	Rural-5 Acre	Single Family Res-Combo
02 102743 RK	R-5	Rural-5 Acre	Single Family Res-Combo
02 102763 RK	R-5	Rural-5 Acre	Single Family Res-Combo
02 102764 RK	R-5	Rural-5 Acre	Single Family Res-Combo
02 102767 RK	R-5	Rural-5 Acre	Single Family Res-Combo
02 100208 RK	R-5	Rural-5 Acre	Single Family Res-Combo
02 100209 RK	R-5	Rural-5 Acre	Single Family Res-Combo
02 100206 RK	R-5	Rural-5 Acre	Single Family Res-Combo
02 102766 RK	R-5	Rural-5 Acre	Single Family Res-Combo
02 108400 RK	R-5	Rural-5 Acre	Single Family Res-Combo
02 107706 RK	R-5	Rural-5 Acre	Single Family Res-Combo
02 101421 RK	R-5	Rural-5 Acre	Single Family Res-Combo
02 100950 RK	CITY	City	SFR-Basic
02 100955 RK	CITY	City	SFR-Basic
02 102545 RK	CITY	City	SFR-Basic
02 101740 RK	CITY	City	SFR-Basic
02 102546 RK	CITY	City	SFR-Basic
02 101741 RK	CITY	City	SFR-Basic
02 102550 RK	CITY	City	SFR-Basic
02 102551 RK	CITY	City	SFR-Basic
02 102547 RK	CITY	City	SFR-Basic
02 101742 RK	CITY	City	SFR-Basic
02 102549 RK	CITY	City	SFR-Basic

Accessory Dwelling Units

Index # - File Name: 1.0022 - Single Family Dwellings Data\_Snohomish County.pdf

02 102887 RK	CITY	City	Single Family Res-Combo
02 102552 RK	CITY	City	SFR-Basic
02 101745 RK	CITY	City	SFR-Basic
02 102553 RK	CITY	City	SFR-Basic
02 102554 RK	CITY	City	SFR-Basic
02 101746 RK	CITY	City	SFR-Basic
02 101743 RK	CITY	City	SFR-Basic
02 101744 RK	CITY	City	SFR-Basic
02 101747 RK	CITY	City	SFR-Basic
02 102555 RK	CITY	City	SFR-Basic
02 102556 RK	CITY	City	SFR-Basic
02 101748 RK	CITY	City	SFR-Basic
02 102557 RK	CITY	City	SFR-Basic
02 102558 RK	CITY	City	SFR-Basic
02 101749 RK	CITY	City	SFR-Basic
02 102559 RK	CITY	City	SFR-Basic
02 102560 RK	CITY	City	SFR-Basic
02 101750 RK	CITY	City	SFR-Basic
02 102562 RK	CITY	City	SFR-Basic
02 102563 RK	CITY	City	SFR-Basic
02 101751 RK	CITY	City	SFR-Basic
02 102564 RK	CITY	City	SFR-Basic
02 102565 RK	CITY	City	SFR-Basic
02 101752 RK	CITY	City	SFR-Basic
02 102566 RK	CITY	City	SFR-Basic
02 101753 RK	CITY	City	SFR-Basic
02 102320 RK	CITY	City	SFR-Basic
02 100957 RK	CITY	City	SFR-Basic
02 100970 RK	CITY	City	Single Family Res-Combo
02 102323 RK	CITY	City	SFR-Basic
02 102567 RK	CITY	City	SFR-Basic
01 112505 RK	A-10	Agriculture-10 Acre	Single Family Res-Combo
02 100351 RK	CITY	City	SFR-Basic
01 113537 RK	CITY	City	SFR-Basic
01 113538 RK	CITY	City	SFR-Basic
01 113539 RK	CITY	City	SFR-Basic
01 113540 RK	CITY	City	SFR-Basic
01 113542 RK	CITY	City	SFR-Basic
02 103069 RK	R-5	Rural-5 Acre	SFR-Basic
02 103383 RK	R-5	Rural-5 Acre	SFR-Basic
02 104553 RK	R-5	Rural-5 Acre	SFR-Basic
02 107469 RK	R-5	Rural-5 Acre	Single Family Res-Combo
02 101151 RK	R-5	Rural-5 Acre	Single Family Res-Combo
02 103892 RK	PRD-7,200	Residential 7,200 sq. ft.	Single Family Res-Combo
02 100088 RK	PRD-7,200	Residential 7,200 sq. ft.	Single Family Res-Combo
02 100243 RK	PRD-7,200	Residential 7,200 sq. ft.	Single Family Res-Combo
02 100244 RK	PRD-7,200	Residential 7,200 sq. ft.	Single Family Res-Combo

Accessory Dwelling Units

Index # - File Name: 1.0022 - Single Family Dwellings Data\_Snohomish County.pdf

02 101684 RK	PRD-7,200	Residential 7,200 sq. ft.	SFR-Basic
02 100247 RK	PRD-7,200	Residential 7,200 sq. ft.	SFR-Basic
02 100246 RK	PRD-7,200	Residential 7,200 sq. ft.	SFR-Basic
01 113608 RK	PRD-7,200	Residential 7,200 sq. ft.	SFR-Basic
02 101160 RK	PRD-7,200	Residential 7,200 sq. ft.	Single Family Res-Combo
01 113610 RK	PRD-7,200	Residential 7,200 sq. ft.	SFR-Basic
02 100090 RK	PRD-7,200	Residential 7,200 sq. ft.	Single Family Res-Combo
02 101158 RK	PRD-7,200	Residential 7,200 sq. ft.	Single Family Res-Combo
01 113611 RK	PRD-7,200	Residential 7,200 sq. ft.	SFR-Basic
02 100288 RK	PRD-7,200	Residential 7,200 sq. ft.	Single Family Res-Combo
02 100968 MH	CITY	City	Triple Wide
02 103068 RK	R-5	Rural-5 Acre	SFR-Basic
02 104554 RK	R-5	Rural-5 Acre	Single Family Res-Combo
02 109226 RK	R-5	Rural-5 Acre	Single Family Res-Combo
02 107219 RK	R-5	Rural-5 Acre	Single Family Res-Combo
01 113479 RK	R-5	Rural-5 Acre	Duplex-Combo
02 101608 MH	R-5	Rural-5 Acre	Double Wide
02 100753 MH	R-5	Rural-5 Acre	Double Wide
02 100058 RK	R-7,200	Residential 7,200 sq. ft.	SFR-Basic
02 100231 RK	R-5	Rural-5 Acre	Single Family Res-Combo
02 100395 RK	R-5	Rural-5 Acre	Single Family Res-Combo
02 100394 RK	R-5	Rural-5 Acre	Single Family Res-Combo
02 101237 RK	PRD-9,600	Residential 9,600 sq. ft.	SFR-Basic
02 104490 RK	PRD-9,600	Residential 9,600 sq. ft.	SFR-Basic
02 101234 RK	PRD-9,600	Residential 9,600 sq. ft.	SFR-Basic
02 101864 RK	PRD-9,600	Residential 9,600 sq. ft.	SFR-Basic
02 101866 RK	PRD-9,600	Residential 9,600 sq. ft.	SFR-Basic
02 104486 RK	PRD-9,600	Residential 9,600 sq. ft.	SFR-Basic
02 104488 RK	PRD-9,600	Residential 9,600 sq. ft.	SFR-Basic
02 103270 RK	PRD-9,600	Residential 9,600 sq. ft.	SFR-Basic
02 104489 RK	PRD-9,600	Residential 9,600 sq. ft.	SFR-Basic
02 104494 RK	PRD-9,600	Residential 9,600 sq. ft.	SFR-Basic
02 104495 RK	PRD-9,600	Residential 9,600 sq. ft.	SFR-Basic
02 104491 RK	PRD-9,600	Residential 9,600 sq. ft.	SFR-Basic
02 104502 RK	PRD-9,600	Residential 9,600 sq. ft.	SFR-Basic
02 102051 RK	PRD-9,600	Residential 9,600 sq. ft.	SFR-Basic
02 104493 RK	PRD-9,600	Residential 9,600 sq. ft.	SFR-Basic
02 104492 RK	PRD-9,600	Residential 9,600 sq. ft.	SFR-Basic
02 104497 RK	PRD-9,600	Residential 9,600 sq. ft.	SFR-Basic
02 104487 RK	PRD-9,600	Residential 9,600 sq. ft.	SFR-Basic
02 103262 RK	PRD-9,600	Residential 9,600 sq. ft.	SFR-Basic
02 101238 RK	PRD-9,600	Residential 9,600 sq. ft.	SFR-Basic
02 101233 RK	PRD-9,600	Residential 9,600 sq. ft.	SFR-Basic
02 101239 RK	PRD-9,600	Residential 9,600 sq. ft.	SFR-Basic
02 101236 RK	PRD-9,600	Residential 9,600 sq. ft.	SFR-Basic
02 102052 RK	PRD-9,600	Residential 9,600 sq. ft.	SFR-Basic
02 102053 RK	PRD-9,600	Residential 9,600 sq. ft.	SFR-Basic

## Accessory Dwelling Units

Index # - File Name: 1.0022 - Single Family Dwellings Data\_Snohomish County.pdf

02 103269 RK	PRD-9,600	Residential 9,600 sq. ft.	SFR-Basic
02 101867 RK	PRD-9,600	Residential 9,600 sq. ft.	SFR-Basic
02 101865 RK	PRD-9,600	Residential 9,600 sq. ft.	SFR-Basic
02 101868 RK	PRD-9,600	Residential 9,600 sq. ft.	SFR-Basic
02 101863 RK	PRD-9,600	Residential 9,600 sq. ft.	SFR-Basic
02 103265 RK	PRD-9,600	Residential 9,600 sq. ft.	SFR-Basic
02 103825 RK	PRD-9,600	Residential 9,600 sq. ft.	SFR-Basic
02 104501 RK	PRD-9,600	Residential 9,600 sq. ft.	SFR-Basic
02 104499 RK	PRD-9,600	Residential 9,600 sq. ft.	SFR-Basic
02 103263 RK	PRD-9,600	Residential 9,600 sq. ft.	SFR-Basic
02 103823 RK	PRD-9,600	Residential 9,600 sq. ft.	SFR-Basic
02 104496 RK	PRD-9,600	Residential 9,600 sq. ft.	SFR-Basic
02 104498 RK	PRD-9,600	Residential 9,600 sq. ft.	SFR-Basic
02 102570 RK	PRD-9,600	Residential 9,600 sq. ft.	SFR-Basic
02 102569 RK	PRD-9,600	Residential 9,600 sq. ft.	SFR-Basic
02 102054 RK	PRD-9,600	Residential 9,600 sq. ft.	SFR-Basic
02 102055 RK	PRD-9,600	Residential 9,600 sq. ft.	SFR-Basic
02 102056 RK	PRD-9,600	Residential 9,600 sq. ft.	SFR-Basic
02 102057 RK	PRD-9,600	Residential 9,600 sq. ft.	SFR-Basic
02 100380 MH	R-5	Rural-5 Acre	Double Wide
02 101829 MH	R-5	Rural-5 Acre	Triple Wide
02 105740 RK	PRD-9,600	Residential 9,600 sq. ft.	SFR-Basic
02 105731 RK	PRD-9,600	Residential 9,600 sq. ft.	SFR-Basic
02 105750 RK	PRD-9,600	Residential 9,600 sq. ft.	SFR-Basic
02 105761 RK	PRD-9,600	Residential 9,600 sq. ft.	SFR-Basic
02 105026 RK	PRD-9,600	Residential 9,600 sq. ft.	SFR-Basic
02 105012 RK	PRD-9,600	Residential 9,600 sq. ft.	SFR-Basic
02 104981 RK	PRD-9,600	Residential 9,600 sq. ft.	SFR-Basic
02 105001 RK	PRD-9,600	Residential 9,600 sq. ft.	SFR-Basic
02 104990 RK	PRD-9,600	Residential 9,600 sq. ft.	SFR-Basic
02 105021 RK	PRD-9,600	Residential 9,600 sq. ft.	SFR-Basic
02 104274 RK	PRD-8,400	Residential 8,400 sq. ft.	SFR-Basic
02 104459 RK	PRD-8,400	Residential 8,400 sq. ft.	SFR-Basic
02 104460 RK	PRD-8,400	Residential 8,400 sq. ft.	SFR-Basic
02 104461 RK	PRD-8,400	Residential 8,400 sq. ft.	SFR-Basic
02 104462 RK	PRD-8,400	Residential 8,400 sq. ft.	SFR-Basic
02 105778 RK	PRD-8,400	Residential 8,400 sq. ft.	SFR-Basic
02 105782 RK	PRD-8,400	Residential 8,400 sq. ft.	SFR-Basic
02 105779 RK	PRD-8,400	Residential 8,400 sq. ft.	SFR-Basic
02 105783 RK	PRD-8,400	Residential 8,400 sq. ft.	SFR-Basic
02 104713 RK	PRD-8,400	Residential 8,400 sq. ft.	SFR-Basic
02 103508 RK	PRD-8,400	Residential 8,400 sq. ft.	SFR-Basic
02 103507 RK	PRD-8,400	Residential 8,400 sq. ft.	SFR-Basic
02 105784 RK	PRD-8,400	Residential 8,400 sq. ft.	SFR-Basic
02 105796 RK	PRD-8,400	Residential 8,400 sq. ft.	SFR-Basic
02 105797 RK	PRD-8,400	Residential 8,400 sq. ft.	SFR-Basic
02 107654 RK	PRD-8,400	Residential 8,400 sq. ft.	SFR-Basic

Accessory Dwelling Units

Index # - File Name: 1.0022 - Single Family Dwellings Data\_Snohomish County.pdf

02 105136 RK	PRD-8,400	Residential 8,400 sq. ft.	SFR-Basic
02 105138 RK	PRD-8,400	Residential 8,400 sq. ft.	SFR-Basic
02 105416 RK	PRD-8,400	Residential 8,400 sq. ft.	SFR-Basic
02 105140 RK	PRD-8,400	Residential 8,400 sq. ft.	SFR-Basic
02 105142 RK	PRD-8,400	Residential 8,400 sq. ft.	SFR-Basic
02 104465 RK	PRD-8,400	Residential 8,400 sq. ft.	SFR-Basic
02 104466 RK	PRD-8,400	Residential 8,400 sq. ft.	SFR-Basic
02 101003 RK	PRD-8,400	Residential 8,400 sq. ft.	SFR-Basic
02 104052 RK	PRD-8,400	Residential 8,400 sq. ft.	Duplex-Combo
02 104051 RK	PRD-8,400	Residential 8,400 sq. ft.	Duplex-Combo
02 101004 RK	PRD-8,400	Residential 8,400 sq. ft.	SFR-Basic
02 105794 RK	PRD-8,400	Residential 8,400 sq. ft.	SFR-Basic
02 105785 RK	PRD-8,400	Residential 8,400 sq. ft.	SFR-Basic
02 105780 RK	PRD-8,400	Residential 8,400 sq. ft.	SFR-Basic
02 105795 RK	PRD-8,400	Residential 8,400 sq. ft.	SFR-Basic
02 105786 RK	PRD-8,400	Residential 8,400 sq. ft.	SFR-Basic
02 108186 RK	PRD-8,400	Residential 8,400 sq. ft.	SFR-Basic
02 105791 RK	PRD-8,400	Residential 8,400 sq. ft.	SFR-Basic
02 105788 RK	PRD-8,400	Residential 8,400 sq. ft.	SFR-Basic
02 105789 RK	PRD-8,400	Residential 8,400 sq. ft.	SFR-Basic
02 105792 RK	PRD-8,400	Residential 8,400 sq. ft.	SFR-Basic
02 105790 RK	PRD-8,400	Residential 8,400 sq. ft.	SFR-Basic
02 105143 RK	PRD-8,400	Residential 8,400 sq. ft.	SFR-Basic
02 107123 RK	PRD-8,400	Residential 8,400 sq. ft.	SFR-Basic
02 108316 RK	PRD-8,400	Residential 8,400 sq. ft.	SFR-Basic
02 103505 RK	PRD-8,400	Residential 8,400 sq. ft.	SFR-Basic
02 103504 RK	PRD-8,400	Residential 8,400 sq. ft.	SFR-Basic
02 103103 RK	PRD-8,400	Residential 8,400 sq. ft.	SFR-Basic
02 103291 RK	PRD-8,400	Residential 8,400 sq. ft.	SFR-Basic
02 105135 RK	PRD-8,400	Residential 8,400 sq. ft.	SFR-Basic
02 105417 RK	PRD-8,400	Residential 8,400 sq. ft.	SFR-Basic
02 104273 RK	PRD-8,400	Residential 8,400 sq. ft.	SFR-Basic
02 105793 RK	PRD-8,400	Residential 8,400 sq. ft.	SFR-Basic
02 109214 RK	PRD-8,400	Residential 8,400 sq. ft.	SFR-Basic
02 109215 RK	PRD-8,400	Residential 8,400 sq. ft.	SFR-Basic
02 109216 RK	PRD-8,400	Residential 8,400 sq. ft.	SFR-Basic
02 109390 RK	PRD-8,400	Residential 8,400 sq. ft.	SFR-Basic
02 109393 RK	PRD-8,400	Residential 8,400 sq. ft.	SFR-Basic
02 108672 RK	PRD-8,400	Residential 8,400 sq. ft.	SFR-Basic
02 110324 RK	PRD-8,400	Residential 8,400 sq. ft.	SFR-Basic
02 108671 RK	PRD-8,400	Residential 8,400 sq. ft.	SFR-Basic
02 109394 RK	PRD-8,400	Residential 8,400 sq. ft.	SFR-Basic
02 109395 RK	PRD-8,400	Residential 8,400 sq. ft.	SFR-Basic
02 109217 RK	PRD-8,400	Residential 8,400 sq. ft.	SFR-Basic
02 109047 RK	PRD-8,400	Residential 8,400 sq. ft.	SFR-Basic
02 108521 RK	PRD-8,400	Residential 8,400 sq. ft.	SFR-Basic
02 105748 RK	PRD-9,600	Residential 9,600 sq. ft.	SFR-Basic

Accessory Dwelling Units

Index # - File Name: 1.0022 - Single Family Dwellings Data\_Snohomish County.pdf

02 105757 RK	PRD-9,600	Residential 9,600 sq. ft.	SFR-Basic
02 105737 RK	PRD-9,600	Residential 9,600 sq. ft.	SFR-Basic
02 102855 RK	PRD-9,600	Residential 9,600 sq. ft.	SFR-Basic
02 102856 RK	PRD-9,600	Residential 9,600 sq. ft.	SFR-Basic
02 102857 RK	PRD-9,600	Residential 9,600 sq. ft.	SFR-Basic
02 102858 RK	PRD-9,600	Residential 9,600 sq. ft.	SFR-Basic
02 102859 RK	PRD-9,600	Residential 9,600 sq. ft.	SFR-Basic
02 103607 RK	PRD-9,600	Residential 9,600 sq. ft.	SFR-Basic
02 103606 RK	PRD-9,600	Residential 9,600 sq. ft.	SFR-Basic
02 103605 RK	PRD-9,600	Residential 9,600 sq. ft.	SFR-Basic
02 104890 RK	PRD-9,600	Residential 9,600 sq. ft.	SFR-Basic
02 104891 RK	PRD-9,600	Residential 9,600 sq. ft.	SFR-Basic
02 104887 RK	PRD-9,600	Residential 9,600 sq. ft.	SFR-Basic
02 104894 RK	PRD-9,600	Residential 9,600 sq. ft.	SFR-Basic
02 105006 RK	PRD-9,600	Residential 9,600 sq. ft.	SFR-Basic
02 105027 RK	PRD-9,600	Residential 9,600 sq. ft.	SFR-Basic
02 104893 RK	PRD-9,600	Residential 9,600 sq. ft.	SFR-Basic
02 104886 RK	PRD-9,600	Residential 9,600 sq. ft.	SFR-Basic
02 104889 RK	PRD-9,600	Residential 9,600 sq. ft.	SFR-Basic
02 104888 RK	PRD-9,600	Residential 9,600 sq. ft.	SFR-Basic
02 103604 RK	PRD-9,600	Residential 9,600 sq. ft.	SFR-Basic
02 103603 RK	PRD-9,600	Residential 9,600 sq. ft.	SFR-Basic
02 103602 RK	PRD-9,600	Residential 9,600 sq. ft.	SFR-Basic
02 103601 RK	PRD-9,600	Residential 9,600 sq. ft.	SFR-Basic
02 102860 RK	PRD-9,600	Residential 9,600 sq. ft.	SFR-Basic
02 102861 RK	PRD-9,600	Residential 9,600 sq. ft.	SFR-Basic
02 102862 RK	PRD-9,600	Residential 9,600 sq. ft.	SFR-Basic
02 105730 RK	PRD-9,600	Residential 9,600 sq. ft.	SFR-Basic
02 105775 RK	PRD-9,600	Residential 9,600 sq. ft.	SFR-Basic
02 105739 RK	PRD-9,600	Residential 9,600 sq. ft.	SFR-Basic
02 105760 RK	PRD-9,600	Residential 9,600 sq. ft.	SFR-Basic
02 105774 RK	PRD-9,600	Residential 9,600 sq. ft.	SFR-Basic
02 105749 RK	PRD-9,600	Residential 9,600 sq. ft.	SFR-Basic
02 103408 RK	R-9,600	Residential 9,600 sq. ft.	Single Family Res-Combo
02 103615 RK	R-9,600	Residential 9,600 sq. ft.	Duplex-Combo
02 109048 RK	PRD-8,400	Residential 8,400 sq. ft.	SFR-Basic
02 102787 RK	PRD-8,400	Residential 8,400 sq. ft.	SFR-Basic
02 102786 RK	PRD-8,400	Residential 8,400 sq. ft.	SFR-Basic
02 103105 RK	PRD-8,400	Residential 8,400 sq. ft.	SFR-Basic
02 109666 RK	PRD-8,400	Residential 8,400 sq. ft.	SFR-Basic
02 106740 RK	PRD-8,400	Residential 8,400 sq. ft.	Single Family Res-Combo
02 101852 RK	PRD-8,400	Residential 8,400 sq. ft.	SFR-Basic
02 101853 RK	PRD-8,400	Residential 8,400 sq. ft.	SFR-Basic
02 102527 RK	PRD-8,400	Residential 8,400 sq. ft.	SFR-Basic
02 102528 RK	PRD-8,400	Residential 8,400 sq. ft.	SFR-Basic
02 102534 RK	PRD-8,400	Residential 8,400 sq. ft.	SFR-Basic
02 102533 RK	PRD-8,400	Residential 8,400 sq. ft.	SFR-Basic

Accessory Dwelling Units

Index # - File Name: 1.0022 - Single Family Dwellings Data\_Snohomish County.pdf

02 101617 RK	PRD-8,400	Residential 8,400 sq. ft.	SFR-Basic
02 101618 RK	PRD-8,400	Residential 8,400 sq. ft.	SFR-Basic
02 101109 RK	PRD-8,400	Residential 8,400 sq. ft.	SFR-Basic
02 101108 RK	PRD-8,400	Residential 8,400 sq. ft.	SFR-Basic
02 109665 RK	PRD-8,400	Residential 8,400 sq. ft.	SFR-Basic
02 109855 RK	PRD-8,400	Residential 8,400 sq. ft.	SFR-Basic
02 102144 RK	PRD-8,400	Residential 8,400 sq. ft.	SFR-Basic
02 102145 RK	PRD-8,400	Residential 8,400 sq. ft.	SFR-Basic
02 102146 RK	PRD-8,400	Residential 8,400 sq. ft.	SFR-Basic
02 105415 RK	PRD-8,400	Residential 8,400 sq. ft.	SFR-Basic
02 108317 RK	PRD-8,400	Residential 8,400 sq. ft.	SFR-Basic
02 102149 RK	PRD-8,400	Residential 8,400 sq. ft.	SFR-Basic
02 102508 RK	R-9,600	Residential 9,600 sq. ft.	SFR-Basic
02 102184 RK	R-9,600	Residential 9,600 sq. ft.	SFR-Basic
02 103611 RK	CITY	City	SFR-Basic
02 103613 RK	CITY	City	SFR-Basic
02 104813 RK	CITY	City	Single Family Res-Combo
02 103249 RK	CITY	City	SFR-Basic
02 103388 RK	CITY	City	SFR-Basic
02 103250 RK	CITY	City	SFR-Basic
02 103391 RK	CITY	City	SFR-Basic
02 104694 RK	CITY	City	Single Family Res-Combo
02 105350 RK	CITY	City	SFR-Basic
02 105351 RK	CITY	City	SFR-Basic
02 105352 RK	CITY	City	SFR-Basic
02 101192 RK	PRD-7,200	Residential 7,200 sq. ft.	Single Family Res-Combo
02 101186 RK	PRD-7,200	Residential 7,200 sq. ft.	Single Family Res-Combo
02 101488 RK	PRD-7,200	Residential 7,200 sq. ft.	Single Family Res-Combo
02 101191 RK	PRD-7,200	Residential 7,200 sq. ft.	Single Family Res-Combo
02 101187 RK	PRD-7,200	Residential 7,200 sq. ft.	Single Family Res-Combo
02 101193 RK	PRD-7,200	Residential 7,200 sq. ft.	Single Family Res-Combo
02 101183 RK	PRD-7,200	Residential 7,200 sq. ft.	Single Family Res-Combo
02 101188 RK	PRD-7,200	Residential 7,200 sq. ft.	Single Family Res-Combo
02 101185 RK	PRD-7,200	Residential 7,200 sq. ft.	Single Family Res-Combo
02 101516 RK	PRD-7,200	Residential 7,200 sq. ft.	Single Family Res-Combo
02 101184 RK	PRD-7,200	Residential 7,200 sq. ft.	Single Family Res-Combo
02 104337 RK	PRD-7,200	Residential 7,200 sq. ft.	SFR-Basic
02 103860 RK	PRD-7,200	Residential 7,200 sq. ft.	SFR-Basic
02 104339 RK	PRD-7,200	Residential 7,200 sq. ft.	Single Family Res-Combo
02 103532 RK	PRD-7,200	Residential 7,200 sq. ft.	Single Family Res-Combo
02 105419 RK	PRD-7,200	Residential 7,200 sq. ft.	SFR-Basic
02 103859 RK	PRD-7,200	Residential 7,200 sq. ft.	SFR-Basic
02 103861 RK	PRD-7,200	Residential 7,200 sq. ft.	SFR-Basic
02 105420 RK	PRD-7,200	Residential 7,200 sq. ft.	SFR-Basic
02 100784 MH	R-5	Rural-5 Acre	Double Wide
02 109147 RK	R-5	Rural-5 Acre	Single Family Res-Combo
02 103375 RK	CITY	City	Single Family Res-Combo

Accessory Dwelling Units

Index # - File Name: 1.0022 - Single Family Dwellings Data\_Snohomish County.pdf

02 101415 RK	R-9,600	Residential 9,600 sq. ft.	SFR-Basic
02 101414 RK	R-9,600	Residential 9,600 sq. ft.	Single Family Res-Combo
02 101411 RK	R-9,600	Residential 9,600 sq. ft.	Single Family Res-Combo
02 101417 RK	R-9,600	Residential 9,600 sq. ft.	SFR-Basic
02 104095 RK	R-9,600	Residential 9,600 sq. ft.	Single Family Res-Combo
02 101416 RK	R-9,600	Residential 9,600 sq. ft.	SFR-Basic
02 101209 RK	CITY	City	SFR-Basic
02 101208 RK	CITY	City	SFR-Basic
02 101207 RK	CITY	City	SFR-Basic
02 101206 RK	CITY	City	SFR-Basic
02 104194 RK	R-9,600	Residential 9,600 sq. ft.	Single Family Res-Combo
02 101123 RK	LDMR	Low Density Multiple Reside Duplex-Basic	
02 101130 RK	LDMR	Low Density Multiple Reside Duplex-Basic	
02 101141 RK	LDMR	Low Density Multiple Reside Duplex-Basic	
02 101142 RK	LDMR	Low Density Multiple Reside Duplex-Basic	
02 101132 RK	LDMR	Low Density Multiple Reside Duplex-Basic	
02 101125 RK	LDMR	Low Density Multiple Reside Duplex-Basic	
02 101143 RK	LDMR	Low Density Multiple Reside Duplex-Basic	
02 101133 RK	LDMR	Low Density Multiple Reside Duplex-Basic	
02 101144 RK	LDMR	Low Density Multiple Reside Duplex-Basic	
02 101134 RK	LDMR	Low Density Multiple Reside Duplex-Basic	
02 101126 RK	LDMR	Low Density Multiple Reside Duplex-Basic	
02 101127 RK	LDMR	Low Density Multiple Reside Duplex-Basic	
02 101135 RK	LDMR	Low Density Multiple Reside Duplex-Basic	
02 101128 RK	LDMR	Low Density Multiple Reside Duplex-Basic	
02 101137 RK	LDMR	Low Density Multiple Reside Duplex-Basic	
02 101146 RK	LDMR	Low Density Multiple Reside Duplex-Basic	
02 101138 RK	LDMR	Low Density Multiple Reside Duplex-Basic	
02 101147 RK	LDMR	Low Density Multiple Reside Duplex-Basic	
02 101139 RK	LDMR	Low Density Multiple Reside Duplex-Basic	
02 101148 RK	LDMR	Low Density Multiple Reside Duplex-Basic	
02 101145 RK	LDMR	Low Density Multiple Reside Duplex-Basic	
02 105288 RK	R-9,600	Residential 9,600 sq. ft.	Single Family Res-Combo
02 101912 RK	F	Forestry	Single Family Res-Combo
02 101873 RK	R-5	Rural-5 Acre	Single Family Res-Combo
02 109284 RK	R-5	Rural-5 Acre	Single Family Res-Combo
02 109066 MH	R-5	Rural-5 Acre	Double Wide
02 101395 RK	CITY	City	Single Family Res-Combo
02 109814 RK	CITY	City	SFR-Basic
02 109812 RK	CITY	City	SFR-Basic
02 109873 RK	CITY	City	SFR-Basic
02 109870 RK	CITY	City	SFR-Basic
02 103771 RK	CITY	City	Single Family Res-Combo
02 103726 RK	CITY	City	Single Family Res-Combo
02 103870 RK	CITY	City	Single Family Res-Combo
02 103727 RK	CITY	City	Single Family Res-Combo
02 103867 RK	CITY	City	Single Family Res-Combo



Accessory Dwelling Units

Index # - File Name: 1.0022 - Single Family Dwellings Data\_Snohomish County.pdf

02 103728 RK	CITY	City	Single Family Res-Combo
02 101496 RK	CITY	City	Single Family Res-Combo
02 104191 RK	CITY	City	Single Family Res-Combo
02 102016 RK	CITY	City	Duplex-Combo
02 103219 RK	R-7,200	Residential 7,200 sq. ft.	SFR-Basic
02 100444 RK	R-7,200	Residential 7,200 sq. ft.	Single Family Res-Combo
02 100921 RK	R-7,200	Residential 7,200 sq. ft.	Single Family Res-Combo
02 103094 RK	R-7,200	Residential 7,200 sq. ft.	SFR-Basic
02 103099 RK	R-7,200	Residential 7,200 sq. ft.	SFR-Basic
02 104192 RK	CITY	City	Single Family Res-Combo
02 104409 RK	CITY	City	SFR-Basic
02 104733 RK	CITY	City	SFR-Basic
02 104729 RK	CITY	City	SFR-Basic
02 105625 RK	CITY	City	SFR-Basic
02 104777 RK	CITY	City	SFR-Basic
02 104734 RK	CITY	City	SFR-Basic
02 104778 RK	CITY	City	SFR-Basic
02 104779 RK	CITY	City	SFR-Basic
02 104780 RK	CITY	City	SFR-Basic
02 104735 RK	CITY	City	SFR-Basic
02 104753 RK	CITY	City	SFR-Basic
02 104737 RK	CITY	City	SFR-Basic
02 104754 RK	CITY	City	SFR-Basic
02 104730 RK	CITY	City	SFR-Basic
02 104127 RK	CITY	City	Single Family Res-Combo
02 104738 RK	CITY	City	SFR-Basic
02 104756 RK	CITY	City	SFR-Basic
02 104739 RK	CITY	City	SFR-Basic
02 104757 RK	CITY	City	SFR-Basic
02 104731 RK	CITY	City	SFR-Basic
02 104732 RK	CITY	City	SFR-Basic
02 104740 RK	CITY	City	SFR-Basic
02 104759 RK	CITY	City	SFR-Basic
02 104760 RK	CITY	City	SFR-Basic
02 104741 RK	CITY	City	SFR-Basic
02 104742 RK	CITY	City	SFR-Basic
02 104743 RK	CITY	City	SFR-Basic
02 104744 RK	CITY	City	SFR-Basic
02 104761 RK	CITY	City	SFR-Basic
02 104764 RK	CITY	City	SFR-Basic
02 104765 RK	CITY	City	SFR-Basic
02 104766 RK	CITY	City	SFR-Basic
02 104782 RK	CITY	City	SFR-Basic
02 105626 RK	CITY	City	SFR-Basic
02 105627 RK	CITY	City	SFR-Basic
02 105629 RK	CITY	City	SFR-Basic
02 104745 RK	CITY	City	SFR-Basic

Accessory Dwelling Units

Index # - File Name: 1.0022 - Single Family Dwellings Data\_Snohomish County.pdf

02 104767 RK	CITY	City	SFR-Basic
02 104783 RK	CITY	City	SFR-Basic
02 104784 RK	CITY	City	SFR-Basic
02 104969 RK	CITY	City	SFR-Basic
02 109201 RK	CITY	City	SFR-Basic
02 104746 RK	CITY	City	SFR-Basic
02 104768 RK	CITY	City	SFR-Basic
02 104770 RK	CITY	City	SFR-Basic
02 104747 RK	CITY	City	SFR-Basic
02 104748 RK	CITY	City	SFR-Basic
02 104771 RK	CITY	City	SFR-Basic
02 104772 RK	CITY	City	SFR-Basic
02 104776 RK	CITY	City	SFR-Basic
02 104749 RK	CITY	City	SFR-Basic
02 104750 RK	CITY	City	SFR-Basic
02 104773 RK	CITY	City	SFR-Basic
02 104774 RK	CITY	City	SFR-Basic
02 104751 RK	CITY	City	SFR-Basic
02 104752 RK	CITY	City	SFR-Basic
02 104775 RK	CITY	City	SFR-Basic
02 105630 RK	CITY	City	SFR-Basic
02 108093 RK	CITY	City	SFR-Basic
02 108091 RK	CITY	City	SFR-Basic
02 109867 RK	CITY	City	Single Family Res-Combo
02 108088 RK	CITY	City	SFR-Basic
02 107887 RK	CITY	City	SFR-Basic
02 107889 RK	CITY	City	SFR-Basic
02 104397 RK	CITY	City	SFR-Basic
02 104968 RK	CITY	City	SFR-Basic
02 104960 RK	CITY	City	SFR-Basic
02 104967 RK	CITY	City	SFR-Basic
02 104958 RK	CITY	City	SFR-Basic
02 104965 RK	CITY	City	SFR-Basic
02 104966 RK	CITY	City	SFR-Basic
02 104959 RK	CITY	City	SFR-Basic
02 104961 RK	CITY	City	SFR-Basic
02 104970 RK	CITY	City	SFR-Basic
02 104972 RK	CITY	City	SFR-Basic
02 104964 RK	CITY	City	SFR-Basic
02 104388 RK	CITY	City	SFR-Basic
02 104383 RK	CITY	City	SFR-Basic
02 104386 RK	CITY	City	SFR-Basic
02 104387 RK	CITY	City	SFR-Basic
02 104395 RK	CITY	City	SFR-Basic
02 104963 RK	CITY	City	SFR-Basic
02 104962 RK	CITY	City	SFR-Basic
02 104971 RK	CITY	City	SFR-Basic

Accessory Dwelling Units

Index # - File Name: 1.0022 - Single Family Dwellings Data\_Snohomish County.pdf

02 104385 RK	CITY	City	SFR-Basic
02 104391 RK	CITY	City	SFR-Basic
02 104389 RK	CITY	City	SFR-Basic
02 104394 RK	CITY	City	SFR-Basic
02 104402 RK	CITY	City	SFR-Basic
02 104401 RK	CITY	City	SFR-Basic
02 104400 RK	CITY	City	SFR-Basic
02 104399 RK	CITY	City	SFR-Basic
02 104392 RK	CITY	City	SFR-Basic
02 104393 RK	CITY	City	SFR-Basic
02 104398 RK	CITY	City	SFR-Basic
02 108555 RK	CITY	City	SFR-Basic
02 103669 RK	PRD-7,200	Residential 7,200 sq. ft.	SFR-Basic
02 105287 RK	PRD-7,200	Residential 7,200 sq. ft.	Single Family Res-Combo
02 104223 RK	PRD-7,200	Residential 7,200 sq. ft.	Single Family Res-Combo
02 104222 RK	PRD-7,200	Residential 7,200 sq. ft.	Single Family Res-Combo
02 103667 RK	PRD-7,200	Residential 7,200 sq. ft.	SFR-Basic
02 108968 RK	PRD-7,200	Residential 7,200 sq. ft.	SFR-Basic
02 106472 RK	PRD-7,200	Residential 7,200 sq. ft.	SFR-Basic
02 107091 RK	PRD-7,200	Residential 7,200 sq. ft.	SFR-Basic
02 107092 RK	PRD-7,200	Residential 7,200 sq. ft.	SFR-Basic
02 103670 RK	PRD-7,200	Residential 7,200 sq. ft.	SFR-Basic
02 106469 RK	PRD-7,200	Residential 7,200 sq. ft.	SFR-Basic
02 106471 RK	PRD-7,200	Residential 7,200 sq. ft.	SFR-Basic
02 103668 RK	PRD-7,200	Residential 7,200 sq. ft.	SFR-Basic
02 107093 RK	PRD-7,200	Residential 7,200 sq. ft.	SFR-Basic
02 107915 RK	PRD-7,200	Residential 7,200 sq. ft.	SFR-Basic
02 107914 RK	PRD-7,200	Residential 7,200 sq. ft.	SFR-Basic
02 102679 RK	R-5	Rural-5 Acre	Single Family Res-Combo
02 108548 RK	CITY	City	SFR-Basic
02 108553 RK	CITY	City	SFR-Basic
02 108552 RK	CITY	City	SFR-Basic
02 108547 RK	CITY	City	SFR-Basic
02 108551 RK	CITY	City	SFR-Basic
02 108546 RK	CITY	City	SFR-Basic
02 105815 RK	R-5	Rural-5 Acre	SFR-Basic
02 102812 MH	F and R : R-5	Forestry and Recreation : Ru	Single Wide
02 104725 RK	R-5	Rural-5 Acre	Duplex-Combo
02 104505 RK	R-5	Rural-5 Acre	Single Family Res-Combo
02 103336 RK	PRD-9,600	Residential 9,600 sq. ft.	SFR-Basic
02 103350 RK	PRD-9,600	Residential 9,600 sq. ft.	SFR-Basic
02 103345 RK	PRD-9,600	Residential 9,600 sq. ft.	SFR-Basic
02 103351 RK	PRD-9,600	Residential 9,600 sq. ft.	SFR-Basic
02 103353 RK	PRD-9,600	Residential 9,600 sq. ft.	SFR-Basic
02 103327 RK	PRD-9,600	Residential 9,600 sq. ft.	SFR-Basic
02 103332 RK	PRD-9,600	Residential 9,600 sq. ft.	SFR-Basic
02 103346 RK	PRD-9,600	Residential 9,600 sq. ft.	SFR-Basic

Accessory Dwelling Units

Index # - File Name: 1.0022 - Single Family Dwellings Data\_Snohomish County.pdf

02 103341 RK	PRD-9,600	Residential 9,600 sq. ft.	SFR-Basic
02 104088 RK	R-9,600(PRD)	Residential 9,600 sq. ft.	SFR-Basic
02 110345 RK	R-9,600(PRD)	Residential 9,600 sq. ft.	SFR-Basic
02 109695 RK	R-9,600(PRD)	Residential 9,600 sq. ft.	SFR-Basic
02 108344 RK	R-9,600(PRD)	Residential 9,600 sq. ft.	Single Family Res-Combo
02 109696 RK	R-9,600(PRD)	Residential 9,600 sq. ft.	SFR-Basic
02 110344 RK	R-9,600(PRD)	Residential 9,600 sq. ft.	SFR-Basic
02 107892 RK	R-9,600(PRD)	Residential 9,600 sq. ft.	SFR-Basic
02 107460 RK	R-9,600(PRD)	Residential 9,600 sq. ft.	SFR-Basic
02 109418 RK	R-9,600(PRD)	Residential 9,600 sq. ft.	SFR-Basic
02 109076 RK	R-9,600(PRD)	Residential 9,600 sq. ft.	SFR-Basic
02 105151 RK	R-9,600(PRD)	Residential 9,600 sq. ft.	Single Family Res-Combo
02 107893 RK	R-9,600(PRD)	Residential 9,600 sq. ft.	SFR-Basic
02 109419 RK	R-9,600(PRD)	Residential 9,600 sq. ft.	SFR-Basic
02 105823 RK	R-9,600(PRD)	Residential 9,600 sq. ft.	SFR-Basic
02 105825 RK	R-9,600(PRD)	Residential 9,600 sq. ft.	SFR-Basic
02 105824 RK	R-9,600(PRD)	Residential 9,600 sq. ft.	SFR-Basic
02 103744 RK	R-9,600(PRD)	Residential 9,600 sq. ft.	Single Family Res-Combo
02 105822 RK	R-9,600(PRD)	Residential 9,600 sq. ft.	SFR-Basic
02 109070 RK	R-9,600(PRD)	Residential 9,600 sq. ft.	SFR-Basic
02 109075 RK	R-9,600(PRD)	Residential 9,600 sq. ft.	SFR-Basic
02 108354 RK	R-9,600(PRD)	Residential 9,600 sq. ft.	SFR-Basic
02 108343 RK	R-9,600(PRD)	Residential 9,600 sq. ft.	Single Family Res-Combo
02 109073 RK	R-9,600(PRD)	Residential 9,600 sq. ft.	SFR-Basic
02 109071 RK	R-9,600(PRD)	Residential 9,600 sq. ft.	SFR-Basic
02 109069 RK	R-9,600(PRD)	Residential 9,600 sq. ft.	SFR-Basic
02 105156 RK	R-9,600(PRD)	Residential 9,600 sq. ft.	SFR-Basic
02 105155 RK	R-9,600(PRD)	Residential 9,600 sq. ft.	SFR-Basic
02 105154 RK	R-9,600(PRD)	Residential 9,600 sq. ft.	SFR-Basic
02 105153 RK	R-9,600(PRD)	Residential 9,600 sq. ft.	SFR-Basic
02 105152 RK	R-9,600(PRD)	Residential 9,600 sq. ft.	SFR-Basic
02 104093 RK	R-9,600(PRD)	Residential 9,600 sq. ft.	SFR-Basic
02 109969 RK	R-5	Rural-5 Acre	Single Family Res-Combo
02 108332 RK	R-5	Rural-5 Acre	SFR-Basic
02 105279 RK	CITY	City	Single Family Res-Combo
02 104698 RK	CITY	City	Single Family Res-Combo
02 104706 RK	CITY	City	Single Family Res-Combo
02 104700 RK	CITY	City	Single Family Res-Combo
02 103838 RK	CITY	City	Single Family Res-Combo
02 105280 RK	CITY	City	Single Family Res-Combo
02 105282 RK	CITY	City	Single Family Res-Combo
02 105276 RK	CITY	City	Single Family Res-Combo
02 104701 RK	CITY	City	Single Family Res-Combo
02 105278 RK	CITY	City	Single Family Res-Combo
02 104705 RK	CITY	City	Single Family Res-Combo
02 104702 RK	CITY	City	Single Family Res-Combo
02 104708 RK	CITY	City	Single Family Res-Combo

Accessory Dwelling Units

Index # - File Name: 1.0022 - Single Family Dwellings Data\_Snohomish County.pdf

02 104703 RK	CITY	City	Single Family Res-Combo
02 104704 RK	CITY	City	Single Family Res-Combo
02 104707 RK	CITY	City	Single Family Res-Combo
02 105281 RK	CITY	City	Single Family Res-Combo
02 104258 RK	CITY	City	Single Family Res-Combo
02 104266 RK	CITY	City	Single Family Res-Combo
02 104255 RK	CITY	City	Single Family Res-Combo
02 104271 RK	CITY	City	Single Family Res-Combo
02 103837 RK	CITY	City	Single Family Res-Combo
02 103839 RK	CITY	City	Single Family Res-Combo
02 103835 RK	CITY	City	Single Family Res-Combo
02 103083 RK	R-5	Rural-5 Acre	Single Family Res-Combo
02 107464 RK	CITY	City	Duplex-Basic
02 107463 RK	CITY	City	Duplex-Basic
02 107446 RK	CITY	City	Duplex-Basic
02 107444 RK	CITY	City	Duplex-Basic
02 103088 RK	R-5	Rural-5 Acre	Single Family Res-Combo
02 103090 RK	R-5	Rural-5 Acre	Single Family Res-Combo
02 109417 RK	R-9,600(PRD)	Residential 9,600 sq. ft.	SFR-Basic
02 104089 RK	R-9,600(PRD)	Residential 9,600 sq. ft.	SFR-Basic
02 104090 RK	R-9,600(PRD)	Residential 9,600 sq. ft.	SFR-Basic
02 104092 RK	R-9,600(PRD)	Residential 9,600 sq. ft.	SFR-Basic
02 103854 RK	R-5	Rural-5 Acre	Single Family Res-Combo
02 103802 RK	R-5	Rural-5 Acre	Single Family Res-Combo
02 103896 RK	R-5	Rural-5 Acre	Single Family Res-Combo
02 103801 RK	R-5	Rural-5 Acre	Single Family Res-Combo
02 103897 RK	R-5	Rural-5 Acre	Single Family Res-Combo
02 108341 RK	R-5	Rural-5 Acre	SFR-Basic
02 104905 RK	R-5	Rural-5 Acre	SFR-Basic
02 104054 RK	CITY	City	SFR-Basic
02 105516 RK	CITY	City	SFR-Basic
02 101579 RK	CITY	City	Single Family Res-Combo
02 104619 RK	CITY	City	SFR-Basic
02 104624 RK	CITY	City	SFR-Basic
02 104148 RK	CITY	City	SFR-Basic
02 105525 RK	CITY	City	SFR-Basic
02 105524 RK	CITY	City	SFR-Basic
02 104631 RK	CITY	City	Single Family Res-Combo
02 105515 RK	CITY	City	Single Family Res-Combo
02 104628 RK	CITY	City	SFR-Basic
02 104630 RK	CITY	City	SFR-Basic
02 105521 RK	CITY	City	SFR-Basic
02 105523 RK	CITY	City	SFR-Basic
02 105519 RK	CITY	City	SFR-Basic
02 101577 RK	CITY	City	Single Family Res-Combo
02 104620 RK	CITY	City	SFR-Basic
02 105522 RK	CITY	City	SFR-Basic

Accessory Dwelling Units

Index # - File Name: 1.0022 - Single Family Dwellings Data\_Snohomish County.pdf

02 105520 RK	CITY	City	SFR-Basic
02 104625 RK	CITY	City	SFR-Basic
02 104634 RK	CITY	City	SFR-Basic
02 104621 RK	CITY	City	SFR-Basic
02 101578 RK	CITY	City	Single Family Res-Combo
02 104633 RK	CITY	City	SFR-Basic
02 101576 RK	CITY	City	Single Family Res-Combo
02 104626 RK	CITY	City	SFR-Basic
02 104055 RK	CITY	City	SFR-Basic
02 104056 RK	CITY	City	SFR-Basic
02 104057 RK	CITY	City	SFR-Basic
02 104058 RK	CITY	City	SFR-Basic
02 104822 RK	PRD-7,200	Residential 7,200 sq. ft.	SFR-Basic
02 104828 RK	PRD-7,200	Residential 7,200 sq. ft.	SFR-Basic
02 101231 RK	PRD-7,200	Residential 7,200 sq. ft.	Single Family Res-Combo
02 104834 RK	PRD-7,200	Residential 7,200 sq. ft.	SFR-Basic
02 104823 RK	PRD-7,200	Residential 7,200 sq. ft.	SFR-Basic
02 101693 RK	PRD-7,200	Residential 7,200 sq. ft.	Single Family Res-Combo
00 108629 RK	PRD-7,200	Residential 7,200 sq. ft.	Single Family Res-Combo
02 101230 RK	PRD-7,200	Residential 7,200 sq. ft.	Single Family Res-Combo
02 104832 RK	PRD-7,200	Residential 7,200 sq. ft.	SFR-Basic
02 104824 RK	PRD-7,200	Residential 7,200 sq. ft.	SFR-Basic
02 101697 RK	PRD-7,200	Residential 7,200 sq. ft.	Single Family Res-Combo
02 104825 RK	PRD-7,200	Residential 7,200 sq. ft.	SFR-Basic
00 107084 RK	PRD-7,200	Residential 7,200 sq. ft.	Single Family Res-Combo
02 104829 RK	PRD-7,200	Residential 7,200 sq. ft.	SFR-Basic
02 104837 RK	PRD-7,200	Residential 7,200 sq. ft.	SFR-Basic
02 105946 RK	PRD-7,200	Residential 7,200 sq. ft.	SFR-Basic
02 104831 RK	PRD-7,200	Residential 7,200 sq. ft.	SFR-Basic
02 104826 RK	PRD-7,200	Residential 7,200 sq. ft.	SFR-Basic
02 104836 RK	PRD-7,200	Residential 7,200 sq. ft.	SFR-Basic
02 104827 RK	PRD-7,200	Residential 7,200 sq. ft.	SFR-Basic
02 104835 RK	PRD-7,200	Residential 7,200 sq. ft.	SFR-Basic
02 103753 RK	R-8,400	Residential 8,400 sq. ft.	SFR-Basic
02 108134 RK	R-9,600	Residential 9,600 sq. ft.	Single Family Res-Combo
02 108133 RK	R-9,600	Residential 9,600 sq. ft.	Single Family Res-Combo
02 103799 MH	F	Forestry	Double Wide
02 108391 RK	R-5	Rural-5 Acre	Single Family Res-Combo
02 104903 RK	R-5	Rural-5 Acre	SFR-Basic
02 107379 RK	R-5	Rural-5 Acre	SFR-Basic
02 103374 RK	R-5	Rural-5 Acre	Single Family Res-Combo
02 107638 RK	F	Forestry	Single Family Res-Combo
02 103895 RK	R-5	Rural-5 Acre	Single Family Res-Combo
02 105762 RK	CITY	City	Duplex-Basic
02 107299 MH	R-5	Rural-5 Acre	Double Wide
02 104135 RK	R-5	Rural-5 Acre	Single Family Res-Combo
02 104210 RK	R-5	Rural-5 Acre	Single Family Res-Combo

Accessory Dwelling Units

Index # - File Name: 1.0022 - Single Family Dwellings Data\_Snohomish County.pdf

02 104305 RK	RRT-10	Rural Resource Transition-10	Single Family Res-Combo
02 104341 RK	R-5	Rural-5 Acre	Single Family Res-Combo
02 109065 MH	R-5	Rural-5 Acre	Double Wide
02 104453 RK	R-5	Rural-5 Acre	Single Family Res-Combo
02 107050 RK	R-5	Rural-5 Acre	Single Family Res-Combo
02 104580 RK	R-5	Rural-5 Acre	Single Family Res-Combo
02 104614 RK	R-9,600	Residential 9,600 sq. ft.	Single Family Res-Combo
02 104653 RK	R-5	Rural-5 Acre	Single Family Res-Combo
02 104693 RK	R-5	Rural-5 Acre	Single Family Res-Combo
02 106238 RK	CITY	City	Single Family Res-Combo
02 107549 RK	CITY	City	SFR-Basic
02 104591 RK	PRD-9,600	Residential 9,600 sq. ft.	SFR-Basic
02 104577 RK	PRD-9,600	Residential 9,600 sq. ft.	SFR-Basic
02 104572 RK	PRD-9,600	Residential 9,600 sq. ft.	SFR-Basic
02 104582 RK	PRD-9,600	Residential 9,600 sq. ft.	SFR-Basic
02 104573 RK	PRD-9,600	Residential 9,600 sq. ft.	SFR-Basic
02 104588 RK	PRD-9,600	Residential 9,600 sq. ft.	SFR-Basic
02 104594 RK	PRD-9,600	Residential 9,600 sq. ft.	SFR-Basic
02 104569 RK	PRD-9,600	Residential 9,600 sq. ft.	SFR-Basic
02 104583 RK	PRD-9,600	Residential 9,600 sq. ft.	SFR-Basic
02 104574 RK	PRD-9,600	Residential 9,600 sq. ft.	SFR-Basic
02 104584 RK	PRD-9,600	Residential 9,600 sq. ft.	SFR-Basic
02 104589 RK	PRD-9,600	Residential 9,600 sq. ft.	SFR-Basic
02 104595 RK	PRD-9,600	Residential 9,600 sq. ft.	SFR-Basic
02 104585 RK	PRD-9,600	Residential 9,600 sq. ft.	SFR-Basic
02 104596 RK	PRD-9,600	Residential 9,600 sq. ft.	SFR-Basic
02 104590 RK	PRD-9,600	Residential 9,600 sq. ft.	SFR-Basic
02 104575 RK	PRD-9,600	Residential 9,600 sq. ft.	SFR-Basic
02 104570 RK	PRD-9,600	Residential 9,600 sq. ft.	SFR-Basic
02 102769 RK	R-7,200	Residential 7,200 sq. ft.	Single Family Res-Combo
02 103689 RK	R-7,200	Residential 7,200 sq. ft.	Single Family Res-Combo
02 102677 RK	R-7,200	Residential 7,200 sq. ft.	Single Family Res-Combo
02 102770 RK	R-7,200	Residential 7,200 sq. ft.	Single Family Res-Combo
02 103688 RK	R-7,200	Residential 7,200 sq. ft.	Single Family Res-Combo
02 102771 RK	R-7,200	Residential 7,200 sq. ft.	Single Family Res-Combo
02 104686 RK	R-7,200	Residential 7,200 sq. ft.	Single Family Res-Combo
02 104687 RK	R-7,200	Residential 7,200 sq. ft.	Single Family Res-Combo
02 104688 RK	R-7,200	Residential 7,200 sq. ft.	Single Family Res-Combo
02 104689 RK	R-7,200	Residential 7,200 sq. ft.	Single Family Res-Combo
02 104690 RK	R-7,200	Residential 7,200 sq. ft.	Single Family Res-Combo
02 105037 RK	R-7,200	Residential 7,200 sq. ft.	Single Family Res-Combo
02 105038 RK	R-7,200	Residential 7,200 sq. ft.	Single Family Res-Combo
02 105040 RK	R-7,200	Residential 7,200 sq. ft.	Single Family Res-Combo
02 105041 RK	R-7,200	Residential 7,200 sq. ft.	Single Family Res-Combo
02 105042 RK	R-7,200	Residential 7,200 sq. ft.	Single Family Res-Combo
02 105043 RK	R-7,200	Residential 7,200 sq. ft.	Single Family Res-Combo
02 105044 RK	R-7,200	Residential 7,200 sq. ft.	Single Family Res-Combo

Accessory Dwelling Units

Index # - File Name: 1.0022 - Single Family Dwellings Data\_Snohomish County.pdf

02 105373 RK	R-7,200	Residential 7,200 sq. ft.	Single Family Res-Combo
02 105375 RK	R-7,200	Residential 7,200 sq. ft.	Single Family Res-Combo
02 105376 RK	R-7,200	Residential 7,200 sq. ft.	Single Family Res-Combo
02 105377 RK	R-7,200	Residential 7,200 sq. ft.	Single Family Res-Combo
02 105378 RK	R-7,200	Residential 7,200 sq. ft.	Single Family Res-Combo
02 102678 RK	R-7,200	Residential 7,200 sq. ft.	Single Family Res-Combo
02 103687 RK	R-7,200	Residential 7,200 sq. ft.	Single Family Res-Combo
02 102772 RK	R-7,200	Residential 7,200 sq. ft.	Single Family Res-Combo
02 102773 RK	R-7,200	Residential 7,200 sq. ft.	Single Family Res-Combo
02 102774 RK	R-7,200	Residential 7,200 sq. ft.	Single Family Res-Combo
02 103686 RK	R-7,200	Residential 7,200 sq. ft.	Single Family Res-Combo
02 104691 RK	R-7,200	Residential 7,200 sq. ft.	Single Family Res-Combo
02 104692 RK	R-7,200	Residential 7,200 sq. ft.	Single Family Res-Combo
02 105029 RK	R-5	Rural-5 Acre	Single Family Res-Combo
02 105261 RK	R-9,600	Residential 9,600 sq. ft.	SFR-Basic
02 110119 RK	R-9,600	Residential 9,600 sq. ft.	SFR-Basic
02 109886 RK	PRD-7,200	Residential 7,200 sq. ft.	SFR-Basic
02 109887 RK	PRD-7,200	Residential 7,200 sq. ft.	SFR-Basic
02 109548 RK	PRD-7,200	Residential 7,200 sq. ft.	SFR-Basic
02 108843 RK	PRD-7,200	Residential 7,200 sq. ft.	SFR-Basic
02 108844 RK	PRD-7,200	Residential 7,200 sq. ft.	SFR-Basic
02 103364 RK	PRD-7,200	Residential 7,200 sq. ft.	Single Family Res-Combo
02 109890 RK	PRD-7,200	Residential 7,200 sq. ft.	SFR-Basic
02 109891 RK	PRD-7,200	Residential 7,200 sq. ft.	SFR-Basic
02 109229 RK	PRD-7,200	Residential 7,200 sq. ft.	SFR-Basic
02 107966 RK	PRD-7,200	Residential 7,200 sq. ft.	SFR-Basic
02 102845 RK	PRD-7,200	Residential 7,200 sq. ft.	Single Family Res-Combo
02 107554 RK	PRD-7,200	Residential 7,200 sq. ft.	SFR-Basic
02 109228 RK	PRD-7,200	Residential 7,200 sq. ft.	SFR-Basic
02 109547 RK	PRD-7,200	Residential 7,200 sq. ft.	SFR-Basic
02 108318 RK	PRD-7,200	Residential 7,200 sq. ft.	SFR-Basic
02 107556 RK	PRD-7,200	Residential 7,200 sq. ft.	SFR-Basic
02 105562 RK	R-5	Rural-5 Acre	Single Family Res-Combo
02 105631 MH	RRT-10	Rural Resource Transition-10	Double Wide
02 105655 MH	R-5	Rural-5 Acre	Triple Wide
02 105681 MH	R-5	Rural-5 Acre	Double Wide
02 105976 RK	CITY	City	SFR-Basic
02 107562 RK	R-7,200	Residential 7,200 sq. ft.	SFR-Basic
02 106992 RK	R-7,200	Residential 7,200 sq. ft.	Single Family Res-Combo
02 107139 RK	R-7,200	Residential 7,200 sq. ft.	SFR-Basic
02 107330 RK	R-7,200	Residential 7,200 sq. ft.	SFR-Basic
02 108761 RK	R-7,200	Residential 7,200 sq. ft.	SFR-Basic
02 107711 RK	R-7,200	Residential 7,200 sq. ft.	SFR-Basic
02 107231 RK	R-7,200	Residential 7,200 sq. ft.	SFR-Basic
02 107234 RK	R-7,200	Residential 7,200 sq. ft.	SFR-Basic
02 108479 RK	R-7,200	Residential 7,200 sq. ft.	Single Family Res-Combo
02 107331 RK	R-7,200	Residential 7,200 sq. ft.	SFR-Basic



Accessory Dwelling Units

Index # - File Name: 1.0022 - Single Family Dwellings Data\_Snohomish County.pdf

02 107560 RK	R-7,200	Residential 7,200 sq. ft.	SFR-Basic
02 107141 RK	R-7,200	Residential 7,200 sq. ft.	SFR-Basic
02 108482 RK	R-7,200	Residential 7,200 sq. ft.	Single Family Res-Combo
02 110013 RK	CITY	City	SFR-Basic
02 110199 RK	CITY	City	SFR-Basic
02 110195 RK	CITY	City	SFR-Basic
02 109323 RK	CITY	City	Single Family Res-Combo
02 110309 RK	CITY	City	SFR-Basic
02 109839 RK	CITY	City	SFR-Basic
02 110016 RK	CITY	City	SFR-Basic
02 109181 RK	CITY	City	Single Family Res-Combo
02 109845 RK	CITY	City	SFR-Basic
02 110307 RK	CITY	City	SFR-Basic
02 110021 RK	CITY	City	SFR-Basic
02 110022 RK	CITY	City	SFR-Basic
02 110019 RK	CITY	City	SFR-Basic
02 105969 RK	R-8,400	Residential 8,400 sq. ft.	SFR-Basic
02 105971 RK	R-8,400	Residential 8,400 sq. ft.	SFR-Basic
02 105966 RK	R-8,400	Residential 8,400 sq. ft.	SFR-Basic
02 108612 RK	R-7,200	Residential 7,200 sq. ft.	SFR-Basic
02 109248 RK	R-7,200	Residential 7,200 sq. ft.	Single Family Res-Combo
02 108257 RK	R-7,200	Residential 7,200 sq. ft.	Single Family Res-Combo
02 110128 RK	R-7,200	Residential 7,200 sq. ft.	SFR-Basic
02 107761 RK	R-7,200	Residential 7,200 sq. ft.	Single Family Res-Combo
02 107760 RK	R-7,200	Residential 7,200 sq. ft.	Single Family Res-Combo
02 107862 RK	R-7,200	Residential 7,200 sq. ft.	Single Family Res-Combo
02 107759 RK	R-7,200	Residential 7,200 sq. ft.	Single Family Res-Combo
02 107861 RK	R-7,200	Residential 7,200 sq. ft.	Single Family Res-Combo
02 107865 RK	R-7,200	Residential 7,200 sq. ft.	Single Family Res-Combo
02 106624 RK	R-7,200	Residential 7,200 sq. ft.	Single Family Res-Combo
02 106623 RK	R-7,200	Residential 7,200 sq. ft.	Single Family Res-Combo
02 109247 RK	R-7,200	Residential 7,200 sq. ft.	SFR-Basic
02 107204 RK	R-7,200	Residential 7,200 sq. ft.	SFR-Basic
02 107206 RK	R-7,200	Residential 7,200 sq. ft.	Single Family Res-Combo
02 106294 RK	F	Forestry	Single Family Res-Combo
02 106162 RK	RRT-10	Rural Resource Transition-10	Single Family Res-Combo
02 107068 RK	R-7,200	Residential 7,200 sq. ft.	Single Family Res-Combo
02 105577 RK	MR	Multiple Residential	SFR-Basic
02 105607 RK	MR	Multiple Residential	SFR-Basic
02 105578 RK	MR	Multiple Residential	SFR-Basic
01 112920 RK	MR	Multiple Residential	Single Family Res-Combo
02 105590 RK	MR	Multiple Residential	SFR-Basic
02 105608 RK	MR	Multiple Residential	SFR-Basic
02 105595 RK	MR	Multiple Residential	SFR-Basic
02 105591 RK	MR	Multiple Residential	SFR-Basic
02 105579 RK	MR	Multiple Residential	SFR-Basic
02 105603 RK	MR	Multiple Residential	SFR-Basic

Accessory Dwelling Units

Index # - File Name: 1.0022 - Single Family Dwellings Data\_Snohomish County.pdf

02 105592 RK	MR	Multiple Residential	SFR-Basic
02 105609 RK	MR	Multiple Residential	SFR-Basic
02 105597 RK	MR	Multiple Residential	SFR-Basic
02 105580 RK	MR	Multiple Residential	SFR-Basic
02 105593 RK	MR	Multiple Residential	SFR-Basic
02 105581 RK	MR	Multiple Residential	SFR-Basic
02 105600 RK	MR	Multiple Residential	SFR-Basic
02 105582 RK	MR	Multiple Residential	SFR-Basic
02 105589 RK	MR	Multiple Residential	SFR-Basic
02 107645 RK	R-7,200	Residential 7,200 sq. ft.	SFR-Basic
02 107208 RK	R-7,200	Residential 7,200 sq. ft.	SFR-Basic
02 106281 MH	RRT-10	Rural Resource Transition-10(Double Wide	
02 106282 MH	RRT-10	Rural Resource Transition-10(Double Wide	
02 106293 MH	R-5	Rural-5 Acre	Double Wide
02 108856 RK	F	Forestry	Single Family Res-Combo
02 106318 RK	R-5	Rural-5 Acre	Duplex-Basic
02 105583 RK	MR	Multiple Residential	SFR-Basic
02 105594 RK	MR	Multiple Residential	SFR-Basic
02 105604 RK	MR	Multiple Residential	SFR-Basic
02 105587 RK	MR	Multiple Residential	SFR-Basic
01 112917 RK	MR	Multiple Residential	Single Family Res-Combo
02 105614 RK	MR	Multiple Residential	SFR-Basic
01 112792 RK	MR	Multiple Residential	Single Family Res-Combo
01 107878 RK	MR	Multiple Residential	Single Family Res-Combo
01 112919 RK	MR	Multiple Residential	Single Family Res-Combo
02 105615 RK	MR	Multiple Residential	SFR-Basic
02 105588 RK	MR	Multiple Residential	SFR-Basic
02 105606 RK	MR	Multiple Residential	SFR-Basic
02 105602 RK	MR	Multiple Residential	SFR-Basic
02 106525 RK	R-5	Rural-5 Acre	Single Family Res-Combo
02 108608 RK	PRD-7,200	Residential 7,200 sq. ft.	Single Family Res-Combo
02 107919 RK	PRD-7,200	Residential 7,200 sq. ft.	SFR-Basic
02 108790 RK	PRD-7,200	Residential 7,200 sq. ft.	Single Family Res-Combo
02 107921 RK	PRD-7,200	Residential 7,200 sq. ft.	SFR-Basic
02 108051 RK	PRD-7,200	Residential 7,200 sq. ft.	SFR-Basic
02 109668 RK	PRD-7,200	Residential 7,200 sq. ft.	SFR-Basic
02 106904 MH	R-5	Rural-5 Acre	Double Wide
02 108310 RK	PRD-7,200	Residential 7,200 sq. ft.	Single Family Res-Combo
02 108050 RK	PRD-7,200	Residential 7,200 sq. ft.	SFR-Basic
02 109729 RK	PRD-7,200	Residential 7,200 sq. ft.	SFR-Basic
02 108764 RK	PRD-7,200	Residential 7,200 sq. ft.	SFR-Basic
02 108593 RK	PRD-7,200	Residential 7,200 sq. ft.	SFR-Basic
02 109455 RK	PRD-7,200	Residential 7,200 sq. ft.	SFR-Basic
02 108763 RK	PRD-7,200	Residential 7,200 sq. ft.	SFR-Basic
02 109670 RK	PRD-7,200	Residential 7,200 sq. ft.	SFR-Basic
02 108049 RK	PRD-7,200	Residential 7,200 sq. ft.	SFR-Basic
02 109836 RK	PRD-7,200	Residential 7,200 sq. ft.	SFR-Basic

Accessory Dwelling Units

Index # - File Name: 1.0022 - Single Family Dwellings Data\_Snohomish County.pdf

02 107311 RK	R-7,200	Residential 7,200 sq. ft.	Single Family Res-Combo
02 107427 RK	R-7,200	Residential 7,200 sq. ft.	Single Family Res-Combo
02 107309 RK	R-7,200	Residential 7,200 sq. ft.	Single Family Res-Combo
02 108446 RK	R-7,200	Residential 7,200 sq. ft.	SFR-Basic
02 108445 RK	R-7,200	Residential 7,200 sq. ft.	SFR-Basic
02 107191 RK	R-7,200	Residential 7,200 sq. ft.	Single Family Res-Combo
02 108529 RK	R-7,200	Residential 7,200 sq. ft.	SFR-Basic
02 108530 RK	R-7,200	Residential 7,200 sq. ft.	SFR-Basic
02 107426 RK	R-7,200	Residential 7,200 sq. ft.	Single Family Res-Combo
02 107512 RK	R-7,200	Residential 7,200 sq. ft.	SFR-Basic
02 108528 RK	R-7,200	Residential 7,200 sq. ft.	SFR-Basic
02 108364 RK	PRD-7,200	Residential 7,200 sq. ft.	Single Family Res-Combo
02 109552 RK	PRD-7,200	Residential 7,200 sq. ft.	SFR-Basic
02 107858 RK	PRD-7,200	Residential 7,200 sq. ft.	Single Family Res-Combo
02 109274 RK	PRD-7,200	Residential 7,200 sq. ft.	SFR-Basic
02 106951 RK	PRD-7,200	Residential 7,200 sq. ft.	Single Family Res-Combo
02 106953 RK	PRD-7,200	Residential 7,200 sq. ft.	Single Family Res-Combo
02 106941 RK	PRD-7,200	Residential 7,200 sq. ft.	Single Family Res-Combo
02 106943 RK	PRD-7,200	Residential 7,200 sq. ft.	Single Family Res-Combo
02 106937 RK	PRD-7,200	Residential 7,200 sq. ft.	Single Family Res-Combo
02 106940 RK	PRD-7,200	Residential 7,200 sq. ft.	Single Family Res-Combo
02 106948 RK	PRD-7,200	Residential 7,200 sq. ft.	Single Family Res-Combo
02 106949 RK	PRD-7,200	Residential 7,200 sq. ft.	Single Family Res-Combo
02 106944 RK	PRD-7,200	Residential 7,200 sq. ft.	Single Family Res-Combo
02 106942 RK	PRD-7,200	Residential 7,200 sq. ft.	Single Family Res-Combo
02 106945 RK	PRD-7,200	Residential 7,200 sq. ft.	Single Family Res-Combo
02 107885 RK	PRD-7,200	Residential 7,200 sq. ft.	Single Family Res-Combo
02 109731 RK	PRD-7,200	Residential 7,200 sq. ft.	SFR-Basic
02 108953 RK	PRD-7,200	Residential 7,200 sq. ft.	SFR-Basic
02 108955 RK	PRD-7,200	Residential 7,200 sq. ft.	SFR-Basic
02 109456 RK	PRD-7,200	Residential 7,200 sq. ft.	SFR-Basic
02 108248 RK	R-7,200	Residential 7,200 sq. ft.	Single Family Res-Combo
02 108253 RK	R-7,200	Residential 7,200 sq. ft.	Single Family Res-Combo
02 107043 RK	R-7,200	Residential 7,200 sq. ft.	Single Family Res-Combo
02 109633 RK	R-7,200	Residential 7,200 sq. ft.	SFR-Basic
02 109467 RK	R-7,200	Residential 7,200 sq. ft.	SFR-Basic
02 108251 RK	R-7,200	Residential 7,200 sq. ft.	Single Family Res-Combo
02 108124 RK	R-7,200	Residential 7,200 sq. ft.	SFR-Basic
02 107046 RK	R-7,200	Residential 7,200 sq. ft.	Single Family Res-Combo
02 107923 RK	R-7,200	Residential 7,200 sq. ft.	Single Family Res-Combo
02 107911 RK	R-7,200	Residential 7,200 sq. ft.	Single Family Res-Combo
02 107909 RK	R-7,200	Residential 7,200 sq. ft.	Single Family Res-Combo
02 108269 RK	R-7,200	Residential 7,200 sq. ft.	Single Family Res-Combo
02 107924 RK	R-7,200	Residential 7,200 sq. ft.	Single Family Res-Combo
02 107045 RK	R-7,200	Residential 7,200 sq. ft.	Single Family Res-Combo
02 108503 RK	R-7,200	Residential 7,200 sq. ft.	Single Family Res-Combo
02 110238 RK	R-7,200	Residential 7,200 sq. ft.	SFR-Basic

Accessory Dwelling Units

Index # - File Name: 1.0022 - Single Family Dwellings Data\_Snohomish County.pdf

02 110234 RK	R-7,200	Residential 7,200 sq. ft.	SFR-Basic
02 107044 RK	R-7,200	Residential 7,200 sq. ft.	Single Family Res-Combo
02 107263 RK	PRD-9,600	Residential 9,600 sq. ft.	SFR-Basic
02 107264 RK	PRD-9,600	Residential 9,600 sq. ft.	SFR-Basic
02 107266 RK	PRD-9,600	Residential 9,600 sq. ft.	SFR-Basic
02 107267 RK	PRD-9,600	Residential 9,600 sq. ft.	SFR-Basic
02 107268 RK	PRD-9,600	Residential 9,600 sq. ft.	SFR-Basic
02 107269 RK	PRD-9,600	Residential 9,600 sq. ft.	SFR-Basic
02 109077 RK	PRD-9,600	Residential 9,600 sq. ft.	SFR-Basic
02 109412 RK	PRD-9,600	Residential 9,600 sq. ft.	SFR-Basic
02 107265 RK	PRD-9,600	Residential 9,600 sq. ft.	SFR-Basic
02 109413 RK	PRD-9,600	Residential 9,600 sq. ft.	SFR-Basic
02 108349 RK	PRD-9,600	Residential 9,600 sq. ft.	SFR-Basic
02 109078 RK	PRD-9,600	Residential 9,600 sq. ft.	SFR-Basic
02 109079 RK	PRD-9,600	Residential 9,600 sq. ft.	SFR-Basic
02 108353 RK	PRD-9,600	Residential 9,600 sq. ft.	SFR-Basic
02 107891 RK	PRD-9,600	Residential 9,600 sq. ft.	SFR-Basic
02 107890 RK	PRD-9,600	Residential 9,600 sq. ft.	SFR-Basic
02 108351 RK	PRD-9,600	Residential 9,600 sq. ft.	SFR-Basic
02 108350 RK	PRD-9,600	Residential 9,600 sq. ft.	SFR-Basic
02 109414 RK	PRD-9,600	Residential 9,600 sq. ft.	SFR-Basic
02 109415 RK	PRD-9,600	Residential 9,600 sq. ft.	SFR-Basic
02 109416 RK	PRD-9,600	Residential 9,600 sq. ft.	SFR-Basic
02 108419 RK	PRD-7,200	Residential 7,200 sq. ft.	SFR-Basic
02 108422 RK	PRD-7,200	Residential 7,200 sq. ft.	SFR-Basic
02 110064 RK	PRD-7,200	Residential 7,200 sq. ft.	SFR-Basic
02 109384 RK	PRD-7,200	Residential 7,200 sq. ft.	SFR-Basic
02 110065 RK	PRD-7,200	Residential 7,200 sq. ft.	SFR-Basic
02 110074 RK	PRD-7,200	Residential 7,200 sq. ft.	SFR-Basic
02 108291 RK	PRD-7,200	Residential 7,200 sq. ft.	SFR-Basic
02 108293 RK	PRD-7,200	Residential 7,200 sq. ft.	SFR-Basic
02 108295 RK	PRD-7,200	Residential 7,200 sq. ft.	SFR-Basic
02 108296 RK	PRD-7,200	Residential 7,200 sq. ft.	SFR-Basic
02 108292 RK	PRD-7,200	Residential 7,200 sq. ft.	SFR-Basic
02 108358 RK	PRD-7,200	Residential 7,200 sq. ft.	SFR-Basic
02 108294 RK	PRD-7,200	Residential 7,200 sq. ft.	SFR-Basic
02 108298 RK	PRD-7,200	Residential 7,200 sq. ft.	SFR-Basic
02 108299 RK	PRD-7,200	Residential 7,200 sq. ft.	SFR-Basic
02 108300 RK	PRD-7,200	Residential 7,200 sq. ft.	SFR-Basic
02 108420 RK	PRD-7,200	Residential 7,200 sq. ft.	SFR-Basic
02 108118 RK	RD	Rural Diversification	Single Family Res-Combo
02 108574 RK	RD	Rural Diversification	Single Family Res-Combo
02 108572 RK	RD	Rural Diversification	Single Family Res-Combo
02 108121 RK	RD	Rural Diversification	SFR-Basic
02 108120 RK	RD	Rural Diversification	SFR-Basic
02 108119 RK	RD	Rural Diversification	SFR-Basic
02 107537 RK	PRD-9,600	Residential 9,600 sq. ft.	SFR-Basic

Accessory Dwelling Units

Index # - File Name: 1.0022 - Single Family Dwellings Data\_Snohomish County.pdf

02 107544 RK	PRD-9,600	Residential 9,600 sq. ft.	SFR-Basic
02 107538 RK	PRD-9,600	Residential 9,600 sq. ft.	SFR-Basic
02 107540 RK	PRD-9,600	Residential 9,600 sq. ft.	SFR-Basic
02 107542 RK	PRD-9,600	Residential 9,600 sq. ft.	SFR-Basic
02 107539 RK	PRD-9,600	Residential 9,600 sq. ft.	SFR-Basic
02 107545 RK	PRD-9,600	Residential 9,600 sq. ft.	SFR-Basic
02 107541 RK	PRD-9,600	Residential 9,600 sq. ft.	SFR-Basic
02 107543 RK	PRD-9,600	Residential 9,600 sq. ft.	SFR-Basic
02 107910 RK	PRD-7,200	Residential 7,200 sq. ft.	SFR-Basic
02 108073 RK	PRD-9,600	Residential 9,600 sq. ft.	Single Family Res-Combo
02 109377 RK	PRD-9,600	Residential 9,600 sq. ft.	SFR-Basic
02 110042 RK	PRD-9,600	Residential 9,600 sq. ft.	SFR-Basic
02 110043 RK	PRD-9,600	Residential 9,600 sq. ft.	SFR-Basic
02 110045 RK	PRD-9,600	Residential 9,600 sq. ft.	SFR-Basic
02 109379 RK	PRD-9,600	Residential 9,600 sq. ft.	SFR-Basic
02 110046 RK	PRD-9,600	Residential 9,600 sq. ft.	SFR-Basic
02 109378 RK	PRD-9,600	Residential 9,600 sq. ft.	SFR-Basic
02 110047 RK	PRD-9,600	Residential 9,600 sq. ft.	SFR-Basic
02 110048 RK	PRD-9,600	Residential 9,600 sq. ft.	SFR-Basic
02 109588 RK	PRD-9,600	Residential 9,600 sq. ft.	SFR-Basic
02 108684 RK	PRD-9,600	Residential 9,600 sq. ft.	Single Family Res-Combo
02 108070 RK	PRD-9,600	Residential 9,600 sq. ft.	Single Family Res-Combo
02 108069 RK	PRD-9,600	Residential 9,600 sq. ft.	Single Family Res-Combo
02 109448 RK	PRD-7,200	Residential 7,200 sq. ft.	SFR-Basic
02 109615 RK	PRD-7,200	Residential 7,200 sq. ft.	SFR-Basic
02 108423 RK	PRD-7,200	Residential 7,200 sq. ft.	SFR-Basic
02 109392 RK	PRD-7,200	Residential 7,200 sq. ft.	SFR-Basic
02 109385 RK	PRD-7,200	Residential 7,200 sq. ft.	SFR-Basic
02 108417 RK	PRD-7,200	Residential 7,200 sq. ft.	SFR-Basic
02 107174 MH	R-5	Rural-5 Acre	Double Wide
02 109673 RK	CITY	City	SFR-Basic
02 109732 RK	CITY	City	SFR-Basic
02 109675 RK	CITY	City	SFR-Basic
02 108820 RK	R-5	Rural-5 Acre	SFR-Basic
02 108819 RK	R-5	Rural-5 Acre	SFR-Basic
02 106301 RK	R-5	Rural-5 Acre	Single Family Res-Combo
02 108826 RK	R-5	Rural-5 Acre	SFR-Basic
02 109716 RK	R-5	Rural-5 Acre	SFR-Basic
02 109718 RK	R-5	Rural-5 Acre	SFR-Basic
02 109720 RK	R-5	Rural-5 Acre	SFR-Basic
02 109813 RK	R-5	Rural-5 Acre	SFR-Basic
02 109043 RK	PRD-9,600	Residential 9,600 sq. ft.	SFR-Basic
02 108878 RK	PRD-9,600	Residential 9,600 sq. ft.	SFR-Basic
02 108879 RK	PRD-9,600	Residential 9,600 sq. ft.	SFR-Basic
02 109044 RK	PRD-9,600	Residential 9,600 sq. ft.	SFR-Basic
02 109046 RK	PRD-9,600	Residential 9,600 sq. ft.	SFR-Basic
02 109219 RK	PRD-9,600	Residential 9,600 sq. ft.	SFR-Basic

Accessory Dwelling Units

Index # - File Name: 1.0022 - Single Family Dwellings Data\_Snohomish County.pdf

02 109218 RK	PRD-9,600	Residential 9,600 sq. ft.	SFR-Basic
02 109621 RK	PRD-9,600	Residential 9,600 sq. ft.	SFR-Basic
02 109623 RK	PRD-9,600	Residential 9,600 sq. ft.	SFR-Basic
02 109815 RK	R-5	Rural-5 Acre	SFR-Basic
02 109184 RK	R-5	Rural-5 Acre	Single Family Res-Combo
02 109183 RK	R-5	Rural-5 Acre	Single Family Res-Combo
02 109185 RK	R-5	Rural-5 Acre	Single Family Res-Combo
02 108675 RK	R-5	Rural-5 Acre	Single Family Res-Combo
02 108634 RK	R-5	Rural-5 Acre	Single Family Res-Combo
02 108674 RK	R-5	Rural-5 Acre	Single Family Res-Combo
02 108635 RK	R-5	Rural-5 Acre	Single Family Res-Combo
02 109846 RK	PRD-9,600	Residential 9,600 sq. ft.	SFR-Basic
02 109848 RK	PRD-9,600	Residential 9,600 sq. ft.	SFR-Basic
02 109849 RK	PRD-9,600	Residential 9,600 sq. ft.	SFR-Basic
02 109850 RK	PRD-9,600	Residential 9,600 sq. ft.	SFR-Basic
02 109851 RK	PRD-9,600	Residential 9,600 sq. ft.	SFR-Basic
02 109852 RK	PRD-9,600	Residential 9,600 sq. ft.	SFR-Basic
02 109816 RK	R-5	Rural-5 Acre	SFR-Basic
02 110056 RK	PRD-9,600	Residential 9,600 sq. ft.	SFR-Basic
02 110057 RK	PRD-9,600	Residential 9,600 sq. ft.	SFR-Basic
02 109620 RK	PRD-9,600	Residential 9,600 sq. ft.	SFR-Basic
02 110058 RK	PRD-9,600	Residential 9,600 sq. ft.	SFR-Basic
02 110059 RK	PRD-9,600	Residential 9,600 sq. ft.	SFR-Basic
02 110183 RK	PRD-9,600	Residential 9,600 sq. ft.	SFR-Basic
02 110329 RK	PRD-9,600	Residential 9,600 sq. ft.	SFR-Basic
02 110330 RK	PRD-9,600	Residential 9,600 sq. ft.	SFR-Basic
02 107994 RK	UC	Urban Center	Single Family Res-Combo
02 104280 RK	CITY	City	Single Family Res-Combo
02 110257 RK	PRD-9,600	Residential 9,600 sq. ft.	SFR-Basic
02 108595 RK	PRD-9,600	Residential 9,600 sq. ft.	Single Family Res-Combo
02 109458 RK	PRD-9,600	Residential 9,600 sq. ft.	SFR-Basic
02 108594 RK	PRD-9,600	Residential 9,600 sq. ft.	Single Family Res-Combo
02 109030 RK	PRD-9,600	Residential 9,600 sq. ft.	Single Family Res-Combo
02 108969 RK	PRD-9,600	Residential 9,600 sq. ft.	SFR-Basic
02 108951 RK	PRD-9,600	Residential 9,600 sq. ft.	SFR-Basic
02 108259 RK	R-8,400	Residential 8,400 sq. ft.	SFR-Basic
02 108862 RK	R-8,400	Residential 8,400 sq. ft.	SFR-Basic
02 108261 RK	R-8,400	Residential 8,400 sq. ft.	SFR-Basic
02 108268 RK	R-8,400	Residential 8,400 sq. ft.	SFR-Basic
02 108263 RK	R-8,400	Residential 8,400 sq. ft.	SFR-Basic
02 108264 RK	R-8,400	Residential 8,400 sq. ft.	SFR-Basic
02 108270 RK	R-8,400	Residential 8,400 sq. ft.	SFR-Basic
02 108266 RK	R-8,400	Residential 8,400 sq. ft.	SFR-Basic
02 108861 RK	R-8,400	Residential 8,400 sq. ft.	SFR-Basic
02 108271 RK	R-8,400	Residential 8,400 sq. ft.	SFR-Basic
02 108272 RK	R-8,400	Residential 8,400 sq. ft.	SFR-Basic
02 109756 RK	R-8,400	Residential 8,400 sq. ft.	SFR-Basic

Accessory Dwelling Units

Index # - File Name: 1.0022 - Single Family Dwellings Data\_Snohomish County.pdf

02 109591 RK	PRD-9,600	Residential 9,600 sq. ft.	SFR-Basic
02 110259 RK	PRD-9,600	Residential 9,600 sq. ft.	SFR-Basic
02 108829 RK	PRD-9,600	Residential 9,600 sq. ft.	Single Family Res-Combo
02 109725 RK	PRD-9,600	Residential 9,600 sq. ft.	SFR-Basic
02 109837 RK	PRD-9,600	Residential 9,600 sq. ft.	Single Family Res-Combo
02 109457 RK	PRD-9,600	Residential 9,600 sq. ft.	SFR-Basic
02 109727 RK	PRD-9,600	Residential 9,600 sq. ft.	SFR-Basic
02 109031 RK	PRD-9,600	Residential 9,600 sq. ft.	Single Family Res-Combo
02 109754 RK	R-8,400	Residential 8,400 sq. ft.	SFR-Basic
02 108447 RK	R-9,600	Residential 9,600 sq. ft.	Duplex-Basic
02 108267 RK	R-8,400	Residential 8,400 sq. ft.	SFR-Basic
02 108443 RK	R-9,600	Residential 9,600 sq. ft.	Duplex-Basic
02 108827 RK	R-5	Rural-5 Acre	Single Family Res-Combo
02 107312 RK	LDMR	Low Density Multiple Reside	Single Family Res-Combo
02 109023 RK	LDMR	Low Density Multiple Reside	SFR-Basic
02 109025 RK	LDMR	Low Density Multiple Reside	SFR-Basic
02 109024 RK	LDMR	Low Density Multiple Reside	SFR-Basic
02 109026 RK	LDMR	Low Density Multiple Reside	SFR-Basic
02 108947 RK	R-8,400	Residential 8,400 sq. ft.	Single Family Res-Combo
02 107561 RK	R-8,400	Residential 8,400 sq. ft.	Single Family Res-Combo
02 109826 RK	R-5	Rural-5 Acre	SFR-Basic
02 109823 RK	CITY	City	SFR-Basic
02 109824 RK	CITY	City	SFR-Basic
02 109822 RK	CITY	City	SFR-Basic
02 109819 RK	CITY	City	SFR-Basic
02 109825 RK	CITY	City	SFR-Basic
02 109637 MH	R-5	Rural-5 Acre	Triple Wide
02 109785 RK	CITY	City	SFR-Basic
02 109016 RK	CITY	City	Single Family Res-Combo
02 110791 RK	CITY	City	Duplex-Basic
02 110792 RK	CITY	City	Duplex-Basic
02 104669 RK	R-5	Rural-5 Acre	Single Family Res-Combo
02 107190 RK	R-5	Rural-5 Acre	Single Family Res-Combo
01 113052 RK	R-5	Rural-5 Acre	Single Family Res-Combo
00 102654 RK	R-5	Rural-5 Acre	Single Family Res-Combo
02 104118 RK	PRD SA-1	Suburban Agriculture-1 Acre	Duplex-Combo
02 107749 RK	R-5	Rural-5 Acre	Single Family Res-Combo
02 109136 RK	R-5	Rural-5 Acre	Single Family Res-Combo
02 104329 RK	R-9,600	Residential 9,600 sq. ft.	Single Family Res-Combo
02 104327 RK	R-9,600	Residential 9,600 sq. ft.	Single Family Res-Combo
01 113486 RK	R-9,600	Residential 9,600 sq. ft.	Single Family Res-Combo
02 100485 RK	R-9,600	Residential 9,600 sq. ft.	SFR-Basic
02 101585 RK	R-5	Rural-5 Acre	Single Family Res-Combo
00 103832 RK	CITY : R-5	City : Rural-5 Acre	Single Family Res-Combo
00 104120 000 01 RK	R-5	Rural-5 Acre	Single Family Res-Combo
01 100977 RK	R-5	Rural-5 Acre	Single Family Res-Combo
02 100248 RK	R-5	Rural-5 Acre	Single Family Res-Combo

Accessory Dwelling Units

Index # - File Name: 1.0022 - Single Family Dwellings Data\_Snohomish County.pdf

01 105674 RK	R-5	Rural-5 Acre	Single Family Res-Combo
01 112560 RK	R-5	Rural-5 Acre	Single Family Res-Combo
01 112985 RK	R-5	Rural-5 Acre	Single Family Res-Combo
01 110568 RK	R-5	Rural-5 Acre	Single Family Res-Combo
00 100492 RK	R-5	Rural-5 Acre	Single Family Res-Combo
02 105046 RK	R-5	Rural-5 Acre	Single Family Res-Combo
02 100544 RK	R-5	Rural-5 Acre	Single Family Res-Combo
02 105925 RK	R-5	Rural-5 Acre	Single Family Res-Combo
01 111371 RK	R-9,600	Residential 9,600 sq. ft.	SFR-Basic
02 101632 RK	PRD-9,600	Residential 9,600 sq. ft.	SFR-Basic
02 100160 RK	PRD-9,600	Residential 9,600 sq. ft.	SFR-Basic
02 102815 RK	PRD-9,600	Residential 9,600 sq. ft.	SFR-Basic
02 102817 RK	PRD-9,600	Residential 9,600 sq. ft.	SFR-Basic
02 103526 RK	PRD-9,600	Residential 9,600 sq. ft.	SFR-Basic
02 100490 RK	PRD-9,600	Residential 9,600 sq. ft.	SFR-Basic
01 105423 RK	R-5	Rural-5 Acre	Single Family Res-Combo
01 110925 RK	R-9,600(PRD)	Residential 9,600 sq. ft.	SFR-Basic
02 103107 RK	R-9,600(PRD)	Residential 9,600 sq. ft.	SFR-Basic
01 110927 RK	R-9,600(PRD)	Residential 9,600 sq. ft.	SFR-Basic
01 110932 RK	R-9,600(PRD)	Residential 9,600 sq. ft.	SFR-Basic
01 103319 MH	F	Forestry	Double Wide
01 113083 RK	R-9,600(PRD)	Residential 9,600 sq. ft.	SFR-Basic
01 110910 RK	R-9,600(PRD)	Residential 9,600 sq. ft.	SFR-Basic
01 110928 RK	R-9,600(PRD)	Residential 9,600 sq. ft.	SFR-Basic
02 101458 RK	R-9,600(PRD)	Residential 9,600 sq. ft.	Single Family Res-Combo
01 112806 RK	R-9,600(PRD)	Residential 9,600 sq. ft.	SFR-Basic
02 105514 RK	A-10	Agriculture-10 Acre	Single Family Res-Combo
01 111318 RK	R-5	Rural-5 Acre	Single Family Res-Combo
02 106197 RK	RD	Rural Diversification	Single Family Res-Combo
01 112932 RK	R-5	Rural-5 Acre	Single Family Res-Combo
01 112721 RK	R-5	Rural-5 Acre	Single Family Res-Combo
02 104115 RK	R-5	Rural-5 Acre	Single Family Res-Combo
02 108308 MH	F and R	Forestry and Recreation	Double Wide
01 112720 RK	R-5	Rural-5 Acre	Single Family Res-Combo
02 101627 RK	R-5	Rural-5 Acre	Single Family Res-Combo
02 104531 RK	R-5	Rural-5 Acre	Single Family Res-Combo
02 102336 RK	R-5	Rural-5 Acre	Single Family Res-Combo
02 103964 RK	R-5	Rural-5 Acre	Single Family Res-Combo
02 100435 RK	R-7,200	Residential 7,200 sq. ft.	SFR-Basic
02 100433 RK	R-7,200	Residential 7,200 sq. ft.	SFR-Basic
99 112750 000 01 RK	LDMR	Low Density Multiple Reside	Single Family Res-Combo
00 105911 000 01 RK	LDMR	Low Density Multiple Reside	SFR-Basic
02 106363 MH	R-5	Rural-5 Acre	Double Wide
00 105870 000 01 RK	LDMR	Low Density Multiple Reside	SFR-Basic
02 108376 RK	LDMR	Low Density Multiple Reside	SFR-Basic
02 109042 RK	R-5	Rural-5 Acre	Single Family Res-Combo
01 103389 RK	R-7,200	Residential 7,200 sq. ft.	Single Family Res-Combo



Accessory Dwelling Units

Index # - File Name: 1.0022 - Single Family Dwellings Data\_Snohomish County.pdf

99 116523 000 01 RK	R-5	Rural-5 Acre	Single Family Res-Combo
02 107386 RK	R-5	Rural-5 Acre	Single Family Res-Combo
02 102891 RK	R-5	Rural-5 Acre	Single Family Res-Combo
01 112904 RK	R-5	Rural-5 Acre	Single Family Res-Combo
02 105181 RK	R-9,600	Residential 9,600 sq. ft.	Single Family Res-Combo
02 104655 RK	RRT-10	Rural Resource Transition-10	Single Family Res-Combo
02 101701 RK	R-5	Rural-5 Acre	Single Family Res-Combo
02 106622 RK	R-5	Rural-5 Acre	Single Family Res-Combo
02 101596 RK	R-5	Rural-5 Acre	Single Family Res-Combo
02 102792 RK	RC	Rural Conservation	Single Family Res-Combo
02 104106 RK	R-5	Rural-5 Acre	Single Family Res-Combo
02 100761 MH	R-5	Rural-5 Acre	Triple Wide
02 100850 RK	R-5	Rural-5 Acre	Single Family Res-Combo
01 112548 RK	R-5	Rural-5 Acre	Single Family Res-Combo
02 108971 RK	R-5	Rural-5 Acre	SFR-Basic
01 110882 MH	R-5	Rural-5 Acre	Double Wide
01 113117 RK	F	Forestry	Single Family Res-Combo
02 104109 RK	R-5	Rural-5 Acre	SFR-Basic
02 104108 RK	R-5	Rural-5 Acre	SFR-Basic
01 105822 RK	R-5	Rural-5 Acre	Single Family Res-Combo
01 107447 RK	R-9,600	Residential 9,600 sq. ft.	Single Family Res-Combo
01 107449 RK	R-5	Rural-5 Acre	Single Family Res-Combo
00 107037 000 01 MH	R-5	Rural-5 Acre	Single Wide
02 102889 RK	R-5	Rural-5 Acre	SFR-Basic
01 111547 RK	R-5	Rural-5 Acre	SFR-Basic
01 111548 RK	R-5	Rural-5 Acre	SFR-Basic
02 103672 MH	R-5	Rural-5 Acre	Triple Wide
02 103124 RK	RRT-10	Rural Resource Transition-10	Single Family Res-Combo
02 104241 RK	R-9,600	Residential 9,600 sq. ft.	Single Family Res-Combo
02 101586 RK	R-9,600	Residential 9,600 sq. ft.	SFR-Basic
02 101587 RK	R-9,600	Residential 9,600 sq. ft.	Single Family Res-Combo
02 101590 RK	R-9,600	Residential 9,600 sq. ft.	Single Family Res-Combo
02 103945 RK	R-5	Rural-5 Acre	Single Family Res-Combo
01 111946 RK	R-9,600	Residential 9,600 sq. ft.	SFR-Basic
02 100405 RK	R-5	Rural-5 Acre	Single Family Res-Combo
02 103510 RK	MR	Multiple Residential	Single Family Res-Combo
02 102250 RK	PRD-9,600	Residential 9,600 sq. ft.	SFR-Basic
01 112395 MH	R-5	Rural-5 Acre	Double Wide
02 101054 RK	R-8,400	Residential 8,400 sq. ft.	Single Family Res-Combo
02 101840 RK	R-5	Rural-5 Acre	SFR-Basic
02 105372 RK	R-5	Rural-5 Acre	Single Family Res-Combo
02 105380 RK	R-5	Rural-5 Acre	SFR-Basic
02 106932 RK	RRT-10	Rural Resource Transition-10	Single Family Res-Combo
02 106935 RK	RRT-10	Rural Resource Transition-10	Single Family Res-Combo
02 109880 RK	RRT-10	Rural Resource Transition-10	Single Family Res-Combo
02 107409 RK	RRT-10	Rural Resource Transition-10	Single Family Res-Combo
02 107411 RK	RRT-10	Rural Resource Transition-10	Single Family Res-Combo

Accessory Dwelling Units

Index # - File Name: 1.0022 - Single Family Dwellings Data\_Snohomish County.pdf

01 112367 RK	PRD-7,200	Residential 7,200 sq. ft.	SFR-Basic
01 113577 RK	PRD-7,200	Residential 7,200 sq. ft.	SFR-Basic
01 113578 RK	PRD-7,200	Residential 7,200 sq. ft.	SFR-Basic
01 113580 RK	PRD-7,200	Residential 7,200 sq. ft.	SFR-Basic
01 113579 RK	PRD-7,200	Residential 7,200 sq. ft.	SFR-Basic
01 113581 RK	PRD-7,200	Residential 7,200 sq. ft.	SFR-Basic
02 100552 RK	PRD-7,200	Residential 7,200 sq. ft.	SFR-Basic
02 100553 RK	PRD-7,200	Residential 7,200 sq. ft.	SFR-Basic
02 101097 RK	PRD-7,200	Residential 7,200 sq. ft.	SFR-Basic
02 101098 RK	PRD-7,200	Residential 7,200 sq. ft.	SFR-Basic
02 102684 RK	PRD-7,200	Residential 7,200 sq. ft.	SFR-Basic
02 100056 RK	PRD-7,200	Residential 7,200 sq. ft.	SFR-Basic
01 103409 RK	PRD-7,200	Residential 7,200 sq. ft.	Single Family Res-Combo
02 100057 RK	PRD-7,200	Residential 7,200 sq. ft.	SFR-Basic
02 100059 RK	PRD-7,200	Residential 7,200 sq. ft.	SFR-Basic
02 100060 RK	PRD-7,200	Residential 7,200 sq. ft.	SFR-Basic
02 100135 RK	PRD-7,200	Residential 7,200 sq. ft.	SFR-Basic
02 102835 RK	PRD-7,200	Residential 7,200 sq. ft.	SFR-Basic
02 100133 RK	PRD-7,200	Residential 7,200 sq. ft.	SFR-Basic
02 102831 RK	PRD-7,200	Residential 7,200 sq. ft.	SFR-Basic
02 101580 RK	PRD-7,200	Residential 7,200 sq. ft.	SFR-Basic
02 102832 RK	PRD-7,200	Residential 7,200 sq. ft.	SFR-Basic
02 102829 RK	PRD-7,200	Residential 7,200 sq. ft.	SFR-Basic
02 102828 RK	PRD-7,200	Residential 7,200 sq. ft.	SFR-Basic
02 102833 RK	PRD-7,200	Residential 7,200 sq. ft.	SFR-Basic
02 101581 RK	PRD-7,200	Residential 7,200 sq. ft.	SFR-Basic
02 102278 RK	PRD-7,200	Residential 7,200 sq. ft.	SFR-Basic
02 107281 RK	R-5	Rural-5 Acre	Single Family Res-Combo
02 103117 RK	CITY	City	SFR-Basic
02 103116 RK	CITY	City	SFR-Basic
02 103118 RK	CITY	City	SFR-Basic
02 103127 RK	CITY	City	SFR-Basic
02 103130 RK	CITY	City	SFR-Basic
02 103134 RK	CITY	City	SFR-Basic
02 103119 RK	CITY	City	SFR-Basic
02 103129 RK	CITY	City	SFR-Basic
01 113667 RK	CITY	City	SFR-Basic
02 103135 RK	CITY	City	SFR-Basic
02 103131 RK	CITY	City	SFR-Basic
02 103820 RK	CITY	City	SFR-Basic
02 103133 RK	CITY	City	SFR-Basic
02 103126 RK	CITY	City	SFR-Basic
02 103132 RK	CITY	City	SFR-Basic
02 103123 RK	CITY	City	SFR-Basic
01 113671 RK	CITY	City	SFR-Basic
01 112390 RK	CITY	City	SFR-Basic
01 111335 MH	R-5	Rural-5 Acre	Single Wide

Accessory Dwelling Units

Index # - File Name: 1.0022 - Single Family Dwellings Data\_Snohomish County.pdf

02 100918 RK	R-5	Rural-5 Acre	Single Family Res-Combo
02 100301 RK	CITY	City	SFR-Basic
01 111675 RK	CITY	City	SFR-Basic
01 111676 RK	CITY	City	SFR-Basic
01 113669 RK	CITY	City	SFR-Basic
02 100316 RK	CITY	City	SFR-Basic
02 103128 RK	CITY	City	SFR-Basic
01 111674 RK	CITY	City	SFR-Basic
02 103120 RK	CITY	City	SFR-Basic
02 100314 RK	CITY	City	SFR-Basic
02 100315 RK	CITY	City	SFR-Basic
02 100302 RK	CITY	City	SFR-Basic
02 100303 RK	CITY	City	SFR-Basic
02 100304 RK	CITY	City	SFR-Basic
02 100305 RK	CITY	City	SFR-Basic
02 100306 RK	CITY	City	SFR-Basic
02 100307 RK	CITY	City	SFR-Basic
02 100308 RK	CITY	City	SFR-Basic
02 100309 RK	CITY	City	SFR-Basic
02 100310 RK	CITY	City	SFR-Basic
01 113668 RK	CITY	City	SFR-Basic
02 100311 RK	CITY	City	SFR-Basic
01 113670 RK	CITY	City	SFR-Basic
02 100312 RK	CITY	City	SFR-Basic
02 100317 RK	CITY	City	SFR-Basic
02 100318 RK	CITY	City	SFR-Basic
01 111672 RK	CITY	City	SFR-Basic
02 103237 RK	R-9,600	Residential 9,600 sq. ft.	SFR-Basic
01 112993 RK	R-9,600	Residential 9,600 sq. ft.	Single Family Res-Combo
02 105356 RK	R-9,600	Residential 9,600 sq. ft.	SFR-Basic
02 107433 RK	R-9,600	Residential 9,600 sq. ft.	SFR-Basic
02 105361 RK	R-9,600	Residential 9,600 sq. ft.	SFR-Basic
02 105816 RK	R-9,600	Residential 9,600 sq. ft.	SFR-Basic
02 105895 RK	R-9,600	Residential 9,600 sq. ft.	SFR-Basic
02 105362 RK	R-9,600	Residential 9,600 sq. ft.	SFR-Basic
02 101519 RK	R-9,600	Residential 9,600 sq. ft.	SFR-Basic
02 104333 RK	R-9,600	Residential 9,600 sq. ft.	SFR-Basic
02 100924 RK	R-9,600	Residential 9,600 sq. ft.	SFR-Basic
02 100128 RK	R-9,600	Residential 9,600 sq. ft.	Single Family Res-Combo
02 105842 RK	R-9,600	Residential 9,600 sq. ft.	Single Family Res-Combo
01 108060 RK	R-7,200	Residential 7,200 sq. ft.	Single Family Res-Combo
02 101607 RK	R-5	Rural-5 Acre	Single Family Res-Combo
02 105896 RK	R-9,600	Residential 9,600 sq. ft.	Single Family Res-Combo
02 105844 RK	R-9,600	Residential 9,600 sq. ft.	SFR-Basic
02 104294 RK	R-9,600	Residential 9,600 sq. ft.	SFR-Basic
02 109213 RK	R-9,600	Residential 9,600 sq. ft.	SFR-Basic
02 105944 RK	R-9,600	Residential 9,600 sq. ft.	SFR-Basic

Accessory Dwelling Units

Index # - File Name: 1.0022 - Single Family Dwellings Data\_Snohomish County.pdf

02 103236 RK	R-9,600	Residential 9,600 sq. ft.	SFR-Basic
01 111580 RK	R-7,200	Residential 7,200 sq. ft.	SFR-Basic
02 107701 RK	R-5	Rural-5 Acre	Single Family Res-Combo
02 101459 RK	R-5	Rural-5 Acre	Single Family Res-Combo
02 100228 RK	R-5	Rural-5 Acre	Single Family Res-Combo
02 104170 RK	R-5	Rural-5 Acre	Single Family Res-Combo
02 103285 RK	R-5	Rural-5 Acre	Single Family Res-Combo
02 106393 RK	R-5	Rural-5 Acre	Single Family Res-Combo
01 100376 RK	R-5	Rural-5 Acre	Single Family Res-Combo
02 103028 RK	R-5	Rural-5 Acre	Single Family Res-Combo
02 103864 RK	R-5	Rural-5 Acre	Single Family Res-Combo
01 110919 RK	R-9,600(PRD)	Residential 9,600 sq. ft.	SFR-Basic
02 100477 RK	R-9,600(PRD)	Residential 9,600 sq. ft.	SFR-Basic
01 110916 RK	R-9,600(PRD)	Residential 9,600 sq. ft.	SFR-Basic
01 110917 RK	R-9,600(PRD)	Residential 9,600 sq. ft.	SFR-Basic
01 110912 RK	R-9,600(PRD)	Residential 9,600 sq. ft.	SFR-Basic
02 102823 MH	R-5	Rural-5 Acre	Double Wide
01 112074 MH	RD	Rural Diversification	Double Wide
02 103500 RK	R-5	Rural-5 Acre	Single Family Res-Combo
02 108889 RK	R-5	Rural-5 Acre	Single Family Res-Combo
01 111696 RK	R-5	Rural-5 Acre	Single Family Res-Combo
01 111843 RK	PRD-9,600	Residential 9,600 sq. ft.	SFR-Basic
02 106351 RK	R-5	Rural-5 Acre	SFR-Basic
02 103474 RK	R-5	Rural-5 Acre	Single Family Res-Combo
02 103481 RK	R-5	Rural-5 Acre	SFR-Basic
01 106940 RK	R-5	Rural-5 Acre	SFR-Basic
02 107612 RK	R-5	Rural-5 Acre	Single Family Res-Combo
02 102179 RK	R-5	Rural-5 Acre	SFR-Basic
02 102175 RK	R-5	Rural-5 Acre	SFR-Basic
01 113395 RK	R-5	Rural-5 Acre	SFR-Basic
02 102180 RK	R-5	Rural-5 Acre	SFR-Basic
02 105661 RK	R-5	Rural-5 Acre	SFR-Basic
02 103482 RK	R-5	Rural-5 Acre	SFR-Basic
00 110228 RK	R-5	Rural-5 Acre	Single Family Res-Combo
02 102178 RK	R-5	Rural-5 Acre	SFR-Basic
00 106443 RK	R-5	Rural-5 Acre	Single Family Res-Combo
02 105662 RK	R-5	Rural-5 Acre	SFR-Basic
02 104410 RK	R-5	Rural-5 Acre	Single Family Res-Combo
01 108232 RK	R-5	Rural-5 Acre	SFR-Basic
02 102540 RK	R-5	Rural-5 Acre	Single Family Res-Combo
01 113493 RK	R-5	Rural-5 Acre	Single Family Res-Combo
00 108676 000 01 RK	R-5	Rural-5 Acre	Single Family Res-Combo
02 101170 RK	R-5	Rural-5 Acre	Single Family Res-Combo
02 108914 RK	R-5	Rural-5 Acre	Single Family Res-Combo
02 100426 RK	R-5	Rural-5 Acre	Single Family Res-Combo
02 104683 RK	R-5	Rural-5 Acre	Single Family Res-Combo
02 106296 RK	R-5	Rural-5 Acre	Single Family Res-Combo

Accessory Dwelling Units

Index # - File Name: 1.0022 - Single Family Dwellings Data\_Snohomish County.pdf

02 104448 RK	R-7,200	Residential 7,200 sq. ft.	SFR-Basic
02 100923 RK	R-7,200	Residential 7,200 sq. ft.	Single Family Res-Combo
02 105253 RK	R-7,200	Residential 7,200 sq. ft.	Single Family Res-Combo
02 106815 RK	R-7,200	Residential 7,200 sq. ft.	Single Family Res-Combo
02 104445 RK	R-7,200	Residential 7,200 sq. ft.	SFR-Basic
02 107438 RK	R-7,200	Residential 7,200 sq. ft.	Single Family Res-Combo
02 107437 RK	R-7,200	Residential 7,200 sq. ft.	Single Family Res-Combo
02 104369 RK	R-7,200	Residential 7,200 sq. ft.	SFR-Basic
02 104449 RK	R-7,200	Residential 7,200 sq. ft.	SFR-Basic
02 104359 RK	R-7,200	Residential 7,200 sq. ft.	Single Family Res-Combo
02 105257 RK	R-7,200	Residential 7,200 sq. ft.	Single Family Res-Combo
02 103407 RK	R-7,200	Residential 7,200 sq. ft.	Single Family Res-Combo
02 101717 RK	R-7,200	Residential 7,200 sq. ft.	Single Family Res-Combo
02 103989 RK	R-7,200	Residential 7,200 sq. ft.	Single Family Res-Combo
02 102873 RK	R-7,200	Residential 7,200 sq. ft.	Single Family Res-Combo
02 101712 RK	R-7,200	Residential 7,200 sq. ft.	SFR-Basic
02 101715 RK	R-7,200	Residential 7,200 sq. ft.	Single Family Res-Combo
02 104152 RK	R-7,200	Residential 7,200 sq. ft.	Single Family Res-Combo
02 103986 RK	R-7,200	Residential 7,200 sq. ft.	Single Family Res-Combo
02 104442 RK	R-7,200	Residential 7,200 sq. ft.	Single Family Res-Combo
02 106813 RK	R-7,200	Residential 7,200 sq. ft.	Single Family Res-Combo
02 101713 RK	R-7,200	Residential 7,200 sq. ft.	SFR-Basic
02 108174 RK	R-7,200	Residential 7,200 sq. ft.	Single Family Res-Combo
02 102704 RK	R-5	Rural-5 Acre	Single Family Res-Combo
01 111206 RK	R-5	Rural-5 Acre	Single Family Res-Combo
02 108957 RK	R-5	Rural-5 Acre	SFR-Basic
02 106911 RK	R-5	Rural-5 Acre	SFR-Basic
02 103194 RK	R-7,200	Residential 7,200 sq. ft.	Single Family Res-Combo
02 104158 RK	R-7,200	Residential 7,200 sq. ft.	Single Family Res-Combo
02 101739 RK	R-9,600	Residential 9,600 sq. ft.	SFR-Basic
02 103305 RK	R-9,600	Residential 9,600 sq. ft.	SFR-Basic
01 113633 RK	R-9,600	Residential 9,600 sq. ft.	SFR-Basic
02 100126 RK	R-9,600	Residential 9,600 sq. ft.	SFR-Basic
02 104154 RK	R-7,200	Residential 7,200 sq. ft.	Single Family Res-Combo
02 104919 RK	PRD-9,600	Residential 9,600 sq. ft.	Single Family Res-Combo
02 100885 RK	R-5	Rural-5 Acre	Single Family Res-Combo
01 105972 MH	R-5	Rural-5 Acre	Double Wide
01 111508 RK	R-5	Rural-5 Acre	Single Family Res-Combo
02 106783 RK	R-5	Rural-5 Acre	SFR-Basic
02 103659 RK	R-5	Rural-5 Acre	SFR-Basic
01 111247 RK	R-5	Rural-5 Acre	Single Family Res-Combo
02 100779 RK	R-5	Rural-5 Acre	Single Family Res-Combo
02 102062 RK	R-5	Rural-5 Acre	SFR-Basic
01 108274 RK	R-5	Rural-5 Acre	Single Family Res-Combo
02 108678 MH	LDMR	Low Density Multiple Reside	Double Wide
01 112583 RK	PRD-7,200	Residential 7,200 sq. ft.	SFR-Basic
01 112591 RK	PRD-7,200	Residential 7,200 sq. ft.	Single Family Res-Combo

Accessory Dwelling Units

Index # - File Name: 1.0022 - Single Family Dwellings Data\_Snohomish County.pdf

01 112715 RK	R-5	Rural-5 Acre	Single Family Res-Combo
01 112723 RK	R-5	Rural-5 Acre	Single Family Res-Combo
02 105803 RK	PRD-9,600	Residential 9,600 sq. ft.	SFR-Basic
02 105808 RK	PRD-9,600	Residential 9,600 sq. ft.	SFR-Basic
02 105800 RK	PRD-9,600	Residential 9,600 sq. ft.	SFR-Basic
02 100409 RK	PRD-9,600	Residential 9,600 sq. ft.	SFR-Basic
02 100411 RK	PRD-9,600	Residential 9,600 sq. ft.	SFR-Basic
02 100410 RK	PRD-9,600	Residential 9,600 sq. ft.	SFR-Basic
02 100408 RK	PRD-9,600	Residential 9,600 sq. ft.	SFR-Basic
02 100825 RK	PRD-9,600	Residential 9,600 sq. ft.	SFR-Basic
01 112744 RK	PRD-9,600	Residential 9,600 sq. ft.	SFR-Basic
02 100826 RK	PRD-9,600	Residential 9,600 sq. ft.	SFR-Basic
02 100827 RK	PRD-9,600	Residential 9,600 sq. ft.	SFR-Basic
02 101447 RK	PRD-9,600	Residential 9,600 sq. ft.	SFR-Basic
02 101446 RK	PRD-9,600	Residential 9,600 sq. ft.	SFR-Basic
02 101445 RK	PRD-9,600	Residential 9,600 sq. ft.	SFR-Basic
02 101444 RK	PRD-9,600	Residential 9,600 sq. ft.	SFR-Basic
02 101443 RK	PRD-9,600	Residential 9,600 sq. ft.	SFR-Basic
02 101851 RK	PRD-9,600	Residential 9,600 sq. ft.	SFR-Basic
02 101850 RK	PRD-9,600	Residential 9,600 sq. ft.	SFR-Basic
02 101848 RK	PRD-9,600	Residential 9,600 sq. ft.	SFR-Basic
02 101847 RK	PRD-9,600	Residential 9,600 sq. ft.	SFR-Basic
02 101846 RK	PRD-9,600	Residential 9,600 sq. ft.	SFR-Basic
02 101845 RK	PRD-9,600	Residential 9,600 sq. ft.	SFR-Basic
02 100994 RK	PRD-9,600	Residential 9,600 sq. ft.	SFR-Basic
02 100993 RK	PRD-9,600	Residential 9,600 sq. ft.	SFR-Basic
02 100139 RK	PRD-9,600	Residential 9,600 sq. ft.	SFR-Basic
02 100138 RK	PRD-9,600	Residential 9,600 sq. ft.	SFR-Basic
01 111801 RK	PRD-9,600	Residential 9,600 sq. ft.	Single Family Res-Combo
02 103106 RK	PRD-9,600	Residential 9,600 sq. ft.	SFR-Basic
02 103292 RK	PRD-9,600	Residential 9,600 sq. ft.	SFR-Basic
02 103905 RK	PRD-9,600	Residential 9,600 sq. ft.	SFR-Basic
02 103906 RK	PRD-9,600	Residential 9,600 sq. ft.	SFR-Basic
02 104455 RK	PRD-9,600	Residential 9,600 sq. ft.	SFR-Basic
02 104456 RK	PRD-9,600	Residential 9,600 sq. ft.	SFR-Basic
02 104457 RK	PRD-9,600	Residential 9,600 sq. ft.	SFR-Basic
02 104458 RK	PRD-9,600	Residential 9,600 sq. ft.	SFR-Basic
02 104719 RK	PRD-9,600	Residential 9,600 sq. ft.	SFR-Basic
02 104718 RK	PRD-9,600	Residential 9,600 sq. ft.	SFR-Basic
02 105806 RK	PRD-9,600	Residential 9,600 sq. ft.	SFR-Basic
02 105804 RK	PRD-9,600	Residential 9,600 sq. ft.	SFR-Basic
02 105809 RK	PRD-9,600	Residential 9,600 sq. ft.	SFR-Basic
02 105805 RK	PRD-9,600	Residential 9,600 sq. ft.	SFR-Basic
02 105807 RK	PRD-9,600	Residential 9,600 sq. ft.	SFR-Basic
02 105801 RK	PRD-9,600	Residential 9,600 sq. ft.	SFR-Basic
02 105810 RK	PRD-9,600	Residential 9,600 sq. ft.	SFR-Basic
02 105802 RK	PRD-9,600	Residential 9,600 sq. ft.	SFR-Basic

Accessory Dwelling Units

Index # - File Name: 1.0022 - Single Family Dwellings Data\_Snohomish County.pdf

02 100828 RK	PRD-9,600	Residential 9,600 sq. ft.	SFR-Basic
02 100829 RK	PRD-9,600	Residential 9,600 sq. ft.	SFR-Basic
01 112793 RK	PRD-9,600	Residential 9,600 sq. ft.	Single Family Res-Combo
02 105166 RK	PRD-9,600	Residential 9,600 sq. ft.	SFR-Basic
02 101613 RK	PRD-9,600	Residential 9,600 sq. ft.	SFR-Basic
01 112796 RK	PRD-9,600	Residential 9,600 sq. ft.	Single Family Res-Combo
01 112799 RK	PRD-9,600	Residential 9,600 sq. ft.	Single Family Res-Combo
02 105167 RK	PRD-9,600	Residential 9,600 sq. ft.	SFR-Basic
02 103953 RK	PRD-9,600	Residential 9,600 sq. ft.	SFR-Basic
02 105168 RK	PRD-9,600	Residential 9,600 sq. ft.	SFR-Basic
02 105169 RK	PRD-9,600	Residential 9,600 sq. ft.	SFR-Basic
02 105170 RK	PRD-9,600	Residential 9,600 sq. ft.	SFR-Basic
02 105171 RK	PRD-9,600	Residential 9,600 sq. ft.	SFR-Basic
02 103954 RK	PRD-9,600	Residential 9,600 sq. ft.	Single Family Res-Combo
02 105172 RK	PRD-9,600	Residential 9,600 sq. ft.	SFR-Basic
02 105173 RK	PRD-9,600	Residential 9,600 sq. ft.	SFR-Basic
02 105174 RK	PRD-9,600	Residential 9,600 sq. ft.	SFR-Basic
02 110428 RK	PRD-9,600	Residential 9,600 sq. ft.	SFR-Basic
02 105176 RK	PRD-9,600	Residential 9,600 sq. ft.	SFR-Basic
02 100276 RK	PRD-9,600	Residential 9,600 sq. ft.	SFR-Basic
02 100278 RK	PRD-9,600	Residential 9,600 sq. ft.	SFR-Basic
02 100277 RK	PRD-9,600	Residential 9,600 sq. ft.	SFR-Basic
02 103723 RK	PRD-9,600	Residential 9,600 sq. ft.	SFR-Basic
02 103722 RK	PRD-9,600	Residential 9,600 sq. ft.	SFR-Basic
02 106742 RK	PRD-9,600	Residential 9,600 sq. ft.	SFR-Basic
02 106745 RK	PRD-9,600	Residential 9,600 sq. ft.	SFR-Basic
02 106746 RK	PRD-9,600	Residential 9,600 sq. ft.	SFR-Basic
02 106744 RK	PRD-9,600	Residential 9,600 sq. ft.	SFR-Basic
02 106747 RK	PRD-9,600	Residential 9,600 sq. ft.	SFR-Basic
02 100417 RK	PRD-9,600	Residential 9,600 sq. ft.	SFR-Basic
02 100419 RK	PRD-9,600	Residential 9,600 sq. ft.	SFR-Basic
02 105634 RK	PRD-9,600	Residential 9,600 sq. ft.	SFR-Basic
02 100913 RK	PRD-9,600	Residential 9,600 sq. ft.	Single Family Res-Combo
02 100911 RK	PRD-9,600	Residential 9,600 sq. ft.	Single Family Res-Combo
02 104542 RK	PRD-9,600	Residential 9,600 sq. ft.	SFR-Basic
02 104257 RK	PRD-9,600	Residential 9,600 sq. ft.	SFR-Basic
02 102819 RK	PRD-9,600	Residential 9,600 sq. ft.	SFR-Basic
02 102818 RK	PRD-9,600	Residential 9,600 sq. ft.	SFR-Basic
02 104540 RK	PRD-9,600	Residential 9,600 sq. ft.	SFR-Basic
02 101462 RK	PRD-9,600	Residential 9,600 sq. ft.	SFR-Basic
02 101611 RK	PRD-9,600	Residential 9,600 sq. ft.	SFR-Basic
02 104283 RK	PRD-9,600	Residential 9,600 sq. ft.	SFR-Basic
02 103537 RK	PRD-9,600	Residential 9,600 sq. ft.	SFR-Basic
02 105177 RK	PRD-9,600	Residential 9,600 sq. ft.	SFR-Basic
02 105178 RK	PRD-9,600	Residential 9,600 sq. ft.	SFR-Basic
02 105179 RK	PRD-9,600	Residential 9,600 sq. ft.	SFR-Basic
02 104256 RK	PRD-9,600	Residential 9,600 sq. ft.	SFR-Basic

Accessory Dwelling Units

Index # - File Name: 1.0022 - Single Family Dwellings Data\_Snohomish County.pdf

02 105180 RK	PRD-9,600	Residential 9,600 sq. ft.	SFR-Basic
02 102522 RK	PRD-9,600	Residential 9,600 sq. ft.	SFR-Basic
02 102525 RK	PRD-9,600	Residential 9,600 sq. ft.	SFR-Basic
02 105182 RK	PRD-9,600	Residential 9,600 sq. ft.	SFR-Basic
02 101461 RK	PRD-9,600	Residential 9,600 sq. ft.	SFR-Basic
02 101612 RK	PRD-9,600	Residential 9,600 sq. ft.	SFR-Basic
02 101460 RK	PRD-9,600	Residential 9,600 sq. ft.	SFR-Basic
02 100917 RK	PRD-9,600	Residential 9,600 sq. ft.	SFR-Basic
02 100534 RK	PRD-9,600	Residential 9,600 sq. ft.	SFR-Basic
02 100340 RK	PRD-9,600	Residential 9,600 sq. ft.	SFR-Basic
02 100420 RK	PRD-9,600	Residential 9,600 sq. ft.	SFR-Basic
01 112802 RK	PRD-9,600	Residential 9,600 sq. ft.	Single Family Res-Combo
02 100415 RK	PRD-9,600	Residential 9,600 sq. ft.	SFR-Basic
01 112801 RK	PRD-9,600	Residential 9,600 sq. ft.	Single Family Res-Combo
02 100341 RK	PRD-9,600	Residential 9,600 sq. ft.	SFR-Basic
02 100916 RK	PRD-9,600	Residential 9,600 sq. ft.	SFR-Basic
02 101463 RK	PRD-9,600	Residential 9,600 sq. ft.	SFR-Basic
01 112803 RK	PRD-9,600	Residential 9,600 sq. ft.	Single Family Res-Combo
02 102826 RK	PRD-9,600	Residential 9,600 sq. ft.	SFR-Basic
02 102762 RK	PRD-9,600	Residential 9,600 sq. ft.	SFR-Basic
02 105636 RK	PRD-9,600	Residential 9,600 sq. ft.	SFR-Basic
02 100915 RK	PRD-9,600	Residential 9,600 sq. ft.	Single Family Res-Combo
02 105183 RK	PRD-9,600	Residential 9,600 sq. ft.	SFR-Basic
02 105184 RK	PRD-9,600	Residential 9,600 sq. ft.	SFR-Basic
02 105185 RK	PRD-9,600	Residential 9,600 sq. ft.	SFR-Basic
02 100275 RK	PRD-9,600	Residential 9,600 sq. ft.	SFR-Basic
02 100113 RK	R-5	Rural-5 Acre	Single Family Res-Combo
02 103197 RK	R-5	Rural-5 Acre	Single Family Res-Combo
02 103195 RK	R-5	Rural-5 Acre	Single Family Res-Combo
02 101568 RK	R-5	Rural-5 Acre	Single Family Res-Combo
02 100115 RK	R-5	Rural-5 Acre	Single Family Res-Combo
02 100823 RK	R-5	Rural-5 Acre	SFR-Basic
02 100757 RK	R-5	Rural-5 Acre	SFR-Basic
02 100760 RK	R-5	Rural-5 Acre	SFR-Basic
02 103281 RK	R-5	Rural-5 Acre	SFR-Basic
01 113749 RK	R-5	Rural-5 Acre	Single Family Res-Combo
01 113632 RK	R-5	Rural-5 Acre	SFR-Basic
01 113748 RK	R-5	Rural-5 Acre	SFR-Basic
01 113564 RK	R-5	Rural-5 Acre	SFR-Basic
01 113565 RK	R-5	Rural-5 Acre	SFR-Basic
01 112580 RK	PRD-7,200	Residential 7,200 sq. ft.	Single Family Res-Combo
02 109091 RK	R-5	Rural-5 Acre	SFR-Basic
02 105921 RK	PRD-9,600	Residential 9,600 sq. ft.	SFR-Basic
01 112309 RK	RRT-10	Rural Resource Transition-10	Single Family Res-Combo
01 112577 RK	PRD-7,200	Residential 7,200 sq. ft.	Single Family Res-Combo
02 102875 RK	PRD-9,600	Residential 9,600 sq. ft.	SFR-Basic
01 113116 RK	PRD-9,600	Residential 9,600 sq. ft.	Single Family Res-Combo



Accessory Dwelling Units

Index # - File Name: 1.0022 - Single Family Dwellings Data\_Snohomish County.pdf

02 101556 RK	PRD-9,600	Residential 9,600 sq. ft.	SFR-Basic
02 109520 RK	R-5	Rural-5 Acre	Single Family Res-Combo
01 112450 RK	R-5	Rural-5 Acre	Single Family Res-Combo
01 112587 RK	PRD-7,200	Residential 7,200 sq. ft.	SFR-Basic
01 112581 RK	PRD-7,200	Residential 7,200 sq. ft.	SFR-Basic
01 112590 RK	PRD-7,200	Residential 7,200 sq. ft.	SFR-Basic
01 112595 RK	PRD-7,200	Residential 7,200 sq. ft.	Single Family Res-Combo
01 112582 RK	PRD-7,200	Residential 7,200 sq. ft.	SFR-Basic
01 112579 RK	PRD-7,200	Residential 7,200 sq. ft.	SFR-Basic
01 112589 RK	PRD-7,200	Residential 7,200 sq. ft.	SFR-Basic
01 112584 RK	PRD-7,200	Residential 7,200 sq. ft.	SFR-Basic
01 113520 RK	PRD-7,200	Residential 7,200 sq. ft.	Single Family Res-Combo
01 113521 RK	PRD-7,200	Residential 7,200 sq. ft.	Single Family Res-Combo
02 100082 RK	PRD-7,200	Residential 7,200 sq. ft.	Single Family Res-Combo
01 113508 RK	PRD-7,200	Residential 7,200 sq. ft.	SFR-Basic
02 103967 RK	PRD-7,200	Residential 7,200 sq. ft.	Single Family Res-Combo
01 113522 RK	PRD-7,200	Residential 7,200 sq. ft.	Single Family Res-Combo
01 112594 RK	PRD-7,200	Residential 7,200 sq. ft.	Single Family Res-Combo
01 112586 RK	PRD-7,200	Residential 7,200 sq. ft.	SFR-Basic
01 113510 RK	PRD-7,200	Residential 7,200 sq. ft.	SFR-Basic
01 113511 RK	PRD-7,200	Residential 7,200 sq. ft.	SFR-Basic
01 113512 RK	PRD-7,200	Residential 7,200 sq. ft.	SFR-Basic
02 100081 RK	PRD-7,200	Residential 7,200 sq. ft.	SFR-Basic
02 103816 RK	PRD-7,200	Residential 7,200 sq. ft.	SFR-Basic
02 103814 RK	PRD-7,200	Residential 7,200 sq. ft.	Single Family Res-Combo
02 103966 RK	PRD-7,200	Residential 7,200 sq. ft.	Single Family Res-Combo
01 113513 RK	PRD-7,200	Residential 7,200 sq. ft.	SFR-Basic
01 113515 RK	PRD-7,200	Residential 7,200 sq. ft.	SFR-Basic
01 113519 RK	PRD-7,200	Residential 7,200 sq. ft.	SFR-Basic
02 100517 RK	PRD-9,600	Residential 9,600 sq. ft.	Single Family Res-Combo
02 105981 RK	PRD-9,600	Residential 9,600 sq. ft.	SFR-Basic
02 105924 RK	PRD-9,600	Residential 9,600 sq. ft.	SFR-Basic
02 101555 RK	PRD-9,600	Residential 9,600 sq. ft.	SFR-Basic
02 101430 RK	PRD-9,600	Residential 9,600 sq. ft.	SFR-Basic
02 100401 RK	PRD-9,600	Residential 9,600 sq. ft.	Single Family Res-Combo
02 100399 RK	PRD-9,600	Residential 9,600 sq. ft.	SFR-Basic
02 108140 RK	PRD-9,600	Residential 9,600 sq. ft.	SFR-Basic
02 105919 RK	PRD-9,600	Residential 9,600 sq. ft.	SFR-Basic
02 100398 RK	PRD-9,600	Residential 9,600 sq. ft.	SFR-Basic
02 101557 RK	PRD-9,600	Residential 9,600 sq. ft.	SFR-Basic
02 105914 RK	PRD-9,600	Residential 9,600 sq. ft.	SFR-Basic
02 105552 RK	PRD-9,600	Residential 9,600 sq. ft.	SFR-Basic
02 105557 RK	PRD-9,600	Residential 9,600 sq. ft.	SFR-Basic
01 110827 RK	PRD-9,600	Residential 9,600 sq. ft.	Single Family Res-Combo
01 110821 RK	PRD-9,600	Residential 9,600 sq. ft.	Single Family Res-Combo
02 103884 RK	CITY	City	SFR-Basic
02 103885 RK	CITY	City	SFR-Basic

Accessory Dwelling Units

Index # - File Name: 1.0022 - Single Family Dwellings Data\_Snohomish County.pdf

02 104797 RK	CITY	City	SFR-Basic
02 103886 RK	CITY	City	SFR-Basic
02 103887 RK	CITY	City	SFR-Basic
01 113536 RK	CITY	City	SFR-Basic
01 113733 RK	CITY	City	SFR-Basic
01 113732 RK	CITY	City	SFR-Basic
02 104528 RK	CITY	City	SFR-Basic
02 101916 RK	CITY	City	SFR-Basic
02 104518 RK	CITY	City	SFR-Basic
02 104520 RK	CITY	City	SFR-Basic
02 104521 RK	CITY	City	SFR-Basic
02 104522 RK	CITY	City	SFR-Basic
02 104530 RK	CITY	City	SFR-Basic
02 104523 RK	CITY	City	SFR-Basic
02 101911 RK	CITY	City	SFR-Basic
02 103413 RK	CITY	City	SFR-Basic
02 104524 RK	CITY	City	SFR-Basic
02 104525 RK	CITY	City	SFR-Basic
02 104526 RK	CITY	City	SFR-Basic
02 104527 RK	CITY	City	SFR-Basic
02 104176 RK	CITY	City	SFR-Basic
02 104177 RK	CITY	City	SFR-Basic
02 104178 RK	CITY	City	SFR-Basic
02 104179 RK	CITY	City	SFR-Basic
02 104181 RK	CITY	City	SFR-Basic
02 104182 RK	CITY	City	SFR-Basic
02 104183 RK	CITY	City	SFR-Basic
02 104798 RK	CITY	City	SFR-Basic
02 104513 RK	CITY	City	SFR-Basic
02 104515 RK	CITY	City	SFR-Basic
02 104516 RK	CITY	City	SFR-Basic
02 104517 RK	CITY	City	SFR-Basic
02 104180 RK	CITY	City	SFR-Basic
02 104514 RK	CITY	City	SFR-Basic
02 103879 RK	CITY	City	SFR-Basic
02 103882 RK	CITY	City	SFR-Basic
02 103888 RK	CITY	City	SFR-Basic
02 102588 RK	CITY	City	Single Family Res-Combo
02 100102 RK	CITY	City	SFR-Basic
02 101403 RK	CITY	City	SFR-Basic
02 100811 RK	CITY	City	SFR-Basic
02 100812 RK	CITY	City	SFR-Basic
02 100813 RK	CITY	City	SFR-Basic
02 100814 RK	CITY	City	SFR-Basic
02 101402 RK	CITY	City	SFR-Basic
02 102586 RK	CITY	City	Single Family Res-Combo
02 101401 RK	CITY	City	SFR-Basic

Accessory Dwelling Units

Index # - File Name: 1.0022 - Single Family Dwellings Data\_Snohomish County.pdf

02 101400 RK	CITY	City	SFR-Basic
02 101399 RK	CITY	City	SFR-Basic
02 103880 RK	CITY	City	SFR-Basic
02 103881 RK	CITY	City	SFR-Basic
02 104175 RK	CITY	City	SFR-Basic
01 113724 RK	CITY	City	SFR-Basic
01 112837 RK	CITY	City	SFR-Basic
01 113725 RK	CITY	City	SFR-Basic
01 112838 RK	CITY	City	SFR-Basic
01 113726 RK	CITY	City	SFR-Basic
01 112839 RK	CITY	City	SFR-Basic
01 113727 RK	CITY	City	SFR-Basic
01 112840 RK	CITY	City	SFR-Basic
01 113728 RK	CITY	City	SFR-Basic
01 112841 RK	CITY	City	SFR-Basic
01 113730 RK	CITY	City	SFR-Basic
01 112842 RK	CITY	City	SFR-Basic
01 113731 RK	CITY	City	SFR-Basic
02 100098 RK	CITY	City	SFR-Basic
02 100099 RK	CITY	City	SFR-Basic
02 100100 RK	CITY	City	SFR-Basic
02 100101 RK	CITY	City	SFR-Basic
02 101760 RK	R-5	Rural-5 Acre	Single Family Res-Combo
02 106180 RK	R-5	Rural-5 Acre	Single Family Res-Combo
02 107522 RK	R-5	Rural-5 Acre	Single Family Res-Combo
01 112032 RK	R-5	Rural-5 Acre	Single Family Res-Combo
02 103883 RK	CITY	City	SFR-Basic
02 101422 RK	R-5	Rural-5 Acre	Single Family Res-Combo
02 105826 RK	R-5	Rural-5 Acre	Single Family Res-Combo
02 103232 RK	R-5	Rural-5 Acre	Single Family Res-Combo
02 103764 RK	R-5	Rural-5 Acre	Single Family Res-Combo
02 103673 RK	F : R-5	Forestry : Rural-5 Acre	Single Family Res-Combo
01 111385 RK	R-5	Rural-5 Acre	SFR-Basic
02 102575 RK	R-5	Rural-5 Acre	Single Family Res-Combo
01 112065 RK	R-5	Rural-5 Acre	Single Family Res-Combo
01 111635 RK	R-5	Rural-5 Acre	Single Family Res-Combo
02 101408 RK	PRD-7,200	Residential 7,200 sq. ft.	SFR-Basic
01 113647 RK	CITY	City	SFR-Basic
02 105461 RK	CITY	City	SFR-Basic
02 105190 RK	CITY	City	SFR-Basic
02 105497 RK	CITY	City	SFR-Basic
02 105495 RK	CITY	City	SFR-Basic
02 105475 RK	CITY	City	SFR-Basic
02 105460 RK	CITY	City	SFR-Basic
02 104230 RK	CITY	City	SFR-Basic
02 102302 RK	CITY	City	SFR-Basic
02 104010 RK	CITY	City	SFR-Basic

Accessory Dwelling Units

Index # - File Name: 1.0022 - Single Family Dwellings Data\_Snohomish County.pdf

02 104225 RK	CITY	City	SFR-Basic
02 105494 RK	CITY	City	SFR-Basic
02 105473 RK	CITY	City	SFR-Basic
02 101574 RK	CITY	City	SFR-Basic
02 105493 RK	CITY	City	SFR-Basic
02 105492 RK	CITY	City	SFR-Basic
02 105491 RK	CITY	City	SFR-Basic
02 100527 RK	CITY	City	SFR-Basic
02 105490 RK	CITY	City	SFR-Basic
02 105459 RK	CITY	City	SFR-Basic
02 102303 RK	CITY	City	SFR-Basic
02 102871 RK	CITY	City	SFR-Basic
02 104814 RK	CITY	City	SFR-Basic
02 102492 RK	CITY	City	SFR-Basic
02 104812 RK	CITY	City	SFR-Basic
01 113649 RK	CITY	City	SFR-Basic
01 113648 RK	CITY	City	SFR-Basic
01 112369 RK	PRD-7,200	Residential 7,200 sq. ft.	Single Family Res-Combo
02 100062 RK	PRD-7,200	Residential 7,200 sq. ft.	Single Family Res-Combo
02 102654 RK	PRD-7,200	Residential 7,200 sq. ft.	SFR-Basic
02 102655 RK	PRD-7,200	Residential 7,200 sq. ft.	SFR-Basic
02 105462 RK	CITY	City	SFR-Basic
02 105463 RK	CITY	City	SFR-Basic
02 101875 RK	PRD-7,200	Residential 7,200 sq. ft.	SFR-Basic
01 112368 RK	PRD-7,200	Residential 7,200 sq. ft.	Single Family Res-Combo
01 112370 RK	PRD-7,200	Residential 7,200 sq. ft.	Single Family Res-Combo
02 102656 RK	PRD-7,200	Residential 7,200 sq. ft.	SFR-Basic
02 102836 RK	CITY	City	SFR-Basic
02 104015 RK	CITY	City	SFR-Basic
02 105485 RK	CITY	City	SFR-Basic
02 104684 RK	CITY	City	SFR-Basic
02 102830 RK	CITY	City	SFR-Basic
02 101857 RK	CITY	City	SFR-Basic
02 103366 RK	CITY	City	SFR-Basic
02 103365 RK	CITY	City	SFR-Basic
02 102114 RK	CITY	City	SFR-Basic
02 105480 RK	CITY	City	SFR-Basic
02 105467 RK	CITY	City	SFR-Basic
02 105454 RK	CITY	City	SFR-Basic
02 105479 RK	CITY	City	SFR-Basic
02 105466 RK	CITY	City	SFR-Basic
02 105478 RK	CITY	City	SFR-Basic
02 105464 RK	CITY	City	SFR-Basic
02 101457 RK	CITY	City	SFR-Basic
02 105486 RK	CITY	City	SFR-Basic
02 105470 RK	CITY	City	SFR-Basic
02 105487 RK	CITY	City	SFR-Basic

Accessory Dwelling Units

Index # - File Name: 1.0022 - Single Family Dwellings Data\_Snohomish County.pdf

02 105471 RK	CITY	City	SFR-Basic
02 105488 RK	CITY	City	SFR-Basic
02 105458 RK	CITY	City	SFR-Basic
02 105472 RK	CITY	City	SFR-Basic
02 105489 RK	CITY	City	SFR-Basic
02 100525 RK	CITY	City	SFR-Basic
02 102490 RK	CITY	City	SFR-Basic
02 100526 RK	CITY	City	SFR-Basic
02 105499 RK	CITY	City	SFR-Basic
02 105477 RK	CITY	City	SFR-Basic
02 104565 RK	CITY	City	SFR-Basic
01 112980 RK	CITY	City	SFR-Basic
02 103852 RK	CITY	City	SFR-Basic
02 101096 RK	CITY	City	SFR-Basic
02 101173 RK	CITY	City	SFR-Basic
02 105481 RK	CITY	City	SFR-Basic
02 105455 RK	CITY	City	SFR-Basic
02 105469 RK	CITY	City	SFR-Basic
02 103654 RK	CITY	City	SFR-Basic
02 104682 RK	CITY	City	SFR-Basic
02 103369 RK	CITY	City	SFR-Basic
02 102113 RK	CITY	City	SFR-Basic
02 102874 RK	CITY	City	SFR-Basic
02 105484 RK	CITY	City	SFR-Basic
02 105457 RK	CITY	City	SFR-Basic
02 105482 RK	CITY	City	SFR-Basic
02 101456 RK	CITY	City	SFR-Basic
02 101099 RK	CITY	City	SFR-Basic
02 105191 RK	CITY	City	SFR-Basic
02 103809 RK	CITY	City	SFR-Basic
02 103853 RK	CITY	City	SFR-Basic
02 105502 RK	CITY	City	SFR-Basic
02 105500 RK	CITY	City	SFR-Basic
02 105505 RK	CITY	City	SFR-Basic
02 105504 RK	CITY	City	SFR-Basic
01 112979 RK	CITY	City	SFR-Basic
02 103652 RK	CITY	City	SFR-Basic
02 103808 RK	CITY	City	SFR-Basic
02 100539 RK	PRD-7,200	Residential 7,200 sq. ft.	SFR-Basic
02 101197 RK	PRD-7,200	Residential 7,200 sq. ft.	SFR-Basic
02 101198 RK	PRD-7,200	Residential 7,200 sq. ft.	SFR-Basic
02 102086 RK	PRD-7,200	Residential 7,200 sq. ft.	SFR-Basic
02 102089 RK	PRD-7,200	Residential 7,200 sq. ft.	SFR-Basic
02 102088 RK	PRD-7,200	Residential 7,200 sq. ft.	SFR-Basic
02 101472 RK	PRD-7,200	Residential 7,200 sq. ft.	SFR-Basic
02 102070 RK	PRD-7,200	Residential 7,200 sq. ft.	SFR-Basic
02 100389 RK	PRD-7,200	Residential 7,200 sq. ft.	SFR-Basic

Accessory Dwelling Units

Index # - File Name: 1.0022 - Single Family Dwellings Data\_Snohomish County.pdf

01 113739 RK	PRD-7,200	Residential 7,200 sq. ft.	SFR-Basic
01 113740 RK	PRD-7,200	Residential 7,200 sq. ft.	SFR-Basic
01 113473 RK	PRD-7,200	Residential 7,200 sq. ft.	SFR-Basic
01 113475 RK	PRD-7,200	Residential 7,200 sq. ft.	SFR-Basic
02 100387 RK	PRD-7,200	Residential 7,200 sq. ft.	SFR-Basic
02 102087 RK	PRD-7,200	Residential 7,200 sq. ft.	SFR-Basic
01 110716 RK	PRD-7,200	Residential 7,200 sq. ft.	Single Family Res-Combo
02 102069 RK	PRD-7,200	Residential 7,200 sq. ft.	SFR-Basic
02 101005 RK	PRD-7,200	Residential 7,200 sq. ft.	SFR-Basic
02 102071 RK	PRD-7,200	Residential 7,200 sq. ft.	SFR-Basic
02 100229 RK	PRD-7,200	Residential 7,200 sq. ft.	SFR-Basic
02 102050 RK	PRD-7,200	Residential 7,200 sq. ft.	SFR-Basic
02 101409 RK	PRD-7,200	Residential 7,200 sq. ft.	SFR-Basic
02 100538 RK	PRD-7,200	Residential 7,200 sq. ft.	SFR-Basic
02 101001 RK	PRD-7,200	Residential 7,200 sq. ft.	SFR-Basic
02 101598 RK	PRD-7,200	Residential 7,200 sq. ft.	SFR-Basic
02 101597 RK	PRD-7,200	Residential 7,200 sq. ft.	SFR-Basic
02 100722 RK	PRD-7,200	Residential 7,200 sq. ft.	SFR-Basic
02 101002 RK	PRD-7,200	Residential 7,200 sq. ft.	SFR-Basic
02 101759 MH	RD	Rural Diversification	Double Wide
02 102171 RK	R-7,200	Residential 7,200 sq. ft.	SFR-Basic
02 101874 RK	PRD-7,200	Residential 7,200 sq. ft.	SFR-Basic
02 102799 RK	R-5	Rural-5 Acre	SFR-Basic
02 101906 RK	R-5	Rural-5 Acre	SFR-Basic
01 110795 MH	F	Forestry	Double Wide
01 110801 RK	R-5	Rural-5 Acre	Single Family Res-Combo
02 102501 RK	R-5	Rural-5 Acre	SFR-Basic
02 100119 RK	R-5	Rural-5 Acre	Single Family Res-Combo
02 100125 RK	R-5	Rural-5 Acre	Single Family Res-Combo
02 108366 RK	R-5	Rural-5 Acre	SFR-Basic
02 101020 RK	R-5	Rural-5 Acre	SFR-Basic
02 103626 RK	R-5	Rural-5 Acre	SFR-Basic
02 104615 RK	R-5	Rural-5 Acre	SFR-Basic
02 105881 RK	R-5	Rural-5 Acre	SFR-Basic
01 112877 RK	R-5	Rural-5 Acre	SFR-Basic
02 108367 RK	R-5	Rural-5 Acre	SFR-Basic
02 105878 RK	R-5	Rural-5 Acre	SFR-Basic
02 103757 RK	R-5	Rural-5 Acre	SFR-Basic
01 112876 RK	R-5	Rural-5 Acre	SFR-Basic
02 101910 RK	R-5	Rural-5 Acre	SFR-Basic
02 103190 RK	R-5	Rural-5 Acre	SFR-Basic
02 103193 RK	R-5	Rural-5 Acre	SFR-Basic
02 101872 RK	R-5	Rural-5 Acre	SFR-Basic
02 102806 RK	R-5	Rural-5 Acre	SFR-Basic
01 112878 RK	R-5	Rural-5 Acre	SFR-Basic
01 101959 RK	R-5	Rural-5 Acre	Single Family Res-Combo
02 101870 RK	R-5	Rural-5 Acre	SFR-Basic

Accessory Dwelling Units

Index # - File Name: 1.0022 - Single Family Dwellings Data\_Snohomish County.pdf

02 103589 RK	R-5	Rural-5 Acre	SFR-Basic
02 103246 RK	R-5	Rural-5 Acre	SFR-Basic
02 107589 RK	R-5	Rural-5 Acre	SFR-Basic
01 108081 RK	R-5	Rural-5 Acre	Single Family Res-Combo
02 104509 RK	R-5	Rural-5 Acre	Single Family Res-Combo
02 105927 RK	R-7,200	Residential 7,200 sq. ft.	Single Family Res-Combo
02 102172 RK	R-7,200	Residential 7,200 sq. ft.	SFR-Basic
02 102173 RK	R-7,200	Residential 7,200 sq. ft.	SFR-Basic
01 113639 RK	R-7,200	Residential 7,200 sq. ft.	Single Family Res-Combo
01 112085 RK	R-7,200	Residential 7,200 sq. ft.	Single Family Res-Combo
01 113641 RK	R-7,200	Residential 7,200 sq. ft.	SFR-Basic
02 105923 RK	R-7,200	Residential 7,200 sq. ft.	Single Family Res-Combo
02 105915 RK	R-7,200	Residential 7,200 sq. ft.	SFR-Basic
02 103991 RK	R-7,200	Residential 7,200 sq. ft.	Single Family Res-Combo
02 102801 RK	PRD-9,600	Residential 9,600 sq. ft.	SFR-Basic
02 102800 RK	PRD-9,600	Residential 9,600 sq. ft.	SFR-Basic
02 100292 RK	PRD-9,600	Residential 9,600 sq. ft.	SFR-Basic
02 100876 RK	PRD-9,600	Residential 9,600 sq. ft.	SFR-Basic
02 100873 RK	PRD-9,600	Residential 9,600 sq. ft.	SFR-Basic
02 101810 RK	PRD-9,600	Residential 9,600 sq. ft.	SFR-Basic
02 100870 RK	PRD-9,600	Residential 9,600 sq. ft.	SFR-Basic
02 101813 RK	PRD-9,600	Residential 9,600 sq. ft.	SFR-Basic
02 101811 RK	PRD-9,600	Residential 9,600 sq. ft.	SFR-Basic
02 100869 RK	PRD-9,600	Residential 9,600 sq. ft.	SFR-Basic
02 101815 RK	PRD-9,600	Residential 9,600 sq. ft.	SFR-Basic
02 100297 RK	PRD-9,600	Residential 9,600 sq. ft.	SFR-Basic
02 103355 RK	PRD-9,600	Residential 9,600 sq. ft.	SFR-Basic
02 104083 RK	PRD-9,600	Residential 9,600 sq. ft.	SFR-Basic
02 102797 RK	PRD-9,600	Residential 9,600 sq. ft.	SFR-Basic
02 102798 RK	PRD-9,600	Residential 9,600 sq. ft.	SFR-Basic
02 103357 RK	PRD-9,600	Residential 9,600 sq. ft.	SFR-Basic
02 104082 RK	PRD-9,600	Residential 9,600 sq. ft.	SFR-Basic
02 103356 RK	PRD-9,600	Residential 9,600 sq. ft.	SFR-Basic
02 104080 RK	PRD-9,600	Residential 9,600 sq. ft.	SFR-Basic
02 103358 RK	PRD-9,600	Residential 9,600 sq. ft.	SFR-Basic
02 104079 RK	PRD-9,600	Residential 9,600 sq. ft.	SFR-Basic
02 104078 RK	PRD-9,600	Residential 9,600 sq. ft.	SFR-Basic
02 104087 RK	PRD-9,600	Residential 9,600 sq. ft.	SFR-Basic
02 104086 RK	PRD-9,600	Residential 9,600 sq. ft.	SFR-Basic
02 104085 RK	PRD-9,600	Residential 9,600 sq. ft.	SFR-Basic
02 104084 RK	PRD-9,600	Residential 9,600 sq. ft.	SFR-Basic
02 103354 RK	PRD-9,600	Residential 9,600 sq. ft.	SFR-Basic
02 100872 RK	PRD-9,600	Residential 9,600 sq. ft.	SFR-Basic
02 100291 RK	PRD-9,600	Residential 9,600 sq. ft.	SFR-Basic
01 111998 RK	PRD-9,600	Residential 9,600 sq. ft.	Single Family Res-Combo
02 100294 RK	PRD-9,600	Residential 9,600 sq. ft.	SFR-Basic
01 113071 RK	PRD-9,600	Residential 9,600 sq. ft.	SFR-Basic

Accessory Dwelling Units

Index # - File Name: 1.0022 - Single Family Dwellings Data\_Snohomish County.pdf

01 111899 RK	R-5	Rural-5 Acre	Single Family Res-Combo
02 103921 MH	R-5	Rural-5 Acre	Double Wide
02 109357 RK	R-5	Rural-5 Acre	Single Family Res-Combo
02 103918 MH	R-5	Rural-5 Acre	Double Wide
01 112992 RK	R-5	Rural-5 Acre	Single Family Res-Combo
02 101909 RK	R-5	Rural-5 Acre	SFR-Basic
02 101913 RK	R-5	Rural-5 Acre	SFR-Basic
02 101919 RK	R-5	Rural-5 Acre	SFR-Basic
02 103636 RK	R-5	Rural-5 Acre	Single Family Res-Combo
02 101917 RK	R-5	Rural-5 Acre	SFR-Basic
02 101920 RK	R-5	Rural-5 Acre	SFR-Basic
02 109522 RK	R-5	Rural-5 Acre	Single Family Res-Combo
02 109095 RK	R-5	Rural-5 Acre	SFR-Basic
02 109260 RK	R-5	Rural-5 Acre	SFR-Basic
02 108645 RK	R-5	Rural-5 Acre	SFR-Basic
02 108389 RK	R-5	Rural-5 Acre	Single Family Res-Combo
02 104166 RK	R-5	Rural-5 Acre	Single Family Res-Combo
02 109773 RK	R-5	Rural-5 Acre	Single Family Res-Combo
02 109090 RK	R-5	Rural-5 Acre	SFR-Basic
02 108636 RK	R-5	Rural-5 Acre	SFR-Basic
02 108667 RK	R-5	Rural-5 Acre	SFR-Basic
02 109093 RK	R-5	Rural-5 Acre	SFR-Basic
02 108668 RK	R-5	Rural-5 Acre	SFR-Basic
02 107026 RK	R-5	Rural-5 Acre	Single Family Res-Combo
02 109094 RK	R-5	Rural-5 Acre	SFR-Basic
02 107559 RK	R-5	Rural-5 Acre	Single Family Res-Combo
02 107996 RK	R-5	Rural-5 Acre	SFR-Basic
02 106620 RK	R-5	Rural-5 Acre	Single Family Res-Combo
02 105194 RK	R-5	Rural-5 Acre	Single Family Res-Combo
02 106710 RK	R-5	Rural-5 Acre	Single Family Res-Combo
02 107555 RK	R-5	Rural-5 Acre	Single Family Res-Combo
02 104162 RK	R-5	Rural-5 Acre	Single Family Res-Combo
02 104667 RK	R-5	Rural-5 Acre	Single Family Res-Combo
02 107302 RK	R-5	Rural-5 Acre	Single Family Res-Combo
02 105396 RK	R-9,600	Residential 9,600 sq. ft.	SFR-Basic
02 107916 RK	R-5	Rural-5 Acre	Single Family Res-Combo
02 101088 RK	R-9,600	Residential 9,600 sq. ft.	SFR-Basic
02 101157 RK	R-9,600	Residential 9,600 sq. ft.	SFR-Basic
02 103915 RK	R-5	Rural-5 Acre	SFR-Basic
01 112523 RK	R-5	Rural-5 Acre	Single Family Res-Combo
01 108008 RK	R-5	Rural-5 Acre	Single Family Res-Combo
02 105274 RK	R-5	Rural-5 Acre	Single Family Res-Combo
02 100144 RK	R-5	Rural-5 Acre	Single Family Res-Combo
02 106961 RK	R-5	Rural-5 Acre	Single Family Res-Combo
02 106970 RK	CITY	City	Single Family Res-Combo
01 106623 MH	F	Forestry	Double Wide
02 101656 RK	R-9,600	Residential 9,600 sq. ft.	SFR-Basic



Accessory Dwelling Units

Index # - File Name: 1.0022 - Single Family Dwellings Data\_Snohomish County.pdf

02 103827 RK	R-9,600	Residential 9,600 sq. ft.	SFR-Basic
02 101658 RK	R-9,600	Residential 9,600 sq. ft.	SFR-Basic
02 101040 RK	R-9,600	Residential 9,600 sq. ft.	SFR-Basic
02 101041 RK	R-9,600	Residential 9,600 sq. ft.	SFR-Basic
02 105398 RK	R-9,600	Residential 9,600 sq. ft.	SFR-Basic
02 105397 RK	R-9,600	Residential 9,600 sq. ft.	SFR-Basic
02 105393 RK	R-9,600	Residential 9,600 sq. ft.	SFR-Basic
02 105403 RK	R-9,600	Residential 9,600 sq. ft.	SFR-Basic
02 105395 RK	R-9,600	Residential 9,600 sq. ft.	SFR-Basic
02 105399 RK	R-9,600	Residential 9,600 sq. ft.	SFR-Basic
02 105394 RK	R-9,600	Residential 9,600 sq. ft.	SFR-Basic
02 105401 RK	R-9,600	Residential 9,600 sq. ft.	SFR-Basic
02 103639 RK	R-5	Rural-5 Acre	SFR-Basic
02 105929 RK	R-5	Rural-5 Acre	Single Family Res-Combo
02 100462 RK	R-5	Rural-5 Acre	Single Family Res-Combo
02 105404 RK	R-9,600	Residential 9,600 sq. ft.	SFR-Basic
02 104931 RK	R-9,600	Residential 9,600 sq. ft.	SFR-Basic
02 101652 RK	R-9,600	Residential 9,600 sq. ft.	SFR-Basic
02 101653 RK	R-9,600	Residential 9,600 sq. ft.	SFR-Basic
02 101654 RK	R-9,600	Residential 9,600 sq. ft.	SFR-Basic
02 101655 RK	R-9,600	Residential 9,600 sq. ft.	SFR-Basic
02 101039 RK	R-9,600	Residential 9,600 sq. ft.	SFR-Basic
02 101038 RK	R-9,600	Residential 9,600 sq. ft.	SFR-Basic
01 112043 RK	R-9,600	Residential 9,600 sq. ft.	SFR-Basic
01 112044 RK	R-9,600	Residential 9,600 sq. ft.	SFR-Basic
02 106141 MH	R-5	Rural-5 Acre	Triple Wide
02 105931 RK	R-5	Rural-5 Acre	SFR-Basic
02 100864 RK	PRD-9,600	Residential 9,600 sq. ft.	SFR-Basic
02 100835 RK	PRD-9,600	Residential 9,600 sq. ft.	SFR-Basic
02 101673 RK	PRD-9,600	Residential 9,600 sq. ft.	SFR-Basic
02 101630 RK	PRD-9,600	Residential 9,600 sq. ft.	SFR-Basic
02 100162 RK	PRD-9,600	Residential 9,600 sq. ft.	SFR-Basic
02 103067 RK	R-9,600	Residential 9,600 sq. ft.	SFR-Basic
02 101165 RK	R-9,600	Residential 9,600 sq. ft.	SFR-Basic
02 100164 RK	R-9,600	Residential 9,600 sq. ft.	Single Family Res-Combo
02 100163 RK	R-9,600	Residential 9,600 sq. ft.	Single Family Res-Combo
02 100471 RK	R-9,600	Residential 9,600 sq. ft.	SFR-Basic
02 102514 RK	R-9,600	Residential 9,600 sq. ft.	SFR-Basic
02 100470 RK	R-9,600	Residential 9,600 sq. ft.	SFR-Basic
02 100472 RK	R-9,600	Residential 9,600 sq. ft.	Single Family Res-Combo
01 112298 RK	R-9,600	Residential 9,600 sq. ft.	Single Family Res-Combo
02 100124 RK	R-9,600	Residential 9,600 sq. ft.	SFR-Basic
02 109351 RK	R-9,600	Residential 9,600 sq. ft.	Single Family Res-Combo
02 102067 RK	R-5	Rural-5 Acre	Single Family Res-Combo
02 103580 RK	R-5	Rural-5 Acre	Single Family Res-Combo
02 106437 RK	R-5	Rural-5 Acre	SFR-Basic
01 112821 RK	R-5	Rural-5 Acre	Single Family Res-Combo

Accessory Dwelling Units

Index # - File Name: 1.0022 - Single Family Dwellings Data\_Snohomish County.pdf

02 106436 RK	R-5	Rural-5 Acre	SFR-Basic
02 105642 RK	R-9,600	Residential 9,600 sq. ft.	SFR-Basic
02 109115 RK	R-9,600	Residential 9,600 sq. ft.	Single Family Res-Combo
02 107115 RK	R-5	Rural-5 Acre	Single Family Res-Combo
01 112204 RK	R-9,600	Residential 9,600 sq. ft.	Single Family Res-Combo
02 109113 RK	R-9,600	Residential 9,600 sq. ft.	Single Family Res-Combo
02 108683 RK	R-9,600	Residential 9,600 sq. ft.	SFR-Basic
02 102311 RK	R-9,600	Residential 9,600 sq. ft.	Single Family Res-Combo
02 108361 RK	R-9,600	Residential 9,600 sq. ft.	Single Family Res-Combo
02 107375 RK	R-9,600	Residential 9,600 sq. ft.	Single Family Res-Combo
02 102100 RK	R-9,600	Residential 9,600 sq. ft.	SFR-Basic
02 107374 RK	R-9,600	Residential 9,600 sq. ft.	Single Family Res-Combo
02 107376 RK	R-9,600	Residential 9,600 sq. ft.	Single Family Res-Combo
02 108359 RK	R-9,600	Residential 9,600 sq. ft.	Single Family Res-Combo
02 102512 RK	R-9,600	Residential 9,600 sq. ft.	SFR-Basic
02 107428 RK	R-9,600	Residential 9,600 sq. ft.	Single Family Res-Combo
02 104250 RK	R-9,600	Residential 9,600 sq. ft.	SFR-Basic
02 107429 RK	R-9,600	Residential 9,600 sq. ft.	Single Family Res-Combo
02 107430 RK	R-9,600	Residential 9,600 sq. ft.	Single Family Res-Combo
02 105711 RK	R-9,600	Residential 9,600 sq. ft.	SFR-Basic
02 103848 MH	R-5	Rural-5 Acre	Double Wide
01 107442 RK	R-9,600	Residential 9,600 sq. ft.	Single Family Res-Combo
02 100460 RK	R-9,600	Residential 9,600 sq. ft.	Single Family Res-Combo
02 100458 RK	R-9,600	Residential 9,600 sq. ft.	Single Family Res-Combo
02 100120 RK	R-9,600	Residential 9,600 sq. ft.	SFR-Basic
02 105530 RK	R-9,600	Residential 9,600 sq. ft.	SFR-Basic
02 105709 RK	R-9,600	Residential 9,600 sq. ft.	SFR-Basic
02 105710 RK	R-9,600	Residential 9,600 sq. ft.	SFR-Basic
02 100793 RK	R-9,600	Residential 9,600 sq. ft.	Single Family Res-Combo
02 100792 RK	R-9,600	Residential 9,600 sq. ft.	Single Family Res-Combo
02 104685 RK	R-9,600	Residential 9,600 sq. ft.	SFR-Basic
02 105903 RK	R-9,600	Residential 9,600 sq. ft.	Single Family Res-Combo
02 105531 RK	R-9,600	Residential 9,600 sq. ft.	SFR-Basic
02 105529 RK	R-9,600	Residential 9,600 sq. ft.	SFR-Basic
02 105528 RK	R-9,600	Residential 9,600 sq. ft.	SFR-Basic
02 105901 RK	R-9,600	Residential 9,600 sq. ft.	Single Family Res-Combo
02 103685 RK	R-9,600	Residential 9,600 sq. ft.	SFR-Basic
02 101079 RK	R-9,600	Residential 9,600 sq. ft.	Single Family Res-Combo
02 103086 RK	R-9,600	Residential 9,600 sq. ft.	SFR-Basic
02 100122 RK	R-9,600	Residential 9,600 sq. ft.	Single Family Res-Combo
02 100463 RK	R-9,600	Residential 9,600 sq. ft.	Single Family Res-Combo
02 100118 RK	R-9,600	Residential 9,600 sq. ft.	SFR-Basic
01 112300 RK	R-9,600	Residential 9,600 sq. ft.	Single Family Res-Combo
02 104430 RK	R-9,600	Residential 9,600 sq. ft.	Single Family Res-Combo
01 112299 RK	R-9,600	Residential 9,600 sq. ft.	Single Family Res-Combo
02 106221 RK	R-9,600	Residential 9,600 sq. ft.	Single Family Res-Combo
02 108766 RK	R-9,600	Residential 9,600 sq. ft.	SFR-Basic

Accessory Dwelling Units

Index # - File Name: 1.0022 - Single Family Dwellings Data\_Snohomish County.pdf

02 109036 RK	R-9,600	Residential 9,600 sq. ft.	SFR-Basic
02 103807 RK	R-9,600	Residential 9,600 sq. ft.	Single Family Res-Combo
02 103087 RK	R-9,600	Residential 9,600 sq. ft.	SFR-Basic
02 104846 RK	R-9,600	Residential 9,600 sq. ft.	SFR-Basic
02 108056 RK	R-9,600	Residential 9,600 sq. ft.	Single Family Res-Combo
02 108640 RK	R-9,600	Residential 9,600 sq. ft.	Single Family Res-Combo
02 108639 RK	R-9,600	Residential 9,600 sq. ft.	Single Family Res-Combo
02 108638 RK	R-9,600	Residential 9,600 sq. ft.	Single Family Res-Combo
02 108637 RK	R-9,600	Residential 9,600 sq. ft.	Single Family Res-Combo
01 112201 RK	R-9,600	Residential 9,600 sq. ft.	Single Family Res-Combo
01 112205 RK	R-9,600	Residential 9,600 sq. ft.	Single Family Res-Combo
02 102315 RK	R-9,600	Residential 9,600 sq. ft.	Single Family Res-Combo
01 112203 RK	R-9,600	Residential 9,600 sq. ft.	Single Family Res-Combo
02 109350 RK	R-9,600	Residential 9,600 sq. ft.	Single Family Res-Combo
02 104665 RK	R-5	Rural-5 Acre	Single Family Res-Combo
01 113541 RK	R-5	Rural-5 Acre	SFR-Basic
01 113543 RK	R-5	Rural-5 Acre	SFR-Basic
02 101552 RK	R-5	Rural-5 Acre	Single Family Res-Combo
02 106369 RK	R-5	Rural-5 Acre	Single Family Res-Combo
02 103545 RK	R-5	Rural-5 Acre	Single Family Res-Combo
02 102267 RK	R-5	Rural-5 Acre	Single Family Res-Combo
02 102271 RK	R-5	Rural-5 Acre	Single Family Res-Combo
02 105633 RK	R-5	Rural-5 Acre	Single Family Res-Combo
01 108248 RK	PRD-9,600	Residential 9,600 sq. ft.	SFR-Basic
02 103536 RK	R-9,600	Residential 9,600 sq. ft.	Single Family Res-Combo
02 101194 RK	R-8,400	Residential 8,400 sq. ft.	Single Family Res-Combo
02 105346 RK	R-5	Rural-5 Acre	Single Family Res-Combo
02 109613 RK	R-5	Rural-5 Acre	Single Family Res-Combo
01 113504 MH	A-10	Agriculture-10 Acre	Triple Wide
02 102248 RK	PRD-9,600	Residential 9,600 sq. ft.	SFR-Basic
02 102249 RK	PRD-9,600	Residential 9,600 sq. ft.	SFR-Basic
02 102869 RK	PRD-9,600	Residential 9,600 sq. ft.	SFR-Basic
02 102868 RK	PRD-9,600	Residential 9,600 sq. ft.	SFR-Basic
02 101436 RK	PRD-9,600	Residential 9,600 sq. ft.	SFR-Basic
02 100467 RK	PRD-9,600	Residential 9,600 sq. ft.	SFR-Basic
02 102867 RK	PRD-9,600	Residential 9,600 sq. ft.	SFR-Basic
02 102866 RK	PRD-9,600	Residential 9,600 sq. ft.	SFR-Basic
02 102865 RK	PRD-9,600	Residential 9,600 sq. ft.	SFR-Basic
02 102864 RK	PRD-9,600	Residential 9,600 sq. ft.	SFR-Basic
02 102863 RK	PRD-9,600	Residential 9,600 sq. ft.	SFR-Basic
02 102252 RK	PRD-9,600	Residential 9,600 sq. ft.	SFR-Basic
02 102253 RK	PRD-9,600	Residential 9,600 sq. ft.	SFR-Basic
02 102254 RK	PRD-9,600	Residential 9,600 sq. ft.	SFR-Basic
01 107584 RK	PRD-9,600	Residential 9,600 sq. ft.	SFR-Basic
01 108287 RK	PRD-9,600	Residential 9,600 sq. ft.	SFR-Basic
02 101841 RK	R-5	Rural-5 Acre	SFR-Basic
02 104104 RK	R-5	Rural-5 Acre	Single Family Res-Combo

Accessory Dwelling Units

Index # - File Name: 1.0022 - Single Family Dwellings Data\_Snohomish County.pdf

01 108284 RK	PRD-9,600	Residential 9,600 sq. ft.	SFR-Basic
02 101593 RK	PRD-9,600	Residential 9,600 sq. ft.	SFR-Basic
02 100468 RK	PRD-9,600	Residential 9,600 sq. ft.	SFR-Basic
02 101591 RK	PRD-9,600	Residential 9,600 sq. ft.	SFR-Basic
02 100928 RK	R-5	Rural-5 Acre	Single Family Res-Combo
02 106977 RK	R-5	Rural-5 Acre	SFR-Basic
01 113041 RK	R-5	Rural-5 Acre	Single Family Res-Combo
02 103593 RK	R-9,600	Residential 9,600 sq. ft.	Single Family Res-Combo
02 105554 RK	R-9,600	Residential 9,600 sq. ft.	Single Family Res-Combo
02 100484 RK	R-9,600	Residential 9,600 sq. ft.	Single Family Res-Combo
02 100486 RK	R-9,600	Residential 9,600 sq. ft.	Single Family Res-Combo
02 102300 RK	R-9,600	Residential 9,600 sq. ft.	Single Family Res-Combo
02 106312 RK	R-9,600	Residential 9,600 sq. ft.	Single Family Res-Combo
02 107033 RK	R-9,600	Residential 9,600 sq. ft.	Single Family Res-Combo
02 105555 RK	R-9,600	Residential 9,600 sq. ft.	Single Family Res-Combo
02 105553 RK	R-9,600	Residential 9,600 sq. ft.	Single Family Res-Combo
01 107915 RK	R-9,600	Residential 9,600 sq. ft.	Single Family Res-Combo
02 103982 RK	R-9,600	Residential 9,600 sq. ft.	Single Family Res-Combo
02 104721 RK	R-9,600	Residential 9,600 sq. ft.	Single Family Res-Combo
02 101707 RK	R-9,600	Residential 9,600 sq. ft.	Single Family Res-Combo
02 104203 MH	CITY	City	Triple Wide
02 102777 RK	R-5	Rural-5 Acre	Single Family Res-Combo
02 100432 RK	R-5	Rural-5 Acre	Single Family Res-Combo
02 100805 RK	R-5	Rural-5 Acre	Single Family Res-Combo
01 103482 RK	R-5	Rural-5 Acre	Single Family Res-Combo
01 110597 RK	R-5	Rural-5 Acre	SFR-Basic
02 100865 RK	PRD-9,600	Residential 9,600 sq. ft.	SFR-Basic
02 100780 RK	F	Forestry	Single Family Res-Combo
02 102537 RK	R-5	Rural-5 Acre	Single Family Res-Combo
02 108040 RK	CITY	City	Single Family Res-Combo
01 107389 RK	R-5	Rural-5 Acre	Single Family Res-Combo
02 105945 RK	R-5	Rural-5 Acre	SFR-Basic
02 100202 RK	R-5	Rural-5 Acre	Single Family Res-Combo
02 105400 RK	PRD SA-1	Suburban Agriculture-1 Acre	SFR-Basic
02 105344 RK	PRD SA-1	Suburban Agriculture-1 Acre	SFR-Basic
02 105402 RK	PRD SA-1	Suburban Agriculture-1 Acre	SFR-Basic
02 107849 RK	PRD SA-1	Suburban Agriculture-1 Acre	SFR-Basic
02 103499 RK	PRD SA-1	Suburban Agriculture-1 Acre	Single Family Res-Combo
02 105408 RK	PRD SA-1	Suburban Agriculture-1 Acre	SFR-Basic
02 103446 RK	PRD SA-1	Suburban Agriculture-1 Acre	SFR-Basic
02 108537 RK	PRD SA-1	Suburban Agriculture-1 Acre	SFR-Basic
02 107491 RK	PRD SA-1	Suburban Agriculture-1 Acre	Single Family Res-Combo
01 107417 RK	PRD SA-1	Suburban Agriculture-1 Acre	SFR-Basic
01 107419 RK	PRD SA-1	Suburban Agriculture-1 Acre	SFR-Basic
02 102344 RK	PRD SA-1	Suburban Agriculture-1 Acre	SFR-Basic
02 102345 RK	PRD SA-1	Suburban Agriculture-1 Acre	SFR-Basic
02 105406 RK	PRD SA-1	Suburban Agriculture-1 Acre	SFR-Basic

Accessory Dwelling Units

Index # - File Name: 1.0022 - Single Family Dwellings Data\_Snohomish County.pdf

02 100438 RK	PRD SA-1	Suburban Agriculture-1 Acre SFR-Basic	
02 104664 RK	PRD SA-1	Suburban Agriculture-1 Acre SFR-Basic	
02 102334 RK	R-5	Rural-5 Acre	Single Family Res-Combo
02 101036 RK	R-5	Rural-5 Acre	Single Family Res-Combo
01 105202 RK	F	Forestry	Single Family Res-Combo
02 101051 RK	PRD-9,600	Residential 9,600 sq. ft.	Single Family Res-Combo
02 108500 RK	R-7,200	Residential 7,200 sq. ft.	Single Family Res-Combo
02 106837 RK	R-5	Rural-5 Acre	Single Family Res-Combo
01 108217 RK	R-5	Rural-5 Acre	Single Family Res-Combo
02 101219 RK			Single Family Res-Combo
01 113742 RK	R-5	Rural-5 Acre	Single Family Res-Combo
02 103781 RK	F	Forestry	Single Family Res-Combo
02 108285 RK	R-5	Rural-5 Acre	Accessory Apt Detached-Combo
01 110731 RK	RRT-10	Rural Resource Transition-10	Single Family Res-Combo
01 111808 RK	R-5	Rural-5 Acre	Single Family Res-Combo
02 106621 RK	R-5	Rural-5 Acre	Single Family Res-Combo
02 107700 RK	R-5	Rural-5 Acre	Single Family Res-Combo
01 110782 RK	R-5	Rural-5 Acre	SFR-Basic
00 102251 000 01 RK	R-5	Rural-5 Acre	Single Family Res-Combo
01 108182 RK	R-5	Rural-5 Acre	Single Family Res-Combo
02 108943 RK	R-5	Rural-5 Acre	Single Family Res-Combo
02 102047 MH	R-5	Rural-5 Acre	Triple Wide
01 104548 RK	R-5	Rural-5 Acre	Single Family Res-Combo
02 107920 MH	R-5	Rural-5 Acre	Double Wide
02 101795 RK	R-5	Rural-5 Acre	Single Family Res-Combo
02 102335 RK	R-5	Rural-5 Acre	Single Family Res-Combo
98 104130 000 01 RK	PRD SA-1	Suburban Agriculture-1 Acre	Single Family Res-Combo
02 103970 RK	PRD SA-1	Suburban Agriculture-1 Acre	Single Family Res-Combo
00 107446 RK	PRD SA-1	Suburban Agriculture-1 Acre	SFR-Basic
00 107445 RK	PRD SA-1	Suburban Agriculture-1 Acre	SFR-Basic
02 103972 RK	PRD SA-1	Suburban Agriculture-1 Acre	Single Family Res-Combo
02 101854 MH	R-5	Rural-5 Acre	Single Wide
02 108568 RK	R-5	Rural-5 Acre	Single Family Res-Combo
01 112105 RK	R-5	Rural-5 Acre	Single Family Res-Combo
02 101862 RK	R-5	Rural-5 Acre	Single Family Res-Combo
02 100907 RK	R-5	Rural-5 Acre	Single Family Res-Combo
02 108893 MH	R-5	Rural-5 Acre	Double Wide
01 105656 RK	R-5	Rural-5 Acre	Single Family Res-Combo
02 106113 RK	R-5	Rural-5 Acre	Single Family Res-Combo
02 103678 RK	CITY	City	SFR-Basic
02 102295 RK	CITY	City	SFR-Basic
02 101789 RK	R-5	Rural-5 Acre	Single Family Res-Combo
99 104192 000 01 RK	R-5	Rural-5 Acre	Single Family Res-Combo
02 104443 RK	R-5	Rural-5 Acre	Single Family Res-Combo
02 106582 RK	CITY	City	Single Family Res-Combo
02 100327 RK	R-5	Rural-5 Acre	Single Family Res-Combo
02 104063 RK	R-5 : RC	Rural Conservation : Rural-5	Single Family Res-Combo

Accessory Dwelling Units

Index # - File Name: 1.0022 - Single Family Dwellings Data\_Snohomish County.pdf

02 108830 RK	R-5	Rural-5 Acre	SFR-Basic
02 104306 RK	R-5	Rural-5 Acre	Single Family Res-Combo
01 113393 MH	R-5	Rural-5 Acre	Double Wide
00 107693 000 01 RK	R-5	Rural-5 Acre	Single Family Res-Combo
02 103421 RK	R-5	Rural-5 Acre	Single Family Res-Combo
02 105900 RK	F	Forestry	Single Family Res-Combo
02 100532 RK	R-5	Rural-5 Acre	Single Family Res-Combo
02 102077 MH	R-5	Rural-5 Acre	Double Wide
02 101583 RK	R-5	Rural-5 Acre	Single Family Res-Combo
02 103256 RK	R-5	Rural-5 Acre	Single Family Res-Combo
02 103857 RK	R-5	Rural-5 Acre	Single Family Res-Combo
02 106115 RK	R-5	Rural-5 Acre	Single Family Res-Combo
00 109374 MH	F	Forestry	Double Wide
02 104378 RK	R-5	Rural-5 Acre	Single Family Res-Combo
01 110975 RK	R-5	Rural-5 Acre	Single Family Res-Combo
02 106159 MH	R-5	Rural-5 Acre	Double Wide
02 102808 RK	R-5	Rural-5 Acre	Duplex-Combo
02 101575 RK	R-5	Rural-5 Acre	Single Family Res-Combo
01 111565 RK	F	Forestry	Single Family Res-Combo
01 111567 MH	F	Forestry	Double Wide
02 106004 RK	R-5	Rural-5 Acre	Single Family Res-Combo
02 105566 RK	R-5	Rural-5 Acre	Accessory Apt Detached-Combo
02 107025 RK	R-5	Rural-5 Acre	Single Family Res-Combo
02 107192 MH	NB : R-5	Neighborhood Business : Ru	Single Wide
01 112489 RK	A-10	Agriculture-10 Acre	Single Family Res-Combo
02 102324 RK	R-5	Rural-5 Acre	Single Family Res-Combo
02 107931 RK	R-5	Rural-5 Acre	Single Family Res-Combo
02 105643 RK	R-5	Rural-5 Acre	Single Family Res-Combo
02 103974 RK	R-5	Rural-5 Acre	Single Family Res-Combo
02 109652 RK	R-5	Rural-5 Acre	Single Family Res-Combo
01 107124 RK	R-5	Rural-5 Acre	Single Family Res-Combo
01 111169 RK	F	Forestry	Single Family Res-Combo
01 113591 MH	R-5	Rural-5 Acre	Single Wide
02 108455 MH	R-5	Rural-5 Acre	Double Wide
02 102813 RK	A-10	Agriculture-10 Acre	Single Family Res-Combo
02 106909 MH	A-10	Agriculture-10 Acre	Double Wide
01 112972 RK	F	Forestry	Single Family Res-Combo
02 100451 MH	R-5	Rural-5 Acre	Double Wide
01 105058 MH	R-5	Rural-5 Acre	Double Wide
02 106332 RK	R-5	Rural-5 Acre	SFR-Basic
02 103937 RK	R-5	Rural-5 Acre	Single Family Res-Combo
01 107909 RK	A-10	Agriculture-10 Acre	Single Family Res-Combo
00 102977 000 01 RK	R-5	Rural-5 Acre	Single Family Res-Combo
02 105715 MH	LDMR	Low Density Multiple Reside	Double Wide
00 107051 RK	F	Forestry	Single Family Res-Combo
02 110403 RK	R-5	Rural-5 Acre	Single Family Res-Combo
02 106956 RK	R-5	Rural-5 Acre	Single Family Res-Combo

Accessory Dwelling Units

Index # - File Name: 1.0022 - Single Family Dwellings Data\_Snohomish County.pdf

00 106473 RK	R-5	Rural-5 Acre	Single Family Res-Combo
02 100233 RK	R-5	Rural-5 Acre	Single Family Res-Combo
01 111859 RK	R-8,400	Residential 8,400 sq. ft.	SFR-Basic
02 101431 RK	WFB	Waterfront Beach	Single Family Res-Combo
02 101594 001 00 RK	WFB	Waterfront Beach	Duplex-Combo
02 104142 RK	MR	Multiple Residential	Duplex-Combo
02 105385 RK	R-9,600	Residential 9,600 sq. ft.	Single Family Res-Combo
01 113376 MH	R-12,500	Residential 12,500 sq. ft.	Double Wide
02 109485 RK	R-5	Rural-5 Acre	Single Family Res-Combo
02 103114 RK	R-5	Rural-5 Acre	Single Family Res-Combo
02 105635 RK	R-5	Rural-5 Acre	SFR-Basic
02 104710 RK	R-5	Rural-5 Acre	Single Family Res-Combo
02 106252 MH	R-5	Rural-5 Acre	Double Wide
01 107846 RK	R-5	Rural-5 Acre	Single Family Res-Combo
02 108758 RK	R-5	Rural-5 Acre	Single Family Res-Combo
00 102679 RK	F	Forestry	Single Family Res-Combo
99 112908 MH	F	Forestry	Triple Wide
01 113622 MH	F	Forestry	Double Wide
02 105354 MH	F	Forestry	Double Wide
02 101542 RK	F	Forestry	SFR-Basic
02 105575 RK	F	Forestry	Single Family Res-Combo
02 106372 MH	F	Forestry	Double Wide
02 100855 MH	F	Forestry	Double Wide
01 113604 RK	F	Forestry	Single Family Res-Combo
01 112751 RK	MR : R-9,600	Multiple Residential : Reside	Single Family Res-Combo
01 112945 RK	R-8,400	Residential 8,400 sq. ft.	Single Family Res-Combo
02 101602 RK	R-5	Rural-5 Acre	Single Family Res-Combo
02 102539 RK	R-12,500	Residential 12,500 sq. ft.	Single Family Res-Combo
02 102493 MH	R-5	Rural-5 Acre	Double Wide
02 102101 RK	R-5	Rural-5 Acre	Single Family Res-Combo
02 108426 RK	R-8,400	Residential 8,400 sq. ft.	SFR-Basic
98 108427 000 01 RK	R-5	Rural-5 Acre	Single Family Res-Combo
02 105858 RK	R-5	Rural-5 Acre	Single Family Res-Combo
02 107217 RK	R-5	Rural-5 Acre	Single Family Res-Combo
02 106226 MH	R-5	Rural-5 Acre	Double Wide
02 100353 RK	R-5	Rural-5 Acre	Single Family Res-Combo
02 104432 MH	A-10	Agriculture-10 Acre	Triple Wide
02 107178 MH	R-5	Rural-5 Acre	Double Wide
02 106625 RK	R-5	Rural-5 Acre	Single Family Res-Combo
02 105202 RK	R-5	Rural-5 Acre	Single Family Res-Combo
02 104373 RK	R-5	Rural-5 Acre	Single Family Res-Combo
02 103725 RK	R-5	Rural-5 Acre	Single Family Res-Combo
02 100071 RK	R-5	Rural-5 Acre	Single Family Res-Combo
02 103386 RK	R-5	Rural-5 Acre	Single Family Res-Combo
02 100009 RK	R-5	Rural-5 Acre	Single Family Res-Combo
02 109435 RK	R-5	Rural-5 Acre	Single Family Res-Combo
02 103677 RK	R-9,600	Residential 9,600 sq. ft.	Single Family Res-Combo

Accessory Dwelling Units

Index # - File Name: 1.0022 - Single Family Dwellings Data\_Snohomish County.pdf

02 105382 MH	R-5	Rural-5 Acre	Triple Wide
01 107273 MH	R-5	Rural-5 Acre	Double Wide
02 100898 RK	R-5	Rural-5 Acre	Single Family Res-Combo
02 100330 RK	R-5	Rural-5 Acre	Single Family Res-Combo
02 107304 RK	R-5	Rural-5 Acre	Single Family Res-Combo
01 111900 RK	R-5	Rural-5 Acre	Single Family Res-Combo
01 106335 RK	R-5	Rural-5 Acre	Accessory Apt Detached-Combo
99 113727 000 01 RK	R-5	Rural-5 Acre	Single Family Res-Combo
02 104323 RK	PRD SA-1	Suburban Agriculture-1 Acre	Single Family Res-Combo
02 102279 MH	PRD-12,500(M	Residential 12,500 sq. ft.	Double Wide
02 104020 RK	PRD SA-1	Suburban Agriculture-1 Acre	Single Family Res-Combo
02 100091 MH	R-5	Rural-5 Acre	Double Wide
02 109669 MH	F	Forestry	Double Wide
02 102628 RK	R-9,600	Residential 9,600 sq. ft.	Single Family Res-Combo
02 100321 RK	MR	Multiple Residential	Duplex-Combo
02 107240 RK	R-8,400	Residential 8,400 sq. ft.	Single Family Res-Combo
02 102063 RK	R-5	Rural-5 Acre	Single Family Res-Combo
00 107089 RK	WFB	Waterfront Beach	Single Family Res-Combo
02 108505 MH	R-7,200	Residential 7,200 sq. ft.	Double Wide
02 103583 RK	R-8,400	Residential 8,400 sq. ft.	Single Family Res-Combo
02 102849 RK	WFB	Waterfront Beach	Single Family Res-Combo
02 109692 MH	R-7,200	Residential 7,200 sq. ft.	Triple Wide
02 102234 RK	R-7,200	Residential 7,200 sq. ft.	Duplex-Basic
02 107280 RK	R-7,200	Residential 7,200 sq. ft.	Duplex-Basic
01 111987 MH	R-9,600	Residential 9,600 sq. ft.	Double Wide
02 101222 RK	R-7,200	Residential 7,200 sq. ft.	Single Family Res-Combo
01 112422 RK	R-9,600	Residential 9,600 sq. ft.	Single Family Res-Combo
02 100198 RK	R-5	Rural-5 Acre	Single Family Res-Combo
02 107534 RK	CITY	City	Single Family Res-Combo
01 100413 RK	CITY	City	Single Family Res-Combo
02 105367 RK	R-5	Rural-5 Acre	SFR-Basic
00 108731 MH	R-5	Rural-5 Acre	Double Wide
02 103240 MH	R-5	Rural-5 Acre	Triple Wide
02 109432 RK	R-5	Rural-5 Acre	Single Family Res-Combo
01 111184 RK	R-5	Rural-5 Acre	Single Family Res-Combo
02 103898 RK	R-5	Rural-5 Acre	Single Family Res-Combo
02 103439 RK	R-7,200	Residential 7,200 sq. ft.	Single Family Res-Combo
02 102519 RK	R-5	Rural-5 Acre	Single Family Res-Combo
02 107049 RK	R-5	Rural-5 Acre	Accessory Apt Detached-Combo
01 104876 RK	CITY	City	Single Family Res-Combo
01 108098 RK	R-5	Rural-5 Acre	Single Family Res-Combo
01 113476 RK	R-5	Rural-5 Acre	Duplex-Combo
02 102583 MH	R-5	Rural-5 Acre	Double Wide
01 112708 RK	RRT-10	Rural Resource Transition-10	Accessory Apt Detached-Combo
02 103612 RK	R-5	Rural-5 Acre	Single Family Res-Combo
02 104375 RK	R-5	Rural-5 Acre	Single Family Res-Combo
02 101450 RK	R-5	Rural-5 Acre	Single Family Res-Combo



Accessory Dwelling Units

Index # - File Name: 1.0022 - Single Family Dwellings Data\_Snohomish County.pdf

01 112959 RK	CITY	City	Single Family Res-Combo
02 108099 RK	R-5	Rural-5 Acre	Accessory Apt Detached-Combo
01 111866 RK	A-10	Agriculture-10 Acre	Single Family Res-Combo
02 109333 MH	R-5	Rural-5 Acre	Double Wide
02 106298 MH	R-5	Rural-5 Acre	Double Wide
01 112641 RK	R-5	Rural-5 Acre	Single Family Res-Combo
02 106713 RK	RRT-10	Rural Resource Transition-10	Single Family Res-Combo
02 106375 RK	RRT-10	Rural Resource Transition-10	Single Family Res-Combo
02 101406 MH	R-5	Rural-5 Acre	Double Wide
01 106325 RK	R-5	Rural-5 Acre	Single Family Res-Combo
02 104226 RK	CITY	City	Single Family Res-Combo
01 107293 RK	R-5	Rural-5 Acre	Single Family Res-Combo
02 104538 RK	CITY	City	Single Family Res-Combo
02 100201 RK	R-9,600	Residential 9,600 sq. ft.	Single Family Res-Combo
02 109092 RK	CITY	City	Single Family Res-Combo
00 101409 RK	CITY	City	Single Family Res-Combo
02 104790 MH	R-5	Rural-5 Acre	Double Wide
01 110591 RK	CITY	City	Duplex-Basic
01 110859 RK	RRT-10	Rural Resource Transition-10	Single Family Res-Combo
02 108206 RK	RRT-10	Rural Resource Transition-10	Single Family Res-Combo
02 100455 RK	R-5	Rural-5 Acre	Single Family Res-Combo
01 107465 RK	CITY	City	Single Family Res-Combo
02 100271 MH	R-5	Rural-5 Acre	Double Wide
02 104955 RK	R-5	Rural-5 Acre	SFR-Basic
02 107750 RK	R-5	Rural-5 Acre	Single Family Res-Combo
02 107748 RK	R-5	Rural-5 Acre	Single Family Res-Combo
02 109367 RK	R-5	Rural-5 Acre	SFR-Basic
02 104787 RK	R-5	Rural-5 Acre	SFR-Basic
02 104788 RK	R-5	Rural-5 Acre	SFR-Basic
02 100211 MH	R-5	Rural-5 Acre	Double Wide
02 103962 MH	RRT-10	Rural Resource Transition-10	Single Wide
02 107493 RK	R-5	Rural-5 Acre	Accessory Apt Detached-Combo
01 112984 RK	RRT-10	Rural Resource Transition-10	Single Family Res-Combo
01 104248 RK	R-5	Rural-5 Acre	Single Family Res-Combo
02 105011 RK	R-5	Rural-5 Acre	Single Family Res-Combo
02 100965 RK	R-5	Rural-5 Acre	Single Family Res-Combo
02 104371 RK	R-5	Rural-5 Acre	Single Family Res-Combo
00 104097 000 01 RK	R-5	Rural-5 Acre	Single Family Res-Combo
00 107285 000 01 RK	R-5	Rural-5 Acre	Single Family Res-Combo
02 104105 RK	R-5	Rural-5 Acre	Single Family Res-Combo
02 100951 MH	R-5	Rural-5 Acre	Double Wide
02 108085 RK	R-5	Rural-5 Acre	Single Family Res-Combo
02 103034 RK	CITY	City	Single Family Res-Combo
02 103696 RK	R-5	Rural-5 Acre	Single Family Res-Combo
02 107010 RK	R-5	Rural-5 Acre	Single Family Res-Combo
02 103287 RK	R-5	Rural-5 Acre	Single Family Res-Combo
00 102452 000 01 RK	R-5	Rural-5 Acre	Single Family Res-Combo

Accessory Dwelling Units

Index # - File Name: 1.0022 - Single Family Dwellings Data\_Snohomish County.pdf

02 104794 RK	R-5	Rural-5 Acre	Single Family Res-Combo
02 103494 MH	R-5	Rural-5 Acre	Double Wide
02 100044 RK	R-5	Rural-5 Acre	Single Family Res-Combo
02 104116 RK	R-5	Rural-5 Acre	Single Family Res-Combo
02 104277 RK	R-5	Rural-5 Acre	Single Family Res-Combo
02 103754 RK	R-5	Rural-5 Acre	Single Family Res-Combo
02 106477 RK	R-7,200	Residential 7,200 sq. ft.	SFR-Basic
02 105263 RK	R-5	Rural-5 Acre	Single Family Res-Combo
02 107722 RK	R-5	Rural-5 Acre	Single Family Res-Combo
02 107726 RK	R-5	Rural-5 Acre	Single Family Res-Combo
02 105952 RK	CITY	City	Single Family Res-Combo
02 100072 MH	R-5	Rural-5 Acre	Double Wide
02 105885 RK	R-5	Rural-5 Acre	Single Family Res-Combo
00 104970 000 01 RK	R-5	Rural-5 Acre	Single Family Res-Combo
01 112865 RK	R-5	Rural-5 Acre	SFR-Basic
01 113558 RK	R-5	Rural-5 Acre	Single Family Res-Combo
02 100266 RK	R-5	Rural-5 Acre	SFR-Basic
02 102594 RK	R-5	Rural-5 Acre	SFR-Basic
02 102698 RK	R-5	Rural-5 Acre	SFR-Basic
02 103479 RK	R-5	Rural-5 Acre	SFR-Basic
02 105363 RK	R-5	Rural-5 Acre	SFR-Basic
00 104666 RK	R-5	Rural-5 Acre	Single Family Res-Combo
02 107077 RK	R-5	Rural-5 Acre	Single Family Res-Combo
02 105953 RK	R-5	Rural-5 Acre	Single Family Res-Combo
02 108756 RK	RC	Rural Conservation	Single Family Res-Combo
02 100269 RK	R-5	Rural-5 Acre	Single Family Res-Combo
02 103657 MH	F : R-5	Forestry : Rural-5 Acre	Double Wide
02 104356 RK	R-5	Rural-5 Acre	Single Family Res-Combo
02 100354 RK	R-5	Rural-5 Acre	Single Family Res-Combo
02 101620 RK	R-5	Rural-5 Acre	Single Family Res-Combo
02 107180 MH	R-5	Rural-5 Acre	Triple Wide
02 103735 RK	R-5	Rural-5 Acre	Single Family Res-Combo
02 108833 RK	R-5	Rural-5 Acre	Single Family Res-Combo
01 104744 RK	R-5	Rural-5 Acre	Single Family Res-Combo
02 106898 RK	R-5	Rural-5 Acre	Single Family Res-Combo
01 105279 MH	R-5	Rural-5 Acre	Double Wide
02 108921 RK	R-5	Rural-5 Acre	Single Family Res-Combo
02 105423 RK	R-5	Rural-5 Acre	Single Family Res-Combo
02 103985 RK	R-5	Rural-5 Acre	Single Family Res-Combo
02 100329 RK	R-5	Rural-5 Acre	Single Family Res-Combo
02 107008 RK	R-5	Rural-5 Acre	Single Family Res-Combo
02 104680 RK	R-5	Rural-5 Acre	Single Family Res-Combo
02 101624 RK	R-5	Rural-5 Acre	Accessory Apt Detached-Combo
01 112506 RK	R-5	Rural-5 Acre	Single Family Res-Combo
02 108823 MH	RD	Rural Diversification	Double Wide
02 104123 RK	R-5	Rural-5 Acre	Single Family Res-Combo
01 106921 RK	R-5	Rural-5 Acre	Single Family Res-Combo

Accessory Dwelling Units

Index # - File Name: 1.0022 - Single Family Dwellings Data\_Snohomish County.pdf

01 111387 RK	R-5	Rural-5 Acre	SFR-Basic
01 105753 RK	R-5	Rural-5 Acre	Single Family Res-Combo
02 100701 RK	R-5	Rural-5 Acre	Single Family Res-Combo
02 103913 MH	R-5	Rural-5 Acre	Double Wide
02 109808 RK	R-5	Rural-5 Acre	Single Family Res-Combo
02 109931 MH	R-5	Rural-5 Acre	Single Wide
02 107973 RK	R-5	Rural-5 Acre	Single Family Res-Combo
02 105345 RK	R-5	Rural-5 Acre	Single Family Res-Combo
02 101837 RK	RRT-10	Rural Resource Transition-10	Single Family Res-Combo
02 100926 MH	R-5	Rural-5 Acre	Single Wide
02 104171 RK	R-5	Rural-5 Acre	Single Family Res-Combo
01 108193 RK	R-5	Rural-5 Acre	Single Family Res-Combo
02 107147 RK	R-5	Rural-5 Acre	Single Family Res-Combo
01 113388 RK	R-5	Rural-5 Acre	Single Family Res-Combo
02 102814 RK	R-5	Rural-5 Acre	Single Family Res-Combo
02 108437 RK	R-5	Rural-5 Acre	Single Family Res-Combo
01 104651 MH	R-5	Rural-5 Acre	Triple Wide
01 111411 RK	R-5	Rural-5 Acre	Single Family Res-Combo
02 104799 RK	R-5	Rural-5 Acre	Single Family Res-Combo
02 108493 MH	R-5	Rural-5 Acre	Double Wide
02 104841 RK	R-5	Rural-5 Acre	SFR-Basic
99 110689 000 01 RK	R-9,600	Residential 9,600 sq. ft.	Single Family Res-Combo
02 107462 RK	WFB	Waterfront Beach	Single Family Res-Combo
01 111439 RK	R-5	Rural-5 Acre	SFR-Basic
02 106392 RK	R-5	Rural-5 Acre	Single Family Res-Combo
02 100074 RK	R-5	Rural-5 Acre	Single Family Res-Combo
02 106475 RK	R-5	Rural-5 Acre	Single Family Res-Combo
01 105578 RK	R-5	Rural-5 Acre	Single Family Res-Combo
02 101240 RK	F	Forestry	Single Family Res-Combo
01 112791 RK	R-5	Rural-5 Acre	Single Family Res-Combo
02 104428 RK	F	Forestry	Single Family Res-Combo
02 104562 MH	R-5	Rural-5 Acre	Double Wide
02 104913 RK	R-5	Rural-5 Acre	Single Family Res-Combo
01 112469 RK	R-5	Rural-5 Acre	Single Family Res-Combo
01 112487 RK	R-5	Rural-5 Acre	Single Family Res-Combo
01 111276 RK	R-5	Rural-5 Acre	Single Family Res-Combo
02 108845 RK	R-5	Rural-5 Acre	Single Family Res-Combo
01 105859 MH	A-10	Agriculture-10 Acre	Double Wide
02 110807 MH	R-5	Rural-5 Acre	Double Wide
02 105324 RK	R-5	Rural-5 Acre	Single Family Res-Combo
01 107689 RK	R-5	Rural-5 Acre	Single Family Res-Combo
02 104661 RK	R-5	Rural-5 Acre	Accessory Apt Detached-Combo
01 101468 RK	R-5	Rural-5 Acre	Single Family Res-Combo
01 113745 RK	R-5	Rural-5 Acre	Single Family Res-Combo
02 104451 RK	R-5	Rural-5 Acre	Single Family Res-Combo
01 112739 RK	R-5	Rural-5 Acre	Single Family Res-Combo
02 102585 RK	R-5	Rural-5 Acre	Single Family Res-Combo

Accessory Dwelling Units

Index # - File Name: 1.0022 - Single Family Dwellings Data\_Snohomish County.pdf

02 103320 RK	RRT-10	Rural Resource Transition-10	Accessory Apt Detached-Combo
02 104845 RK	R-5	Rural-5 Acre	Single Family Res-Combo
02 100047 MH	R-5	Rural-5 Acre	Double Wide
00 110352 RK	R-5	Rural-5 Acre	Single Family Res-Combo
02 108033 MH	R-5	Rural-5 Acre	Single Wide
02 107853 RK	R-5	Rural-5 Acre	Single Family Res-Combo
01 106438 RK	R-5	Rural-5 Acre	Single Family Res-Combo
01 107991 RK	R-5	Rural-5 Acre	SFR-Basic
02 100976 RK	R-5	Rural-5 Acre	Single Family Res-Combo
02 106955 RK	RD	Rural Diversification	Single Family Res-Combo
02 104261 RK	R-5	Rural-5 Acre	Single Family Res-Combo
02 106464 RK	R-5	Rural-5 Acre	Single Family Res-Combo
01 103172 MH	R-5	Rural-5 Acre	Double Wide
00 103338 RK	R-5	Rural-5 Acre	Single Family Res-Combo
02 107291 RK	R-5	Rural-5 Acre	Single Family Res-Combo
02 107343 RK	R-5	Rural-5 Acre	SFR-Basic
00 104585 RK	R-5	Rural-5 Acre	Single Family Res-Combo
01 105824 RK	R-5	Rural-5 Acre	Single Family Res-Combo
02 100446 RK	R-5	Rural-5 Acre	SFR-Basic
01 112415 RK	R-5	Rural-5 Acre	Single Family Res-Combo
02 106938 RK	A-10	Agriculture-10 Acre	Single Family Res-Combo
02 101538 RK	R-5	Rural-5 Acre	SFR-Basic
02 101177 RK	R-5	Rural-5 Acre	SFR-Basic
02 101178 RK	R-5	Rural-5 Acre	SFR-Basic
02 101536 RK	R-5	Rural-5 Acre	SFR-Basic
02 109912 RK	R-5	Rural-5 Acre	Single Family Res-Combo
02 106400 RK	R-5	Rural-5 Acre	Single Family Res-Combo
00 110399 RK	R-5	Rural-5 Acre	Single Family Res-Combo
01 107988 RK	R-5	Rural-5 Acre	SFR-Basic
01 111440 RK	R-5	Rural-5 Acre	SFR-Basic
02 101442 RK	R-5	Rural-5 Acre	Single Family Res-Combo
01 112514 RK	RD	Rural Diversification	Single Family Res-Combo
02 104954 RK	R-5	Rural-5 Acre	SFR-Basic
02 103740 RK	R-5	Rural-5 Acre	Single Family Res-Combo
02 101014 RK	R-5	Rural-5 Acre	SFR-Basic
02 108569 RK	R-5	Rural-5 Acre	Single Family Res-Combo
02 106204 RK	R-5	Rural-5 Acre	Single Family Res-Combo
02 101074 RK	CITY	City	Single Family Res-Combo
02 102164 MH	F and R	Forestry and Recreation	Double Wide
02 106240 MH	R-5	Rural-5 Acre	Double Wide
02 107993 RK	R-5	Rural-5 Acre	Single Family Res-Combo
02 108948 RK	R-5	Rural-5 Acre	SFR-Basic
02 103598 RK	A-10	Agriculture-10 Acre	Single Family Res-Combo
02 100068 RK	R-5	Rural-5 Acre	Single Family Res-Combo
02 101667 RK	RRT-10	Rural Resource Transition-10	Single Family Res-Combo
00 107598 RK	F	Forestry	Single Family Res-Combo
01 103899 RK	R-5	Rural-5 Acre	Single Family Res-Combo

Accessory Dwelling Units

Index # - File Name: 1.0022 - Single Family Dwellings Data\_Snohomish County.pdf

01 113414 RK	R-5	Rural-5 Acre	Single Family Res-Combo
01 104706 RK	R-5	Rural-5 Acre	Single Family Res-Combo
01 105367 RK	R-5	Rural-5 Acre	Single Family Res-Combo
02 106163 RK	R-5	Rural-5 Acre	Single Family Res-Combo
01 106771 RK	R-5	Rural-5 Acre	Single Family Res-Combo
02 101437 RK	R-5	Rural-5 Acre	Single Family Res-Combo
01 110941 RK	F	Forestry	Single Family Res-Combo
02 102651 RK	R-5	Rural-5 Acre	Duplex-Combo
02 102495 RK	R-5	Rural-5 Acre	Single Family Res-Combo
03 101513 RK	R-5	Rural-5 Acre	Single Family Res-Combo
03 107072 RK	R-5	Rural-5 Acre	Single Family Res-Combo
03 107051 RK	R-5	Rural-5 Acre	Single Family Res-Combo
03 102235 RK	R-5	Rural-5 Acre	Single Family Res-Combo
03 105055 RK	A-10	Agriculture-10 Acre	Single Family Res-Combo
02 106562 RK	R-5	Rural-5 Acre	Single Family Res-Combo
03 109331 RK	F	Forestry	Single Family Res-Combo
02 108473 RK	R-5	Rural-5 Acre	Single Family Res-Combo
03 104532 RK	R-5	Rural-5 Acre	Single Family Res-Combo
02 108058 RK	TRIBES	Native American Land	Single Family Res-Combo
02 110421 RK	R-5	Rural-5 Acre	Single Family Res-Combo
03 106218 RK	R-5	Rural-5 Acre	Single Family Res-Combo
03 101572 RK	R-5	Rural-5 Acre	Single Family Res-Combo
03 100034 RK	R-5	Rural-5 Acre	Single Family Res-Combo
03 105284 RK	R-5	Rural-5 Acre	Single Family Res-Combo
03 104127 MH	F	Forestry	Double Wide
03 106369 RK	R-5	Rural-5 Acre	Single Family Res-Combo
02 108330 RK	R-5	Rural-5 Acre	Single Family Res-Combo
03 100516 RK	F	Forestry	Single Family Res-Combo
03 101213 RK	R-5	Rural-5 Acre	Single Family Res-Combo
03 105023 RK	R-5	Rural-5 Acre	Single Family Res-Combo
03 100979 RK	R-5	Rural-5 Acre	Single Family Res-Combo
03 107074 MH	R-5	Rural-5 Acre	Double Wide
03 104210 RK	R-5	Rural-5 Acre	Single Family Res-Combo
03 105899 RK	R-5	Rural-5 Acre	Single Family Res-Combo
02 104219 RK	R-5	Rural-5 Acre	Single Family Res-Combo
02 108577 RK	R-5	Rural-5 Acre	Single Family Res-Combo
03 100083 RK	R-5	Rural-5 Acre	SFR-Basic
03 100175 RK	R-5	Rural-5 Acre	SFR-Basic
03 100177 RK	R-5	Rural-5 Acre	SFR-Basic
03 100184 RK	R-5	Rural-5 Acre	SFR-Basic
03 104310 RK	R-5	Rural-5 Acre	Single Family Res-Combo
01 113053 RK	R-5	Rural-5 Acre	Single Family Res-Combo
03 104605 RK	R-5	Rural-5 Acre	Single Family Res-Combo
03 105435 RK	R-5	Rural-5 Acre	Single Family Res-Combo
01 110695 MH	R-5	Rural-5 Acre	Single Wide
03 107343 RK	R-5	Rural-5 Acre	Single Family Res-Combo
99 116151 000 01 RK	F	Forestry	Single Family Res-Combo

Accessory Dwelling Units

Index # - File Name: 1.0022 - Single Family Dwellings Data\_Snohomish County.pdf

03 107081 RK	RRT-10	Rural Resource Transition-10	Single Family Res-Combo
03 103421 RK	R-5	Rural-5 Acre	Single Family Res-Combo
02 107211 RK	R-5	Rural-5 Acre	Single Family Res-Combo
03 103509 MH	R-5	Rural-5 Acre	Triple Wide
03 102966 RK	R-5	Rural-5 Acre	Single Family Res-Combo
01 101775 000 01 MH	R-5	Rural-5 Acre	Double Wide
03 104455 RK	R-5	Rural-5 Acre	Single Family Res-Combo
03 103107 RK	RD	Rural Diversification	Single Family Res-Combo
03 107316 MH	R-5	Rural-5 Acre	Double Wide
03 106632 RK	R-5	Rural-5 Acre	Single Family Res-Combo
01 101529 000 01 RK	R-5 : R-9,600	Residential 9,600 sq. ft. : Ru	Single Family Res-Combo
03 100659 MH	R-5	Rural-5 Acre	Double Wide
03 106809 RK	RC	Rural Conservation	Single Family Res-Combo
03 101810 MH	RC	Rural Conservation	Double Wide
03 101184 RK	R-5	Rural-5 Acre	Accessory Apt Detached-Combo
01 101277 000 01 RK	R-5	Rural-5 Acre	Single Family Res-Combo
02 110308 RK	R-5	Rural-5 Acre	Single Family Res-Combo
03 101175 RK	R-5	Rural-5 Acre	Single Family Res-Combo
03 102859 RK	R-5	Rural-5 Acre	Single Family Res-Combo
03 105790 RK	R-5	Rural-5 Acre	Single Family Res-Combo
03 100785 RK	RRT-10	Rural Resource Transition-10	Single Family Res-Combo
00 107414 000 01 RK	R-5	Rural-5 Acre	Single Family Res-Combo
02 109751 RK	R-5	Rural-5 Acre	Single Family Res-Combo
03 109037 RK	R-5	Rural-5 Acre	Single Family Res-Combo
03 104811 MH	R-5	Rural-5 Acre	Double Wide
02 107558 RK	F : R-5	Forestry : Rural-5 Acre	Single Family Res-Combo
01 112221 MH	RD	Rural Diversification	Double Wide
02 110338 RK	R-5	Rural-5 Acre	Single Family Res-Combo
99 111567 000 01 RK	R-5	Rural-5 Acre	Single Family Res-Combo
03 105976 RK	R-5	Rural-5 Acre	Single Family Res-Combo
03 103368 RK	R-5	Rural-5 Acre	Single Family Res-Combo
03 104109 RK	CITY	City	Single Family Res-Combo
03 111070 MH	R-5	Rural-5 Acre	Single Wide
03 107441 RK	RRT-10	Rural Resource Transition-10	Single Family Res-Combo
03 105941 RK	R-5	Rural-5 Acre	SFR-Basic
03 105932 RK	R-5	Rural-5 Acre	SFR-Basic
03 105935 RK	R-5	Rural-5 Acre	SFR-Basic
03 105004 RK	R-5	Rural-5 Acre	Single Family Res-Combo
00 108234 000 01 RK	R-5	Rural-5 Acre	Single Family Res-Combo
03 106078 RK	R-5	Rural-5 Acre	Single Family Res-Combo
03 100585 RK	R-5	Rural-5 Acre	Single Family Res-Combo
03 100703 RK	R-5	Rural-5 Acre	Single Family Res-Combo
03 104126 RK	R-5	Rural-5 Acre	Single Family Res-Combo
03 107873 RK	R-5	Rural-5 Acre	Single Family Res-Combo
03 108127 RK	R-5	Rural-5 Acre	Single Family Res-Combo
03 106954 RK	R-5	Rural-5 Acre	Single Family Res-Combo
03 108372 MH	R-5	Rural-5 Acre	Double Wide

Accessory Dwelling Units

Index # - File Name: 1.0022 - Single Family Dwellings Data\_Snohomish County.pdf

03 106829 RK	R-5	Rural-5 Acre	Single Family Res-Combo
02 107041 RK	R-5	Rural-5 Acre	Single Family Res-Combo
03 101180 RK	R-5	Rural-5 Acre	Single Family Res-Combo
03 100442 RK	R-5	Rural-5 Acre	SFR-Basic
03 103660 RK	RD	Rural Diversification	Single Family Res-Combo
03 104344 MH	R-5	Rural-5 Acre	Triple Wide
03 107005 RK	R-5	Rural-5 Acre	Single Family Res-Combo
03 102207 RK	A-10	Agriculture-10 Acre	Single Family Res-Combo
03 104400 MH	R-5	Rural-5 Acre	Double Wide
03 107460 RK	R-5	Rural-5 Acre	SFR-Basic
03 102693 MH	R-5	Rural-5 Acre	Double Wide
03 107548 RK	R-5	Rural-5 Acre	Single Family Res-Combo
03 107754 RK	R-5	Rural-5 Acre	Single Family Res-Combo
03 105787 MH	R-5	Rural-5 Acre	Double Wide
03 103787 RK	R-5	Rural-5 Acre	Single Family Res-Combo
03 100822 RK	R-5	Rural-5 Acre	Single Family Res-Combo
02 103993 RK	R-5	Rural-5 Acre	Single Family Res-Combo
02 108979 RK	R-5	Rural-5 Acre	Single Family Res-Combo
03 100674 RK	R-5	Rural-5 Acre	Single Family Res-Combo
03 103476 RK	R-5	Rural-5 Acre	Single Family Res-Combo
03 103382 RK	R-5	Rural-5 Acre	SFR-Basic
03 105430 RK	R-5	Rural-5 Acre	Single Family Res-Combo
03 108760 RK	R-5	Rural-5 Acre	Single Family Res-Combo
03 105898 MH	R-5	Rural-5 Acre	Double Wide
02 107581 RK	R-5	Rural-5 Acre	Single Family Res-Combo
03 107353 RK	R-5	Rural-5 Acre	Single Family Res-Combo
02 108940 RK	R-5	Rural-5 Acre	Single Family Res-Combo
00 104448 000 01 RK	R-5	Rural-5 Acre	Single Family Res-Combo
03 108433 RK	R-5	Rural-5 Acre	Single Family Res-Combo
03 106094 RK	R-5	Rural-5 Acre	Single Family Res-Combo
03 104345 MH	R-5	Rural-5 Acre	Double Wide
03 100368 RK	RC	Rural Conservation	Single Family Res-Combo
02 109203 RK	R-5	Rural-5 Acre	Single Family Res-Combo
03 105527 RK	R-5	Rural-5 Acre	Single Family Res-Combo
03 109637 RK	R-5	Rural-5 Acre	Single Family Res-Combo
02 105347 MH	R-5	Rural-5 Acre	Single Wide
03 108906 RK	R-5	Rural-5 Acre	SFR-Basic
03 102143 RK	R-5	Rural-5 Acre	Single Family Res-Combo
02 110564 RK	R-5	Rural-5 Acre	Single Family Res-Combo
02 109223 RK	R-5	Rural-5 Acre	Single Family Res-Combo
03 104114 RK	R-5	Rural-5 Acre	Single Family Res-Combo
03 100931 RK	R-5	Rural-5 Acre	Single Family Res-Combo
01 111636 MH	R-5	Rural-5 Acre	Double Wide
03 102664 RK	R-5	Rural-5 Acre	Single Family Res-Combo
02 107593 RK	RRT-10	Rural Resource Transition-10	Single Family Res-Combo
03 100215 MH	R-5	Rural-5 Acre	Double Wide
03 105459 RK	R-5	Rural-5 Acre	Single Family Res-Combo

Accessory Dwelling Units

Index # - File Name: 1.0022 - Single Family Dwellings Data\_Snohomish County.pdf

03 100284 MH	R-5	Rural-5 Acre	Double Wide
02 110114 RK	R-5	Rural-5 Acre	Single Family Res-Combo
99 114488 000 01 RK	R-5	Rural-5 Acre	Single Family Res-Combo
03 105397 RK	R-5	Rural-5 Acre	Single Family Res-Combo
03 105137 RK	SA-1	Suburban Agriculture-1 Acre	Single Family Res-Combo
03 100617 RK	R-5	Rural-5 Acre	Single Family Res-Combo
01 106040 MH	R-5	Rural-5 Acre	Double Wide
03 104084 RK	R-5	Rural-5 Acre	SFR-Basic
02 109793 RK	R-5	Rural-5 Acre	SFR-Basic
02 109795 RK	R-5	Rural-5 Acre	Single Family Res-Combo
03 101811 MH	R-5	Rural-5 Acre	Double Wide
03 107052 RK	CITY	City	Single Family Res-Combo
03 104202 RK	SA-1	Suburban Agriculture-1 Acre	Single Family Res-Combo
03 105741 RK	RRT-10	Rural Resource Transition-10	Single Family Res-Combo
01 100331 000 01 RK	CITY	City	Accessory Apt Detached-Combo
03 101807 MH	R-5	Rural-5 Acre	Double Wide
03 101809 MH	R-5	Rural-5 Acre	Double Wide
03 107259 RK	CITY	City	Single Family Res-Combo
03 103327 RK	R-5	Rural-5 Acre	Single Family Res-Combo
03 101891 RK	R-9,600	Residential 9,600 sq. ft.	Single Family Res-Combo
03 105059 RK	A-10 : R-5 : RC	Agriculture-10 Acre : Rural C	Single Family Res-Combo
03 105001 RK	CITY	City	Single Family Res-Combo
03 105443 RK	CITY	City	Single Family Res-Combo
03 100592 RK	R-5	Rural-5 Acre	Single Family Res-Combo
02 107173 MH	R-5	Rural-5 Acre	Double Wide
02 110203 RK	R-5	Rural-5 Acre	Single Family Res-Combo
03 103155 RK	R-5	Rural-5 Acre	Single Family Res-Combo
02 109710 RK	CITY	City	Duplex-Basic
02 109577 RK	CITY	City	Single Family Res-Combo
03 100664 RK	RRT-10	Rural Resource Transition-10	Single Family Res-Combo
02 108061 RK	R-5	Rural-5 Acre	Single Family Res-Combo
03 102963 MH	RRT-10	Rural Resource Transition-10	Double Wide
03 104802 MH	RRT-10	Rural Resource Transition-10	Double Wide
03 105427 RK	R-5	Rural-5 Acre	Single Family Res-Combo
03 105218 RK	R-5	Rural-5 Acre	Single Family Res-Combo
03 102152 RK	R-5	Rural-5 Acre	Single Family Res-Combo
03 109419 RK	CITY	City	Duplex-Combo
03 105569 RK	CITY	City	Duplex-Combo
02 110399 RK	R-5	Rural-5 Acre	Single Family Res-Combo
03 107093 RK	R-5	Rural-5 Acre	Single Family Res-Combo
02 110579 RK	R-5	Rural-5 Acre	Single Family Res-Combo
03 103753 RK	R-5	Rural-5 Acre	Single Family Res-Combo
03 108583 MH	RRT-10	Rural Resource Transition-10	Double Wide
02 110627 RK	RRT-10	Rural Resource Transition-10	Single Family Res-Combo
03 100474 RK	RRT-10	Rural Resource Transition-10	Single Family Res-Combo
03 105298 RK	R-5	Rural-5 Acre	Single Family Res-Combo
02 107550 RK	CITY	City	Single Family Res-Combo



Accessory Dwelling Units

Index # - File Name: 1.0022 - Single Family Dwellings Data\_Snohomish County.pdf

03 100544 RK	CITY	City	Single Family Res-Combo
02 108875 MH	R-5	Rural-5 Acre	Double Wide
02 108143 RK	A-10	Agriculture-10 Acre	Single Family Res-Combo
03 100757 001 00 RK	A-10 : R-5	Agriculture-10 Acre : Rural-5	Single Family Res-Combo
02 110646 RK	R-5	Rural-5 Acre	Single Family Res-Combo
03 104560 RK	R-5	Rural-5 Acre	Single Family Res-Combo
03 103102 MH	R-5	Rural-5 Acre	Triple Wide
02 110088 MH	R-5	Rural-5 Acre	Double Wide
02 110663 RK	CITY	City	Single Family Res-Combo
03 101954 RK	CITY	City	Single Family Res-Combo
02 110788 RK	CITY	City	Single Family Res-Combo
03 109021 MH	R-5	Rural-5 Acre	Double Wide
03 106208 RK	R-5	Rural-5 Acre	Single Family Res-Combo
02 106192 RK	R-5	Rural-5 Acre	Single Family Res-Combo
02 109932 MH	R-5	Rural-5 Acre	Double Wide
03 101354 001 00 RK	R-7,200	Residential 7,200 sq. ft.	Single Family Res-Combo
03 108922 MH	R-5	Rural-5 Acre	Double Wide
02 110707 RK	R-5	Rural-5 Acre	Single Family Res-Combo
02 104000 RK	R-9,600	Residential 9,600 sq. ft.	Single Family Res-Combo
03 100469 RK	R-7,200	Residential 7,200 sq. ft.	Duplex-Basic
03 100657 RK	R-7,200	Residential 7,200 sq. ft.	Duplex-Basic
03 107541 RK	WFB	Waterfront Beach	Single Family Res-Combo
02 109786 RK	R-5	Rural-5 Acre	Single Family Res-Combo
03 109088 RK	MR	Multiple Residential	Single Family Res-Combo
03 100200 RK	WFB	Waterfront Beach	Single Family Res-Combo
03 105276 RK	WFB	Waterfront Beach	Single Family Res-Combo
03 102843 RK	R-9,600	Residential 9,600 sq. ft.	SFR-Basic
03 104188 RK	CITY	City	SFR-Basic
03 104186 RK	CITY	City	SFR-Basic
03 102633 RK	R-5	Rural-5 Acre	Single Family Res-Combo
03 104207 RK	R-9,600	Residential 9,600 sq. ft.	Single Family Res-Combo
01 111202 RK	F	Forestry	Single Family Res-Combo
03 106644 RK	R-5	Rural-5 Acre	SFR-Basic
03 106642 RK	R-5	Rural-5 Acre	SFR-Basic
03 106555 RK	R-5	Rural-5 Acre	Single Family Res-Combo
03 102916 RK	R-5	Rural-5 Acre	Single Family Res-Combo
02 109423 RK	A-10	Agriculture-10 Acre	Single Family Res-Combo
03 102147 RK	R-5	Rural-5 Acre	Accessory Apt Detached-Combo
02 109381 MH	R-5	Rural-5 Acre	Double Wide
03 105560 RK	R-9,600	Residential 9,600 sq. ft.	Duplex-Combo
03 102426 RK	R-5	Rural-5 Acre	Single Family Res-Combo
00 105651 000 01 MH	R-5	Rural-5 Acre	Single Wide
03 109310 RK	R-5	Rural-5 Acre	Single Family Res-Combo
03 103773 MH	R-5	Rural-5 Acre	Triple Wide
03 102626 MH	R-5	Rural-5 Acre	Double Wide
02 106969 RK	F	Forestry	Single Family Res-Combo
03 105882 RK	R-5	Rural-5 Acre	Single Family Res-Combo

Accessory Dwelling Units

Index # - File Name: 1.0022 - Single Family Dwellings Data\_Snohomish County.pdf

03 104869 RK	R-5	Rural-5 Acre	Single Family Res-Combo
03 101806 RK	R-5	Rural-5 Acre	Single Family Res-Combo
03 102223 MH	R-5	Rural-5 Acre	Double Wide
03 106497 RK	R-5	Rural-5 Acre	Single Family Res-Combo
03 105896 RK	R-5	Rural-5 Acre	Single Family Res-Combo
03 108793 RK	R-5	Rural-5 Acre	Single Family Res-Combo
02 110262 MH	R-7,200 : RC	Residential 7,200 sq. ft. : Ru	Triple Wide
02 108962 RK	R-5	Rural-5 Acre	Single Family Res-Combo
03 101098 RK	R-9,600	Residential 9,600 sq. ft.	Duplex-Basic
03 100769 RK	R-5	Rural-5 Acre	SFR-Basic
03 103277 RK	R-12,500	Residential 12,500 sq. ft.	Single Family Res-Combo
03 106576 RK	R-7,200	Residential 7,200 sq. ft.	Single Family Res-Combo
03 107345 RK	WFB	Waterfront Beach	Single Family Res-Combo
03 109500 RK	R-5	Rural-5 Acre	Single Family Res-Combo
03 102799 MH	F	Forestry	Double Wide
03 104007 RK	R-5	Rural-5 Acre	Single Family Res-Combo
99 104315 000 01 RK	R-9,600	Residential 9,600 sq. ft.	Single Family Res-Combo
02 109437 MH	R-5	Rural-5 Acre	Double Wide
03 102532 RK	R-9,600	Residential 9,600 sq. ft.	Single Family Res-Combo
03 102777 RK	PRD-20,000(M	Residential 20,000 sq. ft.	Single Family Res-Combo
03 102844 MH	PRD-20,000(M	Residential 20,000 sq. ft.	Double Wide
03 106091 MH	PRD-20,000(M	Residential 20,000 sq. ft.	Triple Wide
03 104432 MH	R-5	Rural-5 Acre	Double Wide
03 100218 RK	F	Forestry	Single Family Res-Combo
03 100694 RK	F	Forestry	Single Family Res-Combo
03 108369 RK	F	Forestry	Single Family Res-Combo
03 104414 RK	R-8,400	Residential 8,400 sq. ft.	Duplex-Combo
03 100893 MH	A-10	Agriculture-10 Acre	Double Wide
02 110251 RK	R-5	Rural-5 Acre	Single Family Res-Combo
03 102623 MH	R-5	Rural-5 Acre	Double Wide
03 102812 RK	R-5	Rural-5 Acre	Single Family Res-Combo
02 110060 RK	R-8,400	Residential 8,400 sq. ft.	Single Family Res-Combo
03 109290 RK	R-9,600	Residential 9,600 sq. ft.	Single Family Res-Combo
03 104462 MH	R-5	Rural-5 Acre	Single Wide
03 104569 RK	R-5	Rural-5 Acre	Single Family Res-Combo
02 110606 RK	R-5	Rural-5 Acre	Single Family Res-Combo
03 104924 RK	R-5	Rural-5 Acre	Single Family Res-Combo
03 108411 RK	R-5	Rural-5 Acre	SFR-Basic
03 105186 RK	R-7,200	Residential 7,200 sq. ft.	Single Family Res-Combo
03 107321 RK	R-5	Rural-5 Acre	Single Family Res-Combo
03 108796 RK	R-5	Rural-5 Acre	Single Family Res-Combo
03 104198 RK	R-5	Rural-5 Acre	Single Family Res-Combo
03 108910 RK	R-5	Rural-5 Acre	Single Family Res-Combo
03 108152 RK	R-5	Rural-5 Acre	Single Family Res-Combo
03 106541 RK	R-5	Rural-5 Acre	Single Family Res-Combo
03 108249 RK	R-5	Rural-5 Acre	Single Family Res-Combo
03 103762 RK	R-9,600	Residential 9,600 sq. ft.	Duplex-Combo

Accessory Dwelling Units

Index # - File Name: 1.0022 - Single Family Dwellings Data\_Snohomish County.pdf

03 101006 RK	LDMR	Low Density Multiple Reside	Single Family Res-Combo
03 100311 RK	R-5	Rural-5 Acre	Accessory Apt Detached-Combo
02 104098 MH	A-10	Agriculture-10 Acre	Double Wide
03 103408 RK	R-5	Rural-5 Acre	Single Family Res-Combo
02 110246 RK	R-5	Rural-5 Acre	Single Family Res-Combo
03 105210 RK	LDMR	Low Density Multiple Reside	Single Family Res-Combo
02 109943 RK	R-5	Rural-5 Acre	Single Family Res-Combo
03 102007 MH	R-5	Rural-5 Acre	Double Wide
03 103471 MH	F	Forestry	Double Wide
03 106763 RK	F	Forestry	Single Family Res-Combo
03 104615 RK	R-5	Rural-5 Acre	Single Family Res-Combo
03 105711 RK	F	Forestry	Single Family Res-Combo
03 104862 MH	R-5	Rural-5 Acre	Single Wide
01 105427 RK	R-8,400 : R-9,600	Residential 8,400 sq. ft. : Residential 9,600 sq. ft.	Single Family Res-Combo
01 105421 RK	R-9,600	Residential 9,600 sq. ft.	Single Family Res-Combo
01 105422 RK	R-9,600	Residential 9,600 sq. ft.	Single Family Res-Combo
03 106321 RK	R-5	Rural-5 Acre	SFR-Basic
03 106322 RK	R-5	Rural-5 Acre	SFR-Basic
03 109246 RK	RRT-10	Rural Resource Transition-10	SFR-Basic
03 107033 RK	RRT-10	Rural Resource Transition-10	Single Family Res-Combo
03 109639 RK	R-5	Rural-5 Acre	Single Family Res-Combo
03 101307 RK	R-5	Rural-5 Acre	SFR-Basic
03 101358 RK	R-5	Rural-5 Acre	Single Family Res-Combo
03 100294 RK	R-5	Rural-5 Acre	Single Family Res-Combo
03 103638 RK	R-5	Rural-5 Acre	Single Family Res-Combo
03 104234 RK	R-5	Rural-5 Acre	Single Family Res-Combo
03 106848 RK	R-5	Rural-5 Acre	Single Family Res-Combo
03 108195 RK	R-5	Rural-5 Acre	Single Family Res-Combo
99 110655 RK	R-5	Rural-5 Acre	Duplex-Combo
01 100837 000 01 RK	R-5	Rural-5 Acre	Single Family Res-Combo
03 107876 RK	R-5	Rural-5 Acre	Single Family Res-Combo
01 111219 MH	RRT-10	Rural Resource Transition-10	Triple Wide
03 103723 RK	R-5	Rural-5 Acre	Single Family Res-Combo
03 102941 RK	R-5	Rural-5 Acre	Single Family Res-Combo
03 101521 RK	R-5	Rural-5 Acre	Single Family Res-Combo
03 107697 RK	R-5	Rural-5 Acre	Single Family Res-Combo
03 107964 RK	R-5	Rural-5 Acre	Single Family Res-Combo
03 105066 RK	R-5	Rural-5 Acre	Accessory Apt Detached-Combo
03 104545 RK	PRD SA-1	Suburban Agriculture-1 Acre	SFR-Basic
02 109878 RK	R-5	Rural-5 Acre	Single Family Res-Combo
03 104523 RK	R-5	Rural-5 Acre	Single Family Res-Combo
03 104518 RK	R-5	Rural-5 Acre	Single Family Res-Combo
02 110631 RK	R-5	Rural-5 Acre	Single Family Res-Combo
03 100054 MH	R-5	Rural-5 Acre	Double Wide
03 101489 RK	R-5	Rural-5 Acre	Single Family Res-Combo
03 103578 RK	RD	Rural Diversification	Single Family Res-Combo
03 103395 RK	R-5	Rural-5 Acre	Single Family Res-Combo

Accessory Dwelling Units

Index # - File Name: 1.0022 - Single Family Dwellings Data\_Snohomish County.pdf

03 105124 RK	SA-1	Suburban Agriculture-1 Acre	Single Family Res-Combo
03 105125 RK	SA-1	Suburban Agriculture-1 Acre	Single Family Res-Combo
02 106987 RK	CITY	City	Single Family Res-Combo
03 100529 RK	R-5	Rural-5 Acre	Single Family Res-Combo
03 104900 RK	R-5	Rural-5 Acre	SFR-Basic
02 107971 RK	R-5	Rural-5 Acre	Single Family Res-Combo
03 103716 RK	R-5	Rural-5 Acre	Single Family Res-Combo
01 108063 RK	R-5	Rural-5 Acre	Single Family Res-Combo
00 106756 000 01 RK	R-5	Rural-5 Acre	Single Family Res-Combo
03 104434 RK	PRD SA-1	Suburban Agriculture-1 Acre	SFR-Basic
03 104690 RK	PRD SA-1	Suburban Agriculture-1 Acre	SFR-Basic
03 103473 RK	PRD SA-1	Suburban Agriculture-1 Acre	SFR-Basic
03 100520 RK	PRD SA-1	Suburban Agriculture-1 Acre	Single Family Res-Combo
03 103752 RK	PRD SA-1	Suburban Agriculture-1 Acre	Single Family Res-Combo
03 109205 RK	PRD SA-1	Suburban Agriculture-1 Acre	SFR-Basic
03 104689 RK	PRD SA-1	Suburban Agriculture-1 Acre	SFR-Basic
03 102732 RK	PRD SA-1	Suburban Agriculture-1 Acre	SFR-Basic
03 100636 RK	PRD SA-1	Suburban Agriculture-1 Acre	Single Family Res-Combo
03 104433 RK	PRD SA-1	Suburban Agriculture-1 Acre	SFR-Basic
02 110719 RK	R-5	Rural-5 Acre	Single Family Res-Combo
03 107874 RK	R-5	Rural-5 Acre	Single Family Res-Combo
03 106509 MH	MR	Multiple Residential	Double Wide
03 106512 MH	MR	Multiple Residential	Double Wide
03 100717 RK	R-5	Rural-5 Acre	Accessory Apt Detached-Combo
03 102138 RK	R-5	Rural-5 Acre	Single Family Res-Combo
03 102684 RK	R-5	Rural-5 Acre	Single Family Res-Combo
03 104525 RK	PRD-9,600	Residential 9,600 sq. ft.	Single Family Res-Combo
03 102072 RK	R-5	Rural-5 Acre	Single Family Res-Combo
01 105274 RK	R-5	Rural-5 Acre	Single Family Res-Combo
03 104123 MH	R-5	Rural-5 Acre	Double Wide
01 105273 RK	R-5	Rural-5 Acre	Single Family Res-Combo
03 100556 RK	R-5	Rural-5 Acre	SFR-Basic
03 109622 RK	R-5	Rural-5 Acre	SFR-Basic
03 109618 RK	R-5	Rural-5 Acre	SFR-Basic
03 109625 RK	R-5	Rural-5 Acre	SFR-Basic
01 103827 000 01 RK	PRD-9,600	Residential 9,600 sq. ft.	SFR-Basic
01 103833 000 01 RK	PRD-9,600	Residential 9,600 sq. ft.	SFR-Basic
02 110082 RK	R-5	Rural-5 Acre	Single Family Res-Combo
03 105803 RK	R-5	Rural-5 Acre	Single Family Res-Combo
01 100493 000 01 RK	PRD-9,600	Residential 9,600 sq. ft.	Single Family Res-Combo
01 100494 000 01 RK	PRD-9,600	Residential 9,600 sq. ft.	Single Family Res-Combo
03 100288 MH	RD	Rural Diversification	Double Wide
01 104942 000 01 MH	R-5	Rural-5 Acre	Double Wide
01 104945 000 01 MH	R-5	Rural-5 Acre	Double Wide
03 106207 RK	R-5	Rural-5 Acre	Single Family Res-Combo
03 101342 RK	R-5	Rural-5 Acre	Single Family Res-Combo
03 103857 RK	CITY	City	Duplex-Combo

Accessory Dwelling Units

Index # - File Name: 1.0022 - Single Family Dwellings Data\_Snohomish County.pdf

03 101605 RK	R-5	Rural-5 Acre	Single Family Res-Combo
03 106081 RK	R-5	Rural-5 Acre	Single Family Res-Combo
03 101416 RK	R-5	Rural-5 Acre	Single Family Res-Combo
03 103000 RK	R-5	Rural-5 Acre	Single Family Res-Combo
03 100894 RK	R-5	Rural-5 Acre	SFR-Basic
03 100915 RK	R-5	Rural-5 Acre	Single Family Res-Combo
03 105809 RK	R-5	Rural-5 Acre	SFR-Basic
03 107609 RK	R-5	Rural-5 Acre	Single Family Res-Combo
03 100486 RK	R-9,600	Residential 9,600 sq. ft.	Single Family Res-Combo
03 101081 RK	R-9,600	Residential 9,600 sq. ft.	Single Family Res-Combo
03 102543 RK	R-9,600	Residential 9,600 sq. ft.	SFR-Basic
03 101477 RK	R-9,600	Residential 9,600 sq. ft.	Single Family Res-Combo
03 104162 RK	R-9,600	Residential 9,600 sq. ft.	Single Family Res-Combo
03 102922 RK	R-9,600	Residential 9,600 sq. ft.	SFR-Basic
02 107116 RK	R-5	Rural-5 Acre	Single Family Res-Combo
02 110721 RK	R-5	Rural-5 Acre	Single Family Res-Combo
02 108970 RK	R-9,600	Residential 9,600 sq. ft.	SFR-Basic
02 106222 RK	R-9,600	Residential 9,600 sq. ft.	Single Family Res-Combo
03 100788 RK	R-9,600	Residential 9,600 sq. ft.	Single Family Res-Combo
03 108998 RK	R-5	Rural-5 Acre	SFR-Basic
03 108999 RK	R-5	Rural-5 Acre	SFR-Basic
03 109000 RK	R-5	Rural-5 Acre	SFR-Basic
03 102645 RK	R-5	Rural-5 Acre	Single Family Res-Combo
03 100037 RK	R-5	Rural-5 Acre	Single Family Res-Combo
02 104933 RK	R-9,600	Residential 9,600 sq. ft.	Single Family Res-Combo
03 100920 RK	R-5	Rural-5 Acre	Single Family Res-Combo
03 101102 RK	R-5	Rural-5 Acre	SFR-Basic
03 101101 RK	R-5	Rural-5 Acre	SFR-Basic
03 100211 RK	R-5	Rural-5 Acre	SFR-Basic
02 110339 RK	R-5	Rural-5 Acre	SFR-Basic
02 110380 RK	R-5	Rural-5 Acre	SFR-Basic
03 100205 RK	R-5	Rural-5 Acre	SFR-Basic
02 110605 RK	R-5	Rural-5 Acre	Single Family Res-Combo
02 110340 RK	R-5	Rural-5 Acre	Single Family Res-Combo
02 110609 RK	R-5	Rural-5 Acre	Single Family Res-Combo
02 109409 RK	R-5	Rural-5 Acre	Single Family Res-Combo
02 110186 RK	R-5	Rural-5 Acre	Single Family Res-Combo
03 100208 RK	R-5	Rural-5 Acre	SFR-Basic
03 104481 RK	R-5	Rural-5 Acre	Single Family Res-Combo
03 100031 RK	R-5	Rural-5 Acre	SFR-Basic
02 109924 MH	R-5	Rural-5 Acre	Double Wide
03 101053 RK	R-5	Rural-5 Acre	Single Family Res-Combo
02 108589 RK	R-5	Rural-5 Acre	Single Family Res-Combo
02 108801 RK	R-5	Rural-5 Acre	Single Family Res-Combo
03 105776 RK	R-5	Rural-5 Acre	Single Family Res-Combo
03 100625 RK	R-5	Rural-5 Acre	Single Family Res-Combo
03 102205 RK	PRD-7,200	Residential 7,200 sq. ft.	Single Family Res-Combo

Accessory Dwelling Units

Index # - File Name: 1.0022 - Single Family Dwellings Data\_Snohomish County.pdf

03 103900 RK	PRD-7,200	Residential 7,200 sq. ft.	SFR-Basic
03 105442 RK	PRD-7,200	Residential 7,200 sq. ft.	Single Family Res-Combo
03 103894 RK	PRD-7,200	Residential 7,200 sq. ft.	SFR-Basic
03 107738 RK	PRD-7,200	Residential 7,200 sq. ft.	Single Family Res-Combo
03 101607 RK	PRD-7,200	Residential 7,200 sq. ft.	Single Family Res-Combo
02 110601 RK	NB	Neighborhood Business	Duplex-Combo
03 107008 RK	R-5	Rural-5 Acre	Single Family Res-Combo
03 101502 RK	R-5	Rural-5 Acre	SFR-Basic
03 101601 RK	R-5	Rural-5 Acre	SFR-Basic
03 101506 RK	R-5	Rural-5 Acre	SFR-Basic
03 100350 RK	R-5	Rural-5 Acre	SFR-Basic
03 100354 RK	R-5	Rural-5 Acre	SFR-Basic
02 108982 RK	R-5	Rural-5 Acre	Single Family Res-Combo
03 100987 RK	R-5	Rural-5 Acre	SFR-Basic
03 107157 RK	R-5	Rural-5 Acre	SFR-Basic
02 110581 RK	R-5	Rural-5 Acre	SFR-Basic
03 100990 RK	R-5	Rural-5 Acre	Single Family Res-Combo
03 107306 RK	R-5	Rural-5 Acre	Single Family Res-Combo
03 107308 RK	R-5	Rural-5 Acre	SFR-Basic
03 100490 RK	R-5	Rural-5 Acre	SFR-Basic
03 107305 RK	R-5	Rural-5 Acre	Single Family Res-Combo
03 107506 RK	R-5	Rural-5 Acre	SFR-Basic
03 107507 RK	R-5	Rural-5 Acre	Single Family Res-Combo
02 110378 RK	R-5	Rural-5 Acre	SFR-Basic
02 109258 RK	R-5	Rural-5 Acre	SFR-Basic
02 110316 RK	R-5	Rural-5 Acre	SFR-Basic
02 110315 RK	R-5	Rural-5 Acre	SFR-Basic
03 100539 RK	A-10 : R-5	Agriculture-10 Acre : Rural-5	SFR-Basic
03 108706 RK	A-10 : R-5	Agriculture-10 Acre : Rural-5	SFR-Basic
02 110431 RK	R-5	Rural-5 Acre	SFR-Basic
01 101339 000 01 RK	R-5	Rural-5 Acre	Single Family Res-Combo
01 101002 000 01 RK	R-5	Rural-5 Acre	Single Family Res-Combo
03 105129 RK	R-5	Rural-5 Acre	Single Family Res-Combo
02 110662 RK	R-7,200	Residential 7,200 sq. ft.	Single Family Res-Combo
02 110103 RK	R-5	Rural-5 Acre	SFR-Basic
03 103309 RK	R-5	Rural-5 Acre	Single Family Res-Combo
03 100517 RK	R-5	Rural-5 Acre	Single Family Res-Combo
03 100001 RK	R-7,200	Residential 7,200 sq. ft.	Single Family Res-Combo
02 109608 RK	R-7,200	Residential 7,200 sq. ft.	Single Family Res-Combo
01 101582 000 01 RK	R-5	Rural-5 Acre	Single Family Res-Combo
03 105737 RK	R-7,200	Residential 7,200 sq. ft.	Single Family Res-Combo
02 104810 RK	R-5	Rural-5 Acre	Single Family Res-Combo
03 100522 RK	R-5	Rural-5 Acre	Single Family Res-Combo
03 105997 RK	R-5	Rural-5 Acre	SFR-Basic
03 103984 RK	R-5	Rural-5 Acre	Single Family Res-Combo
03 102855 RK	R-5	Rural-5 Acre	SFR-Basic
03 105995 RK	R-5	Rural-5 Acre	SFR-Basic

Accessory Dwelling Units

Index # - File Name: 1.0022 - Single Family Dwellings Data\_Snohomish County.pdf

03 103937 RK	R-5	Rural-5 Acre	Single Family Res-Combo
03 107735 RK	R-5	Rural-5 Acre	Single Family Res-Combo
03 105994 RK	R-5	Rural-5 Acre	SFR-Basic
03 110683 RK	R-5	Rural-5 Acre	Single Family Res-Combo
01 106812 000 01 RK	R-5	Rural-5 Acre	Single Family Res-Combo
02 109554 RK	R-5	Rural-5 Acre	Single Family Res-Combo
03 101063 RK	F	Forestry	Single Family Res-Combo
02 109827 RK	R-5	Rural-5 Acre	Single Family Res-Combo
02 110430 RK	R-5	Rural-5 Acre	SFR-Basic
03 101409 RK	R-5	Rural-5 Acre	SFR-Basic
03 102999 RK	R-5	Rural-5 Acre	SFR-Basic
03 102998 RK	R-5	Rural-5 Acre	SFR-Basic
02 110419 RK	R-5	Rural-5 Acre	SFR-Basic
02 110423 RK	R-5	Rural-5 Acre	SFR-Basic
03 106814 RK	R-5	Rural-5 Acre	SFR-Basic
03 106817 RK	R-5	Rural-5 Acre	SFR-Basic
03 104725 RK	R-5	Rural-5 Acre	Single Family Res-Combo
02 110206 RK	R-5	Rural-5 Acre	Single Family Res-Combo
03 100536 RK	A-10 : R-5	Agriculture-10 Acre : Rural-5	SFR-Basic
01 100495 000 01 RK	R-5	Rural-5 Acre	Single Family Res-Combo
03 105067 RK	R-5	Rural-5 Acre	Single Family Res-Combo
03 101871 RK	R-5	Rural-5 Acre	SFR-Basic
03 102163 RK	R-5	Rural-5 Acre	Single Family Res-Combo
03 106998 RK	R-5	Rural-5 Acre	Single Family Res-Combo
03 102523 RK	R-5	Rural-5 Acre	Single Family Res-Combo
03 107934 RK	R-9,600	Residential 9,600 sq. ft.	SFR-Basic
02 104293 RK	R-9,600	Residential 9,600 sq. ft.	SFR-Basic
03 109365 RK	R-9,600	Residential 9,600 sq. ft.	SFR-Basic
03 106316 RK	R-5	Rural-5 Acre	Single Family Res-Combo
03 101186 RK	R-5	Rural-5 Acre	Single Family Res-Combo
02 105814 RK	R-9,600	Residential 9,600 sq. ft.	Single Family Res-Combo
03 103545 RK	R-9,600	Residential 9,600 sq. ft.	Single Family Res-Combo
02 105818 RK	R-9,600	Residential 9,600 sq. ft.	SFR-Basic
03 108856 RK	R-9,600	Residential 9,600 sq. ft.	Single Family Res-Combo
03 102551 RK	R-9,600	Residential 9,600 sq. ft.	SFR-Basic
03 109533 RK	R-9,600	Residential 9,600 sq. ft.	SFR-Basic
03 102305 RK	R-9,600	Residential 9,600 sq. ft.	SFR-Basic
03 103981 RK	R-9,600	Residential 9,600 sq. ft.	SFR-Basic
02 104332 RK	R-9,600	Residential 9,600 sq. ft.	SFR-Basic
03 101567 RK	R-9,600	Residential 9,600 sq. ft.	SFR-Basic
03 100774 RK	R-9,600	Residential 9,600 sq. ft.	SFR-Basic
03 105419 RK	R-9,600	Residential 9,600 sq. ft.	SFR-Basic
02 105359 RK	R-9,600	Residential 9,600 sq. ft.	SFR-Basic
02 105358 RK	R-9,600	Residential 9,600 sq. ft.	SFR-Basic
03 107309 MH	A-10	Agriculture-10 Acre	Double Wide
02 109425 RK	R-5	Rural-5 Acre	Single Family Res-Combo
03 102199 RK	PRD-7,200	Residential 7,200 sq. ft.	Single Family Res-Combo

Accessory Dwelling Units

Index # - File Name: 1.0022 - Single Family Dwellings Data\_Snohomish County.pdf

02 108172 RK	RD	Rural Diversification	Single Family Res-Combo
03 104998 RK	R-9,600	Residential 9,600 sq. ft.	SFR-Basic
03 105425 MH	R-5	Rural-5 Acre	Double Wide
03 101892 RK	F	Forestry	Single Family Res-Combo
03 106421 RK	R-5	Rural-5 Acre	Single Family Res-Combo
02 109928 MH	R-5	Rural-5 Acre	Double Wide
02 107653 RK	R-5	Rural-5 Acre	Single Family Res-Combo
00 104474 000 01 RK	R-8,400	Residential 8,400 sq. ft.	Single Family Res-Combo
02 108972 RK	R-5	Rural-5 Acre	SFR-Basic
03 103962 RK	R-5	Rural-5 Acre	SFR-Basic
03 105715 RK	R-5	Rural-5 Acre	SFR-Basic
02 109925 MH	R-5	Rural-5 Acre	Double Wide
03 105212 RK	R-5	Rural-5 Acre	Single Family Res-Combo
03 100287 MH	R-5	Rural-5 Acre	Double Wide
03 108235 RK	R-5	Rural-5 Acre	Single Family Res-Combo
03 105415 RK	R-5	Rural-5 Acre	Single Family Res-Combo
03 105398 RK	R-5	Rural-5 Acre	Single Family Res-Combo
03 100541 RK	RRT-10	Rural Resource Transition-10	Single Family Res-Combo
02 110109 RK	R-9,600	Residential 9,600 sq. ft.	Single Family Res-Combo
03 101235 RK	R-5	Rural-5 Acre	Single Family Res-Combo
03 100935 RK	R-5	Rural-5 Acre	Single Family Res-Combo
00 110971 000 01 RK	R-5	Rural-5 Acre	Single Family Res-Combo
03 109046 RK	R-5	Rural-5 Acre	Single Family Res-Combo
03 106816 RK	R-5	Rural-5 Acre	Single Family Res-Combo
03 105297 RK	R-5	Rural-5 Acre	Single Family Res-Combo
03 104408 RK	R-5	Rural-5 Acre	Single Family Res-Combo
03 104795 RK	R-5	Rural-5 Acre	SFR-Basic
03 101238 RK	R-5	Rural-5 Acre	Single Family Res-Combo
03 104191 MH	RD	Rural Diversification	
03 102800 RK	CITY	City	Single Family Res-Combo
03 102937 RK	R-5	Rural-5 Acre	Single Family Res-Combo
03 108594 RK	R-5	Rural-5 Acre	Single Family Res-Combo
03 101494 RK	F	Forestry	Single Family Res-Combo
03 100606 RK	R-5	Rural-5 Acre	SFR-Basic
03 106950 RK	R-9,600	Residential 9,600 sq. ft.	Single Family Res-Combo
00 103971 000 01 RK	R-5	Rural-5 Acre	Single Family Res-Combo
03 108893 RK	R-9,600	Residential 9,600 sq. ft.	SFR-Basic
01 104393 RK	R-5	Rural-5 Acre	Single Family Res-Combo
03 102215 RK	R-5	Rural-5 Acre	Single Family Res-Combo
00 108463 000 01 RK	RD	Rural Diversification	Single Family Res-Combo
02 110295 RK	R-5	Rural-5 Acre	Single Family Res-Combo
03 102698 RK	R-5	Rural-5 Acre	Single Family Res-Combo
03 103626 RK	F	Forestry	Single Family Res-Combo
03 100028 RK	R-9,600	Residential 9,600 sq. ft.	Single Family Res-Combo
02 107987 RK	R-5	Rural-5 Acre	Single Family Res-Combo
03 102935 RK	R-5	Rural-5 Acre	Single Family Res-Combo
03 102934 RK	R-5	Rural-5 Acre	SFR-Basic



Accessory Dwelling Units

Index # - File Name: 1.0022 - Single Family Dwellings Data\_Snohomish County.pdf

03 104063 RK	R-5	Rural-5 Acre	SFR-Basic
03 108421 RK	R-5	Rural-5 Acre	Single Family Res-Combo
03 102862 RK	RRT-10	Rural Resource Transition-1(SFR-Basic	
03 106429 RK	RRT-10	Rural Resource Transition-1(SFR-Basic	
03 109548 RK	RRT-10	Rural Resource Transition-1(SFR-Basic	
03 109549 RK	RRT-10	Rural Resource Transition-1(SFR-Basic	
03 106764 RK	RRT-10	Rural Resource Transition-1(SFR-Basic	
03 102006 RK	RRT-10	Rural Resource Transition-1(Single Family Res-Combo	
03 102008 RK	RRT-10	Rural Resource Transition-1(Single Family Res-Combo	
03 109917 RK	RRT-10	Rural Resource Transition-1(Single Family Res-Combo	
03 108702 RK	R-5	Rural-5 Acre	Single Family Res-Combo
03 103939 RK	R-5	Rural-5 Acre	Single Family Res-Combo
03 105190 RK	R-5	Rural-5 Acre	Single Family Res-Combo
03 107384 RK	R-5	Rural-5 Acre	Single Family Res-Combo
03 106777 RK	R-5	Rural-5 Acre	Single Family Res-Combo
03 106780 RK	R-5	Rural-5 Acre	SFR-Basic
03 101474 RK	R-5	Rural-5 Acre	Single Family Res-Combo
03 101476 RK	R-5	Rural-5 Acre	Single Family Res-Combo
03 105926 RK	R-5	Rural-5 Acre	Single Family Res-Combo
03 103005 RK	R-5	Rural-5 Acre	Single Family Res-Combo
03 105924 RK	R-5	Rural-5 Acre	Single Family Res-Combo
03 109154 RK	R-5	Rural-5 Acre	Single Family Res-Combo
03 105146 RK	R-5	Rural-5 Acre	SFR-Basic
03 103384 RK	R-5	Rural-5 Acre	SFR-Basic
03 103352 RK	R-5	Rural-5 Acre	Single Family Res-Combo
03 105448 RK	R-5	Rural-5 Acre	Single Family Res-Combo
03 105138 RK	R-5	Rural-5 Acre	SFR-Basic
03 104660 RK	R-5	Rural-5 Acre	Single Family Res-Combo
03 102889 RK	R-5	Rural-5 Acre	Single Family Res-Combo
03 100181 RK	R-5	Rural-5 Acre	Single Family Res-Combo
03 106408 RK	CITY	City	SFR-Basic
03 106410 RK	CITY	City	SFR-Basic
03 104693 RK	CITY	City	SFR-Basic
03 104169 RK	CITY	City	Single Family Res-Combo
03 104167 RK	CITY	City	Single Family Res-Combo
03 102913 RK	CITY	City	SFR-Basic
03 102914 RK	CITY	City	SFR-Basic
03 101984 RK	CITY	City	SFR-Basic
03 100282 RK	CITY	City	Single Family Res-Combo
03 102745 RK	CITY	City	SFR-Basic
03 102746 RK	CITY	City	SFR-Basic
03 102747 RK	CITY	City	SFR-Basic
03 100981 RK	CITY	City	Single Family Res-Combo
03 100982 RK	CITY	City	Single Family Res-Combo
03 103160 RK	CITY	City	Single Family Res-Combo
03 105184 RK	CITY	City	SFR-Basic
03 102742 RK	CITY	City	SFR-Basic

Accessory Dwelling Units

Index # - File Name: 1.0022 - Single Family Dwellings Data\_Snohomish County.pdf

03 102738 RK	CITY	City	SFR-Basic
03 102737 RK	CITY	City	SFR-Basic
03 102743 RK	CITY	City	SFR-Basic
03 104317 RK	CITY	City	SFR-Basic
03 101109 RK	CITY	City	SFR-Basic
03 101108 RK	CITY	City	SFR-Basic
03 101020 RK	CITY	City	SFR-Basic
03 101401 RK	CITY	City	SFR-Basic
03 101021 RK	CITY	City	SFR-Basic
03 101402 RK	CITY	City	SFR-Basic
03 100330 RK	R-5	Rural-5 Acre	Single Family Res-Combo
03 102422 RK	PRD-7,200	Residential 7,200 sq. ft.	SFR-Basic
03 101156 RK	PRD-7,200	Residential 7,200 sq. ft.	SFR-Basic
03 101158 RK	PRD-7,200	Residential 7,200 sq. ft.	SFR-Basic
03 100873 RK	PRD-7,200	Residential 7,200 sq. ft.	Single Family Res-Combo
03 100872 RK	PRD-7,200	Residential 7,200 sq. ft.	Single Family Res-Combo
03 101157 RK	PRD-7,200	Residential 7,200 sq. ft.	SFR-Basic
03 101162 RK	PRD-7,200	Residential 7,200 sq. ft.	SFR-Basic
03 101160 RK	PRD-7,200	Residential 7,200 sq. ft.	SFR-Basic
03 100855 RK	PRD-7,200	Residential 7,200 sq. ft.	SFR-Basic
03 100854 RK	PRD-7,200	Residential 7,200 sq. ft.	SFR-Basic
03 102334 RK	CITY	City	Single Family Res-Combo
03 107908 RK	PRD-9,600	Residential 9,600 sq. ft.	SFR-Basic
03 103772 RK	RRT-10	Rural Resource Transition-1	Single Family Res-Combo
03 102864 RK	RRT-10	Rural Resource Transition-1	SFR-Basic
03 101218 RK	RRT-10	Rural Resource Transition-1	Single Family Res-Combo
03 101222 RK	RRT-10	Rural Resource Transition-1	Single Family Res-Combo
03 108917 RK	RRT-10	Rural Resource Transition-1	Single Family Res-Combo
03 104240 RK	RRT-10	Rural Resource Transition-1	Single Family Res-Combo
03 104834 RK	RRT-10	Rural Resource Transition-1	Single Family Res-Combo
03 104388 RK	RRT-10	Rural Resource Transition-1	Single Family Res-Combo
03 103465 RK	RRT-10	Rural Resource Transition-1	Single Family Res-Combo
03 106428 RK	RRT-10	Rural Resource Transition-1	SFR-Basic
03 105299 RK	RRT-10	Rural Resource Transition-1	Single Family Res-Combo
03 102863 RK	RRT-10	Rural Resource Transition-1	SFR-Basic
03 106766 RK	RRT-10	Rural Resource Transition-1	SFR-Basic
03 107905 RK	PRD-9,600	Residential 9,600 sq. ft.	SFR-Basic
03 107900 RK	PRD-9,600	Residential 9,600 sq. ft.	SFR-Basic
03 107893 RK	PRD-9,600	Residential 9,600 sq. ft.	SFR-Basic
03 107901 RK	PRD-9,600	Residential 9,600 sq. ft.	SFR-Basic
03 103878 RK	PRD-9,600	Residential 9,600 sq. ft.	SFR-Basic
03 105385 RK	PRD-9,600	Residential 9,600 sq. ft.	SFR-Basic
03 104524 RK	PRD-9,600	Residential 9,600 sq. ft.	SFR-Basic
03 105800 RK	PRD-9,600	Residential 9,600 sq. ft.	SFR-Basic
03 105801 RK	PRD-9,600	Residential 9,600 sq. ft.	SFR-Basic
03 104526 RK	PRD-9,600	Residential 9,600 sq. ft.	SFR-Basic
03 103880 RK	PRD-9,600	Residential 9,600 sq. ft.	SFR-Basic

Accessory Dwelling Units

Index # - File Name: 1.0022 - Single Family Dwellings Data\_Snohomish County.pdf

03 106431 RK	PRD-9,600	Residential 9,600 sq. ft.	SFR-Basic
03 106430 RK	PRD-9,600	Residential 9,600 sq. ft.	SFR-Basic
03 103879 RK	PRD-9,600	Residential 9,600 sq. ft.	SFR-Basic
03 103876 RK	PRD-9,600	Residential 9,600 sq. ft.	SFR-Basic
03 107029 RK	PRD-9,600	Residential 9,600 sq. ft.	SFR-Basic
03 107030 RK	PRD-9,600	Residential 9,600 sq. ft.	SFR-Basic
03 107520 RK	PRD-9,600	Residential 9,600 sq. ft.	SFR-Basic
03 107522 RK	PRD-9,600	Residential 9,600 sq. ft.	SFR-Basic
03 107894 RK	PRD-9,600	Residential 9,600 sq. ft.	SFR-Basic
03 107896 RK	PRD-9,600	Residential 9,600 sq. ft.	SFR-Basic
03 107897 RK	PRD-9,600	Residential 9,600 sq. ft.	SFR-Basic
03 105386 RK	PRD-9,600	Residential 9,600 sq. ft.	SFR-Basic
03 107895 RK	PRD-9,600	Residential 9,600 sq. ft.	SFR-Basic
03 107898 RK	PRD-9,600	Residential 9,600 sq. ft.	SFR-Basic
03 107910 RK	PRD-9,600	Residential 9,600 sq. ft.	SFR-Basic
03 100899 RK	R-8,400	Residential 8,400 sq. ft.	SFR-Basic
03 107943 RK	R-7,200	Residential 7,200 sq. ft.	SFR-Basic
03 107945 RK	R-7,200	Residential 7,200 sq. ft.	Duplex-Combo
03 104805 RK	RD	Rural Diversification	Single Family Res-Combo
03 100704 RK	R-5	Rural-5 Acre	Single Family Res-Combo
03 101103 MH	R-5	Rural-5 Acre	Double Wide
03 100820 MH	R-5	Rural-5 Acre	Double Wide
03 101622 RK	R-7,200	Residential 7,200 sq. ft.	Single Family Res-Combo
03 101623 RK	R-7,200	Residential 7,200 sq. ft.	Single Family Res-Combo
03 101619 RK	R-7,200	Residential 7,200 sq. ft.	Single Family Res-Combo
03 100080 RK	R-5	Rural-5 Acre	Single Family Res-Combo
03 101941 RK	R-5	Rural-5 Acre	Single Family Res-Combo
03 103091 RK	R-5	Rural-5 Acre	Single Family Res-Combo
02 109768 RK	R-5	Rural-5 Acre	Single Family Res-Combo
03 100283 RK	R-5	Rural-5 Acre	Single Family Res-Combo
03 100078 RK	R-5	Rural-5 Acre	Single Family Res-Combo
03 105224 RK	R-5	Rural-5 Acre	Single Family Res-Combo
03 107938 RK	R-5	Rural-5 Acre	Single Family Res-Combo
03 105228 RK	R-5	Rural-5 Acre	Single Family Res-Combo
03 100210 RK	R-7,200	Residential 7,200 sq. ft.	Single Family Res-Combo
03 111095 RK	R-7,200	Residential 7,200 sq. ft.	SFR-Basic
03 105188 RK	R-7,200	Residential 7,200 sq. ft.	SFR-Basic
03 100082 RK	R-5	Rural-5 Acre	Single Family Res-Combo
03 107461 RK	CITY	City	SFR-Basic
03 106545 RK	CITY	City	SFR-Basic
03 106547 RK	CITY	City	SFR-Basic
03 105946 RK	CITY	City	SFR-Basic
03 105732 RK	CITY	City	SFR-Basic
03 105733 RK	CITY	City	SFR-Basic
03 101520 RK	CITY	City	Single Family Res-Combo
03 103159 RK	CITY	City	SFR-Basic
03 104315 RK	CITY	City	SFR-Basic

Accessory Dwelling Units

Index # - File Name: 1.0022 - Single Family Dwellings Data\_Snohomish County.pdf

03 103388 RK	CITY	City	SFR-Basic
03 103161 RK	CITY	City	Single Family Res-Combo
03 103387 RK	CITY	City	SFR-Basic
03 104102 RK	CITY	City	SFR-Basic
03 103386 RK	CITY	City	SFR-Basic
03 104103 RK	CITY	City	SFR-Basic
03 103841 RK	CITY	City	SFR-Basic
03 103842 RK	CITY	City	SFR-Basic
03 107568 RK	CITY	City	SFR-Basic
03 107569 RK	CITY	City	SFR-Basic
03 104694 RK	CITY	City	SFR-Basic
03 107570 RK	CITY	City	SFR-Basic
03 107980 RK	CITY	City	SFR-Basic
03 107979 RK	CITY	City	SFR-Basic
03 107463 RK	CITY	City	SFR-Basic
03 107257 RK	CITY	City	SFR-Basic
03 105656 RK	CITY	City	Single Family Res-Combo
03 105266 RK	CITY	City	SFR-Basic
03 104703 RK	CITY	City	SFR-Basic
03 105267 RK	CITY	City	SFR-Basic
03 107627 RK	CITY	City	SFR-Basic
03 105709 RK	CITY	City	SFR-Basic
03 103828 RK	CITY	City	SFR-Basic
03 103497 RK	CITY	City	SFR-Basic
03 103498 RK	CITY	City	SFR-Basic
03 103496 RK	CITY	City	SFR-Basic
03 103829 RK	CITY	City	SFR-Basic
03 103499 RK	CITY	City	SFR-Basic
03 103830 RK	CITY	City	SFR-Basic
03 103500 RK	CITY	City	SFR-Basic
03 103495 RK	CITY	City	SFR-Basic
03 102707 RK	CITY	City	SFR-Basic
03 102708 RK	CITY	City	SFR-Basic
03 102709 RK	CITY	City	SFR-Basic
03 102710 RK	CITY	City	SFR-Basic
03 102711 RK	CITY	City	SFR-Basic
03 102706 RK	CITY	City	SFR-Basic
03 102380 RK	CITY	City	Single Family Res-Combo
03 103501 RK	CITY	City	SFR-Basic
02 110066 RK	R-5	Rural-5 Acre	Single Family Res-Combo
03 102704 RK	R-8,400	Residential 8,400 sq. ft.	Single Family Res-Combo
03 100648 RK	R-5	Rural-5 Acre	Single Family Res-Combo
03 108129 RK	R-7,200	Residential 7,200 sq. ft.	Single Family Res-Combo
03 105975 RK	R-7,200	Residential 7,200 sq. ft.	Single Family Res-Combo
03 100207 RK	R-7,200	Residential 7,200 sq. ft.	Single Family Res-Combo
03 109344 RK	R-7,200	Residential 7,200 sq. ft.	Single Family Res-Combo
03 111093 RK	R-7,200	Residential 7,200 sq. ft.	SFR-Basic

Accessory Dwelling Units

Index # - File Name: 1.0022 - Single Family Dwellings Data\_Snohomish County.pdf

03 100386 RK	CITY	City	Single Family Res-Combo
03 100371 RK	CITY	City	SFR-Basic
03 100378 RK	CITY	City	Single Family Res-Combo
03 100376 RK	CITY	City	Single Family Res-Combo
03 100377 RK	CITY	City	Single Family Res-Combo
03 100374 RK	CITY	City	Single Family Res-Combo
03 100379 RK	CITY	City	Single Family Res-Combo
03 100381 RK	CITY	City	Single Family Res-Combo
03 100380 RK	CITY	City	Single Family Res-Combo
03 100370 RK	CITY	City	SFR-Basic
03 100385 RK	CITY	City	Single Family Res-Combo
03 100384 RK	CITY	City	Single Family Res-Combo
03 100375 RK	CITY	City	Single Family Res-Combo
03 100372 RK	CITY	City	SFR-Basic
03 100383 RK	CITY	City	Single Family Res-Combo
03 100369 RK	CITY	City	SFR-Basic
03 100373 RK	CITY	City	SFR-Basic
02 109318 MH	R-5	Rural-5 Acre	Double Wide
02 109314 MH	R-5	Rural-5 Acre	Double Wide
03 109168 RK	R-7,200	Residential 7,200 sq. ft.	SFR-Basic
03 108126 RK	R-7,200	Residential 7,200 sq. ft.	SFR-Basic
03 104237 RK	R-7,200	Residential 7,200 sq. ft.	SFR-Basic
03 103369 RK	R-9,600	Residential 9,600 sq. ft.	SFR-Basic
02 110523 RK	LDMR	Low Density Multiple Reside	Single Family Res-Combo
03 104722 MH	R-5	Rural-5 Acre	Triple Wide
02 108739 RK	R-5	Rural-5 Acre	Single Family Res-Combo
03 104595 RK	R-5	Rural-5 Acre	SFR-Basic
02 109336 RK	R-5	Rural-5 Acre	Single Family Res-Combo
03 100033 RK	R-5	Rural-5 Acre	Single Family Res-Combo
03 101398 RK	R-5	Rural-5 Acre	Single Family Res-Combo
03 101396 RK	R-5	Rural-5 Acre	Single Family Res-Combo
02 100061 RK	R-5	Rural-5 Acre	Single Family Res-Combo
03 101582 RK	R-5	Rural-5 Acre	Single Family Res-Combo
03 101583 RK	R-5	Rural-5 Acre	Single Family Res-Combo
03 101638 RK	R-5	Rural-5 Acre	Single Family Res-Combo
03 103271 RK	R-5	Rural-5 Acre	SFR-Basic
03 104909 RK	R-5	Rural-5 Acre	SFR-Basic
03 104913 RK	R-5	Rural-5 Acre	SFR-Basic
02 108368 RK	CITY	City	Single Family Res-Combo
02 108365 RK	CITY	City	Single Family Res-Combo
03 108720 RK	CITY	City	Single Family Res-Combo
03 108719 RK	CITY	City	Single Family Res-Combo
03 103375 RK	CITY	City	Single Family Res-Combo
03 103264 RK	R-7,200	Residential 7,200 sq. ft.	Single Family Res-Combo
03 103263 RK	R-7,200	Residential 7,200 sq. ft.	Single Family Res-Combo
03 104420 RK	R-7,200	Residential 7,200 sq. ft.	SFR-Basic
03 104422 RK	R-7,200	Residential 7,200 sq. ft.	SFR-Basic

Accessory Dwelling Units

Index # - File Name: 1.0022 - Single Family Dwellings Data\_Snohomish County.pdf

03 102541 RK	R-7,200	Residential 7,200 sq. ft.	SFR-Basic
03 102542 RK	R-7,200	Residential 7,200 sq. ft.	SFR-Basic
03 102544 RK	R-7,200	Residential 7,200 sq. ft.	SFR-Basic
03 102546 RK	R-7,200	Residential 7,200 sq. ft.	SFR-Basic
03 102074 RK	R-7,200	Residential 7,200 sq. ft.	SFR-Basic
03 102075 RK	R-7,200	Residential 7,200 sq. ft.	SFR-Basic
03 102076 RK	R-7,200	Residential 7,200 sq. ft.	SFR-Basic
03 101874 RK	R-7,200	Residential 7,200 sq. ft.	SFR-Basic
03 101872 RK	R-7,200	Residential 7,200 sq. ft.	SFR-Basic
03 101873 RK	R-7,200	Residential 7,200 sq. ft.	SFR-Basic
03 101545 RK	R-7,200	Residential 7,200 sq. ft.	SFR-Basic
03 101543 RK	R-7,200	Residential 7,200 sq. ft.	SFR-Basic
03 101246 RK	R-8,400	Residential 8,400 sq. ft.	Single Family Res-Combo
03 101289 RK	RRT-10	Rural Resource Transition-10	Single Family Res-Combo
03 101542 RK	R-5	Rural-5 Acre	SFR-Basic
03 106961 RK	CITY	City	SFR-Basic
03 106963 RK	CITY	City	SFR-Basic
03 106962 RK	CITY	City	SFR-Basic
03 106041 RK	CITY	City	SFR-Basic
03 105998 RK	CITY	City	SFR-Basic
03 105999 RK	CITY	City	SFR-Basic
03 104850 RK	CITY	City	SFR-Basic
03 103487 RK	CITY	City	SFR-Basic
03 103484 RK	CITY	City	SFR-Basic
03 103486 RK	CITY	City	SFR-Basic
03 103488 RK	CITY	City	SFR-Basic
03 103480 RK	CITY	City	SFR-Basic
03 105232 RK	CITY	City	SFR-Basic
03 104847 RK	CITY	City	SFR-Basic
03 104848 RK	CITY	City	SFR-Basic
03 104849 RK	CITY	City	SFR-Basic
03 106072 RK	CITY	City	SFR-Basic
03 106073 RK	CITY	City	SFR-Basic
03 106077 RK	CITY	City	SFR-Basic
03 106964 RK	CITY	City	SFR-Basic
03 102954 RK	CITY	City	Single Family Res-Combo
03 108950 RK	CITY	City	SFR-Basic
03 108951 RK	CITY	City	SFR-Basic
03 109702 RK	CITY	City	SFR-Basic
03 109705 RK	CITY	City	SFR-Basic
03 110302 RK	CITY	City	SFR-Basic
03 110301 RK	CITY	City	SFR-Basic
03 104860 RK	CITY	City	SFR-Basic
03 104861 RK	CITY	City	SFR-Basic
03 104852 RK	CITY	City	SFR-Basic
03 104854 RK	CITY	City	SFR-Basic
03 104855 RK	CITY	City	SFR-Basic

Accessory Dwelling Units

Index # - File Name: 1.0022 - Single Family Dwellings Data\_Snohomish County.pdf

03 104857 RK	CITY	City	SFR-Basic
03 104859 RK	CITY	City	SFR-Basic
03 103479 RK	CITY	City	SFR-Basic
03 103483 RK	CITY	City	SFR-Basic
03 103481 RK	CITY	City	SFR-Basic
03 103482 RK	CITY	City	SFR-Basic
03 105423 RK	CITY	City	Single Family Res-Combo
03 106660 RK	CITY	City	SFR-Basic
03 106661 RK	CITY	City	SFR-Basic
03 106662 RK	CITY	City	SFR-Basic
03 106663 RK	CITY	City	SFR-Basic
03 106665 RK	CITY	City	SFR-Basic
03 106666 RK	CITY	City	SFR-Basic
03 106667 RK	CITY	City	SFR-Basic
03 103477 RK	CITY	City	SFR-Basic
03 105424 RK	CITY	City	Single Family Res-Combo
03 106676 RK	CITY	City	SFR-Basic
03 106677 RK	CITY	City	SFR-Basic
03 106678 RK	CITY	City	SFR-Basic
03 106679 RK	CITY	City	SFR-Basic
03 106680 RK	CITY	City	SFR-Basic
03 106681 RK	CITY	City	SFR-Basic
03 106682 RK	CITY	City	SFR-Basic
03 106669 RK	CITY	City	SFR-Basic
03 106684 RK	CITY	City	SFR-Basic
03 106685 RK	CITY	City	SFR-Basic
03 106686 RK	CITY	City	SFR-Basic
03 106687 RK	CITY	City	SFR-Basic
03 106688 RK	CITY	City	SFR-Basic
03 106689 RK	CITY	City	SFR-Basic
03 106670 RK	CITY	City	SFR-Basic
03 106672 RK	CITY	City	SFR-Basic
03 106673 RK	CITY	City	SFR-Basic
03 108135 RK	CITY	City	SFR-Basic
03 104851 RK	CITY	City	SFR-Basic
03 104858 RK	CITY	City	SFR-Basic
03 106039 RK	CITY	City	SFR-Basic
03 106146 RK	CITY	City	SFR-Basic
03 106147 RK	CITY	City	SFR-Basic
03 106149 RK	CITY	City	SFR-Basic
03 106148 RK	CITY	City	SFR-Basic
03 106150 RK	CITY	City	SFR-Basic
03 110303 RK	CITY	City	SFR-Basic
03 101336 RK	R-5	Rural-5 Acre	Single Family Res-Combo
03 101608 RK	R-5	Rural-5 Acre	SFR-Basic
03 104324 RK	R-5	Rural-5 Acre	SFR-Basic
03 107500 RK	R-5	Rural-5 Acre	SFR-Basic

Accessory Dwelling Units

Index # - File Name: 1.0022 - Single Family Dwellings Data\_Snohomish County.pdf

02 109661 RK	R-5	Rural-5 Acre	Single Family Res-Combo
03 101485 RK	R-5	Rural-5 Acre	SFR-Basic
03 100791 RK	R-5	Rural-5 Acre	Single Family Res-Combo
03 103592 RK	R-5	Rural-5 Acre	SFR-Basic
03 104322 RK	R-5	Rural-5 Acre	SFR-Basic
03 105165 RK	R-5	Rural-5 Acre	SFR-Basic
03 104323 RK	R-5	Rural-5 Acre	SFR-Basic
03 102851 RK	R-5	Rural-5 Acre	Single Family Res-Combo
03 105166 RK	R-5	Rural-5 Acre	SFR-Basic
03 105345 RK	R-5	Rural-5 Acre	Single Family Res-Combo
03 105346 RK	R-5	Rural-5 Acre	Single Family Res-Combo
03 105347 RK	R-5	Rural-5 Acre	Single Family Res-Combo
03 105163 RK	R-5	Rural-5 Acre	Single Family Res-Combo
03 105169 RK	R-5	Rural-5 Acre	SFR-Basic
03 105168 RK	R-5	Rural-5 Acre	SFR-Basic
03 105349 RK	R-5	Rural-5 Acre	SFR-Basic
03 105167 RK	R-5	Rural-5 Acre	SFR-Basic
03 105350 RK	R-5	Rural-5 Acre	SFR-Basic
03 106380 RK	R-5	Rural-5 Acre	Single Family Res-Combo
03 101331 RK	R-5	Rural-5 Acre	Single Family Res-Combo
03 104573 RK	CITY	City	Single Family Res-Combo
03 106969 RK	CITY	City	SFR-Basic
03 107808 RK	CITY	City	SFR-Basic
03 104576 RK	CITY	City	Single Family Res-Combo
03 106968 RK	CITY	City	SFR-Basic
03 101782 RK	R-5	Rural-5 Acre	Single Family Res-Combo
03 103441 RK	CITY	City	SFR-Basic
03 103442 RK	CITY	City	SFR-Basic
03 108309 RK	CITY	City	SFR-Basic
03 108310 RK	CITY	City	SFR-Basic
03 105751 RK	CITY	City	SFR-Basic
03 105753 RK	CITY	City	SFR-Basic
03 105755 RK	CITY	City	SFR-Basic
03 105967 RK	CITY	City	SFR-Basic
03 109137 RK	CITY	City	SFR-Basic
03 109136 RK	CITY	City	SFR-Basic
03 108605 RK	CITY	City	SFR-Basic
03 110868 RK	CITY	City	SFR-Basic
03 109135 RK	CITY	City	SFR-Basic
03 109134 RK	CITY	City	SFR-Basic
03 108311 RK	CITY	City	SFR-Basic
03 104884 RK	CITY	City	SFR-Basic
03 106949 RK	CITY	City	SFR-Basic
03 104880 RK	CITY	City	SFR-Basic
03 104417 RK	CITY	City	SFR-Basic
03 110685 RK	CITY	City	SFR-Basic
03 104882 RK	CITY	City	Single Family Res-Combo



Accessory Dwelling Units

Index # - File Name: 1.0022 - Single Family Dwellings Data\_Snohomish County.pdf

03 104677 RK	CITY	City	SFR-Basic
03 104600 RK	CITY	City	SFR-Basic
03 106605 RK	CITY	City	SFR-Basic
03 106711 RK	CITY	City	SFR-Basic
03 106710 RK	CITY	City	SFR-Basic
03 106611 RK	CITY	City	SFR-Basic
03 106606 RK	CITY	City	SFR-Basic
03 108604 RK	CITY	City	SFR-Basic
03 104704 RK	CITY	City	SFR-Basic
03 105707 RK	CITY	City	SFR-Basic
03 105947 RK	CITY	City	SFR-Basic
03 108068 RK	CITY	City	SFR-Basic
03 108069 RK	CITY	City	SFR-Basic
03 108070 RK	CITY	City	SFR-Basic
03 101444 RK	R-5	Rural-5 Acre	SFR-Basic
03 102086 MH	R-5	Rural-5 Acre	Double Wide
03 105455 RK	R-5	Rural-5 Acre	Single Family Res-Combo
03 102149 MH	R-5	Rural-5 Acre	Triple Wide
03 102153 RK	R-5	Rural-5 Acre	Single Family Res-Combo
03 102210 RK	R-5	Rural-5 Acre	Single Family Res-Combo
03 102236 RK	R-5	Rural-5 Acre	Single Family Res-Combo
03 105504 RK	R-9,600	Residential 9,600 sq. ft.	Single Family Res-Combo
03 105024 RK	R-9,600	Residential 9,600 sq. ft.	Single Family Res-Combo
03 105027 RK	R-9,600	Residential 9,600 sq. ft.	Single Family Res-Combo
03 105746 RK	R-9,600	Residential 9,600 sq. ft.	Single Family Res-Combo
03 105035 RK	R-9,600	Residential 9,600 sq. ft.	Single Family Res-Combo
03 105030 RK	R-9,600	Residential 9,600 sq. ft.	Single Family Res-Combo
03 100801 RK	R-9,600	Residential 9,600 sq. ft.	Single Family Res-Combo
03 100810 RK	R-9,600	Residential 9,600 sq. ft.	Single Family Res-Combo
03 104467 RK	R-9,600	Residential 9,600 sq. ft.	Single Family Res-Combo
03 101907 RK	R-9,600	Residential 9,600 sq. ft.	Single Family Res-Combo
03 104472 RK	R-9,600	Residential 9,600 sq. ft.	Single Family Res-Combo
03 104473 RK	R-9,600	Residential 9,600 sq. ft.	Single Family Res-Combo
03 105032 RK	R-9,600	Residential 9,600 sq. ft.	Single Family Res-Combo
03 105029 RK	R-9,600	Residential 9,600 sq. ft.	Single Family Res-Combo
03 107704 RK	R-9,600	Residential 9,600 sq. ft.	Single Family Res-Combo
03 107705 RK	R-9,600	Residential 9,600 sq. ft.	Single Family Res-Combo
03 107708 RK	R-9,600	Residential 9,600 sq. ft.	Single Family Res-Combo
03 107706 RK	R-9,600	Residential 9,600 sq. ft.	Single Family Res-Combo
03 107707 RK	R-9,600	Residential 9,600 sq. ft.	Single Family Res-Combo
03 107709 RK	R-9,600	Residential 9,600 sq. ft.	Single Family Res-Combo
03 106991 RK	R-9,600	Residential 9,600 sq. ft.	Single Family Res-Combo
03 106987 RK	R-9,600	Residential 9,600 sq. ft.	Single Family Res-Combo
03 106988 RK	R-9,600	Residential 9,600 sq. ft.	Single Family Res-Combo
03 106985 RK	R-9,600	Residential 9,600 sq. ft.	Single Family Res-Combo
03 105989 RK	PRD-7,200	Residential 7,200 sq. ft.	SFR-Basic
03 105132 RK	PRD-7,200	Residential 7,200 sq. ft.	SFR-Basic

Accessory Dwelling Units

Index # - File Name: 1.0022 - Single Family Dwellings Data\_Snohomish County.pdf

03 105133 RK	PRD-7,200	Residential 7,200 sq. ft.	SFR-Basic
03 102661 RK	PRD-7,200	Residential 7,200 sq. ft.	Single Family Res-Combo
03 105274 RK	PRD-7,200	Residential 7,200 sq. ft.	SFR-Basic
03 102945 RK	PRD-7,200	Residential 7,200 sq. ft.	SFR-Basic
03 102947 RK	PRD-7,200	Residential 7,200 sq. ft.	SFR-Basic
03 105988 RK	PRD-7,200	Residential 7,200 sq. ft.	SFR-Basic
03 103401 RK	PRD-7,200	Residential 7,200 sq. ft.	Single Family Res-Combo
03 103634 RK	PRD-7,200	Residential 7,200 sq. ft.	SFR-Basic
03 102946 RK	PRD-7,200	Residential 7,200 sq. ft.	SFR-Basic
03 103020 RK	PRD-7,200	Residential 7,200 sq. ft.	Single Family Res-Combo
03 103635 RK	PRD-7,200	Residential 7,200 sq. ft.	Single Family Res-Combo
03 102660 RK	PRD-7,200	Residential 7,200 sq. ft.	Single Family Res-Combo
03 102943 RK	PRD-7,200	Residential 7,200 sq. ft.	SFR-Basic
03 103019 RK	PRD-7,200	Residential 7,200 sq. ft.	SFR-Basic
03 104627 RK	LDMR : PRD-7,	Low Density Multiple Reside	SFR-Basic
02 108474 MH	R-5	Rural-5 Acre	Double Wide
02 108472 MH	R-5	Rural-5 Acre	Double Wide
03 100295 RK	R-5	Rural-5 Acre	Single Family Res-Combo
02 108054 RK	NB	Neighborhood Business	Duplex-Combo
02 108411 RK	CITY	City	Single Family Res-Combo
03 108823 RK	CITY	City	SFR-Basic
03 105363 RK	CITY	City	Single Family Res-Combo
03 106643 RK	CITY	City	SFR-Basic
03 106641 RK	CITY	City	SFR-Basic
03 106647 RK	CITY	City	SFR-Basic
03 106645 RK	CITY	City	SFR-Basic
03 105366 RK	CITY	City	Single Family Res-Combo
03 101350 RK	R-8,400	Residential 8,400 sq. ft.	SFR-Basic
03 101351 RK	R-8,400	Residential 8,400 sq. ft.	SFR-Basic
03 100206 RK	R-8,400	Residential 8,400 sq. ft.	SFR-Basic
03 100833 RK	PRD-9,600	Residential 9,600 sq. ft.	SFR-Basic
02 110116 RK	PRD-9,600	Residential 9,600 sq. ft.	Single Family Res-Combo
02 109430 RK	PRD-9,600	Residential 9,600 sq. ft.	Single Family Res-Combo
02 110210 RK	PRD-9,600	Residential 9,600 sq. ft.	Single Family Res-Combo
02 110009 RK	R-8,400	Residential 8,400 sq. ft.	Single Family Res-Combo
03 101165 RK	PRD-9,600	Residential 9,600 sq. ft.	SFR-Basic
03 100270 RK	PRD-9,600	Residential 9,600 sq. ft.	SFR-Basic
03 100269 RK	PRD-9,600	Residential 9,600 sq. ft.	SFR-Basic
03 101166 RK	PRD-9,600	Residential 9,600 sq. ft.	SFR-Basic
03 101167 RK	PRD-9,600	Residential 9,600 sq. ft.	SFR-Basic
03 109514 RK	CITY	City	SFR-Basic
02 108191 RK	R-5	Rural-5 Acre	Single Family Res-Combo
02 108193 RK	R-5	Rural-5 Acre	Single Family Res-Combo
02 108195 RK	R-5	Rural-5 Acre	Single Family Res-Combo
03 101068 RK	PRD-9,600	Residential 9,600 sq. ft.	SFR-Basic
03 108063 RK	PRD-9,600	Residential 9,600 sq. ft.	SFR-Basic
03 108064 RK	PRD-9,600	Residential 9,600 sq. ft.	SFR-Basic

Accessory Dwelling Units

Index # - File Name: 1.0022 - Single Family Dwellings Data\_Snohomish County.pdf

03 108065 RK	PRD-9,600	Residential 9,600 sq. ft.	SFR-Basic
03 108066 RK	PRD-9,600	Residential 9,600 sq. ft.	SFR-Basic
03 108067 RK	PRD-9,600	Residential 9,600 sq. ft.	SFR-Basic
03 109465 RK	PRD-9,600	Residential 9,600 sq. ft.	SFR-Basic
03 104105 RK	PRD-9,600	Residential 9,600 sq. ft.	SFR-Basic
03 103865 RK	PRD-9,600	Residential 9,600 sq. ft.	SFR-Basic
03 103866 RK	PRD-9,600	Residential 9,600 sq. ft.	SFR-Basic
03 103868 RK	PRD-9,600	Residential 9,600 sq. ft.	SFR-Basic
03 103649 RK	PRD-9,600	Residential 9,600 sq. ft.	SFR-Basic
03 103648 RK	PRD-9,600	Residential 9,600 sq. ft.	SFR-Basic
03 100058 RK	PRD-9,600	Residential 9,600 sq. ft.	SFR-Basic
03 100059 RK	PRD-9,600	Residential 9,600 sq. ft.	SFR-Basic
03 100060 RK	PRD-9,600	Residential 9,600 sq. ft.	SFR-Basic
03 106698 RK	PRD-9,600	Residential 9,600 sq. ft.	SFR-Basic
03 106604 RK	PRD-9,600	Residential 9,600 sq. ft.	SFR-Basic
03 106700 RK	PRD-9,600	Residential 9,600 sq. ft.	SFR-Basic
03 106704 RK	PRD-9,600	Residential 9,600 sq. ft.	SFR-Basic
03 105142 RK	PRD-9,600	Residential 9,600 sq. ft.	Single Family Res-Combo
03 104104 RK	PRD-9,600	Residential 9,600 sq. ft.	SFR-Basic
03 109313 RK	PRD-9,600	Residential 9,600 sq. ft.	SFR-Basic
03 110687 RK	PRD-9,600	Residential 9,600 sq. ft.	SFR-Basic
03 104889 RK	PRD-9,600	Residential 9,600 sq. ft.	SFR-Basic
03 103642 RK	PRD-9,600	Residential 9,600 sq. ft.	SFR-Basic
03 109623 RK	PRD-9,600	Residential 9,600 sq. ft.	SFR-Basic
03 107842 RK	PRD-9,600	Residential 9,600 sq. ft.	SFR-Basic
03 107843 RK	PRD-9,600	Residential 9,600 sq. ft.	SFR-Basic
02 107021 RK	R-5	Rural-5 Acre	Single Family Res-Combo
03 107846 RK	PRD-9,600	Residential 9,600 sq. ft.	SFR-Basic
03 100056 RK	PRD-9,600	Residential 9,600 sq. ft.	SFR-Basic
03 109314 RK	PRD-9,600	Residential 9,600 sq. ft.	SFR-Basic
03 107849 RK	PRD-9,600	Residential 9,600 sq. ft.	SFR-Basic
03 100652 RK	PRD-9,600	Residential 9,600 sq. ft.	SFR-Basic
02 107657 RK	R-5	Rural-5 Acre	Single Family Res-Combo
03 100057 RK	PRD-9,600	Residential 9,600 sq. ft.	SFR-Basic
02 110317 RK	R-5	Rural-5 Acre	Single Family Res-Combo
03 101968 RK	R-5	Rural-5 Acre	SFR-Basic
03 101967 RK	R-5	Rural-5 Acre	SFR-Basic
03 100308 RK	PRD-9,600	Residential 9,600 sq. ft.	SFR-Basic
03 100307 RK	PRD-9,600	Residential 9,600 sq. ft.	SFR-Basic
03 100306 RK	PRD-9,600	Residential 9,600 sq. ft.	SFR-Basic
03 100304 RK	PRD-9,600	Residential 9,600 sq. ft.	SFR-Basic
03 100303 RK	PRD-9,600	Residential 9,600 sq. ft.	SFR-Basic
03 100651 RK	PRD-9,600	Residential 9,600 sq. ft.	SFR-Basic
03 101065 RK	PRD-9,600	Residential 9,600 sq. ft.	SFR-Basic
03 101066 RK	PRD-9,600	Residential 9,600 sq. ft.	SFR-Basic
03 101067 RK	PRD-9,600	Residential 9,600 sq. ft.	SFR-Basic
03 100818 RK	PRD-9,600	Residential 9,600 sq. ft.	SFR-Basic

Accessory Dwelling Units

Index # - File Name: 1.0022 - Single Family Dwellings Data\_Snohomish County.pdf

03 100819 RK	PRD-9,600	Residential 9,600 sq. ft.	SFR-Basic
03 100821 RK	PRD-9,600	Residential 9,600 sq. ft.	SFR-Basic
02 110120 RK	R-5	Rural-5 Acre	Single Family Res-Combo
02 110755 RK	CITY	City	SFR-Basic
02 110754 RK	CITY	City	SFR-Basic
02 110778 RK	CITY	City	SFR-Basic
02 110765 RK	CITY	City	SFR-Basic
02 110779 RK	CITY	City	SFR-Basic
02 110766 RK	CITY	City	SFR-Basic
02 110780 RK	CITY	City	SFR-Basic
02 110767 RK	CITY	City	SFR-Basic
02 110781 RK	CITY	City	SFR-Basic
02 110768 RK	CITY	City	SFR-Basic
02 110769 RK	CITY	City	SFR-Basic
02 110756 RK	CITY	City	SFR-Basic
02 110782 RK	CITY	City	SFR-Basic
02 110770 RK	CITY	City	SFR-Basic
02 110783 RK	CITY	City	SFR-Basic
02 110757 RK	CITY	City	SFR-Basic
02 110771 RK	CITY	City	SFR-Basic
02 110758 RK	CITY	City	SFR-Basic
02 110784 RK	CITY	City	SFR-Basic
02 110772 RK	CITY	City	SFR-Basic
02 110759 RK	CITY	City	SFR-Basic
02 110726 RK	CITY	City	Single Family Res-Combo
02 110728 RK	CITY	City	Single Family Res-Combo
02 110751 RK	CITY	City	Single Family Res-Combo
02 110743 RK	CITY	City	Single Family Res-Combo
02 110744 RK	CITY	City	Single Family Res-Combo
02 110745 RK	CITY	City	Single Family Res-Combo
02 110746 RK	CITY	City	Single Family Res-Combo
02 110747 RK	CITY	City	Single Family Res-Combo
02 110748 RK	CITY	City	Single Family Res-Combo
02 110749 RK	CITY	City	Single Family Res-Combo
02 110752 RK	CITY	City	Single Family Res-Combo
02 110753 RK	CITY	City	Single Family Res-Combo
02 110733 RK	CITY	City	Single Family Res-Combo
02 110734 RK	CITY	City	Single Family Res-Combo
02 110729 RK	CITY	City	Single Family Res-Combo
02 110740 RK	CITY	City	Single Family Res-Combo
02 110735 RK	CITY	City	Single Family Res-Combo
02 110760 RK	CITY	City	SFR-Basic
02 110731 RK	CITY	City	Single Family Res-Combo
02 110736 RK	CITY	City	Single Family Res-Combo
02 110741 RK	CITY	City	Single Family Res-Combo
02 110738 RK	CITY	City	SFR-Basic
02 110739 RK	CITY	City	SFR-Basic

Accessory Dwelling Units

Index # - File Name: 1.0022 - Single Family Dwellings Data\_Snohomish County.pdf

02 110773 RK	CITY	City	SFR-Basic
02 110761 RK	CITY	City	SFR-Basic
02 110774 RK	CITY	City	SFR-Basic
02 110762 RK	CITY	City	SFR-Basic
02 110775 RK	CITY	City	SFR-Basic
02 110763 RK	CITY	City	SFR-Basic
02 110776 RK	CITY	City	SFR-Basic
02 110732 RK	CITY	City	Single Family Res-Combo
02 110764 RK	CITY	City	SFR-Basic
02 110225 MH	R-5	Rural-5 Acre	Double Wide
03 101628 RK	R-5	Rural-5 Acre	Single Family Res-Combo
03 101630 RK	R-5	Rural-5 Acre	Single Family Res-Combo
03 100190 RK	PRD-9,600	Residential 9,600 sq. ft.	SFR-Basic
03 100192 RK	PRD-9,600	Residential 9,600 sq. ft.	SFR-Basic
03 100193 RK	PRD-9,600	Residential 9,600 sq. ft.	SFR-Basic
03 100191 RK	PRD-9,600	Residential 9,600 sq. ft.	SFR-Basic
03 100194 RK	PRD-9,600	Residential 9,600 sq. ft.	SFR-Basic
03 102529 RK	PRD-9,600	Residential 9,600 sq. ft.	SFR-Basic
03 100551 RK	PRD-9,600	Residential 9,600 sq. ft.	Single Family Res-Combo
03 102530 RK	PRD-9,600	Residential 9,600 sq. ft.	SFR-Basic
03 101163 RK	PRD-9,600	Residential 9,600 sq. ft.	Single Family Res-Combo
03 106797 RK	R-5	Rural-5 Acre	Single Family Res-Combo
03 107567 RK	PRD-9,600	Residential 9,600 sq. ft.	Single Family Res-Combo
02 110390 RK	PRD-9,600	Residential 9,600 sq. ft.	Single Family Res-Combo
02 110388 RK	PRD-9,600	Residential 9,600 sq. ft.	Single Family Res-Combo
02 110389 RK	PRD-9,600	Residential 9,600 sq. ft.	Single Family Res-Combo
03 104437 RK	PRD-9,600	Residential 9,600 sq. ft.	SFR-Basic
03 104436 RK	PRD-9,600	Residential 9,600 sq. ft.	SFR-Basic
03 101457 RK	PRD-9,600	Residential 9,600 sq. ft.	SFR-Basic
02 110387 RK	PRD-9,600	Residential 9,600 sq. ft.	Single Family Res-Combo
03 101452 RK	PRD-9,600	Residential 9,600 sq. ft.	SFR-Basic
03 101143 RK	R-9,600(PRD)	Residential 9,600 sq. ft.	SFR-Basic
03 101147 RK	R-9,600(PRD)	Residential 9,600 sq. ft.	SFR-Basic
03 101146 RK	R-9,600(PRD)	Residential 9,600 sq. ft.	SFR-Basic
03 104671 RK	R-9,600(PRD)	Residential 9,600 sq. ft.	SFR-Basic
03 104586 RK	R-9,600(PRD)	Residential 9,600 sq. ft.	SFR-Basic
03 101145 RK	R-9,600(PRD)	Residential 9,600 sq. ft.	SFR-Basic
03 101422 RK	R-9,600(PRD)	Residential 9,600 sq. ft.	SFR-Basic
03 100744 RK	R-9,600(PRD)	Residential 9,600 sq. ft.	SFR-Basic
03 100741 RK	R-9,600(PRD)	Residential 9,600 sq. ft.	SFR-Basic
03 100580 RK	R-9,600(PRD)	Residential 9,600 sq. ft.	SFR-Basic
03 104670 RK	R-9,600(PRD)	Residential 9,600 sq. ft.	SFR-Basic
03 106598 RK	R-9,600(PRD)	Residential 9,600 sq. ft.	SFR-Basic
03 100908 RK	R-9,600(PRD)	Residential 9,600 sq. ft.	Single Family Res-Combo
03 104585 RK	R-9,600(PRD)	Residential 9,600 sq. ft.	SFR-Basic
03 106593 RK	R-9,600(PRD)	Residential 9,600 sq. ft.	SFR-Basic
03 100909 RK	R-9,600(PRD)	Residential 9,600 sq. ft.	SFR-Basic

Accessory Dwelling Units

Index # - File Name: 1.0022 - Single Family Dwellings Data\_Snohomish County.pdf

03 100910 RK	R-9,600(PRD)	Residential 9,600 sq. ft.	SFR-Basic
03 104584 RK	R-9,600(PRD)	Residential 9,600 sq. ft.	SFR-Basic
03 104583 RK	R-9,600(PRD)	Residential 9,600 sq. ft.	SFR-Basic
03 106340 RK	R-9,600(PRD)	Residential 9,600 sq. ft.	SFR-Basic
03 106338 RK	R-9,600(PRD)	Residential 9,600 sq. ft.	SFR-Basic
03 106584 RK	R-9,600(PRD)	Residential 9,600 sq. ft.	SFR-Basic
03 106585 RK	R-9,600(PRD)	Residential 9,600 sq. ft.	SFR-Basic
03 104582 RK	R-9,600(PRD)	Residential 9,600 sq. ft.	SFR-Basic
03 106595 RK	R-9,600(PRD)	Residential 9,600 sq. ft.	SFR-Basic
03 106596 RK	R-9,600(PRD)	Residential 9,600 sq. ft.	SFR-Basic
03 104580 RK	R-9,600(PRD)	Residential 9,600 sq. ft.	SFR-Basic
03 100911 RK	R-9,600(PRD)	Residential 9,600 sq. ft.	SFR-Basic
03 100912 RK	R-9,600(PRD)	Residential 9,600 sq. ft.	SFR-Basic
03 106597 RK	R-9,600(PRD)	Residential 9,600 sq. ft.	SFR-Basic
03 106589 RK	R-9,600(PRD)	Residential 9,600 sq. ft.	SFR-Basic
03 106591 RK	R-9,600(PRD)	Residential 9,600 sq. ft.	SFR-Basic
03 106592 RK	R-9,600(PRD)	Residential 9,600 sq. ft.	SFR-Basic
02 109337 RK	R-9,600(PRD)	Residential 9,600 sq. ft.	Single Family Res-Combo
02 109325 RK	R-9,600(PRD)	Residential 9,600 sq. ft.	Single Family Res-Combo
02 109341 RK	R-9,600(PRD)	Residential 9,600 sq. ft.	Single Family Res-Combo
03 100578 RK	R-9,600(PRD)	Residential 9,600 sq. ft.	SFR-Basic
03 102157 RK	R-9,600(PRD)	Residential 9,600 sq. ft.	SFR-Basic
03 102158 RK	R-9,600(PRD)	Residential 9,600 sq. ft.	SFR-Basic
03 105895 RK	R-9,600(PRD)	Residential 9,600 sq. ft.	SFR-Basic
03 106588 RK	R-9,600(PRD)	Residential 9,600 sq. ft.	SFR-Basic
03 102161 RK	R-9,600(PRD)	Residential 9,600 sq. ft.	SFR-Basic
03 102162 RK	R-9,600(PRD)	Residential 9,600 sq. ft.	SFR-Basic
03 100458 RK	R-9,600(PRD)	Residential 9,600 sq. ft.	SFR-Basic
03 100457 RK	R-9,600(PRD)	Residential 9,600 sq. ft.	SFR-Basic
02 109339 RK	R-9,600(PRD)	Residential 9,600 sq. ft.	Single Family Res-Combo
02 109342 RK	R-9,600(PRD)	Residential 9,600 sq. ft.	Single Family Res-Combo
03 100454 RK	R-9,600(PRD)	Residential 9,600 sq. ft.	SFR-Basic
03 100459 RK	R-9,600(PRD)	Residential 9,600 sq. ft.	SFR-Basic
03 100453 RK	R-9,600(PRD)	Residential 9,600 sq. ft.	SFR-Basic
02 105695 RK	MR	Multiple Residential	SFR-Basic
02 105682 RK	MR	Multiple Residential	SFR-Basic
02 105683 RK	MR	Multiple Residential	SFR-Basic
02 105696 RK	MR	Multiple Residential	SFR-Basic
02 105674 RK	MR	Multiple Residential	SFR-Basic
02 105689 RK	MR	Multiple Residential	SFR-Basic
02 105697 RK	MR	Multiple Residential	SFR-Basic
02 105680 RK	MR	Multiple Residential	SFR-Basic
02 105675 RK	MR	Multiple Residential	SFR-Basic
02 105698 RK	MR	Multiple Residential	SFR-Basic
02 105699 RK	MR	Multiple Residential	SFR-Basic
02 105690 RK	MR	Multiple Residential	SFR-Basic
02 105676 RK	MR	Multiple Residential	SFR-Basic

Accessory Dwelling Units

Index # - File Name: 1.0022 - Single Family Dwellings Data\_Snohomish County.pdf

02 105700 RK	MR	Multiple Residential	SFR-Basic
02 105677 RK	MR	Multiple Residential	SFR-Basic
02 105688 RK	MR	Multiple Residential	SFR-Basic
02 105687 RK	MR	Multiple Residential	SFR-Basic
02 105694 RK	MR	Multiple Residential	SFR-Basic
02 105701 RK	MR	Multiple Residential	SFR-Basic
02 105693 RK	MR	Multiple Residential	SFR-Basic
02 105686 RK	MR	Multiple Residential	SFR-Basic
02 105684 RK	MR	Multiple Residential	SFR-Basic
02 105685 RK	MR	Multiple Residential	SFR-Basic
02 105691 RK	MR	Multiple Residential	SFR-Basic
02 105678 RK	MR	Multiple Residential	SFR-Basic
02 105692 RK	MR	Multiple Residential	SFR-Basic
02 105679 RK	MR	Multiple Residential	SFR-Basic
03 110431 RK	R-5	Rural-5 Acre	SFR-Basic
03 100555 RK	R-5	Rural-5 Acre	Duplex-Combo
02 110220 RK	R-5	Rural-5 Acre	Single Family Res-Combo
02 110215 RK	R-5	Rural-5 Acre	Single Family Res-Combo
03 102869 RK	R-5	Rural-5 Acre	SFR-Basic
03 110429 RK	R-5	Rural-5 Acre	SFR-Basic
03 102870 RK	R-5	Rural-5 Acre	SFR-Basic
02 110583 RK	R-5	Rural-5 Acre	SFR-Basic
02 110584 RK	R-5	Rural-5 Acre	SFR-Basic
02 110585 RK	R-5	Rural-5 Acre	SFR-Basic
02 110586 RK	R-5	Rural-5 Acre	SFR-Basic
03 102095 RK	CITY	City	SFR-Basic
02 107334 MH	A-10	Agriculture-10 Acre	Double Wide
02 107366 RK	R-5	Rural-5 Acre	Single Family Res-Combo
03 104172 RK	CITY	City	SFR-Basic
03 104098 RK	R-5	Rural-5 Acre	SFR-Basic
03 102329 RK	R-5	Rural-5 Acre	SFR-Basic
03 101896 RK	R-5	Rural-5 Acre	Single Family Res-Combo
02 110217 RK	R-5	Rural-5 Acre	Single Family Res-Combo
02 110218 RK	R-5	Rural-5 Acre	Single Family Res-Combo
03 101436 RK	R-5	Rural-5 Acre	SFR-Basic
03 101306 RK	R-5	Rural-5 Acre	SFR-Basic
03 101635 RK	R-5	Rural-5 Acre	Single Family Res-Combo
03 101637 RK	R-5	Rural-5 Acre	SFR-Basic
03 104170 RK	CITY	City	SFR-Basic
03 102116 RK	CITY	City	SFR-Basic
02 110038 RK	A-10	Agriculture-10 Acre	Single Family Res-Combo
03 102229 RK	R-5	Rural-5 Acre	Single Family Res-Combo
02 110805 RK	PRD-7,200	Residential 7,200 sq. ft.	SFR-Basic
03 100890 RK	PRD-7,200	Residential 7,200 sq. ft.	SFR-Basic
03 100885 RK	PRD-7,200	Residential 7,200 sq. ft.	SFR-Basic
03 100825 RK	PRD-7,200	Residential 7,200 sq. ft.	SFR-Basic
03 106097 RK	PRD-7,200	Residential 7,200 sq. ft.	Single Family Res-Combo

Accessory Dwelling Units

Index # - File Name: 1.0022 - Single Family Dwellings Data\_Snohomish County.pdf

02 107035 RK	R-5 : R-7,200	Residential 7,200 sq. ft. : Ru	Single Family Res-Combo
02 110616 RK	PRD-9,600	Residential 9,600 sq. ft.	SFR-Basic
03 100528 RK	PRD-9,600	Residential 9,600 sq. ft.	SFR-Basic
03 103845 RK	PRD-9,600	Residential 9,600 sq. ft.	SFR-Basic
03 103847 RK	PRD-9,600	Residential 9,600 sq. ft.	SFR-Basic
03 105060 RK	PRD-9,600	Residential 9,600 sq. ft.	Single Family Res-Combo
03 100487 RK	PRD-9,600	Residential 9,600 sq. ft.	SFR-Basic
03 100491 RK	PRD-9,600	Residential 9,600 sq. ft.	SFR-Basic
03 105925 RK	PRD-9,600	Residential 9,600 sq. ft.	SFR-Basic
03 102164 RK	R-9,600	Residential 9,600 sq. ft.	Single Family Res-Combo
03 102165 RK	R-9,600	Residential 9,600 sq. ft.	Single Family Res-Combo
03 102166 RK	R-9,600	Residential 9,600 sq. ft.	Single Family Res-Combo
03 102167 RK	R-9,600	Residential 9,600 sq. ft.	Single Family Res-Combo
03 103366 RK	R-9,600	Residential 9,600 sq. ft.	SFR-Basic
03 103371 RK	R-9,600	Residential 9,600 sq. ft.	SFR-Basic
03 103370 RK	R-9,600	Residential 9,600 sq. ft.	SFR-Basic
03 102676 RK	R-9,600	Residential 9,600 sq. ft.	Single Family Res-Combo
03 100229 RK	CITY	City	SFR-Basic
03 100223 RK	CITY	City	SFR-Basic
02 110803 RK	PRD-7,200	Residential 7,200 sq. ft.	SFR-Basic
03 100884 RK	PRD-7,200	Residential 7,200 sq. ft.	SFR-Basic
03 103848 RK	PRD-7,200	Residential 7,200 sq. ft.	SFR-Basic
03 105871 RK	PRD-7,200	Residential 7,200 sq. ft.	SFR-Basic
03 105872 RK	PRD-7,200	Residential 7,200 sq. ft.	SFR-Basic
03 105873 RK	PRD-7,200	Residential 7,200 sq. ft.	SFR-Basic
03 105874 RK	PRD-7,200	Residential 7,200 sq. ft.	SFR-Basic
03 105681 RK	PRD-7,200	Residential 7,200 sq. ft.	SFR-Basic
03 105875 RK	PRD-7,200	Residential 7,200 sq. ft.	SFR-Basic
03 105410 RK	PRD-7,200	Residential 7,200 sq. ft.	SFR-Basic
03 105408 RK	PRD-7,200	Residential 7,200 sq. ft.	SFR-Basic
03 105409 RK	PRD-7,200	Residential 7,200 sq. ft.	SFR-Basic
03 101518 RK	PRD-7,200	Residential 7,200 sq. ft.	SFR-Basic
03 101519 RK	PRD-7,200	Residential 7,200 sq. ft.	SFR-Basic
03 103747 RK	PRD-7,200	Residential 7,200 sq. ft.	SFR-Basic
03 103749 RK	PRD-7,200	Residential 7,200 sq. ft.	SFR-Basic
03 105411 RK	PRD-7,200	Residential 7,200 sq. ft.	SFR-Basic
03 101517 RK	PRD-7,200	Residential 7,200 sq. ft.	SFR-Basic
03 100889 RK	PRD-7,200	Residential 7,200 sq. ft.	SFR-Basic
03 100887 RK	PRD-7,200	Residential 7,200 sq. ft.	SFR-Basic
03 103746 RK	PRD-7,200	Residential 7,200 sq. ft.	SFR-Basic
03 103748 RK	PRD-7,200	Residential 7,200 sq. ft.	SFR-Basic
03 101516 RK	PRD-7,200	Residential 7,200 sq. ft.	SFR-Basic
02 110802 RK	PRD-7,200	Residential 7,200 sq. ft.	SFR-Basic
03 108188 RK	R-5	Rural-5 Acre	Single Family Res-Combo
03 101536 RK	R-5	Rural-5 Acre	Single Family Res-Combo
03 101541 RK	R-5	Rural-5 Acre	Single Family Res-Combo
02 109906 MH	R-5	Rural-5 Acre	Double Wide



Accessory Dwelling Units

Index # - File Name: 1.0022 - Single Family Dwellings Data\_Snohomish County.pdf

03 102061 RK	R-5	Rural-5 Acre	Single Family Res-Combo
02 107470 RK	R-7,200	Residential 7,200 sq. ft.	Single Family Res-Combo
02 107480 RK	R-7,200	Residential 7,200 sq. ft.	Single Family Res-Combo
03 100505 RK	PRD-7,200	Residential 7,200 sq. ft.	SFR-Basic
02 109451 RK	PRD-7,200	Residential 7,200 sq. ft.	Single Family Res-Combo
02 107859 RK	PRD-7,200	Residential 7,200 sq. ft.	Single Family Res-Combo
03 102522 RK	PRD-7,200	Residential 7,200 sq. ft.	SFR-Basic
03 104106 RK	PRD-7,200	Residential 7,200 sq. ft.	Single Family Res-Combo
03 104994 RK	PRD-7,200	Residential 7,200 sq. ft.	SFR-Basic
03 104590 RK	PRD-7,200	Residential 7,200 sq. ft.	Single Family Res-Combo
03 100845 RK	PRD-7,200	Residential 7,200 sq. ft.	SFR-Basic
03 100830 RK	PRD-7,200	Residential 7,200 sq. ft.	SFR-Basic
03 100506 RK	PRD-7,200	Residential 7,200 sq. ft.	SFR-Basic
02 109833 RK	PRD-7,200	Residential 7,200 sq. ft.	Single Family Res-Combo
02 106381 RK	R-5	Rural-5 Acre	Single Family Res-Combo
02 105599 RK	MR	Multiple Residential	SFR-Basic
02 105596 RK	MR	Multiple Residential	SFR-Basic
02 109431 RK	PRD-7,200	Residential 7,200 sq. ft.	Single Family Res-Combo
02 109428 RK	PRD-7,200	Residential 7,200 sq. ft.	Single Family Res-Combo
02 105611 RK	MR	Multiple Residential	SFR-Basic
02 105612 RK	MR	Multiple Residential	SFR-Basic
02 105584 RK	MR	Multiple Residential	SFR-Basic
02 105585 RK	MR	Multiple Residential	SFR-Basic
02 105601 RK	MR	Multiple Residential	SFR-Basic
02 105605 RK	MR	Multiple Residential	SFR-Basic
02 105586 RK	MR	Multiple Residential	SFR-Basic
02 105598 RK	MR	Multiple Residential	SFR-Basic
02 105613 RK	MR	Multiple Residential	SFR-Basic
02 105610 RK	MR	Multiple Residential	SFR-Basic
03 101326 RK	R-7,200	Residential 7,200 sq. ft.	SFR-Basic
03 100292 RK	R-7,200	Residential 7,200 sq. ft.	SFR-Basic
03 100811 RK	R-7,200	Residential 7,200 sq. ft.	SFR-Basic
03 101328 RK	R-7,200	Residential 7,200 sq. ft.	SFR-Basic
03 100812 RK	R-7,200	Residential 7,200 sq. ft.	SFR-Basic
03 100291 RK	R-7,200	Residential 7,200 sq. ft.	SFR-Basic
03 100332 RK	CITY	City	SFR-Basic
03 101906 RK	R-5	Rural-5 Acre	SFR-Basic
03 100331 RK	CITY	City	SFR-Basic
03 100333 RK	CITY	City	SFR-Basic
03 102679 RK	CITY	City	SFR-Basic
03 100441 RK	CITY	City	SFR-Basic
03 102558 RK	CITY	City	SFR-Basic
03 100274 RK	CITY	City	SFR-Basic
03 102557 RK	CITY	City	SFR-Basic
03 101111 RK	CITY	City	SFR-Basic
03 103970 RK	CITY	City	SFR-Basic
03 103968 RK	CITY	City	SFR-Basic

Accessory Dwelling Units

Index # - File Name: 1.0022 - Single Family Dwellings Data\_Snohomish County.pdf

03 102560 RK	CITY	City	SFR-Basic
03 100537 RK	CITY	City	SFR-Basic
03 103969 RK	CITY	City	SFR-Basic
03 102387 RK	CITY	City	SFR-Basic
03 100273 RK	CITY	City	SFR-Basic
03 101364 RK	CITY	City	SFR-Basic
03 102123 RK	CITY	City	SFR-Basic
03 102680 RK	CITY	City	SFR-Basic
02 110571 RK	CITY	City	SFR-Basic
03 101791 RK	CITY	City	SFR-Basic
03 100444 RK	CITY	City	SFR-Basic
03 100443 RK	CITY	City	SFR-Basic
03 102389 RK	CITY	City	SFR-Basic
03 103971 RK	CITY	City	SFR-Basic
03 100538 RK	CITY	City	SFR-Basic
03 103967 RK	CITY	City	SFR-Basic
03 101790 RK	CITY	City	SFR-Basic
03 102122 RK	CITY	City	SFR-Basic
03 102121 RK	CITY	City	SFR-Basic
03 102124 RK	CITY	City	SFR-Basic
03 101361 RK	CITY	City	SFR-Basic
03 102559 RK	CITY	City	SFR-Basic
03 100275 RK	CITY	City	SFR-Basic
02 110574 RK	CITY	City	SFR-Basic
03 100276 RK	CITY	City	SFR-Basic
03 100009 RK	PRD-7,200	Residential 7,200 sq. ft.	SFR-Basic
03 100509 RK	PRD-7,200	Residential 7,200 sq. ft.	SFR-Basic
03 100008 RK	PRD-7,200	Residential 7,200 sq. ft.	SFR-Basic
03 100508 RK	PRD-7,200	Residential 7,200 sq. ft.	SFR-Basic
03 100510 RK	PRD-7,200	Residential 7,200 sq. ft.	SFR-Basic
03 107017 RK	R-9,600	Residential 9,600 sq. ft.	SFR-Basic
03 107941 RK	R-9,600	Residential 9,600 sq. ft.	SFR-Basic
03 105770 RK	R-9,600	Residential 9,600 sq. ft.	SFR-Basic
02 106134 MH	F : RC	Forestry : Rural Conservation	Double Wide
03 108680 RK			SFR-Basic
03 103016 RK	R-9,600	Residential 9,600 sq. ft.	SFR-Basic
02 104592 RK	PRD-9,600	Residential 9,600 sq. ft.	SFR-Basic
03 100631 RK	PRD-9,600	Residential 9,600 sq. ft.	SFR-Basic
03 100632 RK	PRD-9,600	Residential 9,600 sq. ft.	SFR-Basic
02 104586 RK	PRD-9,600	Residential 9,600 sq. ft.	SFR-Basic
02 104579 RK	PRD-9,600	Residential 9,600 sq. ft.	SFR-Basic
02 109158 RK	PRD-9,600	Residential 9,600 sq. ft.	Single Family Res-Combo
02 104587 RK	PRD-9,600	Residential 9,600 sq. ft.	SFR-Basic
02 104880 RK	PRD-9,600	Residential 9,600 sq. ft.	SFR-Basic
02 109160 RK	PRD-9,600	Residential 9,600 sq. ft.	Single Family Res-Combo
02 104854 RK	PRD-9,600	Residential 9,600 sq. ft.	SFR-Basic
03 100633 RK	PRD-9,600	Residential 9,600 sq. ft.	SFR-Basic

Accessory Dwelling Units

Index # - File Name: 1.0022 - Single Family Dwellings Data\_Snohomish County.pdf

02 104859 RK	PRD-9,600	Residential 9,600 sq. ft.	SFR-Basic
02 104853 RK	PRD-9,600	Residential 9,600 sq. ft.	SFR-Basic
02 104858 RK	PRD-9,600	Residential 9,600 sq. ft.	SFR-Basic
02 104868 RK	PRD-9,600	Residential 9,600 sq. ft.	SFR-Basic
02 104877 RK	PRD-9,600	Residential 9,600 sq. ft.	SFR-Basic
02 104851 RK	PRD-9,600	Residential 9,600 sq. ft.	SFR-Basic
02 104867 RK	PRD-9,600	Residential 9,600 sq. ft.	SFR-Basic
03 103586 RK	R-5	Rural-5 Acre	Single Family Res-Combo
02 109466 RK	A-10 : R-5	Agriculture-10 Acre : Rural-5	Single Family Res-Combo
02 104849 RK	PRD-9,600	Residential 9,600 sq. ft.	SFR-Basic
02 104865 RK	PRD-9,600	Residential 9,600 sq. ft.	SFR-Basic
02 104848 RK	PRD-9,600	Residential 9,600 sq. ft.	SFR-Basic
02 104876 RK	PRD-9,600	Residential 9,600 sq. ft.	SFR-Basic
02 104850 RK	PRD-9,600	Residential 9,600 sq. ft.	SFR-Basic
02 104875 RK	PRD-9,600	Residential 9,600 sq. ft.	SFR-Basic
02 104857 RK	PRD-9,600	Residential 9,600 sq. ft.	SFR-Basic
02 104862 RK	PRD-9,600	Residential 9,600 sq. ft.	SFR-Basic
02 104847 RK	PRD-9,600	Residential 9,600 sq. ft.	SFR-Basic
02 104874 RK	PRD-9,600	Residential 9,600 sq. ft.	SFR-Basic
02 104856 RK	PRD-9,600	Residential 9,600 sq. ft.	SFR-Basic
02 104870 RK	PRD-9,600	Residential 9,600 sq. ft.	SFR-Basic
02 104879 RK	PRD-9,600	Residential 9,600 sq. ft.	SFR-Basic
02 104852 RK	PRD-9,600	Residential 9,600 sq. ft.	SFR-Basic
02 104869 RK	PRD-9,600	Residential 9,600 sq. ft.	SFR-Basic
02 104878 RK	PRD-9,600	Residential 9,600 sq. ft.	SFR-Basic
02 104568 RK	PRD-9,600	Residential 9,600 sq. ft.	SFR-Basic
03 102537 RK	CITY	City	SFR-Basic
02 104564 RK	R-5	Rural-5 Acre	Single Family Res-Combo
02 104864 RK	PRD-9,600	Residential 9,600 sq. ft.	SFR-Basic
02 104726 RK	R-5	Rural-5 Acre	Single Family Res-Combo
02 109062 MH	R-5	Rural-5 Acre	Double Wide
03 100025 RK	R-5	Rural-5 Acre	Single Family Res-Combo
02 109327 RK	CITY	City	Single Family Res-Combo
02 104289 RK	R-5	Rural-5 Acre	Single Family Res-Combo
03 108113 RK	R-9,600	Residential 9,600 sq. ft.	Single Family Res-Combo
03 108104 RK	R-9,600	Residential 9,600 sq. ft.	Single Family Res-Combo
03 103674 RK	R-5	Rural-5 Acre	Single Family Res-Combo
03 101244 RK	R-5	Rural-5 Acre	Single Family Res-Combo
02 110393 RK	R-5	Rural-5 Acre	Single Family Res-Combo
02 110394 RK	R-5	Rural-5 Acre	Single Family Res-Combo
03 102175 RK	R-5	Rural-5 Acre	Single Family Res-Combo
02 110722 RK	CITY	City	Single Family Res-Combo
03 100484 RK	R-5	Rural-5 Acre	SFR-Basic
02 110290 RK	R-5	Rural-5 Acre	Single Family Res-Combo
03 100173 RK	R-9,600(PRD)	Residential 9,600 sq. ft.	SFR-Basic
03 100168 RK	R-9,600(PRD)	Residential 9,600 sq. ft.	SFR-Basic
03 100163 RK	R-9,600(PRD)	Residential 9,600 sq. ft.	SFR-Basic

Accessory Dwelling Units

Index # - File Name: 1.0022 - Single Family Dwellings Data\_Snohomish County.pdf

03 107944 RK	R-5	Rural-5 Acre	Single Family Res-Combo
03 101890 RK	R-9,600(PRD)	Residential 9,600 sq. ft.	SFR-Basic
03 100160 RK	R-9,600(PRD)	Residential 9,600 sq. ft.	SFR-Basic
03 100167 RK	R-9,600(PRD)	Residential 9,600 sq. ft.	SFR-Basic
03 102318 RK	R-9,600(PRD)	Residential 9,600 sq. ft.	SFR-Basic
03 100172 RK	R-9,600(PRD)	Residential 9,600 sq. ft.	SFR-Basic
03 100161 RK	R-9,600(PRD)	Residential 9,600 sq. ft.	SFR-Basic
03 101365 RK	R-9,600(PRD)	Residential 9,600 sq. ft.	SFR-Basic
03 100171 RK	R-9,600(PRD)	Residential 9,600 sq. ft.	SFR-Basic
03 100166 RK	R-9,600(PRD)	Residential 9,600 sq. ft.	SFR-Basic
03 101359 RK	R-9,600(PRD)	Residential 9,600 sq. ft.	SFR-Basic
03 100317 RK	R-9,600(PRD)	Residential 9,600 sq. ft.	SFR-Basic
03 101362 RK	R-9,600(PRD)	Residential 9,600 sq. ft.	SFR-Basic
03 100315 RK	R-9,600(PRD)	Residential 9,600 sq. ft.	SFR-Basic
03 100170 RK	R-9,600(PRD)	Residential 9,600 sq. ft.	SFR-Basic
03 100164 RK	R-9,600(PRD)	Residential 9,600 sq. ft.	SFR-Basic
03 102312 RK	R-9,600(PRD)	Residential 9,600 sq. ft.	SFR-Basic
03 101363 RK	R-9,600(PRD)	Residential 9,600 sq. ft.	SFR-Basic
03 102314 RK	R-9,600(PRD)	Residential 9,600 sq. ft.	SFR-Basic
03 102311 RK	R-9,600(PRD)	Residential 9,600 sq. ft.	SFR-Basic
03 102316 RK	R-9,600(PRD)	Residential 9,600 sq. ft.	SFR-Basic
03 102308 RK	R-9,600(PRD)	Residential 9,600 sq. ft.	SFR-Basic
03 102319 RK	R-9,600(PRD)	Residential 9,600 sq. ft.	SFR-Basic
03 101366 RK	R-9,600(PRD)	Residential 9,600 sq. ft.	SFR-Basic
03 102313 RK	R-9,600(PRD)	Residential 9,600 sq. ft.	SFR-Basic
03 101360 RK	R-9,600(PRD)	Residential 9,600 sq. ft.	SFR-Basic
03 102317 RK	R-9,600(PRD)	Residential 9,600 sq. ft.	SFR-Basic
03 102310 RK	R-9,600(PRD)	Residential 9,600 sq. ft.	SFR-Basic
03 102307 RK	R-9,600(PRD)	Residential 9,600 sq. ft.	SFR-Basic
03 100665 RK	R-9,600(PRD)	Residential 9,600 sq. ft.	SFR-Basic
03 100666 RK	R-9,600(PRD)	Residential 9,600 sq. ft.	SFR-Basic
03 109264 RK	R-5	Rural-5 Acre	Single Family Res-Combo
02 110320 RK	R-5	Rural-5 Acre	Single Family Res-Combo
03 102078 RK	R-5	Rural-5 Acre	Single Family Res-Combo
03 100366 RK	CITY	City	SFR-Basic
03 100312 RK	R-5	Rural-5 Acre	Single Family Res-Combo
02 110777 RK	CITY	City	SFR-Basic
02 110785 RK	CITY	City	SFR-Basic
02 110786 RK	CITY	City	SFR-Basic
03 100355 RK	CITY	City	SFR-Basic
03 101588 RK	CITY	City	SFR-Basic
03 101587 RK	CITY	City	SFR-Basic
03 101584 RK	CITY	City	SFR-Basic
03 101585 RK	CITY	City	SFR-Basic
03 101586 RK	CITY	City	SFR-Basic
03 101589 RK	CITY	City	SFR-Basic
03 100767 RK	R-5	Rural-5 Acre	SFR-Basic

Accessory Dwelling Units

Index # - File Name: 1.0022 - Single Family Dwellings Data\_Snohomish County.pdf

03 100367 RK	CITY	City	Single Family Res-Combo
03 101340 RK	CITY	City	SFR-Basic
03 100357 RK	CITY	City	SFR-Basic
03 110409 RK	R-9,600	Residential 9,600 sq. ft.	Single Family Res-Combo
03 104708 RK	R-9,600	Residential 9,600 sq. ft.	SFR-Basic
03 108115 RK	A-10	Agriculture-10 Acre	Single Family Res-Combo
03 100903 RK	CITY	City	SFR-Basic
03 108243 RK	CITY	City	Single Family Res-Combo
03 109594 RK	CITY	City	SFR-Basic
03 101239 RK	CITY	City	Single Family Res-Combo
03 101050 RK	CITY	City	Single Family Res-Combo
03 100904 RK	CITY	City	SFR-Basic
03 102748 RK	CITY	City	SFR-Basic
03 102103 RK	CITY	City	Single Family Res-Combo
03 100756 RK	CITY	City	Single Family Res-Combo
03 104706 RK	R-9,600	Residential 9,600 sq. ft.	SFR-Basic
03 109081 RK	R-5	Rural-5 Acre	Single Family Res-Combo
03 102948 RK	A-10	Agriculture-10 Acre	Single Family Res-Combo
02 109881 RK	R-5	Rural-5 Acre	Single Family Res-Combo
03 104611 RK	CITY	City	Single Family Res-Combo
03 104717 RK	CITY	City	SFR-Basic
03 105178 RK	CITY	City	SFR-Basic
03 108751 RK	CITY	City	SFR-Basic
03 106649 RK	CITY	City	SFR-Basic
03 103008 RK	CITY	City	Single Family Res-Combo
03 100480 RK	CITY	City	Single Family Res-Combo
02 110202 MH	R-5	Rural-5 Acre	Double Wide
03 105767 RK	CITY	City	SFR-Basic
03 106254 RK	CITY	City	SFR-Basic
03 109468 RK	CITY	City	SFR-Basic
03 109472 RK	CITY	City	SFR-Basic
03 108130 RK	CITY	City	Single Family Res-Combo
03 100586 RK	CITY	City	Single Family Res-Combo
03 107828 RK	CITY	City	Single Family Res-Combo
03 107830 RK	CITY	City	Single Family Res-Combo
02 109911 RK	R-7,200	Residential 7,200 sq. ft.	Single Family Res-Combo
03 101273 RK	R-7,200	Residential 7,200 sq. ft.	Single Family Res-Combo
03 101274 RK	R-7,200	Residential 7,200 sq. ft.	Single Family Res-Combo
03 105734 RK	R-7,200	Residential 7,200 sq. ft.	Single Family Res-Combo
03 100584 RK	CITY	City	Single Family Res-Combo
03 100523 RK	CITY	City	Single Family Res-Combo
03 102385 RK	CITY	City	SFR-Basic
03 100526 RK	CITY	City	Single Family Res-Combo
03 105756 RK	CITY	City	Single Family Res-Combo
03 107012 RK	CITY	City	SFR-Basic
03 108134 RK	CITY	City	Single Family Res-Combo
03 108131 RK	CITY	City	Single Family Res-Combo

Accessory Dwelling Units

Index # - File Name: 1.0022 - Single Family Dwellings Data\_Snohomish County.pdf

03 103006 RK	CITY	City	Single Family Res-Combo
03 102988 RK	CITY	City	SFR-Basic
03 102981 RK	CITY	City	SFR-Basic
03 100587 RK	CITY	City	Single Family Res-Combo
03 108123 RK	CITY	City	Single Family Res-Combo
03 100521 RK	CITY	City	Single Family Res-Combo
03 106121 RK	R-5	Rural-5 Acre	Single Family Res-Combo
03 105293 RK	R-5	Rural-5 Acre	Single Family Res-Combo
03 103453 RK	R-5	Rural-5 Acre	Single Family Res-Combo
03 103423 RK	R-5	Rural-5 Acre	Single Family Res-Combo
03 104459 RK	R-5	Rural-5 Acre	SFR-Basic
02 103749 RK	CITY	City	SFR-Basic
02 103752 RK	CITY	City	SFR-Basic
03 101352 RK	PRD-8,400	Residential 8,400 sq. ft.	SFR-Basic
03 101546 RK	PRD-8,400	Residential 8,400 sq. ft.	SFR-Basic
02 101008 RK	PRD-8,400	Residential 8,400 sq. ft.	SFR-Basic
03 101870 RK	PRD-8,400	Residential 8,400 sq. ft.	Single Family Res-Combo
03 100148 RK	PRD-8,400	Residential 8,400 sq. ft.	Single Family Res-Combo
02 105773 RK	PRD-9,600	Residential 9,600 sq. ft.	SFR-Basic
02 105759 RK	PRD-9,600	Residential 9,600 sq. ft.	SFR-Basic
02 105738 RK	PRD-9,600	Residential 9,600 sq. ft.	SFR-Basic
02 105772 RK	PRD-9,600	Residential 9,600 sq. ft.	SFR-Basic
02 105729 RK	PRD-9,600	Residential 9,600 sq. ft.	SFR-Basic
02 105771 RK	PRD-9,600	Residential 9,600 sq. ft.	SFR-Basic
03 100656 RK	PRD-8,400	Residential 8,400 sq. ft.	Duplex-Combo
02 108522 RK	PRD-8,400	Residential 8,400 sq. ft.	SFR-Basic
02 105007 RK	PRD-9,600	Residential 9,600 sq. ft.	SFR-Basic
02 104996 RK	PRD-9,600	Residential 9,600 sq. ft.	SFR-Basic
02 104986 RK	PRD-9,600	Residential 9,600 sq. ft.	SFR-Basic
02 104995 RK	PRD-9,600	Residential 9,600 sq. ft.	SFR-Basic
02 105028 RK	PRD-9,600	Residential 9,600 sq. ft.	SFR-Basic
02 105016 RK	PRD-9,600	Residential 9,600 sq. ft.	SFR-Basic
02 105024 RK	PRD-9,600	Residential 9,600 sq. ft.	SFR-Basic
02 104994 RK	PRD-9,600	Residential 9,600 sq. ft.	SFR-Basic
02 105015 RK	PRD-9,600	Residential 9,600 sq. ft.	SFR-Basic
02 105023 RK	PRD-9,600	Residential 9,600 sq. ft.	SFR-Basic
02 104993 RK	PRD-9,600	Residential 9,600 sq. ft.	SFR-Basic
02 105010 RK	PRD-9,600	Residential 9,600 sq. ft.	SFR-Basic
02 104989 RK	PRD-9,600	Residential 9,600 sq. ft.	SFR-Basic
02 105019 RK	PRD-9,600	Residential 9,600 sq. ft.	SFR-Basic
02 105009 RK	PRD-9,600	Residential 9,600 sq. ft.	SFR-Basic
02 104980 RK	PRD-9,600	Residential 9,600 sq. ft.	SFR-Basic
02 105000 RK	PRD-9,600	Residential 9,600 sq. ft.	SFR-Basic
02 104979 RK	PRD-9,600	Residential 9,600 sq. ft.	SFR-Basic
02 104988 RK	PRD-9,600	Residential 9,600 sq. ft.	SFR-Basic
02 105018 RK	PRD-9,600	Residential 9,600 sq. ft.	SFR-Basic
02 105008 RK	PRD-9,600	Residential 9,600 sq. ft.	SFR-Basic

Accessory Dwelling Units

Index # - File Name: 1.0022 - Single Family Dwellings Data\_Snohomish County.pdf

02 104999 RK	PRD-9,600	Residential 9,600 sq. ft.	SFR-Basic
02 104978 RK	PRD-9,600	Residential 9,600 sq. ft.	SFR-Basic
02 105017 RK	PRD-9,600	Residential 9,600 sq. ft.	SFR-Basic
02 104987 RK	PRD-9,600	Residential 9,600 sq. ft.	SFR-Basic
02 104998 RK	PRD-9,600	Residential 9,600 sq. ft.	SFR-Basic
02 104977 RK	PRD-9,600	Residential 9,600 sq. ft.	SFR-Basic
02 104985 RK	PRD-9,600	Residential 9,600 sq. ft.	SFR-Basic
02 105005 RK	PRD-9,600	Residential 9,600 sq. ft.	SFR-Basic
02 104992 RK	PRD-9,600	Residential 9,600 sq. ft.	SFR-Basic
02 105004 RK	PRD-9,600	Residential 9,600 sq. ft.	SFR-Basic
02 104984 RK	PRD-9,600	Residential 9,600 sq. ft.	SFR-Basic
02 105003 RK	PRD-9,600	Residential 9,600 sq. ft.	SFR-Basic
02 104991 RK	PRD-9,600	Residential 9,600 sq. ft.	SFR-Basic
02 104983 RK	PRD-9,600	Residential 9,600 sq. ft.	SFR-Basic
02 105013 RK	PRD-9,600	Residential 9,600 sq. ft.	SFR-Basic
02 105022 RK	PRD-9,600	Residential 9,600 sq. ft.	SFR-Basic
02 105002 RK	PRD-9,600	Residential 9,600 sq. ft.	SFR-Basic
02 104982 RK	PRD-9,600	Residential 9,600 sq. ft.	SFR-Basic
02 105747 RK	PRD-9,600	Residential 9,600 sq. ft.	SFR-Basic
02 105728 RK	PRD-9,600	Residential 9,600 sq. ft.	SFR-Basic
02 105756 RK	PRD-9,600	Residential 9,600 sq. ft.	SFR-Basic
02 105736 RK	PRD-9,600	Residential 9,600 sq. ft.	SFR-Basic
02 105755 RK	PRD-9,600	Residential 9,600 sq. ft.	SFR-Basic
02 105746 RK	PRD-9,600	Residential 9,600 sq. ft.	SFR-Basic
02 105763 RK	PRD-9,600	Residential 9,600 sq. ft.	SFR-Basic
02 105817 RK	PRD-9,600	Residential 9,600 sq. ft.	SFR-Basic
02 105769 RK	PRD-9,600	Residential 9,600 sq. ft.	SFR-Basic
02 105754 RK	PRD-9,600	Residential 9,600 sq. ft.	SFR-Basic
02 105745 RK	PRD-9,600	Residential 9,600 sq. ft.	SFR-Basic
02 105735 RK	PRD-9,600	Residential 9,600 sq. ft.	SFR-Basic
02 105727 RK	PRD-9,600	Residential 9,600 sq. ft.	SFR-Basic
02 105768 RK	PRD-9,600	Residential 9,600 sq. ft.	SFR-Basic
02 105753 RK	PRD-9,600	Residential 9,600 sq. ft.	SFR-Basic
02 105734 RK	PRD-9,600	Residential 9,600 sq. ft.	SFR-Basic
02 105733 RK	PRD-9,600	Residential 9,600 sq. ft.	SFR-Basic
02 105744 RK	PRD-9,600	Residential 9,600 sq. ft.	SFR-Basic
02 105767 RK	PRD-9,600	Residential 9,600 sq. ft.	SFR-Basic
02 105726 RK	PRD-9,600	Residential 9,600 sq. ft.	SFR-Basic
02 105752 RK	PRD-9,600	Residential 9,600 sq. ft.	SFR-Basic
02 105766 RK	PRD-9,600	Residential 9,600 sq. ft.	SFR-Basic
02 105742 RK	PRD-9,600	Residential 9,600 sq. ft.	SFR-Basic
02 105725 RK	PRD-9,600	Residential 9,600 sq. ft.	SFR-Basic
02 105765 RK	PRD-9,600	Residential 9,600 sq. ft.	SFR-Basic
02 105732 RK	PRD-9,600	Residential 9,600 sq. ft.	SFR-Basic
02 105751 RK	PRD-9,600	Residential 9,600 sq. ft.	SFR-Basic
02 105724 RK	PRD-9,600	Residential 9,600 sq. ft.	SFR-Basic
02 105764 RK	PRD-9,600	Residential 9,600 sq. ft.	SFR-Basic

Accessory Dwelling Units

Index # - File Name: 1.0022 - Single Family Dwellings Data\_Snohomish County.pdf

03 103675 RK	R-5	Rural-5 Acre	Single Family Res-Combo
03 101526 RK	R-5	Rural-5 Acre	Single Family Res-Combo
03 106128 RK	R-5	Rural-5 Acre	Single Family Res-Combo
03 104074 RK	R-5	Rural-5 Acre	Single Family Res-Combo
03 103474 RK	R-5	Rural-5 Acre	Single Family Res-Combo
03 104028 RK	R-5	Rural-5 Acre	SFR-Basic
03 102170 RK	R-5	Rural-5 Acre	SFR-Basic
03 101484 RK	R-5	Rural-5 Acre	SFR-Basic
03 103983 RK	R-5	Rural-5 Acre	Single Family Res-Combo
03 101966 RK	R-5	Rural-5 Acre	Single Family Res-Combo
03 101487 RK	R-5	Rural-5 Acre	SFR-Basic
03 101965 RK	R-5	Rural-5 Acre	Single Family Res-Combo
03 100199 RK	R-5	Rural-5 Acre	Single Family Res-Combo
03 106264 RK	R-5	Rural-5 Acre	Single Family Res-Combo
03 100198 RK	R-5	Rural-5 Acre	Single Family Res-Combo
03 101038 RK	R-5	Rural-5 Acre	Single Family Res-Combo
03 107079 RK	R-5	Rural-5 Acre	Single Family Res-Combo
02 109584 RK	R-5	Rural-5 Acre	Single Family Res-Combo
03 106614 RK	R-5	Rural-5 Acre	Single Family Res-Combo
03 101418 RK	R-5	Rural-5 Acre	Single Family Res-Combo
03 102677 RK	R-5	Rural-5 Acre	Single Family Res-Combo
03 100615 RK	R-5	Rural-5 Acre	Single Family Res-Combo
03 103973 RK	R-5	Rural-5 Acre	Single Family Res-Combo
03 109435 RK	R-5	Rural-5 Acre	SFR-Basic
03 105243 RK	R-5	Rural-5 Acre	Single Family Res-Combo
03 105559 RK	R-5	Rural-5 Acre	Single Family Res-Combo
03 108593 RK	R-5	Rural-5 Acre	SFR-Basic
03 103882 RK	R-5	Rural-5 Acre	Single Family Res-Combo
03 102779 RK	R-5	Rural-5 Acre	SFR-Basic
03 105944 RK	R-5	Rural-5 Acre	Single Family Res-Combo
03 105943 RK	R-5	Rural-5 Acre	Single Family Res-Combo
03 102780 RK	R-5	Rural-5 Acre	SFR-Basic
03 101412 RK	R-5	Rural-5 Acre	SFR-Basic
03 101413 RK	R-5	Rural-5 Acre	SFR-Basic
03 107940 RK	R-5	Rural-5 Acre	Single Family Res-Combo
02 110077 RK	CITY	City	Single Family Res-Combo
03 101094 RK	A-10 : R-5	Agriculture-10 Acre : Rural-5	Single Family Res-Combo
03 103650 RK	PRD-7,200	Residential 7,200 sq. ft.	SFR-Basic
03 103651 RK	PRD-7,200	Residential 7,200 sq. ft.	SFR-Basic
03 103652 RK	PRD-7,200	Residential 7,200 sq. ft.	SFR-Basic
03 103655 RK	PRD-7,200	Residential 7,200 sq. ft.	SFR-Basic
03 103656 RK	PRD-7,200	Residential 7,200 sq. ft.	SFR-Basic
03 104415 RK	PRD-7,200	Residential 7,200 sq. ft.	SFR-Basic
03 104227 RK	PRD-7,200	Residential 7,200 sq. ft.	SFR-Basic
03 104228 RK	PRD-7,200	Residential 7,200 sq. ft.	SFR-Basic
03 105377 RK	PRD-7,200	Residential 7,200 sq. ft.	SFR-Basic
03 104416 RK	PRD-7,200	Residential 7,200 sq. ft.	SFR-Basic



Accessory Dwelling Units

Index # - File Name: 1.0022 - Single Family Dwellings Data\_Snohomish County.pdf

03 105375 RK	PRD-7,200	Residential 7,200 sq. ft.	SFR-Basic
03 105530 RK	PRD-7,200	Residential 7,200 sq. ft.	SFR-Basic
03 105529 RK	PRD-7,200	Residential 7,200 sq. ft.	SFR-Basic
03 105532 RK	PRD-7,200	Residential 7,200 sq. ft.	SFR-Basic
03 105969 RK	PRD-7,200	Residential 7,200 sq. ft.	SFR-Basic
03 105970 RK	PRD-7,200	Residential 7,200 sq. ft.	SFR-Basic
03 105971 RK	PRD-7,200	Residential 7,200 sq. ft.	SFR-Basic
03 106224 RK	PRD-7,200	Residential 7,200 sq. ft.	SFR-Basic
03 106225 RK	PRD-7,200	Residential 7,200 sq. ft.	SFR-Basic
03 106226 RK	PRD-7,200	Residential 7,200 sq. ft.	SFR-Basic
03 105972 RK	PRD-7,200	Residential 7,200 sq. ft.	SFR-Basic
03 105973 RK	PRD-7,200	Residential 7,200 sq. ft.	SFR-Basic
03 106448 RK	PRD-7,200	Residential 7,200 sq. ft.	SFR-Basic
03 106449 RK	PRD-7,200	Residential 7,200 sq. ft.	SFR-Basic
03 106450 RK	PRD-7,200	Residential 7,200 sq. ft.	SFR-Basic
03 109298 RK	PRD-9,600	Residential 9,600 sq. ft.	SFR-Basic
03 108786 RK	PRD-9,600	Residential 9,600 sq. ft.	SFR-Basic
03 109299 RK	PRD-9,600	Residential 9,600 sq. ft.	SFR-Basic
03 109302 RK	PRD-9,600	Residential 9,600 sq. ft.	SFR-Basic
03 108787 RK	PRD-9,600	Residential 9,600 sq. ft.	SFR-Basic
03 108789 RK	PRD-9,600	Residential 9,600 sq. ft.	SFR-Basic
03 107251 RK	PRD-9,600	Residential 9,600 sq. ft.	SFR-Basic
03 107572 RK	PRD-9,600	Residential 9,600 sq. ft.	SFR-Basic
03 107573 RK	PRD-9,600	Residential 9,600 sq. ft.	SFR-Basic
03 106718 RK	PRD-9,600	Residential 9,600 sq. ft.	SFR-Basic
03 106262 RK	PRD-9,600	Residential 9,600 sq. ft.	SFR-Basic
03 106261 RK	PRD-9,600	Residential 9,600 sq. ft.	SFR-Basic
03 105683 RK	PRD-9,600	Residential 9,600 sq. ft.	SFR-Basic
03 105682 RK	PRD-9,600	Residential 9,600 sq. ft.	SFR-Basic
03 104484 RK	PRD-9,600	Residential 9,600 sq. ft.	SFR-Basic
03 104485 RK	PRD-9,600	Residential 9,600 sq. ft.	SFR-Basic
03 104013 RK	PRD-9,600	Residential 9,600 sq. ft.	SFR-Basic
03 103347 RK	PRD-9,600	Residential 9,600 sq. ft.	SFR-Basic
03 108790 RK	PRD-9,600	Residential 9,600 sq. ft.	SFR-Basic
03 109297 RK	PRD-9,600	Residential 9,600 sq. ft.	SFR-Basic
03 109326 RK	PRD-9,600	Residential 9,600 sq. ft.	SFR-Basic
03 108791 RK	PRD-9,600	Residential 9,600 sq. ft.	SFR-Basic
03 106719 RK	PRD-9,600	Residential 9,600 sq. ft.	SFR-Basic
03 107574 RK	PRD-9,600	Residential 9,600 sq. ft.	SFR-Basic
03 106720 RK	PRD-9,600	Residential 9,600 sq. ft.	SFR-Basic
03 106721 RK	PRD-9,600	Residential 9,600 sq. ft.	SFR-Basic
03 106722 RK	PRD-9,600	Residential 9,600 sq. ft.	SFR-Basic
03 106260 RK	PRD-9,600	Residential 9,600 sq. ft.	SFR-Basic
03 106258 RK	PRD-9,600	Residential 9,600 sq. ft.	SFR-Basic
03 105684 RK	PRD-9,600	Residential 9,600 sq. ft.	SFR-Basic
03 105685 RK	PRD-9,600	Residential 9,600 sq. ft.	SFR-Basic
03 104486 RK	PRD-9,600	Residential 9,600 sq. ft.	SFR-Basic

Accessory Dwelling Units

Index # - File Name: 1.0022 - Single Family Dwellings Data\_Snohomish County.pdf

03 104487 RK	PRD-9,600	Residential 9,600 sq. ft.	SFR-Basic
03 104012 RK	PRD-9,600	Residential 9,600 sq. ft.	SFR-Basic
03 104014 RK	PRD-9,600	Residential 9,600 sq. ft.	SFR-Basic
03 104015 RK	PRD-9,600	Residential 9,600 sq. ft.	SFR-Basic
03 104016 RK	PRD-9,600	Residential 9,600 sq. ft.	SFR-Basic
03 104017 RK	PRD-9,600	Residential 9,600 sq. ft.	SFR-Basic
03 103751 RK	CITY	City	SFR-Basic
03 103162 RK	CITY	City	SFR-Basic
03 103163 RK	CITY	City	Single Family Res-Combo
03 103512 RK	CITY	City	SFR-Basic
03 107834 RK	CITY	City	SFR-Basic
03 103513 RK	CITY	City	SFR-Basic
03 103514 RK	CITY	City	SFR-Basic
03 103515 RK	CITY	City	SFR-Basic
03 105437 RK	CITY	City	SFR-Basic
03 103516 RK	CITY	City	SFR-Basic
03 107833 RK	CITY	City	SFR-Basic
03 107832 RK	CITY	City	SFR-Basic
03 103517 RK	CITY	City	SFR-Basic
03 103518 RK	CITY	City	SFR-Basic
03 105438 RK	CITY	City	SFR-Basic
03 103520 RK	CITY	City	SFR-Basic
03 104152 RK	CITY	City	SFR-Basic
03 103522 RK	CITY	City	SFR-Basic
03 104153 RK	CITY	City	SFR-Basic
03 104154 RK	CITY	City	SFR-Basic
03 105439 RK	CITY	City	SFR-Basic
03 104155 RK	CITY	City	SFR-Basic
03 103379 RK	CITY	City	Single Family Res-Combo
03 104156 RK	CITY	City	SFR-Basic
03 104157 RK	CITY	City	SFR-Basic
03 106155 RK	CITY	City	SFR-Basic
03 106153 RK	CITY	City	SFR-Basic
03 104158 RK	CITY	City	SFR-Basic
03 104159 RK	CITY	City	SFR-Basic
03 106156 RK	CITY	City	SFR-Basic
03 106157 RK	CITY	City	SFR-Basic
03 105436 RK	CITY	City	SFR-Basic
03 104160 RK	CITY	City	SFR-Basic
03 108900 RK	R-9,600	Residential 9,600 sq. ft.	Single Family Res-Combo
03 105747 RK	R-9,600	Residential 9,600 sq. ft.	Single Family Res-Combo
03 109995 RK	R-9,600	Residential 9,600 sq. ft.	Single Family Res-Combo
03 101908 RK	R-9,600	Residential 9,600 sq. ft.	Single Family Res-Combo
03 101909 RK	R-9,600	Residential 9,600 sq. ft.	Single Family Res-Combo
03 101012 RK	R-9,600	Residential 9,600 sq. ft.	Single Family Res-Combo
03 101169 RK	R-9,600	Residential 9,600 sq. ft.	Single Family Res-Combo
03 101910 RK	R-9,600	Residential 9,600 sq. ft.	Single Family Res-Combo

Accessory Dwelling Units

Index # - File Name: 1.0022 - Single Family Dwellings Data\_Snohomish County.pdf

03 101933 RK	R-9,600	Residential 9,600 sq. ft.	Single Family Res-Combo
03 101936 RK	R-9,600	Residential 9,600 sq. ft.	Single Family Res-Combo
03 106332 RK	R-9,600	Residential 9,600 sq. ft.	Single Family Res-Combo
03 106994 RK	R-9,600	Residential 9,600 sq. ft.	Single Family Res-Combo
03 106993 RK	R-9,600	Residential 9,600 sq. ft.	Single Family Res-Combo
03 108840 RK	R-9,600	Residential 9,600 sq. ft.	Single Family Res-Combo
03 109820 RK	R-9,600	Residential 9,600 sq. ft.	Single Family Res-Combo
03 108839 RK	R-9,600	Residential 9,600 sq. ft.	Single Family Res-Combo
03 108838 RK	R-9,600	Residential 9,600 sq. ft.	Single Family Res-Combo
03 104469 RK	R-9,600	Residential 9,600 sq. ft.	Single Family Res-Combo
03 104470 RK	R-9,600	Residential 9,600 sq. ft.	Single Family Res-Combo
03 104471 RK	R-9,600	Residential 9,600 sq. ft.	Single Family Res-Combo
03 101939 RK	R-9,600	Residential 9,600 sq. ft.	Single Family Res-Combo
03 105025 RK	R-9,600	Residential 9,600 sq. ft.	Single Family Res-Combo
03 101934 RK	R-9,600	Residential 9,600 sq. ft.	Single Family Res-Combo
03 100803 RK	R-9,600	Residential 9,600 sq. ft.	Single Family Res-Combo
03 100804 RK	R-9,600	Residential 9,600 sq. ft.	Single Family Res-Combo
03 101015 RK	R-9,600	Residential 9,600 sq. ft.	Single Family Res-Combo
03 101017 RK	R-9,600	Residential 9,600 sq. ft.	Single Family Res-Combo
03 101168 RK	R-9,600	Residential 9,600 sq. ft.	Single Family Res-Combo
03 101540 MH	R-5	Rural-5 Acre	Triple Wide
03 102647 RK	R-5	Rural-5 Acre	Single Family Res-Combo
03 103330 RK	R-7,200	Residential 7,200 sq. ft.	SFR-Basic
03 103639 RK	R-7,200	Residential 7,200 sq. ft.	SFR-Basic
03 103331 RK	R-7,200	Residential 7,200 sq. ft.	SFR-Basic
03 102420 RK	R-7,200	Residential 7,200 sq. ft.	Single Family Res-Combo
03 104082 RK	R-7,200	Residential 7,200 sq. ft.	SFR-Basic
03 103333 RK	R-7,200	Residential 7,200 sq. ft.	SFR-Basic
03 104081 RK	R-7,200	Residential 7,200 sq. ft.	SFR-Basic
03 104083 RK	R-7,200	Residential 7,200 sq. ft.	SFR-Basic
03 102419 RK	R-7,200	Residential 7,200 sq. ft.	Single Family Res-Combo
03 102674 RK	R-5	Rural-5 Acre	Single Family Res-Combo
03 106140 RK	R-5	Rural-5 Acre	SFR-Basic
03 108236 RK	R-7,200	Residential 7,200 sq. ft.	SFR-Basic
03 108616 RK	R-7,200	Residential 7,200 sq. ft.	SFR-Basic
03 110407 RK	R-7,200	Residential 7,200 sq. ft.	SFR-Basic
03 110964 RK	R-7,200	Residential 7,200 sq. ft.	SFR-Basic
03 105065 RK	R-7,200	Residential 7,200 sq. ft.	SFR-Basic
03 106231 RK	R-7,200	Residential 7,200 sq. ft.	SFR-Basic
03 109534 RK	R-7,200	Residential 7,200 sq. ft.	SFR-Basic
03 103547 RK	R-7,200	Residential 7,200 sq. ft.	Single Family Res-Combo
03 105064 RK	R-7,200	Residential 7,200 sq. ft.	SFR-Basic
03 103544 RK	R-7,200	Residential 7,200 sq. ft.	SFR-Basic
03 102776 RK	CITY	City	Single Family Res-Combo
03 103957 RK	R-5	Rural-5 Acre	Single Family Res-Combo
03 104086 RK	R-7,200	Residential 7,200 sq. ft.	SFR-Basic
03 103891 RK	R-7,200	Residential 7,200 sq. ft.	SFR-Basic

Accessory Dwelling Units

Index # - File Name: 1.0022 - Single Family Dwellings Data\_Snohomish County.pdf

03 104326 RK	R-7,200	Residential 7,200 sq. ft.	SFR-Basic
03 104494 RK	R-7,200	Residential 7,200 sq. ft.	SFR-Basic
03 104872 RK	R-7,200	Residential 7,200 sq. ft.	SFR-Basic
03 104874 RK	R-7,200	Residential 7,200 sq. ft.	SFR-Basic
03 104327 RK	R-7,200	Residential 7,200 sq. ft.	SFR-Basic
03 104496 RK	R-7,200	Residential 7,200 sq. ft.	SFR-Basic
03 107513 RK	R-7,200	Residential 7,200 sq. ft.	Single Family Res-Combo
03 106864 RK	R-5	Rural-5 Acre	Single Family Res-Combo
03 105651 RK	LDMR	Low Density Multiple Reside	SFR-Basic
03 103729 RK	LDMR	Low Density Multiple Reside	Single Family Res-Combo
03 103728 RK	LDMR	Low Density Multiple Reside	Single Family Res-Combo
03 103730 RK	LDMR	Low Density Multiple Reside	Single Family Res-Combo
03 105216 RK	LDMR	Low Density Multiple Reside	SFR-Basic
03 103031 RK	R-5	Rural-5 Acre	Single Family Res-Combo
03 103727 RK	LDMR	Low Density Multiple Reside	Single Family Res-Combo
03 105088 RK	LDMR	Low Density Multiple Reside	SFR-Basic
03 103731 RK	LDMR	Low Density Multiple Reside	Single Family Res-Combo
03 105089 RK	LDMR	Low Density Multiple Reside	SFR-Basic
03 105090 RK	LDMR	Low Density Multiple Reside	SFR-Basic
03 105082 RK	LDMR	Low Density Multiple Reside	SFR-Basic
03 105091 RK	LDMR	Low Density Multiple Reside	SFR-Basic
03 105087 RK	LDMR	Low Density Multiple Reside	SFR-Basic
03 105084 RK	LDMR	Low Density Multiple Reside	SFR-Basic
03 105085 RK	LDMR	Low Density Multiple Reside	SFR-Basic
03 105079 RK	LDMR	Low Density Multiple Reside	SFR-Basic
03 105217 RK	LDMR	Low Density Multiple Reside	SFR-Basic
03 109588 RK	LDMR	Low Density Multiple Reside	SFR-Basic
03 105652 RK	LDMR	Low Density Multiple Reside	SFR-Basic
03 103438 RK	CITY	City	SFR-Basic
03 103437 RK	CITY	City	SFR-Basic
03 103439 RK	CITY	City	SFR-Basic
03 104425 RK	CITY	City	SFR-Basic
03 105144 RK	CITY	City	SFR-Basic
03 106232 RK	CITY	City	SFR-Basic
03 106234 RK	CITY	City	SFR-Basic
03 107170 RK	CITY	City	SFR-Basic
03 107169 RK	CITY	City	SFR-Basic
03 107621 RK	CITY	City	SFR-Basic
03 106227 RK	CITY	City	Single Family Res-Combo
03 106228 RK	CITY	City	SFR-Basic
03 106229 RK	CITY	City	SFR-Basic
03 105371 RK	CITY	City	SFR-Basic
03 105372 RK	CITY	City	SFR-Basic
03 110499 RK	CITY	City	SFR-Basic
03 110500 RK	CITY	City	SFR-Basic
03 110504 RK	CITY	City	SFR-Basic
03 108797 RK	CITY	City	SFR-Basic

Accessory Dwelling Units

Index # - File Name: 1.0022 - Single Family Dwellings Data\_Snohomish County.pdf

03 108798 RK	CITY	City	SFR-Basic
03 108799 RK	CITY	City	SFR-Basic
03 110181 RK	CITY	City	SFR-Basic
03 105148 RK	CITY	City	SFR-Basic
03 104886 RK	CITY	City	SFR-Basic
03 104888 RK	CITY	City	SFR-Basic
03 105149 RK	CITY	City	SFR-Basic
03 105150 RK	CITY	City	SFR-Basic
03 108990 RK	CITY	City	SFR-Basic
03 108988 RK	CITY	City	SFR-Basic
03 103860 RK	CITY	City	SFR-Basic
03 103862 RK	CITY	City	SFR-Basic
03 103864 RK	CITY	City	SFR-Basic
03 102951 RK	R-8,400	Residential 8,400 sq. ft.	Single Family Res-Combo
03 102967 RK	R-5	Rural-5 Acre	Single Family Res-Combo
03 109589 RK	LDMR	Low Density Multiple Reside	SFR-Basic
03 103732 RK	LDMR	Low Density Multiple Reside	Single Family Res-Combo
03 110187 RK	CITY	City	SFR-Basic
03 107626 RK	CITY	City	Single Family Res-Combo
03 107623 RK	CITY	City	SFR-Basic
03 107624 RK	CITY	City	SFR-Basic
03 105373 RK	CITY	City	SFR-Basic
03 105374 RK	CITY	City	SFR-Basic
03 107625 RK	CITY	City	SFR-Basic
03 103181 RK	F : R-5	Forestry : Rural-5 Acre	Single Family Res-Combo
03 103861 RK	CITY	City	SFR-Basic
03 100790 RK	R-7,200	Residential 7,200 sq. ft.	Duplex-Combo
03 103466 RK	R-7,200	Residential 7,200 sq. ft.	SFR-Basic
03 103459 RK	R-7,200	Residential 7,200 sq. ft.	SFR-Basic
03 109311 RK	CITY	City	SFR-Basic
03 104546 RK	R-5	Rural-5 Acre	Single Family Res-Combo
03 103742 RK	R-5	Rural-5 Acre	SFR-Basic
02 110104 RK	R-5	Rural-5 Acre	Single Family Res-Combo
03 103540 RK	F	Forestry	Single Family Res-Combo
03 105804 RK	R-5	Rural-5 Acre	Single Family Res-Combo
03 109613 RK	R-5	Rural-5 Acre	Single Family Res-Combo
03 106386 MH	RD	Rural Diversification	Double Wide
03 103756 RK	R-5	Rural-5 Acre	SFR-Basic
03 103763 RK	R-9,600	Residential 9,600 sq. ft.	Duplex-Combo
03 105478 RK	R-9,600	Residential 9,600 sq. ft.	SFR-Basic
03 105487 RK	R-9,600	Residential 9,600 sq. ft.	SFR-Basic
03 105475 RK	R-9,600	Residential 9,600 sq. ft.	SFR-Basic
03 106330 RK	R-9,600	Residential 9,600 sq. ft.	SFR-Basic
03 106839 RK	R-9,600	Residential 9,600 sq. ft.	SFR-Basic
03 106836 RK	R-9,600	Residential 9,600 sq. ft.	SFR-Basic
03 109107 RK	R-9,600	Residential 9,600 sq. ft.	SFR-Basic
03 107638 RK	R-9,600	Residential 9,600 sq. ft.	SFR-Basic

Accessory Dwelling Units

Index # - File Name: 1.0022 - Single Family Dwellings Data\_Snohomish County.pdf

03 106838 RK	R-9,600	Residential 9,600 sq. ft.	SFR-Basic
03 106845 RK	R-9,600	Residential 9,600 sq. ft.	SFR-Basic
03 106843 RK	R-9,600	Residential 9,600 sq. ft.	SFR-Basic
03 106835 RK	R-9,600	Residential 9,600 sq. ft.	SFR-Basic
03 106842 RK	R-9,600	Residential 9,600 sq. ft.	SFR-Basic
03 105479 RK	R-9,600	Residential 9,600 sq. ft.	SFR-Basic
03 105488 RK	R-9,600	Residential 9,600 sq. ft.	SFR-Basic
03 105489 RK	R-9,600	Residential 9,600 sq. ft.	SFR-Basic
03 105480 RK	R-9,600	Residential 9,600 sq. ft.	SFR-Basic
03 105490 RK	R-9,600	Residential 9,600 sq. ft.	SFR-Basic
03 105481 RK	R-9,600	Residential 9,600 sq. ft.	SFR-Basic
03 105482 RK	R-9,600	Residential 9,600 sq. ft.	SFR-Basic
03 105491 RK	R-9,600	Residential 9,600 sq. ft.	SFR-Basic
03 105483 RK	R-9,600	Residential 9,600 sq. ft.	SFR-Basic
03 106833 RK	R-9,600	Residential 9,600 sq. ft.	SFR-Basic
03 106841 RK	R-9,600	Residential 9,600 sq. ft.	SFR-Basic
03 106844 RK	R-9,600	Residential 9,600 sq. ft.	SFR-Basic
03 106328 RK	R-9,600	Residential 9,600 sq. ft.	SFR-Basic
03 108031 RK	R-9,600	Residential 9,600 sq. ft.	SFR-Basic
03 108882 RK	R-9,600	Residential 9,600 sq. ft.	SFR-Basic
03 108032 RK	R-9,600	Residential 9,600 sq. ft.	SFR-Basic
03 108034 RK	R-9,600	Residential 9,600 sq. ft.	SFR-Basic
03 107639 RK	R-9,600	Residential 9,600 sq. ft.	SFR-Basic
03 108033 RK	R-9,600	Residential 9,600 sq. ft.	SFR-Basic
03 110890 RK	R-9,600	Residential 9,600 sq. ft.	SFR-Basic
03 105486 RK	R-9,600	Residential 9,600 sq. ft.	SFR-Basic
03 108030 RK	R-9,600	Residential 9,600 sq. ft.	SFR-Basic
03 108675 RK	R-9,600	Residential 9,600 sq. ft.	Single Family Res-Combo
03 105473 RK	R-9,600	Residential 9,600 sq. ft.	SFR-Basic
03 106382 RK	R-7,200	Residential 7,200 sq. ft.	Duplex-Combo
03 106092 RK	CITY	City	SFR-Basic
03 106434 RK	CITY	City	SFR-Basic
03 103285 RK	CITY	City	Single Family Res-Combo
03 103284 RK	CITY	City	Single Family Res-Combo
03 103286 RK	CITY	City	Single Family Res-Combo
03 103283 RK	CITY	City	Single Family Res-Combo
03 105571 RK	CITY	City	Single Family Res-Combo
03 105568 RK	CITY	City	Duplex-Combo
03 109528 RK	RRT-10	Rural Resource Transition-10	Single Family Res-Combo
03 104218 MH	F	Forestry	Double Wide
01 106561 RK	R-5	Rural-5 Acre	SFR-Basic
03 104809 RK	CITY	City	SFR-Basic
03 104307 RK	R-5	Rural-5 Acre	Single Family Res-Combo
03 104278 RK	R-5	Rural-5 Acre	Single Family Res-Combo
03 108814 RK	CITY	City	SFR-Basic
03 108812 RK	CITY	City	Single Family Res-Combo
03 104521 MH	R-5	Rural-5 Acre	Triple Wide

Accessory Dwelling Units

Index # - File Name: 1.0022 - Single Family Dwellings Data\_Snohomish County.pdf

03 104441 RK	RRT-10	Rural Resource Transition-1(Single Family Res-Combo	
03 104443 RK	RRT-10	Rural Resource Transition-1(Single Family Res-Combo	
03 102974 RK	RRT-10	Rural Resource Transition-1(Single Family Res-Combo	
03 104599 RK	RRT-10	Rural Resource Transition-1(SFR-Basic	
03 104661 RK	R-9,600	Residential 9,600 sq. ft.	Single Family Res-Combo
03 104662 RK	R-9,600	Residential 9,600 sq. ft.	Single Family Res-Combo
03 104664 RK	R-9,600	Residential 9,600 sq. ft.	Single Family Res-Combo
03 104402 MH	R-5	Rural-5 Acre	Double Wide
03 102994 RK	PRD-7,200	Residential 7,200 sq. ft.	Single Family Res-Combo
03 102995 RK	PRD-7,200	Residential 7,200 sq. ft.	Single Family Res-Combo
03 105289 RK	R-5	Rural-5 Acre	Single Family Res-Combo
03 104727 RK	R-5	Rural-5 Acre	Single Family Res-Combo
03 108384 RK	PRD-7,200	Residential 7,200 sq. ft.	SFR-Basic
03 109554 RK	PRD-7,200	Residential 7,200 sq. ft.	SFR-Basic
03 109559 RK	PRD-7,200	Residential 7,200 sq. ft.	SFR-Basic
03 110874 RK	PRD-7,200	Residential 7,200 sq. ft.	Single Family Res-Combo
03 109558 RK	PRD-7,200	Residential 7,200 sq. ft.	SFR-Basic
03 101084 RK	PRD-7,200	Residential 7,200 sq. ft.	Single Family Res-Combo
03 101087 RK	PRD-7,200	Residential 7,200 sq. ft.	Single Family Res-Combo
03 106344 RK	PRD-7,200	Residential 7,200 sq. ft.	SFR-Basic
03 106347 RK	PRD-7,200	Residential 7,200 sq. ft.	SFR-Basic
03 105008 RK	PRD-7,200	Residential 7,200 sq. ft.	SFR-Basic
03 103021 RK	PRD-7,200	Residential 7,200 sq. ft.	Single Family Res-Combo
03 105009 RK	PRD-7,200	Residential 7,200 sq. ft.	SFR-Basic
03 103018 RK	PRD-7,200	Residential 7,200 sq. ft.	Single Family Res-Combo
03 106348 RK	PRD-7,200	Residential 7,200 sq. ft.	SFR-Basic
03 106349 RK	PRD-7,200	Residential 7,200 sq. ft.	SFR-Basic
03 108455 RK	PRD-7,200	Residential 7,200 sq. ft.	SFR-Basic
03 107915 RK	PRD-7,200	Residential 7,200 sq. ft.	SFR-Basic
03 109556 RK	PRD-7,200	Residential 7,200 sq. ft.	SFR-Basic
03 109555 RK	PRD-7,200	Residential 7,200 sq. ft.	SFR-Basic
03 110677 RK	CITY	City	SFR-Basic
03 109118 RK	CITY	City	SFR-Basic
03 109119 RK	CITY	City	SFR-Basic
03 109114 RK	CITY	City	SFR-Basic
03 106331 RK	CITY	City	SFR-Basic
03 108038 RK	CITY	City	SFR-Basic
03 108042 RK	CITY	City	SFR-Basic
03 108039 RK	CITY	City	SFR-Basic
03 107641 RK	CITY	City	SFR-Basic
03 108040 RK	CITY	City	SFR-Basic
03 108041 RK	CITY	City	SFR-Basic
03 106044 RK	CITY	City	SFR-Basic
03 106059 RK	CITY	City	SFR-Basic
03 106045 RK	CITY	City	SFR-Basic
03 110892 RK	CITY	City	SFR-Basic
03 106831 RK	CITY	City	SFR-Basic

Accessory Dwelling Units

Index # - File Name: 1.0022 - Single Family Dwellings Data\_Snohomish County.pdf

03 106048 RK	CITY	City	SFR-Basic
03 106049 RK	CITY	City	SFR-Basic
03 106052 RK	CITY	City	SFR-Basic
03 106054 RK	CITY	City	SFR-Basic
03 106060 RK	CITY	City	SFR-Basic
03 106055 RK	CITY	City	SFR-Basic
03 106046 RK	CITY	City	SFR-Basic
03 106056 RK	CITY	City	SFR-Basic
03 106050 RK	CITY	City	SFR-Basic
03 106051 RK	CITY	City	SFR-Basic
03 106061 RK	CITY	City	SFR-Basic
03 106047 RK	CITY	City	SFR-Basic
03 106057 RK	CITY	City	SFR-Basic
03 108037 RK	CITY	City	SFR-Basic
03 108036 RK	CITY	City	SFR-Basic
03 108035 RK	CITY	City	SFR-Basic
03 107646 RK	CITY	City	SFR-Basic
03 106832 RK	CITY	City	SFR-Basic
03 110891 RK	CITY	City	SFR-Basic
03 109111 RK	CITY	City	SFR-Basic
03 109113 RK	CITY	City	SFR-Basic
03 109115 RK	CITY	City	SFR-Basic
03 109109 RK	CITY	City	SFR-Basic
03 109110 RK	CITY	City	SFR-Basic
03 109116 RK	CITY	City	SFR-Basic
03 109117 RK	CITY	City	SFR-Basic
03 110896 RK	CITY	City	SFR-Basic
03 110895 RK	CITY	City	SFR-Basic
03 110893 RK	CITY	City	SFR-Basic
03 110897 RK	CITY	City	SFR-Basic
03 104996 MH	R-5	Rural-5 Acre	Double Wide
03 105039 RK	R-5	Rural-5 Acre	Single Family Res-Combo
03 110640 RK	PRD-7,200	Residential 7,200 sq. ft.	SFR-Basic
03 104731 RK	R-5	Rural-5 Acre	Single Family Res-Combo
03 104225 RK	R-5	Rural-5 Acre	Single Family Res-Combo
03 104810 RK	F	Forestry	Single Family Res-Combo
03 104812 RK	R-5	Rural-5 Acre	Single Family Res-Combo
03 109108 RK	CITY	City	SFR-Basic
03 107644 RK	CITY	City	SFR-Basic
03 107643 RK	CITY	City	SFR-Basic
03 107647 RK	CITY	City	SFR-Basic
03 104666 RK	A-10	Agriculture-10 Acre	Single Family Res-Combo
03 110678 RK	CITY	City	SFR-Basic
03 110679 RK	CITY	City	SFR-Basic
03 105249 RK	WFB	Waterfront Beach	Single Family Res-Combo
03 108439 RK	CITY	City	Single Family Res-Combo
03 107931 RK	CITY	City	Single Family Res-Combo



Accessory Dwelling Units

Index # - File Name: 1.0022 - Single Family Dwellings Data\_Snohomish County.pdf

03 108086 RK	CITY	City	Single Family Res-Combo
03 107816 RK	CITY	City	Single Family Res-Combo
03 110149 RK	CITY	City	SFR-Basic
03 110150 RK	CITY	City	SFR-Basic
03 105219 RK	R-5	Rural-5 Acre	SFR-Basic
03 105465 RK	R-5	Rural-5 Acre	Single Family Res-Combo
03 107815 RK	CITY	City	Single Family Res-Combo
03 105393 RK	R-5	Rural-5 Acre	Single Family Res-Combo
03 108246 RK	CITY	City	Duplex-Basic
03 108238 RK	CITY	City	Duplex-Basic
03 107135 RK	CITY	City	Duplex-Combo
03 107123 RK	CITY	City	Duplex-Combo
03 108240 RK	CITY	City	Duplex-Basic
03 105885 RK	R-5	Rural-5 Acre	Single Family Res-Combo
03 110151 RK	CITY	City	SFR-Basic
03 108438 RK	CITY	City	Single Family Res-Combo
03 108437 RK	CITY	City	Single Family Res-Combo
03 107456 RK	CITY	City	SFR-Basic
03 107457 RK	CITY	City	SFR-Basic
03 107459 RK	CITY	City	SFR-Basic
03 108963 RK	CITY	City	SFR-Basic
03 110694 RK	CITY	City	SFR-Basic
03 106549 RK	LDMR	Low Density Multiple Reside	SFR-Basic
03 106819 RK	LDMR	Low Density Multiple Reside	SFR-Basic
03 106820 RK	LDMR	Low Density Multiple Reside	SFR-Basic
03 108417 RK	LDMR	Low Density Multiple Reside	SFR-Basic
03 106552 RK	LDMR	Low Density Multiple Reside	Single Family Res-Combo
03 106551 RK	LDMR	Low Density Multiple Reside	Single Family Res-Combo
03 105134 RK	LDMR	Low Density Multiple Reside	Single Family Res-Combo
03 105821 RK	LDMR	Low Density Multiple Reside	Single Family Res-Combo
03 105369 RK	R-5	Rural-5 Acre	Single Family Res-Combo
03 110883 RK	LDMR	Low Density Multiple Reside	SFR-Basic
03 110882 RK	LDMR	Low Density Multiple Reside	SFR-Basic
03 110218 RK	LDMR	Low Density Multiple Reside	SFR-Basic
03 106550 RK	LDMR	Low Density Multiple Reside	SFR-Basic
03 109560 RK	R-8,400	Residential 8,400 sq. ft.	Single Family Res-Combo
02 110441 RK	R-8,400	Residential 8,400 sq. ft.	Single Family Res-Combo
03 106826 RK	R-7,200	Residential 7,200 sq. ft.	Duplex-Basic
03 105779 RK	R-5	Rural-5 Acre	Single Family Res-Combo
03 105798 RK	R-5	Rural-5 Acre	Single Family Res-Combo
03 105823 RK	F	Forestry	Single Family Res-Combo
03 106637 RK	R-9,600	Residential 9,600 sq. ft.	Single Family Res-Combo
03 106639 RK	R-9,600	Residential 9,600 sq. ft.	Single Family Res-Combo
03 107335 RK	R-9,600	Residential 9,600 sq. ft.	Single Family Res-Combo
03 107336 RK	R-9,600	Residential 9,600 sq. ft.	Single Family Res-Combo
03 107344 RK	R-9,600	Residential 9,600 sq. ft.	Single Family Res-Combo
03 107348 RK	R-9,600	Residential 9,600 sq. ft.	Single Family Res-Combo

Accessory Dwelling Units

Index # - File Name: 1.0022 - Single Family Dwellings Data\_Snohomish County.pdf

03 108775 RK	R-9,600	Residential 9,600 sq. ft.	SFR-Basic
03 109941 RK	R-9,600	Residential 9,600 sq. ft.	SFR-Basic
03 106638 RK	R-9,600	Residential 9,600 sq. ft.	Single Family Res-Combo
03 109938 RK	R-9,600	Residential 9,600 sq. ft.	Single Family Res-Combo
03 108909 RK	R-9,600	Residential 9,600 sq. ft.	Single Family Res-Combo
03 107977 RK	R-5	Rural-5 Acre	Single Family Res-Combo
03 106069 MH	R-5	Rural-5 Acre	Double Wide
03 105817 RK	R-5	Rural-5 Acre	Single Family Res-Combo
03 105814 RK	R-5	Rural-5 Acre	Single Family Res-Combo
03 106974 RK	R-5	Rural-5 Acre	Single Family Res-Combo
03 107713 RK	R-9,600	Residential 9,600 sq. ft.	Single Family Res-Combo
03 106233 RK	R-5	Rural-5 Acre	Single Family Res-Combo
03 106259 RK	R-5	Rural-5 Acre	Single Family Res-Combo
03 105433 RK	R-7,200	Residential 7,200 sq. ft.	Single Family Res-Combo
03 104628 RK	R-7,200	Residential 7,200 sq. ft.	Single Family Res-Combo
03 106821 RK	R-7,200	Residential 7,200 sq. ft.	SFR-Basic
03 107635 RK	R-7,200	Residential 7,200 sq. ft.	SFR-Basic
03 104629 RK	R-7,200	Residential 7,200 sq. ft.	Single Family Res-Combo
03 107340 RK	R-7,200	Residential 7,200 sq. ft.	SFR-Basic
03 103653 RK	R-7,200	Residential 7,200 sq. ft.	Single Family Res-Combo
03 105432 RK	R-7,200	Residential 7,200 sq. ft.	Single Family Res-Combo
03 110881 RK	R-7,200	Residential 7,200 sq. ft.	SFR-Basic
03 104633 RK	R-7,200	Residential 7,200 sq. ft.	Single Family Res-Combo
03 101475 RK	R-7,200	Residential 7,200 sq. ft.	Single Family Res-Combo
03 109005 RK	R-7,200	Residential 7,200 sq. ft.	SFR-Basic
03 104632 RK	R-7,200	Residential 7,200 sq. ft.	Single Family Res-Combo
03 107338 RK	R-7,200	Residential 7,200 sq. ft.	SFR-Basic
03 109240 RK	R-7,200	Residential 7,200 sq. ft.	SFR-Basic
03 108418 RK	R-7,200	Residential 7,200 sq. ft.	SFR-Basic
03 104631 RK	R-7,200	Residential 7,200 sq. ft.	Single Family Res-Combo
03 108419 RK	R-7,200	Residential 7,200 sq. ft.	SFR-Basic
03 107634 RK	R-7,200	Residential 7,200 sq. ft.	SFR-Basic
03 109482 RK	R-7,200	Residential 7,200 sq. ft.	SFR-Basic
03 109239 RK	R-7,200	Residential 7,200 sq. ft.	SFR-Basic
03 107668 RK	R-7,200	Residential 7,200 sq. ft.	SFR-Basic
03 106823 RK	R-7,200	Residential 7,200 sq. ft.	SFR-Basic
03 107669 RK	R-7,200	Residential 7,200 sq. ft.	SFR-Basic
03 106822 RK	R-7,200	Residential 7,200 sq. ft.	SFR-Basic
03 104630 RK	R-7,200	Residential 7,200 sq. ft.	Single Family Res-Combo
03 106825 RK	R-7,200	Residential 7,200 sq. ft.	SFR-Basic
03 107511 RK	R-7,200	Residential 7,200 sq. ft.	Duplex-Combo
03 106973 RK	CITY	City	Single Family Res-Combo
03 108185 RK	R-5	Rural-5 Acre	Single Family Res-Combo
03 108187 RK	R-5	Rural-5 Acre	Single Family Res-Combo
03 108232 RK	R-5	Rural-5 Acre	Single Family Res-Combo
03 107351 RK	R-5	Rural-5 Acre	Single Family Res-Combo
03 106582 MH	R-5	Rural-5 Acre	Double Wide

Accessory Dwelling Units

Index # - File Name: 1.0022 - Single Family Dwellings Data\_Snohomish County.pdf

03 108375 RK	PRD-7,200	Residential 7,200 sq. ft.	SFR-Basic
03 108892 RK	PRD-7,200	Residential 7,200 sq. ft.	SFR-Basic
03 107319 RK	PRD-7,200	Residential 7,200 sq. ft.	Single Family Res-Combo
03 110981 RK	PRD-7,200	Residential 7,200 sq. ft.	SFR-Basic
03 109923 RK	PRD-7,200	Residential 7,200 sq. ft.	SFR-Basic
03 108991 RK	PRD-7,200	Residential 7,200 sq. ft.	SFR-Basic
03 108996 RK	PRD-7,200	Residential 7,200 sq. ft.	SFR-Basic
03 109920 RK	PRD-7,200	Residential 7,200 sq. ft.	SFR-Basic
03 108495 RK	PRD-7,200	Residential 7,200 sq. ft.	Single Family Res-Combo
03 108498 RK	PRD-7,200	Residential 7,200 sq. ft.	Single Family Res-Combo
03 107320 RK	PRD-7,200	Residential 7,200 sq. ft.	SFR-Basic
03 107564 RK	PRD-7,200	Residential 7,200 sq. ft.	SFR-Basic
03 108377 RK	PRD-7,200	Residential 7,200 sq. ft.	SFR-Basic
03 107222 RK	PRD-7,200	Residential 7,200 sq. ft.	SFR-Basic
03 107227 RK	PRD-7,200	Residential 7,200 sq. ft.	SFR-Basic
03 107231 RK	PRD-7,200	Residential 7,200 sq. ft.	SFR-Basic
03 107566 RK	PRD-7,200	Residential 7,200 sq. ft.	SFR-Basic
03 107230 RK	PRD-7,200	Residential 7,200 sq. ft.	SFR-Basic
03 108887 RK	PRD-7,200	Residential 7,200 sq. ft.	SFR-Basic
03 108890 RK	PRD-7,200	Residential 7,200 sq. ft.	SFR-Basic
03 107565 RK	PRD-7,200	Residential 7,200 sq. ft.	SFR-Basic
03 107224 RK	PRD-7,200	Residential 7,200 sq. ft.	SFR-Basic
03 107225 RK	PRD-7,200	Residential 7,200 sq. ft.	SFR-Basic
03 107228 RK	PRD-7,200	Residential 7,200 sq. ft.	SFR-Basic
03 107229 RK	PRD-7,200	Residential 7,200 sq. ft.	SFR-Basic
03 107223 RK	PRD-7,200	Residential 7,200 sq. ft.	SFR-Basic
03 106624 RK	R-9,600	Residential 9,600 sq. ft.	Single Family Res-Combo
03 106625 RK	R-5	Rural-5 Acre	Single Family Res-Combo
03 106628 RK	RC	Rural Conservation	Single Family Res-Combo
03 106789 RK	RC	Rural Conservation	Single Family Res-Combo
03 106787 RK	RC	Rural Conservation	Single Family Res-Combo
03 106675 RK	R-9,600	Residential 9,600 sq. ft.	Single Family Res-Combo
03 106942 RK	R-9,600	Residential 9,600 sq. ft.	Single Family Res-Combo
03 106956 RK	R-5	Rural-5 Acre	Single Family Res-Combo
03 106923 RK	R-5	Rural-5 Acre	SFR-Basic
03 105467 RK	R-5	Rural-5 Acre	Single Family Res-Combo
03 105413 RK	R-5	Rural-5 Acre	Single Family Res-Combo
03 106980 RK	R-5	Rural-5 Acre	Single Family Res-Combo
03 110867 RK	R-7,200	Residential 7,200 sq. ft.	SFR-Basic
03 110866 RK	R-7,200	Residential 7,200 sq. ft.	SFR-Basic
03 110183 RK	R-7,200	Residential 7,200 sq. ft.	SFR-Basic
03 109624 RK	R-7,200	Residential 7,200 sq. ft.	Single Family Res-Combo
03 107354 RK	R-5	Rural-5 Acre	Single Family Res-Combo
03 107363 RK	R-5	Rural-5 Acre	Single Family Res-Combo
03 109470 RK	R-7,200	Residential 7,200 sq. ft.	SFR-Basic
03 108986 RK	R-7,200	Residential 7,200 sq. ft.	SFR-Basic
03 108987 RK	R-7,200	Residential 7,200 sq. ft.	SFR-Basic

Accessory Dwelling Units

Index # - File Name: 1.0022 - Single Family Dwellings Data\_Snohomish County.pdf

03 109469 RK	R-7,200	Residential 7,200 sq. ft.	SFR-Basic
03 111035 RK	R-7,200	Residential 7,200 sq. ft.	SFR-Basic
03 111034 RK	R-7,200	Residential 7,200 sq. ft.	SFR-Basic
03 108136 RK	R-5	Rural-5 Acre	Single Family Res-Combo
03 107550 RK	RC	Rural Conservation	Single Family Res-Combo
03 107841 RK	R-5	Rural-5 Acre	Single Family Res-Combo
03 109357 RK	R-5	Rural-5 Acre	Single Family Res-Combo
03 109167 RK	R-5	Rural-5 Acre	SFR-Basic
03 109172 RK	R-5	Rural-5 Acre	Single Family Res-Combo
03 106525 RK	CITY	City	Single Family Res-Combo
03 106530 RK	CITY	City	Single Family Res-Combo
03 106528 RK	CITY	City	Single Family Res-Combo
03 106526 RK	CITY	City	Single Family Res-Combo
03 106566 RK	CITY	City	Single Family Res-Combo
03 106565 RK	CITY	City	Single Family Res-Combo
03 107238 RK	CITY	City	Single Family Res-Combo
03 107242 RK	CITY	City	Single Family Res-Combo
03 108192 RK	CITY	City	Single Family Res-Combo
03 107673 RK	CITY	City	Single Family Res-Combo
03 107237 RK	CITY	City	Single Family Res-Combo
03 107243 RK	CITY	City	Single Family Res-Combo
03 106571 RK	CITY	City	Single Family Res-Combo
03 106572 RK	CITY	City	Single Family Res-Combo
03 104700 RK	CITY	City	Single Family Res-Combo
03 104701 RK	CITY	City	Single Family Res-Combo
03 105503 RK	CITY	City	Single Family Res-Combo
03 108194 RK	CITY	City	Single Family Res-Combo
03 108901 RK	CITY	City	Single Family Res-Combo
03 108841 RK	CITY	City	Single Family Res-Combo
03 108902 RK	CITY	City	Single Family Res-Combo
03 108904 RK	CITY	City	Single Family Res-Combo
03 106568 RK	CITY	City	Single Family Res-Combo
03 108193 RK	CITY	City	Single Family Res-Combo
03 107676 RK	CITY	City	Single Family Res-Combo
03 106983 RK	CITY	City	Single Family Res-Combo
03 106533 RK	CITY	City	Single Family Res-Combo
03 106532 RK	CITY	City	Single Family Res-Combo
03 106529 RK	CITY	City	Single Family Res-Combo
03 109945 RK	CITY	City	SFR-Basic
03 109627 RK	CITY	City	SFR-Basic
03 110618 RK	CITY	City	SFR-Basic
03 110616 RK	CITY	City	SFR-Basic
03 109947 RK	CITY	City	SFR-Basic
03 109496 RK	CITY	City	SFR-Basic
03 110619 RK	CITY	City	SFR-Basic
03 110617 RK	CITY	City	SFR-Basic
03 110620 RK	CITY	City	SFR-Basic

Accessory Dwelling Units

Index # - File Name: 1.0022 - Single Family Dwellings Data\_Snohomish County.pdf

03 109632 RK	CITY	City	SFR-Basic
03 110296 RK	CITY	City	SFR-Basic
03 109495 RK	CITY	City	SFR-Basic
03 104277 RK	LDMR	Low Density Multiple Reside	Single Family Res-Combo
03 104279 RK	LDMR	Low Density Multiple Reside	Duplex-Combo
03 104281 RK	LDMR	Low Density Multiple Reside	Duplex-Combo
03 104699 RK	CITY	City	Single Family Res-Combo
03 104696 RK	CITY	City	Single Family Res-Combo
03 104697 RK	CITY	City	Single Family Res-Combo
03 109144 RK	R-7,200	Residential 7,200 sq. ft.	Single Family Res-Combo
03 108402 RK	R-7,200	Residential 7,200 sq. ft.	Single Family Res-Combo
03 108407 RK	R-7,200	Residential 7,200 sq. ft.	Single Family Res-Combo
03 109003 RK	R-7,200	Residential 7,200 sq. ft.	Single Family Res-Combo
03 109001 RK	R-7,200	Residential 7,200 sq. ft.	Single Family Res-Combo
03 108400 RK	R-7,200	Residential 7,200 sq. ft.	Single Family Res-Combo
03 109486 RK	R-7,200	Residential 7,200 sq. ft.	SFR-Basic
03 107678 RK	CITY	City	Single Family Res-Combo
03 107240 RK	CITY	City	Single Family Res-Combo
03 108403 RK	R-7,200	Residential 7,200 sq. ft.	Single Family Res-Combo
03 108871 RK	R-8,400	Residential 8,400 sq. ft.	SFR-Basic
03 108872 RK	R-8,400	Residential 8,400 sq. ft.	SFR-Basic
03 108869 RK	R-8,400	Residential 8,400 sq. ft.	SFR-Basic
03 109819 RK	R-9,600	Residential 9,600 sq. ft.	Single Family Res-Combo
03 109818 RK	R-9,600	Residential 9,600 sq. ft.	Single Family Res-Combo
03 109027 RK	R-7,200	Residential 7,200 sq. ft.	Single Family Res-Combo
03 109029 RK	R-7,200	Residential 7,200 sq. ft.	Single Family Res-Combo
03 109991 RK	R-9,600	Residential 9,600 sq. ft.	Single Family Res-Combo
03 108673 RK	RRT-10	Rural Resource Transition-10	Single Family Res-Combo
03 108905 RK	R-5	Rural-5 Acre	Single Family Res-Combo
03 109031 RK	A-10	Agriculture-10 Acre	Single Family Res-Combo
03 108426 RK	R-7,200	Residential 7,200 sq. ft.	Single Family Res-Combo
03 108585 RK	R-7,200	Residential 7,200 sq. ft.	Single Family Res-Combo
03 108427 RK	R-7,200	Residential 7,200 sq. ft.	Single Family Res-Combo
03 108586 RK	R-7,200	Residential 7,200 sq. ft.	Single Family Res-Combo
03 109416 RK	R-7,200	Residential 7,200 sq. ft.	Single Family Res-Combo
03 109417 RK	R-7,200	Residential 7,200 sq. ft.	Single Family Res-Combo
03 109423 RK	R-7,200	Residential 7,200 sq. ft.	Single Family Res-Combo
03 109420 RK	R-7,200	Residential 7,200 sq. ft.	Single Family Res-Combo
03 108584 RK	R-7,200	Residential 7,200 sq. ft.	Single Family Res-Combo
03 107823 RK	PRD-9,600	Residential 9,600 sq. ft.	Single Family Res-Combo
03 107290 RK	PRD-9,600	Residential 9,600 sq. ft.	Single Family Res-Combo
03 110659 RK	PRD-9,600	Residential 9,600 sq. ft.	SFR-Basic
03 108847 RK	R-5	Rural-5 Acre	Single Family Res-Combo
03 109902 RK	R-5	Rural-5 Acre	SFR-Basic
03 109857 RK	R-5	Rural-5 Acre	SFR-Basic
03 109901 RK	R-5	Rural-5 Acre	SFR-Basic
03 109856 RK	R-5	Rural-5 Acre	SFR-Basic

Accessory Dwelling Units

Index # - File Name: 1.0022 - Single Family Dwellings Data\_Snohomish County.pdf

03 109944 RK	R-5	Rural-5 Acre	SFR-Basic
03 109971 RK	R-5	Rural-5 Acre	SFR-Basic
03 109070 RK	R-5	Rural-5 Acre	Single Family Res-Combo
03 110579 RK	R-5	Rural-5 Acre	SFR-Basic
03 110433 RK	R-5	Rural-5 Acre	Single Family Res-Combo
03 108140 RK	LDMR	Low Density Multiple Reside	Single Family Res-Combo
03 111032 RK	LDMR	Low Density Multiple Reside	Single Family Res-Combo
03 109827 RK	R-5	Rural-5 Acre	SFR-Basic
03 108858 RK	PRD-7,200	Residential 7,200 sq. ft.	Single Family Res-Combo
03 109381 RK	PRD-7,200	Residential 7,200 sq. ft.	Single Family Res-Combo
03 107730 RK	PRD-7,200	Residential 7,200 sq. ft.	Single Family Res-Combo
03 110998 RK	PRD-7,200	Residential 7,200 sq. ft.	SFR-Basic
03 107731 RK	PRD-7,200	Residential 7,200 sq. ft.	SFR-Basic
03 107732 RK	PRD-7,200	Residential 7,200 sq. ft.	Single Family Res-Combo
03 110995 RK	PRD-7,200	Residential 7,200 sq. ft.	SFR-Basic
03 110023 RK	PRD-7,200	Residential 7,200 sq. ft.	Single Family Res-Combo
03 111000 RK	PRD-7,200	Residential 7,200 sq. ft.	SFR-Basic
03 109382 RK	PRD-7,200	Residential 7,200 sq. ft.	Single Family Res-Combo
03 110996 RK	PRD-7,200	Residential 7,200 sq. ft.	SFR-Basic
03 109383 RK	PRD-7,200	Residential 7,200 sq. ft.	Single Family Res-Combo
03 110993 RK	PRD-7,200	Residential 7,200 sq. ft.	SFR-Basic
03 110935 RK	CITY	City	SFR-Basic
03 110938 RK	CITY	City	SFR-Basic
04 110234 RK	R-5	Rural-5 Acre	Single Family Res-Combo
03 111018 RK	F	Forestry	Single Family Res-Combo
04 112782 RK	CITY	City	Single Family Res-Combo
04 113307 RK	R-5	Rural-5 Acre	SFR-Basic
04 110969 RK	R-7,200	Residential 7,200 sq. ft.	SFR-Basic
04 110966 RK	R-7,200	Residential 7,200 sq. ft.	SFR-Basic
04 110971 RK	R-7,200	Residential 7,200 sq. ft.	SFR-Basic
04 110970 RK	R-7,200	Residential 7,200 sq. ft.	SFR-Basic
04 111397 RK			SFR-Basic
04 116654 RK	R-9,600	Residential 9,600 sq. ft.	Single Family Res-Combo
04 111855 RK	R-7,200	Residential 7,200 sq. ft.	SFR-Basic
04 110326 RK	CITY	City	SFR-Basic
04 110973 RK	R-7,200	Residential 7,200 sq. ft.	SFR-Basic
04 110967 RK	R-7,200	Residential 7,200 sq. ft.	SFR-Basic
04 112765 RK	R-7,200	Residential 7,200 sq. ft.	SFR-Basic
04 109875 RK	R-7,200	Residential 7,200 sq. ft.	Single Family Res-Combo
04 109873 RK	R-7,200	Residential 7,200 sq. ft.	Single Family Res-Combo
04 109879 RK	R-7,200	Residential 7,200 sq. ft.	Single Family Res-Combo
04 109880 RK	R-7,200	Residential 7,200 sq. ft.	Single Family Res-Combo
04 110960 RK	R-7,200	Residential 7,200 sq. ft.	SFR-Basic
04 110974 RK	R-7,200	Residential 7,200 sq. ft.	SFR-Basic
04 115917 RK	R-7,200	Residential 7,200 sq. ft.	Single Family Res-Combo
04 109876 RK	R-7,200	Residential 7,200 sq. ft.	Single Family Res-Combo
04 108889 RK	MR	Multiple Residential	SFR-Basic

Accessory Dwelling Units

Index # - File Name: 1.0022 - Single Family Dwellings Data\_Snohomish County.pdf

04 100189 RK	F	Forestry	SFR-Basic
04 100152 RK	R-9,600	Residential 9,600 sq. ft.	Single Family Res-Combo
04 100307 RK	R-5	Rural-5 Acre	Single Family Res-Combo
04 109359 RK	R-5	Rural-5 Acre	Single Family Res-Combo
04 108507 RK	R-5	Rural-5 Acre	Single Family Res-Combo
04 108510 RK	R-5	Rural-5 Acre	Single Family Res-Combo
04 114910 RK	CITY	City	SFR-Basic
04 100188 RK	R-7,200	Residential 7,200 sq. ft.	SFR-Basic
04 109821 RK	R-7,200	Residential 7,200 sq. ft.	Duplex-Combo
04 112294 RK	R-5	Rural-5 Acre	Single Family Res-Combo
04 113698 RK	R-5	Rural-5 Acre	Single Family Res-Combo
04 114854 MH	R-5	Rural-5 Acre	Double Wide
04 108625 RK	R-5	Rural-5 Acre	Single Family Res-Combo
04 109250 RK	R-5	Rural-5 Acre	SFR-Basic
04 100129 RK	R-5	Rural-5 Acre	Single Family Res-Combo
04 112394 RK	R-5	Rural-5 Acre	SFR-Basic
04 112391 RK	R-5	Rural-5 Acre	SFR-Basic
04 112389 RK	R-5	Rural-5 Acre	SFR-Basic
04 113769 RK	R-5	Rural-5 Acre	SFR-Basic
04 113770 RK	R-5	Rural-5 Acre	SFR-Basic
04 114044 RK	R-5	Rural-5 Acre	SFR-Basic
04 112396 RK	R-5	Rural-5 Acre	SFR-Basic
04 109197 RK	R-5	Rural-5 Acre	SFR-Basic
04 108755 RK	R-5	Rural-5 Acre	Single Family Res-Combo
04 108876 MH	R-5	Rural-5 Acre	Double Wide
04 109018 RK	CITY	City	SFR-Basic
04 109016 RK	CITY	City	SFR-Basic
04 116693 RK	CITY	City	Duplex-Combo
04 109014 RK	CITY	City	SFR-Basic
04 116519 RK	R-7,200	Residential 7,200 sq. ft.	Single Family Res-Combo
04 109015 RK	R-5	Rural-5 Acre	Single Family Res-Combo
04 111168 RK	R-7,200	Residential 7,200 sq. ft.	SFR-Basic
04 112216 RK	R-7,200	Residential 7,200 sq. ft.	SFR-Basic
04 112217 RK	R-7,200	Residential 7,200 sq. ft.	SFR-Basic
04 113146 RK	R-7,200	Residential 7,200 sq. ft.	SFR-Basic
04 113140 RK	R-7,200	Residential 7,200 sq. ft.	SFR-Basic
04 113145 RK	R-7,200	Residential 7,200 sq. ft.	SFR-Basic
04 113773 RK	R-7,200	Residential 7,200 sq. ft.	SFR-Basic
04 113774 RK	R-7,200	Residential 7,200 sq. ft.	SFR-Basic
04 113775 RK	R-7,200	Residential 7,200 sq. ft.	SFR-Basic
04 113776 RK	R-7,200	Residential 7,200 sq. ft.	SFR-Basic
04 112224 RK	R-7,200	Residential 7,200 sq. ft.	SFR-Basic
04 115344 RK	R-5	Rural-5 Acre	SFR-Basic
04 114079 RK	R-5	Rural-5 Acre	Single Family Res-Combo
04 114084 RK	R-5	Rural-5 Acre	Single Family Res-Combo
04 119975 RK	R-5	Rural-5 Acre	Single Family Res-Combo
04 114083 RK	R-5	Rural-5 Acre	Single Family Res-Combo

Accessory Dwelling Units

Index # - File Name: 1.0022 - Single Family Dwellings Data\_Snohomish County.pdf

04 115340 RK	R-5	Rural-5 Acre	SFR-Basic
04 114961 RK	R-5	Rural-5 Acre	SFR-Basic
04 114071 RK	R-5	Rural-5 Acre	Single Family Res-Combo
04 114960 RK	R-5	Rural-5 Acre	SFR-Basic
04 116626 RK	R-5	Rural-5 Acre	Single Family Res-Combo
04 116629 RK	R-5	Rural-5 Acre	Single Family Res-Combo
04 114519 RK	R-9,600	Residential 9,600 sq. ft.	SFR-Basic
04 116454 RK	R-9,600	Residential 9,600 sq. ft.	SFR-Basic
03 110674 RK	R-9,600	Residential 9,600 sq. ft.	Single Family Res-Combo
04 115598 RK	R-9,600	Residential 9,600 sq. ft.	SFR-Basic
04 113157 RK	R-9,600	Residential 9,600 sq. ft.	SFR-Basic
04 119546 RK	R-9,600	Residential 9,600 sq. ft.	SFR-Basic
03 110212 RK	R-9,600	Residential 9,600 sq. ft.	Single Family Res-Combo
04 119620 RK	R-9,600	Residential 9,600 sq. ft.	SFR-Basic
04 113035 RK	R-9,600	Residential 9,600 sq. ft.	SFR-Basic
04 119543 RK	R-9,600	Residential 9,600 sq. ft.	SFR-Basic
04 116458 RK	R-9,600	Residential 9,600 sq. ft.	SFR-Basic
04 113032 RK	R-9,600	Residential 9,600 sq. ft.	SFR-Basic
04 116452 RK	R-9,600	Residential 9,600 sq. ft.	SFR-Basic
04 117638 RK	R-9,600	Residential 9,600 sq. ft.	SFR-Basic
04 110513 RK	R-9,600	Residential 9,600 sq. ft.	Single Family Res-Combo
04 111207 RK	R-9,600	Residential 9,600 sq. ft.	Single Family Res-Combo
04 113383 RK	R-9,600	Residential 9,600 sq. ft.	Single Family Res-Combo
04 110011 RK	R-9,600	Residential 9,600 sq. ft.	Single Family Res-Combo
04 113384 RK	R-9,600	Residential 9,600 sq. ft.	Single Family Res-Combo
04 113389 RK	R-9,600	Residential 9,600 sq. ft.	Single Family Res-Combo
04 111433 RK	R-9,600	Residential 9,600 sq. ft.	Single Family Res-Combo
04 111432 RK	R-9,600	Residential 9,600 sq. ft.	Single Family Res-Combo
04 110010 RK	R-9,600	Residential 9,600 sq. ft.	Single Family Res-Combo
04 111435 RK	R-9,600	Residential 9,600 sq. ft.	Single Family Res-Combo
04 110669 RK	R-9,600	Residential 9,600 sq. ft.	Single Family Res-Combo
04 110012 RK	R-9,600	Residential 9,600 sq. ft.	Single Family Res-Combo
04 113386 RK	R-9,600	Residential 9,600 sq. ft.	Single Family Res-Combo
04 110013 RK	R-9,600	Residential 9,600 sq. ft.	Single Family Res-Combo
04 110663 RK	R-9,600	Residential 9,600 sq. ft.	Single Family Res-Combo
04 111002 RK	R-9,600	Residential 9,600 sq. ft.	Single Family Res-Combo
04 119615 RK	R-9,600	Residential 9,600 sq. ft.	SFR-Basic
04 115304 RK	R-9,600	Residential 9,600 sq. ft.	SFR-Basic
04 118155 RK	R-9,600	Residential 9,600 sq. ft.	SFR-Basic
04 117643 RK	R-9,600	Residential 9,600 sq. ft.	SFR-Basic
04 116250 RK	R-9,600	Residential 9,600 sq. ft.	SFR-Basic
03 110864 RK	R-9,600	Residential 9,600 sq. ft.	Single Family Res-Combo
04 111704 RK	R-9,600	Residential 9,600 sq. ft.	SFR-Basic
04 109882 RK	R-9,600	Residential 9,600 sq. ft.	Single Family Res-Combo
04 109099 RK	R-8,400	Residential 8,400 sq. ft.	Single Family Res-Combo
04 110912 RK	R-8,400	Residential 8,400 sq. ft.	SFR-Basic
04 110916 RK	R-8,400	Residential 8,400 sq. ft.	SFR-Basic



Accessory Dwelling Units

Index # - File Name: 1.0022 - Single Family Dwellings Data\_Snohomish County.pdf

04 111794 RK	R-8,400	Residential 8,400 sq. ft.	SFR-Basic
04 112961 RK	R-8,400	Residential 8,400 sq. ft.	SFR-Basic
04 114431 RK	R-8,400	Residential 8,400 sq. ft.	SFR-Basic
04 112956 RK	R-8,400	Residential 8,400 sq. ft.	SFR-Basic
04 111798 RK	R-8,400	Residential 8,400 sq. ft.	SFR-Basic
04 114432 RK	R-8,400	Residential 8,400 sq. ft.	SFR-Basic
04 109308 RK	R-8,400	Residential 8,400 sq. ft.	Single Family Res-Combo
04 110932 RK	R-8,400	Residential 8,400 sq. ft.	SFR-Basic
04 110933 RK	R-8,400	Residential 8,400 sq. ft.	SFR-Basic
04 110935 RK	R-8,400	Residential 8,400 sq. ft.	SFR-Basic
04 108880 RK	R-8,400	Residential 8,400 sq. ft.	Single Family Res-Combo
04 108878 RK	R-8,400	Residential 8,400 sq. ft.	Single Family Res-Combo
04 108879 RK	R-8,400	Residential 8,400 sq. ft.	Single Family Res-Combo
04 110937 RK	R-8,400	Residential 8,400 sq. ft.	SFR-Basic
04 110938 RK	R-8,400	Residential 8,400 sq. ft.	SFR-Basic
04 108882 RK	R-8,400	Residential 8,400 sq. ft.	Single Family Res-Combo
04 100272 RK	PRD-7,200	Residential 7,200 sq. ft.	SFR-Basic
04 115162 RK	R-7,200	Residential 7,200 sq. ft.	SFR-Basic
04 109572 RK	R-7,200	Residential 7,200 sq. ft.	SFR-Basic
04 109996 RK	R-7,200	Residential 7,200 sq. ft.	SFR-Basic
04 109985 RK	R-7,200	Residential 7,200 sq. ft.	SFR-Basic
04 109992 RK	R-7,200	Residential 7,200 sq. ft.	SFR-Basic
04 109990 RK	R-7,200	Residential 7,200 sq. ft.	SFR-Basic
04 109983 RK	R-7,200	Residential 7,200 sq. ft.	SFR-Basic
04 109984 RK	R-7,200	Residential 7,200 sq. ft.	SFR-Basic
04 120635 RK	R-5	Rural-5 Acre	Single Family Res-Combo
04 120468 RK	R-5	Rural-5 Acre	Single Family Res-Combo
04 109578 RK	R-7,200	Residential 7,200 sq. ft.	SFR-Basic
04 109997 RK	R-7,200	Residential 7,200 sq. ft.	SFR-Basic
04 118029 RK	R-5	Rural-5 Acre	Single Family Res-Combo
04 100249 RK	CITY	City	Single Family Res-Combo
04 114966 RK	CITY	City	Single Family Res-Combo
04 114968 RK	CITY	City	SFR-Basic
04 114970 RK	CITY	City	SFR-Basic
04 110589 RK	CITY	City	Single Family Res-Combo
04 110890 RK	CITY	City	SFR-Basic
04 114973 RK	CITY	City	SFR-Basic
04 114972 RK	CITY	City	SFR-Basic
04 115319 RK	CITY	City	Single Family Res-Combo
04 114975 RK	CITY	City	SFR-Basic
04 112447 RK	CITY	City	SFR-Basic
04 114974 RK	CITY	City	SFR-Basic
04 111478 RK	CITY	City	SFR-Basic
04 114977 RK	CITY	City	SFR-Basic
04 114978 RK	CITY	City	SFR-Basic
04 110318 RK	CITY	City	SFR-Basic
04 110314 RK	CITY	City	SFR-Basic

Accessory Dwelling Units

Index # - File Name: 1.0022 - Single Family Dwellings Data\_Snohomish County.pdf

04 114979 RK	CITY	City	SFR-Basic
04 110251 RK	CITY	City	SFR-Basic
04 114980 RK	CITY	City	SFR-Basic
04 110584 RK	CITY	City	Single Family Res-Combo
04 111477 RK	CITY	City	SFR-Basic
04 108498 RK	CITY	City	Single Family Res-Combo
04 114981 RK	CITY	City	SFR-Basic
04 114982 RK	CITY	City	SFR-Basic
04 114983 RK	CITY	City	SFR-Basic
04 111476 RK	CITY	City	SFR-Basic
04 110255 RK	CITY	City	SFR-Basic
04 114984 RK	CITY	City	SFR-Basic
04 100248 RK	CITY	City	Single Family Res-Combo
04 100245 RK	CITY	City	Single Family Res-Combo
04 108499 RK	CITY	City	Single Family Res-Combo
04 100246 RK	CITY	City	Single Family Res-Combo
04 110598 RK	CITY	City	SFR-Basic
04 110958 RK	R-7,200	Residential 7,200 sq. ft.	SFR-Basic
04 110962 RK	R-7,200	Residential 7,200 sq. ft.	SFR-Basic
04 110959 RK	R-7,200	Residential 7,200 sq. ft.	SFR-Basic
04 110964 RK	R-7,200	Residential 7,200 sq. ft.	SFR-Basic
04 108535 RK	R-7,200	Residential 7,200 sq. ft.	Single Family Res-Combo
04 112098 RK	R-7,200	Residential 7,200 sq. ft.	SFR-Basic
04 109357 RK	R-7,200	Residential 7,200 sq. ft.	SFR-Basic
04 110541 RK	R-7,200	Residential 7,200 sq. ft.	SFR-Basic
04 108887 RK	R-7,200	Residential 7,200 sq. ft.	Single Family Res-Combo
04 108886 RK	R-7,200	Residential 7,200 sq. ft.	Single Family Res-Combo
04 111823 RK	R-7,200	Residential 7,200 sq. ft.	SFR-Basic
04 112099 RK	R-7,200	Residential 7,200 sq. ft.	SFR-Basic
04 109570 RK	R-7,200	Residential 7,200 sq. ft.	SFR-Basic
04 109574 RK	R-7,200	Residential 7,200 sq. ft.	SFR-Basic
04 109982 RK	R-7,200	Residential 7,200 sq. ft.	SFR-Basic
04 110357 RK	R-7,200	Residential 7,200 sq. ft.	SFR-Basic
04 110354 RK	R-7,200	Residential 7,200 sq. ft.	SFR-Basic
04 109870 RK	R-7,200	Residential 7,200 sq. ft.	Single Family Res-Combo
04 109872 RK	R-7,200	Residential 7,200 sq. ft.	Single Family Res-Combo
04 109579 RK	R-7,200	Residential 7,200 sq. ft.	SFR-Basic
04 109581 RK	R-7,200	Residential 7,200 sq. ft.	Single Family Res-Combo
04 100283 RK	PRD-7,200	Residential 7,200 sq. ft.	SFR-Basic
03 111001 RK	PRD-7,200	Residential 7,200 sq. ft.	SFR-Basic
03 110999 RK	PRD-7,200	Residential 7,200 sq. ft.	SFR-Basic
04 100281 RK	PRD-7,200	Residential 7,200 sq. ft.	SFR-Basic
04 100279 RK	PRD-7,200	Residential 7,200 sq. ft.	SFR-Basic
04 100276 RK	PRD-7,200	Residential 7,200 sq. ft.	SFR-Basic
04 100271 RK	PRD-7,200	Residential 7,200 sq. ft.	SFR-Basic
04 100275 RK	PRD-7,200	Residential 7,200 sq. ft.	SFR-Basic
04 100284 RK	PRD-7,200	Residential 7,200 sq. ft.	SFR-Basic

Accessory Dwelling Units

Index # - File Name: 1.0022 - Single Family Dwellings Data\_Snohomish County.pdf

04 100277 RK	PRD-7,200	Residential 7,200 sq. ft.	SFR-Basic
04 100280 RK	PRD-7,200	Residential 7,200 sq. ft.	SFR-Basic
03 111028 RK	PRD-7,200	Residential 7,200 sq. ft.	Single Family Res-Combo
03 107733 RK	PRD-7,200	Residential 7,200 sq. ft.	Single Family Res-Combo
03 108857 RK	PRD-7,200	Residential 7,200 sq. ft.	Single Family Res-Combo
04 100270 RK	PRD-7,200	Residential 7,200 sq. ft.	SFR-Basic
04 109445 RK	R-7,200	Residential 7,200 sq. ft.	Single Family Res-Combo
04 110201 RK	R-7,200	Residential 7,200 sq. ft.	Single Family Res-Combo
04 115165 RK	R-7,200	Residential 7,200 sq. ft.	Single Family Res-Combo
04 110199 RK	R-7,200	Residential 7,200 sq. ft.	Single Family Res-Combo
04 110200 RK	R-7,200	Residential 7,200 sq. ft.	Single Family Res-Combo
04 115168 RK	R-7,200	Residential 7,200 sq. ft.	Single Family Res-Combo
04 113993 RK	R-7,200	Residential 7,200 sq. ft.	SFR-Basic
04 109447 RK	R-7,200	Residential 7,200 sq. ft.	Single Family Res-Combo
04 109571 RK	R-7,200	Residential 7,200 sq. ft.	SFR-Basic
03 110959 RK	R-7,200	Residential 7,200 sq. ft.	Single Family Res-Combo
03 111064 RK	R-7,200	Residential 7,200 sq. ft.	Single Family Res-Combo
04 108888 RK	R-7,200	Residential 7,200 sq. ft.	Single Family Res-Combo
03 110960 RK	R-7,200	Residential 7,200 sq. ft.	Single Family Res-Combo
04 110546 RK	R-7,200	Residential 7,200 sq. ft.	SFR-Basic
04 108718 RK	R-7,200	Residential 7,200 sq. ft.	SFR-Basic
03 110958 RK	R-7,200	Residential 7,200 sq. ft.	Single Family Res-Combo
04 108533 RK	R-7,200	Residential 7,200 sq. ft.	Single Family Res-Combo
04 108746 RK	R-7,200	Residential 7,200 sq. ft.	SFR-Basic
04 111465 RK	R-7,200	Residential 7,200 sq. ft.	SFR-Basic
03 111090 RK	R-7,200	Residential 7,200 sq. ft.	Single Family Res-Combo
04 110543 RK	R-7,200	Residential 7,200 sq. ft.	SFR-Basic
04 108534 RK	R-7,200	Residential 7,200 sq. ft.	Single Family Res-Combo
04 113994 RK	R-7,200	Residential 7,200 sq. ft.	Single Family Res-Combo
04 113428 RK	R-7,200	Residential 7,200 sq. ft.	Single Family Res-Combo
04 112119 RK	R-7,200	Residential 7,200 sq. ft.	SFR-Basic
03 111091 RK	R-7,200	Residential 7,200 sq. ft.	Single Family Res-Combo
04 108720 RK	R-7,200	Residential 7,200 sq. ft.	SFR-Basic
04 111457 RK	R-7,200	Residential 7,200 sq. ft.	SFR-Basic
04 108745 RK	R-7,200	Residential 7,200 sq. ft.	SFR-Basic
04 112118 RK	R-7,200	Residential 7,200 sq. ft.	SFR-Basic
04 112095 RK	R-7,200	Residential 7,200 sq. ft.	Single Family Res-Combo
04 113433 RK	R-7,200	Residential 7,200 sq. ft.	SFR-Basic
04 111821 RK	R-7,200	Residential 7,200 sq. ft.	SFR-Basic
04 109471 RK	R-7,200	Residential 7,200 sq. ft.	SFR-Basic
04 113429 RK	R-7,200	Residential 7,200 sq. ft.	SFR-Basic
04 113430 RK	R-7,200	Residential 7,200 sq. ft.	SFR-Basic
04 113431 RK	R-7,200	Residential 7,200 sq. ft.	SFR-Basic
04 109944 RK	R-7,200	Residential 7,200 sq. ft.	Single Family Res-Combo
04 110050 RK	R-7,200	Residential 7,200 sq. ft.	Single Family Res-Combo
04 109476 RK	R-7,200	Residential 7,200 sq. ft.	SFR-Basic
04 112123 RK	R-7,200	Residential 7,200 sq. ft.	Single Family Res-Combo

Accessory Dwelling Units

Index # - File Name: 1.0022 - Single Family Dwellings Data\_Snohomish County.pdf

04 110047 RK	R-7,200	Residential 7,200 sq. ft.	SFR-Basic
04 112431 RK	R-7,200	Residential 7,200 sq. ft.	SFR-Basic
04 110048 RK	R-7,200	Residential 7,200 sq. ft.	SFR-Basic
04 112432 RK	R-7,200	Residential 7,200 sq. ft.	SFR-Basic
04 112126 RK	R-7,200	Residential 7,200 sq. ft.	SFR-Basic
04 112433 RK	R-7,200	Residential 7,200 sq. ft.	Single Family Res-Combo
04 118026 RK	R-5	Rural-5 Acre	Single Family Res-Combo
04 118027 RK	R-5	Rural-5 Acre	Single Family Res-Combo
04 115436 RK	PRD-7,200	Residential 7,200 sq. ft.	Single Family Res-Combo
04 116291 RK	PRD-7,200	Residential 7,200 sq. ft.	Single Family Res-Combo
04 111264 RK	PRD-7,200	Residential 7,200 sq. ft.	SFR-Basic
04 114241 RK	PRD-7,200	Residential 7,200 sq. ft.	Single Family Res-Combo
04 111167 RK	PRD-7,200	Residential 7,200 sq. ft.	Single Family Res-Combo
04 113421 RK	PRD-7,200	Residential 7,200 sq. ft.	Single Family Res-Combo
04 115428 RK	PRD-7,200	Residential 7,200 sq. ft.	Single Family Res-Combo
04 115214 RK	PRD-7,200	Residential 7,200 sq. ft.	Single Family Res-Combo
04 115430 RK	PRD-7,200	Residential 7,200 sq. ft.	Single Family Res-Combo
04 116290 RK	PRD-7,200	Residential 7,200 sq. ft.	Single Family Res-Combo
04 113424 RK	PRD-7,200	Residential 7,200 sq. ft.	Single Family Res-Combo
04 111697 RK	PRD-7,200	Residential 7,200 sq. ft.	SFR-Basic
04 109263 RK	PRD-7,200	Residential 7,200 sq. ft.	Single Family Res-Combo
04 109271 RK	PRD-7,200	Residential 7,200 sq. ft.	Single Family Res-Combo
04 110108 RK	PRD-7,200	Residential 7,200 sq. ft.	Single Family Res-Combo
04 110109 RK	PRD-7,200	Residential 7,200 sq. ft.	Single Family Res-Combo
04 109269 RK	PRD-7,200	Residential 7,200 sq. ft.	Single Family Res-Combo
04 111311 RK	PRD-7,200	Residential 7,200 sq. ft.	SFR-Basic
04 100278 RK	PRD-7,200	Residential 7,200 sq. ft.	SFR-Basic
04 108511 RK	CITY	City	Single Family Res-Combo
04 110386 MH	R-9,600	Residential 9,600 sq. ft.	Triple Wide
04 115227 RK	PRD-9,600	Residential 9,600 sq. ft.	Single Family Res-Combo
04 120523 RK	PRD-9,600	Residential 9,600 sq. ft.	Single Family Res-Combo
04 115236 RK	PRD-9,600	Residential 9,600 sq. ft.	Single Family Res-Combo
04 115235 RK	PRD-9,600	Residential 9,600 sq. ft.	Single Family Res-Combo
04 115223 RK	PRD-9,600	Residential 9,600 sq. ft.	Single Family Res-Combo
04 120057 RK	PRD-9,600	Residential 9,600 sq. ft.	Single Family Res-Combo
04 115231 RK	PRD-9,600	Residential 9,600 sq. ft.	Single Family Res-Combo
04 115425 RK	PRD-9,600	Residential 9,600 sq. ft.	Single Family Res-Combo
04 115434 RK	PRD-9,600	Residential 9,600 sq. ft.	Single Family Res-Combo
04 120053 RK	PRD-9,600	Residential 9,600 sq. ft.	Single Family Res-Combo
03 110580 RK	R-5	Rural-5 Acre	SFR-Basic
03 110581 RK	R-5	Rural-5 Acre	SFR-Basic
04 113316 RK	R-5	Rural-5 Acre	Single Family Res-Combo
04 108840 RK	R-5	Rural-5 Acre	Single Family Res-Combo
04 109157 RK	R-5	Rural-5 Acre	SFR-Basic
04 109354 RK	R-5	Rural-5 Acre	SFR-Basic
04 110103 RK	R-5	Rural-5 Acre	SFR-Basic
04 112031 RK	R-5	Rural-5 Acre	SFR-Basic

Accessory Dwelling Units

Index # - File Name: 1.0022 - Single Family Dwellings Data\_Snohomish County.pdf

04 110107 RK	R-5	Rural-5 Acre	SFR-Basic
04 113684 RK	R-5	Rural-5 Acre	SFR-Basic
04 112884 RK	LDMR	Low Density Multiple Reside	SFR-Basic
04 113304 RK	LDMR	Low Density Multiple Reside	SFR-Basic
04 114646 RK	LDMR	Low Density Multiple Reside	SFR-Basic
04 113305 RK	LDMR	Low Density Multiple Reside	SFR-Basic
04 114650 RK	LDMR	Low Density Multiple Reside	SFR-Basic
04 115877 RK	LDMR	Low Density Multiple Reside	SFR-Basic
04 114642 RK	LDMR	Low Density Multiple Reside	SFR-Basic
04 114652 RK	LDMR	Low Density Multiple Reside	SFR-Basic
04 114651 RK	LDMR	Low Density Multiple Reside	SFR-Basic
04 117527 RK	LDMR	Low Density Multiple Reside	SFR-Basic
04 116066 RK	LDMR	Low Density Multiple Reside	SFR-Basic
04 116069 RK	LDMR	Low Density Multiple Reside	Single Family Res-Combo
04 116238 RK	LDMR	Low Density Multiple Reside	SFR-Basic
04 116834 RK	LDMR	Low Density Multiple Reside	SFR-Basic
04 116836 RK	LDMR	Low Density Multiple Reside	SFR-Basic
04 116837 RK	LDMR	Low Density Multiple Reside	SFR-Basic
04 117535 RK	LDMR	Low Density Multiple Reside	SFR-Basic
04 118479 RK	LDMR	Low Density Multiple Reside	SFR-Basic
04 114645 RK	LDMR	Low Density Multiple Reside	SFR-Basic
04 112887 RK	LDMR	Low Density Multiple Reside	SFR-Basic
04 112889 RK	LDMR	Low Density Multiple Reside	SFR-Basic
04 109399 RK	LDMR	Low Density Multiple Reside	Single Family Res-Combo
04 109400 RK	LDMR	Low Density Multiple Reside	Single Family Res-Combo
04 111881 RK	LDMR	Low Density Multiple Reside	SFR-Basic
04 108995 RK	LDMR	Low Density Multiple Reside	Single Family Res-Combo
04 108996 RK	LDMR	Low Density Multiple Reside	Single Family Res-Combo
03 110912 RK	R-7,200	Residential 7,200 sq. ft.	Single Family Res-Combo
04 108955 RK	CITY	City	Single Family Res-Combo
04 109300 RK	CITY	City	Single Family Res-Combo
04 109302 RK	CITY	City	Single Family Res-Combo
04 109304 RK	CITY	City	Single Family Res-Combo
04 109305 RK	CITY	City	Single Family Res-Combo
04 109303 RK	CITY	City	Single Family Res-Combo
04 110105 RK	CITY	City	Single Family Res-Combo
04 110104 RK	CITY	City	Single Family Res-Combo
04 110102 RK	CITY	City	Single Family Res-Combo
04 111558 RK	CITY	City	Single Family Res-Combo
03 104698 RK	CITY	City	Single Family Res-Combo
04 112292 RK	CITY	City	Single Family Res-Combo
04 112986 RK	CITY	City	Single Family Res-Combo
04 112300 RK	CITY	City	Single Family Res-Combo
04 112985 RK	CITY	City	Single Family Res-Combo
04 114753 RK	CITY	City	Single Family Res-Combo
04 113879 RK	CITY	City	Single Family Res-Combo
04 115023 RK	CITY	City	Single Family Res-Combo

Accessory Dwelling Units

Index # - File Name: 1.0022 - Single Family Dwellings Data\_Snohomish County.pdf

04 115092 RK	CITY	City	Single Family Res-Combo
04 114755 RK	CITY	City	Single Family Res-Combo
04 115100 RK	CITY	City	Single Family Res-Combo
04 114040 RK	CITY	City	Single Family Res-Combo
04 113880 RK	CITY	City	Single Family Res-Combo
04 113884 RK	CITY	City	Single Family Res-Combo
04 113882 RK	CITY	City	Single Family Res-Combo
04 114041 RK	CITY	City	Single Family Res-Combo
04 113290 RK	CITY	City	Single Family Res-Combo
04 113700 RK	CITY	City	Single Family Res-Combo
04 113704 RK	CITY	City	Single Family Res-Combo
04 113291 RK	CITY	City	Single Family Res-Combo
04 113292 RK	CITY	City	Single Family Res-Combo
04 113294 RK	CITY	City	Single Family Res-Combo
04 115094 RK	CITY	City	Single Family Res-Combo
04 115099 RK	CITY	City	Single Family Res-Combo
04 115096 RK	CITY	City	Single Family Res-Combo
04 115234 RK	CITY	City	Single Family Res-Combo
04 113701 RK	CITY	City	Single Family Res-Combo
04 113881 RK	CITY	City	Single Family Res-Combo
04 114043 RK	CITY	City	Single Family Res-Combo
04 113702 RK	CITY	City	Single Family Res-Combo
04 112297 RK	CITY	City	Single Family Res-Combo
04 113289 RK	CITY	City	Single Family Res-Combo
04 112295 RK	CITY	City	Single Family Res-Combo
04 112988 RK	CITY	City	Single Family Res-Combo
04 112990 RK	CITY	City	Single Family Res-Combo
04 112299 RK	CITY	City	Single Family Res-Combo
04 110629 RK	CITY	City	Single Family Res-Combo
04 111000 RK	CITY	City	Single Family Res-Combo
04 111003 RK	CITY	City	Single Family Res-Combo
04 112983 RK	CITY	City	Single Family Res-Combo
04 112987 RK	CITY	City	Single Family Res-Combo
03 101938 RK	CITY	City	Single Family Res-Combo
04 115021 RK	CITY	City	Single Family Res-Combo
04 114685 RK	CITY	City	Single Family Res-Combo
04 114682 RK	CITY	City	Single Family Res-Combo
04 115019 RK	CITY	City	Single Family Res-Combo
04 115101 RK	CITY	City	Single Family Res-Combo
04 109206 RK	PRD-9,600	Residential 9,600 sq. ft.	SFR-Basic
03 107921 RK	PRD-9,600	Residential 9,600 sq. ft.	Single Family Res-Combo
04 109000 RK	PRD-9,600	Residential 9,600 sq. ft.	SFR-Basic
04 108602 RK	PRD-9,600	Residential 9,600 sq. ft.	Single Family Res-Combo
03 107924 RK	PRD-9,600	Residential 9,600 sq. ft.	Single Family Res-Combo
04 108839 RK	PRD-7,200	Residential 7,200 sq. ft.	Single Family Res-Combo
03 110967 RK	PRD-7,200	Residential 7,200 sq. ft.	Single Family Res-Combo
04 108730 RK	PRD-7,200	Residential 7,200 sq. ft.	Single Family Res-Combo

Accessory Dwelling Units

Index # - File Name: 1.0022 - Single Family Dwellings Data\_Snohomish County.pdf

04 110198 RK	PRD-7,200	Residential 7,200 sq. ft.	SFR-Basic
03 110909 RK	PRD-7,200	Residential 7,200 sq. ft.	Single Family Res-Combo
04 108727 RK	PRD-7,200	Residential 7,200 sq. ft.	Single Family Res-Combo
04 111067 RK	PRD-7,200	Residential 7,200 sq. ft.	SFR-Basic
03 111030 RK	PRD-7,200	Residential 7,200 sq. ft.	Single Family Res-Combo
04 111064 RK	PRD-7,200	Residential 7,200 sq. ft.	SFR-Basic
04 113016 RK	PRD-7,200	Residential 7,200 sq. ft.	SFR-Basic
04 100158 RK	PRD-7,200	Residential 7,200 sq. ft.	Single Family Res-Combo
04 113020 RK	PRD-7,200	Residential 7,200 sq. ft.	SFR-Basic
04 113025 RK	PRD-7,200	Residential 7,200 sq. ft.	SFR-Basic
04 113027 RK	PRD-7,200	Residential 7,200 sq. ft.	SFR-Basic
04 113022 RK	PRD-7,200	Residential 7,200 sq. ft.	SFR-Basic
03 111029 RK	PRD-7,200	Residential 7,200 sq. ft.	Single Family Res-Combo
04 111857 RK	PRD-7,200	Residential 7,200 sq. ft.	SFR-Basic
04 111858 RK	PRD-7,200	Residential 7,200 sq. ft.	SFR-Basic
04 108838 RK	PRD-7,200	Residential 7,200 sq. ft.	Single Family Res-Combo
04 113100 RK	PRD-9,600	Residential 9,600 sq. ft.	SFR-Basic
04 114597 RK	PRD-9,600	Residential 9,600 sq. ft.	SFR-Basic
04 113101 RK	PRD-9,600	Residential 9,600 sq. ft.	SFR-Basic
04 115284 RK	PRD-9,600	Residential 9,600 sq. ft.	SFR-Basic
04 114599 RK	PRD-9,600	Residential 9,600 sq. ft.	SFR-Basic
04 113103 RK	PRD-9,600	Residential 9,600 sq. ft.	SFR-Basic
04 112417 RK	PRD-9,600	Residential 9,600 sq. ft.	SFR-Basic
04 113751 RK	PRD-9,600	Residential 9,600 sq. ft.	SFR-Basic
04 115286 RK	PRD-9,600	Residential 9,600 sq. ft.	SFR-Basic
04 113104 RK	PRD-9,600	Residential 9,600 sq. ft.	SFR-Basic
04 113105 RK	PRD-9,600	Residential 9,600 sq. ft.	SFR-Basic
04 115287 RK	PRD-9,600	Residential 9,600 sq. ft.	SFR-Basic
04 113106 RK	PRD-9,600	Residential 9,600 sq. ft.	SFR-Basic
04 113108 RK	PRD-9,600	Residential 9,600 sq. ft.	SFR-Basic
04 114601 RK	PRD-9,600	Residential 9,600 sq. ft.	SFR-Basic
04 114596 RK	PRD-9,600	Residential 9,600 sq. ft.	SFR-Basic
04 113750 RK	PRD-9,600	Residential 9,600 sq. ft.	SFR-Basic
04 112019 RK	PRD-9,600	Residential 9,600 sq. ft.	SFR-Basic
04 108655 RK	PRD-9,600	Residential 9,600 sq. ft.	SFR-Basic
04 109170 RK	PRD-9,600	Residential 9,600 sq. ft.	SFR-Basic
04 108656 RK	PRD-9,600	Residential 9,600 sq. ft.	SFR-Basic
04 108657 RK	PRD-9,600	Residential 9,600 sq. ft.	SFR-Basic
04 111358 RK	PRD-9,600	Residential 9,600 sq. ft.	SFR-Basic
04 111357 RK	PRD-9,600	Residential 9,600 sq. ft.	SFR-Basic
03 111042 RK	PRD-9,600	Residential 9,600 sq. ft.	SFR-Basic
04 113112 RK	PRD-9,600	Residential 9,600 sq. ft.	SFR-Basic
03 111044 RK	PRD-9,600	Residential 9,600 sq. ft.	SFR-Basic
04 110846 RK	PRD-9,600	Residential 9,600 sq. ft.	SFR-Basic
03 111041 RK	PRD-9,600	Residential 9,600 sq. ft.	SFR-Basic
04 111359 RK	PRD-9,600	Residential 9,600 sq. ft.	SFR-Basic
04 109171 RK	PRD-9,600	Residential 9,600 sq. ft.	SFR-Basic

Accessory Dwelling Units

Index # - File Name: 1.0022 - Single Family Dwellings Data\_Snohomish County.pdf

04 111356 RK	PRD-9,600	Residential 9,600 sq. ft.	SFR-Basic
03 111043 RK	PRD-9,600	Residential 9,600 sq. ft.	SFR-Basic
04 111360 RK	PRD-9,600	Residential 9,600 sq. ft.	SFR-Basic
04 111362 RK	PRD-9,600	Residential 9,600 sq. ft.	SFR-Basic
04 109701 RK	PRD-9,600	Residential 9,600 sq. ft.	SFR-Basic
04 117915 RK	R-7,200	Residential 7,200 sq. ft.	SFR-Basic
04 117916 RK	R-7,200	Residential 7,200 sq. ft.	SFR-Basic
03 110277 RK	R-7,200	Residential 7,200 sq. ft.	SFR-Basic
04 113955 RK	R-7,200	Residential 7,200 sq. ft.	SFR-Basic
03 110278 RK	R-7,200	Residential 7,200 sq. ft.	Single Family Res-Combo
03 110276 RK	R-7,200	Residential 7,200 sq. ft.	Single Family Res-Combo
04 112016 RK	PRD-9,600	Residential 9,600 sq. ft.	SFR-Basic
04 112416 RK	PRD-9,600	Residential 9,600 sq. ft.	SFR-Basic
04 112017 RK	PRD-9,600	Residential 9,600 sq. ft.	SFR-Basic
04 112018 RK	PRD-9,600	Residential 9,600 sq. ft.	SFR-Basic
04 113466 RK	R-7,200	Residential 7,200 sq. ft.	SFR-Basic
03 109321 MH	R-5	Rural-5 Acre	Double Wide
03 107440 RK	R-5	Rural-5 Acre	Single Family Res-Combo
03 109430 RK	R-5	Rural-5 Acre	Single Family Res-Combo
03 109430 001 00 RK	R-5	Rural-5 Acre	Single Family Res-Combo
04 115200 RK	R-7,200	Residential 7,200 sq. ft.	SFR-Basic
04 108509 RK	R-5	Rural-5 Acre	Single Family Res-Combo
04 109310 RK	R-5	Rural-5 Acre	Single Family Res-Combo
04 109307 MH	R-5	Rural-5 Acre	Double Wide
04 117145 RK	R-7,200	Residential 7,200 sq. ft.	SFR-Basic
03 110275 RK	R-7,200	Residential 7,200 sq. ft.	Single Family Res-Combo
03 110669 RK	R-7,200	Residential 7,200 sq. ft.	Single Family Res-Combo
04 115201 RK	R-7,200	Residential 7,200 sq. ft.	SFR-Basic
04 113953 RK	R-7,200	Residential 7,200 sq. ft.	SFR-Basic
04 121268 RK	R-7,200	Residential 7,200 sq. ft.	SFR-Basic
04 120157 RK	R-7,200	Residential 7,200 sq. ft.	SFR-Basic
04 120158 RK	R-7,200	Residential 7,200 sq. ft.	SFR-Basic
04 119042 RK	R-7,200	Residential 7,200 sq. ft.	SFR-Basic
04 119043 RK	R-7,200	Residential 7,200 sq. ft.	SFR-Basic
04 100013 RK	RRT-10	Rural Resource Transition-10	Single Family Res-Combo
04 116733 RK	R-7,200	Residential 7,200 sq. ft.	Single Family Res-Combo
04 108735 RK	R-7,200	Residential 7,200 sq. ft.	SFR-Basic
03 109296 RK	R-7,200	Residential 7,200 sq. ft.	Single Family Res-Combo
04 112289 RK	R-7,200	Residential 7,200 sq. ft.	SFR-Basic
04 113462 RK	R-7,200	Residential 7,200 sq. ft.	SFR-Basic
04 108732 RK	R-7,200	Residential 7,200 sq. ft.	SFR-Basic
04 115863 RK	R-7,200	Residential 7,200 sq. ft.	SFR-Basic
04 115862 RK	R-7,200	Residential 7,200 sq. ft.	SFR-Basic
04 113551 RK	R-7,200	Residential 7,200 sq. ft.	Single Family Res-Combo
04 115856 RK	R-7,200	Residential 7,200 sq. ft.	Single Family Res-Combo
04 115850 RK	R-7,200	Residential 7,200 sq. ft.	Single Family Res-Combo
04 116737 RK	R-7,200	Residential 7,200 sq. ft.	Single Family Res-Combo



Accessory Dwelling Units

Index # - File Name: 1.0022 - Single Family Dwellings Data\_Snohomish County.pdf

04 115865 RK	R-7,200	Residential 7,200 sq. ft.	SFR-Basic
04 113144 RK	R-7,200	Residential 7,200 sq. ft.	SFR-Basic
04 117594 RK	R-7,200	Residential 7,200 sq. ft.	SFR-Basic
04 113143 RK	R-7,200	Residential 7,200 sq. ft.	SFR-Basic
03 108989 RK	R-5	Rural-5 Acre	Single Family Res-Combo
04 100148 RK	R-5	Rural-5 Acre	Single Family Res-Combo
04 110587 RK	R-5	Rural-5 Acre	Single Family Res-Combo
04 117563 RK	R-5	Rural-5 Acre	Single Family Res-Combo
04 109083 RK	R-5	Rural-5 Acre	Single Family Res-Combo
04 115193 RK	R-5	Rural-5 Acre	Single Family Res-Combo
04 109193 RK	R-5	Rural-5 Acre	SFR-Basic
04 109416 RK	R-9,600	Residential 9,600 sq. ft.	Single Family Res-Combo
04 112045 RK	R-9,600	Residential 9,600 sq. ft.	SFR-Basic
04 116456 RK	R-9,600	Residential 9,600 sq. ft.	SFR-Basic
04 118309 RK	R-9,600	Residential 9,600 sq. ft.	Single Family Res-Combo
04 110999 RK	R-9,600	Residential 9,600 sq. ft.	Single Family Res-Combo
04 114517 RK	R-9,600	Residential 9,600 sq. ft.	SFR-Basic
04 115301 RK	R-9,600	Residential 9,600 sq. ft.	Single Family Res-Combo
04 114952 RK	R-5	Rural-5 Acre	Single Family Res-Combo
04 112398 RK	R-5	Rural-5 Acre	Single Family Res-Combo
04 112524 RK	UC	Urban Center	SFR-Basic
04 111408 RK	R-5	Rural-5 Acre	Single Family Res-Combo
04 109824 RK	R-5	Rural-5 Acre	Single Family Res-Combo
04 109869 RK	R-5	Rural-5 Acre	Single Family Res-Combo
04 109926 MH	R-9,600	Residential 9,600 sq. ft.	Double Wide
04 110084 RK	R-5	Rural-5 Acre	Single Family Res-Combo
04 112165 RK	R-8,400	Residential 8,400 sq. ft.	Single Family Res-Combo
04 121391 RK	R-7,200	Residential 7,200 sq. ft.	SFR-Basic
04 119221 RK	R-7,200	Residential 7,200 sq. ft.	SFR-Basic
04 121559 RK	R-7,200	Residential 7,200 sq. ft.	SFR-Basic
04 117441 RK	R-7,200	Residential 7,200 sq. ft.	SFR-Basic
04 117963 RK	R-7,200	Residential 7,200 sq. ft.	SFR-Basic
04 117256 RK	R-7,200	Residential 7,200 sq. ft.	SFR-Basic
04 118612 RK	R-7,200	Residential 7,200 sq. ft.	SFR-Basic
04 119218 RK	R-7,200	Residential 7,200 sq. ft.	SFR-Basic
04 117259 RK	R-7,200	Residential 7,200 sq. ft.	SFR-Basic
04 116859 RK	R-7,200	Residential 7,200 sq. ft.	SFR-Basic
04 118427 RK	R-7,200	Residential 7,200 sq. ft.	SFR-Basic
04 119223 RK	R-7,200	Residential 7,200 sq. ft.	SFR-Basic
04 114465 RK	R-7,200	Residential 7,200 sq. ft.	SFR-Basic
04 113957 RK	R-7,200	Residential 7,200 sq. ft.	SFR-Basic
04 116506 RK	R-7,200	Residential 7,200 sq. ft.	SFR-Basic
03 103142 RK	R-7,200	Residential 7,200 sq. ft.	Single Family Res-Combo
04 115887 RK	R-7,200	Residential 7,200 sq. ft.	SFR-Basic
04 116518 RK	R-7,200	Residential 7,200 sq. ft.	SFR-Basic
04 114779 RK	R-7,200	Residential 7,200 sq. ft.	SFR-Basic
03 108021 RK	R-7,200	Residential 7,200 sq. ft.	Single Family Res-Combo

Accessory Dwelling Units

Index # - File Name: 1.0022 - Single Family Dwellings Data\_Snohomish County.pdf

03 107788 RK	R-7,200	Residential 7,200 sq. ft.	Single Family Res-Combo
03 103954 RK	R-7,200	Residential 7,200 sq. ft.	Single Family Res-Combo
03 103152 RK	R-7,200	Residential 7,200 sq. ft.	Single Family Res-Combo
03 107996 RK	R-7,200	Residential 7,200 sq. ft.	Single Family Res-Combo
04 114475 RK	R-7,200	Residential 7,200 sq. ft.	SFR-Basic
04 115182 RK	R-7,200	Residential 7,200 sq. ft.	SFR-Basic
04 115183 RK	R-7,200	Residential 7,200 sq. ft.	SFR-Basic
04 116511 RK	R-7,200	Residential 7,200 sq. ft.	SFR-Basic
04 116855 RK	R-7,200	Residential 7,200 sq. ft.	SFR-Basic
04 114781 RK	R-7,200	Residential 7,200 sq. ft.	SFR-Basic
04 119799 RK	R-7,200	Residential 7,200 sq. ft.	SFR-Basic
04 119015 RK	R-7,200	Residential 7,200 sq. ft.	SFR-Basic
04 114876 RK	RC	Rural Conservation	Single Family Res-Combo
04 110646 RK	R-5	Rural-5 Acre	Single Family Res-Combo
04 116861 RK	R-7,200	Residential 7,200 sq. ft.	SFR-Basic
04 118609 RK	R-7,200	Residential 7,200 sq. ft.	SFR-Basic
04 121389 RK	R-7,200	Residential 7,200 sq. ft.	SFR-Basic
04 118424 RK	R-7,200	Residential 7,200 sq. ft.	SFR-Basic
04 117221 RK	R-7,200	Residential 7,200 sq. ft.	SFR-Basic
04 119216 RK	R-7,200	Residential 7,200 sq. ft.	SFR-Basic
04 118606 RK	R-7,200	Residential 7,200 sq. ft.	SFR-Basic
04 114073 RK	R-7,200	Residential 7,200 sq. ft.	SFR-Basic
04 114074 RK	R-7,200	Residential 7,200 sq. ft.	SFR-Basic
04 109631 RK	R-7,200	Residential 7,200 sq. ft.	Single Family Res-Combo
04 114075 RK	R-7,200	Residential 7,200 sq. ft.	SFR-Basic
04 114078 RK	R-7,200	Residential 7,200 sq. ft.	SFR-Basic
04 112843 RK	R-7,200	Residential 7,200 sq. ft.	SFR-Basic
04 112841 RK	R-7,200	Residential 7,200 sq. ft.	SFR-Basic
04 109636 RK	R-7,200	Residential 7,200 sq. ft.	Single Family Res-Combo
04 112842 RK	R-7,200	Residential 7,200 sq. ft.	SFR-Basic
04 109634 RK	R-7,200	Residential 7,200 sq. ft.	Single Family Res-Combo
04 114520 RK	R-7,200	Residential 7,200 sq. ft.	SFR-Basic
04 109637 RK	R-7,200	Residential 7,200 sq. ft.	Single Family Res-Combo
04 114081 RK	R-7,200	Residential 7,200 sq. ft.	SFR-Basic
04 109638 RK	R-7,200	Residential 7,200 sq. ft.	Single Family Res-Combo
04 114082 RK	R-7,200	Residential 7,200 sq. ft.	SFR-Basic
04 110853 RK	F	Forestry	Single Family Res-Combo
04 113267 RK	CITY	City	SFR-Basic
04 111656 RK	CITY	City	SFR-Basic
04 111657 RK	CITY	City	SFR-Basic
04 113250 RK	CITY	City	SFR-Basic
04 113258 RK	CITY	City	SFR-Basic
04 113253 RK	CITY	City	SFR-Basic
04 113259 RK	CITY	City	SFR-Basic
04 113248 RK	CITY	City	SFR-Basic
04 113254 RK	CITY	City	SFR-Basic
04 114605 RK	CITY	City	SFR-Basic

Accessory Dwelling Units

Index # - File Name: 1.0022 - Single Family Dwellings Data\_Snohomish County.pdf

04 113268 RK	CITY	City	SFR-Basic
04 113261 RK	CITY	City	SFR-Basic
04 111658 RK	CITY	City	SFR-Basic
04 111659 RK	CITY	City	SFR-Basic
04 111660 RK	CITY	City	SFR-Basic
04 111661 RK	CITY	City	SFR-Basic
04 112950 RK	CITY	City	SFR-Basic
04 111662 RK	CITY	City	SFR-Basic
04 111663 RK	CITY	City	SFR-Basic
04 111665 RK	CITY	City	SFR-Basic
04 111666 RK	CITY	City	SFR-Basic
04 111667 RK	CITY	City	SFR-Basic
04 111668 RK	CITY	City	SFR-Basic
04 111669 RK	CITY	City	SFR-Basic
04 111670 RK	CITY	City	SFR-Basic
04 111671 RK	CITY	City	SFR-Basic
04 111683 RK	CITY	City	SFR-Basic
04 111672 RK	CITY	City	SFR-Basic
04 111673 RK	CITY	City	SFR-Basic
04 112949 RK	CITY	City	SFR-Basic
04 111674 RK	CITY	City	SFR-Basic
04 111684 RK	CITY	City	SFR-Basic
04 111676 RK	CITY	City	SFR-Basic
04 111677 RK	CITY	City	SFR-Basic
04 111678 RK	CITY	City	SFR-Basic
04 111685 RK	CITY	City	SFR-Basic
04 111679 RK	CITY	City	SFR-Basic
04 111680 RK	CITY	City	SFR-Basic
04 111681 RK	CITY	City	SFR-Basic
04 111682 RK	CITY	City	SFR-Basic
04 111686 RK	CITY	City	SFR-Basic
04 113257 RK	CITY	City	SFR-Basic
04 113270 RK	CITY	City	Single Family Res-Combo
04 113260 RK	CITY	City	SFR-Basic
04 113256 RK	CITY	City	SFR-Basic
04 113264 RK	CITY	City	SFR-Basic
04 113255 RK	CITY	City	SFR-Basic
04 113269 RK	CITY	City	Single Family Res-Combo
04 113265 RK	CITY	City	SFR-Basic
04 113251 RK	CITY	City	SFR-Basic
04 113266 RK	CITY	City	SFR-Basic
04 113246 RK	CITY	City	SFR-Basic
04 113252 RK	CITY	City	SFR-Basic
04 112184 RK	R-9,600	Residential 9,600 sq. ft.	SFR-Basic
04 112185 RK	R-9,600	Residential 9,600 sq. ft.	SFR-Basic
04 100226 RK	R-9,600	Residential 9,600 sq. ft.	Single Family Res-Combo
04 116081 RK	R-9,600	Residential 9,600 sq. ft.	SFR-Basic

Accessory Dwelling Units

Index # - File Name: 1.0022 - Single Family Dwellings Data\_Snohomish County.pdf

04 116082 RK	R-9,600	Residential 9,600 sq. ft.	SFR-Basic
04 113988 RK	R-9,600	Residential 9,600 sq. ft.	SFR-Basic
04 113986 RK	R-9,600	Residential 9,600 sq. ft.	SFR-Basic
04 113972 RK	R-9,600	Residential 9,600 sq. ft.	SFR-Basic
04 113985 RK	R-9,600	Residential 9,600 sq. ft.	SFR-Basic
04 113984 RK	R-9,600	Residential 9,600 sq. ft.	SFR-Basic
04 114709 RK	R-9,600	Residential 9,600 sq. ft.	SFR-Basic
04 114713 RK	R-9,600	Residential 9,600 sq. ft.	SFR-Basic
04 114714 RK	R-9,600	Residential 9,600 sq. ft.	SFR-Basic
04 111007 RK	R-5	Rural-5 Acre	Single Family Res-Combo
04 111068 RK	R-5	Rural-5 Acre	Single Family Res-Combo
04 111069 RK	R-5	Rural-5 Acre	Single Family Res-Combo
04 111148 RK	R-5	Rural-5 Acre	Single Family Res-Combo
04 111223 RK	CITY	City	SFR-Basic
04 111225 RK	CITY	City	SFR-Basic
04 111226 RK	CITY	City	SFR-Basic
04 111227 RK	CITY	City	SFR-Basic
04 111229 RK	CITY	City	SFR-Basic
04 111231 RK	CITY	City	SFR-Basic
04 111232 RK	CITY	City	SFR-Basic
04 111233 RK	CITY	City	SFR-Basic
04 111234 RK	CITY	City	SFR-Basic
04 111247 RK	MR	Multiple Residential	Duplex-Combo
04 111238 RK	MR	Multiple Residential	Duplex-Combo
04 111269 RK	R-5	Rural-5 Acre	Single Family Res-Combo
04 114715 RK	R-9,600	Residential 9,600 sq. ft.	SFR-Basic
03 108635 RK	R-9,600	Residential 9,600 sq. ft.	Single Family Res-Combo
04 112395 RK	R-9,600	Residential 9,600 sq. ft.	SFR-Basic
04 112393 RK	R-9,600	Residential 9,600 sq. ft.	SFR-Basic
04 112397 RK	R-9,600	Residential 9,600 sq. ft.	SFR-Basic
04 114716 RK	R-9,600	Residential 9,600 sq. ft.	SFR-Basic
04 113983 RK	R-9,600	Residential 9,600 sq. ft.	SFR-Basic
04 113975 RK	R-9,600	Residential 9,600 sq. ft.	SFR-Basic
04 113982 RK	R-9,600	Residential 9,600 sq. ft.	SFR-Basic
04 113976 RK	R-9,600	Residential 9,600 sq. ft.	SFR-Basic
04 113981 RK	R-9,600	Residential 9,600 sq. ft.	SFR-Basic
04 113979 RK	R-9,600	Residential 9,600 sq. ft.	SFR-Basic
03 109391 RK	R-9,600	Residential 9,600 sq. ft.	Single Family Res-Combo
04 112187 RK	R-9,600	Residential 9,600 sq. ft.	SFR-Basic
04 112188 RK	R-9,600	Residential 9,600 sq. ft.	SFR-Basic
04 112190 RK	R-9,600	Residential 9,600 sq. ft.	SFR-Basic
04 112191 RK	R-9,600	Residential 9,600 sq. ft.	SFR-Basic
04 112192 RK	R-9,600	Residential 9,600 sq. ft.	SFR-Basic
04 112193 RK	R-9,600	Residential 9,600 sq. ft.	SFR-Basic
04 118670 RK	R-9,600	Residential 9,600 sq. ft.	SFR-Basic
04 118569 RK	R-9,600	Residential 9,600 sq. ft.	SFR-Basic
04 118673 RK	R-9,600	Residential 9,600 sq. ft.	SFR-Basic

Accessory Dwelling Units

Index # - File Name: 1.0022 - Single Family Dwellings Data\_Snohomish County.pdf

04 118570 RK	R-9,600	Residential 9,600 sq. ft.	SFR-Basic
04 118674 RK	R-9,600	Residential 9,600 sq. ft.	SFR-Basic
04 118671 RK	R-9,600	Residential 9,600 sq. ft.	SFR-Basic
04 119228 RK	R-5	Rural-5 Acre	Single Family Res-Combo
04 109053 RK	R-7,200	Residential 7,200 sq. ft.	Duplex-Combo
04 110481 RK	R-9,600	Residential 9,600 sq. ft.	SFR-Basic
04 110482 RK	R-9,600	Residential 9,600 sq. ft.	SFR-Basic
04 110531 RK	R-5	Rural-5 Acre	Single Family Res-Combo
03 109605 RK	R-7,200	Residential 7,200 sq. ft.	Single Family Res-Combo
04 111525 RK	R-5	Rural-5 Acre	Single Family Res-Combo
04 111523 RK	R-5	Rural-5 Acre	SFR-Basic
04 114718 RK	R-9,600	Residential 9,600 sq. ft.	SFR-Basic
04 114719 RK	R-9,600	Residential 9,600 sq. ft.	SFR-Basic
04 114721 RK	R-9,600	Residential 9,600 sq. ft.	SFR-Basic
04 112194 RK	R-9,600	Residential 9,600 sq. ft.	SFR-Basic
04 112195 RK	R-9,600	Residential 9,600 sq. ft.	SFR-Basic
04 112196 RK	R-9,600	Residential 9,600 sq. ft.	SFR-Basic
04 112197 RK	R-9,600	Residential 9,600 sq. ft.	SFR-Basic
04 112198 RK	R-9,600	Residential 9,600 sq. ft.	SFR-Basic
04 112199 RK	R-9,600	Residential 9,600 sq. ft.	SFR-Basic
04 114625 RK	CITY	City	SFR-Basic
04 113714 RK	CITY	City	Single Family Res-Combo
04 117981 RK	CITY	City	Single Family Res-Combo
04 118030 RK	CITY	City	Duplex-Combo
03 110673 RK	R-7,200(PRD)	Residential 7,200 sq. ft.	Single Family Res-Combo
04 112608 RK	R-7,200(PRD)	Residential 7,200 sq. ft.	SFR-Basic
04 113952 RK	R-7,200(PRD)	Residential 7,200 sq. ft.	SFR-Basic
04 113950 RK	R-7,200(PRD)	Residential 7,200 sq. ft.	SFR-Basic
04 114901 RK	R-7,200(PRD)	Residential 7,200 sq. ft.	SFR-Basic
04 119393 RK	R-7,200(PRD)	Residential 7,200 sq. ft.	SFR-Basic
04 114905 RK	R-7,200(PRD)	Residential 7,200 sq. ft.	SFR-Basic
04 114904 RK	R-7,200(PRD)	Residential 7,200 sq. ft.	SFR-Basic
04 113489 RK	R-9,600	Residential 9,600 sq. ft.	SFR-Basic
04 113493 RK	R-9,600	Residential 9,600 sq. ft.	SFR-Basic
04 113495 RK	R-9,600	Residential 9,600 sq. ft.	SFR-Basic
04 114488 RK	R-9,600	Residential 9,600 sq. ft.	SFR-Basic
04 114492 RK	R-9,600	Residential 9,600 sq. ft.	SFR-Basic
03 110869 RK	R-9,600	Residential 9,600 sq. ft.	Single Family Res-Combo
04 113500 RK	R-9,600	Residential 9,600 sq. ft.	Single Family Res-Combo
04 114491 RK	R-9,600	Residential 9,600 sq. ft.	SFR-Basic
04 120683 RK	PRD-9,600	Residential 9,600 sq. ft.	SFR-Basic
04 115719 RK	PRD-9,600	Residential 9,600 sq. ft.	SFR-Basic
04 117138 RK	PRD-9,600	Residential 9,600 sq. ft.	SFR-Basic
04 120009 RK	PRD-9,600	Residential 9,600 sq. ft.	SFR-Basic
04 117554 RK	PRD-9,600	Residential 9,600 sq. ft.	SFR-Basic
04 116602 RK	PRD-9,600	Residential 9,600 sq. ft.	SFR-Basic
04 115718 RK	PRD-9,600	Residential 9,600 sq. ft.	SFR-Basic

Accessory Dwelling Units

Index # - File Name: 1.0022 - Single Family Dwellings Data\_Snohomish County.pdf

04 115252 RK	PRD-9,600	Residential 9,600 sq. ft.	SFR-Basic
04 115254 RK	PRD-9,600	Residential 9,600 sq. ft.	SFR-Basic
04 115258 RK	PRD-9,600	Residential 9,600 sq. ft.	SFR-Basic
04 115717 RK	PRD-9,600	Residential 9,600 sq. ft.	SFR-Basic
04 116601 RK	PRD-9,600	Residential 9,600 sq. ft.	SFR-Basic
04 116947 RK	PRD-9,600	Residential 9,600 sq. ft.	SFR-Basic
04 115714 RK	PRD-9,600	Residential 9,600 sq. ft.	SFR-Basic
04 117670 RK	PRD-9,600	Residential 9,600 sq. ft.	SFR-Basic
04 120012 RK	PRD-9,600	Residential 9,600 sq. ft.	SFR-Basic
04 114566 RK	PRD-9,600	Residential 9,600 sq. ft.	SFR-Basic
04 114572 RK	PRD-9,600	Residential 9,600 sq. ft.	SFR-Basic
04 114567 RK	PRD-9,600	Residential 9,600 sq. ft.	SFR-Basic
04 115256 RK	PRD-9,600	Residential 9,600 sq. ft.	SFR-Basic
04 114864 RK	PRD-9,600	Residential 9,600 sq. ft.	SFR-Basic
04 114569 RK	PRD-9,600	Residential 9,600 sq. ft.	SFR-Basic
04 116691 RK	PRD-9,600	Residential 9,600 sq. ft.	SFR-Basic
04 114867 RK	PRD-9,600	Residential 9,600 sq. ft.	SFR-Basic
04 115952 RK	PRD-9,600	Residential 9,600 sq. ft.	SFR-Basic
04 115259 RK	PRD-9,600	Residential 9,600 sq. ft.	SFR-Basic
04 115725 RK	PRD-9,600	Residential 9,600 sq. ft.	SFR-Basic
04 114563 RK	PRD-9,600	Residential 9,600 sq. ft.	SFR-Basic
04 112762 RK	R-5	Rural-5 Acre	Single Family Res-Combo
04 112209 RK	RC	Rural Conservation	Single Family Res-Combo
04 112249 RK			Duplex-Basic
04 112263 RK	R-5	Rural-5 Acre	Single Family Res-Combo
04 112322 RK	PRD-20,000(M	Residential 20,000 sq. ft.	Single Family Res-Combo
04 109345 RK	R-5	Rural-5 Acre	Single Family Res-Combo
04 112780 RK	R-5	Rural-5 Acre	SFR-Basic
04 109339 RK	R-5	Rural-5 Acre	Single Family Res-Combo
04 112885 RK	R-5	Rural-5 Acre	SFR-Basic
04 112888 RK	R-5	Rural-5 Acre	SFR-Basic
04 114323 RK	R-5	Rural-5 Acre	SFR-Basic
04 113136 RK	R-5	Rural-5 Acre	SFR-Basic
04 114325 RK	R-5	Rural-5 Acre	SFR-Basic
04 115145 RK	R-5	Rural-5 Acre	SFR-Basic
04 115142 RK	R-5	Rural-5 Acre	SFR-Basic
04 115146 RK	R-5	Rural-5 Acre	SFR-Basic
04 115155 RK	R-5	Rural-5 Acre	SFR-Basic
04 116708 RK	R-5	Rural-5 Acre	SFR-Basic
04 113139 RK	R-5	Rural-5 Acre	SFR-Basic
04 113133 RK	R-5	Rural-5 Acre	SFR-Basic
04 113135 RK	R-5	Rural-5 Acre	SFR-Basic
04 113142 RK	R-5	Rural-5 Acre	SFR-Basic
04 114327 RK	R-5	Rural-5 Acre	SFR-Basic
04 112892 RK	R-5	Rural-5 Acre	SFR-Basic
04 114328 RK	R-5	Rural-5 Acre	SFR-Basic
04 112886 RK	R-5	Rural-5 Acre	SFR-Basic

Accessory Dwelling Units

Index # - File Name: 1.0022 - Single Family Dwellings Data\_Snohomish County.pdf

04 120570 RK	R-5	Rural-5 Acre	SFR-Basic
04 115271 RK	R-5	Rural-5 Acre	Single Family Res-Combo
04 114722 RK	RD	Rural Diversification	Single Family Res-Combo
04 113440 RK	R-5	Rural-5 Acre	Single Family Res-Combo
04 113443 RK	R-5	Rural-5 Acre	Accessory Apt Detached-Combo
04 120684 RK	PRD-9,600	Residential 9,600 sq. ft.	SFR-Basic
04 116692 RK	PRD-9,600	Residential 9,600 sq. ft.	SFR-Basic
04 115726 RK	PRD-9,600	Residential 9,600 sq. ft.	SFR-Basic
04 116600 RK	PRD-9,600	Residential 9,600 sq. ft.	SFR-Basic
04 112053 RK	R-5	Rural-5 Acre	Single Family Res-Combo
04 112057 RK	R-5	Rural-5 Acre	Single Family Res-Combo
04 112161 RK	R-5	Rural-5 Acre	Single Family Res-Combo
04 121267 RK	R-7,200(PRD)	Residential 7,200 sq. ft.	SFR-Basic
04 120579 RK	R-7,200(PRD)	Residential 7,200 sq. ft.	SFR-Basic
04 120006 RK	PRD-9,600	Residential 9,600 sq. ft.	SFR-Basic
04 121372 RK	PRD-9,600	Residential 9,600 sq. ft.	SFR-Basic
04 115263 RK	PRD-9,600	Residential 9,600 sq. ft.	SFR-Basic
04 113737 RK	R-5	Rural-5 Acre	Single Family Res-Combo
04 112611 RK	LDMR	Low Density Multiple Reside	Single Family Res-Combo
04 112613 RK	LDMR	Low Density Multiple Reside	Single Family Res-Combo
04 113499 RK	LDMR	Low Density Multiple Reside	SFR-Basic
04 113501 RK	LDMR	Low Density Multiple Reside	SFR-Basic
04 113497 RK	LDMR	Low Density Multiple Reside	SFR-Basic
04 113503 RK	LDMR	Low Density Multiple Reside	SFR-Basic
04 112652 RK	R-5	Rural-5 Acre	SFR-Basic
04 116453 RK	R-5	Rural-5 Acre	SFR-Basic
04 117127 RK	R-5	Rural-5 Acre	SFR-Basic
04 118011 RK	R-5	Rural-5 Acre	SFR-Basic
04 112747 RK	R-5	Rural-5 Acre	Single Family Res-Combo
04 112655 RK	R-5	Rural-5 Acre	SFR-Basic
04 112682 RK	R-5	Rural-5 Acre	SFR-Basic
04 109788 RK	R-5	Rural-5 Acre	SFR-Basic
04 112683 RK	R-5	Rural-5 Acre	SFR-Basic
04 120163 RK	R-5	Rural-5 Acre	SFR-Basic
04 112746 RK	R-5	Rural-5 Acre	SFR-Basic
04 118923 RK	R-5	Rural-5 Acre	SFR-Basic
04 118910 RK	R-5	Rural-5 Acre	SFR-Basic
04 115036 RK	R-5	Rural-5 Acre	SFR-Basic
04 112785 RK	R-5	Rural-5 Acre	SFR-Basic
04 118912 RK	R-5	Rural-5 Acre	SFR-Basic
04 118006 RK	R-5	Rural-5 Acre	SFR-Basic
04 118008 RK	R-5	Rural-5 Acre	SFR-Basic
04 118002 RK	R-5	Rural-5 Acre	SFR-Basic
04 112615 RK	R-5	Rural-5 Acre	Single Family Res-Combo
04 113461 RK	PRD-7,200	Residential 7,200 sq. ft.	SFR-Basic
04 113458 RK	PRD-7,200	Residential 7,200 sq. ft.	SFR-Basic
04 115422 RK	PRD-7,200	Residential 7,200 sq. ft.	SFR-Basic

Accessory Dwelling Units

Index # - File Name: 1.0022 - Single Family Dwellings Data\_Snohomish County.pdf

04 114855 RK	PRD-7,200	Residential 7,200 sq. ft.	SFR-Basic
04 114856 RK	PRD-7,200	Residential 7,200 sq. ft.	SFR-Basic
04 114857 RK	PRD-7,200	Residential 7,200 sq. ft.	SFR-Basic
04 115421 RK	PRD-7,200	Residential 7,200 sq. ft.	SFR-Basic
04 115419 RK	PRD-7,200	Residential 7,200 sq. ft.	SFR-Basic
04 115417 RK	PRD-7,200	Residential 7,200 sq. ft.	SFR-Basic
04 113796 RK	PRD-7,200	Residential 7,200 sq. ft.	SFR-Basic
04 121560 RK	PRD-7,200	Residential 7,200 sq. ft.	SFR-Basic
04 113919 RK	PRD-7,200	Residential 7,200 sq. ft.	SFR-Basic
04 113926 RK	PRD-7,200	Residential 7,200 sq. ft.	SFR-Basic
04 113927 RK	PRD-7,200	Residential 7,200 sq. ft.	SFR-Basic
04 113928 RK	PRD-7,200	Residential 7,200 sq. ft.	SFR-Basic
04 113929 RK	PRD-7,200	Residential 7,200 sq. ft.	SFR-Basic
04 113930 RK	PRD-7,200	Residential 7,200 sq. ft.	SFR-Basic
04 113931 RK	PRD-7,200	Residential 7,200 sq. ft.	SFR-Basic
04 113937 RK	PRD-7,200	Residential 7,200 sq. ft.	SFR-Basic
04 113936 RK	PRD-7,200	Residential 7,200 sq. ft.	SFR-Basic
04 113935 RK	PRD-7,200	Residential 7,200 sq. ft.	SFR-Basic
04 113934 RK	PRD-7,200	Residential 7,200 sq. ft.	SFR-Basic
04 113933 RK	PRD-7,200	Residential 7,200 sq. ft.	SFR-Basic
04 113925 RK	PRD-7,200	Residential 7,200 sq. ft.	SFR-Basic
04 113947 RK	PRD-7,200	Residential 7,200 sq. ft.	SFR-Basic
04 121553 RK	PRD-7,200	Residential 7,200 sq. ft.	SFR-Basic
04 113559 RK	PRD-7,200	Residential 7,200 sq. ft.	SFR-Basic
04 114007 RK	PRD-7,200	Residential 7,200 sq. ft.	SFR-Basic
04 114005 RK	PRD-7,200	Residential 7,200 sq. ft.	SFR-Basic
04 117045 RK	PRD-7,200	Residential 7,200 sq. ft.	SFR-Basic
04 117046 RK	PRD-7,200	Residential 7,200 sq. ft.	SFR-Basic
04 114006 RK	PRD-7,200	Residential 7,200 sq. ft.	SFR-Basic
04 114011 RK	PRD-7,200	Residential 7,200 sq. ft.	SFR-Basic
04 113912 RK	PRD-7,200	Residential 7,200 sq. ft.	SFR-Basic
04 113915 RK	PRD-7,200	Residential 7,200 sq. ft.	SFR-Basic
04 113918 RK	PRD-7,200	Residential 7,200 sq. ft.	SFR-Basic
04 113917 RK	PRD-7,200	Residential 7,200 sq. ft.	SFR-Basic
04 113914 RK	PRD-7,200	Residential 7,200 sq. ft.	SFR-Basic
04 113916 RK	PRD-7,200	Residential 7,200 sq. ft.	SFR-Basic
04 115930 RK	PRD-7,200	Residential 7,200 sq. ft.	SFR-Basic
04 115929 RK	PRD-7,200	Residential 7,200 sq. ft.	SFR-Basic
04 115928 RK	PRD-7,200	Residential 7,200 sq. ft.	SFR-Basic
04 115926 RK	PRD-7,200	Residential 7,200 sq. ft.	SFR-Basic
04 115927 RK	PRD-7,200	Residential 7,200 sq. ft.	SFR-Basic
04 116196 RK	PRD-7,200	Residential 7,200 sq. ft.	SFR-Basic
04 113792 RK	PRD-7,200	Residential 7,200 sq. ft.	SFR-Basic
04 113798 RK	PRD-7,200	Residential 7,200 sq. ft.	SFR-Basic
04 116950 RK	PRD-7,200	Residential 7,200 sq. ft.	SFR-Basic
04 117047 RK	PRD-7,200	Residential 7,200 sq. ft.	SFR-Basic
04 113921 RK	PRD-7,200	Residential 7,200 sq. ft.	SFR-Basic



Accessory Dwelling Units

Index # - File Name: 1.0022 - Single Family Dwellings Data\_Snohomish County.pdf

04 113469 RK	PRD-7,200	Residential 7,200 sq. ft.	SFR-Basic
04 113464 RK	PRD-7,200	Residential 7,200 sq. ft.	SFR-Basic
04 115991 RK	PRD-7,200	Residential 7,200 sq. ft.	SFR-Basic
04 115993 RK	PRD-7,200	Residential 7,200 sq. ft.	SFR-Basic
04 113567 RK	PRD-7,200	Residential 7,200 sq. ft.	SFR-Basic
04 120344 RK	PRD-7,200	Residential 7,200 sq. ft.	SFR-Basic
04 113569 RK	PRD-7,200	Residential 7,200 sq. ft.	SFR-Basic
04 113572 RK	PRD-7,200	Residential 7,200 sq. ft.	SFR-Basic
04 120345 RK	PRD-7,200	Residential 7,200 sq. ft.	SFR-Basic
04 113574 RK	PRD-7,200	Residential 7,200 sq. ft.	SFR-Basic
04 113560 RK	PRD-7,200	Residential 7,200 sq. ft.	SFR-Basic
04 110414 RK	R-5	Rural-5 Acre	Single Family Res-Combo
04 114717 RK	R-5	Rural-5 Acre	SFR-Basic
04 113408 RK	R-5	Rural-5 Acre	SFR-Basic
04 114726 RK	R-5	Rural-5 Acre	SFR-Basic
04 114724 RK	R-5	Rural-5 Acre	SFR-Basic
04 114729 RK	R-5	Rural-5 Acre	SFR-Basic
04 114731 RK	R-5	Rural-5 Acre	SFR-Basic
04 114735 RK	R-5	Rural-5 Acre	SFR-Basic
04 115244 RK	R-5	Rural-5 Acre	Single Family Res-Combo
04 113406 RK	R-5	Rural-5 Acre	SFR-Basic
04 113470 RK	R-5	Rural-5 Acre	SFR-Basic
04 113474 RK	R-5	Rural-5 Acre	SFR-Basic
04 112980 RK	R-5	Rural-5 Acre	SFR-Basic
04 112979 RK	R-5	Rural-5 Acre	SFR-Basic
04 112981 RK	R-5	Rural-5 Acre	SFR-Basic
03 110887 RK	R-5	Rural-5 Acre	Single Family Res-Combo
04 113271 RK	R-5	Rural-5 Acre	Single Family Res-Combo
04 116657 RK	F	Forestry	Single Family Res-Combo
04 112786 RK	R-5	Rural-5 Acre	Single Family Res-Combo
04 110412 RK	R-5	Rural-5 Acre	Single Family Res-Combo
04 113070 RK	R-5	Rural-5 Acre	SFR-Basic
04 110411 RK	R-5	Rural-5 Acre	Single Family Res-Combo
04 110418 RK	R-5	Rural-5 Acre	Single Family Res-Combo
04 113073 RK	R-5	Rural-5 Acre	SFR-Basic
04 110419 RK	R-5	Rural-5 Acre	Single Family Res-Combo
04 114739 RK	R-5	Rural-5 Acre	SFR-Basic
04 114740 RK	R-5	Rural-5 Acre	SFR-Basic
04 114760 RK	R-5	Rural-5 Acre	SFR-Basic
03 110401 RK	R-9,600	Residential 9,600 sq. ft.	Single Family Res-Combo
04 109431 RK	R-9,600	Residential 9,600 sq. ft.	Single Family Res-Combo
04 117860 RK	R-5	Rural-5 Acre	Single Family Res-Combo
03 111016 RK	R-5	Rural-5 Acre	Single Family Res-Combo
04 110596 RK	R-5	Rural-5 Acre	SFR-Basic
04 117571 RK	R-5	Rural-5 Acre	Single Family Res-Combo
03 111019 RK	R-5	Rural-5 Acre	Single Family Res-Combo
03 109393 RK	R-7,200	Residential 7,200 sq. ft.	Single Family Res-Combo

Accessory Dwelling Units

Index # - File Name: 1.0022 - Single Family Dwellings Data\_Snohomish County.pdf

03 111122 RK	R-9,600	Residential 9,600 sq. ft.	Single Family Res-Combo
03 109993 RK	R-9,600	Residential 9,600 sq. ft.	Single Family Res-Combo
04 100319 RK	R-9,600	Residential 9,600 sq. ft.	Single Family Res-Combo
04 100321 RK	R-9,600	Residential 9,600 sq. ft.	Single Family Res-Combo
03 102609 RK	R-9,600	Residential 9,600 sq. ft.	Single Family Res-Combo
04 110628 RK	R-9,600	Residential 9,600 sq. ft.	Single Family Res-Combo
04 110625 RK	R-9,600	Residential 9,600 sq. ft.	Single Family Res-Combo
04 111005 RK	R-9,600	Residential 9,600 sq. ft.	Single Family Res-Combo
04 111795 RK	R-9,600	Residential 9,600 sq. ft.	Single Family Res-Combo
03 101905 RK	R-9,600	Residential 9,600 sq. ft.	Single Family Res-Combo
04 111004 RK	R-9,600	Residential 9,600 sq. ft.	Single Family Res-Combo
04 110367 RK	R-9,600	Residential 9,600 sq. ft.	Single Family Res-Combo
04 110369 RK	R-9,600	Residential 9,600 sq. ft.	Single Family Res-Combo
04 110370 RK	R-9,600	Residential 9,600 sq. ft.	Single Family Res-Combo
04 110106 RK	R-9,600	Residential 9,600 sq. ft.	Single Family Res-Combo
04 110371 RK	R-9,600	Residential 9,600 sq. ft.	Single Family Res-Combo
04 110372 RK	R-9,600	Residential 9,600 sq. ft.	Single Family Res-Combo
04 100323 RK	R-9,600	Residential 9,600 sq. ft.	Single Family Res-Combo
04 100324 RK	R-9,600	Residential 9,600 sq. ft.	Single Family Res-Combo
04 109836 RK	R-9,600	Residential 9,600 sq. ft.	Single Family Res-Combo
04 109430 RK	R-9,600	Residential 9,600 sq. ft.	Single Family Res-Combo
04 109434 RK	R-9,600	Residential 9,600 sq. ft.	Single Family Res-Combo
04 109436 RK	R-9,600	Residential 9,600 sq. ft.	Single Family Res-Combo
04 109435 RK	R-9,600	Residential 9,600 sq. ft.	Single Family Res-Combo
04 109838 RK	R-9,600	Residential 9,600 sq. ft.	Single Family Res-Combo
04 109840 RK	R-9,600	Residential 9,600 sq. ft.	Single Family Res-Combo
04 100325 RK	R-9,600	Residential 9,600 sq. ft.	Single Family Res-Combo
04 100326 RK	R-9,600	Residential 9,600 sq. ft.	Single Family Res-Combo
03 109992 RK	R-9,600	Residential 9,600 sq. ft.	Single Family Res-Combo
04 110359 RK	R-7,200	Residential 7,200 sq. ft.	Single Family Res-Combo
04 111711 RK	R-7,200	Residential 7,200 sq. ft.	SFR-Basic
04 110698 RK	R-7,200	Residential 7,200 sq. ft.	Single Family Res-Combo
04 110092 RK	R-7,200	Residential 7,200 sq. ft.	Single Family Res-Combo
04 109424 RK	R-7,200	Residential 7,200 sq. ft.	SFR-Basic
03 109163 RK	R-7,200	Residential 7,200 sq. ft.	Single Family Res-Combo
03 108782 RK	R-7,200	Residential 7,200 sq. ft.	Single Family Res-Combo
04 118068 RK	R-7,200	Residential 7,200 sq. ft.	Single Family Res-Combo
03 109004 RK	R-7,200	Residential 7,200 sq. ft.	Duplex-Combo
03 107241 RK	CITY	City	Single Family Res-Combo
04 110704 RK	R-5	Rural-5 Acre	Single Family Res-Combo
04 110476 RK	R-5	Rural-5 Acre	Single Family Res-Combo
04 113409 RK	R-7,200	Residential 7,200 sq. ft.	Single Family Res-Combo
03 108404 RK	R-7,200	Residential 7,200 sq. ft.	Single Family Res-Combo
04 114772 RK	R-5	Rural-5 Acre	Single Family Res-Combo
04 120629 RK	R-5	Rural-5 Acre	Single Family Res-Combo
04 114477 RK	R-5	Rural-5 Acre	Single Family Res-Combo
04 109834 RK	CITY	City	Single Family Res-Combo

Accessory Dwelling Units

Index # - File Name: 1.0022 - Single Family Dwellings Data\_Snohomish County.pdf

03 109214 RK	CITY	City	Single Family Res-Combo
04 100234 RK	CITY	City	Single Family Res-Combo
04 100235 RK	CITY	City	Single Family Res-Combo
03 109212 RK	CITY	City	Single Family Res-Combo
03 109211 RK	CITY	City	Single Family Res-Combo
03 111124 RK	CITY	City	Single Family Res-Combo
03 109822 RK	CITY	City	Single Family Res-Combo
03 107681 RK	CITY	City	Single Family Res-Combo
03 107671 RK	CITY	City	Single Family Res-Combo
03 107677 RK	CITY	City	Single Family Res-Combo
04 115352 MH	F	Forestry	Double Wide
03 108191 RK	CITY	City	Single Family Res-Combo
03 107674 RK	CITY	City	Single Family Res-Combo
04 108937 RK	R-5	Rural-5 Acre	SFR-Basic
04 109202 RK	R-5	Rural-5 Acre	Single Family Res-Combo
04 109095 RK	R-5	Rural-5 Acre	Single Family Res-Combo
03 110860 RK	R-5	Rural-5 Acre	Single Family Res-Combo
03 108097 RK	R-5	Rural-5 Acre	Single Family Res-Combo
04 119013 RK	R-7,200	Residential 7,200 sq. ft.	SFR-Basic
04 118614 RK	R-7,200	Residential 7,200 sq. ft.	SFR-Basic
04 117013 RK	R-7,200	Residential 7,200 sq. ft.	SFR-Basic
04 117443 RK	R-7,200	Residential 7,200 sq. ft.	SFR-Basic
04 117650 RK	R-7,200	Residential 7,200 sq. ft.	SFR-Basic
04 117248 RK	R-7,200	Residential 7,200 sq. ft.	SFR-Basic
04 117252 RK	R-7,200	Residential 7,200 sq. ft.	SFR-Basic
04 116516 RK	R-7,200	Residential 7,200 sq. ft.	SFR-Basic
04 116495 RK	R-7,200	Residential 7,200 sq. ft.	SFR-Basic
04 116514 RK	R-7,200	Residential 7,200 sq. ft.	SFR-Basic
04 117264 RK	R-7,200	Residential 7,200 sq. ft.	SFR-Basic
04 119553 RK	R-7,200	Residential 7,200 sq. ft.	SFR-Basic
04 118422 RK	R-7,200	Residential 7,200 sq. ft.	SFR-Basic
04 117647 RK	R-7,200	Residential 7,200 sq. ft.	SFR-Basic
04 118616 RK	R-7,200	Residential 7,200 sq. ft.	SFR-Basic
04 120596 RK	R-7,200	Residential 7,200 sq. ft.	SFR-Basic
04 121058 RK	R-7,200	Residential 7,200 sq. ft.	SFR-Basic
04 119797 RK	R-7,200	Residential 7,200 sq. ft.	SFR-Basic
04 119222 RK	R-7,200	Residential 7,200 sq. ft.	SFR-Basic
04 117447 RK	R-7,200	Residential 7,200 sq. ft.	SFR-Basic
04 117245 RK	R-7,200	Residential 7,200 sq. ft.	SFR-Basic
04 120115 RK	R-7,200	Residential 7,200 sq. ft.	SFR-Basic
04 120465 RK	R-7,200	Residential 7,200 sq. ft.	SFR-Basic
04 119798 RK	R-7,200	Residential 7,200 sq. ft.	SFR-Basic
04 120110 RK	R-7,200	Residential 7,200 sq. ft.	SFR-Basic
04 120467 RK	R-7,200	Residential 7,200 sq. ft.	SFR-Basic
04 120830 RK	R-7,200	Residential 7,200 sq. ft.	SFR-Basic
04 113726 RK	R-7,200	Residential 7,200 sq. ft.	SFR-Basic
04 113732 RK	R-7,200	Residential 7,200 sq. ft.	SFR-Basic

Accessory Dwelling Units

Index # - File Name: 1.0022 - Single Family Dwellings Data\_Snohomish County.pdf

03 108202 RK	R-7,200	Residential 7,200 sq. ft.	Single Family Res-Combo
04 113023 RK	R-7,200	Residential 7,200 sq. ft.	SFR-Basic
03 108015 RK	R-7,200	Residential 7,200 sq. ft.	Single Family Res-Combo
04 113960 RK	R-7,200	Residential 7,200 sq. ft.	SFR-Basic
04 113735 RK	R-7,200	Residential 7,200 sq. ft.	SFR-Basic
03 103148 RK	R-7,200	Residential 7,200 sq. ft.	Single Family Res-Combo
03 107783 RK	R-7,200	Residential 7,200 sq. ft.	Single Family Res-Combo
04 113030 RK	R-7,200	Residential 7,200 sq. ft.	SFR-Basic
04 113031 RK	R-7,200	Residential 7,200 sq. ft.	SFR-Basic
03 103946 RK	R-7,200	Residential 7,200 sq. ft.	Single Family Res-Combo
04 112359 RK	R-7,200	Residential 7,200 sq. ft.	SFR-Basic
04 112360 RK	R-7,200	Residential 7,200 sq. ft.	SFR-Basic
04 111926 RK	R-7,200	Residential 7,200 sq. ft.	SFR-Basic
04 112162 RK	R-7,200	Residential 7,200 sq. ft.	SFR-Basic
04 112163 RK	R-7,200	Residential 7,200 sq. ft.	SFR-Basic
03 103147 RK	R-7,200	Residential 7,200 sq. ft.	Single Family Res-Combo
03 103126 RK	R-7,200	Residential 7,200 sq. ft.	Single Family Res-Combo
04 109851 RK	R-7,200	Residential 7,200 sq. ft.	SFR-Basic
04 110140 RK	R-7,200	Residential 7,200 sq. ft.	SFR-Basic
03 103619 RK	R-7,200	Residential 7,200 sq. ft.	Single Family Res-Combo
04 110432 RK	R-7,200	Residential 7,200 sq. ft.	SFR-Basic
03 108020 RK	R-7,200	Residential 7,200 sq. ft.	Single Family Res-Combo
04 110136 RK	R-7,200	Residential 7,200 sq. ft.	SFR-Basic
03 103948 RK	R-7,200	Residential 7,200 sq. ft.	Single Family Res-Combo
03 103604 RK	R-7,200	Residential 7,200 sq. ft.	Single Family Res-Combo
03 104377 RK	R-7,200	Residential 7,200 sq. ft.	Single Family Res-Combo
04 108697 RK	R-7,200	Residential 7,200 sq. ft.	SFR-Basic
03 103953 RK	R-7,200	Residential 7,200 sq. ft.	Single Family Res-Combo
03 107802 RK	R-7,200	Residential 7,200 sq. ft.	Single Family Res-Combo
04 109390 RK	R-7,200	Residential 7,200 sq. ft.	SFR-Basic
03 103945 RK	R-7,200	Residential 7,200 sq. ft.	Single Family Res-Combo
04 110688 RK	R-7,200	Residential 7,200 sq. ft.	SFR-Basic
03 104394 RK	R-7,200	Residential 7,200 sq. ft.	Single Family Res-Combo
03 107995 RK	R-7,200	Residential 7,200 sq. ft.	Single Family Res-Combo
03 107982 RK	R-7,200	Residential 7,200 sq. ft.	Single Family Res-Combo
03 107985 RK	R-7,200	Residential 7,200 sq. ft.	Single Family Res-Combo
03 108022 RK	R-7,200	Residential 7,200 sq. ft.	Single Family Res-Combo
03 108011 RK	R-7,200	Residential 7,200 sq. ft.	Single Family Res-Combo
03 103955 RK	R-7,200	Residential 7,200 sq. ft.	Single Family Res-Combo
04 109612 RK	R-7,200	Residential 7,200 sq. ft.	SFR-Basic
03 103952 RK	R-7,200	Residential 7,200 sq. ft.	Single Family Res-Combo
03 104374 RK	R-7,200	Residential 7,200 sq. ft.	Single Family Res-Combo
04 109853 RK	R-7,200	Residential 7,200 sq. ft.	SFR-Basic
03 103146 RK	R-7,200	Residential 7,200 sq. ft.	Single Family Res-Combo
03 103118 RK	R-7,200	Residential 7,200 sq. ft.	Single Family Res-Combo
04 111059 RK	R-7,200	Residential 7,200 sq. ft.	SFR-Basic
04 118419 RK	R-7,200	Residential 7,200 sq. ft.	SFR-Basic

Accessory Dwelling Units

Index # - File Name: 1.0022 - Single Family Dwellings Data\_Snohomish County.pdf

03 103149 RK	R-7,200	Residential 7,200 sq. ft.	Single Family Res-Combo
03 104371 RK	R-7,200	Residential 7,200 sq. ft.	Single Family Res-Combo
03 104382 RK	R-7,200	Residential 7,200 sq. ft.	Single Family Res-Combo
04 111061 RK	R-7,200	Residential 7,200 sq. ft.	SFR-Basic
03 104248 RK	R-7,200	Residential 7,200 sq. ft.	Single Family Res-Combo
04 112761 RK	R-7,200	Residential 7,200 sq. ft.	SFR-Basic
03 107801 RK	R-7,200	Residential 7,200 sq. ft.	Single Family Res-Combo
04 110686 RK	R-7,200	Residential 7,200 sq. ft.	SFR-Basic
03 107803 RK	R-7,200	Residential 7,200 sq. ft.	Single Family Res-Combo
04 111302 RK	R-7,200	Residential 7,200 sq. ft.	SFR-Basic
04 111062 RK	R-7,200	Residential 7,200 sq. ft.	SFR-Basic
04 120113 RK	R-7,200	Residential 7,200 sq. ft.	SFR-Basic
03 104383 RK	R-7,200	Residential 7,200 sq. ft.	Single Family Res-Combo
03 103134 RK	R-7,200	Residential 7,200 sq. ft.	Single Family Res-Combo
04 111538 RK	R-7,200	Residential 7,200 sq. ft.	SFR-Basic
04 112365 RK	R-7,200	Residential 7,200 sq. ft.	SFR-Basic
04 100394 RK	R-5	Rural-5 Acre	SFR-Basic
04 120244 RK	R-5	Rural-5 Acre	SFR-Basic
04 100258 RK	R-5	Rural-5 Acre	SFR-Basic
04 108609 RK	R-5	Rural-5 Acre	SFR-Basic
04 117599 RK	R-5	Rural-5 Acre	SFR-Basic
04 100256 RK	R-5	Rural-5 Acre	SFR-Basic
03 111074 RK	R-5	Rural-5 Acre	SFR-Basic
04 120240 RK	R-5	Rural-5 Acre	SFR-Basic
04 100143 RK	R-7,200	Residential 7,200 sq. ft.	SFR-Basic
03 111075 RK	R-7,200	Residential 7,200 sq. ft.	SFR-Basic
04 100299 RK	R-7,200	Residential 7,200 sq. ft.	SFR-Basic
04 113504 RK	R-7,200	Residential 7,200 sq. ft.	SFR-Basic
03 111076 RK	R-7,200	Residential 7,200 sq. ft.	SFR-Basic
04 109685 RK	R-7,200	Residential 7,200 sq. ft.	SFR-Basic
04 108627 RK	R-7,200	Residential 7,200 sq. ft.	SFR-Basic
04 108628 RK	R-7,200	Residential 7,200 sq. ft.	SFR-Basic
04 109684 RK	R-7,200	Residential 7,200 sq. ft.	SFR-Basic
04 110165 RK	R-7,200	Residential 7,200 sq. ft.	SFR-Basic
04 110167 RK	R-7,200	Residential 7,200 sq. ft.	SFR-Basic
04 110831 RK	R-7,200	Residential 7,200 sq. ft.	SFR-Basic
04 110168 RK	R-7,200	Residential 7,200 sq. ft.	SFR-Basic
04 110169 RK	R-7,200	Residential 7,200 sq. ft.	SFR-Basic
04 109896 RK	R-7,200	Residential 7,200 sq. ft.	SFR-Basic
04 111104 RK	R-7,200	Residential 7,200 sq. ft.	SFR-Basic
04 111105 RK	R-7,200	Residential 7,200 sq. ft.	SFR-Basic
04 100296 RK	R-7,200	Residential 7,200 sq. ft.	SFR-Basic
04 109319 RK	R-7,200	Residential 7,200 sq. ft.	SFR-Basic
04 118559 RK	R-5	Rural-5 Acre	Single Family Res-Combo
04 110571 RK	R-5	Rural-5 Acre	Single Family Res-Combo
04 108728 RK	R-5	Rural-5 Acre	Single Family Res-Combo
04 108725 RK	R-5	Rural-5 Acre	Single Family Res-Combo

Accessory Dwelling Units

Index # - File Name: 1.0022 - Single Family Dwellings Data\_Snohomish County.pdf

04 109406 RK	R-5	Rural-5 Acre	SFR-Basic
04 100312 RK	R-5	Rural-5 Acre	Single Family Res-Combo
04 109403 RK	R-5	Rural-5 Acre	SFR-Basic
04 100313 RK	R-5	Rural-5 Acre	Single Family Res-Combo
04 100314 RK	R-5	Rural-5 Acre	Single Family Res-Combo
04 109350 RK	R-5	Rural-5 Acre	Single Family Res-Combo
04 109352 RK	R-5	Rural-5 Acre	Single Family Res-Combo
04 110582 RK	R-5	Rural-5 Acre	Single Family Res-Combo
04 108722 RK	R-5	Rural-5 Acre	Single Family Res-Combo
04 119628 RK	R-5	Rural-5 Acre	Single Family Res-Combo
04 112323 RK	R-5	Rural-5 Acre	Single Family Res-Combo
03 110978 RK	R-5	Rural-5 Acre	Single Family Res-Combo
02 108912 RK	R-5	Rural-5 Acre	Single Family Res-Combo
04 111289 RK	F	Forestry	Single Family Res-Combo
03 111024 RK	R-5	Rural-5 Acre	Single Family Res-Combo
03 110937 RK	PRD-7,200	Residential 7,200 sq. ft.	Single Family Res-Combo
03 108380 RK	PRD-7,200	Residential 7,200 sq. ft.	SFR-Basic
04 108637 RK	PRD-7,200	Residential 7,200 sq. ft.	Single Family Res-Combo
04 116078 RK	R-5	Rural-5 Acre	Single Family Res-Combo
04 110078 RK	R-5	Rural-5 Acre	Single Family Res-Combo
04 112082 RK	R-5	Rural-5 Acre	Single Family Res-Combo
04 110505 RK	R-5	Rural-5 Acre	Single Family Res-Combo
04 111973 RK	R-5	Rural-5 Acre	Single Family Res-Combo
04 111103 RK	R-5	Rural-5 Acre	Single Family Res-Combo
03 109471 RK	R-5	Rural-5 Acre	SFR-Basic
04 110857 RK	R-5	Rural-5 Acre	Single Family Res-Combo
04 111545 RK	R-5	Rural-5 Acre	Single Family Res-Combo
04 111353 RK	R-5	Rural-5 Acre	Single Family Res-Combo
04 109791 RK	R-5	Rural-5 Acre	Single Family Res-Combo
04 109792 RK	R-5	Rural-5 Acre	Single Family Res-Combo
04 109789 RK	R-5	Rural-5 Acre	Single Family Res-Combo
04 109790 RK	R-5	Rural-5 Acre	Single Family Res-Combo
04 110219 RK	R-9,600	Residential 9,600 sq. ft.	SFR-Basic
04 114560 RK	R-9,600	Residential 9,600 sq. ft.	SFR-Basic
04 114562 RK	R-9,600	Residential 9,600 sq. ft.	SFR-Basic
04 110211 RK	R-9,600	Residential 9,600 sq. ft.	SFR-Basic
04 110213 RK	R-9,600	Residential 9,600 sq. ft.	SFR-Basic
04 114561 RK	R-9,600	Residential 9,600 sq. ft.	SFR-Basic
04 109739 RK	LDMR	Low Density Multiple Reside	Single Family Res-Combo
04 109841 RK	LDMR	Low Density Multiple Reside	Single Family Res-Combo
04 109843 RK	LDMR	Low Density Multiple Reside	Single Family Res-Combo
03 110971 RK	CITY	City	Single Family Res-Combo
04 110395 RK	R-9,600	Residential 9,600 sq. ft.	Single Family Res-Combo
04 110209 RK	R-9,600	Residential 9,600 sq. ft.	SFR-Basic
04 113178 RK	R-9,600	Residential 9,600 sq. ft.	SFR-Basic
03 110557 RK	R-9,600	Residential 9,600 sq. ft.	Single Family Res-Combo
03 110558 RK	R-9,600	Residential 9,600 sq. ft.	Single Family Res-Combo

Accessory Dwelling Units

Index # - File Name: 1.0022 - Single Family Dwellings Data\_Snohomish County.pdf

03 110560 RK	R-9,600	Residential 9,600 sq. ft.	Single Family Res-Combo
04 116364 RK	R-5	Rural-5 Acre	Single Family Res-Combo
04 113419 RK	R-5	Rural-5 Acre	Single Family Res-Combo
04 114761 RK	R-5	Rural-5 Acre	Single Family Res-Combo
04 111270 RK	R-5	Rural-5 Acre	Single Family Res-Combo
04 119193 RK	R-5	Rural-5 Acre	Single Family Res-Combo
04 109994 RK	R-5	Rural-5 Acre	Single Family Res-Combo
04 111261 RK	R-9,600	Residential 9,600 sq. ft.	SFR-Basic
04 110216 RK	R-9,600	Residential 9,600 sq. ft.	SFR-Basic
03 110555 RK	R-9,600	Residential 9,600 sq. ft.	Single Family Res-Combo
04 113176 RK	R-9,600	Residential 9,600 sq. ft.	SFR-Basic
03 110546 RK	R-9,600	Residential 9,600 sq. ft.	Single Family Res-Combo
04 110220 RK	R-9,600	Residential 9,600 sq. ft.	SFR-Basic
04 110210 RK	R-9,600	Residential 9,600 sq. ft.	SFR-Basic
04 110221 RK	R-9,600	Residential 9,600 sq. ft.	SFR-Basic
04 110547 RK	R-9,600	Residential 9,600 sq. ft.	SFR-Basic
04 100379 RK	R-9,600	Residential 9,600 sq. ft.	Single Family Res-Combo
04 109255 RK	R-9,600	Residential 9,600 sq. ft.	SFR-Basic
04 109254 RK	R-9,600	Residential 9,600 sq. ft.	SFR-Basic
04 110548 RK	R-9,600	Residential 9,600 sq. ft.	SFR-Basic
03 110631 RK	R-7,200	Residential 7,200 sq. ft.	Duplex-Combo
04 110094 RK	R-7,200	Residential 7,200 sq. ft.	Duplex-Basic
04 108959 RK	R-7,200	Residential 7,200 sq. ft.	Duplex-Basic
04 108960 RK	R-7,200	Residential 7,200 sq. ft.	Duplex-Basic
04 110095 RK	R-7,200	Residential 7,200 sq. ft.	Duplex-Basic
04 110096 RK	R-7,200	Residential 7,200 sq. ft.	Duplex-Basic
04 110097 RK	R-7,200	Residential 7,200 sq. ft.	Duplex-Basic
04 110099 RK	R-7,200	Residential 7,200 sq. ft.	Duplex-Basic
04 110100 RK	R-7,200	Residential 7,200 sq. ft.	Duplex-Basic
03 111011 RK	R-5	Rural-5 Acre	Single Family Res-Combo
04 111212 RK	R-5	Rural-5 Acre	Single Family Res-Combo
04 112650 RK	R-5	Rural-5 Acre	Single Family Res-Combo
04 118981 RK	R-5	Rural-5 Acre	Single Family Res-Combo
04 118679 RK	R-5	Rural-5 Acre	Single Family Res-Combo
03 109479 RK	R-5	Rural-5 Acre	Single Family Res-Combo
04 111271 RK	R-5	Rural-5 Acre	Single Family Res-Combo
03 110472 MH	R-5	Rural-5 Acre	Triple Wide
04 111021 RK	R-9,600	Residential 9,600 sq. ft.	SFR-Basic
04 111020 RK	R-9,600	Residential 9,600 sq. ft.	SFR-Basic
04 111018 RK	R-9,600	Residential 9,600 sq. ft.	SFR-Basic
04 111259 RK	R-9,600	Residential 9,600 sq. ft.	SFR-Basic
04 111017 RK	R-9,600	Residential 9,600 sq. ft.	SFR-Basic
04 111260 RK	R-9,600	Residential 9,600 sq. ft.	SFR-Basic
04 113174 RK	R-9,600	Residential 9,600 sq. ft.	SFR-Basic
04 112372 RK	R-9,600	Residential 9,600 sq. ft.	SFR-Basic
04 116690 RK	R-9,600	Residential 9,600 sq. ft.	SFR-Basic
04 112374 RK	R-9,600	Residential 9,600 sq. ft.	SFR-Basic

Accessory Dwelling Units

Index # - File Name: 1.0022 - Single Family Dwellings Data\_Snohomish County.pdf

04 112376 RK	R-9,600	Residential 9,600 sq. ft.	SFR-Basic
04 110545 RK	R-9,600	Residential 9,600 sq. ft.	SFR-Basic
04 112378 RK	R-9,600	Residential 9,600 sq. ft.	SFR-Basic
03 110548 RK	R-9,600	Residential 9,600 sq. ft.	Single Family Res-Combo
04 110550 RK	R-9,600	Residential 9,600 sq. ft.	SFR-Basic
04 118776 RK	R-9,600	Residential 9,600 sq. ft.	Single Family Res-Combo
03 111085 RK	R-5	Rural-5 Acre	SFR-Basic
04 111208 RK	R-9,600	Residential 9,600 sq. ft.	Single Family Res-Combo
04 119764 RK	R-9,600	Residential 9,600 sq. ft.	Single Family Res-Combo
04 117166 RK	R-9,600	Residential 9,600 sq. ft.	Single Family Res-Combo
04 109070 RK	R-9,600	Residential 9,600 sq. ft.	SFR-Basic
04 118999 RK	R-9,600	Residential 9,600 sq. ft.	Single Family Res-Combo
04 112233 RK	R-9,600	Residential 9,600 sq. ft.	SFR-Basic
04 115388 RK	R-9,600	Residential 9,600 sq. ft.	Single Family Res-Combo
03 110624 RK	R-9,600	Residential 9,600 sq. ft.	SFR-Basic
04 115385 RK	R-9,600	Residential 9,600 sq. ft.	Single Family Res-Combo
04 115380 RK	R-9,600	Residential 9,600 sq. ft.	Single Family Res-Combo
04 115360 RK	R-9,600	Residential 9,600 sq. ft.	Single Family Res-Combo
04 110928 RK	R-9,600	Residential 9,600 sq. ft.	SFR-Basic
04 110919 RK	R-9,600	Residential 9,600 sq. ft.	SFR-Basic
04 111209 RK	R-9,600	Residential 9,600 sq. ft.	Single Family Res-Combo
04 115398 RK	R-9,600	Residential 9,600 sq. ft.	Single Family Res-Combo
04 112938 RK	R-9,600	Residential 9,600 sq. ft.	Single Family Res-Combo
04 121246 RK	R-9,600	Residential 9,600 sq. ft.	Single Family Res-Combo
04 115390 RK	R-9,600	Residential 9,600 sq. ft.	Single Family Res-Combo
03 111017 RK	R-9,600	Residential 9,600 sq. ft.	Single Family Res-Combo
04 109807 RK	R-9,600	Residential 9,600 sq. ft.	SFR-Basic
04 112937 RK	R-9,600	Residential 9,600 sq. ft.	Single Family Res-Combo
04 115404 RK	R-9,600	Residential 9,600 sq. ft.	Single Family Res-Combo
03 105878 RK	CITY	City	Duplex-Combo
03 105880 RK	CITY	City	Duplex-Combo
04 112385 RK	R-5	Rural-5 Acre	Single Family Res-Combo
04 119656 RK	R-9,600	Residential 9,600 sq. ft.	Single Family Res-Combo
04 114085 RK	R-9,600	Residential 9,600 sq. ft.	SFR-Basic
04 100378 RK	R-9,600	Residential 9,600 sq. ft.	Single Family Res-Combo
04 118440 RK	R-9,600	Residential 9,600 sq. ft.	Single Family Res-Combo
04 109805 RK	R-9,600	Residential 9,600 sq. ft.	SFR-Basic
04 117286 RK	R-5	Rural-5 Acre	Single Family Res-Combo
02 110787 RK	R-8,400	Residential 8,400 sq. ft.	Duplex-Combo
04 118967 MH	R-5	Rural-5 Acre	Double Wide
04 100201 RK	LDMR	Low Density Multiple Reside	SFR-Basic
04 109415 RK	LDMR	Low Density Multiple Reside	SFR-Basic
04 116722 MH	R-5	Rural-5 Acre	Double Wide
04 111265 RK	LDMR	Low Density Multiple Reside	SFR-Basic
04 109410 RK	LDMR	Low Density Multiple Reside	SFR-Basic
04 108786 RK	LDMR	Low Density Multiple Reside	Single Family Res-Combo
04 108789 RK	LDMR	Low Density Multiple Reside	SFR-Basic



Accessory Dwelling Units

Index # - File Name: 1.0022 - Single Family Dwellings Data\_Snohomish County.pdf

04 100200 RK	LDMR	Low Density Multiple Reside	SFR-Basic
04 110320 RK	LDMR	Low Density Multiple Reside	SFR-Basic
04 109413 RK	LDMR	Low Density Multiple Reside	SFR-Basic
04 110321 RK	LDMR	Low Density Multiple Reside	SFR-Basic
04 100369 RK	CITY	City	SFR-Basic
04 109204 RK	R-5	Rural-5 Acre	Single Family Res-Combo
03 111048 RK	CITY	City	SFR-Basic
03 108085 RK	CITY	City	Single Family Res-Combo
03 107696 RK	R-5	Rural-5 Acre	SFR-Basic
03 107694 RK	R-5	Rural-5 Acre	SFR-Basic
03 106924 RK	R-5	Rural-5 Acre	Single Family Res-Combo
04 111076 RK	R-5	Rural-5 Acre	Single Family Res-Combo
04 109736 RK	CITY	City	SFR-Basic
04 109943 RK	CITY	City	SFR-Basic
04 110148 RK	CITY	City	SFR-Basic
04 100022 RK	CITY	City	SFR-Basic
03 109706 RK	CITY	City	Single Family Res-Combo
04 109947 RK	CITY	City	SFR-Basic
04 109922 RK	CITY	City	SFR-Basic
04 109954 RK	CITY	City	SFR-Basic
04 108615 RK	CITY	City	SFR-Basic
04 108864 RK	CITY	City	SFR-Basic
04 109734 RK	CITY	City	SFR-Basic
04 100166 RK	CITY	City	SFR-Basic
04 100167 RK	CITY	City	SFR-Basic
03 110894 RK	CITY	City	SFR-Basic
04 100011 MH	R-5	Rural-5 Acre	Double Wide
04 111487 RK	PRD-7,200	Residential 7,200 sq. ft.	SFR-Basic
04 111490 RK	PRD-7,200	Residential 7,200 sq. ft.	SFR-Basic
04 111493 RK	PRD-7,200	Residential 7,200 sq. ft.	SFR-Basic
04 111496 RK	PRD-7,200	Residential 7,200 sq. ft.	SFR-Basic
04 111494 RK	PRD-7,200	Residential 7,200 sq. ft.	SFR-Basic
04 108759 RK	PRD-7,200	Residential 7,200 sq. ft.	SFR-Basic
04 110521 RK	PRD-7,200	Residential 7,200 sq. ft.	SFR-Basic
04 110524 RK	PRD-7,200	Residential 7,200 sq. ft.	SFR-Basic
04 110523 RK	PRD-7,200	Residential 7,200 sq. ft.	SFR-Basic
04 108758 RK	PRD-7,200	Residential 7,200 sq. ft.	SFR-Basic
04 110519 RK	PRD-7,200	Residential 7,200 sq. ft.	SFR-Basic
04 110520 RK	PRD-7,200	Residential 7,200 sq. ft.	SFR-Basic
04 108756 RK	PRD-7,200	Residential 7,200 sq. ft.	SFR-Basic
04 108757 RK	PRD-7,200	Residential 7,200 sq. ft.	SFR-Basic
04 109713 RK	PRD-7,200	Residential 7,200 sq. ft.	SFR-Basic
04 109714 RK	PRD-7,200	Residential 7,200 sq. ft.	SFR-Basic
03 104430 RK	R-5	Rural-5 Acre	Single Family Res-Combo
04 115435 RK	R-9,600	Residential 9,600 sq. ft.	Single Family Res-Combo
03 109351 RK	R-5	Rural-5 Acre	Single Family Res-Combo
04 112512 RK	R-5	Rural-5 Acre	SFR-Basic

Accessory Dwelling Units

Index # - File Name: 1.0022 - Single Family Dwellings Data\_Snohomish County.pdf

04 115065 RK	R-5	Rural-5 Acre	Single Family Res-Combo
04 108748 RK	R-5	Rural-5 Acre	Single Family Res-Combo
04 115225 RK	R-5	Rural-5 Acre	Single Family Res-Combo
04 115438 RK	R-5	Rural-5 Acre	Single Family Res-Combo
04 110241 MH	F	Forestry	Double Wide
04 110651 RK	PRD-9,600	Residential 9,600 sq. ft.	SFR-Basic
04 110656 RK	PRD-9,600	Residential 9,600 sq. ft.	SFR-Basic
04 110567 RK	PRD-9,600	Residential 9,600 sq. ft.	SFR-Basic
04 110671 RK	PRD-9,600	Residential 9,600 sq. ft.	SFR-Basic
04 110664 RK	PRD-9,600	Residential 9,600 sq. ft.	SFR-Basic
04 110459 RK	PRD-9,600	Residential 9,600 sq. ft.	SFR-Basic
04 110461 RK	PRD-9,600	Residential 9,600 sq. ft.	SFR-Basic
04 110463 RK	PRD-9,600	Residential 9,600 sq. ft.	SFR-Basic
04 110672 RK	PRD-9,600	Residential 9,600 sq. ft.	SFR-Basic
04 110659 RK	PRD-9,600	Residential 9,600 sq. ft.	SFR-Basic
04 110660 RK	PRD-9,600	Residential 9,600 sq. ft.	SFR-Basic
03 107640 RK	R-5	Rural-5 Acre	Single Family Res-Combo
04 109548 RK	R-5	Rural-5 Acre	SFR-Basic
04 115154 RK	R-5	Rural-5 Acre	SFR-Basic
03 108729 RK	R-5	Rural-5 Acre	Single Family Res-Combo
04 112463 RK	R-5	Rural-5 Acre	Single Family Res-Combo
04 110533 RK	R-5	Rural-5 Acre	Single Family Res-Combo
04 108892 RK	CITY	City	SFR-Basic
03 106307 RK	R-5	Rural-5 Acre	Single Family Res-Combo
04 113502 RK	CITY	City	SFR-Basic
04 113778 RK	CITY	City	SFR-Basic
04 118064 RK	CITY	City	SFR-Basic
04 111825 RK	LDMR	Low Density Multiple Reside	SFR-Basic
04 112874 RK	LDMR	Low Density Multiple Reside	SFR-Basic
04 112875 RK	LDMR	Low Density Multiple Reside	Single Family Res-Combo
04 111827 RK	LDMR	Low Density Multiple Reside	SFR-Basic
04 100126 RK	LDMR	Low Density Multiple Reside	SFR-Basic
03 109098 RK	CITY	City	Single Family Res-Combo
03 111077 RK	CITY	City	SFR-Basic
03 111078 RK	CITY	City	SFR-Basic
03 111079 RK	CITY	City	SFR-Basic
04 113779 RK	CITY	City	SFR-Basic
04 115369 RK	CITY	City	SFR-Basic
04 115370 RK	CITY	City	SFR-Basic
04 112900 RK	CITY	City	SFR-Basic
04 112220 RK	CITY	City	SFR-Basic
04 111338 RK	CITY	City	SFR-Basic
04 111340 RK	CITY	City	SFR-Basic
04 111166 RK	CITY	City	SFR-Basic
04 111835 RK	CITY	City	SFR-Basic
04 115371 RK	CITY	City	SFR-Basic
04 117493 RK	CITY	City	SFR-Basic

Accessory Dwelling Units

Index # - File Name: 1.0022 - Single Family Dwellings Data\_Snohomish County.pdf

04 109903 RK	CITY	City	SFR-Basic
04 110479 RK	CITY	City	SFR-Basic
04 116553 RK	CITY	City	SFR-Basic
04 112460 RK	CITY	City	SFR-Basic
04 112461 RK	CITY	City	SFR-Basic
04 116615 RK	CITY	City	SFR-Basic
04 111337 RK	CITY	City	SFR-Basic
04 111968 RK	CITY	City	SFR-Basic
04 109686 RK	CITY	City	SFR-Basic
04 110164 RK	CITY	City	SFR-Basic
04 109321 RK	CITY	City	SFR-Basic
04 110472 RK	CITY	City	SFR-Basic
04 110161 RK	CITY	City	SFR-Basic
04 110162 RK	CITY	City	SFR-Basic
04 109898 RK	CITY	City	SFR-Basic
04 109152 RK	CITY	City	SFR-Basic
04 109153 RK	CITY	City	SFR-Basic
04 109900 RK	CITY	City	SFR-Basic
04 109154 RK	CITY	City	SFR-Basic
04 110474 RK	CITY	City	SFR-Basic
04 108891 RK	CITY	City	SFR-Basic
04 115357 RK	CITY	City	SFR-Basic
04 100128 RK	LDMR	Low Density Multiple Reside	SFR-Basic
04 109593 RK	LDMR	Low Density Multiple Reside	SFR-Basic
04 111031 RK	LDMR	Low Density Multiple Reside	SFR-Basic
04 115073 RK	LDMR	Low Density Multiple Reside	SFR-Basic
04 115074 RK	LDMR	Low Density Multiple Reside	SFR-Basic
04 115077 RK	LDMR	Low Density Multiple Reside	SFR-Basic
04 115076 RK	LDMR	Low Density Multiple Reside	SFR-Basic
04 115078 RK	LDMR	Low Density Multiple Reside	SFR-Basic
04 112872 RK	LDMR	Low Density Multiple Reside	SFR-Basic
04 115075 RK	LDMR	Low Density Multiple Reside	SFR-Basic
04 112873 RK	LDMR	Low Density Multiple Reside	SFR-Basic
04 111824 RK	LDMR	Low Density Multiple Reside	SFR-Basic
04 109592 RK	LDMR	Low Density Multiple Reside	SFR-Basic
04 109590 RK	LDMR	Low Density Multiple Reside	SFR-Basic
04 117943 RK	R-7,200	Residential 7,200 sq. ft.	SFR-Basic
04 110655 RK	R-7,200	Residential 7,200 sq. ft.	SFR-Basic
04 114906 MH	RD	Rural Diversification	Double Wide
04 118487 RK	RD	Rural Diversification	Single Family Res-Combo
03 109121 RK	R-5	Rural-5 Acre	Single Family Res-Combo
04 112901 RK	CITY	City	SFR-Basic
04 115156 RK	R-5	Rural-5 Acre	Single Family Res-Combo
04 100185 RK	R-7,200	Residential 7,200 sq. ft.	SFR-Basic
04 100179 RK	R-7,200	Residential 7,200 sq. ft.	SFR-Basic
04 100181 RK	R-7,200	Residential 7,200 sq. ft.	SFR-Basic
04 108991 RK	R-5	Rural-5 Acre	Single Family Res-Combo

Accessory Dwelling Units

Index # - File Name: 1.0022 - Single Family Dwellings Data\_Snohomish County.pdf

04 110434 RK	R-5	Rural-5 Acre	Single Family Res-Combo
03 110400 RK	R-9,600	Residential 9,600 sq. ft.	Single Family Res-Combo
04 111797 RK	R-9,600	Residential 9,600 sq. ft.	Single Family Res-Combo
04 111796 RK	R-9,600	Residential 9,600 sq. ft.	Single Family Res-Combo
03 111128 RK	R-9,600	Residential 9,600 sq. ft.	Single Family Res-Combo
03 108772 RK	A-10 : R-5	Agriculture-10 Acre : Rural-5	Single Family Res-Combo
04 109071 RK	CITY	City	Single Family Res-Combo
04 114835 RK	R-5	Rural-5 Acre	Single Family Res-Combo
04 111950 RK	R-5	Rural-5 Acre	SFR-Basic
04 109181 RK	R-5	Rural-5 Acre	Single Family Res-Combo
04 111282 RK	R-5	Rural-5 Acre	Single Family Res-Combo
04 111286 RK	R-5	Rural-5 Acre	Single Family Res-Combo
04 113977 RK	R-5	Rural-5 Acre	Single Family Res-Combo
04 113459 RK	R-5	Rural-5 Acre	Single Family Res-Combo
04 115070 RK	R-5	Rural-5 Acre	Single Family Res-Combo
04 100133 RK	R-5	Rural-5 Acre	Single Family Res-Combo
04 120253 RK	R-5	Rural-5 Acre	Single Family Res-Combo
04 112546 RK	R-5	Rural-5 Acre	Single Family Res-Combo
04 109363 RK	R-5	Rural-5 Acre	SFR-Basic
04 109318 RK	R-5	Rural-5 Acre	SFR-Basic
04 108626 RK	R-5	Rural-5 Acre	Single Family Res-Combo
04 110039 RK	R-5	Rural-5 Acre	Single Family Res-Combo
04 100093 RK	R-5	Rural-5 Acre	Single Family Res-Combo
04 110332 RK	R-5	Rural-5 Acre	Single Family Res-Combo
04 121032 RK	R-5	Rural-5 Acre	Single Family Res-Combo
03 110638 RK	R-5	Rural-5 Acre	Single Family Res-Combo
04 117158 RK	R-5	Rural-5 Acre	Single Family Res-Combo
04 116827 RK	R-5	Rural-5 Acre	Single Family Res-Combo
03 109499 RK	R-5	Rural-5 Acre	Single Family Res-Combo
03 110932 RK	R-5	Rural-5 Acre	Single Family Res-Combo
04 108968 RK	R-5	Rural-5 Acre	Single Family Res-Combo
04 112352 RK	R-5	Rural-5 Acre	Single Family Res-Combo
04 116247 RK	R-5	Rural-5 Acre	Single Family Res-Combo
04 117306 RK	R-5	Rural-5 Acre	SFR-Basic
04 112085 RK	A-10	Agriculture-10 Acre	SFR-Basic
04 113711 RK	R-5	Rural-5 Acre	Single Family Res-Combo
04 113681 RK	R-5	Rural-5 Acre	Single Family Res-Combo
03 108759 RK	RC	Rural Conservation	Single Family Res-Combo
04 114553 RK	CITY	City	SFR-Basic
04 114558 RK	CITY	City	SFR-Basic
04 115071 RK	CITY	City	Single Family Res-Combo
04 116030 RK	CITY	City	Single Family Res-Combo
04 114555 RK	CITY	City	SFR-Basic
04 109613 RK	CITY	City	SFR-Basic
04 118847 RK	CITY	City	Single Family Res-Combo
04 118851 RK	CITY	City	Single Family Res-Combo
04 100310 RK	CITY	City	SFR-Basic

Accessory Dwelling Units

Index # - File Name: 1.0022 - Single Family Dwellings Data\_Snohomish County.pdf

04 111309 RK	CITY	City	SFR-Basic
04 111312 RK	CITY	City	SFR-Basic
04 100308 RK	CITY	City	SFR-Basic
03 110468 RK	CITY	City	Single Family Res-Combo
04 114559 RK	CITY	City	SFR-Basic
04 114468 RK	CITY	City	Single Family Res-Combo
04 114557 RK	CITY	City	SFR-Basic
04 113436 RK	CITY	City	Single Family Res-Combo
04 119090 RK	R-9,600	Residential 9,600 sq. ft.	Single Family Res-Combo
04 120280 RK	R-9,600	Residential 9,600 sq. ft.	SFR-Basic
04 112492 RK	R-9,600	Residential 9,600 sq. ft.	Single Family Res-Combo
04 117939 RK	R-9,600	Residential 9,600 sq. ft.	Single Family Res-Combo
04 116927 RK	R-9,600	Residential 9,600 sq. ft.	SFR-Basic
04 113762 RK	R-9,600	Residential 9,600 sq. ft.	SFR-Basic
04 111081 RK	R-9,600	Residential 9,600 sq. ft.	Single Family Res-Combo
04 118550 RK	R-9,600	Residential 9,600 sq. ft.	SFR-Basic
04 112853 RK	R-9,600	Residential 9,600 sq. ft.	SFR-Basic
04 116926 RK	R-9,600	Residential 9,600 sq. ft.	SFR-Basic
04 120788 RK	R-9,600	Residential 9,600 sq. ft.	Single Family Res-Combo
04 112854 RK	R-9,600	Residential 9,600 sq. ft.	Single Family Res-Combo
04 116921 RK	R-9,600	Residential 9,600 sq. ft.	Single Family Res-Combo
04 117412 RK	R-9,600	Residential 9,600 sq. ft.	Single Family Res-Combo
04 118578 RK	R-9,600	Residential 9,600 sq. ft.	Single Family Res-Combo
04 118577 RK	R-9,600	Residential 9,600 sq. ft.	SFR-Basic
04 117197 RK	R-5	Rural-5 Acre	Single Family Res-Combo
04 118782 RK	R-5	Rural-5 Acre	Single Family Res-Combo
04 113571 RK	R-5	Rural-5 Acre	Single Family Res-Combo
04 120787 RK	R-9,600	Residential 9,600 sq. ft.	Single Family Res-Combo
03 108794 RK	R-5	Rural-5 Acre	Single Family Res-Combo
03 110299 RK	CITY	City	Duplex-Basic
04 118587 MH	R-8,400	Residential 8,400 sq. ft.	Double Wide
04 110508 RK	R-9,600	Residential 9,600 sq. ft.	SFR-Basic
04 109710 RK	R-9,600	Residential 9,600 sq. ft.	Single Family Res-Combo
04 110509 RK	R-9,600	Residential 9,600 sq. ft.	SFR-Basic
04 115400 RK	R-9,600	Residential 9,600 sq. ft.	SFR-Basic
04 115396 RK	R-9,600	Residential 9,600 sq. ft.	SFR-Basic
04 109213 RK	R-9,600	Residential 9,600 sq. ft.	SFR-Basic
04 111649 RK	R-9,600	Residential 9,600 sq. ft.	SFR-Basic
04 117408 RK	R-9,600	Residential 9,600 sq. ft.	Single Family Res-Combo
04 111116 RK	R-9,600	Residential 9,600 sq. ft.	SFR-Basic
02 105681 000 01 MH	R-5	Rural-5 Acre	Double Wide
04 100171 RK	CITY	City	SFR-Basic
04 110883 RK	CITY	City	Single Family Res-Combo
04 108542 RK	R-5	Rural-5 Acre	Single Family Res-Combo
04 100259 RK	R-5	Rural-5 Acre	Single Family Res-Combo
04 109091 RK	CITY	City	SFR-Basic
04 112852 RK	R-9,600	Residential 9,600 sq. ft.	SFR-Basic

Accessory Dwelling Units

Index # - File Name: 1.0022 - Single Family Dwellings Data\_Snohomish County.pdf

04 109092 RK	CITY	City	SFR-Basic
04 114948 RK	CITY	City	Single Family Res-Combo
04 114958 RK	CITY	City	Single Family Res-Combo
04 111344 RK	CITY	City	SFR-Basic
04 111348 RK	CITY	City	SFR-Basic
04 111480 RK	R-5	Rural-5 Acre	Single Family Res-Combo
03 110950 RK	R-5	Rural-5 Acre	SFR-Basic
04 109719 RK	R-5	Rural-5 Acre	Single Family Res-Combo
04 100141 RK	PRD-9,600	Residential 9,600 sq. ft.	SFR-Basic
04 108622 RK	CITY	City	SFR-Basic
03 109708 MH	R-5	Rural-5 Acre	Single Wide
04 119080 RK	R-9,600	Residential 9,600 sq. ft.	Single Family Res-Combo
04 109089 RK	R-5	Rural-5 Acre	Single Family Res-Combo
04 113317 RK	R-5	Rural-5 Acre	Single Family Res-Combo
04 112466 RK	CITY	City	SFR-Basic
04 114055 RK	CITY	City	SFR-Basic
04 119046 RK	CITY	City	SFR-Basic
04 109322 RK	CITY	City	SFR-Basic
04 113724 RK	R-5	Rural-5 Acre	Single Family Res-Combo
03 109543 RK	R-7,200	Residential 7,200 sq. ft.	Single Family Res-Combo
04 112902 RK	CITY	City	SFR-Basic
04 116619 RK	CITY	City	SFR-Basic
04 117736 RK	CITY	City	SFR-Basic
04 117734 RK	CITY	City	SFR-Basic
04 110387 RK	CITY	City	SFR-Basic
04 116180 RK	CITY	City	SFR-Basic
04 112438 RK	CITY	City	SFR-Basic
04 115196 RK	CITY	City	SFR-Basic
04 116181 RK	CITY	City	SFR-Basic
04 113741 RK	CITY	City	SFR-Basic
04 116096 RK	CITY	City	SFR-Basic
04 113017 RK	CITY	City	SFR-Basic
04 117612 RK	CITY	City	SFR-Basic
04 118693 RK	CITY	City	SFR-Basic
04 118527 RK	CITY	City	SFR-Basic
04 116466 RK	CITY	City	SFR-Basic
04 114712 RK	CITY	City	SFR-Basic
04 111193 RK	CITY	City	SFR-Basic
04 109639 RK	CITY	City	SFR-Basic
04 109311 RK	CITY	City	SFR-Basic
04 109313 RK	CITY	City	SFR-Basic
04 109309 RK	CITY	City	SFR-Basic
04 109316 RK	CITY	City	SFR-Basic
04 110389 RK	CITY	City	SFR-Basic
04 110392 RK	CITY	City	SFR-Basic
04 110597 RK	CITY	City	SFR-Basic
04 110599 RK	CITY	City	SFR-Basic

Accessory Dwelling Units

Index # - File Name: 1.0022 - Single Family Dwellings Data\_Snohomish County.pdf

04 111626 RK	CITY	City	SFR-Basic
04 111627 RK	CITY	City	SFR-Basic
04 111625 RK	CITY	City	SFR-Basic
04 111569 RK	CITY	City	SFR-Basic
04 115882 RK	CITY	City	SFR-Basic
04 115879 RK	CITY	City	SFR-Basic
04 113742 RK	CITY	City	SFR-Basic
04 113743 RK	CITY	City	SFR-Basic
04 112434 RK	CITY	City	SFR-Basic
04 112437 RK	CITY	City	SFR-Basic
04 112439 RK	CITY	City	SFR-Basic
04 112440 RK	CITY	City	SFR-Basic
04 114710 RK	CITY	City	SFR-Basic
04 114708 RK	CITY	City	SFR-Basic
04 114794 RK	CITY	City	SFR-Basic
04 114796 RK	CITY	City	SFR-Basic
04 116095 RK	CITY	City	SFR-Basic
04 116093 RK	CITY	City	SFR-Basic
04 116378 RK	CITY	City	SFR-Basic
04 116380 RK	CITY	City	SFR-Basic
04 117478 RK	CITY	City	SFR-Basic
04 117479 RK	CITY	City	SFR-Basic
04 118439 RK	CITY	City	SFR-Basic
04 118441 RK	CITY	City	SFR-Basic
03 111061 RK	CITY	City	SFR-Basic
03 111062 RK	CITY	City	SFR-Basic
04 109312 RK	CITY	City	SFR-Basic
04 109314 RK	CITY	City	SFR-Basic
04 110586 RK	CITY	City	SFR-Basic
04 110588 RK	CITY	City	SFR-Basic
04 110590 RK	CITY	City	SFR-Basic
04 110593 RK	CITY	City	SFR-Basic
04 110595 RK	CITY	City	SFR-Basic
04 100396 RK	R-5	Rural-5 Acre	SFR-Basic
04 108875 RK	R-5	Rural-5 Acre	SFR-Basic
04 118181 RK	RRT-10	Rural Resource Transition-10	Single Family Res-Combo
03 103449 RK	R-5	Rural-5 Acre	Single Family Res-Combo
04 100080 RK	R-5	Rural-5 Acre	Single Family Res-Combo
04 118971 MH	R-5	Rural-5 Acre	Single Wide
04 115273 RK	R-7,200	Residential 7,200 sq. ft.	SFR-Basic
04 115274 RK	R-7,200	Residential 7,200 sq. ft.	SFR-Basic
04 115279 RK	R-7,200	Residential 7,200 sq. ft.	SFR-Basic
04 115276 RK	R-7,200	Residential 7,200 sq. ft.	SFR-Basic
04 114240 RK	R-7,200	Residential 7,200 sq. ft.	Single Family Res-Combo
04 112926 RK	R-7,200	Residential 7,200 sq. ft.	SFR-Basic
04 110119 RK	R-7,200	Residential 7,200 sq. ft.	SFR-Basic
04 115054 RK	R-7,200	Residential 7,200 sq. ft.	Single Family Res-Combo

Accessory Dwelling Units

Index # - File Name: 1.0022 - Single Family Dwellings Data\_Snohomish County.pdf

04 114238 RK	R-7,200	Residential 7,200 sq. ft.	Single Family Res-Combo
04 110115 RK	R-7,200	Residential 7,200 sq. ft.	SFR-Basic
04 118094 RK	R-7,200	Residential 7,200 sq. ft.	Single Family Res-Combo
04 110176 RK	R-7,200	Residential 7,200 sq. ft.	SFR-Basic
04 109017 RK	R-7,200	Residential 7,200 sq. ft.	SFR-Basic
04 112931 RK	R-7,200	Residential 7,200 sq. ft.	SFR-Basic
04 110981 RK	R-7,200	Residential 7,200 sq. ft.	Single Family Res-Combo
04 114239 RK	R-7,200	Residential 7,200 sq. ft.	Single Family Res-Combo
04 109019 RK	R-7,200	Residential 7,200 sq. ft.	Single Family Res-Combo
04 109398 RK	R-7,200	Residential 7,200 sq. ft.	SFR-Basic
04 110569 RK	R-5	Rural-5 Acre	Single Family Res-Combo
04 114237 RK	R-7,200	Residential 7,200 sq. ft.	Single Family Res-Combo
04 111639 RK	R-7,200	Residential 7,200 sq. ft.	SFR-Basic
04 100228 RK	R-7,200	Residential 7,200 sq. ft.	Single Family Res-Combo
04 110346 RK	R-5	Rural-5 Acre	Single Family Res-Combo
04 116522 RK	R-5	Rural-5 Acre	Single Family Res-Combo
04 100254 RK	R-5	Rural-5 Acre	Single Family Res-Combo
04 109167 RK	R-5	Rural-5 Acre	Single Family Res-Combo
04 108881 RK	R-5	Rural-5 Acre	Single Family Res-Combo
04 108651 MH	R-5	Rural-5 Acre	Double Wide
02 109604 MH	R-5	Rural-5 Acre	Double Wide
03 108911 RK	R-5	Rural-5 Acre	Single Family Res-Combo
04 117595 RK	R-5	Rural-5 Acre	Single Family Res-Combo
03 107907 RK	PRD-9,600	Residential 9,600 sq. ft.	SFR-Basic
03 107904 RK	PRD-9,600	Residential 9,600 sq. ft.	SFR-Basic
03 107909 RK	PRD-9,600	Residential 9,600 sq. ft.	SFR-Basic
03 107903 RK	PRD-9,600	Residential 9,600 sq. ft.	SFR-Basic
03 107899 RK	PRD-9,600	Residential 9,600 sq. ft.	SFR-Basic
04 109295 RK	RRT-10	Rural Resource Transition-1	Single Family Res-Combo
04 111001 RK	RRT-10	Rural Resource Transition-1	Single Family Res-Combo
04 114655 RK	RRT-10	Rural Resource Transition-1	Single Family Res-Combo
04 115433 RK	RRT-10	Rural Resource Transition-1	Single Family Res-Combo
04 113753 RK	RRT-10	Rural Resource Transition-1	Single Family Res-Combo
04 117176 RK	RRT-10	Rural Resource Transition-1	SFR-Basic
04 118074 RK	RRT-10	Rural Resource Transition-1	SFR-Basic
04 117177 RK	RRT-10	Rural Resource Transition-1	SFR-Basic
04 115207 RK	RRT-10	Rural Resource Transition-1	Single Family Res-Combo
04 110908 RK	RRT-10	Rural Resource Transition-1	Single Family Res-Combo
04 111322 RK	RRT-10	Rural Resource Transition-1	Single Family Res-Combo
04 113754 RK	RRT-10	Rural Resource Transition-1	SFR-Basic
04 114656 RK	RRT-10	Rural Resource Transition-1	Single Family Res-Combo
04 118158 RK	RRT-10	Rural Resource Transition-1	Single Family Res-Combo
04 110947 RK	RRT-10	Rural Resource Transition-1	Single Family Res-Combo
04 118001 RK	RRT-10	Rural Resource Transition-1	Single Family Res-Combo
03 111055 RK	RRT-10	Rural Resource Transition-1	Single Family Res-Combo
04 114825 RK	RRT-10	Rural Resource Transition-1	Single Family Res-Combo
04 114647 RK	RRT-10	Rural Resource Transition-1	Single Family Res-Combo



Accessory Dwelling Units

Index # - File Name: 1.0022 - Single Family Dwellings Data\_Snohomish County.pdf

04 114774 RK	RRT-10	Rural Resource Transition-1(Single Family Res-Combo	
04 110951 RK	RRT-10	Rural Resource Transition-1(Single Family Res-Combo	
03 104527 RK	PRD-9,600	Residential 9,600 sq. ft.	Single Family Res-Combo
04 114918 RK	R-5	Rural-5 Acre	Single Family Res-Combo
04 111536 RK	R-5	Rural-5 Acre	Single Family Res-Combo
04 100383 RK	R-5	Rural-5 Acre	SFR-Basic
04 111464 RK	R-5	Rural-5 Acre	Single Family Res-Combo
04 112428 RK	R-5	Rural-5 Acre	SFR-Basic
04 116277 RK	RRT-10	Rural Resource Transition-1(Single Family Res-Combo	
04 111568 RK	RRT-10	Rural Resource Transition-1(Single Family Res-Combo	
04 115205 RK	A-10 : R-5	Agriculture-10 Acre : Rural-5	Single Family Res-Combo
04 113562 RK	PRD-7,200	Residential 7,200 sq. ft.	SFR-Basic
04 120346 RK	PRD-7,200	Residential 7,200 sq. ft.	SFR-Basic
04 113563 RK	PRD-7,200	Residential 7,200 sq. ft.	SFR-Basic
04 113557 RK	PRD-7,200	Residential 7,200 sq. ft.	SFR-Basic
04 113558 RK	PRD-7,200	Residential 7,200 sq. ft.	SFR-Basic
04 113565 RK	PRD-7,200	Residential 7,200 sq. ft.	SFR-Basic
04 113564 RK	PRD-7,200	Residential 7,200 sq. ft.	SFR-Basic
04 112991 RK	A-10	Agriculture-10 Acre	Single Family Res-Combo
04 114586 RK	R-5	Rural-5 Acre	Single Family Res-Combo
04 114587 RK	R-5	Rural-5 Acre	Single Family Res-Combo
04 117998 RK	R-7,200	Residential 7,200 sq. ft.	Single Family Res-Combo
04 120174 RK	R-7,200	Residential 7,200 sq. ft.	Single Family Res-Combo
04 117996 RK	R-7,200	Residential 7,200 sq. ft.	Single Family Res-Combo
04 118507 RK	R-7,200	Residential 7,200 sq. ft.	Single Family Res-Combo
04 118754 RK	R-5	Rural-5 Acre	Single Family Res-Combo
04 113848 RK	R-5	Rural-5 Acre	Single Family Res-Combo
04 116968 RK	R-5	Rural-5 Acre	SFR-Basic
04 116376 RK	R-5	Rural-5 Acre	Single Family Res-Combo
04 116381 RK	R-5	Rural-5 Acre	Single Family Res-Combo
04 116307 RK	R-5	Rural-5 Acre	Single Family Res-Combo
04 115899 RK	R-5	Rural-5 Acre	SFR-Basic
04 115897 RK	R-5	Rural-5 Acre	SFR-Basic
04 119559 RK	R-5	Rural-5 Acre	SFR-Basic
04 119562 RK	R-5	Rural-5 Acre	SFR-Basic
04 119560 RK	R-5	Rural-5 Acre	SFR-Basic
04 119751 RK	R-5	Rural-5 Acre	SFR-Basic
04 115898 RK	R-5	Rural-5 Acre	SFR-Basic
04 114696 RK	R-5	Rural-5 Acre	SFR-Basic
04 114693 RK	R-5	Rural-5 Acre	SFR-Basic
04 118619 RK	R-5	Rural-5 Acre	Single Family Res-Combo
04 114094 RK	CITY	City	SFR-Basic
04 114097 RK	CITY	City	SFR-Basic
04 114098 RK	CITY	City	SFR-Basic
04 114101 RK	CITY	City	SFR-Basic
04 114110 RK	CITY	City	SFR-Basic
04 114115 RK	CITY	City	SFR-Basic

Accessory Dwelling Units

Index # - File Name: 1.0022 - Single Family Dwellings Data\_Snohomish County.pdf

04 114116 RK	CITY	City	SFR-Basic
04 114120 RK	CITY	City	SFR-Basic
04 114121 RK	CITY	City	SFR-Basic
04 118948 RK	CITY	City	SFR-Basic
04 118949 RK	CITY	City	Single Family Res-Combo
04 114127 RK	CITY	City	SFR-Basic
04 113837 RK	CITY	City	SFR-Basic
04 113808 RK	CITY	City	SFR-Basic
04 113809 RK	CITY	City	SFR-Basic
04 113838 RK	CITY	City	SFR-Basic
04 113810 RK	CITY	City	SFR-Basic
04 113839 RK	CITY	City	SFR-Basic
04 113811 RK	CITY	City	SFR-Basic
04 113840 RK	CITY	City	SFR-Basic
04 113812 RK	CITY	City	SFR-Basic
04 113813 RK	CITY	City	SFR-Basic
04 113841 RK	CITY	City	SFR-Basic
04 113313 RK	R-5	Rural-5 Acre	Single Family Res-Combo
04 113315 RK	R-5	Rural-5 Acre	Single Family Res-Combo
04 113411 RK	R-5	Rural-5 Acre	Single Family Res-Combo
04 113451 RK	R-5	Rural-5 Acre	Single Family Res-Combo
04 113453 RK	R-5	Rural-5 Acre	Single Family Res-Combo
04 118000 RK	R-7,200	Residential 7,200 sq. ft.	Single Family Res-Combo
04 117999 RK	R-7,200	Residential 7,200 sq. ft.	Single Family Res-Combo
04 117101 RK	R-7,200	Residential 7,200 sq. ft.	Single Family Res-Combo
04 120269 RK	R-7,200	Residential 7,200 sq. ft.	Single Family Res-Combo
04 120267 RK	R-7,200	Residential 7,200 sq. ft.	Single Family Res-Combo
04 118509 RK	R-7,200	Residential 7,200 sq. ft.	Single Family Res-Combo
04 117997 RK	R-7,200	Residential 7,200 sq. ft.	Single Family Res-Combo
04 116781 RK	R-7,200	Residential 7,200 sq. ft.	Single Family Res-Combo
04 117375 RK	R-5	Rural-5 Acre	SFR-Basic
04 115202 RK	R-5	Rural-5 Acre	Single Family Res-Combo
04 115250 RK	R-5	Rural-5 Acre	Single Family Res-Combo
04 115240 RK	R-5	Rural-5 Acre	Single Family Res-Combo
04 115260 RK	R-5	Rural-5 Acre	SFR-Basic
04 117250 RK	R-5	Rural-5 Acre	Single Family Res-Combo
04 115264 RK	R-5	Rural-5 Acre	SFR-Basic
04 114275 RK	R-5	Rural-5 Acre	Single Family Res-Combo
04 113088 RK	R-5	Rural-5 Acre	Single Family Res-Combo
04 115129 RK	R-5	Rural-5 Acre	SFR-Basic
04 114770 RK	R-5	Rural-5 Acre	Single Family Res-Combo
04 119557 RK	R-5	Rural-5 Acre	SFR-Basic
04 113788 RK	R-5	Rural-5 Acre	Single Family Res-Combo
04 113787 RK	R-5	Rural-5 Acre	Single Family Res-Combo
04 117376 RK	R-5	Rural-5 Acre	SFR-Basic
04 114634 RK	RRT-10	Rural Resource Transition-10	Single Family Res-Combo
04 118586 RK	R-9,600	Residential 9,600 sq. ft.	Single Family Res-Combo

Accessory Dwelling Units

Index # - File Name: 1.0022 - Single Family Dwellings Data\_Snohomish County.pdf

04 114615 RK	R-9,600	Residential 9,600 sq. ft.	SFR-Basic
04 118747 RK	R-9,600	Residential 9,600 sq. ft.	Single Family Res-Combo
04 114619 RK	R-9,600	Residential 9,600 sq. ft.	SFR-Basic
04 114620 RK	R-9,600	Residential 9,600 sq. ft.	SFR-Basic
04 114622 RK	R-9,600	Residential 9,600 sq. ft.	SFR-Basic
04 114624 RK	R-9,600	Residential 9,600 sq. ft.	SFR-Basic
04 114628 RK	R-9,600	Residential 9,600 sq. ft.	SFR-Basic
04 118748 RK	R-9,600	Residential 9,600 sq. ft.	Single Family Res-Combo
04 116581 RK	R-9,600	Residential 9,600 sq. ft.	SFR-Basic
04 115026 RK	R-9,600	Residential 9,600 sq. ft.	SFR-Basic
04 115764 RK	R-9,600	Residential 9,600 sq. ft.	SFR-Basic
04 115762 RK	R-9,600	Residential 9,600 sq. ft.	SFR-Basic
04 115029 RK	R-9,600	Residential 9,600 sq. ft.	SFR-Basic
04 117617 RK	R-9,600	Residential 9,600 sq. ft.	SFR-Basic
04 118796 RK	R-9,600	Residential 9,600 sq. ft.	SFR-Basic
04 116583 RK	R-9,600	Residential 9,600 sq. ft.	SFR-Basic
04 117299 RK	R-9,600	Residential 9,600 sq. ft.	Single Family Res-Combo
04 114629 RK	R-9,600	Residential 9,600 sq. ft.	SFR-Basic
04 118588 RK	R-9,600	Residential 9,600 sq. ft.	Single Family Res-Combo
04 120316 RK	R-9,600	Residential 9,600 sq. ft.	Single Family Res-Combo
04 116575 RK	R-9,600	Residential 9,600 sq. ft.	SFR-Basic
04 115766 RK	R-9,600	Residential 9,600 sq. ft.	SFR-Basic
04 116463 RK	R-9,600	Residential 9,600 sq. ft.	Single Family Res-Combo
04 120825 RK	R-9,600	Residential 9,600 sq. ft.	Single Family Res-Combo
04 120829 RK	R-9,600	Residential 9,600 sq. ft.	Single Family Res-Combo
04 116460 RK	R-9,600	Residential 9,600 sq. ft.	Single Family Res-Combo
04 120317 RK	R-9,600	Residential 9,600 sq. ft.	Single Family Res-Combo
04 116779 RK	R-9,600	Residential 9,600 sq. ft.	Single Family Res-Combo
04 115350 RK	R-9,600	Residential 9,600 sq. ft.	Single Family Res-Combo
04 115358 RK	R-9,600	Residential 9,600 sq. ft.	Single Family Res-Combo
04 115359 RK	R-9,600	Residential 9,600 sq. ft.	Single Family Res-Combo
04 115362 RK	R-9,600	Residential 9,600 sq. ft.	Single Family Res-Combo
04 115368 RK	R-9,600	Residential 9,600 sq. ft.	Single Family Res-Combo
04 113736 RK	R-5	Rural-5 Acre	Single Family Res-Combo
04 113846 RK	WFB	Waterfront Beach	Single Family Res-Combo
04 115262 RK	RD	Rural Diversification	Single Family Res-Combo
04 114016 RK	R-5	Rural-5 Acre	Single Family Res-Combo
04 114026 RK	CITY	City	Duplex-Basic
04 114027 RK	CITY	City	Duplex-Basic
04 114028 RK	CITY	City	Duplex-Basic
04 114053 RK	R-5	Rural-5 Acre	SFR-Basic
04 114311 RK	R-9,600	Residential 9,600 sq. ft.	Single Family Res-Combo
04 115110 RK	R-9,600	Residential 9,600 sq. ft.	Single Family Res-Combo
03 102605 RK	R-9,600	Residential 9,600 sq. ft.	Single Family Res-Combo
04 114312 RK	R-9,600	Residential 9,600 sq. ft.	Single Family Res-Combo
04 114313 RK	R-9,600	Residential 9,600 sq. ft.	Single Family Res-Combo
04 114314 RK	R-9,600	Residential 9,600 sq. ft.	Single Family Res-Combo

Accessory Dwelling Units

Index # - File Name: 1.0022 - Single Family Dwellings Data\_Snohomish County.pdf

04 114315 RK	R-9,600	Residential 9,600 sq. ft.	Single Family Res-Combo
04 115030 RK	R-9,600	Residential 9,600 sq. ft.	Single Family Res-Combo
04 113688 RK	R-9,600	Residential 9,600 sq. ft.	Single Family Res-Combo
04 115337 RK	R-9,600	Residential 9,600 sq. ft.	Single Family Res-Combo
04 115025 RK	R-9,600	Residential 9,600 sq. ft.	Single Family Res-Combo
04 113692 RK	R-9,600	Residential 9,600 sq. ft.	Single Family Res-Combo
04 115028 RK	R-9,600	Residential 9,600 sq. ft.	Single Family Res-Combo
04 113696 RK	R-9,600	Residential 9,600 sq. ft.	Single Family Res-Combo
04 113697 RK	R-9,600	Residential 9,600 sq. ft.	Single Family Res-Combo
04 114689 RK	R-9,600	Residential 9,600 sq. ft.	Single Family Res-Combo
04 115032 RK	R-9,600	Residential 9,600 sq. ft.	Single Family Res-Combo
04 113689 RK	R-9,600	Residential 9,600 sq. ft.	Single Family Res-Combo
04 115031 RK	R-9,600	Residential 9,600 sq. ft.	Single Family Res-Combo
04 115217 RK	R-9,600	Residential 9,600 sq. ft.	Single Family Res-Combo
04 115222 RK	R-9,600	Residential 9,600 sq. ft.	Single Family Res-Combo
04 115218 RK	R-9,600	Residential 9,600 sq. ft.	Single Family Res-Combo
04 115226 RK	R-9,600	Residential 9,600 sq. ft.	Single Family Res-Combo
04 115220 RK	R-9,600	Residential 9,600 sq. ft.	Single Family Res-Combo
04 115224 RK	R-9,600	Residential 9,600 sq. ft.	Single Family Res-Combo
04 113876 RK	R-9,600	Residential 9,600 sq. ft.	Single Family Res-Combo
04 112622 RK	R-9,600	Residential 9,600 sq. ft.	Single Family Res-Combo
04 112619 RK	R-9,600	Residential 9,600 sq. ft.	Single Family Res-Combo
04 112621 RK	R-9,600	Residential 9,600 sq. ft.	Single Family Res-Combo
04 112620 RK	R-9,600	Residential 9,600 sq. ft.	Single Family Res-Combo
04 120658 RK	R-9,600	Residential 9,600 sq. ft.	Single Family Res-Combo
04 120656 RK	R-9,600	Residential 9,600 sq. ft.	Single Family Res-Combo
04 120655 RK	R-9,600	Residential 9,600 sq. ft.	Single Family Res-Combo
04 120654 RK	R-9,600	Residential 9,600 sq. ft.	Single Family Res-Combo
04 115113 RK	R-9,600	Residential 9,600 sq. ft.	Single Family Res-Combo
04 115105 RK	R-9,600	Residential 9,600 sq. ft.	Single Family Res-Combo
04 115118 RK	R-9,600	Residential 9,600 sq. ft.	Single Family Res-Combo
04 115121 RK	R-9,600	Residential 9,600 sq. ft.	Single Family Res-Combo
04 115213 RK	R-9,600	Residential 9,600 sq. ft.	Single Family Res-Combo
04 115215 RK	R-9,600	Residential 9,600 sq. ft.	Single Family Res-Combo
04 115120 RK	R-9,600	Residential 9,600 sq. ft.	Single Family Res-Combo
04 115103 RK	R-9,600	Residential 9,600 sq. ft.	Single Family Res-Combo
04 115233 RK	R-9,600	Residential 9,600 sq. ft.	Single Family Res-Combo
04 115229 RK	R-9,600	Residential 9,600 sq. ft.	Single Family Res-Combo
04 115228 RK	R-9,600	Residential 9,600 sq. ft.	Single Family Res-Combo
04 115336 RK	R-9,600	Residential 9,600 sq. ft.	Single Family Res-Combo
04 115122 RK	R-9,600	Residential 9,600 sq. ft.	Single Family Res-Combo
04 115107 RK	R-9,600	Residential 9,600 sq. ft.	Single Family Res-Combo
04 115216 RK	R-9,600	Residential 9,600 sq. ft.	Single Family Res-Combo
04 120653 RK	R-9,600	Residential 9,600 sq. ft.	Single Family Res-Combo
04 120652 RK	R-9,600	Residential 9,600 sq. ft.	Single Family Res-Combo
04 121044 RK	R-9,600	Residential 9,600 sq. ft.	Single Family Res-Combo
04 121045 RK	R-9,600	Residential 9,600 sq. ft.	Single Family Res-Combo

Accessory Dwelling Units

Index # - File Name: 1.0022 - Single Family Dwellings Data\_Snohomish County.pdf

04 119081 RK	R-9,600	Residential 9,600 sq. ft.	Single Family Res-Combo
04 119082 RK	R-9,600	Residential 9,600 sq. ft.	Single Family Res-Combo
04 120017 RK	R-9,600	Residential 9,600 sq. ft.	Single Family Res-Combo
04 120022 RK	R-9,600	Residential 9,600 sq. ft.	Single Family Res-Combo
04 120025 RK	R-9,600	Residential 9,600 sq. ft.	Single Family Res-Combo
04 120027 RK	R-9,600	Residential 9,600 sq. ft.	Single Family Res-Combo
04 120029 RK	R-9,600	Residential 9,600 sq. ft.	Single Family Res-Combo
04 120031 RK	R-9,600	Residential 9,600 sq. ft.	Single Family Res-Combo
04 120035 RK	R-9,600	Residential 9,600 sq. ft.	Single Family Res-Combo
04 120038 RK	R-9,600	Residential 9,600 sq. ft.	Single Family Res-Combo
04 114579 RK	R-9,600(PRD)	Residential 9,600 sq. ft.	SFR-Basic
04 114584 RK	R-9,600(PRD)	Residential 9,600 sq. ft.	Single Family Res-Combo
04 113871 RK	R-9,600(PRD)	Residential 9,600 sq. ft.	SFR-Basic
04 114306 RK	R-9,600(PRD)	Residential 9,600 sq. ft.	SFR-Basic
04 114303 RK	R-9,600(PRD)	Residential 9,600 sq. ft.	SFR-Basic
04 114933 RK	R-9,600(PRD)	Residential 9,600 sq. ft.	SFR-Basic
04 116183 RK	R-9,600(PRD)	Residential 9,600 sq. ft.	SFR-Basic
04 118250 RK	R-9,600(PRD)	Residential 9,600 sq. ft.	SFR-Basic
04 118248 RK	R-9,600(PRD)	Residential 9,600 sq. ft.	SFR-Basic
04 120974 RK	R-9,600(PRD)	Residential 9,600 sq. ft.	SFR-Basic
04 120976 RK	R-9,600(PRD)	Residential 9,600 sq. ft.	SFR-Basic
04 120977 RK	R-9,600(PRD)	Residential 9,600 sq. ft.	SFR-Basic
04 120978 RK	R-9,600(PRD)	Residential 9,600 sq. ft.	SFR-Basic
04 118869 RK	R-9,600(PRD)	Residential 9,600 sq. ft.	SFR-Basic
04 114321 RK	R-5	Rural-5 Acre	Single Family Res-Combo
04 116428 RK	R-9,600(PRD)	Residential 9,600 sq. ft.	SFR-Basic
04 118252 RK	R-9,600(PRD)	Residential 9,600 sq. ft.	SFR-Basic
04 116429 RK	R-9,600(PRD)	Residential 9,600 sq. ft.	SFR-Basic
04 116184 RK	R-9,600(PRD)	Residential 9,600 sq. ft.	SFR-Basic
04 113875 RK	R-9,600(PRD)	Residential 9,600 sq. ft.	SFR-Basic
04 114300 RK	R-9,600(PRD)	Residential 9,600 sq. ft.	SFR-Basic
04 113870 RK	R-9,600(PRD)	Residential 9,600 sq. ft.	SFR-Basic
04 118870 RK	R-9,600(PRD)	Residential 9,600 sq. ft.	SFR-Basic
04 118871 RK	R-9,600(PRD)	Residential 9,600 sq. ft.	SFR-Basic
04 118872 RK	R-9,600(PRD)	Residential 9,600 sq. ft.	SFR-Basic
04 118885 RK	R-9,600(PRD)	Residential 9,600 sq. ft.	SFR-Basic
04 118873 RK	R-9,600(PRD)	Residential 9,600 sq. ft.	SFR-Basic
04 116311 RK	R-9,600(PRD)	Residential 9,600 sq. ft.	SFR-Basic
04 121257 RK	R-9,600(PRD)	Residential 9,600 sq. ft.	SFR-Basic
04 115239 RK	R-9,600(PRD)	Residential 9,600 sq. ft.	SFR-Basic
04 114583 RK	R-9,600(PRD)	Residential 9,600 sq. ft.	Single Family Res-Combo
04 115708 RK	R-9,600(PRD)	Residential 9,600 sq. ft.	SFR-Basic
04 121259 RK	R-9,600(PRD)	Residential 9,600 sq. ft.	SFR-Basic
04 114581 RK	R-9,600(PRD)	Residential 9,600 sq. ft.	SFR-Basic
04 115662 RK	R-9,600(PRD)	Residential 9,600 sq. ft.	SFR-Basic
04 121256 RK	R-9,600(PRD)	Residential 9,600 sq. ft.	SFR-Basic
04 115706 RK	R-9,600(PRD)	Residential 9,600 sq. ft.	SFR-Basic

Accessory Dwelling Units

Index # - File Name: 1.0022 - Single Family Dwellings Data\_Snohomish County.pdf

04 116310 RK	R-9,600(PRD)	Residential 9,600 sq. ft.	SFR-Basic
04 118689 RK	R-9,600(PRD)	Residential 9,600 sq. ft.	SFR-Basic
04 121258 RK	R-9,600(PRD)	Residential 9,600 sq. ft.	SFR-Basic
04 116099 RK	R-9,600(PRD)	Residential 9,600 sq. ft.	SFR-Basic
04 118254 RK	R-9,600(PRD)	Residential 9,600 sq. ft.	SFR-Basic
04 118874 RK	R-9,600(PRD)	Residential 9,600 sq. ft.	SFR-Basic
04 120964 RK	R-9,600(PRD)	Residential 9,600 sq. ft.	SFR-Basic
04 120968 RK	R-9,600(PRD)	Residential 9,600 sq. ft.	SFR-Basic
04 120972 RK	R-9,600(PRD)	Residential 9,600 sq. ft.	SFR-Basic
04 116683 RK	R-9,600(PRD)	Residential 9,600 sq. ft.	SFR-Basic
04 118688 RK	R-9,600(PRD)	Residential 9,600 sq. ft.	SFR-Basic
04 116684 RK	R-9,600(PRD)	Residential 9,600 sq. ft.	SFR-Basic
04 118895 RK	R-9,600(PRD)	Residential 9,600 sq. ft.	SFR-Basic
04 116682 RK	R-9,600(PRD)	Residential 9,600 sq. ft.	SFR-Basic
04 116679 RK	R-9,600(PRD)	Residential 9,600 sq. ft.	SFR-Basic
04 121260 RK	R-9,600(PRD)	Residential 9,600 sq. ft.	SFR-Basic
04 116676 RK	R-9,600(PRD)	Residential 9,600 sq. ft.	SFR-Basic
04 114455 RK	R-5	Rural-5 Acre	SFR-Basic
04 114459 RK	R-5	Rural-5 Acre	SFR-Basic
04 114285 RK	R-9,600(PRD)	Residential 9,600 sq. ft.	SFR-Basic
04 114290 RK	R-9,600(PRD)	Residential 9,600 sq. ft.	SFR-Basic
04 118876 RK	R-9,600(PRD)	Residential 9,600 sq. ft.	SFR-Basic
04 118879 RK	R-9,600(PRD)	Residential 9,600 sq. ft.	SFR-Basic
04 121515 RK	R-9,600(PRD)	Residential 9,600 sq. ft.	SFR-Basic
04 121518 RK	R-9,600(PRD)	Residential 9,600 sq. ft.	SFR-Basic
04 121537 RK	R-9,600	Residential 9,600 sq. ft.	Single Family Res-Combo
04 114525 MH	A-10	Agriculture-10 Acre	Double Wide
04 113896 RK	R-7,200	Residential 7,200 sq. ft.	Single Family Res-Combo
04 114698 RK	R-7,200	Residential 7,200 sq. ft.	SFR-Basic
04 114705 RK	R-7,200	Residential 7,200 sq. ft.	Single Family Res-Combo
04 113894 RK	R-7,200	Residential 7,200 sq. ft.	Single Family Res-Combo
04 114694 RK	R-7,200	Residential 7,200 sq. ft.	SFR-Basic
04 114711 RK	R-7,200	Residential 7,200 sq. ft.	Single Family Res-Combo
04 114837 RK	R-7,200	Residential 7,200 sq. ft.	Single Family Res-Combo
04 114845 RK	R-7,200	Residential 7,200 sq. ft.	Single Family Res-Combo
04 114838 RK	R-7,200	Residential 7,200 sq. ft.	Single Family Res-Combo
04 114841 RK	R-7,200	Residential 7,200 sq. ft.	Single Family Res-Combo
04 114842 RK	R-7,200	Residential 7,200 sq. ft.	Single Family Res-Combo
04 114843 RK	R-7,200	Residential 7,200 sq. ft.	Single Family Res-Combo
04 114839 RK	R-7,200	Residential 7,200 sq. ft.	Single Family Res-Combo
04 114844 RK	R-7,200	Residential 7,200 sq. ft.	Single Family Res-Combo
04 114840 RK	R-7,200	Residential 7,200 sq. ft.	Single Family Res-Combo
04 114704 RK	R-7,200	Residential 7,200 sq. ft.	Single Family Res-Combo
04 113891 RK	R-7,200	Residential 7,200 sq. ft.	Single Family Res-Combo
04 114700 RK	R-7,200	Residential 7,200 sq. ft.	Single Family Res-Combo
04 114810 RK	RD	Rural Diversification	Single Family Res-Combo
04 114815 RK	CITY	City	SFR-Basic

Accessory Dwelling Units

Index # - File Name: 1.0022 - Single Family Dwellings Data\_Snohomish County.pdf

04 114817 RK	CITY	City	SFR-Basic
04 114818 RK	CITY	City	SFR-Basic
04 114819 RK	CITY	City	SFR-Basic
04 114821 RK	CITY	City	SFR-Basic
04 114823 RK	CITY	City	SFR-Basic
04 114828 RK	CITY	City	SFR-Basic
04 114830 RK	CITY	City	SFR-Basic
04 114820 RK	CITY	City	SFR-Basic
04 114816 RK	CITY	City	SFR-Basic
04 114833 RK	CITY	City	SFR-Basic
04 114832 RK	CITY	City	SFR-Basic
04 114831 RK	CITY	City	SFR-Basic
04 114829 RK	CITY	City	SFR-Basic
04 114826 RK	CITY	City	SFR-Basic
04 114824 RK	CITY	City	SFR-Basic
04 114822 RK	CITY	City	SFR-Basic
04 114293 RK	R-9,600(PRD)	Residential 9,600 sq. ft.	SFR-Basic
04 114929 RK	R-9,600(PRD)	Residential 9,600 sq. ft.	SFR-Basic
04 114279 RK	R-9,600(PRD)	Residential 9,600 sq. ft.	SFR-Basic
04 116182 RK	R-9,600(PRD)	Residential 9,600 sq. ft.	SFR-Basic
04 116424 RK	R-9,600(PRD)	Residential 9,600 sq. ft.	SFR-Basic
04 114295 RK	R-9,600(PRD)	Residential 9,600 sq. ft.	SFR-Basic
04 114931 RK	R-9,600(PRD)	Residential 9,600 sq. ft.	SFR-Basic
04 116423 RK	R-9,600(PRD)	Residential 9,600 sq. ft.	SFR-Basic
04 114932 RK	R-9,600(PRD)	Residential 9,600 sq. ft.	SFR-Basic
04 118311 RK	R-9,600(PRD)	Residential 9,600 sq. ft.	SFR-Basic
04 118315 RK	R-9,600(PRD)	Residential 9,600 sq. ft.	SFR-Basic
04 118316 RK	R-9,600(PRD)	Residential 9,600 sq. ft.	SFR-Basic
04 115140 RK	R-7,200	Residential 7,200 sq. ft.	SFR-Basic
04 115847 RK	R-7,200	Residential 7,200 sq. ft.	SFR-Basic
04 116634 RK	R-7,200	Residential 7,200 sq. ft.	SFR-Basic
04 115855 RK	R-7,200	Residential 7,200 sq. ft.	SFR-Basic
04 115851 RK	R-7,200	Residential 7,200 sq. ft.	SFR-Basic
04 114769 RK	R-7,200	Residential 7,200 sq. ft.	SFR-Basic
04 114797 RK	R-7,200	Residential 7,200 sq. ft.	SFR-Basic
04 116637 RK	R-7,200	Residential 7,200 sq. ft.	SFR-Basic
04 115135 RK	R-7,200	Residential 7,200 sq. ft.	SFR-Basic
04 116638 RK	R-7,200	Residential 7,200 sq. ft.	SFR-Basic
04 114801 RK	R-7,200	Residential 7,200 sq. ft.	SFR-Basic
04 114798 RK	R-7,200	Residential 7,200 sq. ft.	SFR-Basic
04 114768 RK	R-7,200	Residential 7,200 sq. ft.	SFR-Basic
04 114802 RK	R-7,200	Residential 7,200 sq. ft.	SFR-Basic
04 117953 RK	R-7,200	Residential 7,200 sq. ft.	SFR-Basic
04 116636 RK	R-7,200	Residential 7,200 sq. ft.	SFR-Basic
04 117954 RK	R-7,200	Residential 7,200 sq. ft.	SFR-Basic
04 114799 RK	R-7,200	Residential 7,200 sq. ft.	SFR-Basic
04 114804 RK	R-7,200	Residential 7,200 sq. ft.	SFR-Basic

Accessory Dwelling Units

Index # - File Name: 1.0022 - Single Family Dwellings Data\_Snohomish County.pdf

04 116491 RK	R-7,200	Residential 7,200 sq. ft.	SFR-Basic
04 116498 RK	R-7,200	Residential 7,200 sq. ft.	SFR-Basic
04 115298 RK	R-7,200	Residential 7,200 sq. ft.	SFR-Basic
04 116497 RK	R-7,200	Residential 7,200 sq. ft.	SFR-Basic
04 116500 RK	R-7,200	Residential 7,200 sq. ft.	SFR-Basic
04 116496 RK	R-7,200	Residential 7,200 sq. ft.	SFR-Basic
04 117069 RK	R-7,200	Residential 7,200 sq. ft.	SFR-Basic
04 116504 RK	R-7,200	Residential 7,200 sq. ft.	SFR-Basic
04 116507 RK	R-7,200	Residential 7,200 sq. ft.	SFR-Basic
04 116510 RK	R-7,200	Residential 7,200 sq. ft.	SFR-Basic
04 115296 RK	R-7,200	Residential 7,200 sq. ft.	SFR-Basic
04 118546 RK	PRD-9,600	Residential 9,600 sq. ft.	SFR-Basic
04 119740 RK	PRD-9,600	Residential 9,600 sq. ft.	SFR-Basic
04 119075 RK	PRD-9,600	Residential 9,600 sq. ft.	SFR-Basic
04 113853 RK	R-5	Rural-5 Acre	SFR-Basic
04 115246 RK	R-5	Rural-5 Acre	Single Family Res-Combo
04 115188 RK	R-8,400	Residential 8,400 sq. ft.	SFR-Basic
04 120064 RK	PRD-9,600	Residential 9,600 sq. ft.	SFR-Basic
04 121272 RK	PRD-9,600	Residential 9,600 sq. ft.	SFR-Basic
04 121101 RK	PRD-9,600	Residential 9,600 sq. ft.	SFR-Basic
04 121306 RK	PRD-9,600	Residential 9,600 sq. ft.	SFR-Basic
04 118549 RK	PRD-9,600	Residential 9,600 sq. ft.	SFR-Basic
04 115410 RK	PRD-9,600	Residential 9,600 sq. ft.	Single Family Res-Combo
04 115406 RK	PRD-9,600	Residential 9,600 sq. ft.	Single Family Res-Combo
04 116530 RK	PRD-9,600	Residential 9,600 sq. ft.	Single Family Res-Combo
04 116149 RK	PRD-9,600	Residential 9,600 sq. ft.	Single Family Res-Combo
04 115389 RK	PRD-9,600	Residential 9,600 sq. ft.	SFR-Basic
04 117917 RK	PRD-9,600	Residential 9,600 sq. ft.	Single Family Res-Combo
04 119262 RK	PRD-9,600	Residential 9,600 sq. ft.	Single Family Res-Combo
04 115407 RK	PRD-9,600	Residential 9,600 sq. ft.	Single Family Res-Combo
04 119076 RK	PRD-9,600	Residential 9,600 sq. ft.	SFR-Basic
04 115408 RK	PRD-9,600	Residential 9,600 sq. ft.	Single Family Res-Combo
04 121379 RK	PRD-9,600	Residential 9,600 sq. ft.	SFR-Basic
04 121378 RK	PRD-9,600	Residential 9,600 sq. ft.	SFR-Basic
04 120641 RK	PRD-9,600	Residential 9,600 sq. ft.	Single Family Res-Combo
04 118091 RK	PRD-9,600	Residential 9,600 sq. ft.	Single Family Res-Combo
04 117919 RK	PRD-9,600	Residential 9,600 sq. ft.	Single Family Res-Combo
04 117918 RK	PRD-9,600	Residential 9,600 sq. ft.	Single Family Res-Combo
04 116528 RK	PRD-9,600	Residential 9,600 sq. ft.	Single Family Res-Combo
04 115391 RK	PRD-9,600	Residential 9,600 sq. ft.	SFR-Basic
04 116150 RK	PRD-9,600	Residential 9,600 sq. ft.	Single Family Res-Combo
04 121377 RK	PRD-9,600	Residential 9,600 sq. ft.	SFR-Basic
04 116010 RK	PRD-9,600	Residential 9,600 sq. ft.	SFR-Basic
04 115954 RK	PRD-9,600	Residential 9,600 sq. ft.	SFR-Basic
04 120224 RK	PRD-9,600	Residential 9,600 sq. ft.	SFR-Basic
04 115941 RK	PRD-9,600	Residential 9,600 sq. ft.	SFR-Basic
04 115955 RK	PRD-9,600	Residential 9,600 sq. ft.	SFR-Basic



Accessory Dwelling Units

Index # - File Name: 1.0022 - Single Family Dwellings Data\_Snohomish County.pdf

04 115947 RK	PRD-9,600	Residential 9,600 sq. ft.	SFR-Basic
04 115935 RK	PRD-9,600	Residential 9,600 sq. ft.	SFR-Basic
04 120848 RK	PRD-9,600	Residential 9,600 sq. ft.	SFR-Basic
04 117134 RK	PRD-9,600	Residential 9,600 sq. ft.	SFR-Basic
04 117135 RK	PRD-9,600	Residential 9,600 sq. ft.	SFR-Basic
04 121091 RK	PRD-9,600	Residential 9,600 sq. ft.	SFR-Basic
04 120671 RK	PRD-9,600	Residential 9,600 sq. ft.	SFR-Basic
04 115950 RK	PRD-9,600	Residential 9,600 sq. ft.	SFR-Basic
04 115945 RK	PRD-9,600	Residential 9,600 sq. ft.	SFR-Basic
04 119094 RK	PRD-9,600	Residential 9,600 sq. ft.	SFR-Basic
04 115953 RK	PRD-9,600	Residential 9,600 sq. ft.	SFR-Basic
04 117854 RK	PRD-9,600	Residential 9,600 sq. ft.	SFR-Basic
04 116894 RK	R-9,600	Residential 9,600 sq. ft.	Single Family Res-Combo
04 116897 RK	R-9,600	Residential 9,600 sq. ft.	Single Family Res-Combo
04 115839 RK	R-7,200	Residential 7,200 sq. ft.	SFR-Basic
04 115842 RK	R-7,200	Residential 7,200 sq. ft.	SFR-Basic
04 117195 RK	R-7,200	Residential 7,200 sq. ft.	SFR-Basic
04 115843 RK	R-7,200	Residential 7,200 sq. ft.	SFR-Basic
04 115844 RK	R-7,200	Residential 7,200 sq. ft.	SFR-Basic
04 117296 RK	R-7,200	Residential 7,200 sq. ft.	SFR-Basic
04 117290 RK	R-7,200	Residential 7,200 sq. ft.	SFR-Basic
04 116382 RK	R-7,200	Residential 7,200 sq. ft.	SFR-Basic
04 117292 RK	R-7,200	Residential 7,200 sq. ft.	SFR-Basic
04 117297 RK	R-7,200	Residential 7,200 sq. ft.	SFR-Basic
04 116379 RK	R-7,200	Residential 7,200 sq. ft.	SFR-Basic
04 117298 RK	R-7,200	Residential 7,200 sq. ft.	SFR-Basic
04 115302 RK	R-7,200	Residential 7,200 sq. ft.	SFR-Basic
04 117077 RK	R-7,200	Residential 7,200 sq. ft.	SFR-Basic
04 117078 RK	R-7,200	Residential 7,200 sq. ft.	SFR-Basic
04 117073 RK	R-7,200	Residential 7,200 sq. ft.	SFR-Basic
04 117071 RK	R-7,200	Residential 7,200 sq. ft.	SFR-Basic
04 117080 RK	R-7,200	Residential 7,200 sq. ft.	SFR-Basic
04 117081 RK	R-7,200	Residential 7,200 sq. ft.	SFR-Basic
04 117072 RK	R-7,200	Residential 7,200 sq. ft.	SFR-Basic
04 117082 RK	R-7,200	Residential 7,200 sq. ft.	SFR-Basic
04 117084 RK	R-7,200	Residential 7,200 sq. ft.	SFR-Basic
04 117075 RK	R-7,200	Residential 7,200 sq. ft.	SFR-Basic
04 117035 RK	PRD-7,200	Residential 7,200 sq. ft.	SFR-Basic
04 117040 RK	PRD-7,200	Residential 7,200 sq. ft.	SFR-Basic
04 117036 RK	PRD-7,200	Residential 7,200 sq. ft.	SFR-Basic
04 117043 RK	PRD-7,200	Residential 7,200 sq. ft.	Single Family Res-Combo
04 117042 RK	PRD-7,200	Residential 7,200 sq. ft.	SFR-Basic
04 117037 RK	PRD-7,200	Residential 7,200 sq. ft.	SFR-Basic
04 118962 RK	CITY	City	Single Family Res-Combo
04 120266 RK	CITY	City	Single Family Res-Combo
04 120201 RK	CITY	City	Single Family Res-Combo
04 120203 RK	CITY	City	Single Family Res-Combo

Accessory Dwelling Units

Index # - File Name: 1.0022 - Single Family Dwellings Data\_Snohomish County.pdf

04 120261 RK	CITY	City	Single Family Res-Combo
04 120262 RK	CITY	City	Single Family Res-Combo
04 120259 RK	CITY	City	Single Family Res-Combo
04 120202 RK	CITY	City	Single Family Res-Combo
04 120204 RK	CITY	City	Single Family Res-Combo
04 119322 RK	CITY	City	Single Family Res-Combo
04 119318 RK	CITY	City	Single Family Res-Combo
04 119323 RK	CITY	City	Single Family Res-Combo
04 119320 RK	CITY	City	Single Family Res-Combo
04 118936 RK	CITY	City	Single Family Res-Combo
04 118937 RK	CITY	City	Single Family Res-Combo
04 118939 RK	CITY	City	Single Family Res-Combo
04 118942 RK	CITY	City	Single Family Res-Combo
04 118940 RK	CITY	City	Single Family Res-Combo
04 120264 RK	CITY	City	Single Family Res-Combo
04 120260 RK	CITY	City	Single Family Res-Combo
04 120258 RK	CITY	City	Single Family Res-Combo
04 120661 RK	CITY	City	Single Family Res-Combo
04 120943 RK	CITY	City	Single Family Res-Combo
04 120944 RK	CITY	City	Single Family Res-Combo
04 120205 RK	CITY	City	Single Family Res-Combo
04 121037 RK	CITY	City	Single Family Res-Combo
04 115951 RK	PRD-9,600	Residential 9,600 sq. ft.	SFR-Basic
04 115962 RK	PRD-9,600	Residential 9,600 sq. ft.	SFR-Basic
04 120206 RK	CITY	City	Single Family Res-Combo
04 119260 RK	PRD-9,600	Residential 9,600 sq. ft.	Single Family Res-Combo
04 120941 RK	CITY	City	Single Family Res-Combo
04 120942 RK	CITY	City	Single Family Res-Combo
04 116109 MH	R-5	Rural-5 Acre	Double Wide
04 115964 RK	R-5	Rural-5 Acre	Single Family Res-Combo
04 117141 RK	F	Forestry	Single Family Res-Combo
04 119792 RK	CITY	City	SFR-Basic
04 118958 RK	CITY	City	SFR-Basic
04 117417 RK	CITY	City	SFR-Basic
04 117116 RK	CITY	City	SFR-Basic
04 119149 RK	CITY	City	SFR-Basic
04 116658 RK	CITY	City	SFR-Basic
04 116653 RK	CITY	City	SFR-Basic
04 119143 RK	CITY	City	Single Family Res-Combo
04 116773 RK	CITY	City	SFR-Basic
04 116775 RK	CITY	City	SFR-Basic
04 117418 RK	CITY	City	SFR-Basic
04 117419 RK	CITY	City	SFR-Basic
04 119790 RK	CITY	City	SFR-Basic
04 119789 RK	CITY	City	SFR-Basic
04 119147 RK	CITY	City	SFR-Basic
04 118513 RK	CITY	City	SFR-Basic

Accessory Dwelling Units

Index # - File Name: 1.0022 - Single Family Dwellings Data\_Snohomish County.pdf

04 118515 RK	CITY	City	SFR-Basic
04 119150 RK	CITY	City	SFR-Basic
04 117255 RK	R-5	Rural-5 Acre	Single Family Res-Combo
04 117262 RK	R-5	Rural-5 Acre	Single Family Res-Combo
04 118249 RK	R-5	Rural-5 Acre	Single Family Res-Combo
04 118317 RK	R-5	Rural-5 Acre	Single Family Res-Combo
04 119522 RK	R-5	Rural-5 Acre	Single Family Res-Combo
04 118072 RK	R-5	Rural-5 Acre	Single Family Res-Combo
04 117113 RK	CITY	City	SFR-Basic
04 119518 RK	R-5	Rural-5 Acre	Single Family Res-Combo
04 118253 RK	R-5	Rural-5 Acre	Single Family Res-Combo
04 118310 RK	R-5	Rural-5 Acre	Single Family Res-Combo
04 116272 RK	R-5	Rural-5 Acre	SFR-Basic
04 115392 RK	LDMR	Low Density Multiple Reside Duplex-Basic	
04 115377 RK	LDMR	Low Density Multiple Reside Duplex-Basic	
04 117994 RK	R-5	Rural-5 Acre	Single Family Res-Combo
04 116624 RK	R-5	Rural-5 Acre	Single Family Res-Combo
04 116882 RK	R-8,400	Residential 8,400 sq. ft.	Single Family Res-Combo
04 116883 RK	R-8,400	Residential 8,400 sq. ft.	Single Family Res-Combo
04 116886 RK	R-8,400	Residential 8,400 sq. ft.	Single Family Res-Combo
04 116892 RK	R-8,400	Residential 8,400 sq. ft.	Single Family Res-Combo
04 116884 RK	R-8,400	Residential 8,400 sq. ft.	Single Family Res-Combo
04 116885 RK	R-8,400	Residential 8,400 sq. ft.	Single Family Res-Combo
04 116888 RK	R-8,400	Residential 8,400 sq. ft.	Single Family Res-Combo
04 116889 RK	R-8,400	Residential 8,400 sq. ft.	Single Family Res-Combo
04 116891 RK	R-8,400	Residential 8,400 sq. ft.	Single Family Res-Combo
03 109925 RK	R-5	Rural-5 Acre	Single Family Res-Combo
04 119229 RK	R-5	Rural-5 Acre	Single Family Res-Combo
04 116430 RK	R-5	Rural-5 Acre	Single Family Res-Combo
04 117473 RK	R-7,200	Residential 7,200 sq. ft.	Single Family Res-Combo
04 118792 RK	R-9,600	Residential 9,600 sq. ft.	SFR-Basic
04 119038 RK	R-9,600	Residential 9,600 sq. ft.	SFR-Basic
04 119585 RK	R-9,600	Residential 9,600 sq. ft.	SFR-Basic
04 119106 RK	R-9,600	Residential 9,600 sq. ft.	SFR-Basic
04 119107 RK	R-9,600	Residential 9,600 sq. ft.	SFR-Basic
04 119110 RK	R-9,600	Residential 9,600 sq. ft.	SFR-Basic
04 119111 RK	R-9,600	Residential 9,600 sq. ft.	SFR-Basic
04 119112 RK	R-9,600	Residential 9,600 sq. ft.	SFR-Basic
04 119039 RK	R-9,600	Residential 9,600 sq. ft.	SFR-Basic
04 119581 RK	R-9,600	Residential 9,600 sq. ft.	SFR-Basic
04 119041 RK	R-9,600	Residential 9,600 sq. ft.	SFR-Basic
04 120948 RK	PRD-7,200	Residential 7,200 sq. ft.	SFR-Basic
04 120947 RK	PRD-7,200	Residential 7,200 sq. ft.	SFR-Basic
04 120537 RK	PRD-7,200	Residential 7,200 sq. ft.	SFR-Basic
04 120538 RK	PRD-7,200	Residential 7,200 sq. ft.	SFR-Basic
04 120539 RK	PRD-7,200	Residential 7,200 sq. ft.	SFR-Basic
04 120540 RK	PRD-7,200	Residential 7,200 sq. ft.	SFR-Basic

Accessory Dwelling Units

Index # - File Name: 1.0022 - Single Family Dwellings Data\_Snohomish County.pdf

04 120541 RK	PRD-7,200	Residential 7,200 sq. ft.	SFR-Basic
04 120542 RK	PRD-7,200	Residential 7,200 sq. ft.	SFR-Basic
04 120690 RK	R-9,600	Residential 9,600 sq. ft.	Single Family Res-Combo
04 118789 RK	R-9,600	Residential 9,600 sq. ft.	SFR-Basic
04 121373 RK	PRD-7,200	Residential 7,200 sq. ft.	SFR-Basic
04 121375 RK	PRD-7,200	Residential 7,200 sq. ft.	SFR-Basic
04 118498 RK	RRT-10	Rural Resource Transition-10	SFR-Basic
04 117547 RK	R-5	Rural-5 Acre	Single Family Res-Combo
04 118534 RK	PRD-7,200	Residential 7,200 sq. ft.	SFR-Basic
04 118532 RK	PRD-7,200	Residential 7,200 sq. ft.	SFR-Basic
04 118533 RK	PRD-7,200	Residential 7,200 sq. ft.	SFR-Basic
04 120669 RK	PRD-7,200	Residential 7,200 sq. ft.	SFR-Basic
04 120695 RK	PRD-7,200	Residential 7,200 sq. ft.	SFR-Basic
04 120670 RK	PRD-7,200	Residential 7,200 sq. ft.	SFR-Basic
04 119173 RK	PRD-7,200	Residential 7,200 sq. ft.	SFR-Basic
04 119174 RK	PRD-7,200	Residential 7,200 sq. ft.	SFR-Basic
04 119175 RK	PRD-7,200	Residential 7,200 sq. ft.	SFR-Basic
04 119176 RK	PRD-7,200	Residential 7,200 sq. ft.	SFR-Basic
04 119177 RK	PRD-7,200	Residential 7,200 sq. ft.	SFR-Basic
04 120297 RK	PRD-7,200	Residential 7,200 sq. ft.	SFR-Basic
04 120299 RK	PRD-7,200	Residential 7,200 sq. ft.	SFR-Basic
04 120300 RK	PRD-7,200	Residential 7,200 sq. ft.	SFR-Basic
04 120301 RK	PRD-7,200	Residential 7,200 sq. ft.	SFR-Basic
04 120302 RK	PRD-7,200	Residential 7,200 sq. ft.	SFR-Basic
04 120303 RK	PRD-7,200	Residential 7,200 sq. ft.	SFR-Basic
04 119178 RK	PRD-7,200	Residential 7,200 sq. ft.	SFR-Basic
04 121070 RK	PRD-7,200	Residential 7,200 sq. ft.	SFR-Basic
04 120697 RK	PRD-7,200	Residential 7,200 sq. ft.	SFR-Basic
04 120692 RK	PRD-7,200	Residential 7,200 sq. ft.	SFR-Basic
04 121071 RK	PRD-7,200	Residential 7,200 sq. ft.	SFR-Basic
04 121072 RK	PRD-7,200	Residential 7,200 sq. ft.	SFR-Basic
04 119179 RK	PRD-7,200	Residential 7,200 sq. ft.	SFR-Basic
04 119166 RK	PRD-7,200	Residential 7,200 sq. ft.	SFR-Basic
04 120694 RK	PRD-7,200	Residential 7,200 sq. ft.	SFR-Basic
04 119167 RK	PRD-7,200	Residential 7,200 sq. ft.	SFR-Basic
04 119168 RK	PRD-7,200	Residential 7,200 sq. ft.	SFR-Basic
04 119170 RK	PRD-7,200	Residential 7,200 sq. ft.	SFR-Basic
04 119171 RK	PRD-7,200	Residential 7,200 sq. ft.	SFR-Basic
04 118911 RK	PRD-7,200	Residential 7,200 sq. ft.	SFR-Basic
04 118918 RK	PRD-7,200	Residential 7,200 sq. ft.	SFR-Basic
04 119172 RK	PRD-7,200	Residential 7,200 sq. ft.	SFR-Basic
04 118637 RK	PRD-7,200	Residential 7,200 sq. ft.	SFR-Basic
04 118643 RK	PRD-7,200	Residential 7,200 sq. ft.	SFR-Basic
04 119032 RK	PRD-7,200	Residential 7,200 sq. ft.	Duplex-Combo
04 118646 RK	PRD-7,200	Residential 7,200 sq. ft.	SFR-Basic
04 121073 RK	PRD-7,200	Residential 7,200 sq. ft.	SFR-Basic
04 117611 RK	R-7,200	Residential 7,200 sq. ft.	SFR-Basic

Accessory Dwelling Units

Index # - File Name: 1.0022 - Single Family Dwellings Data\_Snohomish County.pdf

04 117614 RK	R-7,200	Residential 7,200 sq. ft.	SFR-Basic
04 120861 RK	R-7,200	Residential 7,200 sq. ft.	SFR-Basic
04 119399 RK	R-7,200	Residential 7,200 sq. ft.	Single Family Res-Combo
04 119579 RK	R-7,200	Residential 7,200 sq. ft.	SFR-Basic
04 120836 RK	CITY	City	SFR-Basic
04 120564 RK	CITY	City	SFR-Basic
04 117928 RK	CITY	City	SFR-Basic
04 117929 RK	CITY	City	SFR-Basic
04 120171 RK	CITY	City	SFR-Basic
04 120870 RK	CITY	City	SFR-Basic
04 120172 RK	CITY	City	SFR-Basic
04 120173 RK	CITY	City	SFR-Basic
04 117930 RK	CITY	City	SFR-Basic
04 118464 RK	CITY	City	SFR-Basic
04 119980 RK	CITY	City	SFR-Basic
04 120559 RK	CITY	City	SFR-Basic
04 120832 RK	CITY	City	SFR-Basic
04 121231 RK	CITY	City	SFR-Basic
04 120562 RK	CITY	City	SFR-Basic
04 119741 RK	R-5	Rural-5 Acre	Single Family Res-Combo
04 115305 RK	R-5	Rural-5 Acre	Single Family Res-Combo
04 118082 RK	R-5	Rural-5 Acre	Single Family Res-Combo
04 119070 RK	PRD-7,200	Residential 7,200 sq. ft.	Single Family Res-Combo
04 119062 RK	PRD-7,200	Residential 7,200 sq. ft.	SFR-Basic
04 119066 RK	PRD-7,200	Residential 7,200 sq. ft.	SFR-Basic
04 119069 RK	PRD-7,200	Residential 7,200 sq. ft.	Single Family Res-Combo
04 119067 RK	PRD-7,200	Residential 7,200 sq. ft.	Single Family Res-Combo
04 119063 RK	PRD-7,200	Residential 7,200 sq. ft.	SFR-Basic
04 117984 RK	R-5	Rural-5 Acre	Single Family Res-Combo
04 118476 RK	R-5	Rural-5 Acre	Single Family Res-Combo
04 119995 RK	R-7,200	Residential 7,200 sq. ft.	Single Family Res-Combo
04 119998 RK	R-7,200	Residential 7,200 sq. ft.	Single Family Res-Combo
04 121444 RK	CITY	City	SFR-Basic
04 119981 RK	CITY	City	SFR-Basic
04 118093 RK	CITY	City	Single Family Res-Combo
04 118944 RK	R-7,200	Residential 7,200 sq. ft.	Single Family Res-Combo
04 120984 RK	R-7,200	Residential 7,200 sq. ft.	Single Family Res-Combo
04 120981 RK	R-7,200	Residential 7,200 sq. ft.	Single Family Res-Combo
04 119405 RK	R-7,200	Residential 7,200 sq. ft.	Single Family Res-Combo
04 118348 RK	R-5	Rural-5 Acre	Single Family Res-Combo
04 120575 RK	R-5	Rural-5 Acre	SFR-Basic
04 118494 RK	R-12,500	Residential 12,500 sq. ft.	SFR-Basic
04 118798 RK	CITY	City	Single Family Res-Combo
04 118860 RK	R-5	Rural-5 Acre	SFR-Basic
04 121277 RK	R-5	Rural-5 Acre	SFR-Basic
04 120687 RK	R-5	Rural-5 Acre	SFR-Basic
04 119782 RK	R-7,200	Residential 7,200 sq. ft.	SFR-Basic

Accessory Dwelling Units

Index # - File Name: 1.0022 - Single Family Dwellings Data\_Snohomish County.pdf

04 119783 RK	R-7,200	Residential 7,200 sq. ft.	SFR-Basic
04 119784 RK	R-7,200	Residential 7,200 sq. ft.	SFR-Basic
04 119786 RK	R-7,200	Residential 7,200 sq. ft.	SFR-Basic
04 119787 RK	R-7,200	Residential 7,200 sq. ft.	SFR-Basic
04 121019 RK	PRD-9,600	Residential 9,600 sq. ft.	SFR-Basic
04 121020 RK	PRD-9,600	Residential 9,600 sq. ft.	SFR-Basic
04 121022 RK	PRD-9,600	Residential 9,600 sq. ft.	SFR-Basic
04 121024 RK	PRD-9,600	Residential 9,600 sq. ft.	SFR-Basic
04 119151 RK	F	Forestry	Single Family Res-Combo
04 119781 RK	R-7,200	Residential 7,200 sq. ft.	SFR-Basic
04 121017 RK	PRD-9,600	Residential 9,600 sq. ft.	SFR-Basic
04 121018 RK	PRD-9,600	Residential 9,600 sq. ft.	SFR-Basic
04 120050 RK	CITY	City	Single Family Res-Combo
04 117926 RK	CITY	City	Single Family Res-Combo
04 116846 RK	CITY	City	Single Family Res-Combo
04 117923 RK	CITY	City	Single Family Res-Combo
04 120054 RK	CITY	City	Single Family Res-Combo
04 120338 RK	CITY	City	SFR-Basic
04 120334 RK	CITY	City	SFR-Basic
04 120341 RK	CITY	City	SFR-Basic
04 120343 RK	CITY	City	SFR-Basic
04 120333 RK	CITY	City	SFR-Basic
04 120336 RK	CITY	City	SFR-Basic
04 120337 RK	CITY	City	SFR-Basic
04 120339 RK	CITY	City	SFR-Basic
04 120342 RK	CITY	City	SFR-Basic
04 120451 RK	R-7,200	Residential 7,200 sq. ft.	SFR-Basic
04 120448 RK	R-7,200	Residential 7,200 sq. ft.	SFR-Basic
04 120452 RK	R-7,200	Residential 7,200 sq. ft.	SFR-Basic
04 121013 RK	R-7,200	Residential 7,200 sq. ft.	SFR-Basic
04 120457 RK	R-7,200	Residential 7,200 sq. ft.	SFR-Basic
04 121014 RK	R-7,200	Residential 7,200 sq. ft.	SFR-Basic
04 113705 RK	R-7,200	Residential 7,200 sq. ft.	Single Family Res-Combo
04 120454 RK	R-7,200	Residential 7,200 sq. ft.	SFR-Basic
04 120455 RK	R-7,200	Residential 7,200 sq. ft.	SFR-Basic
04 120456 RK	R-7,200	Residential 7,200 sq. ft.	SFR-Basic
04 121012 RK	R-7,200	Residential 7,200 sq. ft.	SFR-Basic
04 120453 RK	R-7,200	Residential 7,200 sq. ft.	SFR-Basic
04 120516 RK	R-7,200	Residential 7,200 sq. ft.	Single Family Res-Combo
04 120679 RK	R-7,200	Residential 7,200 sq. ft.	SFR-Basic
04 118079 RK	R-7,200	Residential 7,200 sq. ft.	SFR-Basic
04 120988 RK	R-7,200	Residential 7,200 sq. ft.	SFR-Basic
04 120778 RK	R-7,200	Residential 7,200 sq. ft.	SFR-Basic
04 120991 RK	R-7,200	Residential 7,200 sq. ft.	SFR-Basic
04 120992 RK	R-7,200	Residential 7,200 sq. ft.	SFR-Basic
04 120677 RK	R-7,200	Residential 7,200 sq. ft.	SFR-Basic
04 120994 RK	R-7,200	Residential 7,200 sq. ft.	SFR-Basic

Accessory Dwelling Units

Index # - File Name: 1.0022 - Single Family Dwellings Data\_Snohomish County.pdf

04 120610 RK	R-7,200	Residential 7,200 sq. ft.	SFR-Basic
04 120779 RK	R-7,200	Residential 7,200 sq. ft.	SFR-Basic
04 121023 RK	R-7,200	Residential 7,200 sq. ft.	SFR-Basic
04 120513 RK	R-9,600	Residential 9,600 sq. ft.	SFR-Basic
04 120515 RK	R-9,600	Residential 9,600 sq. ft.	SFR-Basic
04 120519 RK	R-9,600	Residential 9,600 sq. ft.	SFR-Basic
04 120520 RK	R-9,600	Residential 9,600 sq. ft.	SFR-Basic
04 120531 RK	R-9,600	Residential 9,600 sq. ft.	SFR-Basic
04 120987 RK	R-7,200	Residential 7,200 sq. ft.	SFR-Basic
04 120777 RK	R-7,200	Residential 7,200 sq. ft.	SFR-Basic
04 120762 RK	R-5	Rural-5 Acre	Single Family Res-Combo
04 120664 RK	CITY	City	SFR-Basic
04 120665 RK	CITY	City	SFR-Basic
04 120666 RK	CITY	City	SFR-Basic
04 120667 RK	CITY	City	SFR-Basic
04 116618 RK	SA-1	Suburban Agriculture-1 Acre	Single Family Res-Combo
03 111069 RK	R-5	Rural-5 Acre	Single Family Res-Combo
04 112559 RK	LDMR	Low Density Multiple Reside	Single Family Res-Combo
03 107337 RK	R-5	Rural-5 Acre	Single Family Res-Combo
04 110364 RK	R-5	Rural-5 Acre	Single Family Res-Combo
04 110943 RK	R-5	Rural-5 Acre	Single Family Res-Combo
04 112513 RK	R-5	Rural-5 Acre	Single Family Res-Combo
04 109370 RK	R-5	Rural-5 Acre	Single Family Res-Combo
03 109340 RK	R-5	Rural-5 Acre	Single Family Res-Combo
04 113491 RK	R-5	Rural-5 Acre	Single Family Res-Combo
04 116100 RK	R-5	Rural-5 Acre	Single Family Res-Combo
04 118875 RK	R-5	Rural-5 Acre	Single Family Res-Combo
04 118728 RK	R-5	Rural-5 Acre	Single Family Res-Combo
04 115039 RK	R-5	Rural-5 Acre	Single Family Res-Combo
03 102470 RK	R-5	Rural-5 Acre	Single Family Res-Combo
04 100330 RK	R-5	Rural-5 Acre	Single Family Res-Combo
04 100119 RK	R-5	Rural-5 Acre	SFR-Basic
04 116687 RK	F	Forestry	Single Family Res-Combo
04 116980 RK	RRT-10	Rural Resource Transition-10	SFR-Basic
03 110634 RK	RC	Rural Conservation	Single Family Res-Combo
04 117181 RK	R-5	Rural-5 Acre	Single Family Res-Combo
03 101238 001 00 RK	R-5	Rural-5 Acre	Single Family Res-Combo
04 112048 MH	R-5	Rural-5 Acre	Double Wide
04 108694 RK	R-5	Rural-5 Acre	SFR-Basic
04 111952 RK	RRT-10	Rural Resource Transition-10	Single Family Res-Combo
03 108753 RK	R-5	Rural-5 Acre	Single Family Res-Combo
04 112450 RK	R-5	Rural-5 Acre	Single Family Res-Combo
03 111013 RK	RC	Rural Conservation	SFR-Basic
03 100451 MH	R-5	Rural-5 Acre	Double Wide
04 100293 MH	R-5	Rural-5 Acre	Double Wide
04 114803 RK	R-5	Rural-5 Acre	Accessory Apt Detached-Combo
03 111014 RK	RC	Rural Conservation	SFR-Basic

Accessory Dwelling Units

Index # - File Name: 1.0022 - Single Family Dwellings Data\_Snohomish County.pdf

04 115409 RK	R-5	Rural-5 Acre	Single Family Res-Combo
04 116152 RK	R-5	Rural-5 Acre	Single Family Res-Combo
04 116176 RK	R-5	Rural-5 Acre	Single Family Res-Combo
04 116572 RK	R-5	Rural-5 Acre	Single Family Res-Combo
03 108110 RK	R-5	Rural-5 Acre	Single Family Res-Combo
04 116826 RK	R-5	Rural-5 Acre	Single Family Res-Combo
03 109287 RK	R-8,400	Residential 8,400 sq. ft.	Duplex-Combo
04 100224 RK	R-5	Rural-5 Acre	Single Family Res-Combo
03 109288 RK	R-8,400	Residential 8,400 sq. ft.	Duplex-Combo
04 111079 RK	R-5	Rural-5 Acre	Single Family Res-Combo
04 109897 RK	R-5	Rural-5 Acre	Single Family Res-Combo
04 110483 RK	R-5	Rural-5 Acre	Single Family Res-Combo
04 113001 RK	R-5	Rural-5 Acre	Single Family Res-Combo
04 116304 RK	R-5	Rural-5 Acre	Single Family Res-Combo
01 101363 000 01 RK	R-5	Rural-5 Acre	Single Family Res-Combo
02 100918 000 01 RK	R-5	Rural-5 Acre	Single Family Res-Combo
04 115402 RK	R-9,600	Residential 9,600 sq. ft.	SFR-Basic
04 113764 RK	R-9,600	Residential 9,600 sq. ft.	SFR-Basic
04 113765 RK	R-9,600	Residential 9,600 sq. ft.	SFR-Basic
04 109827 RK	R-9,600	Residential 9,600 sq. ft.	SFR-Basic
04 112781 RK	R-5	Rural-5 Acre	Single Family Res-Combo
04 113141 RK	R-5	Rural-5 Acre	Single Family Res-Combo
04 114552 RK	R-5	Rural-5 Acre	Single Family Res-Combo
04 113394 RK	R-5	Rural-5 Acre	Single Family Res-Combo
04 100139 RK	R-5	Rural-5 Acre	Single Family Res-Combo
03 106387 RK	R-5	Rural-5 Acre	Single Family Res-Combo
04 100136 RK	R-5	Rural-5 Acre	SFR-Basic
04 100382 RK	R-5	Rural-5 Acre	Single Family Res-Combo
04 110977 RK	R-5	Rural-5 Acre	Single Family Res-Combo
04 115170 RK	R-5	Rural-5 Acre	Single Family Res-Combo
04 110980 RK	R-5	Rural-5 Acre	SFR-Basic
04 118098 RK	R-5	Rural-5 Acre	SFR-Basic
04 118099 RK	R-5	Rural-5 Acre	Single Family Res-Combo
04 116484 RK	R-5	Rural-5 Acre	Single Family Res-Combo
04 114012 RK	R-5	Rural-5 Acre	Single Family Res-Combo
04 115308 RK	R-5	Rural-5 Acre	Single Family Res-Combo
04 117556 RK	R-5	Rural-5 Acre	Single Family Res-Combo
04 113068 RK	R-5	Rural-5 Acre	SFR-Basic
04 113077 RK	R-5	Rural-5 Acre	SFR-Basic
03 105505 RK	R-5	Rural-5 Acre	Single Family Res-Combo
04 114479 RK	R-5	Rural-5 Acre	Single Family Res-Combo
04 114483 RK	R-5	Rural-5 Acre	Single Family Res-Combo
04 111933 RK	R-5	Rural-5 Acre	Single Family Res-Combo
04 112076 RK	R-5	Rural-5 Acre	SFR-Basic
01 112450 000 01 RK	R-5	Rural-5 Acre	Single Family Res-Combo
02 108130 RK	R-5	Rural-5 Acre	Single Family Res-Combo
04 109093 RK	R-5	Rural-5 Acre	Single Family Res-Combo



Accessory Dwelling Units

Index # - File Name: 1.0022 - Single Family Dwellings Data\_Snohomish County.pdf

04 112903 RK	R-5	Rural-5 Acre	Single Family Res-Combo
03 111101 RK	R-5	Rural-5 Acre	Single Family Res-Combo
04 117511 MH	MHP	Mobile Home Park	MH Park-Double Wide
04 112612 RK	R-5	Rural-5 Acre	Single Family Res-Combo
04 111224 RK	R-5	Rural-5 Acre	Single Family Res-Combo
04 109820 RK	R-5	Rural-5 Acre	Single Family Res-Combo
04 111520 RK	R-5	Rural-5 Acre	Single Family Res-Combo
04 114088 RK	R-5	Rural-5 Acre	Single Family Res-Combo
04 109218 RK	R-5	Rural-5 Acre	Single Family Res-Combo
04 109194 RK	R-5	Rural-5 Acre	Single Family Res-Combo
04 115659 MH	RD	Rural Diversification	Double Wide
04 113093 MH	RD	Rural Diversification	Triple Wide
03 110934 RK	R-5	Rural-5 Acre	Single Family Res-Combo
03 110308 RK	R-5	Rural-5 Acre	Single Family Res-Combo
04 108835 RK	R-5	Rural-5 Acre	Single Family Res-Combo
04 112748 RK	R-5	Rural-5 Acre	Single Family Res-Combo
04 117005 RK	R-5	Rural-5 Acre	Single Family Res-Combo
04 117000 RK	R-5	Rural-5 Acre	Single Family Res-Combo
02 109254 RK	R-5	Rural-5 Acre	SFR-Basic
02 109253 RK	R-5	Rural-5 Acre	SFR-Basic
02 106437 000 01 RK	R-5	Rural-5 Acre	SFR-Basic
02 106436 000 01 RK	R-5	Rural-5 Acre	SFR-Basic
04 118062 RK	R-5	Rural-5 Acre	Single Family Res-Combo
04 111533 RK	R-5	Rural-5 Acre	SFR-Basic
04 112975 RK	R-5	Rural-5 Acre	SFR-Basic
04 109743 RK	R-5	Rural-5 Acre	Single Family Res-Combo
04 110826 RK	R-5	Rural-5 Acre	Single Family Res-Combo
03 106627 RK	TRIBES	Native American Land	Single Family Res-Combo
02 101552 000 01 RK	R-5	Rural-5 Acre	Single Family Res-Combo
04 119077 RK	R-5	Rural-5 Acre	Single Family Res-Combo
04 108521 RK	R-5	Rural-5 Acre	Single Family Res-Combo
03 109481 RK	R-5	Rural-5 Acre	Single Family Res-Combo
04 113468 RK	R-5	Rural-5 Acre	Single Family Res-Combo
04 118809 RK	R-5	Rural-5 Acre	Single Family Res-Combo
04 119196 RK	R-5	Rural-5 Acre	Single Family Res-Combo
04 109999 RK	R-5	Rural-5 Acre	Single Family Res-Combo
02 105723 RK	PRD-9,600	Residential 9,600 sq. ft.	SFR-Basic
02 105719 RK	PRD-9,600	Residential 9,600 sq. ft.	SFR-Basic
02 105720 RK	PRD-9,600	Residential 9,600 sq. ft.	SFR-Basic
04 114568 RK	A-10	Agriculture-10 Acre	Single Family Res-Combo
02 105722 RK	PRD-9,600	Residential 9,600 sq. ft.	SFR-Basic
02 105721 RK	PRD-9,600	Residential 9,600 sq. ft.	SFR-Basic
04 113817 RK	R-5	Rural-5 Acre	Single Family Res-Combo
04 112051 MH	R-5	Rural-5 Acre	Double Wide
04 112055 MH	R-5	Rural-5 Acre	Double Wide
04 117435 RK	R-5	Rural-5 Acre	Single Family Res-Combo
04 118555 RK	RC	Rural Conservation	Single Family Res-Combo

Accessory Dwelling Units

Index # - File Name: 1.0022 - Single Family Dwellings Data\_Snohomish County.pdf

04 114644 RK	R-5	Rural-5 Acre	Single Family Res-Combo
04 115189 RK	R-5	Rural-5 Acre	Single Family Res-Combo
04 116648 RK	F	Forestry	Single Family Res-Combo
04 112517 RK	R-5	Rural-5 Acre	Single Family Res-Combo
04 112211 RK	R-5	Rural-5 Acre	SFR-Basic
04 113980 RK	F	Forestry	Single Family Res-Combo
03 110016 RK	F	Forestry	Single Family Res-Combo
04 109328 RK	R-5	Rural-5 Acre	Single Family Res-Combo
03 110859 RK	R-5	Rural-5 Acre	SFR-Basic
04 114056 RK	R-5	Rural-5 Acre	SFR-Basic
02 105641 MH	R-5	Rural-5 Acre	Single Wide
04 118571 RK	R-5	Rural-5 Acre	Single Family Res-Combo
04 111395 RK	PRD SA-1	Suburban Agriculture-1 Acre	Single Family Res-Combo
04 113771 RK	PRD SA-1	Suburban Agriculture-1 Acre	SFR-Basic
04 109201 RK	PRD SA-1	Suburban Agriculture-1 Acre	SFR-Basic
04 115055 RK	PRD SA-1	Suburban Agriculture-1 Acre	SFR-Basic
04 109200 RK	PRD SA-1	Suburban Agriculture-1 Acre	SFR-Basic
04 109362 RK	R-5	Rural-5 Acre	Single Family Res-Combo
01 105202 000 01 RK	F	Forestry	Single Family Res-Combo
04 109161 MH	R-5	Rural-5 Acre	Triple Wide
04 108843 RK	R-5	Rural-5 Acre	Single Family Res-Combo
04 116077 MH	RRT-10	Rural Resource Transition-10	Triple Wide
04 115288 RK	R-5	Rural-5 Acre	SFR-Basic
04 109813 RK	F	Forestry	Single Family Res-Combo
03 110855 RK	R-5	Rural-5 Acre	SFR-Basic
04 117300 RK	R-5	Rural-5 Acre	Single Family Res-Combo
04 115335 RK	R-5	Rural-5 Acre	Single Family Res-Combo
04 110149 RK	R-5	Rural-5 Acre	Single Family Res-Combo
04 110914 RK	CITY	City	Single Family Res-Combo
04 110401 RK	R-5	Rural-5 Acre	Single Family Res-Combo
04 113388 RK	R-8,400	Residential 8,400 sq. ft.	Single Family Res-Combo
04 113596 RK	R-5	Rural-5 Acre	Single Family Res-Combo
01 108182 000 01 RK	R-5	Rural-5 Acre	Single Family Res-Combo
03 111026 RK	R-5	Rural-5 Acre	Single Family Res-Combo
03 104038 MH	R-5	Rural-5 Acre	Double Wide
04 112429 RK	R-5	Rural-5 Acre	Single Family Res-Combo
04 112638 RK	R-5	Rural-5 Acre	Single Family Res-Combo
04 100239 RK	R-5	Rural-5 Acre	Single Family Res-Combo
01 100295 000 01 RK	CITY	City	Single Family Res-Combo
04 117115 RK	R-5	Rural-5 Acre	Single Family Res-Combo
04 114766 RK	R-5	Rural-5 Acre	Single Family Res-Combo
03 110298 RK	CITY	City	Duplex-Basic
04 116171 RK	R-5	Rural-5 Acre	Single Family Res-Combo
04 118756 RK	R-5	Rural-5 Acre	Single Family Res-Combo
02 104063 000 01 RK	R-5 : RC	Rural Conservation : Rural-5	Single Family Res-Combo
04 112310 RK	R-5	Rural-5 Acre	Single Family Res-Combo
03 106520 RK	R-5	Rural-5 Acre	Single Family Res-Combo

Accessory Dwelling Units

Index # - File Name: 1.0022 - Single Family Dwellings Data\_Snohomish County.pdf

04 115179 RK	R-5	Rural-5 Acre	Single Family Res-Combo
04 115399 RK	R-5	Rural-5 Acre	Single Family Res-Combo
04 112532 RK	R-9,600	Residential 9,600 sq. ft.	SFR-Basic
04 112525 RK	R-9,600	Residential 9,600 sq. ft.	SFR-Basic
04 110952 RK	R-9,600	Residential 9,600 sq. ft.	SFR-Basic
04 113910 MH	R-5	Rural-5 Acre	Double Wide
04 116873 RK	R-5	Rural-5 Acre	Single Family Res-Combo
04 114046 RK	R-5	Rural-5 Acre	SFR-Basic
04 115090 RK	R-5	Rural-5 Acre	Single Family Res-Combo
04 119270 RK	R-5	Rural-5 Acre	Single Family Res-Combo
04 115307 RK	R-5	Rural-5 Acre	Accessory Apt Detached-Combo
04 112881 MH	A-10	Agriculture-10 Acre	Triple Wide
04 115321 RK	R-5	Rural-5 Acre	Single Family Res-Combo
04 113426 RK	R-5	Rural-5 Acre	Accessory Apt Detached-Combo
02 102324 000 01 RK	R-5	Rural-5 Acre	Single Family Res-Combo
04 113803 RK	A-10	Agriculture-10 Acre	Single Family Res-Combo
04 113899 RK	F	Forestry	Single Family Res-Combo
04 113163 RK	R-5	Rural-5 Acre	Single Family Res-Combo
03 102561 MH	R-5	Rural-5 Acre	Double Wide
04 111307 RK	R-5	Rural-5 Acre	Single Family Res-Combo
04 108956 RK	F	Forestry	Single Family Res-Combo
04 116774 RK	A-10	Agriculture-10 Acre	Single Family Res-Combo
04 115647 RK	SA-1	Suburban Agriculture-1 Acre	Single Family Res-Combo
02 108239 RK	R-9,600	Residential 9,600 sq. ft.	Single Family Res-Combo
04 113533 RK	R-7,200	Residential 7,200 sq. ft.	SFR-Basic
04 113536 RK	R-7,200	Residential 7,200 sq. ft.	SFR-Basic
04 113534 RK	R-7,200	Residential 7,200 sq. ft.	SFR-Basic
04 113532 RK	R-7,200	Residential 7,200 sq. ft.	SFR-Basic
04 100169 RK	R-5	Rural-5 Acre	SFR-Basic
04 100253 RK	R-5	Rural-5 Acre	Single Family Res-Combo
04 100173 RK	R-5	Rural-5 Acre	SFR-Basic
04 114777 RK	R-5	Rural-5 Acre	Single Family Res-Combo
03 108860 RK	R-5	Rural-5 Acre	Single Family Res-Combo
04 113067 RK	R-5	Rural-5 Acre	Single Family Res-Combo
03 109061 RK	R-5	Rural-5 Acre	Single Family Res-Combo
03 110929 RK	R-5	Rural-5 Acre	Single Family Res-Combo
04 116169 RK	R-5	Rural-5 Acre	Single Family Res-Combo
04 109280 RK	R-5	Rural-5 Acre	Single Family Res-Combo
04 110415 RK	R-5	Rural-5 Acre	Single Family Res-Combo
04 115265 RK	R-5	Rural-5 Acre	Single Family Res-Combo
04 117288 RK	MR	Multiple Residential	Accessory Apt Detached-Combo
04 114681 RK			Single Family Res-Combo
03 105383 RK	R-9,600	Residential 9,600 sq. ft.	Accessory Apt Detached-Combo
03 111073 RK	CITY	City	Single Family Res-Combo
04 100342 RK	R-5	Rural-5 Acre	Single Family Res-Combo
04 115416 RK	R-5	Rural-5 Acre	Single Family Res-Combo
04 111009 RK	R-5	Rural-5 Acre	Single Family Res-Combo

Accessory Dwelling Units

Index # - File Name: 1.0022 - Single Family Dwellings Data\_Snohomish County.pdf

04 109211 RK	R-5	Rural-5 Acre	Single Family Res-Combo
04 110360 MH	R-5	Rural-5 Acre	Double Wide
03 108855 RK	R-5	Rural-5 Acre	Single Family Res-Combo
04 116748 RK	R-5	Rural-5 Acre	Single Family Res-Combo
04 112755 RK	R-5	Rural-5 Acre	Single Family Res-Combo
03 109100 RK	R-5	Rural-5 Acre	Single Family Res-Combo
04 113856 MH	R-5	Rural-5 Acre	Triple Wide
03 105109 RK	R-5	Rural-5 Acre	Single Family Res-Combo
03 105108 RK	R-5	Rural-5 Acre	Single Family Res-Combo
03 105107 RK	R-5	Rural-5 Acre	Single Family Res-Combo
03 107370 RK	F	Forestry	Single Family Res-Combo
03 110689 RK	F	Forestry	Single Family Res-Combo
04 112941 MH	PRD-20,000(M	Residential 20,000 sq. ft.	Single Wide
04 110689 RK	F	Forestry	Single Family Res-Combo
03 110141 MH	R-5	Rural-5 Acre	Double Wide
04 108666 RK	R-9,600	Residential 9,600 sq. ft.	Single Family Res-Combo
04 115442 RK	R-9,600	Residential 9,600 sq. ft.	Single Family Res-Combo
04 115974 MH	R-5	Rural-5 Acre	Double Wide
04 110695 RK	WFB	Waterfront Beach	Single Family Res-Combo
04 116306 RK	R-9,600	Residential 9,600 sq. ft.	Single Family Res-Combo
04 100162 RK	R-9,600	Residential 9,600 sq. ft.	Duplex-Basic
04 112388 RK	F	Forestry	Single Family Res-Combo
04 109577 MH	R-5	Rural-5 Acre	Triple Wide
04 114036 RK	R-5	Rural-5 Acre	Single Family Res-Combo
04 115181 RK			Duplex-Combo
04 116751 RK	R-7,200	Residential 7,200 sq. ft.	Single Family Res-Combo
04 120285 RK	R-5	Rural-5 Acre	Single Family Res-Combo
04 113949 RK	WFB	Waterfront Beach	Single Family Res-Combo
03 110045 RK	R-20,000	Residential 20,000 sq. ft.	Single Family Res-Combo
04 117550 MH	R-5	Rural-5 Acre	Double Wide
02 106625 000 01 RK	R-5	Rural-5 Acre	Single Family Res-Combo
04 100282 RK	R-5	Rural-5 Acre	Single Family Res-Combo
03 110142 RK	R-5	Rural-5 Acre	Single Family Res-Combo
04 115353 RK	R-5 : SA-1	Rural-5 Acre : Suburban Agri	Single Family Res-Combo
04 113941 MH	F	Forestry	Double Wide
02 103725 000 01 RK	R-5	Rural-5 Acre	Single Family Res-Combo
04 110231 RK	R-5	Rural-5 Acre	Single Family Res-Combo
04 116868 RK	R-5	Rural-5 Acre	Single Family Res-Combo
04 112495 RK	R-5	Rural-5 Acre	Single Family Res-Combo
04 115787 RK	R-5	Rural-5 Acre	Accessory Apt Detached-Combo
04 112623 MH	R-5	Rural-5 Acre	Triple Wide
04 114771 RK	R-5	Rural-5 Acre	Accessory Apt Detached-Combo
04 111288 RK	R-5	Rural-5 Acre	Single Family Res-Combo
04 115066 MH	R-5	Rural-5 Acre	Double Wide
04 112182 RK	R-5	Rural-5 Acre	Single Family Res-Combo
04 112491 RK	R-5	Rural-5 Acre	Single Family Res-Combo
04 112554 RK	R-5	Rural-5 Acre	Single Family Res-Combo

Accessory Dwelling Units

Index # - File Name: 1.0022 - Single Family Dwellings Data\_Snohomish County.pdf

04 112096 RK	R-5	Rural-5 Acre	Single Family Res-Combo
04 120046 RK	R-5	Rural-5 Acre	Single Family Res-Combo
04 110997 RK	R-5	Rural-5 Acre	Single Family Res-Combo
04 100397 RK	A-10	Agriculture-10 Acre	Duplex-Combo
04 111336 RK	R-8,400	Residential 8,400 sq. ft.	SFR-Basic
04 113465 RK	R-9,600	Residential 9,600 sq. ft.	Accessory Apt Detached-Combo
04 110565 RK	R-5	Rural-5 Acre	Single Family Res-Combo
04 115208 RK	R-9,600	Residential 9,600 sq. ft.	SFR-Basic
04 116288 RK	F	Forestry	Single Family Res-Combo
03 110279 RK	R-7,200	Residential 7,200 sq. ft.	Duplex-Combo
04 110156 RK	R-9,600	Residential 9,600 sq. ft.	Single Family Res-Combo
04 111163 RK	WFB	Waterfront Beach	Single Family Res-Combo
04 115900 RK	R-9,600	Residential 9,600 sq. ft.	Single Family Res-Combo
04 114987 RK	R-8,400	Residential 8,400 sq. ft.	Single Family Res-Combo
04 115206 RK	CITY	City	Single Family Res-Combo
04 115774 MH	R-5	Rural-5 Acre	Double Wide
04 109950 RK	R-7,200	Residential 7,200 sq. ft.	Single Family Res-Combo
04 112486 RK	R-7,200	Residential 7,200 sq. ft.	SFR-Basic
04 110835 RK	R-7,200	Residential 7,200 sq. ft.	Single Family Res-Combo
02 109692 000 01 MH	R-7,200	Residential 7,200 sq. ft.	Triple Wide
04 114598 RK	R-7,200	Residential 7,200 sq. ft.	Duplex-Basic
04 114600 RK	R-7,200	Residential 7,200 sq. ft.	Duplex-Basic
03 107831 RK	R-5	Rural-5 Acre	Single Family Res-Combo
03 108175 RK	R-5	Rural-5 Acre	Single Family Res-Combo
04 114437 MH	R-5	Rural-5 Acre	Double Wide
03 110968 RK	R-5	Rural-5 Acre	Single Family Res-Combo
04 117794 RK	R-5	Rural-5 Acre	Single Family Res-Combo
04 113842 RK	R-5	Rural-5 Acre	Single Family Res-Combo
04 112392 MH	R-5	Rural-5 Acre	Double Wide
04 110684 RK	R-5	Rural-5 Acre	Single Family Res-Combo
03 107636 RK	R-5	Rural-5 Acre	Single Family Res-Combo
04 115401 RK	R-8,400	Residential 8,400 sq. ft.	SFR-Basic
04 114606 RK	R-9,600	Residential 9,600 sq. ft.	SFR-Basic
04 113496 RK	R-9,600	Residential 9,600 sq. ft.	Single Family Res-Combo
04 109848 RK	R-9,600	Residential 9,600 sq. ft.	Single Family Res-Combo
03 110491 RK	R-8,400	Residential 8,400 sq. ft.	Single Family Res-Combo
04 114594 RK	R-5	Rural-5 Acre	Single Family Res-Combo
04 111814 RK	R-5	Rural-5 Acre	Single Family Res-Combo
04 111024 MH	R-5	Rural-5 Acre	Double Wide
04 109540 RK	R-5	Rural-5 Acre	Single Family Res-Combo
04 116481 MH	R-5	Rural-5 Acre	Triple Wide
04 111838 MH	R-5	Rural-5 Acre	Single Wide
04 113200 RK	A-10	Agriculture-10 Acre	Single Family Res-Combo
03 111015 RK	RC	Rural Conservation	SFR-Basic
04 111692 RK	R-5	Rural-5 Acre	Single Family Res-Combo
04 115303 MH	R-5	Rural-5 Acre	Triple Wide
01 112708 000 01 RK	RRT-10	Rural Resource Transition-10	Accessory Apt Detached-Combo

Accessory Dwelling Units

Index # - File Name: 1.0022 - Single Family Dwellings Data\_Snohomish County.pdf

04 111299 MH	CITY	City	Double Wide
04 112425 RK	R-5	Rural-5 Acre	Single Family Res-Combo
04 113318 RK	R-5	Rural-5 Acre	Single Family Res-Combo
04 113951 RK	CITY	City	Duplex-Basic
01 111866 000 01 RK	A-10	Agriculture-10 Acre	Single Family Res-Combo
04 111562 RK	R-5	Rural-5 Acre	Single Family Res-Combo
04 100243 MH	R-5	Rural-5 Acre	Double Wide
04 112681 RK	R-7,200	Residential 7,200 sq. ft.	Single Family Res-Combo
03 108553 RK	CITY	City	Duplex-Basic
04 109803 RK	CITY	City	SFR-Basic
03 108725 RK	R-5	Rural-5 Acre	Single Family Res-Combo
03 105805 RK	CITY	City	Single Family Res-Combo
01 107293 000 01 RK	R-5	Rural-5 Acre	Single Family Res-Combo
04 119332 RK	CITY	City	Single Family Res-Combo
04 109278 MH	CITY	City	Double Wide
04 112227 RK	R-5	Rural-5 Acre	Single Family Res-Combo
04 114527 RK	R-5	Rural-5 Acre	Single Family Res-Combo
04 112068 RK	R-5	Rural-5 Acre	Single Family Res-Combo
04 110703 MH	R-7,200	Residential 7,200 sq. ft.	MH Park-Triple Wide
04 116907 MH	R-5	Rural-5 Acre	Double Wide
04 112222 MH	RRT-10	Rural Resource Transition-10	Triple Wide
03 106301 MH	R-5	Rural-5 Acre	Double Wide
04 113063 RK	R-5	Rural-5 Acre	Single Family Res-Combo
04 112993 RK	R-5	Rural-5 Acre	Single Family Res-Combo
00 101409 000 01 RK	CITY	City	Single Family Res-Combo
04 110470 RK	RRT-10	Rural Resource Transition-10	Single Family Res-Combo
04 100361 RK	R-5	Rural-5 Acre	Single Family Res-Combo
04 114785 RK	R-5	Rural-5 Acre	Single Family Res-Combo
04 120192 RK	R-5	Rural-5 Acre	Single Family Res-Combo
04 109160 MH	R-5	Rural-5 Acre	Double Wide
04 112771 RK	R-5	Rural-5 Acre	Single Family Res-Combo
04 117980 RK	R-5	Rural-5 Acre	Single Family Res-Combo
04 117982 RK	R-5	Rural-5 Acre	Single Family Res-Combo
04 112046 MH	R-5	Rural-5 Acre	Double Wide
04 113906 RK	CITY	City	Single Family Res-Combo
04 113844 RK	R-5	Rural-5 Acre	Single Family Res-Combo
03 109044 MH	R-5	Rural-5 Acre	Double Wide
04 109273 MH	R-5	Rural-5 Acre	Double Wide
03 110476 RK	R-5	Rural-5 Acre	Single Family Res-Combo
03 107965 MH	R-5	Rural-5 Acre	Double Wide
04 117056 RK	R-5	Rural-5 Acre	Single Family Res-Combo
04 115661 MH	R-5	Rural-5 Acre	Triple Wide
04 112483 RK	R-5	Rural-5 Acre	Single Family Res-Combo
04 120060 RK	R-5	Rural-5 Acre	Single Family Res-Combo
04 109044 RK	A-10	Agriculture-10 Acre	Duplex-Combo
04 109338 RK	R-5	Rural-5 Acre	Single Family Res-Combo
04 109825 MH	R-5	Rural-5 Acre	Triple Wide

Accessory Dwelling Units

Index # - File Name: 1.0022 - Single Family Dwellings Data\_Snohomish County.pdf

02 103287 000 01 RK	R-5	Rural-5 Acre	Single Family Res-Combo
04 118324 RK	R-5	Rural-5 Acre	Duplex-Combo
04 117615 RK	R-5	Rural-5 Acre	Single Family Res-Combo
04 112028 RK	R-5	Rural-5 Acre	Single Family Res-Combo
04 112304 RK	R-5	Rural-5 Acre	Single Family Res-Combo
04 116194 RK	R-5	Rural-5 Acre	Single Family Res-Combo
04 117055 RK	R-5	Rural-5 Acre	Single Family Res-Combo
04 100074 RK	RC	Rural Conservation	Single Family Res-Combo
04 108884 MH	R-5	Rural-5 Acre	Double Wide
03 107207 RK	R-5	Rural-5 Acre	Single Family Res-Combo
02 104277 000 01 RK	R-5	Rural-5 Acre	Single Family Res-Combo
04 111792 RK	R-5	Rural-5 Acre	Single Family Res-Combo
02 105888 MH	R-5	Rural-5 Acre	Double Wide
04 118660 RK	R-5	Rural-5 Acre	SFR-Basic
04 117857 RK	R-5	Rural-5 Acre	Accessory Apt Detached-Combo
04 111522 RK	R-5	Rural-5 Acre	Single Family Res-Combo
04 114330 RK	R-5	Rural-5 Acre	Single Family Res-Combo
04 113006 RK	R-5	Rural-5 Acre	Single Family Res-Combo
04 110836 RK	R-5	Rural-5 Acre	Single Family Res-Combo
04 115965 RK	R-5	Rural-5 Acre	Single Family Res-Combo
04 114524 001 00 RK	R-5	Rural-5 Acre	Single Family Res-Combo
04 108743 RK	R-5	Rural-5 Acre	Single Family Res-Combo
03 103381 RK	R-5	Rural-5 Acre	SFR-Basic
04 112050 RK	R-5	Rural-5 Acre	Single Family Res-Combo
03 104367 RK	R-5	Rural-5 Acre	Single Family Res-Combo
04 117585 RK	R-5	Rural-5 Acre	Single Family Res-Combo
04 110417 RK	TRIBES	Native American Land	Single Family Res-Combo
04 114089 MH	TRIBES	Native American Land	Double Wide
04 110402 RK	R-5	Rural-5 Acre	Single Family Res-Combo
04 117604 MH	R-5	Rural-5 Acre	Double Wide
03 109617 RK	RD	Rural Diversification	Single Family Res-Combo
04 116632 RK	R-5	Rural-5 Acre	Single Family Res-Combo
04 111287 RK	R-5	Rural-5 Acre	Single Family Res-Combo
04 117656 RK	R-9,600	Residential 9,600 sq. ft.	Single Family Res-Combo
03 106977 RK	R-5	Rural-5 Acre	Single Family Res-Combo
04 117925 MH	R-5	Rural-5 Acre	Double Wide
04 118191 RK	R-5	Rural-5 Acre	Single Family Res-Combo
04 113492 RK	R-5	Rural-5 Acre	Single Family Res-Combo
04 110037 RK	R-5	Rural-5 Acre	Accessory Apt Detached-Combo
04 110044 RK	R-5	Rural-5 Acre	Single Family Res-Combo
04 112959 RK	R-5	Rural-5 Acre	Single Family Res-Combo
04 109955 RK	R-5	Rural-5 Acre	Single Family Res-Combo
04 109961 RK	R-5	Rural-5 Acre	Single Family Res-Combo
04 120491 RK	R-5	Rural-5 Acre	Single Family Res-Combo
04 110995 RK	R-5	Rural-5 Acre	Single Family Res-Combo
04 110195 RK	RD	Rural Diversification	Single Family Res-Combo
04 115280 RK	R-5	Rural-5 Acre	Single Family Res-Combo

Accessory Dwelling Units

Index # - File Name: 1.0022 - Single Family Dwellings Data\_Snohomish County.pdf

04 110111 RK	RD	Rural Diversification	Single Family Res-Combo
04 115138 RK	RD	Rural Diversification	Single Family Res-Combo
04 110410 MH	RD	Rural Diversification	Double Wide
03 109356 RK	RD	Rural Diversification	Single Family Res-Combo
04 114023 MH	R-5	Rural-5 Acre	Double Wide
04 100125 RK	R-5	Rural-5 Acre	Single Family Res-Combo
04 109136 MH	RD	Rural Diversification	Double Wide
04 112286 RK	R-5	Rural-5 Acre	Single Family Res-Combo
04 117784 RK	R-5	Rural-5 Acre	Single Family Res-Combo
04 118185 RK	RC	Rural Conservation	SFR-Basic
04 111111 RK	R-5	Rural-5 Acre	Single Family Res-Combo
04 113185 MH	R-5	Rural-5 Acre	Double Wide
02 109555 MH	R-5	Rural-5 Acre	Double Wide
04 115816 RK	R-5	Rural-5 Acre	Single Family Res-Combo
03 109616 RK	R-5	Rural-5 Acre	Single Family Res-Combo
04 113401 RK	R-5	Rural-5 Acre	Single Family Res-Combo
04 109035 RK	RC	Rural Conservation	Single Family Res-Combo
03 109077 RK	RD	Rural Diversification	Single Family Res-Combo
04 115049 RK	R-5	Rural-5 Acre	Single Family Res-Combo
04 116622 MH	F	Forestry	Double Wide
04 111411 RK	R-5	Rural-5 Acre	Single Family Res-Combo
02 108493 000 01 MH	R-5	Rural-5 Acre	Double Wide
04 112371 RK	R-5	Rural-5 Acre	Single Family Res-Combo
01 105578 000 01 RK	R-5	Rural-5 Acre	Single Family Res-Combo
04 119029 RK	R-5	Rural-5 Acre	Single Family Res-Combo
04 109737 RK	R-5	Rural-5 Acre	Single Family Res-Combo
01 105859 000 01 MH	A-10	Agriculture-10 Acre	Double Wide
04 117107 RK	R-5	Rural-5 Acre	Single Family Res-Combo
04 115027 RK	RD	Rural Diversification	Single Family Res-Combo
04 119212 RK	R-5	Rural-5 Acre	Single Family Res-Combo
04 119079 RK	R-5	Rural-5 Acre	Single Family Res-Combo
04 113410 RK	RC	Rural Conservation	SFR-Basic
04 110074 MH	R-5	Rural-5 Acre	Triple Wide
03 109515 RK	R-5	Rural-5 Acre	SFR-Basic
04 109738 RK	R-5	Rural-5 Acre	Single Family Res-Combo
03 107001 MH	R-5	Rural-5 Acre	Double Wide
04 116670 RK	R-5	Rural-5 Acre	Accessory Apt Detached-Combo
04 100117 RK	F	Forestry	SFR-Basic
04 117508 RK	R-5	Rural-5 Acre	Single Family Res-Combo
04 119144 MH	R-5	Rural-5 Acre	Double Wide
04 117920 RK	R-5	Rural-5 Acre	Single Family Res-Combo
04 116280 RK	R-5	Rural-5 Acre	Single Family Res-Combo
01 106438 000 01 RK	R-5	Rural-5 Acre	Single Family Res-Combo
04 110621 RK	R-5	Rural-5 Acre	SFR-Basic
04 110627 RK	R-5	Rural-5 Acre	SFR-Basic
04 110465 RK	R-5	Rural-5 Acre	Single Family Res-Combo
04 110630 RK	R-5	Rural-5 Acre	SFR-Basic



Accessory Dwelling Units

Index # - File Name: 1.0022 - Single Family Dwellings Data\_Snohomish County.pdf

02 104845 000 01 RK	R-5	Rural-5 Acre	Single Family Res-Combo
04 112879 MH	R-5	Rural-5 Acre	Double Wide
04 100023 RK	R-5	Rural-5 Acre	Single Family Res-Combo
02 106955 000 01 RK	RD	Rural Diversification	Single Family Res-Combo
02 106464 000 01 RK	R-5	Rural-5 Acre	Single Family Res-Combo
02 109326 RK	R-5	Rural-5 Acre	Single Family Res-Combo
03 107381 RK	R-5	Rural-5 Acre	Accessory Apt Detached-Combo
04 112617 RK	R-5	Rural-5 Acre	SFR-Basic
00 103338 000 01 RK	R-5	Rural-5 Acre	Single Family Res-Combo
04 112268 MH	R-7,200	Residential 7,200 sq. ft.	Double Wide
04 108629 RK	RRT-10	Rural Resource Transition-10	Single Family Res-Combo
04 111492 RK	R-5	Rural-5 Acre	Single Family Res-Combo
04 111482 RK	R-5	Rural-5 Acre	Single Family Res-Combo
04 118861 RK	R-5	Rural-5 Acre	Single Family Res-Combo
03 111050 RK	R-5	Rural-5 Acre	Single Family Res-Combo
00 110399 000 01 RK	R-5	Rural-5 Acre	Single Family Res-Combo
04 116202 RK	R-5	Rural-5 Acre	Single Family Res-Combo
03 110648 MH	R-5	Rural-5 Acre	Double Wide
04 110605 RK	R-5	Rural-5 Acre	Single Family Res-Combo
03 108997 RK	R-5	Rural-5 Acre	Single Family Res-Combo
04 118951 MH	RRT-10	Rural Resource Transition-10	Double Wide
04 110079 RK	R-5	Rural-5 Acre	Single Family Res-Combo
04 113834 RK	R-5	Rural-5 Acre	Single Family Res-Combo
04 108866 RK	R-9,600	Residential 9,600 sq. ft.	Single Family Res-Combo
03 109483 MH	A-10	Agriculture-10 Acre	Double Wide
04 115232 RK	R-5	Rural-5 Acre	SFR-Basic
03 110901 RK	R-5	Rural-5 Acre	Single Family Res-Combo
04 109266 MH	R-5	Rural-5 Acre	Double Wide
04 108532 RK	R-5	Rural-5 Acre	Single Family Res-Combo
04 111531 RK	R-5	Rural-5 Acre	SFR-Basic
03 109905 RK	R-5	Rural-5 Acre	Single Family Res-Combo
04 116817 RK	R-5	Rural-5 Acre	Single Family Res-Combo
04 116977 RK	R-5	Rural-5 Acre	Single Family Res-Combo
04 115117 RK	R-5	Rural-5 Acre	SFR-Basic
04 117739 MH	R-5	Rural-5 Acre	Double Wide
04 113297 RK	F	Forestry	Single Family Res-Combo
04 113643 RK	R-5	Rural-5 Acre	Single Family Res-Combo
04 109977 RK	R-5	Rural-5 Acre	Single Family Res-Combo
03 107301 RK	R-5	Rural-5 Acre	Single Family Res-Combo
03 111056 RK	R-5	Rural-5 Acre	Single Family Res-Combo
04 116333 RK	R-5	Rural-5 Acre	Single Family Res-Combo
03 106659 RK	R-5	Rural-5 Acre	Single Family Res-Combo
01 104706 000 01 RK	R-5	Rural-5 Acre	Single Family Res-Combo
04 119519 RK	R-5	Rural-5 Acre	Single Family Res-Combo
02 106163 000 01 RK	R-5	Rural-5 Acre	Single Family Res-Combo
03 106862 MH	R-5	Rural-5 Acre	Triple Wide
04 116024 MH	R-5	Rural-5 Acre	Double Wide

Accessory Dwelling Units

Index # - File Name: 1.0022 - Single Family Dwellings Data\_Snohomish County.pdf

04 112247 RK	R-5	Rural-5 Acre	Single Family Res-Combo
05 102088 RK	R-5	Rural-5 Acre	Single Family Res-Combo
04 120845 RK	F	Forestry	Single Family Res-Combo
04 117186 RK	R-5	Rural-5 Acre	Single Family Res-Combo
05 116785 RK	RRT-10	Rural Resource Transition-10	Single Family Res-Combo
03 105055 000 01 RK	A-10	Agriculture-10 Acre	Single Family Res-Combo
04 100213 RK	R-5	Rural-5 Acre	Single Family Res-Combo
05 100534 RK	R-5	Rural-5 Acre	Single Family Res-Combo
05 122393 MH	R-5	Rural-5 Acre	Triple Wide
05 118087 RK	R-5	Rural-5 Acre	Single Family Res-Combo
05 123417 MH	R-5	Rural-5 Acre	Single Wide
05 120684 RK	RRT-10	Rural Resource Transition-10	SFR-Basic
05 126175 RK	R-5	Rural-5 Acre	SFR-Basic
05 124366 RK	F	Forestry	Single Family Res-Combo
04 108866 001 00 RK	R-9,600	Residential 9,600 sq. ft.	Single Family Res-Combo
05 124712 RK	CITY	City	Single Family Res-Combo
05 118372 RK	R-9,600	Residential 9,600 sq. ft.	Single Family Res-Combo
05 124952 MH	R-5	Rural-5 Acre	Double Wide
05 126568 RK	R-5	Rural-5 Acre	Single Family Res-Combo
02 108330 000 01 RK	R-5	Rural-5 Acre	Single Family Res-Combo
04 112221 RK	R-5	Rural-5 Acre	Single Family Res-Combo
04 121029 RK	R-5	Rural-5 Acre	SFR-Basic
03 100516 000 01 RK	F	Forestry	Single Family Res-Combo
05 117025 RK	R-5	Rural-5 Acre	SFR-Basic
05 101669 RK	R-5	Rural-5 Acre	Single Family Res-Combo
05 117882 RK	R-5	Rural-5 Acre	Single Family Res-Combo
05 120377 RK	R-5	Rural-5 Acre	SFR-Basic
05 120258 RK	PRD-9,600	Residential 9,600 sq. ft.	SFR-Basic
05 120259 RK	PRD-9,600	Residential 9,600 sq. ft.	SFR-Basic
05 120260 RK	PRD-9,600	Residential 9,600 sq. ft.	SFR-Basic
05 120261 RK	PRD-9,600	Residential 9,600 sq. ft.	SFR-Basic
05 120262 RK	PRD-9,600	Residential 9,600 sq. ft.	SFR-Basic
05 120263 RK	PRD-9,600	Residential 9,600 sq. ft.	SFR-Basic
05 123004 RK	R-5	Rural-5 Acre	Single Family Res-Combo
05 101241 RK	F	Forestry	Single Family Res-Combo
02 107211 000 01 RK	R-5	Rural-5 Acre	Single Family Res-Combo
05 123402 RK	R-9,600	Residential 9,600 sq. ft.	Single Family Res-Combo
05 121064 MH	R-5	Rural-5 Acre	Double Wide
05 101245 MH	R-5	Rural-5 Acre	Single Wide
05 119438 RK	F	Forestry	Single Family Res-Combo
05 100810 RK	CITY	City	Single Family Res-Combo
05 123683 RK	R-5	Rural-5 Acre	Single Family Res-Combo
05 125181 RK	R-5	Rural-5 Acre	Single Family Res-Combo
05 127606 MH	R-5	Rural-5 Acre	Triple Wide
05 117763 RK	F	Forestry	Single Family Res-Combo
05 122097 RK	R-5	Rural-5 Acre	Single Family Res-Combo
05 126311 RK	R-5	Rural-5 Acre	Single Family Res-Combo

Accessory Dwelling Units

Index # - File Name: 1.0022 - Single Family Dwellings Data\_Snohomish County.pdf

05 126308 RK	R-5	Rural-5 Acre	Single Family Res-Combo
04 118505 RK	RD	Rural Diversification	Single Family Res-Combo
04 116276 MH	R-5	Rural-5 Acre	Double Wide
05 116059 RK	R-5	Rural-5 Acre	Single Family Res-Combo
05 124339 RK	R-5	Rural-5 Acre	SFR-Basic
05 116543 RK	R-5	Rural-5 Acre	Single Family Res-Combo
05 126381 RK	R-5	Rural-5 Acre	Single Family Res-Combo
05 101214 RK	R-5	Rural-5 Acre	Single Family Res-Combo
05 120185 RK	MR	Multiple Residential	Duplex-Basic
05 121014 RK	R-5	Rural-5 Acre	Single Family Res-Combo
05 117966 RK	R-9,600	Residential 9,600 sq. ft.	Accessory Apt Detached-Combo
05 116449 RK	R-5	Rural-5 Acre	Single Family Res-Combo
03 109037 000 01 RK	R-5	Rural-5 Acre	Single Family Res-Combo
04 121364 RK	R-5	Rural-5 Acre	SFR-Basic
05 117343 RK	R-9,600	Residential 9,600 sq. ft.	Single Family Res-Combo
05 121443 RK	R-5	Rural-5 Acre	Single Family Res-Combo
04 120526 RK	R-5	Rural-5 Acre	Single Family Res-Combo
05 116133 RK	R-5	Rural-5 Acre	Single Family Res-Combo
05 121159 RK	R-5	Rural-5 Acre	Single Family Res-Combo
05 117405 RK	RRT-10	Rural Resource Transition-10	Single Family Res-Combo
05 117968 RK	R-5	Rural-5 Acre	Single Family Res-Combo
05 116235 RK	R-5	Rural-5 Acre	Single Family Res-Combo
05 124374 RK	R-5	Rural-5 Acre	Single Family Res-Combo
05 101680 MH	R-5	Rural-5 Acre	Double Wide
04 117516 RK	R-5	Rural-5 Acre	Single Family Res-Combo
05 123033 RK	RC	Rural Conservation	Single Family Res-Combo
05 100427 RK	RC	Rural Conservation	SFR-Basic
05 122928 RK	R-5	Rural-5 Acre	Single Family Res-Combo
05 117562 RK	RC	Rural Conservation	Single Family Res-Combo
05 120099 RK	R-5	Rural-5 Acre	Single Family Res-Combo
04 115175 RK	R-5	Rural-5 Acre	Single Family Res-Combo
05 101684 RK	R-5	Rural-5 Acre	Single Family Res-Combo
04 121567 RK	R-5	Rural-5 Acre	Single Family Res-Combo
05 100686 RK	R-5	Rural-5 Acre	Single Family Res-Combo
05 100695 RK	R-5	Rural-5 Acre	Single Family Res-Combo
04 118954 RK			Single Family Res-Combo
05 117877 MH	RD	Rural Diversification	Double Wide
05 123568 RK	A-10	Agriculture-10 Acre	Single Family Res-Combo
04 116963 RK	R-5	Rural-5 Acre	Single Family Res-Combo
05 121487 MH	RD	Rural Diversification	Double Wide
05 117075 RK	R-5	Rural-5 Acre	Single Family Res-Combo
05 116369 RK	RD	Rural Diversification	Single Family Res-Combo
05 122303 RK	R-5	Rural-5 Acre	SFR-Basic
05 120284 MH	R-5	Rural-5 Acre	Single Wide
05 119593 RK	R-5	Rural-5 Acre	Single Family Res-Combo
05 122339 MH	R-5	Rural-5 Acre	Double Wide
05 123929 MH	R-5	Rural-5 Acre	Triple Wide

Accessory Dwelling Units

Index # - File Name: 1.0022 - Single Family Dwellings Data\_Snohomish County.pdf

05 121027 RK	A-10	Agriculture-10 Acre	Single Family Res-Combo
05 120195 MH	R-5	Rural-5 Acre	Single Wide
05 123022 RK	R-5	Rural-5 Acre	Single Family Res-Combo
05 102099 RK	R-5	Rural-5 Acre	Single Family Res-Combo
05 124020 RK	R-5	Rural-5 Acre	Single Family Res-Combo
05 123799 RK	R-5	Rural-5 Acre	Accessory Apt Detached-Combo
05 121345 RK	R-5	Rural-5 Acre	Single Family Res-Combo
05 117119 MH	R-5	Rural-5 Acre	Double Wide
05 125081 RK	R-5	Rural-5 Acre	Single Family Res-Combo
05 120975 RK	R-5	Rural-5 Acre	Single Family Res-Combo
05 100752 RK	R-5	Rural-5 Acre	Accessory Apt Detached-Combo
05 119163 MH	R-9,600	Residential 9,600 sq. ft.	Double Wide
04 119589 RK	R-5	Rural-5 Acre	Single Family Res-Combo
05 118625 RK	R-5	Rural-5 Acre	Single Family Res-Combo
05 121556 RK	R-5	Rural-5 Acre	Single Family Res-Combo
05 121555 RK	R-5	Rural-5 Acre	Single Family Res-Combo
05 121559 RK	R-5	Rural-5 Acre	SFR-Basic
05 116068 RK	R-5	Rural-5 Acre	Single Family Res-Combo
05 116913 RK	R-5	Rural-5 Acre	Single Family Res-Combo
05 100522 RK	R-5	Rural-5 Acre	Single Family Res-Combo
05 121055 RK	R-5	Rural-5 Acre	Single Family Res-Combo
05 120241 MH	R-5	Rural-5 Acre	Triple Wide
04 120331 RK	R-5	Rural-5 Acre	Single Family Res-Combo
04 121318 RK	R-5	Rural-5 Acre	Single Family Res-Combo
05 117940 RK	R-5	Rural-5 Acre	Single Family Res-Combo
05 125088 MH	R-5	Rural-5 Acre	Triple Wide
05 118301 RK	R-5	Rural-5 Acre	Single Family Res-Combo
05 119953 MH	R-5	Rural-5 Acre	Double Wide
05 117620 RK	R-5	Rural-5 Acre	Single Family Res-Combo
05 120992 RK	R-5	Rural-5 Acre	Single Family Res-Combo
04 117131 RK	A-10	Agriculture-10 Acre	Single Family Res-Combo
05 122324 RK	R-5	Rural-5 Acre	SFR-Basic
03 109303 RK	R-5	Rural-5 Acre	Single Family Res-Combo
05 118340 RK	R-5	Rural-5 Acre	SFR-Basic
05 117726 RK	R-5	Rural-5 Acre	Single Family Res-Combo
05 125864 RK	R-5	Rural-5 Acre	Single Family Res-Combo
05 121787 RK	R-5	Rural-5 Acre	Single Family Res-Combo
05 127594 RK	R-5	Rural-5 Acre	Single Family Res-Combo
05 125876 RK	R-5	Rural-5 Acre	Single Family Res-Combo
05 119848 RK	R-5	Rural-5 Acre	Single Family Res-Combo
05 101981 MH	R-5	Rural-5 Acre	Double Wide
05 119907 RK	RC	Rural Conservation	Single Family Res-Combo
05 126227 RK	R-5	Rural-5 Acre	Single Family Res-Combo
05 121398 RK	R-5	Rural-5 Acre	Single Family Res-Combo
04 121315 RK	R-5	Rural-5 Acre	Single Family Res-Combo
05 117619 RK	R-5	Rural-5 Acre	Single Family Res-Combo
05 116258 RK	R-5	Rural-5 Acre	Single Family Res-Combo

Accessory Dwelling Units

Index # - File Name: 1.0022 - Single Family Dwellings Data\_Snohomish County.pdf

04 118621 RK	R-5	Rural-5 Acre	Single Family Res-Combo
04 111361 RK	R-5	Rural-5 Acre	Single Family Res-Combo
05 121895 RK	R-5	Rural-5 Acre	Accessory Apt Detached-Combo
05 119743 RK	R-5	Rural-5 Acre	Single Family Res-Combo
05 119613 RK	R-5	Rural-5 Acre	Accessory Apt Detached-Combo
05 118863 RK	R-5	Rural-5 Acre	Single Family Res-Combo
05 116939 RK	R-5	Rural-5 Acre	Single Family Res-Combo
05 120874 RK	R-5	Rural-5 Acre	Single Family Res-Combo
05 101955 RK	R-5	Rural-5 Acre	Single Family Res-Combo
05 101954 RK	R-5	Rural-5 Acre	Single Family Res-Combo
05 124780 MH	R-5	Rural-5 Acre	Double Wide
05 124646 RK	R-5	Rural-5 Acre	Single Family Res-Combo
05 122305 RK	R-5	Rural-5 Acre	Single Family Res-Combo
05 123195 RK	R-5	Rural-5 Acre	Single Family Res-Combo
05 117433 RK	R-5	Rural-5 Acre	Single Family Res-Combo
05 122390 MH	R-5	Rural-5 Acre	Double Wide
05 100889 RK	CITY	City	Single Family Res-Combo
05 123427 RK	R-5	Rural-5 Acre	Single Family Res-Combo
05 116541 RK	RRT-10	Rural Resource Transition-10	Single Family Res-Combo
05 119877 RK	SA-1	Suburban Agriculture-1 Acre	Single Family Res-Combo
05 123254 RK	CITY	City	Duplex-Combo
05 122279 RK	R-5	Rural-5 Acre	Single Family Res-Combo
05 118270 RK	RRT-10	Rural Resource Transition-10	Single Family Res-Combo
05 124581 RK	R-5	Rural-5 Acre	Single Family Res-Combo
05 121440 RK	F	Forestry	Single Family Res-Combo
05 101114 RK	R-5	Rural-5 Acre	Single Family Res-Combo
05 116440 RK	R-5	Rural-5 Acre	Single Family Res-Combo
05 123805 RK	R-5	Rural-5 Acre	Single Family Res-Combo
05 123523 RK	R-5	Rural-5 Acre	Single Family Res-Combo
04 115751 RK	R-5	Rural-5 Acre	Single Family Res-Combo
05 120539 RK	CITY	City	Single Family Res-Combo
04 114738 RK	RRT-10	Rural Resource Transition-10	Single Family Res-Combo
04 120708 RK	R-5	Rural-5 Acre	Single Family Res-Combo
05 121260 RK	R-5	Rural-5 Acre	Single Family Res-Combo
05 117295 MH	R-5	Rural-5 Acre	Double Wide
05 119882 RK	R-5	Rural-5 Acre	Single Family Res-Combo
05 118348 RK	CITY	City	Single Family Res-Combo
05 100493 RK	R-5	Rural-5 Acre	Single Family Res-Combo
05 119809 RK	R-7,200	Residential 7,200 sq. ft.	Single Family Res-Combo
05 123797 RK	RRT-10	Rural Resource Transition-10	Single Family Res-Combo
05 116255 RK	R-5	Rural-5 Acre	Single Family Res-Combo
05 124099 RK	R-5	Rural-5 Acre	Single Family Res-Combo
05 100483 RK	R-5	Rural-5 Acre	Single Family Res-Combo
05 100764 RK	A-10	Agriculture-10 Acre	Single Family Res-Combo
04 117448 RK	R-5	Rural-5 Acre	Single Family Res-Combo
05 118472 RK	CITY	City	Single Family Res-Combo
05 100474 RK	CITY	City	Single Family Res-Combo

Accessory Dwelling Units

Index # - File Name: 1.0022 - Single Family Dwellings Data\_Snohomish County.pdf

05 101003 RK	R-5	Rural-5 Acre	Single Family Res-Combo
05 117775 RK	R-5	Rural-5 Acre	Single Family Res-Combo
05 123963 RK	CITY	City	Single Family Res-Combo
05 100919 RK	CITY	City	Single Family Res-Combo
05 119952 RK	R-5	Rural-5 Acre	Single Family Res-Combo
05 119948 RK	R-5	Rural-5 Acre	Single Family Res-Combo
05 101275 RK	R-5	Rural-5 Acre	Single Family Res-Combo
05 100531 RK	R-5	Rural-5 Acre	Single Family Res-Combo
05 118344 MH	R-5	Rural-5 Acre	Double Wide
05 126868 RK	CITY	City	Single Family Res-Combo
04 114612 RK	CITY	City	Single Family Res-Combo
05 118059 RK	R-5	Rural-5 Acre	Single Family Res-Combo
04 121112 RK	R-5	Rural-5 Acre	Single Family Res-Combo
02 110203 000 01 RK	R-5	Rural-5 Acre	Single Family Res-Combo
05 116492 RK	R-5	Rural-5 Acre	Single Family Res-Combo
04 108965 RK	R-5	Rural-5 Acre	Single Family Res-Combo
05 121408 RK	R-5	Rural-5 Acre	Single Family Res-Combo
05 119531 RK	CITY	City	Single Family Res-Combo
05 126270 RK	CITY	City	Single Family Res-Combo
05 120640 MH	R-5	Rural-5 Acre	Double Wide
05 118900 RK	R-5	Rural-5 Acre	Single Family Res-Combo
05 100557 RK	R-5	Rural-5 Acre	Single Family Res-Combo
05 119719 RK	RRT-10	Rural Resource Transition-1	Single Family Res-Combo
05 119633 RK	RRT-10	Rural Resource Transition-1	Single Family Res-Combo
05 117049 RK	RRT-10	Rural Resource Transition-1	Single Family Res-Combo
05 100057 MH	RRT-10	Rural Resource Transition-1	Double Wide
04 117609 RK	RRT-10	Rural Resource Transition-1	Single Family Res-Combo
05 120664 RK	R-5	Rural-5 Acre	Single Family Res-Combo
05 101629 RK	R-5	Rural-5 Acre	Single Family Res-Combo
05 101645 RK	R-5	Rural-5 Acre	Single Family Res-Combo
05 117502 RK	R-5	Rural-5 Acre	Single Family Res-Combo
05 122488 RK	R-5	Rural-5 Acre	Single Family Res-Combo
05 125858 MH	RRT-10	Rural Resource Transition-1	Triple Wide
04 121796 MH	R-5	Rural-5 Acre	Double Wide
05 118029 RK	R-5	Rural-5 Acre	Single Family Res-Combo
05 101623 RK	A-10	Agriculture-10 Acre	Single Family Res-Combo
05 100388 RK	R-5	Rural-5 Acre	Single Family Res-Combo
05 117980 RK	R-5	Rural-5 Acre	Single Family Res-Combo
05 119539 RK	R-9,600	Residential 9,600 sq. ft.	Single Family Res-Combo
05 126554 MH	F	Forestry	Double Wide
05 118681 RK	R-5	Rural-5 Acre	Single Family Res-Combo
05 101961 RK	R-5	Rural-5 Acre	Single Family Res-Combo
04 121368 RK	R-5	Rural-5 Acre	Single Family Res-Combo
05 117447 RK	R-5	Rural-5 Acre	Single Family Res-Combo
05 119054 MH	R-5	Rural-5 Acre	Double Wide
05 125777 RK	R-9,600	Residential 9,600 sq. ft.	Single Family Res-Combo
05 122368 RK	R-7,200	Residential 7,200 sq. ft.	Duplex-Basic

Accessory Dwelling Units

Index # - File Name: 1.0022 - Single Family Dwellings Data\_Snohomish County.pdf

05 100713 RK	LDMR	Low Density Multiple Reside	Single Family Res-Combo
05 117753 RK	R-5	Rural-5 Acre	Single Family Res-Combo
05 125674 RK	R-9,600	Residential 9,600 sq. ft.	Single Family Res-Combo
05 116334 RK	R-7,200	Residential 7,200 sq. ft.	Duplex-Basic
05 123712 RK	R-7,200	Residential 7,200 sq. ft.	Single Family Res-Combo
05 121431 RK	WFB	Waterfront Beach	Single Family Res-Combo
05 122090 RK	R-9,600	Residential 9,600 sq. ft.	Single Family Res-Combo
04 121458 RK	R-9,600	Residential 9,600 sq. ft.	Single Family Res-Combo
05 101182 RK	R-9,600	Residential 9,600 sq. ft.	Single Family Res-Combo
05 121124 RK	R-5	Rural-5 Acre	Single Family Res-Combo
05 118324 RK	R-9,600	Residential 9,600 sq. ft.	Single Family Res-Combo
04 118553 RK	R-5	Rural-5 Acre	Single Family Res-Combo
05 120934 RK	R-5	Rural-5 Acre	Single Family Res-Combo
03 102916 000 01 RK	R-5	Rural-5 Acre	Single Family Res-Combo
05 125078 MH	R-5	Rural-5 Acre	Triple Wide
05 120952 RK	R-5	Rural-5 Acre	Single Family Res-Combo
05 121399 MH	F	Forestry	Double Wide
05 123466 MH	F	Forestry	Double Wide
03 102147 000 01 RK	R-5	Rural-5 Acre	Accessory Apt Detached-Combo
05 125822 MH	R-5	Rural-5 Acre	Triple Wide
05 119424 RK	F	Forestry	Single Family Res-Combo
05 117215 RK	R-5	Rural-5 Acre	Single Family Res-Combo
05 117349 MH	R-5	Rural-5 Acre	Double Wide
05 121538 RK	A-10	Agriculture-10 Acre	Single Family Res-Combo
05 119402 RK	R-5	Rural-5 Acre	Single Family Res-Combo
05 101630 RK	R-5	Rural-5 Acre	Single Family Res-Combo
05 116249 RK	R-5	Rural-5 Acre	Single Family Res-Combo
05 123281 RK	R-5	Rural-5 Acre	Single Family Res-Combo
04 116975 RK	F	Forestry	Single Family Res-Combo
05 101678 MH	R-5	Rural-5 Acre	Double Wide
05 118409 RK	R-5	Rural-5 Acre	Single Family Res-Combo
05 101318 RK	R-5	Rural-5 Acre	Single Family Res-Combo
05 121156 MH	R-5	Rural-5 Acre	Double Wide
04 117601 MH	R-5	Rural-5 Acre	Triple Wide
05 101867 RK	R-5	Rural-5 Acre	Single Family Res-Combo
05 124460 RK	R-5	Rural-5 Acre	Single Family Res-Combo
05 122125 RK	R-5	Rural-5 Acre	Single Family Res-Combo
05 120914 RK	R-5	Rural-5 Acre	Single Family Res-Combo
05 116130 RK	R-5	Rural-5 Acre	Single Family Res-Combo
05 123054 RK	R-5	Rural-5 Acre	Single Family Res-Combo
05 101879 MH	R-5	Rural-5 Acre	Double Wide
05 120452 RK	R-9,600	Residential 9,600 sq. ft.	Single Family Res-Combo
05 120454 RK	R-9,600	Residential 9,600 sq. ft.	Single Family Res-Combo
05 120865 RK	R-5	Rural-5 Acre	Single Family Res-Combo
05 117067 RK	F	Forestry	Single Family Res-Combo
05 116272 RK	F	Forestry	Single Family Res-Combo
05 125828 RK	R-12,500	Residential 12,500 sq. ft.	SFR-Basic

Accessory Dwelling Units

Index # - File Name: 1.0022 - Single Family Dwellings Data\_Snohomish County.pdf

05 122178 RK	R-12,500	Residential 12,500 sq. ft.	Single Family Res-Combo
05 117947 RK	R-12,500	Residential 12,500 sq. ft.	SFR-Basic
05 101841 RK	WFB	Waterfront Beach	Single Family Res-Combo
05 121228 RK	R-8,400 : WFB	Residential 8,400 sq. ft. : Wa	Single Family Res-Combo
05 121229 RK	R-8,400 : WFB	Residential 8,400 sq. ft. : Wa	Single Family Res-Combo
05 125677 RK	R-5	Rural-5 Acre	Single Family Res-Combo
05 117028 RK	R-5	Rural-5 Acre	Single Family Res-Combo
05 118821 RK	R-5	Rural-5 Acre	Single Family Res-Combo
05 127271 MH	F	Forestry	Double Wide
05 117437 RK	R-9,600	Residential 9,600 sq. ft.	Single Family Res-Combo
05 118481 MH	PRD-20,000(M	Residential 20,000 sq. ft.	Double Wide
04 111285 RK	R-5	Rural-5 Acre	Duplex-Combo
05 119718 RK	F	Forestry	SFR-Basic
05 119725 RK	F	Forestry	SFR-Basic
05 119861 RK	F	Forestry	SFR-Basic
05 117503 RK	F	Forestry	SFR-Basic
05 123260 RK	F	Forestry	SFR-Basic
05 120695 RK	F	Forestry	Single Family Res-Combo
05 121656 RK	R-5	Rural-5 Acre	Single Family Res-Combo
05 117779 RK	R-5	Rural-5 Acre	Single Family Res-Combo
05 124716 RK	R-5	Rural-5 Acre	Single Family Res-Combo
04 113425 MH	R-5	Rural-5 Acre	Double Wide
05 125379 RK	R-5	Rural-5 Acre	Single Family Res-Combo
03 102812 000 01 RK	R-5	Rural-5 Acre	Single Family Res-Combo
05 121999 RK	R-5	Rural-5 Acre	Single Family Res-Combo
05 123914 RK	R-9,600	Residential 9,600 sq. ft.	Single Family Res-Combo
05 121078 RK	R-5	Rural-5 Acre	Single Family Res-Combo
05 117982 RK	R-5	Rural-5 Acre	Accessory Apt Detached-Combo
05 122209 RK	R-5	Rural-5 Acre	Single Family Res-Combo
05 119154 RK	MR	Multiple Residential	Single Family Res-Combo
05 100244 RK	R-9,600	Residential 9,600 sq. ft.	Duplex-Basic
05 100245 RK	R-9,600	Residential 9,600 sq. ft.	Duplex-Basic
05 100247 RK	R-9,600	Residential 9,600 sq. ft.	Duplex-Basic
05 117847 RK	R-5	Rural-5 Acre	Single Family Res-Combo
05 121227 RK	R-5	Rural-5 Acre	Single Family Res-Combo
05 122276 RK	R-5	Rural-5 Acre	Single Family Res-Combo
04 121074 RK	R-9,600	Residential 9,600 sq. ft.	Single Family Res-Combo
05 120946 RK	R-5	Rural-5 Acre	Single Family Res-Combo
05 121438 RK	R-5	Rural-5 Acre	Single Family Res-Combo
05 123577 RK	A-10	Agriculture-10 Acre	Single Family Res-Combo
05 125641 RK	R-8,400	Residential 8,400 sq. ft.	Duplex-Combo
00 106473 000 01 RK	R-5	Rural-5 Acre	Single Family Res-Combo
05 123582 RK	F	Forestry	Single Family Res-Combo
05 119916 RK	R-9,600	Residential 9,600 sq. ft.	Accessory Apt Detached-Combo
05 121263 RK	R-9,600	Residential 9,600 sq. ft.	Single Family Res-Combo
05 116419 RK	MR	Multiple Residential	Single Family Res-Combo
04 121479 RK	R-5	Rural-5 Acre	Single Family Res-Combo



Accessory Dwelling Units

Index # - File Name: 1.0022 - Single Family Dwellings Data\_Snohomish County.pdf

05 101894 RK	R-5	Rural-5 Acre	Single Family Res-Combo
05 119514 RK	R-5	Rural-5 Acre	Single Family Res-Combo
04 117959 RK	R-5	Rural-5 Acre	Single Family Res-Combo
04 120998 RK	R-5	Rural-5 Acre	Accessory Apt Detached-Combo
05 100083 RK	R-5 : SA-1	Rural-5 Acre : Suburban Agri	Single Family Res-Combo
05 100734 RK	R-5	Rural-5 Acre	Single Family Res-Combo
05 116829 RK	CRC : R-5	Clearview Rural Commercial	Single Family Res-Combo
05 117499 RK	R-5	Rural-5 Acre	Single Family Res-Combo
04 113506 RK	R-9,600	Residential 9,600 sq. ft.	Single Family Res-Combo
05 120329 RK	F	Forestry	Single Family Res-Combo
05 122336 MH	R-5	Rural-5 Acre	Double Wide
05 101626 RK	R-5	Rural-5 Acre	Single Family Res-Combo
04 119971 RK	F	Forestry	Single Family Res-Combo
05 124783 RK	F	Forestry	Single Family Res-Combo
05 122233 RK	R-5	Rural-5 Acre	Single Family Res-Combo
05 118916 RK	R-5	Rural-5 Acre	Single Family Res-Combo
05 123951 RK	R-5	Rural-5 Acre	Single Family Res-Combo
04 118773 RK	R-5	Rural-5 Acre	Single Family Res-Combo
02 109927 000 01 MH	R-5	Rural-5 Acre	Double Wide
05 124259 MH	R-5	Rural-5 Acre	Triple Wide
05 117024 RK	RD	Rural Diversification	Single Family Res-Combo
05 120326 RK	R-5	Rural-5 Acre	Single Family Res-Combo
05 116365 RK	F	Forestry	Single Family Res-Combo
05 101090 RK	R-5	Rural-5 Acre	Single Family Res-Combo
05 121795 RK	R-5	Rural-5 Acre	Single Family Res-Combo
03 107876 000 01 RK	R-5	Rural-5 Acre	Single Family Res-Combo
05 127092 RK	R-5	Rural-5 Acre	Single Family Res-Combo
04 119134 RK	R-5	Rural-5 Acre	Single Family Res-Combo
05 127393 RK	R-5	Rural-5 Acre	SFR-Basic
05 122239 RK	R-5	Rural-5 Acre	Single Family Res-Combo
05 125788 RK	R-5	Rural-5 Acre	SFR-Basic
05 123912 MH	R-5	Rural-5 Acre	Double Wide
05 120059 RK	A-10	Agriculture-10 Acre	Single Family Res-Combo
05 100975 MH	R-5	Rural-5 Acre	Double Wide
05 116481 RK	R-5	Rural-5 Acre	Single Family Res-Combo
05 124955 MH	R-5	Rural-5 Acre	Double Wide
05 120888 RK	R-5	Rural-5 Acre	Single Family Res-Combo
05 124447 RK	R-5	Rural-5 Acre	Single Family Res-Combo
05 116808 RK	R-5	Rural-5 Acre	Single Family Res-Combo
05 124045 RK	R-5	Rural-5 Acre	SFR-Basic
05 100707 RK	R-5	Rural-5 Acre	Single Family Res-Combo
05 117698 RK	R-5	Rural-5 Acre	Single Family Res-Combo
05 118903 RK	R-5	Rural-5 Acre	Single Family Res-Combo
05 100479 RK	R-5	Rural-5 Acre	Single Family Res-Combo
04 120233 RK	R-5	Rural-5 Acre	Single Family Res-Combo
04 121476 RK	R-5	Rural-5 Acre	Single Family Res-Combo
05 117793 RK	SA-1	Suburban Agriculture-1 Acre	Single Family Res-Combo

Accessory Dwelling Units

Index # - File Name: 1.0022 - Single Family Dwellings Data\_Snohomish County.pdf

05 121671 MH	F : RC	Forestry : Rural Conservation	Double Wide
05 120691 MH	RRT-10	Rural Resource Transition-10	Triple Wide
05 123457 RK	F	Forestry	Single Family Res-Combo
03 103716 000 01 RK	R-5	Rural-5 Acre	Single Family Res-Combo
01 108063 000 01 RK	R-5	Rural-5 Acre	Single Family Res-Combo
05 117790 MH	R-5	Rural-5 Acre	MH Park-Triple Wide
04 119420 RK	R-5	Rural-5 Acre	Single Family Res-Combo
05 122259 RK	R-5	Rural-5 Acre	Single Family Res-Combo
05 117010 RK	R-5	Rural-5 Acre	Single Family Res-Combo
05 116790 RK	R-5	Rural-5 Acre	Duplex-Combo
05 100733 RK	A-10 : R-5	Agriculture-10 Acre : Rural-5	Single Family Res-Combo
04 118662 RK	R-5	Rural-5 Acre	Single Family Res-Combo
04 120443 RK	R-5	Rural-5 Acre	Single Family Res-Combo
03 104123 000 01 MH	R-5	Rural-5 Acre	Double Wide
05 117915 RK	R-5	Rural-5 Acre	Single Family Res-Combo
04 118961 RK	R-5	Rural-5 Acre	Single Family Res-Combo
05 120169 RK	R-5	Rural-5 Acre	Single Family Res-Combo
05 122100 RK	R-5	Rural-5 Acre	Single Family Res-Combo
05 122482 RK	R-5	Rural-5 Acre	Single Family Res-Combo
05 101673 RK	R-5	Rural-5 Acre	Single Family Res-Combo
05 100706 RK	R-5	Rural-5 Acre	Single Family Res-Combo
05 101979 RK	R-5	Rural-5 Acre	Single Family Res-Combo
05 100024 RK	R-5	Rural-5 Acre	SFR-Basic
05 100021 RK	R-5	Rural-5 Acre	Single Family Res-Combo
05 100132 RK	R-5	Rural-5 Acre	SFR-Basic
05 100023 RK	R-5	Rural-5 Acre	Single Family Res-Combo
05 100133 RK	R-5	Rural-5 Acre	SFR-Basic
05 100134 RK	R-5	Rural-5 Acre	SFR-Basic
05 100026 RK	R-5	Rural-5 Acre	SFR-Basic
05 101012 RK	R-5	Rural-5 Acre	Single Family Res-Combo
05 100969 RK	R-5	Rural-5 Acre	Duplex-Combo
05 100178 RK	R-5	Rural-5 Acre	Single Family Res-Combo
04 109591 RK	R-5	Rural-5 Acre	Duplex-Combo
05 121195 RK	R-5	Rural-5 Acre	SFR-Basic
05 120334 RK	R-5	Rural-5 Acre	Single Family Res-Combo
05 101888 RK	R-5	Rural-5 Acre	Single Family Res-Combo
05 101895 RK	R-5	Rural-5 Acre	Single Family Res-Combo
05 117939 RK	R-5	Rural-5 Acre	Single Family Res-Combo
05 116284 RK	R-5	Rural-5 Acre	Single Family Res-Combo
05 119331 RK	R-5	Rural-5 Acre	Single Family Res-Combo
05 121300 RK	R-5	Rural-5 Acre	SFR-Basic
05 117115 RK	R-5	Rural-5 Acre	SFR-Basic
05 117116 RK	R-5	Rural-5 Acre	SFR-Basic
05 116916 MH	R-5	Rural-5 Acre	Double Wide
05 123067 RK	R-5	Rural-5 Acre	SFR-Basic
05 120142 RK	R-5	Rural-5 Acre	Single Family Res-Combo
05 123673 RK	R-5	Rural-5 Acre	Single Family Res-Combo

Accessory Dwelling Units

Index # - File Name: 1.0022 - Single Family Dwellings Data\_Snohomish County.pdf

05 118964 RK	R-5	Rural-5 Acre	SFR-Basic
05 121262 RK	R-5	Rural-5 Acre	Single Family Res-Combo
04 115289 RK	R-5	Rural-5 Acre	Single Family Res-Combo
05 117717 RK	R-5	Rural-5 Acre	Single Family Res-Combo
05 116058 RK	R-5	Rural-5 Acre	Single Family Res-Combo
05 121177 RK	R-5	Rural-5 Acre	Single Family Res-Combo
05 125694 MH	R-5	Rural-5 Acre	Double Wide
02 109928 000 01 MH	R-5	Rural-5 Acre	Double Wide
04 113552 RK	R-5	Rural-5 Acre	Single Family Res-Combo
05 101135 MH	R-5	Rural-5 Acre	Triple Wide
05 122201 RK	R-5	Rural-5 Acre	SFR-Basic
05 124820 RK	R-5	Rural-5 Acre	Single Family Res-Combo
05 116959 RK	R-5	Rural-5 Acre	Single Family Res-Combo
04 116406 RK	R-5	Rural-5 Acre	Single Family Res-Combo
02 109925 000 01 MH	R-5	Rural-5 Acre	Double Wide
03 105212 000 01 RK	R-5	Rural-5 Acre	Single Family Res-Combo
04 121450 RK	R-5	Rural-5 Acre	Single Family Res-Combo
05 101421 RK	R-5	Rural-5 Acre	Single Family Res-Combo
05 125665 RK	R-5	Rural-5 Acre	Single Family Res-Combo
04 121457 RK	R-9,600	Residential 9,600 sq. ft.	Single Family Res-Combo
05 120096 RK	R-5	Rural-5 Acre	Single Family Res-Combo
05 120955 RK	RRT-10	Rural Resource Transition-1	Single Family Res-Combo
05 123567 RK	RRT-10	Rural Resource Transition-1	Single Family Res-Combo
05 122813 RK	RRT-10	Rural Resource Transition-1	SFR-Basic
05 100554 RK	RD	Rural Diversification	Single Family Res-Combo
04 111952 001 00 RK	RRT-10	Rural Resource Transition-1	Single Family Res-Combo
05 122185 RK	R-5	Rural-5 Acre	Single Family Res-Combo
05 121908 RK	R-5	Rural-5 Acre	SFR-Basic
05 117251 RK	R-5	Rural-5 Acre	Single Family Res-Combo
05 126008 RK	R-7,200	Residential 7,200 sq. ft.	Single Family Res-Combo
05 121465 RK	R-5	Rural-5 Acre	Single Family Res-Combo
05 124126 RK	R-5	Rural-5 Acre	Single Family Res-Combo
04 120210 RK	R-5	Rural-5 Acre	Single Family Res-Combo
05 117275 RK	R-5	Rural-5 Acre	Single Family Res-Combo
04 121248 RK	R-5	Rural-5 Acre	SFR-Basic
05 121176 RK	CITY	City	SFR-Basic
05 117817 RK	CITY	City	SFR-Basic
05 101257 RK	CITY	City	SFR-Basic
05 101260 RK	CITY	City	SFR-Basic
05 100731 RK	CITY	City	SFR-Basic
05 100618 RK	CITY	City	SFR-Basic
05 100189 RK	CITY	City	SFR-Basic
05 100616 RK	CITY	City	SFR-Basic
04 121721 RK	CITY	City	SFR-Basic
04 121724 RK	CITY	City	SFR-Basic
04 121722 RK	CITY	City	SFR-Basic
04 121725 RK	CITY	City	SFR-Basic

Accessory Dwelling Units

Index # - File Name: 1.0022 - Single Family Dwellings Data\_Snohomish County.pdf

05 100190 RK	CITY	City	Single Family Res-Combo
04 121726 RK	CITY	City	SFR-Basic
05 100183 RK	CITY	City	SFR-Basic
04 121729 RK	CITY	City	SFR-Basic
05 100906 RK	CITY	City	SFR-Basic
05 100718 RK	CITY	City	SFR-Basic
04 121735 RK	CITY	City	SFR-Basic
05 100187 RK	CITY	City	SFR-Basic
05 120019 RK	CITY	City	SFR-Basic
05 100907 RK	CITY	City	SFR-Basic
05 100720 RK	CITY	City	SFR-Basic
05 118786 RK	CITY	City	SFR-Basic
04 121741 RK	CITY	City	SFR-Basic
05 100621 RK	CITY	City	SFR-Basic
04 121442 RK	R-5	Rural-5 Acre	Single Family Res-Combo
05 117695 RK	R-9,600	Residential 9,600 sq. ft.	SFR-Basic
05 117696 RK	R-9,600	Residential 9,600 sq. ft.	SFR-Basic
05 118721 RK	R-9,600	Residential 9,600 sq. ft.	SFR-Basic
05 117702 RK	R-9,600	Residential 9,600 sq. ft.	SFR-Basic
05 117691 RK	R-9,600	Residential 9,600 sq. ft.	SFR-Basic
05 117689 RK	R-9,600	Residential 9,600 sq. ft.	SFR-Basic
05 101047 RK	R-9,600	Residential 9,600 sq. ft.	SFR-Basic
05 117694 RK	R-9,600	Residential 9,600 sq. ft.	SFR-Basic
05 117701 RK	R-9,600	Residential 9,600 sq. ft.	SFR-Basic
05 117700 RK	R-9,600	Residential 9,600 sq. ft.	SFR-Basic
05 101049 RK	R-9,600	Residential 9,600 sq. ft.	SFR-Basic
04 121448 RK	R-5	Rural-5 Acre	Single Family Res-Combo
05 101527 RK	R-5	Rural-5 Acre	Single Family Res-Combo
05 100772 MH	R-5	Rural-5 Acre	Double Wide
05 117688 RK	R-5	Rural-5 Acre	Single Family Res-Combo
05 125969 RK	R-5	Rural-5 Acre	SFR-Basic
05 125387 RK	LDMR	Low Density Multiple Reside	SFR-Basic
05 125388 RK	LDMR	Low Density Multiple Reside	SFR-Basic
05 124695 RK	LDMR	Low Density Multiple Reside	SFR-Basic
04 120846 RK	R-5	Rural-5 Acre	Single Family Res-Combo
05 125968 RK	R-5	Rural-5 Acre	SFR-Basic
04 121015 RK			Single Family Res-Combo
04 121579 RK	F : RC	Forestry : Rural Conservatio	Single Family Res-Combo
05 116367 RK	R-7,200	Residential 7,200 sq. ft.	SFR-Basic
05 123565 RK	F	Forestry	Single Family Res-Combo
05 116331 RK	R-5	Rural-5 Acre	Single Family Res-Combo
05 125955 RK	R-7,200	Residential 7,200 sq. ft.	SFR-Basic
05 127800 RK	R-7,200	Residential 7,200 sq. ft.	SFR-Basic
05 127798 RK	R-7,200	Residential 7,200 sq. ft.	SFR-Basic
05 127860 RK	R-7,200	Residential 7,200 sq. ft.	SFR-Basic
05 117525 RK	R-7,200	Residential 7,200 sq. ft.	SFR-Basic
05 123214 RK	R-7,200	Residential 7,200 sq. ft.	SFR-Basic

Accessory Dwelling Units

Index # - File Name: 1.0022 - Single Family Dwellings Data\_Snohomish County.pdf

05 124118 RK	R-7,200	Residential 7,200 sq. ft.	SFR-Basic
05 119817 RK	R-7,200	Residential 7,200 sq. ft.	SFR-Basic
05 127325 RK	R-7,200	Residential 7,200 sq. ft.	SFR-Basic
05 125176 RK	R-7,200	Residential 7,200 sq. ft.	SFR-Basic
05 100237 RK	R-7,200	Residential 7,200 sq. ft.	Single Family Res-Combo
05 119567 RK	R-7,200	Residential 7,200 sq. ft.	SFR-Basic
05 116368 RK	R-7,200	Residential 7,200 sq. ft.	SFR-Basic
05 116366 RK	R-7,200	Residential 7,200 sq. ft.	SFR-Basic
05 127108 RK	R-7,200	Residential 7,200 sq. ft.	SFR-Basic
05 101056 RK	R-5	Rural-5 Acre	SFR-Basic
05 101057 RK	R-5	Rural-5 Acre	SFR-Basic
05 101059 RK	R-5	Rural-5 Acre	SFR-Basic
05 118622 RK	R-5	Rural-5 Acre	SFR-Basic
05 101060 RK	R-5	Rural-5 Acre	SFR-Basic
05 101062 RK	R-5	Rural-5 Acre	SFR-Basic
05 118628 RK	R-5	Rural-5 Acre	SFR-Basic
05 101661 RK	R-5	Rural-5 Acre	SFR-Basic
05 118629 RK	R-5	Rural-5 Acre	SFR-Basic
05 101663 RK	R-5	Rural-5 Acre	SFR-Basic
05 118623 RK	R-5	Rural-5 Acre	SFR-Basic
05 118631 RK	R-5	Rural-5 Acre	SFR-Basic
05 100876 RK	MR	Multiple Residential	Single Family Res-Combo
05 122846 RK	CITY	City	SFR-Basic
05 122847 RK	CITY	City	SFR-Basic
05 122849 RK	CITY	City	SFR-Basic
05 122850 RK	CITY	City	SFR-Basic
05 122851 RK	CITY	City	SFR-Basic
05 122852 RK	CITY	City	SFR-Basic
05 122853 RK	CITY	City	SFR-Basic
05 122854 RK	CITY	City	SFR-Basic
05 122855 RK	CITY	City	SFR-Basic
05 122856 RK	CITY	City	SFR-Basic
05 122857 RK	CITY	City	SFR-Basic
05 122858 RK	CITY	City	SFR-Basic
05 122859 RK	CITY	City	SFR-Basic
05 122860 RK	CITY	City	SFR-Basic
05 122861 RK	CITY	City	SFR-Basic
04 121727 RK	CITY	City	SFR-Basic
04 121736 RK	CITY	City	SFR-Basic
04 121737 RK	CITY	City	SFR-Basic
04 121738 RK	CITY	City	SFR-Basic
04 121739 RK	CITY	City	SFR-Basic
04 121740 RK	CITY	City	SFR-Basic
04 121742 RK	CITY	City	SFR-Basic
04 121743 RK	CITY	City	SFR-Basic
04 121730 RK	CITY	City	SFR-Basic
04 121731 RK	CITY	City	SFR-Basic

Accessory Dwelling Units

Index # - File Name: 1.0022 - Single Family Dwellings Data\_Snohomish County.pdf

04 121732 RK	CITY	City	SFR-Basic
04 121728 RK	CITY	City	SFR-Basic
04 121733 RK	CITY	City	SFR-Basic
04 121734 RK	CITY	City	SFR-Basic
05 117900 RK	CITY	City	SFR-Basic
05 117902 RK	CITY	City	SFR-Basic
05 117904 RK	CITY	City	SFR-Basic
05 117905 RK	CITY	City	SFR-Basic
05 117906 RK	CITY	City	SFR-Basic
05 117907 RK	CITY	City	SFR-Basic
05 117908 RK	CITY	City	SFR-Basic
05 117909 RK	CITY	City	SFR-Basic
05 117910 RK	CITY	City	SFR-Basic
05 117911 RK	CITY	City	SFR-Basic
05 117912 RK	CITY	City	SFR-Basic
05 117913 RK	CITY	City	SFR-Basic
05 117914 RK	CITY	City	SFR-Basic
05 116436 RK	CITY	City	SFR-Basic
05 122105 RK	CITY	City	SFR-Basic
05 122107 RK	CITY	City	SFR-Basic
05 122865 RK	CITY	City	SFR-Basic
05 122110 RK	CITY	City	SFR-Basic
05 122111 RK	CITY	City	SFR-Basic
05 122113 RK	CITY	City	SFR-Basic
05 122114 RK	CITY	City	SFR-Basic
05 122115 RK	CITY	City	SFR-Basic
05 122117 RK	CITY	City	SFR-Basic
05 122118 RK	CITY	City	SFR-Basic
05 122120 RK	CITY	City	SFR-Basic
05 122121 RK	CITY	City	SFR-Basic
05 122123 RK	CITY	City	SFR-Basic
05 116194 RK	CITY	City	SFR-Basic
05 117843 RK	CITY	City	SFR-Basic
05 100641 RK	CITY	City	SFR-Basic
05 100635 RK	CITY	City	SFR-Basic
05 118247 RK	CITY	City	SFR-Basic
05 117844 RK	CITY	City	SFR-Basic
05 117845 RK	CITY	City	SFR-Basic
05 100633 RK	CITY	City	SFR-Basic
05 100631 RK	CITY	City	SFR-Basic
05 100639 RK	CITY	City	SFR-Basic
05 101031 RK	CITY	City	SFR-Basic
04 121775 RK	RRT-10	Rural Resource Transition-1	SFR-Basic
04 121778 RK	RRT-10	Rural Resource Transition-1	SFR-Basic
04 121779 RK	RRT-10	Rural Resource Transition-1	SFR-Basic
04 121781 RK	RRT-10	Rural Resource Transition-1	SFR-Basic
05 117553 RK	RRT-10	Rural Resource Transition-1	SFR-Basic

Accessory Dwelling Units

Index # - File Name: 1.0022 - Single Family Dwellings Data\_Snohomish County.pdf

04 121783 RK	RRT-10	Rural Resource Transition-1(SFR-Basic	
04 121299 RK	RRT-10	Rural Resource Transition-1(SFR-Basic	
04 121303 RK	RRT-10	Rural Resource Transition-1(SFR-Basic	
04 121300 RK	RRT-10	Rural Resource Transition-1(SFR-Basic	
05 116232 RK	R-5	Rural-5 Acre	SFR-Basic
05 118066 RK	R-5	Rural-5 Acre	SFR-Basic
05 118068 RK	R-5	Rural-5 Acre	SFR-Basic
05 118067 RK	R-5	Rural-5 Acre	SFR-Basic
05 116233 RK	R-5	Rural-5 Acre	SFR-Basic
05 124697 RK	LDMR	Low Density Multiple Reside	SFR-Basic
05 124703 RK	LDMR	Low Density Multiple Reside	SFR-Basic
05 124699 RK	LDMR	Low Density Multiple Reside	SFR-Basic
05 124702 RK	LDMR	Low Density Multiple Reside	SFR-Basic
05 124704 RK	LDMR	Low Density Multiple Reside	SFR-Basic
05 124701 RK	LDMR	Low Density Multiple Reside	SFR-Basic
05 125389 RK	LDMR	Low Density Multiple Reside	SFR-Basic
05 125979 RK	LDMR	Low Density Multiple Reside	SFR-Basic
05 124969 RK	LDMR	Low Density Multiple Reside	SFR-Basic
05 124968 RK	LDMR	Low Density Multiple Reside	SFR-Basic
05 125980 RK	LDMR	Low Density Multiple Reside	SFR-Basic
05 124967 RK	LDMR	Low Density Multiple Reside	SFR-Basic
05 125386 RK	LDMR	Low Density Multiple Reside	SFR-Basic
05 127830 RK	LDMR	Low Density Multiple Reside	SFR-Basic
05 128863 RK	LDMR	Low Density Multiple Reside	SFR-Basic
05 118660 RK	R-7,200	Residential 7,200 sq. ft.	Single Family Res-Combo
05 101316 RK	R-7,200	Residential 7,200 sq. ft.	SFR-Basic
05 100930 RK	R-7,200	Residential 7,200 sq. ft.	SFR-Basic
05 126302 RK	R-7,200	Residential 7,200 sq. ft.	SFR-Basic
05 101317 RK	R-7,200	Residential 7,200 sq. ft.	SFR-Basic
04 120611 RK	R-7,200	Residential 7,200 sq. ft.	SFR-Basic
05 100890 RK	R-7,200	Residential 7,200 sq. ft.	SFR-Basic
05 101631 RK	R-7,200	Residential 7,200 sq. ft.	SFR-Basic
05 101310 RK	R-7,200	Residential 7,200 sq. ft.	SFR-Basic
05 116443 RK	R-5	Rural-5 Acre	SFR-Basic
05 100813 RK	R-7,200	Residential 7,200 sq. ft.	SFR-Basic
05 116266 MH	R-5	Rural-5 Acre	Triple Wide
05 100167 RK	R-7,200	Residential 7,200 sq. ft.	SFR-Basic
05 117043 RK	R-7,200	Residential 7,200 sq. ft.	SFR-Basic
05 117261 RK	R-7,200	Residential 7,200 sq. ft.	SFR-Basic
05 118177 RK	R-7,200	Residential 7,200 sq. ft.	SFR-Basic
05 118714 RK	R-7,200	Residential 7,200 sq. ft.	SFR-Basic
05 118475 RK	R-7,200	Residential 7,200 sq. ft.	SFR-Basic
05 118477 RK	R-7,200	Residential 7,200 sq. ft.	SFR-Basic
05 118715 RK	R-7,200	Residential 7,200 sq. ft.	SFR-Basic
05 118479 RK	R-7,200	Residential 7,200 sq. ft.	SFR-Basic
05 118482 RK	R-7,200	Residential 7,200 sq. ft.	SFR-Basic
05 118484 RK	R-7,200	Residential 7,200 sq. ft.	SFR-Basic

Accessory Dwelling Units

Index # - File Name: 1.0022 - Single Family Dwellings Data\_Snohomish County.pdf

05 118487 RK	R-7,200	Residential 7,200 sq. ft.	SFR-Basic
05 124679 RK	R-7,200	Residential 7,200 sq. ft.	SFR-Basic
05 125011 RK	R-7,200	Residential 7,200 sq. ft.	SFR-Basic
05 124936 RK	R-7,200	Residential 7,200 sq. ft.	SFR-Basic
05 125013 RK	R-7,200	Residential 7,200 sq. ft.	SFR-Basic
05 125161 RK	R-7,200	Residential 7,200 sq. ft.	SFR-Basic
05 125162 RK	R-7,200	Residential 7,200 sq. ft.	SFR-Basic
05 125163 RK	R-7,200	Residential 7,200 sq. ft.	SFR-Basic
05 128967 RK	R-7,200	Residential 7,200 sq. ft.	SFR-Basic
05 125375 RK	R-7,200	Residential 7,200 sq. ft.	SFR-Basic
05 125373 RK	R-7,200	Residential 7,200 sq. ft.	SFR-Basic
05 125380 RK	R-7,200	Residential 7,200 sq. ft.	SFR-Basic
05 126303 RK	R-7,200	Residential 7,200 sq. ft.	SFR-Basic
05 128717 RK	R-7,200	Residential 7,200 sq. ft.	SFR-Basic
05 128708 RK	R-7,200	Residential 7,200 sq. ft.	SFR-Basic
05 128969 RK	R-7,200	Residential 7,200 sq. ft.	SFR-Basic
05 129337 RK	R-7,200	Residential 7,200 sq. ft.	SFR-Basic
05 129064 RK	R-7,200	Residential 7,200 sq. ft.	SFR-Basic
05 129062 RK	R-7,200	Residential 7,200 sq. ft.	SFR-Basic
05 129067 RK	R-7,200	Residential 7,200 sq. ft.	SFR-Basic
05 129075 RK	R-7,200	Residential 7,200 sq. ft.	SFR-Basic
05 129081 RK	R-7,200	Residential 7,200 sq. ft.	SFR-Basic
05 129065 RK	R-7,200	Residential 7,200 sq. ft.	SFR-Basic
05 129066 RK	R-7,200	Residential 7,200 sq. ft.	SFR-Basic
05 128707 RK	R-7,200	Residential 7,200 sq. ft.	SFR-Basic
05 129341 RK	R-7,200	Residential 7,200 sq. ft.	SFR-Basic
05 128706 RK	R-7,200	Residential 7,200 sq. ft.	SFR-Basic
05 128716 RK	R-7,200	Residential 7,200 sq. ft.	SFR-Basic
05 126052 RK	R-7,200	Residential 7,200 sq. ft.	SFR-Basic
05 125376 RK	R-7,200	Residential 7,200 sq. ft.	SFR-Basic
05 125381 RK	R-7,200	Residential 7,200 sq. ft.	SFR-Basic
05 125374 RK	R-7,200	Residential 7,200 sq. ft.	SFR-Basic
05 125164 RK	R-7,200	Residential 7,200 sq. ft.	SFR-Basic
05 117044 RK	R-7,200	Residential 7,200 sq. ft.	SFR-Basic
05 118388 RK	R-7,200	Residential 7,200 sq. ft.	SFR-Basic
05 118390 RK	R-7,200	Residential 7,200 sq. ft.	SFR-Basic
05 118387 RK	R-7,200	Residential 7,200 sq. ft.	SFR-Basic
05 118178 RK	R-7,200	Residential 7,200 sq. ft.	SFR-Basic
05 118179 RK	R-7,200	Residential 7,200 sq. ft.	SFR-Basic
05 118180 RK	R-7,200	Residential 7,200 sq. ft.	SFR-Basic
05 118181 RK	R-7,200	Residential 7,200 sq. ft.	SFR-Basic
05 118389 RK	R-7,200	Residential 7,200 sq. ft.	SFR-Basic
05 100926 RK	R-7,200	Residential 7,200 sq. ft.	SFR-Basic
05 101024 RK	R-7,200	Residential 7,200 sq. ft.	SFR-Basic
05 117875 RK	R-7,200	Residential 7,200 sq. ft.	SFR-Basic
05 101025 RK	R-7,200	Residential 7,200 sq. ft.	SFR-Basic
05 100927 RK	R-7,200	Residential 7,200 sq. ft.	SFR-Basic



Accessory Dwelling Units

Index # - File Name: 1.0022 - Single Family Dwellings Data\_Snohomish County.pdf

05 101093 RK	R-7,200	Residential 7,200 sq. ft.	SFR-Basic
05 101312 RK	R-7,200	Residential 7,200 sq. ft.	SFR-Basic
05 101097 RK	R-7,200	Residential 7,200 sq. ft.	SFR-Basic
05 100928 RK	R-7,200	Residential 7,200 sq. ft.	SFR-Basic
05 101098 RK	R-7,200	Residential 7,200 sq. ft.	SFR-Basic
05 101099 RK	R-7,200	Residential 7,200 sq. ft.	SFR-Basic
05 101100 RK	R-7,200	Residential 7,200 sq. ft.	SFR-Basic
05 100929 RK	R-7,200	Residential 7,200 sq. ft.	SFR-Basic
05 101133 RK	R-7,200	Residential 7,200 sq. ft.	SFR-Basic
05 101101 RK	R-7,200	Residential 7,200 sq. ft.	SFR-Basic
04 120265 MH	R-5	Rural-5 Acre	Double Wide
05 100373 RK	R-7,200	Residential 7,200 sq. ft.	SFR-Basic
05 100374 RK	R-7,200	Residential 7,200 sq. ft.	SFR-Basic
05 100698 RK	R-7,200	Residential 7,200 sq. ft.	SFR-Basic
05 100700 RK	R-7,200	Residential 7,200 sq. ft.	SFR-Basic
05 100701 RK	R-7,200	Residential 7,200 sq. ft.	SFR-Basic
05 100375 RK	R-7,200	Residential 7,200 sq. ft.	SFR-Basic
05 101627 RK	R-7,200	Residential 7,200 sq. ft.	SFR-Basic
05 100376 RK	R-7,200	Residential 7,200 sq. ft.	SFR-Basic
05 101067 RK	R-7,200	Residential 7,200 sq. ft.	SFR-Basic
04 121471 RK	R-7,200	Residential 7,200 sq. ft.	Single Family Res-Combo
05 118600 RK	R-7,200	Residential 7,200 sq. ft.	SFR-Basic
04 120703 RK	R-7,200	Residential 7,200 sq. ft.	Single Family Res-Combo
04 120327 RK	R-7,200	Residential 7,200 sq. ft.	Single Family Res-Combo
05 101068 RK	R-7,200	Residential 7,200 sq. ft.	SFR-Basic
05 101213 RK	R-7,200	Residential 7,200 sq. ft.	Single Family Res-Combo
05 100191 RK	R-7,200	Residential 7,200 sq. ft.	Single Family Res-Combo
05 100202 RK	R-7,200	Residential 7,200 sq. ft.	Single Family Res-Combo
05 117340 RK	R-7,200	Residential 7,200 sq. ft.	SFR-Basic
05 118593 RK	R-7,200	Residential 7,200 sq. ft.	SFR-Basic
05 118597 RK	R-7,200	Residential 7,200 sq. ft.	SFR-Basic
05 118598 RK	R-7,200	Residential 7,200 sq. ft.	SFR-Basic
05 117337 RK	R-7,200	Residential 7,200 sq. ft.	SFR-Basic
05 117339 RK	R-7,200	Residential 7,200 sq. ft.	SFR-Basic
04 120079 RK	WFB	Waterfront Beach	Single Family Res-Combo
05 101410 RK	R-7,200	Residential 7,200 sq. ft.	SFR-Basic
05 101414 RK	R-7,200	Residential 7,200 sq. ft.	SFR-Basic
05 101412 RK	R-7,200	Residential 7,200 sq. ft.	SFR-Basic
05 100165 RK	R-7,200	Residential 7,200 sq. ft.	SFR-Basic
05 101413 RK	R-7,200	Residential 7,200 sq. ft.	SFR-Basic
05 101415 RK	R-7,200	Residential 7,200 sq. ft.	SFR-Basic
05 121056 RK	R-7,200	Residential 7,200 sq. ft.	SFR-Basic
05 121054 RK	R-7,200	Residential 7,200 sq. ft.	SFR-Basic
05 123030 RK	R-7,200	Residential 7,200 sq. ft.	SFR-Basic
04 121769 RK	R-7,200	Residential 7,200 sq. ft.	SFR-Basic
05 119951 RK	R-7,200	Residential 7,200 sq. ft.	SFR-Basic
05 123630 RK	R-7,200	Residential 7,200 sq. ft.	SFR-Basic

Accessory Dwelling Units

Index # - File Name: 1.0022 - Single Family Dwellings Data\_Snohomish County.pdf

04 121759 RK	R-7,200	Residential 7,200 sq. ft.	SFR-Basic
04 121750 RK	R-7,200	Residential 7,200 sq. ft.	SFR-Basic
05 101023 RK	R-7,200	Residential 7,200 sq. ft.	SFR-Basic
05 119856 RK	R-7,200	Residential 7,200 sq. ft.	SFR-Basic
05 128970 RK	R-7,200	Residential 7,200 sq. ft.	SFR-Basic
04 121756 RK	R-7,200	Residential 7,200 sq. ft.	SFR-Basic
05 116602 RK	R-5	Rural-5 Acre	Single Family Res-Combo
05 126036 RK	R-7,200	Residential 7,200 sq. ft.	SFR-Basic
05 129342 RK	R-7,200	Residential 7,200 sq. ft.	SFR-Basic
05 122864 RK	R-7,200	Residential 7,200 sq. ft.	SFR-Basic
05 125729 RK	R-7,200	Residential 7,200 sq. ft.	SFR-Basic
05 125166 RK	R-7,200	Residential 7,200 sq. ft.	SFR-Basic
05 122869 RK	R-7,200	Residential 7,200 sq. ft.	SFR-Basic
05 122867 RK	R-7,200	Residential 7,200 sq. ft.	SFR-Basic
05 122872 RK	R-7,200	Residential 7,200 sq. ft.	SFR-Basic
05 123035 RK	R-7,200	Residential 7,200 sq. ft.	SFR-Basic
05 126037 RK	R-7,200	Residential 7,200 sq. ft.	SFR-Basic
05 122873 RK	R-7,200	Residential 7,200 sq. ft.	SFR-Basic
04 121597 RK	R-7,200	Residential 7,200 sq. ft.	SFR-Basic
05 119859 RK	R-7,200	Residential 7,200 sq. ft.	SFR-Basic
04 121767 RK	R-7,200	Residential 7,200 sq. ft.	SFR-Basic
04 121452 RK	R-7,200	Residential 7,200 sq. ft.	SFR-Basic
04 121766 RK	R-7,200	Residential 7,200 sq. ft.	SFR-Basic
05 119949 RK	R-7,200	Residential 7,200 sq. ft.	SFR-Basic
05 119858 RK	R-7,200	Residential 7,200 sq. ft.	SFR-Basic
04 121308 RK	R-7,200	Residential 7,200 sq. ft.	SFR-Basic
04 121453 RK	R-7,200	Residential 7,200 sq. ft.	SFR-Basic
04 121309 RK	R-7,200	Residential 7,200 sq. ft.	SFR-Basic
04 121598 RK	R-7,200	Residential 7,200 sq. ft.	SFR-Basic
05 117872 RK	R-7,200	Residential 7,200 sq. ft.	SFR-Basic
05 122863 RK	R-7,200	Residential 7,200 sq. ft.	SFR-Basic
04 121751 RK	R-7,200	Residential 7,200 sq. ft.	SFR-Basic
05 125165 RK	R-7,200	Residential 7,200 sq. ft.	SFR-Basic
05 126034 RK	R-7,200	Residential 7,200 sq. ft.	SFR-Basic
05 123270 RK	R-7,200	Residential 7,200 sq. ft.	SFR-Basic
05 123634 RK	R-7,200	Residential 7,200 sq. ft.	SFR-Basic
05 125730 RK	R-7,200	Residential 7,200 sq. ft.	SFR-Basic
05 123272 RK	R-7,200	Residential 7,200 sq. ft.	SFR-Basic
05 123274 RK	R-7,200	Residential 7,200 sq. ft.	SFR-Basic
05 126038 RK	R-7,200	Residential 7,200 sq. ft.	SFR-Basic
05 123273 RK	R-7,200	Residential 7,200 sq. ft.	SFR-Basic
05 123102 RK	R-7,200	Residential 7,200 sq. ft.	SFR-Basic
04 121600 RK	R-7,200	Residential 7,200 sq. ft.	SFR-Basic
04 121746 RK	R-7,200	Residential 7,200 sq. ft.	SFR-Basic
04 121747 RK	R-7,200	Residential 7,200 sq. ft.	SFR-Basic
05 123031 RK	R-7,200	Residential 7,200 sq. ft.	SFR-Basic
04 121754 RK	R-7,200	Residential 7,200 sq. ft.	SFR-Basic

Accessory Dwelling Units

Index # - File Name: 1.0022 - Single Family Dwellings Data\_Snohomish County.pdf

05 119852 RK	R-7,200	Residential 7,200 sq. ft.	SFR-Basic
04 121511 RK	R-7,200	Residential 7,200 sq. ft.	SFR-Basic
05 117262 RK	R-7,200	Residential 7,200 sq. ft.	SFR-Basic
05 122874 RK	R-7,200	Residential 7,200 sq. ft.	SFR-Basic
05 123034 RK	R-7,200	Residential 7,200 sq. ft.	SFR-Basic
05 122876 RK	R-7,200	Residential 7,200 sq. ft.	SFR-Basic
05 123633 RK	R-7,200	Residential 7,200 sq. ft.	SFR-Basic
04 119598 RK	CITY	City	Duplex-Combo
05 122227 RK	R-9,600(PRD)	Residential 9,600 sq. ft.	SFR-Basic
05 122228 RK	R-9,600(PRD)	Residential 9,600 sq. ft.	SFR-Basic
05 122229 RK	R-9,600(PRD)	Residential 9,600 sq. ft.	SFR-Basic
05 122762 RK	R-9,600(PRD)	Residential 9,600 sq. ft.	SFR-Basic
05 122763 RK	R-9,600(PRD)	Residential 9,600 sq. ft.	SFR-Basic
05 126536 RK	R-9,600(PRD)	Residential 9,600 sq. ft.	SFR-Basic
05 126532 RK	R-9,600(PRD)	Residential 9,600 sq. ft.	SFR-Basic
05 128148 RK	R-9,600(PRD)	Residential 9,600 sq. ft.	SFR-Basic
05 129047 RK	R-9,600(PRD)	Residential 9,600 sq. ft.	SFR-Basic
05 128151 RK	R-9,600(PRD)	Residential 9,600 sq. ft.	SFR-Basic
05 129048 RK	R-9,600(PRD)	Residential 9,600 sq. ft.	SFR-Basic
05 129053 RK	R-9,600(PRD)	Residential 9,600 sq. ft.	SFR-Basic
05 100754 RK	PRD-9,600	Residential 9,600 sq. ft.	SFR-Basic
05 101300 RK	R-7,200	Residential 7,200 sq. ft.	SFR-Basic
05 118938 RK	R-9,600	Residential 9,600 sq. ft.	Duplex-Combo
05 120064 RK	R-9,600	Residential 9,600 sq. ft.	Duplex-Combo
04 121104 RK	R-9,600	Residential 9,600 sq. ft.	Single Family Res-Combo
05 102044 RK	R-5	Rural-5 Acre	Single Family Res-Combo
05 102038 RK	R-5	Rural-5 Acre	Single Family Res-Combo
05 118811 RK	CITY	City	SFR-Basic
05 118009 RK	CITY	City	SFR-Basic
05 119992 RK	CITY	City	SFR-Basic
05 124940 RK	CITY	City	SFR-Basic
05 100697 RK	CITY	City	SFR-Basic
05 124946 RK	CITY	City	SFR-Basic
05 128154 RK	CITY	City	SFR-Basic
05 128880 RK	CITY	City	SFR-Basic
05 116246 RK	R-9,600(PRD)	Residential 9,600 sq. ft.	SFR-Basic
05 101108 RK	R-9,600(PRD)	Residential 9,600 sq. ft.	SFR-Basic
05 101234 RK	R-9,600(PRD)	Residential 9,600 sq. ft.	SFR-Basic
05 116245 RK	R-9,600(PRD)	Residential 9,600 sq. ft.	SFR-Basic
05 116247 RK	R-9,600(PRD)	Residential 9,600 sq. ft.	SFR-Basic
05 116248 RK	R-9,600(PRD)	Residential 9,600 sq. ft.	SFR-Basic
05 116965 RK	R-9,600(PRD)	Residential 9,600 sq. ft.	SFR-Basic
05 120124 RK	R-9,600(PRD)	Residential 9,600 sq. ft.	SFR-Basic
05 116244 RK	R-9,600(PRD)	Residential 9,600 sq. ft.	SFR-Basic
05 121501 RK	R-9,600(PRD)	Residential 9,600 sq. ft.	SFR-Basic
05 126021 RK	R-9,600(PRD)	Residential 9,600 sq. ft.	SFR-Basic
05 120125 RK	R-9,600(PRD)	Residential 9,600 sq. ft.	SFR-Basic

Accessory Dwelling Units

Index # - File Name: 1.0022 - Single Family Dwellings Data\_Snohomish County.pdf

05 121495 RK	R-9,600(PRD)	Residential 9,600 sq. ft.	SFR-Basic
05 120121 RK	R-9,600(PRD)	Residential 9,600 sq. ft.	SFR-Basic
05 116781 RK	R-9,600(PRD)	Residential 9,600 sq. ft.	SFR-Basic
05 116782 RK	R-9,600(PRD)	Residential 9,600 sq. ft.	SFR-Basic
05 126023 RK	R-9,600(PRD)	Residential 9,600 sq. ft.	SFR-Basic
05 118316 RK	R-9,600(PRD)	Residential 9,600 sq. ft.	SFR-Basic
05 124266 RK	R-9,600(PRD)	Residential 9,600 sq. ft.	SFR-Basic
05 120351 RK	R-9,600(PRD)	Residential 9,600 sq. ft.	SFR-Basic
05 120352 RK	R-9,600(PRD)	Residential 9,600 sq. ft.	SFR-Basic
05 120354 RK	R-9,600(PRD)	Residential 9,600 sq. ft.	SFR-Basic
05 120356 RK	R-9,600(PRD)	Residential 9,600 sq. ft.	SFR-Basic
05 120357 RK	R-9,600(PRD)	Residential 9,600 sq. ft.	SFR-Basic
05 120358 RK	R-9,600(PRD)	Residential 9,600 sq. ft.	SFR-Basic
05 120359 RK	R-9,600(PRD)	Residential 9,600 sq. ft.	SFR-Basic
05 120360 RK	R-9,600(PRD)	Residential 9,600 sq. ft.	SFR-Basic
05 120361 RK	R-9,600(PRD)	Residential 9,600 sq. ft.	SFR-Basic
05 120362 RK	R-9,600(PRD)	Residential 9,600 sq. ft.	SFR-Basic
05 120363 RK	R-9,600(PRD)	Residential 9,600 sq. ft.	SFR-Basic
05 129049 RK	R-9,600(PRD)	Residential 9,600 sq. ft.	SFR-Basic
05 129051 RK	R-9,600(PRD)	Residential 9,600 sq. ft.	SFR-Basic
05 129054 RK	R-9,600(PRD)	Residential 9,600 sq. ft.	SFR-Basic
05 128150 RK	R-9,600(PRD)	Residential 9,600 sq. ft.	SFR-Basic
05 128149 RK	R-9,600(PRD)	Residential 9,600 sq. ft.	SFR-Basic
05 128155 RK	R-9,600(PRD)	Residential 9,600 sq. ft.	SFR-Basic
05 126024 RK	R-9,600(PRD)	Residential 9,600 sq. ft.	SFR-Basic
05 124473 RK	R-9,600(PRD)	Residential 9,600 sq. ft.	SFR-Basic
05 126025 RK	R-9,600(PRD)	Residential 9,600 sq. ft.	SFR-Basic
05 126534 RK	R-9,600(PRD)	Residential 9,600 sq. ft.	SFR-Basic
05 124472 RK	R-9,600(PRD)	Residential 9,600 sq. ft.	SFR-Basic
05 129050 RK	R-9,600(PRD)	Residential 9,600 sq. ft.	SFR-Basic
05 129055 RK	R-9,600(PRD)	Residential 9,600 sq. ft.	SFR-Basic
05 127357 RK	R-9,600(PRD)	Residential 9,600 sq. ft.	SFR-Basic
05 128153 RK	R-9,600(PRD)	Residential 9,600 sq. ft.	SFR-Basic
05 129052 RK	R-9,600(PRD)	Residential 9,600 sq. ft.	SFR-Basic
05 128152 RK	R-9,600(PRD)	Residential 9,600 sq. ft.	SFR-Basic
05 100884 RK	F	Forestry	Single Family Res-Combo
04 119644 RK	R-5	Rural-5 Acre	SFR-Basic
04 119645 RK	R-5	Rural-5 Acre	SFR-Basic
04 121514 RK	R-7,200	Residential 7,200 sq. ft.	SFR-Basic
04 121757 RK	R-7,200	Residential 7,200 sq. ft.	SFR-Basic
04 121770 RK	R-7,200	Residential 7,200 sq. ft.	SFR-Basic
05 126032 RK	R-7,200	Residential 7,200 sq. ft.	SFR-Basic
05 126033 RK	R-7,200	Residential 7,200 sq. ft.	SFR-Basic
05 120129 RK	R-9,600	Residential 9,600 sq. ft.	SFR-Basic
05 121473 RK	R-9,600	Residential 9,600 sq. ft.	SFR-Basic
05 121476 RK	R-9,600	Residential 9,600 sq. ft.	SFR-Basic
05 121475 RK	R-9,600	Residential 9,600 sq. ft.	SFR-Basic

Accessory Dwelling Units

Index # - File Name: 1.0022 - Single Family Dwellings Data\_Snohomish County.pdf

05 121472 RK	R-9,600	Residential 9,600 sq. ft.	SFR-Basic
05 118643 RK	R-9,600	Residential 9,600 sq. ft.	SFR-Basic
05 118644 RK	R-9,600	Residential 9,600 sq. ft.	SFR-Basic
05 118646 RK	R-9,600	Residential 9,600 sq. ft.	SFR-Basic
05 118647 RK	R-9,600	Residential 9,600 sq. ft.	SFR-Basic
05 120131 RK	R-9,600	Residential 9,600 sq. ft.	SFR-Basic
05 121096 RK	R-9,600	Residential 9,600 sq. ft.	SFR-Basic
05 123323 RK	R-9,600	Residential 9,600 sq. ft.	SFR-Basic
05 123649 RK	R-9,600	Residential 9,600 sq. ft.	SFR-Basic
05 123324 RK	R-9,600	Residential 9,600 sq. ft.	SFR-Basic
05 123648 RK	R-9,600	Residential 9,600 sq. ft.	SFR-Basic
05 124286 RK	R-9,600	Residential 9,600 sq. ft.	SFR-Basic
05 123650 RK	R-9,600	Residential 9,600 sq. ft.	SFR-Basic
05 123654 RK	R-9,600	Residential 9,600 sq. ft.	SFR-Basic
05 125645 RK	R-9,600	Residential 9,600 sq. ft.	SFR-Basic
05 101605 RK	R-9,600	Residential 9,600 sq. ft.	SFR-Basic
05 125650 RK	R-9,600	Residential 9,600 sq. ft.	SFR-Basic
05 121097 RK	R-9,600	Residential 9,600 sq. ft.	SFR-Basic
05 116611 RK	R-9,600	Residential 9,600 sq. ft.	SFR-Basic
05 116612 RK	R-9,600	Residential 9,600 sq. ft.	SFR-Basic
05 101603 RK	R-9,600	Residential 9,600 sq. ft.	SFR-Basic
05 117445 RK	R-9,600	Residential 9,600 sq. ft.	SFR-Basic
05 117444 RK	R-9,600	Residential 9,600 sq. ft.	SFR-Basic
05 118129 RK	R-9,600	Residential 9,600 sq. ft.	SFR-Basic
05 118132 RK	R-9,600	Residential 9,600 sq. ft.	SFR-Basic
05 123652 RK	R-9,600	Residential 9,600 sq. ft.	SFR-Basic
05 123041 RK	R-9,600	Residential 9,600 sq. ft.	SFR-Basic
05 125648 RK	R-9,600	Residential 9,600 sq. ft.	SFR-Basic
05 125646 RK	R-9,600	Residential 9,600 sq. ft.	SFR-Basic
05 125649 RK	R-9,600	Residential 9,600 sq. ft.	SFR-Basic
05 123943 RK	R-5	Rural-5 Acre	Single Family Res-Combo
05 100420 RK	R-9,600	Residential 9,600 sq. ft.	Single Family Res-Combo
05 117054 RK	R-5	Rural-5 Acre	Single Family Res-Combo
05 116820 RK	R-5	Rural-5 Acre	Single Family Res-Combo
05 100661 RK	LDMR	Low Density Multiple Reside	SFR-Basic
05 101163 RK	LDMR	Low Density Multiple Reside	SFR-Basic
05 101166 RK	LDMR	Low Density Multiple Reside	SFR-Basic
05 100663 RK	LDMR	Low Density Multiple Reside	SFR-Basic
05 100957 RK	LDMR	Low Density Multiple Reside	SFR-Basic
05 100953 RK	LDMR	Low Density Multiple Reside	SFR-Basic
05 100958 RK	LDMR : R-7,20	Low Density Multiple Reside	SFR-Basic
05 101168 RK	LDMR	Low Density Multiple Reside	SFR-Basic
05 101170 RK	LDMR	Low Density Multiple Reside	SFR-Basic
05 100664 RK	LDMR	Low Density Multiple Reside	SFR-Basic
05 101171 RK	LDMR	Low Density Multiple Reside	SFR-Basic
05 101174 RK	LDMR	Low Density Multiple Reside	SFR-Basic
05 101160 RK	LDMR	Low Density Multiple Reside	SFR-Basic

Accessory Dwelling Units

Index # - File Name: 1.0022 - Single Family Dwellings Data\_Snohomish County.pdf

05 101175 RK	LDMR	Low Density Multiple Reside	SFR-Basic
05 101176 RK	LDMR	Low Density Multiple Reside	SFR-Basic
05 100955 RK	LDMR	Low Density Multiple Reside	SFR-Basic
05 100954 RK	LDMR	Low Density Multiple Reside	SFR-Basic
05 121104 RK	R-7,200	Residential 7,200 sq. ft.	Single Family Res-Combo
05 121102 RK	R-7,200	Residential 7,200 sq. ft.	Single Family Res-Combo
05 127327 RK	R-7,200	Residential 7,200 sq. ft.	SFR-Basic
05 124894 RK	R-7,200	Residential 7,200 sq. ft.	SFR-Basic
05 120464 RK	R-7,200	Residential 7,200 sq. ft.	Single Family Res-Combo
05 124897 RK	R-7,200	Residential 7,200 sq. ft.	SFR-Basic
05 121109 RK	R-7,200	Residential 7,200 sq. ft.	SFR-Basic
05 125178 RK	R-7,200	Residential 7,200 sq. ft.	Single Family Res-Combo
05 128875 RK	R-7,200	Residential 7,200 sq. ft.	SFR-Basic
05 117706 RK	R-7,200	Residential 7,200 sq. ft.	SFR-Basic
05 101053 RK	R-5	Rural-5 Acre	SFR-Basic
05 118667 RK	MR	Multiple Residential	SFR-Basic
05 100974 RK	R-7,200	Residential 7,200 sq. ft.	SFR-Basic
05 116850 RK	R-7,200	Residential 7,200 sq. ft.	SFR-Basic
05 116856 RK	R-7,200	Residential 7,200 sq. ft.	SFR-Basic
05 121568 RK	R-7,200	Residential 7,200 sq. ft.	Single Family Res-Combo
05 121567 RK	R-7,200	Residential 7,200 sq. ft.	Single Family Res-Combo
05 117567 RK	R-7,200	Residential 7,200 sq. ft.	SFR-Basic
05 119066 RK	R-7,200	Residential 7,200 sq. ft.	SFR-Basic
05 117568 RK	R-7,200	Residential 7,200 sq. ft.	SFR-Basic
05 119064 RK	R-7,200	Residential 7,200 sq. ft.	SFR-Basic
05 121570 RK	R-7,200	Residential 7,200 sq. ft.	Single Family Res-Combo
05 102092 RK	R-7,200	Residential 7,200 sq. ft.	Single Family Res-Combo
05 102095 RK	R-7,200	Residential 7,200 sq. ft.	Single Family Res-Combo
05 102097 RK	R-7,200	Residential 7,200 sq. ft.	Single Family Res-Combo
05 124709 RK	CITY	City	Single Family Res-Combo
05 116084 RK	R-7,200	Residential 7,200 sq. ft.	SFR-Basic
05 101831 RK	R-7,200	Residential 7,200 sq. ft.	SFR-Basic
05 116085 RK	R-7,200	Residential 7,200 sq. ft.	SFR-Basic
05 116086 RK	R-7,200	Residential 7,200 sq. ft.	SFR-Basic
05 116087 RK	R-7,200	Residential 7,200 sq. ft.	SFR-Basic
05 101272 RK	R-7,200	Residential 7,200 sq. ft.	SFR-Basic
05 101273 RK	R-7,200	Residential 7,200 sq. ft.	SFR-Basic
05 101346 RK	R-7,200	Residential 7,200 sq. ft.	SFR-Basic
05 117669 RK	R-7,200	Residential 7,200 sq. ft.	SFR-Basic
05 123678 RK	R-9,600	Residential 9,600 sq. ft.	Single Family Res-Combo
05 100563 RK	R-7,200	Residential 7,200 sq. ft.	Duplex-Combo
05 116381 RK	R-7,200	Residential 7,200 sq. ft.	Single Family Res-Combo
05 116377 RK	R-7,200	Residential 7,200 sq. ft.	Single Family Res-Combo
05 116391 RK	R-7,200	Residential 7,200 sq. ft.	Single Family Res-Combo
05 128006 RK	PRD-20,000	Residential 20,000 sq. ft.	SFR-Basic
05 128810 RK	PRD-20,000	Residential 20,000 sq. ft.	Single Family Res-Combo
05 128005 RK	PRD-20,000	Residential 20,000 sq. ft.	SFR-Basic

Accessory Dwelling Units

Index # - File Name: 1.0022 - Single Family Dwellings Data\_Snohomish County.pdf

05 128001 RK	PRD-20,000	Residential 20,000 sq. ft.	SFR-Basic
05 125228 RK	PRD-20,000	Residential 20,000 sq. ft.	SFR-Basic
05 127363 RK	PRD-20,000	Residential 20,000 sq. ft.	SFR-Basic
05 126845 RK	PRD-20,000	Residential 20,000 sq. ft.	SFR-Basic
05 126341 RK	PRD-20,000	Residential 20,000 sq. ft.	SFR-Basic
05 124324 RK	PRD-20,000	Residential 20,000 sq. ft.	SFR-Basic
05 126783 RK	PRD-20,000	Residential 20,000 sq. ft.	SFR-Basic
05 126849 RK	PRD-20,000	Residential 20,000 sq. ft.	SFR-Basic
05 123444 RK	PRD-20,000	Residential 20,000 sq. ft.	SFR-Basic
05 123691 RK	PRD-20,000	Residential 20,000 sq. ft.	SFR-Basic
05 126517 RK	PRD-20,000	Residential 20,000 sq. ft.	SFR-Basic
05 126118 RK	PRD-20,000	Residential 20,000 sq. ft.	SFR-Basic
05 124790 RK	PRD-20,000	Residential 20,000 sq. ft.	SFR-Basic
05 122918 RK	PRD-20,000	Residential 20,000 sq. ft.	SFR-Basic
05 124327 RK	PRD-20,000	Residential 20,000 sq. ft.	SFR-Basic
05 123448 RK	PRD-20,000	Residential 20,000 sq. ft.	SFR-Basic
05 122381 RK	PRD-20,000	Residential 20,000 sq. ft.	SFR-Basic
05 122382 RK	PRD-20,000	Residential 20,000 sq. ft.	SFR-Basic
05 128004 RK	PRD-20,000	Residential 20,000 sq. ft.	SFR-Basic
05 129006 RK	PRD-20,000	Residential 20,000 sq. ft.	SFR-Basic
05 118652 RK	PRD-20,000	Residential 20,000 sq. ft.	SFR-Basic
05 121181 RK	PRD-20,000	Residential 20,000 sq. ft.	SFR-Basic
05 118043 RK	PRD-20,000	Residential 20,000 sq. ft.	SFR-Basic
05 118648 RK	PRD-20,000	Residential 20,000 sq. ft.	SFR-Basic
05 118031 RK	PRD-20,000	Residential 20,000 sq. ft.	SFR-Basic
05 118044 RK	PRD-20,000	Residential 20,000 sq. ft.	SFR-Basic
05 118653 RK	PRD-20,000	Residential 20,000 sq. ft.	SFR-Basic
05 118035 RK	PRD-20,000	Residential 20,000 sq. ft.	SFR-Basic
05 119884 RK	PRD-20,000	Residential 20,000 sq. ft.	SFR-Basic
05 118028 RK	PRD-20,000	Residential 20,000 sq. ft.	SFR-Basic
05 118032 RK	PRD-20,000	Residential 20,000 sq. ft.	SFR-Basic
05 120860 RK	PRD-20,000	Residential 20,000 sq. ft.	SFR-Basic
05 121409 RK	PRD-20,000	Residential 20,000 sq. ft.	SFR-Basic
05 119885 RK	PRD-20,000	Residential 20,000 sq. ft.	SFR-Basic
05 121686 RK	PRD-20,000	Residential 20,000 sq. ft.	SFR-Basic
05 123450 RK	PRD-20,000	Residential 20,000 sq. ft.	SFR-Basic
05 125534 RK	PRD-20,000	Residential 20,000 sq. ft.	SFR-Basic
05 123193 RK	PRD-20,000	Residential 20,000 sq. ft.	SFR-Basic
05 125229 RK	PRD-20,000	Residential 20,000 sq. ft.	SFR-Basic
05 125535 RK	PRD-20,000	Residential 20,000 sq. ft.	SFR-Basic
05 127361 RK	PRD-20,000	Residential 20,000 sq. ft.	SFR-Basic
05 127367 RK	PRD-20,000	Residential 20,000 sq. ft.	SFR-Basic
05 127364 RK	PRD-20,000	Residential 20,000 sq. ft.	SFR-Basic
05 127362 RK	PRD-20,000	Residential 20,000 sq. ft.	SFR-Basic
05 129007 RK	PRD-20,000	Residential 20,000 sq. ft.	SFR-Basic
05 117014 RK	PRD-20,000	Residential 20,000 sq. ft.	SFR-Basic
05 117015 RK	PRD-20,000	Residential 20,000 sq. ft.	SFR-Basic

Accessory Dwelling Units

Index # - File Name: 1.0022 - Single Family Dwellings Data\_Snohomish County.pdf

05 117017 RK	PRD-20,000	Residential 20,000 sq. ft.	SFR-Basic
05 117018 RK	PRD-20,000	Residential 20,000 sq. ft.	SFR-Basic
05 118657 RK	PRD-20,000	Residential 20,000 sq. ft.	SFR-Basic
05 118055 RK	PRD-20,000	Residential 20,000 sq. ft.	SFR-Basic
05 119886 RK	PRD-20,000	Residential 20,000 sq. ft.	SFR-Basic
05 118026 RK	PRD-20,000	Residential 20,000 sq. ft.	SFR-Basic
05 119245 RK	PRD-20,000	Residential 20,000 sq. ft.	SFR-Basic
05 118025 RK	PRD-20,000	Residential 20,000 sq. ft.	SFR-Basic
05 118654 RK	PRD-20,000	Residential 20,000 sq. ft.	SFR-Basic
05 118017 RK	PRD-20,000	Residential 20,000 sq. ft.	SFR-Basic
05 118656 RK	PRD-20,000	Residential 20,000 sq. ft.	SFR-Basic
05 118050 RK	PRD-20,000	Residential 20,000 sq. ft.	SFR-Basic
05 118051 RK	PRD-20,000	Residential 20,000 sq. ft.	SFR-Basic
05 118052 RK	PRD-20,000	Residential 20,000 sq. ft.	SFR-Basic
05 118049 RK	PRD-20,000	Residential 20,000 sq. ft.	SFR-Basic
05 117019 RK	PRD-20,000	Residential 20,000 sq. ft.	SFR-Basic
05 119244 RK	PRD-20,000	Residential 20,000 sq. ft.	SFR-Basic
05 117021 RK	PRD-20,000	Residential 20,000 sq. ft.	SFR-Basic
05 117022 RK	PRD-20,000	Residential 20,000 sq. ft.	SFR-Basic
05 119243 RK	PRD-20,000	Residential 20,000 sq. ft.	SFR-Basic
05 118045 RK	PRD-20,000	Residential 20,000 sq. ft.	SFR-Basic
05 101547 RK	R-5	Rural-5 Acre	Single Family Res-Combo
05 124415 RK	CITY	City	SFR-Basic
05 101677 RK	F	Forestry	Single Family Res-Combo
05 121271 RK	CITY	City	SFR-Basic
05 121282 RK	CITY	City	SFR-Basic
05 121289 RK	CITY	City	SFR-Basic
05 121288 RK	CITY	City	SFR-Basic
05 121286 RK	CITY	City	SFR-Basic
05 121281 RK	CITY	City	SFR-Basic
05 121269 RK	CITY	City	SFR-Basic
05 121285 RK	CITY	City	SFR-Basic
05 100292 RK	CITY	City	SFR-Basic
04 120933 RK	CITY	City	SFR-Basic
05 100295 RK	CITY	City	SFR-Basic
04 120935 RK	CITY	City	SFR-Basic
05 116337 RK	CITY	City	SFR-Basic
04 120932 RK	CITY	City	SFR-Basic
05 116338 RK	CITY	City	SFR-Basic
05 116925 RK	CITY	City	SFR-Basic
05 100302 RK	CITY	City	SFR-Basic
05 116339 RK	CITY	City	SFR-Basic
05 116926 RK	CITY	City	SFR-Basic
05 100297 RK	CITY	City	SFR-Basic
05 116340 RK	CITY	City	SFR-Basic
04 120930 RK	CITY	City	SFR-Basic
04 120931 RK	CITY	City	SFR-Basic



Accessory Dwelling Units

Index # - File Name: 1.0022 - Single Family Dwellings Data\_Snohomish County.pdf

05 116915 RK	CITY	City	SFR-Basic
05 116918 RK	CITY	City	SFR-Basic
05 116920 RK	CITY	City	SFR-Basic
05 116341 RK	CITY	City	SFR-Basic
05 116921 RK	CITY	City	SFR-Basic
05 116342 RK	CITY	City	SFR-Basic
05 116343 RK	CITY	City	SFR-Basic
05 116344 RK	CITY	City	SFR-Basic
05 100303 RK	CITY	City	SFR-Basic
05 116914 RK	CITY	City	SFR-Basic
05 116927 RK	CITY	City	SFR-Basic
05 116345 RK	CITY	City	SFR-Basic
05 116922 RK	CITY	City	SFR-Basic
05 116346 RK	CITY	City	SFR-Basic
05 116929 RK	CITY	City	SFR-Basic
05 100304 RK	CITY	City	SFR-Basic
05 100299 RK	CITY	City	SFR-Basic
05 116923 RK	CITY	City	SFR-Basic
04 120936 RK	CITY	City	SFR-Basic
05 120201 RK	CITY	City	SFR-Basic
05 118246 RK	CITY	City	SFR-Basic
05 119702 RK	CITY	City	SFR-Basic
05 118256 RK	CITY	City	SFR-Basic
05 120810 RK	CITY	City	SFR-Basic
05 118258 RK	CITY	City	SFR-Basic
05 120808 RK	CITY	City	SFR-Basic
05 120803 RK	CITY	City	SFR-Basic
05 118911 RK	CITY	City	SFR-Basic
05 118235 RK	CITY	City	SFR-Basic
05 120200 RK	CITY	City	SFR-Basic
05 120800 RK	CITY	City	SFR-Basic
05 118254 RK	CITY	City	SFR-Basic
05 120811 RK	CITY	City	SFR-Basic
05 118252 RK	CITY	City	SFR-Basic
05 120801 RK	CITY	City	SFR-Basic
05 119703 RK	CITY	City	SFR-Basic
05 118240 RK	CITY	City	SFR-Basic
05 118243 RK	CITY	City	SFR-Basic
05 118245 RK	CITY	City	SFR-Basic
05 118250 RK	CITY	City	SFR-Basic
05 118241 RK	CITY	City	SFR-Basic
05 118257 RK	CITY	City	SFR-Basic
05 120804 RK	CITY	City	SFR-Basic
05 119696 RK	CITY	City	SFR-Basic
05 118263 RK	CITY	City	SFR-Basic
05 121280 RK	CITY	City	SFR-Basic
05 120805 RK	CITY	City	SFR-Basic

Accessory Dwelling Units

Index # - File Name: 1.0022 - Single Family Dwellings Data\_Snohomish County.pdf

05 121279 RK	CITY	City	SFR-Basic
05 121283 RK	CITY	City	SFR-Basic
05 120809 RK	CITY	City	SFR-Basic
05 118255 RK	CITY	City	SFR-Basic
05 120806 RK	CITY	City	SFR-Basic
05 120202 RK	CITY	City	SFR-Basic
05 118238 RK	CITY	City	SFR-Basic
05 121278 RK	CITY	City	SFR-Basic
05 119704 RK	CITY	City	SFR-Basic
05 120812 RK	CITY	City	SFR-Basic
05 118230 RK	CITY	City	SFR-Basic
05 118244 RK	CITY	City	SFR-Basic
05 118259 RK	CITY	City	SFR-Basic
05 120807 RK	CITY	City	SFR-Basic
05 118239 RK	CITY	City	SFR-Basic
05 121284 RK	CITY	City	SFR-Basic
05 125212 RK	CITY	City	SFR-Basic
05 121759 RK	CITY	City	SFR-Basic
05 121775 RK	CITY	City	SFR-Basic
05 121773 RK	CITY	City	SFR-Basic
05 121771 RK	CITY	City	SFR-Basic
05 124309 RK	CITY	City	SFR-Basic
05 124310 RK	CITY	City	SFR-Basic
05 124311 RK	CITY	City	SFR-Basic
05 121772 RK	CITY	City	SFR-Basic
05 122468 RK	CITY	City	SFR-Basic
05 124315 RK	CITY	City	SFR-Basic
04 119567 RK	CITY	City	SFR-Basic
04 119569 RK	CITY	City	SFR-Basic
04 119570 RK	CITY	City	SFR-Basic
04 119568 RK	CITY	City	SFR-Basic
05 124314 RK	CITY	City	SFR-Basic
05 123682 RK	CITY	City	SFR-Basic
05 121770 RK	CITY	City	SFR-Basic
05 121778 RK	CITY	City	SFR-Basic
05 121760 RK	CITY	City	SFR-Basic
05 123686 RK	CITY	City	SFR-Basic
05 123687 RK	CITY	City	SFR-Basic
05 121275 RK	CITY	City	SFR-Basic
05 124316 RK	CITY	City	SFR-Basic
05 124306 RK	CITY	City	SFR-Basic
05 116347 RK	CITY	City	SFR-Basic
05 116930 RK	CITY	City	SFR-Basic
05 116924 RK	CITY	City	SFR-Basic
05 100305 RK	CITY	City	SFR-Basic
04 120937 RK	CITY	City	SFR-Basic
05 121780 RK	CITY	City	SFR-Basic

Accessory Dwelling Units

Index # - File Name: 1.0022 - Single Family Dwellings Data\_Snohomish County.pdf

05 121767 RK	CITY	City	SFR-Basic
05 121276 RK	CITY	City	SFR-Basic
05 121763 RK	CITY	City	SFR-Basic
05 121761 RK	CITY	City	SFR-Basic
05 124318 RK	CITY	City	SFR-Basic
05 124319 RK	CITY	City	SFR-Basic
05 122465 RK	CITY	City	SFR-Basic
05 124307 RK	CITY	City	SFR-Basic
05 124308 RK	CITY	City	SFR-Basic
05 121774 RK	CITY	City	SFR-Basic
05 122467 RK	CITY	City	SFR-Basic
05 124320 RK	CITY	City	SFR-Basic
05 121680 RK	PRD-20,000	Residential 20,000 sq. ft.	SFR-Basic
05 121685 RK	PRD-20,000	Residential 20,000 sq. ft.	SFR-Basic
05 121458 RK	PRD-20,000	Residential 20,000 sq. ft.	SFR-Basic
05 127360 RK	PRD-20,000	Residential 20,000 sq. ft.	SFR-Basic
05 121245 RK	PRD-20,000	Residential 20,000 sq. ft.	SFR-Basic
05 120009 RK	PRD-20,000	Residential 20,000 sq. ft.	SFR-Basic
05 121243 RK	PRD-20,000	Residential 20,000 sq. ft.	SFR-Basic
05 121037 RK	PRD-20,000	Residential 20,000 sq. ft.	SFR-Basic
05 122163 RK	PRD-20,000	Residential 20,000 sq. ft.	SFR-Basic
05 100037 RK	R-5	Rural-5 Acre	Single Family Res-Combo
05 129009 RK	PRD-20,000	Residential 20,000 sq. ft.	SFR-Basic
05 129010 RK	PRD-20,000	Residential 20,000 sq. ft.	SFR-Basic
05 100956 RK	R-5	Rural-5 Acre	Single Family Res-Combo
05 120455 RK	R-5	Rural-5 Acre	Single Family Res-Combo
05 101002 RK	R-5	Rural-5 Acre	Single Family Res-Combo
05 101199 RK	R-5	Rural-5 Acre	Single Family Res-Combo
05 101239 RK	R-5	Rural-5 Acre	Single Family Res-Combo
05 101390 RK	F	Forestry	Single Family Res-Combo
05 116804 RK	R-5	Rural-5 Acre	Single Family Res-Combo
05 127226 RK	PRD-20,000	Residential 20,000 sq. ft.	SFR-Basic
05 128176 RK	PRD-20,000	Residential 20,000 sq. ft.	SFR-Basic
05 128179 RK	PRD-20,000	Residential 20,000 sq. ft.	SFR-Basic
05 121068 RK	PRD-20,000	Residential 20,000 sq. ft.	SFR-Basic
05 120752 RK	PRD-20,000	Residential 20,000 sq. ft.	SFR-Basic
05 120753 RK	PRD-20,000	Residential 20,000 sq. ft.	SFR-Basic
05 121544 RK	PRD-20,000	Residential 20,000 sq. ft.	SFR-Basic
05 127224 RK	PRD-20,000	Residential 20,000 sq. ft.	SFR-Basic
05 128182 RK	PRD-20,000	Residential 20,000 sq. ft.	SFR-Basic
05 124364 RK	PRD-20,000	Residential 20,000 sq. ft.	SFR-Basic
05 123478 RK	PRD-20,000	Residential 20,000 sq. ft.	SFR-Basic
05 123727 RK	PRD-20,000	Residential 20,000 sq. ft.	SFR-Basic
05 121663 RK	PRD-20,000	Residential 20,000 sq. ft.	SFR-Basic
05 125964 RK	PRD-20,000	Residential 20,000 sq. ft.	SFR-Basic
05 121667 RK	PRD-20,000	Residential 20,000 sq. ft.	SFR-Basic
05 123728 RK	PRD-20,000	Residential 20,000 sq. ft.	SFR-Basic

Accessory Dwelling Units

Index # - File Name: 1.0022 - Single Family Dwellings Data\_Snohomish County.pdf

05 124362 RK	PRD-20,000	Residential 20,000 sq. ft.	SFR-Basic
05 124359 RK	PRD-20,000	Residential 20,000 sq. ft.	SFR-Basic
05 124961 RK	PRD-20,000	Residential 20,000 sq. ft.	SFR-Basic
05 124962 RK	PRD-20,000	Residential 20,000 sq. ft.	SFR-Basic
05 124963 RK	PRD-20,000	Residential 20,000 sq. ft.	SFR-Basic
05 127227 RK	PRD-20,000	Residential 20,000 sq. ft.	SFR-Basic
05 127231 RK	PRD-20,000	Residential 20,000 sq. ft.	SFR-Basic
05 127232 RK	PRD-20,000	Residential 20,000 sq. ft.	SFR-Basic
05 101969 RK	A-10	Agriculture-10 Acre	Single Family Res-Combo
05 122284 RK	R-5	Rural-5 Acre	Single Family Res-Combo
05 119705 RK	R-5	Rural-5 Acre	Single Family Res-Combo
05 120658 RK	PRD-20,000	Residential 20,000 sq. ft.	SFR-Basic
05 119423 RK	R-5	Rural-5 Acre	Single Family Res-Combo
05 124949 RK	R-5	Rural-5 Acre	Single Family Res-Combo
05 124811 RK	R-5	Rural-5 Acre	SFR-Basic
05 124815 RK	R-5	Rural-5 Acre	SFR-Basic
05 122347 RK	R-5	Rural-5 Acre	SFR-Basic
05 122934 RK	R-5	Rural-5 Acre	SFR-Basic
05 124292 RK	R-5	Rural-5 Acre	Single Family Res-Combo
05 101952 RK	R-7,200	Residential 7,200 sq. ft.	Duplex-Combo
05 102091 RK	R-5	Rural-5 Acre	SFR-Basic
05 120404 RK	R-5	Rural-5 Acre	Single Family Res-Combo
05 122343 RK	R-5	Rural-5 Acre	Single Family Res-Combo
05 120408 RK	R-5	Rural-5 Acre	SFR-Basic
05 120406 RK	R-5	Rural-5 Acre	SFR-Basic
05 122341 RK	R-5	Rural-5 Acre	Single Family Res-Combo
05 120407 RK	R-5	Rural-5 Acre	SFR-Basic
05 118669 RK	R-7,200	Residential 7,200 sq. ft.	SFR-Basic
05 118674 RK	R-7,200	Residential 7,200 sq. ft.	SFR-Basic
05 118785 RK	R-7,200	Residential 7,200 sq. ft.	SFR-Basic
05 118738 RK	R-7,200	Residential 7,200 sq. ft.	SFR-Basic
05 118787 RK	R-7,200	Residential 7,200 sq. ft.	SFR-Basic
05 123714 RK	R-7,200	Residential 7,200 sq. ft.	SFR-Basic
05 119742 RK	R-7,200	Residential 7,200 sq. ft.	SFR-Basic
05 118723 RK	R-7,200	Residential 7,200 sq. ft.	SFR-Basic
05 118722 RK	R-7,200	Residential 7,200 sq. ft.	SFR-Basic
05 118725 RK	R-7,200	Residential 7,200 sq. ft.	SFR-Basic
05 119445 RK	R-7,200	Residential 7,200 sq. ft.	SFR-Basic
05 119444 RK	R-7,200	Residential 7,200 sq. ft.	SFR-Basic
05 118729 RK	R-7,200	Residential 7,200 sq. ft.	SFR-Basic
05 123024 RK	R-7,200	Residential 7,200 sq. ft.	SFR-Basic
05 119448 RK	R-7,200	Residential 7,200 sq. ft.	SFR-Basic
05 118730 RK	R-7,200	Residential 7,200 sq. ft.	SFR-Basic
05 118731 RK	R-7,200	Residential 7,200 sq. ft.	SFR-Basic
05 119449 RK	R-7,200	Residential 7,200 sq. ft.	SFR-Basic
05 119997 RK	R-7,200	Residential 7,200 sq. ft.	Single Family Res-Combo
05 120862 RK	R-7,200	Residential 7,200 sq. ft.	SFR-Basic

Accessory Dwelling Units

Index # - File Name: 1.0022 - Single Family Dwellings Data\_Snohomish County.pdf

05 120852 RK	R-7,200	Residential 7,200 sq. ft.	SFR-Basic
05 119242 RK	R-7,200	Residential 7,200 sq. ft.	SFR-Basic
05 120002 RK	R-7,200	Residential 7,200 sq. ft.	SFR-Basic
05 121492 RK	R-7,200	Residential 7,200 sq. ft.	Single Family Res-Combo
05 119241 RK	R-7,200	Residential 7,200 sq. ft.	Single Family Res-Combo
05 120863 RK	R-7,200	Residential 7,200 sq. ft.	SFR-Basic
05 120858 RK	R-7,200	Residential 7,200 sq. ft.	SFR-Basic
05 121494 RK	R-7,200	Residential 7,200 sq. ft.	Single Family Res-Combo
05 121776 RK	R-7,200	Residential 7,200 sq. ft.	Single Family Res-Combo
05 121419 RK	R-7,200	Residential 7,200 sq. ft.	SFR-Basic
05 121421 RK	R-7,200	Residential 7,200 sq. ft.	SFR-Basic
05 120507 RK	R-7,200	Residential 7,200 sq. ft.	Single Family Res-Combo
05 118640 RK	R-7,200	Residential 7,200 sq. ft.	SFR-Basic
05 120152 RK	R-7,200	Residential 7,200 sq. ft.	SFR-Basic
05 118882 RK	R-7,200	Residential 7,200 sq. ft.	SFR-Basic
05 118884 RK	R-7,200	Residential 7,200 sq. ft.	SFR-Basic
05 120150 RK	R-7,200	Residential 7,200 sq. ft.	SFR-Basic
05 123794 RK	R-7,200	Residential 7,200 sq. ft.	Single Family Res-Combo
05 125053 RK	R-7,200	Residential 7,200 sq. ft.	SFR-Basic
05 122157 RK	R-7,200	Residential 7,200 sq. ft.	SFR-Basic
05 122158 RK	R-7,200	Residential 7,200 sq. ft.	SFR-Basic
05 118642 RK	R-7,200	Residential 7,200 sq. ft.	Single Family Res-Combo
05 118641 RK	R-7,200	Residential 7,200 sq. ft.	SFR-Basic
05 120509 RK	R-7,200	Residential 7,200 sq. ft.	Single Family Res-Combo
05 101887 RK	MR	Multiple Residential	Single Family Res-Combo
05 116214 RK	R-5	Rural-5 Acre	Single Family Res-Combo
05 116277 RK	R-5	Rural-5 Acre	Single Family Res-Combo
05 123517 RK	F	Forestry	Single Family Res-Combo
05 119730 RK	R-7,200	Residential 7,200 sq. ft.	Single Family Res-Combo
05 119732 RK	R-7,200	Residential 7,200 sq. ft.	Single Family Res-Combo
05 121902 RK	R-7,200	Residential 7,200 sq. ft.	Single Family Res-Combo
05 123453 RK	R-7,200	Residential 7,200 sq. ft.	Single Family Res-Combo
05 125218 RK	R-7,200	Residential 7,200 sq. ft.	Single Family Res-Combo
05 123455 RK	R-7,200	Residential 7,200 sq. ft.	Single Family Res-Combo
05 126329 RK	R-5	Rural-5 Acre	Single Family Res-Combo
05 116931 RK	R-5	Rural-5 Acre	Single Family Res-Combo
04 117488 RK	R-5	Rural-5 Acre	Single Family Res-Combo
04 117489 RK	R-5	Rural-5 Acre	Single Family Res-Combo
05 122349 RK	R-5	Rural-5 Acre	SFR-Basic
05 124769 RK	R-7,200	Residential 7,200 sq. ft.	Single Family Res-Combo
05 124442 RK	R-7,200	Residential 7,200 sq. ft.	Single Family Res-Combo
05 124443 RK	R-7,200	Residential 7,200 sq. ft.	Single Family Res-Combo
05 123456 RK	R-7,200	Residential 7,200 sq. ft.	Single Family Res-Combo
05 124444 RK	R-7,200	Residential 7,200 sq. ft.	Single Family Res-Combo
05 121905 RK	R-7,200	Residential 7,200 sq. ft.	Single Family Res-Combo
05 120835 RK	R-7,200	Residential 7,200 sq. ft.	Single Family Res-Combo
05 116600 RK	R-5	Rural-5 Acre	Duplex-Combo

Accessory Dwelling Units

Index # - File Name: 1.0022 - Single Family Dwellings Data\_Snohomish County.pdf

05 117643 RK	LDMR	Low Density Multiple Reside SFR-Basic	
05 117644 RK	LDMR	Low Density Multiple Reside SFR-Basic	
05 117660 RK	LDMR	Low Density Multiple Reside SFR-Basic	
05 117659 RK	LDMR	Low Density Multiple Reside SFR-Basic	
05 117641 RK	LDMR	Low Density Multiple Reside SFR-Basic	
05 117653 RK	LDMR	Low Density Multiple Reside SFR-Basic	
05 117661 RK	LDMR	Low Density Multiple Reside SFR-Basic	
05 117658 RK	LDMR	Low Density Multiple Reside SFR-Basic	
05 124748 RK	LDMR	Low Density Multiple Reside SFR-Basic	
05 117646 RK	LDMR	Low Density Multiple Reside SFR-Basic	
05 117647 RK	LDMR	Low Density Multiple Reside SFR-Basic	
05 117650 RK	LDMR	Low Density Multiple Reside SFR-Basic	
05 117656 RK	LDMR	Low Density Multiple Reside SFR-Basic	
05 117649 RK	LDMR	Low Density Multiple Reside SFR-Basic	
05 117648 RK	LDMR	Low Density Multiple Reside SFR-Basic	
05 116336 RK	LDMR	Low Density Multiple Reside SFR-Basic	
05 117645 RK	LDMR	Low Density Multiple Reside SFR-Basic	
05 117642 RK	LDMR	Low Density Multiple Reside SFR-Basic	
05 117655 RK	LDMR	Low Density Multiple Reside SFR-Basic	
05 117654 RK	LDMR	Low Density Multiple Reside SFR-Basic	
05 117651 RK	LDMR	Low Density Multiple Reside SFR-Basic	
05 121241 RK	R-7,200	Residential 7,200 sq. ft.	SFR-Basic
05 119693 RK	R-7,200	Residential 7,200 sq. ft.	SFR-Basic
05 118283 RK	R-7,200	Residential 7,200 sq. ft.	SFR-Basic
05 126210 RK	R-7,200	Residential 7,200 sq. ft.	SFR-Basic
05 118634 RK	R-7,200	Residential 7,200 sq. ft.	SFR-Basic
05 127552 RK	R-7,200	Residential 7,200 sq. ft.	SFR-Basic
05 118200 RK	R-7,200	Residential 7,200 sq. ft.	SFR-Basic
05 128652 RK	R-7,200	Residential 7,200 sq. ft.	SFR-Basic
05 121225 RK	R-7,200	Residential 7,200 sq. ft.	SFR-Basic
05 121219 RK	R-7,200	Residential 7,200 sq. ft.	SFR-Basic
05 126871 RK	R-7,200	Residential 7,200 sq. ft.	SFR-Basic
05 128669 RK	R-7,200	Residential 7,200 sq. ft.	SFR-Basic
05 125685 RK	R-7,200	Residential 7,200 sq. ft.	SFR-Basic
05 125682 RK	R-7,200	Residential 7,200 sq. ft.	Single Family Res-Combo
05 119671 RK	R-7,200	Residential 7,200 sq. ft.	Single Family Res-Combo
05 123118 RK	R-7,200	Residential 7,200 sq. ft.	SFR-Basic
05 124116 RK	R-7,200	Residential 7,200 sq. ft.	SFR-Basic
05 124130 RK	R-7,200	Residential 7,200 sq. ft.	SFR-Basic
05 121240 RK	R-7,200	Residential 7,200 sq. ft.	SFR-Basic
05 122071 RK	R-7,200	Residential 7,200 sq. ft.	SFR-Basic
05 125483 RK	R-7,200	Residential 7,200 sq. ft.	SFR-Basic
05 123584 RK	R-7,200	Residential 7,200 sq. ft.	SFR-Basic
05 118885 RK	R-7,200	Residential 7,200 sq. ft.	SFR-Basic
05 127951 RK	R-7,200	Residential 7,200 sq. ft.	SFR-Basic
05 128668 RK	R-7,200	Residential 7,200 sq. ft.	SFR-Basic
05 126870 RK	R-7,200	Residential 7,200 sq. ft.	SFR-Basic

Accessory Dwelling Units

Index # - File Name: 1.0022 - Single Family Dwellings Data\_Snohomish County.pdf

05 124114 RK	R-7,200	Residential 7,200 sq. ft.	SFR-Basic
05 120913 RK	R-7,200	Residential 7,200 sq. ft.	SFR-Basic
05 118207 RK	R-7,200	Residential 7,200 sq. ft.	SFR-Basic
05 118203 RK	R-7,200	Residential 7,200 sq. ft.	SFR-Basic
05 118210 RK	R-7,200	Residential 7,200 sq. ft.	SFR-Basic
05 118277 RK	R-7,200	Residential 7,200 sq. ft.	Single Family Res-Combo
05 118879 RK	R-7,200	Residential 7,200 sq. ft.	SFR-Basic
05 118280 RK	R-7,200	Residential 7,200 sq. ft.	SFR-Basic
05 118282 RK	R-7,200	Residential 7,200 sq. ft.	SFR-Basic
05 118633 RK	R-7,200	Residential 7,200 sq. ft.	SFR-Basic
05 121378 RK	R-7,200	Residential 7,200 sq. ft.	SFR-Basic
05 127544 RK	R-7,200	Residential 7,200 sq. ft.	SFR-Basic
05 127551 RK	R-7,200	Residential 7,200 sq. ft.	SFR-Basic
05 128313 RK	R-7,200	Residential 7,200 sq. ft.	SFR-Basic
05 128314 RK	R-7,200	Residential 7,200 sq. ft.	SFR-Basic
05 127548 RK	R-7,200	Residential 7,200 sq. ft.	SFR-Basic
05 128650 RK	R-7,200	Residential 7,200 sq. ft.	SFR-Basic
05 127549 RK	R-7,200	Residential 7,200 sq. ft.	SFR-Basic
05 126386 RK	R-7,200	Residential 7,200 sq. ft.	SFR-Basic
05 118886 RK	R-7,200	Residential 7,200 sq. ft.	Single Family Res-Combo
05 126214 RK	R-7,200	Residential 7,200 sq. ft.	SFR-Basic
05 126221 RK	R-7,200	Residential 7,200 sq. ft.	SFR-Basic
05 124132 RK	R-7,200	Residential 7,200 sq. ft.	SFR-Basic
05 124113 RK	R-7,200	Residential 7,200 sq. ft.	SFR-Basic
05 122072 RK	R-7,200	Residential 7,200 sq. ft.	SFR-Basic
05 119694 RK	R-7,200	Residential 7,200 sq. ft.	SFR-Basic
05 118287 RK	R-7,200	Residential 7,200 sq. ft.	SFR-Basic
05 119994 RK	R-7,200	Residential 7,200 sq. ft.	SFR-Basic
05 124468 RK	R-7,200	Residential 7,200 sq. ft.	SFR-Basic
05 119993 RK	R-7,200	Residential 7,200 sq. ft.	SFR-Basic
05 127547 RK	R-7,200	Residential 7,200 sq. ft.	SFR-Basic
05 120469 RK	R-7,200	Residential 7,200 sq. ft.	SFR-Basic
05 125686 RK	R-7,200	Residential 7,200 sq. ft.	SFR-Basic
05 120470 RK	R-7,200	Residential 7,200 sq. ft.	SFR-Basic
05 119995 RK	R-7,200	Residential 7,200 sq. ft.	SFR-Basic
05 125687 RK	R-7,200	Residential 7,200 sq. ft.	SFR-Basic
05 123585 RK	R-7,200	Residential 7,200 sq. ft.	SFR-Basic
05 119896 RK	R-7,200	Residential 7,200 sq. ft.	SFR-Basic
05 120911 RK	R-7,200	Residential 7,200 sq. ft.	SFR-Basic
05 123120 RK	R-7,200	Residential 7,200 sq. ft.	SFR-Basic
05 123121 RK	R-7,200	Residential 7,200 sq. ft.	SFR-Basic
05 119996 RK	R-7,200	Residential 7,200 sq. ft.	SFR-Basic
05 125480 RK	R-7,200	Residential 7,200 sq. ft.	SFR-Basic
05 118856 RK	R-7,200	Residential 7,200 sq. ft.	SFR-Basic
05 117131 RK	CITY	City	Single Family Res-Combo
05 121684 RK	CITY	City	SFR-Basic
05 117916 RK	CITY	City	SFR-Basic

Accessory Dwelling Units

Index # - File Name: 1.0022 - Single Family Dwellings Data\_Snohomish County.pdf

05 117917 RK	CITY	City	SFR-Basic
05 121687 RK	CITY	City	SFR-Basic
05 121689 RK	CITY	City	SFR-Basic
05 123238 RK	CITY	City	SFR-Basic
05 121690 RK	CITY	City	SFR-Basic
05 121691 RK	CITY	City	SFR-Basic
05 121692 RK	CITY	City	SFR-Basic
05 125154 RK	CITY	City	SFR-Basic
05 121694 RK	CITY	City	SFR-Basic
05 121695 RK	CITY	City	SFR-Basic
05 121696 RK	CITY	City	SFR-Basic
05 121698 RK	CITY	City	SFR-Basic
05 121700 RK	CITY	City	SFR-Basic
05 121702 RK	CITY	City	SFR-Basic
05 117918 RK	CITY	City	SFR-Basic
05 117919 RK	CITY	City	SFR-Basic
05 117920 RK	CITY	City	SFR-Basic
05 118796 RK	CITY	City	SFR-Basic
05 119070 RK	CITY	City	SFR-Basic
05 119071 RK	CITY	City	SFR-Basic
05 120846 RK	CITY	City	SFR-Basic
05 119678 RK	CITY	City	SFR-Basic
05 120848 RK	CITY	City	SFR-Basic
05 120847 RK	CITY	City	SFR-Basic
05 119681 RK	CITY	City	SFR-Basic
05 120849 RK	CITY	City	SFR-Basic
05 120850 RK	CITY	City	SFR-Basic
05 119680 RK	CITY	City	SFR-Basic
05 121703 RK	CITY	City	SFR-Basic
05 121429 RK	CITY	City	SFR-Basic
05 121430 RK	CITY	City	SFR-Basic
05 118797 RK	CITY	City	SFR-Basic
05 118798 RK	CITY	City	SFR-Basic
05 118799 RK	CITY	City	SFR-Basic
05 118373 RK	CITY	City	SFR-Basic
05 118375 RK	CITY	City	SFR-Basic
05 118376 RK	CITY	City	SFR-Basic
05 120229 RK	CITY	City	SFR-Basic
05 121705 RK	CITY	City	SFR-Basic
05 121706 RK	CITY	City	SFR-Basic
05 121675 RK	CITY	City	SFR-Basic
05 121681 RK	CITY	City	SFR-Basic
05 123239 RK	CITY	City	SFR-Basic
05 121709 RK	CITY	City	SFR-Basic
05 126630 RK	PRD-9,600	Residential 9,600 sq. ft.	Single Family Res-Combo
05 122744 RK	PRD-9,600	Residential 9,600 sq. ft.	SFR-Basic
05 123493 RK	PRD-9,600	Residential 9,600 sq. ft.	SFR-Basic



Accessory Dwelling Units

Index # - File Name: 1.0022 - Single Family Dwellings Data\_Snohomish County.pdf

05 122740 RK	PRD-9,600	Residential 9,600 sq. ft.	SFR-Basic
05 117683 RK	PRD-9,600	Residential 9,600 sq. ft.	SFR-Basic
05 122736 RK	PRD-9,600	Residential 9,600 sq. ft.	SFR-Basic
05 122731 RK	PRD-9,600	Residential 9,600 sq. ft.	SFR-Basic
05 122733 RK	PRD-9,600	Residential 9,600 sq. ft.	SFR-Basic
05 123681 RK	PRD-9,600	Residential 9,600 sq. ft.	SFR-Basic
05 122915 RK	PRD-9,600	Residential 9,600 sq. ft.	SFR-Basic
05 120122 RK	R-9,600(PRD)	Residential 9,600 sq. ft.	SFR-Basic
05 121506 RK	R-9,600(PRD)	Residential 9,600 sq. ft.	SFR-Basic
05 122764 RK	R-9,600(PRD)	Residential 9,600 sq. ft.	SFR-Basic
05 126022 RK	R-9,600(PRD)	Residential 9,600 sq. ft.	SFR-Basic
05 120244 RK	R-9,600(PRD)	Residential 9,600 sq. ft.	SFR-Basic
05 120245 RK	R-9,600(PRD)	Residential 9,600 sq. ft.	SFR-Basic
05 121063 RK	R-9,600(PRD)	Residential 9,600 sq. ft.	SFR-Basic
05 120247 RK	R-9,600(PRD)	Residential 9,600 sq. ft.	SFR-Basic
05 120248 RK	R-9,600(PRD)	Residential 9,600 sq. ft.	SFR-Basic
05 121065 RK	R-9,600(PRD)	Residential 9,600 sq. ft.	SFR-Basic
05 120249 RK	R-9,600(PRD)	Residential 9,600 sq. ft.	SFR-Basic
05 120250 RK	R-9,600(PRD)	Residential 9,600 sq. ft.	SFR-Basic
05 120251 RK	R-9,600(PRD)	Residential 9,600 sq. ft.	SFR-Basic
05 120252 RK	R-9,600(PRD)	Residential 9,600 sq. ft.	SFR-Basic
05 120253 RK	R-9,600(PRD)	Residential 9,600 sq. ft.	SFR-Basic
05 120254 RK	R-9,600(PRD)	Residential 9,600 sq. ft.	SFR-Basic
05 118317 RK	R-9,600(PRD)	Residential 9,600 sq. ft.	SFR-Basic
05 118318 RK	R-9,600(PRD)	Residential 9,600 sq. ft.	SFR-Basic
05 118319 RK	R-9,600(PRD)	Residential 9,600 sq. ft.	SFR-Basic
05 118322 RK	R-9,600(PRD)	Residential 9,600 sq. ft.	SFR-Basic
05 118320 RK	R-9,600(PRD)	Residential 9,600 sq. ft.	SFR-Basic
05 118012 RK	R-9,600(PRD)	Residential 9,600 sq. ft.	SFR-Basic
05 118013 RK	R-9,600(PRD)	Residential 9,600 sq. ft.	SFR-Basic
05 118014 RK	R-9,600(PRD)	Residential 9,600 sq. ft.	SFR-Basic
05 116780 RK	R-9,600(PRD)	Residential 9,600 sq. ft.	SFR-Basic
05 118011 RK	R-9,600(PRD)	Residential 9,600 sq. ft.	SFR-Basic
05 118015 RK	R-9,600(PRD)	Residential 9,600 sq. ft.	SFR-Basic
05 116783 RK	R-9,600(PRD)	Residential 9,600 sq. ft.	SFR-Basic
05 101232 RK	R-9,600(PRD)	Residential 9,600 sq. ft.	SFR-Basic
05 101107 RK	R-9,600(PRD)	Residential 9,600 sq. ft.	SFR-Basic
05 101231 RK	R-9,600(PRD)	Residential 9,600 sq. ft.	SFR-Basic
05 100219 RK	CITY	City	SFR-Basic
05 100216 RK	CITY	City	SFR-Basic
05 100217 RK	CITY	City	SFR-Basic
05 116963 RK	CITY	City	SFR-Basic
05 101104 RK	CITY	City	SFR-Basic
05 101105 RK	CITY	City	SFR-Basic
05 101229 RK	CITY	City	SFR-Basic
05 101230 RK	CITY	City	SFR-Basic
05 101103 RK	CITY	City	SFR-Basic

Accessory Dwelling Units

Index # - File Name: 1.0022 - Single Family Dwellings Data\_Snohomish County.pdf

05 124273 RK	CITY	City	SFR-Basic
05 122766 RK	CITY	City	SFR-Basic
05 124470 RK	CITY	City	SFR-Basic
05 121493 RK	CITY	City	SFR-Basic
05 120126 RK	CITY	City	SFR-Basic
05 122226 RK	CITY	City	SFR-Basic
05 122767 RK	CITY	City	SFR-Basic
05 124939 RK	CITY	City	SFR-Basic
05 124938 RK	CITY	City	SFR-Basic
05 122768 RK	CITY	City	SFR-Basic
05 117754 RK	CITY	City	SFR-Basic
05 116240 RK	CITY	City	SFR-Basic
05 126430 RK	PRD-9,600	Residential 9,600 sq. ft.	Single Family Res-Combo
05 126431 RK	PRD-9,600	Residential 9,600 sq. ft.	Single Family Res-Combo
05 123685 RK	PRD-9,600	Residential 9,600 sq. ft.	SFR-Basic
05 121322 RK	PRD-9,600	Residential 9,600 sq. ft.	SFR-Basic
05 121324 RK	PRD-9,600	Residential 9,600 sq. ft.	SFR-Basic
05 125182 RK	PRD-9,600	Residential 9,600 sq. ft.	SFR-Basic
05 125183 RK	PRD-9,600	Residential 9,600 sq. ft.	SFR-Basic
05 125189 RK	PRD-9,600	Residential 9,600 sq. ft.	SFR-Basic
05 121325 RK	PRD-9,600	Residential 9,600 sq. ft.	SFR-Basic
05 120046 RK	PRD-9,600	Residential 9,600 sq. ft.	SFR-Basic
05 120047 RK	PRD-9,600	Residential 9,600 sq. ft.	SFR-Basic
05 120048 RK	PRD-9,600	Residential 9,600 sq. ft.	SFR-Basic
05 120050 RK	PRD-9,600	Residential 9,600 sq. ft.	SFR-Basic
05 125184 RK	PRD-9,600	Residential 9,600 sq. ft.	SFR-Basic
05 125187 RK	PRD-9,600	Residential 9,600 sq. ft.	SFR-Basic
05 126258 RK	PRD-9,600	Residential 9,600 sq. ft.	SFR-Basic
05 123499 RK	PRD-9,600	Residential 9,600 sq. ft.	SFR-Basic
05 122155 RK	PRD-9,600	Residential 9,600 sq. ft.	SFR-Basic
05 121327 RK	PRD-9,600	Residential 9,600 sq. ft.	SFR-Basic
05 121328 RK	PRD-9,600	Residential 9,600 sq. ft.	SFR-Basic
05 117684 RK	PRD-9,600	Residential 9,600 sq. ft.	SFR-Basic
05 100403 RK	PRD-9,600	Residential 9,600 sq. ft.	SFR-Basic
05 116200 RK	PRD-9,600	Residential 9,600 sq. ft.	SFR-Basic
05 100404 RK	PRD-9,600	Residential 9,600 sq. ft.	SFR-Basic
05 117680 RK	PRD-9,600	Residential 9,600 sq. ft.	SFR-Basic
05 117686 RK	PRD-9,600	Residential 9,600 sq. ft.	SFR-Basic
05 117687 RK	PRD-9,600	Residential 9,600 sq. ft.	SFR-Basic
05 118474 RK	PRD-9,600	Residential 9,600 sq. ft.	SFR-Basic
05 116201 RK	PRD-9,600	Residential 9,600 sq. ft.	Single Family Res-Combo
05 100405 RK	PRD-9,600	Residential 9,600 sq. ft.	SFR-Basic
05 116203 RK	PRD-9,600	Residential 9,600 sq. ft.	SFR-Basic
05 100406 RK	PRD-9,600	Residential 9,600 sq. ft.	SFR-Basic
05 116204 RK	PRD-9,600	Residential 9,600 sq. ft.	SFR-Basic
05 116205 RK	PRD-9,600	Residential 9,600 sq. ft.	SFR-Basic
05 100747 RK	PRD-9,600	Residential 9,600 sq. ft.	SFR-Basic

Accessory Dwelling Units

Index # - File Name: 1.0022 - Single Family Dwellings Data\_Snohomish County.pdf

05 116320 RK	F	Forestry	Single Family Res-Combo
04 121282 RK	R-5	Rural-5 Acre	SFR-Basic
05 100013 RK	R-7,200	Residential 7,200 sq. ft.	SFR-Basic
05 101297 RK	R-7,200	Residential 7,200 sq. ft.	SFR-Basic
05 101299 RK	R-7,200	Residential 7,200 sq. ft.	SFR-Basic
04 113877 RK	MR	Multiple Residential	Duplex-Combo
04 113886 RK	MR	Multiple Residential	Duplex-Combo
04 113878 RK	MR	Multiple Residential	Duplex-Combo
04 118790 MH	R-5	Rural-5 Acre	Double Wide
04 118568 RK	R-5	Rural-5 Acre	Single Family Res-Combo
05 118016 RK	RD	Rural Diversification	Single Family Res-Combo
04 118075 RK	R-5	Rural-5 Acre	SFR-Basic
04 121280 RK	R-5	Rural-5 Acre	SFR-Basic
05 129171 RK	R-7,200	Residential 7,200 sq. ft.	SFR-Basic
05 129139 RK	R-7,200	Residential 7,200 sq. ft.	SFR-Basic
05 129138 RK	R-7,200	Residential 7,200 sq. ft.	SFR-Basic
05 126560 RK	R-7,200	Residential 7,200 sq. ft.	SFR-Basic
05 126562 RK	R-7,200	Residential 7,200 sq. ft.	SFR-Basic
05 126563 RK	R-7,200	Residential 7,200 sq. ft.	SFR-Basic
05 127521 RK	R-7,200	Residential 7,200 sq. ft.	Single Family Res-Combo
05 123092 RK	R-7,200	Residential 7,200 sq. ft.	Single Family Res-Combo
05 126557 RK	R-7,200	Residential 7,200 sq. ft.	Single Family Res-Combo
05 123483 RK	R-7,200	Residential 7,200 sq. ft.	SFR-Basic
05 123484 RK	R-7,200	Residential 7,200 sq. ft.	Single Family Res-Combo
05 123485 RK	R-7,200	Residential 7,200 sq. ft.	Single Family Res-Combo
05 121141 RK	R-7,200	Residential 7,200 sq. ft.	SFR-Basic
05 120049 RK	R-7,200	Residential 7,200 sq. ft.	SFR-Basic
05 120052 RK	R-7,200	Residential 7,200 sq. ft.	SFR-Basic
05 120055 RK	R-7,200	Residential 7,200 sq. ft.	SFR-Basic
05 119754 RK	R-7,200	Residential 7,200 sq. ft.	Single Family Res-Combo
05 119753 RK	R-7,200	Residential 7,200 sq. ft.	Single Family Res-Combo
05 119217 RK	R-7,200	Residential 7,200 sq. ft.	Single Family Res-Combo
05 120938 RK	R-7,200	Residential 7,200 sq. ft.	Single Family Res-Combo
05 119518 RK	R-7,200	Residential 7,200 sq. ft.	Single Family Res-Combo
05 125087 RK	R-7,200	Residential 7,200 sq. ft.	Single Family Res-Combo
05 123574 RK	R-7,200	Residential 7,200 sq. ft.	Single Family Res-Combo
05 124917 RK	R-7,200	Residential 7,200 sq. ft.	Single Family Res-Combo
05 126521 RK	R-7,200	Residential 7,200 sq. ft.	Single Family Res-Combo
05 123573 RK	R-7,200	Residential 7,200 sq. ft.	Single Family Res-Combo
05 123575 RK	R-7,200	Residential 7,200 sq. ft.	Single Family Res-Combo
05 129145 RK	R-7,200	Residential 7,200 sq. ft.	SFR-Basic
05 129134 RK	R-7,200	Residential 7,200 sq. ft.	SFR-Basic
05 127864 RK	R-7,200	Residential 7,200 sq. ft.	SFR-Basic
05 127865 RK	R-7,200	Residential 7,200 sq. ft.	SFR-Basic
05 127866 RK	R-7,200	Residential 7,200 sq. ft.	SFR-Basic
05 127867 RK	R-7,200	Residential 7,200 sq. ft.	SFR-Basic
05 127868 RK	R-7,200	Residential 7,200 sq. ft.	SFR-Basic

Accessory Dwelling Units

Index # - File Name: 1.0022 - Single Family Dwellings Data\_Snohomish County.pdf

05 126566 RK	R-7,200	Residential 7,200 sq. ft.	SFR-Basic
05 100567 RK	R-7,200	Residential 7,200 sq. ft.	Single Family Res-Combo
05 116408 RK	R-7,200	Residential 7,200 sq. ft.	Single Family Res-Combo
04 121584 RK	R-7,200	Residential 7,200 sq. ft.	Single Family Res-Combo
05 101007 RK	R-7,200	Residential 7,200 sq. ft.	Single Family Res-Combo
05 121143 RK	R-7,200	Residential 7,200 sq. ft.	SFR-Basic
05 121144 RK	R-7,200	Residential 7,200 sq. ft.	SFR-Basic
05 121145 RK	R-7,200	Residential 7,200 sq. ft.	SFR-Basic
05 121146 RK	R-7,200	Residential 7,200 sq. ft.	SFR-Basic
05 126558 RK	R-7,200	Residential 7,200 sq. ft.	Single Family Res-Combo
05 122370 RK	R-7,200	Residential 7,200 sq. ft.	SFR-Basic
05 122371 RK	R-7,200	Residential 7,200 sq. ft.	SFR-Basic
05 122372 RK	R-7,200	Residential 7,200 sq. ft.	SFR-Basic
05 118325 RK	R-7,200	Residential 7,200 sq. ft.	Single Family Res-Combo
05 123091 RK	R-7,200	Residential 7,200 sq. ft.	Single Family Res-Combo
05 123251 RK	R-7,200	Residential 7,200 sq. ft.	Single Family Res-Combo
05 119759 RK	R-7,200	Residential 7,200 sq. ft.	Single Family Res-Combo
05 119755 RK	R-7,200	Residential 7,200 sq. ft.	Single Family Res-Combo
05 119758 RK	R-7,200	Residential 7,200 sq. ft.	Single Family Res-Combo
05 116407 RK	R-7,200	Residential 7,200 sq. ft.	Single Family Res-Combo
05 101210 RK	R-7,200	Residential 7,200 sq. ft.	Single Family Res-Combo
05 101211 RK	R-7,200	Residential 7,200 sq. ft.	Single Family Res-Combo
05 116484 RK	R-7,200	Residential 7,200 sq. ft.	Single Family Res-Combo
05 116486 RK	R-7,200	Residential 7,200 sq. ft.	Single Family Res-Combo
05 116487 RK	R-7,200	Residential 7,200 sq. ft.	Single Family Res-Combo
05 116489 RK	R-7,200	Residential 7,200 sq. ft.	Single Family Res-Combo
05 125742 RK	R-7,200	Residential 7,200 sq. ft.	Single Family Res-Combo
05 118159 RK	R-7,200	Residential 7,200 sq. ft.	Single Family Res-Combo
05 119045 RK	R-7,200	Residential 7,200 sq. ft.	Single Family Res-Combo
05 119522 RK	R-7,200	Residential 7,200 sq. ft.	Single Family Res-Combo
05 117530 RK	R-7,200	Residential 7,200 sq. ft.	Single Family Res-Combo
05 117526 RK	R-7,200	Residential 7,200 sq. ft.	Single Family Res-Combo
05 117527 RK	R-7,200	Residential 7,200 sq. ft.	Single Family Res-Combo
05 117528 RK	R-7,200	Residential 7,200 sq. ft.	Single Family Res-Combo
05 117442 RK	R-7,200	Residential 7,200 sq. ft.	Single Family Res-Combo
05 101238 RK	R-7,200	Residential 7,200 sq. ft.	Single Family Res-Combo
05 122301 RK	R-7,200	Residential 7,200 sq. ft.	Single Family Res-Combo
05 122367 RK	R-7,200	Residential 7,200 sq. ft.	SFR-Basic
05 122369 RK	R-7,200	Residential 7,200 sq. ft.	SFR-Basic
05 121670 RK	R-7,200	Residential 7,200 sq. ft.	Single Family Res-Combo
05 117064 RK	R-5	Rural-5 Acre	SFR-Basic
05 124154 RK	CITY	City	Single Family Res-Combo
05 121140 RK	R-7,200	Residential 7,200 sq. ft.	SFR-Basic
05 121536 RK	R-7,200	Residential 7,200 sq. ft.	Single Family Res-Combo
05 123486 RK	R-7,200	Residential 7,200 sq. ft.	Single Family Res-Combo
05 101990 RK	R-7,200	Residential 7,200 sq. ft.	Single Family Res-Combo
05 101208 RK	R-7,200	Residential 7,200 sq. ft.	Single Family Res-Combo

Accessory Dwelling Units

Index # - File Name: 1.0022 - Single Family Dwellings Data\_Snohomish County.pdf

05 100140 RK	R-7,200	Residential 7,200 sq. ft.	Single Family Res-Combo
05 100148 RK	R-7,200	Residential 7,200 sq. ft.	Single Family Res-Combo
05 123481 RK	R-7,200	Residential 7,200 sq. ft.	SFR-Basic
05 123482 RK	R-7,200	Residential 7,200 sq. ft.	SFR-Basic
05 100648 RK	R-7,200	Residential 7,200 sq. ft.	Single Family Res-Combo
05 100651 RK	R-7,200	Residential 7,200 sq. ft.	Single Family Res-Combo
05 100784 RK	R-7,200	Residential 7,200 sq. ft.	Single Family Res-Combo
05 100785 RK	R-7,200	Residential 7,200 sq. ft.	Single Family Res-Combo
05 124365 RK	R-7,200	Residential 7,200 sq. ft.	SFR-Basic
05 125354 RK	R-7,200	Residential 7,200 sq. ft.	SFR-Basic
05 124360 RK	R-7,200	Residential 7,200 sq. ft.	SFR-Basic
05 125357 RK	R-7,200	Residential 7,200 sq. ft.	SFR-Basic
05 125358 RK	R-7,200	Residential 7,200 sq. ft.	SFR-Basic
05 125362 RK	R-7,200	Residential 7,200 sq. ft.	SFR-Basic
05 121059 RK	R-5	Rural-5 Acre	Single Family Res-Combo
05 125325 RK	RRT-10	Rural Resource Transition-10	Accessory Apt Detached-Combo
05 100415 RK	CITY	City	SFR-Basic
04 118846 RK	CITY	City	SFR-Basic
05 100084 RK	CITY	City	SFR-Basic
05 117461 RK	CITY	City	SFR-Basic
05 117456 RK	CITY	City	SFR-Basic
05 116095 RK	CITY	City	SFR-Basic
05 117457 RK	CITY	City	SFR-Basic
05 116789 RK	CITY	City	SFR-Basic
05 116793 RK	CITY	City	SFR-Basic
05 100611 RK	CITY	City	SFR-Basic
05 117723 RK	CITY	City	SFR-Basic
04 120871 RK	CITY	City	SFR-Basic
04 120633 RK	CITY	City	SFR-Basic
05 101897 RK	CITY	City	SFR-Basic
05 101010 RK	CITY	City	SFR-Basic
05 101899 RK	CITY	City	SFR-Basic
05 116091 RK	CITY	City	SFR-Basic
05 116418 RK	CITY	City	SFR-Basic
05 116421 RK	CITY	City	SFR-Basic
05 116787 RK	CITY	City	SFR-Basic
05 117452 RK	CITY	City	SFR-Basic
05 117453 RK	CITY	City	SFR-Basic
05 117455 RK	CITY	City	SFR-Basic
05 100610 RK	CITY	City	SFR-Basic
05 100541 RK	CITY	City	SFR-Basic
04 120831 RK	CITY	City	SFR-Basic
04 120565 RK	CITY	City	SFR-Basic
04 120842 RK	CITY	City	SFR-Basic
05 100542 RK	CITY	City	SFR-Basic
04 120838 RK	CITY	City	SFR-Basic
04 120843 RK	CITY	City	SFR-Basic

Accessory Dwelling Units

Index # - File Name: 1.0022 - Single Family Dwellings Data\_Snohomish County.pdf

04 120568 RK	CITY	City	SFR-Basic
04 121230 RK	CITY	City	SFR-Basic
04 120557 RK	CITY	City	SFR-Basic
05 116507 RK	R-5	Rural-5 Acre	Single Family Res-Combo
05 124644 RK	R-5	Rural-5 Acre	Single Family Res-Combo
04 120114 RK	R-5	Rural-5 Acre	SFR-Basic
05 118149 RK	CITY	City	SFR-Basic
05 118150 RK	CITY	City	SFR-Basic
05 118152 RK	CITY	City	SFR-Basic
05 119872 RK	CITY	City	Single Family Res-Combo
05 119159 RK	CITY	City	SFR-Basic
05 119162 RK	CITY	City	SFR-Basic
05 120796 RK	CITY	City	Single Family Res-Combo
05 116047 RK	CITY	City	SFR-Basic
05 116046 RK	CITY	City	SFR-Basic
05 116044 RK	CITY	City	SFR-Basic
05 120434 RK	CITY	City	SFR-Basic
05 120436 RK	CITY	City	SFR-Basic
05 120437 RK	CITY	City	SFR-Basic
05 120510 RK	CITY	City	SFR-Basic
05 124452 RK	CITY	City	SFR-Basic
05 124455 RK	CITY	City	SFR-Basic
05 120797 RK	CITY	City	Single Family Res-Combo
05 122170 RK	CITY	City	SFR-Basic
05 117520 RK	CITY	City	SFR-Basic
05 117521 RK	CITY	City	SFR-Basic
05 117522 RK	CITY	City	SFR-Basic
05 121436 RK	CITY	City	Single Family Res-Combo
05 119164 RK	CITY	City	SFR-Basic
05 119165 RK	CITY	City	SFR-Basic
05 116221 RK	CITY	City	SFR-Basic
05 116218 RK	CITY	City	SFR-Basic
05 116225 RK	CITY	City	SFR-Basic
05 120144 RK	CITY	City	SFR-Basic
05 120147 RK	CITY	City	SFR-Basic
05 120148 RK	CITY	City	SFR-Basic
05 124456 RK	CITY	City	SFR-Basic
05 124457 RK	CITY	City	SFR-Basic
05 120044 RK	CITY	City	Single Family Res-Combo
05 119873 RK	CITY	City	Single Family Res-Combo
05 120546 RK	CITY	City	Single Family Res-Combo
05 120552 RK	CITY	City	Single Family Res-Combo
05 120555 RK	CITY	City	Single Family Res-Combo
05 120590 RK	CITY	City	Single Family Res-Combo
05 120591 RK	CITY	City	Single Family Res-Combo
05 120592 RK	CITY	City	Single Family Res-Combo
05 119875 RK	CITY	City	Duplex-Combo

Accessory Dwelling Units

Index # - File Name: 1.0022 - Single Family Dwellings Data\_Snohomish County.pdf

04 117607 MH	R-5	Rural-5 Acre	Double Wide
05 100409 RK	PRD-7,200	Residential 7,200 sq. ft.	SFR-Basic
05 122758 RK	R-5	Rural-5 Acre	Single Family Res-Combo
05 100407 RK	PRD-7,200	Residential 7,200 sq. ft.	SFR-Basic
05 100408 RK	PRD-7,200	Residential 7,200 sq. ft.	SFR-Basic
05 117122 RK	R-9,600	Residential 9,600 sq. ft.	SFR-Basic
05 102007 RK	R-9,600	Residential 9,600 sq. ft.	SFR-Basic
05 117774 RK	R-9,600	Residential 9,600 sq. ft.	SFR-Basic
04 118787 RK	R-9,600	Residential 9,600 sq. ft.	SFR-Basic
05 100655 RK	R-9,600	Residential 9,600 sq. ft.	SFR-Basic
04 121057 RK	LDMR	Low Density Multiple Reside	Single Family Res-Combo
04 121060 RK	LDMR	Low Density Multiple Reside	Single Family Res-Combo
05 102002 RK	R-9,600	Residential 9,600 sq. ft.	SFR-Basic
05 100012 RK	R-9,600	Residential 9,600 sq. ft.	SFR-Basic
05 117121 RK	R-9,600	Residential 9,600 sq. ft.	SFR-Basic
04 117015 RK	F	Forestry	Single Family Res-Combo
04 117060 RK	R-5	Rural-5 Acre	Single Family Res-Combo
05 122278 RK	R-5	Rural-5 Acre	Single Family Res-Combo
04 116446 RK	CITY	City	Single Family Res-Combo
04 119647 RK	R-5	Rural-5 Acre	Single Family Res-Combo
05 117117 RK	R-5	Rural-5 Acre	Single Family Res-Combo
05 122306 RK	R-5	Rural-5 Acre	SFR-Basic
05 101117 RK	R-5	Rural-5 Acre	Single Family Res-Combo
04 121316 RK	R-5	Rural-5 Acre	Single Family Res-Combo
05 121134 RK	R-5	Rural-5 Acre	SFR-Basic
05 122997 RK	R-5	Rural-5 Acre	SFR-Basic
05 123000 RK	R-5	Rural-5 Acre	SFR-Basic
05 123690 RK	R-5	Rural-5 Acre	SFR-Basic
05 116148 RK	R-5	Rural-5 Acre	Single Family Res-Combo
05 116148 001 00 RK	R-5	Rural-5 Acre	Single Family Res-Combo
05 116197 RK	R-5	Rural-5 Acre	Single Family Res-Combo
05 116202 RK	R-5	Rural-5 Acre	Single Family Res-Combo
05 116473 RK	R-5	Rural-5 Acre	Single Family Res-Combo
05 100174 RK	CITY	City	Single Family Res-Combo
05 119794 RK	R-5	Rural-5 Acre	Single Family Res-Combo
04 120940 RK	R-5	Rural-5 Acre	Single Family Res-Combo
04 121103 RK	R-5	Rural-5 Acre	Single Family Res-Combo
05 100537 RK	R-5	Rural-5 Acre	Single Family Res-Combo
05 120660 RK	R-5	Rural-5 Acre	Single Family Res-Combo
05 121214 RK	R-5	Rural-5 Acre	Single Family Res-Combo
05 118436 RK	R-5	Rural-5 Acre	Single Family Res-Combo
05 120094 RK	R-5	Rural-5 Acre	Single Family Res-Combo
05 120756 RK	R-5	Rural-5 Acre	Single Family Res-Combo
05 119788 RK	R-5	Rural-5 Acre	Single Family Res-Combo
05 118174 RK	R-5	Rural-5 Acre	Single Family Res-Combo
05 121215 RK	R-5	Rural-5 Acre	Single Family Res-Combo
05 118437 RK	R-5	Rural-5 Acre	Single Family Res-Combo

Accessory Dwelling Units

Index # - File Name: 1.0022 - Single Family Dwellings Data\_Snohomish County.pdf

05 116468 RK	R-5	Rural-5 Acre	Single Family Res-Combo
05 100569 RK	R-5	Rural-5 Acre	Single Family Res-Combo
04 121501 RK	CITY	City	SFR-Basic
04 121502 RK	CITY	City	SFR-Basic
04 121503 RK	CITY	City	SFR-Basic
04 121497 RK	CITY	City	SFR-Basic
04 121500 RK	CITY	City	SFR-Basic
04 121486 RK	CITY	City	SFR-Basic
04 121487 RK	CITY	City	SFR-Basic
04 121498 RK	CITY	City	SFR-Basic
04 121499 RK	CITY	City	SFR-Basic
04 116074 RK	RC	Rural Conservation	Single Family Res-Combo
04 121496 RK	CITY	City	SFR-Basic
05 100175 RK	CITY	City	Single Family Res-Combo
05 100173 RK	CITY	City	SFR-Basic
04 119148 RK	CITY	City	SFR-Basic
04 121571 RK	PRD-9,600	Residential 9,600 sq. ft.	SFR-Basic
05 119418 RK	R-5	Rural-5 Acre	Single Family Res-Combo
04 121328 RK	CITY	City	Single Family Res-Combo
04 117741 MH	R-5	Rural-5 Acre	
04 121331 RK	CITY	City	Single Family Res-Combo
04 121322 RK	CITY	City	Single Family Res-Combo
05 101225 RK	PRD-9,600	Residential 9,600 sq. ft.	Single Family Res-Combo
04 121586 RK	PRD-9,600	Residential 9,600 sq. ft.	Single Family Res-Combo
04 121528 RK	CITY	City	Single Family Res-Combo
04 121326 RK	CITY	City	Single Family Res-Combo
04 121320 RK	CITY	City	Single Family Res-Combo
04 121330 RK	CITY	City	Single Family Res-Combo
05 116472 RK	PRD-9,600	Residential 9,600 sq. ft.	SFR-Basic
05 121334 RK	PRD-9,600	Residential 9,600 sq. ft.	SFR-Basic
05 121332 RK	PRD-9,600	Residential 9,600 sq. ft.	SFR-Basic
05 116071 RK	PRD-9,600	Residential 9,600 sq. ft.	SFR-Basic
05 125284 RK	PRD-9,600	Residential 9,600 sq. ft.	SFR-Basic
04 120945 RK	CITY	City	Single Family Res-Combo
04 121038 RK	CITY	City	Single Family Res-Combo
04 121039 RK	CITY	City	Single Family Res-Combo
04 120263 RK	CITY	City	Single Family Res-Combo
04 121321 RK	CITY	City	Single Family Res-Combo
04 121324 RK	CITY	City	Single Family Res-Combo
05 116070 RK	PRD-9,600	Residential 9,600 sq. ft.	SFR-Basic
05 116075 RK	PRD-9,600	Residential 9,600 sq. ft.	SFR-Basic
04 115959 RK	PRD-9,600	Residential 9,600 sq. ft.	SFR-Basic
05 116074 RK	PRD-9,600	Residential 9,600 sq. ft.	SFR-Basic
05 116843 RK	PRD-9,600	Residential 9,600 sq. ft.	SFR-Basic
05 101227 RK	PRD-9,600	Residential 9,600 sq. ft.	Single Family Res-Combo
05 123101 RK	PRD-9,600	Residential 9,600 sq. ft.	SFR-Basic
05 100685 RK	PRD-9,600	Residential 9,600 sq. ft.	SFR-Basic



Accessory Dwelling Units

Index # - File Name: 1.0022 - Single Family Dwellings Data\_Snohomish County.pdf

04 121605 RK	PRD-9,600	Residential 9,600 sq. ft.	SFR-Basic
05 118391 RK	PRD-9,600	Residential 9,600 sq. ft.	SFR-Basic
05 123938 RK	PRD-9,600	Residential 9,600 sq. ft.	SFR-Basic
05 123940 RK	PRD-9,600	Residential 9,600 sq. ft.	SFR-Basic
04 121574 RK	PRD-9,600	Residential 9,600 sq. ft.	SFR-Basic
05 100682 RK	PRD-9,600	Residential 9,600 sq. ft.	SFR-Basic
04 121573 RK	PRD-9,600	Residential 9,600 sq. ft.	SFR-Basic
05 124248 RK	PRD-9,600	Residential 9,600 sq. ft.	SFR-Basic
05 101686 RK	PRD-9,600	Residential 9,600 sq. ft.	Single Family Res-Combo
04 121585 RK	PRD-9,600	Residential 9,600 sq. ft.	Single Family Res-Combo
05 123247 RK	PRD-9,600	Residential 9,600 sq. ft.	Single Family Res-Combo
04 118088 RK	PRD-9,600	Residential 9,600 sq. ft.	Single Family Res-Combo
05 119046 RK	PRD-9,600	Residential 9,600 sq. ft.	Single Family Res-Combo
05 120327 RK	PRD-9,600	Residential 9,600 sq. ft.	Single Family Res-Combo
05 123245 RK	PRD-9,600	Residential 9,600 sq. ft.	Single Family Res-Combo
05 121615 RK	PRD-9,600	Residential 9,600 sq. ft.	Single Family Res-Combo
05 123249 RK	PRD-9,600	Residential 9,600 sq. ft.	Single Family Res-Combo
05 116982 RK	PRD-9,600	Residential 9,600 sq. ft.	Single Family Res-Combo
05 116886 RK	PRD-9,600	Residential 9,600 sq. ft.	Single Family Res-Combo
05 101688 RK	PRD-9,600	Residential 9,600 sq. ft.	Single Family Res-Combo
05 100684 RK	PRD-9,600	Residential 9,600 sq. ft.	SFR-Basic
05 121581 RK	R-5	Rural-5 Acre	Single Family Res-Combo
05 100223 RK	R-9,600(PRD)	Residential 9,600 sq. ft.	SFR-Basic
05 125973 RK	PRD-9,600	Residential 9,600 sq. ft.	Single Family Res-Combo
05 125194 RK	PRD-9,600	Residential 9,600 sq. ft.	Single Family Res-Combo
05 125197 RK	PRD-9,600	Residential 9,600 sq. ft.	Single Family Res-Combo
05 125744 RK	PRD-9,600	Residential 9,600 sq. ft.	Single Family Res-Combo
05 127828 RK	PRD-9,600	Residential 9,600 sq. ft.	Single Family Res-Combo
05 126240 RK	PRD-9,600	Residential 9,600 sq. ft.	Single Family Res-Combo
04 121603 RK	PRD-9,600	Residential 9,600 sq. ft.	SFR-Basic
04 121604 RK	PRD-9,600	Residential 9,600 sq. ft.	SFR-Basic
05 124405 RK	PRD-9,600	Residential 9,600 sq. ft.	SFR-Basic
05 124406 RK	PRD-9,600	Residential 9,600 sq. ft.	SFR-Basic
05 124407 RK	PRD-9,600	Residential 9,600 sq. ft.	SFR-Basic
05 124409 RK	PRD-9,600	Residential 9,600 sq. ft.	SFR-Basic
05 124410 RK	PRD-9,600	Residential 9,600 sq. ft.	SFR-Basic
05 124411 RK	PRD-9,600	Residential 9,600 sq. ft.	SFR-Basic
05 124412 RK	PRD-9,600	Residential 9,600 sq. ft.	SFR-Basic
05 124421 RK	PRD-9,600	Residential 9,600 sq. ft.	SFR-Basic
05 124431 RK	PRD-9,600	Residential 9,600 sq. ft.	SFR-Basic
05 124432 RK	PRD-9,600	Residential 9,600 sq. ft.	SFR-Basic
05 124433 RK	PRD-9,600	Residential 9,600 sq. ft.	SFR-Basic
05 124434 RK	PRD-9,600	Residential 9,600 sq. ft.	SFR-Basic
05 124436 RK	PRD-9,600	Residential 9,600 sq. ft.	SFR-Basic
05 124437 RK	PRD-9,600	Residential 9,600 sq. ft.	SFR-Basic
05 123937 RK	PRD-9,600	Residential 9,600 sq. ft.	SFR-Basic
05 123967 RK	PRD-9,600	Residential 9,600 sq. ft.	SFR-Basic

Accessory Dwelling Units

Index # - File Name: 1.0022 - Single Family Dwellings Data\_Snohomish County.pdf

05 123970 RK	PRD-9,600	Residential 9,600 sq. ft.	SFR-Basic
05 123972 RK	PRD-9,600	Residential 9,600 sq. ft.	SFR-Basic
05 123974 RK	PRD-9,600	Residential 9,600 sq. ft.	SFR-Basic
04 121755 RK	PRD-9,600	Residential 9,600 sq. ft.	SFR-Basic
05 124404 RK	PRD-9,600	Residential 9,600 sq. ft.	SFR-Basic
05 116467 RK	R-7,200	Residential 7,200 sq. ft.	SFR-Basic
05 116469 RK	R-7,200	Residential 7,200 sq. ft.	SFR-Basic
05 116470 RK	R-7,200	Residential 7,200 sq. ft.	SFR-Basic
05 100161 RK	R-7,200	Residential 7,200 sq. ft.	SFR-Basic
05 116466 RK	R-7,200	Residential 7,200 sq. ft.	SFR-Basic
05 100162 RK	R-7,200	Residential 7,200 sq. ft.	SFR-Basic
05 100160 RK	R-7,200	Residential 7,200 sq. ft.	SFR-Basic
04 118947 RK	CITY	City	Single Family Res-Combo
05 100492 RK	R-9,600(PRD)	Residential 9,600 sq. ft.	SFR-Basic
05 100494 RK	R-9,600(PRD)	Residential 9,600 sq. ft.	SFR-Basic
05 100500 RK	R-9,600(PRD)	Residential 9,600 sq. ft.	SFR-Basic
05 100496 RK	R-9,600(PRD)	Residential 9,600 sq. ft.	SFR-Basic
05 100497 RK	R-9,600(PRD)	Residential 9,600 sq. ft.	SFR-Basic
05 100498 RK	R-9,600(PRD)	Residential 9,600 sq. ft.	SFR-Basic
05 100499 RK	R-9,600(PRD)	Residential 9,600 sq. ft.	SFR-Basic
05 101106 RK	R-9,600(PRD)	Residential 9,600 sq. ft.	SFR-Basic
05 101994 RK	R-9,600(PRD)	Residential 9,600 sq. ft.	SFR-Basic
05 101996 RK	R-9,600(PRD)	Residential 9,600 sq. ft.	SFR-Basic
05 101995 RK	R-9,600(PRD)	Residential 9,600 sq. ft.	SFR-Basic
05 117535 RK	R-9,600(PRD)	Residential 9,600 sq. ft.	SFR-Basic
05 101998 RK	R-9,600(PRD)	Residential 9,600 sq. ft.	SFR-Basic
05 117534 RK	R-9,600(PRD)	Residential 9,600 sq. ft.	SFR-Basic
05 102000 RK	R-9,600(PRD)	Residential 9,600 sq. ft.	SFR-Basic
05 116964 RK	R-9,600(PRD)	Residential 9,600 sq. ft.	SFR-Basic
05 116967 RK	R-9,600(PRD)	Residential 9,600 sq. ft.	SFR-Basic
05 119863 RK	R-9,600(PRD)	Residential 9,600 sq. ft.	SFR-Basic
05 119862 RK	R-9,600(PRD)	Residential 9,600 sq. ft.	SFR-Basic
04 121536 RK	R-9,600	Residential 9,600 sq. ft.	Single Family Res-Combo
05 116977 RK	R-9,600(PRD)	Residential 9,600 sq. ft.	SFR-Basic
05 116978 RK	R-9,600(PRD)	Residential 9,600 sq. ft.	SFR-Basic
05 117533 RK	R-9,600(PRD)	Residential 9,600 sq. ft.	SFR-Basic
05 116979 RK	R-9,600(PRD)	Residential 9,600 sq. ft.	SFR-Basic
05 101070 RK	R-9,600(PRD)	Residential 9,600 sq. ft.	SFR-Basic
05 116969 RK	R-9,600(PRD)	Residential 9,600 sq. ft.	SFR-Basic
05 116971 RK	R-9,600(PRD)	Residential 9,600 sq. ft.	SFR-Basic
05 116972 RK	R-9,600(PRD)	Residential 9,600 sq. ft.	SFR-Basic
05 116973 RK	R-9,600(PRD)	Residential 9,600 sq. ft.	SFR-Basic
05 116975 RK	R-9,600(PRD)	Residential 9,600 sq. ft.	SFR-Basic
05 100225 RK	R-9,600(PRD)	Residential 9,600 sq. ft.	SFR-Basic
05 100227 RK	R-9,600(PRD)	Residential 9,600 sq. ft.	SFR-Basic
04 121519 RK	R-9,600(PRD)	Residential 9,600 sq. ft.	SFR-Basic
05 100226 RK	R-9,600(PRD)	Residential 9,600 sq. ft.	SFR-Basic

Accessory Dwelling Units

Index # - File Name: 1.0022 - Single Family Dwellings Data\_Snohomish County.pdf

05 116231 RK	R-9,600(PRD)	Residential 9,600 sq. ft.	SFR-Basic
05 101858 RK	R-9,600(PRD)	Residential 9,600 sq. ft.	SFR-Basic
05 101859 RK	R-9,600(PRD)	Residential 9,600 sq. ft.	SFR-Basic
05 101860 RK	R-9,600(PRD)	Residential 9,600 sq. ft.	SFR-Basic
05 101861 RK	R-9,600(PRD)	Residential 9,600 sq. ft.	SFR-Basic
05 101862 RK	R-9,600(PRD)	Residential 9,600 sq. ft.	SFR-Basic
05 116217 RK	R-9,600(PRD)	Residential 9,600 sq. ft.	SFR-Basic
05 116219 RK	R-9,600(PRD)	Residential 9,600 sq. ft.	SFR-Basic
05 116220 RK	R-9,600(PRD)	Residential 9,600 sq. ft.	SFR-Basic
05 116223 RK	R-9,600(PRD)	Residential 9,600 sq. ft.	SFR-Basic
05 116224 RK	R-9,600(PRD)	Residential 9,600 sq. ft.	SFR-Basic
05 116226 RK	R-9,600(PRD)	Residential 9,600 sq. ft.	SFR-Basic
05 116227 RK	R-9,600(PRD)	Residential 9,600 sq. ft.	SFR-Basic
05 116228 RK	R-9,600(PRD)	Residential 9,600 sq. ft.	SFR-Basic
05 116229 RK	R-9,600(PRD)	Residential 9,600 sq. ft.	SFR-Basic
05 116230 RK	R-9,600(PRD)	Residential 9,600 sq. ft.	SFR-Basic
05 116984 RK	R-9,600(PRD)	Residential 9,600 sq. ft.	SFR-Basic
05 116983 RK	R-9,600(PRD)	Residential 9,600 sq. ft.	SFR-Basic
05 116985 RK	R-9,600(PRD)	Residential 9,600 sq. ft.	SFR-Basic
04 121538 RK	R-9,600	Residential 9,600 sq. ft.	Single Family Res-Combo
04 121333 RK	R-9,600	Residential 9,600 sq. ft.	Single Family Res-Combo
04 121329 RK	R-9,600	Residential 9,600 sq. ft.	Single Family Res-Combo
04 121336 RK	R-9,600	Residential 9,600 sq. ft.	Single Family Res-Combo
04 121332 RK	R-9,600	Residential 9,600 sq. ft.	Single Family Res-Combo
04 121532 RK	R-9,600	Residential 9,600 sq. ft.	Single Family Res-Combo
04 121533 RK	R-9,600	Residential 9,600 sq. ft.	Single Family Res-Combo
04 121041 RK	R-9,600	Residential 9,600 sq. ft.	Single Family Res-Combo
04 121043 RK	R-9,600	Residential 9,600 sq. ft.	Single Family Res-Combo
04 121046 RK	R-9,600	Residential 9,600 sq. ft.	Single Family Res-Combo
04 121042 RK	R-9,600	Residential 9,600 sq. ft.	Single Family Res-Combo
04 121325 RK	R-9,600	Residential 9,600 sq. ft.	Single Family Res-Combo
04 121327 RK	R-9,600	Residential 9,600 sq. ft.	Single Family Res-Combo
04 121545 RK	R-9,600	Residential 9,600 sq. ft.	Single Family Res-Combo
04 121544 RK	R-9,600	Residential 9,600 sq. ft.	Single Family Res-Combo
04 121542 RK	R-9,600	Residential 9,600 sq. ft.	Single Family Res-Combo
04 121534 RK	R-9,600	Residential 9,600 sq. ft.	Single Family Res-Combo
04 120939 RK	R-9,600	Residential 9,600 sq. ft.	Single Family Res-Combo
04 121540 RK	R-9,600	Residential 9,600 sq. ft.	Single Family Res-Combo
04 121541 RK	R-9,600	Residential 9,600 sq. ft.	Single Family Res-Combo
04 121275 RK	RC	Rural Conservation	Single Family Res-Combo
05 101042 RK	R-9,600	Residential 9,600 sq. ft.	SFR-Basic
05 101041 RK	R-9,600	Residential 9,600 sq. ft.	SFR-Basic
05 101236 RK	R-9,600	Residential 9,600 sq. ft.	Single Family Res-Combo
05 100657 RK	R-9,600	Residential 9,600 sq. ft.	SFR-Basic
04 117173 RK	R-9,600	Residential 9,600 sq. ft.	SFR-Basic
05 119761 RK	R-9,600	Residential 9,600 sq. ft.	Single Family Res-Combo
05 120080 RK	R-9,600	Residential 9,600 sq. ft.	Single Family Res-Combo

Accessory Dwelling Units

Index # - File Name: 1.0022 - Single Family Dwellings Data\_Snohomish County.pdf

05 101884 RK	R-9,600	Residential 9,600 sq. ft.	Single Family Res-Combo
05 100950 RK	R-9,600	Residential 9,600 sq. ft.	Single Family Res-Combo
04 118749 RK	R-9,600	Residential 9,600 sq. ft.	Single Family Res-Combo
05 101235 RK	R-9,600	Residential 9,600 sq. ft.	Single Family Res-Combo
05 117441 RK	R-9,600	Residential 9,600 sq. ft.	Single Family Res-Combo
05 119524 RK	R-9,600	Residential 9,600 sq. ft.	Single Family Res-Combo
05 118321 RK	R-9,600	Residential 9,600 sq. ft.	Single Family Res-Combo
05 119523 RK	R-9,600	Residential 9,600 sq. ft.	Single Family Res-Combo
05 118413 RK	R-9,600	Residential 9,600 sq. ft.	Single Family Res-Combo
05 121481 RK	R-9,600	Residential 9,600 sq. ft.	Single Family Res-Combo
05 118784 RK	R-9,600	Residential 9,600 sq. ft.	Single Family Res-Combo
05 124241 RK	R-9,600	Residential 9,600 sq. ft.	Single Family Res-Combo
05 121048 RK	R-9,600	Residential 9,600 sq. ft.	Single Family Res-Combo
05 100485 RK	R-9,600	Residential 9,600 sq. ft.	Single Family Res-Combo
05 125547 RK	R-9,600	Residential 9,600 sq. ft.	Single Family Res-Combo
05 125545 RK	R-9,600	Residential 9,600 sq. ft.	Single Family Res-Combo
05 122316 RK	RRT-10	Rural Resource Transition-1(SFR-Basic	
05 122104 RK	RRT-10	Rural Resource Transition-1(SFR-Basic	
05 122106 RK	RRT-10	Rural Resource Transition-1(SFR-Basic	
05 123501 RK	RRT-10	Rural Resource Transition-1(SFR-Basic	
05 122942 RK	RRT-10	Rural Resource Transition-1(SFR-Basic	
05 123222 RK	RRT-10	Rural Resource Transition-1(Single Family Res-Combo	
05 124370 RK	R-9,600	Residential 9,600 sq. ft.	Single Family Res-Combo
05 123948 RK	R-9,600	Residential 9,600 sq. ft.	Single Family Res-Combo
05 128097 RK	R-9,600	Residential 9,600 sq. ft.	Single Family Res-Combo
05 102037 RK	R-5	Rural-5 Acre	Single Family Res-Combo
05 116606 RK	R-5	Rural-5 Acre	SFR-Basic
05 122102 RK	RRT-10	Rural Resource Transition-1(SFR-Basic	
05 122317 RK	RRT-10	Rural Resource Transition-1(SFR-Basic	
05 102042 RK	R-5	Rural-5 Acre	Single Family Res-Combo
05 100176 RK	R-5	Rural-5 Acre	Single Family Res-Combo
04 121477 RK	R-5	Rural-5 Acre	Single Family Res-Combo
05 117719 RK	R-5	Rural-5 Acre	Single Family Res-Combo
05 118065 RK	R-5	Rural-5 Acre	Single Family Res-Combo
04 115312 RK	R-5	Rural-5 Acre	Single Family Res-Combo
05 116944 RK	R-5	Rural-5 Acre	Single Family Res-Combo
05 117944 RK	R-5	Rural-5 Acre	Single Family Res-Combo
05 116357 RK	R-7,200	Residential 7,200 sq. ft.	Single Family Res-Combo
05 101670 RK	R-7,200	Residential 7,200 sq. ft.	Single Family Res-Combo
05 119857 RK	R-7,200	Residential 7,200 sq. ft.	Single Family Res-Combo
05 123643 RK	R-5	Rural-5 Acre	Single Family Res-Combo
05 101842 RK	R-5	Rural-5 Acre	SFR-Basic
05 100748 RK	R-5	Rural-5 Acre	SFR-Basic
05 100745 RK	R-5	Rural-5 Acre	SFR-Basic
05 100743 RK	R-5	Rural-5 Acre	SFR-Basic
05 101305 RK	R-5	Rural-5 Acre	SFR-Basic
05 117032 RK	R-5	Rural-5 Acre	Single Family Res-Combo

Accessory Dwelling Units

Index # - File Name: 1.0022 - Single Family Dwellings Data\_Snohomish County.pdf

04 114762 RK	R-5	Rural-5 Acre	SFR-Basic
05 126850 RK	R-5	Rural-5 Acre	Single Family Res-Combo
05 100742 RK	R-5	Rural-5 Acre	SFR-Basic
05 100751 RK	R-5	Rural-5 Acre	SFR-Basic
05 100378 RK	R-5	Rural-5 Acre	Single Family Res-Combo
05 101848 RK	R-5	Rural-5 Acre	SFR-Basic
05 118163 RK	R-5	Rural-5 Acre	Single Family Res-Combo
05 100746 RK	R-5	Rural-5 Acre	SFR-Basic
05 100749 RK	R-5	Rural-5 Acre	SFR-Basic
05 100741 RK	R-5	Rural-5 Acre	SFR-Basic
05 126245 RK	R-5	Rural-5 Acre	SFR-Basic
05 125235 RK	R-5	Rural-5 Acre	SFR-Basic
05 123480 RK	R-5	Rural-5 Acre	SFR-Basic
05 119839 RK	R-5	Rural-5 Acre	Single Family Res-Combo
05 119840 RK	R-5	Rural-5 Acre	Single Family Res-Combo
05 119843 RK	R-5	Rural-5 Acre	Single Family Res-Combo
05 117252 RK	R-5	Rural-5 Acre	Single Family Res-Combo
05 117289 RK	R-5	Rural-5 Acre	Single Family Res-Combo
05 118953 RK	CITY	City	SFR-Basic
05 118954 RK	CITY	City	SFR-Basic
05 118955 RK	CITY	City	SFR-Basic
05 118956 RK	CITY	City	SFR-Basic
05 118957 RK	CITY	City	SFR-Basic
05 118958 RK	CITY	City	SFR-Basic
05 118959 RK	CITY	City	SFR-Basic
05 118960 RK	CITY	City	SFR-Basic
05 117040 RK	LDMR	Low Density Multiple Reside	SFR-Basic
05 118019 RK	LDMR	Low Density Multiple Reside	SFR-Basic
05 118033 RK	LDMR	Low Density Multiple Reside	SFR-Basic
05 118047 RK	LDMR	Low Density Multiple Reside	SFR-Basic
05 118054 RK	LDMR	Low Density Multiple Reside	SFR-Basic
05 117039 RK	LDMR	Low Density Multiple Reside	SFR-Basic
05 117250 RK	R-7,200	Residential 7,200 sq. ft.	Single Family Res-Combo
05 123401 RK	R-9,600	Residential 9,600 sq. ft.	Single Family Res-Combo
05 117662 RK	R-5	Rural-5 Acre	Single Family Res-Combo
05 117826 RK	F	Forestry	Single Family Res-Combo
05 122180 RK	LDMR	Low Density Multiple Reside	SFR-Basic
05 119864 RK	LDMR	Low Density Multiple Reside	SFR-Basic
05 119868 RK	LDMR	Low Density Multiple Reside	SFR-Basic
05 119869 RK	LDMR	Low Density Multiple Reside	SFR-Basic
05 119870 RK	LDMR	Low Density Multiple Reside	SFR-Basic
05 120650 RK	LDMR	Low Density Multiple Reside	SFR-Basic
05 120647 RK	LDMR	Low Density Multiple Reside	SFR-Basic
05 121230 RK	LDMR	Low Density Multiple Reside	SFR-Basic
05 121231 RK	LDMR	Low Density Multiple Reside	SFR-Basic
05 121232 RK	LDMR	Low Density Multiple Reside	SFR-Basic
05 121233 RK	LDMR	Low Density Multiple Reside	SFR-Basic

Accessory Dwelling Units

Index # - File Name: 1.0022 - Single Family Dwellings Data\_Snohomish County.pdf

05 121234 RK	LDMR	Low Density Multiple Reside	SFR-Basic
05 122181 RK	LDMR	Low Density Multiple Reside	SFR-Basic
05 122182 RK	LDMR	Low Density Multiple Reside	SFR-Basic
05 122183 RK	LDMR	Low Density Multiple Reside	SFR-Basic
05 122184 RK	LDMR	Low Density Multiple Reside	SFR-Basic
05 123729 RK	LDMR	Low Density Multiple Reside	SFR-Basic
05 123731 RK	LDMR	Low Density Multiple Reside	SFR-Basic
05 123732 RK	LDMR	Low Density Multiple Reside	SFR-Basic
05 123735 RK	LDMR	Low Density Multiple Reside	SFR-Basic
05 123736 RK	LDMR	Low Density Multiple Reside	SFR-Basic
05 123733 RK	LDMR	Low Density Multiple Reside	SFR-Basic
05 124960 RK	LDMR	Low Density Multiple Reside	SFR-Basic
05 124958 RK	LDMR	Low Density Multiple Reside	SFR-Basic
05 121710 RK	CITY	City	SFR-Basic
05 121711 RK	CITY	City	SFR-Basic
05 120227 RK	CITY	City	SFR-Basic
05 121712 RK	CITY	City	SFR-Basic
05 120230 RK	CITY	City	SFR-Basic
05 121713 RK	CITY	City	SFR-Basic
05 121714 RK	CITY	City	SFR-Basic
05 116806 RK	R-5	Rural-5 Acre	Single Family Res-Combo
05 116949 RK	R-5	Rural-5 Acre	Single Family Res-Combo
05 123965 RK	R-5	Rural-5 Acre	Single Family Res-Combo
05 120679 RK	CITY	City	SFR-Basic
05 123422 RK	CITY	City	SFR-Basic
05 120154 RK	CITY	City	Single Family Res-Combo
05 120151 RK	CITY	City	Single Family Res-Combo
05 119765 RK	R-5	Rural-5 Acre	Single Family Res-Combo
05 119773 RK	R-5	Rural-5 Acre	Single Family Res-Combo
05 120672 RK	R-5	Rural-5 Acre	Single Family Res-Combo
05 120388 RK	R-5	Rural-5 Acre	Single Family Res-Combo
05 119771 RK	R-5	Rural-5 Acre	Single Family Res-Combo
05 119648 RK	R-5	Rural-5 Acre	Single Family Res-Combo
05 119653 RK	R-5	Rural-5 Acre	Single Family Res-Combo
05 122705 RK	R-5	Rural-5 Acre	Single Family Res-Combo
05 125570 RK	R-5	Rural-5 Acre	Single Family Res-Combo
05 122234 RK	R-5	Rural-5 Acre	Single Family Res-Combo
05 128146 RK	CITY	City	SFR-Basic
05 128145 RK	CITY	City	SFR-Basic
05 119775 RK			SFR-Basic
05 119207 RK			SFR-Basic
05 119776 RK	R-7,200	Residential 7,200 sq. ft.	SFR-Basic
05 119778 RK			SFR-Basic
05 119779 RK			SFR-Basic
05 116072 RK			Single Family Res-Combo
05 119797 RK	CITY	City	SFR-Basic
05 119542 RK	CITY	City	SFR-Basic

Accessory Dwelling Units

Index # - File Name: 1.0022 - Single Family Dwellings Data\_Snohomish County.pdf

05 120090 RK	CITY	City	SFR-Basic
05 119535 RK	CITY	City	SFR-Basic
05 120541 RK	CITY	City	SFR-Basic
05 120542 RK	CITY	City	SFR-Basic
05 122887 RK	R-5	Rural-5 Acre	Single Family Res-Combo
05 122893 RK	R-5	Rural-5 Acre	Single Family Res-Combo
05 124650 RK	R-5	Rural-5 Acre	Single Family Res-Combo
05 119762 RK	R-5	Rural-5 Acre	Single Family Res-Combo
05 121807 RK	CITY	City	SFR-Basic
05 123513 RK	CITY	City	SFR-Basic
05 123515 RK	CITY	City	SFR-Basic
05 121496 RK	CITY	City	SFR-Basic
05 121498 RK	CITY	City	SFR-Basic
05 120841 RK	CITY	City	SFR-Basic
05 120845 RK	CITY	City	SFR-Basic
05 124840 RK	CITY	City	SFR-Basic
05 123746 RK	CITY	City	SFR-Basic
05 121090 RK	CITY	City	SFR-Basic
05 121093 RK	CITY	City	SFR-Basic
05 121089 RK	CITY	City	SFR-Basic
05 121499 RK	CITY	City	SFR-Basic
05 120269 RK	CITY	City	SFR-Basic
05 120270 RK	CITY	City	SFR-Basic
05 121500 RK	CITY	City	SFR-Basic
05 121808 RK	CITY	City	SFR-Basic
05 121810 RK	CITY	City	SFR-Basic
05 123516 RK	CITY	City	SFR-Basic
05 123741 RK	CITY	City	SFR-Basic
05 129088 RK	CITY	City	SFR-Basic
05 122985 RK	CITY	City	SFR-Basic
05 122986 RK	CITY	City	SFR-Basic
05 123744 RK	CITY	City	SFR-Basic
05 123518 RK	CITY	City	SFR-Basic
05 125638 RK	CITY	City	SFR-Basic
05 124392 RK	CITY	City	SFR-Basic
05 123743 RK	CITY	City	SFR-Basic
05 122207 RK	CITY	City	SFR-Basic
05 122206 RK	CITY	City	SFR-Basic
05 123742 RK	CITY	City	SFR-Basic
05 122319 MH	R-5	Rural-5 Acre	Double Wide
05 123089 RK	R-5	Rural-5 Acre	Single Family Res-Combo
05 124843 RK	CITY	City	SFR-Basic
05 123519 RK	CITY	City	SFR-Basic
05 123521 RK	CITY	City	SFR-Basic
05 124390 RK	CITY	City	Single Family Res-Combo
05 120853 RK	CITY	City	SFR-Basic
05 125280 RK	CITY	City	Single Family Res-Combo

Accessory Dwelling Units

Index # - File Name: 1.0022 - Single Family Dwellings Data\_Snohomish County.pdf

05 125666 RK	R-5	Rural-5 Acre	Single Family Res-Combo
05 128064 RK	CITY	City	SFR-Basic
05 125640 RK	CITY	City	SFR-Basic
05 124152 RK	CITY	City	SFR-Basic
05 124150 RK	CITY	City	SFR-Basic
05 123522 RK	CITY	City	SFR-Basic
05 122987 RK	CITY	City	SFR-Basic
05 122984 RK	CITY	City	SFR-Basic
05 120272 RK	CITY	City	SFR-Basic
05 120273 RK	CITY	City	SFR-Basic
05 129090 RK	CITY	City	SFR-Basic
05 126577 RK	CITY	City	SFR-Basic
05 128850 RK	CITY	City	SFR-Basic
05 124839 RK	CITY	City	SFR-Basic
05 126576 RK	CITY	City	SFR-Basic
05 124282 RK	R-5	Rural-5 Acre	SFR-Basic
05 124283 RK	R-5	Rural-5 Acre	SFR-Basic
05 121804 RK	R-5	Rural-5 Acre	SFR-Basic
05 121805 RK	R-5	Rural-5 Acre	SFR-Basic
05 123471 RK	R-5	Rural-5 Acre	SFR-Basic
05 125637 RK	R-5	Rural-5 Acre	Single Family Res-Combo
05 121802 RK	R-5	Rural-5 Acre	SFR-Basic
05 121803 RK	R-5	Rural-5 Acre	SFR-Basic
05 121502 RK	CITY	City	SFR-Basic
05 121503 RK	CITY	City	SFR-Basic
05 121084 RK	CITY	City	SFR-Basic
05 121085 RK	CITY	City	SFR-Basic
05 121086 RK	CITY	City	SFR-Basic
05 120091 RK	CITY	City	SFR-Basic
05 123508 RK	CITY	City	SFR-Basic
05 123509 RK	CITY	City	SFR-Basic
05 125880 RK	CITY	City	SFR-Basic
05 121806 RK	CITY	City	SFR-Basic
05 122510 RK	CITY	City	SFR-Basic
05 122511 RK	CITY	City	SFR-Basic
05 123511 RK	CITY	City	SFR-Basic
05 122989 RK	CITY	City	SFR-Basic
05 122990 RK	CITY	City	SFR-Basic
05 122988 RK	CITY	City	SFR-Basic
05 124387 RK	CITY	City	SFR-Basic
05 123747 RK	CITY	City	SFR-Basic
05 119784 RK	CITY	City	SFR-Basic
05 123751 RK	CITY	City	SFR-Basic
05 123507 RK	CITY	City	Single Family Res-Combo
05 119785 RK	CITY	City	SFR-Basic
05 119787 RK	CITY	City	SFR-Basic
05 119541 RK	CITY	City	SFR-Basic



Accessory Dwelling Units

Index # - File Name: 1.0022 - Single Family Dwellings Data\_Snohomish County.pdf

05 119736 RK	CITY	City	SFR-Basic
05 119789 RK	CITY	City	SFR-Basic
05 119790 RK	CITY	City	SFR-Basic
05 119792 RK	CITY	City	SFR-Basic
05 123231 RK	CITY	City	SFR-Basic
05 121505 RK	CITY	City	SFR-Basic
05 123512 RK	CITY	City	SFR-Basic
05 120276 RK	CITY	City	SFR-Basic
05 121087 RK	CITY	City	SFR-Basic
05 122205 RK	CITY	City	SFR-Basic
05 125879 RK	CITY	City	SFR-Basic
05 120543 RK	CITY	City	SFR-Basic
05 120275 RK	CITY	City	SFR-Basic
05 128526 RK	CITY	City	SFR-Basic
05 129089 RK	CITY	City	SFR-Basic
05 127787 RK	CITY	City	SFR-Basic
05 121198 RK	CITY	City	SFR-Basic
05 127763 RK	CITY	City	SFR-Basic
05 126096 RK	CITY	City	SFR-Basic
05 124642 RK	CITY	City	SFR-Basic
05 124643 RK	CITY	City	SFR-Basic
05 121197 RK	CITY	City	SFR-Basic
05 127767 RK	CITY	City	SFR-Basic
05 120709 RK	R-7,200	Residential 7,200 sq. ft.	SFR-Basic
05 119662 RK	R-7,200	Residential 7,200 sq. ft.	SFR-Basic
05 120711 RK	R-7,200	Residential 7,200 sq. ft.	SFR-Basic
05 120714 RK	R-7,200	Residential 7,200 sq. ft.	SFR-Basic
05 120710 RK	R-7,200	Residential 7,200 sq. ft.	SFR-Basic
05 123679 RK	R-7,200	Residential 7,200 sq. ft.	SFR-Basic
05 120705 RK	R-7,200	Residential 7,200 sq. ft.	SFR-Basic
05 128828 RK	R-7,200	Residential 7,200 sq. ft.	SFR-Basic
05 120718 RK	R-7,200	Residential 7,200 sq. ft.	Single Family Res-Combo
05 120719 RK	R-7,200	Residential 7,200 sq. ft.	Single Family Res-Combo
05 121483 RK	R-7,200	Residential 7,200 sq. ft.	SFR-Basic
05 121489 RK	R-7,200	Residential 7,200 sq. ft.	Single Family Res-Combo
05 123672 RK	R-7,200	Residential 7,200 sq. ft.	SFR-Basic
05 121768 RK	R-7,200	Residential 7,200 sq. ft.	Single Family Res-Combo
05 121764 RK	R-7,200	Residential 7,200 sq. ft.	Single Family Res-Combo
05 121762 RK	R-7,200	Residential 7,200 sq. ft.	Single Family Res-Combo
05 123720 RK	R-7,200	Residential 7,200 sq. ft.	Single Family Res-Combo
05 121533 RK	R-7,200	Residential 7,200 sq. ft.	Single Family Res-Combo
05 122318 RK	R-7,200	Residential 7,200 sq. ft.	Single Family Res-Combo
05 121529 RK	R-7,200	Residential 7,200 sq. ft.	SFR-Basic
05 123723 RK	R-7,200	Residential 7,200 sq. ft.	Single Family Res-Combo
05 121528 RK	R-7,200	Residential 7,200 sq. ft.	SFR-Basic
05 126601 RK	R-7,200	Residential 7,200 sq. ft.	Single Family Res-Combo
05 125271 RK	R-7,200	Residential 7,200 sq. ft.	SFR-Basic

Accessory Dwelling Units

Index # - File Name: 1.0022 - Single Family Dwellings Data\_Snohomish County.pdf

05 122320 RK	R-7,200	Residential 7,200 sq. ft.	Single Family Res-Combo
05 126350 RK	R-7,200	Residential 7,200 sq. ft.	SFR-Basic
05 124823 RK	R-7,200	Residential 7,200 sq. ft.	Single Family Res-Combo
05 121001 RK	R-7,200	Residential 7,200 sq. ft.	SFR-Basic
05 124824 RK	R-7,200	Residential 7,200 sq. ft.	SFR-Basic
05 124825 RK	R-7,200	Residential 7,200 sq. ft.	SFR-Basic
05 121012 RK	R-7,200	Residential 7,200 sq. ft.	SFR-Basic
05 124826 RK	R-7,200	Residential 7,200 sq. ft.	SFR-Basic
05 121013 RK	R-7,200	Residential 7,200 sq. ft.	SFR-Basic
05 124828 RK	R-7,200	Residential 7,200 sq. ft.	SFR-Basic
05 121005 RK	R-7,200	Residential 7,200 sq. ft.	SFR-Basic
05 121009 RK	R-7,200	Residential 7,200 sq. ft.	SFR-Basic
05 121202 RK	R-7,200	Residential 7,200 sq. ft.	Single Family Res-Combo
05 120738 RK	R-7,200	Residential 7,200 sq. ft.	Single Family Res-Combo
05 120741 RK	R-7,200	Residential 7,200 sq. ft.	Single Family Res-Combo
05 120742 RK	R-7,200	Residential 7,200 sq. ft.	Single Family Res-Combo
05 120745 RK	R-7,200	Residential 7,200 sq. ft.	Single Family Res-Combo
05 121203 RK	R-7,200	Residential 7,200 sq. ft.	Single Family Res-Combo
05 121204 RK	R-7,200	Residential 7,200 sq. ft.	Single Family Res-Combo
05 121205 RK	R-7,200	Residential 7,200 sq. ft.	Single Family Res-Combo
05 126040 RK	F	Forestry	Single Family Res-Combo
05 122792 RK	R-9,600	Residential 9,600 sq. ft.	SFR-Basic
05 122793 RK	R-9,600	Residential 9,600 sq. ft.	SFR-Basic
05 122794 RK	R-9,600	Residential 9,600 sq. ft.	SFR-Basic
05 122795 RK	R-9,600	Residential 9,600 sq. ft.	SFR-Basic
05 122797 RK	R-9,600	Residential 9,600 sq. ft.	Single Family Res-Combo
05 122798 RK	R-9,600	Residential 9,600 sq. ft.	SFR-Basic
05 124251 RK	R-9,600	Residential 9,600 sq. ft.	SFR-Basic
05 124252 RK	R-9,600	Residential 9,600 sq. ft.	SFR-Basic
05 124253 RK	R-9,600	Residential 9,600 sq. ft.	SFR-Basic
05 124254 RK	R-9,600	Residential 9,600 sq. ft.	SFR-Basic
05 126031 RK	R-9,600	Residential 9,600 sq. ft.	SFR-Basic
05 126029 RK	R-9,600	Residential 9,600 sq. ft.	SFR-Basic
05 120824 RK	CITY	City	SFR-Basic
05 123069 RK	CITY	City	SFR-Basic
05 123074 RK	CITY	City	SFR-Basic
05 121032 RK	CITY	City	SFR-Basic
05 125507 RK	CITY	City	SFR-Basic
05 125509 RK	CITY	City	SFR-Basic
05 125508 RK	CITY	City	SFR-Basic
05 121488 RK	R-7,200	Residential 7,200 sq. ft.	Single Family Res-Combo
05 120123 RK	R-7,200	Residential 7,200 sq. ft.	Single Family Res-Combo
05 120128 RK	R-7,200	Residential 7,200 sq. ft.	Single Family Res-Combo
05 120717 RK	R-7,200	Residential 7,200 sq. ft.	SFR-Basic
05 126605 RK	R-9,600	Residential 9,600 sq. ft.	SFR-Basic
05 121321 RK	R-9,600	Residential 9,600 sq. ft.	SFR-Basic
05 127953 RK	R-9,600	Residential 9,600 sq. ft.	SFR-Basic

Accessory Dwelling Units

Index # - File Name: 1.0022 - Single Family Dwellings Data\_Snohomish County.pdf

05 127954 RK	R-9,600	Residential 9,600 sq. ft.	SFR-Basic
05 122469 RK	R-9,600	Residential 9,600 sq. ft.	SFR-Basic
05 122470 RK	R-9,600	Residential 9,600 sq. ft.	SFR-Basic
05 122471 RK	R-9,600	Residential 9,600 sq. ft.	SFR-Basic
05 122472 RK	R-9,600	Residential 9,600 sq. ft.	SFR-Basic
05 122473 RK	R-9,600	Residential 9,600 sq. ft.	SFR-Basic
05 122474 RK	R-9,600	Residential 9,600 sq. ft.	SFR-Basic
05 122476 RK	R-9,600	Residential 9,600 sq. ft.	SFR-Basic
05 121308 RK	R-9,600	Residential 9,600 sq. ft.	SFR-Basic
05 121307 RK	R-9,600	Residential 9,600 sq. ft.	SFR-Basic
05 124678 RK	R-9,600	Residential 9,600 sq. ft.	SFR-Basic
05 121310 RK	R-9,600	Residential 9,600 sq. ft.	SFR-Basic
05 121311 RK	R-9,600	Residential 9,600 sq. ft.	SFR-Basic
05 121312 RK	R-9,600	Residential 9,600 sq. ft.	SFR-Basic
05 121313 RK	R-9,600	Residential 9,600 sq. ft.	SFR-Basic
05 121314 RK	R-9,600	Residential 9,600 sq. ft.	SFR-Basic
05 121315 RK	R-9,600	Residential 9,600 sq. ft.	SFR-Basic
05 121316 RK	R-9,600	Residential 9,600 sq. ft.	SFR-Basic
05 121317 RK	R-9,600	Residential 9,600 sq. ft.	SFR-Basic
05 121318 RK	R-9,600	Residential 9,600 sq. ft.	SFR-Basic
05 121319 RK	R-9,600	Residential 9,600 sq. ft.	SFR-Basic
05 124680 RK	R-9,600	Residential 9,600 sq. ft.	SFR-Basic
05 121723 RK	R-9,600	Residential 9,600 sq. ft.	SFR-Basic
05 121722 RK	R-9,600	Residential 9,600 sq. ft.	SFR-Basic
05 121720 RK	R-9,600	Residential 9,600 sq. ft.	SFR-Basic
05 121719 RK	R-9,600	Residential 9,600 sq. ft.	SFR-Basic
05 121718 RK	R-9,600	Residential 9,600 sq. ft.	SFR-Basic
05 121717 RK	R-9,600	Residential 9,600 sq. ft.	SFR-Basic
05 121716 RK	R-9,600	Residential 9,600 sq. ft.	SFR-Basic
05 123760 RK	R-9,600	Residential 9,600 sq. ft.	SFR-Basic
05 126041 RK	R-9,600	Residential 9,600 sq. ft.	SFR-Basic
05 123435 RK	R-9,600	Residential 9,600 sq. ft.	SFR-Basic
05 123437 RK	R-9,600	Residential 9,600 sq. ft.	SFR-Basic
05 126047 RK	R-9,600	Residential 9,600 sq. ft.	SFR-Basic
05 121320 RK	R-9,600	Residential 9,600 sq. ft.	SFR-Basic
05 124688 RK	R-9,600	Residential 9,600 sq. ft.	SFR-Basic
05 124687 RK	R-9,600	Residential 9,600 sq. ft.	SFR-Basic
05 122477 RK	R-9,600	Residential 9,600 sq. ft.	SFR-Basic
05 124683 RK	R-9,600	Residential 9,600 sq. ft.	Single Family Res-Combo
05 120028 RK	LDMR	Low Density Multiple Reside	SFR-Basic
05 119233 RK	LDMR	Low Density Multiple Reside	SFR-Basic
05 125329 RK	LDMR	Low Density Multiple Reside	SFR-Basic
05 125330 RK	LDMR	Low Density Multiple Reside	SFR-Basic
05 125332 RK	LDMR	Low Density Multiple Reside	SFR-Basic
05 125333 RK	LDMR	Low Density Multiple Reside	SFR-Basic
05 121818 RK	LDMR	Low Density Multiple Reside	SFR-Basic
05 125327 RK	LDMR	Low Density Multiple Reside	SFR-Basic

Accessory Dwelling Units

Index # - File Name: 1.0022 - Single Family Dwellings Data\_Snohomish County.pdf

05 120791 RK	LDMR	Low Density Multiple Reside SFR-Basic
05 121820 RK	LDMR	Low Density Multiple Reside SFR-Basic
05 121821 RK	LDMR	Low Density Multiple Reside SFR-Basic
05 120790 RK	LDMR	Low Density Multiple Reside SFR-Basic
05 121349 RK	LDMR	Low Density Multiple Reside SFR-Basic
05 121822 RK	LDMR	Low Density Multiple Reside SFR-Basic
05 121823 RK	LDMR	Low Density Multiple Reside SFR-Basic
05 121350 RK	LDMR	Low Density Multiple Reside SFR-Basic
05 120445 RK	LDMR	Low Density Multiple Reside SFR-Basic
05 120443 RK	LDMR	Low Density Multiple Reside SFR-Basic
05 120792 RK	LDMR	Low Density Multiple Reside SFR-Basic
05 119234 RK	LDMR	Low Density Multiple Reside SFR-Basic
05 121352 RK	LDMR	Low Density Multiple Reside SFR-Basic
05 119235 RK	LDMR	Low Density Multiple Reside SFR-Basic
05 120446 RK	LDMR	Low Density Multiple Reside SFR-Basic
05 121353 RK	LDMR	Low Density Multiple Reside SFR-Basic
05 120447 RK	LDMR	Low Density Multiple Reside SFR-Basic
05 120448 RK	LDMR	Low Density Multiple Reside SFR-Basic
05 120029 RK	LDMR	Low Density Multiple Reside SFR-Basic
05 119232 RK	LDMR	Low Density Multiple Reside SFR-Basic
05 121824 RK	LDMR	Low Density Multiple Reside SFR-Basic
05 120036 RK	LDMR	Low Density Multiple Reside SFR-Basic
05 119231 RK	LDMR	Low Density Multiple Reside SFR-Basic
05 120037 RK	LDMR	Low Density Multiple Reside SFR-Basic
05 121354 RK	LDMR	Low Density Multiple Reside SFR-Basic
05 120038 RK	LDMR	Low Density Multiple Reside SFR-Basic
05 120442 RK	LDMR	Low Density Multiple Reside SFR-Basic
05 121825 RK	LDMR	Low Density Multiple Reside SFR-Basic
05 121355 RK	LDMR	Low Density Multiple Reside SFR-Basic
05 121356 RK	LDMR	Low Density Multiple Reside SFR-Basic
05 120441 RK	LDMR	Low Density Multiple Reside SFR-Basic
05 121826 RK	LDMR	Low Density Multiple Reside SFR-Basic
05 121827 RK	LDMR	Low Density Multiple Reside SFR-Basic
05 120793 RK	LDMR	Low Density Multiple Reside SFR-Basic
05 121828 RK	LDMR	Low Density Multiple Reside SFR-Basic
05 121831 RK	LDMR	Low Density Multiple Reside SFR-Basic
05 120786 RK	LDMR	Low Density Multiple Reside SFR-Basic
05 120788 RK	LDMR	Low Density Multiple Reside SFR-Basic
05 120794 RK	LDMR	Low Density Multiple Reside SFR-Basic
05 120039 RK	LDMR	Low Density Multiple Reside SFR-Basic
05 120041 RK	LDMR	Low Density Multiple Reside SFR-Basic
05 121832 RK	LDMR	Low Density Multiple Reside SFR-Basic
05 120040 RK	LDMR	Low Density Multiple Reside SFR-Basic
05 121358 RK	LDMR	Low Density Multiple Reside SFR-Basic
05 119236 RK	LDMR	Low Density Multiple Reside SFR-Basic
05 121381 RK	CITY	City SFR-Basic
05 121383 RK	CITY	City SFR-Basic

Accessory Dwelling Units

Index # - File Name: 1.0022 - Single Family Dwellings Data\_Snohomish County.pdf

05 121384 RK	CITY	City	SFR-Basic
05 121385 RK	CITY	City	SFR-Basic
05 122696 RK	CITY	City	SFR-Basic
05 123283 RK	CITY	City	SFR-Basic
05 123284 RK	CITY	City	SFR-Basic
05 123285 RK	CITY	City	SFR-Basic
05 123286 RK	CITY	City	SFR-Basic
05 124416 RK	CITY	City	SFR-Basic
05 124418 RK	CITY	City	SFR-Basic
05 123288 RK	CITY	City	SFR-Basic
05 123289 RK	CITY	City	SFR-Basic
05 123291 RK	CITY	City	SFR-Basic
05 124419 RK	CITY	City	SFR-Basic
05 120316 RK	CITY	City	SFR-Basic
05 120315 RK	CITY	City	SFR-Basic
05 120309 RK	CITY	City	SFR-Basic
05 120313 RK	CITY	City	SFR-Basic
05 120317 RK	CITY	City	SFR-Basic
05 120311 RK	CITY	City	SFR-Basic
05 120305 RK	CITY	City	SFR-Basic
05 120324 RK	CITY	City	SFR-Basic
05 120322 RK	CITY	City	SFR-Basic
05 120314 RK	CITY	City	SFR-Basic
05 120306 RK	CITY	City	SFR-Basic
05 120321 RK	CITY	City	SFR-Basic
05 120323 RK	CITY	City	SFR-Basic
05 120318 RK	CITY	City	SFR-Basic
05 120307 RK	CITY	City	SFR-Basic
05 120320 RK	CITY	City	SFR-Basic
05 121386 RK	CITY	City	SFR-Basic
05 121387 RK	CITY	City	SFR-Basic
05 121388 RK	CITY	City	SFR-Basic
05 121390 RK	CITY	City	SFR-Basic
05 121391 RK	CITY	City	SFR-Basic
05 121392 RK	CITY	City	SFR-Basic
05 121393 RK	CITY	City	SFR-Basic
05 121394 RK	CITY	City	SFR-Basic
05 121395 RK	CITY	City	SFR-Basic
05 121397 RK	CITY	City	SFR-Basic
05 122558 RK	CITY	City	SFR-Basic
05 122557 RK	CITY	City	SFR-Basic
05 122555 RK	CITY	City	SFR-Basic
05 122554 RK	CITY	City	SFR-Basic
05 122553 RK	CITY	City	SFR-Basic
05 122551 RK	CITY	City	SFR-Basic
05 122550 RK	CITY	City	SFR-Basic
05 123292 RK	CITY	City	SFR-Basic

Accessory Dwelling Units

Index # - File Name: 1.0022 - Single Family Dwellings Data\_Snohomish County.pdf

05 123293 RK	CITY	City	SFR-Basic
05 127304 RK	R-5	Rural-5 Acre	SFR-Basic
05 121583 RK	R-5	Rural-5 Acre	Single Family Res-Combo
05 119192 RK	R-5	Rural-5 Acre	Single Family Res-Combo
05 121585 RK	R-5	Rural-5 Acre	Single Family Res-Combo
05 119195 RK	R-5	Rural-5 Acre	Single Family Res-Combo
05 121587 RK	R-5	Rural-5 Acre	Single Family Res-Combo
05 120535 RK	R-5	Rural-5 Acre	Single Family Res-Combo
05 120173 RK	R-5	Rural-5 Acre	SFR-Basic
05 127305 RK	R-5	Rural-5 Acre	SFR-Basic
05 120174 RK	R-5	Rural-5 Acre	SFR-Basic
05 120538 RK	R-5	Rural-5 Acre	Single Family Res-Combo
05 124300 RK	R-5	Rural-5 Acre	SFR-Basic
05 119569 RK	R-5	Rural-5 Acre	Duplex-Basic
05 119570 RK	R-5	Rural-5 Acre	Duplex-Basic
05 119670 RK	R-5	Rural-5 Acre	Single Family Res-Combo
05 119672 RK	R-5	Rural-5 Acre	Single Family Res-Combo
05 123452 RK	R-9,600	Residential 9,600 sq. ft.	Single Family Res-Combo
05 120332 RK	R-9,600	Residential 9,600 sq. ft.	Single Family Res-Combo
05 121162 RK	R-5	Rural-5 Acre	SFR-Basic
05 120419 RK	R-5	Rural-5 Acre	Single Family Res-Combo
05 120423 RK	R-5	Rural-5 Acre	SFR-Basic
05 121158 RK	R-5	Rural-5 Acre	SFR-Basic
05 120424 RK	R-5	Rural-5 Acre	SFR-Basic
05 120425 RK	R-5	Rural-5 Acre	SFR-Basic
05 121160 RK	R-5	Rural-5 Acre	SFR-Basic
05 121166 RK	R-5	Rural-5 Acre	SFR-Basic
05 121161 RK	R-5	Rural-5 Acre	SFR-Basic
05 121165 RK	R-5	Rural-5 Acre	SFR-Basic
05 102031 RK	R-5	Rural-5 Acre	Single Family Res-Combo
05 123038 RK	R-5	Rural-5 Acre	Single Family Res-Combo
05 123027 RK	R-5	Rural-5 Acre	Single Family Res-Combo
05 122241 RK	R-5	Rural-5 Acre	SFR-Basic
05 121904 RK	R-5	Rural-5 Acre	SFR-Basic
05 121906 RK	R-5	Rural-5 Acre	SFR-Basic
05 123329 RK	R-5	Rural-5 Acre	SFR-Basic
05 123322 RK	R-5	Rural-5 Acre	SFR-Basic
05 123326 RK	R-5	Rural-5 Acre	SFR-Basic
05 123541 RK	R-5	Rural-5 Acre	SFR-Basic
05 121375 RK	R-5	Rural-5 Acre	SFR-Basic
05 122923 RK	R-5	Rural-5 Acre	SFR-Basic
05 120479 RK	R-5	Rural-5 Acre	Single Family Res-Combo
05 120520 RK	WFB	Waterfront Beach	Single Family Res-Combo
05 121114 RK	CITY	City	SFR-Basic
05 121210 RK	CITY	City	SFR-Basic
05 121206 RK	CITY	City	SFR-Basic
05 120698 RK	CITY	City	SFR-Basic

Accessory Dwelling Units

Index # - File Name: 1.0022 - Single Family Dwellings Data\_Snohomish County.pdf

05 123754 RK	CITY	City	SFR-Basic
05 123755 RK	CITY	City	SFR-Basic
05 125992 RK	CITY	City	SFR-Basic
05 124212 RK	CITY	City	SFR-Basic
05 124216 RK	CITY	City	SFR-Basic
05 125651 RK	CITY	City	SFR-Basic
05 121708 RK	CITY	City	Duplex-Basic
05 121724 RK	CITY	City	Duplex-Basic
05 125948 RK	CITY	City	SFR-Basic
05 126224 RK	CITY	City	SFR-Basic
05 125660 RK	CITY	City	SFR-Basic
05 125656 RK	CITY	City	SFR-Basic
05 127717 RK	CITY	City	SFR-Basic
05 124218 RK	CITY	City	SFR-Basic
05 125953 RK	CITY	City	Duplex-Basic
05 122078 RK	CITY	City	SFR-Basic
05 125347 RK	CITY	City	SFR-Basic
05 122082 RK	CITY	City	SFR-Basic
05 125990 RK	CITY	City	SFR-Basic
05 125243 RK	CITY	City	SFR-Basic
05 123757 RK	CITY	City	SFR-Basic
05 123758 RK	CITY	City	SFR-Basic
05 120653 RK	WFB	Waterfront Beach	Single Family Res-Combo
05 120192 RK	WFB	Waterfront Beach	Single Family Res-Combo
05 119836 MH	R-12,500	Residential 12,500 sq. ft.	Double Wide
05 126603 RK	R-9,600	Residential 9,600 sq. ft.	SFR-Basic
05 120401 RK	MR	Multiple Residential	Single Family Res-Combo
05 120974 RK	R-5	Rural-5 Acre	Single Family Res-Combo
05 121035 RK	R-5	Rural-5 Acre	Single Family Res-Combo
05 121044 RK	R-5	Rural-5 Acre	Single Family Res-Combo
05 121351 RK	R-5	Rural-5 Acre	Single Family Res-Combo
05 120995 RK	LDMR	Low Density Multiple Reside	Single Family Res-Combo
05 121642 RK	R-5	Rural-5 Acre	Single Family Res-Combo
05 121273 RK	R-5	Rural-5 Acre	Single Family Res-Combo
05 119874 RK	R-5	Rural-5 Acre	Single Family Res-Combo
05 121484 MH	RD	Rural Diversification	Double Wide
05 121507 RK	R-5	Rural-5 Acre	Single Family Res-Combo
05 121789 RK	RD	Rural Diversification	Single Family Res-Combo
05 123601 RK	RRT-10	Rural Resource Transition-10	Single Family Res-Combo
05 123605 RK	RRT-10	Rural Resource Transition-10	Single Family Res-Combo
05 127983 RK	RRT-10	Rural Resource Transition-10	Single Family Res-Combo
05 122697 RK	R-7,200	Residential 7,200 sq. ft.	SFR-Basic
05 122698 RK	R-7,200	Residential 7,200 sq. ft.	SFR-Basic
05 122699 RK	R-7,200	Residential 7,200 sq. ft.	SFR-Basic
05 122700 RK	R-7,200	Residential 7,200 sq. ft.	SFR-Basic
05 122701 RK	R-7,200	Residential 7,200 sq. ft.	SFR-Basic
05 122702 RK	R-7,200	Residential 7,200 sq. ft.	SFR-Basic

Accessory Dwelling Units

Index # - File Name: 1.0022 - Single Family Dwellings Data\_Snohomish County.pdf

05 122703 RK	R-7,200	Residential 7,200 sq. ft.	SFR-Basic
05 122704 RK	R-7,200	Residential 7,200 sq. ft.	SFR-Basic
05 124414 RK	R-7,200	Residential 7,200 sq. ft.	SFR-Basic
05 122721 RK	R-7,200	Residential 7,200 sq. ft.	SFR-Basic
05 122723 RK	R-7,200	Residential 7,200 sq. ft.	SFR-Basic
05 128575 RK	R-7,200	Residential 7,200 sq. ft.	SFR-Basic
05 128576 RK	R-7,200	Residential 7,200 sq. ft.	SFR-Basic
05 128577 RK	R-7,200	Residential 7,200 sq. ft.	SFR-Basic
05 128578 RK	R-7,200	Residential 7,200 sq. ft.	SFR-Basic
05 128579 RK	R-7,200	Residential 7,200 sq. ft.	SFR-Basic
05 128580 RK	R-7,200	Residential 7,200 sq. ft.	SFR-Basic
05 128581 RK	R-7,200	Residential 7,200 sq. ft.	SFR-Basic
05 127463 RK	R-7,200	Residential 7,200 sq. ft.	SFR-Basic
05 127460 RK	R-7,200	Residential 7,200 sq. ft.	SFR-Basic
05 127462 RK	R-7,200	Residential 7,200 sq. ft.	SFR-Basic
05 127459 RK	R-7,200	Residential 7,200 sq. ft.	SFR-Basic
05 127461 RK	R-7,200	Residential 7,200 sq. ft.	SFR-Basic
05 127457 RK	R-7,200	Residential 7,200 sq. ft.	SFR-Basic
05 127458 RK	R-7,200	Residential 7,200 sq. ft.	SFR-Basic
05 124874 RK	R-7,200	Residential 7,200 sq. ft.	SFR-Basic
05 124875 RK	R-7,200	Residential 7,200 sq. ft.	SFR-Basic
05 124876 RK	R-7,200	Residential 7,200 sq. ft.	SFR-Basic
05 124877 RK	R-7,200	Residential 7,200 sq. ft.	SFR-Basic
05 124878 RK	R-7,200	Residential 7,200 sq. ft.	SFR-Basic
05 124879 RK	R-7,200	Residential 7,200 sq. ft.	SFR-Basic
05 123536 RK	R-7,200	Residential 7,200 sq. ft.	SFR-Basic
05 123537 RK	R-7,200	Residential 7,200 sq. ft.	SFR-Basic
05 123538 RK	R-7,200	Residential 7,200 sq. ft.	SFR-Basic
05 123539 RK	R-7,200	Residential 7,200 sq. ft.	SFR-Basic
05 123540 RK	R-7,200	Residential 7,200 sq. ft.	SFR-Basic
05 123006 RK	R-7,200	Residential 7,200 sq. ft.	SFR-Basic
05 122725 RK	R-7,200	Residential 7,200 sq. ft.	SFR-Basic
05 122726 RK	R-7,200	Residential 7,200 sq. ft.	SFR-Basic
05 122727 RK	R-7,200	Residential 7,200 sq. ft.	SFR-Basic
05 122720 RK	R-7,200	Residential 7,200 sq. ft.	SFR-Basic
05 122728 RK	R-7,200	Residential 7,200 sq. ft.	SFR-Basic
05 122729 RK	R-7,200	Residential 7,200 sq. ft.	SFR-Basic
05 122730 RK	R-7,200	Residential 7,200 sq. ft.	SFR-Basic
05 124888 RK	R-7,200	Residential 7,200 sq. ft.	SFR-Basic
05 126172 RK	R-7,200	Residential 7,200 sq. ft.	SFR-Basic
05 126198 RK	R-7,200	Residential 7,200 sq. ft.	SFR-Basic
05 126173 RK	R-7,200	Residential 7,200 sq. ft.	SFR-Basic
05 126192 RK	R-7,200	Residential 7,200 sq. ft.	SFR-Basic
05 126392 RK	R-7,200	Residential 7,200 sq. ft.	SFR-Basic
05 126174 RK	R-7,200	Residential 7,200 sq. ft.	SFR-Basic
05 126190 RK	R-7,200	Residential 7,200 sq. ft.	SFR-Basic
05 122281 RK	R-5	Rural-5 Acre	Single Family Res-Combo



Accessory Dwelling Units

Index # - File Name: 1.0022 - Single Family Dwellings Data\_Snohomish County.pdf

05 122020 RK	R-5	Rural-5 Acre	Single Family Res-Combo
05 125070 RK	R-7,200	Residential 7,200 sq. ft.	SFR-Basic
05 125063 RK	R-7,200	Residential 7,200 sq. ft.	SFR-Basic
05 125073 RK	R-7,200	Residential 7,200 sq. ft.	SFR-Basic
05 126458 RK	R-7,200	Residential 7,200 sq. ft.	Single Family Res-Combo
05 125069 RK	R-7,200	Residential 7,200 sq. ft.	SFR-Basic
05 125068 RK	R-7,200	Residential 7,200 sq. ft.	SFR-Basic
05 125065 RK	R-7,200	Residential 7,200 sq. ft.	SFR-Basic
05 125072 RK	R-7,200	Residential 7,200 sq. ft.	SFR-Basic
05 125071 RK	R-7,200	Residential 7,200 sq. ft.	SFR-Basic
05 124895 RK	R-7,200	Residential 7,200 sq. ft.	SFR-Basic
05 126460 RK	R-7,200	Residential 7,200 sq. ft.	Single Family Res-Combo
05 125067 RK	R-7,200	Residential 7,200 sq. ft.	SFR-Basic
05 125064 RK	R-7,200	Residential 7,200 sq. ft.	SFR-Basic
05 125066 RK	R-7,200	Residential 7,200 sq. ft.	SFR-Basic
05 127805 RK	R-7,200	Residential 7,200 sq. ft.	SFR-Basic
05 127806 RK	R-7,200	Residential 7,200 sq. ft.	SFR-Basic
05 127813 RK	R-7,200	Residential 7,200 sq. ft.	SFR-Basic
05 127814 RK	R-7,200	Residential 7,200 sq. ft.	SFR-Basic
05 127816 RK	R-7,200	Residential 7,200 sq. ft.	SFR-Basic
05 127817 RK	R-7,200	Residential 7,200 sq. ft.	SFR-Basic
05 126966 RK	RRT-10	Rural Resource Transition-1	Single Family Res-Combo
05 126539 RK	RRT-10	Rural Resource Transition-1	Single Family Res-Combo
05 127819 RK	R-7,200	Residential 7,200 sq. ft.	SFR-Basic
05 127822 RK	R-7,200	Residential 7,200 sq. ft.	SFR-Basic
05 127820 RK	R-7,200	Residential 7,200 sq. ft.	SFR-Basic
05 122174 RK	LDMR	Low Density Multiple Reside	Duplex-Combo
05 123684 RK	R-5	Rural-5 Acre	Single Family Res-Combo
05 122765 RK	R-7,200	Residential 7,200 sq. ft.	Single Family Res-Combo
05 123591 RK	R-7,200	Residential 7,200 sq. ft.	SFR-Basic
05 123593 RK	R-7,200	Residential 7,200 sq. ft.	SFR-Basic
05 123596 RK	R-7,200	Residential 7,200 sq. ft.	SFR-Basic
05 123594 RK	R-7,200	Residential 7,200 sq. ft.	SFR-Basic
05 123759 RK	R-7,200	Residential 7,200 sq. ft.	SFR-Basic
05 123055 RK	R-5	Rural-5 Acre	Single Family Res-Combo
05 128021 RK	R-7,200(PRD)	Residential 7,200 sq. ft.	SFR-Basic
05 128020 RK	R-7,200(PRD)	Residential 7,200 sq. ft.	SFR-Basic
05 128022 RK	R-7,200(PRD)	Residential 7,200 sq. ft.	SFR-Basic
05 128023 RK	R-7,200(PRD)	Residential 7,200 sq. ft.	SFR-Basic
05 128024 RK	R-7,200(PRD)	Residential 7,200 sq. ft.	SFR-Basic
05 128025 RK	R-7,200(PRD)	Residential 7,200 sq. ft.	SFR-Basic
05 128026 RK	R-7,200(PRD)	Residential 7,200 sq. ft.	SFR-Basic
05 128027 RK	R-7,200(PRD)	Residential 7,200 sq. ft.	SFR-Basic
05 128028 RK	R-7,200(PRD)	Residential 7,200 sq. ft.	SFR-Basic
05 128029 RK	R-7,200(PRD)	Residential 7,200 sq. ft.	SFR-Basic
05 128506 RK	R-7,200(PRD)	Residential 7,200 sq. ft.	SFR-Basic
05 124648 RK	RRT-10	Rural Resource Transition-1	Single Family Res-Combo

Accessory Dwelling Units

Index # - File Name: 1.0022 - Single Family Dwellings Data\_Snohomish County.pdf

05 124801 RK	R-5	Rural-5 Acre	Single Family Res-Combo
05 128031 RK	R-7,200(PRD)	Residential 7,200 sq. ft.	SFR-Basic
05 128032 RK	R-7,200(PRD)	Residential 7,200 sq. ft.	SFR-Basic
05 128033 RK	R-7,200(PRD)	Residential 7,200 sq. ft.	SFR-Basic
05 128034 RK	R-7,200(PRD)	Residential 7,200 sq. ft.	SFR-Basic
05 128035 RK	R-7,200(PRD)	Residential 7,200 sq. ft.	SFR-Basic
05 128036 RK	R-7,200(PRD)	Residential 7,200 sq. ft.	SFR-Basic
05 128037 RK	R-7,200(PRD)	Residential 7,200 sq. ft.	SFR-Basic
05 128038 RK	R-7,200(PRD)	Residential 7,200 sq. ft.	SFR-Basic
05 128039 RK	R-7,200(PRD)	Residential 7,200 sq. ft.	SFR-Basic
05 128040 RK	R-7,200(PRD)	Residential 7,200 sq. ft.	SFR-Basic
05 128041 RK	R-7,200(PRD)	Residential 7,200 sq. ft.	SFR-Basic
05 128043 RK	R-7,200(PRD)	Residential 7,200 sq. ft.	SFR-Basic
05 128044 RK	R-7,200(PRD)	Residential 7,200 sq. ft.	SFR-Basic
05 128045 RK	R-7,200(PRD)	Residential 7,200 sq. ft.	SFR-Basic
05 128046 RK	R-7,200(PRD)	Residential 7,200 sq. ft.	SFR-Basic
05 128047 RK	R-7,200(PRD)	Residential 7,200 sq. ft.	SFR-Basic
05 128048 RK	R-7,200(PRD)	Residential 7,200 sq. ft.	SFR-Basic
05 124816 RK	CITY	City	SFR-Basic
05 122481 RK	R-7,200	Residential 7,200 sq. ft.	SFR-Basic
05 122900 RK	MR	Multiple Residential	Single Family Res-Combo
05 122263 RK	MR	Multiple Residential	Single Family Res-Combo
05 126253 RK	MR	Multiple Residential	Single Family Res-Combo
05 124977 RK	MR	Multiple Residential	Single Family Res-Combo
05 126254 RK	MR	Multiple Residential	Single Family Res-Combo
05 126257 RK	MR	Multiple Residential	Single Family Res-Combo
05 122848 MH	R-5	Rural-5 Acre	Double Wide
05 122830 RK	MR	Multiple Residential	SFR-Basic
05 123706 RK	R-5	Rural-5 Acre	Single Family Res-Combo
05 124435 RK	MR	Multiple Residential	SFR-Basic
05 123063 RK	MR	Multiple Residential	SFR-Basic
05 124438 RK	MR	Multiple Residential	SFR-Basic
05 125512 RK	MR	Multiple Residential	SFR-Basic
05 126448 RK	MR	Multiple Residential	SFR-Basic
05 127568 RK	MR	Multiple Residential	SFR-Basic
05 127234 RK	MR	Multiple Residential	SFR-Basic
05 127235 RK	MR	Multiple Residential	SFR-Basic
05 122828 RK	MR	Multiple Residential	SFR-Basic
05 128842 RK	MR	Multiple Residential	SFR-Basic
05 129276 RK	MR	Multiple Residential	SFR-Basic
05 129277 RK	MR	Multiple Residential	SFR-Basic
05 124788 RK	R-7,200	Residential 7,200 sq. ft.	SFR-Basic
05 123559 RK	R-7,200	Residential 7,200 sq. ft.	SFR-Basic
05 123557 RK	R-7,200	Residential 7,200 sq. ft.	SFR-Basic
05 125544 RK	R-7,200	Residential 7,200 sq. ft.	SFR-Basic
05 125546 RK	R-7,200	Residential 7,200 sq. ft.	SFR-Basic
05 127428 RK	R-7,200	Residential 7,200 sq. ft.	SFR-Basic

Accessory Dwelling Units

Index # - File Name: 1.0022 - Single Family Dwellings Data\_Snohomish County.pdf

05 124785 RK	R-7,200	Residential 7,200 sq. ft.	SFR-Basic
05 127427 RK	R-7,200	Residential 7,200 sq. ft.	SFR-Basic
05 124325 RK	R-7,200	Residential 7,200 sq. ft.	SFR-Basic
05 125540 RK	R-7,200	Residential 7,200 sq. ft.	SFR-Basic
05 125542 RK	R-7,200	Residential 7,200 sq. ft.	SFR-Basic
05 125541 RK	R-7,200	Residential 7,200 sq. ft.	SFR-Basic
05 125543 RK	R-7,200	Residential 7,200 sq. ft.	SFR-Basic
05 123560 RK	R-7,200	Residential 7,200 sq. ft.	SFR-Basic
05 123558 RK	R-7,200	Residential 7,200 sq. ft.	SFR-Basic
05 123561 RK	R-7,200	Residential 7,200 sq. ft.	SFR-Basic
05 124787 RK	R-7,200	Residential 7,200 sq. ft.	SFR-Basic
05 124789 RK	R-7,200	Residential 7,200 sq. ft.	SFR-Basic
05 123966 RK	R-7,200	Residential 7,200 sq. ft.	SFR-Basic
05 124784 RK	R-7,200	Residential 7,200 sq. ft.	SFR-Basic
05 126579 RK	R-7,200	Residential 7,200 sq. ft.	SFR-Basic
05 127426 RK	R-7,200	Residential 7,200 sq. ft.	SFR-Basic
05 128845 RK	MR	Multiple Residential	SFR-Basic
05 122832 RK	MR	Multiple Residential	SFR-Basic
05 127570 RK	MR	Multiple Residential	SFR-Basic
05 126449 RK	MR	Multiple Residential	SFR-Basic
05 125510 RK	MR	Multiple Residential	SFR-Basic
05 122743 MH	R-5	Rural-5 Acre	Double Wide
05 123037 RK	R-5	Rural-5 Acre	Single Family Res-Combo
05 123795 RK	MR	Multiple Residential	Single Family Res-Combo
05 122262 RK	MR	Multiple Residential	Single Family Res-Combo
05 124129 RK	R-5	Rural-5 Acre	Single Family Res-Combo
05 129319 RK	R-7,200	Residential 7,200 sq. ft.	SFR-Basic
05 125400 RK	R-7,200	Residential 7,200 sq. ft.	Single Family Res-Combo
05 125395 RK	R-7,200	Residential 7,200 sq. ft.	SFR-Basic
05 125951 RK	R-7,200	Residential 7,200 sq. ft.	Single Family Res-Combo
05 125396 RK	R-7,200	Residential 7,200 sq. ft.	SFR-Basic
05 127850 RK	LDMR	Low Density Multiple Reside	SFR-Basic
05 127290 RK	LDMR	Low Density Multiple Reside	SFR-Basic
05 125404 RK	LDMR	Low Density Multiple Reside	SFR-Basic
05 125406 RK	LDMR	Low Density Multiple Reside	SFR-Basic
05 127292 RK	LDMR	Low Density Multiple Reside	SFR-Basic
05 127769 RK	LDMR	Low Density Multiple Reside	SFR-Basic
05 127772 RK	LDMR	Low Density Multiple Reside	SFR-Basic
05 126097 RK	LDMR	Low Density Multiple Reside	SFR-Basic
05 127773 RK	LDMR	Low Density Multiple Reside	SFR-Basic
05 124693 RK	LDMR	Low Density Multiple Reside	SFR-Basic
05 126100 RK	LDMR	Low Density Multiple Reside	SFR-Basic
05 123409 RK	LDMR	Low Density Multiple Reside	SFR-Basic
05 126482 RK	LDMR	Low Density Multiple Reside	SFR-Basic
05 123408 RK	LDMR	Low Density Multiple Reside	SFR-Basic
05 126602 RK	LDMR	Low Density Multiple Reside	SFR-Basic
05 125407 RK	LDMR	Low Density Multiple Reside	SFR-Basic

Accessory Dwelling Units

Index # - File Name: 1.0022 - Single Family Dwellings Data\_Snohomish County.pdf

05 123730 RK	LDMR	Low Density Multiple Reside SFR-Basic
05 126485 RK	LDMR	Low Density Multiple Reside SFR-Basic
05 125740 RK	LDMR	Low Density Multiple Reside SFR-Basic
05 125741 RK	LDMR	Low Density Multiple Reside SFR-Basic
05 126487 RK	LDMR	Low Density Multiple Reside SFR-Basic
05 125739 RK	LDMR	Low Density Multiple Reside SFR-Basic
05 126489 RK	LDMR	Low Density Multiple Reside SFR-Basic
05 125743 RK	LDMR	Low Density Multiple Reside SFR-Basic
05 123407 RK	LDMR	Low Density Multiple Reside SFR-Basic
05 126490 RK	LDMR	Low Density Multiple Reside SFR-Basic
05 123734 RK	LDMR	Low Density Multiple Reside SFR-Basic
05 125746 RK	LDMR	Low Density Multiple Reside SFR-Basic
04 115415 001 00 RK	A-10 : R-5	Agriculture-10 Acre : Rural-5 Single Family Res-Combo
04 115415 002 00 RK	A-10 : R-5	Agriculture-10 Acre : Rural-5 Single Family Res-Combo
05 123412 RK	R-5	Rural-5 Acre Single Family Res-Combo
05 123960 RK	LDMR	Low Density Multiple Reside SFR-Basic
05 124690 RK	LDMR	Low Density Multiple Reside SFR-Basic
05 123962 RK	LDMR	Low Density Multiple Reside SFR-Basic
05 126103 RK	LDMR	Low Density Multiple Reside SFR-Basic
05 127851 RK	LDMR	Low Density Multiple Reside SFR-Basic
05 123469 RK	R-5	Rural-5 Acre Single Family Res-Combo
05 127849 RK	LDMR	Low Density Multiple Reside SFR-Basic
05 123700 RK	R-5	Rural-5 Acre Single Family Res-Combo
05 123664 RK	R-5	Rural-5 Acre Single Family Res-Combo
05 123756 RK	R-5	Rural-5 Acre Single Family Res-Combo
05 123800 RK	R-5	Rural-5 Acre Single Family Res-Combo
05 123925 RK	MR	Multiple Residential SFR-Basic
05 124296 RK	R-5	Rural-5 Acre Single Family Res-Combo
05 124312 RK	R-5	Rural-5 Acre SFR-Basic
05 124384 RK	R-5	Rural-5 Acre SFR-Basic
05 127104 RK	CITY	City SFR-Basic
05 127094 RK	CITY	City SFR-Basic
05 127105 RK	CITY	City SFR-Basic
05 125654 RK	CITY	City SFR-Basic
05 128072 RK	R-7,200	Residential 7,200 sq. ft. SFR-Basic
05 124422 RK	R-7,200	Residential 7,200 sq. ft. Single Family Res-Combo
05 125306 RK	R-7,200	Residential 7,200 sq. ft. SFR-Basic
05 125315 RK	R-7,200	Residential 7,200 sq. ft. SFR-Basic
05 125309 RK	R-7,200	Residential 7,200 sq. ft. Single Family Res-Combo
05 127780 RK	R-7,200	Residential 7,200 sq. ft. SFR-Basic
05 127781 RK	R-7,200	Residential 7,200 sq. ft. SFR-Basic
05 128613 RK	R-7,200	Residential 7,200 sq. ft. SFR-Basic
05 127432 RK	R-7,200	Residential 7,200 sq. ft. SFR-Basic
05 128854 RK	R-7,200	Residential 7,200 sq. ft. SFR-Basic
05 128177 RK	R-7,200	Residential 7,200 sq. ft. SFR-Basic
05 126124 RK	R-7,200	Residential 7,200 sq. ft. SFR-Basic
05 126974 RK	R-7,200	Residential 7,200 sq. ft. SFR-Basic

Accessory Dwelling Units

Index # - File Name: 1.0022 - Single Family Dwellings Data\_Snohomish County.pdf

05 126338 RK	R-7,200	Residential 7,200 sq. ft.	SFR-Basic
05 128175 RK	R-7,200	Residential 7,200 sq. ft.	SFR-Basic
05 126580 RK	R-7,200	Residential 7,200 sq. ft.	SFR-Basic
05 126976 RK	R-7,200	Residential 7,200 sq. ft.	SFR-Basic
05 126336 RK	R-7,200	Residential 7,200 sq. ft.	SFR-Basic
05 127431 RK	R-7,200	Residential 7,200 sq. ft.	SFR-Basic
05 126125 RK	R-7,200	Residential 7,200 sq. ft.	SFR-Basic
05 127832 RK	R-7,200	Residential 7,200 sq. ft.	Single Family Res-Combo
05 127370 RK	R-7,200	Residential 7,200 sq. ft.	SFR-Basic
05 127452 RK	R-7,200	Residential 7,200 sq. ft.	Single Family Res-Combo
05 127758 RK	LDMR	Low Density Multiple Reside	SFR-Basic
05 127759 RK	LDMR	Low Density Multiple Reside	SFR-Basic
05 127757 RK	LDMR	Low Density Multiple Reside	SFR-Basic
05 122358 RK	LDMR	Low Density Multiple Reside	Single Family Res-Combo
05 122355 RK	LDMR	Low Density Multiple Reside	Single Family Res-Combo
05 126599 RK	LDMR	Low Density Multiple Reside	SFR-Basic
05 126595 RK	LDMR	Low Density Multiple Reside	SFR-Basic
05 126598 RK	LDMR	Low Density Multiple Reside	SFR-Basic
05 127400 RK	LDMR	Low Density Multiple Reside	SFR-Basic
05 128299 RK	LDMR	Low Density Multiple Reside	SFR-Basic
05 127374 RK	R-7,200	Residential 7,200 sq. ft.	SFR-Basic
05 127479 RK	R-7,200	Residential 7,200 sq. ft.	Single Family Res-Combo
05 125175 RK	R-5	Rural-5 Acre	Single Family Res-Combo
05 125676 RK	R-5	Rural-5 Acre	Single Family Res-Combo
05 125255 RK	R-5	Rural-5 Acre	Single Family Res-Combo
05 125241 RK	CITY	City	SFR-Basic
05 127560 RK	R-5	Rural-5 Acre	Single Family Res-Combo
05 125167 RK	R-5	Rural-5 Acre	SFR-Basic
05 128174 RK	CITY	City	SFR-Basic
05 127802 RK	CITY	City	SFR-Basic
05 127103 RK	CITY	City	SFR-Basic
05 127098 RK	CITY	City	SFR-Basic
05 125999 RK	CITY	City	Single Family Res-Combo
05 127097 RK	CITY	City	SFR-Basic
05 127101 RK	CITY	City	SFR-Basic
05 127347 RK	CITY	City	SFR-Basic
05 127096 RK	CITY	City	SFR-Basic
05 127100 RK	CITY	City	SFR-Basic
05 127349 RK	CITY	City	SFR-Basic
05 127348 RK	CITY	City	SFR-Basic
05 127091 RK	CITY	City	SFR-Basic
05 127979 RK	R-7,200	Residential 7,200 sq. ft.	SFR-Basic
05 127978 RK	R-7,200	Residential 7,200 sq. ft.	SFR-Basic
05 127977 RK	R-7,200	Residential 7,200 sq. ft.	SFR-Basic
05 127976 RK	R-7,200	Residential 7,200 sq. ft.	SFR-Basic
05 127975 RK	R-7,200	Residential 7,200 sq. ft.	SFR-Basic
05 127974 RK	R-7,200	Residential 7,200 sq. ft.	SFR-Basic

Accessory Dwelling Units

Index # - File Name: 1.0022 - Single Family Dwellings Data\_Snohomish County.pdf

05 127973 RK	R-7,200	Residential 7,200 sq. ft.	SFR-Basic
05 128132 RK	R-7,200	Residential 7,200 sq. ft.	SFR-Basic
05 128133 RK	R-7,200	Residential 7,200 sq. ft.	SFR-Basic
05 128134 RK	R-7,200	Residential 7,200 sq. ft.	SFR-Basic
05 128135 RK	R-7,200	Residential 7,200 sq. ft.	SFR-Basic
05 128137 RK	R-7,200	Residential 7,200 sq. ft.	SFR-Basic
05 128138 RK	R-7,200	Residential 7,200 sq. ft.	SFR-Basic
05 128139 RK	R-7,200	Residential 7,200 sq. ft.	SFR-Basic
05 128141 RK	R-7,200	Residential 7,200 sq. ft.	SFR-Basic
05 127972 RK	R-7,200	Residential 7,200 sq. ft.	Single Family Res-Combo
05 127608 RK	R-5	Rural-5 Acre	Single Family Res-Combo
05 128301 RK	LDMR	Low Density Multiple Reside	SFR-Basic
05 128304 RK	LDMR	Low Density Multiple Reside	SFR-Basic
05 128305 RK	LDMR	Low Density Multiple Reside	SFR-Basic
05 127398 RK	LDMR	Low Density Multiple Reside	SFR-Basic
05 127399 RK	LDMR	Low Density Multiple Reside	SFR-Basic
05 125149 RK	LDMR	Low Density Multiple Reside	Single Family Res-Combo
05 125150 RK	LDMR	Low Density Multiple Reside	Duplex-Combo
05 125151 RK	LDMR	Low Density Multiple Reside	Duplex-Combo
05 125152 RK	LDMR	Low Density Multiple Reside	Duplex-Combo
05 128528 RK	R-7,200	Residential 7,200 sq. ft.	SFR-Basic
05 128529 RK	R-7,200	Residential 7,200 sq. ft.	SFR-Basic
05 129086 RK	R-7,200	Residential 7,200 sq. ft.	SFR-Basic
05 126983 RK	R-5	Rural-5 Acre	Single Family Res-Combo
05 125991 RK	R-5	Rural-5 Acre	Single Family Res-Combo
05 128582 RK	R-7,200	Residential 7,200 sq. ft.	SFR-Basic
05 128583 RK	R-7,200	Residential 7,200 sq. ft.	SFR-Basic
05 128584 RK	R-7,200	Residential 7,200 sq. ft.	SFR-Basic
05 128585 RK	R-7,200	Residential 7,200 sq. ft.	SFR-Basic
05 128586 RK	R-7,200	Residential 7,200 sq. ft.	SFR-Basic
05 129096 RK	R-7,200	Residential 7,200 sq. ft.	SFR-Basic
05 129097 RK	R-7,200	Residential 7,200 sq. ft.	SFR-Basic
05 129098 RK	R-7,200	Residential 7,200 sq. ft.	SFR-Basic
05 129099 RK	R-7,200	Residential 7,200 sq. ft.	SFR-Basic
05 128243 RK	R-7,200	Residential 7,200 sq. ft.	SFR-Basic
05 128244 RK	R-7,200	Residential 7,200 sq. ft.	SFR-Basic
05 128245 RK	R-7,200	Residential 7,200 sq. ft.	SFR-Basic
05 128246 RK	R-7,200	Residential 7,200 sq. ft.	SFR-Basic
05 128247 RK	R-7,200	Residential 7,200 sq. ft.	SFR-Basic
05 127807 RK	R-7,200	Residential 7,200 sq. ft.	SFR-Basic
05 127808 RK	R-7,200	Residential 7,200 sq. ft.	SFR-Basic
05 127809 RK	R-7,200	Residential 7,200 sq. ft.	SFR-Basic
05 127810 RK	R-7,200	Residential 7,200 sq. ft.	SFR-Basic
05 127464 RK	R-7,200	Residential 7,200 sq. ft.	SFR-Basic
05 127466 RK	R-7,200	Residential 7,200 sq. ft.	SFR-Basic
05 127469 RK	R-7,200	Residential 7,200 sq. ft.	SFR-Basic
05 127470 RK	R-7,200	Residential 7,200 sq. ft.	SFR-Basic

Accessory Dwelling Units

Index # - File Name: 1.0022 - Single Family Dwellings Data\_Snohomish County.pdf

05 127045 RK	R-7,200	Residential 7,200 sq. ft.	SFR-Basic
05 127046 RK	R-7,200	Residential 7,200 sq. ft.	SFR-Basic
05 127047 RK	R-7,200	Residential 7,200 sq. ft.	SFR-Basic
05 127048 RK	R-7,200	Residential 7,200 sq. ft.	SFR-Basic
05 127049 RK	R-7,200	Residential 7,200 sq. ft.	SFR-Basic
05 127050 RK	R-7,200	Residential 7,200 sq. ft.	SFR-Basic
05 127051 RK	R-7,200	Residential 7,200 sq. ft.	SFR-Basic
05 127052 RK	R-7,200	Residential 7,200 sq. ft.	SFR-Basic
05 127465 RK	R-7,200	Residential 7,200 sq. ft.	SFR-Basic
05 127471 RK	R-7,200	Residential 7,200 sq. ft.	SFR-Basic
05 127467 RK	R-7,200	Residential 7,200 sq. ft.	SFR-Basic
05 127811 RK	R-7,200	Residential 7,200 sq. ft.	SFR-Basic
05 127812 RK	R-7,200	Residential 7,200 sq. ft.	SFR-Basic
05 125780 RK	R-5	Rural-5 Acre	SFR-Basic
05 125783 RK	R-5	Rural-5 Acre	SFR-Basic
05 125789 RK	R-5	Rural-5 Acre	SFR-Basic
05 125827 RK	R-12,500	Residential 12,500 sq. ft.	SFR-Basic
05 129100 RK	R-7,200	Residential 7,200 sq. ft.	SFR-Basic
05 129101 RK	R-7,200	Residential 7,200 sq. ft.	SFR-Basic
05 125945 RK	RD	Rural Diversification	Single Family Res-Combo
05 125943 RK	RD	Rural Diversification	Single Family Res-Combo
05 126166 RK	A-10	Agriculture-10 Acre	Single Family Res-Combo
05 126773 RK	R-7,200	Residential 7,200 sq. ft.	SFR-Basic
05 128016 RK	R-7,200(PRD)	Residential 7,200 sq. ft.	SFR-Basic
05 128019 RK	R-7,200(PRD)	Residential 7,200 sq. ft.	SFR-Basic
05 128018 RK	R-7,200(PRD)	Residential 7,200 sq. ft.	SFR-Basic
05 128012 RK	R-7,200(PRD)	Residential 7,200 sq. ft.	SFR-Basic
05 128014 RK	R-7,200(PRD)	Residential 7,200 sq. ft.	SFR-Basic
05 128889 RK	CITY	City	SFR-Basic
05 128890 RK	CITY	City	SFR-Basic
05 128891 RK	CITY	City	SFR-Basic
05 128893 RK	CITY	City	SFR-Basic
05 128999 RK	CITY	City	SFR-Basic
05 128894 RK	CITY	City	SFR-Basic
05 128897 RK	CITY	City	SFR-Basic
05 128900 RK	CITY	City	SFR-Basic
05 128896 RK	CITY	City	SFR-Basic
05 128902 RK	CITY	City	SFR-Basic
05 128892 RK	CITY	City	SFR-Basic
05 129004 RK	CITY	City	SFR-Basic
05 129000 RK	CITY	City	SFR-Basic
05 128895 RK	CITY	City	SFR-Basic
05 129003 RK	CITY	City	SFR-Basic
05 128898 RK	CITY	City	SFR-Basic
05 129001 RK	CITY	City	SFR-Basic
05 129002 RK	CITY	City	SFR-Basic
05 128901 RK	CITY	City	SFR-Basic

Accessory Dwelling Units

Index # - File Name: 1.0022 - Single Family Dwellings Data\_Snohomish County.pdf

05 128899 RK	CITY	City	SFR-Basic
05 124838 RK	R-5	Rural-5 Acre	Single Family Res-Combo
05 125298 RK	R-5	Rural-5 Acre	Single Family Res-Combo
05 128113 RK	MR	Multiple Residential	Duplex-Basic
05 128114 RK	MR	Multiple Residential	Duplex-Basic
04 120627 RK	RRT-10	Rural Resource Transition-10	Single Family Res-Combo
05 125981 RK	R-5	Rural-5 Acre	Single Family Res-Combo
05 118374 RK	RRT-10	Rural Resource Transition-10	Single Family Res-Combo
04 121027 RK	RRT-10	Rural Resource Transition-10	Single Family Res-Combo
05 118345 RK	RRT-10	Rural Resource Transition-10	Single Family Res-Combo
05 101216 RK	R-5	Rural-5 Acre	Single Family Res-Combo
05 123657 RK	R-5	Rural-5 Acre	Single Family Res-Combo
05 123655 RK	R-5	Rural-5 Acre	Single Family Res-Combo
05 126759 RK	R-5	Rural-5 Acre	Single Family Res-Combo
05 121539 RK	A-10	Agriculture-10 Acre	Single Family Res-Combo
05 116529 RK	R-5	Rural-5 Acre	Single Family Res-Combo
05 124262 RK	R-5	Rural-5 Acre	Single Family Res-Combo
05 116099 RK	CITY	City	Single Family Res-Combo
05 119544 RK	CITY	City	Single Family Res-Combo
05 119548 RK	CITY	City	SFR-Basic
05 125283 RK	CITY	City	SFR-Basic
05 121088 RK	CITY	City	SFR-Basic
04 121314 RK	SA-1	Suburban Agriculture-1 Acre	Single Family Res-Combo
04 115423 RK	R-5	Rural-5 Acre	Single Family Res-Combo
05 125155 RK	R-5	Rural-5 Acre	Single Family Res-Combo
05 101201 RK	R-5	Rural-5 Acre	Single Family Res-Combo
05 123770 RK	R-5	Rural-5 Acre	Single Family Res-Combo
04 120645 RK	R-5	Rural-5 Acre	Single Family Res-Combo
05 118089 RK	R-9,600	Residential 9,600 sq. ft.	SFR-Basic
05 128130 RK	R-9,600	Residential 9,600 sq. ft.	SFR-Basic
05 117322 RK	R-9,600	Residential 9,600 sq. ft.	SFR-Basic
05 120877 RK	R-9,600	Residential 9,600 sq. ft.	SFR-Basic
05 125722 RK	R-5	Rural-5 Acre	Single Family Res-Combo
05 123196 RK	R-5	Rural-5 Acre	Single Family Res-Combo
05 118846 RK	R-5	Rural-5 Acre	Single Family Res-Combo
05 124139 RK	R-9,600	Residential 9,600 sq. ft.	Single Family Res-Combo
05 116382 RK	R-9,600	Residential 9,600 sq. ft.	Single Family Res-Combo
05 118094 RK	R-9,600	Residential 9,600 sq. ft.	SFR-Basic
05 120493 RK	R-9,600	Residential 9,600 sq. ft.	SFR-Basic
05 100581 RK	R-9,600	Residential 9,600 sq. ft.	SFR-Basic
05 101985 RK	R-9,600	Residential 9,600 sq. ft.	SFR-Basic
05 118090 RK	R-9,600	Residential 9,600 sq. ft.	SFR-Basic
05 118093 RK	R-9,600	Residential 9,600 sq. ft.	SFR-Basic
05 120488 RK	R-9,600	Residential 9,600 sq. ft.	SFR-Basic
05 117210 RK	R-9,600	Residential 9,600 sq. ft.	SFR-Basic
05 117320 RK	R-9,600	Residential 9,600 sq. ft.	SFR-Basic
05 100589 RK	R-9,600	Residential 9,600 sq. ft.	Single Family Res-Combo



Accessory Dwelling Units

Index # - File Name: 1.0022 - Single Family Dwellings Data\_Snohomish County.pdf

05 120130 RK	R-9,600	Residential 9,600 sq. ft.	SFR-Basic
05 101017 RK	R-9,600	Residential 9,600 sq. ft.	SFR-Basic
05 118086 RK	R-9,600	Residential 9,600 sq. ft.	Single Family Res-Combo
05 100585 RK	R-9,600	Residential 9,600 sq. ft.	SFR-Basic
05 117213 RK	R-9,600	Residential 9,600 sq. ft.	SFR-Basic
05 117214 RK	R-9,600	Residential 9,600 sq. ft.	SFR-Basic
05 100608 RK	R-9,600	Residential 9,600 sq. ft.	Single Family Res-Combo
05 119646 RK	R-9,600	Residential 9,600 sq. ft.	SFR-Basic
05 120480 RK	R-9,600	Residential 9,600 sq. ft.	SFR-Basic
05 100986 RK	R-9,600	Residential 9,600 sq. ft.	Single Family Res-Combo
05 100983 RK	R-9,600	Residential 9,600 sq. ft.	SFR-Basic
05 119655 RK	R-9,600	Residential 9,600 sq. ft.	SFR-Basic
05 100049 RK	R-5	Rural-5 Acre	Single Family Res-Combo
04 121522 RK	R-5	Rural-5 Acre	Single Family Res-Combo
05 116376 RK	R-9,600	Residential 9,600 sq. ft.	SFR-Basic
05 100582 RK	R-9,600	Residential 9,600 sq. ft.	SFR-Basic
05 102034 RK	CITY	City	Single Family Res-Combo
05 117458 RK	CITY	City	Single Family Res-Combo
05 120426 RK	R-5	Rural-5 Acre	Single Family Res-Combo
05 119061 RK	CITY	City	Single Family Res-Combo
04 110549 RK	R-5	Rural-5 Acre	Single Family Res-Combo
05 123039 RK	R-5	Rural-5 Acre	Single Family Res-Combo
05 116946 RK	F	Forestry	Single Family Res-Combo
05 126324 RK	PRD-9,600	Residential 9,600 sq. ft.	SFR-Basic
05 126322 RK	PRD-9,600	Residential 9,600 sq. ft.	SFR-Basic
04 121068 RK	R-5	Rural-5 Acre	Single Family Res-Combo
05 121616 RK	R-5	Rural-5 Acre	Single Family Res-Combo
04 113459 001 00 RK	R-5	Rural-5 Acre	Single Family Res-Combo
03 107940 000 01 RK	R-5	Rural-5 Acre	Single Family Res-Combo
04 116105 RK	R-5	Rural-5 Acre	Single Family Res-Combo
05 119770 RK	R-5	Rural-5 Acre	Single Family Res-Combo
05 101856 RK	R-5	Rural-5 Acre	Single Family Res-Combo
05 124263 RK	R-5	Rural-5 Acre	Single Family Res-Combo
05 100528 RK	R-5	Rural-5 Acre	Single Family Res-Combo
05 125760 RK	R-5	Rural-5 Acre	Single Family Res-Combo
05 125762 RK	R-5	Rural-5 Acre	Single Family Res-Combo
05 123804 RK	R-5	Rural-5 Acre	Single Family Res-Combo
05 116067 MH	CITY	City	Triple Wide
05 117050 RK	R-7,200	Residential 7,200 sq. ft.	SFR-Basic
05 117047 RK	R-7,200	Residential 7,200 sq. ft.	SFR-Basic
03 103957 000 01 RK	R-5	Rural-5 Acre	Single Family Res-Combo
05 119651 RK	R-7,200	Residential 7,200 sq. ft.	SFR-Basic
05 100609 RK	R-7,200	Residential 7,200 sq. ft.	SFR-Basic
05 123489 RK	R-5	Rural-5 Acre	Single Family Res-Combo
05 119543 RK	CITY	City	Single Family Res-Combo
04 121752 RK	R-5	Rural-5 Acre	Single Family Res-Combo
04 116672 RK	R-9,600	Residential 9,600 sq. ft.	Single Family Res-Combo

Accessory Dwelling Units

Index # - File Name: 1.0022 - Single Family Dwellings Data\_Snohomish County.pdf

04 112037 RK	PRD-7,200	Residential 7,200 sq. ft.	SFR-Basic
04 112040 RK	PRD-7,200	Residential 7,200 sq. ft.	SFR-Basic
04 112038 RK	PRD-7,200	Residential 7,200 sq. ft.	SFR-Basic
05 119934 RK	PRD-7,200	Residential 7,200 sq. ft.	SFR-Basic
04 112041 RK	PRD-7,200	Residential 7,200 sq. ft.	SFR-Basic
04 112042 RK	PRD-7,200	Residential 7,200 sq. ft.	SFR-Basic
04 112039 RK	PRD-7,200	Residential 7,200 sq. ft.	SFR-Basic
04 120636 RK	R-7,200	Residential 7,200 sq. ft.	Duplex-Combo
04 120578 RK	R-5	Rural-5 Acre	Single Family Res-Combo
03 102995 000 01 RK	PRD-7,200	Residential 7,200 sq. ft.	Single Family Res-Combo
05 119935 RK	PRD-7,200	Residential 7,200 sq. ft.	SFR-Basic
05 119936 RK	PRD-7,200	Residential 7,200 sq. ft.	SFR-Basic
03 104666 000 01 RK	A-10	Agriculture-10 Acre	Single Family Res-Combo
05 118805 RK	R-5	Rural-5 Acre	Single Family Res-Combo
04 119657 RK	R-9,600	Residential 9,600 sq. ft.	Single Family Res-Combo
05 101119 RK	R-9,600	Residential 9,600 sq. ft.	Single Family Res-Combo
05 116134 RK	PRD-9,600 : R-	Residential 9,600 sq. ft.	Single Family Res-Combo
05 120954 RK	R-9,600	Residential 9,600 sq. ft.	Single Family Res-Combo
05 119709 RK	R-9,600	Residential 9,600 sq. ft.	Single Family Res-Combo
05 117431 RK	R-9,600	Residential 9,600 sq. ft.	Single Family Res-Combo
05 117045 RK	R-9,600	Residential 9,600 sq. ft.	Single Family Res-Combo
05 117818 RK	R-7,200	Residential 7,200 sq. ft.	Duplex-Combo
05 101184 RK	R-5	Rural-5 Acre	Single Family Res-Combo
05 117230 RK	R-5	Rural-5 Acre	Single Family Res-Combo
05 121485 MH	RRT-10	Rural Resource Transition-10	Triple Wide
05 120282 RK	R-9,600	Residential 9,600 sq. ft.	SFR-Basic
04 119529 001 00 RK	R-5	Rural-5 Acre	Single Family Res-Combo
04 119529 RK	R-5	Rural-5 Acre	Single Family Res-Combo
04 119532 RK	R-5	Rural-5 Acre	Single Family Res-Combo
05 116269 RK	R-5	Rural-5 Acre	Single Family Res-Combo
04 118575 RK	R-5	Rural-5 Acre	Single Family Res-Combo
05 116088 RK	R-5	Rural-5 Acre	Single Family Res-Combo
05 101190 RK	R-5	Rural-5 Acre	Single Family Res-Combo
05 102111 RK	R-5	Rural-5 Acre	Single Family Res-Combo
05 120160 RK	R-5	Rural-5 Acre	Single Family Res-Combo
05 120161 RK	R-5	Rural-5 Acre	Single Family Res-Combo
05 126362 RK	R-5	Rural-5 Acre	Single Family Res-Combo
05 122001 RK	R-5	Rural-5 Acre	Single Family Res-Combo
05 101307 RK	R-5	Rural-5 Acre	Single Family Res-Combo
05 100805 RK	R-5	Rural-5 Acre	SFR-Basic
05 123107 MH	MHP	Mobile Home Park	MH Park-Double Wide
05 125230 RK	R-7,200	Residential 7,200 sq. ft.	SFR-Basic
05 124791 RK	R-7,200	Residential 7,200 sq. ft.	SFR-Basic
05 125223 RK	R-7,200	Residential 7,200 sq. ft.	SFR-Basic
05 125842 RK	R-7,200	Residential 7,200 sq. ft.	SFR-Basic
05 124794 RK	R-7,200	Residential 7,200 sq. ft.	SFR-Basic
05 125843 RK	R-7,200	Residential 7,200 sq. ft.	SFR-Basic

Accessory Dwelling Units

Index # - File Name: 1.0022 - Single Family Dwellings Data\_Snohomish County.pdf

05 125225 RK	R-7,200	Residential 7,200 sq. ft.	SFR-Basic
05 126116 RK	R-7,200	Residential 7,200 sq. ft.	SFR-Basic
05 128465 RK	R-7,200	Residential 7,200 sq. ft.	SFR-Basic
05 128468 RK	R-7,200	Residential 7,200 sq. ft.	SFR-Basic
05 126117 RK	R-7,200	Residential 7,200 sq. ft.	SFR-Basic
05 125536 RK	R-7,200	Residential 7,200 sq. ft.	SFR-Basic
05 126335 RK	R-7,200	Residential 7,200 sq. ft.	SFR-Basic
05 125227 RK	R-7,200	Residential 7,200 sq. ft.	SFR-Basic
05 125533 RK	R-7,200	Residential 7,200 sq. ft.	SFR-Basic
05 125231 RK	R-7,200	Residential 7,200 sq. ft.	SFR-Basic
05 101192 RK	R-7,200	Residential 7,200 sq. ft.	SFR-Basic
05 101431 RK	R-7,200	Residential 7,200 sq. ft.	SFR-Basic
05 127676 RK	R-7,200	Residential 7,200 sq. ft.	SFR-Basic
05 100398 RK	R-7,200	Residential 7,200 sq. ft.	SFR-Basic
04 121387 RK	R-7,200	Residential 7,200 sq. ft.	SFR-Basic
05 117087 RK	R-7,200	Residential 7,200 sq. ft.	SFR-Basic
05 127677 RK	R-7,200	Residential 7,200 sq. ft.	SFR-Basic
05 101428 RK	R-7,200	Residential 7,200 sq. ft.	SFR-Basic
05 116054 RK	R-7,200	Residential 7,200 sq. ft.	SFR-Basic
05 100048 RK	R-7,200	Residential 7,200 sq. ft.	SFR-Basic
05 101191 RK	R-7,200	Residential 7,200 sq. ft.	SFR-Basic
05 120491 RK	R-7,200	Residential 7,200 sq. ft.	SFR-Basic
05 120495 RK	R-7,200	Residential 7,200 sq. ft.	SFR-Basic
05 121247 RK	R-7,200	Residential 7,200 sq. ft.	SFR-Basic
05 121715 RK	R-7,200	Residential 7,200 sq. ft.	SFR-Basic
05 121726 RK	R-7,200	Residential 7,200 sq. ft.	SFR-Basic
05 122913 RK	R-7,200	Residential 7,200 sq. ft.	SFR-Basic
05 121459 RK	R-7,200	Residential 7,200 sq. ft.	SFR-Basic
05 122916 RK	R-7,200	Residential 7,200 sq. ft.	SFR-Basic
05 121721 RK	R-7,200	Residential 7,200 sq. ft.	SFR-Basic
05 121683 RK	R-7,200	Residential 7,200 sq. ft.	SFR-Basic
05 122917 RK	R-7,200	Residential 7,200 sq. ft.	SFR-Basic
05 121727 RK	R-7,200	Residential 7,200 sq. ft.	SFR-Basic
05 122911 RK	R-7,200	Residential 7,200 sq. ft.	SFR-Basic
05 123449 RK	R-7,200	Residential 7,200 sq. ft.	SFR-Basic
05 123189 RK	R-7,200	Residential 7,200 sq. ft.	SFR-Basic
05 123191 RK	R-7,200	Residential 7,200 sq. ft.	SFR-Basic
05 124094 RK	R-7,200	Residential 7,200 sq. ft.	SFR-Basic
05 123447 RK	R-7,200	Residential 7,200 sq. ft.	SFR-Basic
05 123445 RK	R-7,200	Residential 7,200 sq. ft.	SFR-Basic
05 123187 RK	R-7,200	Residential 7,200 sq. ft.	SFR-Basic
05 101180 RK	R-5	Rural-5 Acre	Single Family Res-Combo
05 121638 RK	R-5	Rural-5 Acre	Single Family Res-Combo
05 128464 RK	R-7,200	Residential 7,200 sq. ft.	SFR-Basic
05 119330 RK	R-5	Rural-5 Acre	Single Family Res-Combo
04 121527 RK	CITY	City	Single Family Res-Combo
05 126334 RK	R-7,200	Residential 7,200 sq. ft.	SFR-Basic

Accessory Dwelling Units

Index # - File Name: 1.0022 - Single Family Dwellings Data\_Snohomish County.pdf

05 123693 RK	R-7,200	Residential 7,200 sq. ft.	SFR-Basic
05 123192 RK	R-7,200	Residential 7,200 sq. ft.	SFR-Basic
05 123441 RK	R-7,200	Residential 7,200 sq. ft.	SFR-Basic
05 117129 RK	R-5	Rural-5 Acre	Single Family Res-Combo
05 121368 RK	R-5	Rural-5 Acre	Single Family Res-Combo
05 124950 RK	R-5	Rural-5 Acre	SFR-Basic
05 118371 RK	R-5	Rural-5 Acre	Single Family Res-Combo
05 117735 RK	R-5	Rural-5 Acre	SFR-Basic
05 100744 RK	R-5	Rural-5 Acre	SFR-Basic
05 116864 RK	R-5	Rural-5 Acre	Single Family Res-Combo
05 117673 RK	R-5	Rural-5 Acre	Single Family Res-Combo
05 101539 RK	PRD-7,200	Residential 7,200 sq. ft.	SFR-Basic
05 101540 RK	PRD-7,200	Residential 7,200 sq. ft.	SFR-Basic
04 113938 RK	PRD-7,200	Residential 7,200 sq. ft.	SFR-Basic
05 119937 RK	PRD-7,200	Residential 7,200 sq. ft.	SFR-Basic
05 119955 RK	PRD-7,200	Residential 7,200 sq. ft.	SFR-Basic
05 119938 RK	PRD-7,200	Residential 7,200 sq. ft.	SFR-Basic
05 119940 RK	PRD-7,200	Residential 7,200 sq. ft.	SFR-Basic
05 119941 RK	PRD-7,200	Residential 7,200 sq. ft.	SFR-Basic
05 119942 RK	PRD-7,200	Residential 7,200 sq. ft.	SFR-Basic
05 119943 RK	PRD-7,200	Residential 7,200 sq. ft.	SFR-Basic
05 119944 RK	PRD-7,200	Residential 7,200 sq. ft.	SFR-Basic
05 101536 RK	PRD-7,200	Residential 7,200 sq. ft.	SFR-Basic
04 113932 RK	PRD-7,200	Residential 7,200 sq. ft.	SFR-Basic
04 113945 RK	PRD-7,200	Residential 7,200 sq. ft.	SFR-Basic
04 113944 RK	PRD-7,200	Residential 7,200 sq. ft.	SFR-Basic
04 113943 RK	PRD-7,200	Residential 7,200 sq. ft.	SFR-Basic
04 113942 RK	PRD-7,200	Residential 7,200 sq. ft.	SFR-Basic
04 113913 RK	PRD-7,200	Residential 7,200 sq. ft.	SFR-Basic
05 119964 RK	PRD-7,200	Residential 7,200 sq. ft.	SFR-Basic
04 113940 RK	PRD-7,200	Residential 7,200 sq. ft.	SFR-Basic
04 113924 RK	PRD-7,200	Residential 7,200 sq. ft.	SFR-Basic
04 113923 RK	PRD-7,200	Residential 7,200 sq. ft.	SFR-Basic
04 113922 RK	PRD-7,200	Residential 7,200 sq. ft.	SFR-Basic
04 113920 RK	PRD-7,200	Residential 7,200 sq. ft.	SFR-Basic
05 100512 RK	PRD-7,200	Residential 7,200 sq. ft.	SFR-Basic
04 121392 RK	R-5	Rural-5 Acre	SFR-Basic
04 121390 RK	R-5	Rural-5 Acre	SFR-Basic
05 101001 RK	R-5	Rural-5 Acre	SFR-Basic
05 119772 RK	R-5	Rural-5 Acre	SFR-Basic
04 118917 RK	R-5	Rural-5 Acre	SFR-Basic
05 117739 RK	R-5	Rural-5 Acre	SFR-Basic
05 117740 RK	R-5	Rural-5 Acre	SFR-Basic
05 100010 RK	R-5	Rural-5 Acre	SFR-Basic
04 121397 RK	R-5	Rural-5 Acre	SFR-Basic
05 101000 RK	R-5	Rural-5 Acre	SFR-Basic
04 121386 RK	R-5	Rural-5 Acre	SFR-Basic

Accessory Dwelling Units

Index # - File Name: 1.0022 - Single Family Dwellings Data\_Snohomish County.pdf

05 117744 RK	R-5	Rural-5 Acre	SFR-Basic
05 117746 RK	R-5	Rural-5 Acre	SFR-Basic
05 117747 RK	R-5	Rural-5 Acre	SFR-Basic
05 100014 RK	R-5	Rural-5 Acre	SFR-Basic
05 119766 RK	R-5	Rural-5 Acre	SFR-Basic
05 119547 RK	R-5	Rural-5 Acre	SFR-Basic
05 100015 RK	R-5	Rural-5 Acre	SFR-Basic
04 121381 RK	R-5	Rural-5 Acre	SFR-Basic
05 116509 RK	R-5	Rural-5 Acre	SFR-Basic
05 100017 RK	R-5	Rural-5 Acre	SFR-Basic
05 100018 RK	R-5	Rural-5 Acre	SFR-Basic
05 100020 RK	R-5	Rural-5 Acre	SFR-Basic
05 117732 RK	R-5	Rural-5 Acre	SFR-Basic
05 117734 RK	R-5	Rural-5 Acre	SFR-Basic
05 116360 RK	PRD-9,600	Residential 9,600 sq. ft.	SFR-Basic
05 116359 RK	PRD-9,600	Residential 9,600 sq. ft.	SFR-Basic
05 100093 RK	PRD-9,600	Residential 9,600 sq. ft.	SFR-Basic
05 101885 RK	R-7,200(PRD)	Residential 7,200 sq. ft.	SFR-Basic
04 115313 RK	R-5	Rural-5 Acre	Single Family Res-Combo
05 120285 RK	PRD-9,600	Residential 9,600 sq. ft.	SFR-Basic
05 100094 RK	PRD-9,600	Residential 9,600 sq. ft.	SFR-Basic
05 116358 RK	PRD-9,600	Residential 9,600 sq. ft.	SFR-Basic
05 117956 RK	R-7,200(PRD)	Residential 7,200 sq. ft.	SFR-Basic
05 117784 RK	R-7,200(PRD)	Residential 7,200 sq. ft.	SFR-Basic
05 121169 RK	R-7,200(PRD)	Residential 7,200 sq. ft.	SFR-Basic
05 124832 RK	R-7,200(PRD)	Residential 7,200 sq. ft.	SFR-Basic
05 117785 RK	R-7,200(PRD)	Residential 7,200 sq. ft.	SFR-Basic
05 121886 RK	R-7,200(PRD)	Residential 7,200 sq. ft.	SFR-Basic
05 116129 RK	R-7,200(PRD)	Residential 7,200 sq. ft.	SFR-Basic
05 121889 RK	R-7,200(PRD)	Residential 7,200 sq. ft.	SFR-Basic
05 123498 RK	R-7,200(PRD)	Residential 7,200 sq. ft.	SFR-Basic
05 117012 RK	R-7,200(PRD)	Residential 7,200 sq. ft.	SFR-Basic
05 124834 RK	R-7,200(PRD)	Residential 7,200 sq. ft.	SFR-Basic
05 122196 RK	R-7,200(PRD)	Residential 7,200 sq. ft.	SFR-Basic
05 120900 RK	R-7,200(PRD)	Residential 7,200 sq. ft.	SFR-Basic
05 116132 RK	R-7,200(PRD)	Residential 7,200 sq. ft.	SFR-Basic
05 124845 RK	R-7,200(PRD)	Residential 7,200 sq. ft.	SFR-Basic
05 125636 RK	R-7,200(PRD)	Residential 7,200 sq. ft.	SFR-Basic
05 125866 RK	R-7,200(PRD)	Residential 7,200 sq. ft.	SFR-Basic
05 124831 RK	R-7,200(PRD)	Residential 7,200 sq. ft.	SFR-Basic
05 127761 RK	R-7,200(PRD)	Residential 7,200 sq. ft.	SFR-Basic
05 127762 RK	R-7,200(PRD)	Residential 7,200 sq. ft.	SFR-Basic
05 126879 RK	R-7,200(PRD)	Residential 7,200 sq. ft.	SFR-Basic
05 126881 RK	R-7,200(PRD)	Residential 7,200 sq. ft.	SFR-Basic
05 126882 RK	R-7,200(PRD)	Residential 7,200 sq. ft.	SFR-Basic
05 121578 RK	R-7,200(PRD)	Residential 7,200 sq. ft.	SFR-Basic
05 119751 RK	R-7,200(PRD)	Residential 7,200 sq. ft.	SFR-Basic

Accessory Dwelling Units

Index # - File Name: 1.0022 - Single Family Dwellings Data\_Snohomish County.pdf

05 119517 RK	R-7,200(PRD)	Residential 7,200 sq. ft.	SFR-Basic
05 102032 RK	RRT-10	Rural Resource Transition-10	Single Family Res-Combo
05 116354 RK	R-7,200	Residential 7,200 sq. ft.	SFR-Basic
05 100393 RK	R-7,200	Residential 7,200 sq. ft.	SFR-Basic
05 121021 RK	R-9,600	Residential 9,600 sq. ft.	SFR-Basic
05 121022 RK	R-9,600	Residential 9,600 sq. ft.	SFR-Basic
05 121023 RK	R-9,600	Residential 9,600 sq. ft.	SFR-Basic
05 121024 RK	R-9,600	Residential 9,600 sq. ft.	SFR-Basic
05 116651 RK	R-9,600	Residential 9,600 sq. ft.	SFR-Basic
05 101675 RK	R-9,600	Residential 9,600 sq. ft.	SFR-Basic
05 116645 RK	R-9,600	Residential 9,600 sq. ft.	SFR-Basic
05 118577 RK	R-9,600	Residential 9,600 sq. ft.	SFR-Basic
05 119134 RK	R-9,600	Residential 9,600 sq. ft.	SFR-Basic
05 118578 RK	R-9,600	Residential 9,600 sq. ft.	SFR-Basic
05 118579 RK	R-9,600	Residential 9,600 sq. ft.	SFR-Basic
05 118580 RK	R-9,600	Residential 9,600 sq. ft.	SFR-Basic
05 119135 RK	R-9,600	Residential 9,600 sq. ft.	SFR-Basic
05 119137 RK	R-9,600	Residential 9,600 sq. ft.	SFR-Basic
05 119138 RK	R-9,600	Residential 9,600 sq. ft.	SFR-Basic
05 119139 RK	R-9,600	Residential 9,600 sq. ft.	SFR-Basic
05 119141 RK	R-9,600	Residential 9,600 sq. ft.	SFR-Basic
05 118581 RK	R-9,600	Residential 9,600 sq. ft.	SFR-Basic
05 118582 RK	R-9,600	Residential 9,600 sq. ft.	SFR-Basic
05 101127 RK	R-9,600	Residential 9,600 sq. ft.	SFR-Basic
05 101126 RK	R-9,600	Residential 9,600 sq. ft.	SFR-Basic
05 101128 RK	R-9,600	Residential 9,600 sq. ft.	SFR-Basic
05 116647 RK	R-9,600	Residential 9,600 sq. ft.	SFR-Basic
05 116649 RK	R-9,600	Residential 9,600 sq. ft.	SFR-Basic
05 116650 RK	R-9,600	Residential 9,600 sq. ft.	SFR-Basic
05 117628 RK	R-5	Rural-5 Acre	Single Family Res-Combo
05 121011 RK	A-10	Agriculture-10 Acre	Single Family Res-Combo
05 124694 RK	R-5	Rural-5 Acre	Single Family Res-Combo
05 100532 RK	R-7,200	Residential 7,200 sq. ft.	SFR-Basic
05 101836 RK	R-7,200	Residential 7,200 sq. ft.	SFR-Basic
05 116657 RK	R-7,200	Residential 7,200 sq. ft.	SFR-Basic
05 101436 RK	R-7,200	Residential 7,200 sq. ft.	SFR-Basic
05 117085 RK	R-7,200	Residential 7,200 sq. ft.	SFR-Basic
05 116355 RK	R-7,200	Residential 7,200 sq. ft.	SFR-Basic
05 120767 RK	R-7,200	Residential 7,200 sq. ft.	SFR-Basic
05 118614 RK	R-7,200	Residential 7,200 sq. ft.	SFR-Basic
05 100760 RK	R-7,200	Residential 7,200 sq. ft.	SFR-Basic
05 101196 RK	R-7,200	Residential 7,200 sq. ft.	SFR-Basic
04 121556 RK	R-7,200	Residential 7,200 sq. ft.	SFR-Basic
05 120776 RK	R-7,200	Residential 7,200 sq. ft.	SFR-Basic
05 118935 RK	R-7,200	Residential 7,200 sq. ft.	SFR-Basic
05 118299 RK	R-7,200	Residential 7,200 sq. ft.	SFR-Basic
05 122165 RK	R-7,200	Residential 7,200 sq. ft.	SFR-Basic

Accessory Dwelling Units

Index # - File Name: 1.0022 - Single Family Dwellings Data\_Snohomish County.pdf

05 117342 RK	R-7,200	Residential 7,200 sq. ft.	SFR-Basic
05 118608 RK	R-7,200	Residential 7,200 sq. ft.	SFR-Basic
05 100759 RK	R-7,200	Residential 7,200 sq. ft.	SFR-Basic
05 100964 RK	R-7,200	Residential 7,200 sq. ft.	SFR-Basic
05 101188 RK	R-7,200	Residential 7,200 sq. ft.	SFR-Basic
05 116052 RK	R-7,200	Residential 7,200 sq. ft.	SFR-Basic
05 118595 RK	R-7,200	Residential 7,200 sq. ft.	SFR-Basic
05 101197 RK	R-7,200	Residential 7,200 sq. ft.	SFR-Basic
05 118269 RK	R-7,200	Residential 7,200 sq. ft.	SFR-Basic
05 116658 RK	R-7,200	Residential 7,200 sq. ft.	SFR-Basic
05 117089 RK	R-7,200	Residential 7,200 sq. ft.	SFR-Basic
05 118611 RK	R-7,200	Residential 7,200 sq. ft.	SFR-Basic
05 117670 RK	R-7,200	Residential 7,200 sq. ft.	SFR-Basic
05 119429 RK	R-7,200	Residential 7,200 sq. ft.	SFR-Basic
05 118267 RK	R-7,200	Residential 7,200 sq. ft.	SFR-Basic
05 119431 RK	R-7,200	Residential 7,200 sq. ft.	SFR-Basic
05 119716 RK	R-7,200	Residential 7,200 sq. ft.	SFR-Basic
05 117925 RK	R-7,200	Residential 7,200 sq. ft.	SFR-Basic
05 118936 RK	R-7,200	Residential 7,200 sq. ft.	SFR-Basic
05 118302 RK	R-7,200	Residential 7,200 sq. ft.	SFR-Basic
05 117926 RK	R-7,200	Residential 7,200 sq. ft.	SFR-Basic
05 118599 RK	R-7,200	Residential 7,200 sq. ft.	SFR-Basic
05 118937 RK	R-7,200	Residential 7,200 sq. ft.	SFR-Basic
05 119715 RK	R-7,200	Residential 7,200 sq. ft.	SFR-Basic
05 118612 RK	R-7,200	Residential 7,200 sq. ft.	SFR-Basic
05 118293 RK	R-7,200	Residential 7,200 sq. ft.	SFR-Basic
05 117666 RK	R-7,200	Residential 7,200 sq. ft.	SFR-Basic
05 118934 RK	R-7,200	Residential 7,200 sq. ft.	SFR-Basic
05 117091 RK	R-7,200	Residential 7,200 sq. ft.	SFR-Basic
05 119427 RK	R-7,200	Residential 7,200 sq. ft.	SFR-Basic
05 118929 RK	R-7,200	Residential 7,200 sq. ft.	SFR-Basic
05 118613 RK	R-7,200	Residential 7,200 sq. ft.	SFR-Basic
05 118297 RK	R-7,200	Residential 7,200 sq. ft.	SFR-Basic
05 100395 RK	R-7,200	Residential 7,200 sq. ft.	SFR-Basic
05 100757 RK	R-7,200	Residential 7,200 sq. ft.	SFR-Basic
05 116352 RK	R-7,200	Residential 7,200 sq. ft.	SFR-Basic
05 100397 RK	R-7,200	Residential 7,200 sq. ft.	SFR-Basic
04 121563 RK	R-7,200	Residential 7,200 sq. ft.	SFR-Basic
05 101830 RK	R-7,200	Residential 7,200 sq. ft.	SFR-Basic
05 101834 RK	R-7,200	Residential 7,200 sq. ft.	SFR-Basic
05 116350 RK	R-7,200	Residential 7,200 sq. ft.	SFR-Basic
05 118932 RK	R-7,200	Residential 7,200 sq. ft.	SFR-Basic
05 121701 RK	R-7,200	Residential 7,200 sq. ft.	SFR-Basic
05 121457 RK	R-7,200	Residential 7,200 sq. ft.	SFR-Basic
05 120499 RK	R-7,200	Residential 7,200 sq. ft.	SFR-Basic
05 120773 RK	R-7,200	Residential 7,200 sq. ft.	SFR-Basic
05 121456 RK	R-7,200	Residential 7,200 sq. ft.	SFR-Basic

Accessory Dwelling Units

Index # - File Name: 1.0022 - Single Family Dwellings Data\_Snohomish County.pdf

05 120484 RK	R-7,200	Residential 7,200 sq. ft.	SFR-Basic
05 100389 RK	R-7,200	Residential 7,200 sq. ft.	SFR-Basic
05 120399 RK	RRT-10	Rural Resource Transition-1(Single Family Res-Combo	
05 125781 RK	RRT-10	Rural Resource Transition-1(Single Family Res-Combo	
05 101162 RK	RRT-10	Rural Resource Transition-1(Single Family Res-Combo	
04 120869 RK	RRT-10	Rural Resource Transition-1(Single Family Res-Combo	
05 119961 RK	RRT-10	Rural Resource Transition-1(Single Family Res-Combo	
05 116206 RK	RRT-10	Rural Resource Transition-1(Single Family Res-Combo	
05 100645 RK	RRT-10	Rural Resource Transition-1(SFR-Basic	
05 100644 RK	RRT-10	Rural Resource Transition-1(SFR-Basic	
05 116208 RK	RRT-10	Rural Resource Transition-1(Single Family Res-Combo	
05 101821 RK	RRT-10	Rural Resource Transition-1(Single Family Res-Combo	
05 101672 RK	RRT-10	Rural Resource Transition-1(Single Family Res-Combo	
05 100401 RK	RRT-10	Rural Resource Transition-1(Single Family Res-Combo	
05 120295 RK	RRT-10	Rural Resource Transition-1(Single Family Res-Combo	
05 116212 RK	RRT-10	Rural Resource Transition-1(Single Family Res-Combo	
05 119807 RK	R-5	Rural-5 Acre	Single Family Res-Combo
05 117839 RK	R-5	Rural-5 Acre	Single Family Res-Combo
05 100250 RK	R-9,600	Residential 9,600 sq. ft.	SFR-Basic
05 100251 RK	R-9,600	Residential 9,600 sq. ft.	Single Family Res-Combo
05 101270 RK	R-9,600	Residential 9,600 sq. ft.	SFR-Basic
05 101823 RK	R-9,600	Residential 9,600 sq. ft.	Single Family Res-Combo
04 109379 RK	R-5	Rural-5 Acre	SFR-Basic
05 101026 RK	RRT-10	Rural Resource Transition-1(Single Family Res-Combo	
05 123258 RK	RRT-10	Rural Resource Transition-1(Single Family Res-Combo	
05 116315 RK	RRT-10	Rural Resource Transition-1(Single Family Res-Combo	
05 116556 RK	RRT-10	Rural Resource Transition-1(Single Family Res-Combo	
05 101165 RK	RRT-10	Rural Resource Transition-1(Single Family Res-Combo	
05 124863 RK	RRT-10	Rural Resource Transition-1(Single Family Res-Combo	
05 101027 RK	RRT-10	Rural Resource Transition-1(Single Family Res-Combo	
05 120873 RK	RRT-10	Rural Resource Transition-1(Single Family Res-Combo	
05 116875 RK	RRT-10	Rural Resource Transition-1(Single Family Res-Combo	
05 116877 RK	RRT-10	Rural Resource Transition-1(Single Family Res-Combo	
05 122081 RK	RRT-10	Rural Resource Transition-1(Single Family Res-Combo	
05 118380 RK	RRT-10	Rural Resource Transition-1(Single Family Res-Combo	
05 118190 RK	RRT-10	Rural Resource Transition-1(Single Family Res-Combo	
05 118192 RK	RRT-10	Rural Resource Transition-1(Single Family Res-Combo	
04 121469 RK	RRT-10	Rural Resource Transition-1(Single Family Res-Combo	
05 118384 RK	RRT-10	Rural Resource Transition-1(Single Family Res-Combo	
05 120053 RK	RRT-10	Rural Resource Transition-1(Single Family Res-Combo	
05 120077 RK	RRT-10	Rural Resource Transition-1(Single Family Res-Combo	
05 116558 RK	RRT-10	Rural Resource Transition-1(Single Family Res-Combo	
05 100973 RK	RRT-10	Rural Resource Transition-1(Single Family Res-Combo	
04 121470 RK	RRT-10	Rural Resource Transition-1(Single Family Res-Combo	
05 117569 RK	RRT-10	Rural Resource Transition-1(Single Family Res-Combo	
05 126529 RK	RRT-10	Rural Resource Transition-1(Single Family Res-Combo	
05 120069 RK	RRT-10	Rural Resource Transition-1(Single Family Res-Combo	



Accessory Dwelling Units

Index # - File Name: 1.0022 - Single Family Dwellings Data\_Snohomish County.pdf

05 118336 RK	RRT-10	Rural Resource Transition-1(Single Family Res-Combo	
05 125900 RK	RRT-10	Rural Resource Transition-1(Single Family Res-Combo	
05 100296 RK	RRT-10	Rural Resource Transition-1(Single Family Res-Combo	
05 100308 RK	RRT-10	Rural Resource Transition-1(Single Family Res-Combo	
05 117629 RK	RRT-10	Rural Resource Transition-1(SFR-Basic	
05 119959 RK	RRT-10	Rural Resource Transition-1(Single Family Res-Combo	
05 128159 RK	RRT-10	Rural Resource Transition-1(Single Family Res-Combo	
05 117627 RK	RRT-10	Rural Resource Transition-1(SFR-Basic	
05 100477 RK	RRT-10	Rural Resource Transition-1(SFR-Basic	
05 100476 RK	RRT-10	Rural Resource Transition-1(SFR-Basic	
05 116412 RK	RRT-10	Rural Resource Transition-1(Single Family Res-Combo	
05 122032 RK	R-7,200	Residential 7,200 sq. ft.	Single Family Res-Combo
05 102051 RK	R-7,200	Residential 7,200 sq. ft.	SFR-Basic
05 118452 RK	R-7,200	Residential 7,200 sq. ft.	SFR-Basic
05 100086 RK	R-7,200	Residential 7,200 sq. ft.	SFR-Basic
05 126402 RK	R-7,200	Residential 7,200 sq. ft.	SFR-Basic
05 126405 RK	R-7,200	Residential 7,200 sq. ft.	SFR-Basic
05 123228 RK	R-7,200	Residential 7,200 sq. ft.	SFR-Basic
05 125867 RK	R-7,200	Residential 7,200 sq. ft.	SFR-Basic
05 124822 RK	R-7,200	Residential 7,200 sq. ft.	SFR-Basic
05 122195 RK	R-7,200	Residential 7,200 sq. ft.	SFR-Basic
04 121271 RK	R-7,200	Residential 7,200 sq. ft.	SFR-Basic
05 119519 RK	R-7,200	Residential 7,200 sq. ft.	SFR-Basic
05 119750 RK	R-7,200	Residential 7,200 sq. ft.	SFR-Basic
05 119044 RK	R-7,200	Residential 7,200 sq. ft.	SFR-Basic
05 121582 RK	R-7,200	Residential 7,200 sq. ft.	SFR-Basic
04 121270 RK	R-7,200	Residential 7,200 sq. ft.	SFR-Basic
04 117387 RK	R-7,200	Residential 7,200 sq. ft.	SFR-Basic
05 123932 RK	R-5	Rural-5 Acre	Single Family Res-Combo
05 120903 RK	R-7,200	Residential 7,200 sq. ft.	SFR-Basic
05 125246 RK	R-7,200	Residential 7,200 sq. ft.	SFR-Basic
05 121382 RK	R-7,200	Residential 7,200 sq. ft.	SFR-Basic
05 117327 RK	R-7,200	Residential 7,200 sq. ft.	SFR-Basic
05 127764 RK	R-7,200	Residential 7,200 sq. ft.	SFR-Basic
05 121579 RK	R-7,200	Residential 7,200 sq. ft.	SFR-Basic
05 122977 RK	R-7,200	Residential 7,200 sq. ft.	SFR-Basic
05 128733 RK	R-7,200	Residential 7,200 sq. ft.	SFR-Basic
05 116644 RK	R-7,200	Residential 7,200 sq. ft.	SFR-Basic
05 125245 RK	R-7,200	Residential 7,200 sq. ft.	SFR-Basic
05 126572 RK	R-7,200	Residential 7,200 sq. ft.	SFR-Basic
05 101523 RK	R-5	Rural-5 Acre	Single Family Res-Combo
05 122186 RK	LDMR	Low Density Multiple Reside	SFR-Basic
05 122187 RK	LDMR	Low Density Multiple Reside	SFR-Basic
05 121610 RK	PRD-9,600	Residential 9,600 sq. ft.	Single Family Res-Combo
05 101903 RK	PRD-9,600	Residential 9,600 sq. ft.	Single Family Res-Combo
04 120727 RK	PRD-9,600	Residential 9,600 sq. ft.	Single Family Res-Combo
05 101907 RK	PRD-9,600	Residential 9,600 sq. ft.	Single Family Res-Combo

Accessory Dwelling Units

Index # - File Name: 1.0022 - Single Family Dwellings Data\_Snohomish County.pdf

05 117881 RK	PRD-9,600	Residential 9,600 sq. ft.	Single Family Res-Combo
04 120522 RK	PRD-9,600	Residential 9,600 sq. ft.	Single Family Res-Combo
05 116253 RK	PRD-9,600	Residential 9,600 sq. ft.	Single Family Res-Combo
04 120469 RK	R-5	Rural-5 Acre	Single Family Res-Combo
05 100871 RK	R-5	Rural-5 Acre	SFR-Basic
05 120463 RK	R-7,200	Residential 7,200 sq. ft.	Single Family Res-Combo
05 117516 RK	R-7,200	Residential 7,200 sq. ft.	Single Family Res-Combo
05 116639 RK	R-7,200	Residential 7,200 sq. ft.	Single Family Res-Combo
05 120461 RK	R-7,200	Residential 7,200 sq. ft.	Single Family Res-Combo
05 127697 RK	R-5	Rural-5 Acre	SFR-Basic
05 127699 RK	R-5	Rural-5 Acre	SFR-Basic
05 127944 RK	R-5	Rural-5 Acre	SFR-Basic
05 126864 RK	R-5	Rural-5 Acre	SFR-Basic
05 119860 RK	R-5	Rural-5 Acre	Single Family Res-Combo
05 120732 RK	R-5	Rural-5 Acre	Single Family Res-Combo
05 117894 RK	R-5	Rural-5 Acre	Single Family Res-Combo
05 120730 RK	R-5	Rural-5 Acre	Single Family Res-Combo
05 122804 RK	R-5	Rural-5 Acre	Single Family Res-Combo
05 125021 RK	R-5	Rural-5 Acre	SFR-Basic
05 125024 RK	R-5	Rural-5 Acre	Single Family Res-Combo
05 119854 RK	R-5	Rural-5 Acre	SFR-Basic
05 117033 RK	R-5	Rural-5 Acre	SFR-Basic
05 117899 RK	R-5	Rural-5 Acre	Single Family Res-Combo
05 117029 RK	R-5	Rural-5 Acre	Single Family Res-Combo
05 101091 RK	R-5	Rural-5 Acre	SFR-Basic
04 121451 RK	R-5	Rural-5 Acre	Single Family Res-Combo
04 121468 RK	R-5	Rural-5 Acre	Single Family Res-Combo
05 100861 RK	R-5	Rural-5 Acre	Single Family Res-Combo
04 121447 RK	R-5	Rural-5 Acre	Single Family Res-Combo
04 109993 RK	R-7,200	Residential 7,200 sq. ft.	SFR-Basic
05 122334 RK	R-7,200	Residential 7,200 sq. ft.	Single Family Res-Combo
05 120458 RK	R-7,200	Residential 7,200 sq. ft.	Single Family Res-Combo
05 120460 RK	R-7,200	Residential 7,200 sq. ft.	Single Family Res-Combo
05 100387 RK	R-9,600	Residential 9,600 sq. ft.	Single Family Res-Combo
05 100391 RK	R-9,600	Residential 9,600 sq. ft.	SFR-Basic
05 118461 RK	R-5	Rural-5 Acre	SFR-Basic
05 118460 RK	R-5	Rural-5 Acre	SFR-Basic
04 120866 RK	R-5	Rural-5 Acre	SFR-Basic
04 120864 RK	R-5	Rural-5 Acre	SFR-Basic
04 120863 RK	R-5	Rural-5 Acre	SFR-Basic
05 117838 RK	R-5	Rural-5 Acre	Single Family Res-Combo
05 116195 RK	R-5	Rural-5 Acre	SFR-Basic
05 117834 RK	R-5	Rural-5 Acre	Single Family Res-Combo
05 101029 RK	R-5	Rural-5 Acre	Single Family Res-Combo
05 120450 RK	CITY	City	Single Family Res-Combo
05 122331 RK	R-7,200	Residential 7,200 sq. ft.	Single Family Res-Combo
05 126866 RK	R-5	Rural-5 Acre	SFR-Basic

Accessory Dwelling Units

Index # - File Name: 1.0022 - Single Family Dwellings Data\_Snohomish County.pdf

05 116640 RK	R-7,200	Residential 7,200 sq. ft.	Single Family Res-Combo
04 114703 RK	MR	Multiple Residential	Duplex-Combo
06 125810 RK	R-9,600	Residential 9,600 sq. ft.	Single Family Res-Combo
06 125812 RK	R-9,600	Residential 9,600 sq. ft.	Single Family Res-Combo
06 103151 RK	R-5	Rural-5 Acre	SFR-Basic
06 126291 RK	R-5	Rural-5 Acre	SFR-Basic
06 130402 RK	R-5	Rural-5 Acre	SFR-Basic
06 129858 RK	R-7,200	Residential 7,200 sq. ft.	SFR-Basic
06 129859 RK	R-7,200	Residential 7,200 sq. ft.	SFR-Basic
06 127852 RK	R-7,200	Residential 7,200 sq. ft.	SFR-Basic
06 125937 RK	R-7,200	Residential 7,200 sq. ft.	SFR-Basic
06 125936 RK	R-7,200	Residential 7,200 sq. ft.	SFR-Basic
06 133404 RK	R-7,200	Residential 7,200 sq. ft.	SFR-Basic
06 133405 RK	R-7,200	Residential 7,200 sq. ft.	SFR-Basic
06 128618 RK	R-7,200	Residential 7,200 sq. ft.	SFR-Basic
06 130403 RK	R-7,200	Residential 7,200 sq. ft.	SFR-Basic
06 131041 RK	R-7,200	Residential 7,200 sq. ft.	SFR-Basic
06 130404 RK	R-7,200	Residential 7,200 sq. ft.	SFR-Basic
06 127203 RK	R-5	Rural-5 Acre	SFR-Basic
06 127855 RK	R-5	Rural-5 Acre	SFR-Basic
06 126950 RK	R-5	Rural-5 Acre	SFR-Basic
06 127204 RK	R-5	Rural-5 Acre	SFR-Basic
06 127858 RK	R-5	Rural-5 Acre	SFR-Basic
06 103152 RK	R-5	Rural-5 Acre	SFR-Basic
06 131862 RK	R-5	Rural-5 Acre	SFR-Basic
06 127860 RK	R-5	Rural-5 Acre	SFR-Basic
06 128103 RK	R-5	Rural-5 Acre	SFR-Basic
06 103477 RK	R-5	Rural-5 Acre	SFR-Basic
06 128104 RK	R-5	Rural-5 Acre	SFR-Basic
06 133452 RK	R-5	Rural-5 Acre	SFR-Basic
06 127859 RK	R-5	Rural-5 Acre	SFR-Basic
06 128102 RK	R-5	Rural-5 Acre	SFR-Basic
06 131863 RK	R-5	Rural-5 Acre	SFR-Basic
06 101996 RK	R-5	Rural-5 Acre	Single Family Res-Combo
06 102293 RK	R-5	Rural-5 Acre	Single Family Res-Combo
06 102232 RK	R-5	Rural-5 Acre	Single Family Res-Combo
06 126297 RK	R-7,200	Residential 7,200 sq. ft.	SFR-Basic
06 133133 RK	R-7,200	Residential 7,200 sq. ft.	SFR-Basic
06 102718 RK	R-5	Rural-5 Acre	Single Family Res-Combo
06 102571 RK	R-5	Rural-5 Acre	Single Family Res-Combo
06 102914 RK	R-5	Rural-5 Acre	Single Family Res-Combo
06 129701 RK	R-5	Rural-5 Acre	Single Family Res-Combo
06 129699 RK	R-5	Rural-5 Acre	Single Family Res-Combo
06 129963 RK	R-5	Rural-5 Acre	Single Family Res-Combo
06 102649 MH	R-5	Rural-5 Acre	Double Wide
06 104088 RK	R-5	Rural-5 Acre	Single Family Res-Combo
06 130583 RK	R-12,500	Residential 12,500 sq. ft.	Single Family Res-Combo

Accessory Dwelling Units

Index # - File Name: 1.0022 - Single Family Dwellings Data\_Snohomish County.pdf

06 103354 RK	R-5	Rural-5 Acre	Single Family Res-Combo
06 103363 RK	R-5	Rural-5 Acre	Single Family Res-Combo
06 125096 RK	R-5	Rural-5 Acre	SFR-Basic
06 125300 RK	R-5	Rural-5 Acre	SFR-Basic
06 125095 RK	R-5	Rural-5 Acre	SFR-Basic
06 128499 RK	R-5	Rural-5 Acre	Single Family Res-Combo
05 128168 RK	R-7,200	Residential 7,200 sq. ft.	Single Family Res-Combo
06 126449 RK	R-7,200	Residential 7,200 sq. ft.	SFR-Basic
06 125614 RK	R-7,200	Residential 7,200 sq. ft.	SFR-Basic
06 126448 RK	R-7,200	Residential 7,200 sq. ft.	SFR-Basic
06 126447 RK	R-7,200	Residential 7,200 sq. ft.	SFR-Basic
06 129566 RK	R-5	Rural-5 Acre	SFR-Basic
06 131829 RK	R-7,200	Residential 7,200 sq. ft.	SFR-Basic
06 131644 RK	R-7,200	Residential 7,200 sq. ft.	SFR-Basic
06 131647 RK	R-7,200	Residential 7,200 sq. ft.	SFR-Basic
06 130524 RK	R-7,200	Residential 7,200 sq. ft.	SFR-Basic
06 134212 RK	R-7,200	Residential 7,200 sq. ft.	SFR-Basic
06 132454 RK	R-7,200	Residential 7,200 sq. ft.	SFR-Basic
06 133067 RK	R-7,200	Residential 7,200 sq. ft.	SFR-Basic
06 133069 RK	R-7,200	Residential 7,200 sq. ft.	SFR-Basic
06 131440 RK	R-7,200	Residential 7,200 sq. ft.	SFR-Basic
06 132325 RK	R-7,200	Residential 7,200 sq. ft.	SFR-Basic
06 135490 RK	R-7,200	Residential 7,200 sq. ft.	SFR-Basic
06 131437 RK	R-7,200	Residential 7,200 sq. ft.	SFR-Basic
06 131438 RK	R-7,200	Residential 7,200 sq. ft.	SFR-Basic
06 131439 RK	R-7,200	Residential 7,200 sq. ft.	SFR-Basic
06 130427 RK	CITY	City	SFR-Basic
06 130425 RK	CITY	City	SFR-Basic
06 103912 RK	F	Forestry	Single Family Res-Combo
06 103922 RK	R-5	Rural-5 Acre	Single Family Res-Combo
06 126662 RK	R-7,200	Residential 7,200 sq. ft.	SFR-Basic
06 125972 RK	R-7,200	Residential 7,200 sq. ft.	SFR-Basic
06 126369 RK	R-7,200	Residential 7,200 sq. ft.	SFR-Basic
06 126651 RK	R-7,200	Residential 7,200 sq. ft.	SFR-Basic
06 125973 RK	R-7,200	Residential 7,200 sq. ft.	SFR-Basic
06 125974 RK	R-7,200	Residential 7,200 sq. ft.	SFR-Basic
06 126655 RK	R-7,200	Residential 7,200 sq. ft.	SFR-Basic
06 126652 RK	R-7,200	Residential 7,200 sq. ft.	SFR-Basic
06 126653 RK	R-7,200	Residential 7,200 sq. ft.	SFR-Basic
06 126366 RK	R-7,200	Residential 7,200 sq. ft.	SFR-Basic
06 126368 RK	R-7,200	Residential 7,200 sq. ft.	SFR-Basic
06 125976 RK	R-7,200	Residential 7,200 sq. ft.	SFR-Basic
06 104106 RK	R-5	Rural-5 Acre	SFR-Basic
06 104049 RK	R-5	Rural-5 Acre	SFR-Basic
06 131977 RK	LDMM	Low Density Multiple Reside	Single Family Res-Combo
06 131885 RK	LDMM	Low Density Multiple Reside	Single Family Res-Combo
06 131979 RK	LDMM	Low Density Multiple Reside	Single Family Res-Combo

Accessory Dwelling Units

Index # - File Name: 1.0022 - Single Family Dwellings Data\_Snohomish County.pdf

06 132117 RK	LDMR	Low Density Multiple Reside Single Family Res-Combo
06 132118 RK	LDMR	Low Density Multiple Reside Single Family Res-Combo
06 132120 RK	LDMR	Low Density Multiple Reside Single Family Res-Combo
06 131884 RK	LDMR	Low Density Multiple Reside Single Family Res-Combo
06 131980 RK	LDMR	Low Density Multiple Reside Single Family Res-Combo
06 131883 RK	LDMR	Low Density Multiple Reside Single Family Res-Combo
06 131978 RK	LDMR	Low Density Multiple Reside Single Family Res-Combo
06 132121 RK	LDMR	Low Density Multiple Reside Single Family Res-Combo
06 132123 RK	LDMR	Low Density Multiple Reside Single Family Res-Combo
06 135127 RK	LDMR	Low Density Multiple Reside Single Family Res-Combo
06 132668 RK	LDMR	Low Density Multiple Reside SFR-Basic
06 132669 RK	LDMR	Low Density Multiple Reside SFR-Basic
06 132670 RK	LDMR	Low Density Multiple Reside SFR-Basic
06 132671 RK	LDMR	Low Density Multiple Reside SFR-Basic
06 132672 RK	LDMR	Low Density Multiple Reside SFR-Basic
06 132673 RK	LDMR	Low Density Multiple Reside SFR-Basic
06 132674 RK	LDMR	Low Density Multiple Reside SFR-Basic
06 132675 RK	LDMR	Low Density Multiple Reside SFR-Basic
06 132676 RK	LDMR	Low Density Multiple Reside SFR-Basic
06 132959 RK	LDMR	Low Density Multiple Reside SFR-Basic
06 132960 RK	LDMR	Low Density Multiple Reside SFR-Basic
06 132961 RK	LDMR	Low Density Multiple Reside SFR-Basic
06 132962 RK	LDMR	Low Density Multiple Reside SFR-Basic
06 132963 RK	LDMR	Low Density Multiple Reside SFR-Basic
06 132966 RK	LDMR	Low Density Multiple Reside SFR-Basic
06 127943 RK	R-5	Rural-5 Acre Single Family Res-Combo
06 124923 RK	R-5	Rural-5 Acre SFR-Basic
06 124924 RK	R-5	Rural-5 Acre SFR-Basic
06 126006 RK	LDMR	Low Density Multiple Reside SFR-Basic
06 126007 RK	LDMR	Low Density Multiple Reside SFR-Basic
06 126008 RK	LDMR	Low Density Multiple Reside SFR-Basic
06 126009 RK	LDMR	Low Density Multiple Reside SFR-Basic
06 126010 RK	LDMR	Low Density Multiple Reside SFR-Basic
06 126011 RK	LDMR	Low Density Multiple Reside SFR-Basic
06 126012 RK	LDMR	Low Density Multiple Reside SFR-Basic
06 126013 RK	LDMR	Low Density Multiple Reside SFR-Basic
06 126014 RK	LDMR	Low Density Multiple Reside SFR-Basic
06 126015 RK	LDMR	Low Density Multiple Reside SFR-Basic
06 126016 RK	LDMR	Low Density Multiple Reside SFR-Basic
06 126017 RK	LDMR	Low Density Multiple Reside SFR-Basic
06 126018 RK	LDMR	Low Density Multiple Reside SFR-Basic
06 129765 RK	R-7,200	Residential 7,200 sq. ft. SFR-Basic
06 129766 RK	R-7,200	Residential 7,200 sq. ft. SFR-Basic
06 134373 RK	R-7,200	Residential 7,200 sq. ft. SFR-Basic
06 132030 RK	R-7,200	Residential 7,200 sq. ft. SFR-Basic
06 132031 RK	R-7,200	Residential 7,200 sq. ft. SFR-Basic
06 132033 RK	R-7,200	Residential 7,200 sq. ft. SFR-Basic

Accessory Dwelling Units

Index # - File Name: 1.0022 - Single Family Dwellings Data\_Snohomish County.pdf

06 132032 RK	R-7,200	Residential 7,200 sq. ft.	SFR-Basic
06 129767 RK	R-7,200	Residential 7,200 sq. ft.	SFR-Basic
06 129768 RK	R-7,200	Residential 7,200 sq. ft.	SFR-Basic
06 133077 RK	R-7,200	Residential 7,200 sq. ft.	Single Family Res-Combo
06 133943 RK	R-7,200	Residential 7,200 sq. ft.	Single Family Res-Combo
06 134133 RK	R-7,200	Residential 7,200 sq. ft.	Single Family Res-Combo
06 131822 RK	R-7,200	Residential 7,200 sq. ft.	SFR-Basic
06 134135 RK	R-7,200	Residential 7,200 sq. ft.	Single Family Res-Combo
06 133078 RK	R-7,200	Residential 7,200 sq. ft.	Single Family Res-Combo
06 131821 RK	R-7,200	Residential 7,200 sq. ft.	SFR-Basic
06 133079 RK	R-7,200	Residential 7,200 sq. ft.	Single Family Res-Combo
06 130364 RK	R-7,200	Residential 7,200 sq. ft.	SFR-Basic
06 132074 RK	R-7,200	Residential 7,200 sq. ft.	SFR-Basic
06 132075 RK	R-7,200	Residential 7,200 sq. ft.	SFR-Basic
06 132076 RK	R-7,200	Residential 7,200 sq. ft.	SFR-Basic
06 132077 RK	R-7,200	Residential 7,200 sq. ft.	SFR-Basic
06 132078 RK	R-7,200	Residential 7,200 sq. ft.	SFR-Basic
06 132079 RK	R-7,200	Residential 7,200 sq. ft.	SFR-Basic
06 133629 RK	R-7,200	Residential 7,200 sq. ft.	Single Family Res-Combo
06 132080 RK	R-7,200	Residential 7,200 sq. ft.	SFR-Basic
06 132081 RK	R-7,200	Residential 7,200 sq. ft.	SFR-Basic
06 132082 RK	R-7,200	Residential 7,200 sq. ft.	SFR-Basic
06 132083 RK	R-7,200	Residential 7,200 sq. ft.	SFR-Basic
06 133167 RK	R-7,200	Residential 7,200 sq. ft.	SFR-Basic
06 134377 RK	R-7,200	Residential 7,200 sq. ft.	SFR-Basic
06 125120 RK	R-9,600	Residential 9,600 sq. ft.	Single Family Res-Combo
06 131828 RK	R-5	Rural-5 Acre	Single Family Res-Combo
06 125210 RK	R-5	Rural-5 Acre	Single Family Res-Combo
06 126422 RK	R-5	Rural-5 Acre	Single Family Res-Combo
06 133169 RK	R-7,200	Residential 7,200 sq. ft.	SFR-Basic
06 133019 RK	R-7,200	Residential 7,200 sq. ft.	SFR-Basic
06 132996 RK	R-7,200	Residential 7,200 sq. ft.	Single Family Res-Combo
06 132470 RK	R-7,200	Residential 7,200 sq. ft.	Single Family Res-Combo
06 135175 RK	R-7,200	Residential 7,200 sq. ft.	SFR-Basic
06 135174 RK	R-7,200	Residential 7,200 sq. ft.	SFR-Basic
06 135684 RK	R-7,200	Residential 7,200 sq. ft.	SFR-Basic
06 133447 RK	R-7,200	Residential 7,200 sq. ft.	SFR-Basic
06 125577 RK	R-5	Rural-5 Acre	SFR-Basic
06 126830 RK	LDMR	Low Density Multiple Reside	Single Family Res-Combo
06 129584 RK	LDMR	Low Density Multiple Reside	SFR-Basic
06 128723 RK	LDMR	Low Density Multiple Reside	SFR-Basic
06 128724 RK	LDMR	Low Density Multiple Reside	SFR-Basic
06 129585 RK	LDMR	Low Density Multiple Reside	SFR-Basic
06 128607 RK	LDMR	Low Density Multiple Reside	SFR-Basic
06 128614 RK	LDMR	Low Density Multiple Reside	SFR-Basic
06 129586 RK	LDMR	Low Density Multiple Reside	SFR-Basic
06 128616 RK	LDMR	Low Density Multiple Reside	SFR-Basic

Accessory Dwelling Units

Index # - File Name: 1.0022 - Single Family Dwellings Data\_Snohomish County.pdf

06 129587 RK	LDMR	Low Density Multiple Reside	SFR-Basic
06 128612 RK	LDMR	Low Density Multiple Reside	SFR-Basic
06 129588 RK	LDMR	Low Density Multiple Reside	SFR-Basic
06 128610 RK	LDMR	Low Density Multiple Reside	SFR-Basic
06 128617 RK	LDMR	Low Density Multiple Reside	SFR-Basic
06 129589 RK	LDMR	Low Density Multiple Reside	SFR-Basic
06 128609 RK	LDMR	Low Density Multiple Reside	SFR-Basic
06 128619 RK	LDMR	Low Density Multiple Reside	SFR-Basic
06 129590 RK	LDMR	Low Density Multiple Reside	SFR-Basic
06 128613 RK	LDMR	Low Density Multiple Reside	SFR-Basic
06 131201 RK	LDMR	Low Density Multiple Reside	SFR-Basic
06 131202 RK	LDMR	Low Density Multiple Reside	SFR-Basic
06 131203 RK	LDMR	Low Density Multiple Reside	SFR-Basic
06 131204 RK	LDMR	Low Density Multiple Reside	SFR-Basic
06 131205 RK	LDMR	Low Density Multiple Reside	SFR-Basic
06 131207 RK	LDMR	Low Density Multiple Reside	SFR-Basic
06 131208 RK	LDMR	Low Density Multiple Reside	SFR-Basic
06 131209 RK	LDMR	Low Density Multiple Reside	SFR-Basic
06 125575 RK	CITY	City	SFR-Basic
06 128490 RK	R-5	Rural-5 Acre	Single Family Res-Combo
06 133944 RK	R-7,200	Residential 7,200 sq. ft.	Single Family Res-Combo
06 135026 RK	R-7,200	Residential 7,200 sq. ft.	Single Family Res-Combo
06 132162 RK	R-7,200	Residential 7,200 sq. ft.	SFR-Basic
06 125803 MH	R-5	Rural-5 Acre	Double Wide
06 126085 RK	R-5	Rural-5 Acre	Single Family Res-Combo
06 126134 RK	R-5	Rural-5 Acre	Single Family Res-Combo
06 125875 RK	R-5	Rural-5 Acre	Single Family Res-Combo
06 135345 RK	CITY	City	SFR-Basic
06 135346 RK	CITY	City	SFR-Basic
06 135347 RK	CITY	City	SFR-Basic
06 135337 RK	CITY	City	SFR-Basic
06 135338 RK	CITY	City	SFR-Basic
06 135339 RK	CITY	City	SFR-Basic
06 135340 RK	CITY	City	SFR-Basic
06 135342 RK	CITY	City	SFR-Basic
06 127096 RK	MR	Multiple Residential	SFR-Basic
06 127097 RK	MR	Multiple Residential	SFR-Basic
06 127098 RK	MR	Multiple Residential	SFR-Basic
06 126885 RK	MR	Multiple Residential	SFR-Basic
06 126887 RK	MR	Multiple Residential	SFR-Basic
06 126884 RK	MR	Multiple Residential	SFR-Basic
06 126883 RK	MR	Multiple Residential	SFR-Basic
06 129912 RK	MR	Multiple Residential	Duplex-Basic
06 130619 RK	MR	Multiple Residential	SFR-Basic
06 130620 RK	MR	Multiple Residential	SFR-Basic
06 130621 RK	MR	Multiple Residential	SFR-Basic
06 130622 RK	MR	Multiple Residential	SFR-Basic

Accessory Dwelling Units

Index # - File Name: 1.0022 - Single Family Dwellings Data\_Snohomish County.pdf

06 130623 RK	MR	Multiple Residential	SFR-Basic
06 129403 RK	MR	Multiple Residential	SFR-Basic
06 129921 RK	MR	Multiple Residential	SFR-Basic
06 128542 RK	MR	Multiple Residential	SFR-Basic
06 129922 RK	MR	Multiple Residential	SFR-Basic
06 128544 RK	MR	Multiple Residential	SFR-Basic
06 128543 RK	MR	Multiple Residential	SFR-Basic
06 126286 RK	R-9,600	Residential 9,600 sq. ft.	Single Family Res-Combo
06 130617 RK	MR	Multiple Residential	SFR-Basic
06 130618 RK	MR	Multiple Residential	SFR-Basic
06 130624 RK	MR	Multiple Residential	SFR-Basic
06 130625 RK	MR	Multiple Residential	SFR-Basic
06 130626 RK	MR	Multiple Residential	SFR-Basic
06 130627 RK	MR	Multiple Residential	Duplex-Basic
06 127091 RK	MR	Multiple Residential	SFR-Basic
06 127092 RK	MR	Multiple Residential	SFR-Basic
06 127094 RK	MR	Multiple Residential	SFR-Basic
06 126650 RK	R-5	Rural-5 Acre	Single Family Res-Combo
06 126846 RK	R-5	Rural-5 Acre	Single Family Res-Combo
06 126711 RK	R-5	Rural-5 Acre	Single Family Res-Combo
06 131865 RK	R-5	Rural-5 Acre	Single Family Res-Combo
06 133522 RK	R-5	Rural-5 Acre	Single Family Res-Combo
06 133336 RK	CITY	City	SFR-Basic
06 133242 RK	CITY	City	SFR-Basic
06 133240 RK	CITY	City	SFR-Basic
06 133241 RK	CITY	City	SFR-Basic
05 124480 RK	R-5	Rural-5 Acre	Single Family Res-Combo
06 127006 RK	R-5	Rural-5 Acre	Single Family Res-Combo
06 129001 RK	R-7,200	Residential 7,200 sq. ft.	SFR-Basic
06 130687 RK	R-7,200	Residential 7,200 sq. ft.	Single Family Res-Combo
06 130686 RK	R-7,200	Residential 7,200 sq. ft.	Single Family Res-Combo
06 129004 RK	R-7,200	Residential 7,200 sq. ft.	SFR-Basic
06 130685 RK	R-7,200	Residential 7,200 sq. ft.	Single Family Res-Combo
06 129176 RK	CITY	City	Single Family Res-Combo
06 129179 RK	CITY	City	Single Family Res-Combo
06 126991 RK	R-5	Rural-5 Acre	Single Family Res-Combo
06 129206 RK	A-10	Agriculture-10 Acre	Single Family Res-Combo
06 131969 RK	R-5	Rural-5 Acre	Single Family Res-Combo
06 130318 RK	CITY	City	SFR-Basic
06 130316 RK	CITY	City	SFR-Basic
06 130317 RK	CITY	City	SFR-Basic
06 130319 RK	CITY	City	SFR-Basic
06 130322 RK	CITY	City	SFR-Basic
06 130324 RK	CITY	City	SFR-Basic
06 130325 RK	CITY	City	SFR-Basic
06 130323 RK	CITY	City	SFR-Basic
06 131943 RK	CITY	City	SFR-Basic



Accessory Dwelling Units

Index # - File Name: 1.0022 - Single Family Dwellings Data\_Snohomish County.pdf

06 131849 RK	CITY	City	SFR-Basic
06 131826 RK	PCB	Planned Community Business	SFR-Basic
06 131824 RK	CITY	City	SFR-Basic
06 131850 RK	CITY	City	SFR-Basic
06 127230 RK	A-10	Agriculture-10 Acre	Single Family Res-Combo
06 129175 RK	CITY	City	Single Family Res-Combo
06 133321 RK	CITY	City	SFR-Basic
06 133322 RK	CITY	City	SFR-Basic
06 130353 RK	CITY	City	SFR-Basic
06 130899 RK	CITY	City	SFR-Basic
06 130098 RK	CITY	City	SFR-Basic
06 130354 RK	CITY	City	SFR-Basic
06 130355 RK	CITY	City	SFR-Basic
06 130099 RK	CITY	City	SFR-Basic
06 134182 RK	CITY	City	SFR-Basic
06 135029 RK	CITY	City	SFR-Basic
06 133035 RK	CITY	City	SFR-Basic
06 130348 RK	CITY	City	SFR-Basic
06 134569 RK	CITY	City	SFR-Basic
06 133931 RK	CITY	City	SFR-Basic
06 133036 RK	CITY	City	SFR-Basic
06 135030 RK	CITY	City	SFR-Basic
06 134778 RK	CITY	City	SFR-Basic
06 135464 RK	CITY	City	SFR-Basic
06 130352 RK	CITY	City	SFR-Basic
06 132052 RK	CITY	City	SFR-Basic
06 134568 RK	CITY	City	SFR-Basic
06 130060 RK	R-7,200	Residential 7,200 sq. ft.	SFR-Basic
06 131445 RK	R-7,200	Residential 7,200 sq. ft.	SFR-Basic
06 131443 RK	R-7,200	Residential 7,200 sq. ft.	SFR-Basic
06 130061 RK	R-7,200	Residential 7,200 sq. ft.	SFR-Basic
06 127914 MH	A-10	Agriculture-10 Acre	Triple Wide
06 127688 RK	LDMR	Low Density Multiple Residence	SFR-Basic
06 129114 RK	LDMR	Low Density Multiple Residence	SFR-Basic
06 129115 RK	LDMR	Low Density Multiple Residence	SFR-Basic
06 129116 RK	LDMR	Low Density Multiple Residence	SFR-Basic
06 128513 RK	PRD-9,600	Residential 9,600 sq. ft.	SFR-Basic
06 128118 RK	PRD-9,600	Residential 9,600 sq. ft.	SFR-Basic
06 128119 RK	PRD-9,600	Residential 9,600 sq. ft.	SFR-Basic
06 128122 RK	PRD-9,600	Residential 9,600 sq. ft.	SFR-Basic
06 128120 RK	PRD-9,600	Residential 9,600 sq. ft.	SFR-Basic
06 128121 RK	PRD-9,600	Residential 9,600 sq. ft.	SFR-Basic
06 128123 RK	PRD-9,600	Residential 9,600 sq. ft.	SFR-Basic
06 128394 RK	PRD-9,600	Residential 9,600 sq. ft.	SFR-Basic
06 128124 RK	PRD-9,600	Residential 9,600 sq. ft.	SFR-Basic
06 128514 RK	PRD-9,600	Residential 9,600 sq. ft.	SFR-Basic
06 128519 RK	PRD-9,600	Residential 9,600 sq. ft.	SFR-Basic

Accessory Dwelling Units

Index # - File Name: 1.0022 - Single Family Dwellings Data\_Snohomish County.pdf

06 129120 RK	PRD-9,600	Residential 9,600 sq. ft.	SFR-Basic
06 128516 RK	PRD-9,600	Residential 9,600 sq. ft.	SFR-Basic
06 128515 RK	PRD-9,600	Residential 9,600 sq. ft.	SFR-Basic
06 129121 RK	PRD-9,600	Residential 9,600 sq. ft.	SFR-Basic
06 128520 RK	PRD-9,600	Residential 9,600 sq. ft.	SFR-Basic
06 128518 RK	PRD-9,600	Residential 9,600 sq. ft.	SFR-Basic
06 128517 RK	PRD-9,600	Residential 9,600 sq. ft.	SFR-Basic
06 129122 RK	PRD-9,600	Residential 9,600 sq. ft.	SFR-Basic
06 128521 RK	PRD-9,600	Residential 9,600 sq. ft.	SFR-Basic
06 129123 RK	PRD-9,600	Residential 9,600 sq. ft.	SFR-Basic
06 129124 RK	PRD-9,600	Residential 9,600 sq. ft.	SFR-Basic
06 129059 RK	PRD-9,600	Residential 9,600 sq. ft.	SFR-Basic
06 129209 RK	PRD-9,600	Residential 9,600 sq. ft.	SFR-Basic
06 129210 RK	PRD-9,600	Residential 9,600 sq. ft.	SFR-Basic
06 129211 RK	PRD-9,600	Residential 9,600 sq. ft.	SFR-Basic
06 129212 RK	PRD-9,600	Residential 9,600 sq. ft.	SFR-Basic
06 129213 RK	PRD-9,600	Residential 9,600 sq. ft.	SFR-Basic
06 129214 RK	PRD-9,600	Residential 9,600 sq. ft.	SFR-Basic
06 129254 RK	PRD-9,600	Residential 9,600 sq. ft.	SFR-Basic
06 129255 RK	PRD-9,600	Residential 9,600 sq. ft.	SFR-Basic
06 129256 RK	PRD-9,600	Residential 9,600 sq. ft.	SFR-Basic
06 129257 RK	PRD-9,600	Residential 9,600 sq. ft.	SFR-Basic
06 129258 RK	PRD-9,600	Residential 9,600 sq. ft.	SFR-Basic
06 129308 RK	PRD-9,600	Residential 9,600 sq. ft.	SFR-Basic
06 129309 RK	PRD-9,600	Residential 9,600 sq. ft.	SFR-Basic
06 129310 RK	PRD-9,600	Residential 9,600 sq. ft.	SFR-Basic
06 129311 RK	PRD-9,600	Residential 9,600 sq. ft.	SFR-Basic
06 129312 RK	PRD-9,600	Residential 9,600 sq. ft.	SFR-Basic
06 129313 RK	PRD-9,600	Residential 9,600 sq. ft.	SFR-Basic
06 129108 RK	LDMR	Low Density Multiple Reside	SFR-Basic
06 129110 RK	LDMR	Low Density Multiple Reside	SFR-Basic
06 129111 RK	LDMR	Low Density Multiple Reside	SFR-Basic
06 127690 RK	LDMR	Low Density Multiple Reside	SFR-Basic
06 127691 RK	LDMR	Low Density Multiple Reside	SFR-Basic
06 127692 RK	LDMR	Low Density Multiple Reside	SFR-Basic
06 127693 RK	LDMR	Low Density Multiple Reside	SFR-Basic
06 127694 RK	LDMR	Low Density Multiple Reside	SFR-Basic
06 130033 RK	LDMR	Low Density Multiple Reside	SFR-Basic
06 129112 RK	LDMR	Low Density Multiple Reside	SFR-Basic
06 130034 RK	LDMR	Low Density Multiple Reside	SFR-Basic
06 129113 RK	LDMR	Low Density Multiple Reside	SFR-Basic
06 127695 RK	LDMR	Low Density Multiple Reside	SFR-Basic
06 127696 RK	LDMR	Low Density Multiple Reside	SFR-Basic
06 135211 RK	PRD-9,600	Residential 9,600 sq. ft.	SFR-Basic
06 135212 RK	PRD-9,600	Residential 9,600 sq. ft.	SFR-Basic
06 135213 RK	PRD-9,600	Residential 9,600 sq. ft.	SFR-Basic
06 135214 RK	PRD-9,600	Residential 9,600 sq. ft.	SFR-Basic

Accessory Dwelling Units

Index # - File Name: 1.0022 - Single Family Dwellings Data\_Snohomish County.pdf

06 135215 RK	PRD-9,600	Residential 9,600 sq. ft.	SFR-Basic
06 135216 RK	PRD-9,600	Residential 9,600 sq. ft.	SFR-Basic
06 135217 RK	PRD-9,600	Residential 9,600 sq. ft.	SFR-Basic
06 134036 RK	PRD-9,600	Residential 9,600 sq. ft.	SFR-Basic
06 134037 RK	PRD-9,600	Residential 9,600 sq. ft.	SFR-Basic
06 134038 RK	PRD-9,600	Residential 9,600 sq. ft.	SFR-Basic
06 134039 RK	PRD-9,600	Residential 9,600 sq. ft.	SFR-Basic
06 134040 RK	PRD-9,600	Residential 9,600 sq. ft.	SFR-Basic
06 134041 RK	PRD-9,600	Residential 9,600 sq. ft.	SFR-Basic
06 134042 RK	PRD-9,600	Residential 9,600 sq. ft.	SFR-Basic
06 131075 RK	PRD-9,600	Residential 9,600 sq. ft.	SFR-Basic
06 131076 RK	PRD-9,600	Residential 9,600 sq. ft.	SFR-Basic
06 131078 RK	PRD-9,600	Residential 9,600 sq. ft.	SFR-Basic
06 131079 RK	PRD-9,600	Residential 9,600 sq. ft.	SFR-Basic
06 131080 RK	PRD-9,600	Residential 9,600 sq. ft.	SFR-Basic
06 131081 RK	PRD-9,600	Residential 9,600 sq. ft.	SFR-Basic
06 131082 RK	PRD-9,600	Residential 9,600 sq. ft.	SFR-Basic
06 131132 RK	PRD-9,600	Residential 9,600 sq. ft.	SFR-Basic
06 131133 RK	PRD-9,600	Residential 9,600 sq. ft.	SFR-Basic
06 131134 RK	PRD-9,600	Residential 9,600 sq. ft.	SFR-Basic
06 131135 RK	PRD-9,600	Residential 9,600 sq. ft.	SFR-Basic
06 127545 RK	R-5	Rural-5 Acre	Single Family Res-Combo
06 128091 RK	R-12,500	Residential 12,500 sq. ft.	Single Family Res-Combo
06 131996 RK	MR	Multiple Residential	Duplex-Combo
06 128310 RK	LDMR	Low Density Multiple Reside	Duplex-Basic
06 132416 RK	R-5	Rural-5 Acre	Single Family Res-Combo
06 128368 RK	CITY	City	Single Family Res-Combo
06 133075 RK	R-5	Rural-5 Acre	Single Family Res-Combo
06 131053 RK	R-5	Rural-5 Acre	Single Family Res-Combo
06 131873 RK	R-5	Rural-5 Acre	Single Family Res-Combo
06 131055 RK	R-5	Rural-5 Acre	Single Family Res-Combo
06 128392 RK	LDMR	Low Density Multiple Reside	Duplex-Combo
06 130134 RK	R-7,200	Residential 7,200 sq. ft.	SFR-Basic
06 130136 RK	R-7,200	Residential 7,200 sq. ft.	SFR-Basic
06 131811 RK	R-5	Rural-5 Acre	Single Family Res-Combo
06 132070 RK	R-7,200	Residential 7,200 sq. ft.	SFR-Basic
06 134804 RK	R-7,200	Residential 7,200 sq. ft.	SFR-Basic
06 132072 RK	R-7,200	Residential 7,200 sq. ft.	SFR-Basic
06 134806 RK	R-7,200	Residential 7,200 sq. ft.	SFR-Basic
06 132073 RK	R-7,200	Residential 7,200 sq. ft.	SFR-Basic
06 128555 RK	R-5	Rural-5 Acre	Single Family Res-Combo
06 128528 RK	R-5	Rural-5 Acre	Single Family Res-Combo
06 128637 RK	RRT-10	Rural Resource Transition-10	Single Family Res-Combo
06 130224 MH	R-5	Rural-5 Acre	Double Wide
06 131805 RK	R-5	Rural-5 Acre	Single Family Res-Combo
06 134803 RK	R-7,200	Residential 7,200 sq. ft.	SFR-Basic
06 132067 RK	R-7,200	Residential 7,200 sq. ft.	SFR-Basic

Accessory Dwelling Units

Index # - File Name: 1.0022 - Single Family Dwellings Data\_Snohomish County.pdf

06 132068 RK	R-7,200	Residential 7,200 sq. ft.	SFR-Basic
06 131061 RK	R-7,200	Residential 7,200 sq. ft.	SFR-Basic
06 131056 RK	R-7,200	Residential 7,200 sq. ft.	Single Family Res-Combo
06 131060 RK	R-7,200	Residential 7,200 sq. ft.	SFR-Basic
06 131059 RK	R-7,200	Residential 7,200 sq. ft.	SFR-Basic
06 131058 RK	R-7,200	Residential 7,200 sq. ft.	Single Family Res-Combo
06 134805 RK	R-7,200	Residential 7,200 sq. ft.	SFR-Basic
06 134548 RK	LDMR	Low Density Multiple Reside	SFR-Basic
06 132071 RK	R-7,200	Residential 7,200 sq. ft.	SFR-Basic
06 132066 RK	R-7,200	Residential 7,200 sq. ft.	Single Family Res-Combo
06 132069 RK	R-7,200	Residential 7,200 sq. ft.	SFR-Basic
06 129278 RK	R-5	Rural-5 Acre	Single Family Res-Combo
06 133220 RK	R-7,200(PRD)	Residential 7,200 sq. ft.	SFR-Basic
06 133223 RK	R-7,200(PRD)	Residential 7,200 sq. ft.	SFR-Basic
06 133224 RK	R-7,200(PRD)	Residential 7,200 sq. ft.	SFR-Basic
06 133222 RK	R-7,200(PRD)	Residential 7,200 sq. ft.	SFR-Basic
06 133226 RK	R-7,200(PRD)	Residential 7,200 sq. ft.	SFR-Basic
06 129547 RK	R-5	Rural-5 Acre	Single Family Res-Combo
06 133305 RK	F	Forestry	Single Family Res-Combo
06 133229 RK	R-7,200(PRD)	Residential 7,200 sq. ft.	SFR-Basic
06 133230 RK	R-7,200(PRD)	Residential 7,200 sq. ft.	SFR-Basic
06 133231 RK	R-7,200(PRD)	Residential 7,200 sq. ft.	SFR-Basic
06 133227 RK	R-7,200(PRD)	Residential 7,200 sq. ft.	SFR-Basic
06 133228 RK	R-7,200(PRD)	Residential 7,200 sq. ft.	SFR-Basic
06 134360 RK	CITY	City	SFR-Basic
06 133280 RK	CITY	City	SFR-Basic
06 133281 RK	CITY	City	SFR-Basic
06 134358 RK	CITY	City	SFR-Basic
06 132999 RK	R-7,200	Residential 7,200 sq. ft.	SFR-Basic
06 133001 RK	R-7,200	Residential 7,200 sq. ft.	SFR-Basic
06 135606 RK	R-7,200	Residential 7,200 sq. ft.	SFR-Basic
06 135605 RK	R-7,200	Residential 7,200 sq. ft.	SFR-Basic
06 129690 RK	R-5	Rural-5 Acre	Single Family Res-Combo
06 130417 RK	CITY	City	Single Family Res-Combo
06 130415 RK	CITY	City	Single Family Res-Combo
06 130515 MH	R-5	Rural-5 Acre	Double Wide
06 130514 MH	R-5	Rural-5 Acre	Double Wide
06 130590 RK	R-12,500	Residential 12,500 sq. ft.	Single Family Res-Combo
06 130616 RK	R-12,500	Residential 12,500 sq. ft.	Single Family Res-Combo
06 130628 RK	R-12,500	Residential 12,500 sq. ft.	Single Family Res-Combo
06 133821 RK	R-7,200	Residential 7,200 sq. ft.	SFR-Basic
06 133823 RK	R-7,200	Residential 7,200 sq. ft.	SFR-Basic
06 133824 RK	R-7,200	Residential 7,200 sq. ft.	SFR-Basic
06 133825 RK	R-7,200	Residential 7,200 sq. ft.	SFR-Basic
06 133826 RK	R-7,200	Residential 7,200 sq. ft.	SFR-Basic
06 133827 RK	R-7,200	Residential 7,200 sq. ft.	SFR-Basic
06 133828 RK	R-7,200	Residential 7,200 sq. ft.	SFR-Basic

Accessory Dwelling Units

Index # - File Name: 1.0022 - Single Family Dwellings Data\_Snohomish County.pdf

06 133829 RK	R-7,200	Residential 7,200 sq. ft.	SFR-Basic
06 133830 RK	R-7,200	Residential 7,200 sq. ft.	SFR-Basic
06 133822 RK	R-7,200	Residential 7,200 sq. ft.	SFR-Basic
06 135458 RK	R-7,200	Residential 7,200 sq. ft.	SFR-Basic
06 132585 RK	R-7,200(PRD)	Residential 7,200 sq. ft.	SFR-Basic
06 133187 RK	A-10	Agriculture-10 Acre	Single Family Res-Combo
06 131298 RK	R-5	Rural-5 Acre	Single Family Res-Combo
06 131364 RK	R-5	Rural-5 Acre	SFR-Basic
06 132579 RK	R-7,200(PRD)	Residential 7,200 sq. ft.	SFR-Basic
06 132580 RK	R-7,200(PRD)	Residential 7,200 sq. ft.	SFR-Basic
06 132578 RK	R-7,200(PRD)	Residential 7,200 sq. ft.	SFR-Basic
06 132581 RK	R-7,200(PRD)	Residential 7,200 sq. ft.	SFR-Basic
06 132582 RK	R-7,200(PRD)	Residential 7,200 sq. ft.	SFR-Basic
06 132587 RK	R-7,200(PRD)	Residential 7,200 sq. ft.	SFR-Basic
06 132584 RK	R-7,200(PRD)	Residential 7,200 sq. ft.	SFR-Basic
06 135693 RK	R-9,600	Residential 9,600 sq. ft.	SFR-Basic
06 131794 RK	R-5	Rural-5 Acre	SFR-Basic
06 134421 RK	MR	Multiple Residential	SFR-Basic
06 134423 RK	MR	Multiple Residential	SFR-Basic
06 135000 RK	R-7,200	Residential 7,200 sq. ft.	SFR-Basic
06 134422 RK	MR	Multiple Residential	SFR-Basic
06 133809 RK	R-7,200	Residential 7,200 sq. ft.	SFR-Basic
06 133138 RK	R-5	Rural-5 Acre	Single Family Res-Combo
06 134996 RK	R-7,200	Residential 7,200 sq. ft.	SFR-Basic
06 134997 RK	R-7,200	Residential 7,200 sq. ft.	SFR-Basic
06 134998 RK	R-7,200	Residential 7,200 sq. ft.	SFR-Basic
06 134999 RK	R-7,200	Residential 7,200 sq. ft.	SFR-Basic
06 134447 RK	R-7,200	Residential 7,200 sq. ft.	SFR-Basic
06 133497 RK	R-5	Rural-5 Acre	SFR-Basic
06 134438 RK	R-5	Rural-5 Acre	Single Family Res-Combo
06 132595 RK	R-5	Rural-5 Acre	Single Family Res-Combo
06 134991 RK	R-7,200	Residential 7,200 sq. ft.	Single Family Res-Combo
06 134984 RK	R-7,200	Residential 7,200 sq. ft.	Single Family Res-Combo
06 134989 RK	R-7,200	Residential 7,200 sq. ft.	Single Family Res-Combo
06 134980 RK	R-7,200	Residential 7,200 sq. ft.	Single Family Res-Combo
06 134987 RK	R-7,200	Residential 7,200 sq. ft.	Single Family Res-Combo
06 133495 RK	R-5	Rural-5 Acre	Single Family Res-Combo
06 134337 RK	CITY	City	SFR-Basic
06 134340 RK	CITY	City	SFR-Basic
06 134341 RK	CITY	City	SFR-Basic
06 134342 RK	CITY	City	SFR-Basic
06 134343 RK	CITY	City	SFR-Basic
06 134344 RK	CITY	City	SFR-Basic
06 134345 RK	CITY	City	SFR-Basic
06 134346 RK	CITY	City	SFR-Basic
06 134338 RK	CITY	City	SFR-Basic
06 134339 RK	CITY	City	SFR-Basic

Accessory Dwelling Units

Index # - File Name: 1.0022 - Single Family Dwellings Data\_Snohomish County.pdf

06 135617 RK	R-8,400	Residential 8,400 sq. ft.	SFR-Basic
06 135616 RK	R-8,400	Residential 8,400 sq. ft.	SFR-Basic
06 101098 RK	A-10	Agriculture-10 Acre	Single Family Res-Combo
06 134797 RK	R-5	Rural-5 Acre	Single Family Res-Combo
06 134747 RK	R-5	Rural-5 Acre	Single Family Res-Combo
06 125685 RK	R-5	Rural-5 Acre	SFR-Basic
04 116654 000 01 RK	R-9,600	Residential 9,600 sq. ft.	Single Family Res-Combo
06 101073 RK	F	Forestry	Single Family Res-Combo
06 100043 RK	R-5	Rural-5 Acre	Accessory Apt Detached-Combo
06 100644 RK	R-5	Rural-5 Acre	SFR-Basic
06 125303 RK	R-5	Rural-5 Acre	SFR-Basic
06 100640 RK	R-5	Rural-5 Acre	SFR-Basic
06 130577 RK	R-7,200	Residential 7,200 sq. ft.	SFR-Basic
06 132413 RK	R-7,200	Residential 7,200 sq. ft.	SFR-Basic
06 127765 RK	R-7,200	Residential 7,200 sq. ft.	SFR-Basic
06 133022 RK	R-7,200	Residential 7,200 sq. ft.	SFR-Basic
06 101542 RK	R-7,200	Residential 7,200 sq. ft.	SFR-Basic
06 103146 RK	R-7,200	Residential 7,200 sq. ft.	SFR-Basic
06 102102 RK	R-7,200	Residential 7,200 sq. ft.	SFR-Basic
06 103145 RK	R-7,200	Residential 7,200 sq. ft.	SFR-Basic
06 132716 RK	R-7,200	Residential 7,200 sq. ft.	SFR-Basic
06 126184 RK	R-7,200	Residential 7,200 sq. ft.	SFR-Basic
06 126844 RK	R-7,200	Residential 7,200 sq. ft.	SFR-Basic
06 133020 RK	R-7,200	Residential 7,200 sq. ft.	SFR-Basic
06 125653 RK	R-7,200	Residential 7,200 sq. ft.	SFR-Basic
06 126183 RK	R-7,200	Residential 7,200 sq. ft.	SFR-Basic
06 100055 RK	R-7,200	Residential 7,200 sq. ft.	SFR-Basic
06 133021 RK	R-7,200	Residential 7,200 sq. ft.	SFR-Basic
06 127344 RK	R-7,200	Residential 7,200 sq. ft.	SFR-Basic
06 126845 RK	R-7,200	Residential 7,200 sq. ft.	SFR-Basic
06 104122 RK	R-7,200	Residential 7,200 sq. ft.	SFR-Basic
06 132715 RK	R-7,200	Residential 7,200 sq. ft.	SFR-Basic
06 127766 RK	R-7,200	Residential 7,200 sq. ft.	SFR-Basic
06 102898 RK	R-5	Rural-5 Acre	Single Family Res-Combo
06 100576 RK	R-5	Rural-5 Acre	Single Family Res-Combo
06 103262 RK	RRT-10	Rural Resource Transition-1	Single Family Res-Combo
05 125787 RK	RRT-10	Rural Resource Transition-1	Single Family Res-Combo
05 123253 RK	RRT-10	Rural Resource Transition-1	Single Family Res-Combo
06 104081 RK	RRT-10	Rural Resource Transition-1	SFR-Basic
05 129106 RK	RRT-10	Rural Resource Transition-1	SFR-Basic
06 127269 RK	RRT-10	Rural Resource Transition-1	Single Family Res-Combo
06 102198 RK	RRT-10	Rural Resource Transition-1	Single Family Res-Combo
04 111269 000 01 RK	R-5	Rural-5 Acre	Single Family Res-Combo
05 128484 RK	R-5	Rural-5 Acre	Single Family Res-Combo
05 129022 RK	R-7,200	Residential 7,200 sq. ft.	SFR-Basic
06 100020 RK	R-7,200	Residential 7,200 sq. ft.	SFR-Basic
06 100023 RK	R-7,200	Residential 7,200 sq. ft.	SFR-Basic

Accessory Dwelling Units

Index # - File Name: 1.0022 - Single Family Dwellings Data\_Snohomish County.pdf

05 129025 RK	R-7,200	Residential 7,200 sq. ft.	SFR-Basic
06 102510 RK	R-5	Rural-5 Acre	Single Family Res-Combo
06 102567 RK	R-5	Rural-5 Acre	Single Family Res-Combo
06 134043 MH	MHP	Mobile Home Park	MH Park-Double Wide
06 125118 RK	R-5	Rural-5 Acre	Single Family Res-Combo
06 100589 RK	R-5	Rural-5 Acre	SFR-Basic
05 128574 RK	R-5	Rural-5 Acre	SFR-Basic
05 128963 RK	R-5	Rural-5 Acre	SFR-Basic
06 102923 RK	R-5	Rural-5 Acre	Single Family Res-Combo
05 126632 RK	R-9,600	Residential 9,600 sq. ft.	Single Family Res-Combo
06 125172 RK	R-9,600	Residential 9,600 sq. ft.	Single Family Res-Combo
06 125175 RK	R-9,600	Residential 9,600 sq. ft.	Single Family Res-Combo
03 110472 000 01 MH	R-5	Rural-5 Acre	Triple Wide
06 100878 RK	R-9,600	Residential 9,600 sq. ft.	Single Family Res-Combo
06 129461 RK	R-8,400	Residential 8,400 sq. ft.	Single Family Res-Combo
05 128983 RK	A-10	Agriculture-10 Acre	Single Family Res-Combo
04 115438 000 02 RK	R-5	Rural-5 Acre	Single Family Res-Combo
06 103212 RK	R-5	Rural-5 Acre	Single Family Res-Combo
05 127943 RK	R-5	Rural-5 Acre	Single Family Res-Combo
06 132846 RK	R-5	Rural-5 Acre	Single Family Res-Combo
06 101017 RK	R-5	Rural-5 Acre	Single Family Res-Combo
03 108772 000 01 RK	A-10 : R-5	Agriculture-10 Acre : Rural-5	Single Family Res-Combo
06 133385 RK	R-5	Rural-5 Acre	Single Family Res-Combo
06 103259 RK	R-5	Rural-5 Acre	Single Family Res-Combo
06 129805 RK	CITY	City	Single Family Res-Combo
06 131458 RK	R-5	Rural-5 Acre	Single Family Res-Combo
06 100587 RK	R-5	Rural-5 Acre	SFR-Basic
06 130145 RK	PRD-7,200	Residential 7,200 sq. ft.	SFR-Basic
06 101730 RK	R-5	Rural-5 Acre	Single Family Res-Combo
05 129078 RK	R-5	Rural-5 Acre	Single Family Res-Combo
05 124957 RK	R-5	Rural-5 Acre	Single Family Res-Combo
05 126244 RK	R-5	Rural-5 Acre	Single Family Res-Combo
06 101897 RK	R-5	Rural-5 Acre	Single Family Res-Combo
06 102575 RK	R-9,600	Residential 9,600 sq. ft.	Single Family Res-Combo
06 130841 RK	R-5	Rural-5 Acre	Single Family Res-Combo
05 127588 RK	R-7,200	Residential 7,200 sq. ft.	Single Family Res-Combo
06 127459 RK	R-5	Rural-5 Acre	Single Family Res-Combo
04 109089 000 01 RK	R-5	Rural-5 Acre	Single Family Res-Combo
06 133647 RK	CITY	City	SFR-Basic
06 133650 RK	CITY	City	SFR-Basic
06 133651 RK	CITY	City	SFR-Basic
06 128061 RK	CITY	City	Single Family Res-Combo
05 127604 RK	R-5	Rural-5 Acre	Single Family Res-Combo
06 128550 RK	R-7,200	Residential 7,200 sq. ft.	SFR-Basic
06 130526 RK	R-7,200	Residential 7,200 sq. ft.	SFR-Basic
05 127714 RK	R-5	Rural-5 Acre	Single Family Res-Combo
06 126612 RK	R-5	Rural-5 Acre	Single Family Res-Combo

Accessory Dwelling Units

Index # - File Name: 1.0022 - Single Family Dwellings Data\_Snohomish County.pdf

05 128115 RK	MR	Multiple Residential	Duplex-Basic
06 102625 RK	MR	Multiple Residential	Duplex-Basic
06 100889 RK	MR	Multiple Residential	Duplex-Basic
06 100891 RK	MR	Multiple Residential	Single Family Res-Combo
06 129234 RK	MR	Multiple Residential	Duplex-Basic
06 129235 RK	MR	Multiple Residential	Duplex-Basic
06 129236 RK	MR	Multiple Residential	Duplex-Basic
05 128309 RK	MR	Multiple Residential	Duplex-Basic
05 128308 RK	MR	Multiple Residential	Duplex-Basic
06 100175 RK	R-5	Rural-5 Acre	Single Family Res-Combo
06 100407 RK	CITY	City	SFR-Basic
06 100408 RK	CITY	City	SFR-Basic
06 126607 RK	CITY	City	SFR-Basic
06 126784 RK	CITY	City	SFR-Basic
06 126608 RK	CITY	City	SFR-Basic
05 127704 RK	R-12,500	Residential 12,500 sq. ft.	Single Family Res-Combo
05 127707 RK	R-12,500	Residential 12,500 sq. ft.	Single Family Res-Combo
05 127706 RK	R-12,500	Residential 12,500 sq. ft.	Single Family Res-Combo
06 128575 RK	CITY	City	SFR-Basic
06 128572 RK	CITY	City	SFR-Basic
06 128573 RK	CITY	City	SFR-Basic
06 128574 RK	CITY	City	SFR-Basic
06 130048 RK	CITY	City	SFR-Basic
06 104067 RK	CITY	City	SFR-Basic
06 102231 RK	MR	Multiple Residential	Duplex-Basic
06 102230 RK	MR	Multiple Residential	Duplex-Basic
06 103456 RK	R-7,200	Residential 7,200 sq. ft.	Single Family Res-Combo
06 129692 RK	R-7,200	Residential 7,200 sq. ft.	SFR-Basic
06 129693 RK	R-7,200	Residential 7,200 sq. ft.	SFR-Basic
06 133534 RK	R-7,200	Residential 7,200 sq. ft.	SFR-Basic
06 129694 RK	R-7,200	Residential 7,200 sq. ft.	SFR-Basic
06 103455 RK	R-7,200	Residential 7,200 sq. ft.	Single Family Res-Combo
06 128597 RK	R-7,200	Residential 7,200 sq. ft.	SFR-Basic
06 134513 RK	MR	Multiple Residential	SFR-Basic
06 134813 RK	MR	Multiple Residential	SFR-Basic
06 134632 RK	MR	Multiple Residential	SFR-Basic
06 134820 RK	MR	Multiple Residential	SFR-Basic
06 134817 RK	MR	Multiple Residential	SFR-Basic
06 134823 RK	MR	Multiple Residential	SFR-Basic
06 134822 RK	MR	Multiple Residential	SFR-Basic
06 134633 RK	MR	Multiple Residential	SFR-Basic
05 127244 RK	R-7,200	Residential 7,200 sq. ft.	Single Family Res-Combo
05 127242 RK	R-7,200	Residential 7,200 sq. ft.	Single Family Res-Combo
05 127245 RK	R-7,200	Residential 7,200 sq. ft.	Single Family Res-Combo
06 101127 RK	R-5 : R-7,200	Residential 7,200 sq. ft. : Ru	SFR-Basic
06 101613 RK	R-5 : R-7,200	Residential 7,200 sq. ft. : Ru	SFR-Basic
06 101616 RK	R-5 : R-7,200	Residential 7,200 sq. ft. : Ru	SFR-Basic



Accessory Dwelling Units

Index # - File Name: 1.0022 - Single Family Dwellings Data\_Snohomish County.pdf

06 101124 RK	R-5 : R-7,200	Residential 7,200 sq. ft. :	Ru1 SFR-Basic
06 101617 RK	R-5 : R-7,200	Residential 7,200 sq. ft. :	Ru1 SFR-Basic
06 101407 RK	R-5 : R-7,200	Residential 7,200 sq. ft. :	Ru1 SFR-Basic
06 101618 RK	R-5 : R-7,200	Residential 7,200 sq. ft. :	Ru1 SFR-Basic
06 101405 RK	R-5 : R-7,200	Residential 7,200 sq. ft. :	Ru1 SFR-Basic
06 101619 RK	R-5 : R-7,200	Residential 7,200 sq. ft. :	Ru1 SFR-Basic
06 101624 RK	R-5 : R-7,200	Residential 7,200 sq. ft. :	Ru1 SFR-Basic
06 102290 RK	R-5 : R-7,200	Residential 7,200 sq. ft. :	Ru1 SFR-Basic
06 102289 RK	R-5 : R-7,200	Residential 7,200 sq. ft. :	Ru1 SFR-Basic
06 102288 RK	R-5 : R-7,200	Residential 7,200 sq. ft. :	Ru1 SFR-Basic
06 133717 RK	R-5 : R-7,200	Residential 7,200 sq. ft. :	Ru1 SFR-Basic
06 102287 RK	R-5 : R-7,200	Residential 7,200 sq. ft. :	Ru1 SFR-Basic
06 102285 RK	R-5 : R-7,200	Residential 7,200 sq. ft. :	Ru1 SFR-Basic
06 102275 RK	R-5 : R-7,200	Residential 7,200 sq. ft. :	Ru1 SFR-Basic
06 101609 RK	R-5 : R-7,200	Residential 7,200 sq. ft. :	Ru1 SFR-Basic
06 102284 RK	R-5 : R-7,200	Residential 7,200 sq. ft. :	Ru1 SFR-Basic
06 135403 RK	R-5 : R-7,200	Residential 7,200 sq. ft. :	Ru1 SFR-Basic
06 101625 RK	R-5 : R-7,200	Residential 7,200 sq. ft. :	Ru1 SFR-Basic
06 102277 RK	R-5 : R-7,200	Residential 7,200 sq. ft. :	Ru1 SFR-Basic
06 101627 RK	R-5 : R-7,200	Residential 7,200 sq. ft. :	Ru1 SFR-Basic
06 100446 RK	R-5 : R-7,200	Residential 7,200 sq. ft. :	Ru1 SFR-Basic
05 128605 RK	R-5	Rural-5 Acre	Single Family Res-Combo
06 100409 RK	R-7,200(PRD)	Residential 7,200 sq. ft.	SFR-Basic
06 100412 RK	R-7,200(PRD)	Residential 7,200 sq. ft.	SFR-Basic
06 100413 RK	R-7,200(PRD)	Residential 7,200 sq. ft.	SFR-Basic
06 100410 RK	R-7,200(PRD)	Residential 7,200 sq. ft.	SFR-Basic
06 104064 RK	R-7,200(PRD)	Residential 7,200 sq. ft.	SFR-Basic
06 104065 RK	R-7,200(PRD)	Residential 7,200 sq. ft.	SFR-Basic
06 104066 RK	R-7,200(PRD)	Residential 7,200 sq. ft.	SFR-Basic
06 100415 RK	R-7,200(PRD)	Residential 7,200 sq. ft.	SFR-Basic
06 100411 RK	R-7,200(PRD)	Residential 7,200 sq. ft.	SFR-Basic
06 100416 RK	R-7,200(PRD)	Residential 7,200 sq. ft.	SFR-Basic
06 100414 RK	R-7,200(PRD)	Residential 7,200 sq. ft.	SFR-Basic
06 128577 RK	R-7,200(PRD)	Residential 7,200 sq. ft.	SFR-Basic
06 128576 RK	R-7,200(PRD)	Residential 7,200 sq. ft.	SFR-Basic
06 127105 RK	R-7,200(PRD)	Residential 7,200 sq. ft.	SFR-Basic
06 102544 RK	R-7,200(PRD)	Residential 7,200 sq. ft.	SFR-Basic
06 102543 RK	R-7,200(PRD)	Residential 7,200 sq. ft.	SFR-Basic
06 129756 RK	R-7,200(PRD)	Residential 7,200 sq. ft.	SFR-Basic
06 129757 RK	R-7,200(PRD)	Residential 7,200 sq. ft.	SFR-Basic
06 129758 RK	R-7,200(PRD)	Residential 7,200 sq. ft.	SFR-Basic
06 129759 RK	R-7,200(PRD)	Residential 7,200 sq. ft.	SFR-Basic
06 101805 RK	R-7,200	Residential 7,200 sq. ft.	SFR-Basic
06 101810 RK	R-7,200	Residential 7,200 sq. ft.	SFR-Basic
06 102412 RK	R-7,200	Residential 7,200 sq. ft.	SFR-Basic
06 101814 RK	R-7,200	Residential 7,200 sq. ft.	SFR-Basic
06 102411 RK	R-7,200	Residential 7,200 sq. ft.	SFR-Basic

Accessory Dwelling Units

Index # - File Name: 1.0022 - Single Family Dwellings Data\_Snohomish County.pdf

06 102413 RK	R-7,200	Residential 7,200 sq. ft.	SFR-Basic
06 102414 RK	R-7,200	Residential 7,200 sq. ft.	SFR-Basic
06 131307 RK	R-7,200	Residential 7,200 sq. ft.	SFR-Basic
06 128571 RK	CITY	City	SFR-Basic
06 130030 RK	CITY	City	SFR-Basic
06 130041 RK	CITY	City	SFR-Basic
06 130042 RK	CITY	City	SFR-Basic
06 130043 RK	CITY	City	SFR-Basic
06 130044 RK	CITY	City	SFR-Basic
06 130045 RK	CITY	City	SFR-Basic
06 130046 RK	CITY	City	SFR-Basic
06 130047 RK	CITY	City	SFR-Basic
06 104063 RK	CITY	City	SFR-Basic
06 104070 RK	CITY	City	SFR-Basic
06 101020 RK	R-7,200(PRD)	Residential 7,200 sq. ft.	SFR-Basic
06 131033 RK	R-5	Rural-5 Acre	SFR-Basic
06 125698 RK	A-10	Agriculture-10 Acre	Single Family Res-Combo
06 129960 RK	R-5	Rural-5 Acre	SFR-Basic
06 132450 RK	R-5	Rural-5 Acre	SFR-Basic
06 129964 RK	R-5	Rural-5 Acre	SFR-Basic
06 132510 RK	R-5	Rural-5 Acre	SFR-Basic
05 127455 MH	F	Forestry	Triple Wide
06 102385 RK	CITY	City	SFR-Basic
06 101144 RK	CITY	City	SFR-Basic
06 102388 RK	CITY	City	SFR-Basic
06 102396 RK	CITY	City	SFR-Basic
06 102395 RK	CITY	City	Duplex-Basic
06 103757 RK	CITY	City	Single Family Res-Combo
06 102390 RK	CITY	City	SFR-Basic
06 101146 RK	CITY	City	SFR-Basic
06 102394 RK	CITY	City	SFR-Basic
06 101147 RK	CITY	City	SFR-Basic
06 102389 RK	CITY	City	SFR-Basic
06 101149 RK	CITY	City	SFR-Basic
06 102387 RK	CITY	City	SFR-Basic
06 101150 RK	CITY	City	SFR-Basic
06 102386 RK	CITY	City	SFR-Basic
06 103247 RK	CITY	City	SFR-Basic
06 101151 RK	CITY	City	SFR-Basic
06 102384 RK	CITY	City	SFR-Basic
06 101152 RK	CITY	City	SFR-Basic
06 126165 RK	CITY	City	SFR-Basic
06 102392 RK	CITY	City	SFR-Basic
06 103245 RK	CITY	City	SFR-Basic
06 102391 RK	CITY	City	SFR-Basic
06 103244 RK	CITY	City	SFR-Basic
06 101153 RK	CITY	City	SFR-Basic

Accessory Dwelling Units

Index # - File Name: 1.0022 - Single Family Dwellings Data\_Snohomish County.pdf

06 126167 RK	CITY	City	SFR-Basic
06 101154 RK	CITY	City	SFR-Basic
06 103246 RK	CITY	City	SFR-Basic
06 102393 RK	CITY	City	SFR-Basic
06 126166 RK	CITY	City	SFR-Basic
06 102397 RK	CITY	City	SFR-Basic
06 103248 RK	CITY	City	SFR-Basic
05 127557 MH	R-5	Rural-5 Acre	Double Wide
05 128204 RK	CITY	City	SFR-Basic
05 128206 RK	CITY	City	SFR-Basic
05 128212 RK	CITY	City	SFR-Basic
05 128214 RK	CITY	City	SFR-Basic
05 128216 RK	CITY	City	SFR-Basic
05 128219 RK	CITY	City	SFR-Basic
05 128220 RK	CITY	City	SFR-Basic
05 128222 RK	CITY	City	SFR-Basic
05 128223 RK	CITY	City	SFR-Basic
06 130333 RK	R-7,200	Residential 7,200 sq. ft.	SFR-Basic
06 131029 RK	R-7,200	Residential 7,200 sq. ft.	SFR-Basic
06 129502 RK	R-7,200	Residential 7,200 sq. ft.	SFR-Basic
06 129500 RK	R-7,200	Residential 7,200 sq. ft.	SFR-Basic
06 130338 RK	R-7,200	Residential 7,200 sq. ft.	SFR-Basic
06 128634 RK	R-7,200	Residential 7,200 sq. ft.	SFR-Basic
06 132037 RK	R-7,200	Residential 7,200 sq. ft.	SFR-Basic
06 127872 RK	R-7,200	Residential 7,200 sq. ft.	SFR-Basic
06 100687 RK	R-7,200(PRD)	Residential 7,200 sq. ft.	SFR-Basic
06 100688 RK	R-7,200(PRD)	Residential 7,200 sq. ft.	SFR-Basic
06 102008 RK	R-7,200(PRD)	Residential 7,200 sq. ft.	SFR-Basic
06 102009 RK	R-7,200(PRD)	Residential 7,200 sq. ft.	SFR-Basic
06 103069 RK	R-7,200(PRD)	Residential 7,200 sq. ft.	SFR-Basic
06 103070 RK	R-7,200(PRD)	Residential 7,200 sq. ft.	SFR-Basic
06 124997 RK	R-7,200(PRD)	Residential 7,200 sq. ft.	SFR-Basic
06 128672 RK	R-7,200(PRD)	Residential 7,200 sq. ft.	SFR-Basic
06 130884 RK	R-7,200(PRD)	Residential 7,200 sq. ft.	SFR-Basic
06 130883 RK	R-7,200(PRD)	Residential 7,200 sq. ft.	SFR-Basic
06 131941 RK	R-7,200(PRD)	Residential 7,200 sq. ft.	SFR-Basic
06 131942 RK	R-7,200(PRD)	Residential 7,200 sq. ft.	SFR-Basic
06 130104 RK	R-7,200(PRD)	Residential 7,200 sq. ft.	SFR-Basic
06 102660 RK	R-7,200(PRD)	Residential 7,200 sq. ft.	SFR-Basic
06 126589 RK	R-7,200(PRD)	Residential 7,200 sq. ft.	SFR-Basic
06 130062 RK	R-7,200(PRD)	Residential 7,200 sq. ft.	SFR-Basic
06 102658 RK	R-7,200(PRD)	Residential 7,200 sq. ft.	SFR-Basic
06 126588 RK	R-7,200(PRD)	Residential 7,200 sq. ft.	SFR-Basic
06 102659 RK	R-7,200(PRD)	Residential 7,200 sq. ft.	SFR-Basic
06 125619 RK	R-7,200(PRD)	Residential 7,200 sq. ft.	SFR-Basic
06 125620 RK	R-7,200(PRD)	Residential 7,200 sq. ft.	SFR-Basic
06 124996 RK	R-7,200(PRD)	Residential 7,200 sq. ft.	SFR-Basic

Accessory Dwelling Units

Index # - File Name: 1.0022 - Single Family Dwellings Data\_Snohomish County.pdf

06 125926 RK	R-7,200	Residential 7,200 sq. ft.	SFR-Basic
06 103584 RK	R-7,200	Residential 7,200 sq. ft.	SFR-Basic
06 102702 RK	R-7,200	Residential 7,200 sq. ft.	SFR-Basic
06 102340 RK	R-7,200	Residential 7,200 sq. ft.	SFR-Basic
06 102705 RK	R-7,200	Residential 7,200 sq. ft.	SFR-Basic
05 101665 RK	R-5	Rural-5 Acre	Single Family Res-Combo
06 129079 RK	NB	Neighborhood Business	Single Family Res-Combo
06 103479 RK	R-7,200	Residential 7,200 sq. ft.	Single Family Res-Combo
06 103483 RK	R-7,200	Residential 7,200 sq. ft.	Single Family Res-Combo
06 100610 RK	R-7,200	Residential 7,200 sq. ft.	Single Family Res-Combo
06 100608 RK	R-7,200	Residential 7,200 sq. ft.	Single Family Res-Combo
06 100609 RK	R-7,200	Residential 7,200 sq. ft.	Single Family Res-Combo
06 100611 RK	R-7,200	Residential 7,200 sq. ft.	Single Family Res-Combo
06 125527 RK	R-7,200	Residential 7,200 sq. ft.	Single Family Res-Combo
06 103605 RK	R-7,200	Residential 7,200 sq. ft.	Single Family Res-Combo
06 103917 RK	R-7,200	Residential 7,200 sq. ft.	SFR-Basic
06 103450 RK	R-7,200	Residential 7,200 sq. ft.	SFR-Basic
06 103451 RK	R-7,200	Residential 7,200 sq. ft.	SFR-Basic
06 101112 RK	R-7,200	Residential 7,200 sq. ft.	SFR-Basic
06 101111 RK	R-7,200	Residential 7,200 sq. ft.	SFR-Basic
06 101117 RK	R-7,200	Residential 7,200 sq. ft.	SFR-Basic
06 101113 RK	R-7,200	Residential 7,200 sq. ft.	SFR-Basic
05 128117 RK	R-7,200	Residential 7,200 sq. ft.	SFR-Basic
05 128119 RK	R-7,200	Residential 7,200 sq. ft.	SFR-Basic
06 101115 RK	R-7,200	Residential 7,200 sq. ft.	SFR-Basic
06 101114 RK	R-7,200	Residential 7,200 sq. ft.	SFR-Basic
05 128120 RK	R-7,200	Residential 7,200 sq. ft.	SFR-Basic
05 128118 RK	R-7,200	Residential 7,200 sq. ft.	SFR-Basic
05 129310 RK	R-7,200	Residential 7,200 sq. ft.	SFR-Basic
05 129311 RK	R-7,200	Residential 7,200 sq. ft.	SFR-Basic
05 129312 RK	R-7,200	Residential 7,200 sq. ft.	SFR-Basic
05 129313 RK	R-7,200	Residential 7,200 sq. ft.	SFR-Basic
05 129314 RK	R-7,200	Residential 7,200 sq. ft.	SFR-Basic
06 101108 RK	R-7,200	Residential 7,200 sq. ft.	SFR-Basic
06 101119 RK	R-7,200	Residential 7,200 sq. ft.	SFR-Basic
06 103918 RK	R-7,200	Residential 7,200 sq. ft.	SFR-Basic
06 103919 RK	R-7,200	Residential 7,200 sq. ft.	SFR-Basic
06 101809 RK	R-7,200	Residential 7,200 sq. ft.	Single Family Res-Combo
06 101859 RK	R-7,200	Residential 7,200 sq. ft.	SFR-Basic
06 129613 RK	R-7,200	Residential 7,200 sq. ft.	SFR-Basic
06 131171 RK	R-7,200	Residential 7,200 sq. ft.	SFR-Basic
06 100174 RK	R-7,200	Residential 7,200 sq. ft.	SFR-Basic
06 129615 RK	R-7,200	Residential 7,200 sq. ft.	SFR-Basic
06 101860 RK	R-7,200	Residential 7,200 sq. ft.	Single Family Res-Combo
06 131170 RK	R-7,200	Residential 7,200 sq. ft.	Single Family Res-Combo
06 102558 RK	R-7,200	Residential 7,200 sq. ft.	SFR-Basic
06 101010 RK	R-7,200	Residential 7,200 sq. ft.	SFR-Basic

Accessory Dwelling Units

Index # - File Name: 1.0022 - Single Family Dwellings Data\_Snohomish County.pdf

06 101018 RK	R-7,200	Residential 7,200 sq. ft.	SFR-Basic
06 101642 RK	R-7,200	Residential 7,200 sq. ft.	SFR-Basic
06 101640 RK	R-7,200	Residential 7,200 sq. ft.	SFR-Basic
06 101641 RK	R-7,200	Residential 7,200 sq. ft.	SFR-Basic
05 128978 RK	R-7,200	Residential 7,200 sq. ft.	SFR-Basic
05 128911 RK	R-7,200	Residential 7,200 sq. ft.	SFR-Basic
06 101643 RK	R-7,200	Residential 7,200 sq. ft.	SFR-Basic
05 128913 RK	R-7,200	Residential 7,200 sq. ft.	SFR-Basic
06 129640 RK	R-7,200	Residential 7,200 sq. ft.	SFR-Basic
06 102560 RK	R-7,200	Residential 7,200 sq. ft.	SFR-Basic
06 133106 RK	R-7,200	Residential 7,200 sq. ft.	SFR-Basic
06 134083 RK	R-7,200	Residential 7,200 sq. ft.	SFR-Basic
06 129137 RK	R-7,200	Residential 7,200 sq. ft.	Single Family Res-Combo
06 129138 RK	R-7,200	Residential 7,200 sq. ft.	Single Family Res-Combo
06 134088 RK	R-7,200	Residential 7,200 sq. ft.	SFR-Basic
06 129139 RK	R-7,200	Residential 7,200 sq. ft.	Single Family Res-Combo
06 129140 RK	R-7,200	Residential 7,200 sq. ft.	Single Family Res-Combo
06 129142 RK	R-7,200	Residential 7,200 sq. ft.	Single Family Res-Combo
06 125439 RK	MR	Multiple Residential	SFR-Basic
06 125940 RK	MR	Multiple Residential	SFR-Basic
06 125716 RK	MR	Multiple Residential	SFR-Basic
06 127207 RK	MR	Multiple Residential	SFR-Basic
06 125717 RK	MR	Multiple Residential	SFR-Basic
06 127208 RK	MR	Multiple Residential	SFR-Basic
06 127199 RK	MR	Multiple Residential	SFR-Basic
06 125718 RK	MR	Multiple Residential	SFR-Basic
06 127209 RK	MR	Multiple Residential	SFR-Basic
06 127200 RK	MR	Multiple Residential	SFR-Basic
06 129853 RK	MR	Multiple Residential	SFR-Basic
06 132105 RK	MR	Multiple Residential	SFR-Basic
06 104230 RK	MR	Multiple Residential	SFR-Basic
06 104231 RK	MR	Multiple Residential	SFR-Basic
06 129070 RK	MR	Multiple Residential	SFR-Basic
06 131037 RK	MR	Multiple Residential	SFR-Basic
06 103177 RK	MR	Multiple Residential	SFR-Basic
06 132793 RK	MR	Multiple Residential	SFR-Basic
06 103175 RK	MR	Multiple Residential	SFR-Basic
06 127212 RK	MR	Multiple Residential	SFR-Basic
06 127211 RK	MR	Multiple Residential	SFR-Basic
06 129647 RK	R-7,200	Residential 7,200 sq. ft.	SFR-Basic
05 129160 RK	R-7,200	Residential 7,200 sq. ft.	SFR-Basic
06 129641 RK	R-7,200	Residential 7,200 sq. ft.	SFR-Basic
05 129351 RK	R-7,200	Residential 7,200 sq. ft.	SFR-Basic
06 129637 RK	R-7,200	Residential 7,200 sq. ft.	SFR-Basic
06 129639 RK	R-7,200	Residential 7,200 sq. ft.	SFR-Basic
06 129635 RK	R-7,200	Residential 7,200 sq. ft.	SFR-Basic
06 102561 RK	R-7,200	Residential 7,200 sq. ft.	SFR-Basic

Accessory Dwelling Units

Index # - File Name: 1.0022 - Single Family Dwellings Data\_Snohomish County.pdf

06 100773 RK	R-5	Rural-5 Acre	Single Family Res-Combo
06 100777 RK	R-5	Rural-5 Acre	SFR-Basic
06 132043 RK	CITY	City	SFR-Basic
06 101263 RK	CITY	City	SFR-Basic
06 101244 RK	CITY	City	SFR-Basic
06 102678 RK	CITY	City	SFR-Basic
06 103333 RK	CITY	City	SFR-Basic
06 127891 RK	CITY	City	Single Family Res-Combo
06 127890 RK	CITY	City	Single Family Res-Combo
06 102679 RK	CITY	City	SFR-Basic
06 102690 RK	CITY	City	SFR-Basic
06 102682 RK	CITY	City	SFR-Basic
06 102681 RK	CITY	City	SFR-Basic
06 102680 RK	CITY	City	SFR-Basic
06 131702 RK	CITY	City	Single Family Res-Combo
06 102683 RK	CITY	City	SFR-Basic
06 127888 RK	CITY	City	Single Family Res-Combo
06 103332 RK	CITY	City	SFR-Basic
06 101248 RK	CITY	City	SFR-Basic
06 101249 RK	CITY	City	SFR-Basic
06 101257 RK	CITY	City	SFR-Basic
06 101258 RK	CITY	City	SFR-Basic
06 101259 RK	CITY	City	SFR-Basic
06 101260 RK	CITY	City	SFR-Basic
06 101261 RK	CITY	City	SFR-Basic
06 101262 RK	CITY	City	SFR-Basic
06 103334 RK	CITY	City	SFR-Basic
06 103335 RK	CITY	City	SFR-Basic
06 103344 RK	CITY	City	SFR-Basic
06 133555 RK	CITY	City	Single Family Res-Combo
06 103350 RK	CITY	City	SFR-Basic
06 103340 RK	CITY	City	SFR-Basic
06 103337 RK	CITY	City	SFR-Basic
06 127889 RK	CITY	City	Single Family Res-Combo
06 103338 RK	CITY	City	SFR-Basic
06 103341 RK	CITY	City	SFR-Basic
06 103339 RK	CITY	City	SFR-Basic
06 131700 RK	CITY	City	SFR-Basic
06 104271 RK	CITY	City	SFR-Basic
06 104272 RK	CITY	City	SFR-Basic
06 134221 RK	R-7,200	Residential 7,200 sq. ft.	SFR-Basic
05 129178 RK	R-5	Rural-5 Acre	Single Family Res-Combo
06 132717 RK	R-7,200	Residential 7,200 sq. ft.	SFR-Basic
06 136064 RK	R-7,200	Residential 7,200 sq. ft.	SFR-Basic
06 134769 RK	R-7,200	Residential 7,200 sq. ft.	SFR-Basic
06 134768 RK	R-7,200	Residential 7,200 sq. ft.	SFR-Basic
06 135493 RK	R-7,200	Residential 7,200 sq. ft.	SFR-Basic

Accessory Dwelling Units

Index # - File Name: 1.0022 - Single Family Dwellings Data\_Snohomish County.pdf

06 131226 RK	R-7,200	Residential 7,200 sq. ft.	SFR-Basic
06 131225 RK	R-7,200	Residential 7,200 sq. ft.	SFR-Basic
06 132718 RK	R-7,200	Residential 7,200 sq. ft.	SFR-Basic
06 135406 RK	R-7,200	Residential 7,200 sq. ft.	SFR-Basic
06 128631 RK	R-7,200	Residential 7,200 sq. ft.	SFR-Basic
06 127683 RK	R-7,200	Residential 7,200 sq. ft.	SFR-Basic
06 127399 RK	R-7,200	Residential 7,200 sq. ft.	SFR-Basic
06 137042 RK	R-7,200	Residential 7,200 sq. ft.	SFR-Basic
06 128328 RK	R-7,200	Residential 7,200 sq. ft.	SFR-Basic
06 126782 RK	R-7,200	Residential 7,200 sq. ft.	SFR-Basic
06 126668 RK	R-7,200	Residential 7,200 sq. ft.	SFR-Basic
06 125879 RK	R-7,200	Residential 7,200 sq. ft.	SFR-Basic
06 125694 RK	R-7,200	Residential 7,200 sq. ft.	SFR-Basic
06 125511 RK	R-7,200	Residential 7,200 sq. ft.	SFR-Basic
06 125193 RK	R-7,200	Residential 7,200 sq. ft.	SFR-Basic
06 100990 RK	R-7,200	Residential 7,200 sq. ft.	SFR-Basic
06 100987 RK	R-7,200	Residential 7,200 sq. ft.	SFR-Basic
06 100985 RK	R-7,200	Residential 7,200 sq. ft.	SFR-Basic
06 127682 RK	R-5	Rural-5 Acre	Single Family Res-Combo
06 103306 RK	RD	Rural Diversification	Single Family Res-Combo
05 128677 RK	RD	Rural Diversification	Single Family Res-Combo
06 128100 RK	MR	Multiple Residential	SFR-Basic
06 100980 RK	MR	Multiple Residential	SFR-Basic
06 102157 RK	MR	Multiple Residential	SFR-Basic
06 103481 RK	MR	Multiple Residential	SFR-Basic
06 125536 RK	MR	Multiple Residential	SFR-Basic
06 126294 RK	MR	Multiple Residential	SFR-Basic
06 126952 RK	MR	Multiple Residential	SFR-Basic
06 129854 RK	MR	Multiple Residential	SFR-Basic
06 132104 RK	MR	Multiple Residential	SFR-Basic
06 132101 RK	MR	Multiple Residential	SFR-Basic
06 128379 RK	RD	Rural Diversification	Single Family Res-Combo
06 131295 RK	RD	Rural Diversification	Single Family Res-Combo
06 133218 RK	RD	Rural Diversification	Single Family Res-Combo
05 128675 RK	RD	Rural Diversification	Single Family Res-Combo
06 103312 RK	RD	Rural Diversification	Single Family Res-Combo
05 128676 RK	RD	Rural Diversification	Single Family Res-Combo
05 125838 RK	R-5	Rural-5 Acre	SFR-Basic
06 124935 RK	LDMR	Low Density Multiple Reside	SFR-Basic
06 124939 RK	LDMR	Low Density Multiple Reside	SFR-Basic
06 124936 RK	LDMR	Low Density Multiple Reside	SFR-Basic
06 124938 RK	LDMR	Low Density Multiple Reside	SFR-Basic
06 102857 RK	R-5	Rural-5 Acre	Single Family Res-Combo
05 127613 RK	R-5	Rural-5 Acre	Single Family Res-Combo
06 127840 RK	MR	Multiple Residential	SFR-Basic
06 127841 RK	MR	Multiple Residential	SFR-Basic
06 132103 RK	MR	Multiple Residential	SFR-Basic

Accessory Dwelling Units

Index # - File Name: 1.0022 - Single Family Dwellings Data\_Snohomish County.pdf

06 133762 RK	MR	Multiple Residential	SFR-Basic
06 134323 RK	MR	Multiple Residential	SFR-Basic
06 134618 RK	MR	Multiple Residential	SFR-Basic
06 126619 RK	MR	Multiple Residential	SFR-Basic
06 126620 RK	MR	Multiple Residential	SFR-Basic
06 126621 RK	MR	Multiple Residential	SFR-Basic
06 125442 RK	MR	Multiple Residential	SFR-Basic
06 125441 RK	MR	Multiple Residential	SFR-Basic
06 127410 RK	MR	Multiple Residential	SFR-Basic
06 127413 RK	MR	Multiple Residential	SFR-Basic
06 126622 RK	MR	Multiple Residential	SFR-Basic
06 126623 RK	MR	Multiple Residential	SFR-Basic
06 127414 RK	MR	Multiple Residential	SFR-Basic
06 127411 RK	MR	Multiple Residential	SFR-Basic
06 127412 RK	MR	Multiple Residential	SFR-Basic
06 126955 RK	MR	Multiple Residential	SFR-Basic
06 126954 RK	MR	Multiple Residential	SFR-Basic
06 126953 RK	MR	Multiple Residential	SFR-Basic
06 127846 RK	MR	Multiple Residential	SFR-Basic
06 125714 RK	MR	Multiple Residential	SFR-Basic
06 125715 RK	MR	Multiple Residential	SFR-Basic
06 127847 RK	MR	Multiple Residential	SFR-Basic
06 128101 RK	MR	Multiple Residential	SFR-Basic
06 103565 RK	R-7,200	Residential 7,200 sq. ft.	SFR-Basic
06 100177 RK	R-7,200	Residential 7,200 sq. ft.	SFR-Basic
06 100178 RK	R-7,200	Residential 7,200 sq. ft.	SFR-Basic
06 100179 RK	R-7,200	Residential 7,200 sq. ft.	SFR-Basic
06 100180 RK	R-7,200	Residential 7,200 sq. ft.	SFR-Basic
06 100181 RK	R-7,200	Residential 7,200 sq. ft.	SFR-Basic
06 100182 RK	R-7,200	Residential 7,200 sq. ft.	SFR-Basic
06 103561 RK	R-7,200	Residential 7,200 sq. ft.	SFR-Basic
06 103562 RK	R-7,200	Residential 7,200 sq. ft.	SFR-Basic
06 103563 RK	R-7,200	Residential 7,200 sq. ft.	SFR-Basic
06 103564 RK	R-7,200	Residential 7,200 sq. ft.	SFR-Basic
06 102905 RK	R-7,200	Residential 7,200 sq. ft.	SFR-Basic
06 102906 RK	R-7,200	Residential 7,200 sq. ft.	SFR-Basic
06 102907 RK	R-7,200	Residential 7,200 sq. ft.	SFR-Basic
06 102908 RK	R-7,200	Residential 7,200 sq. ft.	SFR-Basic
06 102909 RK	R-7,200	Residential 7,200 sq. ft.	SFR-Basic
06 102482 RK	R-7,200	Residential 7,200 sq. ft.	SFR-Basic
06 102483 RK	R-7,200	Residential 7,200 sq. ft.	SFR-Basic
06 102484 RK	R-7,200	Residential 7,200 sq. ft.	SFR-Basic
06 102485 RK	R-7,200	Residential 7,200 sq. ft.	SFR-Basic
06 102486 RK	R-7,200	Residential 7,200 sq. ft.	SFR-Basic
06 101882 RK	R-7,200	Residential 7,200 sq. ft.	SFR-Basic
06 101883 RK	R-7,200	Residential 7,200 sq. ft.	SFR-Basic
06 101884 RK	R-7,200	Residential 7,200 sq. ft.	SFR-Basic



Accessory Dwelling Units

Index # - File Name: 1.0022 - Single Family Dwellings Data\_Snohomish County.pdf

06 101885 RK	R-7,200	Residential 7,200 sq. ft.	SFR-Basic
06 101886 RK	R-7,200	Residential 7,200 sq. ft.	SFR-Basic
06 100999 RK	R-7,200	Residential 7,200 sq. ft.	SFR-Basic
06 101000 RK	R-7,200	Residential 7,200 sq. ft.	SFR-Basic
06 101001 RK	R-7,200	Residential 7,200 sq. ft.	SFR-Basic
06 101002 RK	R-7,200	Residential 7,200 sq. ft.	SFR-Basic
06 101003 RK	R-7,200	Residential 7,200 sq. ft.	SFR-Basic
06 102616 RK	R-7,200	Residential 7,200 sq. ft.	SFR-Basic
06 101817 RK	R-7,200	Residential 7,200 sq. ft.	SFR-Basic
06 102415 RK	R-7,200	Residential 7,200 sq. ft.	SFR-Basic
06 102617 RK	R-7,200	Residential 7,200 sq. ft.	SFR-Basic
06 102624 RK	R-7,200	Residential 7,200 sq. ft.	SFR-Basic
06 127215 RK	R-7,200	Residential 7,200 sq. ft.	SFR-Basic
06 102621 RK	R-7,200	Residential 7,200 sq. ft.	SFR-Basic
06 102618 RK	R-7,200	Residential 7,200 sq. ft.	SFR-Basic
06 102611 RK	R-7,200	Residential 7,200 sq. ft.	SFR-Basic
06 101819 RK	R-7,200	Residential 7,200 sq. ft.	SFR-Basic
06 102622 RK	R-7,200	Residential 7,200 sq. ft.	SFR-Basic
06 102619 RK	R-7,200	Residential 7,200 sq. ft.	SFR-Basic
06 102613 RK	R-7,200	Residential 7,200 sq. ft.	SFR-Basic
06 102614 RK	R-7,200	Residential 7,200 sq. ft.	SFR-Basic
06 102623 RK	R-7,200	Residential 7,200 sq. ft.	SFR-Basic
06 102620 RK	R-7,200	Residential 7,200 sq. ft.	SFR-Basic
06 102615 RK	R-7,200	Residential 7,200 sq. ft.	SFR-Basic
06 102612 RK	R-7,200	Residential 7,200 sq. ft.	SFR-Basic
06 101448 RK	R-5	Rural-5 Acre	Single Family Res-Combo
06 134821 RK	MR	Multiple Residential	SFR-Basic
06 135975 RK	R-5 : R-7,200	Residential 7,200 sq. ft. : Ru	SFR-Basic
06 132150 RK	R-5 : R-7,200	Residential 7,200 sq. ft. : Ru	SFR-Basic
06 135534 RK	R-5 : R-7,200	Residential 7,200 sq. ft. : Ru	SFR-Basic
06 102279 RK	R-5 : R-7,200	Residential 7,200 sq. ft. : Ru	SFR-Basic
06 100989 RK	R-5 : R-7,200	Residential 7,200 sq. ft. : Ru	SFR-Basic
06 101604 RK	R-5 : R-7,200	Residential 7,200 sq. ft. : Ru	SFR-Basic
06 102176 RK	R-5	Rural-5 Acre	Single Family Res-Combo
06 133246 RK	F	Forestry	Single Family Res-Combo
06 125589 RK	R-5	Rural-5 Acre	SFR-Basic
06 103414 RK	CITY	City	SFR-Basic
06 125135 RK	CITY	City	SFR-Basic
06 127139 RK	CITY	City	SFR-Basic
06 104143 RK	CITY	City	SFR-Basic
06 103415 RK	CITY	City	SFR-Basic
06 126207 RK	CITY	City	SFR-Basic
06 127133 RK	CITY	City	SFR-Basic
06 125886 RK	CITY	City	SFR-Basic
06 125876 RK	CITY	City	SFR-Basic
06 126566 RK	CITY	City	SFR-Basic
06 126212 RK	CITY	City	SFR-Basic

Accessory Dwelling Units

Index # - File Name: 1.0022 - Single Family Dwellings Data\_Snohomish County.pdf

06 126211 RK	CITY	City	SFR-Basic
06 125877 RK	CITY	City	SFR-Basic
06 126208 RK	CITY	City	SFR-Basic
06 104137 RK	CITY	City	SFR-Basic
06 125680 RK	CITY	City	SFR-Basic
06 125883 RK	CITY	City	SFR-Basic
06 125343 RK	CITY	City	SFR-Basic
06 103784 RK	CITY	City	SFR-Basic
06 104124 RK	CITY	City	SFR-Basic
06 104158 RK	CITY	City	SFR-Basic
06 125345 RK	CITY	City	SFR-Basic
06 103782 RK	CITY	City	SFR-Basic
06 104125 RK	CITY	City	SFR-Basic
06 103416 RK	CITY	City	SFR-Basic
06 125881 RK	CITY	City	SFR-Basic
06 125136 RK	CITY	City	SFR-Basic
06 104141 RK	CITY	City	SFR-Basic
06 126209 RK	CITY	City	SFR-Basic
06 127776 RK	CITY	City	SFR-Basic
06 128049 RK	CITY	City	SFR-Basic
06 126210 RK	CITY	City	SFR-Basic
06 128050 RK	CITY	City	SFR-Basic
06 126860 RK	CITY	City	SFR-Basic
06 129510 RK	CITY	City	SFR-Basic
06 127781 RK	CITY	City	SFR-Basic
06 126858 RK	CITY	City	SFR-Basic
06 125214 RK	R-5	Rural-5 Acre	Single Family Res-Combo
06 129821 RK	CITY	City	SFR-Basic
06 129512 RK	CITY	City	SFR-Basic
06 129513 RK	CITY	City	SFR-Basic
06 128447 RK	CITY	City	SFR-Basic
06 127134 RK	CITY	City	SFR-Basic
06 130093 RK	CITY	City	SFR-Basic
06 128051 RK	CITY	City	SFR-Basic
06 128452 RK	CITY	City	SFR-Basic
06 132042 RK	R-7,200	Residential 7,200 sq. ft.	SFR-Basic
06 131878 RK	R-7,200	Residential 7,200 sq. ft.	SFR-Basic
06 128330 RK	R-7,200	Residential 7,200 sq. ft.	SFR-Basic
05 129168 RK	R-5	Rural-5 Acre	Single Family Res-Combo
06 129673 RK	R-7,200	Residential 7,200 sq. ft.	SFR-Basic
06 129745 RK	R-7,200	Residential 7,200 sq. ft.	SFR-Basic
06 129746 RK	R-7,200	Residential 7,200 sq. ft.	SFR-Basic
06 129751 RK	R-7,200	Residential 7,200 sq. ft.	SFR-Basic
06 129752 RK	R-7,200	Residential 7,200 sq. ft.	SFR-Basic
06 129753 RK	R-7,200	Residential 7,200 sq. ft.	SFR-Basic
06 128419 RK	R-7,200	Residential 7,200 sq. ft.	SFR-Basic
06 129754 RK	R-7,200	Residential 7,200 sq. ft.	SFR-Basic

Accessory Dwelling Units

Index # - File Name: 1.0022 - Single Family Dwellings Data\_Snohomish County.pdf

06 129755 RK	R-7,200	Residential 7,200 sq. ft.	SFR-Basic
06 129750 RK	R-7,200	Residential 7,200 sq. ft.	SFR-Basic
06 129253 RK	R-7,200	Residential 7,200 sq. ft.	SFR-Basic
06 128716 RK	R-7,200	Residential 7,200 sq. ft.	SFR-Basic
06 127778 RK	CITY	City	SFR-Basic
06 127349 RK	CITY	City	SFR-Basic
06 129521 RK	CITY	City	SFR-Basic
06 128451 RK	CITY	City	SFR-Basic
06 129511 RK	CITY	City	SFR-Basic
06 130097 RK	CITY	City	SFR-Basic
06 103747 RK	R-7,200	Residential 7,200 sq. ft.	Single Family Res-Combo
06 103746 RK	R-7,200	Residential 7,200 sq. ft.	Single Family Res-Combo
06 126198 RK	R-5	Rural-5 Acre	SFR-Basic
05 128940 RK	R-5	Rural-5 Acre	Single Family Res-Combo
06 102520 RK	F	Forestry	Single Family Res-Combo
06 100188 RK	R-5	Rural-5 Acre	SFR-Basic
06 128689 RK	R-7,200	Residential 7,200 sq. ft.	SFR-Basic
06 128698 RK	R-7,200	Residential 7,200 sq. ft.	SFR-Basic
06 126957 RK	R-7,200	Residential 7,200 sq. ft.	Single Family Res-Combo
06 132039 RK	R-7,200	Residential 7,200 sq. ft.	SFR-Basic
06 126956 RK	R-7,200	Residential 7,200 sq. ft.	SFR-Basic
06 125572 RK	R-7,200	Residential 7,200 sq. ft.	SFR-Basic
06 127767 RK	R-7,200	Residential 7,200 sq. ft.	SFR-Basic
06 126465 RK	R-7,200	Residential 7,200 sq. ft.	SFR-Basic
06 126480 RK	R-7,200	Residential 7,200 sq. ft.	SFR-Basic
06 127768 RK	R-7,200	Residential 7,200 sq. ft.	SFR-Basic
06 126482 RK	R-7,200	Residential 7,200 sq. ft.	SFR-Basic
06 132036 RK	R-7,200	Residential 7,200 sq. ft.	SFR-Basic
06 125579 RK	R-7,200	Residential 7,200 sq. ft.	SFR-Basic
06 126468 RK	R-7,200	Residential 7,200 sq. ft.	SFR-Basic
06 134378 RK	R-7,200	Residential 7,200 sq. ft.	Single Family Res-Combo
06 126475 RK	R-7,200	Residential 7,200 sq. ft.	SFR-Basic
06 127769 RK	R-7,200	Residential 7,200 sq. ft.	SFR-Basic
06 125571 RK	R-7,200	Residential 7,200 sq. ft.	SFR-Basic
05 128907 RK	R-5	Rural-5 Acre	Single Family Res-Combo
06 103617 RK	R-7,200	Residential 7,200 sq. ft.	SFR-Basic
06 103612 RK	R-7,200	Residential 7,200 sq. ft.	SFR-Basic
06 103608 RK	R-7,200	Residential 7,200 sq. ft.	SFR-Basic
06 126124 RK	R-7,200	Residential 7,200 sq. ft.	SFR-Basic
06 126119 RK	R-7,200	Residential 7,200 sq. ft.	SFR-Basic
06 133463 RK	R-7,200	Residential 7,200 sq. ft.	SFR-Basic
06 126122 RK	R-7,200	Residential 7,200 sq. ft.	SFR-Basic
06 126120 RK	R-7,200	Residential 7,200 sq. ft.	SFR-Basic
06 103613 RK	R-7,200	Residential 7,200 sq. ft.	SFR-Basic
06 103615 RK	R-7,200	Residential 7,200 sq. ft.	SFR-Basic
06 103609 RK	R-7,200	Residential 7,200 sq. ft.	SFR-Basic
06 102143 RK	LDMR	Low Density Multiple Reside	SFR-Basic

Accessory Dwelling Units

Index # - File Name: 1.0022 - Single Family Dwellings Data\_Snohomish County.pdf

06 102144 RK	LDMR	Low Density Multiple Reside SFR-Basic	
06 102145 RK	LDMR	Low Density Multiple Reside SFR-Basic	
06 102146 RK	LDMR	Low Density Multiple Reside SFR-Basic	
06 100056 RK	LDMR	Low Density Multiple Reside SFR-Basic	
06 101602 RK	LDMR	Low Density Multiple Reside SFR-Basic	
06 100058 RK	LDMR	Low Density Multiple Reside SFR-Basic	
06 101601 RK	LDMR	Low Density Multiple Reside SFR-Basic	
06 100059 RK	LDMR	Low Density Multiple Reside SFR-Basic	
06 101603 RK	LDMR	Low Density Multiple Reside SFR-Basic	
06 100061 RK	LDMR	Low Density Multiple Reside SFR-Basic	
06 102147 RK	LDMR	Low Density Multiple Reside SFR-Basic	
06 102148 RK	LDMR	Low Density Multiple Reside SFR-Basic	
06 102149 RK	LDMR	Low Density Multiple Reside SFR-Basic	
06 131229 RK	R-5	Rural-5 Acre	SFR-Basic
06 131231 RK	R-5	Rural-5 Acre	SFR-Basic
06 132085 RK	R-5	Rural-5 Acre	SFR-Basic
06 101610 RK	R-5	Rural-5 Acre	SFR-Basic
06 125521 RK	R-5	Rural-5 Acre	SFR-Basic
06 101632 RK	R-5	Rural-5 Acre	SFR-Basic
06 126641 RK	R-5	Rural-5 Acre	SFR-Basic
06 125522 RK	R-5	Rural-5 Acre	SFR-Basic
06 101696 RK	R-5	Rural-5 Acre	SFR-Basic
06 101698 RK	R-5	Rural-5 Acre	SFR-Basic
06 101701 RK	R-5	Rural-5 Acre	SFR-Basic
06 101700 RK	R-5	Rural-5 Acre	SFR-Basic
06 101233 RK	R-5	Rural-5 Acre	SFR-Basic
06 101699 RK	R-5	Rural-5 Acre	SFR-Basic
06 100880 RK	R-5	Rural-5 Acre	SFR-Basic
06 101040 RK	R-5	Rural-5 Acre	SFR-Basic
06 101702 RK	R-5	Rural-5 Acre	SFR-Basic
06 101234 RK	R-5	Rural-5 Acre	SFR-Basic
06 125523 RK	R-5	Rural-5 Acre	SFR-Basic
06 125773 RK	R-5	Rural-5 Acre	SFR-Basic
06 125672 RK	R-5	Rural-5 Acre	SFR-Basic
06 101041 RK	R-5	Rural-5 Acre	SFR-Basic
06 101236 RK	R-5	Rural-5 Acre	SFR-Basic
06 125666 RK	R-5	Rural-5 Acre	SFR-Basic
06 101235 RK	R-5	Rural-5 Acre	SFR-Basic
06 125775 RK	R-5	Rural-5 Acre	SFR-Basic
06 126190 RK	R-5	Rural-5 Acre	SFR-Basic
06 130430 RK	R-5	Rural-5 Acre	SFR-Basic
06 104017 RK	R-5	Rural-5 Acre	SFR-Basic
06 101851 RK	R-5	Rural-5 Acre	SFR-Basic
06 102244 RK	R-5	Rural-5 Acre	SFR-Basic
06 104178 RK	R-5	Rural-5 Acre	Single Family Res-Combo
06 104242 RK	R-5	Rural-5 Acre	SFR-Basic
06 131432 RK	R-5	Rural-5 Acre	SFR-Basic

Accessory Dwelling Units

Index # - File Name: 1.0022 - Single Family Dwellings Data\_Snohomish County.pdf

06 131607 RK	R-5	Rural-5 Acre	SFR-Basic
06 131608 RK	R-5	Rural-5 Acre	SFR-Basic
06 131232 RK	R-5	Rural-5 Acre	SFR-Basic
06 100874 RK	R-5	Rural-5 Acre	SFR-Basic
06 125192 RK	R-5	Rural-5 Acre	SFR-Basic
06 133145 RK	R-5	Rural-5 Acre	SFR-Basic
06 129932 RK	R-5	Rural-5 Acre	Single Family Res-Combo
05 128949 RK	R-5	Rural-5 Acre	Single Family Res-Combo
06 102159 RK	R-5	Rural-5 Acre	SFR-Basic
06 101444 RK	R-5	Rural-5 Acre	SFR-Basic
06 127808 RK	R-5	Rural-5 Acre	SFR-Basic
06 127810 RK	R-5	Rural-5 Acre	SFR-Basic
06 129469 RK	R-5	Rural-5 Acre	SFR-Basic
06 127784 RK	R-5	Rural-5 Acre	Single Family Res-Combo
06 127813 RK	R-5	Rural-5 Acre	SFR-Basic
06 129470 RK	R-5	Rural-5 Acre	SFR-Basic
06 101441 RK	R-5	Rural-5 Acre	SFR-Basic
06 102160 RK	R-5	Rural-5 Acre	SFR-Basic
06 126099 RK	R-5	Rural-5 Acre	SFR-Basic
06 126188 RK	R-5	Rural-5 Acre	SFR-Basic
06 126102 RK	R-5	Rural-5 Acre	SFR-Basic
06 127702 RK	R-5	Rural-5 Acre	SFR-Basic
06 126636 RK	R-5	Rural-5 Acre	SFR-Basic
06 130408 RK	R-5	Rural-5 Acre	SFR-Basic
06 126103 RK	R-5	Rural-5 Acre	SFR-Basic
06 101612 RK	R-5	Rural-5 Acre	SFR-Basic
06 131609 RK	R-5	Rural-5 Acre	SFR-Basic
06 101198 RK	R-5	Rural-5 Acre	SFR-Basic
06 101148 RK	R-5	Rural-5 Acre	Single Family Res-Combo
06 128653 RK	R-5	Rural-5 Acre	Single Family Res-Combo
06 134318 RK	R-7,200	Residential 7,200 sq. ft.	SFR-Basic
06 133687 RK	R-5	Rural-5 Acre	SFR-Basic
06 133683 RK	R-5	Rural-5 Acre	SFR-Basic
06 131340 RK	R-5	Rural-5 Acre	SFR-Basic
06 131341 RK	R-5	Rural-5 Acre	SFR-Basic
06 131345 RK	R-5	Rural-5 Acre	SFR-Basic
06 131343 RK	R-5	Rural-5 Acre	SFR-Basic
06 131342 RK	R-5	Rural-5 Acre	SFR-Basic
06 129466 RK	R-5	Rural-5 Acre	SFR-Basic
06 129467 RK	R-5	Rural-5 Acre	SFR-Basic
06 129468 RK	R-5	Rural-5 Acre	SFR-Basic
06 137126 RK	R-7,200	Residential 7,200 sq. ft.	SFR-Basic
06 137127 RK	R-7,200	Residential 7,200 sq. ft.	SFR-Basic
06 103538 RK	R-7,200	Residential 7,200 sq. ft.	SFR-Basic
06 125495 RK	R-7,200	Residential 7,200 sq. ft.	SFR-Basic
06 101439 RK	R-7,200	Residential 7,200 sq. ft.	SFR-Basic
06 101438 RK	R-7,200	Residential 7,200 sq. ft.	SFR-Basic

Accessory Dwelling Units

Index # - File Name: 1.0022 - Single Family Dwellings Data\_Snohomish County.pdf

06 125499 RK	R-7,200	Residential 7,200 sq. ft.	SFR-Basic
06 102752 RK	R-7,200	Residential 7,200 sq. ft.	Single Family Res-Combo
06 102190 RK	R-7,200	Residential 7,200 sq. ft.	SFR-Basic
06 127792 RK	R-7,200	Residential 7,200 sq. ft.	SFR-Basic
06 128553 RK	R-7,200	Residential 7,200 sq. ft.	SFR-Basic
06 102874 RK	R-7,200	Residential 7,200 sq. ft.	SFR-Basic
06 130672 RK	R-7,200	Residential 7,200 sq. ft.	Single Family Res-Combo
06 127785 RK	R-7,200	Residential 7,200 sq. ft.	SFR-Basic
06 130638 RK	R-7,200	Residential 7,200 sq. ft.	SFR-Basic
06 104190 RK	R-7,200	Residential 7,200 sq. ft.	SFR-Basic
06 130876 RK	R-7,200	Residential 7,200 sq. ft.	SFR-Basic
06 133403 RK	R-7,200	Residential 7,200 sq. ft.	SFR-Basic
06 100403 RK	R-8,400	Residential 8,400 sq. ft.	Single Family Res-Combo
06 103502 RK	R-7,200	Residential 7,200 sq. ft.	SFR-Basic
06 102547 RK	R-7,200	Residential 7,200 sq. ft.	SFR-Basic
06 101762 RK	R-7,200	Residential 7,200 sq. ft.	SFR-Basic
06 103504 RK	R-7,200	Residential 7,200 sq. ft.	SFR-Basic
06 103020 RK	R-7,200	Residential 7,200 sq. ft.	SFR-Basic
06 101434 RK	R-7,200	Residential 7,200 sq. ft.	SFR-Basic
06 102548 RK	R-7,200	Residential 7,200 sq. ft.	SFR-Basic
06 103023 RK	R-7,200	Residential 7,200 sq. ft.	SFR-Basic
06 125945 RK	R-7,200	Residential 7,200 sq. ft.	SFR-Basic
06 132171 RK	R-7,200	Residential 7,200 sq. ft.	SFR-Basic
06 134322 RK	R-7,200	Residential 7,200 sq. ft.	SFR-Basic
06 134319 RK	R-7,200	Residential 7,200 sq. ft.	SFR-Basic
06 134320 RK	R-7,200	Residential 7,200 sq. ft.	SFR-Basic
06 134180 RK	R-9,600	Residential 9,600 sq. ft.	SFR-Basic
06 133930 RK	R-9,600	Residential 9,600 sq. ft.	SFR-Basic
06 132724 RK	R-9,600	Residential 9,600 sq. ft.	SFR-Basic
06 135994 RK	R-9,600	Residential 9,600 sq. ft.	SFR-Basic
06 131583 RK	R-9,600	Residential 9,600 sq. ft.	SFR-Basic
06 128448 RK	R-9,600	Residential 9,600 sq. ft.	SFR-Basic
06 129509 RK	R-9,600	Residential 9,600 sq. ft.	SFR-Basic
06 136066 RK	R-9,600	Residential 9,600 sq. ft.	SFR-Basic
06 130096 RK	R-9,600	Residential 9,600 sq. ft.	SFR-Basic
06 128450 RK	R-9,600	Residential 9,600 sq. ft.	SFR-Basic
06 133653 RK	R-9,600	Residential 9,600 sq. ft.	SFR-Basic
06 135695 RK	R-9,600	Residential 9,600 sq. ft.	SFR-Basic
06 132426 RK	R-9,600	Residential 9,600 sq. ft.	SFR-Basic
06 132725 RK	R-9,600	Residential 9,600 sq. ft.	SFR-Basic
06 135463 RK	R-9,600	Residential 9,600 sq. ft.	SFR-Basic
06 131582 RK	R-9,600	Residential 9,600 sq. ft.	SFR-Basic
06 135995 RK	R-9,600	Residential 9,600 sq. ft.	SFR-Basic
06 132050 RK	R-9,600	Residential 9,600 sq. ft.	SFR-Basic
06 134181 RK	R-9,600	Residential 9,600 sq. ft.	SFR-Basic
06 132051 RK	R-9,600	Residential 9,600 sq. ft.	SFR-Basic
06 132049 RK	R-9,600	Residential 9,600 sq. ft.	SFR-Basic

Accessory Dwelling Units

Index # - File Name: 1.0022 - Single Family Dwellings Data\_Snohomish County.pdf

06 128449 RK	R-9,600	Residential 9,600 sq. ft.	SFR-Basic
06 130095 RK	R-9,600	Residential 9,600 sq. ft.	SFR-Basic
06 129523 RK	R-9,600	Residential 9,600 sq. ft.	SFR-Basic
06 132172 RK	R-7,200	Residential 7,200 sq. ft.	SFR-Basic
06 103539 RK	R-7,200	Residential 7,200 sq. ft.	SFR-Basic
06 128624 RK	R-7,200	Residential 7,200 sq. ft.	SFR-Basic
06 125497 RK	R-7,200	Residential 7,200 sq. ft.	SFR-Basic
06 128552 RK	R-7,200	Residential 7,200 sq. ft.	SFR-Basic
06 132174 RK	R-7,200	Residential 7,200 sq. ft.	SFR-Basic
06 128623 RK	R-7,200	Residential 7,200 sq. ft.	SFR-Basic
06 101763 RK	R-7,200	Residential 7,200 sq. ft.	SFR-Basic
06 125912 RK	R-7,200	Residential 7,200 sq. ft.	SFR-Basic
06 127161 RK	R-7,200	Residential 7,200 sq. ft.	SFR-Basic
06 101765 RK	R-7,200	Residential 7,200 sq. ft.	SFR-Basic
06 102950 RK	R-7,200	Residential 7,200 sq. ft.	SFR-Basic
06 103506 RK	R-7,200	Residential 7,200 sq. ft.	SFR-Basic
06 130642 RK	R-7,200	Residential 7,200 sq. ft.	SFR-Basic
06 130640 RK	R-7,200	Residential 7,200 sq. ft.	SFR-Basic
06 127159 RK	R-7,200	Residential 7,200 sq. ft.	SFR-Basic
06 126643 RK	R-7,200	Residential 7,200 sq. ft.	SFR-Basic
06 125458 RK	R-7,200	Residential 7,200 sq. ft.	SFR-Basic
06 131381 RK	R-7,200	Residential 7,200 sq. ft.	SFR-Basic
06 104189 RK	R-7,200	Residential 7,200 sq. ft.	SFR-Basic
06 102974 RK	R-7,200	Residential 7,200 sq. ft.	SFR-Basic
06 125459 RK	R-7,200	Residential 7,200 sq. ft.	SFR-Basic
06 127786 RK	R-7,200	Residential 7,200 sq. ft.	SFR-Basic
06 131382 RK	R-7,200	Residential 7,200 sq. ft.	SFR-Basic
06 127790 RK	R-7,200	Residential 7,200 sq. ft.	Single Family Res-Combo
06 129412 RK	R-7,200	Residential 7,200 sq. ft.	SFR-Basic
06 134214 RK	R-7,200	Residential 7,200 sq. ft.	SFR-Basic
06 127162 RK	R-7,200	Residential 7,200 sq. ft.	SFR-Basic
06 134215 RK	R-7,200	Residential 7,200 sq. ft.	SFR-Basic
06 130644 RK	R-7,200	Residential 7,200 sq. ft.	SFR-Basic
06 126614 RK	R-7,200	Residential 7,200 sq. ft.	SFR-Basic
06 127160 RK	R-7,200	Residential 7,200 sq. ft.	SFR-Basic
06 126615 RK	R-7,200	Residential 7,200 sq. ft.	SFR-Basic
06 102848 RK	CITY	City	SFR-Basic
06 125434 RK	CITY	City	SFR-Basic
06 127188 RK	CITY	City	SFR-Basic
06 125433 RK	CITY	City	SFR-Basic
06 127190 RK	CITY	City	SFR-Basic
06 125432 RK	CITY	City	SFR-Basic
06 125435 RK	CITY	City	SFR-Basic
06 125431 RK	CITY	City	SFR-Basic
06 102405 RK	CITY	City	SFR-Basic
06 102406 RK	CITY	City	SFR-Basic
06 103889 RK	CITY	City	SFR-Basic

Accessory Dwelling Units

Index # - File Name: 1.0022 - Single Family Dwellings Data\_Snohomish County.pdf

06 133656 RK	R-5	Rural-5 Acre	Single Family Res-Combo
06 128695 RK	R-5	Rural-5 Acre	Single Family Res-Combo
06 101196 RK	R-5	Rural-5 Acre	Single Family Res-Combo
06 104233 RK	CITY	City	SFR-Basic
06 104235 RK	CITY	City	SFR-Basic
06 102644 RK	CITY	City	SFR-Basic
06 102643 RK	CITY	City	SFR-Basic
06 102849 RK	CITY	City	SFR-Basic
06 102850 RK	CITY	City	SFR-Basic
06 127163 RK	R-7,200	Residential 7,200 sq. ft.	SFR-Basic
06 125913 RK	R-7,200	Residential 7,200 sq. ft.	SFR-Basic
06 130637 RK	R-7,200	Residential 7,200 sq. ft.	SFR-Basic
06 129411 RK	R-7,200	Residential 7,200 sq. ft.	SFR-Basic
06 102441 RK	R-5	Rural-5 Acre	SFR-Basic
06 102446 RK	R-5	Rural-5 Acre	SFR-Basic
06 102444 RK	R-5	Rural-5 Acre	SFR-Basic
06 102505 RK	R-5	Rural-5 Acre	SFR-Basic
06 102449 RK	R-5	Rural-5 Acre	SFR-Basic
06 102443 RK	R-5	Rural-5 Acre	SFR-Basic
06 102460 RK	R-5	Rural-5 Acre	SFR-Basic
06 127191 RK	CITY	City	SFR-Basic
06 102451 RK	R-5	Rural-5 Acre	SFR-Basic
06 102452 RK	R-5	Rural-5 Acre	SFR-Basic
06 102454 RK	R-5	Rural-5 Acre	SFR-Basic
06 129186 RK	R-7,200	Residential 7,200 sq. ft.	SFR-Basic
06 125108 RK	R-7,200	Residential 7,200 sq. ft.	SFR-Basic
06 125863 RK	R-7,200	Residential 7,200 sq. ft.	SFR-Basic
06 126862 RK	R-7,200	Residential 7,200 sq. ft.	SFR-Basic
06 126863 RK	R-7,200	Residential 7,200 sq. ft.	SFR-Basic
06 126864 RK	R-7,200	Residential 7,200 sq. ft.	SFR-Basic
06 127077 RK	R-7,200	Residential 7,200 sq. ft.	SFR-Basic
06 127260 RK	R-7,200	Residential 7,200 sq. ft.	SFR-Basic
06 127921 RK	R-7,200	Residential 7,200 sq. ft.	SFR-Basic
06 127922 RK	R-7,200	Residential 7,200 sq. ft.	SFR-Basic
06 127923 RK	R-7,200	Residential 7,200 sq. ft.	SFR-Basic
06 127924 RK	R-7,200	Residential 7,200 sq. ft.	SFR-Basic
06 127925 RK	R-7,200	Residential 7,200 sq. ft.	SFR-Basic
06 129919 RK	R-7,200	Residential 7,200 sq. ft.	SFR-Basic
06 129914 RK	R-7,200	Residential 7,200 sq. ft.	SFR-Basic
06 129915 RK	R-7,200	Residential 7,200 sq. ft.	SFR-Basic
06 126293 RK	CITY	City	SFR-Basic
06 102852 RK	CITY	City	SFR-Basic
06 103890 RK	CITY	City	SFR-Basic
06 127193 RK	CITY	City	SFR-Basic
06 130400 RK	CITY	City	SFR-Basic
06 132461 RK	R-7,200	Residential 7,200 sq. ft.	SFR-Basic
06 134227 RK	R-7,200	Residential 7,200 sq. ft.	SFR-Basic



Accessory Dwelling Units

Index # - File Name: 1.0022 - Single Family Dwellings Data\_Snohomish County.pdf

06 132462 RK	R-7,200	Residential 7,200 sq. ft.	SFR-Basic
06 129916 RK	R-7,200	Residential 7,200 sq. ft.	SFR-Basic
06 129917 RK	R-7,200	Residential 7,200 sq. ft.	SFR-Basic
06 129918 RK	R-7,200	Residential 7,200 sq. ft.	SFR-Basic
06 127078 RK	R-7,200	Residential 7,200 sq. ft.	SFR-Basic
06 127079 RK	R-7,200	Residential 7,200 sq. ft.	SFR-Basic
06 126857 RK	R-7,200	Residential 7,200 sq. ft.	SFR-Basic
06 125681 RK	R-7,200	Residential 7,200 sq. ft.	SFR-Basic
06 134228 RK	R-7,200	Residential 7,200 sq. ft.	SFR-Basic
06 127268 RK	R-7,200	Residential 7,200 sq. ft.	SFR-Basic
06 127920 RK	R-7,200	Residential 7,200 sq. ft.	SFR-Basic
06 129907 RK	R-7,200	Residential 7,200 sq. ft.	SFR-Basic
06 135158 RK	CITY	City	SFR-Basic
06 127340 RK	CITY	City	SFR-Basic
06 126396 RK	CITY	City	SFR-Basic
06 126055 RK	CITY	City	SFR-Basic
06 126187 RK	CITY	City	Single Family Res-Combo
06 126057 RK	CITY	City	SFR-Basic
06 126053 RK	CITY	City	SFR-Basic
06 126397 RK	CITY	City	SFR-Basic
06 126544 RK	CITY	City	SFR-Basic
06 126551 RK	CITY	City	SFR-Basic
06 126545 RK	CITY	City	SFR-Basic
06 126552 RK	CITY	City	SFR-Basic
06 126398 RK	CITY	City	SFR-Basic
06 126054 RK	CITY	City	SFR-Basic
06 130292 RK	CITY	City	SFR-Basic
06 128691 RK	CITY	City	SFR-Basic
06 127341 RK	CITY	City	SFR-Basic
06 128692 RK	CITY	City	SFR-Basic
06 133938 RK	CITY	City	SFR-Basic
06 127342 RK	CITY	City	SFR-Basic
06 126056 RK	CITY	City	SFR-Basic
06 126553 RK	CITY	City	SFR-Basic
06 126546 RK	CITY	City	SFR-Basic
06 130293 RK	CITY	City	Single Family Res-Combo
06 126547 RK	CITY	City	SFR-Basic
06 126549 RK	CITY	City	SFR-Basic
06 128690 RK	CITY	City	SFR-Basic
06 126548 RK	CITY	City	SFR-Basic
06 132178 RK	CITY	City	SFR-Basic
06 135165 RK	CITY	City	SFR-Basic
06 102971 RK	R-5	Rural-5 Acre	Single Family Res-Combo
06 135164 RK	CITY	City	SFR-Basic
06 127339 RK	CITY	City	SFR-Basic
06 126395 RK	CITY	City	SFR-Basic
06 133645 RK	CITY	City	Single Family Res-Combo

Accessory Dwelling Units

Index # - File Name: 1.0022 - Single Family Dwellings Data\_Snohomish County.pdf

06 126543 RK	CITY	City	SFR-Basic
06 126550 RK	CITY	City	SFR-Basic
06 101356 RK	R-5	Rural-5 Acre	Single Family Res-Combo
06 131039 RK	R-7,200	Residential 7,200 sq. ft.	SFR-Basic
06 131040 RK	R-7,200	Residential 7,200 sq. ft.	SFR-Basic
06 126296 RK	R-7,200	Residential 7,200 sq. ft.	SFR-Basic
06 125934 RK	R-7,200	Residential 7,200 sq. ft.	SFR-Basic
06 125935 RK	R-7,200	Residential 7,200 sq. ft.	SFR-Basic
06 127850 RK	R-7,200	Residential 7,200 sq. ft.	SFR-Basic
06 127851 RK	R-7,200	Residential 7,200 sq. ft.	SFR-Basic
06 131042 RK	R-7,200	Residential 7,200 sq. ft.	SFR-Basic
06 131043 RK	R-7,200	Residential 7,200 sq. ft.	SFR-Basic
06 131857 RK	R-7,200	Residential 7,200 sq. ft.	SFR-Basic
06 131290 RK	R-7,200	Residential 7,200 sq. ft.	SFR-Basic
06 131291 RK	R-7,200	Residential 7,200 sq. ft.	SFR-Basic
06 127853 RK	R-7,200	Residential 7,200 sq. ft.	SFR-Basic
06 126624 RK	R-7,200	Residential 7,200 sq. ft.	SFR-Basic
06 128526 RK	R-7,200	Residential 7,200 sq. ft.	SFR-Basic
06 126625 RK	R-7,200	Residential 7,200 sq. ft.	SFR-Basic
06 127848 RK	R-7,200	Residential 7,200 sq. ft.	SFR-Basic
06 126626 RK	R-7,200	Residential 7,200 sq. ft.	SFR-Basic
06 127849 RK	R-7,200	Residential 7,200 sq. ft.	SFR-Basic
06 126627 RK	R-7,200	Residential 7,200 sq. ft.	SFR-Basic
06 127877 RK	R-5	Rural-5 Acre	SFR-Basic
06 102488 RK	R-5	Rural-5 Acre	SFR-Basic
06 102489 RK	R-5	Rural-5 Acre	SFR-Basic
06 102490 RK	R-5	Rural-5 Acre	SFR-Basic
06 102781 RK	R-5	Rural-5 Acre	SFR-Basic
06 102782 RK	R-5	Rural-5 Acre	SFR-Basic
06 102784 RK	R-5	Rural-5 Acre	SFR-Basic
06 102785 RK	R-5	Rural-5 Acre	SFR-Basic
06 102786 RK	R-5	Rural-5 Acre	SFR-Basic
06 102787 RK	R-5	Rural-5 Acre	SFR-Basic
06 135091 RK	R-5	Rural-5 Acre	SFR-Basic
06 104089 RK	R-5	Rural-5 Acre	SFR-Basic
06 131866 RK	R-5	Rural-5 Acre	SFR-Basic
06 131867 RK	R-5	Rural-5 Acre	SFR-Basic
06 125512 RK	R-5	Rural-5 Acre	SFR-Basic
06 102642 RK	R-7,200	Residential 7,200 sq. ft.	SFR-Basic
06 127027 RK	R-7,200	Residential 7,200 sq. ft.	Single Family Res-Combo
06 100634 RK	R-7,200	Residential 7,200 sq. ft.	SFR-Basic
06 101294 RK	R-7,200	Residential 7,200 sq. ft.	SFR-Basic
06 100968 RK	R-7,200	Residential 7,200 sq. ft.	SFR-Basic
06 103478 RK	R-7,200	Residential 7,200 sq. ft.	SFR-Basic
06 102640 RK	R-7,200	Residential 7,200 sq. ft.	SFR-Basic
05 129087 RK	R-7,200	Residential 7,200 sq. ft.	SFR-Basic
06 101771 RK	R-7,200	Residential 7,200 sq. ft.	SFR-Basic

Accessory Dwelling Units

Index # - File Name: 1.0022 - Single Family Dwellings Data\_Snohomish County.pdf

06 103888 RK	R-7,200	Residential 7,200 sq. ft.	SFR-Basic
06 101292 RK	R-7,200	Residential 7,200 sq. ft.	SFR-Basic
06 100091 RK	R-7,200	Residential 7,200 sq. ft.	SFR-Basic
06 127150 RK	RRT-10	Rural Resource Transition-1(Single Family Res-Combo	
06 127152 RK	RRT-10	Rural Resource Transition-1(Single Family Res-Combo	
06 126688 RK	RRT-10	Rural Resource Transition-1(SFR-Basic	
06 126687 RK	RRT-10	Rural Resource Transition-1(SFR-Basic	
06 128128 RK	RRT-10	Rural Resource Transition-1(Single Family Res-Combo	
06 125169 RK	R-5	Rural-5 Acre	Single Family Res-Combo
05 128851 RK	R-7,200	Residential 7,200 sq. ft.	SFR-Basic
06 100089 RK	R-7,200	Residential 7,200 sq. ft.	SFR-Basic
05 128852 RK	R-7,200	Residential 7,200 sq. ft.	SFR-Basic
06 100645 RK	R-7,200	Residential 7,200 sq. ft.	SFR-Basic
06 103150 RK	R-7,200	Residential 7,200 sq. ft.	SFR-Basic
06 100090 RK	R-7,200	Residential 7,200 sq. ft.	SFR-Basic
06 103887 RK	R-7,200	Residential 7,200 sq. ft.	SFR-Basic
06 101772 RK	R-7,200	Residential 7,200 sq. ft.	SFR-Basic
05 128667 RK	R-7,200	Residential 7,200 sq. ft.	SFR-Basic
06 129429 RK	RRT-10	Rural Resource Transition-1(Single Family Res-Combo	
06 126163 RK	RRT-10	Rural Resource Transition-1(Single Family Res-Combo	
06 124937 RK	LDMR	Low Density Multiple Reside	SFR-Basic
06 102504 RK	R-7,200	Residential 7,200 sq. ft.	Single Family Res-Combo
06 126663 RK	R-7,200	Residential 7,200 sq. ft.	Single Family Res-Combo
06 133191 RK	RRT-10	Rural Resource Transition-1(SFR-Basic	
06 130646 RK	RRT-10	Rural Resource Transition-1(SFR-Basic	
06 132169 RK	RRT-10	Rural Resource Transition-1(SFR-Basic	
06 127223 RK	RRT-10	Rural Resource Transition-1(Single Family Res-Combo	
06 128126 RK	RRT-10	Rural Resource Transition-1(Single Family Res-Combo	
06 103813 RK	RRT-10	Rural Resource Transition-1(Single Family Res-Combo	
06 129423 RK	RRT-10	Rural Resource Transition-1(Single Family Res-Combo	
06 130928 RK	RRT-10	Rural Resource Transition-1(Single Family Res-Combo	
06 129150 RK	RRT-10	Rural Resource Transition-1(Single Family Res-Combo	
06 129149 RK	RRT-10	Rural Resource Transition-1(Single Family Res-Combo	
06 127685 RK	RRT-10	Rural Resource Transition-1(Single Family Res-Combo	
06 127679 RK	RRT-10	Rural Resource Transition-1(Single Family Res-Combo	
06 126719 RK	RRT-10	Rural Resource Transition-1(Single Family Res-Combo	
06 101834 RK	R-7,200	Residential 7,200 sq. ft.	Single Family Res-Combo
06 131584 RK	R-5	Rural-5 Acre	Single Family Res-Combo
06 124909 RK	R-7,200	Residential 7,200 sq. ft.	SFR-Basic
06 101012 RK	R-7,200	Residential 7,200 sq. ft.	SFR-Basic
06 102206 RK	R-7,200	Residential 7,200 sq. ft.	Single Family Res-Combo
06 125268 RK	R-7,200	Residential 7,200 sq. ft.	SFR-Basic
06 133162 RK	R-7,200	Residential 7,200 sq. ft.	Single Family Res-Combo
05 129298 RK	R-7,200	Residential 7,200 sq. ft.	Single Family Res-Combo
05 129290 RK	R-7,200	Residential 7,200 sq. ft.	Single Family Res-Combo
05 129293 RK	R-7,200	Residential 7,200 sq. ft.	Single Family Res-Combo
05 128300 RK	LDMR	Low Density Multiple Reside	SFR-Basic

Accessory Dwelling Units

Index # - File Name: 1.0022 - Single Family Dwellings Data\_Snohomish County.pdf

05 128962 RK	LDMR	Low Density Multiple Reside	SFR-Basic
05 128964 RK	LDMR	Low Density Multiple Reside	SFR-Basic
05 128966 RK	LDMR	Low Density Multiple Reside	SFR-Basic
06 102228 RK	LDMR	Low Density Multiple Reside	SFR-Basic
06 103114 RK	LDMR	Low Density Multiple Reside	SFR-Basic
06 103118 RK	LDMR	Low Density Multiple Reside	SFR-Basic
06 103115 RK	LDMR	Low Density Multiple Reside	SFR-Basic
06 103119 RK	LDMR	Low Density Multiple Reside	SFR-Basic
05 128663 RK	R-7,200	Residential 7,200 sq. ft.	SFR-Basic
06 135016 RK	R-7,200	Residential 7,200 sq. ft.	Single Family Res-Combo
06 102205 RK	R-7,200	Residential 7,200 sq. ft.	Single Family Res-Combo
06 127432 RK	R-7,200	Residential 7,200 sq. ft.	Single Family Res-Combo
06 126822 RK	R-7,200	Residential 7,200 sq. ft.	Single Family Res-Combo
05 127878 RK	R-7,200	Residential 7,200 sq. ft.	Single Family Res-Combo
06 130872 RK	R-7,200	Residential 7,200 sq. ft.	Single Family Res-Combo
06 125426 RK	R-7,200	Residential 7,200 sq. ft.	Single Family Res-Combo
06 102507 RK	R-7,200	Residential 7,200 sq. ft.	Single Family Res-Combo
05 128662 RK	R-7,200	Residential 7,200 sq. ft.	SFR-Basic
05 128855 RK	R-7,200	Residential 7,200 sq. ft.	SFR-Basic
05 128825 RK	R-7,200	Residential 7,200 sq. ft.	Single Family Res-Combo
05 128661 RK	R-7,200	Residential 7,200 sq. ft.	SFR-Basic
06 127042 RK	R-7,200	Residential 7,200 sq. ft.	Single Family Res-Combo
05 128178 RK	R-7,200	Residential 7,200 sq. ft.	SFR-Basic
05 126337 RK	R-7,200	Residential 7,200 sq. ft.	SFR-Basic
06 101620 RK	R-7,200	Residential 7,200 sq. ft.	SFR-Basic
06 100086 RK	R-7,200	Residential 7,200 sq. ft.	SFR-Basic
06 100970 RK	R-7,200	Residential 7,200 sq. ft.	SFR-Basic
06 132501 RK	MR	Multiple Residential	SFR-Basic
05 126619 RK	MR	Multiple Residential	Single Family Res-Combo
06 125049 RK	R-7,200	Residential 7,200 sq. ft.	SFR-Basic
06 125052 RK	R-7,200	Residential 7,200 sq. ft.	SFR-Basic
06 125050 RK	R-7,200	Residential 7,200 sq. ft.	SFR-Basic
06 100973 RK	R-7,200	Residential 7,200 sq. ft.	SFR-Basic
06 100972 RK	R-7,200	Residential 7,200 sq. ft.	SFR-Basic
06 100971 RK	R-7,200	Residential 7,200 sq. ft.	SFR-Basic
06 100085 RK	R-7,200	Residential 7,200 sq. ft.	SFR-Basic
06 100087 RK	R-7,200	Residential 7,200 sq. ft.	SFR-Basic
06 100084 RK	R-7,200	Residential 7,200 sq. ft.	SFR-Basic
06 133835 RK	MR	Multiple Residential	SFR-Basic
06 129844 RK	MR	Multiple Residential	SFR-Basic
06 129845 RK	MR	Multiple Residential	SFR-Basic
06 125904 RK	MR	Multiple Residential	SFR-Basic
06 125903 RK	MR	Multiple Residential	SFR-Basic
06 125902 RK	MR	Multiple Residential	SFR-Basic
06 125901 RK	MR	Multiple Residential	SFR-Basic
06 125906 RK	MR	Multiple Residential	SFR-Basic
06 125907 RK	MR	Multiple Residential	SFR-Basic

Accessory Dwelling Units

Index # - File Name: 1.0022 - Single Family Dwellings Data\_Snohomish County.pdf

06 125910 RK	MR	Multiple Residential	SFR-Basic
06 125911 RK	MR	Multiple Residential	SFR-Basic
06 103983 RK	MR	Multiple Residential	SFR-Basic
06 103986 RK	MR	Multiple Residential	SFR-Basic
06 103987 RK	MR	Multiple Residential	SFR-Basic
06 103433 RK	MR	Multiple Residential	SFR-Basic
06 103435 RK	MR	Multiple Residential	SFR-Basic
06 103434 RK	MR	Multiple Residential	SFR-Basic
06 103436 RK	MR	Multiple Residential	SFR-Basic
06 102342 RK	MR	Multiple Residential	SFR-Basic
06 102345 RK	MR	Multiple Residential	SFR-Basic
06 102341 RK	MR	Multiple Residential	SFR-Basic
06 102347 RK	MR	Multiple Residential	SFR-Basic
06 102346 RK	MR	Multiple Residential	SFR-Basic
06 102338 RK	MR	Multiple Residential	SFR-Basic
05 126443 RK	MR	Multiple Residential	SFR-Basic
05 126446 RK	MR	Multiple Residential	SFR-Basic
05 126445 RK	MR	Multiple Residential	SFR-Basic
05 126444 RK	MR	Multiple Residential	SFR-Basic
05 124143 RK	RRT-10	Rural Resource Transition-10	SFR-Basic
05 127858 RK	R-5	Rural-5 Acre	Single Family Res-Combo
06 127749 RK	MR	Multiple Residential	SFR-Basic
06 132504 RK	MR	Multiple Residential	SFR-Basic
06 129882 RK	MR	Multiple Residential	SFR-Basic
06 127751 RK	MR	Multiple Residential	SFR-Basic
06 133644 RK	MR	Multiple Residential	SFR-Basic
06 125334 RK	LDMR : MR	Low Density Multiple Reside	SFR-Basic
06 133909 RK	LDMR	Low Density Multiple Reside	SFR-Basic
06 125332 RK	LDMR	Low Density Multiple Reside	SFR-Basic
06 103139 RK	LDMR	Low Density Multiple Reside	SFR-Basic
06 104218 RK	LDMR	Low Density Multiple Reside	SFR-Basic
06 102271 RK	LDMR	Low Density Multiple Reside	SFR-Basic
06 104219 RK	LDMR	Low Density Multiple Reside	SFR-Basic
06 102273 RK	LDMR	Low Density Multiple Reside	SFR-Basic
06 103140 RK	LDMR	Low Density Multiple Reside	SFR-Basic
06 101846 RK	LDMR	Low Density Multiple Reside	SFR-Basic
06 102689 RK	LDMR : MR	Low Density Multiple Reside	SFR-Basic
06 101845 RK	MR	Multiple Residential	SFR-Basic
06 102693 RK	MR	Multiple Residential	SFR-Basic
06 101844 RK	MR	Multiple Residential	SFR-Basic
05 124830 RK	RRT-10	Rural Resource Transition-10	SFR-Basic
05 124833 RK	RRT-10	Rural Resource Transition-10	SFR-Basic
06 103929 RK	R-5	Rural-5 Acre	Single Family Res-Combo
06 129482 RK			SFR-Basic
06 126594 RK	MR	Multiple Residential	SFR-Basic
06 126595 RK	MR	Multiple Residential	SFR-Basic
06 126596 RK	MR	Multiple Residential	SFR-Basic

Accessory Dwelling Units

Index # - File Name: 1.0022 - Single Family Dwellings Data\_Snohomish County.pdf

06 126598 RK	MR	Multiple Residential	SFR-Basic
06 126599 RK	MR	Multiple Residential	SFR-Basic
06 126838 RK	MR	Multiple Residential	SFR-Basic
06 126842 RK	MR	Multiple Residential	SFR-Basic
06 126850 RK	MR	Multiple Residential	SFR-Basic
06 126853 RK	MR	Multiple Residential	SFR-Basic
06 126855 RK	MR	Multiple Residential	SFR-Basic
06 126866 RK	MR	Multiple Residential	SFR-Basic
06 128268 RK	MR	Multiple Residential	SFR-Basic
06 128269 RK	MR	Multiple Residential	SFR-Basic
06 128271 RK	MR	Multiple Residential	SFR-Basic
06 128267 RK	MR	Multiple Residential	SFR-Basic
06 129833 RK	MR	Multiple Residential	SFR-Basic
06 129837 RK	MR	Multiple Residential	SFR-Basic
06 129838 RK	MR	Multiple Residential	SFR-Basic
06 129840 RK	MR	Multiple Residential	SFR-Basic
06 129841 RK	MR	Multiple Residential	SFR-Basic
06 127235 RK	R-5	Rural-5 Acre	Single Family Res-Combo
06 102492 RK	R-5	Rural-5 Acre	Single Family Res-Combo
06 134809 RK	R-5	Rural-5 Acre	Single Family Res-Combo
05 123590 RK	A-10	Agriculture-10 Acre	Single Family Res-Combo
05 123595 RK	R-5	Rural-5 Acre	Single Family Res-Combo
06 129420 RK	F	Forestry	Single Family Res-Combo
05 123639 RK	RRT-10	Rural Resource Transition-10	SFR-Basic
06 130147 RK	R-5	Rural-5 Acre	SFR-Basic
06 131108 RK	R-5	Rural-5 Acre	Single Family Res-Combo
06 102591 RK	LDMR	Low Density Multiple Reside	SFR-Basic
06 102592 RK	LDMR	Low Density Multiple Reside	SFR-Basic
06 102933 RK	LDMR	Low Density Multiple Reside	SFR-Basic
06 101767 RK	LDMR	Low Density Multiple Reside	SFR-Basic
06 102701 RK	LDMR	Low Density Multiple Reside	SFR-Basic
05 123412 001 00 RK	R-5	Rural-5 Acre	Single Family Res-Combo
06 103375 RK	R-5	Rural-5 Acre	Single Family Res-Combo
06 100775 RK	LDMR	Low Density Multiple Reside	SFR-Basic
06 100769 RK	LDMR	Low Density Multiple Reside	SFR-Basic
06 102932 RK	LDMR	Low Density Multiple Reside	SFR-Basic
06 100981 RK	LDMR	Low Density Multiple Reside	SFR-Basic
06 102930 RK	LDMR	Low Density Multiple Reside	SFR-Basic
06 102931 RK	LDMR	Low Density Multiple Reside	SFR-Basic
06 102928 RK	LDMR	Low Density Multiple Reside	SFR-Basic
06 102929 RK	LDMR	Low Density Multiple Reside	SFR-Basic
06 102297 RK	LDMR	Low Density Multiple Reside	SFR-Basic
06 101095 RK	R-7,200	Residential 7,200 sq. ft.	SFR-Basic
06 101956 RK	LDMR	Low Density Multiple Reside	SFR-Basic
06 100782 RK	LDMR	Low Density Multiple Reside	SFR-Basic
06 101958 RK	LDMR	Low Density Multiple Reside	SFR-Basic
06 101960 RK	LDMR	Low Density Multiple Reside	SFR-Basic

Accessory Dwelling Units

Index # - File Name: 1.0022 - Single Family Dwellings Data\_Snohomish County.pdf

06 102590 RK	LDMR	Low Density Multiple Reside	SFR-Basic
06 101092 RK	R-7,200	Residential 7,200 sq. ft.	SFR-Basic
06 130657 RK	R-7,200	Residential 7,200 sq. ft.	SFR-Basic
06 129953 RK	R-7,200	Residential 7,200 sq. ft.	SFR-Basic
05 128740 RK	MR	Multiple Residential	Single Family Res-Combo
06 101049 RK	R-7,200	Residential 7,200 sq. ft.	SFR-Basic
06 102699 RK	R-7,200	Residential 7,200 sq. ft.	SFR-Basic
06 131301 RK	R-7,200	Residential 7,200 sq. ft.	SFR-Basic
06 126772 RK	R-5	Rural-5 Acre	Single Family Res-Combo
06 129654 RK	R-7,200	Residential 7,200 sq. ft.	SFR-Basic
06 130656 RK	R-7,200	Residential 7,200 sq. ft.	SFR-Basic
06 129651 RK	R-7,200	Residential 7,200 sq. ft.	SFR-Basic
06 127043 RK	R-7,200	Residential 7,200 sq. ft.	SFR-Basic
06 126047 RK	R-7,200	Residential 7,200 sq. ft.	SFR-Basic
06 125544 RK	R-7,200	Residential 7,200 sq. ft.	SFR-Basic
06 126058 RK	R-7,200	Residential 7,200 sq. ft.	SFR-Basic
06 103427 RK	R-7,200	Residential 7,200 sq. ft.	SFR-Basic
06 103425 RK	R-7,200	Residential 7,200 sq. ft.	SFR-Basic
06 129259 RK	R-7,200	Residential 7,200 sq. ft.	SFR-Basic
06 131054 RK	R-7,200	Residential 7,200 sq. ft.	SFR-Basic
06 134156 RK	R-7,200	Residential 7,200 sq. ft.	Single Family Res-Combo
06 131793 RK	R-5	Rural-5 Acre	SFR-Basic
05 122806 RK	R-5	Rural-5 Acre	Single Family Res-Combo
06 125570 RK	MR	Multiple Residential	SFR-Basic
06 125054 RK	R-7,200	Residential 7,200 sq. ft.	SFR-Basic
06 125055 RK	R-7,200	Residential 7,200 sq. ft.	SFR-Basic
05 128857 RK	R-7,200	Residential 7,200 sq. ft.	SFR-Basic
05 122707 RK	A-10	Agriculture-10 Acre	Single Family Res-Combo
05 128183 RK	R-7,200	Residential 7,200 sq. ft.	Single Family Res-Combo
06 129143 RK	R-7,200(PRD)	Residential 7,200 sq. ft.	SFR-Basic
06 125051 RK	R-7,200	Residential 7,200 sq. ft.	SFR-Basic
06 125053 RK	R-7,200	Residential 7,200 sq. ft.	SFR-Basic
05 128181 RK	R-7,200	Residential 7,200 sq. ft.	Single Family Res-Combo
06 102015 RK	MR	Multiple Residential	SFR-Basic
06 102557 RK	MR	Multiple Residential	SFR-Basic
06 102608 RK	MR	Multiple Residential	SFR-Basic
06 102627 RK	MR	Multiple Residential	SFR-Basic
06 125338 RK	MR	Multiple Residential	SFR-Basic
06 103573 RK	MR	Multiple Residential	SFR-Basic
06 103574 RK	MR	Multiple Residential	SFR-Basic
06 102559 RK	MR	Multiple Residential	SFR-Basic
06 125578 RK	MR	Multiple Residential	SFR-Basic
06 125340 RK	MR	Multiple Residential	SFR-Basic
06 104062 RK	MR	Multiple Residential	SFR-Basic
06 102081 RK	MR	Multiple Residential	SFR-Basic
06 100062 RK	MR	Multiple Residential	SFR-Basic
06 132490 RK	R-7,200(PRD)	Residential 7,200 sq. ft.	SFR-Basic

Accessory Dwelling Units

Index # - File Name: 1.0022 - Single Family Dwellings Data\_Snohomish County.pdf

06 132427 RK	R-7,200(PRD)	Residential 7,200 sq. ft.	SFR-Basic
06 130087 RK	R-7,200(PRD)	Residential 7,200 sq. ft.	SFR-Basic
06 130088 RK	R-7,200(PRD)	Residential 7,200 sq. ft.	SFR-Basic
06 129141 RK	R-7,200(PRD)	Residential 7,200 sq. ft.	SFR-Basic
06 132418 RK	R-7,200(PRD)	Residential 7,200 sq. ft.	SFR-Basic
06 132492 RK	R-7,200(PRD)	Residential 7,200 sq. ft.	SFR-Basic
06 132497 RK	R-7,200(PRD)	Residential 7,200 sq. ft.	SFR-Basic
05 128917 RK	RRT-10	Rural Resource Transition-1(Single Family Res-Combo	
06 129703 RK	RRT-10	Rural Resource Transition-1(Single Family Res-Combo	
05 122015 RK	R-5	Rural-5 Acre	Single Family Res-Combo
06 130083 RK	R-7,200(PRD)	Residential 7,200 sq. ft.	SFR-Basic
06 130086 RK	R-7,200(PRD)	Residential 7,200 sq. ft.	SFR-Basic
06 103395 RK	R-7,200	Residential 7,200 sq. ft.	SFR-Basic
06 103396 RK	R-7,200	Residential 7,200 sq. ft.	SFR-Basic
06 103397 RK	R-7,200	Residential 7,200 sq. ft.	SFR-Basic
06 103398 RK	R-7,200	Residential 7,200 sq. ft.	SFR-Basic
06 103399 RK	R-7,200	Residential 7,200 sq. ft.	SFR-Basic
06 103400 RK	R-7,200	Residential 7,200 sq. ft.	SFR-Basic
06 103401 RK	R-7,200	Residential 7,200 sq. ft.	SFR-Basic
06 103406 RK	R-7,200	Residential 7,200 sq. ft.	SFR-Basic
06 100031 RK	RRT-10	Rural Resource Transition-1(Single Family Res-Combo	
06 128643 RK	RRT-10	Rural Resource Transition-1(Single Family Res-Combo	
06 102431 RK	RRT-10	Rural Resource Transition-1(SFR-Basic	
06 101759 RK	RRT-10	Rural Resource Transition-1(Single Family Res-Combo	
06 125956 RK	RRT-10	Rural Resource Transition-1(Single Family Res-Combo	
06 103394 RK	R-7,200	Residential 7,200 sq. ft.	SFR-Basic
06 101877 RK	R-7,200	Residential 7,200 sq. ft.	SFR-Basic
06 101876 RK	R-7,200	Residential 7,200 sq. ft.	SFR-Basic
06 101881 RK	R-7,200	Residential 7,200 sq. ft.	SFR-Basic
06 101880 RK	R-7,200	Residential 7,200 sq. ft.	SFR-Basic
06 101879 RK	R-7,200	Residential 7,200 sq. ft.	SFR-Basic
06 101878 RK	R-7,200	Residential 7,200 sq. ft.	SFR-Basic
06 100183 RK	R-7,200	Residential 7,200 sq. ft.	SFR-Basic
06 100184 RK	R-7,200	Residential 7,200 sq. ft.	SFR-Basic
06 100191 RK	R-7,200	Residential 7,200 sq. ft.	SFR-Basic
06 124942 RK	R-7,200	Residential 7,200 sq. ft.	SFR-Basic
06 100186 RK	R-7,200	Residential 7,200 sq. ft.	SFR-Basic
06 100187 RK	R-7,200	Residential 7,200 sq. ft.	SFR-Basic
06 100192 RK	R-7,200	Residential 7,200 sq. ft.	SFR-Basic
06 100092 RK	RRT-10	Rural Resource Transition-1(Single Family Res-Combo	
06 102418 RK	RRT-10	Rural Resource Transition-1(SFR-Basic	
06 131954 RK	RRT-10	Rural Resource Transition-1(Single Family Res-Combo	
06 103527 RK	RRT-10	Rural Resource Transition-1(Single Family Res-Combo	
05 128815 RK	RRT-10	Rural Resource Transition-1(Single Family Res-Combo	
06 102430 RK	RRT-10	Rural Resource Transition-1(SFR-Basic	
06 100738 RK	RRT-10	Rural Resource Transition-1(Single Family Res-Combo	
05 128879 RK	RRT-10	Rural Resource Transition-1(Single Family Res-Combo	



Accessory Dwelling Units

Index # - File Name: 1.0022 - Single Family Dwellings Data\_Snohomish County.pdf

06 103830 RK	RRT-10	Rural Resource Transition-1(Single Family Res-Combo	
06 103263 RK	RRT-10	Rural Resource Transition-1(Single Family Res-Combo	
06 125951 RK	RRT-10	Rural Resource Transition-1(Single Family Res-Combo	
05 126537 RK	RRT-10	Rural Resource Transition-1(Single Family Res-Combo	
05 126531 RK	RRT-10	Rural Resource Transition-1(Single Family Res-Combo	
06 127261 RK	RRT-10	Rural Resource Transition-1(Single Family Res-Combo	
05 129111 RK	RRT-10	Rural Resource Transition-1(Single Family Res-Combo	
06 126576 RK	R-5	Rural-5 Acre	Single Family Res-Combo
06 126674 RK	RRT-10	Rural Resource Transition-1(SFR-Basic	
06 130108 RK	RRT-10	Rural Resource Transition-1(SFR-Basic	
06 127265 RK	RRT-10	Rural Resource Transition-1(Single Family Res-Combo	
05 126538 RK	RRT-10	Rural Resource Transition-1(Single Family Res-Combo	
06 134898 RK	RRT-10	Rural Resource Transition-1(Single Family Res-Combo	
05 128352 RK	RRT-10	Rural Resource Transition-1(Single Family Res-Combo	
06 126300 RK	RRT-10	Rural Resource Transition-1(SFR-Basic	
06 100666 RK	UC	Urban Center	SFR-Basic
06 100661 RK	UC	Urban Center	SFR-Basic
06 100669 RK	UC	Urban Center	SFR-Basic
06 100660 RK	UC	Urban Center	SFR-Basic
06 100675 RK	UC	Urban Center	SFR-Basic
06 100664 RK	UC	Urban Center	SFR-Basic
06 100670 RK	UC	Urban Center	SFR-Basic
06 100677 RK	UC	Urban Center	SFR-Basic
06 101346 RK	UC	Urban Center	SFR-Basic
06 101349 RK	UC	Urban Center	SFR-Basic
06 101352 RK	UC	Urban Center	SFR-Basic
06 102824 RK	UC	Urban Center	Single Family Res-Combo
06 100766 RK	UC	Urban Center	SFR-Basic
06 101350 RK	UC	Urban Center	SFR-Basic
06 100768 RK	UC	Urban Center	SFR-Basic
06 101351 RK	UC	Urban Center	SFR-Basic
06 100767 RK	UC	Urban Center	SFR-Basic
06 101347 RK	UC	Urban Center	SFR-Basic
06 101348 RK	UC	Urban Center	SFR-Basic
06 100665 RK	UC	Urban Center	SFR-Basic
06 100672 RK	UC	Urban Center	SFR-Basic
06 100674 RK	UC	Urban Center	SFR-Basic
06 100668 RK	UC	Urban Center	SFR-Basic
06 100659 RK	UC	Urban Center	SFR-Basic
06 100667 RK	UC	Urban Center	SFR-Basic
05 120415 RK	R-5	Rural-5 Acre	Single Family Res-Combo
05 125658 RK	R-9,600	Residential 9,600 sq. ft.	SFR-Basic
06 127424 RK	R-9,600	Residential 9,600 sq. ft.	SFR-Basic
06 102322 RK	R-9,600	Residential 9,600 sq. ft.	Single Family Res-Combo
06 129065 RK	R-9,600	Residential 9,600 sq. ft.	Single Family Res-Combo
06 132986 RK	R-5	Rural-5 Acre	Single Family Res-Combo
06 129052 RK	R-5	Rural-5 Acre	SFR-Basic

Accessory Dwelling Units

Index # - File Name: 1.0022 - Single Family Dwellings Data\_Snohomish County.pdf

06 126974 RK	R-9,600	Residential 9,600 sq. ft.	Single Family Res-Combo
06 101540 RK	R-9,600	Residential 9,600 sq. ft.	SFR-Basic
06 103568 RK	R-9,600	Residential 9,600 sq. ft.	SFR-Basic
06 102583 RK	R-9,600	Residential 9,600 sq. ft.	Single Family Res-Combo
06 125507 RK	R-9,600	Residential 9,600 sq. ft.	SFR-Basic
06 125508 RK	R-9,600	Residential 9,600 sq. ft.	SFR-Basic
06 102005 RK	R-9,600	Residential 9,600 sq. ft.	SFR-Basic
05 128826 RK	R-7,200	Residential 7,200 sq. ft.	Single Family Res-Combo
06 102868 RK	CITY	City	Single Family Res-Combo
05 127995 RK	CITY	City	SFR-Basic
06 101537 RK	R-9,600	Residential 9,600 sq. ft.	SFR-Basic
06 101538 RK	R-9,600	Residential 9,600 sq. ft.	SFR-Basic
06 103567 RK	R-9,600	Residential 9,600 sq. ft.	SFR-Basic
06 102002 RK	R-9,600	Residential 9,600 sq. ft.	SFR-Basic
06 127425 RK	R-9,600	Residential 9,600 sq. ft.	SFR-Basic
06 125143 RK	R-9,600	Residential 9,600 sq. ft.	SFR-Basic
05 126042 RK	R-9,600	Residential 9,600 sq. ft.	SFR-Basic
05 126043 RK	R-9,600	Residential 9,600 sq. ft.	SFR-Basic
05 126044 RK	R-9,600	Residential 9,600 sq. ft.	SFR-Basic
05 126045 RK	R-9,600	Residential 9,600 sq. ft.	SFR-Basic
05 126046 RK	R-9,600	Residential 9,600 sq. ft.	SFR-Basic
05 125160 RK	R-9,600	Residential 9,600 sq. ft.	SFR-Basic
06 126501 RK	R-5	Rural-5 Acre	Single Family Res-Combo
06 102513 RK	R-7,200	Residential 7,200 sq. ft.	SFR-Basic
06 101566 RK	R-7,200	Residential 7,200 sq. ft.	SFR-Basic
06 101565 RK	R-7,200	Residential 7,200 sq. ft.	SFR-Basic
05 127992 RK	CITY	City	SFR-Basic
06 102407 RK	CITY	City	SFR-Basic
06 104094 RK	R-9,600	Residential 9,600 sq. ft.	Single Family Res-Combo
06 133796 RK	R-7,200	Residential 7,200 sq. ft.	SFR-Basic
05 127993 RK	CITY	City	SFR-Basic
05 124388 RK	CITY	City	SFR-Basic
05 128820 RK	R-5	Rural-5 Acre	SFR-Basic
06 104077 RK	R-5	Rural-5 Acre	Single Family Res-Combo
05 127782 RK	CITY	City	Single Family Res-Combo
06 102114 RK	R-5	Rural-5 Acre	Single Family Res-Combo
05 124148 RK	CITY	City	SFR-Basic
06 102408 RK	CITY	City	SFR-Basic
06 127415 RK	CITY	City	SFR-Basic
06 101293 RK	CITY	City	SFR-Basic
06 100635 RK	CITY	City	SFR-Basic
05 128066 RK	CITY	City	SFR-Basic
06 103153 RK	CITY	City	SFR-Basic
06 102817 RK	R-5	Rural-5 Acre	Single Family Res-Combo
06 126295 RK	CITY	City	SFR-Basic
06 100369 RK	R-5	Rural-5 Acre	Single Family Res-Combo
06 125398 RK	CITY	City	SFR-Basic

Accessory Dwelling Units

Index # - File Name: 1.0022 - Single Family Dwellings Data\_Snohomish County.pdf

05 125639 RK	CITY	City	SFR-Basic
05 123233 RK	CITY	City	SFR-Basic
06 125436 RK	CITY	City	SFR-Basic
06 125437 RK	CITY	City	SFR-Basic
06 125438 RK	CITY	City	SFR-Basic
05 126071 RK	R-5	Rural-5 Acre	Single Family Res-Combo
06 129879 RK	R-5	Rural-5 Acre	Single Family Res-Combo
05 126073 RK	R-5	Rural-5 Acre	Single Family Res-Combo
06 129871 RK	R-5	Rural-5 Acre	Single Family Res-Combo
06 125112 RK	R-5	Rural-5 Acre	Single Family Res-Combo
06 100742 RK	R-5	Rural-5 Acre	Single Family Res-Combo
06 104238 RK	CITY	City	SFR-Basic
06 104232 RK	CITY	City	SFR-Basic
06 104237 RK	CITY	City	SFR-Basic
06 128306 RK	R-5	Rural-5 Acre	Single Family Res-Combo
06 127458 RK	CITY	City	SFR-Basic
06 100649 RK	CITY	City	SFR-Basic
06 135619 RK	CITY	City	SFR-Basic
06 101630 RK	R-5	Rural-5 Acre	Single Family Res-Combo
06 101087 RK	CITY	City	Single Family Res-Combo
06 125950 RK	R-5	Rural-5 Acre	Single Family Res-Combo
06 127398 RK	R-7,200	Residential 7,200 sq. ft.	Single Family Res-Combo
06 103088 RK	R-7,200	Residential 7,200 sq. ft.	Single Family Res-Combo
06 127181 RK	R-7,200	Residential 7,200 sq. ft.	Single Family Res-Combo
06 101167 RK	R-7,200	Residential 7,200 sq. ft.	Single Family Res-Combo
05 129023 RK	R-7,200	Residential 7,200 sq. ft.	Single Family Res-Combo
06 127182 RK	R-7,200	Residential 7,200 sq. ft.	Single Family Res-Combo
05 126140 RK	R-7,200	Residential 7,200 sq. ft.	Single Family Res-Combo
05 129019 RK	R-7,200	Residential 7,200 sq. ft.	Single Family Res-Combo
05 125219 RK	R-7,200	Residential 7,200 sq. ft.	Single Family Res-Combo
06 133793 RK	R-5	Rural-5 Acre	SFR-Basic
06 133790 RK	R-5	Rural-5 Acre	SFR-Basic
05 128607 RK	R-5	Rural-5 Acre	Single Family Res-Combo
06 101907 RK	R-9,600	Residential 9,600 sq. ft.	Single Family Res-Combo
06 102353 RK	R-9,600	Residential 9,600 sq. ft.	Single Family Res-Combo
06 101806 RK	RRT-10	Rural Resource Transition-10	Single Family Res-Combo
06 102351 RK	R-9,600	Residential 9,600 sq. ft.	Single Family Res-Combo
06 100747 RK	R-9,600	Residential 9,600 sq. ft.	Single Family Res-Combo
06 102789 RK	R-9,600	Residential 9,600 sq. ft.	Single Family Res-Combo
05 128385 RK	R-9,600	Residential 9,600 sq. ft.	Single Family Res-Combo
06 134558 RK	R-9,600(PRD)	Residential 9,600 sq. ft.	SFR-Basic
06 134559 RK	R-9,600(PRD)	Residential 9,600 sq. ft.	SFR-Basic
06 101546 RK	PRD-9,600	Residential 9,600 sq. ft.	Single Family Res-Combo
06 102254 RK	PRD-9,600	Residential 9,600 sq. ft.	Single Family Res-Combo
06 102791 RK	PRD-9,600	Residential 9,600 sq. ft.	Single Family Res-Combo
06 102256 RK	PRD-9,600	Residential 9,600 sq. ft.	Single Family Res-Combo
06 102257 RK	PRD-9,600	Residential 9,600 sq. ft.	Single Family Res-Combo

Accessory Dwelling Units

Index # - File Name: 1.0022 - Single Family Dwellings Data\_Snohomish County.pdf

05 127826 RK	PRD-9,600	Residential 9,600 sq. ft.	Single Family Res-Combo
05 127876 RK	PRD-9,600	Residential 9,600 sq. ft.	Single Family Res-Combo
06 100698 RK	PRD-9,600	Residential 9,600 sq. ft.	Single Family Res-Combo
06 100692 RK	PRD-9,600	Residential 9,600 sq. ft.	Single Family Res-Combo
05 123001 RK	R-5	Rural-5 Acre	SFR-Basic
05 122999 RK	R-5	Rural-5 Acre	SFR-Basic
05 122998 RK	R-5	Rural-5 Acre	SFR-Basic
05 122995 RK	R-5	Rural-5 Acre	SFR-Basic
06 100744 RK	R-5	Rural-5 Acre	Single Family Res-Combo
05 122480 RK	R-5	Rural-5 Acre	SFR-Basic
06 133665 RK	R-7,200	Residential 7,200 sq. ft.	SFR-Basic
06 133666 RK	R-7,200	Residential 7,200 sq. ft.	SFR-Basic
06 134330 RK	R-7,200	Residential 7,200 sq. ft.	SFR-Basic
06 133671 RK	R-7,200	Residential 7,200 sq. ft.	SFR-Basic
06 133565 RK	R-7,200	Residential 7,200 sq. ft.	SFR-Basic
06 133664 RK	R-7,200	Residential 7,200 sq. ft.	SFR-Basic
04 118944 000 01 RK	R-7,200	Residential 7,200 sq. ft.	Single Family Res-Combo
06 133669 RK	R-7,200	Residential 7,200 sq. ft.	SFR-Basic
06 133670 RK	R-7,200	Residential 7,200 sq. ft.	SFR-Basic
05 127869 RK	R-7,200	Residential 7,200 sq. ft.	Single Family Res-Combo
06 102476 RK	R-7,200	Residential 7,200 sq. ft.	Single Family Res-Combo
06 102469 RK	R-7,200	Residential 7,200 sq. ft.	SFR-Basic
06 102655 RK	R-7,200	Residential 7,200 sq. ft.	SFR-Basic
06 101051 RK	R-7,200	Residential 7,200 sq. ft.	SFR-Basic
06 101037 RK	R-7,200	Residential 7,200 sq. ft.	SFR-Basic
05 128495 RK	R-7,200	Residential 7,200 sq. ft.	Single Family Res-Combo
06 100745 RK	R-7,200	Residential 7,200 sq. ft.	Single Family Res-Combo
06 100743 RK	R-7,200	Residential 7,200 sq. ft.	Single Family Res-Combo
05 128502 RK	R-7,200	Residential 7,200 sq. ft.	Single Family Res-Combo
05 128499 RK	R-7,200	Residential 7,200 sq. ft.	Single Family Res-Combo
05 128500 RK	R-7,200	Residential 7,200 sq. ft.	Single Family Res-Combo
04 119405 000 01 RK	R-7,200	Residential 7,200 sq. ft.	Single Family Res-Combo
06 133668 RK	R-7,200	Residential 7,200 sq. ft.	SFR-Basic
06 103507 RK	R-7,200	Residential 7,200 sq. ft.	Single Family Res-Combo
06 103505 RK	R-7,200	Residential 7,200 sq. ft.	Single Family Res-Combo
06 103503 RK	R-7,200	Residential 7,200 sq. ft.	Single Family Res-Combo
06 132733 RK	R-7,200	Residential 7,200 sq. ft.	SFR-Basic
06 132734 RK	R-7,200	Residential 7,200 sq. ft.	SFR-Basic
06 132737 RK	R-7,200	Residential 7,200 sq. ft.	SFR-Basic
06 132738 RK	R-7,200	Residential 7,200 sq. ft.	SFR-Basic
06 132739 RK	R-7,200	Residential 7,200 sq. ft.	SFR-Basic
06 133395 RK	R-7,200	Residential 7,200 sq. ft.	SFR-Basic
06 132732 RK	R-7,200	Residential 7,200 sq. ft.	SFR-Basic
06 126571 RK	R-7,200	Residential 7,200 sq. ft.	SFR-Basic
06 128006 RK	R-7,200	Residential 7,200 sq. ft.	SFR-Basic
06 126568 RK	R-7,200	Residential 7,200 sq. ft.	SFR-Basic
06 126567 RK	R-7,200	Residential 7,200 sq. ft.	SFR-Basic

Accessory Dwelling Units

Index # - File Name: 1.0022 - Single Family Dwellings Data\_Snohomish County.pdf

06 127504 RK	R-7,200	Residential 7,200 sq. ft.	SFR-Basic
06 128664 RK	R-7,200	Residential 7,200 sq. ft.	SFR-Basic
06 128007 RK	R-7,200	Residential 7,200 sq. ft.	SFR-Basic
06 131140 RK	R-7,200	Residential 7,200 sq. ft.	SFR-Basic
06 131141 RK	R-7,200	Residential 7,200 sq. ft.	SFR-Basic
06 128015 RK	R-7,200	Residential 7,200 sq. ft.	Single Family Res-Combo
06 128017 RK	R-7,200	Residential 7,200 sq. ft.	Single Family Res-Combo
06 128019 RK	R-7,200	Residential 7,200 sq. ft.	Single Family Res-Combo
06 127073 RK	R-7,200	Residential 7,200 sq. ft.	Single Family Res-Combo
06 127076 RK	R-7,200	Residential 7,200 sq. ft.	Single Family Res-Combo
06 127080 RK	R-7,200	Residential 7,200 sq. ft.	Single Family Res-Combo
06 127946 RK	R-7,200	Residential 7,200 sq. ft.	Single Family Res-Combo
06 126715 RK	R-7,200	Residential 7,200 sq. ft.	Single Family Res-Combo
06 126717 RK	R-7,200	Residential 7,200 sq. ft.	Single Family Res-Combo
06 104047 RK	R-7,200	Residential 7,200 sq. ft.	Single Family Res-Combo
06 131142 RK	R-7,200	Residential 7,200 sq. ft.	SFR-Basic
06 129885 RK	R-7,200	Residential 7,200 sq. ft.	SFR-Basic
06 129886 RK	R-7,200	Residential 7,200 sq. ft.	SFR-Basic
06 128663 RK	R-7,200	Residential 7,200 sq. ft.	SFR-Basic
06 128665 RK	R-7,200	Residential 7,200 sq. ft.	SFR-Basic
06 127505 RK	R-7,200	Residential 7,200 sq. ft.	SFR-Basic
06 126569 RK	R-7,200	Residential 7,200 sq. ft.	SFR-Basic
06 126570 RK	R-7,200	Residential 7,200 sq. ft.	SFR-Basic
06 125834 RK	R-7,200	Residential 7,200 sq. ft.	SFR-Basic
06 128008 RK	R-7,200	Residential 7,200 sq. ft.	SFR-Basic
06 125835 RK	R-7,200	Residential 7,200 sq. ft.	SFR-Basic
06 131143 RK	R-7,200	Residential 7,200 sq. ft.	SFR-Basic
06 125836 RK	R-7,200	Residential 7,200 sq. ft.	SFR-Basic
06 125837 RK	R-7,200	Residential 7,200 sq. ft.	SFR-Basic
06 130479 RK	R-7,200	Residential 7,200 sq. ft.	SFR-Basic
06 130480 RK	R-7,200	Residential 7,200 sq. ft.	SFR-Basic
06 130481 RK	R-7,200	Residential 7,200 sq. ft.	SFR-Basic
06 130482 RK	R-7,200	Residential 7,200 sq. ft.	SFR-Basic
06 130483 RK	R-7,200	Residential 7,200 sq. ft.	SFR-Basic
06 130484 RK	R-7,200	Residential 7,200 sq. ft.	SFR-Basic
06 131144 RK	R-7,200	Residential 7,200 sq. ft.	SFR-Basic
06 132735 RK	R-7,200	Residential 7,200 sq. ft.	SFR-Basic
06 132736 RK	R-7,200	Residential 7,200 sq. ft.	SFR-Basic
06 133566 RK	R-7,200	Residential 7,200 sq. ft.	SFR-Basic
06 133567 RK	R-7,200	Residential 7,200 sq. ft.	SFR-Basic
06 133568 RK	R-7,200	Residential 7,200 sq. ft.	SFR-Basic
06 133569 RK	R-7,200	Residential 7,200 sq. ft.	SFR-Basic
06 133570 RK	R-7,200	Residential 7,200 sq. ft.	SFR-Basic
05 129141 RK	R-7,200	Residential 7,200 sq. ft.	Single Family Res-Combo
05 129142 RK	R-7,200	Residential 7,200 sq. ft.	Single Family Res-Combo
06 103592 RK	R-7,200	Residential 7,200 sq. ft.	SFR-Basic
06 103590 RK	R-7,200	Residential 7,200 sq. ft.	SFR-Basic

Accessory Dwelling Units

Index # - File Name: 1.0022 - Single Family Dwellings Data\_Snohomish County.pdf

06 103589 RK	R-7,200	Residential 7,200 sq. ft.	SFR-Basic
06 103591 RK	R-7,200	Residential 7,200 sq. ft.	SFR-Basic
06 102472 RK	R-7,200	Residential 7,200 sq. ft.	SFR-Basic
06 102471 RK	R-7,200	Residential 7,200 sq. ft.	SFR-Basic
06 102470 RK	R-7,200	Residential 7,200 sq. ft.	SFR-Basic
06 102473 RK	R-7,200	Residential 7,200 sq. ft.	SFR-Basic
06 101038 RK	R-7,200	Residential 7,200 sq. ft.	SFR-Basic
06 101039 RK	R-7,200	Residential 7,200 sq. ft.	SFR-Basic
06 102823 RK	CITY	City	Single Family Res-Combo
06 132777 RK	R-9,600(PRD)	Residential 9,600 sq. ft.	SFR-Basic
06 101088 RK	CITY	City	Single Family Res-Combo
05 128213 RK	R-5	Rural-5 Acre	SFR-Basic
05 128215 RK	R-5	Rural-5 Acre	SFR-Basic
06 126260 RK	R-5	Rural-5 Acre	Single Family Res-Combo
06 127258 RK	R-5	Rural-5 Acre	Single Family Res-Combo
06 102193 RK	R-7,200	Residential 7,200 sq. ft.	SFR-Basic
06 101422 RK	R-7,200	Residential 7,200 sq. ft.	SFR-Basic
05 127584 RK			Duplex-Combo
06 129050 RK	R-5	Rural-5 Acre	SFR-Basic
05 127675 RK	R-7,200	Residential 7,200 sq. ft.	Single Family Res-Combo
05 126139 RK	R-7,200	Residential 7,200 sq. ft.	Single Family Res-Combo
06 104226 RK	R-7,200	Residential 7,200 sq. ft.	Single Family Res-Combo
06 104227 RK	R-7,200	Residential 7,200 sq. ft.	Single Family Res-Combo
06 128536 RK	R-7,200	Residential 7,200 sq. ft.	Single Family Res-Combo
06 129049 RK	R-5	Rural-5 Acre	SFR-Basic
06 129047 RK	R-5	Rural-5 Acre	SFR-Basic
06 129048 RK	R-5	Rural-5 Acre	SFR-Basic
06 131280 RK	PRD-20,000	Residential 20,000 sq. ft.	SFR-Basic
06 131356 RK	R-5	Rural-5 Acre	SFR-Basic
06 131360 RK	R-5	Rural-5 Acre	SFR-Basic
06 101870 RK	PRD-20,000	Residential 20,000 sq. ft.	SFR-Basic
06 101871 RK	PRD-20,000	Residential 20,000 sq. ft.	SFR-Basic
06 101872 RK	PRD-20,000	Residential 20,000 sq. ft.	SFR-Basic
06 101873 RK	PRD-20,000	Residential 20,000 sq. ft.	SFR-Basic
06 129426 RK	PRD-20,000	Residential 20,000 sq. ft.	SFR-Basic
06 131281 RK	PRD-20,000	Residential 20,000 sq. ft.	SFR-Basic
06 131282 RK	PRD-20,000	Residential 20,000 sq. ft.	SFR-Basic
05 128918 RK	PRD-20,000	Residential 20,000 sq. ft.	SFR-Basic
05 128919 RK	PRD-20,000	Residential 20,000 sq. ft.	SFR-Basic
05 128920 RK	PRD-20,000	Residential 20,000 sq. ft.	SFR-Basic
05 128921 RK	PRD-20,000	Residential 20,000 sq. ft.	SFR-Basic
06 129425 RK	PRD-20,000	Residential 20,000 sq. ft.	SFR-Basic
06 131279 RK	PRD-20,000	Residential 20,000 sq. ft.	SFR-Basic
06 101874 RK	PRD-20,000	Residential 20,000 sq. ft.	SFR-Basic
06 101875 RK	PRD-20,000	Residential 20,000 sq. ft.	SFR-Basic
06 125221 RK	PRD-20,000	Residential 20,000 sq. ft.	SFR-Basic
05 129133 RK	PRD-20,000	Residential 20,000 sq. ft.	SFR-Basic

Accessory Dwelling Units

Index # - File Name: 1.0022 - Single Family Dwellings Data\_Snohomish County.pdf

06 102943 RK	PRD-20,000	Residential 20,000 sq. ft.	SFR-Basic
06 102944 RK	PRD-20,000	Residential 20,000 sq. ft.	SFR-Basic
06 129303 RK	PRD-20,000	Residential 20,000 sq. ft.	Single Family Res-Combo
06 129021 RK	PRD-20,000	Residential 20,000 sq. ft.	SFR-Basic
06 129022 RK	PRD-20,000	Residential 20,000 sq. ft.	SFR-Basic
06 127804 RK	PRD-20,000	Residential 20,000 sq. ft.	SFR-Basic
06 127805 RK	PRD-20,000	Residential 20,000 sq. ft.	SFR-Basic
06 101868 RK	PRD-20,000	Residential 20,000 sq. ft.	SFR-Basic
06 101869 RK	PRD-20,000	Residential 20,000 sq. ft.	SFR-Basic
06 102474 RK	PRD-20,000	Residential 20,000 sq. ft.	SFR-Basic
05 129017 RK	PRD-20,000	Residential 20,000 sq. ft.	SFR-Basic
06 128290 RK	A-10	Agriculture-10 Acre	Single Family Res-Combo
05 128813 RK	PRD-20,000	Residential 20,000 sq. ft.	SFR-Basic
05 101835 RK	R-5	Rural-5 Acre	Single Family Res-Combo
06 101413 RK	PRD-20,000	Residential 20,000 sq. ft.	SFR-Basic
06 101414 RK	PRD-20,000	Residential 20,000 sq. ft.	SFR-Basic
06 101415 RK	PRD-20,000	Residential 20,000 sq. ft.	SFR-Basic
06 101416 RK	PRD-20,000	Residential 20,000 sq. ft.	SFR-Basic
06 101419 RK	PRD-20,000	Residential 20,000 sq. ft.	SFR-Basic
06 101420 RK	PRD-20,000	Residential 20,000 sq. ft.	SFR-Basic
06 101421 RK	PRD-20,000	Residential 20,000 sq. ft.	SFR-Basic
06 101423 RK	PRD-20,000	Residential 20,000 sq. ft.	SFR-Basic
06 101424 RK	PRD-20,000	Residential 20,000 sq. ft.	SFR-Basic
06 101425 RK	PRD-20,000	Residential 20,000 sq. ft.	SFR-Basic
06 101426 RK	PRD-20,000	Residential 20,000 sq. ft.	SFR-Basic
06 101427 RK	PRD-20,000	Residential 20,000 sq. ft.	SFR-Basic
06 101428 RK	PRD-20,000	Residential 20,000 sq. ft.	SFR-Basic
06 101429 RK	PRD-20,000	Residential 20,000 sq. ft.	SFR-Basic
06 101431 RK	PRD-20,000	Residential 20,000 sq. ft.	SFR-Basic
06 101432 RK	PRD-20,000	Residential 20,000 sq. ft.	SFR-Basic
06 101433 RK	PRD-20,000	Residential 20,000 sq. ft.	SFR-Basic
06 100869 RK	PRD-20,000	Residential 20,000 sq. ft.	SFR-Basic
06 100027 RK	PRD-20,000	Residential 20,000 sq. ft.	SFR-Basic
06 100019 RK	PRD-20,000	Residential 20,000 sq. ft.	SFR-Basic
06 132812 RK	R-7,200	Residential 7,200 sq. ft.	SFR-Basic
06 133238 RK	R-7,200	Residential 7,200 sq. ft.	SFR-Basic
06 133797 RK	R-7,200	Residential 7,200 sq. ft.	SFR-Basic
06 126263 RK	R-7,200	Residential 7,200 sq. ft.	SFR-Basic
06 126266 RK	R-7,200	Residential 7,200 sq. ft.	SFR-Basic
06 129260 RK	R-7,200	Residential 7,200 sq. ft.	SFR-Basic
06 103199 RK	R-7,200	Residential 7,200 sq. ft.	SFR-Basic
06 125008 RK	R-9,600(PRD)	Residential 9,600 sq. ft.	SFR-Basic
06 102981 RK	R-9,600(PRD)	Residential 9,600 sq. ft.	SFR-Basic
06 126474 RK	R-9,600(PRD)	Residential 9,600 sq. ft.	SFR-Basic
06 125005 RK	R-9,600(PRD)	Residential 9,600 sq. ft.	SFR-Basic
06 103216 RK	R-7,200	Residential 7,200 sq. ft.	SFR-Basic
06 103217 RK	R-7,200	Residential 7,200 sq. ft.	SFR-Basic

Accessory Dwelling Units

Index # - File Name: 1.0022 - Single Family Dwellings Data\_Snohomish County.pdf

06 103218 RK	R-7,200	Residential 7,200 sq. ft.	SFR-Basic
06 103219 RK	R-7,200	Residential 7,200 sq. ft.	SFR-Basic
06 103220 RK	R-7,200	Residential 7,200 sq. ft.	SFR-Basic
06 103221 RK	R-7,200	Residential 7,200 sq. ft.	SFR-Basic
06 125006 RK	R-9,600(PRD)	Residential 9,600 sq. ft.	SFR-Basic
06 125007 RK	R-9,600(PRD)	Residential 9,600 sq. ft.	SFR-Basic
06 132782 RK	R-9,600(PRD)	Residential 9,600 sq. ft.	SFR-Basic
06 132781 RK	R-9,600(PRD)	Residential 9,600 sq. ft.	SFR-Basic
06 131269 RK	R-9,600(PRD)	Residential 9,600 sq. ft.	SFR-Basic
06 129460 RK	R-9,600(PRD)	Residential 9,600 sq. ft.	SFR-Basic
06 131270 RK	R-9,600(PRD)	Residential 9,600 sq. ft.	SFR-Basic
06 131271 RK	R-9,600(PRD)	Residential 9,600 sq. ft.	SFR-Basic
06 131272 RK	R-9,600(PRD)	Residential 9,600 sq. ft.	SFR-Basic
06 132783 RK	R-9,600(PRD)	Residential 9,600 sq. ft.	SFR-Basic
06 132784 RK	R-9,600(PRD)	Residential 9,600 sq. ft.	SFR-Basic
06 132779 RK	R-9,600(PRD)	Residential 9,600 sq. ft.	SFR-Basic
06 132780 RK	R-9,600(PRD)	Residential 9,600 sq. ft.	SFR-Basic
06 102982 RK	R-9,600(PRD)	Residential 9,600 sq. ft.	SFR-Basic
06 135449 RK	R-9,600(PRD)	Residential 9,600 sq. ft.	SFR-Basic
06 102243 RK	CITY	City	SFR-Basic
06 102978 RK	R-9,600(PRD)	Residential 9,600 sq. ft.	SFR-Basic
06 102979 RK	R-9,600(PRD)	Residential 9,600 sq. ft.	SFR-Basic
06 125004 RK	R-9,600(PRD)	Residential 9,600 sq. ft.	SFR-Basic
06 126471 RK	R-9,600(PRD)	Residential 9,600 sq. ft.	SFR-Basic
06 126472 RK	R-9,600(PRD)	Residential 9,600 sq. ft.	SFR-Basic
06 126473 RK	R-9,600(PRD)	Residential 9,600 sq. ft.	SFR-Basic
06 130148 RK	R-9,600(PRD)	Residential 9,600 sq. ft.	SFR-Basic
06 127975 RK	R-9,600(PRD)	Residential 9,600 sq. ft.	SFR-Basic
06 129200 RK	R-9,600(PRD)	Residential 9,600 sq. ft.	SFR-Basic
06 129457 RK	R-9,600(PRD)	Residential 9,600 sq. ft.	SFR-Basic
06 129458 RK	R-9,600(PRD)	Residential 9,600 sq. ft.	SFR-Basic
06 129459 RK	R-9,600(PRD)	Residential 9,600 sq. ft.	SFR-Basic
06 127977 RK	R-9,600(PRD)	Residential 9,600 sq. ft.	SFR-Basic
06 127973 RK	R-9,600(PRD)	Residential 9,600 sq. ft.	SFR-Basic
06 102980 RK	R-9,600(PRD)	Residential 9,600 sq. ft.	SFR-Basic
06 103240 RK	R-7,200	Residential 7,200 sq. ft.	SFR-Basic
06 128683 RK	R-7,200	Residential 7,200 sq. ft.	SFR-Basic
06 100395 RK	R-7,200	Residential 7,200 sq. ft.	SFR-Basic
06 127993 RK	R-7,200	Residential 7,200 sq. ft.	SFR-Basic
06 100393 RK	R-7,200	Residential 7,200 sq. ft.	SFR-Basic
06 101109 RK	R-7,200	Residential 7,200 sq. ft.	SFR-Basic
06 125818 RK	R-7,200	Residential 7,200 sq. ft.	SFR-Basic
06 126800 RK	R-7,200	Residential 7,200 sq. ft.	SFR-Basic
06 134560 RK	R-9,600(PRD)	Residential 9,600 sq. ft.	SFR-Basic
06 125819 RK	R-7,200	Residential 7,200 sq. ft.	SFR-Basic
06 103222 RK	R-7,200	Residential 7,200 sq. ft.	SFR-Basic
06 103362 RK	R-7,200	Residential 7,200 sq. ft.	SFR-Basic



Accessory Dwelling Units

Index # - File Name: 1.0022 - Single Family Dwellings Data\_Snohomish County.pdf

06 103223 RK	R-7,200	Residential 7,200 sq. ft.	SFR-Basic
06 103361 RK	R-7,200	Residential 7,200 sq. ft.	SFR-Basic
06 103224 RK	R-7,200	Residential 7,200 sq. ft.	SFR-Basic
06 103226 RK	R-7,200	Residential 7,200 sq. ft.	SFR-Basic
06 103227 RK	R-7,200	Residential 7,200 sq. ft.	SFR-Basic
06 103228 RK	R-7,200	Residential 7,200 sq. ft.	SFR-Basic
06 103229 RK	R-7,200	Residential 7,200 sq. ft.	SFR-Basic
06 103230 RK	R-7,200	Residential 7,200 sq. ft.	SFR-Basic
06 125082 RK	R-7,200	Residential 7,200 sq. ft.	SFR-Basic
04 121465 RK	R-7,200	Residential 7,200 sq. ft.	SFR-Basic
04 121777 RK	R-7,200	Residential 7,200 sq. ft.	SFR-Basic
04 121771 RK	R-7,200	Residential 7,200 sq. ft.	SFR-Basic
04 121772 RK	R-7,200	Residential 7,200 sq. ft.	SFR-Basic
06 135650 RK	R-7,200	Residential 7,200 sq. ft.	SFR-Basic
06 135601 RK	R-7,200	Residential 7,200 sq. ft.	SFR-Basic
04 121599 RK	R-7,200	Residential 7,200 sq. ft.	SFR-Basic
04 121601 RK	R-7,200	Residential 7,200 sq. ft.	SFR-Basic
04 121760 RK	R-7,200	Residential 7,200 sq. ft.	SFR-Basic
04 121758 RK	R-7,200	Residential 7,200 sq. ft.	SFR-Basic
04 121764 RK	R-7,200	Residential 7,200 sq. ft.	SFR-Basic
06 100629 RK	LDMR	Low Density Multiple Reside	SFR-Basic
06 102838 RK	LDMR	Low Density Multiple Reside	SFR-Basic
06 102839 RK	LDMR	Low Density Multiple Reside	SFR-Basic
06 102840 RK	LDMR	Low Density Multiple Reside	SFR-Basic
06 100637 RK	LDMR	Low Density Multiple Reside	SFR-Basic
05 128659 RK	R-5	Rural-5 Acre	SFR-Basic
05 128660 RK	R-5	Rural-5 Acre	SFR-Basic
05 124858 RK	R-5	Rural-5 Acre	Single Family Res-Combo
06 131337 RK	R-7,200	Residential 7,200 sq. ft.	SFR-Basic
06 102957 RK	R-7,200	Residential 7,200 sq. ft.	SFR-Basic
06 126722 RK	R-7,200	Residential 7,200 sq. ft.	Single Family Res-Combo
06 101303 RK	R-7,200	Residential 7,200 sq. ft.	SFR-Basic
06 127048 RK	R-7,200	Residential 7,200 sq. ft.	SFR-Basic
06 101042 RK	R-7,200	Residential 7,200 sq. ft.	Single Family Res-Combo
06 103257 RK	R-7,200	Residential 7,200 sq. ft.	SFR-Basic
06 103385 RK	R-5	Rural-5 Acre	SFR-Basic
06 130431 RK	R-5	Rural-5 Acre	Single Family Res-Combo
06 100420 RK	R-5	Rural-5 Acre	SFR-Basic
06 100421 RK	R-5	Rural-5 Acre	SFR-Basic
06 101544 RK	R-5	Rural-5 Acre	Single Family Res-Combo
06 102479 RK	R-5	Rural-5 Acre	SFR-Basic
03 107337 000 01 RK	R-5	Rural-5 Acre	Single Family Res-Combo
06 101835 RK	R-5	Rural-5 Acre	Single Family Res-Combo
06 132650 RK	R-5	Rural-5 Acre	Single Family Res-Combo
06 102765 RK	R-5	Rural-5 Acre	Single Family Res-Combo
04 100330 000 01 RK	R-5	Rural-5 Acre	Single Family Res-Combo
06 127487 RK	R-5	Rural-5 Acre	Single Family Res-Combo

Accessory Dwelling Units

Index # - File Name: 1.0022 - Single Family Dwellings Data\_Snohomish County.pdf

06 130478 RK	R-5	Rural-5 Acre	Single Family Res-Combo
06 103017 RK	R-5	Rural-5 Acre	Single Family Res-Combo
05 127857 RK	R-5	Rural-5 Acre	Single Family Res-Combo
06 128551 RK	R-7,200	Residential 7,200 sq. ft.	SFR-Basic
06 128549 RK	R-7,200	Residential 7,200 sq. ft.	SFR-Basic
06 127507 MH	A-10	Agriculture-10 Acre	Double Wide
06 102514 MH	R-5	Rural-5 Acre	Double Wide
06 102280 MH	R-5	Rural-5 Acre	Triple Wide
05 121168 RK	R-5	Rural-5 Acre	Single Family Res-Combo
06 103501 RK	F and R	Forestry and Recreation	Single Family Res-Combo
04 116304 000 01 RK	R-5	Rural-5 Acre	Single Family Res-Combo
06 129029 RK	R-5	Rural-5 Acre	Single Family Res-Combo
06 128096 RK	R-5	Rural-5 Acre	Single Family Res-Combo
06 102647 MH	R-5	Rural-5 Acre	Triple Wide
06 126632 RK	R-5	Rural-5 Acre	Duplex-Combo
06 101638 RK	R-5	Rural-5 Acre	Single Family Res-Combo
05 128512 RK	R-5	Rural-5 Acre	Single Family Res-Combo
05 128508 RK	R-5	Rural-5 Acre	Single Family Res-Combo
05 128517 RK	R-5	Rural-5 Acre	Single Family Res-Combo
06 132109 RK	R-5	Rural-5 Acre	Single Family Res-Combo
06 102975 RK	R-5	Rural-5 Acre	Single Family Res-Combo
05 129291 RK	R-5	Rural-5 Acre	Single Family Res-Combo
06 127168 RK	R-5	Rural-5 Acre	Single Family Res-Combo
06 129657 RK	R-5	Rural-5 Acre	Single Family Res-Combo
06 125897 001 00 MH	R-5	Rural-5 Acre	Double Wide
06 129435 RK	CITY	City	Single Family Res-Combo
06 132326 RK	R-5	Rural-5 Acre	Single Family Res-Combo
06 104093 RK	R-5	Rural-5 Acre	SFR-Basic
05 123658 RK	WFB	Waterfront Beach	Single Family Res-Combo
05 128067 MH	A-10 : R-5	Agriculture-10 Acre : Rural-5	Triple Wide
05 127429 RK	PRD-9,600	Residential 9,600 sq. ft.	Single Family Res-Combo
05 127433 RK	PRD-9,600	Residential 9,600 sq. ft.	Single Family Res-Combo
05 127436 RK	PRD-9,600	Residential 9,600 sq. ft.	Single Family Res-Combo
05 127438 RK	PRD-9,600	Residential 9,600 sq. ft.	Single Family Res-Combo
05 127437 RK	PRD-9,600	Residential 9,600 sq. ft.	SFR-Basic
06 127831 RK	R-5	Rural-5 Acre	Accessory Apt Detached-Combo
06 127311 RK	R-5	Rural-5 Acre	Single Family Res-Combo
05 100643 MH	R-5	Rural-5 Acre	Double Wide
05 127997 RK	R-5	Rural-5 Acre	SFR-Basic
06 125794 RK	F	Forestry	SFR-Basic
06 130078 RK	A-10	Agriculture-10 Acre	Single Family Res-Combo
06 132128 RK	R-5	Rural-5 Acre	Single Family Res-Combo
06 131149 RK	F	Forestry	Single Family Res-Combo
06 103388 RK	R-5	Rural-5 Acre	Single Family Res-Combo
06 126804 RK	R-5	Rural-5 Acre	Single Family Res-Combo
06 126803 RK	R-5	Rural-5 Acre	Single Family Res-Combo
05 128123 RK	R-5	Rural-5 Acre	Single Family Res-Combo

Accessory Dwelling Units

Index # - File Name: 1.0022 - Single Family Dwellings Data\_Snohomish County.pdf

06 102309 RK	R-5	Rural-5 Acre	Single Family Res-Combo
06 126051 RK	R-5	Rural-5 Acre	Single Family Res-Combo
05 127326 000 01 RK	R-5	Rural-5 Acre	Single Family Res-Combo
05 128129 RK	R-5	Rural-5 Acre	Single Family Res-Combo
06 129924 RK	R-5	Rural-5 Acre	Single Family Res-Combo
06 125355 RK	R-5	Rural-5 Acre	Single Family Res-Combo
05 127602 RK	R-5	Rural-5 Acre	Single Family Res-Combo
06 102111 RK	F	Forestry	SFR-Basic
06 102112 RK	F	Forestry	SFR-Basic
06 125795 RK	F	Forestry	SFR-Basic
05 116464 RK	F	Forestry	SFR-Basic
06 101864 RK	F	Forestry	SFR-Basic
06 101862 RK	F	Forestry	SFR-Basic
06 100615 RK	R-5	Rural-5 Acre	Single Family Res-Combo
06 103256 RK	R-5	Rural-5 Acre	Single Family Res-Combo
06 129017 RK	R-5	Rural-5 Acre	Single Family Res-Combo
06 102891 RK	R-5	Rural-5 Acre	Single Family Res-Combo
06 131795 RK	R-5	Rural-5 Acre	Single Family Res-Combo
06 102321 RK	R-5	Rural-5 Acre	Single Family Res-Combo
05 122095 RK	R-5	Rural-5 Acre	Single Family Res-Combo
06 129653 RK	R-5	Rural-5 Acre	Single Family Res-Combo
06 125894 RK	R-5	Rural-5 Acre	Single Family Res-Combo
05 125952 RK	CITY	City	Single Family Res-Combo
05 124289 RK	R-5	Rural-5 Acre	Single Family Res-Combo
06 102113 RK	R-5	Rural-5 Acre	Single Family Res-Combo
06 131599 RK	R-5	Rural-5 Acre	Single Family Res-Combo
06 101773 RK	R-5	Rural-5 Acre	Single Family Res-Combo
06 125658 RK	R-5	Rural-5 Acre	Single Family Res-Combo
06 103594 RK	R-5	Rural-5 Acre	Single Family Res-Combo
05 127985 RK	R-5	Rural-5 Acre	Single Family Res-Combo
06 104050 RK	R-5	Rural-5 Acre	Single Family Res-Combo
06 102703 RK	R-5	Rural-5 Acre	Single Family Res-Combo
05 122092 RK	R-5	Rural-5 Acre	SFR-Basic
04 118756 000 01 RK	R-5	Rural-5 Acre	Single Family Res-Combo
06 130897 RK	RRT-10	Rural Resource Transition-10	Single Family Res-Combo
06 100689 MH	R-5	Rural-5 Acre	Single Wide
06 102179 RK	R-9,600	Residential 9,600 sq. ft.	Single Family Res-Combo
06 129748 MH	R-5	Rural-5 Acre	Triple Wide
06 130588 RK	R-5	Rural-5 Acre	Single Family Res-Combo
06 101143 RK	F and R	Forestry and Recreation	Single Family Res-Combo
05 127964 RK	R-5	Rural-5 Acre	Single Family Res-Combo
04 110852 000 01 RK	R-5	Rural-5 Acre	Single Family Res-Combo
05 124792 RK	F	Forestry	Accessory Apt Detached-Combo
04 108526 RK	R-5	Rural-5 Acre	Single Family Res-Combo
06 129920 RK	F	Forestry	Single Family Res-Combo
05 129348 RK	R-5	Rural-5 Acre	Single Family Res-Combo
06 129592 MH	R-5	Rural-5 Acre	Triple Wide

Accessory Dwelling Units

Index # - File Name: 1.0022 - Single Family Dwellings Data\_Snohomish County.pdf

06 100176 RK	R-5	Rural-5 Acre	Single Family Res-Combo
06 100612 RK	R-5	Rural-5 Acre	Single Family Res-Combo
06 126411 RK	R-5	Rural-5 Acre	Single Family Res-Combo
06 103108 RK	F	Forestry	Single Family Res-Combo
06 128077 RK	F	Forestry	Single Family Res-Combo
06 127335 RK	R-5	Rural-5 Acre	Single Family Res-Combo
05 127600 RK	A-10	Agriculture-10 Acre	Single Family Res-Combo
06 127007 RK	R-9,600	Residential 9,600 sq. ft.	Single Family Res-Combo
06 103384 RK	R-5	Rural-5 Acre	Single Family Res-Combo
05 128935 MH	F	Forestry	Double Wide
06 103393 RK	R-5	Rural-5 Acre	Duplex-Combo
06 103569 RK	R-5	Rural-5 Acre	SFR-Basic
06 102432 RK	R-5	Rural-5 Acre	Single Family Res-Combo
05 128654 MH	R-5	Rural-5 Acre	Triple Wide
06 128002 RK	R-7,200	Residential 7,200 sq. ft.	Single Family Res-Combo
06 126693 RK	R-5	Rural-5 Acre	Single Family Res-Combo
06 132166 RK	R-5	Rural-5 Acre	Single Family Res-Combo
05 129120 RK	R-5	Rural-5 Acre	Single Family Res-Combo
06 103137 RK	R-5	Rural-5 Acre	Single Family Res-Combo
06 130690 RK	R-5	Rural-5 Acre	Single Family Res-Combo
06 102609 RK	LDMR	Low Density Multiple Reside	Duplex-Combo
06 126786 RK	R-5	Rural-5 Acre	Single Family Res-Combo
06 129432 RK	R-9,600	Residential 9,600 sq. ft.	Single Family Res-Combo
06 129434 RK	R-9,600	Residential 9,600 sq. ft.	Single Family Res-Combo
05 128765 MH	F	Forestry	Double Wide
06 102576 RK	R-5	Rural-5 Acre	Single Family Res-Combo
06 127941 RK	R-5	Rural-5 Acre	Single Family Res-Combo
03 110141 000 01 MH	R-5	Rural-5 Acre	Double Wide
06 126200 RK	R-5	Rural-5 Acre	Single Family Res-Combo
05 129102 RK	R-5	Rural-5 Acre	Single Family Res-Combo
06 129023 RK	R-5	Rural-5 Acre	Single Family Res-Combo
05 120798 RK	R-5	Rural-5 Acre	Single Family Res-Combo
05 129037 RK	R-7,200	Residential 7,200 sq. ft.	Duplex-Combo
06 131087 RK	R-9,600	Residential 9,600 sq. ft.	Single Family Res-Combo
06 129272 RK	R-12,500	Residential 12,500 sq. ft.	Single Family Res-Combo
06 133401 RK	R-12,500	Residential 12,500 sq. ft.	SFR-Basic
06 126831 RK	R-12,500	Residential 12,500 sq. ft.	Single Family Res-Combo
06 135603 RK	R-8,400	Residential 8,400 sq. ft.	Single Family Res-Combo
06 126381 RK	R-7,200	Residential 7,200 sq. ft.	Single Family Res-Combo
04 114036 000 01 RK	R-5	Rural-5 Acre	Single Family Res-Combo
05 129320 MH	R-5	Rural-5 Acre	Single Wide
05 126593 RK	R-5	Rural-5 Acre	Single Family Res-Combo
06 103903 RK	R-5	Rural-5 Acre	Single Family Res-Combo
05 123642 RK	R-5	Rural-5 Acre	Accessory Apt Detached-Combo
06 128056 RK	R-5	Rural-5 Acre	Single Family Res-Combo
06 101644 MH	R-5	Rural-5 Acre	Double Wide
06 131064 MH	R-5	Rural-5 Acre	Double Wide

Accessory Dwelling Units

Index # - File Name: 1.0022 - Single Family Dwellings Data\_Snohomish County.pdf

06 130862 RK	R-5	Rural-5 Acre	Single Family Res-Combo
06 100371 RK	R-8,400	Residential 8,400 sq. ft.	Single Family Res-Combo
06 129263 RK	R-5	Rural-5 Acre	Single Family Res-Combo
05 128927 RK	R-5	Rural-5 Acre	Single Family Res-Combo
06 130885 RK	R-5	Rural-5 Acre	Single Family Res-Combo
05 125276 RK	R-5	Rural-5 Acre	Single Family Res-Combo
04 112495 000 01 RK	R-5	Rural-5 Acre	Single Family Res-Combo
06 101580 RK	R-5	Rural-5 Acre	Single Family Res-Combo
06 128344 RK	A-10	Agriculture-10 Acre	Single Family Res-Combo
05 123202 RK	R-5	Rural-5 Acre	Single Family Res-Combo
06 126414 RK	R-5	Rural-5 Acre	SFR-Basic
06 131177 RK	F	Forestry	Single Family Res-Combo
05 126428 MH	F	Forestry	Triple Wide
06 134617 RK	R-5	Rural-5 Acre	Single Family Res-Combo
06 103104 RK	R-5	Rural-5 Acre	Single Family Res-Combo
06 130795 RK	R-5	Rural-5 Acre	Single Family Res-Combo
06 131682 RK	R-5	Rural-5 Acre	Single Family Res-Combo
05 123599 RK	LDMR	Low Density Multiple Reside	Single Family Res-Combo
06 125280 RK	R-5	Rural-5 Acre	SFR-Basic
06 103283 RK	F	Forestry	Single Family Res-Combo
06 102477 RK	R-7,200	Residential 7,200 sq. ft.	Single Family Res-Combo
06 104025 RK	R-9,600	Residential 9,600 sq. ft.	Single Family Res-Combo
06 131248 RK	R-5	Rural-5 Acre	SFR-Basic
06 129593 RK	R-5	Rural-5 Acre	Single Family Res-Combo
06 103950 RK	F	Forestry	SFR-Basic
06 103948 RK	F	Forestry	SFR-Basic
06 130064 RK	LDMR	Low Density Multiple Reside	Single Family Res-Combo
06 102890 RK	R-7,200	Residential 7,200 sq. ft.	Single Family Res-Combo
06 101060 RK	R-7,200	Residential 7,200 sq. ft.	Single Family Res-Combo
06 103083 RK	R-7,200	Residential 7,200 sq. ft.	Duplex-Basic
05 125279 RK	R-7,200	Residential 7,200 sq. ft.	SFR-Basic
05 125278 RK	R-7,200	Residential 7,200 sq. ft.	SFR-Basic
05 128374 RK	R-7,200	Residential 7,200 sq. ft.	Single Family Res-Combo
06 129787 RK	R-5	Rural-5 Acre	Single Family Res-Combo
06 133080 RK	R-5	Rural-5 Acre	Single Family Res-Combo
06 130557 RK	R-5	Rural-5 Acre	Single Family Res-Combo
05 128172 RK	R-9,600	Residential 9,600 sq. ft.	Single Family Res-Combo
06 129465 RK	R-5	Rural-5 Acre	Single Family Res-Combo
06 103234 RK	R-5	Rural-5 Acre	Single Family Res-Combo
06 132607 RK	R-5	Rural-5 Acre	Single Family Res-Combo
03 107636 000 01 RK	R-5	Rural-5 Acre	Single Family Res-Combo
05 128670 MH	F	Forestry	Double Wide
06 128456 RK	PRD-9,600	Residential 9,600 sq. ft.	Single Family Res-Combo
06 101561 RK	R-5	Rural-5 Acre	Single Family Res-Combo
06 126432 RK	R-5	Rural-5 Acre	Single Family Res-Combo
06 102305 RK	R-5	Rural-5 Acre	Accessory Apt Detached-Combo
06 127333 MH	R-5	Rural-5 Acre	Double Wide

Accessory Dwelling Units

Index # - File Name: 1.0022 - Single Family Dwellings Data\_Snohomish County.pdf

06 127988 RK	R-5	Rural-5 Acre	Single Family Res-Combo
06 132327 RK	R-5	Rural-5 Acre	Single Family Res-Combo
06 129630 MH	R-5	Rural-5 Acre	Double Wide
06 126737 RK	R-5	Rural-5 Acre	Single Family Res-Combo
06 101606 RK	R-5	Rural-5 Acre	Single Family Res-Combo
06 103984 RK	RC	Rural Conservation	Accessory Apt Detached-Combo
06 125296 RK	RC	Rural Conservation	Single Family Res-Combo
06 102793 RK	R-5	Rural-5 Acre	Single Family Res-Combo
06 101748 RK	RRT-10	Rural Resource Transition-10	Single Family Res-Combo
06 103621 RK	R-9,600	Residential 9,600 sq. ft.	SFR-Basic
06 101813 RK	R-5	Rural-5 Acre	Single Family Res-Combo
06 133738 RK	R-5	Rural-5 Acre	Single Family Res-Combo
04 111299 000 01 MH	CITY	City	Double Wide
06 129681 RK	R-5	Rural-5 Acre	Single Family Res-Combo
06 126875 RK	R-5	Rural-5 Acre	Single Family Res-Combo
06 129269 MH	RRT-10	Rural Resource Transition-10	Double Wide
06 128537 RK	R-5	Rural-5 Acre	Single Family Res-Combo
06 116297 RK	RRT-10	Rural Resource Transition-10	Single Family Res-Combo
06 103837 RK	R-5	Rural-5 Acre	Single Family Res-Combo
06 102105 RK	A-10	Agriculture-10 Acre	Single Family Res-Combo
05 125402 RK	RRT-10	Rural Resource Transition-10	Single Family Res-Combo
06 103112 MH	R-5	Rural-5 Acre	Double Wide
06 133273 RK	R-5	Rural-5 Acre	Single Family Res-Combo
06 100370 RK	R-5	Rural-5 Acre	Single Family Res-Combo
06 100868 RK	CITY	City	Duplex-Combo
06 102628 MH	R-5	Rural-5 Acre	Triple Wide
06 129642 RK	CITY	City	Single Family Res-Combo
06 126373 RK	R-5	Rural-5 Acre	Single Family Res-Combo
03 108725 000 01 RK	R-5	Rural-5 Acre	Single Family Res-Combo
06 101011 RK	R-5	Rural-5 Acre	Duplex-Combo
06 128333 RK	CITY	City	Accessory Apt Detached-Combo
06 103428 RK	R-5	Rural-5 Acre	Single Family Res-Combo
05 124019 RK	CITY	City	SFR-Basic
06 127856 RK	R-5	Rural-5 Acre	Single Family Res-Combo
06 126175 RK	R-7,200	Residential 7,200 sq. ft.	Single Family Res-Combo
06 129849 RK	R-5	Rural-5 Acre	Single Family Res-Combo
06 129607 RK	R-5	Rural-5 Acre	Single Family Res-Combo
05 125893 RK	R-5	Rural-5 Acre	Single Family Res-Combo
05 125725 RK	R-5	Rural-5 Acre	Single Family Res-Combo
06 125500 RK	R-5	Rural-5 Acre	Single Family Res-Combo
06 130842 RK	R-5	Rural-5 Acre	Single Family Res-Combo
06 128105 RK	R-5	Rural-5 Acre	Single Family Res-Combo
06 125693 RK	R-5	Rural-5 Acre	Single Family Res-Combo
06 130837 RK	R-5	Rural-5 Acre	Single Family Res-Combo
06 102255 RK	R-5	Rural-5 Acre	Single Family Res-Combo
06 102324 RK	R-5	Rural-5 Acre	Single Family Res-Combo
06 127528 RK	R-5	Rural-5 Acre	Single Family Res-Combo

Accessory Dwelling Units

Index # - File Name: 1.0022 - Single Family Dwellings Data\_Snohomish County.pdf

05 125889 RK	R-5	Rural-5 Acre	Single Family Res-Combo
05 125907 RK	R-5	Rural-5 Acre	Single Family Res-Combo
06 129329 RK	R-5	Rural-5 Acre	Single Family Res-Combo
06 130456 RK	R-5	Rural-5 Acre	Single Family Res-Combo
05 128233 MH	R-5	Rural-5 Acre	Double Wide
03 110476 000 01 RK	R-5	Rural-5 Acre	Single Family Res-Combo
05 123438 MH	R-5	Rural-5 Acre	Single Wide
06 103102 RK	RRT-10	Rural Resource Transition-10	Single Family Res-Combo
06 129579 RK	SA-1	Suburban Agriculture-1 Acre	Single Family Res-Combo
06 132322 RK	R-5	Rural-5 Acre	Single Family Res-Combo
05 121329 RK	R-5	Rural-5 Acre	Single Family Res-Combo
05 124398 RK	R-5	Rural-5 Acre	Single Family Res-Combo
06 102538 RK	R-5	Rural-5 Acre	Single Family Res-Combo
06 102448 RK	R-5	Rural-5 Acre	Single Family Res-Combo
06 104019 RK	R-5	Rural-5 Acre	Single Family Res-Combo
06 125002 MH	R-5	Rural-5 Acre	Triple Wide
06 125010 MH	R-5	Rural-5 Acre	Double Wide
06 133672 RK	R-5	Rural-5 Acre	Single Family Res-Combo
04 118101 RK	R-5	Rural-5 Acre	Single Family Res-Combo
06 131648 RK	R-5	Rural-5 Acre	Single Family Res-Combo
06 129503 MH	R-5	Rural-5 Acre	Double Wide
06 128323 RK	R-5	Rural-5 Acre	Single Family Res-Combo
05 122222 RK	R-5	Rural-5 Acre	Single Family Res-Combo
06 101743 MH	R-5	Rural-5 Acre	Double Wide
06 102927 RK	R-5	Rural-5 Acre	Single Family Res-Combo
06 131068 RK	R-5	Rural-5 Acre	Single Family Res-Combo
05 125430 MH	R-5	Rural-5 Acre	Double Wide
06 129011 RK	R-5	Rural-5 Acre	Single Family Res-Combo
06 132064 MH	R-5	Rural-5 Acre	Triple Wide
05 127595 MH	R-5	Rural-5 Acre	Double Wide
06 132056 RK	R-5	Rural-5 Acre	SFR-Basic
05 125693 MH	A-10	Agriculture-10 Acre	Double Wide
06 127772 RK	R-5	Rural-5 Acre	SFR-Basic
06 101577 RK	R-5	Rural-5 Acre	Duplex-Combo
06 129949 RK	R-5	Rural-5 Acre	Single Family Res-Combo
06 127220 RK	R-5	Rural-5 Acre	Single Family Res-Combo
06 101449 RK	R-5	Rural-5 Acre	Single Family Res-Combo
06 128720 RK	R-5	Rural-5 Acre	Single Family Res-Combo
06 127322 RK	R-5	Rural-5 Acre	Single Family Res-Combo
05 120519 RK	R-5	Rural-5 Acre	Single Family Res-Combo
05 129316 RK	R-5	Rural-5 Acre	Single Family Res-Combo
06 129616 RK	R-5	Rural-5 Acre	Single Family Res-Combo
06 126045 RK	R-5	Rural-5 Acre	Single Family Res-Combo
05 120906 RK	R-5	Rural-5 Acre	Single Family Res-Combo
05 126555 RK	R-5	Rural-5 Acre	Single Family Res-Combo
06 126740 RK	R-5	Rural-5 Acre	Single Family Res-Combo
06 130075 RK	R-5	Rural-5 Acre	Single Family Res-Combo

Accessory Dwelling Units

Index # - File Name: 1.0022 - Single Family Dwellings Data\_Snohomish County.pdf

06 132719 RK	R-5	Rural-5 Acre	Single Family Res-Combo
06 125537 RK	R-5	Rural-5 Acre	SFR-Basic
06 126852 RK	R-5	Rural-5 Acre	Single Family Res-Combo
05 122789 RK	R-5	Rural-5 Acre	Single Family Res-Combo
06 133309 RK	R-5	Rural-5 Acre	Single Family Res-Combo
05 127998 RK	R-5	Rural-5 Acre	Single Family Res-Combo
06 124958 RK	R-5	Rural-5 Acre	Single Family Res-Combo
05 128914 MH	R-5	Rural-5 Acre	Double Wide
06 104252 RK	A-10	Agriculture-10 Acre	Single Family Res-Combo
05 129166 MH	R-5	Rural-5 Acre	Double Wide
05 124696 RK	RD	Rural Diversification	Single Family Res-Combo
06 103840 RK	R-5	Rural-5 Acre	Single Family Res-Combo
05 128979 MH	RD	Rural Diversification	Triple Wide
06 130803 RK	F	Forestry	Single Family Res-Combo
06 126022 RK	R-5	Rural-5 Acre	Accessory Apt Detached-Combo
06 129888 RK	R-5	Rural-5 Acre	Single Family Res-Combo
06 126736 RK	R-5	Rural-5 Acre	Single Family Res-Combo
06 129956 RK	R-5	Rural-5 Acre	Single Family Res-Combo
05 121992 RK	R-5	Rural-5 Acre	Single Family Res-Combo
05 117505 RK	R-5	Rural-5 Acre	Single Family Res-Combo
06 125153 RK	R-5	Rural-5 Acre	Single Family Res-Combo
06 101029 RK	R-5	Rural-5 Acre	Single Family Res-Combo
05 116893 RK	R-5	Rural-5 Acre	Single Family Res-Combo
06 125145 RK	R-5	Rural-5 Acre	Single Family Res-Combo
06 129076 RK	R-5	Rural-5 Acre	Single Family Res-Combo
05 127883 RK	R-5	Rural-5 Acre	Single Family Res-Combo
06 126277 MH	R-5	Rural-5 Acre	Double Wide
06 130238 RK	R-5	Rural-5 Acre	Single Family Res-Combo
05 128924 RK	R-5	Rural-5 Acre	SFR-Basic
06 102712 RK	R-5	Rural-5 Acre	Single Family Res-Combo
06 100462 RK	A-10	Agriculture-10 Acre	Single Family Res-Combo
06 132153 RK	R-5	Rural-5 Acre	Single Family Res-Combo
05 116163 RK	R-5	Rural-5 Acre	SFR-Basic
06 125720 RK	RRT-10	Rural Resource Transition-10	Single Family Res-Combo
06 127893 RK	R-5	Rural-5 Acre	Single Family Res-Combo
06 124929 RK	R-5	Rural-5 Acre	Single Family Res-Combo
06 127406 RK	R-5	Rural-5 Acre	Single Family Res-Combo
06 126787 RK	R-5	Rural-5 Acre	Single Family Res-Combo
06 104222 RK	R-5	Rural-5 Acre	Single Family Res-Combo
06 131722 RK	F	Forestry	Single Family Res-Combo
06 127518 MH	R-5	Rural-5 Acre	Double Wide
06 131175 MH	SA-1	Suburban Agriculture-1 Acre	Double Wide
06 129627 RK	CITY	City	Single Family Res-Combo
06 131361 RK	R-5	Rural-5 Acre	Single Family Res-Combo
06 103559 RK	R-5	Rural-5 Acre	Single Family Res-Combo
06 125274 RK	R-5	Rural-5 Acre	Single Family Res-Combo
05 125179 MH	RD	Rural Diversification	Double Wide



Accessory Dwelling Units

Index # - File Name: 1.0022 - Single Family Dwellings Data\_Snohomish County.pdf

05 122013 RK	R-5	Rural-5 Acre	Single Family Res-Combo
06 125272 RK	R-5	Rural-5 Acre	Single Family Res-Combo
04 117107 000 01 RK	R-5	Rural-5 Acre	Single Family Res-Combo
06 129683 RK	R-5	Rural-5 Acre	Accessory Apt Detached-Combo
05 128007 RK	R-5	Rural-5 Acre	Single Family Res-Combo
05 121287 RK	RC	Rural Conservation	Single Family Res-Combo
05 128616 RK	RD	Rural Diversification	Single Family Res-Combo
06 125857 RK	R-5	Rural-5 Acre	Single Family Res-Combo
05 127674 RK	R-5	Rural-5 Acre	Single Family Res-Combo
06 125747 RK	R-5	Rural-5 Acre	SFR-Basic
06 131578 RK	R-5	Rural-5 Acre	SFR-Basic
06 125421 RK	R-5	Rural-5 Acre	Accessory Apt Detached-Combo
06 103348 RK	R-5	Rural-5 Acre	Single Family Res-Combo
05 124836 RK	R-9,600	Residential 9,600 sq. ft.	Single Family Res-Combo
06 101836 RK	R-5	Rural-5 Acre	Single Family Res-Combo
05 122980 RK	R-5	Rural-5 Acre	Single Family Res-Combo
05 122982 RK	R-5	Rural-5 Acre	Single Family Res-Combo
06 131581 RK	R-5	Rural-5 Acre	SFR-Basic
06 126488 RK	R-5	Rural-5 Acre	Single Family Res-Combo
06 128011 RK	R-5	Rural-5 Acre	Single Family Res-Combo
06 127534 RK	R-5	Rural-5 Acre	Single Family Res-Combo
05 125334 RK	F	Forestry	Single Family Res-Combo
06 130880 RK	R-5	Rural-5 Acre	Single Family Res-Combo
06 131088 RK	R-5	Rural-5 Acre	Single Family Res-Combo
06 127273 RK	R-5	Rural-5 Acre	Single Family Res-Combo
06 101354 RK	R-5	Rural-5 Acre	Single Family Res-Combo
06 127040 MH	RD	Rural Diversification	Triple Wide
05 124059 RK	R-5	Rural-5 Acre	Single Family Res-Combo
05 124067 RK	R-5	Rural-5 Acre	Single Family Res-Combo
06 127266 RK	R-5	Rural-5 Acre	Single Family Res-Combo
06 100569 RK	R-5	Rural-5 Acre	Single Family Res-Combo
06 125455 RK	R-5	Rural-5 Acre	Single Family Res-Combo
06 130212 RK	RC	Rural Conservation	Single Family Res-Combo
06 128593 MH	R-5	Rural-5 Acre	Triple Wide
05 125944 RK	R-5	Rural-5 Acre	Single Family Res-Combo
06 127060 RK	R-5	Rural-5 Acre	Single Family Res-Combo
06 130519 RK	R-5	Rural-5 Acre	Single Family Res-Combo
05 128912 RK	R-5	Rural-5 Acre	Single Family Res-Combo
06 127267 RK	R-5	Rural-5 Acre	Single Family Res-Combo
06 103366 RK	R-5	Rural-5 Acre	Single Family Res-Combo
05 129318 RK	R-5	Rural-5 Acre	SFR-Basic
06 133011 RK	F	Forestry	Single Family Res-Combo
06 102295 RK	R-9,600	Residential 9,600 sq. ft.	Single Family Res-Combo
03 110901 000 01 RK	R-5	Rural-5 Acre	Single Family Res-Combo
03 109483 000 01 MH	A-10	Agriculture-10 Acre	Double Wide
06 103779 RK	R-5	Rural-5 Acre	Single Family Res-Combo
06 103411 RK	R-5	Rural-5 Acre	Single Family Res-Combo

Accessory Dwelling Units

Index # - File Name: 1.0022 - Single Family Dwellings Data\_Snohomish County.pdf

06 127013 RK	R-5	Rural-5 Acre	Single Family Res-Combo
06 103291 RK	R-5	Rural-5 Acre	Single Family Res-Combo
06 133773 RK	R-5	Rural-5 Acre	Single Family Res-Combo
06 125161 RK	R-5	Rural-5 Acre	Single Family Res-Combo
06 126361 RK	R-5	Rural-5 Acre	Single Family Res-Combo
05 128849 RK	R-5	Rural-5 Acre	Single Family Res-Combo
06 101341 MH	F	Forestry	Double Wide
06 102847 RK	R-5	Rural-5 Acre	Single Family Res-Combo
06 104133 RK	R-5	Rural-5 Acre	Single Family Res-Combo
05 127282 RK	R-5	Rural-5 Acre	Single Family Res-Combo
06 125467 RK	R-5	Rural-5 Acre	Single Family Res-Combo
04 112247 000 01 RK	R-5	Rural-5 Acre	Single Family Res-Combo
07 104454 RK	A-10	Agriculture-10 Acre	Single Family Res-Combo
06 103780 RK	R-5	Rural-5 Acre	Single Family Res-Combo
07 106099 RK	R-5	Rural-5 Acre	Accessory Apt Detached-Combo
06 133279 RK	F	Forestry	Single Family Res-Combo
07 108401 RK	R-5	Rural-5 Acre	SFR-Basic
07 106898 RK	R-5	Rural-5 Acre	Single Family Res-Combo
07 109723 RK	F	Forestry	Single Family Res-Combo
07 108162 RK	LDMR	Low Density Multiple Reside	Duplex-Combo
07 108476 RK	R-5	Rural-5 Acre	Single Family Res-Combo
07 102863 RK	R-5	Rural-5 Acre	Single Family Res-Combo
07 108618 RK	A-10	Agriculture-10 Acre	Single Family Res-Combo
07 101939 RK	R-5	Rural-5 Acre	Single Family Res-Combo
07 110644 RK	R-5	Rural-5 Acre	Single Family Res-Combo
07 111665 RK	R-9,600	Residential 9,600 sq. ft.	Single Family Res-Combo
07 103058 RK	R-5	Rural-5 Acre	Single Family Res-Combo
06 134963 MH	R-5	Rural-5 Acre	Double Wide
07 104101 RK	R-5	Rural-5 Acre	Single Family Res-Combo
06 129132 RK	R-5	Rural-5 Acre	Single Family Res-Combo
07 100645 RK	R-5	Rural-5 Acre	Single Family Res-Combo
06 136151 RK	R-5	Rural-5 Acre	Single Family Res-Combo
06 135114 RK	R-5	Rural-5 Acre	Single Family Res-Combo
06 135686 RK	R-5	Rural-5 Acre	Single Family Res-Combo
06 134514 RK	R-5	Rural-5 Acre	Single Family Res-Combo
07 100378 RK	R-5	Rural-5 Acre	Single Family Res-Combo
07 104481 RK	R-5	Rural-5 Acre	Single Family Res-Combo
07 109271 RK	R-5	Rural-5 Acre	Single Family Res-Combo
06 136975 RK	A-10	Agriculture-10 Acre	Single Family Res-Combo
06 126383 RK	R-5	Rural-5 Acre	Single Family Res-Combo
07 104674 RK	R-5	Rural-5 Acre	Single Family Res-Combo
05 116059 000 01 RK	R-5	Rural-5 Acre	Single Family Res-Combo
07 109007 RK	R-9,600	Residential 9,600 sq. ft.	Single Family Res-Combo
07 101855 RK	R-5	Rural-5 Acre	Single Family Res-Combo
06 137196 RK	F	Forestry	Single Family Res-Combo
07 102126 RK	RC	Rural Conservation	Single Family Res-Combo
06 126392 RK	R-5	Rural-5 Acre	Single Family Res-Combo

Accessory Dwelling Units

Index # - File Name: 1.0022 - Single Family Dwellings Data\_Snohomish County.pdf

07 112097 RK	RC	Rural Conservation	Single Family Res-Combo
06 136137 RK	R-5	Rural-5 Acre	Single Family Res-Combo
07 101538 RK	R-5	Rural-5 Acre	Single Family Res-Combo
06 103100 RK	R-5	Rural-5 Acre	Single Family Res-Combo
07 105401 RK	RD	Rural Diversification	Single Family Res-Combo
06 129020 RK	RD	Rural Diversification	Single Family Res-Combo
07 112317 RK	R-5	Rural-5 Acre	Single Family Res-Combo
05 116528 MH	R-5	Rural-5 Acre	Double Wide
06 128065 RK	F	Forestry	Single Family Res-Combo
07 106791 RK	F	Forestry	Single Family Res-Combo
07 104532 RK	R-5	Rural-5 Acre	Single Family Res-Combo
05 116133 000 01 RK	R-5	Rural-5 Acre	Single Family Res-Combo
05 117405 000 01 RK	RRT-10	Rural Resource Transition-10	Single Family Res-Combo
07 103787 RK	RRT-10	Rural Resource Transition-10	Single Family Res-Combo
06 128459 RK	R-5	Rural-5 Acre	Single Family Res-Combo
06 126961 RK	R-5	Rural-5 Acre	Single Family Res-Combo
07 100172 RK	R-5	Rural-5 Acre	Single Family Res-Combo
07 112882 RK	R-5	Rural-5 Acre	Single Family Res-Combo
07 109320 RK	R-5	Rural-5 Acre	Single Family Res-Combo
07 112964 RK	R-5	Rural-5 Acre	Single Family Res-Combo
07 102289 RK	R-5	Rural-5 Acre	Single Family Res-Combo
07 106717 RK	R-5	Rural-5 Acre	Single Family Res-Combo
06 131616 RK	RD	Rural Diversification	Single Family Res-Combo
07 103999 RK	R-5	Rural-5 Acre	Single Family Res-Combo
07 100467 RK	R-5	Rural-5 Acre	Single Family Res-Combo
06 134140 MH	A-10	Agriculture-10 Acre	Double Wide
06 135928 RK	R-5	Rural-5 Acre	Single Family Res-Combo
06 133691 MH	R-5	Rural-5 Acre	Double Wide
07 107264 RK	R-5	Rural-5 Acre	Single Family Res-Combo
06 135707 RK	R-5	Rural-5 Acre	Single Family Res-Combo
07 108868 RK	RC	Rural Conservation	Accessory Apt Detached-Combo
07 103995 RK	R-5	Rural-5 Acre	Single Family Res-Combo
05 120195 000 01 MH	R-5	Rural-5 Acre	Single Wide
07 109476 RK	R-5	Rural-5 Acre	Single Family Res-Combo
07 106758 MH	R-5	Rural-5 Acre	Double Wide
05 117119 000 01 MH	R-5	Rural-5 Acre	Double Wide
07 102187 RK	R-5	Rural-5 Acre	Single Family Res-Combo
07 102858 RK	R-5	Rural-5 Acre	Single Family Res-Combo
07 107042 RK	R-5	Rural-5 Acre	Single Family Res-Combo
06 137014 RK	R-5	Rural-5 Acre	Single Family Res-Combo
07 101602 RK	R-5	Rural-5 Acre	Single Family Res-Combo
06 133026 RK	R-5	Rural-5 Acre	Single Family Res-Combo
07 104233 RK	R-5	Rural-5 Acre	SFR-Basic
07 104046 RK	R-5	Rural-5 Acre	Single Family Res-Combo
06 130867 RK	R-5	Rural-5 Acre	Single Family Res-Combo
07 106776 RK	R-5	Rural-5 Acre	Single Family Res-Combo
07 112580 RK	R-5	Rural-5 Acre	Single Family Res-Combo

Accessory Dwelling Units

Index # - File Name: 1.0022 - Single Family Dwellings Data\_Snohomish County.pdf

07 102475 RK	R-5	Rural-5 Acre	Single Family Res-Combo
07 105834 RK	R-5	Rural-5 Acre	Single Family Res-Combo
07 104503 RK	R-5	Rural-5 Acre	Single Family Res-Combo
07 101416 RK	R-5	Rural-5 Acre	Single Family Res-Combo
05 124951 RK	R-5	Rural-5 Acre	Single Family Res-Combo
07 110010 MH	R-5	Rural-5 Acre	Double Wide
07 107506 MH	R-5	Rural-5 Acre	Double Wide
07 103046 RK	R-5	Rural-5 Acre	Single Family Res-Combo
03 109303 000 01 RK	R-5	Rural-5 Acre	Single Family Res-Combo
07 104595 RK	R-5	Rural-5 Acre	Single Family Res-Combo
05 117726 000 01 RK	R-5	Rural-5 Acre	Single Family Res-Combo
05 119597 RK	F : RC	Forestry : Rural Conservation	Single Family Res-Combo
07 101373 RK	R-5	Rural-5 Acre	Single Family Res-Combo
06 133692 RK	R-5	Rural-5 Acre	Single Family Res-Combo
07 105298 RK	R-5	Rural-5 Acre	Single Family Res-Combo
07 112983 MH	R-5	Rural-5 Acre	Double Wide
07 102474 RK	R-5	Rural-5 Acre	Single Family Res-Combo
06 131299 RK	R-5	Rural-5 Acre	Single Family Res-Combo
05 123608 RK	R-5	Rural-5 Acre	Single Family Res-Combo
07 100130 003 00 MH	R-5	Rural-5 Acre	Portable Building
06 137130 MH	R-5	Rural-5 Acre	Triple Wide
06 131995 RK	R-5	Rural-5 Acre	Single Family Res-Combo
07 110689 RK	R-5	Rural-5 Acre	Single Family Res-Combo
07 102202 RK	R-5	Rural-5 Acre	Single Family Res-Combo
07 101007 RK	R-5	Rural-5 Acre	Single Family Res-Combo
07 100117 RK	R-5	Rural-5 Acre	Duplex-Combo
07 100950 MH	R-5	Rural-5 Acre	Triple Wide
06 135718 RK	R-5	Rural-5 Acre	Single Family Res-Combo
06 131683 RK	R-5	Rural-5 Acre	SFR-Basic
07 101871 MH	R-5	Rural-5 Acre	Double Wide
06 127429 MH	R-5	Rural-5 Acre	Double Wide
07 102787 RK	R-5	Rural-5 Acre	Single Family Res-Combo
05 124459 MH	R-5	Rural-5 Acre	Double Wide
07 103875 RK	RRT-10	Rural Resource Transition-1	(SFR-Basic
07 103272 RK	RRT-10	Rural Resource Transition-1	(Single Family Res-Combo
07 106962 RK	RRT-10	Rural Resource Transition-1	(SFR-Basic
07 102477 RK	RRT-10	Rural Resource Transition-1	(Single Family Res-Combo
05 126575 RK	R-5	Rural-5 Acre	Single Family Res-Combo
06 130434 RK	R-5	Rural-5 Acre	Single Family Res-Combo
06 130452 RK	R-5	Rural-5 Acre	Single Family Res-Combo
07 100192 RK	RRT-10	Rural Resource Transition-1	(Single Family Res-Combo
06 136970 RK	R-5	Rural-5 Acre	Single Family Res-Combo
06 135592 RK	R-5	Rural-5 Acre	Single Family Res-Combo
06 131679 RK	R-5	Rural-5 Acre	Single Family Res-Combo
06 131610 RK	R-5	Rural-5 Acre	Single Family Res-Combo
07 107643 RK	R-5	Rural-5 Acre	Single Family Res-Combo
05 128876 RK	R-5	Rural-5 Acre	Single Family Res-Combo

Accessory Dwelling Units

Index # - File Name: 1.0022 - Single Family Dwellings Data\_Snohomish County.pdf

05 128874 RK	R-5	Rural-5 Acre	Single Family Res-Combo
05 121043 RK	R-5	Rural-5 Acre	Single Family Res-Combo
07 105088 RK	RRT-10	Rural Resource Transition-10	Single Family Res-Combo
06 134945 RK	R-5	Rural-5 Acre	Duplex-Combo
07 107672 RK	R-5	Rural-5 Acre	Single Family Res-Combo
07 102310 RK	R-5	Rural-5 Acre	Single Family Res-Combo
07 106348 RK	R-5	Rural-5 Acre	Single Family Res-Combo
05 119809 000 01 RK	R-7,200	Residential 7,200 sq. ft.	Single Family Res-Combo
05 100493 000 01 RK	R-5	Rural-5 Acre	Single Family Res-Combo
07 110038 RK	R-5	Rural-5 Acre	Single Family Res-Combo
07 105752 RK	R-5	Rural-5 Acre	Single Family Res-Combo
07 108399 RK	R-5	Rural-5 Acre	SFR-Basic
06 133714 MH	RRT-10	Rural Resource Transition-10	Triple Wide
06 130460 RK	R-5	Rural-5 Acre	Single Family Res-Combo
07 107965 RK	CITY	City	Single Family Res-Combo
06 137173 RK	CITY	City	Single Family Res-Combo
06 137121 RK	R-5	Rural-5 Acre	SFR-Basic
06 137101 RK	R-5	Rural-5 Acre	SFR-Basic
06 137103 RK	R-5	Rural-5 Acre	SFR-Basic
07 105518 RK	CITY	City	Single Family Res-Combo
06 132839 RK	R-5	Rural-5 Acre	Single Family Res-Combo
07 104616 RK	CITY	City	Duplex-Combo
07 109701 RK	CITY	City	Single Family Res-Combo
07 100180 RK	CITY	City	Single Family Res-Combo
06 132324 RK	R-5	Rural-5 Acre	Single Family Res-Combo
07 100834 RK	R-7,200	Residential 7,200 sq. ft.	Single Family Res-Combo
07 101323 RK	CITY	City	Duplex-Combo
07 100372 RK	R-5	Rural-5 Acre	Single Family Res-Combo
06 134102 RK	CITY	City	Duplex-Combo
07 108987 MH	RRT-10	Rural Resource Transition-10	Double Wide
07 107505 RK	RRT-10	Rural Resource Transition-10	Duplex-Combo
07 103375 RK	R-5	Rural-5 Acre	Single Family Res-Combo
07 110906 RK	R-5	Rural-5 Acre	Single Family Res-Combo
05 122981 000 01 MH	RRT-10	Rural Resource Transition-10	Double Wide
07 111847 MH	RRT-10	Rural Resource Transition-10	Triple Wide
07 100026 RK	R-5	Rural-5 Acre	SFR-Basic
06 129905 MH	R-5	Rural-5 Acre	Double Wide
06 126639 RK	R-5	Rural-5 Acre	Single Family Res-Combo
07 100867 RK	R-5	Rural-5 Acre	Single Family Res-Combo
07 108779 RK	R-7,200	Residential 7,200 sq. ft.	Single Family Res-Combo
07 102272 RK	R-5	Rural-5 Acre	Single Family Res-Combo
06 134837 RK	R-5	Rural-5 Acre	Single Family Res-Combo
06 137000 RK	R-5	Rural-5 Acre	Accessory Apt Detached-Combo
07 110386 RK	R-5	Rural-5 Acre	Single Family Res-Combo
07 108385 RK	R-9,600	Residential 9,600 sq. ft.	Single Family Res-Combo
07 106478 MH	CITY	City	Double Wide
07 104214 RK	R-5	Rural-5 Acre	Single Family Res-Combo

Accessory Dwelling Units

Index # - File Name: 1.0022 - Single Family Dwellings Data\_Snohomish County.pdf

07 108020 RK	R-5	Rural-5 Acre	Single Family Res-Combo
07 110030 RK	R-5	Rural-5 Acre	Single Family Res-Combo
06 135598 RK	R-5	Rural-5 Acre	Single Family Res-Combo
06 137055 RK	R-5	Rural-5 Acre	Single Family Res-Combo
07 100281 RK	R-5	Rural-5 Acre	Single Family Res-Combo
07 100285 RK	R-5	Rural-5 Acre	Single Family Res-Combo
07 101390 RK	R-5	Rural-5 Acre	Single Family Res-Combo
06 134226 RK	R-5	Rural-5 Acre	Single Family Res-Combo
07 100709 RK	R-5	Rural-5 Acre	Single Family Res-Combo
07 102164 RK	R-5	Rural-5 Acre	Single Family Res-Combo
07 103414 RK	R-5	Rural-5 Acre	Single Family Res-Combo
07 103214 MH	R-5	Rural-5 Acre	Triple Wide
07 101933 RK	R-5	Rural-5 Acre	Single Family Res-Combo
07 114317 RK	R-5	Rural-5 Acre	Single Family Res-Combo
07 100943 RK	R-5	Rural-5 Acre	Single Family Res-Combo
07 100883 RK	WFB	Waterfront Beach	Single Family Res-Combo
07 100808 RK	R-7,200	Residential 7,200 sq. ft.	Duplex-Combo
07 109089 RK	R-7,200	Residential 7,200 sq. ft.	Duplex-Basic
07 105854 RK	R-7,200	Residential 7,200 sq. ft.	Duplex-Basic
07 109168 RK	LDMR	Low Density Multiple Reside	Single Family Res-Combo
07 115081 RK	LDMR	Low Density Multiple Reside	Single Family Res-Combo
07 105395 RK	R-5	Rural-5 Acre	Single Family Res-Combo
07 105849 RK	R-7,200	Residential 7,200 sq. ft.	Duplex-Basic
07 105722 RK	R-5	Rural-5 Acre	Single Family Res-Combo
06 134528 RK	R-5	Rural-5 Acre	Single Family Res-Combo
07 103239 RK	R-5	Rural-5 Acre	Single Family Res-Combo
07 103248 RK	R-5	Rural-5 Acre	Single Family Res-Combo
06 130677 RK	R-5	Rural-5 Acre	Single Family Res-Combo
05 121124 000 01 RK	R-5	Rural-5 Acre	Single Family Res-Combo
06 133192 MH	R-5	Rural-5 Acre	Double Wide
06 133674 RK	R-5	Rural-5 Acre	Single Family Res-Combo
07 104590 RK	R-5	Rural-5 Acre	Single Family Res-Combo
07 104486 RK	R-5	Rural-5 Acre	Single Family Res-Combo
06 132972 RK	R-5	Rural-5 Acre	Accessory Apt Detached-Combo
06 133818 RK	R-5	Rural-5 Acre	Single Family Res-Combo
07 110008 RK	R-5	Rural-5 Acre	Single Family Res-Combo
06 136065 MH	R-5	Rural-5 Acre	Triple Wide
07 101646 RK	R-5	Rural-5 Acre	Single Family Res-Combo
07 104529 RK	R-5	Rural-5 Acre	Single Family Res-Combo
04 116975 000 01 RK	F	Forestry	Single Family Res-Combo
07 112814 RK	R-5	Rural-5 Acre	Single Family Res-Combo
05 116249 000 01 RK	R-5	Rural-5 Acre	Single Family Res-Combo
07 101138 RK	R-5	Rural-5 Acre	Single Family Res-Combo
07 111877 RK	R-7,200	Residential 7,200 sq. ft.	Single Family Res-Combo
07 107304 RK	A-10	Agriculture-10 Acre	Single Family Res-Combo
07 111708 RK	R-5	Rural-5 Acre	Single Family Res-Combo
07 109179 RK	R-5	Rural-5 Acre	Accessory Apt Detached-Combo

Accessory Dwelling Units

Index # - File Name: 1.0022 - Single Family Dwellings Data\_Snohomish County.pdf

07 108115 RK	R-5	Rural-5 Acre	Single Family Res-Combo
05 123110 RK	R-5	Rural-5 Acre	Single Family Res-Combo
07 104396 MH	R-5	Rural-5 Acre	Double Wide
07 104925 RK	R-5	Rural-5 Acre	Single Family Res-Combo
06 134000 RK	R-5	Rural-5 Acre	Single Family Res-Combo
07 104612 RK	R-5	Rural-5 Acre	Single Family Res-Combo
05 101879 000 01 MH	R-5	Rural-5 Acre	Double Wide
07 105772 RK	A-10	Agriculture-10 Acre	Single Family Res-Combo
07 101115 RK	A-10	Agriculture-10 Acre	Single Family Res-Combo
07 111425 RK	R-5	Rural-5 Acre	Single Family Res-Combo
07 106760 RK	R-12,500	Residential 12,500 sq. ft.	SFR-Basic
07 106761 RK	R-12,500	Residential 12,500 sq. ft.	Single Family Res-Combo
06 136152 RK	R-12,500	Residential 12,500 sq. ft.	Single Family Res-Combo
07 100129 MH	R-12,500	Residential 12,500 sq. ft.	Double Wide
07 108026 RK	WFB	Waterfront Beach	Single Family Res-Combo
05 123527 000 01 RK	R-8,400	Residential 8,400 sq. ft.	Single Family Res-Combo
07 100750 MH	R-12,500	Residential 12,500 sq. ft.	Double Wide
07 105484 RK	R-5	Rural-5 Acre	Single Family Res-Combo
07 102667 RK	R-5	Rural-5 Acre	Single Family Res-Combo
07 104999 RK	R-8,400	Residential 8,400 sq. ft.	Duplex-Combo
07 106882 RK	R-5	Rural-5 Acre	SFR-Basic
07 103318 RK	R-5	Rural-5 Acre	SFR-Basic
07 102722 RK	F	Forestry	SFR-Basic
07 105390 RK	R-5	Rural-5 Acre	Single Family Res-Combo
07 108905 RK	R-5	Rural-5 Acre	Single Family Res-Combo
07 101161 RK	R-5	Rural-5 Acre	Single Family Res-Combo
07 100427 RK	R-5	Rural-5 Acre	Single Family Res-Combo
07 104584 RK	R-5	Rural-5 Acre	Single Family Res-Combo
07 110007 RK	R-5	Rural-5 Acre	Single Family Res-Combo
06 128272 RK	F	Forestry	Single Family Res-Combo
07 104856 RK	F	Forestry	Single Family Res-Combo
07 109593 RK	F	Forestry	Single Family Res-Combo
07 108332 RK	PRD-20,000(M	Residential 20,000 sq. ft.	Single Family Res-Combo
07 104781 RK	R-5	Rural-5 Acre	Single Family Res-Combo
07 105233 RK	PRD-20,000(M	Residential 20,000 sq. ft.	Single Family Res-Combo
07 105783 RK	PRD-20,000(M	Residential 20,000 sq. ft.	Single Family Res-Combo
07 105249 RK	R-5	Rural-5 Acre	Single Family Res-Combo
06 130409 RK	R-5	Rural-5 Acre	Single Family Res-Combo
07 110730 RK	R-5	Rural-5 Acre	Single Family Res-Combo
05 121628 RK	F	Forestry	Single Family Res-Combo
06 129906 RK	R-5	Rural-5 Acre	Single Family Res-Combo
06 135610 RK	R-5	Rural-5 Acre	Single Family Res-Combo
06 133986 RK	R-5	Rural-5 Acre	Single Family Res-Combo
07 100276 RK	R-5	Rural-5 Acre	Single Family Res-Combo
07 100410 RK	R-5	Rural-5 Acre	Single Family Res-Combo
06 132656 RK	R-5	Rural-5 Acre	Single Family Res-Combo
07 106571 RK	F	Forestry	Single Family Res-Combo

Accessory Dwelling Units

Index # - File Name: 1.0022 - Single Family Dwellings Data\_Snohomish County.pdf

07 104947 RK	F	Forestry	Single Family Res-Combo
07 109279 RK	R-5	Rural-5 Acre	Single Family Res-Combo
07 106835 RK	R-5	Rural-5 Acre	Single Family Res-Combo
07 101091 RK	R-5	Rural-5 Acre	Single Family Res-Combo
07 105299 RK	R-5	Rural-5 Acre	Single Family Res-Combo
06 133985 RK	A-10	Agriculture-10 Acre	Single Family Res-Combo
07 101754 MH	F	Forestry	Double Wide
07 102650 RK	LDMR	Low Density Multiple Reside	Single Family Res-Combo
05 119916 000 01 RK	R-9,600	Residential 9,600 sq. ft.	Accessory Apt Detached-Combo
07 108884 RK	R-5	Rural-5 Acre	Single Family Res-Combo
07 108488 RK	R-5	Rural-5 Acre	Single Family Res-Combo
07 100839 RK	R-9,600	Residential 9,600 sq. ft.	Duplex-Combo
07 107954 RK	F	Forestry	Accessory Apt Detached-Combo
07 102737 RK	R-5	Rural-5 Acre	Single Family Res-Combo
06 132000 RK	R-5	Rural-5 Acre	Single Family Res-Combo
07 110590 RK	F	Forestry	Single Family Res-Combo
07 107357 RK	R-9,600	Residential 9,600 sq. ft.	Single Family Res-Combo
07 109655 RK	R-5	Rural-5 Acre	Single Family Res-Combo
07 108341 RK	R-5	Rural-5 Acre	Single Family Res-Combo
06 126268 RK	F	Forestry	Single Family Res-Combo
06 125265 001 00 RK	F	Forestry	Single Family Res-Combo
06 134106 RK	R-5	Rural-5 Acre	Single Family Res-Combo
07 103878 RK	R-5	Rural-5 Acre	Single Family Res-Combo
07 104936 RK	R-5	Rural-5 Acre	Single Family Res-Combo
07 101136 RK	R-5	Rural-5 Acre	Single Family Res-Combo
07 109554 RK	R-5	Rural-5 Acre	Single Family Res-Combo
07 105259 RK	R-5	Rural-5 Acre	Single Family Res-Combo
07 108486 RK	R-5	Rural-5 Acre	Accessory Apt Detached-Combo
05 116365 000 01 RK	F	Forestry	Single Family Res-Combo
07 106858 RK	R-5	Rural-5 Acre	Accessory Apt Detached-Combo
07 101089 RK	R-5	Rural-5 Acre	Single Family Res-Combo
06 135090 RK	R-5	Rural-5 Acre	SFR-Basic
07 100916 RK	R-5	Rural-5 Acre	Single Family Res-Combo
07 100189 RK	R-5	Rural-5 Acre	Single Family Res-Combo
06 133320 RK	CITY	City	Duplex-Combo
06 134160 RK	R-5	Rural-5 Acre	Single Family Res-Combo
07 105095 RK	F and R	Forestry and Recreation	Single Family Res-Combo
07 107789 RK	R-5	Rural-5 Acre	Single Family Res-Combo
06 125796 RK	F	Forestry	SFR-Basic
07 104547 RK	R-5	Rural-5 Acre	Single Family Res-Combo
07 102635 RK	F	Forestry	Single Family Res-Combo
06 135112 RK	R-5	Rural-5 Acre	Single Family Res-Combo
07 102887 RK	R-5	Rural-5 Acre	Single Family Res-Combo
06 133082 RK	R-5	Rural-5 Acre	Single Family Res-Combo
07 101244 RK	PRD SA-1	Suburban Agriculture-1 Acre	Single Family Res-Combo
06 135648 RK	R-5	Rural-5 Acre	Single Family Res-Combo
06 135647 RK	R-5	Rural-5 Acre	Single Family Res-Combo



Accessory Dwelling Units

Index # - File Name: 1.0022 - Single Family Dwellings Data\_Snohomish County.pdf

07 106111 RK	R-5	Rural-5 Acre	Single Family Res-Combo
06 134132 RK	R-5	Rural-5 Acre	Single Family Res-Combo
05 100891 000 01 RK	PRD-20,000	Residential 20,000 sq. ft.	Single Family Res-Combo
06 128363 RK	R-5	Rural-5 Acre	Single Family Res-Combo
07 100475 RK	R-5	Rural-5 Acre	Single Family Res-Combo
07 106558 RK	R-5	Rural-5 Acre	Single Family Res-Combo
07 114335 MH	MHP	Mobile Home Park	MH Park-Single Wide
06 125539 RK	R-5	Rural-5 Acre	Single Family Res-Combo
07 104594 RK	WFB	Waterfront Beach	Single Family Res-Combo
07 107634 MH	A-10 : IP	Agriculture-10 Acre : Industr	Double Wide
07 105252 RK	R-5	Rural-5 Acre	Single Family Res-Combo
07 105252 001 00 RK	R-5	Rural-5 Acre	Single Family Res-Combo
07 106427 RK	R-5	Rural-5 Acre	Single Family Res-Combo
07 109765 RK	F	Forestry	Single Family Res-Combo
06 128270 RK	R-5	Rural-5 Acre	Single Family Res-Combo
06 129239 RK	R-5	Rural-5 Acre	Single Family Res-Combo
07 105921 RK	R-5	Rural-5 Acre	Single Family Res-Combo
06 131855 RK	R-5	Rural-5 Acre	Single Family Res-Combo
06 131122 MH	A-10	Agriculture-10 Acre	Double Wide
06 134775 RK	R-5	Rural-5 Acre	Single Family Res-Combo
05 126514 RK	R-5	Rural-5 Acre	SFR-Basic
06 134168 RK	R-5	Rural-5 Acre	Single Family Res-Combo
06 134982 RK	R-5	Rural-5 Acre	SFR-Basic
07 109903 RK	F and R	Forestry and Recreation	Accessory Apt Detached-Combo
07 101016 RK	R-5	Rural-5 Acre	Single Family Res-Combo
07 101355 RK	R-5	Rural-5 Acre	Single Family Res-Combo
07 110220 RK	R-5	Rural-5 Acre	Single Family Res-Combo
07 112246 RK	R-5	Rural-5 Acre	Accessory Apt Detached-Combo
07 100829 RK	R-7,200	Residential 7,200 sq. ft.	SFR-Basic
05 117688 000 01 RK	R-5	Rural-5 Acre	Single Family Res-Combo
06 133927 RK	R-5	Rural-5 Acre	Single Family Res-Combo
06 137145 RK	R-7,200	Residential 7,200 sq. ft.	SFR-Basic
06 137066 RK	R-7,200	Residential 7,200 sq. ft.	SFR-Basic
07 103230 RK	R-7,200	Residential 7,200 sq. ft.	SFR-Basic
06 137080 RK	R-7,200	Residential 7,200 sq. ft.	SFR-Basic
06 137146 RK	R-7,200	Residential 7,200 sq. ft.	SFR-Basic
06 137140 RK	R-7,200	Residential 7,200 sq. ft.	SFR-Basic
06 137139 RK	R-7,200	Residential 7,200 sq. ft.	SFR-Basic
06 137144 RK	R-7,200	Residential 7,200 sq. ft.	SFR-Basic
06 137142 RK	R-7,200	Residential 7,200 sq. ft.	SFR-Basic
06 137151 RK	R-7,200	Residential 7,200 sq. ft.	SFR-Basic
06 137082 RK	R-7,200	Residential 7,200 sq. ft.	SFR-Basic
06 137148 RK	R-7,200	Residential 7,200 sq. ft.	SFR-Basic
06 137149 RK	R-7,200	Residential 7,200 sq. ft.	SFR-Basic
06 137083 RK	R-7,200	Residential 7,200 sq. ft.	SFR-Basic
06 137150 RK	R-7,200	Residential 7,200 sq. ft.	SFR-Basic
07 101409 RK	R-9,600(PRD)	Residential 9,600 sq. ft.	SFR-Basic

Accessory Dwelling Units

Index # - File Name: 1.0022 - Single Family Dwellings Data\_Snohomish County.pdf

07 109572 RK	R-5	Rural-5 Acre	Single Family Res-Combo
06 137134 RK	R-7,200	Residential 7,200 sq. ft.	SFR-Basic
07 100275 RK	R-5	Rural-5 Acre	Single Family Res-Combo
07 101894 RK	R-5	Rural-5 Acre	Single Family Res-Combo
07 100328 RK	R-9,600(PRD)	Residential 9,600 sq. ft.	SFR-Basic
07 102088 RK	R-9,600(PRD)	Residential 9,600 sq. ft.	SFR-Basic
07 102089 RK	R-9,600(PRD)	Residential 9,600 sq. ft.	SFR-Basic
07 103021 RK	R-9,600(PRD)	Residential 9,600 sq. ft.	SFR-Basic
07 102090 RK	R-9,600(PRD)	Residential 9,600 sq. ft.	SFR-Basic
07 106147 RK	R-9,600(PRD)	Residential 9,600 sq. ft.	SFR-Basic
07 107418 RK	R-9,600(PRD)	Residential 9,600 sq. ft.	SFR-Basic
07 107172 RK	R-9,600(PRD)	Residential 9,600 sq. ft.	SFR-Basic
07 101408 RK	R-9,600(PRD)	Residential 9,600 sq. ft.	SFR-Basic
07 104907 RK	R-9,600(PRD)	Residential 9,600 sq. ft.	SFR-Basic
07 105495 RK	R-9,600(PRD)	Residential 9,600 sq. ft.	SFR-Basic
07 100327 RK	R-9,600(PRD)	Residential 9,600 sq. ft.	SFR-Basic
07 104000 RK	R-9,600(PRD)	Residential 9,600 sq. ft.	SFR-Basic
07 101499 RK	R-7,200	Residential 7,200 sq. ft.	Single Family Res-Combo
07 103869 RK	PRD-20,000	Residential 20,000 sq. ft.	SFR-Basic
07 103871 RK	PRD-20,000	Residential 20,000 sq. ft.	SFR-Basic
07 103872 RK			SFR-Basic
07 102071 RK	PRD-20,000	Residential 20,000 sq. ft.	Single Family Res-Combo
05 119423 000 01 RK	R-5	Rural-5 Acre	Single Family Res-Combo
07 111134 RK	A-10	Agriculture-10 Acre	Single Family Res-Combo
07 102176 RK	R-7,200	Residential 7,200 sq. ft.	Single Family Res-Combo
06 133122 RK	R-7,200	Residential 7,200 sq. ft.	Single Family Res-Combo
07 101046 RK	R-9,600(PRD)	Residential 9,600 sq. ft.	SFR-Basic
07 101761 RK	R-9,600(PRD)	Residential 9,600 sq. ft.	SFR-Basic
06 134901 RK	R-5	Rural-5 Acre	Single Family Res-Combo
07 102476 RK	R-5	Rural-5 Acre	Single Family Res-Combo
07 109128 RK	R-5	Rural-5 Acre	Single Family Res-Combo
07 103276 RK	R-5	Rural-5 Acre	Single Family Res-Combo
07 102857 RK	R-5	Rural-5 Acre	Single Family Res-Combo
07 107169 RK	R-9,600(PRD)	Residential 9,600 sq. ft.	SFR-Basic
07 107170 RK	R-9,600(PRD)	Residential 9,600 sq. ft.	SFR-Basic
07 103801 RK	R-7,200	Residential 7,200 sq. ft.	Single Family Res-Combo
07 113491 RK	CITY	City	Single Family Res-Combo
07 101643 RK	CITY	City	SFR-Basic
06 134430 RK	RD	Rural Diversification	Single Family Res-Combo
07 107219 RK	R-5	Rural-5 Acre	Single Family Res-Combo
05 120340 000 01 RK	R-5	Rural-5 Acre	Single Family Res-Combo
07 102471 RK	F	Forestry	Single Family Res-Combo
07 101591 RK	R-5	Rural-5 Acre	Single Family Res-Combo
06 133781 RK	R-5	Rural-5 Acre	Single Family Res-Combo
07 114083 RK	R-5	Rural-5 Acre	Single Family Res-Combo
06 128600 RK	R-5	Rural-5 Acre	SFR-Basic
07 102774 RK	RRT-10	Rural Resource Transition-10	Single Family Res-Combo

Accessory Dwelling Units

Index # - File Name: 1.0022 - Single Family Dwellings Data\_Snohomish County.pdf

07 100524 RK	R-7,200(PRD)	Residential 7,200 sq. ft.	SFR-Basic
07 100525 RK	R-7,200(PRD)	Residential 7,200 sq. ft.	SFR-Basic
07 100526 RK	R-7,200(PRD)	Residential 7,200 sq. ft.	SFR-Basic
07 100528 RK	R-7,200(PRD)	Residential 7,200 sq. ft.	SFR-Basic
07 100530 RK	R-7,200(PRD)	Residential 7,200 sq. ft.	SFR-Basic
07 104482 RK	R-7,200(PRD)	Residential 7,200 sq. ft.	SFR-Basic
07 100529 RK	R-7,200(PRD)	Residential 7,200 sq. ft.	SFR-Basic
07 100522 RK	R-7,200(PRD)	Residential 7,200 sq. ft.	SFR-Basic
06 135399 RK	R-7,200(PRD)	Residential 7,200 sq. ft.	SFR-Basic
06 126733 RK	R-5	Rural-5 Acre	Single Family Res-Combo
07 104602 RK	R-7,200(PRD)	Residential 7,200 sq. ft.	SFR-Basic
07 100520 RK	R-7,200(PRD)	Residential 7,200 sq. ft.	SFR-Basic
07 102972 RK	R-7,200(PRD)	Residential 7,200 sq. ft.	SFR-Basic
07 100534 RK	R-7,200(PRD)	Residential 7,200 sq. ft.	SFR-Basic
07 100531 RK	R-7,200(PRD)	Residential 7,200 sq. ft.	SFR-Basic
07 102142 RK	R-7,200(PRD)	Residential 7,200 sq. ft.	SFR-Basic
07 100537 RK	R-7,200(PRD)	Residential 7,200 sq. ft.	SFR-Basic
07 100538 RK	R-7,200(PRD)	Residential 7,200 sq. ft.	SFR-Basic
07 102973 RK	R-7,200(PRD)	Residential 7,200 sq. ft.	SFR-Basic
07 102975 RK	R-7,200(PRD)	Residential 7,200 sq. ft.	SFR-Basic
07 102979 RK	R-7,200(PRD)	Residential 7,200 sq. ft.	SFR-Basic
07 100540 RK	R-7,200(PRD)	Residential 7,200 sq. ft.	SFR-Basic
07 100535 RK	R-7,200(PRD)	Residential 7,200 sq. ft.	SFR-Basic
07 101536 RK	R-7,200	Residential 7,200 sq. ft.	Single Family Res-Combo
07 100826 RK	R-7,200	Residential 7,200 sq. ft.	SFR-Basic
07 106581 RK	R-7,200	Residential 7,200 sq. ft.	Single Family Res-Combo
07 107759 RK	R-7,200	Residential 7,200 sq. ft.	Single Family Res-Combo
06 135276 RK	R-5	Rural-5 Acre	Single Family Res-Combo
06 135095 RK	R-5	Rural-5 Acre	Single Family Res-Combo
07 101919 RK	R-7,200	Residential 7,200 sq. ft.	SFR-Basic
07 104923 RK	R-5	Rural-5 Acre	Single Family Res-Combo
07 104770 RK	R-5	Rural-5 Acre	Single Family Res-Combo
06 137099 RK	R-5	Rural-5 Acre	Single Family Res-Combo
07 109591 RK	R-5	Rural-5 Acre	Single Family Res-Combo
07 105639 RK	R-5	Rural-5 Acre	Single Family Res-Combo
07 110157 RK	R-5	Rural-5 Acre	Single Family Res-Combo
07 105615 RK	R-5	Rural-5 Acre	Single Family Res-Combo
07 105620 RK	R-5	Rural-5 Acre	Single Family Res-Combo
07 105855 RK	R-5	Rural-5 Acre	Single Family Res-Combo
07 104946 RK	R-5	Rural-5 Acre	Single Family Res-Combo
07 100295 RK	MR	Multiple Residential	SFR-Basic
06 133387 RK	R-5	Rural-5 Acre	Single Family Res-Combo
06 135497 RK	MR	Multiple Residential	Single Family Res-Combo
07 101875 RK	R-7,200	Residential 7,200 sq. ft.	SFR-Basic
07 100493 RK	R-7,200	Residential 7,200 sq. ft.	Single Family Res-Combo
07 106623 RK	R-7,200	Residential 7,200 sq. ft.	Single Family Res-Combo
06 137010 RK	RRT-10	Rural Resource Transition-10	Single Family Res-Combo

Accessory Dwelling Units

Index # - File Name: 1.0022 - Single Family Dwellings Data\_Snohomish County.pdf

07 106628 RK	R-7,200	Residential 7,200 sq. ft.	Single Family Res-Combo
07 100687 RK	RRT-10	Rural Resource Transition-10	Single Family Res-Combo
06 134143 RK	RRT-10	Rural Resource Transition-10	Single Family Res-Combo
06 135652 RK	RRT-10	Rural Resource Transition-10	Single Family Res-Combo
06 131868 RK	R-5	Rural-5 Acre	SFR-Basic
06 133451 RK	R-5	Rural-5 Acre	SFR-Basic
06 132484 RK	R-7,200	Residential 7,200 sq. ft.	SFR-Basic
06 135157 RK	CITY	City	SFR-Basic
06 135166 RK	CITY	City	SFR-Basic
07 104123 RK	R-5	Rural-5 Acre	SFR-Basic
06 135163 RK	CITY	City	SFR-Basic
06 135160 RK	CITY	City	SFR-Basic
06 135156 RK	CITY	City	SFR-Basic
07 100772 RK	R-7,200	Residential 7,200 sq. ft.	SFR-Basic
07 100773 RK	R-7,200	Residential 7,200 sq. ft.	SFR-Basic
07 100774 RK	R-7,200	Residential 7,200 sq. ft.	SFR-Basic
07 101594 RK	R-7,200	Residential 7,200 sq. ft.	SFR-Basic
07 102099 RK	R-9,600	Residential 9,600 sq. ft.	SFR-Basic
07 100874 RK	R-5	Rural-5 Acre	SFR-Basic
07 100771 RK	R-7,200	Residential 7,200 sq. ft.	SFR-Basic
07 101593 RK	R-7,200	Residential 7,200 sq. ft.	SFR-Basic
07 101278 RK	R-7,200	Residential 7,200 sq. ft.	SFR-Basic
07 101275 RK	R-7,200	Residential 7,200 sq. ft.	SFR-Basic
07 109920 RK	R-9,600	Residential 9,600 sq. ft.	SFR-Basic
07 101354 RK	R-5	Rural-5 Acre	Single Family Res-Combo
07 100274 RK	R-7,200	Residential 7,200 sq. ft.	SFR-Basic
07 101276 RK	R-7,200	Residential 7,200 sq. ft.	SFR-Basic
07 100470 RK	R-9,600	Residential 9,600 sq. ft.	SFR-Basic
07 101106 RK	R-9,600	Residential 9,600 sq. ft.	SFR-Basic
07 101360 RK	R-9,600	Residential 9,600 sq. ft.	SFR-Basic
07 101322 RK	R-9,600	Residential 9,600 sq. ft.	SFR-Basic
07 110235 RK	R-9,600	Residential 9,600 sq. ft.	SFR-Basic
07 106649 RK	R-9,600	Residential 9,600 sq. ft.	SFR-Basic
07 103430 RK	R-9,600	Residential 9,600 sq. ft.	SFR-Basic
07 113603 RK	R-9,600	Residential 9,600 sq. ft.	SFR-Basic
07 109200 RK	R-9,600	Residential 9,600 sq. ft.	SFR-Basic
07 107266 RK	R-9,600	Residential 9,600 sq. ft.	SFR-Basic
07 113601 RK	R-9,600	Residential 9,600 sq. ft.	SFR-Basic
07 102101 RK	R-9,600	Residential 9,600 sq. ft.	SFR-Basic
07 100440 RK	R-7,200	Residential 7,200 sq. ft.	SFR-Basic
07 109446 RK	R-9,600	Residential 9,600 sq. ft.	SFR-Basic
07 109677 RK	R-9,600	Residential 9,600 sq. ft.	SFR-Basic
07 112602 RK	R-9,600	Residential 9,600 sq. ft.	SFR-Basic
07 112595 RK	R-9,600	Residential 9,600 sq. ft.	SFR-Basic
07 102275 RK	R-9,600	Residential 9,600 sq. ft.	SFR-Basic
07 102276 RK	R-9,600	Residential 9,600 sq. ft.	SFR-Basic
07 110234 RK	R-9,600	Residential 9,600 sq. ft.	SFR-Basic

Accessory Dwelling Units

Index # - File Name: 1.0022 - Single Family Dwellings Data\_Snohomish County.pdf

07 101671 RK	R-7,200	Residential 7,200 sq. ft.	SFR-Basic
07 101672 RK	R-7,200	Residential 7,200 sq. ft.	SFR-Basic
07 110103 RK	R-7,200	Residential 7,200 sq. ft.	SFR-Basic
07 108782 RK	R-7,200	Residential 7,200 sq. ft.	SFR-Basic
07 106025 RK	R-9,600	Residential 9,600 sq. ft.	SFR-Basic
07 101286 RK	R-9,600	Residential 9,600 sq. ft.	SFR-Basic
07 105406 RK	R-9,600	Residential 9,600 sq. ft.	SFR-Basic
07 104239 RK	R-9,600	Residential 9,600 sq. ft.	SFR-Basic
07 102274 RK	R-9,600	Residential 9,600 sq. ft.	SFR-Basic
07 100606 RK	R-7,200	Residential 7,200 sq. ft.	SFR-Basic
07 102995 RK	R-9,600	Residential 9,600 sq. ft.	SFR-Basic
07 106945 RK	R-9,600	Residential 9,600 sq. ft.	SFR-Basic
07 103429 RK	R-9,600	Residential 9,600 sq. ft.	SFR-Basic
07 101287 RK	R-9,600	Residential 9,600 sq. ft.	SFR-Basic
07 108139 RK	R-9,600	Residential 9,600 sq. ft.	SFR-Basic
07 102996 RK	R-9,600	Residential 9,600 sq. ft.	SFR-Basic
07 101923 RK	R-9,600	Residential 9,600 sq. ft.	SFR-Basic
07 109447 RK	R-9,600	Residential 9,600 sq. ft.	SFR-Basic
07 101883 RK	R-9,600	Residential 9,600 sq. ft.	SFR-Basic
07 106327 RK	R-9,600	Residential 9,600 sq. ft.	SFR-Basic
07 101893 RK	R-9,600	Residential 9,600 sq. ft.	SFR-Basic
07 100438 RK	R-7,200	Residential 7,200 sq. ft.	SFR-Basic
07 100439 RK	R-7,200	Residential 7,200 sq. ft.	SFR-Basic
07 101218 RK	R-7,200	Residential 7,200 sq. ft.	SFR-Basic
07 102348 RK	R-7,200	Residential 7,200 sq. ft.	SFR-Basic
07 102776 RK	R-7,200	Residential 7,200 sq. ft.	SFR-Basic
07 106720 RK	R-7,200	Residential 7,200 sq. ft.	SFR-Basic
07 102778 RK	R-7,200	Residential 7,200 sq. ft.	SFR-Basic
07 102059 RK	R-5	Rural-5 Acre	SFR-Basic
07 104726 RK	R-5	Rural-5 Acre	SFR-Basic
07 100964 RK	R-5	Rural-5 Acre	SFR-Basic
07 100966 RK	R-5	Rural-5 Acre	Single Family Res-Combo
07 101436 RK	R-7,200	Residential 7,200 sq. ft.	SFR-Basic
07 102054 RK	R-5	Rural-5 Acre	SFR-Basic
06 136080 RK	R-5	Rural-5 Acre	Single Family Res-Combo
06 136082 RK	R-5	Rural-5 Acre	SFR-Basic
07 100649 RK	R-5	Rural-5 Acre	SFR-Basic
07 100879 RK	R-5	Rural-5 Acre	SFR-Basic
07 100882 RK	R-5	Rural-5 Acre	Single Family Res-Combo
07 100651 RK	R-5	Rural-5 Acre	SFR-Basic
07 102257 RK	R-7,200	Residential 7,200 sq. ft.	SFR-Basic
07 102258 RK	R-7,200	Residential 7,200 sq. ft.	SFR-Basic
07 102259 RK	R-7,200	Residential 7,200 sq. ft.	SFR-Basic
07 102261 RK	R-7,200	Residential 7,200 sq. ft.	SFR-Basic
07 102262 RK	R-7,200	Residential 7,200 sq. ft.	SFR-Basic
07 104034 RK	R-7,200	Residential 7,200 sq. ft.	SFR-Basic
07 101024 RK	R-7,200	Residential 7,200 sq. ft.	SFR-Basic

Accessory Dwelling Units

Index # - File Name: 1.0022 - Single Family Dwellings Data\_Snohomish County.pdf

07 102347 RK	R-7,200	Residential 7,200 sq. ft.	SFR-Basic
07 101023 RK	R-7,200	Residential 7,200 sq. ft.	SFR-Basic
07 102642 RK	R-7,200	Residential 7,200 sq. ft.	SFR-Basic
07 102643 RK	R-7,200	Residential 7,200 sq. ft.	SFR-Basic
07 102260 RK	R-7,200	Residential 7,200 sq. ft.	SFR-Basic
07 102640 RK	R-7,200	Residential 7,200 sq. ft.	Single Family Res-Combo
07 104241 RK	CITY	City	SFR-Basic
07 103188 RK	R-7,200	Residential 7,200 sq. ft.	SFR-Basic
07 103286 RK	R-7,200	Residential 7,200 sq. ft.	SFR-Basic
07 103287 RK	R-7,200	Residential 7,200 sq. ft.	SFR-Basic
07 103861 RK	R-7,200	Residential 7,200 sq. ft.	SFR-Basic
07 103289 RK	R-7,200	Residential 7,200 sq. ft.	SFR-Basic
07 103862 RK	R-7,200	Residential 7,200 sq. ft.	SFR-Basic
07 103291 RK	R-7,200	Residential 7,200 sq. ft.	SFR-Basic
07 103292 RK	R-7,200	Residential 7,200 sq. ft.	SFR-Basic
07 103860 RK	R-7,200	Residential 7,200 sq. ft.	SFR-Basic
07 103285 RK	R-7,200	Residential 7,200 sq. ft.	SFR-Basic
07 112598 RK	CITY	City	SFR-Basic
07 107417 RK	MR	Multiple Residential	SFR-Basic
07 107440 RK	MR	Multiple Residential	SFR-Basic
07 107414 RK	MR	Multiple Residential	SFR-Basic
07 107415 RK	MR	Multiple Residential	SFR-Basic
07 107495 RK	MR	Multiple Residential	SFR-Basic
07 107416 RK	MR	Multiple Residential	SFR-Basic
07 107496 RK	MR	Multiple Residential	SFR-Basic
07 100441 RK	MR	Multiple Residential	SFR-Basic
07 110101 RK	MR	Multiple Residential	SFR-Basic
06 134801 RK	MR	Multiple Residential	SFR-Basic
06 134800 RK	MR	Multiple Residential	SFR-Basic
06 132488 RK	MR	Multiple Residential	SFR-Basic
07 105881 RK	R-5	Rural-5 Acre	Single Family Res-Combo
07 100644 RK	MR	Multiple Residential	Single Family Res-Combo
05 126461 RK	R-5	Rural-5 Acre	Single Family Res-Combo
07 110660 RK	R-9,600	Residential 9,600 sq. ft.	Single Family Res-Combo
07 108007 RK	R-7,200	Residential 7,200 sq. ft.	SFR-Basic
07 106777 RK	R-7,200	Residential 7,200 sq. ft.	SFR-Basic
07 101135 RK	R-7,200	Residential 7,200 sq. ft.	SFR-Basic
07 102039 RK	R-7,200	Residential 7,200 sq. ft.	SFR-Basic
07 100743 RK	R-7,200	Residential 7,200 sq. ft.	SFR-Basic
07 101357 RK	R-7,200	Residential 7,200 sq. ft.	SFR-Basic
07 104229 RK	R-7,200	Residential 7,200 sq. ft.	SFR-Basic
07 100094 RK	R-7,200	Residential 7,200 sq. ft.	SFR-Basic
07 105237 RK	R-7,200	Residential 7,200 sq. ft.	SFR-Basic
07 106021 RK	R-7,200	Residential 7,200 sq. ft.	SFR-Basic
07 100949 RK	R-7,200	Residential 7,200 sq. ft.	SFR-Basic
07 102714 RK	R-7,200	Residential 7,200 sq. ft.	SFR-Basic
07 102068 RK	R-7,200	Residential 7,200 sq. ft.	Single Family Res-Combo

Accessory Dwelling Units

Index # - File Name: 1.0022 - Single Family Dwellings Data\_Snohomish County.pdf

07 102066 RK	R-7,200	Residential 7,200 sq. ft.	Single Family Res-Combo
07 112566 RK	R-5	Rural-5 Acre	SFR-Basic
06 135313 RK	R-5	Rural-5 Acre	SFR-Basic
05 126508 RK	R-5	Rural-5 Acre	SFR-Basic
06 134986 RK	R-5	Rural-5 Acre	SFR-Basic
06 132106 RK	MR	Multiple Residential	SFR-Basic
07 100642 RK	MR	Multiple Residential	Single Family Res-Combo
07 103796 RK	R-7,200	Residential 7,200 sq. ft.	Single Family Res-Combo
06 134170 RK	R-7,200	Residential 7,200 sq. ft.	SFR-Basic
06 134147 RK	R-7,200	Residential 7,200 sq. ft.	SFR-Basic
07 103800 RK	R-7,200	Residential 7,200 sq. ft.	Single Family Res-Combo
06 134084 RK	R-7,200	Residential 7,200 sq. ft.	SFR-Basic
06 134085 RK	R-7,200	Residential 7,200 sq. ft.	SFR-Basic
06 134086 RK	R-7,200	Residential 7,200 sq. ft.	SFR-Basic
06 134087 RK	R-7,200	Residential 7,200 sq. ft.	SFR-Basic
07 102170 RK	R-7,200	Residential 7,200 sq. ft.	SFR-Basic
07 103072 RK	R-7,200	Residential 7,200 sq. ft.	Single Family Res-Combo
07 102169 RK	R-7,200	Residential 7,200 sq. ft.	SFR-Basic
07 103794 RK	R-7,200	Residential 7,200 sq. ft.	Single Family Res-Combo
07 103797 RK	R-7,200	Residential 7,200 sq. ft.	Single Family Res-Combo
07 100402 RK	R-7,200	Residential 7,200 sq. ft.	SFR-Basic
06 135518 RK	R-5	Rural-5 Acre	SFR-Basic
07 100224 RK	R-5	Rural-5 Acre	SFR-Basic
06 135517 RK	R-5	Rural-5 Acre	SFR-Basic
07 102594 RK	R-5	Rural-5 Acre	SFR-Basic
07 102144 RK	R-5	Rural-5 Acre	SFR-Basic
07 102143 RK	R-5	Rural-5 Acre	SFR-Basic
07 102742 RK	R-5	Rural-5 Acre	SFR-Basic
07 102130 RK	A-10	Agriculture-10 Acre	Single Family Res-Combo
07 106178 RK	R-7,200	Residential 7,200 sq. ft.	SFR-Basic
07 105728 RK	MR	Multiple Residential	SFR-Basic
07 105225 RK	MR	Multiple Residential	SFR-Basic
07 104406 RK	MR	Multiple Residential	SFR-Basic
07 108042 RK	MR	Multiple Residential	SFR-Basic
07 104234 RK	MR	Multiple Residential	SFR-Basic
07 111274 RK	R-5	Rural-5 Acre	Single Family Res-Combo
07 111278 RK	R-5	Rural-5 Acre	Single Family Res-Combo
07 105494 RK	R-7,200	Residential 7,200 sq. ft.	Single Family Res-Combo
07 108044 RK	MR	Multiple Residential	Single Family Res-Combo
07 107609 RK	MR	Multiple Residential	SFR-Basic
07 108035 RK	MR	Multiple Residential	SFR-Basic
07 107412 RK	MR	Multiple Residential	SFR-Basic
07 107413 RK	MR	Multiple Residential	SFR-Basic
07 105226 RK	MR	Multiple Residential	SFR-Basic
07 108041 RK	MR	Multiple Residential	SFR-Basic
07 105727 RK	MR	Multiple Residential	SFR-Basic
07 105821 RK	MR	Multiple Residential	SFR-Basic

Accessory Dwelling Units

Index # - File Name: 1.0022 - Single Family Dwellings Data\_Snohomish County.pdf

07 104230 RK	MR	Multiple Residential	SFR-Basic
06 128340 RK	R-5	Rural-5 Acre	Single Family Res-Combo
06 129455 RK	R-5	Rural-5 Acre	Duplex-Combo
06 135115 RK	F	Forestry	Single Family Res-Combo
07 104899 RK	RD	Rural Diversification	Single Family Res-Combo
05 124141 RK	R-5	Rural-5 Acre	SFR-Basic
06 135279 RK	R-5	Rural-5 Acre	Single Family Res-Combo
07 113625 RK	R-5	Rural-5 Acre	Single Family Res-Combo
07 106572 RK	R-5	Rural-5 Acre	SFR-Basic
07 106568 RK	R-5	Rural-5 Acre	Single Family Res-Combo
07 101529 RK	R-5	Rural-5 Acre	Single Family Res-Combo
07 104110 RK	R-5	Rural-5 Acre	Single Family Res-Combo
04 110549 000 01 RK	R-5	Rural-5 Acre	Single Family Res-Combo
06 134383 RK	R-5	Rural-5 Acre	Single Family Res-Combo
05 123425 000 01 RK	R-5	Rural-5 Acre	Single Family Res-Combo
07 104791 RK	R-5	Rural-5 Acre	Single Family Res-Combo
07 106831 RK	R-5	Rural-5 Acre	Single Family Res-Combo
07 106514 RK	R-5	Rural-5 Acre	Single Family Res-Combo
05 100528 000 01 RK	R-5	Rural-5 Acre	Single Family Res-Combo
06 132529 RK	A-10	Agriculture-10 Acre	Single Family Res-Combo
07 100080 RK	R-5	Rural-5 Acre	Single Family Res-Combo
06 135396 MH	R-5	Rural-5 Acre	Double Wide
06 136148 RK	R-9,600	Residential 9,600 sq. ft.	Single Family Res-Combo
07 104144 RK	R-5	Rural-5 Acre	Single Family Res-Combo
07 104272 RK	R-5	Rural-5 Acre	Single Family Res-Combo
06 134818 RK	R-5	Rural-5 Acre	SFR-Basic
05 122462 000 01 RK	R-5	Rural-5 Acre	Single Family Res-Combo
06 128714 RK	RRT-10	Rural Resource Transition-10	Single Family Res-Combo
07 113627 MH	UC	Urban Center	MH Park-Single Wide
06 103593 RK	R-5	Rural-5 Acre	Single Family Res-Combo
07 102967 RK	CITY	City	SFR-Basic
07 102599 RK	CITY	City	SFR-Basic
07 103309 RK	CITY	City	SFR-Basic
07 103353 RK	CITY	City	SFR-Basic
07 102964 RK	CITY	City	SFR-Basic
07 102965 RK	CITY	City	SFR-Basic
07 102966 RK	CITY	City	SFR-Basic
07 104081 RK	A-10	Agriculture-10 Acre	Single Family Res-Combo
06 129822 MH	A-10 : R-5	Agriculture-10 Acre : Rural-5	Double Wide
07 105811 RK	R-5	Rural-5 Acre	Single Family Res-Combo
06 133462 RK	R-5	Rural-5 Acre	Single Family Res-Combo
06 130416 RK	R-5	Rural-5 Acre	Single Family Res-Combo
06 100445 MH	R-5	Rural-5 Acre	Double Wide
06 137172 RK	F	Forestry	Single Family Res-Combo
06 134735 RK	R-5	Rural-5 Acre	Single Family Res-Combo
06 135118 RK	R-5	Rural-5 Acre	Single Family Res-Combo
07 107757 RK	R-5	Rural-5 Acre	SFR-Basic



Accessory Dwelling Units

Index # - File Name: 1.0022 - Single Family Dwellings Data\_Snohomish County.pdf

07 103249 RK	R-5	Rural-5 Acre	SFR-Basic
07 103250 RK	R-5	Rural-5 Acre	SFR-Basic
07 107831 RK	R-5	Rural-5 Acre	SFR-Basic
07 103252 RK	R-5	Rural-5 Acre	SFR-Basic
07 106238 RK	R-7,200	Residential 7,200 sq. ft.	Single Family Res-Combo
07 106233 RK	R-7,200	Residential 7,200 sq. ft.	Single Family Res-Combo
07 106237 RK	R-7,200	Residential 7,200 sq. ft.	Single Family Res-Combo
07 106231 RK	R-7,200	Residential 7,200 sq. ft.	Single Family Res-Combo
07 107289 RK	R-7,200	Residential 7,200 sq. ft.	Single Family Res-Combo
07 107290 RK	R-7,200	Residential 7,200 sq. ft.	Single Family Res-Combo
06 135231 RK	R-5	Rural-5 Acre	Single Family Res-Combo
06 134449 RK	R-5	Rural-5 Acre	Single Family Res-Combo
07 104205 RK	R-7,200	Residential 7,200 sq. ft.	SFR-Basic
07 103806 RK	R-7,200	Residential 7,200 sq. ft.	SFR-Basic
07 104206 RK	R-7,200	Residential 7,200 sq. ft.	SFR-Basic
07 104207 RK	R-7,200	Residential 7,200 sq. ft.	SFR-Basic
07 103807 RK	R-7,200	Residential 7,200 sq. ft.	SFR-Basic
07 104274 RK	R-7,200	Residential 7,200 sq. ft.	SFR-Basic
07 103808 RK	R-7,200	Residential 7,200 sq. ft.	SFR-Basic
07 103809 RK	R-7,200	Residential 7,200 sq. ft.	SFR-Basic
07 104204 RK	R-7,200	Residential 7,200 sq. ft.	SFR-Basic
07 103804 RK	R-7,200	Residential 7,200 sq. ft.	SFR-Basic
07 103805 RK	R-7,200	Residential 7,200 sq. ft.	SFR-Basic
07 105234 RK	R-7,200	Residential 7,200 sq. ft.	SFR-Basic
07 104535 RK	R-7,200	Residential 7,200 sq. ft.	SFR-Basic
07 104536 RK	R-7,200	Residential 7,200 sq. ft.	SFR-Basic
07 104537 RK	R-7,200	Residential 7,200 sq. ft.	SFR-Basic
07 104538 RK	R-7,200	Residential 7,200 sq. ft.	SFR-Basic
07 104539 RK	R-7,200	Residential 7,200 sq. ft.	SFR-Basic
07 104540 RK	R-7,200	Residential 7,200 sq. ft.	SFR-Basic
07 107539 RK	R-7,200	Residential 7,200 sq. ft.	SFR-Basic
07 107541 RK	R-7,200	Residential 7,200 sq. ft.	SFR-Basic
07 107542 RK	R-7,200	Residential 7,200 sq. ft.	SFR-Basic
07 107543 RK	R-7,200	Residential 7,200 sq. ft.	SFR-Basic
07 107545 RK	R-7,200	Residential 7,200 sq. ft.	SFR-Basic
07 107546 RK	R-7,200	Residential 7,200 sq. ft.	SFR-Basic
07 107703 RK	R-7,200	Residential 7,200 sq. ft.	Single Family Res-Combo
07 108018 RK	R-7,200	Residential 7,200 sq. ft.	Single Family Res-Combo
07 109667 RK	R-7,200	Residential 7,200 sq. ft.	Single Family Res-Combo
07 112264 RK	LDMR	Low Density Multiple Reside	SFR-Basic
07 112265 RK	LDMR	Low Density Multiple Reside	SFR-Basic
07 112263 RK	LDMR	Low Density Multiple Reside	SFR-Basic
07 100237 RK	R-5	Rural-5 Acre	SFR-Basic
07 102880 RK	R-5	Rural-5 Acre	Single Family Res-Combo
07 100403 RK	R-5	Rural-5 Acre	SFR-Basic
07 102873 RK	R-5	Rural-5 Acre	SFR-Basic
07 101633 RK	R-5	Rural-5 Acre	Single Family Res-Combo

Accessory Dwelling Units

Index # - File Name: 1.0022 - Single Family Dwellings Data\_Snohomish County.pdf

07 101931 RK	R-5	Rural-5 Acre	Single Family Res-Combo
06 136134 RK	R-5	Rural-5 Acre	SFR-Basic
07 101926 RK	R-5	Rural-5 Acre	Single Family Res-Combo
07 102020 RK	R-5	Rural-5 Acre	Single Family Res-Combo
07 103803 RK	R-7,200	Residential 7,200 sq. ft.	SFR-Basic
06 134052 RK	R-5	Rural-5 Acre	Single Family Res-Combo
07 114435 RK	R-9,600	Residential 9,600 sq. ft.	Single Family Res-Combo
07 107876 RK	R-9,600	Residential 9,600 sq. ft.	SFR-Basic
07 104897 RK	R-9,600	Residential 9,600 sq. ft.	SFR-Basic
07 104934 RK	R-9,600	Residential 9,600 sq. ft.	SFR-Basic
07 107872 RK	R-9,600	Residential 9,600 sq. ft.	SFR-Basic
07 107428 RK	R-9,600	Residential 9,600 sq. ft.	SFR-Basic
07 104890 RK	R-9,600	Residential 9,600 sq. ft.	SFR-Basic
07 114469 RK	R-7,200	Residential 7,200 sq. ft.	SFR-Basic
07 112974 RK	R-7,200	Residential 7,200 sq. ft.	SFR-Basic
07 112600 RK	R-7,200	Residential 7,200 sq. ft.	SFR-Basic
07 107907 RK	R-7,200	Residential 7,200 sq. ft.	SFR-Basic
07 109734 RK	R-7,200	Residential 7,200 sq. ft.	SFR-Basic
07 109680 RK	R-7,200	Residential 7,200 sq. ft.	SFR-Basic
07 112975 RK	R-7,200	Residential 7,200 sq. ft.	SFR-Basic
07 110850 RK	R-7,200	Residential 7,200 sq. ft.	SFR-Basic
07 114470 RK	R-7,200	Residential 7,200 sq. ft.	SFR-Basic
07 104283 RK	R-7,200	Residential 7,200 sq. ft.	SFR-Basic
07 104284 RK	R-7,200	Residential 7,200 sq. ft.	SFR-Basic
07 106509 RK	R-7,200	Residential 7,200 sq. ft.	SFR-Basic
07 106510 RK	R-7,200	Residential 7,200 sq. ft.	SFR-Basic
07 112270 RK	R-7,200	Residential 7,200 sq. ft.	SFR-Basic
07 112271 RK	R-7,200	Residential 7,200 sq. ft.	SFR-Basic
06 135701 RK	A-10	Agriculture-10 Acre	Single Family Res-Combo
07 112272 RK	R-7,200	Residential 7,200 sq. ft.	SFR-Basic
07 100503 RK	CITY	City	SFR-Basic
07 101996 RK	CITY	City	Single Family Res-Combo
07 100507 RK	CITY	City	SFR-Basic
07 106979 RK	R-7,200(PRD)	Residential 7,200 sq. ft.	SFR-Basic
07 106984 RK	R-7,200(PRD)	Residential 7,200 sq. ft.	SFR-Basic
07 107228 RK	R-7,200(PRD)	Residential 7,200 sq. ft.	SFR-Basic
07 107229 RK	R-7,200(PRD)	Residential 7,200 sq. ft.	SFR-Basic
07 108846 RK	R-7,200(PRD)	Residential 7,200 sq. ft.	SFR-Basic
07 104564 RK	R-8,400	Residential 8,400 sq. ft.	Single Family Res-Combo
07 104566 RK	R-8,400	Residential 8,400 sq. ft.	Single Family Res-Combo
06 133201 RK	R-5	Rural-5 Acre	Single Family Res-Combo
07 106236 RK	R-7,200	Residential 7,200 sq. ft.	Single Family Res-Combo
06 135051 RK	A-10	Agriculture-10 Acre	Single Family Res-Combo
07 103029 RK	A-10	Agriculture-10 Acre	Single Family Res-Combo
07 101189 RK	A-10	Agriculture-10 Acre	Single Family Res-Combo
07 101221 RK	R-5	Rural-5 Acre	SFR-Basic
07 110591 RK	R-7,200	Residential 7,200 sq. ft.	SFR-Basic

Accessory Dwelling Units

Index # - File Name: 1.0022 - Single Family Dwellings Data\_Snohomish County.pdf

07 111413 RK	R-7,200	Residential 7,200 sq. ft.	SFR-Basic
07 111414 RK	R-7,200	Residential 7,200 sq. ft.	SFR-Basic
07 107245 RK	R-5	Rural-5 Acre	Single Family Res-Combo
06 136971 RK	R-9,600	Residential 9,600 sq. ft.	Single Family Res-Combo
07 107396 RK	R-5	Rural-5 Acre	Single Family Res-Combo
07 101155 RK	R-5	Rural-5 Acre	Single Family Res-Combo
07 101159 RK	R-5	Rural-5 Acre	Single Family Res-Combo
06 134046 RK	R-5	Rural-5 Acre	Single Family Res-Combo
06 133990 RK	R-5	Rural-5 Acre	Single Family Res-Combo
06 133989 RK	R-5	Rural-5 Acre	Single Family Res-Combo
07 108010 RK	R-7,200(PRD)	Residential 7,200 sq. ft.	SFR-Basic
07 108011 RK	R-7,200(PRD)	Residential 7,200 sq. ft.	SFR-Basic
07 108012 RK	R-7,200(PRD)	Residential 7,200 sq. ft.	SFR-Basic
07 104018 RK	R-5	Rural-5 Acre	Single Family Res-Combo
07 106586 RK	R-5	Rural-5 Acre	Single Family Res-Combo
07 107574 RK	R-5	Rural-5 Acre	Single Family Res-Combo
07 102668 RK	R-7,200(PRD)	Residential 7,200 sq. ft.	SFR-Basic
07 102670 RK	R-7,200(PRD)	Residential 7,200 sq. ft.	SFR-Basic
07 102671 RK	R-7,200(PRD)	Residential 7,200 sq. ft.	SFR-Basic
07 102672 RK	R-7,200(PRD)	Residential 7,200 sq. ft.	SFR-Basic
07 102673 RK	R-7,200(PRD)	Residential 7,200 sq. ft.	SFR-Basic
07 103017 RK	R-7,200(PRD)	Residential 7,200 sq. ft.	SFR-Basic
07 102674 RK	R-7,200(PRD)	Residential 7,200 sq. ft.	SFR-Basic
07 102675 RK	R-7,200(PRD)	Residential 7,200 sq. ft.	SFR-Basic
07 101651 RK	R-7,200(PRD)	Residential 7,200 sq. ft.	SFR-Basic
07 101652 RK	R-7,200(PRD)	Residential 7,200 sq. ft.	SFR-Basic
07 101653 RK	R-7,200(PRD)	Residential 7,200 sq. ft.	SFR-Basic
07 101654 RK	R-7,200(PRD)	Residential 7,200 sq. ft.	SFR-Basic
07 100618 RK	R-7,200(PRD)	Residential 7,200 sq. ft.	SFR-Basic
07 100619 RK	R-7,200(PRD)	Residential 7,200 sq. ft.	SFR-Basic
07 100620 RK	R-7,200(PRD)	Residential 7,200 sq. ft.	SFR-Basic
07 100621 RK	R-7,200(PRD)	Residential 7,200 sq. ft.	SFR-Basic
07 100653 RK	R-7,200(PRD)	Residential 7,200 sq. ft.	SFR-Basic
07 100622 RK	R-7,200(PRD)	Residential 7,200 sq. ft.	SFR-Basic
07 100349 RK	R-7,200(PRD)	Residential 7,200 sq. ft.	SFR-Basic
07 100350 RK	R-7,200(PRD)	Residential 7,200 sq. ft.	SFR-Basic
07 100351 RK	R-7,200(PRD)	Residential 7,200 sq. ft.	SFR-Basic
07 100654 RK	R-7,200(PRD)	Residential 7,200 sq. ft.	SFR-Basic
07 101655 RK	R-7,200(PRD)	Residential 7,200 sq. ft.	SFR-Basic
07 101656 RK	R-7,200(PRD)	Residential 7,200 sq. ft.	SFR-Basic
07 101657 RK	R-7,200(PRD)	Residential 7,200 sq. ft.	SFR-Basic
07 101658 RK	R-7,200(PRD)	Residential 7,200 sq. ft.	SFR-Basic
07 101659 RK	R-7,200(PRD)	Residential 7,200 sq. ft.	SFR-Basic
07 107671 RK	R-7,200(PRD)	Residential 7,200 sq. ft.	SFR-Basic
07 107673 RK	R-7,200(PRD)	Residential 7,200 sq. ft.	SFR-Basic
07 100342 RK	R-7,200(PRD)	Residential 7,200 sq. ft.	SFR-Basic
07 100339 RK	R-7,200(PRD)	Residential 7,200 sq. ft.	SFR-Basic

Accessory Dwelling Units

Index # - File Name: 1.0022 - Single Family Dwellings Data\_Snohomish County.pdf

07 100343 RK	R-7,200(PRD)	Residential 7,200 sq. ft.	SFR-Basic
07 100344 RK	R-7,200(PRD)	Residential 7,200 sq. ft.	SFR-Basic
07 106779 RK	R-5	Rural-5 Acre	Single Family Res-Combo
07 110782 RK	R-5	Rural-5 Acre	Single Family Res-Combo
06 137049 RK	R-7,200	Residential 7,200 sq. ft.	Single Family Res-Combo
06 137044 RK	R-7,200	Residential 7,200 sq. ft.	Single Family Res-Combo
06 137041 RK	R-7,200	Residential 7,200 sq. ft.	Single Family Res-Combo
06 137047 RK	R-7,200	Residential 7,200 sq. ft.	Single Family Res-Combo
06 137043 RK	R-7,200	Residential 7,200 sq. ft.	Single Family Res-Combo
07 110082 RK	R-7,200	Residential 7,200 sq. ft.	Duplex-Combo
07 110072 RK	R-7,200	Residential 7,200 sq. ft.	Duplex-Basic
06 136982 RK	R-5	Rural-5 Acre	SFR-Basic
06 132185 RK	R-5	Rural-5 Acre	Single Family Res-Combo
06 135500 RK	R-5	Rural-5 Acre	Single Family Res-Combo
07 104465 RK	R-5	Rural-5 Acre	Single Family Res-Combo
07 106263 RK	R-5	Rural-5 Acre	SFR-Basic
07 103408 RK	R-5	Rural-5 Acre	SFR-Basic
07 103411 RK	R-5	Rural-5 Acre	SFR-Basic
06 136983 RK	R-5	Rural-5 Acre	SFR-Basic
07 103410 RK	R-5	Rural-5 Acre	SFR-Basic
07 107970 RK	R-5	Rural-5 Acre	SFR-Basic
07 104271 RK	R-7,200	Residential 7,200 sq. ft.	SFR-Basic
07 100724 RK	R-7,200	Residential 7,200 sq. ft.	SFR-Basic
07 102698 RK	R-7,200	Residential 7,200 sq. ft.	SFR-Basic
07 100715 RK	R-7,200 : R-9,6	Residential 7,200 sq. ft. : Res	SFR-Basic
07 102699 RK	R-7,200	Residential 7,200 sq. ft.	SFR-Basic
07 102700 RK	R-7,200	Residential 7,200 sq. ft.	SFR-Basic
07 100714 RK	R-7,200	Residential 7,200 sq. ft.	SFR-Basic
07 102695 RK	R-7,200	Residential 7,200 sq. ft.	SFR-Basic
07 102687 RK	MR	Multiple Residential	SFR-Basic
07 101170 RK	MR	Multiple Residential	SFR-Basic
07 101545 RK	MR	Multiple Residential	SFR-Basic
07 100258 RK	MR	Multiple Residential	SFR-Basic
07 100250 RK	MR	Multiple Residential	SFR-Basic
07 100713 RK	R-7,200	Residential 7,200 sq. ft.	SFR-Basic
07 102696 RK	R-7,200	Residential 7,200 sq. ft.	SFR-Basic
07 107328 RK	R-7,200	Residential 7,200 sq. ft.	SFR-Basic
07 104141 RK	R-7,200	Residential 7,200 sq. ft.	SFR-Basic
07 104270 RK	R-7,200	Residential 7,200 sq. ft.	SFR-Basic
07 104142 RK	R-7,200	Residential 7,200 sq. ft.	SFR-Basic
07 104143 RK	R-7,200	Residential 7,200 sq. ft.	SFR-Basic
07 102697 RK	R-7,200	Residential 7,200 sq. ft.	SFR-Basic
07 101553 RK	R-7,200	Residential 7,200 sq. ft.	SFR-Basic
07 100723 RK	R-7,200	Residential 7,200 sq. ft.	SFR-Basic
07 101554 RK	R-7,200	Residential 7,200 sq. ft.	SFR-Basic
07 101560 RK	R-7,200	Residential 7,200 sq. ft.	SFR-Basic
07 101555 RK	R-7,200	Residential 7,200 sq. ft.	SFR-Basic

Accessory Dwelling Units

Index # - File Name: 1.0022 - Single Family Dwellings Data\_Snohomish County.pdf

07 101555 001 00 RK	R-7,200	Residential 7,200 sq. ft.	Single Family Res-Combo
07 101556 RK	R-7,200	Residential 7,200 sq. ft.	SFR-Basic
07 101557 RK	R-7,200	Residential 7,200 sq. ft.	SFR-Basic
07 101561 RK	MR	Multiple Residential	SFR-Basic
07 107310 RK	MR	Multiple Residential	SFR-Basic
07 102691 RK	MR	Multiple Residential	SFR-Basic
07 107311 RK	MR	Multiple Residential	SFR-Basic
07 107312 RK	MR	Multiple Residential	SFR-Basic
07 104127 RK	MR	Multiple Residential	SFR-Basic
07 106081 RK	MR	Multiple Residential	SFR-Basic
07 104128 RK	MR	Multiple Residential	SFR-Basic
07 100265 RK	MR	Multiple Residential	SFR-Basic
07 100251 RK	MR	Multiple Residential	SFR-Basic
07 104129 RK	MR	Multiple Residential	SFR-Basic
07 104130 RK	MR	Multiple Residential	SFR-Basic
07 104269 RK	MR	Multiple Residential	SFR-Basic
07 104131 RK	MR	Multiple Residential	SFR-Basic
07 100254 RK	MR	Multiple Residential	SFR-Basic
07 100257 RK	MR	Multiple Residential	SFR-Basic
07 102692 RK	MR	Multiple Residential	SFR-Basic
07 102693 RK	MR	Multiple Residential	SFR-Basic
07 107313 RK	MR	Multiple Residential	SFR-Basic
07 107314 RK	MR	Multiple Residential	SFR-Basic
07 106082 RK	MR	Multiple Residential	SFR-Basic
07 107316 RK	MR	Multiple Residential	SFR-Basic
07 102694 RK	MR	Multiple Residential	SFR-Basic
07 104132 RK	MR	Multiple Residential	SFR-Basic
07 101546 RK	MR	Multiple Residential	SFR-Basic
07 101547 RK	MR	Multiple Residential	SFR-Basic
07 100266 RK	MR	Multiple Residential	SFR-Basic
07 100248 RK	MR	Multiple Residential	SFR-Basic
07 101558 RK	MR	Multiple Residential	SFR-Basic
07 101544 RK	MR	Multiple Residential	SFR-Basic
07 100249 RK	MR	Multiple Residential	SFR-Basic
07 100262 RK	MR	Multiple Residential	SFR-Basic
07 100263 RK	MR	Multiple Residential	SFR-Basic
07 102644 RK	R-5	Rural-5 Acre	Single Family Res-Combo
07 100242 RK	MR	Multiple Residential	SFR-Basic
07 100245 RK	MR	Multiple Residential	SFR-Basic
07 100247 RK	MR	Multiple Residential	SFR-Basic
07 100166 RK	R-5	Rural-5 Acre	Single Family Res-Combo
07 102785 RK	R-7,200(PRD)	Residential 7,200 sq. ft.	SFR-Basic
07 101955 RK	F	Forestry	Single Family Res-Combo
07 102626 RK	R-5	Rural-5 Acre	SFR-Basic
07 102704 RK	R-5	Rural-5 Acre	SFR-Basic
06 131685 RK	R-5	Rural-5 Acre	Single Family Res-Combo
07 102800 RK	R-9,600	Residential 9,600 sq. ft.	Single Family Res-Combo

Accessory Dwelling Units

Index # - File Name: 1.0022 - Single Family Dwellings Data\_Snohomish County.pdf

07 101944 RK	R-9,600	Residential 9,600 sq. ft.	SFR-Basic
06 135522 MH	R-12,500	Residential 12,500 sq. ft.	Double Wide
07 102172 RK	R-9,600	Residential 9,600 sq. ft.	SFR-Basic
07 101127 RK	R-9,600	Residential 9,600 sq. ft.	SFR-Basic
07 100190 RK	R-9,600	Residential 9,600 sq. ft.	Single Family Res-Combo
07 107694 RK	R-7,200(PRD)	Residential 7,200 sq. ft.	SFR-Basic
07 101179 RK	R-9,600	Residential 9,600 sq. ft.	Single Family Res-Combo
07 104894 RK	R-9,600	Residential 9,600 sq. ft.	SFR-Basic
07 106078 RK	MR	Multiple Residential	SFR-Basic
07 106079 RK	MR	Multiple Residential	SFR-Basic
07 106080 RK	MR	Multiple Residential	SFR-Basic
07 107315 RK	MR	Multiple Residential	SFR-Basic
07 107317 RK	MR	Multiple Residential	SFR-Basic
07 106083 RK	MR	Multiple Residential	SFR-Basic
07 107318 RK	MR	Multiple Residential	SFR-Basic
07 107319 RK	MR	Multiple Residential	SFR-Basic
07 102685 RK	MR	Multiple Residential	SFR-Basic
06 131783 RK	R-5	Rural-5 Acre	Single Family Res-Combo
07 110608 RK	R-5	Rural-5 Acre	SFR-Basic
07 102586 RK	R-5	Rural-5 Acre	SFR-Basic
07 102493 RK	R-5	Rural-5 Acre	Single Family Res-Combo
07 100240 RK	R-5	Rural-5 Acre	SFR-Basic
07 103356 RK	CITY	City	SFR-Basic
07 107334 RK	R-5	Rural-5 Acre	Single Family Res-Combo
07 106975 RK	R-5	Rural-5 Acre	Single Family Res-Combo
07 105420 RK	R-5	Rural-5 Acre	SFR-Basic
07 110024 RK	MR	Multiple Residential	SFR-Basic
07 112147 RK	MR	Multiple Residential	SFR-Basic
07 108997 RK	MR	Multiple Residential	SFR-Basic
07 106997 RK	MR	Multiple Residential	SFR-Basic
07 106991 RK	MR	Multiple Residential	SFR-Basic
07 108492 RK	MR	Multiple Residential	SFR-Basic
07 108493 RK	MR	Multiple Residential	SFR-Basic
07 106403 RK	MR	Multiple Residential	SFR-Basic
07 106994 RK	MR	Multiple Residential	SFR-Basic
07 106402 RK	MR	Multiple Residential	SFR-Basic
07 106977 RK	MR	Multiple Residential	SFR-Basic
06 135687 RK	R-5	Rural-5 Acre	Single Family Res-Combo
07 108993 RK	MR	Multiple Residential	SFR-Basic
07 108992 RK	MR	Multiple Residential	SFR-Basic
07 110997 RK	MR	Multiple Residential	SFR-Basic
07 110998 RK	MR	Multiple Residential	SFR-Basic
07 114669 RK	MR	Multiple Residential	SFR-Basic
07 109353 RK	MR	Multiple Residential	SFR-Basic
07 109351 RK	MR	Multiple Residential	SFR-Basic
07 110028 RK	MR	Multiple Residential	SFR-Basic
07 103358 RK	CITY	City	SFR-Basic

Accessory Dwelling Units

Index # - File Name: 1.0022 - Single Family Dwellings Data\_Snohomish County.pdf

07 103359 RK	CITY	City	SFR-Basic
07 103360 RK	CITY	City	SFR-Basic
07 103361 RK	CITY	City	SFR-Basic
07 103362 RK	CITY	City	SFR-Basic
07 103364 RK	CITY	City	SFR-Basic
07 103357 RK	CITY	City	SFR-Basic
07 106912 RK	CITY	City	SFR-Basic
07 114670 RK	MR	Multiple Residential	SFR-Basic
07 112149 RK	MR	Multiple Residential	SFR-Basic
07 107706 RK	CITY	City	SFR-Basic
07 106914 RK	CITY	City	SFR-Basic
07 106916 RK	CITY	City	SFR-Basic
07 106921 RK	CITY	City	SFR-Basic
07 105504 RK	CITY	City	SFR-Basic
07 105505 RK	CITY	City	SFR-Basic
07 105506 RK	CITY	City	SFR-Basic
07 105507 RK	CITY	City	SFR-Basic
07 105508 RK	CITY	City	SFR-Basic
07 105516 RK	CITY	City	SFR-Basic
07 105210 RK	CITY	City	SFR-Basic
07 105208 RK	CITY	City	SFR-Basic
07 105510 RK	CITY	City	SFR-Basic
07 105511 RK	CITY	City	SFR-Basic
07 105512 RK	CITY	City	SFR-Basic
07 105513 RK	CITY	City	SFR-Basic
07 105669 RK	CITY	City	SFR-Basic
07 105670 RK	CITY	City	SFR-Basic
07 105671 RK	CITY	City	SFR-Basic
07 104979 RK	CITY	City	SFR-Basic
07 103365 RK	CITY	City	SFR-Basic
07 103366 RK	CITY	City	SFR-Basic
07 103367 RK	CITY	City	SFR-Basic
07 103368 RK	CITY	City	SFR-Basic
07 107470 RK	R-7,200(PRD)	Residential 7,200 sq. ft.	SFR-Basic
07 107472 RK	R-7,200(PRD)	Residential 7,200 sq. ft.	SFR-Basic
07 107473 RK	R-7,200(PRD)	Residential 7,200 sq. ft.	SFR-Basic
07 107447 RK	R-7,200(PRD)	Residential 7,200 sq. ft.	SFR-Basic
07 107448 RK	R-7,200(PRD)	Residential 7,200 sq. ft.	SFR-Basic
07 107449 RK	R-7,200(PRD)	Residential 7,200 sq. ft.	SFR-Basic
07 107450 RK	R-7,200(PRD)	Residential 7,200 sq. ft.	SFR-Basic
07 107451 RK	R-7,200(PRD)	Residential 7,200 sq. ft.	SFR-Basic
07 107452 RK	R-7,200(PRD)	Residential 7,200 sq. ft.	SFR-Basic
07 107453 RK	R-7,200(PRD)	Residential 7,200 sq. ft.	SFR-Basic
07 107454 RK	R-7,200(PRD)	Residential 7,200 sq. ft.	SFR-Basic
07 107455 RK	R-7,200(PRD)	Residential 7,200 sq. ft.	SFR-Basic
07 107456 RK	R-7,200(PRD)	Residential 7,200 sq. ft.	SFR-Basic
07 107457 RK	R-7,200(PRD)	Residential 7,200 sq. ft.	SFR-Basic

Accessory Dwelling Units

Index # - File Name: 1.0022 - Single Family Dwellings Data\_Snohomish County.pdf

07 107458 RK	R-7,200(PRD)	Residential 7,200 sq. ft.	SFR-Basic
07 107459 RK	R-7,200(PRD)	Residential 7,200 sq. ft.	SFR-Basic
07 107460 RK	R-7,200(PRD)	Residential 7,200 sq. ft.	SFR-Basic
07 107461 RK	R-7,200(PRD)	Residential 7,200 sq. ft.	SFR-Basic
07 107462 RK	R-7,200(PRD)	Residential 7,200 sq. ft.	SFR-Basic
07 107463 RK	R-7,200(PRD)	Residential 7,200 sq. ft.	SFR-Basic
07 107464 RK	R-7,200(PRD)	Residential 7,200 sq. ft.	SFR-Basic
07 107465 RK	R-7,200(PRD)	Residential 7,200 sq. ft.	SFR-Basic
07 107466 RK	R-7,200(PRD)	Residential 7,200 sq. ft.	SFR-Basic
07 107467 RK	R-7,200(PRD)	Residential 7,200 sq. ft.	SFR-Basic
07 107468 RK	R-7,200(PRD)	Residential 7,200 sq. ft.	SFR-Basic
07 107469 RK	R-7,200(PRD)	Residential 7,200 sq. ft.	SFR-Basic
07 106928 RK	CITY	City	SFR-Basic
06 135970 RK	R-5	Rural-5 Acre	Single Family Res-Combo
07 107836 RK	R-7,200	Residential 7,200 sq. ft.	SFR-Basic
07 107841 RK	R-7,200	Residential 7,200 sq. ft.	SFR-Basic
07 107844 RK	R-7,200	Residential 7,200 sq. ft.	SFR-Basic
07 107768 RK	R-7,200	Residential 7,200 sq. ft.	SFR-Basic
07 107848 RK	R-7,200	Residential 7,200 sq. ft.	SFR-Basic
07 107849 RK	R-7,200	Residential 7,200 sq. ft.	SFR-Basic
07 107850 RK	R-7,200	Residential 7,200 sq. ft.	SFR-Basic
07 108085 RK	R-5	Rural-5 Acre	Single Family Res-Combo
07 101417 RK	R-5	Rural-5 Acre	Single Family Res-Combo
07 103833 RK	R-5	Rural-5 Acre	Single Family Res-Combo
07 110099 RK	R-5	Rural-5 Acre	Single Family Res-Combo
07 100873 RK	R-5	Rural-5 Acre	Single Family Res-Combo
07 110100 RK	R-5	Rural-5 Acre	Single Family Res-Combo
07 109580 RK	R-5	Rural-5 Acre	Single Family Res-Combo
07 103834 RK	R-5	Rural-5 Acre	Single Family Res-Combo
07 101108 RK	R-5	Rural-5 Acre	Single Family Res-Combo
07 101564 RK	R-5	Rural-5 Acre	Single Family Res-Combo
07 102634 RK	R-5	Rural-5 Acre	Single Family Res-Combo
07 100170 RK	R-5	Rural-5 Acre	Single Family Res-Combo
07 109190 RK	R-5	Rural-5 Acre	Single Family Res-Combo
07 100504 RK	R-5	Rural-5 Acre	Single Family Res-Combo
07 100751 RK	R-5	Rural-5 Acre	Single Family Res-Combo
07 109310 RK	R-5	Rural-5 Acre	Single Family Res-Combo
07 102321 RK	R-5	Rural-5 Acre	Single Family Res-Combo
07 101663 RK	R-7,200	Residential 7,200 sq. ft.	Single Family Res-Combo
07 101903 RK	R-7,200	Residential 7,200 sq. ft.	SFR-Basic
06 132151 RK	R-7,200	Residential 7,200 sq. ft.	Single Family Res-Combo
07 101904 RK	R-7,200	Residential 7,200 sq. ft.	SFR-Basic
07 104927 RK	R-5	Rural-5 Acre	Single Family Res-Combo
07 104409 RK	R-5	Rural-5 Acre	Single Family Res-Combo
07 104433 RK	R-5	Rural-5 Acre	Single Family Res-Combo
07 104441 RK	R-5	Rural-5 Acre	Single Family Res-Combo
07 104437 RK	R-5	Rural-5 Acre	Single Family Res-Combo



Accessory Dwelling Units

Index # - File Name: 1.0022 - Single Family Dwellings Data\_Snohomish County.pdf

07 104436 RK	R-5	Rural-5 Acre	Single Family Res-Combo
07 104435 RK	R-5	Rural-5 Acre	Single Family Res-Combo
07 107775 RK	R-5	Rural-5 Acre	Single Family Res-Combo
07 103781 RK	R-5	Rural-5 Acre	SFR-Basic
07 104443 RK	R-5	Rural-5 Acre	Single Family Res-Combo
07 104444 RK	R-5	Rural-5 Acre	Single Family Res-Combo
07 103790 RK	R-5	Rural-5 Acre	Single Family Res-Combo
07 100156 RK	RD	Rural Diversification	Single Family Res-Combo
07 102436 RK	R-5	Rural-5 Acre	Single Family Res-Combo
06 127970 RK	R-5	Rural-5 Acre	Single Family Res-Combo
07 104729 RK	R-7,200(PRD)	Residential 7,200 sq. ft.	SFR-Basic
07 105272 RK	R-7,200(PRD)	Residential 7,200 sq. ft.	SFR-Basic
07 104731 RK	R-7,200(PRD)	Residential 7,200 sq. ft.	SFR-Basic
07 107407 RK	R-7,200(PRD)	Residential 7,200 sq. ft.	SFR-Basic
07 106319 RK	R-7,200(PRD)	Residential 7,200 sq. ft.	SFR-Basic
07 110774 RK	R-7,200(PRD)	Residential 7,200 sq. ft.	SFR-Basic
07 110773 RK	R-7,200(PRD)	Residential 7,200 sq. ft.	SFR-Basic
07 112808 RK	R-7,200(PRD)	Residential 7,200 sq. ft.	SFR-Basic
07 100408 RK	R-5	Rural-5 Acre	Single Family Res-Combo
07 104845 RK	R-5	Rural-5 Acre	SFR-Basic
07 107476 RK	R-7,200(PRD)	Residential 7,200 sq. ft.	SFR-Basic
07 107488 RK	R-7,200(PRD)	Residential 7,200 sq. ft.	SFR-Basic
07 106316 RK	R-7,200(PRD)	Residential 7,200 sq. ft.	SFR-Basic
07 104732 RK	R-7,200(PRD)	Residential 7,200 sq. ft.	SFR-Basic
07 105273 RK	R-7,200(PRD)	Residential 7,200 sq. ft.	SFR-Basic
07 104730 RK	R-7,200(PRD)	Residential 7,200 sq. ft.	SFR-Basic
07 106493 RK	R-7,200(PRD)	Residential 7,200 sq. ft.	SFR-Basic
07 110950 RK	R-7,200	Residential 7,200 sq. ft.	SFR-Basic
07 107012 RK	R-7,200	Residential 7,200 sq. ft.	SFR-Basic
07 100683 RK	R-5	Rural-5 Acre	Single Family Res-Combo
07 104071 RK	R-5	Rural-5 Acre	Single Family Res-Combo
07 100749 RK	R-5	Rural-5 Acre	Single Family Res-Combo
07 100634 RK	R-9,600	Residential 9,600 sq. ft.	SFR-Basic
07 108327 RK	R-5	Rural-5 Acre	Single Family Res-Combo
07 105805 RK	R-5	Rural-5 Acre	SFR-Basic
07 105804 RK	R-5	Rural-5 Acre	SFR-Basic
07 110201 RK	R-5	Rural-5 Acre	SFR-Basic
07 105807 RK	R-7,200	Residential 7,200 sq. ft.	Single Family Res-Combo
07 105292 RK	R-5	Rural-5 Acre	Single Family Res-Combo
07 104200 RK	R-5	Rural-5 Acre	Single Family Res-Combo
07 101126 RK	LDMR	Low Density Multiple Reside	Single Family Res-Combo
07 101148 RK	R-5	Rural-5 Acre	Single Family Res-Combo
07 107192 RK	R-7,200	Residential 7,200 sq. ft.	SFR-Basic
07 107193 RK	R-7,200	Residential 7,200 sq. ft.	SFR-Basic
07 103422 RK	R-7,200	Residential 7,200 sq. ft.	SFR-Basic
07 103415 RK	R-7,200	Residential 7,200 sq. ft.	SFR-Basic
07 107726 RK	R-7,200	Residential 7,200 sq. ft.	SFR-Basic

Accessory Dwelling Units

Index # - File Name: 1.0022 - Single Family Dwellings Data\_Snohomish County.pdf

07 107796 RK	R-7,200	Residential 7,200 sq. ft.	SFR-Basic
07 103416 RK	R-7,200	Residential 7,200 sq. ft.	SFR-Basic
07 103417 RK	R-7,200	Residential 7,200 sq. ft.	SFR-Basic
07 103418 RK	R-7,200	Residential 7,200 sq. ft.	SFR-Basic
07 103419 RK	R-7,200	Residential 7,200 sq. ft.	SFR-Basic
07 107191 RK	R-7,200	Residential 7,200 sq. ft.	SFR-Basic
07 101459 RK	F	Forestry	Single Family Res-Combo
07 106999 MH	RRT-10	Rural Resource Transition-10	Triple Wide
07 107366 RK	R-5	Rural-5 Acre	Single Family Res-Combo
07 101194 RK	R-5	Rural-5 Acre	Single Family Res-Combo
07 102928 RK	R-7,200(PRD)	Residential 7,200 sq. ft.	SFR-Basic
07 102929 RK	R-7,200(PRD)	Residential 7,200 sq. ft.	SFR-Basic
07 102931 RK	R-7,200(PRD)	Residential 7,200 sq. ft.	SFR-Basic
07 107190 RK	R-7,200	Residential 7,200 sq. ft.	SFR-Basic
07 104255 RK	R-5	Rural-5 Acre	Single Family Res-Combo
07 104258 RK	R-5	Rural-5 Acre	Single Family Res-Combo
06 135728 RK	R-5	Rural-5 Acre	SFR-Basic
07 104289 RK	R-5	Rural-5 Acre	Single Family Res-Combo
07 107102 RK	R-5	Rural-5 Acre	Single Family Res-Combo
07 104589 RK	R-5	Rural-5 Acre	Single Family Res-Combo
07 104593 RK	R-5	Rural-5 Acre	Single Family Res-Combo
07 102334 RK	RD	Rural Diversification	Single Family Res-Combo
07 104941 RK	MR	Multiple Residential	SFR-Basic
07 114107 RK	MR	Multiple Residential	Single Family Res-Combo
07 107982 RK	MR	Multiple Residential	SFR-Basic
07 107977 RK	MR	Multiple Residential	SFR-Basic
07 107890 RK	MR	Multiple Residential	SFR-Basic
07 107984 RK	MR	Multiple Residential	SFR-Basic
07 107978 RK	MR	Multiple Residential	SFR-Basic
07 107979 RK	MR	Multiple Residential	SFR-Basic
07 107892 RK	MR	Multiple Residential	SFR-Basic
07 106713 RK	MR	Multiple Residential	SFR-Basic
07 107980 RK	MR	Multiple Residential	SFR-Basic
07 105812 RK	MR	Multiple Residential	SFR-Basic
07 104943 RK	MR	Multiple Residential	SFR-Basic
07 104944 RK	MR	Multiple Residential	SFR-Basic
07 107991 RK	MR	Multiple Residential	SFR-Basic
07 102100 RK	R-5	Rural-5 Acre	SFR-Basic
07 102181 RK	R-5	Rural-5 Acre	Single Family Res-Combo
07 107995 RK	MR	Multiple Residential	SFR-Basic
07 105813 RK	MR	Multiple Residential	SFR-Basic
07 109092 RK	CITY	City	SFR-Basic
07 102438 RK	MR	Multiple Residential	Single Family Res-Combo
07 112219 RK	CITY	City	Single Family Res-Combo
07 112221 RK	CITY	City	Single Family Res-Combo
07 106158 RK	CITY	City	SFR-Basic
07 104792 RK	CITY	City	SFR-Basic

Accessory Dwelling Units

Index # - File Name: 1.0022 - Single Family Dwellings Data\_Snohomish County.pdf

07 103754 RK	CITY	City	SFR-Basic
07 102337 RK	CITY	City	SFR-Basic
07 102339 RK	CITY	City	SFR-Basic
07 103756 RK	CITY	City	SFR-Basic
07 107411 RK	CITY	City	SFR-Basic
07 102981 RK	R-7,200	Residential 7,200 sq. ft.	SFR-Basic
07 102982 RK	R-7,200	Residential 7,200 sq. ft.	SFR-Basic
07 102983 RK	R-7,200	Residential 7,200 sq. ft.	SFR-Basic
07 102984 RK	R-7,200	Residential 7,200 sq. ft.	SFR-Basic
07 102985 RK	R-7,200	Residential 7,200 sq. ft.	SFR-Basic
07 102986 RK	R-7,200	Residential 7,200 sq. ft.	SFR-Basic
07 102987 RK	R-7,200	Residential 7,200 sq. ft.	SFR-Basic
07 102988 RK	R-7,200	Residential 7,200 sq. ft.	SFR-Basic
07 102738 RK	R-5	Rural-5 Acre	Single Family Res-Combo
07 109235 RK	R-5	Rural-5 Acre	Single Family Res-Combo
07 102792 RK	R-5	Rural-5 Acre	SFR-Basic
07 108555 RK	R-5	Rural-5 Acre	Single Family Res-Combo
07 107905 RK	CITY	City	SFR-Basic
07 107536 RK	CITY	City	SFR-Basic
07 107603 RK	CITY	City	SFR-Basic
07 107602 RK	CITY	City	SFR-Basic
07 107534 RK	CITY	City	SFR-Basic
07 107804 RK	R-5	Rural-5 Acre	SFR-Basic
07 107806 RK	R-5	Rural-5 Acre	SFR-Basic
07 107821 RK	R-5	Rural-5 Acre	SFR-Basic
07 112549 RK	R-5	Rural-5 Acre	Single Family Res-Combo
07 111375 RK	R-5	Rural-5 Acre	Single Family Res-Combo
07 104736 RK	R-5	Rural-5 Acre	Single Family Res-Combo
07 104768 RK	R-5	Rural-5 Acre	Single Family Res-Combo
07 104767 RK	R-5	Rural-5 Acre	Single Family Res-Combo
07 102173 RK	R-9,600	Residential 9,600 sq. ft.	Single Family Res-Combo
07 104220 RK	R-9,600	Residential 9,600 sq. ft.	SFR-Basic
07 107009 RK	R-9,600	Residential 9,600 sq. ft.	Single Family Res-Combo
07 110371 RK	R-5	Rural-5 Acre	Single Family Res-Combo
07 104733 RK	R-5	Rural-5 Acre	Single Family Res-Combo
07 108907 RK	R-5	Rural-5 Acre	Single Family Res-Combo
07 107479 RK	R-5	Rural-5 Acre	Single Family Res-Combo
07 107446 RK	R-5	Rural-5 Acre	Single Family Res-Combo
07 105521 RK	R-5	Rural-5 Acre	Single Family Res-Combo
07 108949 RK	R-5	Rural-5 Acre	Single Family Res-Combo
07 106239 RK	R-5	Rural-5 Acre	Single Family Res-Combo
07 106242 RK	R-5	Rural-5 Acre	Single Family Res-Combo
07 106244 RK	R-5	Rural-5 Acre	Single Family Res-Combo
07 110833 RK	R-7,200	Residential 7,200 sq. ft.	SFR-Basic
07 106554 RK	R-7,200	Residential 7,200 sq. ft.	Single Family Res-Combo
07 107028 RK	R-7,200	Residential 7,200 sq. ft.	Single Family Res-Combo
07 106556 RK	R-7,200	Residential 7,200 sq. ft.	Single Family Res-Combo

Accessory Dwelling Units

Index # - File Name: 1.0022 - Single Family Dwellings Data\_Snohomish County.pdf

07 107395 RK	R-7,200	Residential 7,200 sq. ft.	SFR-Basic
07 110412 RK	R-5	Rural-5 Acre	Single Family Res-Combo
07 104045 RK	R-5	Rural-5 Acre	Single Family Res-Combo
07 103855 RK	R-7,200	Residential 7,200 sq. ft.	SFR-Basic
07 112599 RK	R-7,200	Residential 7,200 sq. ft.	SFR-Basic
07 103412 RK	R-7,200	Residential 7,200 sq. ft.	SFR-Basic
07 101133 RK	R-7,200	Residential 7,200 sq. ft.	SFR-Basic
07 101132 RK	R-7,200	Residential 7,200 sq. ft.	SFR-Basic
07 105414 RK	R-7,200	Residential 7,200 sq. ft.	SFR-Basic
07 104914 RK	R-7,200	Residential 7,200 sq. ft.	SFR-Basic
07 113386 RK	R-7,200	Residential 7,200 sq. ft.	SFR-Basic
07 114468 RK	R-7,200	Residential 7,200 sq. ft.	SFR-Basic
07 109679 RK	R-7,200	Residential 7,200 sq. ft.	SFR-Basic
07 109733 RK	R-7,200	Residential 7,200 sq. ft.	SFR-Basic
07 113600 RK	R-7,200	Residential 7,200 sq. ft.	SFR-Basic
07 109448 RK	R-7,200	Residential 7,200 sq. ft.	SFR-Basic
07 106947 RK	R-7,200	Residential 7,200 sq. ft.	SFR-Basic
07 106948 RK	R-7,200	Residential 7,200 sq. ft.	SFR-Basic
07 107267 RK	R-7,200	Residential 7,200 sq. ft.	SFR-Basic
07 107268 RK	R-7,200	Residential 7,200 sq. ft.	SFR-Basic
07 103413 RK	R-7,200	Residential 7,200 sq. ft.	SFR-Basic
07 105413 RK	R-7,200	Residential 7,200 sq. ft.	SFR-Basic
07 101134 RK	R-7,200	Residential 7,200 sq. ft.	SFR-Basic
07 101317 RK	R-7,200	Residential 7,200 sq. ft.	SFR-Basic
07 105676 RK	R-7,200	Residential 7,200 sq. ft.	SFR-Basic
07 113385 RK	R-7,200	Residential 7,200 sq. ft.	SFR-Basic
07 114895 RK	R-7,200	Residential 7,200 sq. ft.	SFR-Basic
07 103727 RK	LDMR	Low Density Multiple Reside	SFR-Basic
07 100337 RK	LDMR	Low Density Multiple Reside	SFR-Basic
07 100338 RK	LDMR	Low Density Multiple Reside	SFR-Basic
07 102286 RK	MR	Multiple Residential	SFR-Basic
06 130683 RK	R-5	Rural-5 Acre	Single Family Res-Combo
07 101237 RK	R-9,600	Residential 9,600 sq. ft.	SFR-Basic
07 101510 RK	R-5	Rural-5 Acre	Single Family Res-Combo
07 101174 RK	R-5	Rural-5 Acre	Single Family Res-Combo
07 103725 RK	LDMR	Low Density Multiple Reside	SFR-Basic
06 137188 RK	LDMR	Low Density Multiple Reside	SFR-Basic
06 137189 RK	LDMR	Low Density Multiple Reside	SFR-Basic
07 101210 RK	LDMR	Low Density Multiple Reside	SFR-Basic
07 100358 RK	LDMR	Low Density Multiple Reside	SFR-Basic
07 101213 RK	LDMR	Low Density Multiple Reside	SFR-Basic
07 104908 RK	R-5	Rural-5 Acre	Single Family Res-Combo
07 108086 RK	A-10-SA	Agriculture-10 Acre, Sending	Single Family Res-Combo
06 130368 RK	R-5	Rural-5 Acre	Single Family Res-Combo
07 100062 RK	LDMR	Low Density Multiple Reside	SFR-Basic
07 104399 RK	LDMR	Low Density Multiple Reside	SFR-Basic
06 135663 RK	R-7,200	Residential 7,200 sq. ft.	SFR-Basic

Accessory Dwelling Units

Index # - File Name: 1.0022 - Single Family Dwellings Data\_Snohomish County.pdf

07 100173 RK	R-7,200	Residential 7,200 sq. ft.	SFR-Basic
07 105380 RK	R-7,200	Residential 7,200 sq. ft.	Single Family Res-Combo
07 105382 RK	R-7,200	Residential 7,200 sq. ft.	Single Family Res-Combo
07 105384 RK	R-7,200	Residential 7,200 sq. ft.	SFR-Basic
07 105452 RK	R-7,200	Residential 7,200 sq. ft.	Single Family Res-Combo
07 105453 RK	R-7,200	Residential 7,200 sq. ft.	Single Family Res-Combo
07 105291 RK	R-7,200	Residential 7,200 sq. ft.	SFR-Basic
07 105286 RK	R-7,200	Residential 7,200 sq. ft.	SFR-Basic
07 101825 RK	R-7,200	Residential 7,200 sq. ft.	SFR-Basic
07 101829 RK	R-7,200	Residential 7,200 sq. ft.	SFR-Basic
07 101834 RK	R-5	Rural-5 Acre	Single Family Res-Combo
06 135335 RK	CITY	City	SFR-Basic
06 135336 RK	CITY	City	SFR-Basic
06 135321 RK	CITY	City	SFR-Basic
06 135326 RK	CITY	City	SFR-Basic
06 135327 RK	CITY	City	SFR-Basic
06 135328 RK	CITY	City	SFR-Basic
06 135329 RK	CITY	City	SFR-Basic
06 135330 RK	CITY	City	SFR-Basic
07 100900 RK	R-7,200(PRD)	Residential 7,200 sq. ft.	SFR-Basic
07 102934 RK	R-7,200(PRD)	Residential 7,200 sq. ft.	SFR-Basic
07 102715 RK	LDMR	Low Density Multiple Reside	SFR-Basic
07 102716 RK	LDMR	Low Density Multiple Reside	SFR-Basic
06 130135 RK	LDMR	Low Density Multiple Reside	SFR-Basic
07 102717 RK	LDMR	Low Density Multiple Reside	SFR-Basic
07 105656 RK	LDMR	Low Density Multiple Reside	SFR-Basic
07 105652 RK	LDMR	Low Density Multiple Reside	SFR-Basic
07 105655 RK	LDMR	Low Density Multiple Reside	SFR-Basic
07 111273 RK	LDMR	Low Density Multiple Reside	SFR-Basic
07 112820 RK	R-5	Rural-5 Acre	SFR-Basic
07 112829 RK	R-5	Rural-5 Acre	SFR-Basic
07 112831 RK	R-5	Rural-5 Acre	SFR-Basic
07 112572 RK	R-5	Rural-5 Acre	SFR-Basic
07 107766 RK	LDMR	Low Density Multiple Reside	SFR-Basic
07 107767 RK	LDMR	Low Density Multiple Reside	SFR-Basic
07 107769 RK	LDMR	Low Density Multiple Reside	SFR-Basic
07 107770 RK	LDMR	Low Density Multiple Reside	SFR-Basic
07 107771 RK	LDMR	Low Density Multiple Reside	SFR-Basic
07 107772 RK	LDMR	Low Density Multiple Reside	SFR-Basic
07 100899 RK	R-7,200(PRD)	Residential 7,200 sq. ft.	SFR-Basic
07 100174 RK	R-7,200(PRD)	Residential 7,200 sq. ft.	SFR-Basic
07 100177 RK	R-7,200(PRD)	Residential 7,200 sq. ft.	SFR-Basic
07 100178 RK	R-7,200(PRD)	Residential 7,200 sq. ft.	SFR-Basic
07 100898 RK	R-7,200(PRD)	Residential 7,200 sq. ft.	SFR-Basic
07 100179 RK	R-7,200(PRD)	Residential 7,200 sq. ft.	SFR-Basic
06 133225 RK	R-7,200(PRD)	Residential 7,200 sq. ft.	SFR-Basic
07 100895 RK	R-7,200(PRD)	Residential 7,200 sq. ft.	SFR-Basic

Accessory Dwelling Units

Index # - File Name: 1.0022 - Single Family Dwellings Data\_Snohomish County.pdf

07 105295 RK	R-7,200(PRD)	Residential 7,200 sq. ft.	SFR-Basic
07 100891 RK	R-7,200(PRD)	Residential 7,200 sq. ft.	SFR-Basic
07 100576 RK	R-5	Rural-5 Acre	Single Family Res-Combo
07 104857 RK	R-7,200(PRD)	Residential 7,200 sq. ft.	SFR-Basic
07 104863 RK	R-7,200(PRD)	Residential 7,200 sq. ft.	SFR-Basic
07 100447 RK	R-7,200	Residential 7,200 sq. ft.	SFR-Basic
07 100448 RK	R-7,200	Residential 7,200 sq. ft.	SFR-Basic
07 100449 RK	R-7,200	Residential 7,200 sq. ft.	SFR-Basic
07 100450 RK	R-7,200	Residential 7,200 sq. ft.	SFR-Basic
07 101304 RK	R-7,200	Residential 7,200 sq. ft.	SFR-Basic
07 101305 RK	R-7,200	Residential 7,200 sq. ft.	SFR-Basic
07 107644 RK	R-7,200(PRD)	Residential 7,200 sq. ft.	SFR-Basic
07 104870 RK	R-7,200(PRD)	Residential 7,200 sq. ft.	SFR-Basic
07 104871 RK	R-7,200(PRD)	Residential 7,200 sq. ft.	SFR-Basic
07 110446 RK	R-7,200(PRD)	Residential 7,200 sq. ft.	SFR-Basic
07 104872 RK	R-7,200(PRD)	Residential 7,200 sq. ft.	SFR-Basic
07 104858 RK	R-7,200(PRD)	Residential 7,200 sq. ft.	SFR-Basic
07 110445 RK	R-7,200(PRD)	Residential 7,200 sq. ft.	SFR-Basic
07 104859 RK	R-7,200(PRD)	Residential 7,200 sq. ft.	SFR-Basic
07 104860 RK	R-7,200(PRD)	Residential 7,200 sq. ft.	SFR-Basic
07 109561 RK	LDMR	Low Density Multiple Reside	Single Family Res-Combo
06 136079 RK	LDMR	Low Density Multiple Reside	SFR-Basic
07 100632 RK	LDMR	Low Density Multiple Reside	SFR-Basic
07 100637 RK	LDMR	Low Density Multiple Reside	SFR-Basic
07 100636 RK	LDMR	Low Density Multiple Reside	SFR-Basic
07 100633 RK	LDMR	Low Density Multiple Reside	SFR-Basic
07 100628 RK	LDMR	Low Density Multiple Reside	SFR-Basic
06 129071 RK	R-5	Rural-5 Acre	Single Family Res-Combo
07 105359 RK	R-5	Rural-5 Acre	Single Family Res-Combo
07 101306 RK	R-7,200	Residential 7,200 sq. ft.	SFR-Basic
07 109559 RK	LDMR	Low Density Multiple Reside	Single Family Res-Combo
06 136078 RK	LDMR	Low Density Multiple Reside	SFR-Basic
07 101303 RK	R-7,200	Residential 7,200 sq. ft.	SFR-Basic
07 100445 RK	R-7,200	Residential 7,200 sq. ft.	SFR-Basic
07 100446 RK	R-7,200	Residential 7,200 sq. ft.	SFR-Basic
07 100051 RK	R-7,200	Residential 7,200 sq. ft.	SFR-Basic
07 101307 RK	R-7,200	Residential 7,200 sq. ft.	SFR-Basic
07 101301 RK	R-7,200	Residential 7,200 sq. ft.	SFR-Basic
07 101302 RK	R-7,200	Residential 7,200 sq. ft.	SFR-Basic
07 100444 RK	R-7,200	Residential 7,200 sq. ft.	SFR-Basic
07 102631 RK	R-7,200	Residential 7,200 sq. ft.	SFR-Basic
07 100277 RK	R-7,200	Residential 7,200 sq. ft.	SFR-Basic
07 101695 RK	R-7,200	Residential 7,200 sq. ft.	SFR-Basic
06 136997 RK	R-7,200	Residential 7,200 sq. ft.	SFR-Basic
07 101696 RK	R-7,200	Residential 7,200 sq. ft.	SFR-Basic
07 104218 RK	R-7,200	Residential 7,200 sq. ft.	SFR-Basic
07 102630 RK	R-7,200	Residential 7,200 sq. ft.	SFR-Basic

Accessory Dwelling Units

Index # - File Name: 1.0022 - Single Family Dwellings Data\_Snohomish County.pdf

07 104219 RK	R-7,200	Residential 7,200 sq. ft.	SFR-Basic
07 104838 RK	CITY	City	Single Family Res-Combo
07 104837 RK	CITY	City	Single Family Res-Combo
07 107022 RK	CITY	City	SFR-Basic
07 107026 RK	CITY	City	SFR-Basic
07 110444 RK	CITY	City	SFR-Basic
07 104839 RK	CITY	City	Single Family Res-Combo
07 105493 RK	CITY	City	SFR-Basic
07 105491 RK	CITY	City	SFR-Basic
07 105492 RK	CITY	City	SFR-Basic
07 107017 RK	CITY	City	SFR-Basic
07 113041 RK	CITY	City	SFR-Basic
07 113042 RK	CITY	City	SFR-Basic
07 107018 RK	CITY	City	SFR-Basic
07 107019 RK	CITY	City	SFR-Basic
07 110442 RK	CITY	City	SFR-Basic
07 110443 RK	CITY	City	SFR-Basic
07 107020 RK	CITY	City	SFR-Basic
07 107021 RK	CITY	City	SFR-Basic
07 114074 RK	CITY	City	SFR-Basic
07 107023 RK	CITY	City	SFR-Basic
07 107024 RK	CITY	City	SFR-Basic
07 112547 RK	CITY	City	SFR-Basic
07 107025 RK	CITY	City	SFR-Basic
07 102117 RK	A-10	Agriculture-10 Acre	Single Family Res-Combo
07 100374 RK	R-5	Rural-5 Acre	Single Family Res-Combo
07 103842 RK	PRD-9,600	Residential 9,600 sq. ft.	SFR-Basic
07 103843 RK	PRD-9,600	Residential 9,600 sq. ft.	SFR-Basic
07 103844 RK	PRD-9,600	Residential 9,600 sq. ft.	SFR-Basic
07 103845 RK	PRD-9,600	Residential 9,600 sq. ft.	SFR-Basic
07 103850 RK	PRD-9,600	Residential 9,600 sq. ft.	SFR-Basic
07 103851 RK	PRD-9,600	Residential 9,600 sq. ft.	SFR-Basic
07 103852 RK	PRD-9,600	Residential 9,600 sq. ft.	SFR-Basic
07 103853 RK	PRD-9,600	Residential 9,600 sq. ft.	SFR-Basic
07 104528 RK	LDMR	Low Density Multiple Reside	SFR-Basic
07 104525 RK	LDMR	Low Density Multiple Reside	SFR-Basic
07 104526 RK	LDMR	Low Density Multiple Reside	SFR-Basic
07 106519 RK	PRD-9,600	Residential 9,600 sq. ft.	SFR-Basic
07 106529 RK	PRD-9,600	Residential 9,600 sq. ft.	SFR-Basic
07 106520 RK	PRD-9,600	Residential 9,600 sq. ft.	SFR-Basic
07 106523 RK	PRD-9,600	Residential 9,600 sq. ft.	SFR-Basic
07 106524 RK	PRD-9,600	Residential 9,600 sq. ft.	SFR-Basic
07 106525 RK	PRD-9,600	Residential 9,600 sq. ft.	SFR-Basic
07 106526 RK	PRD-9,600	Residential 9,600 sq. ft.	SFR-Basic
07 106527 RK	PRD-9,600	Residential 9,600 sq. ft.	SFR-Basic
07 101396 RK	PRD-9,600	Residential 9,600 sq. ft.	SFR-Basic
07 101397 RK	PRD-9,600	Residential 9,600 sq. ft.	SFR-Basic

Accessory Dwelling Units

Index # - File Name: 1.0022 - Single Family Dwellings Data\_Snohomish County.pdf

07 101398 RK	PRD-9,600	Residential 9,600 sq. ft.	SFR-Basic
07 101399 RK	PRD-9,600	Residential 9,600 sq. ft.	SFR-Basic
07 101400 RK	PRD-9,600	Residential 9,600 sq. ft.	SFR-Basic
07 101401 RK	PRD-9,600	Residential 9,600 sq. ft.	SFR-Basic
07 102729 RK	LDMR	Low Density Multiple Reside	SFR-Basic
07 102732 RK	LDMR	Low Density Multiple Reside	SFR-Basic
07 102733 RK	LDMR	Low Density Multiple Reside	SFR-Basic
07 102734 RK	LDMR	Low Density Multiple Reside	SFR-Basic
07 102244 RK	LDMR	Low Density Multiple Reside	SFR-Basic
07 102246 RK	LDMR	Low Density Multiple Reside	SFR-Basic
07 102235 RK	LDMR	Low Density Multiple Reside	SFR-Basic
07 102238 RK	LDMR	Low Density Multiple Reside	SFR-Basic
07 102240 RK	LDMR	Low Density Multiple Reside	SFR-Basic
07 102242 RK	LDMR	Low Density Multiple Reside	SFR-Basic
07 102243 RK	LDMR	Low Density Multiple Reside	SFR-Basic
07 102646 RK	CITY	City	SFR-Basic
07 101119 RK	CITY	City	SFR-Basic
07 101527 RK	CITY	City	SFR-Basic
07 113611 RK	CITY	City	SFR-Basic
07 102647 RK	CITY	City	SFR-Basic
07 104039 RK	CITY	City	SFR-Basic
07 105416 RK	CITY	City	SFR-Basic
07 106328 RK	CITY	City	SFR-Basic
07 109449 RK	CITY	City	SFR-Basic
07 101952 RK	CITY	City	SFR-Basic
07 101585 RK	CITY	City	SFR-Basic
07 106950 RK	CITY	City	SFR-Basic
07 106651 RK	CITY	City	SFR-Basic
07 101879 RK	CITY	City	SFR-Basic
07 103427 RK	CITY	City	SFR-Basic
07 104915 RK	CITY	City	SFR-Basic
07 110236 RK	CITY	City	SFR-Basic
07 106949 RK	CITY	City	SFR-Basic
07 110613 RK	CITY	City	SFR-Basic
07 105415 RK	CITY	City	SFR-Basic
07 103425 RK	CITY	City	SFR-Basic
07 102997 RK	CITY	City	SFR-Basic
07 101288 RK	CITY	City	SFR-Basic
07 100457 RK	CITY	City	SFR-Basic
07 100458 RK	CITY	City	SFR-Basic
07 101117 RK	CITY	City	SFR-Basic
07 100919 RK	CITY	City	SFR-Basic
07 100691 RK	CITY	City	SFR-Basic
07 101316 RK	CITY	City	SFR-Basic
07 109201 RK	CITY	City	SFR-Basic
07 100459 RK	CITY	City	SFR-Basic
07 107908 RK	CITY	City	SFR-Basic



Accessory Dwelling Units

Index # - File Name: 1.0022 - Single Family Dwellings Data\_Snohomish County.pdf

06 135691 RK	CITY	City	SFR-Basic
07 110614 RK	CITY	City	SFR-Basic
07 113387 RK	CITY	City	SFR-Basic
07 110851 RK	CITY	City	SFR-Basic
07 102277 RK	CITY	City	SFR-Basic
07 102998 RK	CITY	City	SFR-Basic
07 114701 RK	CITY	City	SFR-Basic
07 113389 RK	CITY	City	SFR-Basic
07 101005 RK	CITY	City	SFR-Basic
07 100692 RK	CITY	City	SFR-Basic
07 101361 RK	CITY	City	SFR-Basic
07 101289 RK	CITY	City	SFR-Basic
07 101290 RK	CITY	City	SFR-Basic
07 101523 RK	CITY	City	SFR-Basic
07 102095 RK	CITY	City	SFR-Basic
07 102096 RK	CITY	City	SFR-Basic
07 102434 RK	CITY	City	SFR-Basic
07 110237 RK	CITY	City	SFR-Basic
07 103426 RK	CITY	City	SFR-Basic
07 105417 RK	CITY	City	SFR-Basic
07 110238 RK	CITY	City	SFR-Basic
07 110239 RK	CITY	City	SFR-Basic
07 109735 RK	CITY	City	SFR-Basic
07 109202 RK	CITY	City	SFR-Basic
07 110615 RK	CITY	City	SFR-Basic
07 110240 RK	CITY	City	SFR-Basic
07 107269 RK	CITY	City	SFR-Basic
07 110241 RK	CITY	City	SFR-Basic
07 109198 RK	CITY	City	SFR-Basic
07 106650 RK	CITY	City	SFR-Basic
07 110852 RK	CITY	City	SFR-Basic
07 111276 RK	CITY	City	SFR-Basic
07 100918 RK	CITY	City	SFR-Basic
07 113388 RK	CITY	City	SFR-Basic
07 112976 RK	CITY	City	SFR-Basic
07 113606 RK	CITY	City	SFR-Basic
07 114471 RK	CITY	City	SFR-Basic
07 114472 RK	CITY	City	SFR-Basic
07 114473 RK	CITY	City	SFR-Basic
07 114474 RK	CITY	City	SFR-Basic
06 134586 RK	R-5	Rural-5 Acre	Single Family Res-Combo
06 131853 RK	R-5	Rural-5 Acre	Single Family Res-Combo
07 100913 RK	CITY	City	Single Family Res-Combo
07 101269 RK	CITY	City	Single Family Res-Combo
06 135930 RK	CITY	City	Single Family Res-Combo
07 111235 RK	R-5	Rural-5 Acre	Single Family Res-Combo
06 127095 RK	MR	Multiple Residential	SFR-Basic

Accessory Dwelling Units

Index # - File Name: 1.0022 - Single Family Dwellings Data\_Snohomish County.pdf

06 127088 RK	MR	Multiple Residential	SFR-Basic
06 127089 RK	MR	Multiple Residential	SFR-Basic
06 127090 RK	MR	Multiple Residential	SFR-Basic
06 135343 RK	CITY	City	SFR-Basic
06 135344 RK	CITY	City	SFR-Basic
06 135341 RK	CITY	City	SFR-Basic
06 134873 RK	CITY	City	SFR-Basic
07 108146 RK	F	Forestry	Single Family Res-Combo
06 129418 RK	R-5	Rural-5 Acre	Single Family Res-Combo
06 134866 RK	CITY	City	SFR-Basic
06 135275 RK	CITY	City	SFR-Basic
06 134871 RK	CITY	City	SFR-Basic
06 134872 RK	CITY	City	SFR-Basic
07 103369 RK	CITY	City	Single Family Res-Combo
07 103370 RK	CITY	City	Single Family Res-Combo
07 103028 RK	R-7,200	Residential 7,200 sq. ft.	SFR-Basic
07 100088 RK	R-7,200	Residential 7,200 sq. ft.	SFR-Basic
06 135021 RK	R-7,200	Residential 7,200 sq. ft.	Single Family Res-Combo
07 100785 RK	R-7,200	Residential 7,200 sq. ft.	SFR-Basic
07 100787 RK	R-7,200	Residential 7,200 sq. ft.	Single Family Res-Combo
07 102293 RK	A-10	Agriculture-10 Acre	Single Family Res-Combo
07 102425 RK	LDMR	Low Density Multiple Reside	SFR-Basic
07 102426 RK	LDMR	Low Density Multiple Reside	SFR-Basic
07 102427 RK	LDMR	Low Density Multiple Reside	SFR-Basic
07 102428 RK	LDMR	Low Density Multiple Reside	SFR-Basic
07 100052 RK	R-7,200	Residential 7,200 sq. ft.	SFR-Basic
07 100053 RK	R-7,200	Residential 7,200 sq. ft.	SFR-Basic
07 100055 RK	R-7,200	Residential 7,200 sq. ft.	SFR-Basic
07 102875 RK	R-7,200	Residential 7,200 sq. ft.	Single Family Res-Combo
07 102247 RK	R-7,200	Residential 7,200 sq. ft.	SFR-Basic
07 102237 RK	R-7,200	Residential 7,200 sq. ft.	SFR-Basic
07 101455 RK	R-7,200	Residential 7,200 sq. ft.	SFR-Basic
07 101456 RK	R-7,200	Residential 7,200 sq. ft.	SFR-Basic
07 101457 RK	R-7,200	Residential 7,200 sq. ft.	SFR-Basic
07 100090 RK	R-7,200	Residential 7,200 sq. ft.	SFR-Basic
06 134376 RK	R-7,200	Residential 7,200 sq. ft.	Single Family Res-Combo
06 134810 RK	R-7,200	Residential 7,200 sq. ft.	Single Family Res-Combo
07 101836 RK	R-7,200	Residential 7,200 sq. ft.	SFR-Basic
07 101837 RK	R-7,200	Residential 7,200 sq. ft.	SFR-Basic
07 105220 RK	R-7,200	Residential 7,200 sq. ft.	Single Family Res-Combo
07 102590 RK	R-7,200	Residential 7,200 sq. ft.	SFR-Basic
07 103312 RK	R-7,200	Residential 7,200 sq. ft.	SFR-Basic
07 102833 RK	R-7,200	Residential 7,200 sq. ft.	SFR-Basic
07 102591 RK	R-7,200	Residential 7,200 sq. ft.	SFR-Basic
07 102920 RK	R-7,200	Residential 7,200 sq. ft.	SFR-Basic
07 101838 RK	R-7,200	Residential 7,200 sq. ft.	SFR-Basic
06 134375 RK	R-7,200	Residential 7,200 sq. ft.	Single Family Res-Combo

Accessory Dwelling Units

Index # - File Name: 1.0022 - Single Family Dwellings Data\_Snohomish County.pdf

07 100974 RK	MR	Multiple Residential	SFR-Basic
07 101841 RK	MR	Multiple Residential	SFR-Basic
07 101844 RK	MR	Multiple Residential	SFR-Basic
07 104708 RK	MR	Multiple Residential	SFR-Basic
07 107812 RK	MR	Multiple Residential	SFR-Basic
07 100502 RK	R-7,200	Residential 7,200 sq. ft.	SFR-Basic
06 131845 RK	RC	Rural Conservation	Single Family Res-Combo
07 105647 RK	MR	Multiple Residential	SFR-Basic
07 105648 RK	MR	Multiple Residential	SFR-Basic
07 106419 RK	MR	Multiple Residential	SFR-Basic
07 104707 RK	MR	Multiple Residential	SFR-Basic
07 100975 RK	MR	Multiple Residential	SFR-Basic
07 100978 RK	MR	Multiple Residential	SFR-Basic
07 100980 RK	MR	Multiple Residential	SFR-Basic
07 101842 RK	MR	Multiple Residential	SFR-Basic
07 101843 RK	MR	Multiple Residential	SFR-Basic
07 101845 RK	MR	Multiple Residential	SFR-Basic
07 101846 RK	MR	Multiple Residential	SFR-Basic
07 104713 RK	MR	Multiple Residential	SFR-Basic
07 104714 RK	MR	Multiple Residential	SFR-Basic
07 104715 RK	MR	Multiple Residential	SFR-Basic
07 104716 RK	MR	Multiple Residential	SFR-Basic
07 104717 RK	MR	Multiple Residential	SFR-Basic
06 135129 RK	LDMR	Low Density Multiple Reside	Single Family Res-Combo
06 135130 RK	LDMR	Low Density Multiple Reside	Single Family Res-Combo
07 100500 RK	R-7,200	Residential 7,200 sq. ft.	SFR-Basic
07 100501 RK	R-7,200	Residential 7,200 sq. ft.	SFR-Basic
07 102870 RK	R-7,200	Residential 7,200 sq. ft.	SFR-Basic
07 102223 RK	R-7,200	Residential 7,200 sq. ft.	SFR-Basic
07 106757 RK	R-7,200	Residential 7,200 sq. ft.	SFR-Basic
07 101297 RK	R-7,200	Residential 7,200 sq. ft.	SFR-Basic
07 100998 RK	R-7,200	Residential 7,200 sq. ft.	SFR-Basic
07 101298 RK	R-7,200	Residential 7,200 sq. ft.	SFR-Basic
07 108047 RK	R-7,200	Residential 7,200 sq. ft.	SFR-Basic
07 105243 RK	R-7,200	Residential 7,200 sq. ft.	SFR-Basic
07 102047 RK	R-7,200	Residential 7,200 sq. ft.	SFR-Basic
07 107097 RK	R-7,200	Residential 7,200 sq. ft.	SFR-Basic
07 103011 RK	R-7,200	Residential 7,200 sq. ft.	SFR-Basic
07 103012 RK	R-7,200	Residential 7,200 sq. ft.	SFR-Basic
06 136992 RK	R-5	Rural-5 Acre	Single Family Res-Combo
06 133697 RK	R-7,200	Residential 7,200 sq. ft.	SFR-Basic
07 113393 RK	R-7,200	Residential 7,200 sq. ft.	SFR-Basic
07 110812 RK	R-7,200	Residential 7,200 sq. ft.	SFR-Basic
07 106023 RK	R-7,200	Residential 7,200 sq. ft.	SFR-Basic
07 102664 RK	R-7,200	Residential 7,200 sq. ft.	SFR-Basic
07 107093 RK	R-7,200	Residential 7,200 sq. ft.	SFR-Basic
07 104237 RK	R-7,200	Residential 7,200 sq. ft.	SFR-Basic

Accessory Dwelling Units

Index # - File Name: 1.0022 - Single Family Dwellings Data\_Snohomish County.pdf

07 113399 RK	R-7,200	Residential 7,200 sq. ft.	SFR-Basic
07 107087 RK	R-7,200	Residential 7,200 sq. ft.	SFR-Basic
07 100034 RK	R-5	Rural-5 Acre	Single Family Res-Combo
07 110654 RK	R-7,200	Residential 7,200 sq. ft.	SFR-Basic
07 110655 RK	R-7,200	Residential 7,200 sq. ft.	SFR-Basic
07 113471 RK	R-7,200	Residential 7,200 sq. ft.	SFR-Basic
07 110037 RK	R-5	Rural-5 Acre	Single Family Res-Combo
07 101404 RK	R-9,600	Residential 9,600 sq. ft.	SFR-Basic
07 104121 RK	R-9,600	Residential 9,600 sq. ft.	SFR-Basic
07 104122 RK	R-9,600	Residential 9,600 sq. ft.	SFR-Basic
07 110652 RK	R-7,200	Residential 7,200 sq. ft.	SFR-Basic
07 110653 RK	R-7,200	Residential 7,200 sq. ft.	SFR-Basic
07 110650 RK	R-7,200	Residential 7,200 sq. ft.	SFR-Basic
07 110651 RK	R-7,200	Residential 7,200 sq. ft.	SFR-Basic
07 104235 RK	R-7,200	Residential 7,200 sq. ft.	SFR-Basic
07 106024 RK	R-7,200	Residential 7,200 sq. ft.	SFR-Basic
07 104236 RK	R-7,200	Residential 7,200 sq. ft.	SFR-Basic
07 102046 RK	R-7,200	Residential 7,200 sq. ft.	SFR-Basic
07 107082 RK	R-7,200	Residential 7,200 sq. ft.	SFR-Basic
07 106755 RK	R-7,200	Residential 7,200 sq. ft.	SFR-Basic
07 101312 RK	R-7,200	Residential 7,200 sq. ft.	SFR-Basic
07 113880 RK	R-7,200	Residential 7,200 sq. ft.	SFR-Basic
07 101767 RK	R-5	Rural-5 Acre	Single Family Res-Combo
06 135723 RK	R-5	Rural-5 Acre	Single Family Res-Combo
06 135722 RK	R-5	Rural-5 Acre	Single Family Res-Combo
06 135983 RK	R-8,400	Residential 8,400 sq. ft.	Single Family Res-Combo
07 101403 RK	R-9,600	Residential 9,600 sq. ft.	SFR-Basic
07 101239 RK	R-5	Rural-5 Acre	Single Family Res-Combo
06 102859 RK	F	Forestry	Single Family Res-Combo
07 104722 RK	LDMR	Low Density Multiple Reside	SFR-Basic
07 103018 RK	LDMR	Low Density Multiple Reside	SFR-Basic
07 104723 RK	LDMR	Low Density Multiple Reside	SFR-Basic
07 102878 RK	LDMR	Low Density Multiple Reside	SFR-Basic
07 102879 RK	LDMR	Low Density Multiple Reside	SFR-Basic
07 103019 RK	LDMR	Low Density Multiple Reside	SFR-Basic
07 102877 RK	LDMR	Low Density Multiple Reside	SFR-Basic
07 101206 RK	R-5	Rural-5 Acre	SFR-Basic
07 104015 RK	LDMR	Low Density Multiple Reside	SFR-Basic
07 104010 RK	LDMR	Low Density Multiple Reside	SFR-Basic
07 101979 RK	R-5	Rural-5 Acre	SFR-Basic
07 101483 RK	R-5	Rural-5 Acre	SFR-Basic
07 104725 RK	LDMR	Low Density Multiple Reside	SFR-Basic
07 104009 RK	LDMR	Low Density Multiple Reside	SFR-Basic
07 104012 RK	LDMR	Low Density Multiple Reside	SFR-Basic
07 104013 RK	LDMR	Low Density Multiple Reside	SFR-Basic
06 132794 RK	R-5	Rural-5 Acre	SFR-Basic
06 132107 RK	R-5	Rural-5 Acre	SFR-Basic

Accessory Dwelling Units

Index # - File Name: 1.0022 - Single Family Dwellings Data\_Snohomish County.pdf

06 133132 RK	R-7,200	Residential 7,200 sq. ft.	SFR-Basic
07 100359 RK	R-7,200	Residential 7,200 sq. ft.	SFR-Basic
07 100360 RK	R-7,200	Residential 7,200 sq. ft.	SFR-Basic
06 126290 RK	R-5	Rural-5 Acre	SFR-Basic
06 130453 RK	R-5	Rural-5 Acre	Single Family Res-Combo
07 109630 RK	R-5	Rural-5 Acre	Single Family Res-Combo
07 110556 RK	R-5	Rural-5 Acre	Single Family Res-Combo
07 109365 RK	R-5	Rural-5 Acre	Duplex-Basic
07 110260 RK	R-5	Rural-5 Acre	Single Family Res-Combo
07 110563 RK	MR	Multiple Residential	Duplex-Combo
07 113868 RK	CITY	City	SFR-Basic
07 113869 RK	CITY	City	SFR-Basic
07 113773 RK	CITY	City	SFR-Basic
07 113774 RK	CITY	City	SFR-Basic
07 113771 RK	CITY	City	SFR-Basic
07 113772 RK	CITY	City	SFR-Basic
07 111500 RK	TRIBES	Native American Land	Single Family Res-Combo
07 113011 RK	R-7,200	Residential 7,200 sq. ft.	SFR-Basic
07 111258 RK	MR	Multiple Residential	SFR-Basic
07 111263 RK	MR	Multiple Residential	SFR-Basic
07 111261 RK	MR	Multiple Residential	SFR-Basic
07 111266 RK	MR	Multiple Residential	SFR-Basic
07 111260 RK	MR	Multiple Residential	SFR-Basic
07 111259 RK	MR	Multiple Residential	SFR-Basic
07 102328 RK	R-5	Rural-5 Acre	Duplex-Combo
07 112012 RK	CITY	City	SFR-Basic
07 112010 RK	CITY	City	SFR-Basic
07 111481 RK	R-5	Rural-5 Acre	Single Family Res-Combo
07 110605 RK	R-7,200	Residential 7,200 sq. ft.	Single Family Res-Combo
07 113965 RK	R-9,600	Residential 9,600 sq. ft.	Single Family Res-Combo
07 113969 RK	R-9,600	Residential 9,600 sq. ft.	Single Family Res-Combo
07 113966 RK	R-9,600	Residential 9,600 sq. ft.	Single Family Res-Combo
07 114163 RK	R-9,600	Residential 9,600 sq. ft.	Single Family Res-Combo
07 112824 RK	R-5	Rural-5 Acre	SFR-Basic
07 104484 RK	R-5	Rural-5 Acre	Single Family Res-Combo
07 106345 RK	R-8,400	Residential 8,400 sq. ft.	Single Family Res-Combo
07 105713 RK	R-12,500	Residential 12,500 sq. ft.	Single Family Res-Combo
07 104291 MH	R-5	Rural-5 Acre	Triple Wide
07 113372 RK	R-9,600	Residential 9,600 sq. ft.	SFR-Basic
07 113373 RK	R-9,600	Residential 9,600 sq. ft.	SFR-Basic
07 113374 RK	R-9,600	Residential 9,600 sq. ft.	SFR-Basic
07 113377 RK	R-9,600	Residential 9,600 sq. ft.	SFR-Basic
07 113375 RK	R-9,600	Residential 9,600 sq. ft.	SFR-Basic
07 113378 RK	R-9,600	Residential 9,600 sq. ft.	SFR-Basic
07 113379 RK	R-9,600	Residential 9,600 sq. ft.	SFR-Basic
07 113380 RK	R-9,600	Residential 9,600 sq. ft.	SFR-Basic
07 113381 RK	R-9,600	Residential 9,600 sq. ft.	SFR-Basic

Accessory Dwelling Units

Index # - File Name: 1.0022 - Single Family Dwellings Data\_Snohomish County.pdf

07 113382 RK	R-9,600	Residential 9,600 sq. ft.	SFR-Basic
07 107784 RK	R-5	Rural-5 Acre	SFR-Basic
07 106414 RK	R-5	Rural-5 Acre	Single Family Res-Combo
07 107107 RK	R-5	Rural-5 Acre	Single Family Res-Combo
07 105850 RK	R-5	Rural-5 Acre	SFR-Basic
07 106109 RK	R-5	Rural-5 Acre	SFR-Basic
07 105517 RK	R-5	Rural-5 Acre	Single Family Res-Combo
07 105486 RK	R-5	Rural-5 Acre	Single Family Res-Combo
07 106495 RK	R-5	Rural-5 Acre	Single Family Res-Combo
07 102195 RK	R-5	Rural-5 Acre	Single Family Res-Combo
07 102196 RK	R-5	Rural-5 Acre	Single Family Res-Combo
07 105847 RK	R-5	Rural-5 Acre	SFR-Basic
07 106118 RK	R-5	Rural-5 Acre	SFR-Basic
07 106799 RK	R-7,200	Residential 7,200 sq. ft.	Single Family Res-Combo
07 106116 RK	R-5	Rural-5 Acre	SFR-Basic
07 106112 RK	R-5	Rural-5 Acre	SFR-Basic
07 106153 RK	R-5	Rural-5 Acre	Single Family Res-Combo
07 105848 RK	R-5	Rural-5 Acre	SFR-Basic
07 107781 RK	R-5	Rural-5 Acre	SFR-Basic
07 107782 RK	R-5	Rural-5 Acre	SFR-Basic
07 104848 RK	R-5	Rural-5 Acre	SFR-Basic
07 104898 RK	F	Forestry	Single Family Res-Combo
07 107925 RK	CITY	City	SFR-Basic
07 107926 RK	CITY	City	SFR-Basic
07 107927 RK	CITY	City	SFR-Basic
07 107928 RK	CITY	City	SFR-Basic
07 107929 RK	CITY	City	SFR-Basic
07 107938 RK	CITY	City	SFR-Basic
07 107931 RK	CITY	City	SFR-Basic
07 107932 RK	CITY	City	SFR-Basic
07 107933 RK	CITY	City	SFR-Basic
07 107934 RK	CITY	City	SFR-Basic
07 107945 RK	CITY	City	SFR-Basic
07 113310 RK	R-7,200	Residential 7,200 sq. ft.	Single Family Res-Combo
07 112262 RK	R-7,200	Residential 7,200 sq. ft.	Single Family Res-Combo
07 105339 RK	R-5	Rural-5 Acre	Single Family Res-Combo
07 109941 RK	R-7,200	Residential 7,200 sq. ft.	SFR-Basic
07 106214 RK	CITY	City	SFR-Basic
07 110229 RK	R-5	Rural-5 Acre	Single Family Res-Combo
07 107833 RK	R-5	Rural-5 Acre	Single Family Res-Combo
07 106809 RK	R-5	Rural-5 Acre	Single Family Res-Combo
07 106814 RK	R-5	Rural-5 Acre	Single Family Res-Combo
07 107852 RK	R-5	Rural-5 Acre	Single Family Res-Combo
07 108031 RK	R-5	Rural-5 Acre	SFR-Basic
07 108025 RK	R-5	Rural-5 Acre	SFR-Basic
07 108029 RK	R-5	Rural-5 Acre	SFR-Basic
07 107398 RK	R-5	Rural-5 Acre	SFR-Basic

Accessory Dwelling Units

Index # - File Name: 1.0022 - Single Family Dwellings Data\_Snohomish County.pdf

07 111154 RK	LDMR	Low Density Multiple Reside	SFR-Basic
07 111155 RK	LDMR	Low Density Multiple Reside	SFR-Basic
07 111156 RK	LDMR	Low Density Multiple Reside	SFR-Basic
07 111157 RK	LDMR	Low Density Multiple Reside	SFR-Basic
07 111158 RK	LDMR	Low Density Multiple Reside	SFR-Basic
07 111159 RK	LDMR	Low Density Multiple Reside	SFR-Basic
07 105773 RK	R-5	Rural-5 Acre	Single Family Res-Combo
07 106802 RK	R-7,200	Residential 7,200 sq. ft.	Duplex-Basic
07 109755 RK	LDMR	Low Density Multiple Reside	SFR-Basic
07 109756 RK	LDMR	Low Density Multiple Reside	SFR-Basic
07 110263 RK	LDMR	Low Density Multiple Reside	SFR-Basic
07 110264 RK	LDMR	Low Density Multiple Reside	SFR-Basic
07 114676 RK	R-7,200	Residential 7,200 sq. ft.	SFR-Basic
07 112143 RK	R-7,200	Residential 7,200 sq. ft.	SFR-Basic
07 110794 RK	R-7,200	Residential 7,200 sq. ft.	SFR-Basic
07 110790 RK	R-7,200	Residential 7,200 sq. ft.	SFR-Basic
07 110787 RK	R-7,200	Residential 7,200 sq. ft.	SFR-Basic
07 110796 RK	R-7,200	Residential 7,200 sq. ft.	SFR-Basic
07 110798 RK	R-7,200	Residential 7,200 sq. ft.	SFR-Basic
07 106148 RK	A-10	Agriculture-10 Acre	Single Family Res-Combo
07 106199 RK	R-5	Rural-5 Acre	SFR-Basic
07 106196 RK	R-5	Rural-5 Acre	SFR-Basic
07 106560 RK	R-5	Rural-5 Acre	Single Family Res-Combo
07 106645 RK	R-5	Rural-5 Acre	Single Family Res-Combo
07 109432 RK	CITY	City	SFR-Basic
07 108166 RK	CITY	City	SFR-Basic
07 108165 RK	CITY	City	SFR-Basic
07 109431 RK	CITY	City	SFR-Basic
07 110255 RK	CITY	City	SFR-Basic
07 106881 RK	R-5	Rural-5 Acre	Single Family Res-Combo
07 106874 RK	R-5	Rural-5 Acre	Single Family Res-Combo
07 110670 RK	R-5	Rural-5 Acre	Single Family Res-Combo
07 107830 RK	R-5	Rural-5 Acre	Single Family Res-Combo
07 107976 RK	R-5	Rural-5 Acre	Single Family Res-Combo
07 108671 RK	R-5	Rural-5 Acre	Single Family Res-Combo
07 108672 RK	R-5	Rural-5 Acre	Single Family Res-Combo
07 108685 RK	A-10	Agriculture-10 Acre	Single Family Res-Combo
07 108704 RK	F	Forestry	Single Family Res-Combo
07 108783 RK	R-5	Rural-5 Acre	Single Family Res-Combo
07 108893 RK	LDMR	Low Density Multiple Reside	Duplex-Combo
07 108895 RK	LDMR	Low Density Multiple Reside	Duplex-Combo
07 108896 RK	LDMR	Low Density Multiple Reside	Duplex-Combo
07 108897 RK	LDMR	Low Density Multiple Reside	Duplex-Combo
07 108648 RK	RC	Rural Conservation	Single Family Res-Combo
06 134753 RK	R-5	Rural-5 Acre	Single Family Res-Combo
07 109789 RK	F	Forestry	Single Family Res-Combo
07 107161 RK	R-9,600	Residential 9,600 sq. ft.	Single Family Res-Combo

Accessory Dwelling Units

Index # - File Name: 1.0022 - Single Family Dwellings Data\_Snohomish County.pdf

08 101640 RK	R-12,500	Residential 12,500 sq. ft.	Single Family Res-Combo
08 109902 RK	R-9,600	Residential 9,600 sq. ft.	SFR-Basic
08 109903 RK	R-9,600	Residential 9,600 sq. ft.	SFR-Basic
08 110980 RK	R-9,600	Residential 9,600 sq. ft.	SFR-Basic
08 110981 RK	R-9,600	Residential 9,600 sq. ft.	SFR-Basic
08 106733 RK	R-5	Rural-5 Acre	Single Family Res-Combo
08 106728 RK	R-5	Rural-5 Acre	Single Family Res-Combo
08 104505 RK	R-5	Rural-5 Acre	Single Family Res-Combo
08 104513 RK	R-5	Rural-5 Acre	Single Family Res-Combo
08 104510 RK	R-5	Rural-5 Acre	Single Family Res-Combo
08 105173 RK	R-7,200	Residential 7,200 sq. ft.	SFR-Basic
08 105172 RK	R-7,200	Residential 7,200 sq. ft.	SFR-Basic
08 100828 RK	R-5	Rural-5 Acre	Single Family Res-Combo
08 100800 RK	CITY	City	Duplex-Combo
08 100890 RK	F	Forestry	SFR-Basic
08 103900 RK	WFB	Waterfront Beach	Single Family Res-Combo
08 105171 RK	R-7,200	Residential 7,200 sq. ft.	SFR-Basic
08 102204 RK	R-8,400	Residential 8,400 sq. ft.	SFR-Basic
08 102205 RK	R-8,400	Residential 8,400 sq. ft.	SFR-Basic
08 102206 RK	R-8,400	Residential 8,400 sq. ft.	SFR-Basic
08 102207 RK	R-8,400	Residential 8,400 sq. ft.	SFR-Basic
08 102312 RK	R-5	Rural-5 Acre	Single Family Res-Combo
08 108616 RK	LDMR	Low Density Multiple Reside	SFR-Basic
08 108623 RK	LDMR	Low Density Multiple Reside	SFR-Basic
08 108624 RK	LDMR	Low Density Multiple Reside	SFR-Basic
08 108625 RK	LDMR	Low Density Multiple Reside	SFR-Basic
08 108707 RK	LDMR	Low Density Multiple Reside	SFR-Basic
08 108708 RK	LDMR	Low Density Multiple Reside	SFR-Basic
08 108709 RK	LDMR	Low Density Multiple Reside	SFR-Basic
08 108626 RK	LDMR	Low Density Multiple Reside	SFR-Basic
08 108627 RK	LDMR	Low Density Multiple Reside	SFR-Basic
08 108617 RK	LDMR	Low Density Multiple Reside	SFR-Basic
08 108618 RK	LDMR	Low Density Multiple Reside	SFR-Basic
08 108619 RK	LDMR	Low Density Multiple Reside	SFR-Basic
08 108620 RK	LDMR	Low Density Multiple Reside	SFR-Basic
08 108621 RK	LDMR	Low Density Multiple Reside	SFR-Basic
08 108622 RK	LDMR	Low Density Multiple Reside	SFR-Basic
08 108710 RK	LDMR	Low Density Multiple Reside	SFR-Basic
08 108705 RK	LDMR	Low Density Multiple Reside	SFR-Basic
08 108706 RK	LDMR	Low Density Multiple Reside	SFR-Basic
08 108991 RK	LDMR	Low Density Multiple Reside	SFR-Basic
08 109046 RK	LDMR	Low Density Multiple Reside	SFR-Basic
08 109047 RK	LDMR	Low Density Multiple Reside	SFR-Basic
08 109048 RK	LDMR	Low Density Multiple Reside	SFR-Basic
08 107297 RK	LDMR	Low Density Multiple Reside	SFR-Basic
08 107298 RK	LDMR	Low Density Multiple Reside	SFR-Basic
08 102208 RK	R-8,400	Residential 8,400 sq. ft.	SFR-Basic



Accessory Dwelling Units

Index # - File Name: 1.0022 - Single Family Dwellings Data\_Snohomish County.pdf

08 107278 RK	LDMR	Low Density Multiple Reside	SFR-Basic
08 107279 RK	LDMR	Low Density Multiple Reside	SFR-Basic
08 107280 RK	LDMR	Low Density Multiple Reside	SFR-Basic
08 107281 RK	LDMR	Low Density Multiple Reside	SFR-Basic
08 107282 RK	LDMR	Low Density Multiple Reside	SFR-Basic
08 107283 RK	LDMR	Low Density Multiple Reside	SFR-Basic
08 107284 RK	LDMR	Low Density Multiple Reside	SFR-Basic
08 107285 RK	LDMR	Low Density Multiple Reside	SFR-Basic
08 107286 RK	LDMR	Low Density Multiple Reside	SFR-Basic
08 107287 RK	LDMR	Low Density Multiple Reside	SFR-Basic
08 107288 RK	LDMR	Low Density Multiple Reside	SFR-Basic
08 107289 RK	LDMR	Low Density Multiple Reside	SFR-Basic
08 107290 RK	LDMR	Low Density Multiple Reside	SFR-Basic
08 107291 RK	LDMR	Low Density Multiple Reside	SFR-Basic
08 107292 RK	LDMR	Low Density Multiple Reside	SFR-Basic
08 107296 RK	LDMR	Low Density Multiple Reside	SFR-Basic
08 108408 RK	MR	Multiple Residential	Single Family Res-Combo
08 107882 RK	MR	Multiple Residential	Single Family Res-Combo
08 108413 RK	MR	Multiple Residential	Single Family Res-Combo
08 107816 RK	CITY	City	Single Family Res-Combo
08 107815 RK	CITY	City	Single Family Res-Combo
08 107884 RK	MR	Multiple Residential	Single Family Res-Combo
08 107886 RK	MR	Multiple Residential	Single Family Res-Combo
08 107887 RK	MR	Multiple Residential	Single Family Res-Combo
08 108414 RK	MR	Multiple Residential	Single Family Res-Combo
08 108419 RK	MR	Multiple Residential	Single Family Res-Combo
08 108420 RK	MR	Multiple Residential	Single Family Res-Combo
08 103716 RK	R-5	Rural-5 Acre	Single Family Res-Combo
08 108410 RK	MR	Multiple Residential	Single Family Res-Combo
08 108412 RK	MR	Multiple Residential	Single Family Res-Combo
08 104174 RK	R-5	Rural-5 Acre	Single Family Res-Combo
08 104329 RK	R-5	Rural-5 Acre	Single Family Res-Combo
08 104448 RK	R-5	Rural-5 Acre	Single Family Res-Combo
08 106812 RK	R-7,200	Residential 7,200 sq. ft.	Single Family Res-Combo
08 108692 RK	R-7,200(PRD)	Residential 7,200 sq. ft.	SFR-Basic
08 109042 RK	R-7,200(PRD)	Residential 7,200 sq. ft.	SFR-Basic
08 105276 RK	R-5	Rural-5 Acre	Single Family Res-Combo
08 106350 RK	R-5	Rural-5 Acre	Single Family Res-Combo
08 106652 000 01 RK	LDMR	Low Density Multiple Reside	Single Family Res-Combo
08 107593 RK	R-7,200	Residential 7,200 sq. ft.	Single Family Res-Combo
08 107833 RK	R-5	Rural-5 Acre	Single Family Res-Combo
08 107837 RK	R-5	Rural-5 Acre	Single Family Res-Combo
08 107839 RK	R-5	Rural-5 Acre	Single Family Res-Combo
08 106894 RK	R-5	Rural-5 Acre	Single Family Res-Combo
08 111013 RK	R-7,200	Residential 7,200 sq. ft.	SFR-Basic
08 107894 MH	R-5	Rural-5 Acre	Double Wide
08 110038 RK	MR	Multiple Residential	Duplex-Combo

Accessory Dwelling Units

Index # - File Name: 1.0022 - Single Family Dwellings Data\_Snohomish County.pdf

08 110389 RK	MR	Multiple Residential	Single Family Res-Combo
08 110029 RK	MR	Multiple Residential	Single Family Res-Combo
08 110027 RK	MR	Multiple Residential	Single Family Res-Combo
08 110312 RK	MR	Multiple Residential	Single Family Res-Combo
08 110390 RK	MR	Multiple Residential	Single Family Res-Combo
08 107549 RK	CITY	City	SFR-Basic
08 102408 RK	R-7,200(PRD)	Residential 7,200 sq. ft.	SFR-Basic
08 110024 RK	R-7,200(PRD)	Residential 7,200 sq. ft.	SFR-Basic
08 102409 RK	R-7,200(PRD)	Residential 7,200 sq. ft.	SFR-Basic
08 102410 RK	R-7,200(PRD)	Residential 7,200 sq. ft.	SFR-Basic
07 115036 RK	R-5	Rural-5 Acre	Single Family Res-Combo
08 103225 RK	R-7,200	Residential 7,200 sq. ft.	Single Family Res-Combo
08 103242 RK	R-7,200	Residential 7,200 sq. ft.	Single Family Res-Combo
08 103316 RK	R-7,200	Residential 7,200 sq. ft.	SFR-Basic
08 105717 RK	R-7,200	Residential 7,200 sq. ft.	SFR-Basic
08 103318 RK	R-7,200	Residential 7,200 sq. ft.	SFR-Basic
08 105718 RK	R-7,200	Residential 7,200 sq. ft.	SFR-Basic
08 105719 RK	R-7,200	Residential 7,200 sq. ft.	SFR-Basic
07 108924 RK	R-5	Rural-5 Acre	Single Family Res-Combo
08 105877 RK	R-5	Rural-5 Acre	Single Family Res-Combo
08 110978 RK	R-7,200	Residential 7,200 sq. ft.	SFR-Basic
08 109968 RK	R-7,200	Residential 7,200 sq. ft.	Single Family Res-Combo
08 105876 RK	R-5	Rural-5 Acre	Single Family Res-Combo
08 104981 RK	R-5	Rural-5 Acre	Single Family Res-Combo
07 115110 RK	R-5	Rural-5 Acre	Single Family Res-Combo
08 109901 RK	R-7,200	Residential 7,200 sq. ft.	SFR-Basic
08 110979 RK	R-7,200	Residential 7,200 sq. ft.	SFR-Basic
07 114336 RK	LDMR	Low Density Multiple Reside	SFR-Basic
07 114339 RK	LDMR	Low Density Multiple Reside	SFR-Basic
07 114355 RK	LDMR	Low Density Multiple Reside	SFR-Basic
07 114354 RK	LDMR	Low Density Multiple Reside	SFR-Basic
07 114356 RK	LDMR	Low Density Multiple Reside	SFR-Basic
07 114341 RK	LDMR	Low Density Multiple Reside	SFR-Basic
07 114342 RK	LDMR	Low Density Multiple Reside	SFR-Basic
08 109896 RK	R-7,200	Residential 7,200 sq. ft.	SFR-Basic
08 109897 RK	R-7,200	Residential 7,200 sq. ft.	SFR-Basic
08 109898 RK	R-7,200	Residential 7,200 sq. ft.	SFR-Basic
08 109899 RK	R-7,200	Residential 7,200 sq. ft.	SFR-Basic
08 109904 RK	R-7,200	Residential 7,200 sq. ft.	SFR-Basic
08 101991 RK	CITY	City	SFR-Basic
08 107687 RK	R-5	Rural-5 Acre	Single Family Res-Combo
08 106591 RK	R-7,200	Residential 7,200 sq. ft.	SFR-Basic
08 102974 RK	R-7,200	Residential 7,200 sq. ft.	SFR-Basic
08 102078 RK	R-7,200	Residential 7,200 sq. ft.	Single Family Res-Combo
08 107843 RK	R-7,200	Residential 7,200 sq. ft.	SFR-Basic
08 105721 RK	R-7,200	Residential 7,200 sq. ft.	SFR-Basic
08 107842 RK	R-7,200	Residential 7,200 sq. ft.	SFR-Basic

Accessory Dwelling Units

Index # - File Name: 1.0022 - Single Family Dwellings Data\_Snohomish County.pdf

07 111816 RK	R-5	Rural-5 Acre	Single Family Res-Combo
07 111918 RK	R-5	Rural-5 Acre	Single Family Res-Combo
08 108250 RK	R-7,200	Residential 7,200 sq. ft.	SFR-Basic
08 104814 RK	LDMR	Low Density Multiple Reside	SFR-Basic
08 104815 RK	LDMR	Low Density Multiple Reside	SFR-Basic
08 104816 RK	LDMR	Low Density Multiple Reside	SFR-Basic
08 104817 RK	LDMR	Low Density Multiple Reside	SFR-Basic
08 103361 RK	LDMR	Low Density Multiple Reside	SFR-Basic
08 103362 RK	LDMR	Low Density Multiple Reside	SFR-Basic
08 103363 RK	LDMR	Low Density Multiple Reside	SFR-Basic
08 103366 RK	LDMR	Low Density Multiple Reside	SFR-Basic
08 103364 RK	LDMR	Low Density Multiple Reside	SFR-Basic
08 103365 RK	LDMR	Low Density Multiple Reside	SFR-Basic
08 105290 RK	LDMR	Low Density Multiple Reside	SFR-Basic
08 105285 RK	LDMR	Low Density Multiple Reside	SFR-Basic
08 105286 RK	LDMR	Low Density Multiple Reside	SFR-Basic
08 105287 RK	LDMR	Low Density Multiple Reside	SFR-Basic
08 105288 RK	LDMR	Low Density Multiple Reside	SFR-Basic
08 105289 RK	LDMR	Low Density Multiple Reside	SFR-Basic
08 107948 RK	R-5	Rural-5 Acre	Single Family Res-Combo
08 104248 RK	R-5	Rural-5 Acre	Single Family Res-Combo
08 105785 RK	R-5	Rural-5 Acre	Single Family Res-Combo
07 107842 RK	R-5	Rural-5 Acre	Single Family Res-Combo
08 101753 RK	RD	Rural Diversification	Single Family Res-Combo
08 106109 RK	R-5	Rural-5 Acre	Single Family Res-Combo
08 100912 RK	R-7,200	Residential 7,200 sq. ft.	SFR-Basic
08 100911 RK	R-7,200	Residential 7,200 sq. ft.	SFR-Basic
08 100905 RK	R-7,200	Residential 7,200 sq. ft.	SFR-Basic
08 109920 RK	CITY	City	SFR-Basic
08 104149 RK	CITY	City	SFR-Basic
07 114203 RK	CITY	City	Single Family Res-Combo
08 107898 RK	R-9,600	Residential 9,600 sq. ft.	SFR-Basic
08 100958 RK	UC	Urban Center	SFR-Basic
07 107913 RK	CITY	City	SFR-Basic
07 107914 RK	CITY	City	SFR-Basic
07 107918 RK	CITY	City	SFR-Basic
07 107915 RK	CITY	City	SFR-Basic
07 107916 RK	CITY	City	SFR-Basic
07 107917 RK	CITY	City	SFR-Basic
07 107924 RK	CITY	City	SFR-Basic
08 104150 RK	CITY	City	SFR-Basic
08 108981 RK	R-5	Rural-5 Acre	Single Family Res-Combo
08 110658 RK	R-5	Rural-5 Acre	Single Family Res-Combo
08 102788 RK	UC	Urban Center	SFR-Basic
08 100968 RK	UC	Urban Center	Single Family Res-Combo
08 101378 RK	UC	Urban Center	SFR-Basic
08 109173 RK	R-5	Rural-5 Acre	Single Family Res-Combo

Accessory Dwelling Units

Index # - File Name: 1.0022 - Single Family Dwellings Data\_Snohomish County.pdf

08 102972 RK	R-5	Rural-5 Acre	SFR-Basic
08 104440 RK	R-9,600	Residential 9,600 sq. ft.	SFR-Basic
08 105422 RK	R-9,600	Residential 9,600 sq. ft.	SFR-Basic
08 107714 RK	R-9,600	Residential 9,600 sq. ft.	SFR-Basic
08 106675 RK	R-9,600	Residential 9,600 sq. ft.	SFR-Basic
08 106674 RK	R-9,600	Residential 9,600 sq. ft.	SFR-Basic
08 110196 RK	R-9,600	Residential 9,600 sq. ft.	SFR-Basic
08 111232 RK	R-9,600	Residential 9,600 sq. ft.	SFR-Basic
08 105420 RK	R-9,600	Residential 9,600 sq. ft.	SFR-Basic
08 105421 RK	R-9,600	Residential 9,600 sq. ft.	SFR-Basic
08 101830 RK	R-9,600	Residential 9,600 sq. ft.	SFR-Basic
08 101831 RK	R-9,600	Residential 9,600 sq. ft.	SFR-Basic
08 104439 RK	R-9,600	Residential 9,600 sq. ft.	SFR-Basic
08 110860 RK	R-9,600	Residential 9,600 sq. ft.	SFR-Basic
08 101989 RK	R-9,600	Residential 9,600 sq. ft.	SFR-Basic
08 102279 RK	R-9,600	Residential 9,600 sq. ft.	SFR-Basic
08 109250 RK	R-9,600	Residential 9,600 sq. ft.	SFR-Basic
08 102278 RK	R-9,600	Residential 9,600 sq. ft.	SFR-Basic
08 103080 RK	R-9,600	Residential 9,600 sq. ft.	SFR-Basic
08 106599 RK	R-9,600	Residential 9,600 sq. ft.	SFR-Basic
08 108090 RK	R-9,600	Residential 9,600 sq. ft.	SFR-Basic
08 109249 RK	R-9,600	Residential 9,600 sq. ft.	SFR-Basic
08 107720 RK	R-9,600	Residential 9,600 sq. ft.	SFR-Basic
08 107721 RK	R-9,600	Residential 9,600 sq. ft.	SFR-Basic
08 104438 RK	R-9,600	Residential 9,600 sq. ft.	SFR-Basic
08 101832 RK	R-9,600	Residential 9,600 sq. ft.	SFR-Basic
08 101833 RK	R-9,600	Residential 9,600 sq. ft.	SFR-Basic
08 101834 RK	R-9,600	Residential 9,600 sq. ft.	SFR-Basic
08 101829 RK	R-9,600	Residential 9,600 sq. ft.	SFR-Basic
08 100980 RK	R-9,600	Residential 9,600 sq. ft.	SFR-Basic
08 105369 RK	R-7,200(PRD)	Residential 7,200 sq. ft.	SFR-Basic
07 112649 RK	R-7,200(PRD)	Residential 7,200 sq. ft.	SFR-Basic
08 105370 RK	R-7,200(PRD)	Residential 7,200 sq. ft.	SFR-Basic
07 112651 RK	R-7,200(PRD)	Residential 7,200 sq. ft.	SFR-Basic
07 113956 RK	R-7,200(PRD)	Residential 7,200 sq. ft.	SFR-Basic
07 113959 RK	R-7,200(PRD)	Residential 7,200 sq. ft.	SFR-Basic
07 113960 RK	R-7,200(PRD)	Residential 7,200 sq. ft.	SFR-Basic
07 113961 RK	R-7,200(PRD)	Residential 7,200 sq. ft.	SFR-Basic
08 102644 RK	R-5	Rural-5 Acre	Single Family Res-Combo
08 100092 RK	CITY	City	SFR-Basic
07 112402 RK	LDMR	Low Density Multiple Reside	Single Family Res-Combo
07 112408 RK	LDMR	Low Density Multiple Reside	Single Family Res-Combo
07 112400 RK	LDMR	Low Density Multiple Reside	Single Family Res-Combo
07 112409 RK	LDMR	Low Density Multiple Reside	Single Family Res-Combo
07 112398 RK	LDMR	Low Density Multiple Reside	Single Family Res-Combo
07 112399 RK	LDMR	Low Density Multiple Reside	Single Family Res-Combo
08 100413 RK	R-7,200(PRD)	Residential 7,200 sq. ft.	SFR-Basic

Accessory Dwelling Units

Index # - File Name: 1.0022 - Single Family Dwellings Data\_Snohomish County.pdf

08 100414 RK	R-7,200(PRD)	Residential 7,200 sq. ft.	SFR-Basic
08 100415 RK	R-7,200(PRD)	Residential 7,200 sq. ft.	SFR-Basic
08 100417 RK	R-7,200(PRD)	Residential 7,200 sq. ft.	SFR-Basic
07 113957 RK	R-7,200(PRD)	Residential 7,200 sq. ft.	SFR-Basic
08 100924 RK	CITY	City	SFR-Basic
08 100925 RK	CITY	City	SFR-Basic
08 100091 RK	CITY	City	SFR-Basic
08 103559 RK	CITY	City	SFR-Basic
08 102813 RK	CITY	City	SFR-Basic
07 114992 RK	R-7,200	Residential 7,200 sq. ft.	Single Family Res-Combo
08 102636 RK	LDMR	Low Density Multiple Reside	SFR-Basic
08 102637 RK	LDMR	Low Density Multiple Reside	SFR-Basic
08 102638 RK	LDMR	Low Density Multiple Reside	SFR-Basic
08 102639 RK	LDMR	Low Density Multiple Reside	SFR-Basic
08 102640 RK	LDMR	Low Density Multiple Reside	SFR-Basic
07 114982 RK	R-5	Rural-5 Acre	Single Family Res-Combo
08 100533 RK	R-5	Rural-5 Acre	Single Family Res-Combo
08 102199 RK	R-8,400	Residential 8,400 sq. ft.	Single Family Res-Combo
07 111633 RK	R-5	Rural-5 Acre	Single Family Res-Combo
08 102893 RK	R-5	Rural-5 Acre	Single Family Res-Combo
08 102864 RK	CITY	City	SFR-Basic
07 114822 RK	R-7,200	Residential 7,200 sq. ft.	Single Family Res-Combo
08 102726 RK	R-7,200(PRD)	Residential 7,200 sq. ft.	SFR-Basic
08 103445 RK	R-7,200(PRD)	Residential 7,200 sq. ft.	SFR-Basic
08 103446 RK	R-7,200(PRD)	Residential 7,200 sq. ft.	SFR-Basic
08 102725 RK	R-7,200(PRD)	Residential 7,200 sq. ft.	SFR-Basic
08 103447 RK	R-7,200(PRD)	Residential 7,200 sq. ft.	SFR-Basic
08 103295 RK	R-7,200(PRD)	Residential 7,200 sq. ft.	SFR-Basic
08 103443 RK	R-7,200(PRD)	Residential 7,200 sq. ft.	SFR-Basic
08 103444 RK	R-7,200(PRD)	Residential 7,200 sq. ft.	SFR-Basic
08 103296 RK	R-7,200(PRD)	Residential 7,200 sq. ft.	SFR-Basic
07 111360 RK	F	Forestry	Single Family Res-Combo
08 101359 RK	R-7,200	Residential 7,200 sq. ft.	Duplex-Combo
08 101341 RK	R-5	Rural-5 Acre	Single Family Res-Combo
08 109026 RK	MR	Multiple Residential	SFR-Basic
08 109027 RK	MR	Multiple Residential	SFR-Basic
08 109025 RK	MR	Multiple Residential	SFR-Basic
08 105305 RK	CITY	City	SFR-Basic
08 105304 RK	CITY	City	SFR-Basic
08 107265 RK	CITY	City	SFR-Basic
08 107809 RK	CITY	City	SFR-Basic
08 101985 RK	CITY	City	SFR-Basic
08 101984 RK	CITY	City	SFR-Basic
07 113864 RK	CITY	City	SFR-Basic
07 113866 RK	CITY	City	SFR-Basic
07 113867 RK	CITY	City	SFR-Basic
08 107425 MH	F and R ORV :	Forestry and Recreation-Off Double Wide	

Accessory Dwelling Units

Index # - File Name: 1.0022 - Single Family Dwellings Data\_Snohomish County.pdf

08 100504 RK	F	Forestry	SFR-Basic
08 108189 RK	CITY	City	SFR-Basic
08 107544 RK	CITY	City	SFR-Basic
07 112914 RK	R-5	Rural-5 Acre	Single Family Res-Combo
07 113775 RK	CITY	City	SFR-Basic
08 100478 RK	CITY	City	SFR-Basic
08 100479 RK	CITY	City	SFR-Basic
08 100480 RK	CITY	City	SFR-Basic
08 100481 RK	CITY	City	SFR-Basic
08 102949 RK	CITY	City	SFR-Basic
08 107810 RK	CITY	City	SFR-Basic
08 106155 RK	CITY	City	SFR-Basic
08 107264 RK	CITY	City	SFR-Basic
08 106156 RK	CITY	City	SFR-Basic
08 110914 RK	CITY	City	SFR-Basic
08 100989 RK	R-7,200	Residential 7,200 sq. ft.	SFR-Basic
08 100990 RK	R-7,200	Residential 7,200 sq. ft.	SFR-Basic
08 108194 RK	CITY	City	SFR-Basic
08 107545 RK	CITY	City	SFR-Basic
08 108190 RK	CITY	City	SFR-Basic
08 108191 RK	CITY	City	SFR-Basic
08 108192 RK	CITY	City	SFR-Basic
07 109321 RK	A-10	Agriculture-10 Acre	Single Family Res-Combo
08 102722 RK	R-7,200(PRD)	Residential 7,200 sq. ft.	SFR-Basic
08 107546 RK	CITY	City	SFR-Basic
08 108197 RK	CITY	City	SFR-Basic
08 107547 RK	CITY	City	SFR-Basic
08 107548 RK	CITY	City	SFR-Basic
08 103052 RK	R-9,600	Residential 9,600 sq. ft.	SFR-Basic
08 108015 MH	R-5	Rural-5 Acre	Double Wide
08 104937 MH	R-5	Rural-5 Acre	Double Wide
08 107119 MH	R-5	Rural-5 Acre	Triple Wide
08 100259 MH	R-5	Rural-5 Acre	Double Wide
08 102561 RK	RD	Rural Diversification	Single Family Res-Combo
08 105311 RK	R-5	Rural-5 Acre	SFR-Basic
08 110462 RK	R-9,600	Residential 9,600 sq. ft.	SFR-Basic
08 110463 RK	R-9,600	Residential 9,600 sq. ft.	SFR-Basic
08 109623 RK	R-5	Rural-5 Acre	Single Family Res-Combo
08 100893 RK	R-5	Rural-5 Acre	SFR-Basic
08 100894 RK	R-5	Rural-5 Acre	SFR-Basic
08 100891 RK	R-5	Rural-5 Acre	SFR-Basic
08 100892 RK	R-5	Rural-5 Acre	SFR-Basic
08 100897 RK	R-5	Rural-5 Acre	Single Family Res-Combo
08 102387 RK	R-5	Rural-5 Acre	SFR-Basic
08 104187 RK	R-5	Rural-5 Acre	SFR-Basic
08 107616 RK	R-5	Rural-5 Acre	Single Family Res-Combo
07 113441 RK	R-5	Rural-5 Acre	Single Family Res-Combo

Accessory Dwelling Units

Index # - File Name: 1.0022 - Single Family Dwellings Data\_Snohomish County.pdf

08 106610 RK	R-5	Rural-5 Acre	Single Family Res-Combo
08 100998 RK	R-7,200	Residential 7,200 sq. ft.	SFR-Basic
08 107899 RK	R-7,200	Residential 7,200 sq. ft.	SFR-Basic
08 107901 RK	R-7,200	Residential 7,200 sq. ft.	SFR-Basic
08 107902 RK	R-7,200	Residential 7,200 sq. ft.	SFR-Basic
08 105343 RK	R-5	Rural-5 Acre	SFR-Basic
08 110304 RK	R-5	Rural-5 Acre	Single Family Res-Combo
08 109502 RK	UC	Urban Center	Duplex-Basic
08 109505 RK	UC	Urban Center	Duplex-Basic
08 110485 RK	UC	Urban Center	Duplex-Basic
08 110486 RK	UC	Urban Center	Duplex-Basic
08 110487 RK	UC	Urban Center	Duplex-Basic
08 110484 RK	UC	Urban Center	Duplex-Basic
08 109503 RK	UC	Urban Center	Duplex-Basic
08 109504 RK	UC	Urban Center	Duplex-Basic
08 100648 RK	CITY	City	SFR-Basic
08 102765 RK	CITY	City	SFR-Basic
08 100649 RK	CITY	City	SFR-Basic
07 110394 RK	CITY	City	Single Family Res-Combo
08 100650 RK	CITY	City	SFR-Basic
08 107320 RK	CITY	City	SFR-Basic
08 107323 RK	CITY	City	SFR-Basic
08 107321 RK	CITY	City	SFR-Basic
08 100651 RK	CITY	City	SFR-Basic
08 100654 RK	CITY	City	SFR-Basic
08 100652 RK	CITY	City	SFR-Basic
08 100653 RK	CITY	City	SFR-Basic
07 114667 RK	R-5	Rural-5 Acre	Single Family Res-Combo
07 114675 MH	A-10	Agriculture-10 Acre	Double Wide
08 110194 RK			Duplex-Basic
08 101098 RK	R-7,200	Residential 7,200 sq. ft.	SFR-Basic
07 114787 RK	SA-1	Suburban Agriculture-1 Acre	Single Family Res-Combo
08 100280 RK	R-8,400	Residential 8,400 sq. ft.	SFR-Basic
08 100277 RK	R-8,400	Residential 8,400 sq. ft.	SFR-Basic
08 100278 RK	R-8,400	Residential 8,400 sq. ft.	SFR-Basic
08 100279 RK	R-8,400	Residential 8,400 sq. ft.	SFR-Basic
07 104014 RK	LDMR	Low Density Multiple Reside	SFR-Basic
08 100926 RK	RD	Rural Diversification	Single Family Res-Combo
08 109721 RK	R-7,200	Residential 7,200 sq. ft.	SFR-Basic
08 102327 RK	R-7,200	Residential 7,200 sq. ft.	SFR-Basic
08 100803 RK	R-7,200	Residential 7,200 sq. ft.	SFR-Basic
07 115120 RK	R-7,200	Residential 7,200 sq. ft.	SFR-Basic
08 100804 RK	R-7,200	Residential 7,200 sq. ft.	SFR-Basic
08 102334 RK	R-7,200	Residential 7,200 sq. ft.	SFR-Basic
07 115122 RK	R-7,200	Residential 7,200 sq. ft.	SFR-Basic
07 115123 RK	R-7,200	Residential 7,200 sq. ft.	SFR-Basic
08 104589 RK	R-7,200	Residential 7,200 sq. ft.	SFR-Basic

Accessory Dwelling Units

Index # - File Name: 1.0022 - Single Family Dwellings Data\_Snohomish County.pdf

07 114968 RK	R-7,200	Residential 7,200 sq. ft.	SFR-Basic
08 104146 RK	R-7,200	Residential 7,200 sq. ft.	SFR-Basic
08 102335 RK	R-7,200	Residential 7,200 sq. ft.	SFR-Basic
08 104147 RK	R-7,200	Residential 7,200 sq. ft.	SFR-Basic
08 104148 RK	R-7,200	Residential 7,200 sq. ft.	SFR-Basic
08 102325 RK	R-7,200	Residential 7,200 sq. ft.	SFR-Basic
08 102326 RK	R-7,200	Residential 7,200 sq. ft.	SFR-Basic
08 104142 RK	R-7,200	Residential 7,200 sq. ft.	SFR-Basic
08 104143 RK	R-7,200	Residential 7,200 sq. ft.	SFR-Basic
07 114965 RK	R-7,200	Residential 7,200 sq. ft.	SFR-Basic
07 114966 RK	R-7,200	Residential 7,200 sq. ft.	SFR-Basic
08 104144 RK	R-7,200	Residential 7,200 sq. ft.	SFR-Basic
08 104145 RK	R-7,200	Residential 7,200 sq. ft.	SFR-Basic
07 114967 RK	R-7,200	Residential 7,200 sq. ft.	SFR-Basic
08 103127 RK	R-7,200	Residential 7,200 sq. ft.	SFR-Basic
08 105629 RK	R-7,200	Residential 7,200 sq. ft.	SFR-Basic
08 100042 RK	R-7,200	Residential 7,200 sq. ft.	SFR-Basic
08 105865 RK	R-7,200	Residential 7,200 sq. ft.	SFR-Basic
08 102324 RK	R-7,200	Residential 7,200 sq. ft.	SFR-Basic
07 107089 RK	R-7,200	Residential 7,200 sq. ft.	SFR-Basic
08 104590 RK	R-7,200	Residential 7,200 sq. ft.	SFR-Basic
08 109684 RK	R-7,200	Residential 7,200 sq. ft.	SFR-Basic
07 107371 RK	R-7,200	Residential 7,200 sq. ft.	SFR-Basic
08 103875 RK	R-7,200	Residential 7,200 sq. ft.	SFR-Basic
08 109870 RK	R-7,200	Residential 7,200 sq. ft.	Single Family Res-Combo
07 114478 RK	R-5	Rural-5 Acre	Single Family Res-Combo
06 131322 000 01 RK	R-7,200	Residential 7,200 sq. ft.	Single Family Res-Combo
06 131323 000 01 RK	R-7,200	Residential 7,200 sq. ft.	Single Family Res-Combo
08 106723 RK	MR	Multiple Residential	SFR-Basic
08 106050 RK	MR	Multiple Residential	SFR-Basic
08 104501 RK	MR	Multiple Residential	SFR-Basic
08 105649 RK	MR	Multiple Residential	SFR-Basic
08 104953 RK	MR	Multiple Residential	SFR-Basic
08 106052 RK	MR	Multiple Residential	SFR-Basic
08 104954 RK	MR	Multiple Residential	SFR-Basic
08 105650 RK	MR	Multiple Residential	SFR-Basic
08 104500 RK	MR	Multiple Residential	SFR-Basic
08 108597 RK	R-7,200	Residential 7,200 sq. ft.	Single Family Res-Combo
08 100079 RK	F	Forestry	Single Family Res-Combo
06 127233 000 01 RK	R-5	Rural-5 Acre	Single Family Res-Combo
08 104947 RK	CITY	City	SFR-Basic
08 101087 RK	CITY	City	SFR-Basic
08 100616 RK	CITY	City	SFR-Basic
08 103248 RK	CITY	City	SFR-Basic
08 103249 RK	CITY	City	SFR-Basic
08 100617 RK	CITY	City	SFR-Basic
08 100818 RK	CITY	City	SFR-Basic



Accessory Dwelling Units

Index # - File Name: 1.0022 - Single Family Dwellings Data\_Snohomish County.pdf

08 102550 RK	CITY	City	SFR-Basic
08 101615 RK	CITY	City	SFR-Basic
08 102551 RK	CITY	City	SFR-Basic
08 100242 RK	CITY	City	SFR-Basic
08 100068 RK	CITY	City	SFR-Basic
08 104673 RK	CITY	City	SFR-Basic
08 103250 RK	CITY	City	SFR-Basic
08 102191 RK	CITY	City	SFR-Basic
06 130418 000 01 RK	PRD-9,600	Residential 9,600 sq. ft.	SFR-Basic
06 130419 000 01 RK	PRD-9,600	Residential 9,600 sq. ft.	SFR-Basic
06 127519 RK	R-5	Rural-5 Acre	Single Family Res-Combo
08 105990 RK	CITY	City	SFR-Basic
08 101290 RK	CITY	City	SFR-Basic
08 105039 RK	CITY	City	SFR-Basic
08 100482 RK	CITY	City	SFR-Basic
08 100483 RK	CITY	City	SFR-Basic
08 100477 RK	CITY	City	SFR-Basic
08 100308 RK	CITY	City	SFR-Basic
08 100309 RK	CITY	City	SFR-Basic
08 103079 RK	R-7,200(PRD)	Residential 7,200 sq. ft.	SFR-Basic
08 101715 RK	R-7,200(PRD)	Residential 7,200 sq. ft.	SFR-Basic
08 103579 RK	R-7,200(PRD)	Residential 7,200 sq. ft.	SFR-Basic
07 104865 RK	R-7,200(PRD)	Residential 7,200 sq. ft.	SFR-Basic
08 103580 RK	R-7,200(PRD)	Residential 7,200 sq. ft.	SFR-Basic
08 103581 RK	R-7,200(PRD)	Residential 7,200 sq. ft.	SFR-Basic
08 102913 RK	R-7,200(PRD)	Residential 7,200 sq. ft.	SFR-Basic
07 104867 RK	R-7,200(PRD)	Residential 7,200 sq. ft.	SFR-Basic
07 104874 RK	R-7,200(PRD)	Residential 7,200 sq. ft.	SFR-Basic
07 104862 RK	R-7,200(PRD)	Residential 7,200 sq. ft.	SFR-Basic
08 103578 RK	R-7,200(PRD)	Residential 7,200 sq. ft.	SFR-Basic
08 101266 MH	R-5	Rural-5 Acre	Double Wide
08 108307 RK	LDMR	Low Density Multiple Reside	SFR-Basic
08 109664 RK	LDMR	Low Density Multiple Reside	SFR-Basic
08 107702 MH	R-5	Rural-5 Acre	Double Wide
08 102552 RK	R-7,200	Residential 7,200 sq. ft.	SFR-Basic
08 104167 RK	R-7,200	Residential 7,200 sq. ft.	SFR-Basic
08 100615 RK	R-7,200	Residential 7,200 sq. ft.	SFR-Basic
08 100066 RK	R-7,200	Residential 7,200 sq. ft.	SFR-Basic
08 110514 RK	R-7,200	Residential 7,200 sq. ft.	SFR-Basic
08 102548 RK	R-7,200	Residential 7,200 sq. ft.	SFR-Basic
08 100241 RK	R-7,200	Residential 7,200 sq. ft.	SFR-Basic
08 103797 RK	R-7,200	Residential 7,200 sq. ft.	SFR-Basic
06 132577 000 01 RK	R-7,200(PRD)	Residential 7,200 sq. ft.	SFR-Basic
06 132979 000 01 RK	R-7,200(PRD)	Residential 7,200 sq. ft.	SFR-Basic
06 132583 000 01 RK	R-7,200(PRD)	Residential 7,200 sq. ft.	SFR-Basic
08 107126 RK	R-5	Rural-5 Acre	Single Family Res-Combo
06 132575 000 01 RK	R-7,200(PRD)	Residential 7,200 sq. ft.	SFR-Basic

Accessory Dwelling Units

Index # - File Name: 1.0022 - Single Family Dwellings Data\_Snohomish County.pdf

06 131130 RK	R-5	Rural-5 Acre	Single Family Res-Combo
06 131131 RK	R-5	Rural-5 Acre	Single Family Res-Combo
06 132576 000 01 RK	R-7,200(PRD)	Residential 7,200 sq. ft.	SFR-Basic
08 102061 RK	A-10 : R-5	Agriculture-10 Acre : Rural-5	Single Family Res-Combo
08 105778 RK	R-7,200(PRD)	Residential 7,200 sq. ft.	SFR-Basic
08 105779 RK	R-7,200(PRD)	Residential 7,200 sq. ft.	SFR-Basic
08 105780 RK	R-7,200(PRD)	Residential 7,200 sq. ft.	SFR-Basic
08 105781 RK	R-7,200(PRD)	Residential 7,200 sq. ft.	SFR-Basic
08 108126 RK	R-7,200(PRD)	Residential 7,200 sq. ft.	SFR-Basic
08 108127 RK	R-7,200(PRD)	Residential 7,200 sq. ft.	SFR-Basic
08 105216 RK	R-5	Rural-5 Acre	Single Family Res-Combo
08 108025 RK	R-7,200	Residential 7,200 sq. ft.	SFR-Basic
08 104056 RK	R-5	Rural-5 Acre	Single Family Res-Combo
08 109849 RK	R-5	Rural-5 Acre	Single Family Res-Combo
08 109802 RK	R-5	Rural-5 Acre	Single Family Res-Combo
07 110828 RK	R-7,200	Residential 7,200 sq. ft.	SFR-Basic
07 114942 RK	R-5	Rural-5 Acre	Single Family Res-Combo
07 114941 RK	R-5	Rural-5 Acre	Single Family Res-Combo
08 100070 RK	R-5	Rural-5 Acre	Single Family Res-Combo
08 104866 RK	R-7,200	Residential 7,200 sq. ft.	Single Family Res-Combo
08 105617 RK	CITY	City	SFR-Basic
08 105620 RK	CITY	City	SFR-Basic
08 103191 RK	CITY	City	SFR-Basic
07 107981 RK	MR	Multiple Residential	SFR-Basic
07 107985 RK	MR	Multiple Residential	SFR-Basic
07 107986 RK	MR	Multiple Residential	SFR-Basic
07 104945 RK	MR	Multiple Residential	SFR-Basic
08 103379 RK	R-7,200	Residential 7,200 sq. ft.	SFR-Basic
08 104945 RK	R-7,200	Residential 7,200 sq. ft.	SFR-Basic
07 107344 RK	R-7,200	Residential 7,200 sq. ft.	SFR-Basic
08 103380 RK	R-7,200	Residential 7,200 sq. ft.	SFR-Basic
08 107875 RK	R-7,200	Residential 7,200 sq. ft.	SFR-Basic
07 107798 RK	R-7,200	Residential 7,200 sq. ft.	SFR-Basic
08 105091 RK	R-5	Rural-5 Acre	Single Family Res-Combo
07 103010 RK	RC	Rural Conservation	Single Family Res-Combo
08 106379 RK	R-7,200	Residential 7,200 sq. ft.	Single Family Res-Combo
08 102113 RK	R-7,200	Residential 7,200 sq. ft.	SFR-Basic
08 103203 RK	R-9,600	Residential 9,600 sq. ft.	SFR-Basic
08 104393 RK	R-9,600	Residential 9,600 sq. ft.	Single Family Res-Combo
08 102980 RK	R-9,600	Residential 9,600 sq. ft.	SFR-Basic
08 102978 RK	R-9,600	Residential 9,600 sq. ft.	SFR-Basic
08 101710 RK	CITY	City	SFR-Basic
08 102979 RK	R-9,600	Residential 9,600 sq. ft.	SFR-Basic
08 110460 RK	CITY	City	SFR-Basic
08 101712 RK	CITY	City	SFR-Basic
08 101713 RK	CITY	City	SFR-Basic
08 101707 RK	CITY	City	SFR-Basic

Accessory Dwelling Units

Index # - File Name: 1.0022 - Single Family Dwellings Data\_Snohomish County.pdf

08 101704 RK	CITY	City	SFR-Basic
08 102990 RK	CITY	City	SFR-Basic
08 101322 RK	CITY	City	SFR-Basic
08 101706 RK	CITY	City	SFR-Basic
08 107209 RK	CITY	City	SFR-Basic
08 101111 RK	MR	Multiple Residential	SFR-Basic
08 101113 RK	MR	Multiple Residential	SFR-Basic
08 103593 RK	MR	Multiple Residential	SFR-Basic
08 101702 RK	CITY	City	SFR-Basic
08 103724 RK	MR	Multiple Residential	SFR-Basic
08 106010 RK	MR	Multiple Residential	SFR-Basic
08 103315 RK	MR	Multiple Residential	SFR-Basic
08 103725 RK	MR	Multiple Residential	SFR-Basic
08 101366 RK	MR	Multiple Residential	SFR-Basic
08 101365 RK	MR	Multiple Residential	SFR-Basic
08 107507 RK	MR	Multiple Residential	SFR-Basic
08 106009 RK	MR	Multiple Residential	SFR-Basic
08 108927 RK	MR	Multiple Residential	SFR-Basic
08 101112 RK	MR	Multiple Residential	SFR-Basic
08 105720 RK	MR	Multiple Residential	SFR-Basic
08 104545 RK	R-9,600	Residential 9,600 sq. ft.	Single Family Res-Combo
08 107420 RK	R-9,600	Residential 9,600 sq. ft.	SFR-Basic
08 104885 RK	R-9,600	Residential 9,600 sq. ft.	Single Family Res-Combo
08 106444 RK	F	Forestry	Single Family Res-Combo
08 108583 RK	R-7,200(PRD)	Residential 7,200 sq. ft.	SFR-Basic
08 100428 RK	R-7,200(PRD)	Residential 7,200 sq. ft.	SFR-Basic
08 100425 RK	R-7,200(PRD)	Residential 7,200 sq. ft.	SFR-Basic
08 100426 RK	R-7,200(PRD)	Residential 7,200 sq. ft.	SFR-Basic
08 100427 RK	R-7,200(PRD)	Residential 7,200 sq. ft.	SFR-Basic
07 115012 RK	R-5	Rural-5 Acre	Single Family Res-Combo
08 101813 RK	R-7,200(PRD)	Residential 7,200 sq. ft.	SFR-Basic
08 102814 RK	R-7,200(PRD)	Residential 7,200 sq. ft.	SFR-Basic
08 102815 RK	R-7,200(PRD)	Residential 7,200 sq. ft.	SFR-Basic
08 107759 RK	R-7,200(PRD)	Residential 7,200 sq. ft.	SFR-Basic
08 107600 RK	R-7,200(PRD)	Residential 7,200 sq. ft.	SFR-Basic
08 108453 RK	R-7,200(PRD)	Residential 7,200 sq. ft.	SFR-Basic
08 108454 RK	R-7,200(PRD)	Residential 7,200 sq. ft.	SFR-Basic
08 108460 RK	R-7,200(PRD)	Residential 7,200 sq. ft.	SFR-Basic
08 108455 RK	R-7,200(PRD)	Residential 7,200 sq. ft.	SFR-Basic
08 109188 RK	R-7,200(PRD)	Residential 7,200 sq. ft.	SFR-Basic
08 103677 RK	R-7,200	Residential 7,200 sq. ft.	SFR-Basic
08 103710 RK	R-7,200	Residential 7,200 sq. ft.	SFR-Basic
08 103711 RK	R-7,200	Residential 7,200 sq. ft.	SFR-Basic
08 103678 RK	R-7,200	Residential 7,200 sq. ft.	SFR-Basic
08 103679 RK	R-7,200	Residential 7,200 sq. ft.	SFR-Basic
08 103680 RK	R-7,200	Residential 7,200 sq. ft.	SFR-Basic
08 103564 RK	R-7,200	Residential 7,200 sq. ft.	SFR-Basic

Accessory Dwelling Units

Index # - File Name: 1.0022 - Single Family Dwellings Data\_Snohomish County.pdf

08 103565 RK	R-7,200	Residential 7,200 sq. ft.	SFR-Basic
08 103566 RK	R-7,200	Residential 7,200 sq. ft.	SFR-Basic
08 103459 RK	R-7,200	Residential 7,200 sq. ft.	SFR-Basic
08 103460 RK	R-7,200	Residential 7,200 sq. ft.	SFR-Basic
08 103461 RK	R-7,200	Residential 7,200 sq. ft.	SFR-Basic
08 103462 RK	R-7,200	Residential 7,200 sq. ft.	SFR-Basic
08 103463 RK	R-7,200	Residential 7,200 sq. ft.	SFR-Basic
08 101472 RK	R-7,200	Residential 7,200 sq. ft.	SFR-Basic
08 103567 RK	R-7,200	Residential 7,200 sq. ft.	SFR-Basic
08 103568 RK	R-7,200	Residential 7,200 sq. ft.	SFR-Basic
08 103681 RK	R-7,200	Residential 7,200 sq. ft.	SFR-Basic
08 101473 RK	R-7,200	Residential 7,200 sq. ft.	SFR-Basic
08 100400 RK	R-7,200	Residential 7,200 sq. ft.	SFR-Basic
08 100401 RK	R-7,200	Residential 7,200 sq. ft.	SFR-Basic
08 100402 RK	R-7,200	Residential 7,200 sq. ft.	SFR-Basic
08 100403 RK	R-7,200	Residential 7,200 sq. ft.	SFR-Basic
08 101345 RK	R-7,200	Residential 7,200 sq. ft.	SFR-Basic
08 104946 RK	R-7,200	Residential 7,200 sq. ft.	SFR-Basic
08 108441 RK	R-7,200	Residential 7,200 sq. ft.	SFR-Basic
08 103246 RK	R-7,200	Residential 7,200 sq. ft.	SFR-Basic
08 106540 RK	R-7,200	Residential 7,200 sq. ft.	SFR-Basic
08 100067 RK	R-7,200	Residential 7,200 sq. ft.	SFR-Basic
08 100455 RK	R-7,200	Residential 7,200 sq. ft.	SFR-Basic
08 102549 RK	R-7,200	Residential 7,200 sq. ft.	SFR-Basic
08 100398 RK	R-7,200	Residential 7,200 sq. ft.	SFR-Basic
08 104437 RK	R-7,200	Residential 7,200 sq. ft.	SFR-Basic
08 106738 RK	R-7,200	Residential 7,200 sq. ft.	SFR-Basic
08 105733 RK	R-7,200	Residential 7,200 sq. ft.	SFR-Basic
08 104436 RK	R-7,200	Residential 7,200 sq. ft.	SFR-Basic
08 101613 RK	R-7,200	Residential 7,200 sq. ft.	SFR-Basic
08 101084 RK	R-7,200	Residential 7,200 sq. ft.	SFR-Basic
08 101085 RK	R-7,200	Residential 7,200 sq. ft.	SFR-Basic
08 103451 RK	R-7,200	Residential 7,200 sq. ft.	SFR-Basic
08 103245 RK	R-7,200	Residential 7,200 sq. ft.	SFR-Basic
08 101346 RK	R-7,200	Residential 7,200 sq. ft.	SFR-Basic
08 103796 RK	R-7,200	Residential 7,200 sq. ft.	SFR-Basic
08 106493 RK	R-7,200	Residential 7,200 sq. ft.	SFR-Basic
08 107026 RK	R-9,600	Residential 9,600 sq. ft.	SFR-Basic
08 107024 RK	R-9,600	Residential 9,600 sq. ft.	SFR-Basic
08 105903 RK	R-5	Rural-5 Acre	Single Family Res-Combo
08 108450 RK	R-7,200(PRD)	Residential 7,200 sq. ft.	SFR-Basic
08 108451 RK	R-7,200(PRD)	Residential 7,200 sq. ft.	SFR-Basic
08 108452 RK	R-7,200(PRD)	Residential 7,200 sq. ft.	SFR-Basic
08 108461 RK	R-7,200(PRD)	Residential 7,200 sq. ft.	SFR-Basic
08 103112 RK	R-7,200(PRD)	Residential 7,200 sq. ft.	SFR-Basic
08 102817 RK	R-7,200(PRD)	Residential 7,200 sq. ft.	SFR-Basic
08 110034 RK	MR	Multiple Residential	Duplex-Combo

Accessory Dwelling Units

Index # - File Name: 1.0022 - Single Family Dwellings Data\_Snohomish County.pdf

08 110033 RK	MR	Multiple Residential	Duplex-Combo
08 103835 RK	MR	Multiple Residential	Single Family Res-Combo
08 100339 RK	MR	Multiple Residential	Single Family Res-Combo
08 100336 RK	MR	Multiple Residential	Single Family Res-Combo
08 103712 RK	MR	Multiple Residential	Single Family Res-Combo
08 100442 RK	R-7,200	Residential 7,200 sq. ft.	SFR-Basic
08 109492 RK	R-7,200	Residential 7,200 sq. ft.	SFR-Basic
08 102778 RK	R-7,200	Residential 7,200 sq. ft.	SFR-Basic
08 106287 RK	R-7,200	Residential 7,200 sq. ft.	SFR-Basic
08 106494 RK	R-7,200	Residential 7,200 sq. ft.	SFR-Basic
08 101381 RK	R-7,200	Residential 7,200 sq. ft.	Single Family Res-Combo
08 100843 RK	R-7,200	Residential 7,200 sq. ft.	Single Family Res-Combo
07 114240 RK	R-5	Rural-5 Acre	Single Family Res-Combo
07 107133 RK	R-7,200	Residential 7,200 sq. ft.	Duplex-Combo
07 107134 RK	R-7,200	Residential 7,200 sq. ft.	Duplex-Combo
08 100690 RK	R-7,200	Residential 7,200 sq. ft.	SFR-Basic
06 133788 000 01 RK	R-5	Rural-5 Acre	SFR-Basic
07 112607 RK	F	Forestry	Single Family Res-Combo
08 109183 RK	RRT-10	Rural Resource Transition-10	Single Family Res-Combo
08 100189 RK	CITY	City	SFR-Basic
08 100190 RK	CITY	City	SFR-Basic
08 100191 RK	CITY	City	SFR-Basic
08 100192 RK	CITY	City	SFR-Basic
08 100193 RK	CITY	City	SFR-Basic
08 100194 RK	CITY	City	SFR-Basic
08 100196 RK	CITY	City	SFR-Basic
08 100197 RK	CITY	City	SFR-Basic
08 100198 RK	CITY	City	SFR-Basic
08 100199 RK	CITY	City	SFR-Basic
08 100195 RK	CITY	City	SFR-Basic
08 100200 RK	CITY	City	SFR-Basic
08 100201 RK	CITY	City	SFR-Basic
08 100202 RK	CITY	City	SFR-Basic
08 100203 RK	CITY	City	SFR-Basic
08 105215 RK	R-5	Rural-5 Acre	Accessory Apt Detached-Combo
08 104464 RK	R-5	Rural-5 Acre	Single Family Res-Combo
07 111489 RK	F	Forestry	Single Family Res-Combo
06 134161 000 01 RK	F	Forestry	Single Family Res-Combo
07 114276 MH	F : RC	Forestry : Rural Conservation	Triple Wide
07 107549 RK	MR	Multiple Residential	SFR-Basic
07 108036 RK	MR	Multiple Residential	SFR-Basic
07 108038 RK	MR	Multiple Residential	SFR-Basic
07 107607 RK	MR	Multiple Residential	SFR-Basic
07 108039 RK	MR	Multiple Residential	SFR-Basic
07 107608 RK	MR	Multiple Residential	SFR-Basic
07 114371 RK	R-5	Rural-5 Acre	Single Family Res-Combo
07 108045 RK	MR	Multiple Residential	Single Family Res-Combo

Accessory Dwelling Units

Index # - File Name: 1.0022 - Single Family Dwellings Data\_Snohomish County.pdf

07 114193 RK	R-5 : R-7,200	Residential 7,200 sq. ft. : Ru	SFR-Basic
07 114187 RK	R-5 : R-7,200	Residential 7,200 sq. ft. : Ru	SFR-Basic
08 103355 RK	R-5	Rural-5 Acre	SFR-Basic
07 107497 RK	MR	Multiple Residential	SFR-Basic
07 114190 RK	R-5 : R-7,200	Residential 7,200 sq. ft. : Ru	SFR-Basic
08 110182 RK	CITY	City	SFR-Basic
08 102190 RK	CITY	City	SFR-Basic
08 103244 RK	CITY	City	SFR-Basic
08 102276 RK	R-5	Rural-5 Acre	Single Family Res-Combo
08 104672 RK	CITY	City	SFR-Basic
08 101914 RK	CITY	City	SFR-Basic
08 101612 RK	CITY	City	SFR-Basic
08 101083 RK	CITY	City	SFR-Basic
08 104166 RK	CITY	City	SFR-Basic
08 108442 RK	CITY	City	SFR-Basic
08 103157 RK	R-7,200	Residential 7,200 sq. ft.	SFR-Basic
08 101616 RK	R-9,600	Residential 9,600 sq. ft.	SFR-Basic
08 100618 RK	R-9,600	Residential 9,600 sq. ft.	SFR-Basic
08 101082 RK	R-9,600	Residential 9,600 sq. ft.	SFR-Basic
08 101610 RK	R-9,600	Residential 9,600 sq. ft.	SFR-Basic
08 101611 RK	R-9,600	Residential 9,600 sq. ft.	SFR-Basic
08 101088 RK	R-9,600	Residential 9,600 sq. ft.	SFR-Basic
08 102188 RK	R-9,600	Residential 9,600 sq. ft.	SFR-Basic
08 102192 RK	R-9,600	Residential 9,600 sq. ft.	SFR-Basic
08 100820 RK	R-9,600	Residential 9,600 sq. ft.	SFR-Basic
08 102189 RK	R-9,600	Residential 9,600 sq. ft.	SFR-Basic
08 100821 RK	R-9,600	Residential 9,600 sq. ft.	SFR-Basic
08 100064 RK	R-9,600	Residential 9,600 sq. ft.	SFR-Basic
08 105904 RK	R-5	Rural-5 Acre	Single Family Res-Combo
06 133278 000 01 RK	RRT-10	Rural Resource Transition-1	(Single Family Res-Combo
06 134145 000 01 RK	RRT-10	Rural Resource Transition-1	(Single Family Res-Combo
06 129769 000 01 RK	RRT-10	Rural Resource Transition-1	(Single Family Res-Combo
08 106909 RK	RRT-10	Rural Resource Transition-1	(Single Family Res-Combo
08 100705 RK	RRT-10	Rural Resource Transition-1	(Single Family Res-Combo
08 111094 RK	RRT-10	Rural Resource Transition-1	(Single Family Res-Combo
08 107723 RK	R-5	Rural-5 Acre	Single Family Res-Combo
08 106084 RK	R-5	Rural-5 Acre	Single Family Res-Combo
07 111025 RK	R-5	Rural-5 Acre	Single Family Res-Combo
08 100078 RK	R-5	Rural-5 Acre	Single Family Res-Combo
08 105480 RK	A-10	Agriculture-10 Acre	Single Family Res-Combo
08 105396 RK	R-5	Rural-5 Acre	Single Family Res-Combo
08 103083 RK	R-5	Rural-5 Acre	Single Family Res-Combo
07 109707 MH	R-5	Rural-5 Acre	Double Wide
08 101973 RK	RRT-10	Rural Resource Transition-1	(Single Family Res-Combo
08 105253 RK	R-5	Rural-5 Acre	Single Family Res-Combo
08 102486 RK	R-5	Rural-5 Acre	Single Family Res-Combo
05 127309 000 01 RK	R-5	Rural-5 Acre	Single Family Res-Combo

Accessory Dwelling Units

Index # - File Name: 1.0022 - Single Family Dwellings Data\_Snohomish County.pdf

06 102819 000 01 RK	R-5	Rural-5 Acre	Single Family Res-Combo
06 126785 000 01 RK	R-9,600	Residential 9,600 sq. ft.	Single Family Res-Combo
08 100343 RK	R-9,600(PRD)	Residential 9,600 sq. ft.	Single Family Res-Combo
08 102625 MH	A-10	Agriculture-10 Acre	Double Wide
06 133791 000 01 RK	R-5	Rural-5 Acre	SFR-Basic
08 104320 RK	R-5	Rural-5 Acre	Single Family Res-Combo
07 106559 RK	PRD-20,000	Residential 20,000 sq. ft.	Single Family Res-Combo
07 103868 RK	PRD-20,000	Residential 20,000 sq. ft.	SFR-Basic
08 106501 RK	R-5	Rural-5 Acre	Single Family Res-Combo
08 106506 RK	R-7,200	Residential 7,200 sq. ft.	Single Family Res-Combo
08 103150 RK	R-7,200	Residential 7,200 sq. ft.	SFR-Basic
08 107225 RK	R-7,200	Residential 7,200 sq. ft.	SFR-Basic
08 104812 RK	R-7,200	Residential 7,200 sq. ft.	SFR-Basic
08 104294 RK	RD	Rural Diversification	SFR-Basic
06 103766 000 01 RK	R-5	Rural-5 Acre	Single Family Res-Combo
08 102399 RK	CITY	City	Single Family Res-Combo
07 115131 RK	R-5	Rural-5 Acre	Single Family Res-Combo
06 125016 000 01 RK	R-5	Rural-5 Acre	Single Family Res-Combo
08 106263 RK	R-5	Rural-5 Acre	Single Family Res-Combo
06 101183 000 01 RK	R-5	Rural-5 Acre	Single Family Res-Combo
08 103145 RK	R-5	Rural-5 Acre	Single Family Res-Combo
08 103177 RK	R-5	Rural-5 Acre	Single Family Res-Combo
05 124657 000 01 RK	R-5	Rural-5 Acre	Single Family Res-Combo
07 103812 RK	A-10	Agriculture-10 Acre	Single Family Res-Combo
07 108505 RK	F	Forestry	Single Family Res-Combo
08 108771 RK	R-9,600	Residential 9,600 sq. ft.	Single Family Res-Combo
08 111441 RK	R-5	Rural-5 Acre	Single Family Res-Combo
08 105036 RK	R-5	Rural-5 Acre	Single Family Res-Combo
08 105923 MH	MHP	Mobile Home Park	MH Park-Double Wide
08 104693 RK	R-5	Rural-5 Acre	Single Family Res-Combo
08 102962 RK	R-5	Rural-5 Acre	Single Family Res-Combo
07 114098 RK	R-5	Rural-5 Acre	Single Family Res-Combo
08 103323 RK	R-5	Rural-5 Acre	Single Family Res-Combo
08 108757 RK	R-5	Rural-5 Acre	Single Family Res-Combo
08 101282 RK	R-5	Rural-5 Acre	Single Family Res-Combo
07 114153 RK	R-5	Rural-5 Acre	Single Family Res-Combo
07 111427 RK	R-5	Rural-5 Acre	Single Family Res-Combo
08 108415 RK	R-5	Rural-5 Acre	Single Family Res-Combo
08 107753 MH	R-5	Rural-5 Acre	Double Wide
08 104089 RK	LDMR	Low Density Multiple Reside	Single Family Res-Combo
08 105244 MH	R-5	Rural-5 Acre	Double Wide
08 105395 RK	RC	Rural Conservation	Single Family Res-Combo
08 106037 MH	R-5	Rural-5 Acre	Double Wide
08 104743 000 01 RK	R-5	Rural-5 Acre	Single Family Res-Combo
07 114180 MH	F	Forestry	Double Wide
07 103302 RK	R-9,600	Residential 9,600 sq. ft.	Single Family Res-Combo
08 104094 RK	R-5	Rural-5 Acre	Single Family Res-Combo

Accessory Dwelling Units

Index # - File Name: 1.0022 - Single Family Dwellings Data\_Snohomish County.pdf

08 106835 RK	R-5	Rural-5 Acre	Single Family Res-Combo
07 111621 RK	R-5	Rural-5 Acre	Single Family Res-Combo
08 105573 RK	PRD SA-1 : R-5	Rural-5 Acre : Suburban Agri	Single Family Res-Combo
07 112896 RK	R-5	Rural-5 Acre	Single Family Res-Combo
08 105799 RK	R-5	Rural-5 Acre	Single Family Res-Combo
08 109078 RK	R-7,200	Residential 7,200 sq. ft.	Single Family Res-Combo
07 106250 RK	F	Forestry	Single Family Res-Combo
06 126273 000 01 RK	R-5	Rural-5 Acre	Single Family Res-Combo
08 101393 RK	R-5	Rural-5 Acre	Single Family Res-Combo
08 107167 RK	R-5	Rural-5 Acre	Single Family Res-Combo
06 127491 000 01 RK	R-5	Rural-5 Acre	Single Family Res-Combo
08 102692 RK	R-5	Rural-5 Acre	Single Family Res-Combo
07 109913 RK	R-5	Rural-5 Acre	Single Family Res-Combo
08 105867 RK	R-5	Rural-5 Acre	Single Family Res-Combo
08 100461 RK	PRD-20,000(M	Residential 20,000 sq. ft.	Single Family Res-Combo
07 112759 RK	PRD-20,000(M	Residential 20,000 sq. ft.	Single Family Res-Combo
08 101406 RK	LDMR	Low Density Multiple Reside	Single Family Res-Combo
08 105245 RK	R-5	Rural-5 Acre	Single Family Res-Combo
08 101103 RK	F	Forestry	Single Family Res-Combo
07 111586 MH	F	Forestry	Double Wide
08 101397 RK	R-5	Rural-5 Acre	Single Family Res-Combo
07 112218 RK	R-5	Rural-5 Acre	SFR-Basic
08 105537 RK	WFB	Waterfront Beach	Single Family Res-Combo
08 106556 RK	R-7,200	Residential 7,200 sq. ft.	Single Family Res-Combo
08 106107 RK	R-7,200	Residential 7,200 sq. ft.	Duplex-Basic
08 102740 RK	F	Forestry	Single Family Res-Combo
07 111443 RK	F	Forestry	Single Family Res-Combo
08 106552 RK	LDMR	Low Density Multiple Reside	Duplex-Basic
08 106615 RK	R-8,400	Residential 8,400 sq. ft.	Single Family Res-Combo
08 103690 RK	R-5	Rural-5 Acre	Single Family Res-Combo
08 103836 RK	R-5	Rural-5 Acre	Single Family Res-Combo
07 114635 RK	R-5	Rural-5 Acre	Single Family Res-Combo
07 111040 RK	R-5	Rural-5 Acre	Single Family Res-Combo
08 101287 RK	A-10	Agriculture-10 Acre	Single Family Res-Combo
08 104800 RK	R-5	Rural-5 Acre	Single Family Res-Combo
07 110923 RK	R-5	Rural-5 Acre	Single Family Res-Combo
06 128621 000 01 RK	R-5	Rural-5 Acre	Single Family Res-Combo
08 103354 RK	R-5	Rural-5 Acre	Accessory Apt Detached-Combo
08 103137 RK	R-5	Rural-5 Acre	Single Family Res-Combo
06 129903 RK	R-5	Rural-5 Acre	Single Family Res-Combo
08 109148 MH	R-5	Rural-5 Acre	Double Wide
08 105948 MH	R-5	Rural-5 Acre	Single Wide
05 126767 000 01 RK	R-5	Rural-5 Acre	Single Family Res-Combo
07 113876 RK	R-5	Rural-5 Acre	Single Family Res-Combo
08 102476 RK	R-5	Rural-5 Acre	SFR-Basic
08 109101 RK	R-7,200(PRD)	Residential 7,200 sq. ft.	Duplex-Combo
07 112030 RK	R-5	Rural-5 Acre	Single Family Res-Combo



Accessory Dwelling Units

Index # - File Name: 1.0022 - Single Family Dwellings Data\_Snohomish County.pdf

08 100496 RK	R-5	Rural-5 Acre	Single Family Res-Combo
08 109501 RK	R-5	Rural-5 Acre	Single Family Res-Combo
07 111458 RK	R-5	Rural-5 Acre	Single Family Res-Combo
08 107588 RK	R-5	Rural-5 Acre	Single Family Res-Combo
08 106880 RK	R-5	Rural-5 Acre	Single Family Res-Combo
07 110772 RK	R-5	Rural-5 Acre	Single Family Res-Combo
08 101487 RK	R-5	Rural-5 Acre	Single Family Res-Combo
07 114433 RK	R-9,600	Residential 9,600 sq. ft.	Single Family Res-Combo
07 112922 RK	R-5	Rural-5 Acre	Single Family Res-Combo
08 100680 RK	F	Forestry	Single Family Res-Combo
08 107591 RK	F	Forestry	Single Family Res-Combo
05 128357 RK	WFB	Waterfront Beach	Single Family Res-Combo
08 107969 RK	LDMR	Low Density Multiple Reside	Duplex-Combo
07 114659 RK	R-8,400	Residential 8,400 sq. ft.	Single Family Res-Combo
08 105577 RK	R-7,200	Residential 7,200 sq. ft.	Duplex-Basic
08 107078 RK	R-7,200	Residential 7,200 sq. ft.	Duplex-Combo
07 109924 RK	R-7,200	Residential 7,200 sq. ft.	Duplex-Combo
08 101403 RK	R-7,200	Residential 7,200 sq. ft.	Single Family Res-Combo
07 110687 RK	WFB	Waterfront Beach	Single Family Res-Combo
06 126753 000 01 RK	A-10 : R-5	Agriculture-10 Acre : Rural-5	Single Family Res-Combo
06 136127 RK	R-5	Rural-5 Acre	Single Family Res-Combo
06 102303 000 01 RK	R-5	Rural-5 Acre	Single Family Res-Combo
08 102729 RK	R-5	Rural-5 Acre	Single Family Res-Combo
08 103668 MH	CITY	City	Triple Wide
08 104290 RK	R-5	Rural-5 Acre	Single Family Res-Combo
08 100895 MH	R-5	Rural-5 Acre	Double Wide
08 107342 RK	R-5	Rural-5 Acre	Single Family Res-Combo
08 104164 RK	R-5	Rural-5 Acre	Single Family Res-Combo
08 102998 RK	R-5	Rural-5 Acre	Single Family Res-Combo
08 102566 RK	CITY	City	Duplex-Basic
08 102319 RK	CITY	City	Single Family Res-Combo
08 110281 MH	R-5	Rural-5 Acre	Triple Wide
08 107147 MH	R-5	Rural-5 Acre	Double Wide
08 107408 MH	R-5	Rural-5 Acre	Triple Wide
07 114657 RK	R-5	Rural-5 Acre	Single Family Res-Combo
08 107066 RK	R-5	Rural-5 Acre	Single Family Res-Combo
08 102663 RK	CITY	City	Single Family Res-Combo
07 111542 MH	R-5	Rural-5 Acre	Triple Wide
08 106966 RK	R-5	Rural-5 Acre	Single Family Res-Combo
08 106225 RK	CITY	City	Single Family Res-Combo
08 107310 RK	R-5	Rural-5 Acre	Single Family Res-Combo
07 114856 RK	RRT-10	Rural Resource Transition-10	Single Family Res-Combo
08 105374 RK	R-5 : SA-1	Rural-5 Acre : Suburban Agri	Duplex-Combo
05 125169 000 02 RK	R-5	Rural-5 Acre	Single Family Res-Combo
07 111382 RK	R-5	Rural-5 Acre	Single Family Res-Combo
07 108423 RK	R-5	Rural-5 Acre	Single Family Res-Combo
07 111373 RK	R-5	Rural-5 Acre	Single Family Res-Combo

Accessory Dwelling Units

Index # - File Name: 1.0022 - Single Family Dwellings Data\_Snohomish County.pdf

08 105786 MH	R-5	Rural-5 Acre	Double Wide
06 131129 RK	R-5	Rural-5 Acre	Single Family Res-Combo
07 102025 RK	R-5	Rural-5 Acre	Single Family Res-Combo
07 102027 RK	R-5	Rural-5 Acre	Single Family Res-Combo
07 107004 RK	RRT-10	Rural Resource Transition-10	Single Family Res-Combo
08 110289 RK	R-5	Rural-5 Acre	Single Family Res-Combo
08 100305 RK	R-5	Rural-5 Acre	Single Family Res-Combo
08 105341 RK	CITY	City	Single Family Res-Combo
07 114784 RK	SA-1	Suburban Agriculture-1 Acre	Single Family Res-Combo
08 104611 RK	R-5	Rural-5 Acre	Single Family Res-Combo
07 108028 RK	R-5	Rural-5 Acre	Single Family Res-Combo
08 104072 RK	R-5	Rural-5 Acre	Single Family Res-Combo
08 104071 RK	R-5	Rural-5 Acre	Single Family Res-Combo
08 102286 RK	R-5	Rural-5 Acre	Duplex-Combo
07 111506 RK	A-10	Agriculture-10 Acre	Single Family Res-Combo
08 103074 RK	R-5	Rural-5 Acre	Single Family Res-Combo
06 135719 RK	R-5	Rural-5 Acre	Single Family Res-Combo
08 110575 RK	A-10	Agriculture-10 Acre	Single Family Res-Combo
08 105439 RK	R-5	Rural-5 Acre	Single Family Res-Combo
07 113558 RK	R-5	Rural-5 Acre	Single Family Res-Combo
08 110332 MH	R-5	Rural-5 Acre	Double Wide
07 108167 RK	R-5	Rural-5 Acre	Single Family Res-Combo
08 105449 RK	R-5	Rural-5 Acre	Single Family Res-Combo
07 111048 RK	R-5	Rural-5 Acre	Single Family Res-Combo
07 114995 RK	R-5	Rural-5 Acre	Single Family Res-Combo
08 106722 RK	R-5	Rural-5 Acre	Single Family Res-Combo
07 114454 RK	R-5	Rural-5 Acre	Single Family Res-Combo
06 134616 RK	R-5	Rural-5 Acre	Single Family Res-Combo
08 111075 MH	R-5	Rural-5 Acre	Double Wide
08 109259 RK	R-5	Rural-5 Acre	Single Family Res-Combo
07 114650 RK	R-5	Rural-5 Acre	Single Family Res-Combo
06 134033 000 01 RK	R-5	Rural-5 Acre	Single Family Res-Combo
08 104803 RK	R-5	Rural-5 Acre	Single Family Res-Combo
08 109306 RK	R-5	Rural-5 Acre	Single Family Res-Combo
08 103514 RK	RD	Rural Diversification	Single Family Res-Combo
07 114366 RK	R-5	Rural-5 Acre	Single Family Res-Combo
08 107201 RK	R-5	Rural-5 Acre	Single Family Res-Combo
08 110380 RK	R-5	Rural-5 Acre	Single Family Res-Combo
08 103911 RK	R-5	Rural-5 Acre	Single Family Res-Combo
07 113437 RK	R-5	Rural-5 Acre	Single Family Res-Combo
08 104036 RK	R-5	Rural-5 Acre	Single Family Res-Combo
06 129037 000 01 RK	R-5	Rural-5 Acre	Single Family Res-Combo
07 107336 RK	R-5	Rural-5 Acre	Single Family Res-Combo
08 101307 RK	R-5	Rural-5 Acre	Single Family Res-Combo
08 102309 RK	R-5	Rural-5 Acre	SFR-Basic
08 107992 RK	R-5	Rural-5 Acre	Single Family Res-Combo
08 110772 RK	R-5	Rural-5 Acre	Single Family Res-Combo

Accessory Dwelling Units

Index # - File Name: 1.0022 - Single Family Dwellings Data\_Snohomish County.pdf

08 106740 RK	R-5	Rural-5 Acre	Single Family Res-Combo
08 107396 RK	R-5	Rural-5 Acre	Single Family Res-Combo
07 101169 RK	R-5	Rural-5 Acre	Single Family Res-Combo
08 102682 MH	RD	Rural Diversification	Double Wide
08 108504 RK	R-5	Rural-5 Acre	Single Family Res-Combo
08 104692 MH	A-10	Agriculture-10 Acre	Double Wide
08 102378 RK	R-5	Rural-5 Acre	Single Family Res-Combo
08 105969 RK	R-5	Rural-5 Acre	Single Family Res-Combo
07 107974 RK	F	Forestry	Single Family Res-Combo
07 108507 RK	R-5	Rural-5 Acre	Single Family Res-Combo
06 104248 000 01 RK	R-5	Rural-5 Acre	Single Family Res-Combo
08 105839 000 01 RK	R-5	Rural-5 Acre	Single Family Res-Combo
08 104338 RK	R-5	Rural-5 Acre	Single Family Res-Combo
08 108131 RK	R-5	Rural-5 Acre	Single Family Res-Combo
06 126870 000 01 RK	PRD-20,000	Residential 20,000 sq. ft.	Single Family Res-Combo
09 105653 RK	CITY	City	Single Family Residential
06 133652 000 01 RK	R-5	Rural-5 Acre	Single Family Res-Combo
08 107941 RK	R-5	Rural-5 Acre	Single Family Res-Combo
09 103747 RK	R-5	Rural-5 Acre	Single Family Residential
09 106387 RK	R-5	Rural-5 Acre	Single Family Residential
06 126969 000 01 RK	CITY	City	Single Family Res-Combo
09 104231 RK	R-5	Rural-5 Acre	Single Family Residential
08 109742 RK	CITY	City	Single Family Res-Combo
08 107043 RK	R-5	Rural-5 Acre	Single Family Res-Combo
09 105878 RK	R-5	Rural-5 Acre	Single Family Residential
09 101151 RK	R-5	Rural-5 Acre	Single Family Res-Combo
07 111011 RK	A-10	Agriculture-10 Acre	Single Family Res-Combo
07 112439 MH	RD	Rural Diversification	Double Wide
08 109759 RK	R-5	Rural-5 Acre	Single Family Res-Combo
09 104818 RK	R-5	Rural-5 Acre	Single Family Residential
08 109599 RK	RRT-10	Rural Resource Transition-10	Single Family Res-Combo
08 111408 MH	A-10	Agriculture-10 Acre	Triple Wide
09 101126 RK	R-5	Rural-5 Acre	Single Family Res-Combo
08 103464 000 01 MH	R-5	Rural-5 Acre	Triple Wide
07 105300 000 01 RK	R-5	Rural-5 Acre	Single Family Res-Combo
09 105624 RK	R-5	Rural-5 Acre	Accessory Apt Detached
09 102737 RK	R-5	Rural-5 Acre	Single Family Res-Combo
08 110636 RK	R-5	Rural-5 Acre	Single Family Res-Combo
09 104148 RK	RD	Rural Diversification	Single Family Residential
09 106126 MH	R-5	Rural-5 Acre	Triple Wide
08 105694 000 01 MH	R-5	Rural-5 Acre	Triple Wide
08 110864 MH	A-10	Agriculture-10 Acre	Double Wide
09 103013 RK	R-5	Rural-5 Acre	Single Family Res-Combo
09 107481 RK	R-5	Rural-5 Acre	Single Family Residential
09 100232 RK	R-5	Rural-5 Acre	Accessory Apt Detached-Combo
09 103885 RK	R-5	Rural-5 Acre	Single Family Residential
09 105154 RK	F	Forestry	Single Family Residential

Accessory Dwelling Units

Index # - File Name: 1.0022 - Single Family Dwellings Data\_Snohomish County.pdf

09 105400 RK	R-5	Rural-5 Acre	Single Family Residential
06 131985 000 01 RK	R-5	Rural-5 Acre	Accessory Apt Detached-Combo
08 107322 RK	R-5	Rural-5 Acre	Single Family Res-Combo
08 110781 RK	R-5	Rural-5 Acre	Single Family Res-Combo
09 104450 RK	R-5	Rural-5 Acre	Single Family Residential
09 101261 MH	R-5	Rural-5 Acre	Double Wide
09 106629 RK	R-5	Rural-5 Acre	Single Family Residential
09 102196 RK	R-5	Rural-5 Acre	Accessory Apt Detached-Combo
08 106306 MH	R-5	Rural-5 Acre	Double Wide
09 103207 RK	R-5	Rural-5 Acre	Single Family Res-Combo
09 100491 RK	R-5	Rural-5 Acre	Single Family Res-Combo
09 100152 RK	R-5	Rural-5 Acre	Single Family Res-Combo
08 108230 RK	R-5	Rural-5 Acre	Single Family Res-Combo
09 100796 RK	R-5	Rural-5 Acre	Single Family Res-Combo
09 103527 RK	R-5	Rural-5 Acre	Single Family Res-Combo
07 111292 RK	RRT-10	Rural Resource Transition-10	Single Family Res-Combo
09 106483 RK	R-5	Rural-5 Acre	Single Family Residential
06 133099 000 02 RK	R-5	Rural-5 Acre	Single Family Res-Combo
09 103098 RK	CITY	City	Single Family Res-Combo
07 113993 RK	R-5	Rural-5 Acre	Single Family Res-Combo
09 103770 RK	CITY	City	Duplex
09 104437 MH	RRT-10	Rural Resource Transition-10	Double Wide
09 103152 RK	RRT-10	Rural Resource Transition-10	Single Family Res-Combo
09 101792 RK	R-5	Rural-5 Acre	Single Family Res-Combo
09 106917 RK	R-5	Rural-5 Acre	Single Family Residential
09 103208 RK	R-5	Rural-5 Acre	Single Family Res-Combo
08 109927 RK	R-5	Rural-5 Acre	Single Family Res-Combo
09 103444 RK	CITY	City	Single Family Res-Combo
09 104129 RK	RRT-10	Rural Resource Transition-10	Single Family Residential
07 106563 000 01 RK	R-5	Rural-5 Acre	Single Family Res-Combo
09 106913 RK	R-5	Rural-5 Acre	Single Family Residential
09 101728 RK	R-5	Rural-5 Acre	Single Family Res-Combo
09 101478 RK	R-5	Rural-5 Acre	Single Family Res-Combo
09 107962 RK	R-7,200	Residential 7,200 sq. ft.	Single Family Residential
09 100217 RK	R-7,200	Residential 7,200 sq. ft.	Single Family Res-Combo
09 107322 RK	PRD SA-1	Suburban Agriculture-1 Acre	Single Family Residential
08 106897 RK	R-5	Rural-5 Acre	Single Family Res-Combo
08 108905 RK	R-5	Rural-5 Acre	Single Family Res-Combo
09 104715 RK	R-5	Rural-5 Acre	Single Family Residential
07 108580 000 01 RK	F	Forestry	Single Family Res-Combo
09 101197 RK	R-5	Rural-5 Acre	Single Family Res-Combo
08 110611 RK	R-5	Rural-5 Acre	Single Family Res-Combo
09 102438 RK	F	Forestry	Single Family Res-Combo
09 100843 RK	R-5	Rural-5 Acre	Single Family Res-Combo
07 100685 000 01 RK	R-5	Rural-5 Acre	Single Family Res-Combo
09 101144 RK	R-5	Rural-5 Acre	Single Family Res-Combo
09 104109 RK	R-5	Rural-5 Acre	Single Family Residential

Accessory Dwelling Units

Index # - File Name: 1.0022 - Single Family Dwellings Data\_Snohomish County.pdf

07 100161 000 01 RK	R-5	Rural-5 Acre	Single Family Res-Combo
09 107651 RK	F and R : R-5	Forestry and Recreation : Ru	Single Family Residential
09 107652 RK	F and R : R-5	Forestry and Recreation : Ru	Single Family Residential
08 111118 RK	R-5	Rural-5 Acre	Single Family Res-Combo
09 100177 RK	R-5	Rural-5 Acre	Single Family Res-Combo
09 100655 RK	R-7,200	Residential 7,200 sq. ft.	Duplex-Combo
09 104880 RK	F	Forestry	Single Family Residential
09 102466 RK	R-5	Rural-5 Acre	Single Family Res-Combo
09 106478 MH	R-5	Rural-5 Acre	Single Wide
09 102218 RK	R-5	Rural-5 Acre	Single Family Res-Combo
09 100468 RK	R-12,500	Residential 12,500 sq. ft.	Single Family Res-Combo
09 107239 RK	R-9,600	Residential 9,600 sq. ft.	Duplex-Basic
08 109670 RK	WFB	Waterfront Beach	Single Family Res-Combo
09 103683 RK	F	Forestry	Single Family Residential
06 133928 000 01 RK	R-5	Rural-5 Acre	Single Family Res-Combo
09 104405 RK	R-5	Rural-5 Acre	Accessory Apt Detached
08 106875 RK	R-9,600	Residential 9,600 sq. ft.	Single Family Res-Combo
09 100387 RK	R-8,400	Residential 8,400 sq. ft.	Single Family Res-Combo
07 104673 000 01 RK	R-9,600	Residential 9,600 sq. ft.	Duplex-Combo
09 104075 RK	R-5	Rural-5 Acre	Accessory Apt Detached
08 109737 RK	A-10	Agriculture-10 Acre	Single Family Res-Combo
09 101589 RK	F	Forestry	Single Family Res-Combo
09 106040 RK	R-5	Rural-5 Acre	Single Family Residential
09 106412 RK	R-5	Rural-5 Acre	Single Family Residential
09 104776 RK	R-5	Rural-5 Acre	Single Family Residential
08 104534 RK	R-5	Rural-5 Acre	Single Family Res-Combo
09 100054 RK	R-5	Rural-5 Acre	Single Family Res-Combo
09 104251 RK	R-5	Rural-5 Acre	Single Family Residential
09 104440 RK	F	Forestry	Single Family Residential
09 100961 RK	R-5	Rural-5 Acre	Single Family Res-Combo
08 106682 MH	R-5	Rural-5 Acre	Double Wide
09 105978 MH	R-5	Rural-5 Acre	Triple Wide
09 104353 RK	R-5	Rural-5 Acre	Single Family Res-Combo
09 103597 RK	R-7,200	Residential 7,200 sq. ft.	SFR-Basic
07 105238 000 01 RK	R-7,200	Residential 7,200 sq. ft.	SFR-Basic
06 137064 000 01 RK	R-7,200	Residential 7,200 sq. ft.	SFR-Basic
09 103258 RK	R-7,200	Residential 7,200 sq. ft.	Single Family Res-Combo
06 137137 000 01 RK	R-7,200	Residential 7,200 sq. ft.	SFR-Basic
06 137079 000 01 RK	R-7,200	Residential 7,200 sq. ft.	SFR-Basic
09 101413 RK	R-7,200	Residential 7,200 sq. ft.	SFR-Basic
09 103614 RK	R-7,200	Residential 7,200 sq. ft.	Single Family Residential
09 102033 RK	R-7,200	Residential 7,200 sq. ft.	Single Family Res-Combo
06 137065 000 01 RK	R-7,200	Residential 7,200 sq. ft.	SFR-Basic
09 103145 RK	R-7,200	Residential 7,200 sq. ft.	Single Family Res-Combo
09 103192 RK	R-7,200	Residential 7,200 sq. ft.	SFR-Basic
09 105870 RK	R-7,200	Residential 7,200 sq. ft.	SFR-Basic
09 108716 RK	R-7,200	Residential 7,200 sq. ft.	SFR-Basic

Accessory Dwelling Units

Index # - File Name: 1.0022 - Single Family Dwellings Data\_Snohomish County.pdf

09 108720 RK	R-7,200	Residential 7,200 sq. ft.	SFR-Basic
09 107763 RK	R-7,200	Residential 7,200 sq. ft.	SFR-Basic
09 107764 RK	R-7,200	Residential 7,200 sq. ft.	SFR-Basic
09 107765 RK	R-7,200	Residential 7,200 sq. ft.	SFR-Basic
09 106237 RK	R-7,200	Residential 7,200 sq. ft.	SFR-Basic
09 104923 RK	R-7,200	Residential 7,200 sq. ft.	SFR-Basic
09 106238 RK	R-7,200	Residential 7,200 sq. ft.	SFR-Basic
09 105362 RK	R-7,200	Residential 7,200 sq. ft.	SFR-Basic
09 106235 RK	R-7,200	Residential 7,200 sq. ft.	SFR-Basic
09 106236 RK	R-7,200	Residential 7,200 sq. ft.	SFR-Basic
09 104920 RK	R-7,200	Residential 7,200 sq. ft.	SFR-Basic
09 104921 RK	R-7,200	Residential 7,200 sq. ft.	SFR-Basic
09 104922 RK	R-7,200	Residential 7,200 sq. ft.	SFR-Basic
09 107762 RK	R-7,200	Residential 7,200 sq. ft.	SFR-Basic
09 108717 RK	R-7,200	Residential 7,200 sq. ft.	SFR-Basic
09 108718 RK	R-7,200	Residential 7,200 sq. ft.	SFR-Basic
09 104207 RK	R-7,200	Residential 7,200 sq. ft.	SFR-Basic
09 108719 RK	R-7,200	Residential 7,200 sq. ft.	SFR-Basic
08 100328 000 01 RK	R-7,200	Residential 7,200 sq. ft.	Single Family Res-Combo
08 100330 000 01 RK	R-7,200	Residential 7,200 sq. ft.	Single Family Res-Combo
08 104172 000 01 RK	R-7,200	Residential 7,200 sq. ft.	Single Family Res-Combo
08 105214 RK	R-5	Rural-5 Acre	Single Family Res-Combo
07 107490 000 01 RK	F	Forestry	Single Family Res-Combo
09 101534 RK	R-5	Rural-5 Acre	Accessory Apt Detached-Combo
08 110865 RK	R-5	Rural-5 Acre	Single Family Res-Combo
07 108929 000 01 RK	R-7,200	Residential 7,200 sq. ft.	Single Family Res-Combo
06 129428 000 01 RK	RRT-10	Rural Resource Transition-10	Single Family Res-Combo
09 108715 RK	R-7,200	Residential 7,200 sq. ft.	SFR-Basic
09 108454 RK	R-7,200	Residential 7,200 sq. ft.	SFR-Basic
09 108455 RK	R-7,200	Residential 7,200 sq. ft.	SFR-Basic
09 108456 RK	R-7,200	Residential 7,200 sq. ft.	SFR-Basic
09 107757 RK	R-7,200	Residential 7,200 sq. ft.	SFR-Basic
09 107758 RK	R-7,200	Residential 7,200 sq. ft.	SFR-Basic
09 107759 RK	R-7,200	Residential 7,200 sq. ft.	SFR-Basic
09 107760 RK	R-7,200	Residential 7,200 sq. ft.	SFR-Basic
09 101624 RK	R-7,200	Residential 7,200 sq. ft.	SFR-Basic
09 101625 RK	R-7,200	Residential 7,200 sq. ft.	SFR-Basic
09 101519 RK	R-7,200	Residential 7,200 sq. ft.	SFR-Basic
09 103830 RK	CITY	City	SFR-Basic
09 107526 RK	CITY	City	SFR-Basic
09 104197 RK	R-7,200	Residential 7,200 sq. ft.	SFR-Basic
09 104198 RK	R-7,200	Residential 7,200 sq. ft.	SFR-Basic
09 104199 RK	R-7,200	Residential 7,200 sq. ft.	SFR-Basic
09 104200 RK	R-7,200	Residential 7,200 sq. ft.	SFR-Basic
09 107755 RK	R-7,200	Residential 7,200 sq. ft.	SFR-Basic
09 107756 RK	R-7,200	Residential 7,200 sq. ft.	SFR-Basic
09 103586 RK	R-7,200	Residential 7,200 sq. ft.	SFR-Basic

Accessory Dwelling Units

Index # - File Name: 1.0022 - Single Family Dwellings Data\_Snohomish County.pdf

09 104201 RK	R-7,200	Residential 7,200 sq. ft.	SFR-Basic
09 104202 RK	R-7,200	Residential 7,200 sq. ft.	SFR-Basic
09 104203 RK	R-7,200	Residential 7,200 sq. ft.	SFR-Basic
09 104204 RK	R-7,200	Residential 7,200 sq. ft.	SFR-Basic
09 102967 RK	R-7,200	Residential 7,200 sq. ft.	SFR-Basic
09 102229 RK	R-7,200	Residential 7,200 sq. ft.	SFR-Basic
09 102968 RK	R-7,200	Residential 7,200 sq. ft.	SFR-Basic
09 102969 RK	R-7,200	Residential 7,200 sq. ft.	SFR-Basic
09 102970 RK	R-7,200	Residential 7,200 sq. ft.	SFR-Basic
09 101622 RK	R-7,200	Residential 7,200 sq. ft.	SFR-Basic
09 101623 RK	R-7,200	Residential 7,200 sq. ft.	SFR-Basic
09 108451 RK	R-7,200	Residential 7,200 sq. ft.	SFR-Basic
09 108452 RK	R-7,200	Residential 7,200 sq. ft.	SFR-Basic
09 108453 RK	R-7,200	Residential 7,200 sq. ft.	SFR-Basic
07 108099 000 01 RK	R-5	Rural-5 Acre	Single Family Res-Combo
07 112843 000 01 RK	RD	Rural Diversification	Accessory Apt Detached-Combo
09 107797 RK	MR	Multiple Residential	SFR-Basic
09 107339 RK	R-5	Rural-5 Acre	Single Family Residential
09 104859 MH	R-5	Rural-5 Acre	Double Wide
09 102816 RK	R-5	Rural-5 Acre	Single Family Res-Combo
06 134738 RK	R-5	Rural-5 Acre	Single Family Res-Combo
09 104471 RK	R-7,200	Residential 7,200 sq. ft.	SFR-Basic
09 108877 RK	R-7,200	Residential 7,200 sq. ft.	SFR-Basic
08 111111 RK	R-7,200	Residential 7,200 sq. ft.	SFR-Basic
09 101879 RK	R-7,200	Residential 7,200 sq. ft.	SFR-Basic
09 104678 RK	R-7,200	Residential 7,200 sq. ft.	SFR-Basic
09 104295 RK	R-7,200	Residential 7,200 sq. ft.	SFR-Basic
09 105567 RK	MR	Multiple Residential	SFR-Basic
09 105568 RK	MR	Multiple Residential	SFR-Basic
09 105569 RK	MR	Multiple Residential	SFR-Basic
09 105570 RK	MR	Multiple Residential	SFR-Basic
09 108618 RK	LDMR	Low Density Multiple Reside	SFR-Basic
09 107739 RK	LDMR	Low Density Multiple Reside	SFR-Basic
09 107740 RK	LDMR	Low Density Multiple Reside	SFR-Basic
09 107741 RK	LDMR	Low Density Multiple Reside	SFR-Basic
09 105741 RK	LDMR	Low Density Multiple Reside	SFR-Basic
09 105431 RK	LDMR	Low Density Multiple Reside	SFR-Basic
09 107737 RK	LDMR	Low Density Multiple Reside	SFR-Basic
09 107738 RK	LDMR	Low Density Multiple Reside	SFR-Basic
09 108616 RK	LDMR	Low Density Multiple Reside	SFR-Basic
09 108617 RK	LDMR	Low Density Multiple Reside	SFR-Basic
09 105571 RK	MR	Multiple Residential	Duplex-Basic
09 105572 RK	MR	Multiple Residential	Duplex-Basic
09 105432 RK	LDMR	Low Density Multiple Reside	SFR-Basic
09 105434 RK	LDMR	Low Density Multiple Reside	SFR-Basic
09 105435 RK	LDMR	Low Density Multiple Reside	SFR-Basic
09 105436 RK	LDMR	Low Density Multiple Reside	SFR-Basic

Accessory Dwelling Units

Index # - File Name: 1.0022 - Single Family Dwellings Data\_Snohomish County.pdf

09 105437 RK	LDMR	Low Density Multiple Reside	SFR-Basic
09 105438 RK	LDMR	Low Density Multiple Reside	SFR-Basic
09 105439 RK	LDMR	Low Density Multiple Reside	SFR-Basic
09 105440 RK	LDMR	Low Density Multiple Reside	SFR-Basic
09 105441 RK	LDMR	Low Density Multiple Reside	SFR-Basic
09 105742 RK	LDMR	Low Density Multiple Reside	SFR-Basic
09 105743 RK	LDMR	Low Density Multiple Reside	SFR-Basic
09 107742 RK	LDMR	Low Density Multiple Reside	SFR-Basic
09 107185 RK	LDMR	Low Density Multiple Reside	SFR-Basic
09 107743 RK	LDMR	Low Density Multiple Reside	SFR-Basic
09 107186 RK	LDMR	Low Density Multiple Reside	SFR-Basic
09 105744 RK	LDMR	Low Density Multiple Reside	SFR-Basic
09 105745 RK	LDMR	Low Density Multiple Reside	SFR-Basic
09 105746 RK	LDMR	Low Density Multiple Reside	SFR-Basic
09 105443 RK	LDMR	Low Density Multiple Reside	SFR-Basic
09 105566 RK	MR	Multiple Residential	SFR-Basic
09 105429 RK	LDMR	Low Density Multiple Reside	SFR-Basic
09 105430 RK	LDMR	Low Density Multiple Reside	SFR-Basic
09 105433 RK	LDMR	Low Density Multiple Reside	SFR-Basic
09 105442 RK	LDMR	Low Density Multiple Reside	SFR-Basic
09 105444 RK	LDMR	Low Density Multiple Reside	SFR-Basic
09 105445 RK	LDMR	Low Density Multiple Reside	SFR-Basic
09 105446 RK	LDMR	Low Density Multiple Reside	SFR-Basic
09 105447 RK	LDMR	Low Density Multiple Reside	SFR-Basic
09 105448 RK	LDMR	Low Density Multiple Reside	SFR-Basic
09 105740 RK	LDMR	Low Density Multiple Reside	SFR-Basic
08 108459 RK	R-7,200(PRD)	Residential 7,200 sq. ft.	SFR-Basic
09 103678 RK	R-5	Rural-5 Acre	Single Family Residential
09 106688 RK	R-5	Rural-5 Acre	Single Family Residential
09 103922 RK	R-9,600	Residential 9,600 sq. ft.	SFR-Basic
09 104470 RK	R-7,200	Residential 7,200 sq. ft.	SFR-Basic
09 104677 RK	R-7,200	Residential 7,200 sq. ft.	SFR-Basic
09 102526 RK	R-7,200	Residential 7,200 sq. ft.	SFR-Basic
09 102031 RK	R-7,200	Residential 7,200 sq. ft.	SFR-Basic
09 103474 RK	R-7,200	Residential 7,200 sq. ft.	SFR-Basic
09 101523 RK	R-7,200	Residential 7,200 sq. ft.	SFR-Basic
09 102652 RK	R-7,200	Residential 7,200 sq. ft.	SFR-Basic
09 106288 RK	R-7,200	Residential 7,200 sq. ft.	SFR-Basic
09 105992 RK	R-7,200	Residential 7,200 sq. ft.	SFR-Basic
09 106616 RK	R-7,200	Residential 7,200 sq. ft.	SFR-Basic
09 107128 RK	R-7,200	Residential 7,200 sq. ft.	SFR-Basic
09 105993 RK	R-7,200	Residential 7,200 sq. ft.	SFR-Basic
09 104517 RK	CITY	City	SFR-Basic
09 103821 RK	CITY	City	SFR-Basic
09 103825 RK	CITY	City	SFR-Basic
09 105210 RK	CITY	City	Single Family Residential
09 104526 RK	CITY	City	SFR-Basic



Accessory Dwelling Units

Index # - File Name: 1.0022 - Single Family Dwellings Data\_Snohomish County.pdf

09 103829 RK	CITY	City	SFR-Basic
09 104527 RK	CITY	City	SFR-Basic
09 105084 RK	CITY	City	SFR-Basic
09 105085 RK	CITY	City	SFR-Basic
09 105081 RK	CITY	City	SFR-Basic
09 105082 RK	CITY	City	SFR-Basic
09 105083 RK	CITY	City	SFR-Basic
09 105086 RK	CITY	City	SFR-Basic
09 104518 RK	CITY	City	SFR-Basic
09 105328 RK	CITY	City	SFR-Basic
09 105419 RK	CITY	City	Single Family Residential
09 105329 RK	CITY	City	SFR-Basic
09 104520 RK	CITY	City	SFR-Basic
09 105330 RK	CITY	City	SFR-Basic
09 105331 RK	CITY	City	SFR-Basic
09 103822 RK	CITY	City	SFR-Basic
09 103823 RK	CITY	City	SFR-Basic
09 103824 RK	CITY	City	SFR-Basic
09 104521 RK	CITY	City	SFR-Basic
09 105332 RK	CITY	City	SFR-Basic
09 104522 RK	CITY	City	SFR-Basic
09 104523 RK	CITY	City	SFR-Basic
09 104524 RK	CITY	City	SFR-Basic
09 104525 RK	CITY	City	SFR-Basic
09 103826 RK	CITY	City	SFR-Basic
09 103827 RK	CITY	City	SFR-Basic
09 103828 RK	CITY	City	SFR-Basic
09 105333 RK	CITY	City	SFR-Basic
09 104911 RK	R-7,200	Residential 7,200 sq. ft.	SFR-Basic
09 104910 RK	R-7,200	Residential 7,200 sq. ft.	SFR-Basic
09 103811 RK	R-7,200	Residential 7,200 sq. ft.	SFR-Basic
09 106617 RK	R-7,200	Residential 7,200 sq. ft.	SFR-Basic
09 104472 RK	R-7,200	Residential 7,200 sq. ft.	SFR-Basic
09 103141 RK	R-7,200(PRD)	Residential 7,200 sq. ft.	SFR-Basic
09 103142 RK	R-7,200(PRD)	Residential 7,200 sq. ft.	SFR-Basic
09 103143 RK	R-7,200(PRD)	Residential 7,200 sq. ft.	SFR-Basic
09 103144 RK	R-7,200(PRD)	Residential 7,200 sq. ft.	SFR-Basic
09 101498 RK	R-9,600	Residential 9,600 sq. ft.	Single Family Res-Combo
09 100928 RK	R-5	Rural-5 Acre	Single Family Res-Combo
09 103086 RK	CITY	City	SFR-Basic
09 100189 RK	CITY	City	SFR-Basic
09 100190 RK	CITY	City	SFR-Basic
09 103087 RK	CITY	City	SFR-Basic
09 103585 RK	CITY	City	SFR-Basic
09 104564 RK	CITY	City	SFR-Basic
09 100761 RK	CITY	City	SFR-Basic
09 100191 RK	CITY	City	SFR-Basic

Accessory Dwelling Units

Index # - File Name: 1.0022 - Single Family Dwellings Data\_Snohomish County.pdf

09 100762 RK	CITY	City	SFR-Basic
09 100763 RK	CITY	City	SFR-Basic
09 101514 RK	CITY	City	SFR-Basic
09 101852 RK	CITY	City	SFR-Basic
09 101853 RK	CITY	City	SFR-Basic
09 101854 RK	CITY	City	SFR-Basic
09 101146 RK	CITY	City	SFR-Basic
09 103089 RK	CITY	City	SFR-Basic
09 103090 RK	CITY	City	SFR-Basic
09 103091 RK	CITY	City	SFR-Basic
09 103331 RK	R-9,600	Residential 9,600 sq. ft.	SFR-Basic
09 103332 RK	R-9,600	Residential 9,600 sq. ft.	SFR-Basic
09 103333 RK	R-9,600	Residential 9,600 sq. ft.	SFR-Basic
09 103328 RK	R-9,600	Residential 9,600 sq. ft.	Single Family Res-Combo
09 103088 RK	CITY	City	SFR-Basic
09 103329 RK	R-9,600	Residential 9,600 sq. ft.	SFR-Basic
09 103325 RK	R-9,600	Residential 9,600 sq. ft.	Single Family Res-Combo
09 103330 RK	R-9,600	Residential 9,600 sq. ft.	SFR-Basic
09 101982 RK	R-7,200	Residential 7,200 sq. ft.	SFR-Basic
09 105062 RK	R-7,200	Residential 7,200 sq. ft.	SFR-Basic
09 108209 RK	R-7,200	Residential 7,200 sq. ft.	SFR-Basic
09 108210 RK	R-7,200	Residential 7,200 sq. ft.	SFR-Basic
09 108211 RK	R-7,200	Residential 7,200 sq. ft.	SFR-Basic
09 101980 RK	R-7,200	Residential 7,200 sq. ft.	SFR-Basic
09 101981 RK	R-7,200	Residential 7,200 sq. ft.	SFR-Basic
09 105918 RK	R-9,600	Residential 9,600 sq. ft.	Single Family Residential
09 104819 RK	R-5	Rural-5 Acre	Single Family Residential
08 110065 RK	R-5	Rural-5 Acre	Single Family Res-Combo
09 105063 RK	R-7,200	Residential 7,200 sq. ft.	SFR-Basic
09 101983 RK	R-7,200	Residential 7,200 sq. ft.	SFR-Basic
09 101984 RK	R-7,200	Residential 7,200 sq. ft.	SFR-Basic
09 106682 RK	R-5	Rural-5 Acre	Single Family Residential
07 107477 RK	R-7,200(PRD)	Residential 7,200 sq. ft.	SFR-Basic
09 104162 RK	R-7,200(PRD)	Residential 7,200 sq. ft.	SFR-Basic
09 103981 RK	R-7,200(PRD)	Residential 7,200 sq. ft.	SFR-Basic
09 104163 RK	R-7,200(PRD)	Residential 7,200 sq. ft.	SFR-Basic
09 103982 RK	R-7,200(PRD)	Residential 7,200 sq. ft.	SFR-Basic
09 103983 RK	R-7,200(PRD)	Residential 7,200 sq. ft.	SFR-Basic
09 100536 RK	R-7,200	Residential 7,200 sq. ft.	SFR-Basic
07 107189 000 01 RK	R-7,200	Residential 7,200 sq. ft.	SFR-Basic
09 108587 RK	R-7,200	Residential 7,200 sq. ft.	SFR-Basic
09 108588 RK	R-7,200	Residential 7,200 sq. ft.	SFR-Basic
09 101147 RK	R-7,200	Residential 7,200 sq. ft.	SFR-Basic
09 106384 RK	R-7,200	Residential 7,200 sq. ft.	SFR-Basic
09 106383 RK	R-7,200	Residential 7,200 sq. ft.	SFR-Basic
07 107723 RK	R-7,200	Residential 7,200 sq. ft.	SFR-Basic
09 103138 RK	R-7,200	Residential 7,200 sq. ft.	SFR-Basic

Accessory Dwelling Units

Index # - File Name: 1.0022 - Single Family Dwellings Data\_Snohomish County.pdf

09 103137 RK	R-7,200	Residential 7,200 sq. ft.	SFR-Basic
09 103139 RK	R-7,200	Residential 7,200 sq. ft.	SFR-Basic
09 101013 RK	R-7,200	Residential 7,200 sq. ft.	SFR-Basic
07 107728 RK	R-7,200	Residential 7,200 sq. ft.	SFR-Basic
09 100318 RK	R-5	Rural-5 Acre	Single Family Res-Combo
09 108584 RK	R-7,200	Residential 7,200 sq. ft.	SFR-Basic
09 108586 RK	R-7,200	Residential 7,200 sq. ft.	SFR-Basic
09 109089 RK	MR	Multiple Residential	SFR-Basic
09 109083 RK	MR	Multiple Residential	SFR-Basic
09 109084 RK	MR	Multiple Residential	SFR-Basic
09 109085 RK	MR	Multiple Residential	SFR-Basic
09 109086 RK	MR	Multiple Residential	SFR-Basic
09 109087 RK	MR	Multiple Residential	SFR-Basic
09 109088 RK	MR	Multiple Residential	SFR-Basic
09 101880 RK	CITY	City	SFR-Basic
09 103445 RK	CITY	City	SFR-Basic
09 103446 RK	CITY	City	SFR-Basic
09 103440 RK	CITY	City	SFR-Basic
09 108159 RK	CITY	City	SFR-Basic
09 102063 RK	CITY	City	SFR-Basic
09 102064 RK	CITY	City	SFR-Basic
09 102061 RK	CITY	City	SFR-Basic
09 102908 RK	CITY	City	SFR-Basic
09 108158 RK	CITY	City	SFR-Basic
09 106924 RK	CITY	City	SFR-Basic
09 100269 RK	CITY	City	SFR-Basic
09 102901 RK	CITY	City	SFR-Basic
09 102902 RK	CITY	City	SFR-Basic
09 105613 RK	CITY	City	SFR-Basic
09 102906 RK	CITY	City	SFR-Basic
09 102062 RK	CITY	City	SFR-Basic
09 100949 RK	CITY	City	SFR-Basic
09 100953 RK	CITY	City	SFR-Basic
09 100950 RK	CITY	City	SFR-Basic
09 101689 RK	CITY	City	SFR-Basic
09 101075 RK	CITY	City	SFR-Basic
09 102467 RK	CITY	City	SFR-Basic
09 101028 RK	CITY	City	SFR-Basic
09 100951 RK	CITY	City	SFR-Basic
08 111449 RK	CITY	City	SFR-Basic
08 111434 RK	CITY	City	SFR-Basic
09 100043 RK	CITY	City	SFR-Basic
08 111450 RK	CITY	City	SFR-Basic
08 111435 RK	CITY	City	SFR-Basic
09 100041 RK	CITY	City	SFR-Basic
09 105363 RK	CITY	City	SFR-Basic
09 105364 RK	CITY	City	SFR-Basic

Accessory Dwelling Units

Index # - File Name: 1.0022 - Single Family Dwellings Data\_Snohomish County.pdf

09 105365 RK	CITY	City	SFR-Basic
09 105366 RK	CITY	City	SFR-Basic
09 105367 RK	CITY	City	SFR-Basic
09 107750 RK	CITY	City	SFR-Basic
09 106844 RK	CITY	City	SFR-Basic
09 107751 RK	CITY	City	SFR-Basic
09 107752 RK	CITY	City	SFR-Basic
09 107753 RK	CITY	City	SFR-Basic
09 107754 RK	CITY	City	SFR-Basic
09 108437 RK	CITY	City	SFR-Basic
09 108438 RK	CITY	City	SFR-Basic
09 108439 RK	CITY	City	SFR-Basic
09 108441 RK	CITY	City	SFR-Basic
09 108442 RK	CITY	City	SFR-Basic
09 106845 RK	CITY	City	SFR-Basic
09 106846 RK	CITY	City	SFR-Basic
09 106847 RK	CITY	City	SFR-Basic
09 108440 RK	CITY	City	SFR-Basic
09 105667 RK	CITY	City	SFR-Basic
09 105368 RK	CITY	City	SFR-Basic
09 106874 RK	R-5	Rural-5 Acre	Single Family Residential
09 107801 RK	R-7,200(PRD)	Residential 7,200 sq. ft.	SFR-Basic
09 100498 RK	R-7,200(PRD)	Residential 7,200 sq. ft.	SFR-Basic
09 106605 RK	R-7,200(PRD)	Residential 7,200 sq. ft.	SFR-Basic
09 100497 RK	R-7,200(PRD)	Residential 7,200 sq. ft.	SFR-Basic
09 106860 RK	R-7,200(PRD)	Residential 7,200 sq. ft.	SFR-Basic
09 108301 RK	R-7,200(PRD)	Residential 7,200 sq. ft.	SFR-Basic
09 108302 RK	R-7,200(PRD)	Residential 7,200 sq. ft.	SFR-Basic
09 108873 RK	R-7,200(PRD)	Residential 7,200 sq. ft.	SFR-Basic
09 107744 RK	R-5	Rural-5 Acre	Single Family Residential
09 108200 RK	R-7,200	Residential 7,200 sq. ft.	SFR-Basic
09 108203 RK	R-7,200	Residential 7,200 sq. ft.	SFR-Basic
07 107697 000 01 RK	R-7,200(PRD)	Residential 7,200 sq. ft.	SFR-Basic
07 107695 000 01 RK	R-7,200(PRD)	Residential 7,200 sq. ft.	SFR-Basic
09 104909 RK	R-7,200	Residential 7,200 sq. ft.	SFR-Basic
09 103595 RK	R-7,200	Residential 7,200 sq. ft.	SFR-Basic
09 102525 RK	R-7,200	Residential 7,200 sq. ft.	SFR-Basic
09 100140 RK	R-7,200	Residential 7,200 sq. ft.	SFR-Basic
09 100141 RK	R-7,200	Residential 7,200 sq. ft.	SFR-Basic
09 107127 RK	R-7,200	Residential 7,200 sq. ft.	SFR-Basic
09 103810 RK	R-7,200	Residential 7,200 sq. ft.	SFR-Basic
08 109829 RK	R-5	Rural-5 Acre	Single Family Res-Combo
09 105322 RK	R-9,600	Residential 9,600 sq. ft.	SFR-Basic
09 105320 RK	R-9,600	Residential 9,600 sq. ft.	SFR-Basic
07 104869 000 01 RK	R-7,200(PRD)	Residential 7,200 sq. ft.	SFR-Basic
07 105294 000 01 RK	R-7,200(PRD)	Residential 7,200 sq. ft.	SFR-Basic
07 104953 000 01 RK	PRD-9,600	Residential 9,600 sq. ft.	SFR-Basic

Accessory Dwelling Units

Index # - File Name: 1.0022 - Single Family Dwellings Data\_Snohomish County.pdf

07 104960 000 01 RK	PRD-9,600	Residential 9,600 sq. ft.	SFR-Basic
07 103846 000 01 RK	PRD-9,600	Residential 9,600 sq. ft.	SFR-Basic
07 103847 000 01 RK	PRD-9,600	Residential 9,600 sq. ft.	SFR-Basic
07 103848 000 01 RK	PRD-9,600	Residential 9,600 sq. ft.	SFR-Basic
07 103849 000 01 RK	PRD-9,600	Residential 9,600 sq. ft.	SFR-Basic
07 104962 000 01 RK	PRD-9,600	Residential 9,600 sq. ft.	SFR-Basic
07 104963 000 01 RK	PRD-9,600	Residential 9,600 sq. ft.	SFR-Basic
07 104965 000 01 RK	PRD-9,600	Residential 9,600 sq. ft.	SFR-Basic
07 105082 000 01 RK	PRD-9,600	Residential 9,600 sq. ft.	SFR-Basic
07 103854 000 01 RK	PRD-9,600	Residential 9,600 sq. ft.	SFR-Basic
09 104008 RK	CITY	City	SFR-Basic
09 104671 RK	CITY	City	SFR-Basic
09 107527 RK	CITY	City	SFR-Basic
09 105410 RK	CITY	City	SFR-Basic
09 107528 RK	CITY	City	SFR-Basic
09 104474 RK	CITY	City	SFR-Basic
07 106528 000 01 RK	PRD-9,600	Residential 9,600 sq. ft.	SFR-Basic
07 101395 000 01 RK	PRD-9,600	Residential 9,600 sq. ft.	SFR-Basic
07 106521 000 01 RK	PRD-9,600	Residential 9,600 sq. ft.	SFR-Basic
07 106522 000 01 RK	PRD-9,600	Residential 9,600 sq. ft.	SFR-Basic
07 106515 000 01 RK	PRD-9,600	Residential 9,600 sq. ft.	SFR-Basic
07 106516 000 01 RK	PRD-9,600	Residential 9,600 sq. ft.	SFR-Basic
07 106517 000 01 RK	PRD-9,600	Residential 9,600 sq. ft.	SFR-Basic
07 106518 000 01 RK	PRD-9,600	Residential 9,600 sq. ft.	SFR-Basic
09 105994 RK	CITY	City	SFR-Basic
09 104473 RK	CITY	City	SFR-Basic
09 104670 RK	CITY	City	SFR-Basic
09 105409 RK	CITY	City	SFR-Basic
09 103285 RK	R-5	Rural-5 Acre	Single Family Res-Combo
08 110664 RK	R-5	Rural-5 Acre	Single Family Res-Combo
09 101601 RK	R-5	Rural-5 Acre	Single Family Res-Combo
09 108208 RK	R-5	Rural-5 Acre	Single Family Residential
09 103193 RK	R-7,200	Residential 7,200 sq. ft.	SFR-Basic
09 103194 RK	R-7,200	Residential 7,200 sq. ft.	SFR-Basic
09 103428 RK	R-7,200	Residential 7,200 sq. ft.	SFR-Basic
08 111030 RK	R-7,200	Residential 7,200 sq. ft.	Single Family Res-Combo
09 100291 RK	R-7,200	Residential 7,200 sq. ft.	Single Family Res-Combo
09 108119 RK	R-7,200	Residential 7,200 sq. ft.	SFR-Basic
09 108117 RK	R-7,200	Residential 7,200 sq. ft.	SFR-Basic
09 105674 RK	R-7,200	Residential 7,200 sq. ft.	SFR-Basic
09 106755 RK	R-7,200	Residential 7,200 sq. ft.	SFR-Basic
09 101012 RK	CITY	City	Single Family Res-Combo
09 106370 RK	R-7,200	Residential 7,200 sq. ft.	SFR-Basic
09 106694 RK	LDMR	Low Density Multiple Reside	SFR-Basic
08 110614 RK	R-5	Rural-5 Acre	Single Family Res-Combo
09 101750 RK	R-5	Rural-5 Acre	Single Family Res-Combo
07 115032 000 01 RK	R-9,600	Residential 9,600 sq. ft.	Single Family Res-Combo

Accessory Dwelling Units

Index # - File Name: 1.0022 - Single Family Dwellings Data\_Snohomish County.pdf

09 107222 RK	R-5	Rural-5 Acre	Single Family Residential
09 101140 RK	R-9,600	Residential 9,600 sq. ft.	SFR-Basic
09 101141 RK	R-9,600	Residential 9,600 sq. ft.	SFR-Basic
09 101142 RK	R-9,600	Residential 9,600 sq. ft.	SFR-Basic
09 101143 RK	R-9,600	Residential 9,600 sq. ft.	SFR-Basic
09 106850 RK	R-9,600	Residential 9,600 sq. ft.	SFR-Basic
09 107391 RK	R-9,600	Residential 9,600 sq. ft.	SFR-Basic
09 107392 RK	R-9,600	Residential 9,600 sq. ft.	SFR-Basic
09 108467 RK	R-9,600	Residential 9,600 sq. ft.	SFR-Basic
09 108468 RK	R-9,600	Residential 9,600 sq. ft.	SFR-Basic
09 108469 RK	R-9,600	Residential 9,600 sq. ft.	SFR-Basic
09 107761 RK	R-9,600	Residential 9,600 sq. ft.	SFR-Basic
09 107393 RK	R-9,600	Residential 9,600 sq. ft.	SFR-Basic
09 107394 RK	R-9,600	Residential 9,600 sq. ft.	SFR-Basic
09 107395 RK	R-9,600	Residential 9,600 sq. ft.	SFR-Basic
09 103017 RK	R-9,600	Residential 9,600 sq. ft.	SFR-Basic
09 103018 RK	R-9,600	Residential 9,600 sq. ft.	SFR-Basic
09 103019 RK	R-9,600	Residential 9,600 sq. ft.	SFR-Basic
09 103020 RK	R-9,600	Residential 9,600 sq. ft.	SFR-Basic
09 101882 RK	R-9,600	Residential 9,600 sq. ft.	SFR-Basic
09 101883 RK	R-9,600	Residential 9,600 sq. ft.	SFR-Basic
09 107396 RK	R-9,600	Residential 9,600 sq. ft.	SFR-Basic
09 100192 RK	R-9,600	Residential 9,600 sq. ft.	SFR-Basic
09 100193 RK	R-9,600	Residential 9,600 sq. ft.	SFR-Basic
09 101857 RK	R-9,600	Residential 9,600 sq. ft.	SFR-Basic
09 101858 RK	R-9,600	Residential 9,600 sq. ft.	SFR-Basic
09 107389 RK	R-9,600	Residential 9,600 sq. ft.	SFR-Basic
09 107390 RK	R-9,600	Residential 9,600 sq. ft.	SFR-Basic
09 105996 RK	R-9,600	Residential 9,600 sq. ft.	SFR-Basic
09 105997 RK	R-9,600	Residential 9,600 sq. ft.	SFR-Basic
09 105998 RK	R-9,600	Residential 9,600 sq. ft.	SFR-Basic
09 105999 RK	R-9,600	Residential 9,600 sq. ft.	SFR-Basic
08 108375 RK	R-5	Rural-5 Acre	Single Family Res-Combo
09 109213 RK	R-9,600	Residential 9,600 sq. ft.	SFR-Basic
09 109216 RK	R-9,600	Residential 9,600 sq. ft.	SFR-Basic
09 108470 RK	R-9,600	Residential 9,600 sq. ft.	SFR-Basic
09 108471 RK	R-9,600	Residential 9,600 sq. ft.	SFR-Basic
09 109214 RK	R-9,600	Residential 9,600 sq. ft.	SFR-Basic
09 109215 RK	R-9,600	Residential 9,600 sq. ft.	SFR-Basic
09 109211 RK	R-9,600	Residential 9,600 sq. ft.	SFR-Basic
09 109212 RK	R-9,600	Residential 9,600 sq. ft.	SFR-Basic
09 100921 RK	CITY	City	SFR-Basic
09 102404 RK	CITY	City	SFR-Basic
09 102420 RK	CITY	City	SFR-Basic
09 102618 RK	CITY	City	SFR-Basic
09 103025 RK	CITY	City	SFR-Basic
09 103026 RK	CITY	City	SFR-Basic

Accessory Dwelling Units

Index # - File Name: 1.0022 - Single Family Dwellings Data\_Snohomish County.pdf

09 103865 RK	CITY	City	SFR-Basic
09 103867 RK	CITY	City	SFR-Basic
09 103027 RK	CITY	City	SFR-Basic
09 103868 RK	CITY	City	SFR-Basic
09 103869 RK	CITY	City	SFR-Basic
09 103870 RK	CITY	City	SFR-Basic
09 103028 RK	CITY	City	SFR-Basic
09 103029 RK	CITY	City	SFR-Basic
09 102619 RK	CITY	City	SFR-Basic
09 102417 RK	CITY	City	SFR-Basic
09 100922 RK	CITY	City	SFR-Basic
07 110572 000 01 RK	MR	Multiple Residential	Single Family Res-Combo
09 100208 RK	CITY	City	SFR-Basic
09 102402 RK	CITY	City	SFR-Basic
09 100130 RK	CITY	City	SFR-Basic
09 103030 RK	CITY	City	SFR-Basic
09 103031 RK	CITY	City	SFR-Basic
09 102832 RK	CITY	City	SFR-Basic
09 102831 RK	CITY	City	SFR-Basic
09 100207 RK	CITY	City	SFR-Basic
09 106580 RK	R-7,200	Residential 7,200 sq. ft.	Single Family Residential
09 101499 RK	R-5	Rural-5 Acre	Single Family Res-Combo
07 110508 000 01 MH	R-5	Rural-5 Acre	Triple Wide
09 103549 RK	R-7,200	Residential 7,200 sq. ft.	SFR-Basic
09 107002 RK	R-7,200	Residential 7,200 sq. ft.	SFR-Basic
09 106999 RK	R-7,200	Residential 7,200 sq. ft.	SFR-Basic
09 107004 RK	R-7,200	Residential 7,200 sq. ft.	SFR-Basic
09 105974 RK	MR	Multiple Residential	SFR-Basic
09 105970 RK	MR	Multiple Residential	SFR-Basic
09 105973 RK	MR	Multiple Residential	SFR-Basic
09 105971 RK	MR	Multiple Residential	SFR-Basic
09 105972 RK	MR	Multiple Residential	SFR-Basic
09 105975 RK	MR	Multiple Residential	SFR-Basic
08 102861 RK	CITY	City	SFR-Basic
09 100499 RK	R-7,200(PRD)	Residential 7,200 sq. ft.	SFR-Basic
09 108874 RK	R-7,200(PRD)	Residential 7,200 sq. ft.	SFR-Basic
07 111628 RK	R-5	Rural-5 Acre	Single Family Res-Combo
09 100502 RK	R-7,200(PRD)	Residential 7,200 sq. ft.	SFR-Basic
09 107237 RK	R-5	Rural-5 Acre	Single Family Residential
08 102812 000 01 RK	CITY	City	SFR-Basic
08 103560 000 02 RK	CITY	City	SFR-Basic
09 104561 RK	R-9,600	Residential 9,600 sq. ft.	SFR-Basic
09 104562 RK	R-9,600	Residential 9,600 sq. ft.	SFR-Basic
09 106239 RK	R-9,600	Residential 9,600 sq. ft.	SFR-Basic
09 103643 RK	R-5	Rural-5 Acre	SFR-Basic
09 103644 RK	R-5	Rural-5 Acre	SFR-Basic
09 104141 RK	R-5	Rural-5 Acre	Single Family Residential

Accessory Dwelling Units

Index # - File Name: 1.0022 - Single Family Dwellings Data\_Snohomish County.pdf

09 106282 RK	CITY	City	SFR-Basic
09 102937 RK	CITY	City	Single Family Res-Combo
09 106283 RK	CITY	City	SFR-Basic
09 106284 RK	CITY	City	SFR-Basic
09 106545 RK	CITY	City	SFR-Basic
09 105192 RK	R-7,200	Residential 7,200 sq. ft.	Single Family Residential
09 101379 RK	R-7,200(PRD)	Residential 7,200 sq. ft.	SFR-Basic
09 105236 RK	WFB	Waterfront Beach	Single Family Residential
08 105230 RK	WFB	Waterfront Beach	Single Family Res-Combo
09 100608 RK	R-7,200(PRD)	Residential 7,200 sq. ft.	SFR-Basic
09 100496 RK	R-7,200(PRD)	Residential 7,200 sq. ft.	SFR-Basic
09 100413 RK	R-7,200(PRD)	Residential 7,200 sq. ft.	SFR-Basic
09 106843 RK	R-9,600	Residential 9,600 sq. ft.	SFR-Basic
09 106841 RK	R-9,600	Residential 9,600 sq. ft.	SFR-Basic
09 104924 RK	R-9,600	Residential 9,600 sq. ft.	SFR-Basic
09 106842 RK	R-9,600	Residential 9,600 sq. ft.	SFR-Basic
09 109097 RK	R-9,600	Residential 9,600 sq. ft.	SFR-Basic
09 109098 RK	R-9,600	Residential 9,600 sq. ft.	SFR-Basic
09 109099 RK	R-9,600	Residential 9,600 sq. ft.	SFR-Basic
09 109100 RK	R-9,600	Residential 9,600 sq. ft.	SFR-Basic
09 107019 RK	R-9,600	Residential 9,600 sq. ft.	SFR-Basic
09 101855 RK	R-9,600	Residential 9,600 sq. ft.	SFR-Basic
09 101856 RK	R-9,600	Residential 9,600 sq. ft.	SFR-Basic
09 106215 RK	F	Forestry	Single Family Residential
09 102443 RK	CITY	City	SFR-Basic
09 102444 RK	CITY	City	SFR-Basic
09 106323 RK	CITY	City	SFR-Basic
09 106324 RK	CITY	City	SFR-Basic
08 111180 RK	CITY	City	SFR-Basic
07 107940 RK	CITY	City	SFR-Basic
08 111181 RK	CITY	City	SFR-Basic
09 104031 RK	CITY	City	SFR-Basic
08 111182 RK	CITY	City	SFR-Basic
07 107944 RK	CITY	City	SFR-Basic
09 104033 RK	CITY	City	SFR-Basic
07 107947 RK	CITY	City	SFR-Basic
09 104032 RK	CITY	City	SFR-Basic
08 110235 RK	CITY	City	SFR-Basic
08 110236 RK	CITY	City	SFR-Basic
09 103453 RK	CITY	City	SFR-Basic
09 101192 RK	CITY	City	SFR-Basic
09 102440 RK	CITY	City	SFR-Basic
09 106322 RK	CITY	City	SFR-Basic
09 108183 RK	CITY	City	SFR-Basic
09 108564 RK	CITY	City	SFR-Basic
09 108565 RK	CITY	City	SFR-Basic
09 108182 RK	CITY	City	SFR-Basic



Accessory Dwelling Units

Index # - File Name: 1.0022 - Single Family Dwellings Data\_Snohomish County.pdf

09 103451 RK	CITY	City	SFR-Basic
09 102441 RK	CITY	City	SFR-Basic
09 102442 RK	CITY	City	SFR-Basic
09 103452 RK	CITY	City	SFR-Basic
08 100915 000 01 RK	R-7,200	Residential 7,200 sq. ft.	SFR-Basic
08 100916 000 01 RK	R-7,200	Residential 7,200 sq. ft.	SFR-Basic
08 100906 000 01 RK	R-7,200	Residential 7,200 sq. ft.	SFR-Basic
08 100907 000 01 RK	R-7,200	Residential 7,200 sq. ft.	SFR-Basic
08 100908 000 01 RK	R-7,200	Residential 7,200 sq. ft.	SFR-Basic
08 100909 000 01 RK	R-7,200	Residential 7,200 sq. ft.	SFR-Basic
08 100910 000 01 RK	R-7,200	Residential 7,200 sq. ft.	SFR-Basic
08 102668 000 01 RK	R-7,200	Residential 7,200 sq. ft.	SFR-Basic
08 102669 000 01 RK	R-7,200	Residential 7,200 sq. ft.	SFR-Basic
08 100913 000 01 RK	R-7,200	Residential 7,200 sq. ft.	SFR-Basic
08 100914 000 01 RK	R-7,200	Residential 7,200 sq. ft.	SFR-Basic
08 100904 000 01 RK	R-7,200	Residential 7,200 sq. ft.	SFR-Basic
08 102670 000 01 RK	R-7,200	Residential 7,200 sq. ft.	SFR-Basic
08 102671 000 01 RK	R-7,200	Residential 7,200 sq. ft.	SFR-Basic
08 102665 000 01 RK	R-7,200	Residential 7,200 sq. ft.	SFR-Basic
08 102666 000 01 RK	R-7,200	Residential 7,200 sq. ft.	SFR-Basic
09 106970 RK	R-5	Rural-5 Acre	Single Family Residential
09 103543 RK	R-5	Rural-5 Acre	SFR-Basic
09 100751 RK	R-5	Rural-5 Acre	SFR-Basic
09 100750 RK	R-5	Rural-5 Acre	SFR-Basic
09 103437 RK	LDMR	Low Density Multiple Reside	SFR-Basic
09 103438 RK	LDMR	Low Density Multiple Reside	SFR-Basic
09 103439 RK	LDMR	Low Density Multiple Reside	SFR-Basic
09 106527 RK	LDMR	Low Density Multiple Reside	SFR-Basic
09 106528 RK	LDMR	Low Density Multiple Reside	SFR-Basic
09 106529 RK	LDMR	Low Density Multiple Reside	SFR-Basic
09 106530 RK	LDMR	Low Density Multiple Reside	SFR-Basic
09 106531 RK	LDMR	Low Density Multiple Reside	SFR-Basic
09 106532 RK	LDMR	Low Density Multiple Reside	SFR-Basic
09 106533 RK	LDMR	Low Density Multiple Reside	SFR-Basic
09 106534 RK	LDMR	Low Density Multiple Reside	SFR-Basic
09 106535 RK	LDMR	Low Density Multiple Reside	SFR-Basic
09 106536 RK	LDMR	Low Density Multiple Reside	SFR-Basic
09 106537 RK	LDMR	Low Density Multiple Reside	SFR-Basic
09 106538 RK	LDMR	Low Density Multiple Reside	SFR-Basic
09 103433 RK	LDMR	Low Density Multiple Reside	SFR-Basic
09 103434 RK	LDMR	Low Density Multiple Reside	SFR-Basic
09 103435 RK	LDMR	Low Density Multiple Reside	SFR-Basic
09 103436 RK	LDMR	Low Density Multiple Reside	SFR-Basic
09 101821 RK	LDMR	Low Density Multiple Reside	SFR-Basic
09 101822 RK	LDMR	Low Density Multiple Reside	SFR-Basic
09 101823 RK	LDMR	Low Density Multiple Reside	SFR-Basic
09 102688 RK	LDMR	Low Density Multiple Reside	SFR-Basic

Accessory Dwelling Units

Index # - File Name: 1.0022 - Single Family Dwellings Data\_Snohomish County.pdf

09 101833 RK	LDMR	Low Density Multiple Reside	SFR-Basic
09 101834 RK	LDMR	Low Density Multiple Reside	SFR-Basic
09 101835 RK	LDMR	Low Density Multiple Reside	SFR-Basic
09 101836 RK	LDMR	Low Density Multiple Reside	SFR-Basic
09 101837 RK	LDMR	Low Density Multiple Reside	SFR-Basic
09 101838 RK	LDMR	Low Density Multiple Reside	SFR-Basic
09 101839 RK	LDMR	Low Density Multiple Reside	SFR-Basic
09 101840 RK	LDMR	Low Density Multiple Reside	SFR-Basic
09 106289 RK	LDMR	Low Density Multiple Reside	SFR-Basic
09 106290 RK	LDMR	Low Density Multiple Reside	SFR-Basic
09 101841 RK	LDMR	Low Density Multiple Reside	SFR-Basic
09 101842 RK	LDMR	Low Density Multiple Reside	SFR-Basic
09 104057 RK	R-7,200	Residential 7,200 sq. ft.	Single Family Residential
09 103542 RK	R-5	Rural-5 Acre	SFR-Basic
09 104054 RK	R-7,200	Residential 7,200 sq. ft.	Single Family Residential
09 104056 RK	R-7,200	Residential 7,200 sq. ft.	Single Family Residential
09 103297 RK	R-7,200	Residential 7,200 sq. ft.	SFR-Basic
09 100650 RK	R-7,200	Residential 7,200 sq. ft.	SFR-Basic
09 108428 RK	R-7,200	Residential 7,200 sq. ft.	SFR-Basic
09 108122 RK	R-7,200	Residential 7,200 sq. ft.	SFR-Basic
09 103299 RK	R-7,200	Residential 7,200 sq. ft.	SFR-Basic
09 103300 RK	R-7,200	Residential 7,200 sq. ft.	SFR-Basic
09 106349 RK	R-7,200	Residential 7,200 sq. ft.	SFR-Basic
09 106350 RK	R-7,200	Residential 7,200 sq. ft.	SFR-Basic
09 101638 RK	R-7,200	Residential 7,200 sq. ft.	SFR-Basic
07 110254 000 01 RK	CITY	City	SFR-Basic
07 110256 000 01 RK	CITY	City	SFR-Basic
09 100811 RK	R-7,200	Residential 7,200 sq. ft.	Duplex-Combo
09 100652 RK	R-7,200	Residential 7,200 sq. ft.	SFR-Basic
09 100651 RK	R-7,200	Residential 7,200 sq. ft.	SFR-Basic
09 101640 RK	R-7,200	Residential 7,200 sq. ft.	SFR-Basic
09 101639 RK	R-7,200	Residential 7,200 sq. ft.	SFR-Basic
09 101641 RK	R-7,200	Residential 7,200 sq. ft.	SFR-Basic
09 107228 RK	R-7,200(PRD)	Residential 7,200 sq. ft.	SFR-Basic
09 107020 RK	R-7,200(PRD)	Residential 7,200 sq. ft.	SFR-Basic
09 107021 RK	R-7,200(PRD)	Residential 7,200 sq. ft.	SFR-Basic
09 107042 RK	R-7,200(PRD)	Residential 7,200 sq. ft.	SFR-Basic
09 107043 RK	R-7,200(PRD)	Residential 7,200 sq. ft.	SFR-Basic
09 107044 RK	R-7,200(PRD)	Residential 7,200 sq. ft.	SFR-Basic
09 107045 RK	R-7,200(PRD)	Residential 7,200 sq. ft.	SFR-Basic
09 107046 RK	R-7,200(PRD)	Residential 7,200 sq. ft.	SFR-Basic
09 107047 RK	R-7,200(PRD)	Residential 7,200 sq. ft.	SFR-Basic
09 107048 RK	R-7,200(PRD)	Residential 7,200 sq. ft.	SFR-Basic
09 107030 RK	R-7,200(PRD)	Residential 7,200 sq. ft.	SFR-Basic
09 107031 RK	R-7,200(PRD)	Residential 7,200 sq. ft.	SFR-Basic
09 107032 RK	R-7,200(PRD)	Residential 7,200 sq. ft.	SFR-Basic
09 107033 RK	R-7,200(PRD)	Residential 7,200 sq. ft.	SFR-Basic

Accessory Dwelling Units

Index # - File Name: 1.0022 - Single Family Dwellings Data\_Snohomish County.pdf

09 107034 RK	R-7,200(PRD)	Residential 7,200 sq. ft.	SFR-Basic
09 107035 RK	R-7,200(PRD)	Residential 7,200 sq. ft.	SFR-Basic
09 107036 RK	R-7,200(PRD)	Residential 7,200 sq. ft.	SFR-Basic
09 107037 RK	R-7,200(PRD)	Residential 7,200 sq. ft.	SFR-Basic
09 107038 RK	R-7,200(PRD)	Residential 7,200 sq. ft.	SFR-Basic
09 107039 RK	R-7,200(PRD)	Residential 7,200 sq. ft.	SFR-Basic
09 107040 RK	R-7,200(PRD)	Residential 7,200 sq. ft.	SFR-Basic
09 107041 RK	R-7,200(PRD)	Residential 7,200 sq. ft.	SFR-Basic
08 110387 RK	MR	Multiple Residential	Single Family Res-Combo
08 111202 RK	MR	Multiple Residential	Single Family Res-Combo
08 111203 RK	MR	Multiple Residential	Single Family Res-Combo
09 103927 RK	R-7,200	Residential 7,200 sq. ft.	Single Family Residential
09 103647 RK	R-5	Rural-5 Acre	Single Family Residential
09 103923 RK	R-7,200	Residential 7,200 sq. ft.	Single Family Residential
08 108169 RK	R-5	Rural-5 Acre	Single Family Res-Combo
09 104185 RK	R-7,200	Residential 7,200 sq. ft.	SFR-Basic
09 103819 RK	R-7,200	Residential 7,200 sq. ft.	SFR-Basic
09 104512 RK	R-7,200	Residential 7,200 sq. ft.	SFR-Basic
09 103577 RK	R-7,200	Residential 7,200 sq. ft.	SFR-Basic
09 105132 RK	R-7,200	Residential 7,200 sq. ft.	SFR-Basic
09 103820 RK	R-7,200	Residential 7,200 sq. ft.	SFR-Basic
09 104680 RK	R-7,200	Residential 7,200 sq. ft.	SFR-Basic
09 103814 RK	R-7,200	Residential 7,200 sq. ft.	SFR-Basic
09 104184 RK	R-7,200	Residential 7,200 sq. ft.	SFR-Basic
09 103575 RK	R-7,200	Residential 7,200 sq. ft.	SFR-Basic
09 105130 RK	R-7,200	Residential 7,200 sq. ft.	SFR-Basic
09 103576 RK	R-7,200	Residential 7,200 sq. ft.	SFR-Basic
09 105131 RK	R-7,200	Residential 7,200 sq. ft.	SFR-Basic
09 103818 RK	R-7,200	Residential 7,200 sq. ft.	SFR-Basic
09 103813 RK	R-7,200	Residential 7,200 sq. ft.	SFR-Basic
09 106294 RK	R-7,200	Residential 7,200 sq. ft.	SFR-Basic
09 106244 RK	R-7,200	Residential 7,200 sq. ft.	SFR-Basic
09 106245 RK	R-7,200	Residential 7,200 sq. ft.	SFR-Basic
09 106246 RK	R-7,200	Residential 7,200 sq. ft.	SFR-Basic
09 106295 RK	R-7,200	Residential 7,200 sq. ft.	SFR-Basic
09 106296 RK	R-7,200	Residential 7,200 sq. ft.	SFR-Basic
09 106247 RK	R-7,200	Residential 7,200 sq. ft.	SFR-Basic
09 107123 RK	R-7,200(PRD)	Residential 7,200 sq. ft.	SFR-Basic
09 106861 RK	R-7,200(PRD)	Residential 7,200 sq. ft.	SFR-Basic
09 106543 RK	R-7,200(PRD)	Residential 7,200 sq. ft.	SFR-Basic
09 107775 RK	R-7,200(PRD)	Residential 7,200 sq. ft.	SFR-Basic
09 106544 RK	R-7,200(PRD)	Residential 7,200 sq. ft.	SFR-Basic
09 107124 RK	R-7,200(PRD)	Residential 7,200 sq. ft.	SFR-Basic
09 104509 RK	R-7,200(PRD)	Residential 7,200 sq. ft.	SFR-Basic
09 103816 RK	R-7,200(PRD)	Residential 7,200 sq. ft.	SFR-Basic
09 105832 RK	R-7,200(PRD)	Residential 7,200 sq. ft.	SFR-Basic
09 105833 RK	R-7,200(PRD)	Residential 7,200 sq. ft.	SFR-Basic

Accessory Dwelling Units

Index # - File Name: 1.0022 - Single Family Dwellings Data\_Snohomish County.pdf

09 103817 RK	R-7,200(PRD)	Residential 7,200 sq. ft.	SFR-Basic
09 102804 RK	R-7,200(PRD)	Residential 7,200 sq. ft.	SFR-Basic
09 106998 RK	R-7,200	Residential 7,200 sq. ft.	Single Family Residential
09 105542 RK	R-7,200	Residential 7,200 sq. ft.	SFR-Basic
09 107005 RK	R-7,200	Residential 7,200 sq. ft.	SFR-Basic
09 101936 RK	LDMR	Low Density Multiple Reside	Single Family Res-Combo
09 105858 RK	LDMR	Low Density Multiple Reside	Single Family Residential
09 105850 RK	LDMR	Low Density Multiple Reside	Single Family Residential
09 101938 RK	LDMR	Low Density Multiple Reside	Single Family Res-Combo
09 105861 RK	LDMR	Low Density Multiple Reside	Single Family Residential
09 101937 RK	LDMR	Low Density Multiple Reside	Single Family Res-Combo
09 100734 RK	R-5	Rural-5 Acre	SFR-Basic
09 104667 RK	R-5	Rural-5 Acre	SFR-Basic
09 104666 RK	R-5	Rural-5 Acre	SFR-Basic
09 104665 RK	R-5	Rural-5 Acre	SFR-Basic
09 100736 RK	R-5	Rural-5 Acre	SFR-Basic
08 110613 MH	RRT-10	Rural Resource Transition-10	(Double Wide
09 100449 RK	R-5	Rural-5 Acre	SFR-Basic
09 107146 RK	LDMR	Low Density Multiple Reside	SFR-Basic
09 107147 RK	LDMR	Low Density Multiple Reside	SFR-Basic
09 104833 RK	R-5	Rural-5 Acre	Single Family Residential
09 102338 RK	R-7,200	Residential 7,200 sq. ft.	Single Family Res-Combo
09 103388 RK	CITY	City	SFR-Basic
09 102295 RK	CITY	City	SFR-Basic
09 102294 RK	CITY	City	SFR-Basic
09 102291 RK	CITY	City	SFR-Basic
09 102293 RK	CITY	City	SFR-Basic
09 108892 RK	R-7,200(PRD)	Residential 7,200 sq. ft.	SFR-Basic
09 108895 RK	R-7,200	Residential 7,200 sq. ft.	SFR-Basic
09 107674 RK	R-7,200	Residential 7,200 sq. ft.	SFR-Basic
09 108189 RK	R-7,200	Residential 7,200 sq. ft.	SFR-Basic
09 107230 RK	R-7,200	Residential 7,200 sq. ft.	SFR-Basic
09 107231 RK	R-7,200	Residential 7,200 sq. ft.	SFR-Basic
09 107232 RK	R-7,200	Residential 7,200 sq. ft.	SFR-Basic
09 107233 RK	R-7,200	Residential 7,200 sq. ft.	SFR-Basic
09 104236 RK	R-5	Rural-5 Acre	Single Family Residential
09 108896 RK	R-7,200	Residential 7,200 sq. ft.	SFR-Basic
09 108190 RK	R-7,200	Residential 7,200 sq. ft.	SFR-Basic
09 108191 RK	R-7,200	Residential 7,200 sq. ft.	SFR-Basic
09 108192 RK	R-7,200	Residential 7,200 sq. ft.	SFR-Basic
09 108726 RK	CITY	City	SFR-Basic
09 107496 RK	CITY	City	SFR-Basic
09 107497 RK	CITY	City	SFR-Basic
09 107498 RK	CITY	City	SFR-Basic
09 107499 RK	CITY	City	SFR-Basic
09 107500 RK	CITY	City	SFR-Basic
09 107502 RK	CITY	City	SFR-Basic

Accessory Dwelling Units

Index # - File Name: 1.0022 - Single Family Dwellings Data\_Snohomish County.pdf

09 106334 RK	R-7,200	Residential 7,200 sq. ft.	Single Family Residential
09 108969 RK	LDMR	Low Density Multiple Reside	SFR-Basic
09 108970 RK	LDMR	Low Density Multiple Reside	SFR-Basic
09 106957 RK	LDMR	Low Density Multiple Reside	SFR-Basic
09 106958 RK	LDMR	Low Density Multiple Reside	Single Family Residential
09 102388 RK	R-5	Rural-5 Acre	Single Family Res-Combo
09 101373 RK	CITY	City	SFR-Basic
09 101377 RK	CITY	City	SFR-Basic
09 101376 RK	CITY	City	SFR-Basic
09 103319 RK	RD	Rural Diversification	Single Family Res-Combo
09 103612 RK	R-5	Rural-5 Acre	SFR-Basic
09 106890 RK	R-5	Rural-5 Acre	SFR-Basic
09 101137 RK	R-5	Rural-5 Acre	Single Family Res-Combo
08 102323 RK	R-5	Rural-5 Acre	Single Family Res-Combo
09 105301 RK	R-5	Rural-5 Acre	Single Family Residential
09 103888 RK	R-7,200	Residential 7,200 sq. ft.	SFR-Basic
09 106926 RK	R-7,200	Residential 7,200 sq. ft.	SFR-Basic
09 104172 RK	R-7,200	Residential 7,200 sq. ft.	SFR-Basic
09 106922 RK	R-7,200	Residential 7,200 sq. ft.	SFR-Basic
09 108151 RK	R-7,200	Residential 7,200 sq. ft.	SFR-Basic
09 102904 RK	R-7,200	Residential 7,200 sq. ft.	Single Family Res-Combo
09 108154 RK	R-7,200	Residential 7,200 sq. ft.	Single Family Residential
08 109184 RK	R-7,200	Residential 7,200 sq. ft.	Single Family Res-Combo
09 104174 RK	R-7,200	Residential 7,200 sq. ft.	SFR-Basic
09 103890 RK	R-7,200	Residential 7,200 sq. ft.	SFR-Basic
09 104177 RK	R-7,200	Residential 7,200 sq. ft.	SFR-Basic
09 108156 RK	R-7,200	Residential 7,200 sq. ft.	SFR-Basic
09 108150 RK	R-7,200	Residential 7,200 sq. ft.	SFR-Basic
09 103649 RK	R-5	Rural-5 Acre	Single Family Residential
09 101513 RK	R-7,200(PRD)	Residential 7,200 sq. ft.	SFR-Basic
09 100636 RK	R-7,200(PRD)	Residential 7,200 sq. ft.	SFR-Basic
08 111169 RK	R-7,200(PRD)	Residential 7,200 sq. ft.	SFR-Basic
09 100637 RK	R-7,200(PRD)	Residential 7,200 sq. ft.	SFR-Basic
09 101511 RK	R-7,200(PRD)	Residential 7,200 sq. ft.	SFR-Basic
09 101512 RK	R-7,200(PRD)	Residential 7,200 sq. ft.	SFR-Basic
08 111045 RK	R-7,200(PRD)	Residential 7,200 sq. ft.	SFR-Basic
08 111044 RK	R-7,200(PRD)	Residential 7,200 sq. ft.	SFR-Basic
09 106853 RK	PRD-9,600	Residential 9,600 sq. ft.	SFR-Basic
09 106854 RK	PRD-9,600	Residential 9,600 sq. ft.	SFR-Basic
09 106542 RK	PRD-9,600	Residential 9,600 sq. ft.	SFR-Basic
09 108008 RK	PRD-9,600	Residential 9,600 sq. ft.	SFR-Basic
09 108009 RK	PRD-9,600	Residential 9,600 sq. ft.	SFR-Basic
09 108006 RK	PRD-9,600	Residential 9,600 sq. ft.	SFR-Basic
09 108007 RK	PRD-9,600	Residential 9,600 sq. ft.	SFR-Basic
09 106855 RK	PRD-9,600	Residential 9,600 sq. ft.	SFR-Basic
09 108306 RK	MR	Multiple Residential	Single Family Residential
09 108308 RK	MR	Multiple Residential	Single Family Residential

Accessory Dwelling Units

Index # - File Name: 1.0022 - Single Family Dwellings Data\_Snohomish County.pdf

09 108311 RK	MR	Multiple Residential	Single Family Residential
09 101813 RK	MR	Multiple Residential	Single Family Res-Combo
09 101812 RK	MR	Multiple Residential	Single Family Res-Combo
09 100977 RK	MR	Multiple Residential	Single Family Res-Combo
09 100976 RK	MR	Multiple Residential	Single Family Res-Combo
09 100975 RK	MR	Multiple Residential	Single Family Res-Combo
09 100982 RK	MR	Multiple Residential	Single Family Res-Combo
09 100981 RK	MR	Multiple Residential	Single Family Res-Combo
09 100980 RK	MR	Multiple Residential	Single Family Res-Combo
09 107778 RK	MR	Multiple Residential	Single Family Residential
09 107779 RK	MR	Multiple Residential	Single Family Residential
09 107781 RK	MR	Multiple Residential	Single Family Residential
09 100791 RK	MR	Multiple Residential	Single Family Res-Combo
09 100792 RK	MR	Multiple Residential	Single Family Res-Combo
09 100795 RK	MR	Multiple Residential	Single Family Res-Combo
09 107783 RK	MR	Multiple Residential	Single Family Residential
09 107784 RK	MR	Multiple Residential	Single Family Residential
09 107785 RK	MR	Multiple Residential	Single Family Residential
09 103075 RK	MR	Multiple Residential	Single Family Res-Combo
09 103076 RK	MR	Multiple Residential	Single Family Res-Combo
09 103077 RK	MR	Multiple Residential	Single Family Res-Combo
09 103430 RK	MR	Multiple Residential	Single Family Res-Combo
09 103431 RK	MR	Multiple Residential	Single Family Res-Combo
09 103432 RK	MR	Multiple Residential	Single Family Res-Combo
08 110328 RK	CITY	City	Single Family Res-Combo
09 107404 RK	CITY	City	Single Family Residential
09 107399 RK	CITY	City	Single Family Residential
09 102392 RK	CITY	City	Single Family Res-Combo
09 105424 RK	CITY	City	Single Family Residential
09 108304 RK	MR	Multiple Residential	Single Family Residential
09 100790 RK	MR	Multiple Residential	Single Family Res-Combo
09 107780 RK	MR	Multiple Residential	Single Family Residential
09 100978 RK	MR	Multiple Residential	Single Family Res-Combo
09 101810 RK	MR	Multiple Residential	Single Family Res-Combo
09 107782 RK	MR	Multiple Residential	Single Family Residential
09 103074 RK	MR	Multiple Residential	Single Family Res-Combo
09 103429 RK	MR	Multiple Residential	Single Family Res-Combo
09 100983 RK	MR	Multiple Residential	Single Family Res-Combo
09 105852 RK	LDMR	Low Density Multiple Reside SFR-Basic	
09 105853 RK	LDMR	Low Density Multiple Reside SFR-Basic	
09 105854 RK	LDMR	Low Density Multiple Reside SFR-Basic	
09 106718 RK	LDMR	Low Density Multiple Reside SFR-Basic	
09 105851 RK	LDMR	Low Density Multiple Reside SFR-Basic	
09 108589 RK	R-7,200	Residential 7,200 sq. ft.	SFR-Basic
09 108590 RK	R-7,200	Residential 7,200 sq. ft.	SFR-Basic
09 104745 RK	R-7,200	Residential 7,200 sq. ft.	SFR-Basic
09 100297 RK	R-5	Rural-5 Acre	SFR-Basic

Accessory Dwelling Units

Index # - File Name: 1.0022 - Single Family Dwellings Data\_Snohomish County.pdf

09 101881 RK	R-7,200	Residential 7,200 sq. ft.	SFR-Basic
09 106689 RK	LDMR	Low Density Multiple Reside	Single Family Residential
09 106213 RK	R-7,200	Residential 7,200 sq. ft.	SFR-Basic
09 104213 RK	R-7,200	Residential 7,200 sq. ft.	SFR-Basic
09 104215 RK	R-7,200	Residential 7,200 sq. ft.	SFR-Basic
09 108585 RK	R-7,200	Residential 7,200 sq. ft.	SFR-Basic
09 106210 RK	R-7,200	Residential 7,200 sq. ft.	SFR-Basic
09 106211 RK	R-7,200	Residential 7,200 sq. ft.	SFR-Basic
09 106212 RK	R-7,200	Residential 7,200 sq. ft.	SFR-Basic
09 106214 RK	R-7,200	Residential 7,200 sq. ft.	SFR-Basic
09 104214 RK	R-7,200	Residential 7,200 sq. ft.	SFR-Basic
09 102235 RK	R-7,200	Residential 7,200 sq. ft.	SFR-Basic
09 103140 RK	R-7,200	Residential 7,200 sq. ft.	SFR-Basic
09 100535 RK	R-7,200	Residential 7,200 sq. ft.	SFR-Basic
09 105612 RK	R-7,200	Residential 7,200 sq. ft.	SFR-Basic
09 104391 RK	R-7,200	Residential 7,200 sq. ft.	SFR-Basic
09 108331 RK	R-7,200	Residential 7,200 sq. ft.	SFR-Basic
09 108494 RK	CITY	City	SFR-Basic
09 108486 RK	CITY	City	SFR-Basic
09 108489 RK	CITY	City	SFR-Basic
09 108481 RK	CITY	City	Single Family Residential
09 107733 RK	R-5	Rural-5 Acre	Single Family Residential
09 107505 RK	CITY	City	SFR-Basic
09 108893 RK	R-7,200	Residential 7,200 sq. ft.	SFR-Basic
09 105800 RK	R-7,200	Residential 7,200 sq. ft.	SFR-Basic
09 105801 RK	R-7,200	Residential 7,200 sq. ft.	SFR-Basic
09 105802 RK	R-7,200	Residential 7,200 sq. ft.	SFR-Basic
09 105803 RK	R-7,200	Residential 7,200 sq. ft.	SFR-Basic
09 107125 RK	R-5	Rural-5 Acre	Single Family Residential
08 108300 RK	A-10	Agriculture-10 Acre	Single Family Res-Combo
10 108203 RK	R-7,200(PRD)	Residential 7,200 sq. ft.	SFR-Basic
10 108204 RK	R-7,200(PRD)	Residential 7,200 sq. ft.	SFR-Basic
10 104732 RK	R-5	Rural-5 Acre	Single Family Residential
10 104731 RK	R-5	Rural-5 Acre	Single Family Residential
10 102515 RK	R-7,200(PRD)	Residential 7,200 sq. ft.	SFR-Basic
10 101270 RK	R-7,200(PRD)	Residential 7,200 sq. ft.	SFR-Basic
10 104371 RK	R-7,200(PRD)	Residential 7,200 sq. ft.	SFR-Basic
10 103023 RK	R-7,200(PRD)	Residential 7,200 sq. ft.	SFR-Basic
10 102366 RK	CITY	City	Single Family Residential
10 103728 RK	R-7,200	Residential 7,200 sq. ft.	SFR-Basic
10 103729 RK	R-7,200	Residential 7,200 sq. ft.	SFR-Basic
10 103730 RK	R-7,200	Residential 7,200 sq. ft.	SFR-Basic
10 103731 RK	R-7,200	Residential 7,200 sq. ft.	SFR-Basic
10 103732 RK	R-7,200	Residential 7,200 sq. ft.	SFR-Basic
10 103925 RK	R-7,200	Residential 7,200 sq. ft.	SFR-Basic
10 103348 RK	R-7,200	Residential 7,200 sq. ft.	SFR-Basic
10 103926 RK	R-7,200	Residential 7,200 sq. ft.	SFR-Basic

Accessory Dwelling Units

Index # - File Name: 1.0022 - Single Family Dwellings Data\_Snohomish County.pdf

10 103927 RK	R-7,200	Residential 7,200 sq. ft.	SFR-Basic
10 103928 RK	R-7,200	Residential 7,200 sq. ft.	SFR-Basic
10 103929 RK	R-7,200	Residential 7,200 sq. ft.	SFR-Basic
10 103930 RK	R-7,200	Residential 7,200 sq. ft.	SFR-Basic
10 103931 RK	R-7,200	Residential 7,200 sq. ft.	SFR-Basic
10 103932 RK	R-7,200	Residential 7,200 sq. ft.	SFR-Basic
10 103345 RK	R-7,200	Residential 7,200 sq. ft.	SFR-Basic
10 103346 RK	R-7,200	Residential 7,200 sq. ft.	SFR-Basic
10 103347 RK	R-7,200	Residential 7,200 sq. ft.	SFR-Basic
10 102423 RK	R-7,200	Residential 7,200 sq. ft.	SFR-Basic
10 102424 RK	R-7,200	Residential 7,200 sq. ft.	SFR-Basic
10 102426 RK	R-7,200	Residential 7,200 sq. ft.	SFR-Basic
10 102427 RK	R-7,200	Residential 7,200 sq. ft.	SFR-Basic
10 102428 RK	R-7,200	Residential 7,200 sq. ft.	SFR-Basic
10 102429 RK	R-7,200	Residential 7,200 sq. ft.	SFR-Basic
10 102036 RK	R-5	Rural-5 Acre	Single Family Residential
10 109103 RK	R-7,200	Residential 7,200 sq. ft.	Single Family Residential
10 102227 RK	R-7,200	Residential 7,200 sq. ft.	SFR-Basic
10 102229 RK	R-7,200	Residential 7,200 sq. ft.	SFR-Basic
10 107796 RK	R-7,200	Residential 7,200 sq. ft.	SFR-Basic
10 107135 RK	R-7,200	Residential 7,200 sq. ft.	SFR-Basic
10 107136 RK	R-7,200	Residential 7,200 sq. ft.	SFR-Basic
10 108193 RK	R-7,200	Residential 7,200 sq. ft.	SFR-Basic
10 108578 RK	R-7,200	Residential 7,200 sq. ft.	SFR-Basic
10 108194 RK	R-7,200	Residential 7,200 sq. ft.	SFR-Basic
10 104670 RK	R-5	Rural-5 Acre	Single Family Residential
10 102851 RK	R-5	Rural-5 Acre	Single Family Residential
10 104044 RK	R-9,600	Residential 9,600 sq. ft.	Single Family Residential
10 108969 RK	R-7,200	Residential 7,200 sq. ft.	Single Family Residential
10 103915 RK	R-5	Rural-5 Acre	Single Family Residential
10 103754 RK	R-5	Rural-5 Acre	Single Family Residential
10 106456 RK	R-7,200(PRD)	Residential 7,200 sq. ft.	Single Family Residential
10 104402 RK	R-7,200	Residential 7,200 sq. ft.	Single Family Residential
10 104922 RK	LDMR	Low Density Multiple Reside	SFR-Basic
10 104934 RK	LDMR	Low Density Multiple Reside	SFR-Basic
10 108570 RK	LDMR	Low Density Multiple Reside	SFR-Basic
10 104936 RK	LDMR	Low Density Multiple Reside	SFR-Basic
09 108802 RK	R-5	Rural-5 Acre	Single Family Residential
10 100049 RK	R-5	Rural-5 Acre	Single Family Residential
10 105946 RK	R-9,600	Residential 9,600 sq. ft.	SFR-Basic
10 105947 RK	R-9,600	Residential 9,600 sq. ft.	SFR-Basic
10 105948 RK	R-9,600	Residential 9,600 sq. ft.	SFR-Basic
10 105949 RK	R-9,600	Residential 9,600 sq. ft.	SFR-Basic
10 105950 RK	R-9,600	Residential 9,600 sq. ft.	SFR-Basic
10 104911 RK	R-5	Rural-5 Acre	SFR-Basic
10 106989 RK	R-7,200	Residential 7,200 sq. ft.	SFR-Basic
10 101320 RK	R-7,200	Residential 7,200 sq. ft.	SFR-Basic



Accessory Dwelling Units

Index # - File Name: 1.0022 - Single Family Dwellings Data\_Snohomish County.pdf

10 100462 RK	R-7,200	Residential 7,200 sq. ft.	SFR-Basic
09 108689 RK	R-7,200	Residential 7,200 sq. ft.	SFR-Basic
09 108690 RK	R-7,200	Residential 7,200 sq. ft.	SFR-Basic
10 106991 RK	R-7,200	Residential 7,200 sq. ft.	SFR-Basic
09 108691 RK	R-7,200	Residential 7,200 sq. ft.	SFR-Basic
10 102511 RK	R-7,200	Residential 7,200 sq. ft.	SFR-Basic
09 108754 RK	CITY	City	SFR-Basic
09 109066 RK	CITY	City	SFR-Basic
09 109007 RK	CITY	City	SFR-Basic
10 103584 RK	R-5	Rural-5 Acre	Single Family Residential
10 103588 RK	R-5	Rural-5 Acre	Single Family Residential
10 103586 RK	R-5	Rural-5 Acre	Single Family Residential
10 103585 RK	R-5	Rural-5 Acre	Single Family Residential
10 103583 RK	R-5	Rural-5 Acre	Single Family Residential
09 108244 RK	R-7,200	Residential 7,200 sq. ft.	SFR-Basic
10 100440 RK	R-7,200	Residential 7,200 sq. ft.	SFR-Basic
10 106577 RK	R-7,200	Residential 7,200 sq. ft.	Single Family Residential
10 106579 RK	R-7,200	Residential 7,200 sq. ft.	Single Family Residential
10 104803 RK	R-7,200	Residential 7,200 sq. ft.	SFR-Basic
10 102968 RK	R-7,200	Residential 7,200 sq. ft.	SFR-Basic
10 104799 RK	R-7,200	Residential 7,200 sq. ft.	Single Family Residential
10 104800 RK	R-7,200	Residential 7,200 sq. ft.	SFR-Basic
09 108086 RK	R-5	Rural-5 Acre	Single Family Residential
09 108692 RK	R-7,200	Residential 7,200 sq. ft.	SFR-Basic
10 101319 RK	R-7,200	Residential 7,200 sq. ft.	SFR-Basic
10 106995 RK	R-7,200	Residential 7,200 sq. ft.	Single Family Residential
10 106993 RK	R-7,200	Residential 7,200 sq. ft.	SFR-Basic
09 108897 RK	R-7,200(PRD)	Residential 7,200 sq. ft.	SFR-Basic
10 100045 RK	R-7,200(PRD)	Residential 7,200 sq. ft.	SFR-Basic
10 100047 RK	R-7,200(PRD)	Residential 7,200 sq. ft.	SFR-Basic
10 104372 RK	R-7,200(PRD)	Residential 7,200 sq. ft.	SFR-Basic
10 104373 RK	R-7,200(PRD)	Residential 7,200 sq. ft.	SFR-Basic
10 104374 RK	R-7,200(PRD)	Residential 7,200 sq. ft.	SFR-Basic
10 102512 RK	R-7,200(PRD)	Residential 7,200 sq. ft.	SFR-Basic
10 102513 RK	R-7,200(PRD)	Residential 7,200 sq. ft.	SFR-Basic
10 102514 RK	R-7,200(PRD)	Residential 7,200 sq. ft.	SFR-Basic
10 101214 RK	R-7,200(PRD)	Residential 7,200 sq. ft.	SFR-Basic
10 101215 RK	R-7,200(PRD)	Residential 7,200 sq. ft.	SFR-Basic
10 101788 RK	R-7,200(PRD)	Residential 7,200 sq. ft.	SFR-Basic
10 100234 RK	R-7,200(PRD)	Residential 7,200 sq. ft.	SFR-Basic
10 100046 RK	R-7,200(PRD)	Residential 7,200 sq. ft.	SFR-Basic
10 101216 RK	R-7,200(PRD)	Residential 7,200 sq. ft.	SFR-Basic
10 101271 RK	R-7,200(PRD)	Residential 7,200 sq. ft.	SFR-Basic
10 104369 RK	R-7,200(PRD)	Residential 7,200 sq. ft.	SFR-Basic
10 100893 RK	R-5	Rural-5 Acre	Single Family Residential
10 100324 RK	R-5	Rural-5 Acre	SFR-Basic
10 100322 RK	R-5	Rural-5 Acre	SFR-Basic

Accessory Dwelling Units

Index # - File Name: 1.0022 - Single Family Dwellings Data\_Snohomish County.pdf

10 100655 MH	R-5	Rural-5 Acre	Single Wide
10 100756 RK	R-5	Rural-5 Acre	Single Family Residential
10 103084 RK	R-5	Rural-5 Acre	Single Family Residential
10 104647 RK	R-7,200(PRD)	Residential 7,200 sq. ft.	SFR-Basic
10 104648 RK	R-7,200(PRD)	Residential 7,200 sq. ft.	SFR-Basic
10 107138 RK	R-7,200(PRD)	Residential 7,200 sq. ft.	SFR-Basic
10 107139 RK	R-7,200(PRD)	Residential 7,200 sq. ft.	SFR-Basic
10 104650 RK	R-7,200(PRD)	Residential 7,200 sq. ft.	SFR-Basic
10 104651 RK	R-7,200(PRD)	Residential 7,200 sq. ft.	SFR-Basic
10 104652 RK	R-7,200(PRD)	Residential 7,200 sq. ft.	SFR-Basic
10 103267 RK	R-7,200(PRD)	Residential 7,200 sq. ft.	SFR-Basic
10 103268 RK	R-7,200(PRD)	Residential 7,200 sq. ft.	SFR-Basic
10 103260 RK	R-7,200(PRD)	Residential 7,200 sq. ft.	SFR-Basic
10 103261 RK	R-7,200(PRD)	Residential 7,200 sq. ft.	SFR-Basic
10 101580 RK	R-7,200(PRD)	Residential 7,200 sq. ft.	SFR-Basic
10 103262 RK	R-7,200(PRD)	Residential 7,200 sq. ft.	SFR-Basic
10 103263 RK	R-7,200(PRD)	Residential 7,200 sq. ft.	SFR-Basic
10 102448 RK	R-7,200(PRD)	Residential 7,200 sq. ft.	SFR-Basic
10 102015 RK	R-7,200(PRD)	Residential 7,200 sq. ft.	SFR-Basic
10 101582 RK	R-7,200(PRD)	Residential 7,200 sq. ft.	SFR-Basic
10 101583 RK	R-7,200(PRD)	Residential 7,200 sq. ft.	SFR-Basic
10 102016 RK	R-7,200(PRD)	Residential 7,200 sq. ft.	SFR-Basic
10 101584 RK	R-7,200(PRD)	Residential 7,200 sq. ft.	SFR-Basic
10 103264 RK	R-7,200(PRD)	Residential 7,200 sq. ft.	SFR-Basic
10 103279 RK	R-7,200(PRD)	Residential 7,200 sq. ft.	SFR-Basic
10 103266 RK	R-7,200(PRD)	Residential 7,200 sq. ft.	SFR-Basic
10 104649 RK	R-7,200(PRD)	Residential 7,200 sq. ft.	SFR-Basic
10 105847 RK	MR	Multiple Residential	Duplex-Basic
10 106644 RK	R-7,200(PRD)	Residential 7,200 sq. ft.	Duplex-Basic
10 106645 RK	R-7,200(PRD)	Residential 7,200 sq. ft.	Duplex-Basic
10 106648 RK	R-7,200(PRD)	Residential 7,200 sq. ft.	SFR-Basic
10 106646 RK	R-7,200(PRD)	Residential 7,200 sq. ft.	Duplex-Basic
10 106647 RK	R-7,200(PRD)	Residential 7,200 sq. ft.	Duplex-Basic
10 106960 RK	R-5	Rural-5 Acre	Single Family Residential
10 106982 MH	A-10 : RRT-10	Agriculture-10 Acre : Rural R	Single Wide
10 108747 RK	R-7,200	Residential 7,200 sq. ft.	SFR-Basic
10 108748 RK	R-7,200	Residential 7,200 sq. ft.	SFR-Basic
10 108009 000 01 RK	R-7,200	Residential 7,200 sq. ft.	SFR-Basic
10 108010 000 01 RK	R-7,200	Residential 7,200 sq. ft.	SFR-Basic
10 100956 RK	R-5	Rural-5 Acre	Single Family Residential
10 100435 RK	R-7,200	Residential 7,200 sq. ft.	SFR-Basic
10 102259 RK	R-7,200	Residential 7,200 sq. ft.	SFR-Basic
10 107061 RK	LDMR	Low Density Multiple Reside	Single Family Residential
10 102260 RK	R-7,200	Residential 7,200 sq. ft.	SFR-Basic
10 103548 RK	R-7,200	Residential 7,200 sq. ft.	Single Family Residential
10 101554 RK	R-5	Rural-5 Acre	SFR-Basic
10 102160 RK	R-5	Rural-5 Acre	SFR-Basic

Accessory Dwelling Units

Index # - File Name: 1.0022 - Single Family Dwellings Data\_Snohomish County.pdf

10 107124 RK	R-5	Rural-5 Acre	SFR-Basic
10 107127 RK	R-5	Rural-5 Acre	SFR-Basic
10 107128 RK	R-5	Rural-5 Acre	SFR-Basic
10 106495 RK	R-5	Rural-5 Acre	SFR-Basic
09 108490 RK	CITY	City	SFR-Basic
09 108488 RK	CITY	City	SFR-Basic
09 108491 RK	CITY	City	SFR-Basic
09 108485 RK	CITY	City	SFR-Basic
09 108484 RK	CITY	City	SFR-Basic
09 108492 RK	CITY	City	SFR-Basic
09 108487 RK	CITY	City	SFR-Basic
09 108493 RK	CITY	City	SFR-Basic
10 106703 RK	R-7,200	Residential 7,200 sq. ft.	SFR-Basic
10 104874 RK	R-7,200	Residential 7,200 sq. ft.	SFR-Basic
10 109070 RK	R-7,200	Residential 7,200 sq. ft.	SFR-Basic
10 106704 RK	R-7,200	Residential 7,200 sq. ft.	SFR-Basic
10 107119 RK	R-7,200	Residential 7,200 sq. ft.	SFR-Basic
10 102706 RK	R-7,200	Residential 7,200 sq. ft.	SFR-Basic
08 105221 RK	WFB	Waterfront Beach	Single Family Res-Combo
08 105224 RK	WFB	Waterfront Beach	Single Family Res-Combo
08 102080 000 01 RK	R-5	Rural-5 Acre	Single Family Res-Combo
08 102079 000 01 RK	R-5	Rural-5 Acre	Single Family Res-Combo
10 106686 RK	R-8,400	Residential 8,400 sq. ft.	SFR-Basic
10 105042 RK	R-8,400	Residential 8,400 sq. ft.	SFR-Basic
10 100169 RK	MR	Multiple Residential	Single Family Residential
10 101963 RK	R-7,200	Residential 7,200 sq. ft.	Single Family Residential
10 104833 RK	MR	Multiple Residential	Single Family Residential
10 100820 RK	MR	Multiple Residential	Single Family Residential
09 107808 RK	CITY	City	Single Family Residential
08 110324 000 01 RK	CITY	City	Single Family Res-Combo
10 100171 RK	MR	Multiple Residential	Single Family Residential
10 100172 RK	MR	Multiple Residential	Single Family Residential
10 100173 RK	MR	Multiple Residential	Single Family Residential
10 100821 RK	MR	Multiple Residential	Single Family Residential
10 100823 RK	MR	Multiple Residential	Single Family Residential
10 100824 RK	MR	Multiple Residential	Single Family Residential
10 104835 RK	MR	Multiple Residential	Single Family Residential
10 104838 RK	MR	Multiple Residential	Single Family Residential
09 109229 RK	PRD-9,600	Residential 9,600 sq. ft.	SFR-Basic
10 102077 RK	PRD-9,600	Residential 9,600 sq. ft.	SFR-Basic
09 108224 RK	PRD-9,600	Residential 9,600 sq. ft.	SFR-Basic
10 102078 RK	PRD-9,600	Residential 9,600 sq. ft.	SFR-Basic
10 102079 RK	PRD-9,600	Residential 9,600 sq. ft.	SFR-Basic
10 102162 RK	PRD-9,600	Residential 9,600 sq. ft.	SFR-Basic
10 102167 RK	PRD-9,600	Residential 9,600 sq. ft.	Single Family Residential
10 102165 RK	PRD-9,600	Residential 9,600 sq. ft.	Single Family Residential
10 102161 RK	PRD-9,600	Residential 9,600 sq. ft.	SFR-Basic

Accessory Dwelling Units

Index # - File Name: 1.0022 - Single Family Dwellings Data\_Snohomish County.pdf

10 102168 RK	PRD-9,600	Residential 9,600 sq. ft.	Single Family Residential
10 101692 RK	PRD-9,600	Residential 9,600 sq. ft.	Single Family Residential
09 109228 RK	PRD-9,600	Residential 9,600 sq. ft.	SFR-Basic
09 108225 RK	PRD-9,600	Residential 9,600 sq. ft.	SFR-Basic
10 102080 RK	PRD-9,600	Residential 9,600 sq. ft.	SFR-Basic
09 109232 RK	PRD-9,600	Residential 9,600 sq. ft.	SFR-Basic
08 106840 000 01 RK	R-7,200	Residential 7,200 sq. ft.	Single Family Res-Combo
10 105601 RK	R-7,200	Residential 7,200 sq. ft.	SFR-Basic
10 105602 RK	R-7,200	Residential 7,200 sq. ft.	SFR-Basic
10 105603 RK	R-7,200	Residential 7,200 sq. ft.	SFR-Basic
10 105604 RK	R-7,200	Residential 7,200 sq. ft.	SFR-Basic
10 105605 RK	R-7,200	Residential 7,200 sq. ft.	SFR-Basic
10 105653 RK	R-7,200	Residential 7,200 sq. ft.	Single Family Residential
10 105654 RK	R-7,200	Residential 7,200 sq. ft.	Single Family Residential
10 102188 RK	R-7,200	Residential 7,200 sq. ft.	SFR-Basic
10 107218 000 01 RK	R-5	Rural-5 Acre	Single Family Residential
10 101395 RK	R-7,200	Residential 7,200 sq. ft.	Single Family Residential
10 101399 RK	R-7,200	Residential 7,200 sq. ft.	Single Family Residential
09 100186 000 01 RK	R-5	Rural-5 Acre	Single Family Res-Combo
10 100254 RK	MR	Multiple Residential	Duplex
10 105906 RK	R-7,200	Residential 7,200 sq. ft.	Single Family Residential
10 105908 RK	R-7,200	Residential 7,200 sq. ft.	Single Family Residential
10 100724 RK	R-7,200	Residential 7,200 sq. ft.	SFR-Basic
10 101973 RK	R-7,200	Residential 7,200 sq. ft.	SFR-Basic
08 107592 000 01 RK	R-7,200	Residential 7,200 sq. ft.	Single Family Res-Combo
10 105909 RK	R-7,200	Residential 7,200 sq. ft.	Single Family Residential
10 100739 RK	R-7,200	Residential 7,200 sq. ft.	SFR-Basic
10 104467 RK	R-7,200	Residential 7,200 sq. ft.	Single Family Residential
10 104292 RK	R-7,200	Residential 7,200 sq. ft.	Single Family Residential
10 103016 RK	R-5	Rural-5 Acre	SFR-Basic
10 107662 RK	R-5	Rural-5 Acre	SFR-Basic
10 108610 RK	R-5	Rural-5 Acre	Single Family Residential
10 100315 RK	R-5	Rural-5 Acre	SFR-Basic
10 105504 RK	R-5	Rural-5 Acre	SFR-Basic
10 100323 RK	R-5	Rural-5 Acre	SFR-Basic
08 108069 000 01 RK	R-5	Rural-5 Acre	Single Family Res-Combo
08 107021 000 01 RK	R-5	Rural-5 Acre	Single Family Res-Combo
10 100316 RK	R-5	Rural-5 Acre	SFR-Basic
10 103015 RK	R-5	Rural-5 Acre	Single Family Residential
10 102503 RK	A-10	Agriculture-10 Acre	Single Family Residential
10 105966 RK	R-5	Rural-5 Acre	SFR-Basic
09 109117 RK	R-5	Rural-5 Acre	SFR-Basic
09 101374 000 01 RK	CITY	City	SFR-Basic
10 109264 RK	LDMR	Low Density Multiple Reside	Single Family Residential
10 109265 RK	LDMR	Low Density Multiple Reside	Single Family Residential
10 109262 RK	LDMR	Low Density Multiple Reside	Single Family Residential
10 109270 RK	LDMR	Low Density Multiple Reside	Single Family Residential

Accessory Dwelling Units

Index # - File Name: 1.0022 - Single Family Dwellings Data\_Snohomish County.pdf

10 109263 RK	LDMR	Low Density Multiple Reside	Single Family Residential
10 109267 RK	LDMR	Low Density Multiple Reside	Single Family Residential
10 109266 RK	LDMR	Low Density Multiple Reside	Single Family Residential
09 105552 RK	R-5	Rural-5 Acre	Single Family Residential
10 102144 RK	R-7,200	Residential 7,200 sq. ft.	SFR-Basic
10 104383 RK	R-7,200	Residential 7,200 sq. ft.	SFR-Basic
10 100043 RK	R-7,200	Residential 7,200 sq. ft.	SFR-Basic
09 109080 RK	CITY	City	SFR-Basic
10 101259 RK	R-5	Rural-5 Acre	SFR-Basic
10 103695 RK	R-5	Rural-5 Acre	SFR-Basic
10 103696 RK	R-5	Rural-5 Acre	SFR-Basic
10 101264 RK	R-5	Rural-5 Acre	SFR-Basic
10 104862 RK	R-5	Rural-5 Acre	SFR-Basic
10 104864 RK	R-5	Rural-5 Acre	SFR-Basic
10 103697 RK	R-5	Rural-5 Acre	SFR-Basic
10 101263 RK	R-5	Rural-5 Acre	SFR-Basic
10 101261 RK	R-5	Rural-5 Acre	SFR-Basic
10 104859 RK	R-5	Rural-5 Acre	SFR-Basic
10 104860 RK	R-5	Rural-5 Acre	SFR-Basic
10 104861 RK	R-5	Rural-5 Acre	SFR-Basic
10 103698 RK	R-5	Rural-5 Acre	SFR-Basic
09 104827 RK	F	Forestry	Single Family Residential
10 109268 RK	LDMR	Low Density Multiple Reside	Single Family Residential
10 106776 RK	R-5	Rural-5 Acre	Single Family Residential
10 103634 RK	R-5	Rural-5 Acre	SFR-Basic
10 100656 RK	R-5	Rural-5 Acre	Single Family Residential
10 104599 RK	R-5	Rural-5 Acre	SFR-Basic
10 104605 RK	R-5	Rural-5 Acre	SFR-Basic
09 108239 RK	R-5	Rural-5 Acre	SFR-Basic
10 100659 RK	R-5	Rural-5 Acre	Single Family Residential
10 101852 RK	R-5	Rural-5 Acre	SFR-Basic
10 100227 RK	R-5	Rural-5 Acre	SFR-Basic
10 103909 RK	R-5	Rural-5 Acre	SFR-Basic
09 105426 RK	LDMR	Low Density Multiple Reside	Single Family Residential
10 103001 RK	LDMR	Low Density Multiple Reside	Single Family Residential
09 105855 RK	LDMR	Low Density Multiple Reside	Single Family Residential
09 105857 RK	LDMR	Low Density Multiple Reside	Single Family Residential
10 100183 RK	R-7,200	Residential 7,200 sq. ft.	SFR-Basic
10 108852 RK	R-7,200	Residential 7,200 sq. ft.	SFR-Basic
10 108853 RK	R-7,200	Residential 7,200 sq. ft.	SFR-Basic
10 108851 RK	R-7,200	Residential 7,200 sq. ft.	SFR-Basic
10 102471 RK	R-7,200(PRD)	Residential 7,200 sq. ft.	SFR-Basic
09 108445 RK	R-7,200(PRD)	Residential 7,200 sq. ft.	SFR-Basic
09 108446 RK	R-7,200(PRD)	Residential 7,200 sq. ft.	SFR-Basic
09 108710 RK	R-7,200(PRD)	Residential 7,200 sq. ft.	SFR-Basic
09 108711 RK	R-7,200(PRD)	Residential 7,200 sq. ft.	SFR-Basic
10 108854 RK	R-7,200	Residential 7,200 sq. ft.	SFR-Basic

Accessory Dwelling Units

Index # - File Name: 1.0022 - Single Family Dwellings Data\_Snohomish County.pdf

10 104960 RK	R-7,200	Residential 7,200 sq. ft.	SFR-Basic
10 104961 RK	R-7,200	Residential 7,200 sq. ft.	SFR-Basic
10 104962 RK	R-7,200	Residential 7,200 sq. ft.	SFR-Basic
10 100689 RK	R-7,200	Residential 7,200 sq. ft.	SFR-Basic
10 100997 RK	R-7,200	Residential 7,200 sq. ft.	SFR-Basic
10 100998 RK	R-7,200	Residential 7,200 sq. ft.	SFR-Basic
10 101000 RK	R-7,200	Residential 7,200 sq. ft.	SFR-Basic
10 103439 RK	R-7,200	Residential 7,200 sq. ft.	SFR-Basic
10 100688 RK	R-7,200	Residential 7,200 sq. ft.	SFR-Basic
10 100996 RK	R-7,200	Residential 7,200 sq. ft.	SFR-Basic
10 100999 RK	R-7,200	Residential 7,200 sq. ft.	SFR-Basic
10 101001 RK	R-7,200	Residential 7,200 sq. ft.	SFR-Basic
10 103440 RK	R-7,200	Residential 7,200 sq. ft.	SFR-Basic
10 100961 RK	R-7,200	Residential 7,200 sq. ft.	Single Family Residential
10 100960 RK	R-7,200	Residential 7,200 sq. ft.	Single Family Residential
10 104451 RK	R-7,200	Residential 7,200 sq. ft.	Single Family Residential
10 101843 RK	R-7,200	Residential 7,200 sq. ft.	Single Family Residential
10 103041 RK	R-7,200	Residential 7,200 sq. ft.	Single Family Residential
10 101967 RK	R-7,200	Residential 7,200 sq. ft.	Single Family Residential
10 102068 RK	R-7,200	Residential 7,200 sq. ft.	Single Family Residential
10 102069 RK	R-7,200	Residential 7,200 sq. ft.	Single Family Residential
10 103037 RK	R-7,200	Residential 7,200 sq. ft.	Single Family Residential
10 103038 RK	R-7,200	Residential 7,200 sq. ft.	Single Family Residential
10 103039 RK	R-7,200	Residential 7,200 sq. ft.	Single Family Residential
10 103040 RK	R-7,200	Residential 7,200 sq. ft.	Single Family Residential
10 104955 RK	R-7,200	Residential 7,200 sq. ft.	SFR-Basic
10 104956 RK	R-7,200	Residential 7,200 sq. ft.	SFR-Basic
10 104957 RK	R-7,200	Residential 7,200 sq. ft.	SFR-Basic
10 104958 RK	R-7,200	Residential 7,200 sq. ft.	SFR-Basic
10 100094 RK	R-7,200(PRD)	Residential 7,200 sq. ft.	SFR-Basic
10 100693 RK	R-7,200(PRD)	Residential 7,200 sq. ft.	SFR-Basic
10 102180 RK	R-7,200(PRD)	Residential 7,200 sq. ft.	SFR-Basic
10 101388 RK	R-7,200(PRD)	Residential 7,200 sq. ft.	SFR-Basic
09 100500 RK	R-7,200(PRD)	Residential 7,200 sq. ft.	SFR-Basic
10 104524 RK	R-7,200(PRD)	Residential 7,200 sq. ft.	SFR-Basic
10 107151 RK	RRT-10	Rural Resource Transition-10	Single Family Residential
10 100124 RK	R-5	Rural-5 Acre	SFR-Basic
10 100125 RK	R-5	Rural-5 Acre	SFR-Basic
10 100129 RK	R-5	Rural-5 Acre	SFR-Basic
10 100130 RK	R-5	Rural-5 Acre	SFR-Basic
10 100864 RK	R-5	Rural-5 Acre	SFR-Basic
10 100865 RK	R-5	Rural-5 Acre	SFR-Basic
10 101375 RK	R-5	Rural-5 Acre	SFR-Basic
10 101376 RK	R-5	Rural-5 Acre	SFR-Basic
10 101377 RK	R-5	Rural-5 Acre	SFR-Basic
10 101378 RK	R-5	Rural-5 Acre	SFR-Basic
10 101373 RK	R-5	Rural-5 Acre	SFR-Basic

Accessory Dwelling Units

Index # - File Name: 1.0022 - Single Family Dwellings Data\_Snohomish County.pdf

10 101374 RK	R-5	Rural-5 Acre	SFR-Basic
10 101379 RK	R-5	Rural-5 Acre	SFR-Basic
10 100126 RK	R-5	Rural-5 Acre	SFR-Basic
10 100862 RK	R-5	Rural-5 Acre	SFR-Basic
10 100863 RK	R-5	Rural-5 Acre	SFR-Basic
10 100123 RK	R-5	Rural-5 Acre	SFR-Basic
10 100127 RK	R-5	Rural-5 Acre	SFR-Basic
10 100128 RK	R-5	Rural-5 Acre	SFR-Basic
10 100122 RK	R-5	Rural-5 Acre	SFR-Basic
10 101113 RK	R-5	Rural-5 Acre	Single Family Residential
10 108508 RK	R-7,200(PRD)	Residential 7,200 sq. ft.	SFR-Basic
10 103350 RK	R-7,200(PRD)	Residential 7,200 sq. ft.	SFR-Basic
10 103352 RK	R-7,200(PRD)	Residential 7,200 sq. ft.	SFR-Basic
10 108114 RK	R-7,200(PRD)	Residential 7,200 sq. ft.	SFR-Basic
10 103351 RK	R-7,200(PRD)	Residential 7,200 sq. ft.	SFR-Basic
10 108807 RK	R-7,200(PRD)	Residential 7,200 sq. ft.	SFR-Basic
10 103349 RK	R-7,200(PRD)	Residential 7,200 sq. ft.	SFR-Basic
10 102575 RK	R-7,200	Residential 7,200 sq. ft.	SFR-Basic
10 103767 RK	R-7,200	Residential 7,200 sq. ft.	SFR-Basic
10 103766 RK	R-7,200	Residential 7,200 sq. ft.	SFR-Basic
10 101064 RK	R-7,200	Residential 7,200 sq. ft.	SFR-Basic
10 101062 RK	R-7,200	Residential 7,200 sq. ft.	SFR-Basic
10 101061 RK	R-7,200	Residential 7,200 sq. ft.	SFR-Basic
10 103112 RK	R-7,200	Residential 7,200 sq. ft.	SFR-Basic
10 103765 RK	R-7,200	Residential 7,200 sq. ft.	SFR-Basic
10 100955 RK	R-7,200	Residential 7,200 sq. ft.	Single Family Residential
10 104452 RK	R-7,200	Residential 7,200 sq. ft.	Single Family Residential
10 102070 RK	R-7,200	Residential 7,200 sq. ft.	Single Family Residential
10 102071 RK	R-7,200	Residential 7,200 sq. ft.	Single Family Residential
10 102072 RK	R-7,200	Residential 7,200 sq. ft.	Single Family Residential
10 102073 RK	R-7,200	Residential 7,200 sq. ft.	Single Family Residential
10 103951 RK	LDMR	Low Density Multiple Reside	SFR-Basic
10 103952 RK	LDMR	Low Density Multiple Reside	SFR-Basic
10 103953 RK	LDMR	Low Density Multiple Reside	SFR-Basic
10 101443 RK	LDMR	Low Density Multiple Reside	SFR-Basic
10 101444 RK	LDMR	Low Density Multiple Reside	SFR-Basic
10 103944 RK	LDMR	Low Density Multiple Reside	SFR-Basic
10 103945 RK	LDMR	Low Density Multiple Reside	SFR-Basic
10 103946 RK	LDMR	Low Density Multiple Reside	SFR-Basic
10 103947 RK	LDMR	Low Density Multiple Reside	SFR-Basic
10 102374 RK	LDMR	Low Density Multiple Reside	SFR-Basic
10 102375 RK	LDMR	Low Density Multiple Reside	SFR-Basic
10 102376 RK	LDMR	Low Density Multiple Reside	SFR-Basic
10 101432 RK	LDMR	Low Density Multiple Reside	SFR-Basic
10 101433 RK	LDMR	Low Density Multiple Reside	SFR-Basic
10 101434 RK	LDMR	Low Density Multiple Reside	SFR-Basic
10 101435 RK	LDMR	Low Density Multiple Reside	SFR-Basic

Accessory Dwelling Units

Index # - File Name: 1.0022 - Single Family Dwellings Data\_Snohomish County.pdf

10 101436 RK	LDMR	Low Density Multiple Reside	SFR-Basic
10 100576 RK	LDMR	Low Density Multiple Reside	SFR-Basic
10 102377 RK	LDMR	Low Density Multiple Reside	SFR-Basic
10 102378 RK	LDMR	Low Density Multiple Reside	SFR-Basic
10 102379 RK	LDMR	Low Density Multiple Reside	SFR-Basic
10 101437 RK	LDMR	Low Density Multiple Reside	SFR-Basic
10 101438 RK	LDMR	Low Density Multiple Reside	SFR-Basic
10 101439 RK	LDMR	Low Density Multiple Reside	SFR-Basic
10 101440 RK	LDMR	Low Density Multiple Reside	SFR-Basic
10 101441 RK	LDMR	Low Density Multiple Reside	SFR-Basic
10 101442 RK	LDMR	Low Density Multiple Reside	SFR-Basic
10 108276 RK	R-5	Rural-5 Acre	Single Family Residential
09 108559 RK	CITY	City	SFR-Basic
09 108178 RK	CITY	City	SFR-Basic
09 108176 RK	CITY	City	SFR-Basic
09 108558 RK	CITY	City	SFR-Basic
09 108562 RK	CITY	City	SFR-Basic
09 108560 RK	CITY	City	SFR-Basic
09 108561 RK	CITY	City	SFR-Basic
10 100039 RK	CITY	City	SFR-Basic
08 105921 000 01 RK	UC	Urban Center	Single Family Res-Combo
10 102414 RK	R-9,600	Residential 9,600 sq. ft.	SFR-Basic
10 102415 RK	R-9,600	Residential 9,600 sq. ft.	SFR-Basic
10 104301 RK			SFR-Basic
10 100691 RK	R-7,200(PRD)	Residential 7,200 sq. ft.	SFR-Basic
10 104503 RK	R-7,200(PRD)	Residential 7,200 sq. ft.	SFR-Basic
10 101762 RK	R-7,200(PRD)	Residential 7,200 sq. ft.	SFR-Basic
10 101764 RK	R-7,200(PRD)	Residential 7,200 sq. ft.	SFR-Basic
10 101763 RK	R-7,200(PRD)	Residential 7,200 sq. ft.	SFR-Basic
10 102976 RK	MR	Multiple Residential	Duplex
10 104022 RK	R-7,200	Residential 7,200 sq. ft.	Single Family Residential
10 103070 RK	R-7,200(PRD)	Residential 7,200 sq. ft.	SFR-Basic
10 104920 RK	R-7,200(PRD)	Residential 7,200 sq. ft.	SFR-Basic
10 104872 RK	R-5	Rural-5 Acre	Single Family Residential
10 104028 RK	R-7,200	Residential 7,200 sq. ft.	Single Family Residential
10 101992 RK	R-7,200	Residential 7,200 sq. ft.	Single Family Residential
09 107087 RK	R-7,200	Residential 7,200 sq. ft.	Single Family Residential
10 104550 RK	R-7,200	Residential 7,200 sq. ft.	Single Family Residential
10 106913 RK	R-7,200	Residential 7,200 sq. ft.	Single Family Residential
10 104230 RK	R-9,600	Residential 9,600 sq. ft.	SFR-Basic
10 106197 RK	R-5	Rural-5 Acre	SFR-Basic
10 100650 RK	R-5	Rural-5 Acre	Single Family Residential
10 101082 RK	R-5	Rural-5 Acre	SFR-Basic
10 105027 RK	R-9,600	Residential 9,600 sq. ft.	SFR-Basic
10 105028 RK	R-9,600	Residential 9,600 sq. ft.	SFR-Basic
10 104928 RK	R-7,200(PRD)	Residential 7,200 sq. ft.	SFR-Basic
10 104921 RK	R-7,200(PRD)	Residential 7,200 sq. ft.	SFR-Basic



Accessory Dwelling Units

Index # - File Name: 1.0022 - Single Family Dwellings Data\_Snohomish County.pdf

10 103072 RK	R-7,200(PRD)	Residential 7,200 sq. ft.	SFR-Basic
10 103063 RK	R-7,200(PRD)	Residential 7,200 sq. ft.	SFR-Basic
10 103066 RK	R-7,200(PRD)	Residential 7,200 sq. ft.	SFR-Basic
10 102443 RK	R-7,200(PRD)	Residential 7,200 sq. ft.	SFR-Basic
08 102201 000 01 RK	R-8,400	Residential 8,400 sq. ft.	Single Family Res-Combo
10 101086 RK	R-5	Rural-5 Acre	Single Family Residential
10 102442 RK	R-7,200(PRD)	Residential 7,200 sq. ft.	SFR-Basic
10 102445 RK	R-7,200(PRD)	Residential 7,200 sq. ft.	SFR-Basic
10 105429 RK	R-7,200	Residential 7,200 sq. ft.	Single Family Residential
10 104749 RK	MR	Multiple Residential	SFR-Basic
10 104750 RK	MR	Multiple Residential	SFR-Basic
10 104744 RK	MR	Multiple Residential	SFR-Basic
10 104745 RK	MR	Multiple Residential	SFR-Basic
10 104746 RK	MR	Multiple Residential	SFR-Basic
10 104747 RK	MR	Multiple Residential	SFR-Basic
10 104748 RK	MR	Multiple Residential	SFR-Basic
10 104739 RK	MR	Multiple Residential	Single Family Residential
10 104740 RK	MR	Multiple Residential	Single Family Residential
10 104741 RK	MR	Multiple Residential	Single Family Residential
10 104742 RK	MR	Multiple Residential	Single Family Residential
10 104751 RK	MR	Multiple Residential	SFR-Basic
10 104040 RK	R-7,200	Residential 7,200 sq. ft.	SFR-Basic
10 104077 RK	R-5	Rural-5 Acre	Single Family Residential
10 103560 RK	R-5	Rural-5 Acre	Single Family Residential
10 108341 RK	R-5	Rural-5 Acre	Single Family Residential
10 107929 RK	R-5	Rural-5 Acre	Single Family Residential
10 104526 RK	R-7,200(PRD)	Residential 7,200 sq. ft.	SFR-Basic
10 107528 RK	R-7,200	Residential 7,200 sq. ft.	SFR-Basic
10 107736 RK	R-7,200	Residential 7,200 sq. ft.	SFR-Basic
10 106551 RK	R-5	Rural-5 Acre	Single Family Residential
10 103559 RK	R-5	Rural-5 Acre	Single Family Residential
10 108337 RK	R-5	Rural-5 Acre	Single Family Residential
10 104073 RK	R-5	Rural-5 Acre	Single Family Residential
10 108339 RK	R-5	Rural-5 Acre	Single Family Residential
10 103562 RK	R-5	Rural-5 Acre	Single Family Residential
10 108340 RK	R-5	Rural-5 Acre	Single Family Residential
10 102417 RK	R-9,600	Residential 9,600 sq. ft.	SFR-Basic
10 101659 RK	R-9,600	Residential 9,600 sq. ft.	SFR-Basic
10 101660 RK	R-9,600	Residential 9,600 sq. ft.	SFR-Basic
10 101661 RK	R-9,600	Residential 9,600 sq. ft.	SFR-Basic
10 101662 RK	R-9,600	Residential 9,600 sq. ft.	SFR-Basic
10 102089 RK	R-9,600	Residential 9,600 sq. ft.	SFR-Basic
10 102404 RK	R-9,600	Residential 9,600 sq. ft.	SFR-Basic
10 102405 RK	R-9,600	Residential 9,600 sq. ft.	SFR-Basic
10 101663 RK	R-9,600	Residential 9,600 sq. ft.	SFR-Basic
10 101664 RK	R-9,600	Residential 9,600 sq. ft.	SFR-Basic
10 102406 RK	R-9,600	Residential 9,600 sq. ft.	SFR-Basic

Accessory Dwelling Units

Index # - File Name: 1.0022 - Single Family Dwellings Data\_Snohomish County.pdf

10 103540 RK	R-9,600	Residential 9,600 sq. ft.	SFR-Basic
10 104788 RK	R-9,600	Residential 9,600 sq. ft.	SFR-Basic
10 103343 RK	R-9,600	Residential 9,600 sq. ft.	SFR-Basic
10 100725 RK	R-9,600	Residential 9,600 sq. ft.	SFR-Basic
10 102562 RK	R-9,600	Residential 9,600 sq. ft.	SFR-Basic
10 102563 RK	R-9,600	Residential 9,600 sq. ft.	SFR-Basic
10 102090 RK	R-9,600	Residential 9,600 sq. ft.	SFR-Basic
10 107125 RK	R-5	Rural-5 Acre	SFR-Basic
10 106496 RK	R-5	Rural-5 Acre	SFR-Basic
10 108133 RK	R-7,200	Residential 7,200 sq. ft.	SFR-Basic
10 108343 RK	R-7,200	Residential 7,200 sq. ft.	Single Family Residential
10 101743 RK	R-7,200	Residential 7,200 sq. ft.	SFR-Basic
10 101739 RK	R-7,200	Residential 7,200 sq. ft.	SFR-Basic
10 101740 RK	R-7,200	Residential 7,200 sq. ft.	SFR-Basic
10 104587 RK	R-7,200	Residential 7,200 sq. ft.	Duplex
08 106960 000 01 RK	R-5	Rural-5 Acre	Single Family Res-Combo
10 100984 RK	R-9,600	Residential 9,600 sq. ft.	SFR-Basic
10 100985 RK	R-9,600	Residential 9,600 sq. ft.	SFR-Basic
10 102418 RK	R-9,600	Residential 9,600 sq. ft.	SFR-Basic
10 102419 RK	R-9,600	Residential 9,600 sq. ft.	SFR-Basic
10 103735 RK	R-9,600	Residential 9,600 sq. ft.	SFR-Basic
10 100986 RK	R-9,600	Residential 9,600 sq. ft.	SFR-Basic
10 103741 RK	R-9,600	Residential 9,600 sq. ft.	SFR-Basic
10 100060 RK	R-9,600	Residential 9,600 sq. ft.	SFR-Basic
10 102556 RK	R-9,600	Residential 9,600 sq. ft.	SFR-Basic
10 102557 RK	R-9,600	Residential 9,600 sq. ft.	SFR-Basic
10 102558 RK	R-9,600	Residential 9,600 sq. ft.	SFR-Basic
08 107613 000 01 RK	R-5	Rural-5 Acre	SFR-Basic
08 107614 RK	R-5	Rural-5 Acre	SFR-Basic
10 107626 RK	R-5	Rural-5 Acre	SFR-Basic
10 107628 RK	R-5	Rural-5 Acre	SFR-Basic
10 107629 RK	R-5	Rural-5 Acre	SFR-Basic
10 107630 RK	R-5	Rural-5 Acre	SFR-Basic
10 107631 RK	R-5	Rural-5 Acre	SFR-Basic
10 107130 RK	R-5	Rural-5 Acre	SFR-Basic
10 107131 RK	R-5	Rural-5 Acre	SFR-Basic
10 107786 RK	R-5	Rural-5 Acre	SFR-Basic
10 107132 RK	R-5	Rural-5 Acre	SFR-Basic
10 107129 000 01 RK	R-5	Rural-5 Acre	SFR-Basic
10 107785 RK	R-5	Rural-5 Acre	SFR-Basic
10 107627 RK	R-5	Rural-5 Acre	SFR-Basic
10 106421 RK	R-5	Rural-5 Acre	Single Family Residential
10 105260 RK	R-5	Rural-5 Acre	Single Family Residential
09 103302 000 01 RK	LDMR	Low Density Multiple Reside	Single Family Res-Combo
10 103643 RK	R-7,200	Residential 7,200 sq. ft.	SFR-Basic
10 102277 RK	R-7,200	Residential 7,200 sq. ft.	SFR-Basic
10 102278 RK	R-7,200	Residential 7,200 sq. ft.	SFR-Basic

Accessory Dwelling Units

Index # - File Name: 1.0022 - Single Family Dwellings Data\_Snohomish County.pdf

10 106308 RK	R-7,200	Residential 7,200 sq. ft.	SFR-Basic
10 100042 RK	R-7,200	Residential 7,200 sq. ft.	SFR-Basic
09 108684 RK	R-7,200	Residential 7,200 sq. ft.	SFR-Basic
10 107238 RK	R-7,200	Residential 7,200 sq. ft.	SFR-Basic
10 107965 RK	R-7,200	Residential 7,200 sq. ft.	SFR-Basic
10 105001 RK	R-7,200	Residential 7,200 sq. ft.	SFR-Basic
10 107964 RK	R-7,200	Residential 7,200 sq. ft.	SFR-Basic
10 107117 RK	R-7,200	Residential 7,200 sq. ft.	SFR-Basic
10 104537 RK	R-7,200	Residential 7,200 sq. ft.	SFR-Basic
10 100040 RK	R-7,200	Residential 7,200 sq. ft.	SFR-Basic
10 103644 RK	R-7,200	Residential 7,200 sq. ft.	SFR-Basic
10 105002 RK	R-7,200	Residential 7,200 sq. ft.	SFR-Basic
10 107966 RK	R-7,200	Residential 7,200 sq. ft.	SFR-Basic
10 108746 RK	R-7,200	Residential 7,200 sq. ft.	SFR-Basic
10 104536 RK	R-7,200	Residential 7,200 sq. ft.	SFR-Basic
10 104757 RK	R-7,200	Residential 7,200 sq. ft.	Single Family Residential
10 100287 RK	R-7,200	Residential 7,200 sq. ft.	Single Family Residential
10 100286 RK	R-7,200	Residential 7,200 sq. ft.	Single Family Residential
10 101180 RK	R-7,200	Residential 7,200 sq. ft.	Single Family Residential
10 101367 RK	R-5	Rural-5 Acre	Single Family Residential
10 103466 RK	R-5	Rural-5 Acre	Single Family Residential
09 107854 RK	R-5	Rural-5 Acre	Single Family Residential
08 108599 000 01 RK	LDMR	Low Density Multiple Reside	SFR-Basic
10 104770 RK	LDMR	Low Density Multiple Reside	SFR-Basic
10 102915 RK	LDMR	Low Density Multiple Reside	Single Family Residential
10 102733 RK	LDMR	Low Density Multiple Reside	Single Family Residential
10 104773 RK	LDMR	Low Density Multiple Reside	SFR-Basic
10 104772 RK	LDMR	Low Density Multiple Reside	SFR-Basic
10 108030 RK	LDMR	Low Density Multiple Reside	Single Family Residential
10 102736 RK	LDMR	Low Density Multiple Reside	Single Family Residential
10 102748 RK	LDMR	Low Density Multiple Reside	Single Family Residential
10 104771 RK	LDMR	Low Density Multiple Reside	SFR-Basic
10 102750 RK	LDMR	Low Density Multiple Reside	Single Family Residential
10 102744 RK	LDMR	Low Density Multiple Reside	Single Family Residential
10 106278 RK	LDMR	Low Density Multiple Reside	Single Family Residential
08 108305 000 01 RK	LDMR	Low Density Multiple Reside	SFR-Basic
10 104769 RK	LDMR	Low Density Multiple Reside	SFR-Basic
10 106868 RK	LDMR	Low Density Multiple Reside	Single Family Residential
10 106861 RK	R-7,200	Residential 7,200 sq. ft.	Single Family Residential
10 104716 RK	R-7,200	Residential 7,200 sq. ft.	Single Family Residential
10 103654 RK	R-7,200	Residential 7,200 sq. ft.	Single Family Residential
10 101641 RK	R-7,200	Residential 7,200 sq. ft.	SFR-Basic
09 108875 RK	R-7,200	Residential 7,200 sq. ft.	SFR-Basic
10 106862 RK	R-7,200	Residential 7,200 sq. ft.	Single Family Residential
10 104461 RK	R-7,200(PRD)	Residential 7,200 sq. ft.	SFR-Basic
10 104462 RK	R-7,200(PRD)	Residential 7,200 sq. ft.	SFR-Basic
10 108579 RK	R-7,200(PRD)	Residential 7,200 sq. ft.	SFR-Basic

Accessory Dwelling Units

Index # - File Name: 1.0022 - Single Family Dwellings Data\_Snohomish County.pdf

10 108580 RK	R-7,200(PRD)	Residential 7,200 sq. ft.	SFR-Basic
10 108581 RK	R-7,200(PRD)	Residential 7,200 sq. ft.	SFR-Basic
10 108582 RK	R-7,200(PRD)	Residential 7,200 sq. ft.	SFR-Basic
10 108583 RK	R-7,200(PRD)	Residential 7,200 sq. ft.	SFR-Basic
10 108584 RK	R-7,200(PRD)	Residential 7,200 sq. ft.	SFR-Basic
10 107305 RK	R-7,200(PRD)	Residential 7,200 sq. ft.	SFR-Basic
10 107306 RK	R-7,200(PRD)	Residential 7,200 sq. ft.	SFR-Basic
10 107307 RK	R-7,200(PRD)	Residential 7,200 sq. ft.	SFR-Basic
10 107308 RK	R-7,200(PRD)	Residential 7,200 sq. ft.	SFR-Basic
10 106493 RK	R-7,200(PRD)	Residential 7,200 sq. ft.	SFR-Basic
10 106494 RK	R-7,200(PRD)	Residential 7,200 sq. ft.	SFR-Basic
10 108585 RK	R-7,200(PRD)	Residential 7,200 sq. ft.	SFR-Basic
10 108586 RK	R-7,200(PRD)	Residential 7,200 sq. ft.	SFR-Basic
10 108587 RK	R-7,200(PRD)	Residential 7,200 sq. ft.	SFR-Basic
10 107309 RK	R-7,200(PRD)	Residential 7,200 sq. ft.	SFR-Basic
10 107310 RK	R-7,200(PRD)	Residential 7,200 sq. ft.	SFR-Basic
10 108588 RK	R-7,200(PRD)	Residential 7,200 sq. ft.	SFR-Basic
10 108589 RK	R-7,200(PRD)	Residential 7,200 sq. ft.	SFR-Basic
10 108590 RK	R-7,200(PRD)	Residential 7,200 sq. ft.	SFR-Basic
09 108513 RK	R-7,200	Residential 7,200 sq. ft.	Single Family Residential
10 103826 RK	R-7,200(PRD)	Residential 7,200 sq. ft.	SFR-Basic
10 103827 RK	R-7,200(PRD)	Residential 7,200 sq. ft.	SFR-Basic
10 102393 RK	R-7,200	Residential 7,200 sq. ft.	SFR-Basic
10 105797 RK	R-7,200	Residential 7,200 sq. ft.	Single Family Residential
10 108021 RK	R-7,200	Residential 7,200 sq. ft.	Single Family Residential
10 105940 RK	R-7,200	Residential 7,200 sq. ft.	Single Family Residential
10 103828 RK	R-7,200(PRD)	Residential 7,200 sq. ft.	SFR-Basic
10 103829 RK	R-7,200(PRD)	Residential 7,200 sq. ft.	SFR-Basic
10 103830 RK	R-7,200(PRD)	Residential 7,200 sq. ft.	SFR-Basic
10 103831 RK	R-7,200(PRD)	Residential 7,200 sq. ft.	SFR-Basic
10 103832 RK	R-7,200(PRD)	Residential 7,200 sq. ft.	SFR-Basic
10 103833 RK	R-7,200(PRD)	Residential 7,200 sq. ft.	SFR-Basic
10 104456 RK	R-7,200(PRD)	Residential 7,200 sq. ft.	SFR-Basic
10 104457 RK	R-7,200(PRD)	Residential 7,200 sq. ft.	SFR-Basic
10 106483 RK	R-7,200(PRD)	Residential 7,200 sq. ft.	SFR-Basic
10 106484 RK	R-7,200(PRD)	Residential 7,200 sq. ft.	SFR-Basic
10 106485 RK	R-7,200(PRD)	Residential 7,200 sq. ft.	SFR-Basic
10 106486 RK	R-7,200(PRD)	Residential 7,200 sq. ft.	SFR-Basic
10 106487 RK	R-7,200(PRD)	Residential 7,200 sq. ft.	SFR-Basic
10 106488 RK	R-7,200(PRD)	Residential 7,200 sq. ft.	SFR-Basic
10 106489 RK	R-7,200(PRD)	Residential 7,200 sq. ft.	SFR-Basic
10 106490 RK	R-7,200(PRD)	Residential 7,200 sq. ft.	SFR-Basic
10 106491 RK	R-7,200(PRD)	Residential 7,200 sq. ft.	SFR-Basic
10 104458 RK	R-7,200(PRD)	Residential 7,200 sq. ft.	SFR-Basic
10 104459 RK	R-7,200(PRD)	Residential 7,200 sq. ft.	SFR-Basic
10 104460 RK	R-7,200(PRD)	Residential 7,200 sq. ft.	SFR-Basic
10 103437 RK	R-7,200(PRD)	Residential 7,200 sq. ft.	SFR-Basic

Accessory Dwelling Units

Index # - File Name: 1.0022 - Single Family Dwellings Data\_Snohomish County.pdf

10 104504 RK	R-7,200(PRD)	Residential 7,200 sq. ft.	SFR-Basic
10 104506 RK	R-7,200(PRD)	Residential 7,200 sq. ft.	SFR-Basic
10 107347 RK	R-7,200(PRD)	Residential 7,200 sq. ft.	SFR-Basic
10 104507 RK	R-7,200(PRD)	Residential 7,200 sq. ft.	SFR-Basic
10 101002 RK	R-7,200(PRD)	Residential 7,200 sq. ft.	SFR-Basic
10 104502 RK	R-7,200(PRD)	Residential 7,200 sq. ft.	SFR-Basic
10 103441 RK	R-7,200(PRD)	Residential 7,200 sq. ft.	SFR-Basic
10 102441 RK	R-7,200(PRD)	Residential 7,200 sq. ft.	SFR-Basic
10 102444 RK	R-7,200(PRD)	Residential 7,200 sq. ft.	SFR-Basic
10 100095 RK	R-7,200(PRD)	Residential 7,200 sq. ft.	SFR-Basic
10 100622 RK	R-5	Rural-5 Acre	Single Family Residential
10 104501 RK	R-7,200(PRD)	Residential 7,200 sq. ft.	SFR-Basic
10 100690 RK	R-7,200(PRD)	Residential 7,200 sq. ft.	SFR-Basic
10 101157 RK	R-7,200(PRD)	Residential 7,200 sq. ft.	SFR-Basic
10 100692 RK	R-7,200(PRD)	Residential 7,200 sq. ft.	SFR-Basic
10 104500 RK	R-7,200(PRD)	Residential 7,200 sq. ft.	SFR-Basic
10 100687 RK	R-7,200(PRD)	Residential 7,200 sq. ft.	SFR-Basic
10 102074 RK	R-7,200	Residential 7,200 sq. ft.	Single Family Residential
10 102075 RK	R-7,200	Residential 7,200 sq. ft.	Single Family Residential
10 102076 RK	R-7,200	Residential 7,200 sq. ft.	Single Family Residential
10 103030 RK	R-9,600	Residential 9,600 sq. ft.	SFR-Basic
10 100184 RK	CITY	City	SFR-Basic
10 101184 RK	CITY	City	SFR-Basic
09 109278 RK	CITY	City	SFR-Basic
09 109279 RK	CITY	City	SFR-Basic
09 109280 RK	CITY	City	SFR-Basic
09 109281 RK	CITY	City	SFR-Basic
09 109282 RK	CITY	City	SFR-Basic
09 109283 RK	CITY	City	SFR-Basic
09 109267 RK	CITY	City	SFR-Basic
09 109268 RK	CITY	City	SFR-Basic
09 109269 RK	CITY	City	SFR-Basic
09 109270 RK	CITY	City	SFR-Basic
09 109271 RK	CITY	City	SFR-Basic
09 109272 RK	CITY	City	SFR-Basic
09 109273 RK	CITY	City	SFR-Basic
09 109274 RK	CITY	City	SFR-Basic
09 109275 RK	CITY	City	SFR-Basic
09 109276 RK	CITY	City	SFR-Basic
09 109277 RK	CITY	City	SFR-Basic
10 106137 RK	CITY	City	Single Family Residential
10 106134 RK	CITY	City	Single Family Residential
10 101430 RK	CITY	City	SFR-Basic
10 103435 RK	CITY	City	SFR-Basic
10 104888 RK	CITY	City	SFR-Basic
10 104890 RK	CITY	City	SFR-Basic
10 100157 RK	MR	Multiple Residential	Single Family Residential

Accessory Dwelling Units

Index # - File Name: 1.0022 - Single Family Dwellings Data\_Snohomish County.pdf

09 108057 RK	R-7,200(PRD)	Residential 7,200 sq. ft.	SFR-Basic
09 108059 RK	R-7,200(PRD)	Residential 7,200 sq. ft.	SFR-Basic
10 100859 RK	R-7,200(PRD)	Residential 7,200 sq. ft.	SFR-Basic
10 100866 RK	R-7,200(PRD)	Residential 7,200 sq. ft.	SFR-Basic
10 100990 RK	R-7,200(PRD)	Residential 7,200 sq. ft.	SFR-Basic
10 100993 RK	R-7,200(PRD)	Residential 7,200 sq. ft.	SFR-Basic
10 104306 RK	R-7,200	Residential 7,200 sq. ft.	SFR-Basic
10 102257 RK	R-7,200	Residential 7,200 sq. ft.	SFR-Basic
10 102256 RK	R-7,200	Residential 7,200 sq. ft.	SFR-Basic
10 102258 RK	R-7,200	Residential 7,200 sq. ft.	SFR-Basic
10 104312 RK	R-7,200	Residential 7,200 sq. ft.	SFR-Basic
10 103690 RK	R-7,200	Residential 7,200 sq. ft.	Single Family Residential
10 103691 RK	R-7,200	Residential 7,200 sq. ft.	Single Family Residential
10 104305 RK	R-7,200	Residential 7,200 sq. ft.	SFR-Basic
10 108826 RK	R-5	Rural-5 Acre	SFR-Basic
10 108841 RK	R-5	Rural-5 Acre	SFR-Basic
10 108245 RK	R-5	Rural-5 Acre	SFR-Basic
10 104036 RK	R-7,200	Residential 7,200 sq. ft.	SFR-Basic
10 103512 RK	R-7,200	Residential 7,200 sq. ft.	SFR-Basic
10 102598 RK	R-7,200	Residential 7,200 sq. ft.	SFR-Basic
10 101881 RK	R-7,200	Residential 7,200 sq. ft.	SFR-Basic
10 101645 RK	R-7,200	Residential 7,200 sq. ft.	SFR-Basic
10 101652 RK	R-7,200	Residential 7,200 sq. ft.	SFR-Basic
10 101647 RK	R-7,200	Residential 7,200 sq. ft.	SFR-Basic
10 101648 RK	R-7,200	Residential 7,200 sq. ft.	SFR-Basic
10 101882 RK	R-7,200	Residential 7,200 sq. ft.	SFR-Basic
10 108827 RK	R-5	Rural-5 Acre	SFR-Basic
10 102797 RK	R-7,200	Residential 7,200 sq. ft.	Single Family Residential
10 100407 RK	R-7,200	Residential 7,200 sq. ft.	SFR-Basic
10 107077 RK	R-7,200	Residential 7,200 sq. ft.	SFR-Basic
10 107078 RK	R-7,200	Residential 7,200 sq. ft.	SFR-Basic
10 107076 RK	R-7,200	Residential 7,200 sq. ft.	SFR-Basic
10 107525 RK	R-7,200	Residential 7,200 sq. ft.	SFR-Basic
10 107079 RK	R-7,200	Residential 7,200 sq. ft.	SFR-Basic
10 107080 RK	R-7,200	Residential 7,200 sq. ft.	SFR-Basic
10 101651 RK	R-7,200	Residential 7,200 sq. ft.	SFR-Basic
10 101646 RK	R-7,200	Residential 7,200 sq. ft.	SFR-Basic
10 101649 RK	R-7,200	Residential 7,200 sq. ft.	SFR-Basic
10 101650 RK	R-7,200	Residential 7,200 sq. ft.	SFR-Basic
10 107522 RK	R-7,200	Residential 7,200 sq. ft.	SFR-Basic
10 107523 RK	R-7,200	Residential 7,200 sq. ft.	SFR-Basic
10 107524 RK	R-7,200	Residential 7,200 sq. ft.	SFR-Basic
10 109109 RK	R-7,200	Residential 7,200 sq. ft.	SFR-Basic
10 109110 RK	R-7,200	Residential 7,200 sq. ft.	SFR-Basic
10 102204 MH	R-5	Rural-5 Acre	Double Wide
09 108898 RK	CITY	City	Single Family Residential
09 108900 RK	CITY	City	Single Family Residential

Accessory Dwelling Units

Index # - File Name: 1.0022 - Single Family Dwellings Data\_Snohomish County.pdf

09 108901 RK	CITY	City	Single Family Residential
09 108127 RK	MR	Multiple Residential	SFR-Basic
09 108124 RK	MR	Multiple Residential	SFR-Basic
10 103903 RK	R-7,200	Residential 7,200 sq. ft.	Single Family Residential
10 107123 RK	R-5	Rural-5 Acre	SFR-Basic
10 107122 RK	R-5	Rural-5 Acre	SFR-Basic
10 107312 RK	R-7,200(PRD)	Residential 7,200 sq. ft.	SFR-Basic
10 107313 RK	R-7,200(PRD)	Residential 7,200 sq. ft.	SFR-Basic
10 107314 RK	R-7,200(PRD)	Residential 7,200 sq. ft.	SFR-Basic
10 107315 RK	R-7,200(PRD)	Residential 7,200 sq. ft.	SFR-Basic
10 108205 RK	R-7,200(PRD)	Residential 7,200 sq. ft.	SFR-Basic
10 108206 RK	R-7,200(PRD)	Residential 7,200 sq. ft.	SFR-Basic
10 108207 RK	R-7,200(PRD)	Residential 7,200 sq. ft.	SFR-Basic
10 108208 RK	R-7,200(PRD)	Residential 7,200 sq. ft.	SFR-Basic
10 107140 RK	R-7,200(PRD)	Residential 7,200 sq. ft.	SFR-Basic
10 107141 RK	R-7,200(PRD)	Residential 7,200 sq. ft.	SFR-Basic
10 108209 RK	R-7,200(PRD)	Residential 7,200 sq. ft.	SFR-Basic
10 108210 RK	R-7,200(PRD)	Residential 7,200 sq. ft.	SFR-Basic
10 104246 RK	A-10	Agriculture-10 Acre	Single Family Residential
10 100652 RK	R-7,200	Residential 7,200 sq. ft.	SFR-Basic
10 103717 RK	R-7,200	Residential 7,200 sq. ft.	SFR-Basic
10 101185 RK	R-7,200	Residential 7,200 sq. ft.	SFR-Basic
10 108993 RK	R-7,200	Residential 7,200 sq. ft.	Single Family Residential
10 101642 RK	R-7,200	Residential 7,200 sq. ft.	SFR-Basic
10 102969 RK	R-7,200	Residential 7,200 sq. ft.	SFR-Basic
10 100651 RK	R-7,200	Residential 7,200 sq. ft.	SFR-Basic
10 107006 RK	R-7,200	Residential 7,200 sq. ft.	Single Family Residential
10 103529 RK	R-7,200	Residential 7,200 sq. ft.	SFR-Basic
10 109196 RK	R-7,200	Residential 7,200 sq. ft.	Single Family Residential
10 102017 RK	R-7,200	Residential 7,200 sq. ft.	SFR-Basic
10 101640 RK	R-7,200	Residential 7,200 sq. ft.	SFR-Basic
09 108876 RK	R-7,200	Residential 7,200 sq. ft.	SFR-Basic
10 100185 RK	R-7,200	Residential 7,200 sq. ft.	SFR-Basic
10 105941 RK	R-7,200	Residential 7,200 sq. ft.	Single Family Residential
10 104101 RK	R-7,200	Residential 7,200 sq. ft.	Single Family Residential
10 101639 RK	R-7,200	Residential 7,200 sq. ft.	SFR-Basic
10 104102 RK	R-7,200	Residential 7,200 sq. ft.	Single Family Residential
09 108619 RK	LDMR	Low Density Multiple Reside	SFR-Basic
09 108620 RK	LDMR	Low Density Multiple Reside	SFR-Basic
09 108621 RK	LDMR	Low Density Multiple Reside	SFR-Basic
09 108622 RK	LDMR	Low Density Multiple Reside	SFR-Basic
09 108623 RK	LDMR	Low Density Multiple Reside	SFR-Basic
10 103646 RK	R-5	Rural-5 Acre	Single Family Residential
10 103647 RK	R-5	Rural-5 Acre	Single Family Residential
09 106761 RK	R-5	Rural-5 Acre	Single Family Residential
10 103648 RK	R-5	Rural-5 Acre	Single Family Residential
08 104178 000 01 RK	R-5	Rural-5 Acre	Single Family Res-Combo

Accessory Dwelling Units

Index # - File Name: 1.0022 - Single Family Dwellings Data\_Snohomish County.pdf

10 100321 RK	R-5	Rural-5 Acre	SFR-Basic
10 101897 RK	R-5	Rural-5 Acre	Single Family Residential
09 103843 MH	R-5	Rural-5 Acre	Triple Wide
09 108097 RK	CITY	City	Single Family Residential
09 108098 RK	CITY	City	Single Family Residential
09 108099 RK	CITY	City	Single Family Residential
09 108296 RK	MR	Multiple Residential	SFR-Basic
09 108297 RK	MR	Multiple Residential	SFR-Basic
09 107788 RK	MR	Multiple Residential	SFR-Basic
09 107789 RK	MR	Multiple Residential	SFR-Basic
10 100061 RK	R-7,200	Residential 7,200 sq. ft.	SFR-Basic
10 100062 RK	R-7,200	Residential 7,200 sq. ft.	SFR-Basic
10 100063 RK	R-7,200	Residential 7,200 sq. ft.	SFR-Basic
10 100064 RK	R-7,200	Residential 7,200 sq. ft.	SFR-Basic
10 100065 RK	R-7,200	Residential 7,200 sq. ft.	SFR-Basic
10 100066 RK	R-7,200	Residential 7,200 sq. ft.	SFR-Basic
10 100067 RK	R-7,200	Residential 7,200 sq. ft.	SFR-Basic
10 100068 RK	R-7,200	Residential 7,200 sq. ft.	SFR-Basic
10 100069 RK	R-7,200	Residential 7,200 sq. ft.	SFR-Basic
10 101386 RK	R-7,200	Residential 7,200 sq. ft.	SFR-Basic
10 100763 RK	R-7,200	Residential 7,200 sq. ft.	SFR-Basic
10 100764 RK	R-7,200	Residential 7,200 sq. ft.	SFR-Basic
10 100766 RK	R-7,200	Residential 7,200 sq. ft.	SFR-Basic
10 100070 RK	R-7,200	Residential 7,200 sq. ft.	SFR-Basic
10 108244 RK	R-5	Rural-5 Acre	SFR-Basic
10 108505 RK	R-5	Rural-5 Acre	SFR-Basic
10 104290 RK	RRT-10	Rural Resource Transition-10	Single Family Residential
10 106087 RK	RD	Rural Diversification	Accessory Apt Detached
10 107121 RK	R-5	Rural-5 Acre	SFR-Basic
10 101142 RK	R-5	Rural-5 Acre	Single Family Residential
09 106572 RK	R-5	Rural-5 Acre	Single Family Residential
10 105087 000 01 RK	R-5	Rural-5 Acre	Single Family Residential
07 103428 000 01 RK	R-5	Rural-5 Acre	Single Family Res-Combo
10 102994 RK	R-5	Rural-5 Acre	Single Family Residential
08 108000 000 01 RK	F	Forestry	Single Family Res-Combo
09 100332 RK	F	Forestry	Single Family Res-Combo
10 100801 RK	A-10	Agriculture-10 Acre	Single Family Residential
10 105672 RK	R-5	Rural-5 Acre	Accessory Apt Detached
10 103883 RK	R-5	Rural-5 Acre	Single Family Residential
10 101019 RK	R-9,600	Residential 9,600 sq. ft.	Single Family Residential
08 106985 000 01 RK	R-5	Rural-5 Acre	Accessory Apt Detached-Combo
08 109218 000 01 RK	R-5	Rural-5 Acre	Accessory Apt Detached-Combo
09 102946 000 01 RK	R-5	Rural-5 Acre	Single Family Res-Combo
09 101643 000 01 RK	R-5	Rural-5 Acre	Single Family Res-Combo
10 103408 RK	R-5	Rural-5 Acre	Single Family Residential
10 102208 RK	F	Forestry	Single Family Residential
09 108916 RK	WFB	Waterfront Beach	Single Family Residential



Accessory Dwelling Units

Index # - File Name: 1.0022 - Single Family Dwellings Data\_Snohomish County.pdf

10 105782 RK	WFB	Waterfront Beach	Single Family Residential
10 105517 MH	R-5	Rural-5 Acre	Double Wide
10 101105 000 01 RK	R-5	Rural-5 Acre	Single Family Residential
10 101008 RK	R-5	Rural-5 Acre	Single Family Residential
10 107188 RK	R-5	Rural-5 Acre	Single Family Residential
09 108496 MH	PRD-20,000(M	Residential 20,000 sq. ft.	Triple Wide
10 105801 RK	F	Forestry	Single Family Residential
10 105659 RK	R-5	Rural-5 Acre	Single Family Residential
09 108837 RK	R-5	Rural-5 Acre	Single Family Residential
10 100289 000 01 RK	F	Forestry	Single Family Residential
08 107504 000 01 RK	F	Forestry	Single Family Res-Combo
10 104364 RK	R-12,500	Residential 12,500 sq. ft.	Single Family Residential
08 105540 000 01 RK	WFB	Waterfront Beach	Single Family Res-Combo
10 100118 RK	R-8,400	Residential 8,400 sq. ft.	SFR-Basic
10 105279 RK	R-8,400	Residential 8,400 sq. ft.	Accessory Apt Detached
10 103492 RK	R-5	Rural-5 Acre	Single Family Residential
09 107494 RK	R-5	Rural-5 Acre	Accessory Apt Detached
10 105355 RK	R-5	Rural-5 Acre	Single Family Residential
10 101156 RK	R-5	Rural-5 Acre	Single Family Residential
08 102414 000 01 RK	R-5	Rural-5 Acre	Single Family Res-Combo
10 106654 RK	R-5	Rural-5 Acre	Single Family Residential
08 106617 000 01 RK	R-5	Rural-5 Acre	Single Family Res-Combo
10 101905 RK	R-5	Rural-5 Acre	Single Family Residential
08 102660 000 01 RK	R-5	Rural-5 Acre	Accessory Apt Detached-Combo
06 129220 000 01 RK	F	Forestry	Single Family Res-Combo
10 103045 RK	WFB	Waterfront Beach	Single Family Residential
10 104287 RK	R-5	Rural-5 Acre	Single Family Residential
10 104834 RK	WFB	Waterfront Beach	Single Family Residential
08 105225 RK	WFB	Waterfront Beach	Single Family Res-Combo
09 108581 RK	R-8,400	Residential 8,400 sq. ft.	Duplex-Basic
10 108032 RK	R-7,200	Residential 7,200 sq. ft.	Single Family Residential
10 104694 RK	A-10	Agriculture-10 Acre	Single Family Residential
10 104867 000 01 RK	RRT-10	Rural Resource Transition-10	Single Family Residential
09 102861 RK	R-5	Rural-5 Acre	Single Family Res-Combo
10 103455 MH	RRT-10	Rural Resource Transition-10	Double Wide
09 108029 RK	CITY	City	Accessory Apt Detached
10 101148 RK	R-5	Rural-5 Acre	Single Family Residential
10 106109 RK	R-5	Rural-5 Acre	Single Family Residential
10 102757 RK	R-5	Rural-5 Acre	Single Family Residential
10 104723 RK	R-5	Rural-5 Acre	Single Family Residential
05 129031 000 01 RK	R-5	Rural-5 Acre	Single Family Res-Combo
10 103710 RK	R-5	Rural-5 Acre	Single Family Residential
10 102588 RK	R-5	Rural-5 Acre	Single Family Residential
10 104059 MH	R-5	Rural-5 Acre	Double Wide
10 106060 RK	R-5	Rural-5 Acre	Accessory Apt Detached
10 108328 RK	R-5	Rural-5 Acre	Single Family Residential
08 109181 000 01 RK	R-5	Rural-5 Acre	Single Family Res-Combo

Accessory Dwelling Units

Index # - File Name: 1.0022 - Single Family Dwellings Data\_Snohomish County.pdf

09 108624 RK	R-5	Rural-5 Acre	Single Family Residential
09 108941 RK	R-5	Rural-5 Acre	Single Family Residential
10 101787 RK	R-5	Rural-5 Acre	Single Family Residential
10 103252 RK	RD	Rural Diversification	Single Family Residential
08 105426 000 01 RK	RD	Rural Diversification	Accessory Apt Detached-Combo
10 101170 RK	R-5	Rural-5 Acre	Single Family Residential
10 103606 RK	R-5	Rural-5 Acre	Single Family Residential
09 102016 000 01 RK	R-9,600	Residential 9,600 sq. ft.	Single Family Res-Combo
08 108963 000 01 RK	RRT-10	Rural Resource Transition-10	Accessory Apt Detached-Combo
09 103573 RK	MR	Multiple Residential	Single Family Res-Combo
10 101681 MH	R-5	Rural-5 Acre	Double Wide
10 102109 RK	R-5	Rural-5 Acre	Accessory Apt Detached
10 101191 RK	R-5	Rural-5 Acre	Single Family Residential
10 101017 RK	R-5	Rural-5 Acre	Single Family Residential
10 100430 RK	R-5	Rural-5 Acre	Single Family Residential
09 108018 RK	R-5	Rural-5 Acre	Single Family Residential
06 132186 000 01 RK	R-5	Rural-5 Acre	Single Family Res-Combo
08 108389 000 01 RK	R-5	Rural-5 Acre	Single Family Res-Combo
10 106058 RK	R-5	Rural-5 Acre	Single Family Residential
08 109912 RK	RD	Rural Diversification	Single Family Res-Combo
10 106667 MH	R-5	Rural-5 Acre	Double Wide
09 103684 RK	R-9,600	Residential 9,600 sq. ft.	Single Family Residential
10 104540 RK	R-5	Rural-5 Acre	Single Family Residential
09 109102 MH	R-5	Rural-5 Acre	Double Wide
11 100231 RK	R-5	Rural-5 Acre	SFR-Basic
11 103674 MH	R-5	Rural-5 Acre	Triple Wide
11 106713 RK	R-5	Rural-5 Acre	Single Family Residential
11 103479 RK	R-5	Rural-5 Acre	Accessory Apt Detached
10 109541 RK	F	Forestry	Single Family Residential
10 104289 RK	R-5	Rural-5 Acre	Single Family Residential
10 109282 MH	RRT-10	Rural Resource Transition-10	Double Wide
11 104703 RK	R-5	Rural-5 Acre	Single Family Residential
09 108535 000 01 MH	RD	Rural Diversification	Double Wide
09 107768 000 01 RK	R-5	Rural-5 Acre	Single Family Residential
11 100337 RK	R-5	Rural-5 Acre	Single Family Residential
11 100919 RK	R-5	Rural-5 Acre	Single Family Residential
09 103779 000 01 RK	R-5	Rural-5 Acre	Single Family Residential
10 107277 RK	R-5	Rural-5 Acre	Single Family Residential
11 104035 RK	RD	Rural Diversification	Single Family Residential
11 104353 RK	RD	Rural Diversification	Single Family Residential
11 103784 RK	R-5	Rural-5 Acre	Single Family Residential
09 105056 000 01 RK	R-5	Rural-5 Acre	Single Family Residential
11 106671 MH	R-5	Rural-5 Acre	Triple Wide
11 102380 RK	R-5	Rural-5 Acre	Single Family Residential
11 106876 RK	R-5	Rural-5 Acre	Single Family Residential
11 105366 RK	R-5	Rural-5 Acre	Single Family Residential
11 102311 RK	R-5	Rural-5 Acre	Accessory Apt Detached

Accessory Dwelling Units

Index # - File Name: 1.0022 - Single Family Dwellings Data\_Snohomish County.pdf

11 105232 RK	R-5	Rural-5 Acre	Single Family Residential
11 109327 RK	R-5	Rural-5 Acre	Single Family Residential
10 105796 RK	R-5	Rural-5 Acre	Single Family Residential
10 104267 RK	R-5	Rural-5 Acre	Single Family Residential
11 102554 MH	R-5	Rural-5 Acre	Double Wide
10 107282 000 01 RK	R-5	Rural-5 Acre	Single Family Residential
11 101623 RK	R-7,200	Residential 7,200 sq. ft.	Single Family Residential
11 105116 RK	RRT-10	Rural Resource Transition-10	Single Family Residential
11 104783 RK	RRT-10	Rural Resource Transition-10	Single Family Residential
11 101824 RK	R-7,200	Residential 7,200 sq. ft.	Single Family Residential
11 108180 RK	R-9,600	Residential 9,600 sq. ft.	SFR-Basic
11 103434 RK	MR	Multiple Residential	Accessory Apt Detached
11 107323 000 01 RK	WFB	Waterfront Beach	Single Family Residential
11 104915 RK	MR	Multiple Residential	Duplex
09 101929 000 01 RK	R-5	Rural-5 Acre	Single Family Res-Combo
11 102527 RK	R-5	Rural-5 Acre	Single Family Residential
11 103828 RK	R-7,200	Residential 7,200 sq. ft.	SFR-Basic
11 103831 RK	R-7,200	Residential 7,200 sq. ft.	SFR-Basic
09 102452 000 01 RK	R-5	Rural-5 Acre	Single Family Res-Combo
11 106391 RK	F	Forestry	Single Family Residential
11 100224 RK	R-5	Rural-5 Acre	SFR-Basic
11 108461 RK	F	Forestry	Single Family Residential
11 103511 000 01 RK	R-5	Rural-5 Acre	Single Family Residential
10 107185 RK	MR	Multiple Residential	SFR-Basic
11 104958 RK	MR	Multiple Residential	Single Family Residential
11 100487 RK	R-8,400	Residential 8,400 sq. ft.	Single Family Residential
11 107080 RK	R-12,500	Residential 12,500 sq. ft.	Single Family Residential
10 108999 RK	R-8,400	Residential 8,400 sq. ft.	Single Family Residential
11 100691 RK	LDMR	Low Density Multiple Reside	Duplex-Basic
11 104173 RK	R-8,400	Residential 8,400 sq. ft.	Single Family Residential
10 109312 RK	R-8,400	Residential 8,400 sq. ft.	Single Family Residential
10 100595 000 01 RK	R-5	Rural-5 Acre	Single Family Residential
11 106770 MH	R-5	Rural-5 Acre	Single Wide
11 105940 RK	R-5	Rural-5 Acre	Single Family Residential
11 103188 MH	PRD-20,000(M	Residential 20,000 sq. ft.	Double Wide
11 101466 RK	R-5	Rural-5 Acre	Single Family Residential
11 105703 RK	R-5	Rural-5 Acre	Single Family Residential
10 106471 RK	R-5	Rural-5 Acre	Single Family Residential
10 106474 000 01 RK	R-5	Rural-5 Acre	Accessory Apt Detached
11 106521 RK	R-9,600	Residential 9,600 sq. ft.	Accessory Apt Detached
11 103774 RK	R-8,400	Residential 8,400 sq. ft.	Single Family Residential
10 109053 RK	R-8,400	Residential 8,400 sq. ft.	Duplex-Basic
11 107583 RK	R-9,600	Residential 9,600 sq. ft.	Single Family Residential
11 103050 RK	LDMR	Low Density Multiple Reside	Single Family Residential
10 109539 RK	R-9,600	Residential 9,600 sq. ft.	Single Family Residential
10 107284 MH	R-5	Rural-5 Acre	Double Wide
10 105473 MH	R-5	Rural-5 Acre	Double Wide

Accessory Dwelling Units

Index # - File Name: 1.0022 - Single Family Dwellings Data\_Snohomish County.pdf

10 108603 RK	R-5	Rural-5 Acre	Single Family Residential
11 107144 MH	F	Forestry	Double Wide
09 109115 RK	CITY	City	Single Family Residential
09 109116 RK	CITY	City	Single Family Residential
10 108954 MH	R-5	Rural-5 Acre	Double Wide
11 104363 RK	R-5	Rural-5 Acre	Single Family Residential
11 107102 RK	R-5	Rural-5 Acre	Single Family Residential
11 108878 000 01 RK	R-5	Rural-5 Acre	Single Family Residential
11 107424 RK	R-5	Rural-5 Acre	Single Family Residential
11 108418 MH	R-5	Rural-5 Acre	Single Wide
11 105181 RK	R-7,200	Residential 7,200 sq. ft.	Accessory Apt Detached
11 101040 RK	R-5	Rural-5 Acre	Single Family Residential
11 101581 MH	R-5	Rural-5 Acre	Double Wide
11 103460 RK	R-5	Rural-5 Acre	Single Family Residential
10 103810 000 01 RK	RD	Rural Diversification	Single Family Residential
11 100654 RK	R-5	Rural-5 Acre	Accessory Apt Detached
11 101644 MH	RD	Rural Diversification	Triple Wide
10 108283 000 01 RK	R-5	Rural-5 Acre	Single Family Residential
09 108298 000 01 RK	MR	Multiple Residential	SFR-Basic
11 101620 RK	R-5	Rural-5 Acre	SFR-Basic
11 101358 RK	R-5	Rural-5 Acre	Single Family Residential
11 100702 MH	R-5	Rural-5 Acre	Double Wide
09 106990 000 01 RK	R-5	Rural-5 Acre	Single Family Residential
11 105584 MH	R-5	Rural-5 Acre	Double Wide
11 103780 RK			Single Family Residential
11 101174 RK	R-5	Rural-5 Acre	Single Family Residential
11 101176 RK	R-5	Rural-5 Acre	Single Family Residential
11 101178 RK	R-5	Rural-5 Acre	Single Family Residential
11 105752 RK	R-5	Rural-5 Acre	Single Family Residential
10 105153 MH	F	Forestry	Single Wide
11 106368 RK	MR	Multiple Residential	Single Family Residential
11 105896 RK	R-7,200	Residential 7,200 sq. ft.	SFR-Basic
11 105889 RK	R-7,200	Residential 7,200 sq. ft.	SFR-Basic
11 105890 RK	R-7,200	Residential 7,200 sq. ft.	SFR-Basic
11 105898 RK	R-7,200	Residential 7,200 sq. ft.	SFR-Basic
11 105899 RK	R-7,200	Residential 7,200 sq. ft.	SFR-Basic
11 105900 RK	R-7,200	Residential 7,200 sq. ft.	SFR-Basic
11 107026 RK	R-7,200	Residential 7,200 sq. ft.	Single Family Residential
11 105888 RK	R-7,200	Residential 7,200 sq. ft.	SFR-Basic
11 105894 RK	R-7,200	Residential 7,200 sq. ft.	SFR-Basic
11 105887 RK	R-7,200	Residential 7,200 sq. ft.	SFR-Basic
11 105893 RK	R-7,200	Residential 7,200 sq. ft.	SFR-Basic
11 105886 RK	R-7,200	Residential 7,200 sq. ft.	SFR-Basic
11 105571 RK	R-5	Rural-5 Acre	SFR-Basic
11 102055 RK	R-5	Rural-5 Acre	Single Family Residential
11 100347 RK	R-7,200	Residential 7,200 sq. ft.	Single Family Residential
11 107458 RK	R-9,600	Residential 9,600 sq. ft.	Single Family Residential

Accessory Dwelling Units

Index # - File Name: 1.0022 - Single Family Dwellings Data\_Snohomish County.pdf

11 103732 RK	R-5	Rural-5 Acre	SFR-Basic
10 108622 RK	R-5	Rural-5 Acre	Single Family Residential
11 103730 RK	R-5	Rural-5 Acre	SFR-Basic
11 102289 RK	R-7,200	Residential 7,200 sq. ft.	Single Family Residential
11 104081 RK	R-7,200	Residential 7,200 sq. ft.	Single Family Residential
10 109479 RK	R-7,200	Residential 7,200 sq. ft.	Single Family Residential
11 103104 RK	R-7,200	Residential 7,200 sq. ft.	Single Family Residential
11 108079 RK	R-7,200	Residential 7,200 sq. ft.	Single Family Residential
11 101571 RK	R-7,200	Residential 7,200 sq. ft.	Single Family Residential
11 102635 RK	R-7,200	Residential 7,200 sq. ft.	SFR-Basic
10 108632 RK	R-5	Rural-5 Acre	Single Family Residential
10 109467 RK	R-7,200(PRD)	Residential 7,200 sq. ft.	SFR-Basic
10 109468 RK	R-7,200(PRD)	Residential 7,200 sq. ft.	SFR-Basic
10 109469 RK	R-7,200(PRD)	Residential 7,200 sq. ft.	SFR-Basic
10 109470 RK	R-7,200(PRD)	Residential 7,200 sq. ft.	SFR-Basic
10 109471 RK	R-7,200(PRD)	Residential 7,200 sq. ft.	SFR-Basic
10 109472 RK	R-7,200(PRD)	Residential 7,200 sq. ft.	SFR-Basic
10 109473 RK	R-7,200(PRD)	Residential 7,200 sq. ft.	SFR-Basic
10 109466 RK	R-7,200(PRD)	Residential 7,200 sq. ft.	SFR-Basic
10 109465 RK	R-7,200(PRD)	Residential 7,200 sq. ft.	SFR-Basic
10 109439 RK	R-7,200(PRD)	Residential 7,200 sq. ft.	SFR-Basic
10 109440 RK	R-7,200(PRD)	Residential 7,200 sq. ft.	SFR-Basic
10 109441 RK	R-7,200(PRD)	Residential 7,200 sq. ft.	SFR-Basic
10 109442 RK	R-7,200(PRD)	Residential 7,200 sq. ft.	SFR-Basic
10 109443 RK	R-7,200(PRD)	Residential 7,200 sq. ft.	SFR-Basic
10 109444 RK	R-7,200(PRD)	Residential 7,200 sq. ft.	SFR-Basic
11 104594 RK	F	Forestry	Single Family Residential
11 100788 RK	R-5	Rural-5 Acre	Single Family Residential
11 100786 RK	R-5	Rural-5 Acre	Single Family Residential
11 101023 RK	R-5	Rural-5 Acre	Single Family Residential
11 105570 RK	R-5	Rural-5 Acre	SFR-Basic
11 106016 RK	MR	Multiple Residential	Single Family Residential
11 102047 RK	MR	Multiple Residential	Single Family Residential
11 100386 RK	R-5	Rural-5 Acre	Single Family Residential
11 105569 RK	R-5	Rural-5 Acre	SFR-Basic
10 109111 RK	R-7,200	Residential 7,200 sq. ft.	SFR-Basic
10 109112 RK	R-7,200	Residential 7,200 sq. ft.	SFR-Basic
10 109113 RK	R-7,200	Residential 7,200 sq. ft.	SFR-Basic
10 109114 RK	R-7,200	Residential 7,200 sq. ft.	SFR-Basic
10 109115 RK	R-7,200	Residential 7,200 sq. ft.	SFR-Basic
10 109108 RK	R-7,200	Residential 7,200 sq. ft.	SFR-Basic
10 109107 RK	R-7,200	Residential 7,200 sq. ft.	SFR-Basic
10 109116 RK	R-7,200	Residential 7,200 sq. ft.	SFR-Basic
10 109117 RK	R-7,200	Residential 7,200 sq. ft.	SFR-Basic
10 101713 RK	R-5	Rural-5 Acre	Single Family Residential
11 101157 RK	R-5	Rural-5 Acre	Single Family Residential
10 108801 RK	R-5	Rural-5 Acre	Single Family Residential

Accessory Dwelling Units

Index # - File Name: 1.0022 - Single Family Dwellings Data\_Snohomish County.pdf

11 104387 RK	R-7,200	Residential 7,200 sq. ft.	Single Family Residential
10 108911 RK	R-7,200	Residential 7,200 sq. ft.	Single Family Residential
11 109599 RK	R-7,200	Residential 7,200 sq. ft.	Single Family Residential
11 104141 RK	R-5	Rural-5 Acre	Single Family Residential
11 105229 RK	R-5	Rural-5 Acre	Single Family Residential
11 104091 RK	R-5	Rural-5 Acre	Single Family Residential
11 107829 RK	R-5	Rural-5 Acre	Single Family Residential
11 100622 RK	R-7,200	Residential 7,200 sq. ft.	SFR-Basic
10 109572 RK	R-7,200	Residential 7,200 sq. ft.	SFR-Basic
10 109573 RK	R-7,200	Residential 7,200 sq. ft.	SFR-Basic
10 109574 RK	R-7,200	Residential 7,200 sq. ft.	SFR-Basic
10 109575 RK	R-7,200	Residential 7,200 sq. ft.	SFR-Basic
10 109576 RK	R-7,200	Residential 7,200 sq. ft.	SFR-Basic
11 103757 RK	R-5	Rural-5 Acre	Single Family Residential
10 109222 RK	R-7,200(PRD)	Residential 7,200 sq. ft.	SFR-Basic
10 109221 RK	R-7,200(PRD)	Residential 7,200 sq. ft.	SFR-Basic
10 104497 RK	R-7,200(PRD)	Residential 7,200 sq. ft.	SFR-Basic
11 103619 RK	R-7,200(PRD)	Residential 7,200 sq. ft.	Single Family Residential
10 109433 RK	R-7,200(PRD)	Residential 7,200 sq. ft.	SFR-Basic
10 109434 RK	R-7,200(PRD)	Residential 7,200 sq. ft.	SFR-Basic
10 109435 RK	R-7,200(PRD)	Residential 7,200 sq. ft.	SFR-Basic
10 109436 RK	R-7,200(PRD)	Residential 7,200 sq. ft.	SFR-Basic
10 109437 RK	R-7,200(PRD)	Residential 7,200 sq. ft.	SFR-Basic
10 109438 RK	R-7,200(PRD)	Residential 7,200 sq. ft.	SFR-Basic
10 109430 RK	R-7,200(PRD)	Residential 7,200 sq. ft.	SFR-Basic
10 109431 RK	R-7,200(PRD)	Residential 7,200 sq. ft.	SFR-Basic
10 109432 RK	R-7,200(PRD)	Residential 7,200 sq. ft.	SFR-Basic
11 103913 RK	R-7,200	Residential 7,200 sq. ft.	Single Family Residential
11 105306 RK	R-7,200	Residential 7,200 sq. ft.	Single Family Residential
11 102836 RK	R-7,200	Residential 7,200 sq. ft.	Single Family Residential
11 104082 RK	R-7,200	Residential 7,200 sq. ft.	Single Family Residential
11 104080 RK	R-7,200	Residential 7,200 sq. ft.	Single Family Residential
11 100987 RK	R-7,200	Residential 7,200 sq. ft.	Single Family Residential
11 108619 RK	R-7,200	Residential 7,200 sq. ft.	Single Family Residential
11 103912 RK	R-7,200	Residential 7,200 sq. ft.	Single Family Residential
11 102837 RK	R-7,200	Residential 7,200 sq. ft.	Single Family Residential
10 106943 RK	LDMR	Low Density Multiple Reside	SFR-Basic
10 106944 RK	LDMR	Low Density Multiple Reside	SFR-Basic
11 104296 RK	R-7,200	Residential 7,200 sq. ft.	Single Family Residential
11 104943 RK	R-7,200	Residential 7,200 sq. ft.	Single Family Residential
11 100896 RK	LDMR	Low Density Multiple Reside	SFR-Basic
11 100895 RK	LDMR	Low Density Multiple Reside	SFR-Basic
10 105023 RK	LDMR	Low Density Multiple Reside	SFR-Basic
11 101524 RK	LDMR	Low Density Multiple Reside	SFR-Basic
11 102437 RK	LDMR	Low Density Multiple Reside	Single Family Residential
11 103184 RK	LDMR	Low Density Multiple Reside	Single Family Residential
11 103185 RK	LDMR	Low Density Multiple Reside	Single Family Residential

Accessory Dwelling Units

Index # - File Name: 1.0022 - Single Family Dwellings Data\_Snohomish County.pdf

11 108784 RK	PRD-9,600	Residential 9,600 sq. ft.	SFR-Basic
10 104840 RK	MR	Multiple Residential	Single Family Residential
11 105153 RK	R-5	Rural-5 Acre	Single Family Residential
11 107784 RK	R-7,200	Residential 7,200 sq. ft.	SFR-Basic
11 107783 RK	R-7,200	Residential 7,200 sq. ft.	SFR-Basic
11 107427 RK	R-7,200	Residential 7,200 sq. ft.	SFR-Basic
11 107785 RK	R-7,200	Residential 7,200 sq. ft.	SFR-Basic
10 109135 RK	R-5	Rural-5 Acre	Single Family Residential
11 102265 RK	R-7,200	Residential 7,200 sq. ft.	SFR-Basic
11 102921 RK	R-7,200	Residential 7,200 sq. ft.	SFR-Basic
11 102920 RK	R-7,200	Residential 7,200 sq. ft.	SFR-Basic
11 101191 RK	R-7,200	Residential 7,200 sq. ft.	SFR-Basic
11 106628 RK	R-7,200	Residential 7,200 sq. ft.	SFR-Basic
11 103750 RK	R-7,200	Residential 7,200 sq. ft.	SFR-Basic
11 108103 RK	MR	Multiple Residential	SFR-Basic
11 108104 RK	MR	Multiple Residential	SFR-Basic
11 107888 RK	MR	Multiple Residential	SFR-Basic
11 101632 RK	MR	Multiple Residential	Single Family Residential
11 107889 RK	MR	Multiple Residential	SFR-Basic
11 107890 RK	MR	Multiple Residential	SFR-Basic
10 108745 RK	R-7,200	Residential 7,200 sq. ft.	SFR-Basic
10 109446 RK	R-7,200	Residential 7,200 sq. ft.	SFR-Basic
10 108744 RK	R-7,200	Residential 7,200 sq. ft.	SFR-Basic
11 109143 RK	R-7,200	Residential 7,200 sq. ft.	SFR-Basic
11 109146 RK	R-7,200	Residential 7,200 sq. ft.	SFR-Basic
11 109148 RK	R-7,200	Residential 7,200 sq. ft.	SFR-Basic
11 109149 RK	R-7,200	Residential 7,200 sq. ft.	SFR-Basic
11 109144 RK	R-7,200	Residential 7,200 sq. ft.	SFR-Basic
11 108204 RK	R-7,200	Residential 7,200 sq. ft.	SFR-Basic
11 108547 RK	R-7,200	Residential 7,200 sq. ft.	SFR-Basic
11 101565 RK	R-5	Rural-5 Acre	SFR-Basic
11 101567 RK	R-5	Rural-5 Acre	SFR-Basic
11 107108 RK	R-5	Rural-5 Acre	SFR-Basic
11 107106 RK	R-5	Rural-5 Acre	SFR-Basic
10 106691 RK	R-5	Rural-5 Acre	SFR-Basic
10 106694 RK	R-5	Rural-5 Acre	SFR-Basic
10 106690 RK	R-5	Rural-5 Acre	SFR-Basic
10 102559 RK	R-9,600	Residential 9,600 sq. ft.	SFR-Basic
10 102560 RK	R-9,600	Residential 9,600 sq. ft.	SFR-Basic
10 102561 RK	R-9,600	Residential 9,600 sq. ft.	SFR-Basic
10 103337 RK	R-9,600	Residential 9,600 sq. ft.	SFR-Basic
10 103338 RK	R-9,600	Residential 9,600 sq. ft.	SFR-Basic
10 103339 RK	R-9,600	Residential 9,600 sq. ft.	SFR-Basic
10 103340 RK	R-9,600	Residential 9,600 sq. ft.	SFR-Basic
10 103341 RK	R-9,600	Residential 9,600 sq. ft.	SFR-Basic
10 103342 RK	R-9,600	Residential 9,600 sq. ft.	SFR-Basic
10 103530 RK	R-9,600	Residential 9,600 sq. ft.	SFR-Basic

Accessory Dwelling Units

Index # - File Name: 1.0022 - Single Family Dwellings Data\_Snohomish County.pdf

10 103531 RK	R-9,600	Residential 9,600 sq. ft.	SFR-Basic
10 103532 RK	R-9,600	Residential 9,600 sq. ft.	SFR-Basic
10 103533 RK	R-9,600	Residential 9,600 sq. ft.	SFR-Basic
10 103534 RK	R-9,600	Residential 9,600 sq. ft.	SFR-Basic
10 103535 RK	R-9,600	Residential 9,600 sq. ft.	SFR-Basic
10 103536 RK	R-9,600	Residential 9,600 sq. ft.	SFR-Basic
10 103537 RK	R-9,600	Residential 9,600 sq. ft.	SFR-Basic
10 103538 RK	R-9,600	Residential 9,600 sq. ft.	SFR-Basic
10 103733 RK	R-9,600	Residential 9,600 sq. ft.	SFR-Basic
10 103734 RK	R-9,600	Residential 9,600 sq. ft.	SFR-Basic
10 102564 RK	R-9,600	Residential 9,600 sq. ft.	SFR-Basic
10 104784 RK	R-9,600	Residential 9,600 sq. ft.	SFR-Basic
10 103736 RK	R-9,600	Residential 9,600 sq. ft.	SFR-Basic
10 103737 RK	R-9,600	Residential 9,600 sq. ft.	SFR-Basic
10 103738 RK	R-9,600	Residential 9,600 sq. ft.	SFR-Basic
10 103739 RK	R-9,600	Residential 9,600 sq. ft.	SFR-Basic
10 103740 RK	R-9,600	Residential 9,600 sq. ft.	SFR-Basic
10 102420 RK	R-9,600	Residential 9,600 sq. ft.	SFR-Basic
10 108735 RK	R-8,400	Residential 8,400 sq. ft.	Single Family Residential
11 103587 RK	R-9,600	Residential 9,600 sq. ft.	SFR-Basic
10 104785 RK	R-9,600	Residential 9,600 sq. ft.	SFR-Basic
10 104786 RK	R-9,600	Residential 9,600 sq. ft.	SFR-Basic
10 103743 RK	R-9,600	Residential 9,600 sq. ft.	SFR-Basic
10 104787 RK	R-9,600	Residential 9,600 sq. ft.	SFR-Basic
10 103539 RK	R-9,600	Residential 9,600 sq. ft.	SFR-Basic
10 109046 RK	R-7,200	Residential 7,200 sq. ft.	SFR-Basic
10 109047 RK	R-7,200	Residential 7,200 sq. ft.	SFR-Basic
10 109048 RK	R-7,200	Residential 7,200 sq. ft.	SFR-Basic
10 109049 RK	R-7,200	Residential 7,200 sq. ft.	SFR-Basic
10 109045 RK	R-7,200	Residential 7,200 sq. ft.	SFR-Basic
11 107691 RK	R-7,200	Residential 7,200 sq. ft.	Single Family Residential
11 104589 RK	R-5	Rural-5 Acre	Single Family Residential
10 108823 RK	R-5	Rural-5 Acre	SFR-Basic
10 102408 RK	R-9,600	Residential 9,600 sq. ft.	SFR-Basic
10 102409 RK	R-9,600	Residential 9,600 sq. ft.	SFR-Basic
10 103344 RK	R-9,600	Residential 9,600 sq. ft.	SFR-Basic
10 102407 RK	R-9,600	Residential 9,600 sq. ft.	SFR-Basic
10 102416 RK	R-9,600	Residential 9,600 sq. ft.	SFR-Basic
11 107692 RK	R-7,200	Residential 7,200 sq. ft.	Single Family Residential
10 109042 RK	R-7,200	Residential 7,200 sq. ft.	SFR-Basic
10 109043 RK	R-7,200	Residential 7,200 sq. ft.	SFR-Basic
10 109044 RK	R-7,200	Residential 7,200 sq. ft.	SFR-Basic
10 109503 RK	R-5	Rural-5 Acre	Single Family Residential
11 105203 RK	R-5	Rural-5 Acre	Single Family Residential
10 109188 MH	R-5	Rural-5 Acre	Double Wide
10 104041 000 01 RK	R-7,200	Residential 7,200 sq. ft.	SFR-Basic
10 104610 RK	R-7,200	Residential 7,200 sq. ft.	Single Family Residential



Accessory Dwelling Units

Index # - File Name: 1.0022 - Single Family Dwellings Data\_Snohomish County.pdf

11 105294 RK	LDMR	Low Density Multiple Reside	SFR-Basic
11 101677 RK	R-7,200	Residential 7,200 sq. ft.	Single Family Residential
11 109251 RK	R-7,200	Residential 7,200 sq. ft.	Single Family Residential
10 104754 RK	MR	Multiple Residential	SFR-Basic
10 104752 RK	MR	Multiple Residential	SFR-Basic
10 104753 RK	MR	Multiple Residential	SFR-Basic
11 107390 RK	R-7,200(PRD)	Residential 7,200 sq. ft.	SFR-Basic
11 107391 RK	R-7,200(PRD)	Residential 7,200 sq. ft.	SFR-Basic
11 107389 RK	R-7,200(PRD)	Residential 7,200 sq. ft.	SFR-Basic
11 107392 RK	R-7,200(PRD)	Residential 7,200 sq. ft.	Single Family Residential
10 108987 RK	R-7,200	Residential 7,200 sq. ft.	SFR-Basic
10 109169 RK	R-7,200	Residential 7,200 sq. ft.	SFR-Basic
10 109175 RK	R-7,200	Residential 7,200 sq. ft.	SFR-Basic
10 109170 RK	R-7,200	Residential 7,200 sq. ft.	SFR-Basic
10 109176 RK	R-7,200	Residential 7,200 sq. ft.	SFR-Basic
10 109172 RK	R-7,200	Residential 7,200 sq. ft.	SFR-Basic
10 109178 RK	R-7,200	Residential 7,200 sq. ft.	SFR-Basic
10 109168 RK	R-7,200	Residential 7,200 sq. ft.	SFR-Basic
10 109183 RK	R-7,200	Residential 7,200 sq. ft.	SFR-Basic
10 109167 RK	R-7,200	Residential 7,200 sq. ft.	SFR-Basic
10 109184 RK	R-7,200	Residential 7,200 sq. ft.	SFR-Basic
10 109181 RK	R-7,200	Residential 7,200 sq. ft.	SFR-Basic
10 109173 RK	R-7,200	Residential 7,200 sq. ft.	SFR-Basic
10 109162 RK	R-7,200	Residential 7,200 sq. ft.	SFR-Basic
10 109186 RK	R-7,200	Residential 7,200 sq. ft.	SFR-Basic
10 109161 RK	R-7,200	Residential 7,200 sq. ft.	SFR-Basic
10 109164 RK	R-7,200	Residential 7,200 sq. ft.	SFR-Basic
10 109163 RK	R-7,200	Residential 7,200 sq. ft.	SFR-Basic
10 109180 RK	R-7,200	Residential 7,200 sq. ft.	SFR-Basic
10 108985 RK	R-7,200	Residential 7,200 sq. ft.	SFR-Basic
10 108563 RK	R-7,200	Residential 7,200 sq. ft.	SFR-Basic
10 108564 RK	R-7,200	Residential 7,200 sq. ft.	SFR-Basic
10 108561 RK	R-7,200	Residential 7,200 sq. ft.	SFR-Basic
10 109165 RK	R-7,200	Residential 7,200 sq. ft.	SFR-Basic
11 102813 RK	R-5	Rural-5 Acre	Single Family Residential
10 104624 RK	R-5	Rural-5 Acre	Single Family Residential
11 104788 RK	R-7,200(PRD)	Residential 7,200 sq. ft.	SFR-Basic
11 107430 RK	R-7,200(PRD)	Residential 7,200 sq. ft.	SFR-Basic
11 103417 RK	R-7,200(PRD)	Residential 7,200 sq. ft.	SFR-Basic
11 103218 RK	R-9,600	Residential 9,600 sq. ft.	SFR-Basic
11 105946 RK	R-7,200(PRD)	Residential 7,200 sq. ft.	SFR-Basic
11 103418 RK	R-7,200(PRD)	Residential 7,200 sq. ft.	SFR-Basic
11 101520 RK	R-9,600	Residential 9,600 sq. ft.	SFR-Basic
10 104925 RK	R-7,200(PRD)	Residential 7,200 sq. ft.	SFR-Basic
10 104926 RK	R-7,200(PRD)	Residential 7,200 sq. ft.	SFR-Basic
10 104924 RK	R-7,200(PRD)	Residential 7,200 sq. ft.	SFR-Basic
11 108712 RK	R-7,200(PRD)	Residential 7,200 sq. ft.	SFR-Basic

Accessory Dwelling Units

Index # - File Name: 1.0022 - Single Family Dwellings Data\_Snohomish County.pdf

11 105867 RK	R-7,200	Residential 7,200 sq. ft.	SFR-Basic
11 105864 RK	R-7,200	Residential 7,200 sq. ft.	SFR-Basic
11 105868 RK	R-7,200	Residential 7,200 sq. ft.	SFR-Basic
11 105865 RK	R-7,200	Residential 7,200 sq. ft.	SFR-Basic
10 108762 RK	R-5	Rural-5 Acre	SFR-Basic
10 108758 RK	R-5	Rural-5 Acre	SFR-Basic
10 108759 RK	R-5	Rural-5 Acre	SFR-Basic
10 108761 RK	R-5	Rural-5 Acre	SFR-Basic
10 103954 RK	LDMR	Low Density Multiple Reside	SFR-Basic
10 103955 RK	LDMR	Low Density Multiple Reside	SFR-Basic
10 103956 RK	LDMR	Low Density Multiple Reside	SFR-Basic
10 103957 RK	LDMR	Low Density Multiple Reside	SFR-Basic
10 103958 RK	LDMR	Low Density Multiple Reside	SFR-Basic
10 100959 RK	R-7,200	Residential 7,200 sq. ft.	Single Family Residential
10 104339 RK	R-7,200	Residential 7,200 sq. ft.	Single Family Residential
10 104348 RK	R-7,200	Residential 7,200 sq. ft.	Single Family Residential
10 103943 RK	LDMR	Low Density Multiple Reside	SFR-Basic
10 103948 RK	LDMR	Low Density Multiple Reside	SFR-Basic
10 103949 RK	LDMR	Low Density Multiple Reside	SFR-Basic
10 103950 RK	LDMR	Low Density Multiple Reside	SFR-Basic
10 105005 RK	R-7,200(PRD)	Residential 7,200 sq. ft.	SFR-Basic
10 105011 RK	R-7,200(PRD)	Residential 7,200 sq. ft.	SFR-Basic
10 105015 RK	R-7,200(PRD)	Residential 7,200 sq. ft.	SFR-Basic
10 105016 RK	R-7,200(PRD)	Residential 7,200 sq. ft.	SFR-Basic
10 105008 RK	R-7,200(PRD)	Residential 7,200 sq. ft.	SFR-Basic
11 100976 RK	R-7,200(PRD)	Residential 7,200 sq. ft.	SFR-Basic
11 104405 RK	R-7,200(PRD)	Residential 7,200 sq. ft.	SFR-Basic
11 101463 RK	R-7,200(PRD)	Residential 7,200 sq. ft.	SFR-Basic
10 105013 RK	R-7,200(PRD)	Residential 7,200 sq. ft.	SFR-Basic
10 104775 RK	R-7,200(PRD)	Residential 7,200 sq. ft.	SFR-Basic
11 104404 RK	R-7,200(PRD)	Residential 7,200 sq. ft.	SFR-Basic
11 104009 RK	R-7,200(PRD)	Residential 7,200 sq. ft.	SFR-Basic
11 109394 RK	R-7,200(PRD)	Residential 7,200 sq. ft.	SFR-Basic
10 105007 RK	R-7,200(PRD)	Residential 7,200 sq. ft.	SFR-Basic
11 100977 RK	R-7,200(PRD)	Residential 7,200 sq. ft.	SFR-Basic
10 105020 RK	R-7,200(PRD)	Residential 7,200 sq. ft.	SFR-Basic
11 105938 RK	R-7,200(PRD)	Residential 7,200 sq. ft.	SFR-Basic
10 109507 RK	R-5	Rural-5 Acre	Single Family Residential
10 109515 RK	R-5	Rural-5 Acre	Single Family Residential
10 109506 RK	R-5	Rural-5 Acre	Single Family Residential
10 109504 RK	R-5	Rural-5 Acre	Single Family Residential
10 109508 RK	R-5	Rural-5 Acre	Single Family Residential
10 109514 RK	R-5	Rural-5 Acre	Single Family Residential
10 109505 RK	R-5	Rural-5 Acre	Single Family Residential
11 104930 RK	R-5	Rural-5 Acre	Single Family Residential
11 102179 RK	R-5	Rural-5 Acre	Single Family Residential
10 107530 RK	R-7,200	Residential 7,200 sq. ft.	SFR-Basic

Accessory Dwelling Units

Index # - File Name: 1.0022 - Single Family Dwellings Data\_Snohomish County.pdf

10 104959 RK	R-7,200	Residential 7,200 sq. ft.	SFR-Basic
11 104489 RK	R-7,200	Residential 7,200 sq. ft.	Single Family Residential
11 103819 RK	R-7,200	Residential 7,200 sq. ft.	Single Family Residential
10 106697 RK	R-5	Rural-5 Acre	SFR-Basic
11 103820 RK	R-7,200	Residential 7,200 sq. ft.	Single Family Residential
10 104974 RK	R-7,200	Residential 7,200 sq. ft.	SFR-Basic
10 104975 RK	R-7,200	Residential 7,200 sq. ft.	SFR-Basic
10 104976 RK	R-7,200	Residential 7,200 sq. ft.	SFR-Basic
10 104977 RK	R-7,200	Residential 7,200 sq. ft.	SFR-Basic
10 104954 RK	R-7,200	Residential 7,200 sq. ft.	SFR-Basic
10 104971 RK	R-7,200	Residential 7,200 sq. ft.	SFR-Basic
10 104972 RK	R-7,200	Residential 7,200 sq. ft.	SFR-Basic
10 104973 RK	R-7,200	Residential 7,200 sq. ft.	SFR-Basic
10 104963 RK	R-7,200	Residential 7,200 sq. ft.	SFR-Basic
10 104964 RK	R-7,200	Residential 7,200 sq. ft.	SFR-Basic
10 104965 RK	R-7,200	Residential 7,200 sq. ft.	SFR-Basic
10 104966 RK	R-7,200	Residential 7,200 sq. ft.	SFR-Basic
10 104967 RK	R-7,200	Residential 7,200 sq. ft.	SFR-Basic
10 104968 RK	R-7,200	Residential 7,200 sq. ft.	SFR-Basic
10 104969 RK	R-7,200	Residential 7,200 sq. ft.	SFR-Basic
10 104970 RK	R-7,200	Residential 7,200 sq. ft.	SFR-Basic
10 108917 RK	R-7,200	Residential 7,200 sq. ft.	Single Family Residential
11 105301 RK	R-7,200	Residential 7,200 sq. ft.	SFR-Basic
11 101633 RK	R-7,200	Residential 7,200 sq. ft.	SFR-Basic
11 101634 RK	R-7,200	Residential 7,200 sq. ft.	SFR-Basic
11 105354 RK	R-7,200	Residential 7,200 sq. ft.	SFR-Basic
11 101514 RK	R-7,200	Residential 7,200 sq. ft.	SFR-Basic
11 102918 RK	R-7,200	Residential 7,200 sq. ft.	SFR-Basic
11 105302 RK	R-7,200	Residential 7,200 sq. ft.	SFR-Basic
11 105999 RK	R-7,200	Residential 7,200 sq. ft.	SFR-Basic
11 101988 RK	R-7,200	Residential 7,200 sq. ft.	SFR-Basic
11 104629 RK	R-7,200	Residential 7,200 sq. ft.	SFR-Basic
11 104849 RK	R-7,200	Residential 7,200 sq. ft.	SFR-Basic
11 105353 RK	R-7,200	Residential 7,200 sq. ft.	SFR-Basic
11 104194 RK	R-7,200	Residential 7,200 sq. ft.	SFR-Basic
11 109129 RK	R-7,200(PRD)	Residential 7,200 sq. ft.	Single Family Residential
11 107894 RK	R-7,200(PRD)	Residential 7,200 sq. ft.	Single Family Residential
11 104630 RK	R-7,200	Residential 7,200 sq. ft.	SFR-Basic
11 106726 RK	R-7,200(PRD)	Residential 7,200 sq. ft.	Single Family Residential
11 106193 RK	R-7,200(PRD)	Residential 7,200 sq. ft.	Single Family Residential
11 107023 RK	R-7,200(PRD)	Residential 7,200 sq. ft.	Single Family Residential
11 108266 RK	R-7,200(PRD)	Residential 7,200 sq. ft.	Single Family Residential
11 107464 RK	R-7,200(PRD)	Residential 7,200 sq. ft.	Single Family Residential
11 108793 RK	R-7,200(PRD)	Residential 7,200 sq. ft.	Single Family Residential
11 105329 RK	PRD-7,200	Residential 7,200 sq. ft.	Single Family Residential
11 105324 RK	PRD-7,200	Residential 7,200 sq. ft.	Single Family Residential
11 105330 RK	PRD-7,200	Residential 7,200 sq. ft.	Single Family Residential

Accessory Dwelling Units

Index # - File Name: 1.0022 - Single Family Dwellings Data\_Snohomish County.pdf

11 105327 RK	PRD-7,200	Residential 7,200 sq. ft.	Single Family Residential
11 105326 RK	PRD-7,200	Residential 7,200 sq. ft.	Single Family Residential
11 105328 RK	PRD-7,200	Residential 7,200 sq. ft.	Single Family Residential
10 108918 RK	R-7,200	Residential 7,200 sq. ft.	Single Family Residential
10 108916 RK	R-7,200	Residential 7,200 sq. ft.	Single Family Residential
10 108919 RK	R-7,200	Residential 7,200 sq. ft.	Single Family Residential
11 105796 RK	R-7,200	Residential 7,200 sq. ft.	SFR-Basic
11 102634 RK	R-7,200	Residential 7,200 sq. ft.	SFR-Basic
11 105365 RK	R-7,200	Residential 7,200 sq. ft.	Single Family Residential
11 108200 RK	R-7,200	Residential 7,200 sq. ft.	SFR-Basic
11 101987 RK	R-7,200	Residential 7,200 sq. ft.	SFR-Basic
11 101195 RK	R-7,200	Residential 7,200 sq. ft.	SFR-Basic
11 101513 RK	R-7,200	Residential 7,200 sq. ft.	SFR-Basic
11 100724 RK	R-7,200	Residential 7,200 sq. ft.	SFR-Basic
11 100725 RK	R-7,200	Residential 7,200 sq. ft.	SFR-Basic
11 100726 RK	R-7,200	Residential 7,200 sq. ft.	SFR-Basic
11 105515 RK	R-7,200	Residential 7,200 sq. ft.	SFR-Basic
11 103285 RK	R-7,200	Residential 7,200 sq. ft.	Single Family Residential
10 104609 RK	R-7,200	Residential 7,200 sq. ft.	Single Family Residential
11 108327 RK	LDMR	Low Density Multiple Reside	SFR-Basic
11 108328 RK	LDMR	Low Density Multiple Reside	SFR-Basic
11 108323 RK	LDMR	Low Density Multiple Reside	SFR-Basic
11 108324 RK	LDMR	Low Density Multiple Reside	SFR-Basic
11 108325 RK	LDMR	Low Density Multiple Reside	SFR-Basic
11 109132 RK	LDMR	Low Density Multiple Reside	SFR-Basic
11 109133 RK	LDMR	Low Density Multiple Reside	SFR-Basic
11 109134 RK	LDMR	Low Density Multiple Reside	SFR-Basic
11 100870 RK	R-7,200	Residential 7,200 sq. ft.	Single Family Residential
11 100868 RK	R-7,200	Residential 7,200 sq. ft.	Single Family Residential
11 105597 RK	RRT-10	Rural Resource Transition-10	Single Family Residential
11 107757 RK	R-7,200(PRD)	Residential 7,200 sq. ft.	Single Family Residential
11 108792 RK	R-7,200(PRD)	Residential 7,200 sq. ft.	Single Family Residential
11 102662 RK	R-5	Rural-5 Acre	SFR-Basic
11 102663 RK	R-5	Rural-5 Acre	SFR-Basic
11 108326 RK	LDMR	Low Density Multiple Reside	SFR-Basic
10 109284 RK	R-5	Rural-5 Acre	SFR-Basic
10 108907 RK	R-5	Rural-5 Acre	SFR-Basic
10 104598 RK	R-5	Rural-5 Acre	SFR-Basic
10 109536 RK	R-5	Rural-5 Acre	SFR-Basic
11 101142 RK	R-5	Rural-5 Acre	SFR-Basic
10 108908 RK	R-5	Rural-5 Acre	SFR-Basic
11 103708 RK	R-5	Rural-5 Acre	Single Family Residential
11 103709 RK	R-5	Rural-5 Acre	Single Family Residential
11 104065 RK	R-5	Rural-5 Acre	Single Family Residential
11 107093 RK	R-5	Rural-5 Acre	Single Family Residential
11 107019 RK	R-5	Rural-5 Acre	Single Family Residential
11 101573 RK	R-5	Rural-5 Acre	SFR-Basic

Accessory Dwelling Units

Index # - File Name: 1.0022 - Single Family Dwellings Data\_Snohomish County.pdf

11 105686 RK	R-7,200	Residential 7,200 sq. ft.	Single Family Residential
10 109552 RK	LDMR	Low Density Multiple Reside	Single Family Residential
10 109548 RK	LDMR	Low Density Multiple Reside	SFR-Basic
10 109542 RK	LDMR	Low Density Multiple Reside	Duplex-Basic
10 109543 RK	LDMR	Low Density Multiple Reside	Duplex-Basic
10 109544 RK	LDMR	Low Density Multiple Reside	Duplex-Basic
10 109550 RK	LDMR	Low Density Multiple Reside	Single Family Residential
10 109547 RK	LDMR	Low Density Multiple Reside	SFR-Basic
11 101479 RK	R-5	Rural-5 Acre	Single Family Residential
11 104782 RK	R-5	Rural-5 Acre	SFR-Basic
11 105853 RK	R-5	Rural-5 Acre	Single Family Residential
11 108691 RK	R-5	Rural-5 Acre	SFR-Basic
09 105321 RK	R-5	Rural-5 Acre	Single Family Residential
10 109546 RK	LDMR	Low Density Multiple Reside	SFR-Basic
10 109551 RK	LDMR	Low Density Multiple Reside	Single Family Residential
11 101144 RK	R-7,200	Residential 7,200 sq. ft.	Single Family Residential
11 104781 RK	R-5	Rural-5 Acre	SFR-Basic
11 104780 RK	R-5	Rural-5 Acre	SFR-Basic
10 109557 RK	R-5	Rural-5 Acre	SFR-Basic
10 109372 RK	R-5	Rural-5 Acre	SFR-Basic
10 109556 RK	R-5	Rural-5 Acre	SFR-Basic
10 109368 RK	R-5	Rural-5 Acre	SFR-Basic
10 109369 RK	R-5	Rural-5 Acre	SFR-Basic
10 109370 RK	R-5	Rural-5 Acre	SFR-Basic
11 107679 RK	R-7,200	Residential 7,200 sq. ft.	Single Family Residential
11 108013 RK	R-7,200	Residential 7,200 sq. ft.	Single Family Residential
11 106300 RK	R-7,200	Residential 7,200 sq. ft.	Single Family Residential
11 104985 RK	R-7,200	Residential 7,200 sq. ft.	Single Family Residential
11 102277 RK	R-7,200	Residential 7,200 sq. ft.	Single Family Residential
11 105563 RK	R-7,200	Residential 7,200 sq. ft.	SFR-Basic
11 104299 RK	R-7,200	Residential 7,200 sq. ft.	Single Family Residential
11 103102 RK	R-7,200	Residential 7,200 sq. ft.	Single Family Residential
11 107681 RK	R-7,200	Residential 7,200 sq. ft.	SFR-Basic
10 102499 RK	R-7,200	Residential 7,200 sq. ft.	Single Family Residential
11 107414 RK	LDMR	Low Density Multiple Reside	Single Family Residential
10 102500 RK	R-7,200	Residential 7,200 sq. ft.	Single Family Residential
11 105438 RK	R-7,200	Residential 7,200 sq. ft.	SFR-Basic
11 105437 RK	R-7,200	Residential 7,200 sq. ft.	SFR-Basic
11 101810 RK	R-7,200	Residential 7,200 sq. ft.	Single Family Residential
10 104844 RK	MR	Multiple Residential	Single Family Residential
11 105001 RK	R-9,600	Residential 9,600 sq. ft.	SFR-Basic
11 105002 RK	R-9,600	Residential 9,600 sq. ft.	SFR-Basic
10 104814 RK	MR	Multiple Residential	Single Family Residential
10 104815 RK	MR	Multiple Residential	Single Family Residential
10 104816 RK	MR	Multiple Residential	Single Family Residential
10 104841 RK	MR	Multiple Residential	Single Family Residential
10 104842 RK	MR	Multiple Residential	Single Family Residential

Accessory Dwelling Units

Index # - File Name: 1.0022 - Single Family Dwellings Data\_Snohomish County.pdf

10 104843 RK	MR	Multiple Residential	Single Family Residential
10 104845 RK	MR	Multiple Residential	Single Family Residential
10 104848 RK	MR	Multiple Residential	Single Family Residential
10 104849 RK	MR	Multiple Residential	Single Family Residential
10 104819 RK	MR	Multiple Residential	Single Family Residential
10 104820 RK	MR	Multiple Residential	Single Family Residential
10 104821 RK	MR	Multiple Residential	Single Family Residential
11 102385 RK	R-9,600	Residential 9,600 sq. ft.	SFR-Basic
11 102386 RK	R-9,600	Residential 9,600 sq. ft.	SFR-Basic
11 102387 RK	R-9,600	Residential 9,600 sq. ft.	Single Family Residential
10 104797 RK	MR	Multiple Residential	Single Family Residential
10 104818 RK	MR	Multiple Residential	Single Family Residential
10 106914 000 01 RK	R-5	Rural-5 Acre	Single Family Residential
11 100064 RK	R-7,200	Residential 7,200 sq. ft.	SFR-Basic
11 100065 RK	R-7,200	Residential 7,200 sq. ft.	SFR-Basic
11 100066 RK	R-7,200	Residential 7,200 sq. ft.	SFR-Basic
11 102932 RK	R-7,200	Residential 7,200 sq. ft.	SFR-Basic
11 102933 RK	R-7,200	Residential 7,200 sq. ft.	SFR-Basic
11 102934 RK	R-7,200	Residential 7,200 sq. ft.	SFR-Basic
11 102935 RK	R-7,200	Residential 7,200 sq. ft.	SFR-Basic
11 102936 RK	R-7,200	Residential 7,200 sq. ft.	SFR-Basic
11 102937 RK	R-7,200	Residential 7,200 sq. ft.	SFR-Basic
11 102938 RK	R-7,200	Residential 7,200 sq. ft.	SFR-Basic
11 104451 RK	R-7,200	Residential 7,200 sq. ft.	SFR-Basic
11 104450 RK	R-7,200	Residential 7,200 sq. ft.	SFR-Basic
11 104445 RK	R-7,200	Residential 7,200 sq. ft.	SFR-Basic
11 104446 RK	R-7,200	Residential 7,200 sq. ft.	SFR-Basic
11 104447 RK	R-7,200	Residential 7,200 sq. ft.	SFR-Basic
11 104449 RK	R-7,200	Residential 7,200 sq. ft.	SFR-Basic
11 100061 RK	R-7,200	Residential 7,200 sq. ft.	SFR-Basic
11 100063 RK	R-7,200	Residential 7,200 sq. ft.	SFR-Basic
10 108821 000 01 RK	R-5	Rural-5 Acre	SFR-Basic
11 108442 RK	R-5	Rural-5 Acre	Single Family Residential
11 108445 RK	R-5	Rural-5 Acre	Single Family Residential
10 108820 RK	R-5	Rural-5 Acre	SFR-Basic
11 107396 RK	R-9,600	Residential 9,600 sq. ft.	Single Family Residential
10 104593 RK	R-7,200	Residential 7,200 sq. ft.	Single Family Residential
11 100060 RK	R-7,200	Residential 7,200 sq. ft.	SFR-Basic
10 109069 RK	R-7,200	Residential 7,200 sq. ft.	SFR-Basic
11 101707 RK	R-5	Rural-5 Acre	SFR-Basic
11 105628 RK	R-9,600	Residential 9,600 sq. ft.	SFR-Basic
11 107394 RK	R-9,600	Residential 9,600 sq. ft.	SFR-Basic
11 103169 RK	LDMR	Low Density Multiple Reside	SFR-Basic
11 105626 RK	R-9,600	Residential 9,600 sq. ft.	SFR-Basic
11 105627 RK	R-9,600	Residential 9,600 sq. ft.	SFR-Basic
11 103168 RK	LDMR	Low Density Multiple Reside	SFR-Basic
11 103166 RK	LDMR	Low Density Multiple Reside	SFR-Basic

Accessory Dwelling Units

Index # - File Name: 1.0022 - Single Family Dwellings Data\_Snohomish County.pdf

11 103165 RK	LDMR	Low Density Multiple Reside	SFR-Basic
11 104272 RK	LDMR	Low Density Multiple Reside	Single Family Residential
11 104273 RK	LDMR	Low Density Multiple Reside	SFR-Basic
11 104274 RK	LDMR	Low Density Multiple Reside	SFR-Basic
11 101659 RK	R-7,200	Residential 7,200 sq. ft.	SFR-Basic
11 101192 RK	R-7,200	Residential 7,200 sq. ft.	SFR-Basic
10 109447 RK	R-7,200	Residential 7,200 sq. ft.	SFR-Basic
11 100776 RK	R-7,200	Residential 7,200 sq. ft.	SFR-Basic
11 100777 RK	R-7,200	Residential 7,200 sq. ft.	SFR-Basic
11 105355 RK	R-7,200	Residential 7,200 sq. ft.	SFR-Basic
11 105356 RK	R-7,200	Residential 7,200 sq. ft.	SFR-Basic
11 107786 RK	R-7,200	Residential 7,200 sq. ft.	SFR-Basic
10 109448 RK	R-7,200	Residential 7,200 sq. ft.	SFR-Basic
10 109449 RK	R-7,200	Residential 7,200 sq. ft.	SFR-Basic
10 109450 RK	R-7,200	Residential 7,200 sq. ft.	SFR-Basic
11 100778 RK	R-7,200	Residential 7,200 sq. ft.	SFR-Basic
11 103751 RK	R-7,200	Residential 7,200 sq. ft.	SFR-Basic
11 102922 RK	R-7,200	Residential 7,200 sq. ft.	SFR-Basic
11 101660 RK	R-7,200	Residential 7,200 sq. ft.	SFR-Basic
11 101661 RK	R-7,200	Residential 7,200 sq. ft.	SFR-Basic
11 102266 RK	R-7,200	Residential 7,200 sq. ft.	SFR-Basic
11 106055 RK	R-7,200	Residential 7,200 sq. ft.	SFR-Basic
11 108548 RK	R-7,200	Residential 7,200 sq. ft.	SFR-Basic
11 105724 RK	R-7,200	Residential 7,200 sq. ft.	SFR-Basic
11 103752 RK	R-7,200	Residential 7,200 sq. ft.	SFR-Basic
11 106629 RK	R-7,200	Residential 7,200 sq. ft.	SFR-Basic
11 103753 RK	R-7,200	Residential 7,200 sq. ft.	SFR-Basic
10 108813 RK	R-5	Rural-5 Acre	Single Family Residential
11 107787 RK	R-7,200	Residential 7,200 sq. ft.	SFR-Basic
11 106630 RK	R-7,200	Residential 7,200 sq. ft.	SFR-Basic
11 107428 RK	R-7,200	Residential 7,200 sq. ft.	SFR-Basic
11 107429 RK	R-7,200	Residential 7,200 sq. ft.	SFR-Basic
11 109004 RK	R-7,200	Residential 7,200 sq. ft.	SFR-Basic
11 106978 RK	R-7,200	Residential 7,200 sq. ft.	SFR-Basic
11 106979 RK	R-7,200	Residential 7,200 sq. ft.	SFR-Basic
11 105358 RK	R-7,200	Residential 7,200 sq. ft.	SFR-Basic
11 106057 RK	R-7,200	Residential 7,200 sq. ft.	SFR-Basic
11 102923 RK	R-7,200	Residential 7,200 sq. ft.	SFR-Basic
11 102924 RK	R-7,200	Residential 7,200 sq. ft.	SFR-Basic
11 102925 RK	R-7,200	Residential 7,200 sq. ft.	SFR-Basic
11 102926 RK	R-7,200	Residential 7,200 sq. ft.	SFR-Basic
11 102927 RK	R-7,200	Residential 7,200 sq. ft.	SFR-Basic
11 102928 RK	R-7,200	Residential 7,200 sq. ft.	SFR-Basic
11 102929 RK	R-7,200	Residential 7,200 sq. ft.	SFR-Basic
11 101662 RK	R-7,200	Residential 7,200 sq. ft.	SFR-Basic
11 100779 RK	R-7,200	Residential 7,200 sq. ft.	SFR-Basic
11 102931 RK	R-7,200	Residential 7,200 sq. ft.	SFR-Basic

Accessory Dwelling Units

Index # - File Name: 1.0022 - Single Family Dwellings Data\_Snohomish County.pdf

11 100780 RK	R-7,200	Residential 7,200 sq. ft.	SFR-Basic
11 100781 RK	R-7,200	Residential 7,200 sq. ft.	SFR-Basic
11 100782 RK	R-7,200	Residential 7,200 sq. ft.	SFR-Basic
11 101663 RK	R-7,200	Residential 7,200 sq. ft.	SFR-Basic
11 101664 RK	R-7,200	Residential 7,200 sq. ft.	SFR-Basic
11 103754 RK	R-7,200	Residential 7,200 sq. ft.	SFR-Basic
11 100173 RK	R-5	Rural-5 Acre	Single Family Residential
11 107952 RK	R-7,200(PRD)	Residential 7,200 sq. ft.	SFR-Basic
11 107950 RK	R-7,200(PRD)	Residential 7,200 sq. ft.	SFR-Basic
11 103851 RK	R-7,200(PRD)	Residential 7,200 sq. ft.	SFR-Basic
11 103850 RK	R-7,200(PRD)	Residential 7,200 sq. ft.	SFR-Basic
11 103852 RK	R-7,200(PRD)	Residential 7,200 sq. ft.	Single Family Residential
11 100750 RK	R-5	Rural-5 Acre	Single Family Residential
11 101427 RK	R-7,200	Residential 7,200 sq. ft.	SFR-Basic
11 101430 RK	R-7,200	Residential 7,200 sq. ft.	SFR-Basic
11 101431 RK	R-7,200	Residential 7,200 sq. ft.	SFR-Basic
11 101432 RK	R-7,200	Residential 7,200 sq. ft.	SFR-Basic
11 103419 RK	R-7,200	Residential 7,200 sq. ft.	SFR-Basic
11 103996 RK	R-7,200	Residential 7,200 sq. ft.	SFR-Basic
11 104339 RK	R-7,200	Residential 7,200 sq. ft.	SFR-Basic
11 104340 RK	R-7,200	Residential 7,200 sq. ft.	SFR-Basic
11 103997 RK	R-7,200	Residential 7,200 sq. ft.	SFR-Basic
11 104338 RK	R-7,200	Residential 7,200 sq. ft.	SFR-Basic
11 101428 RK	R-7,200	Residential 7,200 sq. ft.	SFR-Basic
11 101429 RK	R-7,200	Residential 7,200 sq. ft.	SFR-Basic
10 109347 RK	R-5	Rural-5 Acre	Single Family Residential
11 105361 RK	R-7,200	Residential 7,200 sq. ft.	SFR-Basic
11 105362 RK	R-7,200	Residential 7,200 sq. ft.	SFR-Basic
11 105638 RK	R-7,200	Residential 7,200 sq. ft.	SFR-Basic
11 105639 RK	R-7,200	Residential 7,200 sq. ft.	SFR-Basic
11 105640 RK	R-7,200	Residential 7,200 sq. ft.	SFR-Basic
11 105725 RK	R-7,200	Residential 7,200 sq. ft.	SFR-Basic
11 106302 RK	R-7,200	Residential 7,200 sq. ft.	SFR-Basic
11 105726 RK	R-7,200	Residential 7,200 sq. ft.	SFR-Basic
11 107217 RK	R-7,200	Residential 7,200 sq. ft.	SFR-Basic
11 107218 RK	R-7,200	Residential 7,200 sq. ft.	SFR-Basic
10 106696 RK	R-5	Rural-5 Acre	SFR-Basic
10 109498 RK	R-7,200(PRD)	Residential 7,200 sq. ft.	Duplex-Basic
10 109499 RK	R-7,200(PRD)	Residential 7,200 sq. ft.	Duplex-Basic
10 109500 RK	R-7,200(PRD)	Residential 7,200 sq. ft.	Duplex-Basic
10 109493 RK	R-7,200(PRD)	Residential 7,200 sq. ft.	SFR-Basic
10 109494 RK	R-7,200(PRD)	Residential 7,200 sq. ft.	SFR-Basic
10 109495 RK	R-7,200(PRD)	Residential 7,200 sq. ft.	SFR-Basic
10 109496 RK	R-7,200(PRD)	Residential 7,200 sq. ft.	SFR-Basic
10 109497 RK	R-7,200(PRD)	Residential 7,200 sq. ft.	SFR-Basic
11 102034 RK	R-5	Rural-5 Acre	Single Family Residential
11 100154 RK	R-5	Rural-5 Acre	Single Family Residential



Accessory Dwelling Units

Index # - File Name: 1.0022 - Single Family Dwellings Data\_Snohomish County.pdf

11 100476 RK	R-9,600	Residential 9,600 sq. ft.	Single Family Residential
11 102498 RK	MR	Multiple Residential	Single Family Residential
10 104935 RK	LDMR	Low Density Multiple Reside	SFR-Basic
11 104286 000 01 RK	R-8,400	Residential 8,400 sq. ft.	Duplex
11 100400 RK	MR	Multiple Residential	SFR-Basic
11 104392 RK	R-9,600	Residential 9,600 sq. ft.	SFR-Basic
11 104393 RK	R-9,600	Residential 9,600 sq. ft.	SFR-Basic
11 104394 RK	R-9,600	Residential 9,600 sq. ft.	SFR-Basic
11 105581 RK	R-9,600	Residential 9,600 sq. ft.	SFR-Basic
11 105582 RK	R-9,600	Residential 9,600 sq. ft.	SFR-Basic
11 106303 RK	R-9,600	Residential 9,600 sq. ft.	SFR-Basic
11 108001 RK	R-9,600	Residential 9,600 sq. ft.	SFR-Basic
11 108002 RK	R-9,600	Residential 9,600 sq. ft.	SFR-Basic
11 108003 RK	R-9,600	Residential 9,600 sq. ft.	SFR-Basic
11 109707 RK	R-9,600	Residential 9,600 sq. ft.	SFR-Basic
11 109708 RK	R-9,600	Residential 9,600 sq. ft.	SFR-Basic
11 109709 RK	R-9,600	Residential 9,600 sq. ft.	SFR-Basic
11 109710 RK	R-9,600	Residential 9,600 sq. ft.	SFR-Basic
11 106977 RK	R-9,600	Residential 9,600 sq. ft.	SFR-Basic
11 108409 RK	R-9,600	Residential 9,600 sq. ft.	SFR-Basic
11 109711 RK	R-9,600	Residential 9,600 sq. ft.	SFR-Basic
11 109712 RK	R-9,600	Residential 9,600 sq. ft.	SFR-Basic
11 109713 RK	R-9,600	Residential 9,600 sq. ft.	SFR-Basic
11 109714 RK	R-9,600	Residential 9,600 sq. ft.	SFR-Basic
11 108004 RK	R-9,600	Residential 9,600 sq. ft.	SFR-Basic
11 108005 RK	R-9,600	Residential 9,600 sq. ft.	SFR-Basic
11 108006 RK	R-9,600	Residential 9,600 sq. ft.	SFR-Basic
11 104395 RK	R-9,600	Residential 9,600 sq. ft.	SFR-Basic
11 104396 RK	R-9,600	Residential 9,600 sq. ft.	SFR-Basic
11 104397 RK	R-9,600	Residential 9,600 sq. ft.	SFR-Basic
11 106304 RK	R-9,600	Residential 9,600 sq. ft.	SFR-Basic
11 106305 RK	R-9,600	Residential 9,600 sq. ft.	SFR-Basic
11 106306 RK	R-9,600	Residential 9,600 sq. ft.	SFR-Basic
11 105727 RK	R-7,200	Residential 7,200 sq. ft.	SFR-Basic
11 105641 RK	R-7,200	Residential 7,200 sq. ft.	SFR-Basic
11 104196 RK	R-7,200	Residential 7,200 sq. ft.	SFR-Basic
11 104197 RK	R-7,200	Residential 7,200 sq. ft.	SFR-Basic
11 104198 RK	R-7,200	Residential 7,200 sq. ft.	SFR-Basic
11 104199 RK	R-7,200	Residential 7,200 sq. ft.	SFR-Basic
11 104200 RK	R-7,200	Residential 7,200 sq. ft.	SFR-Basic
11 103748 RK	R-7,200	Residential 7,200 sq. ft.	SFR-Basic
11 104823 RK	R-7,200	Residential 7,200 sq. ft.	SFR-Basic
10 109381 RK	R-7,200	Residential 7,200 sq. ft.	SFR-Basic
10 109382 RK	R-7,200	Residential 7,200 sq. ft.	SFR-Basic
10 109384 RK	R-7,200	Residential 7,200 sq. ft.	SFR-Basic
10 109385 RK	R-7,200	Residential 7,200 sq. ft.	SFR-Basic
10 109386 RK	R-7,200	Residential 7,200 sq. ft.	SFR-Basic

Accessory Dwelling Units

Index # - File Name: 1.0022 - Single Family Dwellings Data\_Snohomish County.pdf

10 109387 RK	R-7,200	Residential 7,200 sq. ft.	SFR-Basic
10 109568 RK	R-7,200	Residential 7,200 sq. ft.	SFR-Basic
10 109388 RK	R-7,200	Residential 7,200 sq. ft.	SFR-Basic
10 109389 RK	R-7,200	Residential 7,200 sq. ft.	SFR-Basic
10 109390 RK	R-7,200	Residential 7,200 sq. ft.	SFR-Basic
10 109391 RK	R-7,200	Residential 7,200 sq. ft.	SFR-Basic
10 109569 RK	R-7,200	Residential 7,200 sq. ft.	SFR-Basic
11 107830 RK	R-9,600	Residential 9,600 sq. ft.	SFR-Basic
11 108403 RK	R-7,200	Residential 7,200 sq. ft.	SFR-Basic
11 106056 RK	R-7,200	Residential 7,200 sq. ft.	SFR-Basic
11 100651 MH	R-5	Rural-5 Acre	Double Wide
11 101101 RK	CITY	City	SFR-Basic
11 101102 RK	CITY	City	SFR-Basic
11 101103 RK	CITY	City	SFR-Basic
11 101104 RK	CITY	City	SFR-Basic
11 101105 RK	CITY	City	SFR-Basic
11 101106 RK	CITY	City	SFR-Basic
11 101107 RK	CITY	City	SFR-Basic
11 106818 RK	CITY	City	SFR-Basic
11 106819 RK	CITY	City	SFR-Basic
11 106820 RK	CITY	City	SFR-Basic
11 106821 RK	CITY	City	SFR-Basic
11 106822 RK	CITY	City	SFR-Basic
11 106823 RK	CITY	City	SFR-Basic
11 108027 RK	CITY	City	SFR-Basic
11 108028 RK	CITY	City	SFR-Basic
11 101099 RK	CITY	City	SFR-Basic
11 101100 RK	CITY	City	SFR-Basic
11 105728 RK	CITY	City	SFR-Basic
11 105729 RK	CITY	City	SFR-Basic
11 104996 RK	CITY	City	SFR-Basic
11 104997 RK	CITY	City	SFR-Basic
11 104998 RK	CITY	City	SFR-Basic
11 104999 RK	CITY	City	SFR-Basic
11 103505 RK	CITY	City	SFR-Basic
11 103506 RK	CITY	City	SFR-Basic
11 103507 RK	CITY	City	SFR-Basic
11 103508 RK	CITY	City	SFR-Basic
11 103509 RK	CITY	City	SFR-Basic
11 109368 RK	R-7,200	Residential 7,200 sq. ft.	SFR-Basic
11 108451 RK	R-7,200	Residential 7,200 sq. ft.	SFR-Basic
11 100760 RK	R-5	Rural-5 Acre	Single Family Residential
11 101098 RK	CITY	City	SFR-Basic
11 103054 RK	R-7,200	Residential 7,200 sq. ft.	SFR-Basic
11 108061 RK	R-7,200	Residential 7,200 sq. ft.	SFR-Basic
11 108062 RK	R-7,200	Residential 7,200 sq. ft.	SFR-Basic
11 107219 RK	R-7,200	Residential 7,200 sq. ft.	SFR-Basic

Accessory Dwelling Units

Index # - File Name: 1.0022 - Single Family Dwellings Data\_Snohomish County.pdf

11 107220 RK	R-7,200	Residential 7,200 sq. ft.	SFR-Basic
11 109369 RK	R-7,200	Residential 7,200 sq. ft.	SFR-Basic
11 109677 RK	R-7,200	Residential 7,200 sq. ft.	SFR-Basic
11 106399 RK	R-7,200	Residential 7,200 sq. ft.	SFR-Basic
11 106397 RK	R-7,200	Residential 7,200 sq. ft.	SFR-Basic
11 101535 RK	R-5	Rural-5 Acre	Single Family Residential
11 101710 RK	R-7,200	Residential 7,200 sq. ft.	SFR-Basic
11 101711 RK	R-7,200	Residential 7,200 sq. ft.	SFR-Basic
11 101712 RK	R-7,200	Residential 7,200 sq. ft.	SFR-Basic
11 101713 RK	R-7,200	Residential 7,200 sq. ft.	SFR-Basic
11 101748 RK	R-5	Rural-5 Acre	Single Family Residential
11 105741 RK	R-5	Rural-5 Acre	Single Family Residential
11 101993 RK	RC	Rural Conservation	Single Family Residential
11 106400 RK	R-7,200	Residential 7,200 sq. ft.	SFR-Basic
11 106398 RK	R-7,200	Residential 7,200 sq. ft.	SFR-Basic
11 107846 RK	R-7,200	Residential 7,200 sq. ft.	SFR-Basic
11 105427 RK	R-7,200	Residential 7,200 sq. ft.	SFR-Basic
11 105428 RK	R-7,200	Residential 7,200 sq. ft.	SFR-Basic
11 105425 RK	R-7,200	Residential 7,200 sq. ft.	SFR-Basic
11 105426 RK	R-7,200	Residential 7,200 sq. ft.	SFR-Basic
11 105429 RK	R-7,200	Residential 7,200 sq. ft.	SFR-Basic
11 103258 RK	R-7,200	Residential 7,200 sq. ft.	SFR-Basic
11 108985 RK	R-7,200	Residential 7,200 sq. ft.	SFR-Basic
11 109818 RK	R-7,200	Residential 7,200 sq. ft.	SFR-Basic
11 108739 RK	R-7,200	Residential 7,200 sq. ft.	SFR-Basic
11 107847 RK	R-7,200	Residential 7,200 sq. ft.	SFR-Basic
11 107848 RK	R-7,200	Residential 7,200 sq. ft.	SFR-Basic
11 107849 RK	R-7,200	Residential 7,200 sq. ft.	SFR-Basic
11 108738 RK	R-7,200	Residential 7,200 sq. ft.	SFR-Basic
10 108591 RK	R-7,200(PRD)	Residential 7,200 sq. ft.	SFR-Basic
10 108592 RK	R-7,200(PRD)	Residential 7,200 sq. ft.	SFR-Basic
10 108593 RK	R-7,200(PRD)	Residential 7,200 sq. ft.	SFR-Basic
10 108202 RK	R-7,200(PRD)	Residential 7,200 sq. ft.	SFR-Basic
10 104370 RK	R-7,200(PRD)	Residential 7,200 sq. ft.	SFR-Basic
10 104368 RK	R-7,200(PRD)	Residential 7,200 sq. ft.	SFR-Basic
10 109121 RK	R-7,200(PRD)	Residential 7,200 sq. ft.	SFR-Basic
10 109122 RK	R-7,200(PRD)	Residential 7,200 sq. ft.	SFR-Basic
10 109123 RK	R-7,200(PRD)	Residential 7,200 sq. ft.	SFR-Basic
10 109124 RK	R-7,200(PRD)	Residential 7,200 sq. ft.	SFR-Basic
10 104375 RK	R-7,200(PRD)	Residential 7,200 sq. ft.	SFR-Basic
10 109307 RK	R-7,200	Residential 7,200 sq. ft.	SFR-Basic
10 109308 RK	R-7,200	Residential 7,200 sq. ft.	SFR-Basic
11 103155 RK	R-7,200	Residential 7,200 sq. ft.	Single Family Residential
11 103156 RK	R-7,200	Residential 7,200 sq. ft.	Single Family Residential
10 106695 RK	R-5	Rural-5 Acre	SFR-Basic
09 106770 000 01 RK	R-5	Rural-5 Acre	Single Family Residential
10 108111 RK	R-7,200	Residential 7,200 sq. ft.	SFR-Basic

Accessory Dwelling Units

Index # - File Name: 1.0022 - Single Family Dwellings Data\_Snohomish County.pdf

10 108112 RK	R-7,200	Residential 7,200 sq. ft.	SFR-Basic
10 104938 RK	LDMR	Low Density Multiple Reside	SFR-Basic
10 104942 RK	LDMR	Low Density Multiple Reside	SFR-Basic
10 104943 RK	LDMR	Low Density Multiple Reside	SFR-Basic
10 104681 RK			Single Family Residential
10 101610 MH	R-5	Rural-5 Acre	Double Wide
11 104195 RK	R-7,200	Residential 7,200 sq. ft.	SFR-Basic
11 100404 RK	R-7,200	Residential 7,200 sq. ft.	SFR-Basic
11 100056 RK	R-7,200	Residential 7,200 sq. ft.	SFR-Basic
11 100057 RK	R-7,200	Residential 7,200 sq. ft.	SFR-Basic
10 109231 RK	R-7,200	Residential 7,200 sq. ft.	SFR-Basic
10 109232 RK	R-7,200	Residential 7,200 sq. ft.	SFR-Basic
11 102919 RK	R-7,200	Residential 7,200 sq. ft.	SFR-Basic
11 101989 RK	R-7,200	Residential 7,200 sq. ft.	SFR-Basic
11 101990 RK	R-7,200	Residential 7,200 sq. ft.	SFR-Basic
10 109226 RK	R-7,200	Residential 7,200 sq. ft.	SFR-Basic
10 109227 RK	R-7,200	Residential 7,200 sq. ft.	SFR-Basic
10 109229 RK	R-7,200	Residential 7,200 sq. ft.	SFR-Basic
10 109230 RK	R-7,200	Residential 7,200 sq. ft.	SFR-Basic
11 101991 RK	R-7,200	Residential 7,200 sq. ft.	SFR-Basic
11 101635 RK	R-7,200	Residential 7,200 sq. ft.	SFR-Basic
11 100793 RK	R-7,200	Residential 7,200 sq. ft.	SFR-Basic
11 102269 RK	R-7,200	Residential 7,200 sq. ft.	SFR-Basic
11 103749 RK	R-7,200	Residential 7,200 sq. ft.	SFR-Basic
11 108007 RK	R-7,200	Residential 7,200 sq. ft.	SFR-Basic
11 108008 RK	R-7,200	Residential 7,200 sq. ft.	SFR-Basic
10 104378 RK	R-7,200(PRD)	Residential 7,200 sq. ft.	SFR-Basic
11 104946 RK	R-7,200(PRD)	Residential 7,200 sq. ft.	SFR-Basic
10 104379 RK	R-7,200(PRD)	Residential 7,200 sq. ft.	SFR-Basic
11 105930 RK	R-7,200(PRD)	Residential 7,200 sq. ft.	SFR-Basic
11 105931 RK	R-7,200(PRD)	Residential 7,200 sq. ft.	SFR-Basic
10 104380 RK	R-7,200(PRD)	Residential 7,200 sq. ft.	SFR-Basic
11 100676 RK	R-7,200(PRD)	Residential 7,200 sq. ft.	SFR-Basic
10 104381 RK	R-7,200(PRD)	Residential 7,200 sq. ft.	SFR-Basic
10 104377 RK	R-7,200(PRD)	Residential 7,200 sq. ft.	SFR-Basic
11 105926 RK	R-7,200(PRD)	Residential 7,200 sq. ft.	SFR-Basic
11 107024 RK	R-7,200(PRD)	Residential 7,200 sq. ft.	SFR-Basic
11 105927 RK	R-7,200(PRD)	Residential 7,200 sq. ft.	SFR-Basic
11 105928 RK	R-7,200(PRD)	Residential 7,200 sq. ft.	SFR-Basic
11 105929 RK	R-7,200(PRD)	Residential 7,200 sq. ft.	SFR-Basic
11 107273 RK	R-7,200(PRD)	Residential 7,200 sq. ft.	SFR-Basic
11 107270 RK	R-7,200(PRD)	Residential 7,200 sq. ft.	SFR-Basic
11 107274 RK	R-7,200(PRD)	Residential 7,200 sq. ft.	SFR-Basic
11 107271 RK	R-7,200(PRD)	Residential 7,200 sq. ft.	SFR-Basic
11 107465 RK	R-7,200(PRD)	Residential 7,200 sq. ft.	SFR-Basic
11 107275 RK	R-7,200(PRD)	Residential 7,200 sq. ft.	SFR-Basic
11 107276 RK	R-7,200(PRD)	Residential 7,200 sq. ft.	SFR-Basic

Accessory Dwelling Units

Index # - File Name: 1.0022 - Single Family Dwellings Data\_Snohomish County.pdf

10 109118 RK	R-7,200(PRD)	Residential 7,200 sq. ft.	SFR-Basic
10 109119 RK	R-7,200(PRD)	Residential 7,200 sq. ft.	SFR-Basic
10 109120 RK	R-7,200(PRD)	Residential 7,200 sq. ft.	SFR-Basic
10 109130 RK	R-7,200(PRD)	Residential 7,200 sq. ft.	SFR-Basic
10 109131 RK	R-7,200(PRD)	Residential 7,200 sq. ft.	SFR-Basic
11 105248 RK	R-5	Rural-5 Acre	Single Family Residential
10 104730 RK	R-5	Rural-5 Acre	Single Family Residential
10 104734 RK	R-5	Rural-5 Acre	SFR-Basic
10 104733 RK	R-5	Rural-5 Acre	Single Family Residential
11 102402 000 01 RK	A-10	Agriculture-10 Acre	Single Family Residential
11 105629 RK	R-7,200(PRD)	Residential 7,200 sq. ft.	SFR-Basic
11 105633 RK	R-7,200(PRD)	Residential 7,200 sq. ft.	SFR-Basic
11 105634 RK	R-7,200(PRD)	Residential 7,200 sq. ft.	SFR-Basic
11 104001 RK	R-7,200(PRD)	Residential 7,200 sq. ft.	SFR-Basic
11 104002 RK	R-7,200(PRD)	Residential 7,200 sq. ft.	SFR-Basic
11 103046 RK	R-7,200(PRD)	Residential 7,200 sq. ft.	SFR-Basic
11 103047 RK	R-7,200(PRD)	Residential 7,200 sq. ft.	SFR-Basic
11 103048 RK	R-7,200(PRD)	Residential 7,200 sq. ft.	SFR-Basic
11 105630 RK	R-7,200(PRD)	Residential 7,200 sq. ft.	SFR-Basic
11 105631 RK	R-7,200(PRD)	Residential 7,200 sq. ft.	SFR-Basic
11 105632 RK	R-7,200(PRD)	Residential 7,200 sq. ft.	SFR-Basic
11 108201 RK	R-7,200(PRD)	Residential 7,200 sq. ft.	SFR-Basic
11 108202 RK	R-7,200(PRD)	Residential 7,200 sq. ft.	SFR-Basic
11 107782 RK	R-7,200(PRD)	Residential 7,200 sq. ft.	SFR-Basic
11 109392 RK	R-7,200(PRD)	Residential 7,200 sq. ft.	SFR-Basic
11 108871 RK	R-7,200(PRD)	Residential 7,200 sq. ft.	SFR-Basic
11 109393 RK	R-7,200(PRD)	Residential 7,200 sq. ft.	SFR-Basic
11 108016 RK	R-7,200(PRD)	Residential 7,200 sq. ft.	SFR-Basic
11 107191 RK	R-7,200(PRD)	Residential 7,200 sq. ft.	SFR-Basic
11 107192 RK	R-7,200(PRD)	Residential 7,200 sq. ft.	SFR-Basic
11 107193 RK	R-7,200(PRD)	Residential 7,200 sq. ft.	SFR-Basic
11 107194 RK	R-7,200(PRD)	Residential 7,200 sq. ft.	SFR-Basic
11 107195 RK	R-7,200(PRD)	Residential 7,200 sq. ft.	SFR-Basic
11 107196 RK	R-7,200(PRD)	Residential 7,200 sq. ft.	SFR-Basic
11 107197 RK	R-7,200(PRD)	Residential 7,200 sq. ft.	SFR-Basic
11 107198 RK	R-7,200(PRD)	Residential 7,200 sq. ft.	SFR-Basic
11 107199 RK	R-7,200(PRD)	Residential 7,200 sq. ft.	SFR-Basic
11 105610 RK	R-7,200(PRD)	Residential 7,200 sq. ft.	SFR-Basic
11 105611 RK	R-7,200(PRD)	Residential 7,200 sq. ft.	SFR-Basic
11 105612 RK	R-7,200(PRD)	Residential 7,200 sq. ft.	SFR-Basic
11 105613 RK	R-7,200(PRD)	Residential 7,200 sq. ft.	SFR-Basic
11 105614 RK	R-7,200(PRD)	Residential 7,200 sq. ft.	SFR-Basic
11 105615 RK	R-7,200(PRD)	Residential 7,200 sq. ft.	SFR-Basic
11 105616 RK	R-7,200(PRD)	Residential 7,200 sq. ft.	SFR-Basic
11 105617 RK	R-7,200(PRD)	Residential 7,200 sq. ft.	SFR-Basic
11 105618 RK	R-7,200(PRD)	Residential 7,200 sq. ft.	SFR-Basic
11 105619 RK	R-7,200(PRD)	Residential 7,200 sq. ft.	SFR-Basic

Accessory Dwelling Units

Index # - File Name: 1.0022 - Single Family Dwellings Data\_Snohomish County.pdf

11 105620 RK	R-7,200(PRD)	Residential 7,200 sq. ft.	SFR-Basic
11 105621 RK	R-7,200(PRD)	Residential 7,200 sq. ft.	SFR-Basic
11 105622 RK	R-7,200(PRD)	Residential 7,200 sq. ft.	SFR-Basic
11 105623 RK	R-7,200(PRD)	Residential 7,200 sq. ft.	SFR-Basic
11 107200 RK	R-7,200(PRD)	Residential 7,200 sq. ft.	SFR-Basic
11 107201 RK	R-7,200(PRD)	Residential 7,200 sq. ft.	SFR-Basic
11 107202 RK	R-7,200(PRD)	Residential 7,200 sq. ft.	SFR-Basic
11 107203 RK	R-7,200(PRD)	Residential 7,200 sq. ft.	SFR-Basic
11 107204 RK	R-7,200(PRD)	Residential 7,200 sq. ft.	SFR-Basic
11 107205 RK	R-7,200(PRD)	Residential 7,200 sq. ft.	SFR-Basic
11 108020 RK	R-7,200(PRD)	Residential 7,200 sq. ft.	SFR-Basic
11 108021 RK	R-7,200(PRD)	Residential 7,200 sq. ft.	SFR-Basic
11 105635 RK	R-7,200(PRD)	Residential 7,200 sq. ft.	SFR-Basic
11 105636 RK	R-7,200(PRD)	Residential 7,200 sq. ft.	SFR-Basic
11 108405 RK	R-7,200(PRD)	Residential 7,200 sq. ft.	SFR-Basic
11 108018 RK	R-7,200(PRD)	Residential 7,200 sq. ft.	SFR-Basic
11 105637 RK	R-7,200(PRD)	Residential 7,200 sq. ft.	SFR-Basic
11 104150 RK	R-7,200	Residential 7,200 sq. ft.	Duplex
11 108404 RK	R-7,200(PRD)	Residential 7,200 sq. ft.	SFR-Basic
11 104878 RK	R-9,600	Residential 9,600 sq. ft.	Single Family Residential
11 105142 RK	R-9,600	Residential 9,600 sq. ft.	Single Family Residential
11 108777 RK	R-7,200(PRD)	Residential 7,200 sq. ft.	SFR-Basic
11 108778 RK	R-7,200(PRD)	Residential 7,200 sq. ft.	SFR-Basic
11 107797 RK	R-7,200(PRD)	Residential 7,200 sq. ft.	SFR-Basic
11 108825 RK	R-7,200(PRD)	Residential 7,200 sq. ft.	Single Family Residential
11 107788 RK	R-7,200(PRD)	Residential 7,200 sq. ft.	SFR-Basic
11 107789 RK	R-7,200(PRD)	Residential 7,200 sq. ft.	SFR-Basic
11 107790 RK	R-7,200(PRD)	Residential 7,200 sq. ft.	SFR-Basic
11 107791 RK	R-7,200(PRD)	Residential 7,200 sq. ft.	SFR-Basic
11 107792 RK	R-7,200(PRD)	Residential 7,200 sq. ft.	SFR-Basic
11 107793 RK	R-7,200(PRD)	Residential 7,200 sq. ft.	SFR-Basic
11 107794 RK	R-7,200(PRD)	Residential 7,200 sq. ft.	SFR-Basic
11 107796 RK	R-7,200(PRD)	Residential 7,200 sq. ft.	SFR-Basic
11 108772 RK	R-7,200(PRD)	Residential 7,200 sq. ft.	SFR-Basic
11 108773 RK	R-7,200(PRD)	Residential 7,200 sq. ft.	SFR-Basic
11 105905 MH	R-12,500	Residential 12,500 sq. ft.	Double Wide
11 106613 RK	R-5	Rural-5 Acre	Single Family Residential
11 105688 000 01 RK	R-5	Rural-5 Acre	Single Family Residential
11 106318 RK	R-9,600	Residential 9,600 sq. ft.	SFR-Basic
11 107566 RK	LDMR	Low Density Multiple Reside	SFR-Basic
11 107561 RK	LDMR	Low Density Multiple Reside	SFR-Basic
11 107563 RK	LDMR	Low Density Multiple Reside	SFR-Basic
11 107565 RK	LDMR	Low Density Multiple Reside	SFR-Basic
11 107559 RK	LDMR	Low Density Multiple Reside	SFR-Basic
11 107554 RK	LDMR	Low Density Multiple Reside	SFR-Basic
11 107671 RK	R-5	Rural-5 Acre	Single Family Residential
11 107673 RK	R-5	Rural-5 Acre	SFR-Basic

Accessory Dwelling Units

Index # - File Name: 1.0022 - Single Family Dwellings Data\_Snohomish County.pdf

11 107762 RK	R-7,200	Residential 7,200 sq. ft.	Duplex-Basic
11 109135 RK	R-5	Rural-5 Acre	Single Family Residential
12 104363 RK	R-5	Rural-5 Acre	Single Family Residential
12 100098 RK	LDMR	Low Density Multiple Reside	SFR-Basic
12 110326 RK	R-7,200	Residential 7,200 sq. ft.	SFR-Basic
12 103690 RK	R-7,200	Residential 7,200 sq. ft.	SFR-Basic
12 101745 RK	R-7,200	Residential 7,200 sq. ft.	SFR-Basic
12 105706 RK	R-7,200	Residential 7,200 sq. ft.	SFR-Basic
12 105707 RK	R-7,200	Residential 7,200 sq. ft.	SFR-Basic
12 102067 RK	R-7,200	Residential 7,200 sq. ft.	SFR-Basic
12 102059 RK	R-7,200	Residential 7,200 sq. ft.	SFR-Basic
12 102060 RK	R-7,200	Residential 7,200 sq. ft.	SFR-Basic
12 102068 RK	R-7,200	Residential 7,200 sq. ft.	SFR-Basic
12 106002 RK	R-7,200	Residential 7,200 sq. ft.	SFR-Basic
12 106003 RK	R-7,200	Residential 7,200 sq. ft.	SFR-Basic
12 108335 RK	R-7,200	Residential 7,200 sq. ft.	SFR-Basic
12 100936 RK	R-7,200	Residential 7,200 sq. ft.	SFR-Basic
12 100087 RK	R-7,200	Residential 7,200 sq. ft.	SFR-Basic
12 106000 RK	R-7,200	Residential 7,200 sq. ft.	SFR-Basic
12 106001 RK	R-7,200	Residential 7,200 sq. ft.	SFR-Basic
12 100382 RK	R-7,200	Residential 7,200 sq. ft.	SFR-Basic
12 100004 RK	R-7,200	Residential 7,200 sq. ft.	SFR-Basic
12 100005 RK	R-7,200	Residential 7,200 sq. ft.	SFR-Basic
12 105504 RK	R-7,200	Residential 7,200 sq. ft.	Single Family Residential
12 108334 RK	R-7,200	Residential 7,200 sq. ft.	SFR-Basic
12 109449 RK	R-7,200	Residential 7,200 sq. ft.	SFR-Basic
12 109451 RK	R-7,200	Residential 7,200 sq. ft.	SFR-Basic
12 109694 RK	R-7,200	Residential 7,200 sq. ft.	SFR-Basic
12 105258 RK	R-7,200	Residential 7,200 sq. ft.	SFR-Basic
12 104374 RK	R-7,200	Residential 7,200 sq. ft.	SFR-Basic
12 103325 RK	R-7,200	Residential 7,200 sq. ft.	SFR-Basic
12 105797 RK	R-7,200	Residential 7,200 sq. ft.	SFR-Basic
12 107197 RK	R-7,200	Residential 7,200 sq. ft.	SFR-Basic
12 105259 RK	R-7,200	Residential 7,200 sq. ft.	SFR-Basic
12 104375 RK	R-7,200	Residential 7,200 sq. ft.	SFR-Basic
12 105705 RK	R-7,200	Residential 7,200 sq. ft.	SFR-Basic
12 100503 RK	R-7,200	Residential 7,200 sq. ft.	SFR-Basic
12 100505 RK	R-7,200	Residential 7,200 sq. ft.	SFR-Basic
12 110327 RK	R-7,200	Residential 7,200 sq. ft.	SFR-Basic
12 105505 RK	R-7,200	Residential 7,200 sq. ft.	SFR-Basic
12 109452 RK	R-7,200	Residential 7,200 sq. ft.	SFR-Basic
12 109453 RK	R-7,200	Residential 7,200 sq. ft.	SFR-Basic
12 103326 RK	R-7,200	Residential 7,200 sq. ft.	SFR-Basic
12 103327 RK	R-7,200	Residential 7,200 sq. ft.	SFR-Basic
12 106004 RK	R-7,200	Residential 7,200 sq. ft.	SFR-Basic
12 106005 RK	R-7,200	Residential 7,200 sq. ft.	SFR-Basic
12 104376 RK	R-7,200	Residential 7,200 sq. ft.	SFR-Basic

Accessory Dwelling Units

Index # - File Name: 1.0022 - Single Family Dwellings Data\_Snohomish County.pdf

12 105708 RK	R-7,200	Residential 7,200 sq. ft.	SFR-Basic
12 104905 RK	R-9,600	Residential 9,600 sq. ft.	Single Family Residential
12 105457 RK	R-9,600	Residential 9,600 sq. ft.	Single Family Residential
12 106408 RK	R-9,600	Residential 9,600 sq. ft.	Single Family Residential
12 104907 RK	R-9,600	Residential 9,600 sq. ft.	Single Family Residential
12 105068 RK	R-9,600	Residential 9,600 sq. ft.	Single Family Residential
12 104908 RK	R-9,600	Residential 9,600 sq. ft.	Single Family Residential
12 105069 RK	R-9,600	Residential 9,600 sq. ft.	Single Family Residential
12 101329 RK	R-9,600	Residential 9,600 sq. ft.	Single Family Residential
12 101116 RK	R-9,600	Residential 9,600 sq. ft.	Single Family Residential
12 103267 RK	R-9,600	Residential 9,600 sq. ft.	Single Family Residential
12 101119 RK	R-9,600	Residential 9,600 sq. ft.	Single Family Residential
12 101331 RK	R-9,600	Residential 9,600 sq. ft.	Single Family Residential
12 101118 RK	R-9,600	Residential 9,600 sq. ft.	Single Family Residential
12 102163 RK	R-9,600	Residential 9,600 sq. ft.	Single Family Residential
12 103268 RK	R-9,600	Residential 9,600 sq. ft.	Single Family Residential
12 101332 RK	R-9,600	Residential 9,600 sq. ft.	Single Family Residential
12 101117 RK	R-9,600	Residential 9,600 sq. ft.	Single Family Residential
12 102164 RK	R-9,600	Residential 9,600 sq. ft.	Single Family Residential
12 106570 RK	R-9,600	Residential 9,600 sq. ft.	Single Family Residential
12 102281 RK	R-7,200	Residential 7,200 sq. ft.	Single Family Residential
12 102282 RK	R-7,200	Residential 7,200 sq. ft.	Single Family Residential
12 101632 RK	R-7,200	Residential 7,200 sq. ft.	Single Family Residential
12 110341 RK	R-8,400	Residential 8,400 sq. ft.	SFR-Basic
12 110342 RK	R-8,400	Residential 8,400 sq. ft.	SFR-Basic
12 109289 RK	R-8,400	Residential 8,400 sq. ft.	SFR-Basic
12 109706 RK	R-8,400	Residential 8,400 sq. ft.	SFR-Basic
12 103041 RK	R-7,200	Residential 7,200 sq. ft.	SFR-Basic
11 107408 RK	RD	Rural Diversification	Single Family Residential
12 108672 RK	R-5	Rural-5 Acre	Single Family Residential
12 108644 RK	R-7,200	Residential 7,200 sq. ft.	SFR-Basic
12 109380 RK	R-7,200	Residential 7,200 sq. ft.	SFR-Basic
12 109381 RK	R-7,200	Residential 7,200 sq. ft.	SFR-Basic
12 108240 RK	R-8,400	Residential 8,400 sq. ft.	SFR-Basic
12 108239 RK	R-8,400	Residential 8,400 sq. ft.	SFR-Basic
12 107284 RK	R-8,400	Residential 8,400 sq. ft.	SFR-Basic
12 106519 RK	R-8,400	Residential 8,400 sq. ft.	SFR-Basic
12 101225 RK	R-8,400	Residential 8,400 sq. ft.	SFR-Basic
12 101239 RK	R-8,400	Residential 8,400 sq. ft.	Single Family Residential
12 101235 RK	R-8,400	Residential 8,400 sq. ft.	SFR-Basic
12 101238 RK	R-8,400	Residential 8,400 sq. ft.	SFR-Basic
12 103204 RK	R-8,400	Residential 8,400 sq. ft.	SFR-Basic
12 103205 RK	R-8,400	Residential 8,400 sq. ft.	SFR-Basic
12 103800 RK	R-8,400	Residential 8,400 sq. ft.	SFR-Basic
12 103801 RK	R-8,400	Residential 8,400 sq. ft.	SFR-Basic
12 107285 RK	R-8,400	Residential 8,400 sq. ft.	SFR-Basic
12 110669 RK	R-8,400	Residential 8,400 sq. ft.	SFR-Basic



Accessory Dwelling Units

Index # - File Name: 1.0022 - Single Family Dwellings Data\_Snohomish County.pdf

12 109298 RK	R-8,400	Residential 8,400 sq. ft.	SFR-Basic
12 109705 RK	R-8,400	Residential 8,400 sq. ft.	SFR-Basic
12 105015 RK	R-8,400	Residential 8,400 sq. ft.	SFR-Basic
12 105449 RK	R-8,400	Residential 8,400 sq. ft.	SFR-Basic
12 106463 RK	R-8,400	Residential 8,400 sq. ft.	SFR-Basic
12 105013 RK	R-8,400	Residential 8,400 sq. ft.	SFR-Basic
12 105014 RK	R-8,400	Residential 8,400 sq. ft.	SFR-Basic
12 103802 RK	R-8,400	Residential 8,400 sq. ft.	SFR-Basic
12 103803 RK	R-8,400	Residential 8,400 sq. ft.	SFR-Basic
12 102071 RK	R-8,400	Residential 8,400 sq. ft.	SFR-Basic
12 100300 RK	R-8,400	Residential 8,400 sq. ft.	SFR-Basic
12 105016 RK	R-8,400	Residential 8,400 sq. ft.	SFR-Basic
12 104518 RK	R-8,400	Residential 8,400 sq. ft.	SFR-Basic
12 100006 RK	R-7,200	Residential 7,200 sq. ft.	SFR-Basic
12 107582 RK	R-7,200(PRD)	Residential 7,200 sq. ft.	SFR-Basic
12 109639 RK	R-7,200(PRD)	Residential 7,200 sq. ft.	SFR-Basic
12 107585 RK	R-7,200(PRD)	Residential 7,200 sq. ft.	SFR-Basic
12 105260 RK	R-7,200(PRD)	Residential 7,200 sq. ft.	SFR-Basic
11 109371 RK	R-7,200(PRD)	Residential 7,200 sq. ft.	SFR-Basic
12 105261 RK	R-7,200(PRD)	Residential 7,200 sq. ft.	SFR-Basic
12 106162 RK	R-7,200(PRD)	Residential 7,200 sq. ft.	SFR-Basic
12 110225 RK	R-7,200(PRD)	Residential 7,200 sq. ft.	SFR-Basic
12 105262 RK	R-7,200(PRD)	Residential 7,200 sq. ft.	SFR-Basic
12 106163 RK	R-7,200(PRD)	Residential 7,200 sq. ft.	SFR-Basic
12 105263 RK	R-7,200(PRD)	Residential 7,200 sq. ft.	SFR-Basic
12 109640 RK	R-7,200(PRD)	Residential 7,200 sq. ft.	SFR-Basic
12 109641 RK	R-7,200(PRD)	Residential 7,200 sq. ft.	SFR-Basic
12 110402 RK	R-7,200(PRD)	Residential 7,200 sq. ft.	SFR-Basic
12 110403 RK	R-7,200(PRD)	Residential 7,200 sq. ft.	SFR-Basic
12 104254 RK	R-7,200(PRD)	Residential 7,200 sq. ft.	SFR-Basic
12 104255 RK	R-7,200(PRD)	Residential 7,200 sq. ft.	SFR-Basic
12 104256 RK	R-7,200(PRD)	Residential 7,200 sq. ft.	SFR-Basic
12 104257 RK	R-7,200(PRD)	Residential 7,200 sq. ft.	SFR-Basic
12 104258 RK	R-7,200(PRD)	Residential 7,200 sq. ft.	SFR-Basic
12 104259 RK	R-7,200(PRD)	Residential 7,200 sq. ft.	SFR-Basic
12 104260 RK	R-7,200(PRD)	Residential 7,200 sq. ft.	SFR-Basic
12 104261 RK	R-7,200(PRD)	Residential 7,200 sq. ft.	SFR-Basic
12 104262 RK	R-7,200(PRD)	Residential 7,200 sq. ft.	SFR-Basic
12 104263 RK	R-7,200(PRD)	Residential 7,200 sq. ft.	SFR-Basic
12 104264 RK	R-7,200(PRD)	Residential 7,200 sq. ft.	SFR-Basic
12 102899 RK	R-7,200(PRD)	Residential 7,200 sq. ft.	SFR-Basic
12 102900 RK	R-7,200(PRD)	Residential 7,200 sq. ft.	SFR-Basic
12 102901 RK	R-7,200(PRD)	Residential 7,200 sq. ft.	SFR-Basic
12 102902 RK	R-7,200(PRD)	Residential 7,200 sq. ft.	SFR-Basic
12 102903 RK	R-7,200(PRD)	Residential 7,200 sq. ft.	SFR-Basic
12 102035 RK	R-7,200(PRD)	Residential 7,200 sq. ft.	SFR-Basic
12 102036 RK	R-7,200(PRD)	Residential 7,200 sq. ft.	SFR-Basic

Accessory Dwelling Units

Index # - File Name: 1.0022 - Single Family Dwellings Data\_Snohomish County.pdf

12 102053 RK	R-7,200(PRD)	Residential 7,200 sq. ft.	SFR-Basic
12 102037 RK	R-7,200(PRD)	Residential 7,200 sq. ft.	SFR-Basic
12 102038 RK	R-7,200(PRD)	Residential 7,200 sq. ft.	SFR-Basic
12 102039 RK	R-7,200(PRD)	Residential 7,200 sq. ft.	SFR-Basic
12 102040 RK	R-7,200(PRD)	Residential 7,200 sq. ft.	SFR-Basic
12 102041 RK	R-7,200(PRD)	Residential 7,200 sq. ft.	SFR-Basic
12 102042 RK	R-7,200(PRD)	Residential 7,200 sq. ft.	SFR-Basic
12 101717 RK	R-7,200(PRD)	Residential 7,200 sq. ft.	SFR-Basic
12 101718 RK	R-7,200(PRD)	Residential 7,200 sq. ft.	SFR-Basic
12 101719 RK	R-7,200(PRD)	Residential 7,200 sq. ft.	SFR-Basic
12 102043 RK	R-7,200(PRD)	Residential 7,200 sq. ft.	SFR-Basic
12 102044 RK	R-7,200(PRD)	Residential 7,200 sq. ft.	SFR-Basic
12 102045 RK	R-7,200(PRD)	Residential 7,200 sq. ft.	SFR-Basic
12 102046 RK	R-7,200(PRD)	Residential 7,200 sq. ft.	SFR-Basic
12 102047 RK	R-7,200(PRD)	Residential 7,200 sq. ft.	SFR-Basic
12 102904 RK	R-7,200(PRD)	Residential 7,200 sq. ft.	SFR-Basic
12 102905 RK	R-7,200(PRD)	Residential 7,200 sq. ft.	SFR-Basic
12 101720 RK	R-7,200(PRD)	Residential 7,200 sq. ft.	SFR-Basic
12 101721 RK	R-7,200(PRD)	Residential 7,200 sq. ft.	SFR-Basic
12 102048 RK	R-7,200(PRD)	Residential 7,200 sq. ft.	SFR-Basic
12 102049 RK	R-7,200(PRD)	Residential 7,200 sq. ft.	SFR-Basic
12 102050 RK	R-7,200(PRD)	Residential 7,200 sq. ft.	SFR-Basic
12 102906 RK	R-7,200(PRD)	Residential 7,200 sq. ft.	SFR-Basic
12 102907 RK	R-7,200(PRD)	Residential 7,200 sq. ft.	SFR-Basic
12 102908 RK	R-7,200(PRD)	Residential 7,200 sq. ft.	SFR-Basic
12 104265 RK	R-7,200(PRD)	Residential 7,200 sq. ft.	SFR-Basic
12 104266 RK	R-7,200(PRD)	Residential 7,200 sq. ft.	SFR-Basic
12 104267 RK	R-7,200(PRD)	Residential 7,200 sq. ft.	SFR-Basic
12 104268 RK	R-7,200(PRD)	Residential 7,200 sq. ft.	SFR-Basic
12 104269 RK	R-7,200(PRD)	Residential 7,200 sq. ft.	SFR-Basic
12 104270 RK	R-7,200(PRD)	Residential 7,200 sq. ft.	SFR-Basic
12 104271 RK	R-7,200(PRD)	Residential 7,200 sq. ft.	SFR-Basic
12 108708 RK	R-7,200(PRD)	Residential 7,200 sq. ft.	SFR-Basic
12 108709 RK	R-7,200(PRD)	Residential 7,200 sq. ft.	SFR-Basic
12 106724 RK	R-7,200(PRD)	Residential 7,200 sq. ft.	SFR-Basic
12 106725 RK	R-7,200(PRD)	Residential 7,200 sq. ft.	SFR-Basic
12 106726 RK	R-7,200(PRD)	Residential 7,200 sq. ft.	SFR-Basic
12 106727 RK	R-7,200(PRD)	Residential 7,200 sq. ft.	SFR-Basic
12 106728 RK	R-7,200(PRD)	Residential 7,200 sq. ft.	SFR-Basic
12 106729 RK	R-7,200(PRD)	Residential 7,200 sq. ft.	SFR-Basic
12 106730 RK	R-7,200(PRD)	Residential 7,200 sq. ft.	SFR-Basic
12 106731 RK	R-7,200(PRD)	Residential 7,200 sq. ft.	SFR-Basic
12 106732 RK	R-7,200(PRD)	Residential 7,200 sq. ft.	SFR-Basic
12 106733 RK	R-7,200(PRD)	Residential 7,200 sq. ft.	SFR-Basic
12 106734 RK	R-7,200(PRD)	Residential 7,200 sq. ft.	SFR-Basic
12 106735 RK	R-7,200(PRD)	Residential 7,200 sq. ft.	SFR-Basic
12 106736 RK	R-7,200(PRD)	Residential 7,200 sq. ft.	SFR-Basic

Accessory Dwelling Units

Index # - File Name: 1.0022 - Single Family Dwellings Data\_Snohomish County.pdf

12 106737 RK	R-7,200(PRD)	Residential 7,200 sq. ft.	SFR-Basic
12 106738 RK	R-7,200(PRD)	Residential 7,200 sq. ft.	SFR-Basic
12 108710 RK	R-7,200(PRD)	Residential 7,200 sq. ft.	SFR-Basic
12 108711 RK	R-7,200(PRD)	Residential 7,200 sq. ft.	SFR-Basic
12 105186 RK	R-7,200	Residential 7,200 sq. ft.	SFR-Basic
12 106158 RK	R-7,200	Residential 7,200 sq. ft.	SFR-Basic
12 106718 RK	R-7,200	Residential 7,200 sq. ft.	SFR-Basic
12 106159 RK	R-7,200	Residential 7,200 sq. ft.	SFR-Basic
12 106160 RK	R-7,200	Residential 7,200 sq. ft.	SFR-Basic
12 106471 RK	R-7,200	Residential 7,200 sq. ft.	Single Family Residential
12 106161 RK	R-7,200	Residential 7,200 sq. ft.	SFR-Basic
12 105187 RK	R-7,200	Residential 7,200 sq. ft.	SFR-Basic
12 103004 RK	R-7,200	Residential 7,200 sq. ft.	Single Family Residential
12 102383 RK	R-5	Rural-5 Acre	SFR-Basic
12 102426 RK	F	Forestry	SFR-Basic
12 100614 RK	R-7,200	Residential 7,200 sq. ft.	Single Family Residential
12 105442 RK	R-8,400	Residential 8,400 sq. ft.	Single Family Residential
12 101603 RK	R-5	Rural-5 Acre	Single Family Residential
12 100949 RK	R-5	Rural-5 Acre	Single Family Residential
12 100955 RK	LDMR	Low Density Multiple Reside	SFR-Basic
12 100956 RK	LDMR	Low Density Multiple Reside	SFR-Basic
12 100957 RK	LDMR	Low Density Multiple Reside	SFR-Basic
12 100958 RK	LDMR	Low Density Multiple Reside	SFR-Basic
12 104608 RK	LDMR	Low Density Multiple Reside	SFR-Basic
12 105196 RK	LDMR	Low Density Multiple Reside	SFR-Basic
12 106138 RK	LDMR	Low Density Multiple Reside	SFR-Basic
12 106139 RK	LDMR	Low Density Multiple Reside	SFR-Basic
12 106140 RK	LDMR	Low Density Multiple Reside	SFR-Basic
12 106008 RK	LDMR	Low Density Multiple Reside	SFR-Basic
12 104427 RK	LDMR	Low Density Multiple Reside	SFR-Basic
12 100864 RK	R-7,200(PRD)	Residential 7,200 sq. ft.	SFR-Basic
12 100865 RK	R-7,200(PRD)	Residential 7,200 sq. ft.	SFR-Basic
12 100394 RK	R-7,200(PRD)	Residential 7,200 sq. ft.	SFR-Basic
12 100395 RK	R-7,200(PRD)	Residential 7,200 sq. ft.	SFR-Basic
11 108774 RK	R-7,200(PRD)	Residential 7,200 sq. ft.	SFR-Basic
11 108775 RK	R-7,200(PRD)	Residential 7,200 sq. ft.	SFR-Basic
11 109628 RK	R-7,200(PRD)	Residential 7,200 sq. ft.	Single Family Residential
11 108776 RK	R-7,200(PRD)	Residential 7,200 sq. ft.	SFR-Basic
12 110383 RK	LDMR	Low Density Multiple Reside	SFR-Basic
12 108761 RK	LDMR	Low Density Multiple Reside	SFR-Basic
12 108762 RK	LDMR	Low Density Multiple Reside	SFR-Basic
12 108763 RK	LDMR	Low Density Multiple Reside	SFR-Basic
12 105193 RK	LDMR	Low Density Multiple Reside	SFR-Basic
12 105194 RK	LDMR	Low Density Multiple Reside	SFR-Basic
12 105195 RK	LDMR	Low Density Multiple Reside	SFR-Basic
12 102910 RK	LDMR	Low Density Multiple Reside	SFR-Basic
12 104606 RK	LDMR	Low Density Multiple Reside	SFR-Basic

Accessory Dwelling Units

Index # - File Name: 1.0022 - Single Family Dwellings Data\_Snohomish County.pdf

12 104607 RK	LDMR	Low Density Multiple Reside	SFR-Basic
12 103342 RK	LDMR	Low Density Multiple Reside	SFR-Basic
12 105997 RK	LDMR	Low Density Multiple Reside	SFR-Basic
12 105998 RK	LDMR	Low Density Multiple Reside	SFR-Basic
12 105999 RK	LDMR	Low Density Multiple Reside	SFR-Basic
12 100953 RK	LDMR	Low Density Multiple Reside	SFR-Basic
12 100954 RK	LDMR	Low Density Multiple Reside	SFR-Basic
12 105191 RK	LDMR	Low Density Multiple Reside	SFR-Basic
12 107871 RK	LDMR	Low Density Multiple Reside	SFR-Basic
12 105192 RK	LDMR	Low Density Multiple Reside	SFR-Basic
12 109397 RK	LDMR	Low Density Multiple Reside	SFR-Basic
12 109398 RK	LDMR	Low Density Multiple Reside	SFR-Basic
12 109882 RK	LDMR	Low Density Multiple Reside	SFR-Basic
12 109883 RK	LDMR	Low Density Multiple Reside	SFR-Basic
12 104426 RK	LDMR	Low Density Multiple Reside	SFR-Basic
12 107576 RK	LDMR	Low Density Multiple Reside	SFR-Basic
12 107577 RK	LDMR	Low Density Multiple Reside	SFR-Basic
12 110057 RK	R-7,200	Residential 7,200 sq. ft.	SFR-Basic
12 110060 RK	R-7,200	Residential 7,200 sq. ft.	SFR-Basic
12 110045 RK	R-7,200	Residential 7,200 sq. ft.	SFR-Basic
12 108646 RK	R-7,200	Residential 7,200 sq. ft.	SFR-Basic
12 108645 RK	R-7,200	Residential 7,200 sq. ft.	SFR-Basic
12 110059 RK	R-7,200	Residential 7,200 sq. ft.	SFR-Basic
12 109458 RK	R-7,200	Residential 7,200 sq. ft.	Single Family Residential
12 106049 RK	R-8,400	Residential 8,400 sq. ft.	SFR-Basic
12 109288 RK	R-8,400	Residential 8,400 sq. ft.	SFR-Basic
12 104617 RK	R-8,400	Residential 8,400 sq. ft.	SFR-Basic
12 104618 RK	R-8,400	Residential 8,400 sq. ft.	SFR-Basic
12 104619 RK	R-8,400	Residential 8,400 sq. ft.	SFR-Basic
12 104620 RK	R-8,400	Residential 8,400 sq. ft.	SFR-Basic
12 104516 RK	R-8,400	Residential 8,400 sq. ft.	SFR-Basic
12 104517 RK	R-8,400	Residential 8,400 sq. ft.	SFR-Basic
12 104821 RK	R-8,400	Residential 8,400 sq. ft.	SFR-Basic
12 108238 RK	R-8,400	Residential 8,400 sq. ft.	SFR-Basic
12 108719 RK	R-8,400	Residential 8,400 sq. ft.	SFR-Basic
12 109297 RK	R-8,400	Residential 8,400 sq. ft.	SFR-Basic
12 107283 RK	R-8,400	Residential 8,400 sq. ft.	SFR-Basic
12 101635 RK	R-8,400	Residential 8,400 sq. ft.	SFR-Basic
12 101224 RK	R-8,400	Residential 8,400 sq. ft.	SFR-Basic
11 108811 RK	R-7,200(PRD)	Residential 7,200 sq. ft.	Single Family Residential
12 100396 RK	R-7,200(PRD)	Residential 7,200 sq. ft.	SFR-Basic
12 100397 RK	R-7,200(PRD)	Residential 7,200 sq. ft.	SFR-Basic
12 100398 RK	R-7,200(PRD)	Residential 7,200 sq. ft.	SFR-Basic
12 100399 RK	R-7,200(PRD)	Residential 7,200 sq. ft.	SFR-Basic
11 109627 RK	R-7,200(PRD)	Residential 7,200 sq. ft.	Single Family Residential
11 108779 RK	R-7,200(PRD)	Residential 7,200 sq. ft.	SFR-Basic
11 108780 RK	R-7,200(PRD)	Residential 7,200 sq. ft.	SFR-Basic

Accessory Dwelling Units

Index # - File Name: 1.0022 - Single Family Dwellings Data\_Snohomish County.pdf

11 108781 RK	R-7,200(PRD)	Residential 7,200 sq. ft.	SFR-Basic
11 108782 RK	R-7,200(PRD)	Residential 7,200 sq. ft.	SFR-Basic
12 107469 RK	R-5	Rural-5 Acre	Single Family Residential
11 105011 RK	R-5	Rural-5 Acre	Single Family Residential
12 101935 RK	R-7,200(PRD)	Residential 7,200 sq. ft.	SFR-Basic
12 100256 RK	R-7,200(PRD)	Residential 7,200 sq. ft.	SFR-Basic
12 100257 RK	R-7,200(PRD)	Residential 7,200 sq. ft.	SFR-Basic
11 107206 RK	R-7,200(PRD)	Residential 7,200 sq. ft.	SFR-Basic
11 107207 RK	R-7,200(PRD)	Residential 7,200 sq. ft.	SFR-Basic
11 107208 RK	R-7,200(PRD)	Residential 7,200 sq. ft.	SFR-Basic
11 108838 RK	R-7,200(PRD)	Residential 7,200 sq. ft.	SFR-Basic
11 108839 RK	R-7,200(PRD)	Residential 7,200 sq. ft.	SFR-Basic
12 101153 RK	R-7,200(PRD)	Residential 7,200 sq. ft.	SFR-Basic
12 101154 RK	R-7,200(PRD)	Residential 7,200 sq. ft.	SFR-Basic
11 108841 RK	R-7,200(PRD)	Residential 7,200 sq. ft.	SFR-Basic
12 100603 RK	R-7,200(PRD)	Residential 7,200 sq. ft.	SFR-Basic
12 100604 RK	R-7,200(PRD)	Residential 7,200 sq. ft.	SFR-Basic
12 100605 RK	R-7,200(PRD)	Residential 7,200 sq. ft.	SFR-Basic
12 100606 RK	R-7,200(PRD)	Residential 7,200 sq. ft.	SFR-Basic
12 100607 RK	R-7,200(PRD)	Residential 7,200 sq. ft.	SFR-Basic
12 100608 RK	R-7,200(PRD)	Residential 7,200 sq. ft.	SFR-Basic
12 100255 RK	R-7,200(PRD)	Residential 7,200 sq. ft.	SFR-Basic
11 108827 RK	R-7,200(PRD)	Residential 7,200 sq. ft.	SFR-Basic
11 108828 RK	R-7,200(PRD)	Residential 7,200 sq. ft.	SFR-Basic
11 108829 RK	R-7,200(PRD)	Residential 7,200 sq. ft.	SFR-Basic
11 108830 RK	R-7,200(PRD)	Residential 7,200 sq. ft.	SFR-Basic
11 108831 RK	R-7,200(PRD)	Residential 7,200 sq. ft.	SFR-Basic
11 108832 RK	R-7,200(PRD)	Residential 7,200 sq. ft.	SFR-Basic
11 108833 RK	R-7,200(PRD)	Residential 7,200 sq. ft.	SFR-Basic
11 108834 RK	R-7,200(PRD)	Residential 7,200 sq. ft.	SFR-Basic
12 101152 RK	R-7,200(PRD)	Residential 7,200 sq. ft.	SFR-Basic
11 108836 RK	R-7,200(PRD)	Residential 7,200 sq. ft.	SFR-Basic
11 108837 RK	R-7,200(PRD)	Residential 7,200 sq. ft.	SFR-Basic
11 108814 RK	R-7,200(PRD)	Residential 7,200 sq. ft.	Single Family Residential
11 108812 RK	R-7,200(PRD)	Residential 7,200 sq. ft.	Single Family Residential
11 108815 RK	R-7,200(PRD)	Residential 7,200 sq. ft.	Single Family Residential
11 108813 RK	R-7,200(PRD)	Residential 7,200 sq. ft.	Single Family Residential
11 107188 RK	R-7,200(PRD)	Residential 7,200 sq. ft.	SFR-Basic
11 107189 RK	R-7,200(PRD)	Residential 7,200 sq. ft.	SFR-Basic
11 107190 RK	R-7,200(PRD)	Residential 7,200 sq. ft.	SFR-Basic
12 101932 RK	R-7,200(PRD)	Residential 7,200 sq. ft.	SFR-Basic
12 101933 RK	R-7,200(PRD)	Residential 7,200 sq. ft.	SFR-Basic
12 101934 RK	R-7,200(PRD)	Residential 7,200 sq. ft.	SFR-Basic
12 106506 RK	R-7,200	Residential 7,200 sq. ft.	SFR-Basic
12 106507 RK	R-7,200	Residential 7,200 sq. ft.	SFR-Basic
12 106095 RK	R-7,200	Residential 7,200 sq. ft.	SFR-Basic
12 107476 RK	R-7,200	Residential 7,200 sq. ft.	SFR-Basic

Accessory Dwelling Units

Index # - File Name: 1.0022 - Single Family Dwellings Data\_Snohomish County.pdf

12 107477 RK	R-7,200	Residential 7,200 sq. ft.	SFR-Basic
12 108456 RK	R-7,200	Residential 7,200 sq. ft.	SFR-Basic
12 109262 RK	R-7,200	Residential 7,200 sq. ft.	SFR-Basic
12 110233 RK	R-7,200	Residential 7,200 sq. ft.	SFR-Basic
12 110234 RK	R-7,200	Residential 7,200 sq. ft.	SFR-Basic
12 107478 RK	R-7,200	Residential 7,200 sq. ft.	SFR-Basic
12 107957 RK	R-7,200	Residential 7,200 sq. ft.	SFR-Basic
12 107958 RK	R-7,200	Residential 7,200 sq. ft.	SFR-Basic
10 109125 RK	R-7,200(PRD)	Residential 7,200 sq. ft.	SFR-Basic
10 109126 RK	R-7,200(PRD)	Residential 7,200 sq. ft.	SFR-Basic
10 109127 RK	R-7,200(PRD)	Residential 7,200 sq. ft.	SFR-Basic
10 109128 RK	R-7,200(PRD)	Residential 7,200 sq. ft.	SFR-Basic
10 109129 RK	R-7,200(PRD)	Residential 7,200 sq. ft.	SFR-Basic
12 100388 RK	R-7,200	Residential 7,200 sq. ft.	SFR-Basic
12 101712 RK	R-7,200	Residential 7,200 sq. ft.	SFR-Basic
12 107278 RK	R-7,200	Residential 7,200 sq. ft.	SFR-Basic
12 100008 RK	R-7,200	Residential 7,200 sq. ft.	SFR-Basic
12 104994 RK	R-7,200	Residential 7,200 sq. ft.	SFR-Basic
12 104995 RK	R-7,200	Residential 7,200 sq. ft.	SFR-Basic
12 104996 RK	R-7,200	Residential 7,200 sq. ft.	SFR-Basic
12 104023 RK	R-7,200	Residential 7,200 sq. ft.	SFR-Basic
12 104997 RK	R-7,200	Residential 7,200 sq. ft.	SFR-Basic
12 104998 RK	R-7,200	Residential 7,200 sq. ft.	SFR-Basic
12 106457 RK	R-7,200	Residential 7,200 sq. ft.	SFR-Basic
12 100743 RK	R-7,200	Residential 7,200 sq. ft.	Single Family Residential
12 100747 RK	R-7,200	Residential 7,200 sq. ft.	Single Family Residential
12 107561 RK	R-7,200	Residential 7,200 sq. ft.	SFR-Basic
12 107562 RK	R-7,200	Residential 7,200 sq. ft.	SFR-Basic
12 107564 RK	R-7,200	Residential 7,200 sq. ft.	SFR-Basic
12 107565 RK	R-7,200	Residential 7,200 sq. ft.	SFR-Basic
12 107566 RK	R-7,200	Residential 7,200 sq. ft.	SFR-Basic
12 107567 RK	R-7,200	Residential 7,200 sq. ft.	SFR-Basic
12 107568 RK	R-7,200	Residential 7,200 sq. ft.	SFR-Basic
12 107569 RK	R-7,200	Residential 7,200 sq. ft.	SFR-Basic
12 107570 RK	R-7,200	Residential 7,200 sq. ft.	SFR-Basic
12 107559 RK	R-7,200	Residential 7,200 sq. ft.	Single Family Residential
12 100389 RK	R-7,200	Residential 7,200 sq. ft.	SFR-Basic
10 105511 RK	R-5	Rural-5 Acre	Single Family Residential
10 109215 RK	LDMR	Low Density Multiple Reside	SFR-Basic
10 109216 RK	LDMR	Low Density Multiple Reside	SFR-Basic
10 109217 RK	LDMR	Low Density Multiple Reside	SFR-Basic
10 109218 RK	LDMR	Low Density Multiple Reside	SFR-Basic
12 107884 RK	LDMR	Low Density Multiple Reside	Single Family Residential
11 108625 RK	R-7,200	Residential 7,200 sq. ft.	Single Family Residential
12 102202 RK	R-9,600	Residential 9,600 sq. ft.	Single Family Residential
12 102206 RK	R-9,600	Residential 9,600 sq. ft.	Single Family Residential
12 102204 RK	R-9,600	Residential 9,600 sq. ft.	Single Family Residential

Accessory Dwelling Units

Index # - File Name: 1.0022 - Single Family Dwellings Data\_Snohomish County.pdf

12 102209 RK	R-9,600	Residential 9,600 sq. ft.	Single Family Residential
12 102208 RK	R-9,600	Residential 9,600 sq. ft.	Single Family Residential
12 104749 RK	R-9,600	Residential 9,600 sq. ft.	Single Family Residential
12 104748 RK	R-9,600	Residential 9,600 sq. ft.	Single Family Residential
12 104750 RK	R-9,600	Residential 9,600 sq. ft.	Single Family Residential
12 102770 RK	R-7,200	Residential 7,200 sq. ft.	SFR-Basic
12 102849 RK	R-7,200	Residential 7,200 sq. ft.	SFR-Basic
12 103696 RK	R-7,200	Residential 7,200 sq. ft.	SFR-Basic
12 100099 RK	R-7,200	Residential 7,200 sq. ft.	SFR-Basic
12 102771 RK	R-7,200	Residential 7,200 sq. ft.	SFR-Basic
12 103697 RK	R-7,200	Residential 7,200 sq. ft.	SFR-Basic
12 102509 RK	R-7,200	Residential 7,200 sq. ft.	SFR-Basic
11 109815 RK	R-7,200	Residential 7,200 sq. ft.	SFR-Basic
11 109816 RK	R-7,200	Residential 7,200 sq. ft.	SFR-Basic
11 109817 RK	R-7,200	Residential 7,200 sq. ft.	SFR-Basic
12 106094 RK	R-7,200	Residential 7,200 sq. ft.	SFR-Basic
12 104795 RK	R-7,200	Residential 7,200 sq. ft.	SFR-Basic
12 104796 RK	R-7,200	Residential 7,200 sq. ft.	SFR-Basic
12 104792 RK	R-7,200	Residential 7,200 sq. ft.	SFR-Basic
12 105574 RK	R-7,200	Residential 7,200 sq. ft.	SFR-Basic
12 106505 RK	R-7,200	Residential 7,200 sq. ft.	SFR-Basic
12 104797 RK	R-7,200	Residential 7,200 sq. ft.	SFR-Basic
12 108454 RK	R-7,200	Residential 7,200 sq. ft.	SFR-Basic
12 108455 RK	R-7,200	Residential 7,200 sq. ft.	SFR-Basic
12 110232 RK	R-7,200	Residential 7,200 sq. ft.	SFR-Basic
12 110774 RK	R-7,200	Residential 7,200 sq. ft.	SFR-Basic
12 110775 RK	R-7,200	Residential 7,200 sq. ft.	SFR-Basic
12 103399 RK	R-7,200	Residential 7,200 sq. ft.	SFR-Basic
12 103400 RK	R-7,200	Residential 7,200 sq. ft.	SFR-Basic
12 103401 RK	R-7,200	Residential 7,200 sq. ft.	SFR-Basic
12 104794 RK	R-7,200	Residential 7,200 sq. ft.	SFR-Basic
12 109260 RK	R-7,200	Residential 7,200 sq. ft.	SFR-Basic
12 109261 RK	R-7,200	Residential 7,200 sq. ft.	SFR-Basic
12 105572 RK	R-7,200	Residential 7,200 sq. ft.	SFR-Basic
12 105573 RK	R-7,200	Residential 7,200 sq. ft.	SFR-Basic
12 103744 RK	R-5	Rural-5 Acre	Single Family Residential
12 104909 RK	R-5	Rural-5 Acre	Single Family Residential
12 102165 RK	R-5	Rural-5 Acre	Single Family Residential
12 100381 RK	R-7,200	Residential 7,200 sq. ft.	SFR-Basic
12 102064 RK	R-7,200	Residential 7,200 sq. ft.	SFR-Basic
12 100380 RK	R-7,200	Residential 7,200 sq. ft.	SFR-Basic
12 103040 RK	R-7,200	Residential 7,200 sq. ft.	SFR-Basic
12 103039 RK	R-7,200	Residential 7,200 sq. ft.	SFR-Basic
12 102434 RK	CITY	City	SFR-Basic
12 101226 RK	R-7,200	Residential 7,200 sq. ft.	SFR-Basic
12 101227 RK	R-7,200	Residential 7,200 sq. ft.	SFR-Basic
12 100756 RK	CITY	City	SFR-Basic

Accessory Dwelling Units

Index # - File Name: 1.0022 - Single Family Dwellings Data\_Snohomish County.pdf

12 100757 RK	CITY	City	SFR-Basic
12 100758 RK	CITY	City	SFR-Basic
12 100759 RK	CITY	City	SFR-Basic
12 100760 RK	CITY	City	SFR-Basic
12 100598 RK	CITY	City	SFR-Basic
12 100599 RK	CITY	City	SFR-Basic
12 100682 RK	CITY	City	SFR-Basic
12 100600 RK	CITY	City	SFR-Basic
12 100601 RK	CITY	City	SFR-Basic
12 100602 RK	CITY	City	SFR-Basic
12 100683 RK	CITY	City	SFR-Basic
12 102435 RK	CITY	City	SFR-Basic
12 102185 RK	R-7,200	Residential 7,200 sq. ft.	SFR-Basic
12 100538 RK	R-5	Rural-5 Acre	Single Family Residential
12 108785 RK	R-5	Rural-5 Acre	Single Family Residential
12 108786 RK	R-5	Rural-5 Acre	Single Family Residential
12 104579 RK	R-5	Rural-5 Acre	Single Family Residential
12 101142 RK	R-5	Rural-5 Acre	Single Family Residential
12 107819 RK	R-5	Rural-5 Acre	Single Family Residential
12 107816 RK	R-5	Rural-5 Acre	Single Family Residential
12 101752 RK	R-9,600	Residential 9,600 sq. ft.	SFR-Basic
12 104540 RK	R-9,600	Residential 9,600 sq. ft.	SFR-Basic
12 103164 RK	R-9,600	Residential 9,600 sq. ft.	SFR-Basic
12 103165 RK	R-9,600	Residential 9,600 sq. ft.	SFR-Basic
12 103166 RK	R-9,600	Residential 9,600 sq. ft.	SFR-Basic
12 103167 RK	R-9,600	Residential 9,600 sq. ft.	SFR-Basic
12 102171 RK	R-9,600	Residential 9,600 sq. ft.	SFR-Basic
12 103168 RK	R-9,600	Residential 9,600 sq. ft.	SFR-Basic
12 102536 RK	R-9,600	Residential 9,600 sq. ft.	SFR-Basic
12 101519 RK	R-9,600	Residential 9,600 sq. ft.	SFR-Basic
12 101753 RK	R-9,600	Residential 9,600 sq. ft.	SFR-Basic
12 102394 RK	R-9,600	Residential 9,600 sq. ft.	SFR-Basic
12 103693 RK	R-5	Rural-5 Acre	Single Family Residential
12 101751 RK	R-9,600	Residential 9,600 sq. ft.	SFR-Basic
12 102170 RK	R-9,600	Residential 9,600 sq. ft.	SFR-Basic
12 102173 RK	R-9,600	Residential 9,600 sq. ft.	Single Family Residential
12 100857 RK	R-7,200	Residential 7,200 sq. ft.	SFR-Basic
12 100858 RK	R-7,200	Residential 7,200 sq. ft.	SFR-Basic
12 107578 RK	R-7,200(PRD)	Residential 7,200 sq. ft.	SFR-Basic
12 107579 RK	R-7,200(PRD)	Residential 7,200 sq. ft.	SFR-Basic
12 104024 RK	R-7,200(PRD)	Residential 7,200 sq. ft.	SFR-Basic
12 100061 RK	R-7,200	Residential 7,200 sq. ft.	SFR-Basic
12 100062 RK	R-7,200	Residential 7,200 sq. ft.	SFR-Basic
11 109893 RK	R-7,200	Residential 7,200 sq. ft.	SFR-Basic
12 101938 RK	R-7,200	Residential 7,200 sq. ft.	SFR-Basic
12 100859 RK	R-7,200	Residential 7,200 sq. ft.	SFR-Basic
12 101230 RK	R-7,200	Residential 7,200 sq. ft.	SFR-Basic



Accessory Dwelling Units

Index # - File Name: 1.0022 - Single Family Dwellings Data\_Snohomish County.pdf

12 100564 RK	R-7,200	Residential 7,200 sq. ft.	SFR-Basic
12 101231 RK	R-7,200	Residential 7,200 sq. ft.	SFR-Basic
12 102183 RK	R-7,200	Residential 7,200 sq. ft.	SFR-Basic
12 102184 RK	R-7,200	Residential 7,200 sq. ft.	SFR-Basic
12 102108 RK	R-7,200	Residential 7,200 sq. ft.	SFR-Basic
12 103176 RK	R-7,200	Residential 7,200 sq. ft.	SFR-Basic
12 103805 RK	R-7,200	Residential 7,200 sq. ft.	SFR-Basic
12 101937 RK	R-7,200	Residential 7,200 sq. ft.	SFR-Basic
12 101639 RK	R-7,200	Residential 7,200 sq. ft.	SFR-Basic
12 103738 RK	R-5	Rural-5 Acre	Single Family Residential
12 103737 RK	R-5	Rural-5 Acre	Single Family Residential
12 106082 RK	F	Forestry	Single Family Residential
12 104446 RK	R-5	Rural-5 Acre	SFR-Basic
12 106033 RK	R-5	Rural-5 Acre	SFR-Basic
12 106866 RK	R-5	Rural-5 Acre	Single Family Residential
12 107039 000 01 RK	R-5 : RC	Rural Conservation : Rural-5	Single Family Residential
12 106467 RK	R-9,600	Residential 9,600 sq. ft.	Single Family Residential
12 106584 RK	R-5	Rural-5 Acre	SFR-Basic
12 107333 RK	R-5	Rural-5 Acre	Single Family Residential
12 107287 RK	R-7,200	Residential 7,200 sq. ft.	SFR-Basic
12 107288 RK	R-7,200	Residential 7,200 sq. ft.	SFR-Basic
12 109290 RK	R-7,200	Residential 7,200 sq. ft.	SFR-Basic
12 109291 RK	R-7,200	Residential 7,200 sq. ft.	SFR-Basic
12 109707 RK	R-7,200	Residential 7,200 sq. ft.	SFR-Basic
12 109292 RK	R-7,200	Residential 7,200 sq. ft.	SFR-Basic
12 109293 RK	R-7,200	Residential 7,200 sq. ft.	SFR-Basic
12 109294 RK	R-7,200	Residential 7,200 sq. ft.	SFR-Basic
12 109295 RK	R-7,200	Residential 7,200 sq. ft.	SFR-Basic
12 107286 RK	R-7,200	Residential 7,200 sq. ft.	SFR-Basic
12 109296 RK	R-7,200	Residential 7,200 sq. ft.	SFR-Basic
12 107953 RK	R-5	Rural-5 Acre	SFR-Basic
12 108188 RK	R-9,600	Residential 9,600 sq. ft.	Single Family Residential
12 110564 RK	R-5	Rural-5 Acre	SFR-Basic
12 110562 RK	R-5	Rural-5 Acre	SFR-Basic
12 110310 RK	R-7,200	Residential 7,200 sq. ft.	SFR-Basic
12 108614 RK	R-9,600	Residential 9,600 sq. ft.	Single Family Residential
12 101367 RK	R-9,600	Residential 9,600 sq. ft.	Single Family Residential
12 103621 RK	R-9,600	Residential 9,600 sq. ft.	SFR-Basic
12 101365 RK	R-9,600	Residential 9,600 sq. ft.	Single Family Residential
12 101638 RK	R-9,600	Residential 9,600 sq. ft.	SFR-Basic
12 101363 RK	R-9,600	Residential 9,600 sq. ft.	SFR-Basic
12 101364 RK	R-9,600	Residential 9,600 sq. ft.	SFR-Basic
12 106364 RK	R-5	Rural-5 Acre	SFR-Basic
12 106369 RK	R-5	Rural-5 Acre	SFR-Basic
12 101366 RK	R-9,600	Residential 9,600 sq. ft.	Single Family Residential
11 100058 RK	R-7,200	Residential 7,200 sq. ft.	SFR-Basic
11 100059 RK	R-7,200	Residential 7,200 sq. ft.	SFR-Basic

Accessory Dwelling Units

Index # - File Name: 1.0022 - Single Family Dwellings Data\_Snohomish County.pdf

12 106362 RK	R-5	Rural-5 Acre	SFR-Basic
12 106368 RK	R-5	Rural-5 Acre	SFR-Basic
12 106247 RK	R-5	Rural-5 Acre	Single Family Residential
12 106244 RK	R-5	Rural-5 Acre	Single Family Residential
12 107290 RK	R-5	Rural-5 Acre	Single Family Residential
12 109346 RK	R-5	Rural-5 Acre	Single Family Residential
10 108824 RK	R-5	Rural-5 Acre	SFR-Basic
12 103046 RK	R-5	Rural-5 Acre	SFR-Basic
12 107911 RK	R-5	Rural-5 Acre	Single Family Residential
12 107291 RK	R-5	Rural-5 Acre	Single Family Residential
12 107292 RK	R-5	Rural-5 Acre	Single Family Residential
11 109986 RK	R-5	Rural-5 Acre	Single Family Residential
11 109613 RK	R-5	Rural-5 Acre	Single Family Residential
12 106365 RK	R-5	Rural-5 Acre	SFR-Basic
12 106481 RK	R-5	Rural-5 Acre	SFR-Basic
12 103424 RK	R-5	Rural-5 Acre	SFR-Basic
12 103428 RK	R-5	Rural-5 Acre	SFR-Basic
12 103426 RK	R-5	Rural-5 Acre	SFR-Basic
12 103431 RK	R-5	Rural-5 Acre	SFR-Basic
12 110235 RK	PRD-9,600	Residential 9,600 sq. ft.	SFR-Basic
12 110236 RK	PRD-9,600	Residential 9,600 sq. ft.	SFR-Basic
12 109276 RK	PRD-9,600	Residential 9,600 sq. ft.	SFR-Basic
12 109277 RK	PRD-9,600	Residential 9,600 sq. ft.	SFR-Basic
12 110237 RK	PRD-9,600	Residential 9,600 sq. ft.	SFR-Basic
12 105791 RK	PRD-9,600	Residential 9,600 sq. ft.	SFR-Basic
12 105790 RK	PRD-9,600	Residential 9,600 sq. ft.	SFR-Basic
12 108448 RK	PRD-9,600	Residential 9,600 sq. ft.	SFR-Basic
12 108449 RK	PRD-9,600	Residential 9,600 sq. ft.	SFR-Basic
12 108450 RK	PRD-9,600	Residential 9,600 sq. ft.	SFR-Basic
12 108451 RK	PRD-9,600	Residential 9,600 sq. ft.	SFR-Basic
11 100062 RK	R-7,200	Residential 7,200 sq. ft.	SFR-Basic
10 104854 RK	MR	Multiple Residential	Single Family Residential
10 104789 RK	MR	Multiple Residential	Single Family Residential
10 104793 RK	MR	Multiple Residential	Single Family Residential
10 104822 RK	MR	Multiple Residential	Single Family Residential
10 104850 RK	MR	Multiple Residential	Single Family Residential
10 104827 RK	MR	Multiple Residential	Single Family Residential
10 104823 RK	MR	Multiple Residential	Single Family Residential
10 104825 RK	MR	Multiple Residential	Single Family Residential
10 104826 RK	MR	Multiple Residential	Single Family Residential
10 104828 RK	MR	Multiple Residential	Single Family Residential
10 104830 RK	MR	Multiple Residential	Single Family Residential
10 104832 RK	MR	Multiple Residential	Single Family Residential
10 104851 RK	MR	Multiple Residential	Single Family Residential
10 104852 RK	MR	Multiple Residential	Single Family Residential
10 104853 RK	MR	Multiple Residential	Single Family Residential
10 104855 RK	MR	Multiple Residential	Single Family Residential

Accessory Dwelling Units

Index # - File Name: 1.0022 - Single Family Dwellings Data\_Snohomish County.pdf

10 104856 RK	MR	Multiple Residential	Single Family Residential
10 104857 RK	MR	Multiple Residential	Single Family Residential
10 104790 RK	MR	Multiple Residential	Single Family Residential
10 104791 RK	MR	Multiple Residential	Single Family Residential
10 104792 RK	MR	Multiple Residential	Single Family Residential
10 104794 RK	MR	Multiple Residential	Single Family Residential
10 104795 RK	MR	Multiple Residential	Single Family Residential
10 104796 RK	MR	Multiple Residential	Single Family Residential
12 101305 RK	LDMR	Low Density Multiple Reside	SFR-Basic
12 104025 RK	R-7,200	Residential 7,200 sq. ft.	SFR-Basic
12 105577 RK			SFR-Basic
12 101306 RK	LDMR	Low Density Multiple Reside	SFR-Basic
12 101307 RK	LDMR	Low Density Multiple Reside	SFR-Basic
12 101310 RK	LDMR	Low Density Multiple Reside	SFR-Basic
12 101931 RK	R-7,200(PRD)	Residential 7,200 sq. ft.	SFR-Basic
12 105803 RK	LDMR	Low Density Multiple Reside	Single Family Residential
11 108317 RK	R-7,200	Residential 7,200 sq. ft.	SFR-Basic
12 105072 RK	R-7,200	Residential 7,200 sq. ft.	Single Family Residential
12 108173 RK	R-7,200	Residential 7,200 sq. ft.	SFR-Basic
12 103749 RK	R-7,200	Residential 7,200 sq. ft.	SFR-Basic
12 103747 RK	R-7,200	Residential 7,200 sq. ft.	Single Family Residential
12 103748 RK	R-7,200	Residential 7,200 sq. ft.	Single Family Residential
12 102399 RK	R-7,200	Residential 7,200 sq. ft.	Single Family Residential
12 104430 RK	R-7,200	Residential 7,200 sq. ft.	SFR-Basic
12 103104 RK	R-7,200	Residential 7,200 sq. ft.	Single Family Residential
12 110209 RK	R-7,200	Residential 7,200 sq. ft.	SFR-Basic
12 104431 RK	R-7,200	Residential 7,200 sq. ft.	SFR-Basic
11 109990 RK	R-7,200	Residential 7,200 sq. ft.	Single Family Residential
12 100514 RK	R-7,200	Residential 7,200 sq. ft.	Single Family Residential
12 104113 RK	R-7,200	Residential 7,200 sq. ft.	Single Family Residential
12 100206 RK	R-7,200	Residential 7,200 sq. ft.	Single Family Residential
12 105020 RK	R-7,200	Residential 7,200 sq. ft.	SFR-Basic
12 106019 RK	R-7,200	Residential 7,200 sq. ft.	SFR-Basic
12 103595 RK	R-5	Rural-5 Acre	SFR-Basic
12 109406 RK	R-5	Rural-5 Acre	SFR-Basic
12 108050 RK	R-5	Rural-5 Acre	SFR-Basic
12 107692 RK	R-5	Rural-5 Acre	SFR-Basic
12 107693 RK	R-5	Rural-5 Acre	SFR-Basic
12 107694 RK	R-5	Rural-5 Acre	SFR-Basic
12 103417 RK	R-5	Rural-5 Acre	SFR-Basic
12 102916 RK	R-5	Rural-5 Acre	SFR-Basic
12 103592 RK	R-5	Rural-5 Acre	SFR-Basic
12 108648 RK	R-7,200	Residential 7,200 sq. ft.	SFR-Basic
12 109378 RK	R-7,200	Residential 7,200 sq. ft.	SFR-Basic
12 108649 RK	R-7,200	Residential 7,200 sq. ft.	SFR-Basic
12 108651 RK	R-7,200	Residential 7,200 sq. ft.	SFR-Basic
12 108650 RK	R-7,200	Residential 7,200 sq. ft.	SFR-Basic

Accessory Dwelling Units

Index # - File Name: 1.0022 - Single Family Dwellings Data\_Snohomish County.pdf

12 108647 RK	R-7,200	Residential 7,200 sq. ft.	SFR-Basic
12 109379 RK	R-7,200	Residential 7,200 sq. ft.	SFR-Basic
12 103594 RK	R-5	Rural-5 Acre	SFR-Basic
12 104813 RK	R-7,200	Residential 7,200 sq. ft.	SFR-Basic
12 104810 RK	R-7,200	Residential 7,200 sq. ft.	SFR-Basic
12 104811 RK	R-7,200	Residential 7,200 sq. ft.	SFR-Basic
12 104812 RK	R-7,200	Residential 7,200 sq. ft.	SFR-Basic
12 100400 RK	R-5	Rural-5 Acre	Single Family Residential
12 105422 RK	R-5	Rural-5 Acre	SFR-Basic
12 105424 RK	R-5	Rural-5 Acre	SFR-Basic
12 105401 RK	R-5	Rural-5 Acre	SFR-Basic
12 103302 RK	R-5	Rural-5 Acre	Single Family Residential
12 102117 RK	R-7,200	Residential 7,200 sq. ft.	Single Family Residential
12 110199 RK	R-7,200	Residential 7,200 sq. ft.	Single Family Residential
12 103950 RK	R-7,200	Residential 7,200 sq. ft.	Single Family Residential
12 109479 RK	R-7,200	Residential 7,200 sq. ft.	Single Family Residential
12 107988 RK	R-5	Rural-5 Acre	Single Family Residential
11 109401 RK	R-5	Rural-5 Acre	SFR-Basic
11 109402 RK	R-5	Rural-5 Acre	SFR-Basic
12 106282 RK	R-5	Rural-5 Acre	SFR-Basic
12 106283 RK	R-5	Rural-5 Acre	SFR-Basic
12 103768 RK	R-5	Rural-5 Acre	SFR-Basic
12 108894 RK	R-5	Rural-5 Acre	SFR-Basic
12 103767 RK	R-5	Rural-5 Acre	SFR-Basic
12 100867 RK	LDMR	Low Density Multiple Reside	SFR-Basic
12 100438 RK	LDMR	Low Density Multiple Reside	SFR-Basic
12 102506 RK	LDMR	Low Density Multiple Reside	SFR-Basic
12 100868 RK	LDMR	Low Density Multiple Reside	SFR-Basic
12 102507 RK	LDMR	Low Density Multiple Reside	SFR-Basic
12 106594 RK	R-5	Rural-5 Acre	SFR-Basic
12 106596 RK	R-5	Rural-5 Acre	SFR-Basic
12 106595 RK	R-5	Rural-5 Acre	SFR-Basic
12 101880 RK	R-7,200(PRD)	Residential 7,200 sq. ft.	Single Family Residential
12 104018 RK	R-7,200(PRD)	Residential 7,200 sq. ft.	Single Family Residential
12 100751 RK	R-7,200(PRD)	Residential 7,200 sq. ft.	Single Family Residential
11 109979 RK	R-7,200	Residential 7,200 sq. ft.	Single Family Residential
12 110198 RK	R-7,200	Residential 7,200 sq. ft.	Single Family Residential
12 103949 RK	R-7,200	Residential 7,200 sq. ft.	Single Family Residential
11 109977 RK	R-7,200	Residential 7,200 sq. ft.	Single Family Residential
12 105742 RK	R-7,200	Residential 7,200 sq. ft.	Single Family Residential
12 100469 RK	LDMR	Low Density Multiple Reside	SFR-Basic
12 100437 RK	LDMR	Low Density Multiple Reside	SFR-Basic
12 100097 RK	LDMR	Low Density Multiple Reside	SFR-Basic
12 101571 RK	LDMR	Low Density Multiple Reside	SFR-Basic
11 105352 RK	R-7,200	Residential 7,200 sq. ft.	SFR-Basic
12 105267 RK	R-7,200	Residential 7,200 sq. ft.	SFR-Basic
12 104614 RK	R-7,200	Residential 7,200 sq. ft.	SFR-Basic

Accessory Dwelling Units

Index # - File Name: 1.0022 - Single Family Dwellings Data\_Snohomish County.pdf

12 105269 RK	R-7,200	Residential 7,200 sq. ft.	SFR-Basic
12 102911 RK	R-7,200	Residential 7,200 sq. ft.	SFR-Basic
12 105270 RK	R-7,200	Residential 7,200 sq. ft.	SFR-Basic
12 102062 RK	R-7,200	Residential 7,200 sq. ft.	SFR-Basic
12 104615 RK	R-7,200	Residential 7,200 sq. ft.	SFR-Basic
12 104616 RK	R-7,200	Residential 7,200 sq. ft.	SFR-Basic
12 106723 RK	R-7,200	Residential 7,200 sq. ft.	SFR-Basic
12 104247 RK	R-7,200	Residential 7,200 sq. ft.	SFR-Basic
12 105268 RK	R-7,200	Residential 7,200 sq. ft.	SFR-Basic
12 102838 RK	R-7,200	Residential 7,200 sq. ft.	SFR-Basic
12 105610 RK	R-7,200	Residential 7,200 sq. ft.	Single Family Residential
12 101636 RK	R-7,200	Residential 7,200 sq. ft.	SFR-Basic
12 104856 RK	PRD-7,200	Residential 7,200 sq. ft.	Single Family Residential
12 104469 RK	PRD-7,200	Residential 7,200 sq. ft.	Single Family Residential
12 103870 RK	PRD-7,200	Residential 7,200 sq. ft.	Single Family Residential
12 110253 RK	PRD-7,200	Residential 7,200 sq. ft.	Single Family Residential
12 107572 RK	PRD-7,200	Residential 7,200 sq. ft.	Single Family Residential
12 107243 RK	PRD-7,200	Residential 7,200 sq. ft.	Single Family Residential
12 105100 RK	PRD-7,200	Residential 7,200 sq. ft.	Single Family Residential
12 109363 RK	PRD-7,200	Residential 7,200 sq. ft.	Single Family Residential
12 109365 RK	PRD-7,200	Residential 7,200 sq. ft.	Single Family Residential
12 105101 RK	PRD-7,200	Residential 7,200 sq. ft.	Single Family Residential
12 110254 RK	PRD-7,200	Residential 7,200 sq. ft.	Single Family Residential
12 110252 RK	PRD-7,200	Residential 7,200 sq. ft.	Single Family Residential
12 109361 RK	PRD-7,200	Residential 7,200 sq. ft.	Single Family Residential
12 100444 RK	PRD-7,200	Residential 7,200 sq. ft.	Single Family Residential
12 100707 RK	PRD-7,200	Residential 7,200 sq. ft.	Single Family Residential
12 107571 RK	PRD-7,200	Residential 7,200 sq. ft.	Single Family Residential
12 110249 RK	PRD-7,200	Residential 7,200 sq. ft.	Single Family Residential
12 104466 RK	PRD-7,200	Residential 7,200 sq. ft.	Single Family Residential
12 100944 RK	R-7,200(PRD)	Residential 7,200 sq. ft.	Single Family Residential
12 105202 RK	R-7,200(PRD)	Residential 7,200 sq. ft.	Single Family Residential
12 105018 RK	R-7,200(PRD)	Residential 7,200 sq. ft.	Single Family Residential
12 100445 RK	R-7,200(PRD)	Residential 7,200 sq. ft.	Single Family Residential
12 100266 RK	R-7,200(PRD)	Residential 7,200 sq. ft.	Single Family Residential
12 101419 RK	R-7,200(PRD)	Residential 7,200 sq. ft.	Single Family Residential
12 100943 RK	R-7,200(PRD)	Residential 7,200 sq. ft.	Single Family Residential
12 102112 RK	R-7,200(PRD)	Residential 7,200 sq. ft.	Single Family Residential
12 101233 RK	R-7,200(PRD)	Residential 7,200 sq. ft.	Single Family Residential
12 102923 RK	R-7,200(PRD)	Residential 7,200 sq. ft.	Single Family Residential
12 102324 RK	R-7,200(PRD)	Residential 7,200 sq. ft.	Single Family Residential
12 105017 RK	R-7,200(PRD)	Residential 7,200 sq. ft.	Single Family Residential
12 105203 RK	R-7,200(PRD)	Residential 7,200 sq. ft.	Single Family Residential
12 103602 RK	R-7,200(PRD)	Residential 7,200 sq. ft.	Single Family Residential
12 105510 RK	R-7,200(PRD)	Residential 7,200 sq. ft.	Single Family Residential
12 105507 RK	R-7,200(PRD)	Residential 7,200 sq. ft.	Single Family Residential
12 104800 RK	R-7,200(PRD)	Residential 7,200 sq. ft.	Single Family Residential

Accessory Dwelling Units

Index # - File Name: 1.0022 - Single Family Dwellings Data\_Snohomish County.pdf

12 103183 RK	R-7,200(PRD)	Residential 7,200 sq. ft.	Single Family Residential
12 100752 RK	R-7,200(PRD)	Residential 7,200 sq. ft.	Single Family Residential
12 105019 RK	R-7,200(PRD)	Residential 7,200 sq. ft.	Single Family Residential
12 105509 RK	R-7,200(PRD)	Residential 7,200 sq. ft.	Single Family Residential
12 103408 RK	R-7,200(PRD)	Residential 7,200 sq. ft.	Single Family Residential
11 109826 RK	R-7,200(PRD)	Residential 7,200 sq. ft.	Single Family Residential
12 102706 RK	R-7,200(PRD)	Residential 7,200 sq. ft.	Single Family Residential
12 102924 RK	R-7,200(PRD)	Residential 7,200 sq. ft.	Single Family Residential
12 103410 RK	R-7,200(PRD)	Residential 7,200 sq. ft.	Single Family Residential
12 100541 RK	R-7,200(PRD)	Residential 7,200 sq. ft.	Single Family Residential
12 100540 RK	R-7,200(PRD)	Residential 7,200 sq. ft.	Single Family Residential
12 102503 RK	R-7,200(PRD)	Residential 7,200 sq. ft.	Single Family Residential
12 101420 RK	R-7,200(PRD)	Residential 7,200 sq. ft.	Single Family Residential
12 103601 RK	R-7,200(PRD)	Residential 7,200 sq. ft.	Single Family Residential
12 101881 RK	R-7,200(PRD)	Residential 7,200 sq. ft.	Single Family Residential
12 101199 RK	R-7,200	Residential 7,200 sq. ft.	Single Family Residential
12 100387 RK	R-7,200	Residential 7,200 sq. ft.	SFR-Basic
12 102323 RK	R-7,200(PRD)	Residential 7,200 sq. ft.	Single Family Residential
11 109825 RK	R-7,200(PRD)	Residential 7,200 sq. ft.	Single Family Residential
12 100265 RK	R-7,200(PRD)	Residential 7,200 sq. ft.	Single Family Residential
12 102061 RK	R-7,200	Residential 7,200 sq. ft.	SFR-Basic
11 109316 RK	R-7,200	Residential 7,200 sq. ft.	SFR-Basic
12 104022 RK	R-7,200	Residential 7,200 sq. ft.	SFR-Basic
12 103627 RK	R-7,200	Residential 7,200 sq. ft.	SFR-Basic
12 100384 RK	R-7,200	Residential 7,200 sq. ft.	SFR-Basic
12 100385 RK	R-7,200	Residential 7,200 sq. ft.	SFR-Basic
12 101711 RK	R-7,200	Residential 7,200 sq. ft.	SFR-Basic
12 107276 RK	R-7,200	Residential 7,200 sq. ft.	SFR-Basic
12 107273 RK	R-7,200	Residential 7,200 sq. ft.	SFR-Basic
12 100386 RK	R-7,200	Residential 7,200 sq. ft.	SFR-Basic
12 103616 RK	R-7,200	Residential 7,200 sq. ft.	SFR-Basic
12 108111 RK	R-7,200	Residential 7,200 sq. ft.	SFR-Basic
12 108112 RK	R-7,200	Residential 7,200 sq. ft.	SFR-Basic
12 108113 RK	R-7,200	Residential 7,200 sq. ft.	SFR-Basic
12 106739 RK	R-7,200	Residential 7,200 sq. ft.	SFR-Basic
12 107272 RK	R-7,200	Residential 7,200 sq. ft.	SFR-Basic
12 107277 RK	R-7,200	Residential 7,200 sq. ft.	SFR-Basic
12 108114 RK	R-7,200	Residential 7,200 sq. ft.	SFR-Basic
12 107870 RK	R-7,200	Residential 7,200 sq. ft.	SFR-Basic
12 102320 RK	R-7,200	Residential 7,200 sq. ft.	SFR-Basic
12 101710 RK	R-7,200	Residential 7,200 sq. ft.	SFR-Basic
12 107303 RK	R-7,200	Residential 7,200 sq. ft.	SFR-Basic
12 105697 RK	R-7,200	Residential 7,200 sq. ft.	SFR-Basic
12 107275 RK	R-7,200	Residential 7,200 sq. ft.	SFR-Basic
12 103630 RK	R-7,200	Residential 7,200 sq. ft.	SFR-Basic
12 107274 RK	R-7,200	Residential 7,200 sq. ft.	SFR-Basic
12 101637 RK	R-7,200	Residential 7,200 sq. ft.	SFR-Basic

Accessory Dwelling Units

Index # - File Name: 1.0022 - Single Family Dwellings Data\_Snohomish County.pdf

12 103628 RK	R-7,200	Residential 7,200 sq. ft.	SFR-Basic
12 103629 RK	R-7,200	Residential 7,200 sq. ft.	SFR-Basic
12 102225 RK	R-7,200	Residential 7,200 sq. ft.	Single Family Residential
12 101709 RK	R-7,200	Residential 7,200 sq. ft.	SFR-Basic
12 107015 RK	PRD-7,200	Residential 7,200 sq. ft.	Single Family Residential
12 104701 RK	PRD-7,200	Residential 7,200 sq. ft.	Single Family Residential
12 104702 RK	PRD-7,200	Residential 7,200 sq. ft.	Single Family Residential
12 105958 000 01 RK	PRD-7,200	Residential 7,200 sq. ft.	Single Family Residential
12 105099 RK	PRD-7,200	Residential 7,200 sq. ft.	Single Family Residential
12 107573 RK	PRD-7,200	Residential 7,200 sq. ft.	Single Family Residential
12 103871 RK	PRD-7,200	Residential 7,200 sq. ft.	Single Family Residential
12 101876 RK	PRD-7,200	Residential 7,200 sq. ft.	Single Family Residential
12 102483 RK	PRD-7,200	Residential 7,200 sq. ft.	Single Family Residential
12 101747 RK	PRD-7,200	Residential 7,200 sq. ft.	Single Family Residential
12 102084 RK	PRD-7,200	Residential 7,200 sq. ft.	Single Family Residential
12 102271 RK	PRD-7,200	Residential 7,200 sq. ft.	Single Family Residential
12 102086 RK	PRD-7,200	Residential 7,200 sq. ft.	Single Family Residential
12 108420 RK	PRD-7,200	Residential 7,200 sq. ft.	Single Family Residential
12 104703 RK	PRD-7,200	Residential 7,200 sq. ft.	Single Family Residential
12 100709 RK	PRD-7,200	Residential 7,200 sq. ft.	Single Family Residential
12 100708 RK	PRD-7,200	Residential 7,200 sq. ft.	Single Family Residential
12 101196 RK	PRD-7,200	Residential 7,200 sq. ft.	Single Family Residential
12 110250 RK	PRD-7,200	Residential 7,200 sq. ft.	Single Family Residential
12 102161 RK	R-5	Rural-5 Acre	Single Family Residential
12 103837 RK	R-5	Rural-5 Acre	Single Family Residential
12 102243 RK	R-5	Rural-5 Acre	SFR-Basic
11 102773 000 01 RK	R-5	Rural-5 Acre	Single Family Res-Combo
12 108661 RK	R-7,200	Residential 7,200 sq. ft.	SFR-Basic
12 110686 RK	R-7,200	Residential 7,200 sq. ft.	SFR-Basic
12 107648 RK	R-7,200	Residential 7,200 sq. ft.	SFR-Basic
12 105004 RK	R-7,200	Residential 7,200 sq. ft.	SFR-Basic
12 110685 RK	R-7,200	Residential 7,200 sq. ft.	SFR-Basic
12 110687 RK	R-7,200	Residential 7,200 sq. ft.	SFR-Basic
12 107647 RK	R-7,200	Residential 7,200 sq. ft.	SFR-Basic
12 107646 RK	R-7,200	Residential 7,200 sq. ft.	SFR-Basic
12 105005 RK	R-7,200	Residential 7,200 sq. ft.	SFR-Basic
12 105000 RK	R-7,200	Residential 7,200 sq. ft.	SFR-Basic
12 105001 RK	R-7,200	Residential 7,200 sq. ft.	SFR-Basic
12 105002 RK	R-7,200	Residential 7,200 sq. ft.	SFR-Basic
12 105003 RK	R-7,200	Residential 7,200 sq. ft.	SFR-Basic
12 100890 RK	R-7,200(PRD)	Residential 7,200 sq. ft.	SFR-Basic
12 100671 RK	R-7,200(PRD)	Residential 7,200 sq. ft.	SFR-Basic
12 100670 RK	R-7,200(PRD)	Residential 7,200 sq. ft.	SFR-Basic
12 104999 RK	R-7,200	Residential 7,200 sq. ft.	SFR-Basic
11 109792 RK	R-7,200	Residential 7,200 sq. ft.	Single Family Residential
11 109370 RK	R-7,200(PRD)	Residential 7,200 sq. ft.	SFR-Basic
12 109689 RK	R-7,200	Residential 7,200 sq. ft.	Single Family Residential

Accessory Dwelling Units

Index # - File Name: 1.0022 - Single Family Dwellings Data\_Snohomish County.pdf

12 106750 RK	R-7,200	Residential 7,200 sq. ft.	Single Family Residential
12 102587 RK	R-7,200	Residential 7,200 sq. ft.	Single Family Residential
12 102115 RK	R-7,200	Residential 7,200 sq. ft.	Single Family Residential
12 104444 RK	R-5	Rural-5 Acre	SFR-Basic
12 105911 RK	R-5	Rural-5 Acre	SFR-Basic
12 102893 RK	R-7,200(PRD)	Residential 7,200 sq. ft.	SFR-Basic
12 108353 RK	R-9,600	Residential 9,600 sq. ft.	Single Family Residential
12 103680 RK	R-7,200(PRD)	Residential 7,200 sq. ft.	SFR-Basic
12 102892 RK	R-7,200(PRD)	Residential 7,200 sq. ft.	SFR-Basic
12 101341 RK			SFR-Basic
12 100623 RK			SFR-Basic
12 100624 RK			SFR-Basic
12 103865 RK			SFR-Basic
12 103866 RK			SFR-Basic
12 102510 RK			SFR-Basic
12 102511 RK			SFR-Basic
12 102195 RK	R-7,200	Residential 7,200 sq. ft.	Single Family Residential
12 105303 RK	R-7,200	Residential 7,200 sq. ft.	Single Family Residential
12 103947 RK	R-7,200	Residential 7,200 sq. ft.	Single Family Residential
12 103047 RK	R-5	Rural-5 Acre	SFR-Basic
12 110195 RK	R-7,200	Residential 7,200 sq. ft.	Single Family Residential
12 106493 RK	R-7,200	Residential 7,200 sq. ft.	Single Family Residential
12 107227 RK	R-7,200	Residential 7,200 sq. ft.	Single Family Residential
12 106490 RK	R-7,200	Residential 7,200 sq. ft.	Single Family Residential
12 108417 RK	R-7,200	Residential 7,200 sq. ft.	Single Family Residential
12 108663 RK	R-7,200	Residential 7,200 sq. ft.	Single Family Residential
12 107162 RK	R-7,200	Residential 7,200 sq. ft.	Single Family Residential
12 107237 RK	R-7,200	Residential 7,200 sq. ft.	Single Family Residential
12 106310 RK	R-7,200	Residential 7,200 sq. ft.	Single Family Residential
12 102488 RK	R-7,200	Residential 7,200 sq. ft.	Single Family Residential
12 102877 RK	R-7,200	Residential 7,200 sq. ft.	Single Family Residential
12 102485 RK	R-7,200	Residential 7,200 sq. ft.	Single Family Residential
12 102487 RK	R-7,200	Residential 7,200 sq. ft.	Single Family Residential
12 102878 RK	R-7,200	Residential 7,200 sq. ft.	Single Family Residential
12 102486 RK	R-7,200	Residential 7,200 sq. ft.	Single Family Residential
12 102592 RK	R-7,200	Residential 7,200 sq. ft.	Single Family Residential
12 102591 RK	R-7,200	Residential 7,200 sq. ft.	Single Family Residential
12 102593 RK	R-7,200	Residential 7,200 sq. ft.	Single Family Residential
12 102590 RK	R-7,200	Residential 7,200 sq. ft.	Single Family Residential
12 107161 RK	R-7,200	Residential 7,200 sq. ft.	Single Family Residential
12 109359 RK	R-7,200	Residential 7,200 sq. ft.	Single Family Residential
12 105102 RK	R-7,200	Residential 7,200 sq. ft.	Single Family Residential
12 106311 RK	R-7,200	Residential 7,200 sq. ft.	Single Family Residential
12 107231 RK	R-7,200	Residential 7,200 sq. ft.	Single Family Residential
12 107234 RK	R-7,200	Residential 7,200 sq. ft.	Single Family Residential
12 107828 RK	R-7,200	Residential 7,200 sq. ft.	Single Family Residential
12 108416 RK	R-7,200	Residential 7,200 sq. ft.	Single Family Residential



Accessory Dwelling Units

Index # - File Name: 1.0022 - Single Family Dwellings Data\_Snohomish County.pdf

12 106492 RK	R-7,200	Residential 7,200 sq. ft.	Single Family Residential
12 100706 RK	R-7,200	Residential 7,200 sq. ft.	Single Family Residential
12 107826 RK	R-7,200	Residential 7,200 sq. ft.	Single Family Residential
12 109362 RK	R-7,200	Residential 7,200 sq. ft.	Single Family Residential
12 107240 RK	R-7,200	Residential 7,200 sq. ft.	Single Family Residential
12 108662 RK	R-7,200	Residential 7,200 sq. ft.	Single Family Residential
12 109421 RK	R-5	Rural-5 Acre	SFR-Basic
12 104445 RK	R-5	Rural-5 Acre	SFR-Basic
12 101173 RK	R-5	Rural-5 Acre	Single Family Residential
12 109469 RK	R-5	Rural-5 Acre	SFR-Basic
12 109470 RK	R-5	Rural-5 Acre	SFR-Basic
12 109472 RK	R-5	Rural-5 Acre	SFR-Basic
12 107768 RK	R-5	Rural-5 Acre	Single Family Residential
12 103045 RK	R-7,200	Residential 7,200 sq. ft.	SFR-Basic
12 103620 RK	R-7,200	Residential 7,200 sq. ft.	SFR-Basic
12 103042 RK	R-7,200	Residential 7,200 sq. ft.	SFR-Basic
12 103617 RK	R-7,200	Residential 7,200 sq. ft.	SFR-Basic
11 109367 RK	R-7,200	Residential 7,200 sq. ft.	SFR-Basic
12 103618 RK	R-7,200	Residential 7,200 sq. ft.	SFR-Basic
12 103043 RK	R-7,200	Residential 7,200 sq. ft.	SFR-Basic
12 105264 RK	R-7,200	Residential 7,200 sq. ft.	SFR-Basic
12 103619 RK	R-7,200	Residential 7,200 sq. ft.	SFR-Basic
12 103044 RK	R-7,200	Residential 7,200 sq. ft.	SFR-Basic
12 105265 RK	R-7,200	Residential 7,200 sq. ft.	SFR-Basic
12 104461 RK	R-7,200	Residential 7,200 sq. ft.	SFR-Basic
12 105266 RK	R-7,200	Residential 7,200 sq. ft.	SFR-Basic
12 107638 RK	R-5	Rural-5 Acre	SFR-Basic
12 107639 RK	R-5	Rural-5 Acre	SFR-Basic
12 107640 RK	R-5	Rural-5 Acre	SFR-Basic
12 107641 RK	R-5	Rural-5 Acre	SFR-Basic
11 108192 RK	R-5	Rural-5 Acre	Single Family Residential
12 103491 RK	R-5	Rural-5 Acre	Single Family Residential
12 105913 RK	R-5	Rural-5 Acre	SFR-Basic
09 105925 RK	F	Forestry	Single Family Residential
09 105550 RK	F	Forestry	Single Family Residential
12 101812 RK	RB	Rural Business	Single Family Residential
12 100391 RK	PRD-9,600	Residential 9,600 sq. ft.	SFR-Basic
12 100512 RK	PRD-9,600	Residential 9,600 sq. ft.	SFR-Basic
12 107298 RK	PRD-9,600	Residential 9,600 sq. ft.	Single Family Residential
12 106714 RK	PRD-9,600	Residential 9,600 sq. ft.	SFR-Basic
12 106715 RK	PRD-9,600	Residential 9,600 sq. ft.	SFR-Basic
12 107300 RK	PRD-9,600	Residential 9,600 sq. ft.	Single Family Residential
12 107301 RK	PRD-9,600	Residential 9,600 sq. ft.	Single Family Residential
12 106716 RK	PRD-9,600	Residential 9,600 sq. ft.	SFR-Basic
12 106717 RK	PRD-9,600	Residential 9,600 sq. ft.	SFR-Basic
12 105131 RK	LDMR	Low Density Multiple Reside	Single Family Residential
12 105120 RK	R-5	Rural-5 Acre	Single Family Residential

Accessory Dwelling Units

Index # - File Name: 1.0022 - Single Family Dwellings Data\_Snohomish County.pdf

12 102565 RK	R-7,200	Residential 7,200 sq. ft.	SFR-Basic
12 102567 RK	R-7,200	Residential 7,200 sq. ft.	SFR-Basic
12 102566 RK	R-7,200	Residential 7,200 sq. ft.	SFR-Basic
12 104734 RK	R-7,200(PRD)	Residential 7,200 sq. ft.	SFR-Basic
12 104735 RK	R-7,200(PRD)	Residential 7,200 sq. ft.	SFR-Basic
12 104736 RK	R-7,200(PRD)	Residential 7,200 sq. ft.	SFR-Basic
12 104737 RK	R-7,200(PRD)	Residential 7,200 sq. ft.	SFR-Basic
12 104738 RK	R-7,200(PRD)	Residential 7,200 sq. ft.	SFR-Basic
12 105095 RK	R-5	Rural-5 Acre	Single Family Residential
11 107469 RK	R-5	Rural-5 Acre	Single Family Residential
12 109144 RK	R-5	Rural-5 Acre	Single Family Residential
10 106917 000 01 RK	R-5	Rural-5 Acre	Single Family Residential
12 109388 RK	LDMR	Low Density Multiple Reside	SFR-Basic
12 109389 RK	LDMR	Low Density Multiple Reside	SFR-Basic
12 109390 RK	LDMR	Low Density Multiple Reside	SFR-Basic
12 109391 RK	LDMR	Low Density Multiple Reside	SFR-Basic
12 109392 RK	LDMR	Low Density Multiple Reside	SFR-Basic
12 109393 RK	LDMR	Low Density Multiple Reside	SFR-Basic
12 100529 RK	R-7,200	Residential 7,200 sq. ft.	Single Family Residential
12 106604 RK	R-5	Rural-5 Acre	SFR-Basic
12 104443 RK	R-5	Rural-5 Acre	SFR-Basic
12 103932 RK	MR	Multiple Residential	SFR-Basic
12 103933 RK	MR	Multiple Residential	SFR-Basic
12 103317 RK	MR	Multiple Residential	SFR-Basic
12 103318 RK	MR	Multiple Residential	SFR-Basic
12 103319 RK	MR	Multiple Residential	SFR-Basic
12 103321 RK	MR	Multiple Residential	SFR-Basic
12 103322 RK	MR	Multiple Residential	SFR-Basic
12 103323 RK	MR	Multiple Residential	SFR-Basic
12 103324 RK	MR	Multiple Residential	SFR-Basic
12 104442 RK	R-5	Rural-5 Acre	SFR-Basic
12 101865 RK	R-5	Rural-5 Acre	Single Family Residential
12 100359 RK	R-7,200	Residential 7,200 sq. ft.	SFR-Basic
12 100358 RK	R-7,200	Residential 7,200 sq. ft.	SFR-Basic
12 100360 RK	R-7,200	Residential 7,200 sq. ft.	SFR-Basic
12 102568 RK	R-7,200	Residential 7,200 sq. ft.	SFR-Basic
12 102569 RK	R-7,200	Residential 7,200 sq. ft.	SFR-Basic
12 101774 RK	R-5	Rural-5 Acre	Single Family Residential
12 101773 RK	R-5	Rural-5 Acre	SFR-Basic
12 103920 RK	R-5	Rural-5 Acre	SFR-Basic
12 103918 RK	R-5	Rural-5 Acre	SFR-Basic
12 103919 RK	R-5	Rural-5 Acre	SFR-Basic
12 104139 RK	R-5	Rural-5 Acre	SFR-Basic
12 110021 RK	R-5	Rural-5 Acre	Single Family Residential
12 106576 RK	R-5	Rural-5 Acre	Single Family Residential
12 106577 RK	R-5	Rural-5 Acre	Single Family Residential
12 108181 RK	R-5	Rural-5 Acre	Single Family Residential

Accessory Dwelling Units

Index # - File Name: 1.0022 - Single Family Dwellings Data\_Snohomish County.pdf

12 104148 RK	R-5	Rural-5 Acre	SFR-Basic
11 105043 RK	F	Forestry	Single Family Residential
11 109989 RK	R-5	Rural-5 Acre	SFR-Basic
12 107643 RK	R-5	Rural-5 Acre	Single Family Residential
12 103561 RK	R-5	Rural-5 Acre	Single Family Residential
12 101855 RK	RD	Rural Diversification	Single Family Residential
11 107289 RK	R-5	Rural-5 Acre	Single Family Residential
12 102857 RK	R-5	Rural-5 Acre	Single Family Residential
10 104271 RK	WFB	Waterfront Beach	Single Family Residential
10 103355 000 01 RK	RC	Rural Conservation	Single Family Residential
12 104011 RK	R-7,200	Residential 7,200 sq. ft.	Single Family Residential
11 105088 000 01 RK	R-5	Rural-5 Acre	Single Family Residential
12 108724 RK	R-8,400	Residential 8,400 sq. ft.	Single Family Residential
12 107716 RK	R-8,400	Residential 8,400 sq. ft.	Single Family Residential
12 104865 RK	R-8,400	Residential 8,400 sq. ft.	Single Family Residential
12 106349 RK	R-8,400	Residential 8,400 sq. ft.	Single Family Residential
12 105569 RK	R-8,400	Residential 8,400 sq. ft.	Single Family Residential
12 102249 RK	R-5	Rural-5 Acre	Single Family Residential
11 109187 RK	R-5	Rural-5 Acre	Single Family Residential
11 104360 RK	A-10	Agriculture-10 Acre	Single Family Residential
11 108497 RK	R-9,600	Residential 9,600 sq. ft.	Single Family Residential
12 108356 MH	MHP	Mobile Home Park	MH Park-Double Wide
12 110051 MH	MHP	Mobile Home Park	MH Park-Double Wide
12 108278 MH	MHP	Mobile Home Park	MH Park-Double Wide
12 101386 RK	R-5	Rural-5 Acre	Single Family Residential
12 106934 RK	R-5	Rural-5 Acre	Single Family Residential
12 100710 RK	R-5	Rural-5 Acre	Single Family Residential
12 106677 MH	F	Forestry	Double Wide
12 102611 RK	R-5	Rural-5 Acre	Single Family Residential
12 104153 RK	R-5	Rural-5 Acre	Single Family Residential
12 102525 RK	R-5	Rural-5 Acre	Accessory Apt Detached
12 109461 RK	R-5	Rural-5 Acre	Single Family Residential
12 104661 RK	R-5	Rural-5 Acre	Duplex
12 104806 RK	R-5	Rural-5 Acre	Single Family Residential
11 108217 MH	R-5	Rural-5 Acre	Single Wide
11 107437 RK	F	Forestry	Accessory Apt Detached
12 105459 RK	F	Forestry	Single Family Residential
11 109586 RK	R-5	Rural-5 Acre	Single Family Residential
12 105738 RK	F	Forestry	Single Family Residential
12 104224 MH	A-10	Agriculture-10 Acre	Single Wide
12 108713 RK	R-5	Rural-5 Acre	Accessory Apt Detached
12 105009 000 01 RK	MR	Multiple Residential	Single Family Residential
12 104784 RK	R-5	Rural-5 Acre	SFR-Basic
12 103201 RK	R-5	Rural-5 Acre	Single Family Residential
12 104141 RK	R-5	Rural-5 Acre	Single Family Residential
12 105189 RK	R-5	Rural-5 Acre	Single Family Residential
12 104697 RK	R-9,600	Residential 9,600 sq. ft.	Duplex-Basic

Accessory Dwelling Units

Index # - File Name: 1.0022 - Single Family Dwellings Data\_Snohomish County.pdf

12 104234 RK	R-5	Rural-5 Acre	Single Family Residential
12 104236 RK	R-5	Rural-5 Acre	Accessory Apt Detached
12 102066 RK	R-5	Rural-5 Acre	Single Family Residential
12 100968 RK	R-5	Rural-5 Acre	Single Family Residential
11 107658 000 01 RK	R-5	Rural-5 Acre	Single Family Residential
12 104786 RK	R-5	Rural-5 Acre	SFR-Basic
12 104979 RK	PRD-20,000(M	Residential 20,000 sq. ft.	Single Family Residential
12 105816 RK	R-5	Rural-5 Acre	Single Family Residential
12 103909 RK	R-5	Rural-5 Acre	Single Family Residential
12 101425 RK	R-5	Rural-5 Acre	Single Family Residential
09 106201 RK	F	Forestry	Single Family Residential
12 104326 RK	R-5	Rural-5 Acre	Single Family Residential
12 104710 RK	WFB	Waterfront Beach	Single Family Residential
12 106315 RK	R-7,200	Residential 7,200 sq. ft.	Single Family Residential
12 106417 RK	A-10	Agriculture-10 Acre	Single Family Residential
12 102264 RK	R-5	Rural-5 Acre	Single Family Residential
12 100277 RK	R-5	Rural-5 Acre	Single Family Residential
12 109475 RK	PRD-20,000(M	Residential 20,000 sq. ft.	Single Family Residential
10 107027 RK	WFB	Waterfront Beach	SFR-Basic
12 105751 MH	R-5	Rural-5 Acre	Triple Wide
12 103257 RK	R-5	Rural-5 Acre	Single Family Residential
11 108063 RK	R-5	Rural-5 Acre	Single Family Residential
12 109300 RK	MR	Multiple Residential	Duplex
12 104122 RK	R-5	Rural-5 Acre	Single Family Residential
12 109627 RK	LDMR	Low Density Multiple Reside	SFR-Basic
12 102314 RK	R-7,200	Residential 7,200 sq. ft.	Single Family Residential
12 101569 MH	R-7,200	Residential 7,200 sq. ft.	Double Wide
12 108638 RK	R-7,200	Residential 7,200 sq. ft.	Single Family Residential
11 104218 MH	R-5	Rural-5 Acre	Double Wide
12 102805 MH	R-5	Rural-5 Acre	Double Wide
12 105153 MH	R-5	Rural-5 Acre	Double Wide
12 108877 RK	R-5	Rural-5 Acre	Single Family Residential
12 103347 RK	R-5	Rural-5 Acre	Single Family Residential
12 105678 RK	R-5	Rural-5 Acre	Single Family Residential
12 101987 RK	R-5	Rural-5 Acre	Single Family Residential
12 104851 RK	R-5	Rural-5 Acre	SFR-Basic
12 105621 MH	R-5	Rural-5 Acre	Single Wide
12 107433 RK	R-5	Rural-5 Acre	Single Family Residential
11 109252 RK	R-5	Rural-5 Acre	Single Family Residential
11 106373 000 01 RK	R-5	Rural-5 Acre	Single Family Residential
11 107103 RK	R-5	Rural-5 Acre	Single Family Residential
10 105575 000 01 RK	R-5	Rural-5 Acre	Single Family Residential
12 108888 RK	R-5	Rural-5 Acre	Single Family Residential
10 103988 000 01 RK	R-5	Rural-5 Acre	Single Family Residential
12 108138 RK	A-10	Agriculture-10 Acre	Single Family Residential
12 104740 RK	R-5	Rural-5 Acre	Single Family Residential
12 102116 RK	RD	Rural Diversification	Single Family Residential

Accessory Dwelling Units

Index # - File Name: 1.0022 - Single Family Dwellings Data\_Snohomish County.pdf

12 107153 RK	R-5	Rural-5 Acre	Single Family Residential
12 107150 RK	R-5	Rural-5 Acre	Single Family Residential
12 102010 RK	R-5	Rural-5 Acre	Single Family Residential
12 101977 RK	R-5	Rural-5 Acre	Single Family Residential
12 103179 RK	R-5	Rural-5 Acre	Single Family Residential
12 104622 RK	R-8,400	Residential 8,400 sq. ft.	SFR-Basic
12 104623 RK	R-8,400	Residential 8,400 sq. ft.	SFR-Basic
12 104624 RK	R-8,400	Residential 8,400 sq. ft.	SFR-Basic
09 108115 MH	RD	Rural Diversification	Double Wide
10 107210 RK	R-5	Rural-5 Acre	SFR-Basic
12 106537 RK	R-5	Rural-5 Acre	Single Family Residential
13 109686 RK	R-5	Rural-5 Acre	SFR-Basic
12 110794 RK	R-5	Rural-5 Acre	Single Family Residential
13 102786 RK	R-5	Rural-5 Acre	Single Family Residential
13 105894 RK	RC	Rural Conservation	Single Family Residential
13 113732 RK	R-5	Rural-5 Acre	Accessory Apt Detached
13 107172 RK	R-5	Rural-5 Acre	SFR-Basic
13 108866 RK	R-5	Rural-5 Acre	Single Family Residential
13 101677 RK	R-5	Rural-5 Acre	Single Family Residential
13 105628 RK	R-5	Rural-5 Acre	Single Family Residential
13 107154 RK	R-5	Rural-5 Acre	Single Family Residential
13 103502 RK	R-5	Rural-5 Acre	Single Family Residential
13 101627 RK	R-5	Rural-5 Acre	Single Family Residential
11 109770 RK	R-5	Rural-5 Acre	Single Family Residential
13 106539 RK	R-5	Rural-5 Acre	Single Family Residential
13 105902 RK	R-5	Rural-5 Acre	Single Family Residential
12 107708 RK	R-5	Rural-5 Acre	Single Family Residential
13 105296 MH	R-5	Rural-5 Acre	Triple Wide
13 103489 RK	R-5	Rural-5 Acre	Single Family Residential
13 110447 000 01 RK	R-5	Rural-5 Acre	Single Family Residential
13 112801 RK	R-5	Rural-5 Acre	Single Family Residential
11 106290 RK	R-5	Rural-5 Acre	Single Family Residential
13 100535 MH	R-5	Rural-5 Acre	Double Wide
13 110309 RK	R-5	Rural-5 Acre	Single Family Residential
13 109683 RK	R-5	Rural-5 Acre	Single Family Residential
13 101332 RK	R-5	Rural-5 Acre	Single Family Residential
13 110111 RK	R-5	Rural-5 Acre	Single Family Residential
13 110785 RK	R-5	Rural-5 Acre	SFR-Basic
13 104276 RK	R-5	Rural-5 Acre	Single Family Residential
13 103904 RK	R-5	Rural-5 Acre	Single Family Residential
13 104404 RK	R-5	Rural-5 Acre	Single Family Residential
12 109010 RK	R-5	Rural-5 Acre	Single Family Residential
13 108013 RK	R-5	Rural-5 Acre	Single Family Residential
12 103695 RK	R-5	Rural-5 Acre	Single Family Residential
13 102541 RK	R-5	Rural-5 Acre	Single Family Residential
13 105747 RK	RRT-10	Rural Resource Transition-10	Single Family Residential
13 108097 RK	R-5	Rural-5 Acre	Single Family Residential

Accessory Dwelling Units

Index # - File Name: 1.0022 - Single Family Dwellings Data\_Snohomish County.pdf

12 111351 RK	SA-1	Suburban Agriculture-1 Acre	Single Family Residential
13 107143 RK	R-5	Rural-5 Acre	Single Family Residential
13 105563 RK	R-5	Rural-5 Acre	Single Family Residential
13 105564 RK	R-5	Rural-5 Acre	Single Family Residential
13 109953 RK	R-5	Rural-5 Acre	Single Family Residential
13 103343 RK	R-5	Rural-5 Acre	Single Family Residential
12 107112 RK	R-5	Rural-5 Acre	Single Family Residential
13 111290 RK	R-5	Rural-5 Acre	Single Family Residential
13 106309 RK	R-5	Rural-5 Acre	Single Family Residential
13 107112 RK	RRT-10	Rural Resource Transition-10	Single Family Residential
13 107241 RK	RRT-10	Rural Resource Transition-10	Single Family Residential
13 109313 RK	R-5	Rural-5 Acre	Single Family Residential
13 102892 RK	R-5	Rural-5 Acre	Single Family Residential
13 100507 RK	R-7,200	Residential 7,200 sq. ft.	Duplex
13 102059 RK	R-7,200	Residential 7,200 sq. ft.	Duplex-Basic
13 111016 RK	R-7,200	Residential 7,200 sq. ft.	Single Family Residential
13 106535 RK	LDMR	Low Density Multiple Residence	Single Family Residential
13 107204 RK	R-8,400	Residential 8,400 sq. ft.	Single Family Residential
13 107678 RK	WFB	Waterfront Beach	Single Family Residential
10 109488 RK	WFB	Waterfront Beach	Single Family Residential
13 111579 RK	R-7,200	Residential 7,200 sq. ft.	Single Family Residential
13 112590 RK	R-8,400	Residential 8,400 sq. ft.	Single Family Residential
13 109306 RK	R-9,600	Residential 9,600 sq. ft.	Single Family Residential
13 103460 MH	R-5	Rural-5 Acre	Double Wide
12 101798 RK	R-5	Rural-5 Acre	Single Family Residential
11 109598 RK	F and R	Forestry and Recreation	Single Family Residential
10 107028 RK	WFB	Waterfront Beach	SFR-Basic
13 102872 RK	R-5	Rural-5 Acre	Single Family Residential
13 111711 RK	R-9,600	Residential 9,600 sq. ft.	Accessory Apt Detached
13 103908 RK	R-8,400	Residential 8,400 sq. ft.	Single Family Residential
13 114069 RK	R-9,600	Residential 9,600 sq. ft.	Single Family Residential
13 109527 RK	PRD SA-1	Suburban Agriculture-1 Acre	Single Family Residential
13 103719 MH	R-9,600	Residential 9,600 sq. ft.	Double Wide
13 114073 RK	R-5	Rural-5 Acre	Single Family Residential
13 107169 RK	R-5	Rural-5 Acre	Single Family Residential
13 105579 RK	R-5	Rural-5 Acre	Single Family Residential
12 107391 MH	A-10	Agriculture-10 Acre	Single Wide
13 104308 RK	R-5	Rural-5 Acre	Single Family Residential
13 111043 RK	R-7,200	Residential 7,200 sq. ft.	Single Family Residential
13 100564 RK	R-5	Rural-5 Acre	Single Family Residential
13 105734 MH	R-5	Rural-5 Acre	Double Wide
13 102463 RK	MR	Multiple Residential	Single Family Residential
12 111119 RK	R-7,200	Residential 7,200 sq. ft.	SFR-Basic
13 107701 RK	R-8,400	Residential 8,400 sq. ft.	Single Family Residential
12 109821 RK	GC	General Commercial	Single Family Residential
13 104595 RK	R-9,600	Residential 9,600 sq. ft.	Duplex
13 104524 RK	R-8,400	Residential 8,400 sq. ft.	Single Family Residential

Accessory Dwelling Units

Index # - File Name: 1.0022 - Single Family Dwellings Data\_Snohomish County.pdf

13 102400 RK	R-8,400	Residential 8,400 sq. ft.	Single Family Residential
12 111011 RK	R-8,400	Residential 8,400 sq. ft.	Single Family Residential
13 111919 RK	R-8,400	Residential 8,400 sq. ft.	Single Family Residential
13 106246 RK	R-5	Rural-5 Acre	Single Family Residential
13 105695 RK	R-5	Rural-5 Acre	Single Family Residential
13 103783 RK	R-5	Rural-5 Acre	Single Family Residential
13 106123 RK	R-5	Rural-5 Acre	Single Family Residential
13 110783 RK	R-9,600	Residential 9,600 sq. ft.	Single Family Residential
13 113130 RK	PRD-20,000(M	Residential 20,000 sq. ft.	Single Family Residential
13 113309 RK	PRD-20,000(M	Residential 20,000 sq. ft.	Single Family Residential
13 103664 RK	R-7,200	Residential 7,200 sq. ft.	Duplex
13 104115 RK	R-5	Rural-5 Acre	Single Family Residential
13 101175 RK	R-9,600	Residential 9,600 sq. ft.	Duplex
13 111366 RK	R-5	Rural-5 Acre	Single Family Residential
13 104305 RK	R-9,600	Residential 9,600 sq. ft.	Single Family Residential
13 102674 RK	R-9,600	Residential 9,600 sq. ft.	Single Family Residential
13 104692 RK	R-9,600	Residential 9,600 sq. ft.	Single Family Residential
12 107935 000 01 RK	R-5	Rural-5 Acre	Single Family Residential
13 100190 RK	R-5	Rural-5 Acre	Single Family Residential
13 102105 000 01 RK	R-5	Rural-5 Acre	Single Family Residential
13 112579 RK	R-8,400	Residential 8,400 sq. ft.	SFR-Basic
12 111149 RK	LDMR	Low Density Multiple Reside	Single Family Residential
12 110600 MH	A-10	Agriculture-10 Acre	Double Wide
13 111655 RK	R-5	Rural-5 Acre	Single Family Residential
13 104494 RK	R-5	Rural-5 Acre	SFR-Basic
13 110487 RK	R-5	Rural-5 Acre	Single Family Residential
13 103565 MH	NB	Neighborhood Business	MH Park-Double Wide
13 109452 RK	R-5	Rural-5 Acre	Single Family Residential
13 104005 RK	R-5	Rural-5 Acre	Single Family Residential
13 113323 RK	R-5	Rural-5 Acre	SFR-Basic
13 105403 RK	R-5	Rural-5 Acre	Single Family Residential
13 107536 RK	R-5	Rural-5 Acre	Single Family Residential
13 103298 MH	MHP	Mobile Home Park	MH Park-Double Wide
12 111306 MH	MHP	Mobile Home Park	MH Park-Double Wide
13 105980 MH	MHP	Mobile Home Park	MH Park-Double Wide
13 103301 MH	MHP	Mobile Home Park	MH Park-Double Wide
13 102089 MH	MHP	Mobile Home Park	MH Park-Double Wide
13 103007 RK	R-5	Rural-5 Acre	Single Family Residential
13 107500 RK	R-5	Rural-5 Acre	Single Family Residential
13 107088 RK	PRD-7,200	Residential 7,200 sq. ft.	Single Family Residential
13 105312 000 01 RK	R-5	Rural-5 Acre	Single Family Residential
13 107174 RK	R-5	Rural-5 Acre	Single Family Residential
13 111721 RK	R-5	Rural-5 Acre	Single Family Residential
13 106035 RK	R-9,600	Residential 9,600 sq. ft.	Single Family Residential
12 110366 000 01 RK	R-5	Rural-5 Acre	Single Family Residential
13 106842 RK	R-5	Rural-5 Acre	Single Family Residential
13 100574 RK	RRT-10	Rural Resource Transition-10	Single Family Residential

Accessory Dwelling Units

Index # - File Name: 1.0022 - Single Family Dwellings Data\_Snohomish County.pdf

13 100085 RK	RRT-10	Rural Resource Transition-10	Single Family Residential
13 106901 RK	R-5	Rural-5 Acre	Single Family Residential
13 106903 RK	R-5	Rural-5 Acre	Single Family Residential
13 107004 RK	RD	Rural Diversification	Single Family Residential
12 110010 RK	RD	Rural Diversification	Single Family Residential
11 106999 000 01 RK	R-5	Rural-5 Acre	Single Family Residential
12 111117 RK	R-7,200	Residential 7,200 sq. ft.	SFR-Basic
13 104223 RK	A-10	Agriculture-10 Acre	Single Family Residential
13 104207 RK	A-10	Agriculture-10 Acre	Single Family Residential
13 106243 RK	R-5	Rural-5 Acre	Single Family Residential
13 108366 MH	R-5	Rural-5 Acre	Double Wide
13 104241 RK	RRT-10	Rural Resource Transition-10	Single Family Residential
13 113299 RK	R-5	Rural-5 Acre	Single Family Residential
13 112599 RK	R-9,600	Residential 9,600 sq. ft.	Single Family Residential
12 107970 MH	R-5	Rural-5 Acre	Double Wide
13 109526 000 01 RK	R-5	Rural-5 Acre	Single Family Residential
13 105835 RK	R-5	Rural-5 Acre	Single Family Residential
13 107133 RK	R-5	Rural-5 Acre	SFR-Basic
13 103630 RK	R-5	Rural-5 Acre	Single Family Residential
13 102670 RK	R-5	Rural-5 Acre	Single Family Residential
13 102671 RK	R-5	Rural-5 Acre	Single Family Residential
13 102669 RK	R-5	Rural-5 Acre	Single Family Residential
13 105262 RK	R-5	Rural-5 Acre	Single Family Residential
13 106258 RK	R-7,200	Residential 7,200 sq. ft.	Single Family Residential
13 103566 RK	R-5	Rural-5 Acre	Single Family Residential
13 114355 RK	R-7,200	Residential 7,200 sq. ft.	SFR-Basic
13 114360 RK	R-7,200	Residential 7,200 sq. ft.	SFR-Basic
13 112616 RK	R-7,200	Residential 7,200 sq. ft.	SFR-Basic
13 107587 RK	R-5	Rural-5 Acre	Single Family Residential
13 105963 RK	R-5	Rural-5 Acre	Single Family Residential
13 109629 RK	R-5	Rural-5 Acre	Single Family Residential
13 107679 RK	R-5	Rural-5 Acre	Single Family Residential
13 106251 RK	R-5	Rural-5 Acre	Single Family Residential
13 105962 RK	R-5	Rural-5 Acre	Single Family Residential
12 101583 RK	R-5	Rural-5 Acre	Single Family Residential
12 109141 RK	R-5	Rural-5 Acre	Single Family Residential
13 103585 RK	R-5	Rural-5 Acre	Single Family Residential
13 105427 MH	R-5	Rural-5 Acre	Double Wide
12 107485 RK	R-5	Rural-5 Acre	Single Family Residential
13 104074 RK	RC	Rural Conservation	Single Family Residential
13 105230 RK	R-5	Rural-5 Acre	Single Family Residential
13 105240 RK	R-5	Rural-5 Acre	Single Family Residential
13 109401 RK	R-5	Rural-5 Acre	Single Family Residential
12 108734 RK	R-5	Rural-5 Acre	SFR-Basic
12 108735 RK	R-5	Rural-5 Acre	SFR-Basic
12 108736 RK	R-5	Rural-5 Acre	SFR-Basic
12 108738 RK	R-5	Rural-5 Acre	SFR-Basic



Accessory Dwelling Units

Index # - File Name: 1.0022 - Single Family Dwellings Data\_Snohomish County.pdf

12 108739 RK	R-5	Rural-5 Acre	SFR-Basic
13 104199 RK	R-5	Rural-5 Acre	Single Family Residential
12 110032 000 01 RK	R-5	Rural-5 Acre	Single Family Residential
13 102953 RK	R-5	Rural-5 Acre	Single Family Residential
12 111151 RK	R-5	Rural-5 Acre	SFR-Basic
13 104409 RK	R-5	Rural-5 Acre	Single Family Residential
13 101738 RK	R-5	Rural-5 Acre	SFR-Basic
13 107400 RK	R-5	Rural-5 Acre	SFR-Basic
13 108135 RK	R-5	Rural-5 Acre	SFR-Basic
13 101896 RK	R-5	Rural-5 Acre	Single Family Residential
13 102936 RK	R-5	Rural-5 Acre	Single Family Residential
13 107619 RK	R-5	Rural-5 Acre	Single Family Residential
13 102939 RK	R-5	Rural-5 Acre	Single Family Residential
12 111015 RK	R-5	Rural-5 Acre	Single Family Residential
13 100390 RK	R-7,200	Residential 7,200 sq. ft.	Single Family Residential
13 104069 RK	R-7,200	Residential 7,200 sq. ft.	Single Family Residential
13 107498 RK	R-7,200	Residential 7,200 sq. ft.	Single Family Residential
13 108775 RK	R-7,200	Residential 7,200 sq. ft.	Single Family Residential
13 106950 RK	LDMR	Low Density Multiple Reside	SFR-Basic
13 106948 RK	LDMR	Low Density Multiple Reside	SFR-Basic
13 106947 RK	LDMR	Low Density Multiple Reside	SFR-Basic
13 106946 RK	LDMR	Low Density Multiple Reside	SFR-Basic
13 106944 RK	LDMR	Low Density Multiple Reside	SFR-Basic
13 106942 RK	LDMR	Low Density Multiple Reside	SFR-Basic
13 106941 RK	LDMR	Low Density Multiple Reside	SFR-Basic
13 106938 RK	LDMR	Low Density Multiple Reside	Single Family Residential
13 104455 RK	R-7,200	Residential 7,200 sq. ft.	SFR-Basic
13 104456 RK	R-7,200	Residential 7,200 sq. ft.	SFR-Basic
13 104457 RK	R-7,200	Residential 7,200 sq. ft.	SFR-Basic
13 103560 RK	R-5	Rural-5 Acre	Single Family Residential
13 104458 RK	R-7,200	Residential 7,200 sq. ft.	SFR-Basic
13 100584 RK	R-7,200	Residential 7,200 sq. ft.	SFR-Basic
13 100585 RK	R-7,200	Residential 7,200 sq. ft.	SFR-Basic
13 101561 RK	R-7,200	Residential 7,200 sq. ft.	SFR-Basic
13 101559 RK	R-7,200	Residential 7,200 sq. ft.	SFR-Basic
13 105870 RK	R-5	Rural-5 Acre	SFR-Basic
13 108311 RK	R-5	Rural-5 Acre	Single Family Residential
13 101560 RK	R-7,200	Residential 7,200 sq. ft.	SFR-Basic
13 103516 RK	LDMR	Low Density Multiple Reside	SFR-Basic
13 103517 RK	LDMR	Low Density Multiple Reside	SFR-Basic
13 103518 RK	LDMR	Low Density Multiple Reside	SFR-Basic
13 103519 RK	LDMR	Low Density Multiple Reside	SFR-Basic
13 103520 RK	LDMR	Low Density Multiple Reside	SFR-Basic
13 107343 RK	LDMR	Low Density Multiple Reside	SFR-Basic
13 107344 RK	LDMR	Low Density Multiple Reside	SFR-Basic
13 107345 RK	LDMR	Low Density Multiple Reside	SFR-Basic
13 107346 RK	LDMR	Low Density Multiple Reside	SFR-Basic

Accessory Dwelling Units

Index # - File Name: 1.0022 - Single Family Dwellings Data\_Snohomish County.pdf

13 107347 RK	LDMR	Low Density Multiple Reside SFR-Basic	
13 107348 RK	LDMR	Low Density Multiple Reside SFR-Basic	
13 107349 RK	LDMR	Low Density Multiple Reside SFR-Basic	
13 107350 RK	LDMR	Low Density Multiple Reside SFR-Basic	
13 107351 RK	LDMR	Low Density Multiple Reside SFR-Basic	
13 107353 RK	LDMR	Low Density Multiple Reside SFR-Basic	
13 107354 RK	LDMR	Low Density Multiple Reside SFR-Basic	
13 107355 RK	LDMR	Low Density Multiple Reside SFR-Basic	
13 107356 RK	LDMR	Low Density Multiple Reside SFR-Basic	
13 107370 RK	LDMR	Low Density Multiple Reside SFR-Basic	
13 107371 RK	LDMR	Low Density Multiple Reside SFR-Basic	
13 107372 RK	LDMR	Low Density Multiple Reside SFR-Basic	
13 107373 RK	LDMR	Low Density Multiple Reside SFR-Basic	
13 107374 RK	LDMR	Low Density Multiple Reside SFR-Basic	
13 107375 RK	LDMR	Low Density Multiple Reside SFR-Basic	
13 107376 RK	LDMR	Low Density Multiple Reside SFR-Basic	
13 107377 RK	LDMR	Low Density Multiple Reside SFR-Basic	
13 105529 RK	PRD-7,200	Residential 7,200 sq. ft.	Single Family Residential
13 103256 RK	PRD-7,200	Residential 7,200 sq. ft.	Single Family Residential
13 105535 RK	PRD-7,200	Residential 7,200 sq. ft.	Single Family Residential
13 105531 RK	PRD-7,200	Residential 7,200 sq. ft.	Single Family Residential
13 105536 RK	PRD-7,200	Residential 7,200 sq. ft.	Single Family Residential
13 105532 RK	PRD-7,200	Residential 7,200 sq. ft.	Single Family Residential
13 105534 RK	PRD-7,200	Residential 7,200 sq. ft.	Single Family Residential
13 105533 RK	PRD-7,200	Residential 7,200 sq. ft.	Single Family Residential
13 105404 RK	PRD-7,200	Residential 7,200 sq. ft.	Single Family Residential
13 102539 RK	PRD-7,200	Residential 7,200 sq. ft.	Single Family Residential
13 103012 RK	PRD-7,200	Residential 7,200 sq. ft.	Single Family Residential
13 104413 RK	PRD-7,200	Residential 7,200 sq. ft.	Single Family Residential
13 104414 RK	PRD-7,200	Residential 7,200 sq. ft.	Single Family Residential
13 102240 RK	PRD-7,200	Residential 7,200 sq. ft.	Single Family Residential
13 102243 RK	PRD-7,200	Residential 7,200 sq. ft.	Single Family Residential
13 104415 RK	PRD-7,200	Residential 7,200 sq. ft.	Single Family Residential
13 102540 RK	PRD-7,200	Residential 7,200 sq. ft.	Single Family Residential
13 103013 RK	PRD-7,200	Residential 7,200 sq. ft.	Single Family Residential
13 103722 RK	PRD-7,200	Residential 7,200 sq. ft.	Single Family Residential
13 105472 RK	PRD-7,200	Residential 7,200 sq. ft.	Single Family Residential
13 105467 RK	PRD-7,200	Residential 7,200 sq. ft.	Single Family Residential
13 105469 RK	PRD-7,200	Residential 7,200 sq. ft.	Single Family Residential
13 104416 RK	PRD-7,200	Residential 7,200 sq. ft.	Single Family Residential
13 102180 RK	PRD-7,200	Residential 7,200 sq. ft.	Single Family Residential
13 105693 RK	PRD-7,200	Residential 7,200 sq. ft.	Single Family Residential
13 105417 RK	PRD-7,200	Residential 7,200 sq. ft.	Single Family Residential
13 105410 RK	PRD-7,200	Residential 7,200 sq. ft.	Single Family Residential
13 104417 RK	PRD-7,200	Residential 7,200 sq. ft.	Single Family Residential
13 105412 RK	PRD-7,200	Residential 7,200 sq. ft.	Single Family Residential
13 104269 RK	RD	Rural Diversification	Single Family Residential

Accessory Dwelling Units

Index # - File Name: 1.0022 - Single Family Dwellings Data\_Snohomish County.pdf

13 107248 RK	R-5	Rural-5 Acre	Single Family Residential
13 100581 RK	PRD-7,200	Residential 7,200 sq. ft.	Single Family Residential
12 110474 RK	PRD-7,200	Residential 7,200 sq. ft.	Single Family Residential
13 104217 RK	PRD-7,200	Residential 7,200 sq. ft.	Single Family Residential
13 102875 RK	PRD-7,200	Residential 7,200 sq. ft.	Single Family Residential
13 102241 RK	PRD-7,200	Residential 7,200 sq. ft.	Single Family Residential
13 102876 RK	PRD-7,200	Residential 7,200 sq. ft.	Single Family Residential
13 101937 RK	PRD-7,200	Residential 7,200 sq. ft.	Single Family Residential
13 103218 RK	R-7,200	Residential 7,200 sq. ft.	Single Family Residential
13 101504 RK	R-5	Rural-5 Acre	SFR-Basic
13 101503 RK	R-5	Rural-5 Acre	SFR-Basic
13 104523 RK	R-7,200	Residential 7,200 sq. ft.	Single Family Residential
12 110647 RK	R-7,200	Residential 7,200 sq. ft.	Single Family Residential
13 102448 RK	R-7,200	Residential 7,200 sq. ft.	Single Family Residential
13 104529 RK	R-7,200	Residential 7,200 sq. ft.	Single Family Residential
13 103220 RK	R-7,200	Residential 7,200 sq. ft.	Single Family Residential
13 102447 RK	R-7,200	Residential 7,200 sq. ft.	Single Family Residential
13 104527 RK	R-7,200	Residential 7,200 sq. ft.	Single Family Residential
13 104564 RK	R-5	Rural-5 Acre	Single Family Residential
13 103122 RK	R-5	Rural-5 Acre	Single Family Residential
13 103125 000 01 RK	R-5	Rural-5 Acre	Single Family Residential
13 106980 RK	R-7,200	Residential 7,200 sq. ft.	SFR-Basic
13 107942 RK	R-7,200	Residential 7,200 sq. ft.	SFR-Basic
13 106978 RK	R-7,200	Residential 7,200 sq. ft.	SFR-Basic
13 106979 RK	R-7,200	Residential 7,200 sq. ft.	SFR-Basic
13 104438 RK	R-7,200	Residential 7,200 sq. ft.	SFR-Basic
13 104439 RK	R-7,200	Residential 7,200 sq. ft.	SFR-Basic
13 104440 RK	R-7,200	Residential 7,200 sq. ft.	SFR-Basic
13 104441 RK	R-7,200	Residential 7,200 sq. ft.	SFR-Basic
13 104442 RK	R-7,200	Residential 7,200 sq. ft.	SFR-Basic
13 104443 RK	R-7,200	Residential 7,200 sq. ft.	SFR-Basic
13 104444 RK	R-7,200	Residential 7,200 sq. ft.	SFR-Basic
13 106346 RK	R-7,200	Residential 7,200 sq. ft.	SFR-Basic
13 106347 RK	R-7,200	Residential 7,200 sq. ft.	SFR-Basic
13 107385 RK	R-7,200	Residential 7,200 sq. ft.	SFR-Basic
13 107386 RK	R-7,200	Residential 7,200 sq. ft.	SFR-Basic
13 107387 RK	R-7,200	Residential 7,200 sq. ft.	SFR-Basic
13 107388 RK	R-7,200	Residential 7,200 sq. ft.	SFR-Basic
13 107421 RK	R-7,200	Residential 7,200 sq. ft.	SFR-Basic
13 103586 RK	R-7,200	Residential 7,200 sq. ft.	SFR-Basic
13 103731 RK	R-7,200	Residential 7,200 sq. ft.	SFR-Basic
13 103309 RK	R-7,200	Residential 7,200 sq. ft.	SFR-Basic
13 104969 RK	R-7,200	Residential 7,200 sq. ft.	SFR-Basic
13 103732 RK	R-7,200	Residential 7,200 sq. ft.	SFR-Basic
13 107378 RK	R-7,200	Residential 7,200 sq. ft.	SFR-Basic
13 111012 RK	R-7,200	Residential 7,200 sq. ft.	Single Family Residential
13 107246 RK	R-7,200	Residential 7,200 sq. ft.	SFR-Basic

Accessory Dwelling Units

Index # - File Name: 1.0022 - Single Family Dwellings Data\_Snohomish County.pdf

13 101670 RK	R-7,200	Residential 7,200 sq. ft.	SFR-Basic
13 101669 RK	R-7,200	Residential 7,200 sq. ft.	SFR-Basic
13 100104 RK	R-7,200	Residential 7,200 sq. ft.	SFR-Basic
13 102256 RK	R-7,200	Residential 7,200 sq. ft.	SFR-Basic
13 108553 000 01 RK	R-5	Rural-5 Acre	Single Family Residential
13 105125 RK	R-5	Rural-5 Acre	SFR-Basic
13 105131 RK	R-5	Rural-5 Acre	SFR-Basic
13 105130 RK	R-5	Rural-5 Acre	SFR-Basic
13 105128 RK	R-5	Rural-5 Acre	SFR-Basic
13 101343 RK	R-7,200	Residential 7,200 sq. ft.	SFR-Basic
13 102630 RK	R-7,200	Residential 7,200 sq. ft.	SFR-Basic
13 103398 RK	R-7,200	Residential 7,200 sq. ft.	Single Family Residential
13 105928 RK	R-5	Rural-5 Acre	Single Family Residential
13 108676 RK	R-7,200	Residential 7,200 sq. ft.	Duplex
13 105889 RK	R-7,200	Residential 7,200 sq. ft.	SFR-Basic
13 100688 RK	R-7,200	Residential 7,200 sq. ft.	SFR-Basic
13 103847 RK	R-7,200	Residential 7,200 sq. ft.	Single Family Residential
13 102631 RK	R-7,200	Residential 7,200 sq. ft.	SFR-Basic
13 102629 RK	R-7,200	Residential 7,200 sq. ft.	Single Family Residential
13 110381 RK	R-7,200(PRD)	Residential 7,200 sq. ft.	SFR-Basic
13 114421 RK	R-7,200(PRD)	Residential 7,200 sq. ft.	SFR-Basic
13 105287 RK	R-7,200(PRD)	Residential 7,200 sq. ft.	Single Family Residential
13 105288 RK	R-7,200(PRD)	Residential 7,200 sq. ft.	Single Family Residential
13 112329 RK	R-7,200(PRD)	Residential 7,200 sq. ft.	SFR-Basic
13 105286 RK	R-7,200(PRD)	Residential 7,200 sq. ft.	Single Family Residential
13 110395 RK	R-7,200(PRD)	Residential 7,200 sq. ft.	SFR-Basic
13 110382 RK	R-7,200(PRD)	Residential 7,200 sq. ft.	SFR-Basic
13 104381 RK	R-7,200(PRD)	Residential 7,200 sq. ft.	SFR-Basic
13 111918 RK	R-7,200(PRD)	Residential 7,200 sq. ft.	SFR-Basic
13 105289 RK	R-7,200(PRD)	Residential 7,200 sq. ft.	Single Family Residential
13 105704 RK	R-7,200(PRD)	Residential 7,200 sq. ft.	Single Family Residential
13 104397 RK	R-7,200(PRD)	Residential 7,200 sq. ft.	Single Family Residential
13 104893 RK	R-7,200(PRD)	Residential 7,200 sq. ft.	SFR-Basic
13 104382 RK	R-7,200(PRD)	Residential 7,200 sq. ft.	SFR-Basic
13 104398 RK	R-7,200(PRD)	Residential 7,200 sq. ft.	Single Family Residential
13 110383 RK	R-7,200(PRD)	Residential 7,200 sq. ft.	SFR-Basic
13 112701 RK	R-7,200(PRD)	Residential 7,200 sq. ft.	SFR-Basic
13 101346 RK	R-7,200	Residential 7,200 sq. ft.	SFR-Basic
13 108691 RK	R-7,200	Residential 7,200 sq. ft.	Single Family Residential
13 101284 RK	MR	Multiple Residential	SFR-Basic
13 103848 RK	R-7,200	Residential 7,200 sq. ft.	Single Family Residential
13 104084 RK	R-7,200(PRD)	Residential 7,200 sq. ft.	SFR-Basic
13 108583 RK	R-7,200(PRD)	Residential 7,200 sq. ft.	SFR-Basic
13 106242 RK	R-7,200(PRD)	Residential 7,200 sq. ft.	Single Family Residential
13 108584 RK	R-7,200(PRD)	Residential 7,200 sq. ft.	SFR-Basic
13 108803 RK	R-7,200(PRD)	Residential 7,200 sq. ft.	SFR-Basic
13 111682 RK	R-7,200(PRD)	Residential 7,200 sq. ft.	SFR-Basic

Accessory Dwelling Units

Index # - File Name: 1.0022 - Single Family Dwellings Data\_Snohomish County.pdf

12 104892 RK	R-5	Rural-5 Acre	Single Family Residential
12 109956 RK	R-5	Rural-5 Acre	Single Family Residential
13 101276 RK	PRD-9,600	Residential 9,600 sq. ft.	SFR-Basic
13 101277 RK	PRD-9,600	Residential 9,600 sq. ft.	SFR-Basic
13 101278 RK	PRD-9,600	Residential 9,600 sq. ft.	SFR-Basic
13 102611 RK	R-5	Rural-5 Acre	SFR-Basic
13 100053 RK	R-5	Rural-5 Acre	SFR-Basic
13 102613 RK	R-5	Rural-5 Acre	SFR-Basic
13 103966 RK	R-5	Rural-5 Acre	Single Family Residential
13 103962 RK	R-5	Rural-5 Acre	SFR-Basic
13 103965 RK	R-5	Rural-5 Acre	SFR-Basic
13 100044 RK	R-5	Rural-5 Acre	SFR-Basic
13 102609 RK	R-5	Rural-5 Acre	SFR-Basic
13 100051 RK	R-5	Rural-5 Acre	SFR-Basic
13 100050 RK	R-5	Rural-5 Acre	SFR-Basic
13 105510 RK	R-5	Rural-5 Acre	Single Family Residential
13 103960 RK	R-5	Rural-5 Acre	SFR-Basic
13 100046 RK	R-5	Rural-5 Acre	SFR-Basic
13 102606 RK	R-5	Rural-5 Acre	SFR-Basic
13 102614 RK	R-5	Rural-5 Acre	SFR-Basic
13 103834 RK	R-5	Rural-5 Acre	SFR-Basic
13 106042 RK	R-5	Rural-5 Acre	SFR-Basic
13 106046 RK	R-5	Rural-5 Acre	SFR-Basic
13 106047 RK	R-5	Rural-5 Acre	SFR-Basic
13 103832 RK	R-5	Rural-5 Acre	SFR-Basic
13 106037 RK	R-5	Rural-5 Acre	SFR-Basic
13 106040 RK	R-5	Rural-5 Acre	SFR-Basic
13 106036 RK	R-5	Rural-5 Acre	SFR-Basic
13 103828 RK	R-5	Rural-5 Acre	SFR-Basic
13 106039 RK	R-5	Rural-5 Acre	SFR-Basic
13 103840 RK	R-5	Rural-5 Acre	SFR-Basic
13 104031 RK	R-5	Rural-5 Acre	Single Family Residential
13 100049 RK	R-5	Rural-5 Acre	SFR-Basic
13 100047 RK	R-5	Rural-5 Acre	SFR-Basic
13 100048 RK	R-5	Rural-5 Acre	SFR-Basic
13 107134 RK	R-5	Rural-5 Acre	Single Family Residential
13 103959 RK	R-5	Rural-5 Acre	SFR-Basic
13 109620 RK	R-5	Rural-5 Acre	Single Family Residential
13 107314 RK	R-5	Rural-5 Acre	Single Family Residential
13 108669 RK	R-9,600	Residential 9,600 sq. ft.	Single Family Residential
13 107764 RK	R-9,600	Residential 9,600 sq. ft.	Single Family Residential
13 100045 RK	R-5	Rural-5 Acre	SFR-Basic
12 109522 RK	R-5	Rural-5 Acre	Single Family Residential
13 113871 RK	R-7,200	Residential 7,200 sq. ft.	SFR-Basic
13 112565 RK	R-7,200	Residential 7,200 sq. ft.	SFR-Basic
13 110832 RK	R-7,200	Residential 7,200 sq. ft.	SFR-Basic
13 106504 RK	R-7,200	Residential 7,200 sq. ft.	SFR-Basic

Accessory Dwelling Units

Index # - File Name: 1.0022 - Single Family Dwellings Data\_Snohomish County.pdf

13 107617 RK	R-7,200	Residential 7,200 sq. ft.	SFR-Basic
13 107129 RK	R-7,200	Residential 7,200 sq. ft.	SFR-Basic
13 107130 RK	R-7,200	Residential 7,200 sq. ft.	SFR-Basic
13 106505 RK	R-7,200	Residential 7,200 sq. ft.	SFR-Basic
13 108191 RK	R-7,200	Residential 7,200 sq. ft.	SFR-Basic
13 108192 RK	R-7,200	Residential 7,200 sq. ft.	SFR-Basic
13 108193 RK	R-7,200	Residential 7,200 sq. ft.	SFR-Basic
13 108586 RK	R-7,200	Residential 7,200 sq. ft.	SFR-Basic
13 108581 RK	R-7,200	Residential 7,200 sq. ft.	SFR-Basic
13 108582 RK	R-7,200	Residential 7,200 sq. ft.	SFR-Basic
13 111361 RK	R-7,200	Residential 7,200 sq. ft.	SFR-Basic
13 108194 RK	R-7,200	Residential 7,200 sq. ft.	SFR-Basic
13 111678 RK	R-7,200	Residential 7,200 sq. ft.	SFR-Basic
13 106495 RK	R-7,200	Residential 7,200 sq. ft.	SFR-Basic
13 106496 RK	R-7,200	Residential 7,200 sq. ft.	SFR-Basic
13 107121 RK	R-7,200	Residential 7,200 sq. ft.	SFR-Basic
13 107342 RK	R-7,200	Residential 7,200 sq. ft.	SFR-Basic
13 106497 RK	R-7,200	Residential 7,200 sq. ft.	SFR-Basic
13 108587 RK	R-7,200	Residential 7,200 sq. ft.	SFR-Basic
13 109345 RK	R-7,200	Residential 7,200 sq. ft.	SFR-Basic
13 109346 RK	R-7,200	Residential 7,200 sq. ft.	SFR-Basic
13 112694 RK	R-7,200	Residential 7,200 sq. ft.	SFR-Basic
13 105759 RK	R-7,200	Residential 7,200 sq. ft.	Single Family Residential
13 102738 RK	R-7,200	Residential 7,200 sq. ft.	SFR-Basic
13 102739 RK	R-7,200	Residential 7,200 sq. ft.	SFR-Basic
13 105365 RK	R-7,200	Residential 7,200 sq. ft.	Single Family Residential
13 105076 RK	R-7,200	Residential 7,200 sq. ft.	SFR-Basic
13 102353 RK	R-7,200	Residential 7,200 sq. ft.	SFR-Basic
13 102363 RK	R-7,200	Residential 7,200 sq. ft.	SFR-Basic
13 102736 RK	R-7,200	Residential 7,200 sq. ft.	SFR-Basic
13 102737 RK	R-7,200	Residential 7,200 sq. ft.	SFR-Basic
13 105762 RK	R-7,200	Residential 7,200 sq. ft.	SFR-Basic
13 105768 RK	R-7,200	Residential 7,200 sq. ft.	SFR-Basic
13 104299 RK	R-7,200	Residential 7,200 sq. ft.	SFR-Basic
13 102365 RK	R-7,200	Residential 7,200 sq. ft.	SFR-Basic
13 102371 RK	R-7,200	Residential 7,200 sq. ft.	Single Family Residential
13 105363 RK	R-7,200	Residential 7,200 sq. ft.	SFR-Basic
13 105078 RK	R-7,200	Residential 7,200 sq. ft.	SFR-Basic
13 105077 RK	R-7,200	Residential 7,200 sq. ft.	SFR-Basic
13 105079 RK	R-7,200	Residential 7,200 sq. ft.	SFR-Basic
13 105364 RK	R-7,200	Residential 7,200 sq. ft.	SFR-Basic
13 105366 RK	R-7,200	Residential 7,200 sq. ft.	Single Family Residential
13 102470 RK	R-7,200	Residential 7,200 sq. ft.	SFR-Basic
13 102474 RK	R-7,200	Residential 7,200 sq. ft.	SFR-Basic
13 102476 RK	R-7,200	Residential 7,200 sq. ft.	SFR-Basic
13 102471 RK	R-7,200	Residential 7,200 sq. ft.	SFR-Basic
13 105647 RK	R-5	Rural-5 Acre	Single Family Residential

Accessory Dwelling Units

Index # - File Name: 1.0022 - Single Family Dwellings Data\_Snohomish County.pdf

13 105721 RK	R-7,200	Residential 7,200 sq. ft.	SFR-Basic
13 105722 RK	R-7,200	Residential 7,200 sq. ft.	SFR-Basic
13 105723 RK	R-7,200	Residential 7,200 sq. ft.	SFR-Basic
13 105724 RK	R-7,200	Residential 7,200 sq. ft.	SFR-Basic
13 105725 RK	R-7,200	Residential 7,200 sq. ft.	SFR-Basic
13 105726 RK	R-7,200	Residential 7,200 sq. ft.	SFR-Basic
13 104163 RK	R-5	Rural-5 Acre	SFR-Basic
13 103970 RK	F	Forestry	SFR-Basic
13 103976 RK	F	Forestry	Single Family Residential
13 103635 RK	R-5	Rural-5 Acre	Single Family Residential
13 104326 RK	R-5	Rural-5 Acre	Single Family Residential
13 104322 RK	R-5	Rural-5 Acre	Single Family Residential
13 104312 RK	R-5	Rural-5 Acre	SFR-Basic
13 104499 RK	R-9,600	Residential 9,600 sq. ft.	Single Family Residential
13 104498 RK	R-5	Rural-5 Acre	Single Family Residential
13 107305 RK	R-7,200	Residential 7,200 sq. ft.	SFR-Basic
13 107306 RK	R-7,200	Residential 7,200 sq. ft.	SFR-Basic
13 107307 RK	R-7,200	Residential 7,200 sq. ft.	SFR-Basic
13 107308 RK	R-7,200	Residential 7,200 sq. ft.	SFR-Basic
13 107309 RK	R-7,200	Residential 7,200 sq. ft.	SFR-Basic
13 107256 RK	R-7,200	Residential 7,200 sq. ft.	SFR-Basic
13 107257 RK	R-7,200	Residential 7,200 sq. ft.	SFR-Basic
13 103883 RK	R-7,200	Residential 7,200 sq. ft.	SFR-Basic
13 103884 RK	R-7,200	Residential 7,200 sq. ft.	SFR-Basic
13 103885 RK	R-7,200	Residential 7,200 sq. ft.	SFR-Basic
13 103886 RK	R-7,200	Residential 7,200 sq. ft.	SFR-Basic
13 103889 RK	R-7,200	Residential 7,200 sq. ft.	SFR-Basic
13 105653 RK	R-7,200	Residential 7,200 sq. ft.	SFR-Basic
13 105654 RK	R-7,200	Residential 7,200 sq. ft.	SFR-Basic
13 105655 RK	R-7,200	Residential 7,200 sq. ft.	SFR-Basic
13 105671 RK	R-7,200	Residential 7,200 sq. ft.	SFR-Basic
13 105656 RK	R-7,200	Residential 7,200 sq. ft.	SFR-Basic
13 105657 RK	R-7,200	Residential 7,200 sq. ft.	SFR-Basic
13 105658 RK	R-7,200	Residential 7,200 sq. ft.	SFR-Basic
13 105659 RK	R-7,200	Residential 7,200 sq. ft.	SFR-Basic
13 105660 RK	R-7,200	Residential 7,200 sq. ft.	SFR-Basic
13 105661 RK	R-7,200	Residential 7,200 sq. ft.	SFR-Basic
13 105662 RK	R-7,200	Residential 7,200 sq. ft.	SFR-Basic
13 105663 RK	R-7,200	Residential 7,200 sq. ft.	SFR-Basic
13 106006 RK	R-7,200	Residential 7,200 sq. ft.	SFR-Basic
13 105664 RK	R-7,200	Residential 7,200 sq. ft.	SFR-Basic
13 105665 RK	R-7,200	Residential 7,200 sq. ft.	SFR-Basic
13 105666 RK	R-7,200	Residential 7,200 sq. ft.	SFR-Basic
13 106008 RK	R-7,200	Residential 7,200 sq. ft.	SFR-Basic
13 106433 RK	R-7,200	Residential 7,200 sq. ft.	SFR-Basic
13 106009 RK	R-7,200	Residential 7,200 sq. ft.	SFR-Basic
13 106434 RK	R-7,200	Residential 7,200 sq. ft.	SFR-Basic

Accessory Dwelling Units

Index # - File Name: 1.0022 - Single Family Dwellings Data\_Snohomish County.pdf

13 105669 RK	R-7,200	Residential 7,200 sq. ft.	SFR-Basic
13 105670 RK	R-7,200	Residential 7,200 sq. ft.	SFR-Basic
13 106498 RK	R-7,200	Residential 7,200 sq. ft.	SFR-Basic
13 107122 RK	R-7,200	Residential 7,200 sq. ft.	SFR-Basic
13 107123 RK	R-7,200	Residential 7,200 sq. ft.	SFR-Basic
13 107124 RK	R-7,200	Residential 7,200 sq. ft.	SFR-Basic
13 107125 RK	R-7,200	Residential 7,200 sq. ft.	SFR-Basic
13 106499 RK	R-7,200	Residential 7,200 sq. ft.	SFR-Basic
13 106500 RK	R-7,200	Residential 7,200 sq. ft.	SFR-Basic
13 107615 RK	R-7,200	Residential 7,200 sq. ft.	SFR-Basic
13 109570 RK	R-7,200	Residential 7,200 sq. ft.	SFR-Basic
13 109571 RK	R-7,200	Residential 7,200 sq. ft.	SFR-Basic
13 107127 RK	R-7,200	Residential 7,200 sq. ft.	SFR-Basic
13 107616 RK	R-7,200	Residential 7,200 sq. ft.	SFR-Basic
13 107128 RK	R-7,200	Residential 7,200 sq. ft.	SFR-Basic
13 107229 RK	R-7,200	Residential 7,200 sq. ft.	SFR-Basic
13 106503 RK	R-7,200	Residential 7,200 sq. ft.	SFR-Basic
13 113546 RK	R-7,200	Residential 7,200 sq. ft.	SFR-Basic
13 101530 RK	R-5	Rural-5 Acre	Single Family Residential
13 105758 RK	R-7,200	Residential 7,200 sq. ft.	SFR-Basic
13 109363 RK	R-5	Rural-5 Acre	Single Family Residential
13 107480 MH	R-5	Rural-5 Acre	Double Wide
13 107664 RK	R-5	Rural-5 Acre	SFR-Basic
13 112924 RK	R-7,200	Residential 7,200 sq. ft.	SFR-Basic
13 114029 RK	R-7,200	Residential 7,200 sq. ft.	SFR-Basic
13 111907 RK	R-7,200	Residential 7,200 sq. ft.	SFR-Basic
13 112568 RK	R-7,200	Residential 7,200 sq. ft.	SFR-Basic
13 112559 RK	R-7,200	Residential 7,200 sq. ft.	SFR-Basic
13 112560 RK	R-7,200	Residential 7,200 sq. ft.	SFR-Basic
13 108140 RK	R-5	Rural-5 Acre	SFR-Basic
13 107548 RK	R-7,200	Residential 7,200 sq. ft.	SFR-Basic
13 107549 RK	R-7,200	Residential 7,200 sq. ft.	SFR-Basic
13 107551 RK	R-7,200	Residential 7,200 sq. ft.	SFR-Basic
13 107550 RK	R-7,200	Residential 7,200 sq. ft.	SFR-Basic
13 111905 RK	R-7,200	Residential 7,200 sq. ft.	SFR-Basic
13 111906 RK	R-7,200	Residential 7,200 sq. ft.	SFR-Basic
13 112923 RK	R-7,200	Residential 7,200 sq. ft.	SFR-Basic
13 113549 RK	R-7,200	Residential 7,200 sq. ft.	SFR-Basic
13 112563 RK	R-7,200	Residential 7,200 sq. ft.	SFR-Basic
13 112564 RK	R-7,200	Residential 7,200 sq. ft.	SFR-Basic
13 112570 RK	R-7,200	Residential 7,200 sq. ft.	SFR-Basic
13 107735 RK	A-10	Agriculture-10 Acre	Single Family Residential
13 109231 RK	R-5	Rural-5 Acre	Single Family Residential
13 112691 RK	R-5	Rural-5 Acre	Single Family Residential
13 110385 RK	R-7,200	Residential 7,200 sq. ft.	SFR-Basic
13 111079 RK	R-7,200	Residential 7,200 sq. ft.	SFR-Basic
13 110386 RK	R-7,200	Residential 7,200 sq. ft.	SFR-Basic



Accessory Dwelling Units

Index # - File Name: 1.0022 - Single Family Dwellings Data\_Snohomish County.pdf

13 112327 RK	R-7,200	Residential 7,200 sq. ft.	SFR-Basic
13 112328 RK	R-7,200	Residential 7,200 sq. ft.	SFR-Basic
13 108696 RK	R-5	Rural-5 Acre	Single Family Residential
13 112695 RK	R-7,200	Residential 7,200 sq. ft.	SFR-Basic
13 110387 RK	R-7,200	Residential 7,200 sq. ft.	SFR-Basic
13 110830 RK	R-7,200	Residential 7,200 sq. ft.	SFR-Basic
13 111362 RK	R-7,200	Residential 7,200 sq. ft.	SFR-Basic
13 113594 RK	R-7,200	Residential 7,200 sq. ft.	SFR-Basic
13 113595 RK	R-7,200	Residential 7,200 sq. ft.	SFR-Basic
13 103096 RK	R-7,200	Residential 7,200 sq. ft.	Single Family Residential
13 102901 RK	R-7,200	Residential 7,200 sq. ft.	SFR-Basic
13 102902 RK	R-7,200	Residential 7,200 sq. ft.	SFR-Basic
13 102903 RK	R-7,200	Residential 7,200 sq. ft.	SFR-Basic
13 102904 RK	R-7,200	Residential 7,200 sq. ft.	SFR-Basic
13 102905 RK	R-7,200	Residential 7,200 sq. ft.	SFR-Basic
13 102906 RK	R-7,200	Residential 7,200 sq. ft.	SFR-Basic
13 102907 RK	R-7,200	Residential 7,200 sq. ft.	SFR-Basic
13 101859 RK	R-5	Rural-5 Acre	SFR-Basic
13 107296 RK	R-7,200	Residential 7,200 sq. ft.	SFR-Basic
13 107297 RK	R-7,200	Residential 7,200 sq. ft.	SFR-Basic
13 113884 RK	LDMR	Low Density Multiple Reside	SFR-Basic
13 113599 RK	LDMR	Low Density Multiple Reside	SFR-Basic
13 106294 RK	LDMR	Low Density Multiple Reside	SFR-Basic
13 106295 RK	LDMR	Low Density Multiple Reside	SFR-Basic
13 112725 RK	LDMR	Low Density Multiple Reside	SFR-Basic
13 112726 RK	LDMR	Low Density Multiple Reside	SFR-Basic
13 112553 RK	LDMR	Low Density Multiple Reside	SFR-Basic
13 112554 RK	LDMR	Low Density Multiple Reside	SFR-Basic
13 112555 RK	LDMR	Low Density Multiple Reside	SFR-Basic
13 112556 RK	LDMR	Low Density Multiple Reside	SFR-Basic
13 112557 RK	LDMR	Low Density Multiple Reside	SFR-Basic
13 106369 RK	LDMR	Low Density Multiple Reside	SFR-Basic
13 106370 RK	LDMR	Low Density Multiple Reside	SFR-Basic
13 106371 RK	LDMR	Low Density Multiple Reside	SFR-Basic
13 112558 RK	LDMR	Low Density Multiple Reside	SFR-Basic
13 105157 RK	LDMR	Low Density Multiple Reside	SFR-Basic
13 105158 RK	LDMR	Low Density Multiple Reside	SFR-Basic
13 105441 RK	LDMR	Low Density Multiple Reside	SFR-Basic
13 105442 RK	LDMR	Low Density Multiple Reside	SFR-Basic
13 105159 RK	LDMR	Low Density Multiple Reside	SFR-Basic
13 105443 RK	LDMR	Low Density Multiple Reside	SFR-Basic
13 105444 RK	LDMR	Low Density Multiple Reside	SFR-Basic
13 105160 RK	LDMR	Low Density Multiple Reside	SFR-Basic
13 105161 RK	LDMR	Low Density Multiple Reside	SFR-Basic
13 105162 RK	LDMR	Low Density Multiple Reside	SFR-Basic
13 105310 RK	LDMR	Low Density Multiple Reside	Single Family Residential
13 105317 RK	LDMR	Low Density Multiple Reside	Single Family Residential

Accessory Dwelling Units

Index # - File Name: 1.0022 - Single Family Dwellings Data\_Snohomish County.pdf

13 105313 RK	LDMR	Low Density Multiple Reside Single Family Residential
13 105309 RK	LDMR	Low Density Multiple Reside Single Family Residential
13 105315 RK	LDMR	Low Density Multiple Reside Single Family Residential
13 113878 RK	LDMR	Low Density Multiple Reside SFR-Basic
13 113879 RK	LDMR	Low Density Multiple Reside SFR-Basic
13 106288 RK	LDMR	Low Density Multiple Reside SFR-Basic
13 106289 RK	LDMR	Low Density Multiple Reside SFR-Basic
13 106290 RK	LDMR	Low Density Multiple Reside SFR-Basic
13 106362 RK	LDMR	Low Density Multiple Reside SFR-Basic
13 106363 RK	LDMR	Low Density Multiple Reside SFR-Basic
13 107079 RK	LDMR	Low Density Multiple Reside SFR-Basic
13 106364 RK	LDMR	Low Density Multiple Reside SFR-Basic
13 106365 RK	LDMR	Low Density Multiple Reside SFR-Basic
13 106291 RK	LDMR	Low Density Multiple Reside SFR-Basic
13 106292 RK	LDMR	Low Density Multiple Reside SFR-Basic
13 106293 RK	LDMR	Low Density Multiple Reside SFR-Basic
13 106366 RK	LDMR	Low Density Multiple Reside SFR-Basic
13 106367 RK	LDMR	Low Density Multiple Reside SFR-Basic
13 106368 RK	LDMR	Low Density Multiple Reside SFR-Basic
13 112552 RK	LDMR	Low Density Multiple Reside SFR-Basic
13 113597 RK	LDMR	Low Density Multiple Reside SFR-Basic
13 113598 RK	LDMR	Low Density Multiple Reside SFR-Basic
13 113882 RK	LDMR	Low Density Multiple Reside SFR-Basic
13 106296 RK	LDMR	Low Density Multiple Reside SFR-Basic
13 106297 RK	LDMR	Low Density Multiple Reside SFR-Basic
13 105314 RK	LDMR	Low Density Multiple Reside Single Family Residential
13 105308 RK	LDMR	Low Density Multiple Reside Single Family Residential
13 105319 RK	LDMR	Low Density Multiple Reside Single Family Residential
13 104831 RK	R-7,200	Residential 7,200 sq. ft. SFR-Basic
13 104832 RK	R-7,200	Residential 7,200 sq. ft. SFR-Basic
13 106004 RK	R-7,200	Residential 7,200 sq. ft. SFR-Basic
13 104833 RK	R-7,200	Residential 7,200 sq. ft. SFR-Basic
13 104834 RK	R-7,200	Residential 7,200 sq. ft. SFR-Basic
13 106005 RK	R-7,200	Residential 7,200 sq. ft. SFR-Basic
13 104835 RK	R-7,200	Residential 7,200 sq. ft. SFR-Basic
13 106007 RK	R-7,200	Residential 7,200 sq. ft. SFR-Basic
13 104836 RK	R-7,200	Residential 7,200 sq. ft. SFR-Basic
13 104837 RK	R-7,200	Residential 7,200 sq. ft. SFR-Basic
13 106010 RK	R-7,200	Residential 7,200 sq. ft. SFR-Basic
13 104838 RK	R-7,200	Residential 7,200 sq. ft. SFR-Basic
13 104839 RK	R-7,200	Residential 7,200 sq. ft. SFR-Basic
13 107258 RK	R-7,200	Residential 7,200 sq. ft. SFR-Basic
13 107259 RK	R-7,200	Residential 7,200 sq. ft. SFR-Basic
13 107260 RK	R-7,200	Residential 7,200 sq. ft. SFR-Basic
13 107261 RK	R-7,200	Residential 7,200 sq. ft. SFR-Basic
13 107262 RK	R-7,200	Residential 7,200 sq. ft. SFR-Basic
13 107263 RK	R-7,200	Residential 7,200 sq. ft. SFR-Basic

Accessory Dwelling Units

Index # - File Name: 1.0022 - Single Family Dwellings Data\_Snohomish County.pdf

13 107264 RK	R-7,200	Residential 7,200 sq. ft.	SFR-Basic
13 107265 RK	R-7,200	Residential 7,200 sq. ft.	SFR-Basic
13 107266 RK	R-7,200	Residential 7,200 sq. ft.	SFR-Basic
13 107267 RK	R-7,200	Residential 7,200 sq. ft.	SFR-Basic
13 107268 RK	R-7,200	Residential 7,200 sq. ft.	SFR-Basic
13 107269 RK	R-7,200	Residential 7,200 sq. ft.	SFR-Basic
13 107270 RK	R-7,200	Residential 7,200 sq. ft.	SFR-Basic
13 107271 RK	R-7,200	Residential 7,200 sq. ft.	SFR-Basic
13 107272 RK	R-7,200	Residential 7,200 sq. ft.	SFR-Basic
13 107273 RK	R-7,200	Residential 7,200 sq. ft.	SFR-Basic
13 107274 RK	R-7,200	Residential 7,200 sq. ft.	SFR-Basic
13 107275 RK	R-7,200	Residential 7,200 sq. ft.	SFR-Basic
13 107276 RK	R-7,200	Residential 7,200 sq. ft.	SFR-Basic
13 107277 RK	R-7,200	Residential 7,200 sq. ft.	SFR-Basic
13 107278 RK	R-7,200	Residential 7,200 sq. ft.	SFR-Basic
13 107279 RK	R-7,200	Residential 7,200 sq. ft.	SFR-Basic
13 107280 RK	R-7,200	Residential 7,200 sq. ft.	SFR-Basic
13 107281 RK	R-7,200	Residential 7,200 sq. ft.	SFR-Basic
13 101861 RK	R-5	Rural-5 Acre	SFR-Basic
13 101194 RK	R-5	Rural-5 Acre	SFR-Basic
13 101196 RK	R-5	Rural-5 Acre	SFR-Basic
13 101199 RK	R-5	Rural-5 Acre	SFR-Basic
13 101200 RK	R-5	Rural-5 Acre	SFR-Basic
13 101862 RK	R-5	Rural-5 Acre	SFR-Basic
13 101202 RK	R-5	Rural-5 Acre	SFR-Basic
13 101204 RK	R-5	Rural-5 Acre	SFR-Basic
13 105171 RK	R-7,200	Residential 7,200 sq. ft.	Single Family Residential
13 105169 RK	R-7,200	Residential 7,200 sq. ft.	Single Family Residential
13 105172 RK	R-7,200	Residential 7,200 sq. ft.	Single Family Residential
13 105170 RK	R-7,200	Residential 7,200 sq. ft.	Single Family Residential
13 105174 RK	R-7,200	Residential 7,200 sq. ft.	Single Family Residential
13 105168 RK	R-7,200	Residential 7,200 sq. ft.	Single Family Residential
13 105175 RK	R-7,200	Residential 7,200 sq. ft.	Single Family Residential
13 105445 RK	R-7,200	Residential 7,200 sq. ft.	SFR-Basic
13 105446 RK	R-7,200	Residential 7,200 sq. ft.	SFR-Basic
13 105447 RK	R-7,200	Residential 7,200 sq. ft.	SFR-Basic
13 105448 RK	R-7,200	Residential 7,200 sq. ft.	SFR-Basic
13 105449 RK	R-7,200	Residential 7,200 sq. ft.	SFR-Basic
13 105251 RK	R-7,200	Residential 7,200 sq. ft.	SFR-Basic
13 105252 RK	R-7,200	Residential 7,200 sq. ft.	SFR-Basic
13 105253 RK	R-7,200	Residential 7,200 sq. ft.	SFR-Basic
13 105254 RK	R-7,200	Residential 7,200 sq. ft.	SFR-Basic
13 105255 RK	R-7,200	Residential 7,200 sq. ft.	SFR-Basic
13 105450 RK	R-7,200	Residential 7,200 sq. ft.	SFR-Basic
13 105451 RK	R-7,200	Residential 7,200 sq. ft.	SFR-Basic
13 105452 RK	R-7,200	Residential 7,200 sq. ft.	SFR-Basic
13 105256 RK	R-7,200	Residential 7,200 sq. ft.	SFR-Basic

Accessory Dwelling Units

Index # - File Name: 1.0022 - Single Family Dwellings Data\_Snohomish County.pdf

13 105152 RK	LDMR	Low Density Multiple Reside	SFR-Basic
13 105153 RK	LDMR	Low Density Multiple Reside	SFR-Basic
13 105434 RK	LDMR	Low Density Multiple Reside	SFR-Basic
13 105435 RK	LDMR	Low Density Multiple Reside	SFR-Basic
13 105154 RK	LDMR	Low Density Multiple Reside	SFR-Basic
13 105436 RK	LDMR	Low Density Multiple Reside	SFR-Basic
13 105437 RK	LDMR	Low Density Multiple Reside	SFR-Basic
13 106287 RK	LDMR	Low Density Multiple Reside	SFR-Basic
13 105618 RK	LDMR	Low Density Multiple Reside	SFR-Basic
13 105619 RK	LDMR	Low Density Multiple Reside	SFR-Basic
13 105438 RK	LDMR	Low Density Multiple Reside	SFR-Basic
13 105620 RK	LDMR	Low Density Multiple Reside	SFR-Basic
13 105621 RK	LDMR	Low Density Multiple Reside	SFR-Basic
13 105155 RK	LDMR	Low Density Multiple Reside	SFR-Basic
13 105439 RK	LDMR	Low Density Multiple Reside	SFR-Basic
13 105440 RK	LDMR	Low Density Multiple Reside	SFR-Basic
13 105156 RK	LDMR	Low Density Multiple Reside	SFR-Basic
13 103061 RK	R-7,200	Residential 7,200 sq. ft.	SFR-Basic
13 103067 RK	R-7,200	Residential 7,200 sq. ft.	SFR-Basic
13 103068 RK	R-7,200	Residential 7,200 sq. ft.	SFR-Basic
13 103621 RK	R-7,200	Residential 7,200 sq. ft.	SFR-Basic
13 104356 RK	R-7,200	Residential 7,200 sq. ft.	SFR-Basic
13 103062 RK	R-7,200	Residential 7,200 sq. ft.	SFR-Basic
13 104357 RK	R-7,200	Residential 7,200 sq. ft.	SFR-Basic
12 109114 RK	R-5	Rural-5 Acre	Single Family Residential
13 105011 MH	R-5	Rural-5 Acre	Double Wide
12 110748 RK	R-5	Rural-5 Acre	Single Family Residential
13 100739 RK	R-7,200	Residential 7,200 sq. ft.	SFR-Basic
13 100745 RK	R-7,200	Residential 7,200 sq. ft.	SFR-Basic
13 100742 RK	R-7,200	Residential 7,200 sq. ft.	SFR-Basic
13 100741 RK	R-7,200	Residential 7,200 sq. ft.	SFR-Basic
13 100740 RK	R-7,200	Residential 7,200 sq. ft.	SFR-Basic
13 102893 RK	R-7,200	Residential 7,200 sq. ft.	SFR-Basic
13 102894 RK	R-7,200	Residential 7,200 sq. ft.	SFR-Basic
13 102895 RK	R-7,200	Residential 7,200 sq. ft.	SFR-Basic
13 102896 RK	R-7,200	Residential 7,200 sq. ft.	SFR-Basic
13 102897 RK	R-7,200	Residential 7,200 sq. ft.	SFR-Basic
13 102898 RK	R-7,200	Residential 7,200 sq. ft.	SFR-Basic
13 102899 RK	R-7,200	Residential 7,200 sq. ft.	SFR-Basic
13 102900 RK	R-7,200	Residential 7,200 sq. ft.	SFR-Basic
12 110667 RK	R-7,200	Residential 7,200 sq. ft.	SFR-Basic
12 110343 RK	R-7,200	Residential 7,200 sq. ft.	SFR-Basic
12 110668 RK	R-7,200	Residential 7,200 sq. ft.	SFR-Basic
13 101350 RK	R-7,200	Residential 7,200 sq. ft.	Single Family Residential
13 101348 RK	R-7,200	Residential 7,200 sq. ft.	Single Family Residential
13 101349 RK	R-7,200	Residential 7,200 sq. ft.	Single Family Residential
12 110344 RK	R-7,200	Residential 7,200 sq. ft.	SFR-Basic

Accessory Dwelling Units

Index # - File Name: 1.0022 - Single Family Dwellings Data\_Snohomish County.pdf

13 105012 RK	R-9,600	Residential 9,600 sq. ft.	Single Family Residential
13 105861 RK	R-5	Rural-5 Acre	Single Family Residential
13 103025 RK	R-9,600	Residential 9,600 sq. ft.	Single Family Residential
13 104744 RK	R-5	Rural-5 Acre	SFR-Basic
13 103939 RK	R-5	Rural-5 Acre	SFR-Basic
13 104745 RK	R-5	Rural-5 Acre	SFR-Basic
13 105903 RK	R-5	Rural-5 Acre	SFR-Basic
13 103940 RK	R-5	Rural-5 Acre	SFR-Basic
13 105431 RK	R-5	Rural-5 Acre	SFR-Basic
12 110913 RK	R-5	Rural-5 Acre	SFR-Basic
13 104694 RK	R-5	Rural-5 Acre	Single Family Residential
13 108776 RK	R-5	Rural-5 Acre	Single Family Residential
13 107680 RK	R-5	Rural-5 Acre	Single Family Residential
13 106816 RK	R-5	Rural-5 Acre	Single Family Residential
13 106522 RK	R-5	Rural-5 Acre	Single Family Residential
13 104230 000 01 RK	RD	Rural Diversification	Single Family Residential
13 112566 RK	R-7,200	Residential 7,200 sq. ft.	SFR-Basic
13 110515 RK	LDMR	Low Density Multiple Reside	Single Family Residential
13 112366 RK	R-7,200	Residential 7,200 sq. ft.	SFR-Basic
13 112367 RK	R-7,200	Residential 7,200 sq. ft.	SFR-Basic
13 112368 RK	R-7,200	Residential 7,200 sq. ft.	SFR-Basic
13 112369 RK	R-7,200	Residential 7,200 sq. ft.	SFR-Basic
13 115271 RK	R-7,200	Residential 7,200 sq. ft.	SFR-Basic
13 115272 RK	R-7,200	Residential 7,200 sq. ft.	SFR-Basic
13 115273 RK	R-7,200	Residential 7,200 sq. ft.	SFR-Basic
13 115274 RK	R-7,200	Residential 7,200 sq. ft.	SFR-Basic
13 115280 RK	R-7,200	Residential 7,200 sq. ft.	SFR-Basic
13 115281 RK	R-7,200	Residential 7,200 sq. ft.	SFR-Basic
13 115072 RK	R-7,200	Residential 7,200 sq. ft.	SFR-Basic
13 115069 RK	R-7,200	Residential 7,200 sq. ft.	SFR-Basic
13 111215 RK	R-9,600	Residential 9,600 sq. ft.	Single Family Residential
13 114732 RK	R-7,200	Residential 7,200 sq. ft.	SFR-Basic
13 114733 RK	R-7,200	Residential 7,200 sq. ft.	SFR-Basic
13 114729 RK	R-7,200	Residential 7,200 sq. ft.	SFR-Basic
13 114727 RK	R-7,200	Residential 7,200 sq. ft.	SFR-Basic
13 105841 RK	R-7,200	Residential 7,200 sq. ft.	SFR-Basic
13 101273 RK	R-7,200	Residential 7,200 sq. ft.	Single Family Residential
10 107029 RK	WFB	Waterfront Beach	SFR-Basic
10 107031 RK	WFB	Waterfront Beach	SFR-Basic
13 103349 RK	R-5	Rural-5 Acre	Single Family Residential
12 109330 RK	R-5	Rural-5 Acre	Single Family Residential
10 107030 RK	WFB	Waterfront Beach	SFR-Basic
10 107032 RK	WFB	Waterfront Beach	SFR-Basic
13 103905 RK	R-5	Rural-5 Acre	Single Family Residential
12 108200 RK	R-5	Rural-5 Acre	SFR-Basic
13 101847 RK	R-5	Rural-5 Acre	Single Family Residential
13 103982 RK	R-5	Rural-5 Acre	Single Family Residential

Accessory Dwelling Units

Index # - File Name: 1.0022 - Single Family Dwellings Data\_Snohomish County.pdf

13 100146 RK	R-7,200	Residential 7,200 sq. ft.	SFR-Basic
12 103402 RK	R-7,200	Residential 7,200 sq. ft.	SFR-Basic
13 101279 RK	R-7,200	Residential 7,200 sq. ft.	SFR-Basic
13 102093 RK	R-7,200	Residential 7,200 sq. ft.	SFR-Basic
13 102094 RK	R-7,200	Residential 7,200 sq. ft.	SFR-Basic
13 102725 RK	R-7,200	Residential 7,200 sq. ft.	SFR-Basic
13 102726 RK	R-7,200	Residential 7,200 sq. ft.	SFR-Basic
13 104656 RK	R-7,200	Residential 7,200 sq. ft.	SFR-Basic
13 104657 RK	R-7,200	Residential 7,200 sq. ft.	SFR-Basic
13 104571 RK	R-5	Rural-5 Acre	Single Family Residential
13 103831 RK	R-7,200	Residential 7,200 sq. ft.	SFR-Basic
13 104079 RK	R-7,200	Residential 7,200 sq. ft.	SFR-Basic
13 104658 RK	R-7,200	Residential 7,200 sq. ft.	SFR-Basic
13 100965 RK	R-7,200	Residential 7,200 sq. ft.	SFR-Basic
13 102517 RK	R-5	Rural-5 Acre	Single Family Residential
13 102727 RK	R-7,200	Residential 7,200 sq. ft.	SFR-Basic
13 103829 RK	R-7,200	Residential 7,200 sq. ft.	SFR-Basic
13 101280 RK	R-7,200	Residential 7,200 sq. ft.	SFR-Basic
13 103462 RK	R-7,200	Residential 7,200 sq. ft.	SFR-Basic
13 103830 RK	R-7,200	Residential 7,200 sq. ft.	SFR-Basic
13 102528 RK	R-5	Rural-5 Acre	Single Family Residential
13 109204 RK	R-5	Rural-5 Acre	Single Family Residential
13 100898 RK	R-8,400	Residential 8,400 sq. ft.	SFR-Basic
13 100899 RK	R-8,400	Residential 8,400 sq. ft.	SFR-Basic
13 102552 RK	R-8,400	Residential 8,400 sq. ft.	SFR-Basic
13 101869 RK	R-8,400	Residential 8,400 sq. ft.	SFR-Basic
13 103590 RK	R-8,400	Residential 8,400 sq. ft.	SFR-Basic
13 104380 RK	R-8,400	Residential 8,400 sq. ft.	SFR-Basic
13 100163 RK	R-8,400	Residential 8,400 sq. ft.	SFR-Basic
13 102261 RK	R-7,200	Residential 7,200 sq. ft.	SFR-Basic
13 106094 RK	R-7,200	Residential 7,200 sq. ft.	SFR-Basic
13 102262 RK	R-7,200	Residential 7,200 sq. ft.	SFR-Basic
13 102227 RK	R-7,200	Residential 7,200 sq. ft.	SFR-Basic
13 107382 RK	R-7,200	Residential 7,200 sq. ft.	SFR-Basic
12 110058 RK	R-7,200	Residential 7,200 sq. ft.	SFR-Basic
13 111853 RK	R-7,200	Residential 7,200 sq. ft.	Single Family Residential
13 111844 RK	R-7,200	Residential 7,200 sq. ft.	SFR-Basic
13 107424 RK	R-7,200	Residential 7,200 sq. ft.	SFR-Basic
13 107425 RK	R-7,200	Residential 7,200 sq. ft.	SFR-Basic
13 107379 RK	R-7,200	Residential 7,200 sq. ft.	SFR-Basic
13 106348 RK	R-7,200	Residential 7,200 sq. ft.	SFR-Basic
13 106349 RK	R-7,200	Residential 7,200 sq. ft.	SFR-Basic
13 106350 RK	R-7,200	Residential 7,200 sq. ft.	SFR-Basic
13 102803 RK	R-7,200	Residential 7,200 sq. ft.	SFR-Basic
13 104451 RK	R-7,200	Residential 7,200 sq. ft.	SFR-Basic
13 102807 RK	R-7,200	Residential 7,200 sq. ft.	SFR-Basic
13 103279 RK	R-7,200	Residential 7,200 sq. ft.	SFR-Basic

Accessory Dwelling Units

Index # - File Name: 1.0022 - Single Family Dwellings Data\_Snohomish County.pdf

13 105651 RK	R-7,200	Residential 7,200 sq. ft.	SFR-Basic
13 102648 RK	R-7,200	Residential 7,200 sq. ft.	SFR-Basic
13 103657 RK	R-7,200	Residential 7,200 sq. ft.	SFR-Basic
13 102583 RK	R-7,200	Residential 7,200 sq. ft.	SFR-Basic
13 101671 RK	R-7,200	Residential 7,200 sq. ft.	SFR-Basic
13 101672 RK	R-7,200	Residential 7,200 sq. ft.	SFR-Basic
13 103791 RK	LDMR	Low Density Multiple Reside	SFR-Basic
13 103792 RK	LDMR	Low Density Multiple Reside	SFR-Basic
13 103793 RK	LDMR	Low Density Multiple Reside	SFR-Basic
13 103654 RK	R-7,200	Residential 7,200 sq. ft.	SFR-Basic
13 106985 RK	R-7,200	Residential 7,200 sq. ft.	SFR-Basic
13 106986 RK	R-7,200	Residential 7,200 sq. ft.	SFR-Basic
13 106987 RK	R-7,200	Residential 7,200 sq. ft.	SFR-Basic
13 107110 RK	R-7,200	Residential 7,200 sq. ft.	Single Family Residential
13 106992 RK	R-7,200	Residential 7,200 sq. ft.	SFR-Basic
13 106089 RK	R-7,200	Residential 7,200 sq. ft.	SFR-Basic
13 106090 RK	R-7,200	Residential 7,200 sq. ft.	SFR-Basic
13 106091 RK	R-7,200	Residential 7,200 sq. ft.	SFR-Basic
13 106092 RK	R-7,200	Residential 7,200 sq. ft.	SFR-Basic
13 106093 RK	R-7,200	Residential 7,200 sq. ft.	SFR-Basic
13 107944 RK	R-7,200	Residential 7,200 sq. ft.	SFR-Basic
13 102258 RK	R-7,200	Residential 7,200 sq. ft.	SFR-Basic
13 102259 RK	R-7,200	Residential 7,200 sq. ft.	SFR-Basic
13 102260 RK	R-7,200	Residential 7,200 sq. ft.	SFR-Basic
13 100105 RK	R-7,200	Residential 7,200 sq. ft.	SFR-Basic
13 100106 RK	R-7,200	Residential 7,200 sq. ft.	SFR-Basic
13 103794 RK	LDMR	Low Density Multiple Reside	SFR-Basic
13 103795 RK	LDMR	Low Density Multiple Reside	SFR-Basic
13 103796 RK	LDMR	Low Density Multiple Reside	SFR-Basic
13 103797 RK	LDMR	Low Density Multiple Reside	SFR-Basic
13 103798 RK	LDMR	Low Density Multiple Reside	SFR-Basic
13 103799 RK	LDMR	Low Density Multiple Reside	SFR-Basic
13 103800 RK	LDMR	Low Density Multiple Reside	SFR-Basic
13 103801 RK	LDMR	Low Density Multiple Reside	SFR-Basic
13 103802 RK	LDMR	Low Density Multiple Reside	SFR-Basic
13 107805 RK	LDMR	Low Density Multiple Reside	SFR-Basic
13 102257 RK	R-7,200	Residential 7,200 sq. ft.	SFR-Basic
13 106982 RK	R-7,200	Residential 7,200 sq. ft.	SFR-Basic
13 107943 RK	R-7,200	Residential 7,200 sq. ft.	SFR-Basic
13 106983 RK	R-7,200	Residential 7,200 sq. ft.	SFR-Basic
13 106984 RK	R-7,200	Residential 7,200 sq. ft.	SFR-Basic
13 106988 RK	R-7,200	Residential 7,200 sq. ft.	SFR-Basic
13 106989 RK	R-7,200	Residential 7,200 sq. ft.	SFR-Basic
13 106990 RK	R-7,200	Residential 7,200 sq. ft.	SFR-Basic
13 106991 RK	R-7,200	Residential 7,200 sq. ft.	SFR-Basic
13 106981 RK	R-7,200	Residential 7,200 sq. ft.	SFR-Basic
12 108698 RK	R-7,200(PRD)	Residential 7,200 sq. ft.	SFR-Basic

Accessory Dwelling Units

Index # - File Name: 1.0022 - Single Family Dwellings Data\_Snohomish County.pdf

12 108699 RK	R-7,200(PRD)	Residential 7,200 sq. ft.	SFR-Basic
12 108700 RK	R-7,200(PRD)	Residential 7,200 sq. ft.	SFR-Basic
12 108701 RK	R-7,200(PRD)	Residential 7,200 sq. ft.	SFR-Basic
12 108702 RK	R-7,200(PRD)	Residential 7,200 sq. ft.	SFR-Basic
12 108703 RK	R-7,200(PRD)	Residential 7,200 sq. ft.	SFR-Basic
12 108704 RK	R-7,200(PRD)	Residential 7,200 sq. ft.	SFR-Basic
12 108705 RK	R-7,200(PRD)	Residential 7,200 sq. ft.	SFR-Basic
12 108706 RK	R-7,200(PRD)	Residential 7,200 sq. ft.	SFR-Basic
12 108707 RK	R-7,200(PRD)	Residential 7,200 sq. ft.	SFR-Basic
13 103763 RK	R-5	Rural-5 Acre	SFR-Basic
13 103761 RK	R-5	Rural-5 Acre	SFR-Basic
13 103762 RK	R-5	Rural-5 Acre	SFR-Basic
13 103769 RK	R-5	Rural-5 Acre	SFR-Basic
13 103764 RK	R-5	Rural-5 Acre	SFR-Basic
13 103771 RK	R-5	Rural-5 Acre	SFR-Basic
13 103760 RK	R-5	Rural-5 Acre	SFR-Basic
13 106534 RK	R-5	Rural-5 Acre	Single Family Residential
13 106475 RK	R-5	Rural-5 Acre	SFR-Basic
13 106477 RK	R-5	Rural-5 Acre	SFR-Basic
13 106476 RK	R-5	Rural-5 Acre	SFR-Basic
13 103063 RK	R-7,200(PRD)	Residential 7,200 sq. ft.	SFR-Basic
13 102067 RK	R-7,200	Residential 7,200 sq. ft.	SFR-Basic
13 101543 RK	R-7,200(PRD)	Residential 7,200 sq. ft.	SFR-Basic
13 101544 RK	R-7,200(PRD)	Residential 7,200 sq. ft.	SFR-Basic
13 101545 RK	R-7,200(PRD)	Residential 7,200 sq. ft.	SFR-Basic
13 101546 RK	R-7,200(PRD)	Residential 7,200 sq. ft.	SFR-Basic
13 101547 RK	R-7,200(PRD)	Residential 7,200 sq. ft.	SFR-Basic
13 101548 RK	R-7,200(PRD)	Residential 7,200 sq. ft.	SFR-Basic
13 101549 RK	R-7,200(PRD)	Residential 7,200 sq. ft.	SFR-Basic
13 101550 RK	R-7,200(PRD)	Residential 7,200 sq. ft.	SFR-Basic
13 101554 RK	R-7,200(PRD)	Residential 7,200 sq. ft.	SFR-Basic
13 101555 RK	R-7,200(PRD)	Residential 7,200 sq. ft.	SFR-Basic
13 104355 RK	R-7,200(PRD)	Residential 7,200 sq. ft.	SFR-Basic
13 106340 RK	R-7,200(PRD)	Residential 7,200 sq. ft.	SFR-Basic
12 107587 RK	R-7,200(PRD)	Residential 7,200 sq. ft.	SFR-Basic
12 107588 RK	R-7,200(PRD)	Residential 7,200 sq. ft.	SFR-Basic
12 107589 RK	R-7,200(PRD)	Residential 7,200 sq. ft.	SFR-Basic
12 107590 RK	R-7,200(PRD)	Residential 7,200 sq. ft.	SFR-Basic
13 106339 RK	R-7,200(PRD)	Residential 7,200 sq. ft.	SFR-Basic
13 103059 RK	R-7,200(PRD)	Residential 7,200 sq. ft.	SFR-Basic
13 102157 RK	R-7,200(PRD)	Residential 7,200 sq. ft.	SFR-Basic
13 103060 RK	R-7,200(PRD)	Residential 7,200 sq. ft.	SFR-Basic
13 103065 RK	R-7,200(PRD)	Residential 7,200 sq. ft.	SFR-Basic
13 100763 RK	R-7,200(PRD)	Residential 7,200 sq. ft.	SFR-Basic
13 102158 RK	R-7,200(PRD)	Residential 7,200 sq. ft.	SFR-Basic
12 107583 RK	R-7,200(PRD)	Residential 7,200 sq. ft.	SFR-Basic
13 109234 RK	R-5	Rural-5 Acre	Single Family Residential



Accessory Dwelling Units

Index # - File Name: 1.0022 - Single Family Dwellings Data\_Snohomish County.pdf

13 108413 RK	R-5	Rural-5 Acre	Single Family Residential
13 102852 RK	R-8,400	Residential 8,400 sq. ft.	Single Family Residential
13 103591 RK	R-8,400	Residential 8,400 sq. ft.	SFR-Basic
13 102854 RK	R-8,400	Residential 8,400 sq. ft.	SFR-Basic
13 101871 RK	R-8,400	Residential 8,400 sq. ft.	SFR-Basic
13 101872 RK	R-8,400	Residential 8,400 sq. ft.	SFR-Basic
13 101873 RK	R-8,400	Residential 8,400 sq. ft.	SFR-Basic
13 101874 RK	R-8,400	Residential 8,400 sq. ft.	SFR-Basic
13 101875 RK	R-8,400	Residential 8,400 sq. ft.	SFR-Basic
13 102553 RK	R-8,400	Residential 8,400 sq. ft.	SFR-Basic
13 101866 RK	R-8,400	Residential 8,400 sq. ft.	SFR-Basic
13 101867 RK	R-8,400	Residential 8,400 sq. ft.	SFR-Basic
13 101876 RK	R-8,400	Residential 8,400 sq. ft.	SFR-Basic
13 102014 RK	R-8,400	Residential 8,400 sq. ft.	SFR-Basic
13 102853 RK	R-8,400	Residential 8,400 sq. ft.	Single Family Residential
13 112774 RK	R-8,400	Residential 8,400 sq. ft.	SFR-Basic
13 113547 RK	R-8,400	Residential 8,400 sq. ft.	SFR-Basic
13 100900 RK	R-8,400	Residential 8,400 sq. ft.	SFR-Basic
13 101870 RK	R-8,400	Residential 8,400 sq. ft.	SFR-Basic
13 112696 RK	R-8,400	Residential 8,400 sq. ft.	SFR-Basic
13 102263 RK	R-7,200	Residential 7,200 sq. ft.	SFR-Basic
13 106088 RK	R-7,200	Residential 7,200 sq. ft.	SFR-Basic
13 104159 RK	R-5	Rural-5 Acre	Single Family Residential
13 101918 RK	R-5	Rural-5 Acre	Single Family Residential
13 100164 RK	R-8,400	Residential 8,400 sq. ft.	SFR-Basic
13 103926 MH	A-10	Agriculture-10 Acre	Double Wide
13 105376 RK	R-7,200	Residential 7,200 sq. ft.	SFR-Basic
13 105375 RK	R-7,200	Residential 7,200 sq. ft.	SFR-Basic
13 102916 RK	R-7,200	Residential 7,200 sq. ft.	SFR-Basic
12 111024 RK	R-7,200	Residential 7,200 sq. ft.	Single Family Residential
13 102070 RK	R-7,200	Residential 7,200 sq. ft.	SFR-Basic
13 102924 RK	R-7,200	Residential 7,200 sq. ft.	SFR-Basic
13 105872 RK	R-7,200	Residential 7,200 sq. ft.	SFR-Basic
13 104206 RK	RRT-10	Rural Resource Transition-10	Duplex
14 106856 RK	R-5	Rural-5 Acre	SFR-Basic
14 102587 RK	R-5	Rural-5 Acre	Single Family Residential
14 100725 RK	R-5	Rural-5 Acre	Single Family Residential
14 100723 RK	R-5	Rural-5 Acre	Single Family Residential
14 105031 RK	R-5	Rural-5 Acre	Single Family Residential
14 104990 RK	R-5	Rural-5 Acre	Single Family Residential
14 108689 RK	R-5	Rural-5 Acre	SFR-Basic
14 106853 RK	R-5	Rural-5 Acre	SFR-Basic
14 106854 RK	R-5	Rural-5 Acre	SFR-Basic
14 110319 RK	R-5	Rural-5 Acre	SFR-Basic
14 103484 RK	R-5	Rural-5 Acre	Single Family Residential
14 101382 RK	R-7,200	Residential 7,200 sq. ft.	SFR-Basic
13 112728 RK	R-7,200	Residential 7,200 sq. ft.	SFR-Basic

Accessory Dwelling Units

Index # - File Name: 1.0022 - Single Family Dwellings Data\_Snohomish County.pdf

13 112729 RK	R-7,200	Residential 7,200 sq. ft.	SFR-Basic
13 112730 RK	R-7,200	Residential 7,200 sq. ft.	SFR-Basic
14 105493 RK	R-7,200	Residential 7,200 sq. ft.	SFR-Basic
14 105494 RK	R-7,200	Residential 7,200 sq. ft.	SFR-Basic
14 110111 RK	R-7,200	Residential 7,200 sq. ft.	SFR-Basic
14 110112 RK	R-7,200	Residential 7,200 sq. ft.	SFR-Basic
14 106451 RK	R-7,200	Residential 7,200 sq. ft.	SFR-Basic
14 107738 RK	R-7,200	Residential 7,200 sq. ft.	SFR-Basic
14 107739 RK	R-7,200	Residential 7,200 sq. ft.	SFR-Basic
14 109262 RK	R-7,200	Residential 7,200 sq. ft.	Single Family Residential
14 107740 RK	R-7,200	Residential 7,200 sq. ft.	SFR-Basic
14 107741 RK	R-7,200	Residential 7,200 sq. ft.	SFR-Basic
14 107742 RK	R-7,200	Residential 7,200 sq. ft.	SFR-Basic
13 107423 RK	R-7,200	Residential 7,200 sq. ft.	SFR-Basic
14 109587 RK	R-5	Rural-5 Acre	Single Family Residential
13 107380 RK	R-7,200	Residential 7,200 sq. ft.	SFR-Basic
13 107381 RK	R-7,200	Residential 7,200 sq. ft.	SFR-Basic
13 107383 RK	R-7,200	Residential 7,200 sq. ft.	SFR-Basic
13 107384 RK	R-7,200	Residential 7,200 sq. ft.	SFR-Basic
14 100913 RK	R-5	Rural-5 Acre	Single Family Residential
14 100910 RK	R-5	Rural-5 Acre	Single Family Residential
14 105948 RK	R-5	Rural-5 Acre	Single Family Residential
14 108221 RK	R-5	Rural-5 Acre	Single Family Residential
14 110125 RK	R-5	Rural-5 Acre	Single Family Residential
14 105397 RK	R-5	Rural-5 Acre	Single Family Residential
14 106656 MH	R-5	Rural-5 Acre	Double Wide
14 106001 RK	A-10 : RRT-10	Agriculture-10 Acre : Rural R	Single Family Residential
13 115530 RK	R-7,200	Residential 7,200 sq. ft.	SFR-Basic
14 103341 RK	R-7,200	Residential 7,200 sq. ft.	SFR-Basic
14 113720 RK	R-7,200(PRD)	Residential 7,200 sq. ft.	SFR-Basic
14 108293 RK	R-9,600	Residential 9,600 sq. ft.	Single Family Residential
14 108242 000 01 RK	R-5	Rural-5 Acre	Single Family Residential
14 109390 000 01 RK	R-5	Rural-5 Acre	Single Family Residential
14 109382 000 01 RK	R-5	Rural-5 Acre	Single Family Residential
13 115333 RK	R-5	Rural-5 Acre	Single Family Residential
14 106591 RK	R-9,600	Residential 9,600 sq. ft.	SFR-Basic
14 106013 RK	R-9,600	Residential 9,600 sq. ft.	SFR-Basic
14 112008 RK	R-9,600	Residential 9,600 sq. ft.	SFR-Basic
14 106014 RK	R-9,600	Residential 9,600 sq. ft.	SFR-Basic
14 112009 RK	R-9,600	Residential 9,600 sq. ft.	SFR-Basic
14 106015 RK	R-9,600	Residential 9,600 sq. ft.	SFR-Basic
14 109256 RK	R-9,600	Residential 9,600 sq. ft.	SFR-Basic
14 101119 RK	R-9,600	Residential 9,600 sq. ft.	SFR-Basic
14 106012 RK	R-9,600	Residential 9,600 sq. ft.	SFR-Basic
14 109506 RK	R-9,600	Residential 9,600 sq. ft.	SFR-Basic
14 110254 RK	R-9,600	Residential 9,600 sq. ft.	SFR-Basic
14 110243 RK	R-9,600	Residential 9,600 sq. ft.	SFR-Basic

Accessory Dwelling Units

Index # - File Name: 1.0022 - Single Family Dwellings Data\_Snohomish County.pdf

14 108823 RK	R-9,600	Residential 9,600 sq. ft.	SFR-Basic
14 116177 RK	R-7,200(PRD)	Residential 7,200 sq. ft.	SFR-Basic
14 116178 RK	R-7,200(PRD)	Residential 7,200 sq. ft.	SFR-Basic
14 115144 RK	R-7,200(PRD)	Residential 7,200 sq. ft.	SFR-Basic
14 115145 RK	R-7,200(PRD)	Residential 7,200 sq. ft.	SFR-Basic
14 113721 RK	R-7,200(PRD)	Residential 7,200 sq. ft.	SFR-Basic
14 113722 RK	R-7,200(PRD)	Residential 7,200 sq. ft.	SFR-Basic
14 110863 RK	R-7,200(PRD)	Residential 7,200 sq. ft.	SFR-Basic
14 107366 RK	R-7,200(PRD)	Residential 7,200 sq. ft.	SFR-Basic
14 107371 RK	R-7,200(PRD)	Residential 7,200 sq. ft.	SFR-Basic
14 108088 RK	R-7,200(PRD)	Residential 7,200 sq. ft.	SFR-Basic
14 107367 RK	R-7,200(PRD)	Residential 7,200 sq. ft.	SFR-Basic
14 107372 RK	R-7,200(PRD)	Residential 7,200 sq. ft.	SFR-Basic
14 107373 RK	R-7,200(PRD)	Residential 7,200 sq. ft.	SFR-Basic
14 107374 RK	R-7,200(PRD)	Residential 7,200 sq. ft.	SFR-Basic
14 107375 RK	R-7,200(PRD)	Residential 7,200 sq. ft.	SFR-Basic
14 107376 RK	R-7,200(PRD)	Residential 7,200 sq. ft.	SFR-Basic
14 108089 RK	R-7,200(PRD)	Residential 7,200 sq. ft.	SFR-Basic
14 108090 RK	R-7,200(PRD)	Residential 7,200 sq. ft.	SFR-Basic
14 108091 RK	R-7,200(PRD)	Residential 7,200 sq. ft.	SFR-Basic
14 109251 RK	R-7,200(PRD)	Residential 7,200 sq. ft.	SFR-Basic
14 109252 RK	R-7,200(PRD)	Residential 7,200 sq. ft.	SFR-Basic
14 109253 RK	R-7,200(PRD)	Residential 7,200 sq. ft.	SFR-Basic
14 109254 RK	R-7,200(PRD)	Residential 7,200 sq. ft.	SFR-Basic
14 109556 RK	R-7,200(PRD)	Residential 7,200 sq. ft.	SFR-Basic
14 109557 RK	R-7,200(PRD)	Residential 7,200 sq. ft.	SFR-Basic
14 109558 RK	R-7,200(PRD)	Residential 7,200 sq. ft.	SFR-Basic
14 109559 RK	R-7,200(PRD)	Residential 7,200 sq. ft.	SFR-Basic
14 113723 RK	R-7,200(PRD)	Residential 7,200 sq. ft.	SFR-Basic
14 113724 RK	R-7,200(PRD)	Residential 7,200 sq. ft.	SFR-Basic
14 115146 RK	R-7,200(PRD)	Residential 7,200 sq. ft.	SFR-Basic
14 115147 RK	R-7,200(PRD)	Residential 7,200 sq. ft.	SFR-Basic
14 110706 RK	R-8,400	Residential 8,400 sq. ft.	SFR-Basic
14 110707 RK	R-8,400	Residential 8,400 sq. ft.	SFR-Basic
14 110708 RK	R-8,400	Residential 8,400 sq. ft.	SFR-Basic
14 110709 RK	R-8,400	Residential 8,400 sq. ft.	SFR-Basic
14 112428 RK	R-8,400	Residential 8,400 sq. ft.	SFR-Basic
14 114513 RK	R-8,400	Residential 8,400 sq. ft.	SFR-Basic
14 111042 RK	R-8,400	Residential 8,400 sq. ft.	SFR-Basic
14 109911 RK	R-8,400	Residential 8,400 sq. ft.	SFR-Basic
14 109912 RK	R-8,400	Residential 8,400 sq. ft.	SFR-Basic
14 114514 RK	R-8,400	Residential 8,400 sq. ft.	SFR-Basic
14 109913 RK	R-8,400	Residential 8,400 sq. ft.	SFR-Basic
14 108619 RK	R-8,400	Residential 8,400 sq. ft.	SFR-Basic
14 108620 RK	R-8,400	Residential 8,400 sq. ft.	SFR-Basic
14 108621 RK	R-8,400	Residential 8,400 sq. ft.	SFR-Basic
14 108622 RK	R-8,400	Residential 8,400 sq. ft.	SFR-Basic

Accessory Dwelling Units

Index # - File Name: 1.0022 - Single Family Dwellings Data\_Snohomish County.pdf

14 109149 RK	R-8,400	Residential 8,400 sq. ft.	SFR-Basic
14 113658 RK	R-7,200	Residential 7,200 sq. ft.	Single Family Residential
14 101787 RK	R-7,200	Residential 7,200 sq. ft.	Single Family Residential
14 108480 RK	R-7,200	Residential 7,200 sq. ft.	SFR-Basic
14 107471 RK	R-7,200	Residential 7,200 sq. ft.	SFR-Basic
14 107474 RK	R-7,200	Residential 7,200 sq. ft.	SFR-Basic
14 113437 RK	R-5	Rural-5 Acre	Single Family Residential
13 115373 RK	R-5	Rural-5 Acre	Single Family Residential
14 107763 RK	R-7,200(PRD)	Residential 7,200 sq. ft.	SFR-Basic
14 107756 RK	R-7,200(PRD)	Residential 7,200 sq. ft.	SFR-Basic
14 107450 RK	R-7,200(PRD)	Residential 7,200 sq. ft.	SFR-Basic
14 107757 RK	R-7,200(PRD)	Residential 7,200 sq. ft.	SFR-Basic
14 107764 RK	R-7,200(PRD)	Residential 7,200 sq. ft.	SFR-Basic
14 107758 RK	R-7,200(PRD)	Residential 7,200 sq. ft.	SFR-Basic
14 104093 RK	R-7,200(PRD)	Residential 7,200 sq. ft.	SFR-Basic
14 104092 RK	R-7,200(PRD)	Residential 7,200 sq. ft.	SFR-Basic
14 107761 RK	R-7,200(PRD)	Residential 7,200 sq. ft.	SFR-Basic
14 107762 RK	R-7,200(PRD)	Residential 7,200 sq. ft.	SFR-Basic
14 105030 RK	R-7,200(PRD)	Residential 7,200 sq. ft.	SFR-Basic
14 102228 RK	R-7,200(PRD)	Residential 7,200 sq. ft.	SFR-Basic
14 102229 RK	R-7,200(PRD)	Residential 7,200 sq. ft.	SFR-Basic
14 102230 RK	R-7,200(PRD)	Residential 7,200 sq. ft.	SFR-Basic
14 101125 RK	R-7,200(PRD)	Residential 7,200 sq. ft.	SFR-Basic
14 106822 RK	R-7,200(PRD)	Residential 7,200 sq. ft.	SFR-Basic
14 102231 RK	R-7,200(PRD)	Residential 7,200 sq. ft.	SFR-Basic
14 102232 RK	R-7,200(PRD)	Residential 7,200 sq. ft.	SFR-Basic
14 106823 RK	R-7,200(PRD)	Residential 7,200 sq. ft.	SFR-Basic
14 105451 RK	R-7,200(PRD)	Residential 7,200 sq. ft.	SFR-Basic
14 105452 RK	R-7,200(PRD)	Residential 7,200 sq. ft.	SFR-Basic
14 105453 RK	R-7,200(PRD)	Residential 7,200 sq. ft.	SFR-Basic
14 107724 RK	R-7,200	Residential 7,200 sq. ft.	SFR-Basic
13 115397 RK	R-7,200	Residential 7,200 sq. ft.	SFR-Basic
14 107725 RK	R-7,200	Residential 7,200 sq. ft.	SFR-Basic
14 107726 RK	R-7,200	Residential 7,200 sq. ft.	SFR-Basic
14 114551 RK	R-7,200	Residential 7,200 sq. ft.	SFR-Basic
14 114552 RK	R-7,200	Residential 7,200 sq. ft.	SFR-Basic
14 114553 RK	R-7,200	Residential 7,200 sq. ft.	SFR-Basic
14 104075 RK	R-7,200	Residential 7,200 sq. ft.	SFR-Basic
14 101094 RK	R-7,200	Residential 7,200 sq. ft.	SFR-Basic
14 108802 RK	R-7,200	Residential 7,200 sq. ft.	SFR-Basic
14 111795 RK	R-5	Rural-5 Acre	Single Family Residential
13 113921 RK	R-5	Rural-5 Acre	Single Family Residential
13 114105 RK	R-5	Rural-5 Acre	SFR-Basic
14 101087 RK	R-7,200	Residential 7,200 sq. ft.	SFR-Basic
14 101089 RK	R-7,200	Residential 7,200 sq. ft.	SFR-Basic
14 101091 RK	R-7,200	Residential 7,200 sq. ft.	SFR-Basic
14 101092 RK	R-7,200	Residential 7,200 sq. ft.	SFR-Basic

Accessory Dwelling Units

Index # - File Name: 1.0022 - Single Family Dwellings Data\_Snohomish County.pdf

14 106188 RK	R-7,200	Residential 7,200 sq. ft.	SFR-Basic
14 107660 RK	R-7,200	Residential 7,200 sq. ft.	SFR-Basic
14 107665 RK	R-7,200	Residential 7,200 sq. ft.	SFR-Basic
14 101515 RK	R-7,200	Residential 7,200 sq. ft.	SFR-Basic
14 101514 RK	R-7,200	Residential 7,200 sq. ft.	SFR-Basic
14 113790 RK	R-7,200	Residential 7,200 sq. ft.	SFR-Basic
14 113791 RK	R-7,200	Residential 7,200 sq. ft.	SFR-Basic
13 115531 RK	R-7,200	Residential 7,200 sq. ft.	SFR-Basic
14 103343 RK	R-7,200	Residential 7,200 sq. ft.	SFR-Basic
14 101785 RK	R-7,200	Residential 7,200 sq. ft.	SFR-Basic
14 108496 RK	R-9,600	Residential 9,600 sq. ft.	Single Family Residential
14 108493 RK	R-9,600	Residential 9,600 sq. ft.	Single Family Residential
13 115894 RK	R-7,200	Residential 7,200 sq. ft.	Single Family Residential
13 115895 RK	R-7,200	Residential 7,200 sq. ft.	Single Family Residential
14 100820 RK	R-7,200	Residential 7,200 sq. ft.	SFR-Basic
14 100821 RK	R-7,200	Residential 7,200 sq. ft.	SFR-Basic
14 100822 RK	R-7,200	Residential 7,200 sq. ft.	SFR-Basic
13 110978 RK	R-5	Rural-5 Acre	SFR-Basic
14 101604 RK	R-7,200	Residential 7,200 sq. ft.	SFR-Basic
14 103427 RK	R-7,200	Residential 7,200 sq. ft.	SFR-Basic
14 103428 RK	R-7,200	Residential 7,200 sq. ft.	SFR-Basic
13 115070 RK	R-7,200	Residential 7,200 sq. ft.	SFR-Basic
13 115071 RK	R-7,200	Residential 7,200 sq. ft.	SFR-Basic
14 103103 RK	R-9,600	Residential 9,600 sq. ft.	SFR-Basic
14 103102 RK	R-9,600	Residential 9,600 sq. ft.	SFR-Basic
14 101507 RK	F	Forestry	Single Family Residential
13 115282 RK	R-7,200	Residential 7,200 sq. ft.	SFR-Basic
14 106965 RK	R-7,200	Residential 7,200 sq. ft.	Single Family Residential
14 106966 RK	R-7,200	Residential 7,200 sq. ft.	Single Family Residential
14 106968 RK	R-7,200	Residential 7,200 sq. ft.	Single Family Residential
14 106969 RK	R-7,200	Residential 7,200 sq. ft.	Single Family Residential
14 106970 RK	R-7,200	Residential 7,200 sq. ft.	Single Family Residential
14 106972 RK	R-7,200	Residential 7,200 sq. ft.	Single Family Residential
14 108191 RK	R-7,200	Residential 7,200 sq. ft.	Single Family Residential
14 108194 RK	R-7,200	Residential 7,200 sq. ft.	Single Family Residential
14 108195 RK	R-7,200	Residential 7,200 sq. ft.	Single Family Residential
14 108196 RK	R-7,200	Residential 7,200 sq. ft.	Single Family Residential
14 108612 RK	R-7,200	Residential 7,200 sq. ft.	Single Family Residential
14 108197 RK	R-7,200	Residential 7,200 sq. ft.	Single Family Residential
14 110106 RK	R-7,200	Residential 7,200 sq. ft.	SFR-Basic
14 109848 RK	R-7,200	Residential 7,200 sq. ft.	SFR-Basic
14 105111 RK	R-7,200	Residential 7,200 sq. ft.	SFR-Basic
14 103691 RK	R-7,200	Residential 7,200 sq. ft.	SFR-Basic
14 103692 RK	R-7,200	Residential 7,200 sq. ft.	SFR-Basic
14 102296 RK	R-7,200	Residential 7,200 sq. ft.	SFR-Basic
14 101607 RK	R-7,200	Residential 7,200 sq. ft.	SFR-Basic
13 115275 RK	R-7,200	Residential 7,200 sq. ft.	SFR-Basic

Accessory Dwelling Units

Index # - File Name: 1.0022 - Single Family Dwellings Data\_Snohomish County.pdf

13 115276 RK	R-7,200	Residential 7,200 sq. ft.	SFR-Basic
13 115277 RK	R-7,200	Residential 7,200 sq. ft.	SFR-Basic
14 101608 RK	R-7,200	Residential 7,200 sq. ft.	SFR-Basic
14 101609 RK	R-7,200	Residential 7,200 sq. ft.	SFR-Basic
14 101610 RK	R-7,200	Residential 7,200 sq. ft.	SFR-Basic
13 115278 RK	R-7,200	Residential 7,200 sq. ft.	SFR-Basic
13 115279 RK	R-7,200	Residential 7,200 sq. ft.	SFR-Basic
13 112370 RK	R-7,200	Residential 7,200 sq. ft.	SFR-Basic
13 112371 RK	R-7,200	Residential 7,200 sq. ft.	SFR-Basic
14 100864 RK	R-7,200	Residential 7,200 sq. ft.	SFR-Basic
14 100862 RK	R-7,200	Residential 7,200 sq. ft.	SFR-Basic
13 112364 RK	R-7,200	Residential 7,200 sq. ft.	SFR-Basic
14 100861 RK	R-7,200	Residential 7,200 sq. ft.	SFR-Basic
14 100912 RK	R-7,200	Residential 7,200 sq. ft.	SFR-Basic
14 102348 RK	R-7,200	Residential 7,200 sq. ft.	SFR-Basic
14 102349 RK	R-7,200	Residential 7,200 sq. ft.	SFR-Basic
14 107885 RK	R-7,200	Residential 7,200 sq. ft.	SFR-Basic
14 105259 RK	R-7,200	Residential 7,200 sq. ft.	SFR-Basic
14 105930 RK	R-7,200	Residential 7,200 sq. ft.	SFR-Basic
14 112249 RK	R-7,200	Residential 7,200 sq. ft.	SFR-Basic
14 114024 RK	R-7,200	Residential 7,200 sq. ft.	SFR-Basic
14 115848 RK	R-7,200	Residential 7,200 sq. ft.	SFR-Basic
14 115849 RK	R-7,200	Residential 7,200 sq. ft.	SFR-Basic
14 115850 RK	R-7,200	Residential 7,200 sq. ft.	SFR-Basic
14 113516 RK	R-7,200	Residential 7,200 sq. ft.	SFR-Basic
14 112250 RK	R-7,200	Residential 7,200 sq. ft.	SFR-Basic
14 110107 RK	R-7,200	Residential 7,200 sq. ft.	SFR-Basic
14 106609 RK	R-7,200	Residential 7,200 sq. ft.	Single Family Residential
14 105107 RK	R-7,200	Residential 7,200 sq. ft.	SFR-Basic
14 105108 RK	R-7,200	Residential 7,200 sq. ft.	SFR-Basic
14 105109 RK	R-7,200	Residential 7,200 sq. ft.	SFR-Basic
14 105110 RK	R-7,200	Residential 7,200 sq. ft.	SFR-Basic
14 104737 RK	R-7,200	Residential 7,200 sq. ft.	SFR-Basic
14 104738 RK	R-7,200	Residential 7,200 sq. ft.	SFR-Basic
14 115846 RK	R-7,200	Residential 7,200 sq. ft.	SFR-Basic
14 115847 RK	R-7,200	Residential 7,200 sq. ft.	SFR-Basic
14 110105 RK	R-7,200	Residential 7,200 sq. ft.	SFR-Basic
14 113515 RK	R-7,200	Residential 7,200 sq. ft.	SFR-Basic
14 108231 RK	R-7,200	Residential 7,200 sq. ft.	Single Family Residential
14 108232 RK	R-7,200	Residential 7,200 sq. ft.	Single Family Residential
14 106610 RK	R-7,200	Residential 7,200 sq. ft.	Single Family Residential
14 106612 RK	R-7,200	Residential 7,200 sq. ft.	Single Family Residential
14 104122 RK	R-7,200	Residential 7,200 sq. ft.	Single Family Residential
14 105786 RK	R-7,200	Residential 7,200 sq. ft.	Single Family Residential
14 105787 RK	R-7,200	Residential 7,200 sq. ft.	Single Family Residential
14 103255 RK	R-7,200	Residential 7,200 sq. ft.	Single Family Residential
14 103258 RK	R-7,200	Residential 7,200 sq. ft.	Single Family Residential

Accessory Dwelling Units

Index # - File Name: 1.0022 - Single Family Dwellings Data\_Snohomish County.pdf

14 103687 RK	R-7,200	Residential 7,200 sq. ft.	SFR-Basic
14 103688 RK	R-7,200	Residential 7,200 sq. ft.	SFR-Basic
14 103689 RK	R-7,200	Residential 7,200 sq. ft.	SFR-Basic
14 103690 RK	R-7,200	Residential 7,200 sq. ft.	SFR-Basic
14 102291 RK	R-7,200	Residential 7,200 sq. ft.	SFR-Basic
14 102292 RK	R-7,200	Residential 7,200 sq. ft.	SFR-Basic
14 102293 RK	R-7,200	Residential 7,200 sq. ft.	SFR-Basic
14 102294 RK	R-7,200	Residential 7,200 sq. ft.	SFR-Basic
14 102295 RK	R-7,200	Residential 7,200 sq. ft.	SFR-Basic
14 101605 RK	R-7,200	Residential 7,200 sq. ft.	SFR-Basic
14 101606 RK	R-7,200	Residential 7,200 sq. ft.	SFR-Basic
14 106608 RK	R-7,200	Residential 7,200 sq. ft.	SFR-Basic
14 104121 RK	R-7,200	Residential 7,200 sq. ft.	Single Family Residential
14 110860 RK	R-7,200(PRD)	Residential 7,200 sq. ft.	SFR-Basic
14 110861 RK	R-7,200(PRD)	Residential 7,200 sq. ft.	SFR-Basic
14 110862 RK	R-7,200(PRD)	Residential 7,200 sq. ft.	SFR-Basic
14 110204 RK	R-7,200(PRD)	Residential 7,200 sq. ft.	SFR-Basic
14 110205 RK	R-7,200(PRD)	Residential 7,200 sq. ft.	SFR-Basic
14 110206 RK	R-7,200(PRD)	Residential 7,200 sq. ft.	SFR-Basic
14 107365 RK	R-7,200(PRD)	Residential 7,200 sq. ft.	SFR-Basic
14 107369 RK	R-7,200(PRD)	Residential 7,200 sq. ft.	SFR-Basic
14 107370 RK	R-7,200(PRD)	Residential 7,200 sq. ft.	SFR-Basic
14 116180 RK	R-7,200(PRD)	Residential 7,200 sq. ft.	SFR-Basic
14 105511 RK	R-5	Rural-5 Acre	SFR-Basic
14 103364 RK	R-5	Rural-5 Acre	SFR-Basic
14 106850 RK	R-5	Rural-5 Acre	SFR-Basic
14 106851 RK	R-5	Rural-5 Acre	SFR-Basic
14 105513 RK	R-5	Rural-5 Acre	SFR-Basic
14 103363 RK	R-5	Rural-5 Acre	SFR-Basic
14 105510 RK	R-5	Rural-5 Acre	SFR-Basic
14 112965 RK	R-5	Rural-5 Acre	SFR-Basic
14 106852 RK	R-5	Rural-5 Acre	SFR-Basic
14 100911 RK	R-7,200	Residential 7,200 sq. ft.	SFR-Basic
14 105462 RK	R-9,600	Residential 9,600 sq. ft.	SFR-Basic
14 105463 RK	R-9,600	Residential 9,600 sq. ft.	SFR-Basic
14 105872 RK	R-9,600	Residential 9,600 sq. ft.	SFR-Basic
14 104886 RK	R-9,600	Residential 9,600 sq. ft.	SFR-Basic
14 104885 RK	R-9,600	Residential 9,600 sq. ft.	SFR-Basic
14 100720 RK	R-9,600	Residential 9,600 sq. ft.	SFR-Basic
14 105873 RK	R-9,600	Residential 9,600 sq. ft.	SFR-Basic
14 105465 RK	R-9,600	Residential 9,600 sq. ft.	SFR-Basic
14 105466 RK	R-9,600	Residential 9,600 sq. ft.	SFR-Basic
14 109520 RK	R-9,600	Residential 9,600 sq. ft.	SFR-Basic
14 113556 RK	R-9,600	Residential 9,600 sq. ft.	SFR-Basic
14 115119 RK	R-9,600	Residential 9,600 sq. ft.	SFR-Basic
14 113532 RK	R-9,600	Residential 9,600 sq. ft.	SFR-Basic
14 112465 RK	R-9,600	Residential 9,600 sq. ft.	SFR-Basic

Accessory Dwelling Units

Index # - File Name: 1.0022 - Single Family Dwellings Data\_Snohomish County.pdf

14 109522 RK	R-9,600	Residential 9,600 sq. ft.	SFR-Basic
14 109523 RK	R-9,600	Residential 9,600 sq. ft.	SFR-Basic
14 112466 RK	R-9,600	Residential 9,600 sq. ft.	SFR-Basic
14 106894 RK	R-9,600	Residential 9,600 sq. ft.	SFR-Basic
14 106895 RK	R-9,600	Residential 9,600 sq. ft.	SFR-Basic
14 106896 RK	R-9,600	Residential 9,600 sq. ft.	SFR-Basic
14 105496 RK	R-9,600	Residential 9,600 sq. ft.	SFR-Basic
14 105497 RK	R-9,600	Residential 9,600 sq. ft.	SFR-Basic
14 106897 RK	R-9,600	Residential 9,600 sq. ft.	SFR-Basic
14 110659 RK	R-9,600	Residential 9,600 sq. ft.	SFR-Basic
14 110660 RK	R-9,600	Residential 9,600 sq. ft.	SFR-Basic
14 109521 RK	R-9,600	Residential 9,600 sq. ft.	SFR-Basic
14 105933 RK	R-9,600	Residential 9,600 sq. ft.	SFR-Basic
14 105934 RK	R-9,600	Residential 9,600 sq. ft.	SFR-Basic
14 105877 RK	MR	Multiple Residential	SFR-Basic
14 114313 RK	R-9,600	Residential 9,600 sq. ft.	SFR-Basic
14 114314 RK	R-9,600	Residential 9,600 sq. ft.	SFR-Basic
14 114315 RK	R-9,600	Residential 9,600 sq. ft.	SFR-Basic
14 114316 RK	R-9,600	Residential 9,600 sq. ft.	SFR-Basic
14 114317 RK	R-9,600	Residential 9,600 sq. ft.	SFR-Basic
14 114318 RK	R-9,600	Residential 9,600 sq. ft.	SFR-Basic
14 103096 RK	R-5	Rural-5 Acre	Single Family Residential
14 104039 RK	R-5	Rural-5 Acre	Single Family Residential
14 102832 RK	R-5	Rural-5 Acre	Single Family Residential
14 103097 RK	R-5	Rural-5 Acre	Single Family Residential
14 106596 MH	A-10	Agriculture-10 Acre	Triple Wide
14 107522 RK	R-5	Rural-5 Acre	Single Family Residential
14 106615 RK	R-7,200	Residential 7,200 sq. ft.	Single Family Residential
14 109833 RK	R-7,200	Residential 7,200 sq. ft.	SFR-Basic
14 108230 RK	R-7,200	Residential 7,200 sq. ft.	Single Family Residential
14 107950 RK	R-7,200	Residential 7,200 sq. ft.	SFR-Basic
14 107951 RK	R-7,200	Residential 7,200 sq. ft.	SFR-Basic
14 109834 RK	R-7,200	Residential 7,200 sq. ft.	SFR-Basic
14 114603 RK	R-7,200	Residential 7,200 sq. ft.	SFR-Basic
14 114604 RK	R-7,200	Residential 7,200 sq. ft.	SFR-Basic
14 114605 RK	R-7,200	Residential 7,200 sq. ft.	SFR-Basic
14 110450 RK	R-7,200	Residential 7,200 sq. ft.	SFR-Basic
14 110451 RK	R-7,200	Residential 7,200 sq. ft.	SFR-Basic
14 114606 RK	R-7,200	Residential 7,200 sq. ft.	SFR-Basic
14 115826 RK	R-7,200	Residential 7,200 sq. ft.	SFR-Basic
14 115827 RK	R-7,200	Residential 7,200 sq. ft.	SFR-Basic
14 105102 RK	R-7,200	Residential 7,200 sq. ft.	SFR-Basic
14 105103 RK	R-7,200	Residential 7,200 sq. ft.	SFR-Basic
14 105104 RK	R-7,200	Residential 7,200 sq. ft.	SFR-Basic
14 105105 RK	R-7,200	Residential 7,200 sq. ft.	SFR-Basic
14 105106 RK	R-7,200	Residential 7,200 sq. ft.	SFR-Basic
14 102908 RK	R-7,200	Residential 7,200 sq. ft.	SFR-Basic



Accessory Dwelling Units

Index # - File Name: 1.0022 - Single Family Dwellings Data\_Snohomish County.pdf

14 108457 RK	R-7,200	Residential 7,200 sq. ft.	SFR-Basic
14 108587 RK	R-7,200	Residential 7,200 sq. ft.	SFR-Basic
14 104863 RK	R-5	Rural-5 Acre	Single Family Residential
14 104827 RK	R-5	Rural-5 Acre	Single Family Residential
14 105330 RK	R-5	Rural-5 Acre	Single Family Residential
14 110586 RK	R-7,200(PRD)	Residential 7,200 sq. ft.	SFR-Basic
14 110587 RK	R-7,200(PRD)	Residential 7,200 sq. ft.	SFR-Basic
14 110737 RK	R-7,200(PRD)	Residential 7,200 sq. ft.	SFR-Basic
14 110588 RK	R-7,200(PRD)	Residential 7,200 sq. ft.	SFR-Basic
14 110738 RK	R-7,200(PRD)	Residential 7,200 sq. ft.	SFR-Basic
14 110739 RK	R-7,200(PRD)	Residential 7,200 sq. ft.	SFR-Basic
14 110740 RK	R-7,200(PRD)	Residential 7,200 sq. ft.	SFR-Basic
14 110741 RK	R-7,200(PRD)	Residential 7,200 sq. ft.	SFR-Basic
14 110742 RK	R-7,200(PRD)	Residential 7,200 sq. ft.	SFR-Basic
14 106021 RK	R-5	Rural-5 Acre	Duplex
14 112254 RK	R-7,200(PRD)	Residential 7,200 sq. ft.	SFR-Basic
14 110589 RK	R-7,200(PRD)	Residential 7,200 sq. ft.	SFR-Basic
14 111215 RK	R-7,200	Residential 7,200 sq. ft.	SFR-Basic
14 111216 RK	R-7,200	Residential 7,200 sq. ft.	SFR-Basic
14 111217 RK	R-7,200	Residential 7,200 sq. ft.	SFR-Basic
14 111218 RK	R-7,200	Residential 7,200 sq. ft.	SFR-Basic
14 111219 RK	R-7,200	Residential 7,200 sq. ft.	SFR-Basic
14 111213 RK	R-7,200	Residential 7,200 sq. ft.	SFR-Basic
14 107743 RK	R-7,200	Residential 7,200 sq. ft.	SFR-Basic
14 107744 RK	R-7,200	Residential 7,200 sq. ft.	SFR-Basic
14 107745 RK	R-7,200	Residential 7,200 sq. ft.	SFR-Basic
14 107746 RK	R-7,200	Residential 7,200 sq. ft.	SFR-Basic
14 107747 RK	R-7,200	Residential 7,200 sq. ft.	SFR-Basic
14 107748 RK	R-7,200	Residential 7,200 sq. ft.	SFR-Basic
14 107749 RK	R-7,200	Residential 7,200 sq. ft.	SFR-Basic
14 107750 RK	R-7,200	Residential 7,200 sq. ft.	SFR-Basic
14 107751 RK	R-7,200	Residential 7,200 sq. ft.	SFR-Basic
14 111214 RK	R-7,200	Residential 7,200 sq. ft.	SFR-Basic
14 111788 RK	R-7,200	Residential 7,200 sq. ft.	Single Family Residential
14 106462 RK	A-10	Agriculture-10 Acre	Single Family Residential
14 106700 RK	R-5	Rural-5 Acre	SFR-Basic
14 106698 RK	R-5	Rural-5 Acre	SFR-Basic
14 113413 RK	R-7,200	Residential 7,200 sq. ft.	Single Family Residential
14 110340 RK	R-7,200	Residential 7,200 sq. ft.	Single Family Residential
14 108074 RK	R-7,200	Residential 7,200 sq. ft.	SFR-Basic
14 112605 RK	R-7,200	Residential 7,200 sq. ft.	Single Family Residential
14 107543 RK	R-7,200	Residential 7,200 sq. ft.	SFR-Basic
14 107631 RK	R-5	Rural-5 Acre	Single Family Residential
14 108104 RK	R-5	Rural-5 Acre	Single Family Residential
14 109540 RK	R-5	Rural-5 Acre	Single Family Residential
14 110626 RK	R-9,600	Residential 9,600 sq. ft.	SFR-Basic
14 108155 RK	R-5	Rural-5 Acre	Single Family Residential

Accessory Dwelling Units

Index # - File Name: 1.0022 - Single Family Dwellings Data\_Snohomish County.pdf

13 112373 RK	R-5	Rural-5 Acre	SFR-Basic
14 108175 RK	R-5	Rural-5 Acre	Single Family Residential
14 108859 RK	R-5	Rural-5 Acre	SFR-Basic
14 102027 RK	R-5	Rural-5 Acre	SFR-Basic
14 110563 RK	R-5	Rural-5 Acre	Single Family Residential
14 110568 RK	R-5	Rural-5 Acre	Single Family Residential
13 112372 RK	R-5	Rural-5 Acre	SFR-Basic
14 108176 RK	R-5	Rural-5 Acre	SFR-Basic
14 108174 RK	R-5	Rural-5 Acre	SFR-Basic
14 108173 RK	R-5	Rural-5 Acre	SFR-Basic
13 114812 RK	R-5	Rural-5 Acre	SFR-Basic
13 115880 RK	RRT-10	Rural Resource Transition-10	Single Family Residential
13 115266 RK	LDMR	Low Density Multiple Residence	SFR-Basic
13 107282 RK	R-7,200	Residential 7,200 sq. ft.	SFR-Basic
13 107283 RK	R-7,200	Residential 7,200 sq. ft.	SFR-Basic
13 107284 RK	R-7,200	Residential 7,200 sq. ft.	SFR-Basic
13 107285 RK	R-7,200	Residential 7,200 sq. ft.	SFR-Basic
13 107286 RK	R-7,200	Residential 7,200 sq. ft.	SFR-Basic
13 107287 RK	R-7,200	Residential 7,200 sq. ft.	SFR-Basic
13 107288 RK	R-7,200	Residential 7,200 sq. ft.	SFR-Basic
13 107289 RK	R-7,200	Residential 7,200 sq. ft.	SFR-Basic
13 107290 RK	R-7,200	Residential 7,200 sq. ft.	SFR-Basic
14 103111 RK	R-7,200	Residential 7,200 sq. ft.	SFR-Basic
14 103112 RK	R-7,200	Residential 7,200 sq. ft.	SFR-Basic
14 103113 RK	R-7,200	Residential 7,200 sq. ft.	SFR-Basic
14 103114 RK	R-7,200	Residential 7,200 sq. ft.	SFR-Basic
14 103115 RK	R-7,200	Residential 7,200 sq. ft.	SFR-Basic
14 103116 RK	R-7,200	Residential 7,200 sq. ft.	SFR-Basic
14 103117 RK	R-7,200	Residential 7,200 sq. ft.	SFR-Basic
14 103118 RK	R-7,200	Residential 7,200 sq. ft.	SFR-Basic
14 103119 RK	R-7,200	Residential 7,200 sq. ft.	SFR-Basic
14 103120 RK	R-7,200	Residential 7,200 sq. ft.	SFR-Basic
14 103121 RK	R-7,200	Residential 7,200 sq. ft.	SFR-Basic
14 103122 RK	R-7,200	Residential 7,200 sq. ft.	SFR-Basic
14 103123 RK	R-7,200	Residential 7,200 sq. ft.	SFR-Basic
14 103124 RK	R-7,200	Residential 7,200 sq. ft.	SFR-Basic
14 103125 RK	R-7,200	Residential 7,200 sq. ft.	SFR-Basic
14 103126 RK	R-7,200	Residential 7,200 sq. ft.	SFR-Basic
14 103127 RK	R-7,200	Residential 7,200 sq. ft.	SFR-Basic
14 103128 RK	R-7,200	Residential 7,200 sq. ft.	SFR-Basic
14 103129 RK	R-7,200	Residential 7,200 sq. ft.	SFR-Basic
14 103130 RK	R-7,200	Residential 7,200 sq. ft.	SFR-Basic
14 103131 RK	R-7,200	Residential 7,200 sq. ft.	SFR-Basic
14 103132 RK	R-7,200	Residential 7,200 sq. ft.	SFR-Basic
14 103133 RK	R-7,200	Residential 7,200 sq. ft.	SFR-Basic
14 103134 RK	R-7,200	Residential 7,200 sq. ft.	SFR-Basic
14 103135 RK	R-7,200	Residential 7,200 sq. ft.	SFR-Basic

Accessory Dwelling Units

Index # - File Name: 1.0022 - Single Family Dwellings Data\_Snohomish County.pdf

14 103136 RK	R-7,200	Residential 7,200 sq. ft.	SFR-Basic
13 107291 RK	R-7,200	Residential 7,200 sq. ft.	SFR-Basic
13 107292 RK	R-7,200	Residential 7,200 sq. ft.	SFR-Basic
13 107293 RK	R-7,200	Residential 7,200 sq. ft.	SFR-Basic
13 107294 RK	R-7,200	Residential 7,200 sq. ft.	SFR-Basic
13 107295 RK	R-7,200	Residential 7,200 sq. ft.	SFR-Basic
13 113883 RK	LDMR	Low Density Multiple Reside	SFR-Basic
13 113880 RK	LDMR	Low Density Multiple Reside	SFR-Basic
13 113881 RK	LDMR	Low Density Multiple Reside	SFR-Basic
13 115267 RK	LDMR	Low Density Multiple Reside	SFR-Basic
13 113885 RK	LDMR	Low Density Multiple Reside	SFR-Basic
13 115268 RK	LDMR	Low Density Multiple Reside	SFR-Basic
13 115269 RK	LDMR	Low Density Multiple Reside	SFR-Basic
13 115270 RK	LDMR	Low Density Multiple Reside	SFR-Basic
13 107298 RK	R-7,200	Residential 7,200 sq. ft.	SFR-Basic
13 107299 RK	R-7,200	Residential 7,200 sq. ft.	SFR-Basic
13 107300 RK	R-7,200	Residential 7,200 sq. ft.	SFR-Basic
13 107301 RK	R-7,200	Residential 7,200 sq. ft.	SFR-Basic
14 103137 RK	R-7,200	Residential 7,200 sq. ft.	SFR-Basic
14 103138 RK	R-7,200	Residential 7,200 sq. ft.	SFR-Basic
14 103139 RK	R-7,200	Residential 7,200 sq. ft.	SFR-Basic
13 107302 RK	R-7,200	Residential 7,200 sq. ft.	SFR-Basic
13 107303 RK	R-7,200	Residential 7,200 sq. ft.	SFR-Basic
13 107304 RK	R-7,200	Residential 7,200 sq. ft.	SFR-Basic
13 114664 RK	R-7,200	Residential 7,200 sq. ft.	SFR-Basic
14 102347 RK	R-7,200	Residential 7,200 sq. ft.	SFR-Basic
13 107148 RK	LDMR	Low Density Multiple Reside	SFR-Basic
13 107151 RK	LDMR	Low Density Multiple Reside	SFR-Basic
14 107364 RK	R-7,200	Residential 7,200 sq. ft.	SFR-Basic
14 103744 RK	R-7,200	Residential 7,200 sq. ft.	SFR-Basic
14 102346 RK	R-7,200	Residential 7,200 sq. ft.	SFR-Basic
14 103684 RK	R-7,200	Residential 7,200 sq. ft.	SFR-Basic
13 114661 RK	R-7,200	Residential 7,200 sq. ft.	SFR-Basic
13 114662 RK	R-7,200	Residential 7,200 sq. ft.	SFR-Basic
14 106274 RK	R-7,200	Residential 7,200 sq. ft.	SFR-Basic
14 106182 RK	R-7,200	Residential 7,200 sq. ft.	SFR-Basic
14 105931 RK	R-7,200	Residential 7,200 sq. ft.	SFR-Basic
14 105260 RK	R-7,200	Residential 7,200 sq. ft.	SFR-Basic
14 106275 RK	R-7,200	Residential 7,200 sq. ft.	SFR-Basic
13 115609 RK	R-7,200	Residential 7,200 sq. ft.	SFR-Basic
13 114663 RK	R-7,200	Residential 7,200 sq. ft.	SFR-Basic
13 114006 RK	R-7,200	Residential 7,200 sq. ft.	SFR-Basic
14 104052 RK	R-7,200	Residential 7,200 sq. ft.	SFR-Basic
13 107748 RK	A-10	Agriculture-10 Acre	Single Family Residential
14 102005 RK	R-7,200	Residential 7,200 sq. ft.	SFR-Basic
13 114028 RK	R-7,200	Residential 7,200 sq. ft.	SFR-Basic
14 105261 RK	R-9,600(PRD)	Residential 9,600 sq. ft.	SFR-Basic

Accessory Dwelling Units

Index # - File Name: 1.0022 - Single Family Dwellings Data\_Snohomish County.pdf

14 100945 RK	R-9,600(PRD)	Residential 9,600 sq. ft.	SFR-Basic
14 104727 RK	R-9,600(PRD)	Residential 9,600 sq. ft.	SFR-Basic
14 102939 RK	R-9,600(PRD)	Residential 9,600 sq. ft.	SFR-Basic
14 102940 RK	R-9,600(PRD)	Residential 9,600 sq. ft.	SFR-Basic
14 104728 RK	R-9,600(PRD)	Residential 9,600 sq. ft.	SFR-Basic
14 106178 RK	R-9,600(PRD)	Residential 9,600 sq. ft.	SFR-Basic
14 105262 RK	R-9,600(PRD)	Residential 9,600 sq. ft.	SFR-Basic
14 105263 RK	R-9,600(PRD)	Residential 9,600 sq. ft.	SFR-Basic
14 106874 RK	R-9,600(PRD)	Residential 9,600 sq. ft.	SFR-Basic
14 106875 RK	R-9,600(PRD)	Residential 9,600 sq. ft.	SFR-Basic
14 100946 RK	R-9,600(PRD)	Residential 9,600 sq. ft.	SFR-Basic
14 108008 RK	R-9,600(PRD)	Residential 9,600 sq. ft.	SFR-Basic
13 114290 RK	R-9,600(PRD)	Residential 9,600 sq. ft.	SFR-Basic
13 114289 RK	R-9,600(PRD)	Residential 9,600 sq. ft.	SFR-Basic
13 115287 RK	R-9,600(PRD)	Residential 9,600 sq. ft.	SFR-Basic
13 114291 RK	R-9,600(PRD)	Residential 9,600 sq. ft.	SFR-Basic
14 100947 RK	R-9,600(PRD)	Residential 9,600 sq. ft.	SFR-Basic
14 100948 RK	R-9,600(PRD)	Residential 9,600 sq. ft.	SFR-Basic
14 100949 RK	R-9,600(PRD)	Residential 9,600 sq. ft.	SFR-Basic
14 105264 RK	R-9,600(PRD)	Residential 9,600 sq. ft.	SFR-Basic
14 109554 RK	R-9,600(PRD)	Residential 9,600 sq. ft.	SFR-Basic
14 109316 RK	R-9,600(PRD)	Residential 9,600 sq. ft.	SFR-Basic
14 108087 RK	R-9,600(PRD)	Residential 9,600 sq. ft.	SFR-Basic
14 106898 RK	R-9,600(PRD)	Residential 9,600 sq. ft.	SFR-Basic
14 105935 RK	R-9,600(PRD)	Residential 9,600 sq. ft.	SFR-Basic
14 106899 RK	R-9,600(PRD)	Residential 9,600 sq. ft.	SFR-Basic
14 105936 RK	R-9,600(PRD)	Residential 9,600 sq. ft.	SFR-Basic
14 106900 RK	R-9,600(PRD)	Residential 9,600 sq. ft.	SFR-Basic
14 106901 RK	R-9,600(PRD)	Residential 9,600 sq. ft.	SFR-Basic
14 106902 RK	R-9,600(PRD)	Residential 9,600 sq. ft.	SFR-Basic
14 106903 RK	R-9,600(PRD)	Residential 9,600 sq. ft.	SFR-Basic
14 109317 RK	R-9,600(PRD)	Residential 9,600 sq. ft.	SFR-Basic
14 109318 RK	R-9,600(PRD)	Residential 9,600 sq. ft.	SFR-Basic
14 109555 RK	R-9,600(PRD)	Residential 9,600 sq. ft.	SFR-Basic
14 101462 RK	R-9,600(PRD)	Residential 9,600 sq. ft.	SFR-Basic
14 101463 RK	R-9,600(PRD)	Residential 9,600 sq. ft.	SFR-Basic
14 101464 RK	R-9,600(PRD)	Residential 9,600 sq. ft.	SFR-Basic
14 101465 RK	R-9,600(PRD)	Residential 9,600 sq. ft.	SFR-Basic
14 101466 RK	R-9,600(PRD)	Residential 9,600 sq. ft.	SFR-Basic
14 102560 RK	R-9,600(PRD)	Residential 9,600 sq. ft.	SFR-Basic
14 102561 RK	R-9,600(PRD)	Residential 9,600 sq. ft.	SFR-Basic
14 103697 RK	R-9,600(PRD)	Residential 9,600 sq. ft.	SFR-Basic
14 105937 RK	R-9,600(PRD)	Residential 9,600 sq. ft.	SFR-Basic
14 103698 RK	R-9,600(PRD)	Residential 9,600 sq. ft.	SFR-Basic
14 103699 RK	R-9,600(PRD)	Residential 9,600 sq. ft.	SFR-Basic
14 103384 RK	R-9,600(PRD)	Residential 9,600 sq. ft.	SFR-Basic
14 102563 RK	R-9,600(PRD)	Residential 9,600 sq. ft.	SFR-Basic

Accessory Dwelling Units

Index # - File Name: 1.0022 - Single Family Dwellings Data\_Snohomish County.pdf

14 101467 RK	R-9,600(PRD)	Residential 9,600 sq. ft.	SFR-Basic
14 101468 RK	R-9,600(PRD)	Residential 9,600 sq. ft.	SFR-Basic
13 112561 RK	R-7,200	Residential 7,200 sq. ft.	SFR-Basic
13 112569 RK	R-7,200	Residential 7,200 sq. ft.	SFR-Basic
13 112562 RK	R-7,200	Residential 7,200 sq. ft.	SFR-Basic
14 102006 RK	R-7,200	Residential 7,200 sq. ft.	SFR-Basic
14 102007 RK	R-7,200	Residential 7,200 sq. ft.	SFR-Basic
14 100696 RK	R-7,200	Residential 7,200 sq. ft.	SFR-Basic
14 102004 RK	R-7,200	Residential 7,200 sq. ft.	SFR-Basic
13 115060 RK	R-7,200	Residential 7,200 sq. ft.	SFR-Basic
13 113866 RK	R-7,200	Residential 7,200 sq. ft.	SFR-Basic
14 105898 RK	R-7,200	Residential 7,200 sq. ft.	Single Family Residential
14 111654 RK	R-5	Rural-5 Acre	Single Family Residential
14 109323 RK	R-5	Rural-5 Acre	Single Family Residential
14 109322 RK	R-5	Rural-5 Acre	Single Family Residential
13 107334 RK	R-7,200	Residential 7,200 sq. ft.	SFR-Basic
14 107612 000 01 RK	R-5	Rural-5 Acre	Single Family Residential
13 111903 RK	R-5	Rural-5 Acre	Single Family Residential
13 114966 RK	R-5	Rural-5 Acre	Single Family Residential
14 115326 RK	R-7,200	Residential 7,200 sq. ft.	SFR-Basic
14 106180 RK	R-7,200	Residential 7,200 sq. ft.	SFR-Basic
14 105989 RK	R-7,200	Residential 7,200 sq. ft.	SFR-Basic
14 103681 RK	R-7,200	Residential 7,200 sq. ft.	SFR-Basic
14 104743 RK	R-7,200	Residential 7,200 sq. ft.	SFR-Basic
14 102288 RK	R-7,200	Residential 7,200 sq. ft.	SFR-Basic
14 103105 RK	R-7,200	Residential 7,200 sq. ft.	SFR-Basic
14 105100 RK	R-7,200	Residential 7,200 sq. ft.	SFR-Basic
14 104071 RK	R-7,200	Residential 7,200 sq. ft.	SFR-Basic
14 105928 RK	R-7,200	Residential 7,200 sq. ft.	SFR-Basic
14 106181 RK	R-7,200	Residential 7,200 sq. ft.	SFR-Basic
14 103682 RK	R-7,200	Residential 7,200 sq. ft.	SFR-Basic
14 107363 RK	R-7,200	Residential 7,200 sq. ft.	SFR-Basic
14 102504 RK	R-7,200	Residential 7,200 sq. ft.	SFR-Basic
14 103683 RK	R-7,200	Residential 7,200 sq. ft.	SFR-Basic
14 102188 RK	R-7,200	Residential 7,200 sq. ft.	SFR-Basic
14 113530 RK	R-7,200	Residential 7,200 sq. ft.	SFR-Basic
14 108586 RK	R-7,200	Residential 7,200 sq. ft.	SFR-Basic
14 108265 RK	R-7,200	Residential 7,200 sq. ft.	SFR-Basic
14 105929 RK	R-7,200	Residential 7,200 sq. ft.	SFR-Basic
14 101897 RK	R-7,200	Residential 7,200 sq. ft.	SFR-Basic
14 107889 RK	R-7,200	Residential 7,200 sq. ft.	SFR-Basic
14 108266 RK	R-7,200	Residential 7,200 sq. ft.	SFR-Basic
14 113417 RK	R-7,200	Residential 7,200 sq. ft.	SFR-Basic
14 111725 RK	R-7,200	Residential 7,200 sq. ft.	SFR-Basic
14 108092 RK	R-7,200	Residential 7,200 sq. ft.	SFR-Basic
14 108267 RK	R-7,200	Residential 7,200 sq. ft.	SFR-Basic
14 107583 RK	R-7,200	Residential 7,200 sq. ft.	SFR-Basic

Accessory Dwelling Units

Index # - File Name: 1.0022 - Single Family Dwellings Data\_Snohomish County.pdf

14 109284 RK	R-7,200	Residential 7,200 sq. ft.	SFR-Basic
14 109285 RK	R-7,200	Residential 7,200 sq. ft.	SFR-Basic
14 109286 RK	R-7,200	Residential 7,200 sq. ft.	SFR-Basic
14 109287 RK	R-7,200	Residential 7,200 sq. ft.	SFR-Basic
14 109288 RK	R-7,200	Residential 7,200 sq. ft.	SFR-Basic
14 109289 RK	R-7,200	Residential 7,200 sq. ft.	SFR-Basic
14 109290 RK	R-7,200	Residential 7,200 sq. ft.	SFR-Basic
14 109291 RK	R-7,200	Residential 7,200 sq. ft.	SFR-Basic
13 104752 RK	F	Forestry	SFR-Basic
14 103209 RK	F	Forestry	SFR-Basic
14 103983 RK	F	Forestry	SFR-Basic
13 110067 RK	F	Forestry	Single Family Residential
14 105099 RK	R-7,200	Residential 7,200 sq. ft.	SFR-Basic
13 114520 RK	R-7,200	Residential 7,200 sq. ft.	SFR-Basic
13 115260 RK	R-7,200	Residential 7,200 sq. ft.	SFR-Basic
13 115261 RK	R-7,200	Residential 7,200 sq. ft.	SFR-Basic
14 101611 RK	R-7,200	Residential 7,200 sq. ft.	SFR-Basic
13 115608 RK	R-7,200	Residential 7,200 sq. ft.	SFR-Basic
13 114003 RK	R-7,200	Residential 7,200 sq. ft.	SFR-Basic
13 114004 RK	R-7,200	Residential 7,200 sq. ft.	SFR-Basic
13 114005 RK	R-7,200	Residential 7,200 sq. ft.	SFR-Basic
12 107718 RK	R-5	Rural-5 Acre	Single Family Residential
14 114111 RK	R-7,200	Residential 7,200 sq. ft.	SFR-Basic
14 114114 RK	R-7,200	Residential 7,200 sq. ft.	SFR-Basic
14 114115 RK	R-7,200	Residential 7,200 sq. ft.	SFR-Basic
14 114117 RK	R-7,200	Residential 7,200 sq. ft.	SFR-Basic
14 114119 RK	R-7,200	Residential 7,200 sq. ft.	SFR-Basic
14 114294 RK	R-7,200	Residential 7,200 sq. ft.	SFR-Basic
14 114295 RK	R-7,200	Residential 7,200 sq. ft.	SFR-Basic
14 114296 RK	R-7,200	Residential 7,200 sq. ft.	SFR-Basic
14 114297 RK	R-7,200	Residential 7,200 sq. ft.	SFR-Basic
14 114298 RK	R-7,200	Residential 7,200 sq. ft.	SFR-Basic
14 114299 RK	R-7,200	Residential 7,200 sq. ft.	SFR-Basic
14 116105 RK	R-7,200	Residential 7,200 sq. ft.	SFR-Basic
14 116106 RK	R-7,200	Residential 7,200 sq. ft.	SFR-Basic
14 116107 RK	R-7,200	Residential 7,200 sq. ft.	SFR-Basic
14 116108 RK	R-7,200	Residential 7,200 sq. ft.	SFR-Basic
14 114290 RK	R-7,200	Residential 7,200 sq. ft.	SFR-Basic
14 114291 RK	R-7,200	Residential 7,200 sq. ft.	SFR-Basic
14 114292 RK	R-7,200	Residential 7,200 sq. ft.	SFR-Basic
14 114293 RK	R-7,200	Residential 7,200 sq. ft.	SFR-Basic
14 116104 RK	R-7,200	Residential 7,200 sq. ft.	SFR-Basic
14 108526 RK	R-5	Rural-5 Acre	Single Family Residential
14 109108 RK	R-5	Rural-5 Acre	Single Family Residential
14 110126 MH	R-5	Rural-5 Acre	Double Wide
14 111657 MH	R-12,500	Residential 12,500 sq. ft.	Double Wide
14 111131 RK	A-10	Agriculture-10 Acre	Single Family Residential

Accessory Dwelling Units

Index # - File Name: 1.0022 - Single Family Dwellings Data\_Snohomish County.pdf

14 110595 RK	R-7,200	Residential 7,200 sq. ft.	Single Family Residential
14 113781 RK	R-7,200	Residential 7,200 sq. ft.	Single Family Residential
14 113782 RK	R-7,200	Residential 7,200 sq. ft.	Single Family Residential
14 113783 RK	R-7,200	Residential 7,200 sq. ft.	Single Family Residential
14 114574 RK	R-7,200	Residential 7,200 sq. ft.	Single Family Residential
14 110809 RK	MR	Multiple Residential	SFR-Basic
14 112425 RK	R-5	Rural-5 Acre	Single Family Residential
14 112499 RK	R-5	Rural-5 Acre	Single Family Residential
14 111287 RK	R-5	Rural-5 Acre	Single Family Residential
14 113291 RK	R-5	Rural-5 Acre	Single Family Residential
14 111822 RK	R-5	Rural-5 Acre	Single Family Residential
14 112097 RK	R-7,200	Residential 7,200 sq. ft.	SFR-Basic
14 113177 000 01 RK	LDMR	Low Density Multiple Reside	SFR-Basic
14 111525 RK	R-5	Rural-5 Acre	Single Family Residential
14 112507 RK	R-7,200	Residential 7,200 sq. ft.	SFR-Basic
14 115327 RK	R-7,200	Residential 7,200 sq. ft.	SFR-Basic
14 115328 RK	R-7,200	Residential 7,200 sq. ft.	SFR-Basic
14 115331 RK	R-7,200	Residential 7,200 sq. ft.	SFR-Basic
14 115332 RK	R-7,200	Residential 7,200 sq. ft.	SFR-Basic
14 109095 RK	R-5	Rural-5 Acre	Single Family Residential
14 108492 RK	R-9,600	Residential 9,600 sq. ft.	SFR-Basic
13 114106 RK	R-5	Rural-5 Acre	Single Family Residential
14 104927 RK	R-7,200(PRD)	Residential 7,200 sq. ft.	SFR-Basic
13 115336 RK	R-5	Rural-5 Acre	Single Family Residential
14 104055 RK	R-7,200(PRD)	Residential 7,200 sq. ft.	SFR-Basic
14 109113 RK	R-7,200(PRD)	Residential 7,200 sq. ft.	SFR-Basic
14 109380 RK	R-7,200(PRD)	Residential 7,200 sq. ft.	SFR-Basic
14 104053 RK	R-7,200(PRD)	Residential 7,200 sq. ft.	SFR-Basic
13 115610 RK	R-7,200(PRD)	Residential 7,200 sq. ft.	SFR-Basic
14 109381 RK	R-7,200(PRD)	Residential 7,200 sq. ft.	SFR-Basic
14 106871 RK	R-7,200(PRD)	Residential 7,200 sq. ft.	SFR-Basic
14 103106 RK	R-7,200(PRD)	Residential 7,200 sq. ft.	SFR-Basic
14 106872 RK	R-7,200(PRD)	Residential 7,200 sq. ft.	SFR-Basic
14 103685 RK	R-7,200(PRD)	Residential 7,200 sq. ft.	SFR-Basic
14 107886 RK	R-7,200(PRD)	Residential 7,200 sq. ft.	SFR-Basic
13 114007 RK	R-7,200(PRD)	Residential 7,200 sq. ft.	SFR-Basic
14 102289 RK	R-7,200(PRD)	Residential 7,200 sq. ft.	SFR-Basic
14 101765 RK	R-7,200(PRD)	Residential 7,200 sq. ft.	SFR-Basic
13 114420 RK	R-7,200(PRD)	Residential 7,200 sq. ft.	SFR-Basic
13 114422 RK	R-7,200(PRD)	Residential 7,200 sq. ft.	SFR-Basic
13 114521 RK	R-7,200(PRD)	Residential 7,200 sq. ft.	SFR-Basic
14 104054 RK	R-7,200(PRD)	Residential 7,200 sq. ft.	SFR-Basic
13 115611 RK	R-7,200(PRD)	Residential 7,200 sq. ft.	SFR-Basic
14 104760 RK	RD	Rural Diversification	Single Family Residential
14 103107 RK	R-7,200(PRD)	Residential 7,200 sq. ft.	SFR-Basic
14 106201 RK	R-7,200(PRD)	Residential 7,200 sq. ft.	SFR-Basic
14 104929 RK	R-7,200(PRD)	Residential 7,200 sq. ft.	SFR-Basic

Accessory Dwelling Units

Index # - File Name: 1.0022 - Single Family Dwellings Data\_Snohomish County.pdf

13 115395 RK	R-5	Rural-5 Acre	Single Family Residential
14 109450 RK	R-5	Rural-5 Acre	SFR-Basic
14 105828 RK	R-5	Rural-5 Acre	Single Family Residential
14 108099 RK	A-10	Agriculture-10 Acre	Single Family Residential
14 109868 000 01 RK	R-5	Rural-5 Acre	Single Family Residential
14 107602 RK	R-5	Rural-5 Acre	SFR-Basic
14 107603 RK	R-5	Rural-5 Acre	SFR-Basic
14 107709 RK	R-5	Rural-5 Acre	SFR-Basic
14 107599 RK	R-5	Rural-5 Acre	SFR-Basic
14 107600 RK	R-5	Rural-5 Acre	SFR-Basic
14 107601 RK	R-5	Rural-5 Acre	SFR-Basic
14 107597 RK	R-5	Rural-5 Acre	SFR-Basic
14 109627 RK	R-7,200	Residential 7,200 sq. ft.	SFR-Basic
14 106416 RK	R-5	Rural-5 Acre	SFR-Basic
14 100453 RK	R-5	Rural-5 Acre	Single Family Residential
14 100452 RK	R-5	Rural-5 Acre	Single Family Residential
14 106150 RK	PRD-7,200	Residential 7,200 sq. ft.	Single Family Residential
14 101411 RK	R-5	Rural-5 Acre	Single Family Residential
14 114303 RK	R-7,200	Residential 7,200 sq. ft.	SFR-Basic
14 114005 RK	R-7,200	Residential 7,200 sq. ft.	SFR-Basic
14 111587 RK	R-7,200	Residential 7,200 sq. ft.	SFR-Basic
14 114306 RK	R-7,200	Residential 7,200 sq. ft.	SFR-Basic
14 114307 RK	R-7,200	Residential 7,200 sq. ft.	SFR-Basic
14 104935 RK	R-7,200	Residential 7,200 sq. ft.	SFR-Basic
14 104936 RK	R-7,200	Residential 7,200 sq. ft.	SFR-Basic
14 107542 RK	R-7,200	Residential 7,200 sq. ft.	SFR-Basic
14 108667 RK	R-7,200	Residential 7,200 sq. ft.	SFR-Basic
14 112362 RK	R-7,200	Residential 7,200 sq. ft.	SFR-Basic
14 109626 RK	R-7,200	Residential 7,200 sq. ft.	SFR-Basic
13 107357 RK	LDMR	Low Density Multiple Reside	SFR-Basic
13 107358 RK	LDMR	Low Density Multiple Reside	SFR-Basic
13 107359 RK	LDMR	Low Density Multiple Reside	SFR-Basic
13 107360 RK	LDMR	Low Density Multiple Reside	SFR-Basic
13 107361 RK	LDMR	Low Density Multiple Reside	SFR-Basic
13 107362 RK	LDMR	Low Density Multiple Reside	SFR-Basic
13 107363 RK	LDMR	Low Density Multiple Reside	SFR-Basic
13 107364 RK	LDMR	Low Density Multiple Reside	SFR-Basic
13 107365 RK	LDMR	Low Density Multiple Reside	SFR-Basic
13 107366 RK	LDMR	Low Density Multiple Reside	SFR-Basic
13 107367 RK	LDMR	Low Density Multiple Reside	SFR-Basic
13 107368 RK	LDMR	Low Density Multiple Reside	SFR-Basic
13 107369 RK	LDMR	Low Density Multiple Reside	SFR-Basic
13 107352 RK	LDMR	Low Density Multiple Reside	SFR-Basic
13 113554 000 01 RK	R-5	Rural-5 Acre	Single Family Residential
12 111041 RK	LDMR	Low Density Multiple Reside	SFR-Basic
12 111042 RK	LDMR	Low Density Multiple Reside	SFR-Basic
12 111048 RK	LDMR	Low Density Multiple Reside	SFR-Basic



Accessory Dwelling Units

Index # - File Name: 1.0022 - Single Family Dwellings Data\_Snohomish County.pdf

13 112379 RK	LDMR	Low Density Multiple Reside Duplex	
12 111045 RK	LDMR	Low Density Multiple Reside SFR-Basic	
13 107149 RK	LDMR	Low Density Multiple Reside SFR-Basic	
12 111047 RK	LDMR	Low Density Multiple Reside SFR-Basic	
12 111312 RK	LDMR	Low Density Multiple Reside SFR-Basic	
12 111313 RK	LDMR	Low Density Multiple Reside SFR-Basic	
12 111314 RK	LDMR	Low Density Multiple Reside SFR-Basic	
13 107147 RK	LDMR	Low Density Multiple Reside SFR-Basic	
12 111315 RK	LDMR	Low Density Multiple Reside SFR-Basic	
12 111316 RK	LDMR	Low Density Multiple Reside SFR-Basic	
12 111317 RK	LDMR	Low Density Multiple Reside SFR-Basic	
12 111318 RK	LDMR	Low Density Multiple Reside SFR-Basic	
12 111319 RK	LDMR	Low Density Multiple Reside SFR-Basic	
12 111320 RK	LDMR	Low Density Multiple Reside SFR-Basic	
12 111321 RK	LDMR	Low Density Multiple Reside SFR-Basic	
14 113287 RK	R-7,200	Residential 7,200 sq. ft.	Single Family Residential
14 113286 RK	R-7,200	Residential 7,200 sq. ft.	Single Family Residential
14 113284 RK	R-7,200	Residential 7,200 sq. ft.	Single Family Residential
13 107614 RK	R-5	Rural-5 Acre	Single Family Residential
14 111330 RK	R-5	Rural-5 Acre	Single Family Residential
13 107021 RK	R-5	Rural-5 Acre	SFR-Basic
13 107025 RK	R-5	Rural-5 Acre	Single Family Residential
13 107026 RK	R-5	Rural-5 Acre	Single Family Residential
13 107029 RK	R-5	Rural-5 Acre	SFR-Basic
13 107031 RK	R-5	Rural-5 Acre	SFR-Basic
13 107032 RK	R-5	Rural-5 Acre	SFR-Basic
13 107033 RK	R-5	Rural-5 Acre	Single Family Residential
13 107036 RK	R-5	Rural-5 Acre	Single Family Residential
13 107039 RK	R-5	Rural-5 Acre	SFR-Basic
13 107040 RK	R-5	Rural-5 Acre	Single Family Residential
13 110817 RK	R-5	Rural-5 Acre	Single Family Residential
14 102305 RK	R-7,200	Residential 7,200 sq. ft.	Single Family Residential
14 107851 RK	MR	Multiple Residential	Single Family Residential
14 102212 RK	R-5	Rural-5 Acre	Single Family Residential
13 114967 RK	R-5	Rural-5 Acre	Single Family Residential
13 111842 RK	R-5	Rural-5 Acre	Single Family Residential
13 114561 RK	F	Forestry	SFR-Basic
13 114563 RK	F	Forestry	SFR-Basic
14 106964 RK	F	Forestry	Single Family Residential
14 110718 RK	R-5	Rural-5 Acre	Single Family Residential
14 103371 RK	R-5	Rural-5 Acre	Single Family Residential
13 113927 RK	A-10 : CITY : R-	Agriculture-10 Acre : City : R	Single Family Residential
14 104812 RK	R-5	Rural-5 Acre	Single Family Residential
14 103051 RK	R-5	Rural-5 Acre	Single Family Residential
13 112668 RK	MR	Multiple Residential	SFR-Basic
13 112667 RK	MR	Multiple Residential	SFR-Basic
13 115326 RK	R-5	Rural-5 Acre	Single Family Residential

Accessory Dwelling Units

Index # - File Name: 1.0022 - Single Family Dwellings Data\_Snohomish County.pdf

13 115805 RK	A-10	Agriculture-10 Acre	Single Family Residential
14 102081 RK	A-10	Agriculture-10 Acre	Single Family Residential
14 101964 RK	R-5	Rural-5 Acre	Single Family Residential
14 109908 RK	R-5	Rural-5 Acre	Single Family Residential
14 107345 RK	R-5	Rural-5 Acre	Single Family Residential
11 107419 MH	R-5	Rural-5 Acre	Double Wide
14 102352 RK	R-7,200	Residential 7,200 sq. ft.	Single Family Residential
14 102331 RK	R-5	Rural-5 Acre	Single Family Residential
14 110269 RK	A-10	Agriculture-10 Acre	Single Family Residential
13 114086 RK	A-10 : R-5	Agriculture-10 Acre : Rural-5	Single Family Residential
14 103416 RK	R-5	Rural-5 Acre	Single Family Residential
14 107783 RK	R-5	Rural-5 Acre	Accessory Apt Detached
14 111603 RK	R-5	Rural-5 Acre	Single Family Residential
12 105579 RK	R-5	Rural-5 Acre	Single Family Residential
14 106809 RK	R-5	Rural-5 Acre	Single Family Residential
14 103623 RK	F	Forestry	Single Family Residential
14 108184 000 01 RK	F	Forestry	Single Family Residential
13 107774 RK	F	Forestry	Single Family Residential
13 106172 RK	R-5	Rural-5 Acre	Single Family Residential
14 106919 RK	R-5	Rural-5 Acre	Single Family Residential
14 105800 RK	R-5	Rural-5 Acre	Single Family Residential
14 102340 RK	A-10	Agriculture-10 Acre	Single Family Residential
13 115814 RK	R-5	Rural-5 Acre	Single Family Residential
14 103198 RK	R-5	Rural-5 Acre	Single Family Residential
14 101361 RK	R-5	Rural-5 Acre	SFR-Basic
14 112961 RK	R-5	Rural-5 Acre	SFR-Basic
14 101363 RK	R-5	Rural-5 Acre	SFR-Basic
14 101368 000 01 RK	R-5	Rural-5 Acre	SFR-Basic
14 101370 000 01 RK	R-5	Rural-5 Acre	SFR-Basic
14 108688 RK	R-5	Rural-5 Acre	SFR-Basic
14 101371 RK	R-5	Rural-5 Acre	SFR-Basic
14 112960 RK	R-5	Rural-5 Acre	SFR-Basic
14 101369 RK	R-5	Rural-5 Acre	SFR-Basic
13 114548 RK	R-5	Rural-5 Acre	Single Family Residential
13 114545 RK	R-5	Rural-5 Acre	Single Family Residential
13 114544 RK	R-5	Rural-5 Acre	Single Family Residential
14 105932 RK	R-5	Rural-5 Acre	Single Family Residential
14 106713 RK	R-5	Rural-5 Acre	Single Family Residential
14 106711 RK	R-5	Rural-5 Acre	Single Family Residential
14 110071 RK	R-5	Rural-5 Acre	Single Family Residential
14 112056 RK	R-5	Rural-5 Acre	Single Family Residential
13 111605 MH	R-5 : RC	Rural Conservation : Rural-5	Double Wide
14 111600 RK	RRT-10	Rural Resource Transition-10	Single Family Residential
14 104059 RK	R-5	Rural-5 Acre	Single Family Residential
13 114863 RK	R-5	Rural-5 Acre	Single Family Residential
14 107568 RK	R-5	Rural-5 Acre	Single Family Residential
14 108703 RK	R-9,600	Residential 9,600 sq. ft.	Single Family Residential

Accessory Dwelling Units

Index # - File Name: 1.0022 - Single Family Dwellings Data\_Snohomish County.pdf

13 107086 RK	PRD-7,200	Residential 7,200 sq. ft.	Single Family Residential
13 107087 RK	PRD-7,200	Residential 7,200 sq. ft.	Single Family Residential
14 105735 RK	R-5	Rural-5 Acre	Single Family Residential
14 100730 000 01 RK	R-5	Rural-5 Acre	Single Family Residential
14 107442 RK	R-5	Rural-5 Acre	Single Family Residential
14 105217 RK	R-9,600	Residential 9,600 sq. ft.	Single Family Residential
14 105219 RK	R-9,600	Residential 9,600 sq. ft.	Single Family Residential
14 102215 000 01 RK	R-5	Rural-5 Acre	Single Family Residential
14 107494 000 01 RK	R-5	Rural-5 Acre	Single Family Residential
12 104330 RK	R-5	Rural-5 Acre	Single Family Residential
14 103042 RK	R-5	Rural-5 Acre	Single Family Residential
14 105047 RK	R-5	Rural-5 Acre	SFR-Basic
14 103962 RK	F	Forestry	Single Family Residential
14 105327 RK	R-5	Rural-5 Acre	Single Family Residential
14 104133 RK	R-5	Rural-5 Acre	Single Family Residential
13 114014 RK	R-5	Rural-5 Acre	Single Family Residential
14 101217 RK	R-5	Rural-5 Acre	Single Family Residential
14 103374 RK	R-5	Rural-5 Acre	Single Family Residential
14 100733 RK	R-5	Rural-5 Acre	Single Family Residential
13 114805 MH	R-5	Rural-5 Acre	Double Wide
14 111418 RK	R-5	Rural-5 Acre	Single Family Residential
14 104762 RK	R-5	Rural-5 Acre	Single Family Residential
14 111044 RK	R-9,600	Residential 9,600 sq. ft.	SFR-Basic
14 110624 RK	R-9,600	Residential 9,600 sq. ft.	SFR-Basic
14 110661 RK	R-8,400	Residential 8,400 sq. ft.	Single Family Residential
14 107403 RK	R-5	Rural-5 Acre	Single Family Residential
14 106769 RK	R-5	Rural-5 Acre	Single Family Residential
14 100890 RK	R-9,600	Residential 9,600 sq. ft.	Accessory Apt Detached
13 115809 RK	R-5	Rural-5 Acre	Single Family Residential
14 106403 RK	F	Forestry	SFR-Basic
14 105325 RK	R-5	Rural-5 Acre	Single Family Residential
14 112030 RK	R-5	Rural-5 Acre	Single Family Residential
14 100851 RK	R-5	Rural-5 Acre	Single Family Residential
14 103635 RK	R-5	Rural-5 Acre	Single Family Residential
14 113537 RK	R-5	Rural-5 Acre	Single Family Residential
14 104948 RK	R-5	Rural-5 Acre	Single Family Residential
14 106224 RK	MR	Multiple Residential	Duplex
14 106949 RK	R-9,600	Residential 9,600 sq. ft.	Single Family Residential
14 111200 RK	R-7,200	Residential 7,200 sq. ft.	Single Family Residential
14 101450 RK	A-10	Agriculture-10 Acre	Single Family Residential
14 105827 RK	R-9,600	Residential 9,600 sq. ft.	Single Family Residential
14 104035 RK	R-5	Rural-5 Acre	Single Family Residential
13 114142 RK	R-5	Rural-5 Acre	Single Family Residential
13 114140 RK	R-5	Rural-5 Acre	Single Family Residential
14 103210 MH	R-5	Rural-5 Acre	Double Wide
14 109416 RK	R-5	Rural-5 Acre	Single Family Residential
13 113649 RK	R-7,200	Residential 7,200 sq. ft.	Single Family Residential

Accessory Dwelling Units

Index # - File Name: 1.0022 - Single Family Dwellings Data\_Snohomish County.pdf

14 110529 RK	R-5	Rural-5 Acre	Single Family Residential
14 105236 RK	R-5	Rural-5 Acre	Single Family Residential
13 107535 RK	R-5	Rural-5 Acre	Single Family Residential
13 115537 RK	R-5	Rural-5 Acre	Single Family Residential
14 113294 RK	R-5	Rural-5 Acre	Single Family Residential
14 114135 RK	R-5	Rural-5 Acre	Single Family Residential
14 108466 RK	R-5	Rural-5 Acre	Single Family Residential
14 113689 RK	R-5	Rural-5 Acre	SFR-Basic
14 111234 RK	R-5	Rural-5 Acre	Single Family Residential
14 109338 RK	R-5	Rural-5 Acre	Single Family Residential
14 108645 RK	R-5	Rural-5 Acre	Single Family Residential
14 107566 RK	F	Forestry	SFR-Basic
14 114327 RK	R-5	Rural-5 Acre	SFR-Basic
14 108185 RK	R-9,600	Residential 9,600 sq. ft.	Single Family Residential
14 108346 RK	WFB	Waterfront Beach	Single Family Residential
14 100790 RK	R-5	Rural-5 Acre	Single Family Residential
12 106208 RK	WFB	Waterfront Beach	Single Family Residential
14 103621 RK	R-7,200	Residential 7,200 sq. ft.	Single Family Residential
14 113297 RK	R-7,200	Residential 7,200 sq. ft.	Duplex
14 108326 RK	R-5	Rural-5 Acre	Single Family Residential
13 115303 RK	RRT-10	Rural Resource Transition-10	Single Family Residential
14 102570 RK	R-5	Rural-5 Acre	Single Family Residential
14 108007 RK	A-10	Agriculture-10 Acre	Single Family Residential
13 113936 RK	R-5	Rural-5 Acre	Single Family Residential
14 100526 RK	R-5	Rural-5 Acre	Single Family Residential
14 108529 RK	R-5	Rural-5 Acre	Single Family Residential
14 103502 RK	R-5	Rural-5 Acre	Single Family Residential
14 106760 RK	R-5	Rural-5 Acre	SFR-Basic
14 110076 RK	R-5	Rural-5 Acre	Single Family Residential
14 106018 MH	RRT-10	Rural Resource Transition-10	Double Wide
13 114935 RK	R-5	Rural-5 Acre	Single Family Residential
13 114074 RK	SA-1	Suburban Agriculture-1 Acre	Single Family Residential
13 114078 RK	SA-1	Suburban Agriculture-1 Acre	Single Family Residential
14 113640 RK	RRT-10	Rural Resource Transition-10	Single Family Residential
14 108744 RK	R-5	Rural-5 Acre	Single Family Residential
13 115535 RK	R-5	Rural-5 Acre	Single Family Residential
14 100961 MH	R-5	Rural-5 Acre	Single Wide
14 112231 RK	R-5	Rural-5 Acre	Single Family Residential
14 112197 RK	R-5	Rural-5 Acre	Single Family Residential
14 113538 MH	R-5	Rural-5 Acre	Double Wide
14 110273 MH	R-5	Rural-5 Acre	Double Wide
13 112050 RK	R-5	Rural-5 Acre	Single Family Residential
14 113557 RK	R-5	Rural-5 Acre	Single Family Residential
13 111330 RK	R-5	Rural-5 Acre	Single Family Residential
14 103299 RK	R-5	Rural-5 Acre	Single Family Residential
14 109936 RK	R-5	Rural-5 Acre	Single Family Residential
14 108447 RK	R-5	Rural-5 Acre	Single Family Residential

Accessory Dwelling Units

Index # - File Name: 1.0022 - Single Family Dwellings Data\_Snohomish County.pdf

14 110102 RK	R-5	Rural-5 Acre	Single Family Residential
14 101377 RK	R-5	Rural-5 Acre	SFR-Basic
14 111570 RK	R-5	Rural-5 Acre	Single Family Residential
14 103679 RK	R-5	Rural-5 Acre	Single Family Residential
14 102569 RK	R-5	Rural-5 Acre	Single Family Residential
14 106194 RK	R-5	Rural-5 Acre	Single Family Residential
13 111857 RK	R-5	Rural-5 Acre	Single Family Residential
14 100401 RK	RD	Rural Diversification	Single Family Residential
14 106672 000 01 RK	R-5	Rural-5 Acre	Single Family Residential
14 108294 RK	R-5	Rural-5 Acre	Single Family Residential
14 102453 RK	R-5	Rural-5 Acre	Single Family Residential
14 104171 RK	R-5	Rural-5 Acre	Single Family Residential
14 106183 000 01 RK	R-5	Rural-5 Acre	Single Family Residential
13 113832 RK	R-5	Rural-5 Acre	Single Family Residential
14 110072 RK	R-5	Rural-5 Acre	Single Family Residential
13 109836 000 01 RK	MR	Multiple Residential	Accessory Apt Detached
14 102856 MH	MHP	Mobile Home Park	MH Park-Double Wide
14 108572 RK	R-5	Rural-5 Acre	Single Family Residential
14 111052 RK	R-9,600	Residential 9,600 sq. ft.	SFR-Basic
14 110644 RK	R-5	Rural-5 Acre	Single Family Residential
14 105756 RK	R-5 : RC	Rural Conservation : Rural-5	Single Family Residential
14 110479 RK	R-5	Rural-5 Acre	Accessory Apt Detached
13 113515 RK	R-5	Rural-5 Acre	Single Family Residential
13 111771 RK	R-5	Rural-5 Acre	Single Family Residential
13 112746 RK	R-5	Rural-5 Acre	Single Family Residential
13 112748 RK	R-5	Rural-5 Acre	Single Family Residential
14 101375 RK	R-5	Rural-5 Acre	SFR-Basic
14 105094 RK	R-5	Rural-5 Acre	Single Family Residential
13 114709 RK	R-5	Rural-5 Acre	Single Family Residential
13 115746 RK	R-5	Rural-5 Acre	Single Family Residential
14 113589 RK	RC	Rural Conservation	Single Family Residential
14 107902 RK	RC	Rural Conservation	Single Family Residential
14 101815 RK	R-5	Rural-5 Acre	Single Family Residential
14 114198 RK	R-5	Rural-5 Acre	SFR-Basic
14 103181 RK	R-5	Rural-5 Acre	Single Family Residential
14 105043 RK	R-5	Rural-5 Acre	Single Family Residential
14 106951 RK	R-9,600	Residential 9,600 sq. ft.	Single Family Residential
15 107763 RK	R-5	Rural-5 Acre	Single Family Residential
15 102931 RK	R-5	Rural-5 Acre	Single Family Residential
15 103856 RK	R-5	Rural-5 Acre	Single Family Residential
15 109051 RK	R-5	Rural-5 Acre	Single Family Residential
15 109309 RK	R-5	Rural-5 Acre	SFR-Basic
15 105768 RK	R-5	Rural-5 Acre	Single Family Residential
15 100517 RK	R-5	Rural-5 Acre	Single Family Residential
15 102491 RK	R-5	Rural-5 Acre	Single Family Residential
15 115502 RK	F	Forestry	Single Family Residential
14 113988 RK	R-5	Rural-5 Acre	Single Family Residential

Accessory Dwelling Units

Index # - File Name: 1.0022 - Single Family Dwellings Data\_Snohomish County.pdf

15 108877 MH	R-5	Rural-5 Acre	Double Wide
15 105536 RK	R-5	Rural-5 Acre	Single Family Residential
15 117224 MH	R-5	Rural-5 Acre	Double Wide
15 107294 MH	R-5	Rural-5 Acre	Double Wide
15 109724 RK	R-5	Rural-5 Acre	Single Family Residential
14 113414 RK	R-5	Rural-5 Acre	SFR-Basic
15 112824 RK	R-5	Rural-5 Acre	Single Family Residential
15 106783 RK	R-5	Rural-5 Acre	Single Family Residential
14 115630 RK	R-5	Rural-5 Acre	Single Family Residential
14 111001 MH	R-5	Rural-5 Acre	Double Wide
15 115133 RK	R-5	Rural-5 Acre	Single Family Residential
15 106233 RK	R-5	Rural-5 Acre	Single Family Residential
15 100823 RK	R-5	Rural-5 Acre	Single Family Residential
15 113497 RK	R-5	Rural-5 Acre	Single Family Residential
15 115618 RK	R-5	Rural-5 Acre	Single Family Residential
14 109641 000 01 RK	R-5	Rural-5 Acre	Single Family Residential
14 115176 RK	R-5	Rural-5 Acre	SFR-Basic
15 106022 MH	R-5	Rural-5 Acre	Double Wide
15 101174 RK	R-5	Rural-5 Acre	SFR-Basic
14 105317 RK	R-5	Rural-5 Acre	SFR-Basic
14 113562 000 01 RK	R-5	Rural-5 Acre	Single Family Residential
15 106751 MH	R-5	Rural-5 Acre	Single Wide
14 116236 000 01 RK	R-5	Rural-5 Acre	Single Family Residential
15 109419 MH	R-5	Rural-5 Acre	Double Wide
15 106187 RK	R-5	Rural-5 Acre	Single Family Residential
15 102622 RK	R-5	Rural-5 Acre	Single Family Residential
15 106062 RK	RRT-10	Rural Resource Transition-10	Single Family Residential
15 105243 000 01 RK	RRT-10	Rural Resource Transition-10	Single Family Residential
15 113880 RK	R-5	Rural-5 Acre	Single Family Residential
15 107283 RK	R-5	Rural-5 Acre	SFR-Basic
15 102327 000 01 RK	R-5	Rural-5 Acre	Single Family Residential
15 110271 RK	R-5	Rural-5 Acre	Single Family Residential
15 103771 000 01 RK	R-5	Rural-5 Acre	Single Family Residential
15 101472 RK	R-5	Rural-5 Acre	Single Family Residential
15 103589 RK	R-5	Rural-5 Acre	Single Family Residential
15 103623 RK	R-5	Rural-5 Acre	Single Family Residential
15 105551 RK	R-5	Rural-5 Acre	Single Family Residential
14 114483 RK	RRT-10	Rural Resource Transition-10	SFR-Basic
15 112817 RK	R-5	Rural-5 Acre	Single Family Residential
14 110397 RK	R-5	Rural-5 Acre	Single Family Residential
15 105526 RK	R-5	Rural-5 Acre	Single Family Residential
15 115010 RK	R-7,200	Residential 7,200 sq. ft.	Duplex
15 114857 RK	R-7,200	Residential 7,200 sq. ft.	Single Family Residential
15 101590 RK			Duplex
15 113453 RK	R-7,200	Residential 7,200 sq. ft.	Single Family Residential
15 114003 RK	R-5	Rural-5 Acre	SFR-Basic
15 103922 000 01 RK	R-5	Rural-5 Acre	Single Family Residential

Accessory Dwelling Units

Index # - File Name: 1.0022 - Single Family Dwellings Data\_Snohomish County.pdf

15 109826 RK	R-5	Rural-5 Acre	Single Family Residential
15 104291 RK	R-5	Rural-5 Acre	Single Family Residential
14 111807 RK	R-5	Rural-5 Acre	Single Family Residential
14 112419 RK	F	Forestry	SFR-Basic
15 116449 RK	R-5	Rural-5 Acre	Single Family Residential
14 114571 000 01 RK	R-5	Rural-5 Acre	Single Family Residential
15 106721 RK	R-5	Rural-5 Acre	Single Family Residential
15 112335 RK	R-5	Rural-5 Acre	Single Family Residential
15 106083 RK	R-5	Rural-5 Acre	SFR-Basic
14 111437 RK	R-5	Rural-5 Acre	Single Family Residential
15 107743 RK	R-5	Rural-5 Acre	Single Family Residential
15 113566 RK	R-7,200	Residential 7,200 sq. ft.	Single Family Residential
15 115624 RK	R-5	Rural-5 Acre	Single Family Residential
15 100513 RK	R-5	Rural-5 Acre	Single Family Residential
15 108942 RK	MR	Multiple Residential	Duplex
14 115201 RK	F	Forestry	Single Family Residential
15 103851 RK	R-5	Rural-5 Acre	Single Family Residential
15 115579 RK	R-5	Rural-5 Acre	Single Family Residential
15 108928 000 01 RK	R-5	Rural-5 Acre	Single Family Residential
15 117166 000 01 RK	R-5	Rural-5 Acre	Single Family Residential
15 117350 RK	R-5	Rural-5 Acre	Single Family Residential
15 115991 RK	MR	Multiple Residential	Duplex
15 101332 RK	R-9,600	Residential 9,600 sq. ft.	Single Family Residential
15 112887 RK	R-5	Rural-5 Acre	Single Family Residential
15 107218 RK	R-5	Rural-5 Acre	Single Family Residential
14 108826 RK	R-12,500	Residential 12,500 sq. ft.	Single Family Residential
15 102532 RK	PRD-20,000(M	Residential 20,000 sq. ft.	Single Family Residential
15 110865 RK	R-9,600	Residential 9,600 sq. ft.	Single Family Residential
15 103473 RK	F	Forestry	SFR-Basic
14 111785 000 01 RK	R-5	Rural-5 Acre	Single Family Residential
15 102230 RK	R-8,400	Residential 8,400 sq. ft.	Duplex-Basic
14 111304 RK	R-5	Rural-5 Acre	SFR-Basic
15 105564 RK	R-5	Rural-5 Acre	SFR-Basic
14 115360 RK	R-8,400	Residential 8,400 sq. ft.	Single Family Residential
14 115629 RK	R-5	Rural-5 Acre	Single Family Residential
15 104060 RK	R-9,600	Residential 9,600 sq. ft.	Duplex
14 114550 RK	R-5	Rural-5 Acre	Accessory Apt Detached
15 116145 RK	R-5	Rural-5 Acre	Single Family Residential
15 101524 RK	R-5	Rural-5 Acre	Single Family Residential
15 110669 RK	LDMR	Low Density Multiple Reside	Single Family Residential
15 103892 RK	LDMR : R-8,40	Low Density Multiple Reside	Duplex-Basic
15 103151 000 01 RK	R-8,400	Residential 8,400 sq. ft.	Single Family Residential
14 115800 RK	R-5	Rural-5 Acre	Single Family Residential
15 102179 RK	R-5	Rural-5 Acre	Single Family Residential
15 108467 RK	R-9,600	Residential 9,600 sq. ft.	SFR-Basic
15 109844 RK	R-9,600	Residential 9,600 sq. ft.	SFR-Basic
15 117569 RK	R-5	Rural-5 Acre	Single Family Residential

Accessory Dwelling Units

Index # - File Name: 1.0022 - Single Family Dwellings Data\_Snohomish County.pdf

14 113760 RK	F	Forestry	SFR-Basic
15 109301 RK	R-5	Rural-5 Acre	SFR-Basic
15 101489 MH	A-10	Agriculture-10 Acre	Single Wide
15 107031 RK	R-5	Rural-5 Acre	Single Family Residential
15 101646 RK	R-5	Rural-5 Acre	SFR-Basic
14 116245 RK	R-5	Rural-5 Acre	Single Family Residential
15 108508 RK	R-5	Rural-5 Acre	Single Family Residential
15 101390 RK	R-5	Rural-5 Acre	Single Family Residential
15 115476 RK	F	Forestry	Single Family Residential
14 116248 RK	F : R-5	Forestry : Rural-5 Acre	SFR-Basic
15 112477 000 01 RK	R-5	Rural-5 Acre	Single Family Residential
13 110414 RK	R-5	Rural-5 Acre	Single Family Residential
15 112950 RK	PRD SA-1	Suburban Agriculture-1 Acre	Single Family Residential
15 109552 RK	F	Forestry	Single Family Residential
15 103678 RK	R-5	Rural-5 Acre	Single Family Residential
15 111504 RK	R-5	Rural-5 Acre	Single Family Residential
15 110859 RK	R-5	Rural-5 Acre	Single Family Residential
15 114720 RK	R-5	Rural-5 Acre	Single Family Residential
15 107553 MH	MHP	Mobile Home Park	MH Park-Double Wide
14 109469 RK	R-5	Rural-5 Acre	Single Family Residential
15 113727 RK	R-5	Rural-5 Acre	Single Family Residential
14 111501 RK	R-5	Rural-5 Acre	Single Family Residential
14 115171 RK	R-5	Rural-5 Acre	SFR-Basic
14 114413 RK	F	Forestry	Single Family Residential
14 113041 RK	R-5	Rural-5 Acre	Single Family Residential
15 111278 RK	R-5	Rural-5 Acre	Single Family Residential
14 116461 RK	R-5	Rural-5 Acre	Single Family Residential
15 100980 RK	R-5	Rural-5 Acre	Single Family Residential
14 115184 RK	R-5	Rural-5 Acre	Single Family Residential
14 115173 RK	R-5	Rural-5 Acre	Single Family Residential
15 106742 RK	R-5	Rural-5 Acre	Single Family Residential
15 107158 RK	R-5	Rural-5 Acre	SFR-Basic
15 107155 RK	R-5	Rural-5 Acre	SFR-Basic
15 107156 RK	R-5	Rural-5 Acre	SFR-Basic
15 107157 RK	R-5	Rural-5 Acre	SFR-Basic
15 102370 RK	R-5	Rural-5 Acre	SFR-Basic
15 103199 RK	R-5	Rural-5 Acre	SFR-Basic
15 102371 RK	R-5	Rural-5 Acre	SFR-Basic
15 106811 000 01 RK	R-5	Rural-5 Acre	Single Family Residential
15 106396 RK	R-7,200	Residential 7,200 sq. ft.	Single Family Residential
15 113231 000 01 RK	R-5	Rural-5 Acre	Single Family Residential
15 102470 RK	R-5	Rural-5 Acre	Single Family Residential
14 114526 RK	R-5	Rural-5 Acre	Single Family Residential
15 104299 RK	R-5	Rural-5 Acre	Single Family Residential
15 104331 RK	R-5	Rural-5 Acre	SFR-Basic
15 110132 RK	A-10	Agriculture-10 Acre	Single Family Residential
15 111160 RK	R-5	Rural-5 Acre	Single Family Residential



Accessory Dwelling Units

Index # - File Name: 1.0022 - Single Family Dwellings Data\_Snohomish County.pdf

15 106176 RK	R-5	Rural-5 Acre	Single Family Residential
14 104031 RK	R-5	Rural-5 Acre	Single Family Residential
15 102582 RK	R-5	Rural-5 Acre	SFR-Basic
15 103383 RK			Duplex-Basic
15 107305 RK	R-9,600	Residential 9,600 sq. ft.	Single Family Residential
15 100410 MH	R-5	Rural-5 Acre	Double Wide
14 116408 RK	R-5	Rural-5 Acre	Single Family Residential
15 102688 000 01 RK	R-9,600	Residential 9,600 sq. ft.	Accessory Apt Attached
15 110296 RK	R-5	Rural-5 Acre	Single Family Residential
15 107717 RK	R-5	Rural-5 Acre	SFR-Basic
15 113654 RK	R-5	Rural-5 Acre	Single Family Residential
15 115839 RK	R-5	Rural-5 Acre	Single Family Residential
15 102080 RK	R-5	Rural-5 Acre	Single Family Residential
15 102081 RK	R-5	Rural-5 Acre	Single Family Residential
15 116397 RK	R-5	Rural-5 Acre	Single Family Residential
15 110212 RK	R-5	Rural-5 Acre	Single Family Residential
15 111676 RK	R-5	Rural-5 Acre	Single Family Residential
14 111369 RK	R-5	Rural-5 Acre	Single Family Residential
15 107173 RK	R-5	Rural-5 Acre	Single Family Residential
15 102863 RK	R-7,200	Residential 7,200 sq. ft.	Single Family Residential
15 113403 RK	R-7,200	Residential 7,200 sq. ft.	Single Family Residential
15 116118 RK	R-5	Rural-5 Acre	Single Family Residential
15 110602 RK	R-5	Rural-5 Acre	Single Family Residential
15 110639 RK	R-5	Rural-5 Acre	SFR-Basic
15 110640 RK	R-5	Rural-5 Acre	SFR-Basic
15 110641 RK	R-5	Rural-5 Acre	SFR-Basic
15 110642 RK	R-5	Rural-5 Acre	SFR-Basic
15 110643 RK	R-5	Rural-5 Acre	SFR-Basic
15 110644 RK	R-5	Rural-5 Acre	SFR-Basic
15 110645 RK	R-5	Rural-5 Acre	SFR-Basic
14 112904 RK	R-5	Rural-5 Acre	Single Family Residential
15 102606 RK	R-5	Rural-5 Acre	Single Family Residential
14 116240 RK	R-5	Rural-5 Acre	SFR-Basic
14 114304 RK	R-7,200	Residential 7,200 sq. ft.	SFR-Basic
14 114305 RK	R-7,200	Residential 7,200 sq. ft.	SFR-Basic
15 103461 RK	R-5	Rural-5 Acre	Single Family Residential
15 115312 RK	R-7,200	Residential 7,200 sq. ft.	Single Family Residential
15 103853 RK	R-9,600	Residential 9,600 sq. ft.	Single Family Residential
14 107598 RK	R-5	Rural-5 Acre	SFR-Basic
15 118381 RK	R-5	Rural-5 Acre	SFR-Basic
15 111648 RK	R-5	Rural-5 Acre	SFR-Basic
15 111651 RK	R-5	Rural-5 Acre	SFR-Basic
15 112377 RK	R-5	Rural-5 Acre	SFR-Basic
15 112635 RK	R-5	Rural-5 Acre	SFR-Basic
15 112376 RK	R-5	Rural-5 Acre	SFR-Basic
15 114283 RK	R-5	Rural-5 Acre	SFR-Basic
14 113091 RK	R-5	Rural-5 Acre	SFR-Basic

Accessory Dwelling Units

Index # - File Name: 1.0022 - Single Family Dwellings Data\_Snohomish County.pdf

14 113090 RK	R-5	Rural-5 Acre	SFR-Basic
15 108438 RK	R-5	Rural-5 Acre	SFR-Basic
15 107308 RK	R-5	Rural-5 Acre	SFR-Basic
15 112848 RK	R-5	Rural-5 Acre	SFR-Basic
15 112315 RK	R-5	Rural-5 Acre	SFR-Basic
14 107710 RK	R-5	Rural-5 Acre	SFR-Basic
14 113092 RK	R-5	Rural-5 Acre	SFR-Basic
15 110869 RK	R-5	Rural-5 Acre	Single Family Residential
15 107304 RK	R-5	Rural-5 Acre	Single Family Residential
15 101156 RK	R-5	Rural-5 Acre	SFR-Basic
15 109879 RK	R-5	Rural-5 Acre	SFR-Basic
15 114801 RK	R-5	Rural-5 Acre	SFR-Basic
15 112316 RK	R-5	Rural-5 Acre	SFR-Basic
15 112851 RK	R-5	Rural-5 Acre	SFR-Basic
15 107756 RK	R-5	Rural-5 Acre	SFR-Basic
15 108550 RK	R-5	Rural-5 Acre	SFR-Basic
15 109881 RK	R-5	Rural-5 Acre	SFR-Basic
15 109885 RK	R-5	Rural-5 Acre	SFR-Basic
15 110756 RK	R-5	Rural-5 Acre	SFR-Basic
15 105585 RK	MR	Multiple Residential	Single Family Residential
15 115344 RK	R-5	Rural-5 Acre	Single Family Residential
15 102617 RK	R-5	Rural-5 Acre	Single Family Residential
15 117442 RK	MR : R-8,400	Multiple Residential : Reside	SFR-Basic
15 117443 RK	MR : R-8,400	Multiple Residential : Reside	SFR-Basic
15 116121 RK	MR : R-8,400	Multiple Residential : Reside	SFR-Basic
15 116122 RK	MR : R-8,400	Multiple Residential : Reside	SFR-Basic
15 116124 RK	MR : R-8,400	Multiple Residential : Reside	SFR-Basic
15 116127 RK	MR : R-8,400	Multiple Residential : Reside	SFR-Basic
15 117434 RK	MR : R-8,400	Multiple Residential : Reside	SFR-Basic
15 117435 RK	MR : R-8,400	Multiple Residential : Reside	SFR-Basic
15 105442 RK	R-5	Rural-5 Acre	Single Family Residential
15 102001 RK	R-5	Rural-5 Acre	Single Family Residential
15 102377 RK	F : R-5	Forestry : Rural-5 Acre	SFR-Basic
14 116246 RK	F : R-5	Forestry : Rural-5 Acre	SFR-Basic
14 110262 RK	R-7,200(PRD)	Residential 7,200 sq. ft.	SFR-Basic
15 108856 RK	R-9,600	Residential 9,600 sq. ft.	Single Family Residential
14 115333 RK	R-7,200	Residential 7,200 sq. ft.	SFR-Basic
14 115334 RK	R-7,200	Residential 7,200 sq. ft.	SFR-Basic
15 101183 RK	R-7,200	Residential 7,200 sq. ft.	SFR-Basic
15 102455 RK	R-7,200	Residential 7,200 sq. ft.	SFR-Basic
15 106875 RK	R-7,200	Residential 7,200 sq. ft.	SFR-Basic
15 106429 RK	R-7,200	Residential 7,200 sq. ft.	SFR-Basic
15 115939 RK	R-9,600	Residential 9,600 sq. ft.	SFR-Basic
15 115940 RK	R-9,600	Residential 9,600 sq. ft.	SFR-Basic
14 116173 RK	R-7,200	Residential 7,200 sq. ft.	SFR-Basic
15 109179 RK	R-7,200	Residential 7,200 sq. ft.	SFR-Basic
15 117867 RK	R-7,200	Residential 7,200 sq. ft.	SFR-Basic

Accessory Dwelling Units

Index # - File Name: 1.0022 - Single Family Dwellings Data\_Snohomish County.pdf

15 110579 RK	R-7,200(PRD)	Residential 7,200 sq. ft.	SFR-Basic
15 112402 RK	R-7,200(PRD)	Residential 7,200 sq. ft.	SFR-Basic
15 112403 RK	R-7,200(PRD)	Residential 7,200 sq. ft.	SFR-Basic
15 113290 RK	R-7,200(PRD)	Residential 7,200 sq. ft.	SFR-Basic
15 114474 RK	R-7,200(PRD)	Residential 7,200 sq. ft.	SFR-Basic
15 114475 RK	R-7,200(PRD)	Residential 7,200 sq. ft.	SFR-Basic
15 114476 RK	R-7,200(PRD)	Residential 7,200 sq. ft.	SFR-Basic
15 117665 RK	R-7,200(PRD)	Residential 7,200 sq. ft.	SFR-Basic
15 117666 RK	R-7,200(PRD)	Residential 7,200 sq. ft.	SFR-Basic
15 114480 RK	R-7,200(PRD)	Residential 7,200 sq. ft.	SFR-Basic
15 114477 RK	R-7,200(PRD)	Residential 7,200 sq. ft.	SFR-Basic
15 114478 RK	R-7,200(PRD)	Residential 7,200 sq. ft.	SFR-Basic
15 114479 RK	R-7,200(PRD)	Residential 7,200 sq. ft.	SFR-Basic
15 112404 RK	R-7,200(PRD)	Residential 7,200 sq. ft.	SFR-Basic
15 109168 RK	R-7,200(PRD)	Residential 7,200 sq. ft.	SFR-Basic
15 100394 RK	R-5	Rural-5 Acre	Single Family Residential
15 107324 RK	R-7,200	Residential 7,200 sq. ft.	SFR-Basic
15 102454 RK	R-7,200	Residential 7,200 sq. ft.	SFR-Basic
15 109178 RK	R-7,200	Residential 7,200 sq. ft.	SFR-Basic
15 103808 RK	R-7,200	Residential 7,200 sq. ft.	SFR-Basic
15 102919 RK	R-7,200	Residential 7,200 sq. ft.	SFR-Basic
14 115329 RK	R-7,200	Residential 7,200 sq. ft.	SFR-Basic
14 115330 RK	R-7,200	Residential 7,200 sq. ft.	SFR-Basic
15 104422 RK	R-7,200	Residential 7,200 sq. ft.	SFR-Basic
15 117681 RK	R-7,200	Residential 7,200 sq. ft.	SFR-Basic
15 110850 RK	R-7,200	Residential 7,200 sq. ft.	SFR-Basic
15 113068 RK	R-7,200	Residential 7,200 sq. ft.	SFR-Basic
15 115258 RK	R-7,200	Residential 7,200 sq. ft.	SFR-Basic
15 111166 RK	R-7,200	Residential 7,200 sq. ft.	SFR-Basic
15 117682 RK	R-7,200	Residential 7,200 sq. ft.	SFR-Basic
15 117683 RK	R-7,200	Residential 7,200 sq. ft.	SFR-Basic
15 117120 RK	R-7,200	Residential 7,200 sq. ft.	SFR-Basic
15 100937 RK	R-7,200	Residential 7,200 sq. ft.	SFR-Basic
15 106430 RK	R-7,200	Residential 7,200 sq. ft.	SFR-Basic
15 107202 RK	R-7,200	Residential 7,200 sq. ft.	SFR-Basic
15 106431 RK	R-7,200	Residential 7,200 sq. ft.	SFR-Basic
15 102920 RK	R-7,200	Residential 7,200 sq. ft.	SFR-Basic
15 103082 RK	R-7,200	Residential 7,200 sq. ft.	SFR-Basic
15 102456 RK	R-7,200	Residential 7,200 sq. ft.	SFR-Basic
15 104253 RK	R-7,200	Residential 7,200 sq. ft.	SFR-Basic
14 115335 RK	R-7,200	Residential 7,200 sq. ft.	SFR-Basic
14 115336 RK	R-7,200	Residential 7,200 sq. ft.	SFR-Basic
14 116174 RK	R-7,200	Residential 7,200 sq. ft.	SFR-Basic
15 101197 000 01 RK	R-5	Rural-5 Acre	Single Family Residential
15 104103 RK	R-7,200	Residential 7,200 sq. ft.	SFR-Basic
15 104104 RK	R-7,200	Residential 7,200 sq. ft.	SFR-Basic
15 104035 RK	R-7,200	Residential 7,200 sq. ft.	SFR-Basic

Accessory Dwelling Units

Index # - File Name: 1.0022 - Single Family Dwellings Data\_Snohomish County.pdf

15 104033 RK	R-7,200	Residential 7,200 sq. ft.	SFR-Basic
15 104034 RK	R-7,200	Residential 7,200 sq. ft.	SFR-Basic
15 105343 RK	R-7,200	Residential 7,200 sq. ft.	SFR-Basic
15 105344 RK	R-7,200	Residential 7,200 sq. ft.	SFR-Basic
15 104105 RK	R-7,200	Residential 7,200 sq. ft.	SFR-Basic
15 104106 RK	R-7,200	Residential 7,200 sq. ft.	SFR-Basic
15 104107 RK	R-7,200	Residential 7,200 sq. ft.	SFR-Basic
14 116399 RK	CITY	City	SFR-Basic
15 100837 RK	CITY	City	SFR-Basic
15 100838 RK	CITY	City	SFR-Basic
15 100839 RK	CITY	City	SFR-Basic
15 100840 RK	CITY	City	SFR-Basic
14 116400 RK	CITY	City	SFR-Basic
15 100841 RK	CITY	City	SFR-Basic
14 116401 RK	CITY	City	SFR-Basic
14 116402 RK	CITY	City	SFR-Basic
14 116403 RK	CITY	City	SFR-Basic
14 116404 RK	CITY	City	SFR-Basic
14 116405 RK	CITY	City	SFR-Basic
14 116406 RK	CITY	City	SFR-Basic
15 107319 RK	CITY	City	SFR-Basic
15 106121 RK	CITY	City	SFR-Basic
15 105470 RK	CITY	City	SFR-Basic
15 105471 RK	CITY	City	SFR-Basic
15 105472 RK	CITY	City	SFR-Basic
15 105473 RK	CITY	City	SFR-Basic
15 105474 RK	CITY	City	SFR-Basic
15 105475 RK	CITY	City	SFR-Basic
15 107320 RK	CITY	City	SFR-Basic
14 116407 RK	CITY	City	SFR-Basic
15 100842 RK	CITY	City	SFR-Basic
15 109164 RK	R-7,200(PRD)	Residential 7,200 sq. ft.	SFR-Basic
15 109165 RK	R-7,200(PRD)	Residential 7,200 sq. ft.	SFR-Basic
15 110580 RK	R-7,200(PRD)	Residential 7,200 sq. ft.	SFR-Basic
15 109167 RK	R-7,200(PRD)	Residential 7,200 sq. ft.	SFR-Basic
15 117664 RK	R-7,200(PRD)	Residential 7,200 sq. ft.	SFR-Basic
15 113069 RK	R-7,200	Residential 7,200 sq. ft.	SFR-Basic
15 112426 RK	R-7,200	Residential 7,200 sq. ft.	SFR-Basic
15 112338 RK	R-7,200	Residential 7,200 sq. ft.	SFR-Basic
15 111580 RK	R-7,200	Residential 7,200 sq. ft.	SFR-Basic
15 111547 RK	R-7,200	Residential 7,200 sq. ft.	SFR-Basic
15 117684 RK	R-7,200	Residential 7,200 sq. ft.	SFR-Basic
15 110852 RK	R-7,200	Residential 7,200 sq. ft.	SFR-Basic
15 116020 RK	R-7,200	Residential 7,200 sq. ft.	SFR-Basic
15 118433 RK	R-5	Rural-5 Acre	SFR-Basic
15 115246 RK	R-5	Rural-5 Acre	SFR-Basic
15 112830 RK	R-5	Rural-5 Acre	SFR-Basic

Accessory Dwelling Units

Index # - File Name: 1.0022 - Single Family Dwellings Data\_Snohomish County.pdf

15 115819 RK	R-5	Rural-5 Acre	Single Family Residential
15 102052 RK	R-5	Rural-5 Acre	Single Family Residential
15 101152 RK	R-5	Rural-5 Acre	Single Family Residential
15 101337 RK	R-5	Rural-5 Acre	Single Family Residential
15 101484 RK	R-5	Rural-5 Acre	Single Family Residential
15 113629 RK	R-8,400	Residential 8,400 sq. ft.	Single Family Residential
15 109087 RK	R-5	Rural-5 Acre	Single Family Residential
15 102221 RK	R-8,400	Residential 8,400 sq. ft.	SFR-Basic
15 102742 RK	R-9,600	Residential 9,600 sq. ft.	Single Family Residential
15 109073 RK	R-5	Rural-5 Acre	SFR-Basic
15 109074 RK	R-5	Rural-5 Acre	SFR-Basic
15 109070 RK	R-5	Rural-5 Acre	SFR-Basic
14 116241 RK	R-5	Rural-5 Acre	SFR-Basic
15 100108 RK	R-5	Rural-5 Acre	Single Family Residential
15 108792 RK	R-5	Rural-5 Acre	SFR-Basic
15 114347 RK	R-5	Rural-5 Acre	SFR-Basic
15 106951 RK	R-5	Rural-5 Acre	SFR-Basic
15 104526 RK	R-5	Rural-5 Acre	Single Family Residential
15 117831 RK	R-7,200(PRD)	Residential 7,200 sq. ft.	SFR-Basic
15 117832 RK	R-7,200(PRD)	Residential 7,200 sq. ft.	SFR-Basic
15 117833 RK	R-7,200(PRD)	Residential 7,200 sq. ft.	SFR-Basic
15 115080 RK	R-7,200(PRD)	Residential 7,200 sq. ft.	SFR-Basic
15 115081 RK	R-7,200(PRD)	Residential 7,200 sq. ft.	SFR-Basic
15 115082 RK	R-7,200(PRD)	Residential 7,200 sq. ft.	SFR-Basic
15 114052 RK	R-7,200(PRD)	Residential 7,200 sq. ft.	SFR-Basic
15 115083 RK	R-7,200(PRD)	Residential 7,200 sq. ft.	SFR-Basic
15 103202 RK	R-5	Rural-5 Acre	Single Family Residential
15 103652 RK	R-7,200	Residential 7,200 sq. ft.	SFR-Basic
15 110565 RK	R-7,200	Residential 7,200 sq. ft.	SFR-Basic
15 110566 RK	R-7,200	Residential 7,200 sq. ft.	SFR-Basic
15 110567 RK	R-7,200	Residential 7,200 sq. ft.	SFR-Basic
15 110568 RK	R-7,200	Residential 7,200 sq. ft.	SFR-Basic
15 110569 RK	R-7,200	Residential 7,200 sq. ft.	SFR-Basic
15 110570 RK	R-7,200	Residential 7,200 sq. ft.	SFR-Basic
15 110571 RK	R-7,200	Residential 7,200 sq. ft.	SFR-Basic
15 110572 RK	R-7,200	Residential 7,200 sq. ft.	SFR-Basic
15 110573 RK	R-7,200	Residential 7,200 sq. ft.	SFR-Basic
15 110574 RK	R-7,200	Residential 7,200 sq. ft.	SFR-Basic
15 113292 RK	R-7,200	Residential 7,200 sq. ft.	SFR-Basic
15 117658 RK	R-7,200	Residential 7,200 sq. ft.	SFR-Basic
15 115746 RK	R-7,200	Residential 7,200 sq. ft.	SFR-Basic
15 114437 RK	R-7,200	Residential 7,200 sq. ft.	SFR-Basic
15 114438 RK	R-7,200	Residential 7,200 sq. ft.	SFR-Basic
15 113293 RK	R-7,200	Residential 7,200 sq. ft.	SFR-Basic
15 110575 RK	R-7,200	Residential 7,200 sq. ft.	SFR-Basic
15 110576 RK	R-7,200	Residential 7,200 sq. ft.	SFR-Basic
15 110577 RK	R-7,200	Residential 7,200 sq. ft.	SFR-Basic

Accessory Dwelling Units

Index # - File Name: 1.0022 - Single Family Dwellings Data\_Snohomish County.pdf

15 114774 RK	RRT-10	Rural Resource Transition-1(Single Family Residential	
15 106642 RK	R-7,200(PRD)	Residential 7,200 sq. ft.	SFR-Basic
15 107285 RK	R-7,200(PRD)	Residential 7,200 sq. ft.	SFR-Basic
15 106643 RK	R-7,200(PRD)	Residential 7,200 sq. ft.	SFR-Basic
15 107164 RK	R-7,200(PRD)	Residential 7,200 sq. ft.	SFR-Basic
15 106644 RK	R-7,200(PRD)	Residential 7,200 sq. ft.	SFR-Basic
15 106645 RK	R-7,200(PRD)	Residential 7,200 sq. ft.	SFR-Basic
15 107165 RK	R-7,200(PRD)	Residential 7,200 sq. ft.	SFR-Basic
15 107166 RK	R-7,200(PRD)	Residential 7,200 sq. ft.	SFR-Basic
15 106646 RK	R-7,200(PRD)	Residential 7,200 sq. ft.	SFR-Basic
15 114399 RK	R-7,200(PRD)	Residential 7,200 sq. ft.	SFR-Basic
15 111555 RK	R-7,200(PRD)	Residential 7,200 sq. ft.	SFR-Basic
15 112318 RK	R-7,200(PRD)	Residential 7,200 sq. ft.	SFR-Basic
15 107167 RK	R-7,200(PRD)	Residential 7,200 sq. ft.	SFR-Basic
15 107286 RK	R-7,200(PRD)	Residential 7,200 sq. ft.	SFR-Basic
15 107168 RK	R-7,200(PRD)	Residential 7,200 sq. ft.	SFR-Basic
15 111556 RK	R-7,200(PRD)	Residential 7,200 sq. ft.	SFR-Basic
15 113373 RK	R-9,600	Residential 9,600 sq. ft.	SFR-Basic
15 113374 RK	R-9,600	Residential 9,600 sq. ft.	SFR-Basic
15 115918 RK	R-9,600	Residential 9,600 sq. ft.	SFR-Basic
15 115919 RK	R-9,600	Residential 9,600 sq. ft.	SFR-Basic
15 118278 RK	R-9,600	Residential 9,600 sq. ft.	SFR-Basic
15 110130 RK	R-7,200	Residential 7,200 sq. ft.	SFR-Basic
15 110124 RK	R-7,200	Residential 7,200 sq. ft.	SFR-Basic
15 110129 RK	R-7,200	Residential 7,200 sq. ft.	SFR-Basic
15 110125 RK	R-7,200	Residential 7,200 sq. ft.	SFR-Basic
15 110128 RK	R-7,200	Residential 7,200 sq. ft.	SFR-Basic
15 101176 RK	R-5	Rural-5 Acre	Single Family Residential
15 103343 RK	R-7,200	Residential 7,200 sq. ft.	SFR-Basic
15 103344 RK	R-7,200	Residential 7,200 sq. ft.	SFR-Basic
15 103345 RK	R-7,200	Residential 7,200 sq. ft.	SFR-Basic
15 109490 RK	R-9,600	Residential 9,600 sq. ft.	SFR-Basic
15 118287 RK	R-9,600	Residential 9,600 sq. ft.	SFR-Basic
15 118288 RK	R-9,600	Residential 9,600 sq. ft.	SFR-Basic
15 113958 RK	R-9,600	Residential 9,600 sq. ft.	SFR-Basic
15 113959 RK	R-9,600	Residential 9,600 sq. ft.	SFR-Basic
15 113960 RK	R-9,600	Residential 9,600 sq. ft.	SFR-Basic
15 113961 RK	R-9,600	Residential 9,600 sq. ft.	SFR-Basic
15 113962 RK	R-9,600	Residential 9,600 sq. ft.	SFR-Basic
15 109488 RK	R-9,600	Residential 9,600 sq. ft.	SFR-Basic
15 109489 RK	R-9,600	Residential 9,600 sq. ft.	SFR-Basic
15 108679 RK	R-9,600	Residential 9,600 sq. ft.	SFR-Basic
15 108680 RK	R-9,600	Residential 9,600 sq. ft.	SFR-Basic
15 105324 RK	R-9,600	Residential 9,600 sq. ft.	SFR-Basic
15 105325 RK	R-9,600	Residential 9,600 sq. ft.	SFR-Basic
15 105326 RK	R-9,600	Residential 9,600 sq. ft.	SFR-Basic
15 103485 RK	R-9,600	Residential 9,600 sq. ft.	SFR-Basic

Accessory Dwelling Units

Index # - File Name: 1.0022 - Single Family Dwellings Data\_Snohomish County.pdf

15 111557 RK	R-7,200	Residential 7,200 sq. ft.	SFR-Basic
15 104543 RK	R-7,200	Residential 7,200 sq. ft.	SFR-Basic
15 105761 RK	R-7,200	Residential 7,200 sq. ft.	SFR-Basic
15 111558 RK	R-7,200	Residential 7,200 sq. ft.	SFR-Basic
15 107395 RK	R-7,200	Residential 7,200 sq. ft.	SFR-Basic
15 105762 RK	R-7,200	Residential 7,200 sq. ft.	SFR-Basic
15 105763 RK	R-7,200	Residential 7,200 sq. ft.	SFR-Basic
15 111559 RK	R-7,200	Residential 7,200 sq. ft.	SFR-Basic
15 114400 RK	R-7,200	Residential 7,200 sq. ft.	SFR-Basic
15 118191 RK	R-7,200	Residential 7,200 sq. ft.	SFR-Basic
15 107396 RK	R-7,200	Residential 7,200 sq. ft.	SFR-Basic
15 107397 RK	R-7,200	Residential 7,200 sq. ft.	SFR-Basic
15 107398 RK	R-7,200	Residential 7,200 sq. ft.	SFR-Basic
15 118192 RK	R-7,200	Residential 7,200 sq. ft.	SFR-Basic
15 107399 RK	R-7,200	Residential 7,200 sq. ft.	SFR-Basic
15 118193 RK	R-7,200	Residential 7,200 sq. ft.	SFR-Basic
15 118679 RK	R-7,200	Residential 7,200 sq. ft.	SFR-Basic
15 107497 RK	R-7,200	Residential 7,200 sq. ft.	SFR-Basic
15 107498 RK	R-7,200	Residential 7,200 sq. ft.	SFR-Basic
15 107499 RK	R-7,200	Residential 7,200 sq. ft.	SFR-Basic
15 106534 RK	R-7,200	Residential 7,200 sq. ft.	SFR-Basic
15 106117 RK	R-7,200	Residential 7,200 sq. ft.	SFR-Basic
15 106118 RK	R-7,200	Residential 7,200 sq. ft.	SFR-Basic
15 103346 RK	R-7,200	Residential 7,200 sq. ft.	SFR-Basic
15 103347 RK	R-7,200	Residential 7,200 sq. ft.	SFR-Basic
14 114007 RK	R-5	Rural-5 Acre	SFR-Basic
15 110552 RK	R-7,200(PRD)	Residential 7,200 sq. ft.	SFR-Basic
15 110058 RK	R-7,200(PRD)	Residential 7,200 sq. ft.	SFR-Basic
15 109172 RK	R-7,200(PRD)	Residential 7,200 sq. ft.	SFR-Basic
15 110553 RK	R-7,200(PRD)	Residential 7,200 sq. ft.	SFR-Basic
15 109432 RK	R-7,200(PRD)	Residential 7,200 sq. ft.	SFR-Basic
15 109173 RK	R-7,200(PRD)	Residential 7,200 sq. ft.	SFR-Basic
15 109174 RK	R-7,200(PRD)	Residential 7,200 sq. ft.	SFR-Basic
15 110554 RK	R-7,200(PRD)	Residential 7,200 sq. ft.	SFR-Basic
15 110555 RK	R-7,200(PRD)	Residential 7,200 sq. ft.	SFR-Basic
15 110556 RK	R-7,200(PRD)	Residential 7,200 sq. ft.	SFR-Basic
15 110557 RK	R-7,200(PRD)	Residential 7,200 sq. ft.	SFR-Basic
15 110558 RK	R-7,200(PRD)	Residential 7,200 sq. ft.	SFR-Basic
15 110059 RK	R-7,200(PRD)	Residential 7,200 sq. ft.	SFR-Basic
15 110559 RK	R-7,200(PRD)	Residential 7,200 sq. ft.	SFR-Basic
15 110560 RK	R-7,200(PRD)	Residential 7,200 sq. ft.	SFR-Basic
15 110561 RK	R-7,200(PRD)	Residential 7,200 sq. ft.	SFR-Basic
15 110562 RK	R-7,200(PRD)	Residential 7,200 sq. ft.	SFR-Basic
15 110563 RK	R-7,200(PRD)	Residential 7,200 sq. ft.	SFR-Basic
15 110564 RK	R-7,200(PRD)	Residential 7,200 sq. ft.	SFR-Basic
15 109433 RK	R-7,200(PRD)	Residential 7,200 sq. ft.	SFR-Basic
15 109434 RK	R-7,200(PRD)	Residential 7,200 sq. ft.	SFR-Basic

Accessory Dwelling Units

Index # - File Name: 1.0022 - Single Family Dwellings Data\_Snohomish County.pdf

14 113657 RK	R-7,200	Residential 7,200 sq. ft.	Single Family Residential
15 102934 RK	R-7,200	Residential 7,200 sq. ft.	Single Family Residential
15 104189 RK	R-7,200	Residential 7,200 sq. ft.	Single Family Residential
15 102932 RK	R-7,200	Residential 7,200 sq. ft.	Single Family Residential
15 102930 RK	R-7,200	Residential 7,200 sq. ft.	Single Family Residential
15 102472 RK	R-7,200	Residential 7,200 sq. ft.	Single Family Residential
15 103565 RK	R-7,200	Residential 7,200 sq. ft.	Single Family Residential
15 109199 RK	R-7,200	Residential 7,200 sq. ft.	Single Family Residential
15 102466 RK	R-7,200	Residential 7,200 sq. ft.	Single Family Residential
15 111304 RK	R-7,200	Residential 7,200 sq. ft.	Single Family Residential
15 102471 RK	R-7,200	Residential 7,200 sq. ft.	Single Family Residential
15 106990 RK	R-7,200	Residential 7,200 sq. ft.	Single Family Residential
14 114200 RK	R-5	Rural-5 Acre	SFR-Basic
14 114202 RK	R-5	Rural-5 Acre	SFR-Basic
15 103482 RK	R-9,600	Residential 9,600 sq. ft.	SFR-Basic
15 104250 RK	R-9,600	Residential 9,600 sq. ft.	SFR-Basic
15 104251 RK	R-9,600	Residential 9,600 sq. ft.	SFR-Basic
15 115360 RK	R-9,600	Residential 9,600 sq. ft.	SFR-Basic
15 102433 RK	R-7,200	Residential 7,200 sq. ft.	Single Family Residential
15 117215 RK	R-5	Rural-5 Acre	SFR-Basic
15 117213 RK	R-5	Rural-5 Acre	SFR-Basic
15 117234 RK	R-7,200	Residential 7,200 sq. ft.	SFR-Basic
15 117235 RK	R-7,200	Residential 7,200 sq. ft.	SFR-Basic
15 117236 RK	R-7,200	Residential 7,200 sq. ft.	SFR-Basic
15 115043 RK	R-7,200	Residential 7,200 sq. ft.	SFR-Basic
15 115044 RK	R-7,200	Residential 7,200 sq. ft.	SFR-Basic
15 112619 RK	R-7,200	Residential 7,200 sq. ft.	SFR-Basic
15 112620 RK	R-7,200	Residential 7,200 sq. ft.	SFR-Basic
15 112621 RK	R-7,200	Residential 7,200 sq. ft.	SFR-Basic
15 110997 RK	R-7,200	Residential 7,200 sq. ft.	SFR-Basic
15 106432 RK	R-7,200	Residential 7,200 sq. ft.	SFR-Basic
15 106433 RK	R-7,200	Residential 7,200 sq. ft.	SFR-Basic
15 106434 RK	R-7,200	Residential 7,200 sq. ft.	SFR-Basic
15 104578 RK	R-7,200	Residential 7,200 sq. ft.	SFR-Basic
15 104579 RK	R-7,200	Residential 7,200 sq. ft.	SFR-Basic
15 104580 RK	R-7,200	Residential 7,200 sq. ft.	SFR-Basic
15 104581 RK	R-7,200	Residential 7,200 sq. ft.	SFR-Basic
15 104582 RK	R-7,200	Residential 7,200 sq. ft.	SFR-Basic
15 106435 RK	R-7,200	Residential 7,200 sq. ft.	SFR-Basic
15 105283 RK	R-7,200	Residential 7,200 sq. ft.	SFR-Basic
15 104583 RK	R-7,200	Residential 7,200 sq. ft.	SFR-Basic
15 105284 RK	R-7,200	Residential 7,200 sq. ft.	SFR-Basic
15 106436 RK	R-7,200	Residential 7,200 sq. ft.	SFR-Basic
15 106437 RK	R-7,200	Residential 7,200 sq. ft.	SFR-Basic
15 109485 RK	R-7,200	Residential 7,200 sq. ft.	SFR-Basic
15 112622 RK	R-7,200	Residential 7,200 sq. ft.	SFR-Basic
15 112623 RK	R-7,200	Residential 7,200 sq. ft.	SFR-Basic



Accessory Dwelling Units

Index # - File Name: 1.0022 - Single Family Dwellings Data\_Snohomish County.pdf

15 110998 RK	R-7,200	Residential 7,200 sq. ft.	SFR-Basic
15 109486 RK	R-7,200	Residential 7,200 sq. ft.	SFR-Basic
15 109487 RK	R-7,200	Residential 7,200 sq. ft.	SFR-Basic
15 110999 RK	R-7,200	Residential 7,200 sq. ft.	SFR-Basic
15 115045 RK	R-7,200	Residential 7,200 sq. ft.	SFR-Basic
15 115046 RK	R-7,200	Residential 7,200 sq. ft.	SFR-Basic
15 112737 RK	R-7,200	Residential 7,200 sq. ft.	SFR-Basic
15 117237 RK	R-7,200	Residential 7,200 sq. ft.	SFR-Basic
15 112624 RK	R-7,200	Residential 7,200 sq. ft.	SFR-Basic
15 118795 RK	R-5	Rural-5 Acre	Single Family Residential
14 115603 RK	R-9,600	Residential 9,600 sq. ft.	Single Family Residential
15 109340 RK	R-5	Rural-5 Acre	Single Family Residential
14 114622 RK	R-5	Rural-5 Acre	Single Family Residential
14 111387 RK	R-5	Rural-5 Acre	Single Family Residential
15 102061 RK	R-5	Rural-5 Acre	Single Family Residential
15 112674 RK	R-5	Rural-5 Acre	Single Family Residential
15 106965 RK	R-9,600	Residential 9,600 sq. ft.	Single Family Residential
15 104536 RK	R-9,600	Residential 9,600 sq. ft.	Single Family Residential
15 104531 RK	R-9,600	Residential 9,600 sq. ft.	Single Family Residential
15 104534 RK	R-9,600	Residential 9,600 sq. ft.	Single Family Residential
15 106088 RK	R-9,600	Residential 9,600 sq. ft.	Single Family Residential
15 106089 RK	R-9,600	Residential 9,600 sq. ft.	Single Family Residential
15 106399 RK	R-9,600	Residential 9,600 sq. ft.	Single Family Residential
15 106825 RK	R-9,600	Residential 9,600 sq. ft.	SFR-Basic
15 104533 RK	R-9,600	Residential 9,600 sq. ft.	Single Family Residential
15 104538 RK	R-9,600	Residential 9,600 sq. ft.	Single Family Residential
15 110947 RK	R-7,200	Residential 7,200 sq. ft.	Single Family Residential
15 110946 RK	R-7,200	Residential 7,200 sq. ft.	Single Family Residential
15 102437 RK	R-7,200	Residential 7,200 sq. ft.	Single Family Residential
15 102439 RK	R-7,200	Residential 7,200 sq. ft.	Single Family Residential
15 102440 RK	R-7,200	Residential 7,200 sq. ft.	Single Family Residential
15 102436 RK	R-7,200	Residential 7,200 sq. ft.	Single Family Residential
15 102434 RK	R-7,200	Residential 7,200 sq. ft.	Single Family Residential
15 114680 RK	R-5	Rural-5 Acre	SFR-Basic
14 115948 RK	R-7,200	Residential 7,200 sq. ft.	Single Family Residential
15 104405 RK	R-9,600	Residential 9,600 sq. ft.	SFR-Basic
14 111137 RK	A-10	Agriculture-10 Acre	Single Family Residential
15 117561 RK	R-7,200	Residential 7,200 sq. ft.	SFR-Basic
15 102518 RK	R-7,200	Residential 7,200 sq. ft.	SFR-Basic
15 106026 RK	R-5	Rural-5 Acre	SFR-Basic
15 106023 RK	R-5	Rural-5 Acre	SFR-Basic
15 108672 RK	R-5	Rural-5 Acre	Single Family Residential
15 106659 RK	R-5	Rural-5 Acre	SFR-Basic
15 106660 RK	R-5	Rural-5 Acre	SFR-Basic
15 106029 RK	R-5	Rural-5 Acre	SFR-Basic
15 106656 RK	R-5	Rural-5 Acre	SFR-Basic
15 108671 RK	R-5	Rural-5 Acre	SFR-Basic

Accessory Dwelling Units

Index # - File Name: 1.0022 - Single Family Dwellings Data\_Snohomish County.pdf

15 106658 RK	R-5	Rural-5 Acre	Single Family Residential
15 109334 RK	R-5	Rural-5 Acre	Single Family Residential
15 118662 RK	R-7,200	Residential 7,200 sq. ft.	SFR-Basic
15 118663 RK	R-7,200	Residential 7,200 sq. ft.	SFR-Basic
14 110713 RK	R-5	Rural-5 Acre	Single Family Residential
14 116340 RK	R-7,200	Residential 7,200 sq. ft.	SFR-Basic
14 116341 RK	R-7,200	Residential 7,200 sq. ft.	SFR-Basic
15 101427 RK	R-7,200	Residential 7,200 sq. ft.	SFR-Basic
15 101428 RK	R-7,200	Residential 7,200 sq. ft.	SFR-Basic
15 101429 RK	R-7,200	Residential 7,200 sq. ft.	SFR-Basic
14 116342 RK	R-7,200	Residential 7,200 sq. ft.	SFR-Basic
14 116343 RK	R-7,200	Residential 7,200 sq. ft.	SFR-Basic
14 116385 RK	R-7,200	Residential 7,200 sq. ft.	SFR-Basic
14 116386 RK	R-7,200	Residential 7,200 sq. ft.	SFR-Basic
14 116344 RK	R-7,200	Residential 7,200 sq. ft.	SFR-Basic
15 101430 RK	R-7,200	Residential 7,200 sq. ft.	SFR-Basic
15 101431 RK	R-7,200	Residential 7,200 sq. ft.	SFR-Basic
15 101432 RK	R-7,200	Residential 7,200 sq. ft.	SFR-Basic
15 102756 RK	R-7,200	Residential 7,200 sq. ft.	SFR-Basic
15 102757 RK	R-7,200	Residential 7,200 sq. ft.	SFR-Basic
15 102758 RK	R-7,200	Residential 7,200 sq. ft.	SFR-Basic
15 102759 RK	R-7,200	Residential 7,200 sq. ft.	SFR-Basic
15 102760 RK	R-7,200	Residential 7,200 sq. ft.	SFR-Basic
15 102761 RK	R-7,200	Residential 7,200 sq. ft.	SFR-Basic
15 102762 RK	R-7,200	Residential 7,200 sq. ft.	SFR-Basic
15 102763 RK	R-7,200	Residential 7,200 sq. ft.	SFR-Basic
15 102764 RK	R-7,200	Residential 7,200 sq. ft.	SFR-Basic
15 112757 RK	R-7,200	Residential 7,200 sq. ft.	SFR-Basic
15 114382 RK	R-7,200	Residential 7,200 sq. ft.	SFR-Basic
15 114383 RK	R-7,200	Residential 7,200 sq. ft.	SFR-Basic
15 112759 RK	R-7,200	Residential 7,200 sq. ft.	SFR-Basic
15 112761 RK	R-7,200	Residential 7,200 sq. ft.	SFR-Basic
15 112762 RK	R-7,200	Residential 7,200 sq. ft.	SFR-Basic
15 116152 RK	R-7,200	Residential 7,200 sq. ft.	SFR-Basic
15 114765 RK	R-7,200	Residential 7,200 sq. ft.	SFR-Basic
15 115018 RK	R-7,200	Residential 7,200 sq. ft.	SFR-Basic
15 116154 RK	R-7,200	Residential 7,200 sq. ft.	SFR-Basic
15 116156 RK	R-7,200	Residential 7,200 sq. ft.	SFR-Basic
15 110613 RK	R-7,200	Residential 7,200 sq. ft.	SFR-Basic
15 110612 RK	R-7,200	Residential 7,200 sq. ft.	SFR-Basic
15 109442 RK	R-7,200	Residential 7,200 sq. ft.	SFR-Basic
15 110610 RK	R-7,200	Residential 7,200 sq. ft.	SFR-Basic
15 107337 RK	R-7,200	Residential 7,200 sq. ft.	SFR-Basic
15 104500 RK	R-7,200	Residential 7,200 sq. ft.	SFR-Basic
15 104498 RK	R-7,200	Residential 7,200 sq. ft.	SFR-Basic
15 114386 RK	R-7,200 : R-9,6	Residential 7,200 sq. ft. : Res	Single Family Residential
15 103523 RK	R-7,200	Residential 7,200 sq. ft.	SFR-Basic

Accessory Dwelling Units

Index # - File Name: 1.0022 - Single Family Dwellings Data\_Snohomish County.pdf

15 104502 RK	R-7,200 : R-9,600	Residential 7,200 sq. ft.	Residential SFR-Basic
15 109443 RK	R-7,200 : R-9,600	Residential 7,200 sq. ft.	Residential SFR-Basic
15 104503 RK	R-9,600	Residential 9,600 sq. ft.	SFR-Basic
15 109444 RK	R-9,600	Residential 9,600 sq. ft.	SFR-Basic
15 109445 RK	R-9,600	Residential 9,600 sq. ft.	SFR-Basic
15 103525 RK	R-9,600	Residential 9,600 sq. ft.	SFR-Basic
15 114384 RK	R-9,600	Residential 9,600 sq. ft.	Single Family Residential
15 118665 RK	R-9,600	Residential 9,600 sq. ft.	SFR-Basic
15 110615 RK	R-9,600	Residential 9,600 sq. ft.	SFR-Basic
15 103526 RK	R-9,600	Residential 9,600 sq. ft.	SFR-Basic
15 103129 RK	R-7,200 : R-9,600	Residential 7,200 sq. ft.	Residential SFR-Basic
15 103527 RK	R-7,200	Residential 7,200 sq. ft.	SFR-Basic
15 103530 RK	R-7,200	Residential 7,200 sq. ft.	SFR-Basic
15 103536 RK	R-7,200	Residential 7,200 sq. ft.	SFR-Basic
15 103534 RK	R-7,200	Residential 7,200 sq. ft.	SFR-Basic
15 103533 RK	R-7,200	Residential 7,200 sq. ft.	SFR-Basic
15 103532 RK	R-7,200	Residential 7,200 sq. ft.	SFR-Basic
15 103130 RK	R-7,200	Residential 7,200 sq. ft.	SFR-Basic
15 103128 RK	R-7,200	Residential 7,200 sq. ft.	SFR-Basic
15 103531 RK	R-7,200	Residential 7,200 sq. ft.	SFR-Basic
15 117659 RK	R-7,200	Residential 7,200 sq. ft.	SFR-Basic
15 117660 RK	R-7,200	Residential 7,200 sq. ft.	SFR-Basic
15 117661 RK	R-7,200	Residential 7,200 sq. ft.	SFR-Basic
15 115747 RK	R-7,200	Residential 7,200 sq. ft.	SFR-Basic
15 119045 RK	R-7,200	Residential 7,200 sq. ft.	SFR-Basic
15 115749 RK	R-7,200	Residential 7,200 sq. ft.	SFR-Basic
15 114439 RK	R-7,200	Residential 7,200 sq. ft.	SFR-Basic
15 114440 RK	R-7,200	Residential 7,200 sq. ft.	SFR-Basic
15 113294 RK	R-7,200	Residential 7,200 sq. ft.	SFR-Basic
15 113295 RK	R-7,200	Residential 7,200 sq. ft.	SFR-Basic
15 118279 RK	R-9,600	Residential 9,600 sq. ft.	SFR-Basic
15 118280 RK	R-9,600	Residential 9,600 sq. ft.	SFR-Basic
15 118281 RK	R-9,600	Residential 9,600 sq. ft.	SFR-Basic
15 113375 RK	R-9,600	Residential 9,600 sq. ft.	SFR-Basic
15 113376 RK	R-9,600	Residential 9,600 sq. ft.	SFR-Basic
15 115315 RK	R-9,600	Residential 9,600 sq. ft.	SFR-Basic
15 115920 RK	R-9,600	Residential 9,600 sq. ft.	SFR-Basic
15 117565 RK	R-9,600	Residential 9,600 sq. ft.	SFR-Basic
15 115921 RK	R-9,600	Residential 9,600 sq. ft.	SFR-Basic
15 115316 RK	R-9,600	Residential 9,600 sq. ft.	SFR-Basic
15 113377 RK	R-9,600	Residential 9,600 sq. ft.	SFR-Basic
15 115922 RK	R-9,600	Residential 9,600 sq. ft.	SFR-Basic
15 118282 RK	R-9,600	Residential 9,600 sq. ft.	SFR-Basic
15 115923 RK	R-9,600	Residential 9,600 sq. ft.	SFR-Basic
15 113378 RK	R-9,600	Residential 9,600 sq. ft.	SFR-Basic
15 113379 RK	R-9,600	Residential 9,600 sq. ft.	SFR-Basic
15 113380 RK	R-9,600	Residential 9,600 sq. ft.	SFR-Basic

Accessory Dwelling Units

Index # - File Name: 1.0022 - Single Family Dwellings Data\_Snohomish County.pdf

15 113381 RK	R-9,600	Residential 9,600 sq. ft.	SFR-Basic
15 113382 RK	R-9,600	Residential 9,600 sq. ft.	SFR-Basic
15 113383 RK	R-9,600	Residential 9,600 sq. ft.	SFR-Basic
15 113384 RK	R-9,600	Residential 9,600 sq. ft.	SFR-Basic
15 103628 RK	R-5	Rural-5 Acre	SFR-Basic
15 104338 RK	R-5	Rural-5 Acre	Single Family Residential
15 112386 RK	R-5	Rural-5 Acre	SFR-Basic
15 112387 RK	R-5	Rural-5 Acre	SFR-Basic
15 112388 RK	R-5	Rural-5 Acre	SFR-Basic
15 112390 RK	R-5	Rural-5 Acre	SFR-Basic
15 114239 RK	R-7,200(PRD)	Residential 7,200 sq. ft.	SFR-Basic
15 114240 RK	R-7,200(PRD)	Residential 7,200 sq. ft.	SFR-Basic
15 114241 RK	R-7,200(PRD)	Residential 7,200 sq. ft.	SFR-Basic
15 114242 RK	R-7,200(PRD)	Residential 7,200 sq. ft.	SFR-Basic
15 114243 RK	R-7,200(PRD)	Residential 7,200 sq. ft.	SFR-Basic
15 114244 RK	R-7,200(PRD)	Residential 7,200 sq. ft.	SFR-Basic
15 110581 RK	R-7,200(PRD)	Residential 7,200 sq. ft.	SFR-Basic
15 110582 RK	R-7,200(PRD)	Residential 7,200 sq. ft.	SFR-Basic
15 110583 RK	R-7,200(PRD)	Residential 7,200 sq. ft.	SFR-Basic
15 110584 RK	R-7,200(PRD)	Residential 7,200 sq. ft.	SFR-Basic
15 110585 RK	R-7,200(PRD)	Residential 7,200 sq. ft.	SFR-Basic
15 110586 RK	R-7,200(PRD)	Residential 7,200 sq. ft.	SFR-Basic
15 110587 RK	R-7,200(PRD)	Residential 7,200 sq. ft.	SFR-Basic
15 111439 RK	R-7,200(PRD)	Residential 7,200 sq. ft.	SFR-Basic
15 111440 RK	R-7,200(PRD)	Residential 7,200 sq. ft.	SFR-Basic
15 111441 RK	R-7,200(PRD)	Residential 7,200 sq. ft.	SFR-Basic
15 104131 RK	MR	Multiple Residential	Single Family Residential
15 104132 RK	MR	Multiple Residential	Single Family Residential
15 104130 RK	MR	Multiple Residential	Single Family Residential
15 104133 RK	MR	Multiple Residential	Single Family Residential
15 102871 RK	R-7,200	Residential 7,200 sq. ft.	SFR-Basic
14 111087 RK	R-5	Rural-5 Acre	Single Family Residential
15 112810 RK	R-7,200	Residential 7,200 sq. ft.	SFR-Basic
15 105850 RK	R-5	Rural-5 Acre	Single Family Residential
15 106409 RK	R-5	Rural-5 Acre	Single Family Residential
15 117776 RK	R-7,200	Residential 7,200 sq. ft.	SFR-Basic
15 108510 RK	R-5	Rural-5 Acre	Single Family Residential
15 107583 000 01 RK	R-9,600	Residential 9,600 sq. ft.	Single Family Residential
15 107385 MH	R-5	Rural-5 Acre	Double Wide
15 108831 RK	R-5	Rural-5 Acre	Single Family Residential
15 109135 RK	R-5	Rural-5 Acre	Single Family Residential
15 109528 RK	R-5	Rural-5 Acre	SFR-Basic
15 110203 RK	R-9,600	Residential 9,600 sq. ft.	Single Family Residential
15 109703 RK	R-5	Rural-5 Acre	Single Family Residential
15 110429 RK	R-5	Rural-5 Acre	Single Family Residential
15 114591 RK	NB	Neighborhood Business	Single Family Residential
15 115317 RK	NB	Neighborhood Business	Single Family Residential

Accessory Dwelling Units

Index # - File Name: 1.0022 - Single Family Dwellings Data\_Snohomish County.pdf

15 117128 RK	NB	Neighborhood Business	Single Family Residential
15 114579 RK	NB	Neighborhood Business	Single Family Residential
15 114585 RK	NB	Neighborhood Business	Single Family Residential
15 112688 RK	R-7,200	Residential 7,200 sq. ft.	SFR-Basic
15 112358 RK	R-7,200	Residential 7,200 sq. ft.	SFR-Basic
15 112359 RK	R-7,200	Residential 7,200 sq. ft.	SFR-Basic
15 112974 RK	R-7,200	Residential 7,200 sq. ft.	Single Family Residential
15 112687 RK	R-7,200	Residential 7,200 sq. ft.	SFR-Basic
15 112686 RK	R-7,200	Residential 7,200 sq. ft.	SFR-Basic
15 119497 RK	R-7,200(PRD)	Residential 7,200 sq. ft.	SFR-Basic
15 119498 RK	R-7,200(PRD)	Residential 7,200 sq. ft.	SFR-Basic
15 114587 RK	NB	Neighborhood Business	Single Family Residential
15 112309 RK	A-10	Agriculture-10 Acre	Single Family Residential
15 111428 RK	R-7,200	Residential 7,200 sq. ft.	SFR-Basic
15 118490 RK	R-7,200	Residential 7,200 sq. ft.	SFR-Basic
15 118491 RK	R-7,200	Residential 7,200 sq. ft.	SFR-Basic
15 118492 RK	R-7,200	Residential 7,200 sq. ft.	SFR-Basic
15 118493 RK	R-7,200	Residential 7,200 sq. ft.	SFR-Basic
15 118572 RK	R-8,400	Residential 8,400 sq. ft.	SFR-Basic
15 118573 RK	R-8,400	Residential 8,400 sq. ft.	SFR-Basic
15 118574 RK	R-8,400	Residential 8,400 sq. ft.	SFR-Basic
15 118575 RK	R-8,400	Residential 8,400 sq. ft.	SFR-Basic
15 115378 RK	LDMR : R-7,20 Low Density Multiple Reside SFR-Basic		
15 113538 RK	LDMR : R-7,20 Low Density Multiple Reside SFR-Basic		
15 113539 RK	LDMR : R-7,20 Low Density Multiple Reside SFR-Basic		
15 113540 RK	LDMR : R-7,20 Low Density Multiple Reside SFR-Basic		
15 115989 RK	LDMR : R-7,20 Low Density Multiple Reside SFR-Basic		
15 115990 RK	LDMR : R-7,20 Low Density Multiple Reside SFR-Basic		
15 115379 RK	LDMR : R-7,20 Low Density Multiple Reside SFR-Basic		
15 115380 RK	LDMR : R-7,20 Low Density Multiple Reside SFR-Basic		
15 115381 RK	LDMR : R-7,20 Low Density Multiple Reside SFR-Basic		
15 117863 RK	LDMR : R-7,20 Low Density Multiple Reside SFR-Basic		
15 117864 RK	LDMR : R-7,20 Low Density Multiple Reside SFR-Basic		
15 117865 RK	LDMR : R-7,20 Low Density Multiple Reside SFR-Basic		
15 113321 RK	R-5	Rural-5 Acre	Single Family Residential
15 113328 RK	R-5	Rural-5 Acre	Single Family Residential
15 113324 RK	R-5	Rural-5 Acre	Single Family Residential
15 113462 RK	R-5	Rural-5 Acre	SFR-Basic
15 115366 RK	R-9,600	Residential 9,600 sq. ft.	Duplex-Basic
15 113787 RK	R-5	Rural-5 Acre	Single Family Residential
15 115808 RK	R-7,200	Residential 7,200 sq. ft.	SFR-Basic
15 115815 RK	R-7,200	Residential 7,200 sq. ft.	SFR-Basic
15 115810 RK	R-7,200	Residential 7,200 sq. ft.	SFR-Basic
15 115813 RK	R-7,200	Residential 7,200 sq. ft.	SFR-Basic
15 114746 RK	R-7,200	Residential 7,200 sq. ft.	Single Family Residential
15 115847 RK	LDMR	Low Density Multiple Reside	SFR-Basic
15 115855 RK	LDMR	Low Density Multiple Reside	SFR-Basic

Accessory Dwelling Units

Index # - File Name: 1.0022 - Single Family Dwellings Data\_Snohomish County.pdf

15 115859 RK	LDMR	Low Density Multiple Reside	SFR-Basic
15 117668 RK	R-7,200(PRD)	Residential 7,200 sq. ft.	SFR-Basic
15 117674 RK	R-7,200(PRD)	Residential 7,200 sq. ft.	SFR-Basic
15 117669 RK	R-7,200(PRD)	Residential 7,200 sq. ft.	SFR-Basic
15 114472 RK	R-5	Rural-5 Acre	SFR-Basic
15 115627 RK	R-5	Rural-5 Acre	Single Family Residential
15 118179 RK	LDMR	Low Density Multiple Reside	SFR-Basic
15 114012 RK	R-7,200	Residential 7,200 sq. ft.	SFR-Basic
15 118678 RK	R-8,400 : R-9,600	Residential 8,400 sq. ft. : Res	SFR-Basic
14 112673 RK	F	Forestry	Single Family Residential
15 107514 RK	R-5	Rural-5 Acre	Single Family Residential
14 116474 RK	R-5	Rural-5 Acre	Single Family Residential
15 107142 RK	R-7,200	Residential 7,200 sq. ft.	SFR-Basic
15 107110 RK	R-7,200	Residential 7,200 sq. ft.	SFR-Basic
15 107111 RK	R-7,200	Residential 7,200 sq. ft.	SFR-Basic
15 107112 RK	R-7,200	Residential 7,200 sq. ft.	SFR-Basic
15 107113 RK	R-7,200	Residential 7,200 sq. ft.	SFR-Basic
15 107114 RK	R-7,200	Residential 7,200 sq. ft.	SFR-Basic
15 112397 RK	R-7,200	Residential 7,200 sq. ft.	SFR-Basic
15 112398 RK	R-7,200	Residential 7,200 sq. ft.	SFR-Basic
15 115975 RK	R-5	Rural-5 Acre	Single Family Residential
15 106703 RK	R-5	Rural-5 Acre	SFR-Basic
15 102324 RK	R-5	Rural-5 Acre	SFR-Basic
15 102323 RK	R-5	Rural-5 Acre	SFR-Basic
15 103114 RK	R-5	Rural-5 Acre	Single Family Residential
14 113410 RK	R-5	Rural-5 Acre	Single Family Residential
15 118334 RK	R-5	Rural-5 Acre	Single Family Residential
15 110327 RK	A-10	Agriculture-10 Acre	Single Family Residential
15 100140 RK	R-9,600	Residential 9,600 sq. ft.	Single Family Residential
15 111164 RK	R-7,200	Residential 7,200 sq. ft.	SFR-Basic
15 110393 RK	R-7,200	Residential 7,200 sq. ft.	SFR-Basic
15 112945 RK	R-7,200	Residential 7,200 sq. ft.	SFR-Basic
15 111431 RK	R-7,200	Residential 7,200 sq. ft.	SFR-Basic
15 115370 RK	R-7,200	Residential 7,200 sq. ft.	SFR-Basic
15 106874 RK	R-7,200	Residential 7,200 sq. ft.	SFR-Basic
15 106428 RK	R-7,200	Residential 7,200 sq. ft.	SFR-Basic
15 105337 RK	R-7,200	Residential 7,200 sq. ft.	SFR-Basic
14 116172 RK	R-7,200	Residential 7,200 sq. ft.	SFR-Basic
15 106112 RK	R-7,200	Residential 7,200 sq. ft.	SFR-Basic
15 101924 RK	R-7,200	Residential 7,200 sq. ft.	SFR-Basic
14 113531 RK	R-7,200	Residential 7,200 sq. ft.	SFR-Basic
15 105335 RK	R-7,200	Residential 7,200 sq. ft.	SFR-Basic
15 107201 RK	R-7,200	Residential 7,200 sq. ft.	SFR-Basic
15 103079 RK	R-7,200	Residential 7,200 sq. ft.	SFR-Basic
15 103080 RK	R-7,200	Residential 7,200 sq. ft.	SFR-Basic
15 103081 RK	R-7,200	Residential 7,200 sq. ft.	SFR-Basic
15 106427 RK	R-7,200	Residential 7,200 sq. ft.	SFR-Basic

Accessory Dwelling Units

Index # - File Name: 1.0022 - Single Family Dwellings Data\_Snohomish County.pdf

15 106114 RK	R-7,200	Residential 7,200 sq. ft.	SFR-Basic
15 106115 RK	R-7,200	Residential 7,200 sq. ft.	SFR-Basic
15 105336 RK	R-7,200	Residential 7,200 sq. ft.	SFR-Basic
15 112946 RK	R-7,200	Residential 7,200 sq. ft.	SFR-Basic
15 111382 RK	R-7,200	Residential 7,200 sq. ft.	SFR-Basic
15 108516 RK	R-7,200	Residential 7,200 sq. ft.	SFR-Basic
15 113517 RK	R-7,200	Residential 7,200 sq. ft.	SFR-Basic
15 111165 RK	R-7,200	Residential 7,200 sq. ft.	SFR-Basic
15 110394 RK	R-7,200	Residential 7,200 sq. ft.	SFR-Basic
15 113199 RK	R-5	Rural-5 Acre	SFR-Basic
15 113195 RK	R-5	Rural-5 Acre	SFR-Basic
15 113197 RK	R-5	Rural-5 Acre	Single Family Residential
15 113201 RK	R-5	Rural-5 Acre	SFR-Basic
15 106126 RK	R-8,400	Residential 8,400 sq. ft.	Single Family Residential
15 107321 RK	R-7,200	Residential 7,200 sq. ft.	SFR-Basic
15 114435 RK	R-7,200	Residential 7,200 sq. ft.	SFR-Basic
15 111372 RK	R-5	Rural-5 Acre	Single Family Residential
15 108789 RK	R-5	Rural-5 Acre	SFR-Basic
15 103497 RK	R-5	Rural-5 Acre	SFR-Basic
15 108788 RK	R-5	Rural-5 Acre	SFR-Basic
15 106952 RK	R-5	Rural-5 Acre	SFR-Basic
15 104025 RK	R-5	Rural-5 Acre	SFR-Basic
14 115483 RK	R-5	Rural-5 Acre	Single Family Residential
14 115486 RK	R-5	Rural-5 Acre	Single Family Residential
15 102352 RK	R-5	Rural-5 Acre	Single Family Residential
15 106136 RK	R-5	Rural-5 Acre	SFR-Basic
15 104020 RK	R-5	Rural-5 Acre	SFR-Basic
15 101181 RK	R-5	Rural-5 Acre	SFR-Basic
15 102745 RK	R-7,200	Residential 7,200 sq. ft.	SFR-Basic
15 102746 RK	R-7,200	Residential 7,200 sq. ft.	SFR-Basic
15 102747 RK	R-7,200	Residential 7,200 sq. ft.	SFR-Basic
15 102748 RK	R-7,200	Residential 7,200 sq. ft.	SFR-Basic
15 102749 RK	R-7,200	Residential 7,200 sq. ft.	SFR-Basic
15 102750 RK	R-7,200	Residential 7,200 sq. ft.	SFR-Basic
15 102751 RK	R-7,200	Residential 7,200 sq. ft.	SFR-Basic
15 102752 RK	R-7,200	Residential 7,200 sq. ft.	SFR-Basic
15 102753 RK	R-7,200	Residential 7,200 sq. ft.	SFR-Basic
15 102754 RK	R-7,200	Residential 7,200 sq. ft.	SFR-Basic
15 102755 RK	R-7,200	Residential 7,200 sq. ft.	SFR-Basic
15 101424 RK	R-7,200	Residential 7,200 sq. ft.	SFR-Basic
15 101425 RK	R-7,200	Residential 7,200 sq. ft.	SFR-Basic
15 101426 RK	R-7,200	Residential 7,200 sq. ft.	SFR-Basic
14 116337 RK	R-7,200	Residential 7,200 sq. ft.	SFR-Basic
14 116338 RK	R-7,200	Residential 7,200 sq. ft.	SFR-Basic
14 116339 RK	R-7,200	Residential 7,200 sq. ft.	SFR-Basic
14 116319 RK	R-7,200	Residential 7,200 sq. ft.	SFR-Basic
14 116320 RK	R-7,200	Residential 7,200 sq. ft.	SFR-Basic

Accessory Dwelling Units

Index # - File Name: 1.0022 - Single Family Dwellings Data\_Snohomish County.pdf

14 116193 RK	R-7,200	Residential 7,200 sq. ft.	SFR-Basic
15 103809 RK	R-7,200	Residential 7,200 sq. ft.	SFR-Basic
14 116318 RK	R-7,200	Residential 7,200 sq. ft.	SFR-Basic
14 116321 RK	R-7,200	Residential 7,200 sq. ft.	SFR-Basic
15 102743 RK	R-5	Rural-5 Acre	SFR-Basic
15 102375 RK	R-5	Rural-5 Acre	SFR-Basic
15 102376 RK	R-5	Rural-5 Acre	SFR-Basic
15 104320 RK	R-5	Rural-5 Acre	SFR-Basic
15 104322 RK	R-5	Rural-5 Acre	SFR-Basic
15 104323 RK	R-5	Rural-5 Acre	SFR-Basic
15 106638 RK	R-5	Rural-5 Acre	SFR-Basic
15 106637 RK	R-5	Rural-5 Acre	SFR-Basic
15 116435 RK	R-5	Rural-5 Acre	SFR-Basic
15 104324 RK	R-5	Rural-5 Acre	SFR-Basic
15 104326 RK	R-5	Rural-5 Acre	SFR-Basic
15 118268 RK	R-5	Rural-5 Acre	SFR-Basic
14 113618 RK	R-5	Rural-5 Acre	Single Family Residential
15 104613 RK	R-7,200	Residential 7,200 sq. ft.	Single Family Residential
14 116190 RK	R-7,200	Residential 7,200 sq. ft.	SFR-Basic
15 101440 RK	R-7,200	Residential 7,200 sq. ft.	SFR-Basic
15 102519 RK	R-7,200	Residential 7,200 sq. ft.	SFR-Basic
14 116191 RK	R-7,200	Residential 7,200 sq. ft.	SFR-Basic
14 116192 RK	R-7,200	Residential 7,200 sq. ft.	SFR-Basic
14 116317 RK	R-7,200	Residential 7,200 sq. ft.	SFR-Basic
15 102520 RK	R-7,200	Residential 7,200 sq. ft.	SFR-Basic
15 102521 RK	R-7,200	Residential 7,200 sq. ft.	SFR-Basic
14 116322 RK	R-7,200	Residential 7,200 sq. ft.	SFR-Basic
14 116189 RK	R-7,200	Residential 7,200 sq. ft.	SFR-Basic
14 112255 RK	R-7,200(PRD)	Residential 7,200 sq. ft.	SFR-Basic
14 115837 RK	R-7,200(PRD)	Residential 7,200 sq. ft.	SFR-Basic
14 115838 RK	R-7,200(PRD)	Residential 7,200 sq. ft.	SFR-Basic
15 103816 RK	R-7,200(PRD)	Residential 7,200 sq. ft.	SFR-Basic
15 109603 RK	R-7,200(PRD)	Residential 7,200 sq. ft.	SFR-Basic
15 100925 RK	R-7,200(PRD)	Residential 7,200 sq. ft.	SFR-Basic
15 112546 RK	R-7,200(PRD)	Residential 7,200 sq. ft.	SFR-Basic
15 114530 RK	R-7,200(PRD)	Residential 7,200 sq. ft.	SFR-Basic
15 100927 RK	R-7,200(PRD)	Residential 7,200 sq. ft.	SFR-Basic
15 114532 RK	R-7,200(PRD)	Residential 7,200 sq. ft.	SFR-Basic
15 100926 RK	R-7,200(PRD)	Residential 7,200 sq. ft.	SFR-Basic
15 107349 RK	R-7,200(PRD)	Residential 7,200 sq. ft.	SFR-Basic
15 106527 RK	R-7,200(PRD)	Residential 7,200 sq. ft.	SFR-Basic
15 107350 RK	R-7,200(PRD)	Residential 7,200 sq. ft.	SFR-Basic
15 103815 RK	R-7,200(PRD)	Residential 7,200 sq. ft.	SFR-Basic
15 100928 RK	R-7,200(PRD)	Residential 7,200 sq. ft.	SFR-Basic
15 106530 RK	R-7,200(PRD)	Residential 7,200 sq. ft.	SFR-Basic
14 112253 RK	R-7,200(PRD)	Residential 7,200 sq. ft.	SFR-Basic
14 112599 RK	R-7,200(PRD)	Residential 7,200 sq. ft.	Single Family Residential



Accessory Dwelling Units

Index # - File Name: 1.0022 - Single Family Dwellings Data\_Snohomish County.pdf

14 115836 RK	R-7,200(PRD)	Residential 7,200 sq. ft.	SFR-Basic
14 112252 RK	R-7,200(PRD)	Residential 7,200 sq. ft.	SFR-Basic
15 107160 RK	R-7,200(PRD)	Residential 7,200 sq. ft.	SFR-Basic
15 110400 RK	R-7,200	Residential 7,200 sq. ft.	Single Family Residential
14 110057 RK	R-5	Rural-5 Acre	Single Family Residential
14 115793 RK			SFR-Basic
15 100739 RK	R-7,200	Residential 7,200 sq. ft.	SFR-Basic
15 100740 RK	R-7,200	Residential 7,200 sq. ft.	SFR-Basic
14 115825 RK	R-7,200	Residential 7,200 sq. ft.	SFR-Basic
14 113619 RK	R-7,200	Residential 7,200 sq. ft.	SFR-Basic
15 100738 RK	R-7,200	Residential 7,200 sq. ft.	SFR-Basic
15 100382 RK	R-7,200	Residential 7,200 sq. ft.	SFR-Basic
15 100383 RK	R-7,200	Residential 7,200 sq. ft.	SFR-Basic
15 100384 RK	R-7,200	Residential 7,200 sq. ft.	SFR-Basic
15 100385 000 01 RK	R-7,200	Residential 7,200 sq. ft.	SFR-Basic
15 109150 RK	R-7,200	Residential 7,200 sq. ft.	Single Family Residential
15 109152 RK	R-7,200	Residential 7,200 sq. ft.	Single Family Residential
15 114885 RK	R-7,200	Residential 7,200 sq. ft.	Single Family Residential
15 114420 RK	R-7,200	Residential 7,200 sq. ft.	SFR-Basic
15 115658 RK	R-7,200	Residential 7,200 sq. ft.	Single Family Residential
15 114421 RK	R-7,200	Residential 7,200 sq. ft.	SFR-Basic
15 114887 RK	R-7,200	Residential 7,200 sq. ft.	Single Family Residential
15 100388 RK	R-7,200	Residential 7,200 sq. ft.	SFR-Basic
15 115884 RK	R-7,200	Residential 7,200 sq. ft.	Single Family Residential
15 106119 RK	R-7,200	Residential 7,200 sq. ft.	SFR-Basic
15 115452 RK	R-7,200	Residential 7,200 sq. ft.	Single Family Residential
15 106120 RK	R-7,200	Residential 7,200 sq. ft.	SFR-Basic
15 109446 RK	R-7,200	Residential 7,200 sq. ft.	Single Family Residential
15 109449 RK	R-7,200	Residential 7,200 sq. ft.	Single Family Residential
15 111188 RK	R-7,200	Residential 7,200 sq. ft.	Single Family Residential
15 110031 RK	R-7,200	Residential 7,200 sq. ft.	Single Family Residential
15 109544 RK	R-7,200	Residential 7,200 sq. ft.	Single Family Residential
15 111189 RK	R-7,200	Residential 7,200 sq. ft.	Single Family Residential
15 107071 RK	R-7,200	Residential 7,200 sq. ft.	SFR-Basic
15 107072 RK	R-7,200	Residential 7,200 sq. ft.	SFR-Basic
15 110503 RK	R-7,200	Residential 7,200 sq. ft.	Single Family Residential
15 115451 RK	R-7,200	Residential 7,200 sq. ft.	Single Family Residential
15 109743 RK	R-7,200	Residential 7,200 sq. ft.	Single Family Residential
15 115495 RK	R-7,200	Residential 7,200 sq. ft.	Single Family Residential
15 115322 RK	R-7,200	Residential 7,200 sq. ft.	Single Family Residential
15 115494 RK	R-7,200	Residential 7,200 sq. ft.	Single Family Residential
15 109175 RK	R-7,200	Residential 7,200 sq. ft.	SFR-Basic
15 115582 RK	R-7,200	Residential 7,200 sq. ft.	Single Family Residential
15 115581 RK	R-7,200	Residential 7,200 sq. ft.	Single Family Residential
15 115657 RK	R-7,200	Residential 7,200 sq. ft.	Single Family Residential
15 108828 RK	R-5	Rural-5 Acre	Single Family Residential
15 103084 RK	R-5	Rural-5 Acre	Single Family Residential

Accessory Dwelling Units

Index # - File Name: 1.0022 - Single Family Dwellings Data\_Snohomish County.pdf

15 105433 RK	R-5	Rural-5 Acre	Single Family Residential
15 106726 RK	R-5	Rural-5 Acre	Single Family Residential
15 114803 RK	R-9,600	Residential 9,600 sq. ft.	SFR-Basic
14 115310 RK	R-9,600	Residential 9,600 sq. ft.	SFR-Basic
14 115309 RK	R-9,600	Residential 9,600 sq. ft.	SFR-Basic
15 108716 RK	R-9,600	Residential 9,600 sq. ft.	Single Family Residential
15 107458 RK	R-9,600	Residential 9,600 sq. ft.	SFR-Basic
15 107277 RK	R-9,600	Residential 9,600 sq. ft.	SFR-Basic
15 107279 RK	R-9,600	Residential 9,600 sq. ft.	SFR-Basic
15 112784 RK	R-9,600	Residential 9,600 sq. ft.	SFR-Basic
15 113655 RK	R-9,600	Residential 9,600 sq. ft.	SFR-Basic
15 113653 RK	R-9,600	Residential 9,600 sq. ft.	SFR-Basic
15 103911 RK	R-5	Rural-5 Acre	Single Family Residential
15 100386 RK	R-7,200	Residential 7,200 sq. ft.	SFR-Basic
15 100387 RK	R-7,200	Residential 7,200 sq. ft.	SFR-Basic
15 100389 RK	R-7,200	Residential 7,200 sq. ft.	SFR-Basic
15 100390 RK	R-7,200	Residential 7,200 sq. ft.	SFR-Basic
15 100391 RK	R-7,200	Residential 7,200 sq. ft.	SFR-Basic
15 100392 RK	R-7,200	Residential 7,200 sq. ft.	SFR-Basic
15 107073 RK	R-7,200	Residential 7,200 sq. ft.	SFR-Basic
15 115323 RK	R-7,200	Residential 7,200 sq. ft.	Single Family Residential
15 115026 RK	R-7,200	Residential 7,200 sq. ft.	Single Family Residential
15 112786 RK	R-9,600	Residential 9,600 sq. ft.	SFR-Basic
15 106461 RK	R-7,200	Residential 7,200 sq. ft.	SFR-Basic
15 115447 RK	R-7,200	Residential 7,200 sq. ft.	SFR-Basic
15 114302 RK	R-7,200	Residential 7,200 sq. ft.	SFR-Basic
15 114093 RK	R-7,200	Residential 7,200 sq. ft.	SFR-Basic
15 114303 RK	R-7,200	Residential 7,200 sq. ft.	SFR-Basic
14 115563 RK	R-9,600	Residential 9,600 sq. ft.	SFR-Basic
14 115561 RK	R-9,600	Residential 9,600 sq. ft.	SFR-Basic
14 115558 RK	R-9,600	Residential 9,600 sq. ft.	SFR-Basic
14 115557 RK	R-9,600	Residential 9,600 sq. ft.	SFR-Basic
14 115556 RK	R-9,600	Residential 9,600 sq. ft.	SFR-Basic
14 115555 RK	R-9,600	Residential 9,600 sq. ft.	SFR-Basic
14 116391 RK	R-9,600	Residential 9,600 sq. ft.	SFR-Basic
14 116392 RK	R-9,600	Residential 9,600 sq. ft.	SFR-Basic
15 107275 RK	R-9,600	Residential 9,600 sq. ft.	SFR-Basic
14 116394 RK	R-9,600	Residential 9,600 sq. ft.	SFR-Basic
14 116395 RK	R-9,600	Residential 9,600 sq. ft.	SFR-Basic
14 116396 RK	R-9,600	Residential 9,600 sq. ft.	SFR-Basic
15 106708 RK	R-9,600	Residential 9,600 sq. ft.	SFR-Basic
15 107276 RK	R-9,600	Residential 9,600 sq. ft.	SFR-Basic
15 106709 RK	R-9,600	Residential 9,600 sq. ft.	SFR-Basic
15 106810 RK	R-9,600	Residential 9,600 sq. ft.	SFR-Basic
15 106154 RK	R-9,600	Residential 9,600 sq. ft.	SFR-Basic
14 115118 RK	R-9,600	Residential 9,600 sq. ft.	SFR-Basic
15 106052 RK	R-5	Rural-5 Acre	Single Family Residential

Accessory Dwelling Units

Index # - File Name: 1.0022 - Single Family Dwellings Data\_Snohomish County.pdf

15 109143 RK	R-5	Rural-5 Acre	Single Family Residential
15 105845 RK	R-5	Rural-5 Acre	Single Family Residential
15 101466 RK	R-5	Rural-5 Acre	SFR-Basic
15 106111 RK	R-7,200(PRD)	Residential 7,200 sq. ft.	SFR-Basic
15 102551 RK	R-7,200(PRD)	Residential 7,200 sq. ft.	SFR-Basic
15 101267 RK	R-7,200(PRD)	Residential 7,200 sq. ft.	SFR-Basic
15 101268 RK	R-7,200(PRD)	Residential 7,200 sq. ft.	SFR-Basic
15 101925 RK	R-7,200	Residential 7,200 sq. ft.	SFR-Basic
15 107322 RK	R-7,200	Residential 7,200 sq. ft.	SFR-Basic
15 106113 RK	R-7,200	Residential 7,200 sq. ft.	SFR-Basic
14 113418 RK	R-7,200	Residential 7,200 sq. ft.	SFR-Basic
15 108568 RK	R-5	Rural-5 Acre	Single Family Residential
15 106295 RK	R-7,200	Residential 7,200 sq. ft.	Single Family Residential
15 109806 RK	R-5	Rural-5 Acre	Single Family Residential
15 112768 RK	R-5	Rural-5 Acre	Single Family Residential
14 110782 RK	R-7,200	Residential 7,200 sq. ft.	Single Family Residential
14 113792 RK	R-7,200	Residential 7,200 sq. ft.	SFR-Basic
14 113793 RK	R-7,200	Residential 7,200 sq. ft.	SFR-Basic
14 113794 RK	R-7,200	Residential 7,200 sq. ft.	SFR-Basic
14 113796 RK	R-7,200	Residential 7,200 sq. ft.	SFR-Basic
14 110784 RK	R-7,200	Residential 7,200 sq. ft.	Single Family Residential
15 102790 RK	R-7,200	Residential 7,200 sq. ft.	Single Family Residential
14 114512 RK	R-8,400	Residential 8,400 sq. ft.	SFR-Basic
15 113709 000 01 RK	R-5	Rural-5 Acre	Single Family Residential
15 106361 RK	R-5	Rural-5 Acre	Single Family Residential
15 106363 RK	R-5	Rural-5 Acre	Single Family Residential
15 102791 RK	R-7,200	Residential 7,200 sq. ft.	SFR-Basic
15 106116 RK	R-8,400	Residential 8,400 sq. ft.	SFR-Basic
15 106528 RK	R-8,400	Residential 8,400 sq. ft.	SFR-Basic
15 104396 RK	R-8,400	Residential 8,400 sq. ft.	Single Family Residential
15 103314 RK	R-8,400	Residential 8,400 sq. ft.	SFR-Basic
15 102674 RK	R-8,400	Residential 8,400 sq. ft.	SFR-Basic
15 103315 RK	R-8,400	Residential 8,400 sq. ft.	SFR-Basic
15 103316 RK	R-8,400	Residential 8,400 sq. ft.	SFR-Basic
15 103317 RK	R-8,400	Residential 8,400 sq. ft.	SFR-Basic
15 104397 RK	R-8,400	Residential 8,400 sq. ft.	Single Family Residential
15 103318 RK	R-8,400	Residential 8,400 sq. ft.	SFR-Basic
14 112429 RK	R-8,400	Residential 8,400 sq. ft.	SFR-Basic
14 112430 RK	R-8,400	Residential 8,400 sq. ft.	SFR-Basic
15 104577 RK	R-8,400	Residential 8,400 sq. ft.	SFR-Basic
15 102672 RK	R-8,400	Residential 8,400 sq. ft.	SFR-Basic
15 102673 RK	R-8,400	Residential 8,400 sq. ft.	SFR-Basic
15 101269 RK	R-7,200(PRD)	Residential 7,200 sq. ft.	SFR-Basic
15 101270 RK	R-7,200(PRD)	Residential 7,200 sq. ft.	SFR-Basic
14 116179 RK	R-7,200(PRD)	Residential 7,200 sq. ft.	SFR-Basic
14 114218 RK	R-9,600	Residential 9,600 sq. ft.	SFR-Basic
14 114219 RK	R-9,600	Residential 9,600 sq. ft.	SFR-Basic

Accessory Dwelling Units

Index # - File Name: 1.0022 - Single Family Dwellings Data\_Snohomish County.pdf

15 105477 RK	R-7,200(PRD)	Residential 7,200 sq. ft.	SFR-Basic
15 105478 RK	R-7,200(PRD)	Residential 7,200 sq. ft.	SFR-Basic
15 102734 000 01 RK	R-5	Rural-5 Acre	Single Family Residential
15 106898 RK	R-7,200(PRD)	Residential 7,200 sq. ft.	SFR-Basic
15 107161 RK	R-7,200(PRD)	Residential 7,200 sq. ft.	SFR-Basic
15 102587 RK	R-5	Rural-5 Acre	Single Family Residential
15 114575 RK	R-5	Rural-5 Acre	Single Family Residential
15 109841 RK	MR	Multiple Residential	Single Family Residential
15 101611 RK	MR	Multiple Residential	Single Family Residential
14 116158 RK	R-5	Rural-5 Acre	Single Family Residential
15 106284 MH	RRT-10	Rural Resource Transition-10	Double Wide
15 109917 RK	R-5	Rural-5 Acre	SFR-Basic
15 115646 RK	R-5	Rural-5 Acre	SFR-Basic
15 101487 RK	R-5	Rural-5 Acre	Single Family Residential
15 101182 RK	R-5	Rural-5 Acre	SFR-Basic
14 115049 RK	R-5	Rural-5 Acre	SFR-Basic
15 101184 RK	R-5	Rural-5 Acre	SFR-Basic
14 115051 RK	R-5	Rural-5 Acre	SFR-Basic
15 109918 RK	R-5	Rural-5 Acre	SFR-Basic
15 107293 MH	RD	Rural Diversification	Double Wide
15 102416 000 01 RK	R-5	Rural-5 Acre	Single Family Residential
15 112696 RK	R-5	Rural-5 Acre	Single Family Residential
15 100070 RK	R-5	Rural-5 Acre	Single Family Residential
15 110230 000 01 RK	R-5	Rural-5 Acre	Accessory Apt Detached
16 111079 RK	R-5	Rural-5 Acre	Single Family Residential
15 119185 RK	R-7,200	Residential 7,200 sq. ft.	SFR-Basic
15 119186 RK	R-7,200	Residential 7,200 sq. ft.	SFR-Basic
15 119187 RK	R-7,200	Residential 7,200 sq. ft.	SFR-Basic
15 117571 RK	R-5	Rural-5 Acre	Single Family Residential
15 117573 RK	R-5	Rural-5 Acre	Single Family Residential
16 103677 RK	R-5	Rural-5 Acre	Single Family Residential
16 103673 RK	R-5	Rural-5 Acre	Single Family Residential
16 107572 RK	R-5	Rural-5 Acre	Single Family Residential
16 107573 000 01 RK	R-5	Rural-5 Acre	Single Family Residential
16 102150 RK	R-7,200	Residential 7,200 sq. ft.	Single Family Residential
15 117056 000 01 RK	R-9,600	Residential 9,600 sq. ft.	Single Family Residential
16 108681 RK	R-5	Rural-5 Acre	Single Family Residential
16 108741 RK	R-5	Rural-5 Acre	SFR-Basic
16 106394 RK	R-5	Rural-5 Acre	Single Family Residential
16 106751 RK	R-5	Rural-5 Acre	SFR-Basic
15 119886 RK	R-5	Rural-5 Acre	Single Family Residential
16 106752 RK	R-5	Rural-5 Acre	SFR-Basic
16 108973 RK	R-5	Rural-5 Acre	SFR-Basic
16 101976 RK	R-5	Rural-5 Acre	SFR-Basic
16 103064 RK	R-5	Rural-5 Acre	Single Family Residential
16 108387 RK	R-5	Rural-5 Acre	SFR-Basic
16 113312 RK	R-5	Rural-5 Acre	Single Family Residential

Accessory Dwelling Units

Index # - File Name: 1.0022 - Single Family Dwellings Data\_Snohomish County.pdf

16 113303 RK	R-5	Rural-5 Acre	Single Family Residential
16 108990 RK	R-5	Rural-5 Acre	Single Family Residential
15 117502 RK	R-5	Rural-5 Acre	Single Family Residential
15 117505 RK	R-5	Rural-5 Acre	Accessory Apt Detached
16 110578 RK	R-5	Rural-5 Acre	Single Family Residential
16 113368 RK	R-5	Rural-5 Acre	Single Family Residential
16 117726 RK	R-5	Rural-5 Acre	Single Family Residential
16 103457 RK	R-5	Rural-5 Acre	SFR-Basic
16 109837 RK	R-5	Rural-5 Acre	Single Family Residential
16 108552 RK	R-5	Rural-5 Acre	Single Family Residential
16 108554 RK	R-5	Rural-5 Acre	Single Family Residential
16 110575 RK	R-5	Rural-5 Acre	Single Family Residential
16 110577 RK	R-5	Rural-5 Acre	Single Family Residential
16 105041 RK	R-5	Rural-5 Acre	Single Family Residential
15 118646 RK	R-7,200	Residential 7,200 sq. ft.	Accessory Apt Detached
16 101422 RK	R-7,200(PRD)	Residential 7,200 sq. ft.	SFR-Basic
16 101423 RK	R-7,200(PRD)	Residential 7,200 sq. ft.	SFR-Basic
16 101424 RK	R-7,200(PRD)	Residential 7,200 sq. ft.	SFR-Basic
16 111192 RK	R-7,200(PRD)	Residential 7,200 sq. ft.	SFR-Basic
15 115611 RK	R-5	Rural-5 Acre	Single Family Residential
16 111189 RK	R-7,200(PRD)	Residential 7,200 sq. ft.	SFR-Basic
16 111190 RK	R-7,200(PRD)	Residential 7,200 sq. ft.	SFR-Basic
16 111191 RK	R-7,200(PRD)	Residential 7,200 sq. ft.	SFR-Basic
16 101015 RK	R-5	Rural-5 Acre	Duplex
16 111193 RK	R-7,200(PRD)	Residential 7,200 sq. ft.	SFR-Basic
16 111194 RK	R-7,200(PRD)	Residential 7,200 sq. ft.	SFR-Basic
16 111195 RK	R-7,200(PRD)	Residential 7,200 sq. ft.	SFR-Basic
16 111196 RK	R-7,200(PRD)	Residential 7,200 sq. ft.	SFR-Basic
16 111197 RK	R-7,200(PRD)	Residential 7,200 sq. ft.	SFR-Basic
16 111198 RK	R-7,200(PRD)	Residential 7,200 sq. ft.	SFR-Basic
16 111199 RK	R-7,200(PRD)	Residential 7,200 sq. ft.	SFR-Basic
16 111200 RK	R-7,200(PRD)	Residential 7,200 sq. ft.	SFR-Basic
16 111201 RK	R-7,200(PRD)	Residential 7,200 sq. ft.	SFR-Basic
16 111202 RK	R-7,200(PRD)	Residential 7,200 sq. ft.	SFR-Basic
16 108677 RK	R-5	Rural-5 Acre	Single Family Residential
16 101381 RK	R-9,600	Residential 9,600 sq. ft.	SFR-Basic
15 108987 RK	R-9,600	Residential 9,600 sq. ft.	SFR-Basic
15 108985 RK	R-9,600	Residential 9,600 sq. ft.	SFR-Basic
16 102912 RK	R-7,200	Residential 7,200 sq. ft.	Single Family Residential
16 102977 RK	R-7,200	Residential 7,200 sq. ft.	Single Family Residential
16 102978 RK	R-7,200	Residential 7,200 sq. ft.	Single Family Residential
15 115880 RK	R-7,200	Residential 7,200 sq. ft.	SFR-Basic
16 107692 RK	R-9,600	Residential 9,600 sq. ft.	SFR-Basic
16 102913 RK	R-7,200	Residential 7,200 sq. ft.	Single Family Residential
16 114737 RK	R-7,200	Residential 7,200 sq. ft.	Single Family Residential
16 116133 RK	R-7,200	Residential 7,200 sq. ft.	Single Family Residential
15 114805 RK	R-9,600	Residential 9,600 sq. ft.	SFR-Basic

Accessory Dwelling Units

Index # - File Name: 1.0022 - Single Family Dwellings Data\_Snohomish County.pdf

15 108988 RK	R-9,600	Residential 9,600 sq. ft.	SFR-Basic
15 113656 RK	R-9,600	Residential 9,600 sq. ft.	Single Family Residential
15 107278 RK	R-9,600	Residential 9,600 sq. ft.	SFR-Basic
16 109150 000 01 RK	R-5	Rural-5 Acre	Single Family Residential
16 108471 RK	R-7,200	Residential 7,200 sq. ft.	Single Family Residential
16 114061 RK	R-7,200	Residential 7,200 sq. ft.	Single Family Residential
16 114421 RK	R-7,200	Residential 7,200 sq. ft.	Single Family Residential
16 103618 RK	R-7,200	Residential 7,200 sq. ft.	Single Family Residential
16 105167 RK	R-7,200	Residential 7,200 sq. ft.	Single Family Residential
16 106156 RK	R-7,200(PRD)	Residential 7,200 sq. ft.	SFR-Basic
16 118202 RK	R-7,200(PRD)	Residential 7,200 sq. ft.	Single Family Residential
16 106157 RK	R-7,200(PRD)	Residential 7,200 sq. ft.	SFR-Basic
16 104017 RK	R-7,200(PRD)	Residential 7,200 sq. ft.	SFR-Basic
16 104015 RK	R-7,200(PRD)	Residential 7,200 sq. ft.	SFR-Basic
16 100850 RK	R-7,200(PRD)	Residential 7,200 sq. ft.	SFR-Basic
15 119700 RK	R-7,200(PRD)	Residential 7,200 sq. ft.	SFR-Basic
16 100847 RK	R-7,200(PRD)	Residential 7,200 sq. ft.	SFR-Basic
16 100851 RK	R-7,200(PRD)	Residential 7,200 sq. ft.	SFR-Basic
15 119698 RK	R-7,200(PRD)	Residential 7,200 sq. ft.	SFR-Basic
16 106154 RK	R-7,200(PRD)	Residential 7,200 sq. ft.	SFR-Basic
14 107792 RK	WFB	Waterfront Beach	SFR-Basic
16 109799 RK	R-5	Rural-5 Acre	SFR-Basic
16 109286 RK	R-5	Rural-5 Acre	SFR-Basic
16 109289 RK	R-5	Rural-5 Acre	SFR-Basic
16 109290 RK	R-5	Rural-5 Acre	SFR-Basic
16 108050 RK	R-5	Rural-5 Acre	Single Family Residential
15 108995 RK	R-5	Rural-5 Acre	Single Family Residential
15 117470 RK	R-5	Rural-5 Acre	Single Family Residential
15 106170 RK	R-5	Rural-5 Acre	Single Family Residential
16 100306 RK	R-5	Rural-5 Acre	Single Family Residential
16 104274 RK	R-8,400 : R-9,600	Residential 8,400 sq. ft. : Residential 9,600 sq. ft.	SFR-Basic
16 104280 RK	R-8,400 : R-9,600	Residential 8,400 sq. ft. : Residential 9,600 sq. ft.	SFR-Basic
16 104272 RK	R-8,400 : R-9,600	Residential 8,400 sq. ft. : Residential 9,600 sq. ft.	SFR-Basic
15 118915 RK	R-5	Rural-5 Acre	Single Family Residential
16 114492 RK	R-7,200	Residential 7,200 sq. ft.	SFR-Basic
16 114497 RK	R-7,200	Residential 7,200 sq. ft.	SFR-Basic
16 114498 RK	R-7,200	Residential 7,200 sq. ft.	SFR-Basic
16 114499 RK	R-7,200	Residential 7,200 sq. ft.	SFR-Basic
16 114496 RK	R-7,200	Residential 7,200 sq. ft.	SFR-Basic
16 114500 RK	R-7,200	Residential 7,200 sq. ft.	SFR-Basic
16 118357 RK	R-9,600	Residential 9,600 sq. ft.	Single Family Residential
16 120465 RK	R-9,600	Residential 9,600 sq. ft.	Single Family Residential
16 118280 RK	R-9,600	Residential 9,600 sq. ft.	Single Family Residential
16 120470 RK	R-9,600	Residential 9,600 sq. ft.	Single Family Residential
15 114713 RK	A-10	Agriculture-10 Acre	Single Family Residential
15 117090 000 01 RK	R-5	Rural-5 Acre	Single Family Residential
16 117605 RK	R-9,600	Residential 9,600 sq. ft.	Single Family Residential

Accessory Dwelling Units

Index # - File Name: 1.0022 - Single Family Dwellings Data\_Snohomish County.pdf

16 117814 RK	R-9,600	Residential 9,600 sq. ft.	Single Family Residential
16 119420 RK	R-9,600	Residential 9,600 sq. ft.	Single Family Residential
16 119422 RK	R-9,600	Residential 9,600 sq. ft.	Single Family Residential
15 117663 RK	R-7,200(PRD)	Residential 7,200 sq. ft.	SFR-Basic
16 108805 RK	R-7,200(PRD)	Residential 7,200 sq. ft.	SFR-Basic
16 108806 RK	R-7,200(PRD)	Residential 7,200 sq. ft.	SFR-Basic
16 108807 RK	R-7,200(PRD)	Residential 7,200 sq. ft.	SFR-Basic
16 103671 RK	R-7,200(PRD)	Residential 7,200 sq. ft.	SFR-Basic
16 103672 RK	R-7,200(PRD)	Residential 7,200 sq. ft.	SFR-Basic
16 103067 RK	R-7,200(PRD)	Residential 7,200 sq. ft.	SFR-Basic
16 103068 RK	R-7,200(PRD)	Residential 7,200 sq. ft.	SFR-Basic
16 102560 RK	R-7,200(PRD)	Residential 7,200 sq. ft.	SFR-Basic
16 102561 RK	R-7,200(PRD)	Residential 7,200 sq. ft.	SFR-Basic
16 101419 RK	R-7,200(PRD)	Residential 7,200 sq. ft.	SFR-Basic
16 101420 RK	R-7,200(PRD)	Residential 7,200 sq. ft.	SFR-Basic
16 101421 RK	R-7,200(PRD)	Residential 7,200 sq. ft.	SFR-Basic
16 114832 RK	R-7,200	Residential 7,200 sq. ft.	Single Family Residential
16 117518 RK	R-7,200	Residential 7,200 sq. ft.	Single Family Residential
15 118539 RK	LDMR	Low Density Multiple Reside	Single Family Residential
16 105859 RK	R-5	Rural-5 Acre	SFR-Basic
16 117681 RK	R-5	Rural-5 Acre	SFR-Basic
16 103245 RK	R-5	Rural-5 Acre	SFR-Basic
16 108900 RK	R-5	Rural-5 Acre	SFR-Basic
16 114366 RK	R-5	Rural-5 Acre	SFR-Basic
16 107639 RK	R-5	Rural-5 Acre	SFR-Basic
16 110877 RK	R-5	Rural-5 Acre	SFR-Basic
16 110878 RK	R-5	Rural-5 Acre	SFR-Basic
16 110876 RK	R-5	Rural-5 Acre	SFR-Basic
16 118222 RK	R-9,600	Residential 9,600 sq. ft.	SFR-Basic
16 118641 RK	R-9,600	Residential 9,600 sq. ft.	SFR-Basic
15 119806 RK	MR	Multiple Residential	SFR-Basic
15 118694 RK	MR	Multiple Residential	SFR-Basic
15 118716 RK	MR	Multiple Residential	SFR-Basic
15 118695 RK	MR	Multiple Residential	SFR-Basic
15 118707 RK	MR	Multiple Residential	SFR-Basic
15 118717 RK	MR	Multiple Residential	SFR-Basic
15 118696 RK	MR	Multiple Residential	SFR-Basic
15 118697 RK	MR	Multiple Residential	SFR-Basic
15 118708 RK	MR	Multiple Residential	SFR-Basic
15 118718 RK	MR	Multiple Residential	SFR-Basic
15 118698 RK	MR	Multiple Residential	SFR-Basic
15 118710 RK	MR	Multiple Residential	SFR-Basic
15 118699 RK	MR	Multiple Residential	SFR-Basic
15 118700 RK	MR	Multiple Residential	SFR-Basic
15 118711 RK	MR	Multiple Residential	SFR-Basic
15 118701 RK	MR	Multiple Residential	SFR-Basic
15 118713 RK	MR	Multiple Residential	SFR-Basic

Accessory Dwelling Units

Index # - File Name: 1.0022 - Single Family Dwellings Data\_Snohomish County.pdf

15 118702 RK	MR	Multiple Residential	SFR-Basic
15 118703 RK	MR	Multiple Residential	SFR-Basic
15 118714 RK	MR	Multiple Residential	SFR-Basic
16 102163 RK	R-7,200	R-9,€ Residential 7,200 sq. ft.	Re: SFR-Basic
15 119901 RK	R-7,200	R-9,€ Residential 7,200 sq. ft.	Re: SFR-Basic
15 119902 RK	R-7,200	R-9,€ Residential 7,200 sq. ft.	Re: SFR-Basic
15 119903 RK	R-7,200	R-9,€ Residential 7,200 sq. ft.	Re: SFR-Basic
15 119904 RK	R-7,200	R-9,€ Residential 7,200 sq. ft.	Re: SFR-Basic
16 100906 RK	NB	PRD-9,60 Neighborhood Business	Re: SFR-Basic
16 109165 RK	NB	PRD-9,60 Neighborhood Business	Re: SFR-Basic
16 109166 RK	NB	PRD-9,60 Neighborhood Business	Re: SFR-Basic
16 109167 RK	NB	PRD-9,60 Neighborhood Business	Re: SFR-Basic
16 109168 RK	NB	PRD-9,60 Neighborhood Business	Re: SFR-Basic
16 109169 RK	NB	PRD-9,60 Neighborhood Business	Re: SFR-Basic
16 109170 RK	NB	PRD-9,60 Neighborhood Business	Re: SFR-Basic
16 100904 RK	NB	PRD-9,60 Neighborhood Business	Re: SFR-Basic
16 100905 RK	NB	PRD-9,60 Neighborhood Business	Re: SFR-Basic
16 109164 RK	NB	PRD-9,60 Neighborhood Business	Re: SFR-Basic
16 100907 RK	NB	PRD-9,60 Neighborhood Business	Re: SFR-Basic
16 100908 RK	NB	PRD-9,60 Neighborhood Business	Re: SFR-Basic
16 100909 RK	NB	PRD-9,60 Neighborhood Business	Re: SFR-Basic
16 100910 RK	NB	PRD-9,60 Neighborhood Business	Re: SFR-Basic
16 100911 RK	NB	PRD-9,60 Neighborhood Business	Re: SFR-Basic
16 109171 RK	NB	PRD-9,60 Neighborhood Business	Re: SFR-Basic
16 109172 RK	NB	PRD-9,60 Neighborhood Business	Re: SFR-Basic
16 109173 RK	NB	PRD-9,60 Neighborhood Business	Re: SFR-Basic
16 109174 RK	NB	PRD-9,60 Neighborhood Business	Re: SFR-Basic
16 109175 RK	NB	PRD-9,60 Neighborhood Business	Re: SFR-Basic
16 109176 RK	NB	PRD-9,60 Neighborhood Business	Re: SFR-Basic
16 109177 RK	NB	PRD-9,60 Neighborhood Business	Re: SFR-Basic
16 109178 RK	NB	PRD-9,60 Neighborhood Business	Re: SFR-Basic
16 109179 RK	NB	PRD-9,60 Neighborhood Business	Re: SFR-Basic
16 109180 RK	NB	PRD-9,60 Neighborhood Business	Re: SFR-Basic
16 109181 RK	NB	PRD-9,60 Neighborhood Business	Re: SFR-Basic
16 109182 RK	NB	PRD-9,60 Neighborhood Business	Re: SFR-Basic
16 102001 RK	NB	PRD-9,60 Neighborhood Business	Re: SFR-Basic
16 102002 RK	NB	PRD-9,60 Neighborhood Business	Re: SFR-Basic
16 106408 RK	R-9,600	Residential 9,600 sq. ft.	SFR-Basic
16 106409 RK	R-9,600	Residential 9,600 sq. ft.	SFR-Basic
16 106410 RK	R-9,600	Residential 9,600 sq. ft.	SFR-Basic
16 106411 RK	R-9,600	Residential 9,600 sq. ft.	SFR-Basic
16 106412 RK	R-9,600	Residential 9,600 sq. ft.	SFR-Basic
16 106413 RK	R-9,600	Residential 9,600 sq. ft.	SFR-Basic
16 106414 RK	R-9,600	Residential 9,600 sq. ft.	SFR-Basic
16 106415 RK	R-9,600	Residential 9,600 sq. ft.	SFR-Basic
16 106416 RK	R-9,600	Residential 9,600 sq. ft.	SFR-Basic
16 106417 RK	R-9,600	Residential 9,600 sq. ft.	SFR-Basic



Accessory Dwelling Units

Index # - File Name: 1.0022 - Single Family Dwellings Data\_Snohomish County.pdf

16 106085 RK	R-9,600	Residential 9,600 sq. ft.	SFR-Basic
16 106086 RK	R-9,600	Residential 9,600 sq. ft.	SFR-Basic
16 106087 RK	R-9,600	Residential 9,600 sq. ft.	SFR-Basic
16 106088 RK	R-9,600	Residential 9,600 sq. ft.	SFR-Basic
16 106089 RK	R-9,600	Residential 9,600 sq. ft.	SFR-Basic
16 106418 RK	R-9,600	Residential 9,600 sq. ft.	SFR-Basic
16 106090 RK	R-9,600	Residential 9,600 sq. ft.	SFR-Basic
15 117348 MH	R-5	Rural-5 Acre	Double Wide
16 103523 RK	R-9,600	Residential 9,600 sq. ft.	Single Family Residential
16 103525 RK	R-9,600	Residential 9,600 sq. ft.	Single Family Residential
15 119378 RK	R-5	Rural-5 Acre	Single Family Residential
16 117004 RK	R-9,600	Residential 9,600 sq. ft.	Single Family Residential
16 120464 RK	R-9,600	Residential 9,600 sq. ft.	Single Family Residential
16 108716 RK	R-9,600	Residential 9,600 sq. ft.	Single Family Residential
16 113666 RK	R-9,600	Residential 9,600 sq. ft.	Single Family Residential
16 117967 RK	R-9,600	Residential 9,600 sq. ft.	Single Family Residential
16 112122 RK	R-9,600	Residential 9,600 sq. ft.	Single Family Residential
16 112120 RK	R-9,600	Residential 9,600 sq. ft.	Single Family Residential
16 117002 RK	R-9,600	Residential 9,600 sq. ft.	Single Family Residential
16 101790 RK	R-5	Rural-5 Acre	SFR-Basic
16 101788 RK	R-5	Rural-5 Acre	SFR-Basic
16 103337 RK	R-5	Rural-5 Acre	SFR-Basic
16 101791 RK	R-5	Rural-5 Acre	SFR-Basic
16 101796 RK	R-5	Rural-5 Acre	SFR-Basic
16 103338 RK	R-5	Rural-5 Acre	SFR-Basic
16 101792 RK	R-5	Rural-5 Acre	SFR-Basic
16 101797 RK	R-5	Rural-5 Acre	SFR-Basic
16 101789 RK	R-5	Rural-5 Acre	SFR-Basic
16 103339 RK	R-5	Rural-5 Acre	SFR-Basic
16 101794 RK	R-5	Rural-5 Acre	SFR-Basic
16 100783 RK	R-5	Rural-5 Acre	SFR-Basic
16 100784 RK	R-5	Rural-5 Acre	SFR-Basic
16 100780 RK	R-5	Rural-5 Acre	SFR-Basic
16 100966 RK	R-5	Rural-5 Acre	SFR-Basic
16 100976 RK	R-5	Rural-5 Acre	SFR-Basic
16 100962 RK	R-5	Rural-5 Acre	SFR-Basic
16 100973 RK	R-5	Rural-5 Acre	SFR-Basic
16 108736 RK	R-5	Rural-5 Acre	SFR-Basic
16 100785 RK	R-5	Rural-5 Acre	SFR-Basic
16 100968 RK	R-5	Rural-5 Acre	SFR-Basic
16 100964 RK	R-5	Rural-5 Acre	SFR-Basic
16 100960 RK	R-5	Rural-5 Acre	SFR-Basic
16 100967 RK	R-5	Rural-5 Acre	SFR-Basic
16 100974 RK	R-5	Rural-5 Acre	SFR-Basic
16 100965 RK	R-5	Rural-5 Acre	SFR-Basic
16 100972 RK	R-5	Rural-5 Acre	SFR-Basic
16 100782 RK	R-5	Rural-5 Acre	SFR-Basic

Accessory Dwelling Units

Index # - File Name: 1.0022 - Single Family Dwellings Data\_Snohomish County.pdf

16 100961 RK	R-5	Rural-5 Acre	SFR-Basic
16 108483 RK	R-5	Rural-5 Acre	SFR-Basic
16 100786 RK	R-5	Rural-5 Acre	SFR-Basic
16 100781 RK	R-5	Rural-5 Acre	SFR-Basic
16 100963 RK	R-5	Rural-5 Acre	SFR-Basic
16 109725 RK	R-5	Rural-5 Acre	SFR-Basic
15 117671 RK	R-7,200(PRD)	Residential 7,200 sq. ft.	SFR-Basic
16 100506 RK	R-7,200(PRD)	Residential 7,200 sq. ft.	SFR-Basic
16 100507 RK	R-7,200(PRD)	Residential 7,200 sq. ft.	SFR-Basic
16 100508 RK	R-7,200(PRD)	Residential 7,200 sq. ft.	SFR-Basic
16 101418 RK	R-7,200(PRD)	Residential 7,200 sq. ft.	SFR-Basic
16 100509 RK	R-7,200(PRD)	Residential 7,200 sq. ft.	SFR-Basic
16 100510 RK	R-7,200(PRD)	Residential 7,200 sq. ft.	SFR-Basic
16 100511 RK	R-7,200(PRD)	Residential 7,200 sq. ft.	SFR-Basic
16 100512 RK	R-7,200(PRD)	Residential 7,200 sq. ft.	SFR-Basic
16 108808 RK	R-7,200(PRD)	Residential 7,200 sq. ft.	SFR-Basic
16 108802 RK	R-7,200(PRD)	Residential 7,200 sq. ft.	SFR-Basic
16 103670 RK	R-7,200(PRD)	Residential 7,200 sq. ft.	SFR-Basic
16 103065 RK	R-7,200(PRD)	Residential 7,200 sq. ft.	SFR-Basic
16 102558 RK	R-7,200(PRD)	Residential 7,200 sq. ft.	SFR-Basic
16 102559 RK	R-7,200(PRD)	Residential 7,200 sq. ft.	SFR-Basic
16 103066 RK	R-7,200(PRD)	Residential 7,200 sq. ft.	SFR-Basic
16 103701 RK	R-7,200(PRD)	Residential 7,200 sq. ft.	SFR-Basic
16 108803 RK	R-7,200(PRD)	Residential 7,200 sq. ft.	SFR-Basic
16 108804 RK	R-7,200(PRD)	Residential 7,200 sq. ft.	SFR-Basic
16 100505 RK	R-7,200(PRD)	Residential 7,200 sq. ft.	SFR-Basic
15 117670 RK	R-7,200(PRD)	Residential 7,200 sq. ft.	SFR-Basic
16 100802 RK	R-7,200(PRD)	Residential 7,200 sq. ft.	SFR-Basic
15 119042 RK	R-7,200(PRD)	Residential 7,200 sq. ft.	SFR-Basic
15 117662 RK	R-7,200(PRD)	Residential 7,200 sq. ft.	SFR-Basic
15 116294 RK	R-5	Rural-5 Acre	Single Family Residential
15 116305 RK	R-5	Rural-5 Acre	Accessory Apt Detached
16 111108 RK	R-5	Rural-5 Acre	SFR-Basic
16 111120 RK	R-5	Rural-5 Acre	SFR-Basic
16 111123 RK	R-5	Rural-5 Acre	SFR-Basic
16 111128 RK	R-5	Rural-5 Acre	SFR-Basic
16 111110 RK	R-5	Rural-5 Acre	SFR-Basic
16 111130 RK	R-5	Rural-5 Acre	SFR-Basic
16 111132 RK	R-5	Rural-5 Acre	SFR-Basic
16 111116 RK	R-5	Rural-5 Acre	SFR-Basic
16 111109 RK	R-5	Rural-5 Acre	SFR-Basic
16 111133 RK	R-5	Rural-5 Acre	SFR-Basic
16 111119 RK	R-5	Rural-5 Acre	SFR-Basic
16 111136 RK	R-5	Rural-5 Acre	SFR-Basic
16 111114 RK	R-5	Rural-5 Acre	SFR-Basic
15 117147 RK	R-5	Rural-5 Acre	Single Family Residential
16 100707 RK	LDMR	Low Density Multiple Reside Duplex	

Accessory Dwelling Units

Index # - File Name: 1.0022 - Single Family Dwellings Data\_Snohomish County.pdf

16 106109 RK	R-7,200	Residential 7,200 sq. ft.	SFR-Basic
16 106110 RK	R-7,200	Residential 7,200 sq. ft.	SFR-Basic
16 106111 RK	R-7,200	Residential 7,200 sq. ft.	SFR-Basic
16 106112 RK	R-7,200	Residential 7,200 sq. ft.	SFR-Basic
16 106113 RK	R-7,200	Residential 7,200 sq. ft.	SFR-Basic
15 115765 RK	R-5	Rural-5 Acre	Single Family Residential
16 102364 RK	R-7,200	Residential 7,200 sq. ft.	SFR-Basic
15 113952 RK	R-5	Rural-5 Acre	Single Family Residential
16 102567 RK	LDMR : R-7,20 Low Density Multiple Reside SFR-Basic		
16 103258 RK	LDMR : R-7,20 Low Density Multiple Reside SFR-Basic		
16 102568 RK	LDMR : R-7,20 Low Density Multiple Reside SFR-Basic		
16 103259 RK	LDMR : R-7,20 Low Density Multiple Reside SFR-Basic		
16 102569 RK	LDMR : R-7,20 Low Density Multiple Reside SFR-Basic		
16 103114 RK	LDMR : R-7,20 Low Density Multiple Reside Duplex-Basic		
16 106296 RK	LDMR : R-7,20 Low Density Multiple Reside Duplex-Basic		
16 107546 RK	LDMR : R-7,20 Low Density Multiple Reside SFR-Basic		
16 107547 RK	LDMR : R-7,20 Low Density Multiple Reside SFR-Basic		
15 118835 RK	R-8,400	Residential 8,400 sq. ft.	SFR-Basic
15 118836 RK	R-8,400	Residential 8,400 sq. ft.	SFR-Basic
15 118837 RK	R-8,400	Residential 8,400 sq. ft.	SFR-Basic
15 118838 RK	R-8,400	Residential 8,400 sq. ft.	SFR-Basic
15 118839 RK	R-8,400	Residential 8,400 sq. ft.	SFR-Basic
15 118840 RK	R-8,400	Residential 8,400 sq. ft.	SFR-Basic
16 105103 MH	R-5	Rural-5 Acre	Double Wide
16 109856 RK	R-7,200(PRD)	Residential 7,200 sq. ft.	SFR-Basic
16 102056 RK	R-7,200(PRD)	Residential 7,200 sq. ft.	SFR-Basic
16 102057 RK	R-7,200(PRD)	Residential 7,200 sq. ft.	SFR-Basic
16 102058 RK	R-7,200(PRD)	Residential 7,200 sq. ft.	SFR-Basic
16 102563 RK	R-7,200(PRD)	Residential 7,200 sq. ft.	SFR-Basic
16 102564 RK	R-7,200(PRD)	Residential 7,200 sq. ft.	SFR-Basic
15 119006 RK	R-7,200(PRD)	Residential 7,200 sq. ft.	SFR-Basic
16 100363 RK	R-7,200(PRD)	Residential 7,200 sq. ft.	SFR-Basic
16 100364 RK	R-7,200(PRD)	Residential 7,200 sq. ft.	SFR-Basic
16 100365 RK	R-7,200(PRD)	Residential 7,200 sq. ft.	SFR-Basic
16 100366 RK	R-7,200(PRD)	Residential 7,200 sq. ft.	SFR-Basic
16 103093 RK	R-7,200(PRD)	Residential 7,200 sq. ft.	SFR-Basic
16 103094 RK	R-7,200(PRD)	Residential 7,200 sq. ft.	SFR-Basic
16 103095 RK	R-7,200(PRD)	Residential 7,200 sq. ft.	SFR-Basic
16 100361 RK	R-7,200(PRD)	Residential 7,200 sq. ft.	SFR-Basic
16 100362 RK	R-7,200(PRD)	Residential 7,200 sq. ft.	SFR-Basic
15 119493 RK	NB	Neighborhood Business	Single Family Residential
16 105585 RK	NB	Neighborhood Business	Single Family Residential
15 119494 RK	NB	Neighborhood Business	Single Family Residential
16 105575 RK	NB	Neighborhood Business	Single Family Residential
16 103072 RK	NB	Neighborhood Business	Single Family Residential
16 100123 RK	NB	Neighborhood Business	Single Family Residential
16 100114 RK	NB	Neighborhood Business	Single Family Residential

Accessory Dwelling Units

Index # - File Name: 1.0022 - Single Family Dwellings Data\_Snohomish County.pdf

15 110295 RK	MR	Multiple Residential	Single Family Residential
15 110299 RK	MR	Multiple Residential	Single Family Residential
15 110300 RK	MR	Multiple Residential	Single Family Residential
16 101005 RK	R-5	Rural-5 Acre	SFR-Basic
16 101007 RK	R-5	Rural-5 Acre	SFR-Basic
16 110269 RK	R-5	Rural-5 Acre	SFR-Basic
16 108753 RK	R-5	Rural-5 Acre	SFR-Basic
16 108389 RK	R-5	Rural-5 Acre	SFR-Basic
16 108976 RK	R-5	Rural-5 Acre	SFR-Basic
16 108975 RK	R-5	Rural-5 Acre	SFR-Basic
16 108391 RK	R-5	Rural-5 Acre	SFR-Basic
16 109295 RK	R-5	Rural-5 Acre	SFR-Basic
16 108754 RK	R-5	Rural-5 Acre	SFR-Basic
16 108977 RK	R-5	Rural-5 Acre	SFR-Basic
16 114379 RK	R-5	Rural-5 Acre	Single Family Residential
16 114324 RK	R-5	Rural-5 Acre	Single Family Residential
16 110325 RK	R-5	Rural-5 Acre	Single Family Residential
16 102664 RK	R-5	Rural-5 Acre	Single Family Residential
16 102665 RK	R-5	Rural-5 Acre	Single Family Residential
16 102666 RK	R-5	Rural-5 Acre	Single Family Residential
16 102672 RK	R-5	Rural-5 Acre	Single Family Residential
16 108030 RK	R-7,200	Residential 7,200 sq. ft.	Single Family Residential
16 103220 RK	R-7,200	Residential 7,200 sq. ft.	Single Family Residential
16 108033 RK	R-7,200	Residential 7,200 sq. ft.	Single Family Residential
16 120281 RK	R-7,200	Residential 7,200 sq. ft.	Single Family Residential
16 108031 RK	R-7,200	Residential 7,200 sq. ft.	Single Family Residential
16 102648 RK	R-7,200	Residential 7,200 sq. ft.	Single Family Residential
16 104238 RK	R-7,200	Residential 7,200 sq. ft.	Single Family Residential
16 102649 RK	R-7,200	Residential 7,200 sq. ft.	Single Family Residential
16 103372 RK	R-7,200	Residential 7,200 sq. ft.	Single Family Residential
16 103374 RK	R-7,200	Residential 7,200 sq. ft.	Single Family Residential
15 113564 RK	R-5	Rural-5 Acre	Single Family Residential
16 106746 RK	R-7,200	Residential 7,200 sq. ft.	Single Family Residential
16 108789 RK	R-5	Rural-5 Acre	SFR-Basic
16 103984 RK	R-5	Rural-5 Acre	SFR-Basic
16 103980 RK	R-5	Rural-5 Acre	SFR-Basic
16 103986 RK	R-5	Rural-5 Acre	SFR-Basic
15 112809 RK	R-7,200	Residential 7,200 sq. ft.	SFR-Basic
15 119044 RK	R-7,200	Residential 7,200 sq. ft.	SFR-Basic
16 103431 RK	R-7,200(PRD)	Residential 7,200 sq. ft.	SFR-Basic
16 108624 RK	RRT-10	Rural Resource Transition-10	Single Family Residential
16 103060 RK	R-7,200(PRD)	Residential 7,200 sq. ft.	SFR-Basic
16 106591 RK	R-7,200	Residential 7,200 sq. ft.	Single Family Residential
16 109882 RK	R-7,200	Residential 7,200 sq. ft.	Single Family Residential
16 100385 RK	R-7,200	Residential 7,200 sq. ft.	Single Family Residential
16 114224 RK	R-7,200	Residential 7,200 sq. ft.	Single Family Residential
16 102489 RK	R-7,200	Residential 7,200 sq. ft.	Single Family Residential

Accessory Dwelling Units

Index # - File Name: 1.0022 - Single Family Dwellings Data\_Snohomish County.pdf

16 102488 RK	R-7,200	Residential 7,200 sq. ft.	Single Family Residential
16 110695 RK	R-7,200	Residential 7,200 sq. ft.	Single Family Residential
16 114425 RK	R-7,200	Residential 7,200 sq. ft.	Single Family Residential
16 107733 RK	R-7,200	Residential 7,200 sq. ft.	Single Family Residential
16 107730 RK	R-7,200	Residential 7,200 sq. ft.	Single Family Residential
16 102840 RK	R-7,200	Residential 7,200 sq. ft.	Single Family Residential
16 102841 RK	R-7,200	Residential 7,200 sq. ft.	Single Family Residential
16 102842 RK	R-7,200	Residential 7,200 sq. ft.	Single Family Residential
16 100313 RK	R-7,200	Residential 7,200 sq. ft.	Single Family Residential
16 101148 RK	R-7,200	Residential 7,200 sq. ft.	Single Family Residential
16 104077 RK	R-7,200	Residential 7,200 sq. ft.	Single Family Residential
16 107744 RK	R-7,200	Residential 7,200 sq. ft.	Single Family Residential
16 107742 RK	R-7,200	Residential 7,200 sq. ft.	Single Family Residential
16 107877 RK	R-7,200	Residential 7,200 sq. ft.	Single Family Residential
16 107874 RK	R-7,200	Residential 7,200 sq. ft.	Single Family Residential
16 104079 RK	R-7,200	Residential 7,200 sq. ft.	Single Family Residential
16 104237 RK	R-7,200	Residential 7,200 sq. ft.	Single Family Residential
16 104081 RK	R-7,200	Residential 7,200 sq. ft.	Single Family Residential
15 118947 RK	R-7,200	Residential 7,200 sq. ft.	SFR-Basic
16 114296 RK	R-7,200	Residential 7,200 sq. ft.	Single Family Residential
16 114297 RK	R-7,200	Residential 7,200 sq. ft.	Single Family Residential
16 120277 RK	R-7,200	Residential 7,200 sq. ft.	Single Family Residential
15 105718 RK	R-7,200(PRD)	Residential 7,200 sq. ft.	SFR-Basic
16 102117 RK	R-7,200(PRD)	Residential 7,200 sq. ft.	SFR-Basic
16 102118 RK	R-7,200(PRD)	Residential 7,200 sq. ft.	SFR-Basic
16 102119 RK	R-7,200(PRD)	Residential 7,200 sq. ft.	SFR-Basic
16 102120 RK	R-7,200(PRD)	Residential 7,200 sq. ft.	SFR-Basic
16 102121 RK	R-7,200(PRD)	Residential 7,200 sq. ft.	SFR-Basic
16 102122 RK	R-7,200(PRD)	Residential 7,200 sq. ft.	SFR-Basic
16 102116 RK	R-7,200(PRD)	Residential 7,200 sq. ft.	SFR-Basic
15 118639 RK	R-7,200(PRD)	Residential 7,200 sq. ft.	SFR-Basic
15 118640 RK	R-7,200(PRD)	Residential 7,200 sq. ft.	SFR-Basic
15 118641 RK	R-7,200(PRD)	Residential 7,200 sq. ft.	SFR-Basic
15 118642 RK	R-7,200(PRD)	Residential 7,200 sq. ft.	SFR-Basic
15 106367 RK	R-5	Rural-5 Acre	Single Family Residential
16 104076 RK	R-7,200	Residential 7,200 sq. ft.	Single Family Residential
16 103217 RK	R-7,200	Residential 7,200 sq. ft.	Single Family Residential
16 103376 RK	R-7,200	Residential 7,200 sq. ft.	Single Family Residential
16 107737 RK	R-7,200	Residential 7,200 sq. ft.	Single Family Residential
16 114422 RK	R-7,200	Residential 7,200 sq. ft.	Single Family Residential
16 110703 RK	R-7,200	Residential 7,200 sq. ft.	Single Family Residential
16 114219 RK	R-7,200	Residential 7,200 sq. ft.	Single Family Residential
16 110698 RK	R-7,200	Residential 7,200 sq. ft.	Single Family Residential
16 114221 RK	R-7,200	Residential 7,200 sq. ft.	Single Family Residential
16 109884 RK	R-7,200	Residential 7,200 sq. ft.	Single Family Residential
16 114222 RK	R-7,200	Residential 7,200 sq. ft.	Single Family Residential
15 108522 000 01 RK	R-5	Rural-5 Acre	Single Family Residential

Accessory Dwelling Units

Index # - File Name: 1.0022 - Single Family Dwellings Data\_Snohomish County.pdf

15 118549 RK	R-9,600	Residential 9,600 sq. ft.	SFR-Basic
16 100301 RK	R-9,600	Residential 9,600 sq. ft.	SFR-Basic
15 118550 RK	R-9,600	Residential 9,600 sq. ft.	SFR-Basic
15 118551 RK	R-9,600	Residential 9,600 sq. ft.	SFR-Basic
15 119271 RK	R-9,600	Residential 9,600 sq. ft.	Single Family Residential
16 100302 RK	R-9,600	Residential 9,600 sq. ft.	SFR-Basic
16 100303 RK	R-9,600	Residential 9,600 sq. ft.	SFR-Basic
16 100304 RK	R-9,600	Residential 9,600 sq. ft.	SFR-Basic
16 100305 RK	R-9,600	Residential 9,600 sq. ft.	SFR-Basic
15 118552 RK	R-9,600	Residential 9,600 sq. ft.	SFR-Basic
15 119046 RK	R-7,200	Residential 7,200 sq. ft.	SFR-Basic
15 119200 RK	R-7,200	Residential 7,200 sq. ft.	SFR-Basic
16 101036 RK	R-7,200	Residential 7,200 sq. ft.	SFR-Basic
16 101039 RK	R-7,200	Residential 7,200 sq. ft.	SFR-Basic
15 119202 RK	R-7,200	Residential 7,200 sq. ft.	SFR-Basic
16 103370 RK	R-7,200	Residential 7,200 sq. ft.	SFR-Basic
16 103052 RK	R-7,200	Residential 7,200 sq. ft.	SFR-Basic
16 103053 RK	R-7,200	Residential 7,200 sq. ft.	SFR-Basic
16 102094 RK	R-7,200	Residential 7,200 sq. ft.	SFR-Basic
16 106097 RK	R-7,200	Residential 7,200 sq. ft.	SFR-Basic
16 106103 RK	R-7,200	Residential 7,200 sq. ft.	SFR-Basic
16 106094 RK	R-7,200	Residential 7,200 sq. ft.	SFR-Basic
16 106100 RK	R-7,200	Residential 7,200 sq. ft.	SFR-Basic
16 106101 RK	R-7,200	Residential 7,200 sq. ft.	SFR-Basic
16 103050 RK	R-7,200	Residential 7,200 sq. ft.	SFR-Basic
16 102093 RK	R-7,200	Residential 7,200 sq. ft.	SFR-Basic
16 102092 RK	R-7,200	Residential 7,200 sq. ft.	SFR-Basic
15 118664 RK	R-7,200	Residential 7,200 sq. ft.	SFR-Basic
15 117558 RK	R-7,200	Residential 7,200 sq. ft.	SFR-Basic
15 117559 RK	R-7,200	Residential 7,200 sq. ft.	SFR-Basic
15 117560 RK	R-7,200	Residential 7,200 sq. ft.	SFR-Basic
15 117562 RK	R-7,200	Residential 7,200 sq. ft.	SFR-Basic
16 106102 RK	R-7,200	Residential 7,200 sq. ft.	SFR-Basic
16 106104 RK	R-7,200	Residential 7,200 sq. ft.	SFR-Basic
16 101038 RK	R-7,200	Residential 7,200 sq. ft.	SFR-Basic
16 102676 RK	A-10	Agriculture-10 Acre	SFR-Basic
16 103597 RK	R-5	Rural-5 Acre	SFR-Basic
16 102482 RK	R-5	Rural-5 Acre	SFR-Basic
16 106678 RK	R-5	Rural-5 Acre	SFR-Basic
15 119684 RK	R-5	Rural-5 Acre	SFR-Basic
15 119683 RK	R-5	Rural-5 Acre	SFR-Basic
16 106690 RK	R-5	Rural-5 Acre	SFR-Basic
16 106680 RK	R-5	Rural-5 Acre	SFR-Basic
16 111097 RK	R-5	Rural-5 Acre	SFR-Basic
16 111098 RK	R-5	Rural-5 Acre	SFR-Basic
16 106692 RK	R-5	Rural-5 Acre	SFR-Basic
16 106683 RK	R-5	Rural-5 Acre	SFR-Basic

Accessory Dwelling Units

Index # - File Name: 1.0022 - Single Family Dwellings Data\_Snohomish County.pdf

16 111099 RK	R-5	Rural-5 Acre	SFR-Basic
16 111100 RK	R-5	Rural-5 Acre	SFR-Basic
16 106303 RK	R-5	Rural-5 Acre	SFR-Basic
16 111101 RK	R-5	Rural-5 Acre	SFR-Basic
16 111102 RK	R-5	Rural-5 Acre	SFR-Basic
16 110827 RK	R-5	Rural-5 Acre	SFR-Basic
16 106685 RK	R-5	Rural-5 Acre	SFR-Basic
16 105681 RK	R-5	Rural-5 Acre	SFR-Basic
16 103598 RK	R-5	Rural-5 Acre	SFR-Basic
16 106687 RK	R-5	Rural-5 Acre	SFR-Basic
16 106688 RK	R-5	Rural-5 Acre	SFR-Basic
16 111104 RK	R-5	Rural-5 Acre	SFR-Basic
16 111105 RK	R-5	Rural-5 Acre	SFR-Basic
16 111106 RK	R-5	Rural-5 Acre	SFR-Basic
16 111107 RK	R-5	Rural-5 Acre	SFR-Basic
16 110855 RK	R-7,200	Residential 7,200 sq. ft.	Single Family Residential
15 118992 000 01 RK	R-7,200	Residential 7,200 sq. ft.	Single Family Residential
15 118996 000 01 RK	R-7,200	Residential 7,200 sq. ft.	Single Family Residential
16 113500 RK	R-7,200	Residential 7,200 sq. ft.	Single Family Residential
15 110185 RK	R-5	Rural-5 Acre	Single Family Residential
15 118286 RK	R-9,600	Residential 9,600 sq. ft.	SFR-Basic
16 101857 RK	LDMR	Low Density Multiple Reside	SFR-Basic
16 101835 RK	R-5	Rural-5 Acre	Single Family Residential
16 101831 RK	R-5	Rural-5 Acre	Single Family Residential
16 102114 RK	R-9,600	Residential 9,600 sq. ft.	SFR-Basic
15 119372 RK	R-9,600	Residential 9,600 sq. ft.	SFR-Basic
15 119373 RK	R-9,600	Residential 9,600 sq. ft.	SFR-Basic
16 101337 RK	R-9,600	Residential 9,600 sq. ft.	SFR-Basic
16 101338 RK	R-9,600	Residential 9,600 sq. ft.	SFR-Basic
16 101339 RK	R-9,600	Residential 9,600 sq. ft.	SFR-Basic
16 107205 RK	R-9,600	Residential 9,600 sq. ft.	Single Family Residential
16 105851 RK	R-9,600	Residential 9,600 sq. ft.	Single Family Residential
16 105857 RK	R-9,600	Residential 9,600 sq. ft.	Single Family Residential
16 107209 RK	R-9,600	Residential 9,600 sq. ft.	Single Family Residential
15 119374 RK	R-9,600	Residential 9,600 sq. ft.	SFR-Basic
15 118547 RK	R-9,600	Residential 9,600 sq. ft.	SFR-Basic
16 100299 RK	R-9,600	Residential 9,600 sq. ft.	SFR-Basic
16 100300 RK	R-9,600	Residential 9,600 sq. ft.	SFR-Basic
15 118548 RK	R-9,600	Residential 9,600 sq. ft.	SFR-Basic
15 119043 RK	R-7,200	Residential 7,200 sq. ft.	SFR-Basic
16 100636 RK	R-7,200(PRD)	Residential 7,200 sq. ft.	SFR-Basic
16 101413 RK	R-7,200(PRD)	Residential 7,200 sq. ft.	SFR-Basic
16 100637 RK	R-7,200(PRD)	Residential 7,200 sq. ft.	SFR-Basic
16 103059 RK	R-7,200(PRD)	Residential 7,200 sq. ft.	SFR-Basic
16 109853 RK	R-7,200(PRD)	Residential 7,200 sq. ft.	SFR-Basic
16 111165 RK	R-7,200(PRD)	Residential 7,200 sq. ft.	SFR-Basic
16 109854 RK	R-7,200(PRD)	Residential 7,200 sq. ft.	SFR-Basic

Accessory Dwelling Units

Index # - File Name: 1.0022 - Single Family Dwellings Data\_Snohomish County.pdf

16 109855 RK	R-7,200(PRD)	Residential 7,200 sq. ft.	SFR-Basic
16 103792 RK	R-7,200(PRD)	Residential 7,200 sq. ft.	SFR-Basic
16 103793 RK	R-7,200(PRD)	Residential 7,200 sq. ft.	SFR-Basic
16 109852 RK	R-7,200(PRD)	Residential 7,200 sq. ft.	SFR-Basic
16 107700 RK	R-7,200(PRD)	Residential 7,200 sq. ft.	SFR-Basic
16 107701 RK	R-7,200(PRD)	Residential 7,200 sq. ft.	SFR-Basic
15 119709 RK	R-7,200(PRD)	Residential 7,200 sq. ft.	SFR-Basic
16 109847 RK	R-7,200(PRD)	Residential 7,200 sq. ft.	SFR-Basic
16 103430 RK	R-7,200(PRD)	Residential 7,200 sq. ft.	SFR-Basic
16 110763 RK	R-7,200(PRD)	Residential 7,200 sq. ft.	SFR-Basic
16 107699 RK	R-7,200(PRD)	Residential 7,200 sq. ft.	SFR-Basic
16 109111 RK	R-7,200(PRD)	Residential 7,200 sq. ft.	SFR-Basic
16 103790 RK	R-7,200(PRD)	Residential 7,200 sq. ft.	SFR-Basic
16 109848 RK	R-7,200(PRD)	Residential 7,200 sq. ft.	SFR-Basic
16 109849 RK	R-7,200(PRD)	Residential 7,200 sq. ft.	SFR-Basic
16 110764 RK	R-7,200(PRD)	Residential 7,200 sq. ft.	SFR-Basic
16 109850 RK	R-7,200(PRD)	Residential 7,200 sq. ft.	SFR-Basic
16 109851 RK	R-7,200(PRD)	Residential 7,200 sq. ft.	SFR-Basic
16 103791 RK	R-7,200(PRD)	Residential 7,200 sq. ft.	SFR-Basic
16 100634 RK	R-7,200(PRD)	Residential 7,200 sq. ft.	SFR-Basic
16 100635 RK	R-7,200(PRD)	Residential 7,200 sq. ft.	SFR-Basic
15 119655 RK	R-7,200(PRD)	Residential 7,200 sq. ft.	SFR-Basic
15 117812 RK	R-9,600	Residential 9,600 sq. ft.	Single Family Residential
15 119274 RK	R-7,200	Residential 7,200 sq. ft.	SFR-Basic
15 119276 RK	R-7,200	Residential 7,200 sq. ft.	SFR-Basic
15 119278 RK	R-7,200	Residential 7,200 sq. ft.	SFR-Basic
16 105267 RK	R-5	Rural-5 Acre	SFR-Basic
16 109800 RK	R-5	Rural-5 Acre	Single Family Residential
16 108979 RK	R-5	Rural-5 Acre	SFR-Basic
16 117287 RK	R-5	Rural-5 Acre	SFR-Basic
16 100670 RK	R-5	Rural-5 Acre	SFR-Basic
16 102083 RK	R-5	Rural-5 Acre	SFR-Basic
16 106754 RK	R-5	Rural-5 Acre	SFR-Basic
16 108384 RK	R-5	Rural-5 Acre	SFR-Basic
16 105269 RK	R-5	Rural-5 Acre	SFR-Basic
15 118303 RK	R-5	Rural-5 Acre	Single Family Residential
16 108386 RK	R-5	Rural-5 Acre	SFR-Basic
16 105268 RK	R-5	Rural-5 Acre	SFR-Basic
16 105266 RK	R-5	Rural-5 Acre	SFR-Basic
16 102086 RK	R-5	Rural-5 Acre	SFR-Basic
16 102084 RK	R-5	Rural-5 Acre	SFR-Basic
16 111969 000 01 RK	A-10	Agriculture-10 Acre	Single Family Residential
16 100079 RK	R-7,200	Residential 7,200 sq. ft.	SFR-Basic
16 100544 RK	R-7,200	Residential 7,200 sq. ft.	SFR-Basic
16 117846 RK	R-5	Rural-5 Acre	Single Family Residential
16 102165 RK	R-7,200	Residential 7,200 sq. ft.	SFR-Basic
16 105117 RK	R-7,200	Residential 7,200 sq. ft.	SFR-Basic



Accessory Dwelling Units

Index # - File Name: 1.0022 - Single Family Dwellings Data\_Snohomish County.pdf

16 100545 RK	R-7,200	Residential 7,200 sq. ft.	SFR-Basic
16 109319 RK	R-5	Rural-5 Acre	Single Family Residential
16 110183 RK	R-5	Rural-5 Acre	Single Family Residential
16 108515 RK	R-5	Rural-5 Acre	Single Family Residential
16 107331 RK	R-5	Rural-5 Acre	Single Family Residential
16 107334 RK	R-5	Rural-5 Acre	Single Family Residential
16 105622 RK	R-5	Rural-5 Acre	Single Family Residential
16 105624 RK	R-5	Rural-5 Acre	Single Family Residential
16 105620 RK	R-5	Rural-5 Acre	Single Family Residential
15 118636 RK	R-5	Rural-5 Acre	Single Family Residential
15 118624 RK	R-5	Rural-5 Acre	Single Family Residential
16 103681 RK	R-5	Rural-5 Acre	Single Family Residential
16 103682 RK	R-5	Rural-5 Acre	Single Family Residential
16 107337 RK	R-5	Rural-5 Acre	Single Family Residential
16 103310 RK	R-5	Rural-5 Acre	Single Family Residential
16 103309 RK	R-5	Rural-5 Acre	Single Family Residential
16 105618 RK	R-5	Rural-5 Acre	Single Family Residential
16 117841 RK	R-5	Rural-5 Acre	Single Family Residential
16 100857 RK	R-5	Rural-5 Acre	Single Family Residential
16 110182 RK	R-5	Rural-5 Acre	Single Family Residential
16 104082 RK	R-5	Rural-5 Acre	Single Family Residential
15 119039 RK	R-7,200(PRD)	Residential 7,200 sq. ft.	SFR-Basic
15 119040 RK	R-7,200(PRD)	Residential 7,200 sq. ft.	SFR-Basic
16 100104 RK	R-7,200(PRD)	Residential 7,200 sq. ft.	SFR-Basic
16 100167 RK	R-7,200(PRD)	Residential 7,200 sq. ft.	SFR-Basic
16 100168 RK	R-7,200(PRD)	Residential 7,200 sq. ft.	SFR-Basic
16 100594 RK	R-7,200(PRD)	Residential 7,200 sq. ft.	SFR-Basic
16 100427 RK	R-7,200(PRD)	Residential 7,200 sq. ft.	SFR-Basic
16 100805 RK	R-7,200(PRD)	Residential 7,200 sq. ft.	SFR-Basic
16 101475 RK	R-7,200(PRD)	Residential 7,200 sq. ft.	SFR-Basic
16 101476 RK	R-7,200(PRD)	Residential 7,200 sq. ft.	SFR-Basic
16 102549 RK	R-7,200(PRD)	Residential 7,200 sq. ft.	SFR-Basic
16 102550 RK	R-7,200(PRD)	Residential 7,200 sq. ft.	SFR-Basic
16 102551 RK	R-7,200(PRD)	Residential 7,200 sq. ft.	SFR-Basic
16 102552 RK	R-7,200(PRD)	Residential 7,200 sq. ft.	SFR-Basic
16 102553 RK	R-7,200(PRD)	Residential 7,200 sq. ft.	SFR-Basic
16 102554 RK	R-7,200(PRD)	Residential 7,200 sq. ft.	SFR-Basic
16 102555 RK	R-7,200(PRD)	Residential 7,200 sq. ft.	SFR-Basic
16 101477 RK	R-7,200(PRD)	Residential 7,200 sq. ft.	SFR-Basic
16 101478 RK	R-7,200(PRD)	Residential 7,200 sq. ft.	SFR-Basic
16 101479 RK	R-7,200(PRD)	Residential 7,200 sq. ft.	SFR-Basic
16 100428 RK	R-7,200(PRD)	Residential 7,200 sq. ft.	SFR-Basic
16 100429 RK	R-7,200(PRD)	Residential 7,200 sq. ft.	SFR-Basic
16 106562 RK	R-7,200	Residential 7,200 sq. ft.	SFR-Basic
16 106563 RK	R-7,200	Residential 7,200 sq. ft.	SFR-Basic
16 106564 RK	R-7,200	Residential 7,200 sq. ft.	SFR-Basic
16 106565 RK	R-7,200	Residential 7,200 sq. ft.	SFR-Basic

Accessory Dwelling Units

Index # - File Name: 1.0022 - Single Family Dwellings Data\_Snohomish County.pdf

16 106566 RK	R-7,200	Residential 7,200 sq. ft.	SFR-Basic
16 106567 RK	R-7,200	Residential 7,200 sq. ft.	SFR-Basic
16 106568 RK	R-7,200	Residential 7,200 sq. ft.	SFR-Basic
16 106785 RK	R-7,200	Residential 7,200 sq. ft.	SFR-Basic
16 102782 RK	R-7,200	Residential 7,200 sq. ft.	SFR-Basic
16 101406 RK	R-7,200	Residential 7,200 sq. ft.	SFR-Basic
16 101407 RK	R-7,200	Residential 7,200 sq. ft.	SFR-Basic
16 101408 RK	R-7,200	Residential 7,200 sq. ft.	SFR-Basic
16 102964 RK	R-7,200	Residential 7,200 sq. ft.	SFR-Basic
16 100083 RK	R-7,200	Residential 7,200 sq. ft.	SFR-Basic
15 115257 RK	R-7,200	Residential 7,200 sq. ft.	SFR-Basic
16 106015 RK	R-7,200	Residential 7,200 sq. ft.	SFR-Basic
16 102783 RK	R-7,200	Residential 7,200 sq. ft.	SFR-Basic
16 102377 RK	R-7,200	Residential 7,200 sq. ft.	Single Family Residential
15 104252 RK	R-7,200	Residential 7,200 sq. ft.	SFR-Basic
16 117849 RK	R-5	Rural-5 Acre	Single Family Residential
15 119183 RK	R-7,200	Residential 7,200 sq. ft.	SFR-Basic
15 118356 RK	R-7,200	Residential 7,200 sq. ft.	SFR-Basic
15 111579 RK	R-7,200	Residential 7,200 sq. ft.	SFR-Basic
16 102784 RK	R-7,200	Residential 7,200 sq. ft.	SFR-Basic
16 120476 RK	R-9,600	Residential 9,600 sq. ft.	SFR-Basic
16 120477 RK	R-9,600	Residential 9,600 sq. ft.	SFR-Basic
16 119487 RK	R-9,600	Residential 9,600 sq. ft.	SFR-Basic
16 110873 RK	R-5	Rural-5 Acre	Single Family Residential
16 120478 RK	R-9,600	Residential 9,600 sq. ft.	SFR-Basic
16 118290 RK	R-5	Rural-5 Acre	SFR-Basic
16 114525 RK	R-9,600	Residential 9,600 sq. ft.	SFR-Basic
16 114526 RK	R-9,600	Residential 9,600 sq. ft.	SFR-Basic
16 114527 RK	R-9,600	Residential 9,600 sq. ft.	SFR-Basic
16 114528 RK	R-9,600	Residential 9,600 sq. ft.	SFR-Basic
16 114529 RK	R-9,600	Residential 9,600 sq. ft.	SFR-Basic
16 114530 RK	R-9,600	Residential 9,600 sq. ft.	SFR-Basic
16 114531 RK	R-9,600	Residential 9,600 sq. ft.	SFR-Basic
16 114532 RK	R-9,600	Residential 9,600 sq. ft.	SFR-Basic
16 114180 RK	LDMR : R-8,40	Low Density Multiple Reside	Single Family Residential
16 114176 RK	LDMR : R-8,40	Low Density Multiple Reside	Single Family Residential
16 114174 RK	LDMR : R-8,40	Low Density Multiple Reside	Single Family Residential
16 111634 RK	R-5	Rural-5 Acre	Single Family Residential
16 121775 RK	R-7,200	Residential 7,200 sq. ft.	SFR-Basic
16 121776 RK	R-7,200	Residential 7,200 sq. ft.	SFR-Basic
16 121777 RK	R-7,200	Residential 7,200 sq. ft.	SFR-Basic
16 121778 RK	R-7,200	Residential 7,200 sq. ft.	SFR-Basic
16 120544 RK	R-7,200	Residential 7,200 sq. ft.	SFR-Basic
16 120542 RK	R-7,200	Residential 7,200 sq. ft.	SFR-Basic
16 120543 RK	R-7,200	Residential 7,200 sq. ft.	SFR-Basic
16 120540 RK	R-7,200	Residential 7,200 sq. ft.	SFR-Basic
16 120541 RK	R-7,200	Residential 7,200 sq. ft.	SFR-Basic

Accessory Dwelling Units

Index # - File Name: 1.0022 - Single Family Dwellings Data\_Snohomish County.pdf

16 120538 RK	R-7,200	Residential 7,200 sq. ft.	SFR-Basic
16 121779 RK	R-7,200	Residential 7,200 sq. ft.	SFR-Basic
16 110592 RK	R-5	Rural-5 Acre	SFR-Basic
16 110595 RK	R-5	Rural-5 Acre	SFR-Basic
16 110598 RK	R-5	Rural-5 Acre	SFR-Basic
16 110600 RK	R-5	Rural-5 Acre	SFR-Basic
16 110599 RK	R-5	Rural-5 Acre	SFR-Basic
16 110601 RK	R-5	Rural-5 Acre	SFR-Basic
16 110594 RK	R-5	Rural-5 Acre	SFR-Basic
16 121782 RK	R-7,200	Residential 7,200 sq. ft.	SFR-Basic
16 121783 RK	R-7,200	Residential 7,200 sq. ft.	SFR-Basic
16 119485 RK	R-9,600	Residential 9,600 sq. ft.	SFR-Basic
16 119486 RK	R-9,600	Residential 9,600 sq. ft.	SFR-Basic
16 114835 RK	R-8,400	Residential 8,400 sq. ft.	Duplex
16 114149 RK	R-7,200 : R-9,600	Residential 7,200 sq. ft. : Residential 9,600 sq. ft.	Res: Single Family Residential
16 120484 RK	MR	Multiple Residential	SFR-Basic
16 120488 RK	MR	Multiple Residential	SFR-Basic
16 120489 RK	MR	Multiple Residential	SFR-Basic
16 120487 RK	MR	Multiple Residential	SFR-Basic
16 120483 RK	MR	Multiple Residential	SFR-Basic
16 106004 RK	R-7,200	Residential 7,200 sq. ft.	SFR-Basic
16 105613 RK	R-9,600	Residential 9,600 sq. ft.	Duplex-Basic
16 110528 RK	R-7,200(PRD)	Residential 7,200 sq. ft.	SFR-Basic
16 110529 RK	R-7,200(PRD)	Residential 7,200 sq. ft.	SFR-Basic
16 110530 RK	R-7,200(PRD)	Residential 7,200 sq. ft.	SFR-Basic
16 110054 RK	R-7,200(PRD)	Residential 7,200 sq. ft.	SFR-Basic
16 110055 RK	R-7,200(PRD)	Residential 7,200 sq. ft.	SFR-Basic
16 110056 RK	R-7,200(PRD)	Residential 7,200 sq. ft.	SFR-Basic
16 109476 RK	R-7,200(PRD)	Residential 7,200 sq. ft.	SFR-Basic
16 109477 RK	R-7,200(PRD)	Residential 7,200 sq. ft.	SFR-Basic
16 108434 RK	R-7,200(PRD)	Residential 7,200 sq. ft.	SFR-Basic
16 108435 RK	R-7,200(PRD)	Residential 7,200 sq. ft.	SFR-Basic
16 108436 RK	R-7,200(PRD)	Residential 7,200 sq. ft.	SFR-Basic
16 108437 RK	R-7,200(PRD)	Residential 7,200 sq. ft.	SFR-Basic
16 108438 RK	R-7,200(PRD)	Residential 7,200 sq. ft.	SFR-Basic
16 108439 RK	R-7,200(PRD)	Residential 7,200 sq. ft.	SFR-Basic
16 108440 RK	R-7,200(PRD)	Residential 7,200 sq. ft.	SFR-Basic
16 109478 RK	R-7,200(PRD)	Residential 7,200 sq. ft.	SFR-Basic
16 109479 RK	R-7,200(PRD)	Residential 7,200 sq. ft.	SFR-Basic
16 108441 RK	R-7,200(PRD)	Residential 7,200 sq. ft.	SFR-Basic
16 108442 RK	R-7,200(PRD)	Residential 7,200 sq. ft.	SFR-Basic
16 108744 RK	R-7,200(PRD)	Residential 7,200 sq. ft.	SFR-Basic
16 108745 RK	R-7,200(PRD)	Residential 7,200 sq. ft.	SFR-Basic
16 108746 RK	R-7,200(PRD)	Residential 7,200 sq. ft.	SFR-Basic
16 108443 RK	R-7,200(PRD)	Residential 7,200 sq. ft.	SFR-Basic
16 108444 RK	R-7,200(PRD)	Residential 7,200 sq. ft.	SFR-Basic
16 108445 RK	R-7,200(PRD)	Residential 7,200 sq. ft.	SFR-Basic

Accessory Dwelling Units

Index # - File Name: 1.0022 - Single Family Dwellings Data\_Snohomish County.pdf

16 108446 RK	R-7,200(PRD)	Residential 7,200 sq. ft.	SFR-Basic
16 108447 RK	R-7,200(PRD)	Residential 7,200 sq. ft.	SFR-Basic
16 108448 RK	R-7,200(PRD)	Residential 7,200 sq. ft.	SFR-Basic
16 108449 RK	R-7,200(PRD)	Residential 7,200 sq. ft.	SFR-Basic
16 108450 RK	R-7,200(PRD)	Residential 7,200 sq. ft.	SFR-Basic
16 108747 RK	R-7,200(PRD)	Residential 7,200 sq. ft.	SFR-Basic
16 108748 RK	R-7,200(PRD)	Residential 7,200 sq. ft.	SFR-Basic
16 110057 RK	R-7,200(PRD)	Residential 7,200 sq. ft.	SFR-Basic
16 110058 RK	R-7,200(PRD)	Residential 7,200 sq. ft.	SFR-Basic
16 110531 RK	R-7,200(PRD)	Residential 7,200 sq. ft.	SFR-Basic
16 110532 RK	R-7,200(PRD)	Residential 7,200 sq. ft.	SFR-Basic
16 109260 RK	F	Forestry	Single Family Residential
16 101354 RK	MR	Multiple Residential	SFR-Basic
16 101355 RK	MR	Multiple Residential	SFR-Basic
16 105216 RK	MR	Multiple Residential	SFR-Basic
16 107314 RK	MR	Multiple Residential	SFR-Basic
16 105214 RK	MR	Multiple Residential	SFR-Basic
16 107562 RK	MR	Multiple Residential	SFR-Basic
16 107561 RK	MR	Multiple Residential	SFR-Basic
16 107560 RK	MR	Multiple Residential	SFR-Basic
16 107559 RK	MR	Multiple Residential	SFR-Basic
16 107558 RK	MR	Multiple Residential	SFR-Basic
16 107557 RK	MR	Multiple Residential	SFR-Basic
16 107556 RK	MR	Multiple Residential	SFR-Basic
16 107555 RK	MR	Multiple Residential	SFR-Basic
16 107554 RK	MR	Multiple Residential	SFR-Basic
16 107553 RK	MR	Multiple Residential	SFR-Basic
16 107552 RK	MR	Multiple Residential	SFR-Basic
16 107313 RK	MR	Multiple Residential	SFR-Basic
16 107312 RK	MR	Multiple Residential	SFR-Basic
16 102060 RK	MR	Multiple Residential	SFR-Basic
16 105979 RK	MR	Multiple Residential	SFR-Basic
16 101353 RK	MR	Multiple Residential	SFR-Basic
16 101352 RK	MR	Multiple Residential	SFR-Basic
16 102059 RK	MR	Multiple Residential	SFR-Basic
16 101923 RK	R-5	Rural-5 Acre	Single Family Residential
16 109915 RK	LDMR : NB : R-	Low Density Multiple Reside	SFR-Basic
16 103399 RK	LDMR : NB : R-	Low Density Multiple Reside	SFR-Basic
16 109916 RK	LDMR : NB : R-	Low Density Multiple Reside	SFR-Basic
16 109917 RK	LDMR : NB : R-	Low Density Multiple Reside	SFR-Basic
16 109918 RK	LDMR : NB : R-	Low Density Multiple Reside	SFR-Basic
16 109919 RK	LDMR : NB : R-	Low Density Multiple Reside	SFR-Basic
16 109920 RK	LDMR : NB : R-	Low Density Multiple Reside	SFR-Basic
16 110543 RK	LDMR : NB : R-	Low Density Multiple Reside	SFR-Basic
16 110544 RK	LDMR : NB : R-	Low Density Multiple Reside	SFR-Basic
16 109921 RK	LDMR : NB : R-	Low Density Multiple Reside	SFR-Basic
16 109922 RK	LDMR : NB : R-	Low Density Multiple Reside	SFR-Basic

Accessory Dwelling Units

Index # - File Name: 1.0022 - Single Family Dwellings Data\_Snohomish County.pdf

16 109923 RK	LDMR : NB : R- Low Density Multiple Reside SFR-Basic		
16 109924 RK	LDMR : NB : R- Low Density Multiple Reside SFR-Basic		
16 109925 RK	LDMR : NB : R- Low Density Multiple Reside SFR-Basic		
16 110545 RK	LDMR : NB : R- Low Density Multiple Reside SFR-Basic		
16 110546 RK	LDMR : NB : R- Low Density Multiple Reside SFR-Basic		
16 110547 RK	LDMR : NB : R- Low Density Multiple Reside SFR-Basic		
16 110548 RK	LDMR : NB : R- Low Density Multiple Reside SFR-Basic		
16 110549 RK	LDMR : NB : R- Low Density Multiple Reside SFR-Basic		
16 110550 RK	LDMR : NB : R- Low Density Multiple Reside SFR-Basic		
16 110551 RK	LDMR : NB : R- Low Density Multiple Reside SFR-Basic		
16 110552 RK	LDMR : NB : R- Low Density Multiple Reside SFR-Basic		
16 110553 RK	LDMR : NB : R- Low Density Multiple Reside SFR-Basic		
16 110818 RK	R-7,200	Residential 7,200 sq. ft.	SFR-Basic
16 110819 RK	R-7,200	Residential 7,200 sq. ft.	SFR-Basic
16 110897 RK	R-7,200	Residential 7,200 sq. ft.	SFR-Basic
16 110898 RK	R-7,200	Residential 7,200 sq. ft.	SFR-Basic
16 110820 RK	R-7,200	Residential 7,200 sq. ft.	SFR-Basic
16 110821 RK	R-7,200	Residential 7,200 sq. ft.	SFR-Basic
16 110899 RK	R-7,200	Residential 7,200 sq. ft.	SFR-Basic
16 110900 RK	R-7,200	Residential 7,200 sq. ft.	SFR-Basic
16 118301 RK	R-7,200	Residential 7,200 sq. ft.	SFR-Basic
16 111166 RK	R-7,200	Residential 7,200 sq. ft.	SFR-Basic
16 111167 RK	R-7,200	Residential 7,200 sq. ft.	SFR-Basic
16 110667 RK	R-7,200	Residential 7,200 sq. ft.	SFR-Basic
16 110668 RK	R-7,200	Residential 7,200 sq. ft.	SFR-Basic
16 110627 RK	R-7,200	Residential 7,200 sq. ft.	SFR-Basic
16 110628 RK	R-7,200	Residential 7,200 sq. ft.	SFR-Basic
16 110629 RK	R-7,200	Residential 7,200 sq. ft.	SFR-Basic
16 110630 RK	R-7,200	Residential 7,200 sq. ft.	SFR-Basic
16 110669 RK	R-7,200	Residential 7,200 sq. ft.	SFR-Basic
16 110670 RK	R-7,200	Residential 7,200 sq. ft.	SFR-Basic
16 110901 RK	R-7,200	Residential 7,200 sq. ft.	SFR-Basic
16 110902 RK	R-7,200	Residential 7,200 sq. ft.	SFR-Basic
16 111168 RK	R-7,200	Residential 7,200 sq. ft.	SFR-Basic
16 110903 RK	R-7,200	Residential 7,200 sq. ft.	SFR-Basic
16 110904 RK	R-7,200	Residential 7,200 sq. ft.	SFR-Basic
16 111124 RK	R-7,200	Residential 7,200 sq. ft.	SFR-Basic
16 111125 RK	R-7,200	Residential 7,200 sq. ft.	SFR-Basic
16 111126 RK	R-7,200	Residential 7,200 sq. ft.	SFR-Basic
16 120368 RK	R-7,200	Residential 7,200 sq. ft.	SFR-Basic
16 118542 RK	R-7,200	Residential 7,200 sq. ft.	SFR-Basic
16 118543 RK	R-7,200	Residential 7,200 sq. ft.	SFR-Basic
16 118303 RK	R-7,200	Residential 7,200 sq. ft.	SFR-Basic
16 111127 RK	R-7,200	Residential 7,200 sq. ft.	SFR-Basic
16 107813 RK	R-5	Rural-5 Acre	SFR-Basic
16 113977 RK	R-5	Rural-5 Acre	Single Family Residential
16 110882 RK	R-5	Rural-5 Acre	Single Family Residential

Accessory Dwelling Units

Index # - File Name: 1.0022 - Single Family Dwellings Data\_Snohomish County.pdf

16 107818 RK	R-5	Rural-5 Acre	SFR-Basic
16 107815 RK	R-5	Rural-5 Acre	SFR-Basic
16 107817 RK	R-5	Rural-5 Acre	SFR-Basic
16 106764 RK	R-5	Rural-5 Acre	SFR-Basic
16 102239 RK	R-5	Rural-5 Acre	SFR-Basic
16 111169 RK	R-5	Rural-5 Acre	Single Family Residential
16 110707 RK	R-5	Rural-5 Acre	SFR-Basic
16 110713 RK	R-5	Rural-5 Acre	SFR-Basic
16 105285 RK	R-5	Rural-5 Acre	SFR-Basic
16 111039 RK	R-8,400(PRD)	Residential 8,400 sq. ft.	SFR-Basic
16 111040 RK	R-8,400(PRD)	Residential 8,400 sq. ft.	SFR-Basic
16 111041 RK	R-8,400(PRD)	Residential 8,400 sq. ft.	SFR-Basic
16 110916 RK	R-8,400(PRD)	Residential 8,400 sq. ft.	SFR-Basic
16 110917 RK	R-8,400(PRD)	Residential 8,400 sq. ft.	SFR-Basic
16 110918 RK	R-8,400(PRD)	Residential 8,400 sq. ft.	SFR-Basic
16 110919 RK	R-8,400(PRD)	Residential 8,400 sq. ft.	SFR-Basic
16 110920 RK	R-8,400(PRD)	Residential 8,400 sq. ft.	SFR-Basic
16 110921 RK	R-8,400(PRD)	Residential 8,400 sq. ft.	SFR-Basic
16 110922 RK	R-8,400(PRD)	Residential 8,400 sq. ft.	SFR-Basic
16 110923 RK	R-8,400(PRD)	Residential 8,400 sq. ft.	SFR-Basic
16 110924 RK	R-8,400(PRD)	Residential 8,400 sq. ft.	SFR-Basic
16 110925 RK	R-8,400(PRD)	Residential 8,400 sq. ft.	SFR-Basic
16 110926 RK	R-8,400(PRD)	Residential 8,400 sq. ft.	SFR-Basic
16 110927 RK	R-8,400(PRD)	Residential 8,400 sq. ft.	SFR-Basic
16 110928 RK	R-8,400(PRD)	Residential 8,400 sq. ft.	SFR-Basic
16 110929 RK	R-8,400(PRD)	Residential 8,400 sq. ft.	SFR-Basic
16 110930 RK	R-8,400(PRD)	Residential 8,400 sq. ft.	SFR-Basic
16 110931 RK	R-8,400(PRD)	Residential 8,400 sq. ft.	SFR-Basic
16 110932 RK	R-8,400(PRD)	Residential 8,400 sq. ft.	SFR-Basic
16 110933 RK	R-8,400(PRD)	Residential 8,400 sq. ft.	SFR-Basic
16 110934 RK	R-8,400(PRD)	Residential 8,400 sq. ft.	SFR-Basic
16 110935 RK	R-8,400(PRD)	Residential 8,400 sq. ft.	SFR-Basic
16 110936 RK	R-8,400(PRD)	Residential 8,400 sq. ft.	SFR-Basic
16 110937 RK	R-8,400(PRD)	Residential 8,400 sq. ft.	SFR-Basic
16 110938 RK	R-8,400(PRD)	Residential 8,400 sq. ft.	SFR-Basic
16 110939 RK	R-8,400(PRD)	Residential 8,400 sq. ft.	SFR-Basic
16 110940 RK	R-8,400(PRD)	Residential 8,400 sq. ft.	SFR-Basic
16 110941 RK	R-8,400(PRD)	Residential 8,400 sq. ft.	SFR-Basic
16 110942 RK	R-8,400(PRD)	Residential 8,400 sq. ft.	SFR-Basic
16 110943 RK	R-8,400(PRD)	Residential 8,400 sq. ft.	SFR-Basic
16 110944 RK	R-8,400(PRD)	Residential 8,400 sq. ft.	SFR-Basic
16 110945 RK	R-8,400(PRD)	Residential 8,400 sq. ft.	SFR-Basic
16 110946 RK	R-8,400(PRD)	Residential 8,400 sq. ft.	SFR-Basic
16 110947 RK	R-8,400(PRD)	Residential 8,400 sq. ft.	SFR-Basic
16 110948 RK	R-8,400(PRD)	Residential 8,400 sq. ft.	SFR-Basic
16 110739 RK	R-8,400(PRD)	Residential 8,400 sq. ft.	SFR-Basic
16 110740 RK	R-8,400(PRD)	Residential 8,400 sq. ft.	SFR-Basic

Accessory Dwelling Units

Index # - File Name: 1.0022 - Single Family Dwellings Data\_Snohomish County.pdf

16 110741 RK	R-8,400(PRD)	Residential 8,400 sq. ft.	SFR-Basic
16 110736 RK	R-8,400(PRD)	Residential 8,400 sq. ft.	SFR-Basic
16 110737 RK	R-8,400(PRD)	Residential 8,400 sq. ft.	SFR-Basic
16 110738 RK	R-8,400(PRD)	Residential 8,400 sq. ft.	SFR-Basic
16 110909 RK	R-8,400(PRD)	Residential 8,400 sq. ft.	SFR-Basic
16 110910 RK	R-8,400(PRD)	Residential 8,400 sq. ft.	SFR-Basic
16 110911 RK	R-8,400(PRD)	Residential 8,400 sq. ft.	SFR-Basic
16 110912 RK	R-8,400(PRD)	Residential 8,400 sq. ft.	SFR-Basic
16 110913 RK	R-8,400(PRD)	Residential 8,400 sq. ft.	SFR-Basic
16 110914 RK	R-8,400(PRD)	Residential 8,400 sq. ft.	SFR-Basic
16 110915 RK	R-8,400(PRD)	Residential 8,400 sq. ft.	SFR-Basic
16 111035 RK	R-8,400(PRD)	Residential 8,400 sq. ft.	SFR-Basic
16 111036 RK	R-8,400(PRD)	Residential 8,400 sq. ft.	SFR-Basic
16 111037 RK	R-8,400(PRD)	Residential 8,400 sq. ft.	SFR-Basic
16 111038 RK	R-8,400(PRD)	Residential 8,400 sq. ft.	SFR-Basic
16 102255 RK	R-9,600	Residential 9,600 sq. ft.	Duplex
16 111032 RK	R-8,400(PRD)	Residential 8,400 sq. ft.	SFR-Basic
16 109516 RK	R-5	Rural-5 Acre	Single Family Residential
16 105549 RK	R-5	Rural-5 Acre	Single Family Residential
16 105395 RK	RRT-10	Rural Resource Transition-10	Single Family Residential
16 106063 RK	R-5	Rural-5 Acre	Single Family Residential
16 106064 RK	R-5	Rural-5 Acre	Single Family Residential
16 105987 RK	R-5	Rural-5 Acre	Single Family Residential
16 110693 RK	R-7,200	Residential 7,200 sq. ft.	Single Family Residential
16 110689 RK	R-7,200	Residential 7,200 sq. ft.	Single Family Residential
16 120659 RK	R-7,200	Residential 7,200 sq. ft.	Single Family Residential
16 110188 RK	R-5	Rural-5 Acre	Single Family Residential
16 110190 RK	R-5	Rural-5 Acre	Single Family Residential
16 110840 RK	R-5	Rural-5 Acre	SFR-Basic
16 114108 RK	R-7,200	Residential 7,200 sq. ft.	SFR-Basic
16 114109 RK	R-7,200	Residential 7,200 sq. ft.	SFR-Basic
16 114110 RK	R-7,200	Residential 7,200 sq. ft.	SFR-Basic
16 114015 RK	R-7,200	Residential 7,200 sq. ft.	SFR-Basic
16 120663 RK	R-7,200	Residential 7,200 sq. ft.	Single Family Residential
16 110841 RK	R-5	Rural-5 Acre	SFR-Basic
16 110839 RK	R-5	Rural-5 Acre	SFR-Basic
16 110843 RK	R-5	Rural-5 Acre	SFR-Basic
16 117710 RK	R-7,200	Residential 7,200 sq. ft.	SFR-Basic
16 116951 RK	R-7,200	Residential 7,200 sq. ft.	SFR-Basic
16 116952 RK	R-7,200	Residential 7,200 sq. ft.	SFR-Basic
16 116953 RK	R-7,200	Residential 7,200 sq. ft.	SFR-Basic
16 114016 RK	R-7,200	Residential 7,200 sq. ft.	SFR-Basic
16 114111 RK	R-7,200	Residential 7,200 sq. ft.	SFR-Basic
16 117346 RK	R-7,200	Residential 7,200 sq. ft.	SFR-Basic
16 117347 RK	R-7,200	Residential 7,200 sq. ft.	SFR-Basic
16 117348 RK	R-7,200	Residential 7,200 sq. ft.	SFR-Basic
16 117349 RK	R-7,200	Residential 7,200 sq. ft.	SFR-Basic

Accessory Dwelling Units

Index # - File Name: 1.0022 - Single Family Dwellings Data\_Snohomish County.pdf

16 117350 RK	R-7,200	Residential 7,200 sq. ft.	SFR-Basic
16 117351 RK	R-7,200	Residential 7,200 sq. ft.	SFR-Basic
16 114017 RK	R-7,200	Residential 7,200 sq. ft.	SFR-Basic
16 114112 RK	R-7,200	Residential 7,200 sq. ft.	SFR-Basic
16 114018 RK	R-7,200	Residential 7,200 sq. ft.	SFR-Basic
16 114113 RK	R-7,200	Residential 7,200 sq. ft.	SFR-Basic
16 117352 RK	R-7,200	Residential 7,200 sq. ft.	SFR-Basic
16 117353 RK	R-7,200	Residential 7,200 sq. ft.	SFR-Basic
16 117354 RK	R-7,200	Residential 7,200 sq. ft.	SFR-Basic
16 117355 RK	R-7,200	Residential 7,200 sq. ft.	SFR-Basic
16 117356 RK	R-7,200	Residential 7,200 sq. ft.	SFR-Basic
16 117357 RK	R-7,200	Residential 7,200 sq. ft.	SFR-Basic
16 117358 RK	R-7,200	Residential 7,200 sq. ft.	SFR-Basic
16 117359 RK	R-7,200	Residential 7,200 sq. ft.	SFR-Basic
16 117360 RK	R-7,200	Residential 7,200 sq. ft.	SFR-Basic
16 117361 RK	R-7,200	Residential 7,200 sq. ft.	SFR-Basic
16 118984 RK	R-7,200	Residential 7,200 sq. ft.	SFR-Basic
16 106684 RK	R-5	Rural-5 Acre	Single Family Residential
16 107255 RK	R-7,200 : R-9,€	Residential 7,200 sq. ft. : Re	Single Family Residential
16 107260 RK	R-7,200 : R-9,€	Residential 7,200 sq. ft. : Re	Single Family Residential
16 107259 RK	R-7,200 : R-9,€	Residential 7,200 sq. ft. : Re	Single Family Residential
16 107261 RK	R-7,200 : R-9,€	Residential 7,200 sq. ft. : Re	Single Family Residential
16 107891 RK	LDMR : PRD-LI	Low Density Multiple Reside	Single Family Residential
16 110298 RK	LDMR : NB : Pf	Low Density Multiple Reside	Duplex-Basic
16 110299 RK	LDMR : NB : Pf	Low Density Multiple Reside	SFR-Basic
16 110300 RK	LDMR : NB : Pf	Low Density Multiple Reside	Duplex-Basic
16 110301 RK	LDMR : NB : Pf	Low Density Multiple Reside	SFR-Basic
16 110302 RK	LDMR : NB : Pf	Low Density Multiple Reside	SFR-Basic
16 110303 RK	LDMR : NB : Pf	Low Density Multiple Reside	Duplex-Basic
16 110304 RK	LDMR : NB : Pf	Low Density Multiple Reside	SFR-Basic
16 110305 RK	LDMR : NB : Pf	Low Density Multiple Reside	Duplex-Basic
16 110306 RK	LDMR : NB : Pf	Low Density Multiple Reside	SFR-Basic
16 110307 RK	LDMR : NB : Pf	Low Density Multiple Reside	Duplex-Basic
16 110308 RK	LDMR : NB : Pf	Low Density Multiple Reside	SFR-Basic
16 110309 RK	LDMR : NB : Pf	Low Density Multiple Reside	SFR-Basic
16 110310 RK	LDMR : NB : Pf	Low Density Multiple Reside	SFR-Basic
16 109900 RK	LDMR : NB : Pf	Low Density Multiple Reside	Duplex-Basic
16 109901 RK	LDMR : NB : Pf	Low Density Multiple Reside	SFR-Basic
16 109902 RK	LDMR : NB : Pf	Low Density Multiple Reside	Duplex-Basic
16 109903 RK	LDMR : NB : Pf	Low Density Multiple Reside	SFR-Basic
16 109904 RK	LDMR : NB : Pf	Low Density Multiple Reside	Duplex-Basic
16 109905 RK	LDMR : NB : Pf	Low Density Multiple Reside	SFR-Basic
16 109906 RK	LDMR : NB : Pf	Low Density Multiple Reside	SFR-Basic
16 109907 RK	LDMR : NB : Pf	Low Density Multiple Reside	SFR-Basic
16 109908 RK	LDMR : NB : Pf	Low Density Multiple Reside	Duplex-Basic
16 120289 RK	R-7,200(PRD)	Residential 7,200 sq. ft.	SFR-Basic
16 119403 RK	R-7,200(PRD)	Residential 7,200 sq. ft.	Single Family Residential



Accessory Dwelling Units

Index # - File Name: 1.0022 - Single Family Dwellings Data\_Snohomish County.pdf

16 121629 RK	R-7,200(PRD)	Residential 7,200 sq. ft.	SFR-Basic
16 115066 RK	R-7,200(PRD)	Residential 7,200 sq. ft.	SFR-Basic
16 116096 RK	R-7,200(PRD)	Residential 7,200 sq. ft.	SFR-Basic
16 116097 RK	R-7,200(PRD)	Residential 7,200 sq. ft.	SFR-Basic
16 115067 RK	R-7,200(PRD)	Residential 7,200 sq. ft.	SFR-Basic
16 115068 RK	R-7,200(PRD)	Residential 7,200 sq. ft.	SFR-Basic
16 116098 RK	R-7,200(PRD)	Residential 7,200 sq. ft.	SFR-Basic
16 116901 RK	R-7,200(PRD)	Residential 7,200 sq. ft.	SFR-Basic
16 116099 RK	R-7,200(PRD)	Residential 7,200 sq. ft.	SFR-Basic
16 116100 RK	R-7,200(PRD)	Residential 7,200 sq. ft.	SFR-Basic
16 116101 RK	R-7,200(PRD)	Residential 7,200 sq. ft.	SFR-Basic
16 116102 RK	R-7,200(PRD)	Residential 7,200 sq. ft.	SFR-Basic
16 116103 RK	R-7,200(PRD)	Residential 7,200 sq. ft.	SFR-Basic
16 117602 RK	R-7,200(PRD)	Residential 7,200 sq. ft.	SFR-Basic
16 116104 RK	R-7,200(PRD)	Residential 7,200 sq. ft.	SFR-Basic
16 116105 RK	R-7,200(PRD)	Residential 7,200 sq. ft.	SFR-Basic
16 117603 RK	R-7,200(PRD)	Residential 7,200 sq. ft.	SFR-Basic
16 117604 RK	R-7,200(PRD)	Residential 7,200 sq. ft.	SFR-Basic
16 116106 RK	R-7,200(PRD)	Residential 7,200 sq. ft.	SFR-Basic
16 118293 RK	R-7,200(PRD)	Residential 7,200 sq. ft.	SFR-Basic
16 119483 RK	R-7,200(PRD)	Residential 7,200 sq. ft.	SFR-Basic
16 118294 RK	R-7,200(PRD)	Residential 7,200 sq. ft.	SFR-Basic
16 118295 RK	R-7,200(PRD)	Residential 7,200 sq. ft.	SFR-Basic
16 119484 RK	R-7,200(PRD)	Residential 7,200 sq. ft.	SFR-Basic
16 118296 RK	R-7,200(PRD)	Residential 7,200 sq. ft.	SFR-Basic
16 118297 RK	R-7,200(PRD)	Residential 7,200 sq. ft.	SFR-Basic
16 118298 RK	R-7,200(PRD)	Residential 7,200 sq. ft.	SFR-Basic
16 109039 RK	R-7,200 : R-7,2	Residential 7,200 sq. ft. : Res	Single Family Residential
16 109038 RK	R-7,200 : R-7,2	Residential 7,200 sq. ft. : Res	Single Family Residential
16 109036 RK	R-7,200 : R-7,2	Residential 7,200 sq. ft. : Res	Single Family Residential
16 108849 RK	R-5	Rural-5 Acre	SFR-Basic
16 109913 RK	R-5	Rural-5 Acre	SFR-Basic
16 109627 RK	R-5	Rural-5 Acre	SFR-Basic
16 109629 RK	R-5	Rural-5 Acre	Single Family Residential
16 109633 RK	R-5	Rural-5 Acre	SFR-Basic
16 107467 RK	LDMR : R-8,40	Low Density Multiple Reside	Single Family Residential
16 107469 RK	LDMR : R-8,40	Low Density Multiple Reside	Single Family Residential
16 107470 RK	LDMR : R-8,40	Low Density Multiple Reside	Single Family Residential
16 107390 RK	R-5	Rural-5 Acre	Single Family Residential
16 107985 RK	R-5	Rural-5 Acre	Single Family Residential
16 108192 RK	R-5	Rural-5 Acre	Single Family Residential
16 110849 RK	R-5	Rural-5 Acre	SFR-Basic
16 120287 RK	R-7,200(PRD)	Residential 7,200 sq. ft.	SFR-Basic
16 120288 RK	R-7,200(PRD)	Residential 7,200 sq. ft.	SFR-Basic
16 108651 000 01 RK	R-5	Rural-5 Acre	Single Family Residential
16 108713 RK	R-5	Rural-5 Acre	Single Family Residential
16 114853 RK	R-7,200	Residential 7,200 sq. ft.	Single Family Residential

Accessory Dwelling Units

Index # - File Name: 1.0022 - Single Family Dwellings Data\_Snohomish County.pdf

16 114854 RK	R-7,200	Residential 7,200 sq. ft.	Single Family Residential
16 109914 RK	R-5	Rural-5 Acre	SFR-Basic
16 109927 RK	R-5	Rural-5 Acre	SFR-Basic
16 109930 RK	R-5	Rural-5 Acre	Single Family Residential
16 109931 RK	R-5	Rural-5 Acre	SFR-Basic
16 109432 RK	R-7,200	Residential 7,200 sq. ft.	Duplex
16 111723 RK	F	Forestry	SFR-Basic
16 110014 RK	RRT-10	Rural Resource Transition-1	SFR-Basic
16 110015 RK	RRT-10	Rural Resource Transition-1	SFR-Basic
16 116847 RK	RRT-10	Rural Resource Transition-1	Single Family Residential
16 116843 RK	RRT-10	Rural Resource Transition-1	Single Family Residential
16 110076 RK	RRT-10	Rural Resource Transition-1	Single Family Residential
16 110453 RK	LDMR : R-7,20 Low Density Multiple Reside SFR-Basic		
16 110475 RK	LDMR : R-7,20 Low Density Multiple Reside SFR-Basic		
16 110455 RK	LDMR : R-7,20 Low Density Multiple Reside SFR-Basic		
16 110476 RK	LDMR : R-7,20 Low Density Multiple Reside SFR-Basic		
16 110456 RK	LDMR : R-7,20 Low Density Multiple Reside SFR-Basic		
16 110477 RK	LDMR : R-7,20 Low Density Multiple Reside SFR-Basic		
16 110457 RK	LDMR : R-7,20 Low Density Multiple Reside SFR-Basic		
16 110478 RK	LDMR : R-7,20 Low Density Multiple Reside SFR-Basic		
16 110459 RK	LDMR : R-7,20 Low Density Multiple Reside SFR-Basic		
16 110479 RK	LDMR : R-7,20 Low Density Multiple Reside SFR-Basic		
16 110461 RK	LDMR : R-7,20 Low Density Multiple Reside SFR-Basic		
16 110480 RK	LDMR : R-7,20 Low Density Multiple Reside SFR-Basic		
16 110462 RK	LDMR : R-7,20 Low Density Multiple Reside SFR-Basic		
16 110482 RK	LDMR : R-7,20 Low Density Multiple Reside SFR-Basic		
16 110465 RK	LDMR : R-7,20 Low Density Multiple Reside SFR-Basic		
16 110484 RK	LDMR : R-7,20 Low Density Multiple Reside SFR-Basic		
16 110466 RK	LDMR : R-7,20 Low Density Multiple Reside SFR-Basic		
16 110485 RK	LDMR : R-7,20 Low Density Multiple Reside SFR-Basic		
16 110468 RK	LDMR : R-7,20 Low Density Multiple Reside SFR-Basic		
16 110486 RK	LDMR : R-7,20 Low Density Multiple Reside SFR-Basic		
16 110469 RK	LDMR : R-7,20 Low Density Multiple Reside SFR-Basic		
16 110487 RK	LDMR : R-7,20 Low Density Multiple Reside SFR-Basic		
16 110444 RK	LDMR : R-7,20 Low Density Multiple Reside SFR-Basic		
16 110445 RK	LDMR : R-7,20 Low Density Multiple Reside SFR-Basic		
16 110446 RK	LDMR : R-7,20 Low Density Multiple Reside SFR-Basic		
16 110447 RK	LDMR : R-7,20 Low Density Multiple Reside SFR-Basic		
16 110448 RK	LDMR : R-7,20 Low Density Multiple Reside SFR-Basic		
16 110449 RK	LDMR : R-7,20 Low Density Multiple Reside SFR-Basic		
16 111800 RK	R-5	Rural-5 Acre	Single Family Residential
16 110391 RK	R-5	Rural-5 Acre	SFR-Basic
16 110392 000 01 RK	R-5	Rural-5 Acre	SFR-Basic
16 110473 RK	LDMR : R-7,20 Low Density Multiple Reside SFR-Basic		
16 110450 RK	LDMR : R-7,20 Low Density Multiple Reside SFR-Basic		
16 110474 RK	LDMR : R-7,20 Low Density Multiple Reside SFR-Basic		
16 113296 RK	R-5	Rural-5 Acre	Single Family Residential

Accessory Dwelling Units

Index # - File Name: 1.0022 - Single Family Dwellings Data\_Snohomish County.pdf

16 118436 RK	R-5	Rural-5 Acre	Single Family Residential
16 111118 RK	A-10	Agriculture-10 Acre	Single Family Residential
16 111063 RK	R-5	Rural-5 Acre	SFR-Basic
16 111055 RK	R-5	Rural-5 Acre	SFR-Basic
16 111065 RK	R-5	Rural-5 Acre	SFR-Basic
16 111064 RK	R-5	Rural-5 Acre	SFR-Basic
16 111057 RK	R-5	Rural-5 Acre	SFR-Basic
16 111059 RK	R-5	Rural-5 Acre	SFR-Basic
16 101570 RK	R-5	Rural-5 Acre	SFR-Basic
16 101569 RK	R-5	Rural-5 Acre	SFR-Basic
16 101566 RK	R-5	Rural-5 Acre	SFR-Basic
16 101568 RK	R-5	Rural-5 Acre	SFR-Basic
16 101571 RK	R-5	Rural-5 Acre	SFR-Basic
16 101572 RK	R-5	Rural-5 Acre	SFR-Basic
16 101565 RK	R-5	Rural-5 Acre	SFR-Basic
16 111061 RK	R-5	Rural-5 Acre	SFR-Basic
16 115452 RK	PRD-9,600	Residential 9,600 sq. ft.	Single Family Residential
15 117436 RK	MR : R-8,400	Multiple Residential : Reside	SFR-Basic
15 117437 RK	MR : R-8,400	Multiple Residential : Reside	SFR-Basic
15 117438 RK	MR : R-8,400	Multiple Residential : Reside	SFR-Basic
15 117439 RK	MR : R-8,400	Multiple Residential : Reside	SFR-Basic
15 117440 RK	MR : R-8,400	Multiple Residential : Reside	SFR-Basic
15 117441 RK	MR : R-8,400	Multiple Residential : Reside	SFR-Basic
16 108992 000 01 RK	R-5	Rural-5 Acre	Single Family Residential
16 110986 000 01 RK	R-5	Rural-5 Acre	Single Family Residential
16 103228 RK	R-5	Rural-5 Acre	SFR-Basic
15 118620 MH	A-10	Agriculture-10 Acre	Double Wide
16 103231 RK	R-5	Rural-5 Acre	SFR-Basic
16 103232 RK	R-5	Rural-5 Acre	SFR-Basic
16 103227 RK	R-5	Rural-5 Acre	SFR-Basic
16 105553 RK	R-5	Rural-5 Acre	Single Family Residential
16 108399 RK	R-5	Rural-5 Acre	Single Family Residential
15 119651 RK	R-5	Rural-5 Acre	Single Family Residential
16 102474 RK	R-5	Rural-5 Acre	Single Family Residential
16 104278 RK	RRT-10	Rural Resource Transition-10	Single Family Residential
15 114729 RK	R-5	Rural-5 Acre	Single Family Residential
15 113681 RK	R-5	Rural-5 Acre	SFR-Basic
16 111146 000 01 RK	F	Forestry	Single Family Residential
16 108019 RK	R-5	Rural-5 Acre	Single Family Residential
14 114103 RK	R-5	Rural-5 Acre	Single Family Residential
16 114926 000 01 RK	R-5	Rural-5 Acre	Single Family Residential
16 104214 RK	R-5	Rural-5 Acre	Single Family Residential
16 100389 RK	MR	Multiple Residential	SFR-Basic
16 100390 RK	MR	Multiple Residential	SFR-Basic
16 100391 RK	MR	Multiple Residential	SFR-Basic
16 100392 RK	MR	Multiple Residential	SFR-Basic
15 116267 RK	R-5	Rural-5 Acre	Single Family Residential

Accessory Dwelling Units

Index # - File Name: 1.0022 - Single Family Dwellings Data\_Snohomish County.pdf

16 110905 RK	R-5	Rural-5 Acre	Single Family Residential
16 110908 RK	R-5	Rural-5 Acre	Single Family Residential
16 103646 RK	R-5	Rural-5 Acre	Single Family Residential
16 102399 RK	R-5	Rural-5 Acre	Single Family Residential
15 118686 RK	RRT-10	Rural Resource Transition-10	Single Family Residential
16 100766 RK	RRT-10	Rural Resource Transition-10	Single Family Residential
15 115249 RK	R-5	Rural-5 Acre	Single Family Residential
16 103373 RK	R-5	Rural-5 Acre	Single Family Residential
16 110963 RK	RRT-10	Rural Resource Transition-10	Single Family Residential
16 103809 MH	A-10	Agriculture-10 Acre	Single Wide
16 103274 RK	R-5	Rural-5 Acre	Single Family Residential
15 114388 RK	R-5	Rural-5 Acre	Single Family Residential
16 106744 RK	R-5	Rural-5 Acre	Single Family Residential
16 114828 RK	MR	Multiple Residential	SFR-Basic
16 115640 RK	MR	Multiple Residential	Single Family Residential
16 114829 RK	MR	Multiple Residential	Single Family Residential
16 114826 RK	MR	Multiple Residential	SFR-Basic
15 118176 RK	R-5	Rural-5 Acre	Single Family Residential
16 107548 RK	R-5	Rural-5 Acre	Single Family Residential
15 117622 RK	R-5	Rural-5 Acre	Single Family Residential
16 116833 RK	R-5	Rural-5 Acre	Single Family Residential
16 113912 RK	R-5	Rural-5 Acre	Single Family Residential
16 111691 MH	A-10	Agriculture-10 Acre	Triple Wide
16 110625 RK	R-5	Rural-5 Acre	Single Family Residential
16 110368 RK	R-5	Rural-5 Acre	Single Family Residential
16 100316 MH	MHP	Mobile Home Park	MH Park-Triple Wide
16 115907 RK	R-5	Rural-5 Acre	Single Family Residential
16 101050 RK	R-5	Rural-5 Acre	Single Family Residential
15 115410 RK	R-5	Rural-5 Acre	Single Family Residential
16 108484 RK	R-5	Rural-5 Acre	SFR-Basic
15 115407 RK	R-5	Rural-5 Acre	Single Family Residential
15 117390 RK	R-5	Rural-5 Acre	Single Family Residential
16 106167 RK	R-5	Rural-5 Acre	Single Family Residential
16 118171 000 01 RK	R-7,200	Residential 7,200 sq. ft.	Single Family Residential
15 111545 RK	R-5	Rural-5 Acre	SFR-Basic
16 110187 RK	R-5	Rural-5 Acre	Single Family Residential
16 113323 000 01 RK	R-5	Rural-5 Acre	Single Family Residential
15 115198 RK	R-5	Rural-5 Acre	Single Family Residential
15 107740 RK	R-5	Rural-5 Acre	Single Family Residential
16 115570 RK	R-5	Rural-5 Acre	Single Family Residential
15 119676 RK	R-5	Rural-5 Acre	Single Family Residential
16 102256 RK	F	Forestry	Single Family Residential
14 105680 RK	A-10	Agriculture-10 Acre	Single Family Residential
16 102976 MH	MC	Mineral Conservation	Double Wide
15 114365 RK	R-9,600	Residential 9,600 sq. ft.	Single Family Residential
15 119454 RK	R-9,600	Residential 9,600 sq. ft.	Single Family Residential
16 109739 RK	R-5	Rural-5 Acre	Single Family Residential

Accessory Dwelling Units

Index # - File Name: 1.0022 - Single Family Dwellings Data\_Snohomish County.pdf

16 114204 RK	R-5	Rural-5 Acre	Single Family Residential
15 103480 MH	R-5	Rural-5 Acre	Double Wide
16 106902 RK	R-5	Rural-5 Acre	Single Family Residential
16 107241 RK	R-5	Rural-5 Acre	Single Family Residential
16 108337 RK	R-5	Rural-5 Acre	Single Family Residential
16 103710 MH	MHP	Mobile Home Park	MH Park-Double Wide
16 102643 MH	MHP	Mobile Home Park	MH Park-Double Wide
16 114876 MH	MHP	Mobile Home Park	MH Park-Double Wide
16 108848 MH	MHP	Mobile Home Park	MH Park-Double Wide
15 117855 MH	MHP	Mobile Home Park	MH Park-Double Wide
16 103711 MH	MHP	Mobile Home Park	MH Park-Double Wide
16 102920 MH	MHP	Mobile Home Park	MH Park-Double Wide
15 116169 MH	MHP	Mobile Home Park	MH Park-Triple Wide
16 105465 RK	R-5	Rural-5 Acre	Single Family Residential
15 118755 RK	R-5	Rural-5 Acre	Single Family Residential
16 114209 RK	R-5	Rural-5 Acre	Single Family Residential
16 111333 MH	R-5	Rural-5 Acre	Double Wide
16 115522 MH	R-5	Rural-5 Acre	MH Park-Double Wide
16 107082 RK	R-5	Rural-5 Acre	Single Family Residential
16 101663 RK	R-5	Rural-5 Acre	Single Family Residential
15 117069 RK	R-5	Rural-5 Acre	Single Family Residential
16 110338 RK	R-5	Rural-5 Acre	Single Family Residential
16 115316 RK	R-5	Rural-5 Acre	Single Family Residential
16 114815 RK	A-10 : R-5	Agriculture-10 Acre : Rural-5	Single Family Residential
16 106760 RK	R-5	Rural-5 Acre	SFR-Basic
15 119349 RK	R-7,200	Residential 7,200 sq. ft.	Single Family Residential
16 103905 RK	R-5	Rural-5 Acre	Single Family Residential
15 118957 RK	CRC	Clearview Rural Commercial	Single Family Residential
16 110907 RK	F	Forestry	Single Family Residential
16 109986 RK	R-5	Rural-5 Acre	Single Family Residential
16 108339 RK	R-5	Rural-5 Acre	Single Family Residential
16 106310 RK	R-5	Rural-5 Acre	Accessory Apt Detached
16 101078 RK	R-5	Rural-5 Acre	Single Family Residential
16 110723 RK	R-5	Rural-5 Acre	Single Family Residential
16 110822 000 01 RK	R-5	Rural-5 Acre	Single Family Residential
15 118214 MH	F	Forestry	Double Wide
16 105986 RK	R-5	Rural-5 Acre	Single Family Residential
16 109265 RK	R-5	Rural-5 Acre	Single Family Residential
15 115857 RK	R-5	Rural-5 Acre	Single Family Residential
15 119681 RK	R-5	Rural-5 Acre	Single Family Residential
16 108541 RK	R-5	Rural-5 Acre	Single Family Residential
16 109628 RK	R-5	Rural-5 Acre	Single Family Residential
16 105483 RK	R-8,400	Residential 8,400 sq. ft.	Single Family Residential
16 114646 RK	R-5	Rural-5 Acre	Single Family Residential
16 108715 RK	R-5	Rural-5 Acre	Single Family Residential
15 115291 RK	R-5	Rural-5 Acre	Single Family Residential
16 110990 RK	R-5	Rural-5 Acre	Single Family Residential

Accessory Dwelling Units

Index # - File Name: 1.0022 - Single Family Dwellings Data\_Snohomish County.pdf

15 119695 RK	R-7,200	Residential 7,200 sq. ft.	Single Family Residential
15 102291 RK	WFB	Waterfront Beach	Single Family Residential
15 115373 RK	R-5	Rural-5 Acre	Single Family Residential
16 100253 RK	R-8,400 : R-9,600	Residential 8,400 sq. ft. : Residential 9,600 sq. ft.	Duplex-Basic
16 118674 RK	F	Forestry	Single Family Residential
16 118672 RK	F	Forestry	Single Family Residential
16 102663 RK	F	Forestry	SFR-Basic
16 108927 RK	F	Forestry	SFR-Basic
16 108929 RK	F	Forestry	SFR-Basic
16 100466 RK	PRD-20,000(M)	Residential 20,000 sq. ft.	Single Family Residential
16 110828 RK	R-5	Rural-5 Acre	Single Family Residential
16 103112 RK	R-5	Rural-5 Acre	Single Family Residential
16 115758 RK	PRD-20,000(M)	Residential 20,000 sq. ft.	Single Family Residential
16 103979 RK	R-9,600	Residential 9,600 sq. ft.	Single Family Residential
16 106211 RK	R-5	Rural-5 Acre	Single Family Residential
16 105038 RK	R-5	Rural-5 Acre	Single Family Residential
15 118129 RK	R-5	Rural-5 Acre	Single Family Residential
15 115868 000 01 RK	R-8,400	Residential 8,400 sq. ft.	Single Family Residential
15 118854 RK	R-12,500	Residential 12,500 sq. ft.	Single Family Residential
16 110976 000 01 RK	R-7,200	Residential 7,200 sq. ft.	Single Family Residential
15 111327 000 01 RK	CB	Community Business	Duplex
16 106162 RK	PRD-7,200 : R-9,600	Residential 7,200 sq. ft. : Residential 9,600 sq. ft.	Duplex-Basic
16 107024 RK	R-8,400	Residential 8,400 sq. ft.	Single Family Residential
16 119362 RK	R-5	Rural-5 Acre	Single Family Residential
16 105488 RK	R-5	Rural-5 Acre	SFR-Basic
16 104981 RK	R-5	Rural-5 Acre	Single Family Residential
15 110183 RK	R-5	Rural-5 Acre	Single Family Residential
16 101180 RK	R-5	Rural-5 Acre	Single Family Residential
15 118177 RK	R-5	Rural-5 Acre	Single Family Residential
16 114060 RK	R-5	Rural-5 Acre	Single Family Residential
16 114367 RK	R-5	Rural-5 Acre	Single Family Residential
16 118944 RK	R-7,200 : R-9,600	Residential 7,200 sq. ft. : Residential 9,600 sq. ft.	Single Family Residential
16 107656 RK	R-5	Rural-5 Acre	Single Family Residential
16 103450 RK	R-5	Rural-5 Acre	Single Family Residential
16 105124 RK	R-5	Rural-5 Acre	Single Family Residential
16 107234 RK	R-9,600	Residential 9,600 sq. ft.	Single Family Residential
16 119342 RK	PRD-20,000(M)	Residential 20,000 sq. ft.	Single Family Residential
16 103371 RK	R-5	Rural-5 Acre	Single Family Residential
16 106755 RK	R-5	Rural-5 Acre	Single Family Residential
16 104294 RK	R-5	Rural-5 Acre	Accessory Apt Detached
15 118262 RK	R-9,600	Residential 9,600 sq. ft.	Single Family Residential
16 105974 RK	A-10	Agriculture-10 Acre	Single Family Residential
16 102127 RK	R-5	Rural-5 Acre	Single Family Residential
16 106597 RK	R-5	Rural-5 Acre	Accessory Apt Detached
16 106799 RK	R-5	Rural-5 Acre	Single Family Residential
16 112072 RK	R-7,200	Residential 7,200 sq. ft.	Single Family Residential
15 106911 RK	R-9,600	Residential 9,600 sq. ft.	Single Family Residential

Accessory Dwelling Units

Index # - File Name: 1.0022 - Single Family Dwellings Data\_Snohomish County.pdf

15 113949 RK	R-5	Rural-5 Acre	Single Family Residential
15 113954 RK	R-5	Rural-5 Acre	Single Family Residential
15 113956 RK	R-5	Rural-5 Acre	Single Family Residential
16 110274 RK	R-8,400	Residential 8,400 sq. ft.	Single Family Residential
15 110190 RK	R-8,400	Residential 8,400 sq. ft.	Single Family Residential
16 108219 RK	R-7,200	Residential 7,200 sq. ft.	Single Family Residential
15 119423 RK	WFB	Waterfront Beach	SFR-Basic
15 107287 RK	R-7,200	Residential 7,200 sq. ft.	Duplex
15 117371 RK	R-5	Rural-5 Acre	Single Family Residential
16 113061 MH	RRT-10	Rural Resource Transition-10	Triple Wide
16 109399 MH	RRT-10	Rural Resource Transition-10	Double Wide
16 101067 RK	R-5	Rural-5 Acre	SFR-Basic
16 101074 RK	R-5	Rural-5 Acre	SFR-Basic
16 101063 RK	R-5	Rural-5 Acre	SFR-Basic
16 101070 RK	R-5	Rural-5 Acre	SFR-Basic
15 109475 000 01 RK	RRT-10	Rural Resource Transition-10	Single Family Residential
16 102128 RK	R-7,200	Residential 7,200 sq. ft.	Single Family Residential
15 118876 RK	R-5	Rural-5 Acre	Single Family Residential
16 102246 RK	R-5	Rural-5 Acre	Single Family Residential
16 109772 MH	R-5	Rural-5 Acre	Double Wide
16 107058 RK	R-5	Rural-5 Acre	Single Family Residential
16 103975 RK	R-5	Rural-5 Acre	Single Family Residential
16 104381 RK	R-5	Rural-5 Acre	Single Family Residential
16 100348 RK	R-5	Rural-5 Acre	Single Family Residential
16 115134 RK	R-5	Rural-5 Acre	Single Family Residential
16 115110 MH	R-5	Rural-5 Acre	Double Wide
15 111226 000 01 RK	RRT-10	Rural Resource Transition-10	Single Family Residential
16 110845 MH	R-5	Rural-5 Acre	Double Wide
16 102074 RK	R-5	Rural-5 Acre	Single Family Residential
16 111898 MH	R-5	Rural-5 Acre	Double Wide
16 106283 RK	RRT-10	Rural Resource Transition-10	Single Family Residential
16 108400 RK	R-5	Rural-5 Acre	Single Family Residential
16 115195 RK	R-5	Rural-5 Acre	Single Family Residential
16 113388 MH	R-5	Rural-5 Acre	Double Wide
16 103454 MH	R-5	Rural-5 Acre	Single Wide
16 111134 RK	R-5	Rural-5 Acre	Single Family Residential
16 100514 RK	R-5	Rural-5 Acre	Single Family Residential
16 102167 RK	RC	Rural Conservation	Single Family Residential
16 117193 RK	R-5 : RC	Rural Conservation : Rural-5	Single Family Residential
16 116178 RK	R-5	Rural-5 Acre	Single Family Residential
16 109032 MH	R-5	Rural-5 Acre	Triple Wide
15 113742 RK	R-5	Rural-5 Acre	Single Family Residential
15 118146 RK	R-5	Rural-5 Acre	Single Family Residential
16 110176 RK	R-5	Rural-5 Acre	Single Family Residential
16 110579 000 01 RK	R-5	Rural-5 Acre	Single Family Residential
16 110752 RK	R-5	Rural-5 Acre	Single Family Residential
16 109727 RK	R-5	Rural-5 Acre	Single Family Residential

Accessory Dwelling Units

Index # - File Name: 1.0022 - Single Family Dwellings Data\_Snohomish County.pdf

16 103426 RK	R-5	Rural-5 Acre	Single Family Residential
16 104014 RK	A-10 : R-5	Agriculture-10 Acre : Rural-5	Single Family Residential
16 103894 MH	R-5	Rural-5 Acre	Triple Wide
16 108648 MH	R-5	Rural-5 Acre	Double Wide
16 105324 RK	R-5	Rural-5 Acre	Single Family Residential
16 117643 MH	A-10	Agriculture-10 Acre	Single Wide
16 107576 RK	R-5	Rural-5 Acre	Single Family Residential
16 106788 000 01 RK	RD	Rural Diversification	Single Family Residential
16 102463 RK	R-5	Rural-5 Acre	Single Family Residential
15 119555 RK	R-5	Rural-5 Acre	Single Family Residential
16 108211 RK	R-5	Rural-5 Acre	Single Family Residential
16 112220 RK	R-5	Rural-5 Acre	Single Family Residential
16 102067 000 01 RK	A-10	Agriculture-10 Acre	Single Family Residential
15 114026 RK	R-5	Rural-5 Acre	Single Family Residential
15 118441 RK	F	Forestry	Single Family Residential
16 103795 RK	R-5	Rural-5 Acre	Single Family Residential
16 114461 MH	R-5	Rural-5 Acre	Double Wide
15 118024 RK	R-5	Rural-5 Acre	Single Family Residential
15 119627 000 01 RK	R-5	Rural-5 Acre	Single Family Residential
16 114886 MH	A-10	Agriculture-10 Acre	Double Wide
16 113816 RK	R-5	Rural-5 Acre	Single Family Residential
15 111583 RK	R-9,600	Residential 9,600 sq. ft.	Single Family Residential
16 110641 RK	R-5	Rural-5 Acre	Single Family Residential
16 107402 RK	R-5	Rural-5 Acre	SFR-Basic
15 113764 RK	R-5	Rural-5 Acre	Single Family Residential
15 118475 RK	RB	Rural Business	Single Family Residential
15 119441 RK	R-5	Rural-5 Acre	Single Family Residential
16 109974 RK	RC	Rural Conservation	Single Family Residential
15 118347 000 01 RK	RRT-10	Rural Resource Transition-10	Single Family Residential
16 108922 RK	R-5	Rural-5 Acre	Single Family Residential
16 102141 RK	R-5	Rural-5 Acre	SFR-Basic
16 101040 RK	F and R	Forestry and Recreation	Single Family Residential
15 110507 RK	R-5	Rural-5 Acre	Single Family Residential
15 115159 RK	R-5 : RB	Rural Business : Rural-5 Acre	Single Family Residential
17 110365 RK	R-5	Rural-5 Acre	Duplex
16 119371 RK	R-5	Rural-5 Acre	Single Family Residential
17 106409 RK	R-5	Rural-5 Acre	Single Family Residential
17 108281 RK	R-7,200	Residential 7,200 sq. ft.	Single Family Residential
17 110808 RK	PRD-9,600	Residential 9,600 sq. ft.	Single Family Residential
17 112974 MH	R-5	Rural-5 Acre	Double Wide
17 103600 RK	R-5	Rural-5 Acre	Single Family Residential
17 118724 RK	R-5	Rural-5 Acre	Single Family Residential
17 105195 000 01 RK	R-9,600	Residential 9,600 sq. ft.	Single Family Residential
17 108129 RK	R-5	Rural-5 Acre	Single Family Residential
16 101053 RK	R-5	Rural-5 Acre	Single Family Residential
15 119913 RK	R-5	Rural-5 Acre	Single Family Residential
15 119915 RK	R-5	Rural-5 Acre	Single Family Residential



Accessory Dwelling Units

Index # - File Name: 1.0022 - Single Family Dwellings Data\_Snohomish County.pdf

16 117575 RK	R-5	Rural-5 Acre	Single Family Residential
17 101829 RK	R-5	Rural-5 Acre	Single Family Residential
16 111080 000 01 RK	RRT-10	Rural Resource Transition-10	Single Family Residential
17 113279 RK	R-5	Rural-5 Acre	SFR-Basic
17 116303 RK	R-5	Rural-5 Acre	Single Family Residential
16 117166 RK	R-5	Rural-5 Acre	Single Family Residential
16 106073 RK	R-5	Rural-5 Acre	SFR-Basic
17 108850 RK	R-5	Rural-5 Acre	Single Family Residential
16 120803 RK	R-5	Rural-5 Acre	Single Family Residential
17 100307 RK	R-5	Rural-5 Acre	Single Family Residential
17 103244 RK	R-5	Rural-5 Acre	Single Family Residential
16 110398 000 01 RK	R-5	Rural-5 Acre	Single Family Residential
17 115875 RK	R-5	Rural-5 Acre	Single Family Residential
17 115619 000 01 RK	R-5	Rural-5 Acre	Single Family Residential
16 118223 RK	R-5	Rural-5 Acre	Single Family Residential
17 115150 RK	R-5	Rural-5 Acre	Single Family Residential
17 112360 RK	R-5	Rural-5 Acre	Single Family Residential
17 107097 RK	R-5	Rural-5 Acre	Single Family Residential
17 108099 RK	R-5	Rural-5 Acre	Accessory Apt Detached
17 107434 RK	R-5	Rural-5 Acre	Single Family Residential
16 115616 RK	R-5	Rural-5 Acre	Single Family Residential
16 115923 RK	R-5	Rural-5 Acre	Single Family Residential
17 113582 RK	R-5	Rural-5 Acre	Single Family Residential
17 106414 MH	R-5	Rural-5 Acre	Single Wide
16 118644 RK	R-5	Rural-5 Acre	Single Family Residential
17 103063 000 01 RK	R-5	Rural-5 Acre	Single Family Residential
17 114526 000 01 RK	R-5	Rural-5 Acre	Single Family Residential
16 110021 000 01 RK	R-5	Rural-5 Acre	Single Family Residential
17 102101 RK	R-5	Rural-5 Acre	Single Family Residential
17 110531 RK	R-5	Rural-5 Acre	Single Family Residential
17 111789 RK	R-5	Rural-5 Acre	Single Family Residential
16 109284 RK	R-5	Rural-5 Acre	Single Family Residential
16 122061 RK	R-5	Rural-5 Acre	Single Family Residential
17 111191 RK	A-10 : R-5	Agriculture-10 Acre : Rural-5	Single Family Residential
16 110195 RK	R-5	Rural-5 Acre	Single Family Residential
17 107755 RK	RRT-10	Rural Resource Transition-10	Single Family Residential
17 106221 RK	R-5	Rural-5 Acre	Single Family Residential
17 101049 RK	R-5	Rural-5 Acre	Single Family Residential
17 110466 RK	R-5	Rural-5 Acre	Single Family Residential
16 121463 RK	R-5	Rural-5 Acre	Single Family Residential
17 108455 RK	R-5	Rural-5 Acre	Single Family Residential
17 104278 RK	R-5	Rural-5 Acre	Single Family Residential
17 110527 000 01 RK	R-5	Rural-5 Acre	Single Family Residential
17 108499 RK	R-5	Rural-5 Acre	Single Family Residential
17 113130 MH	R-5	Rural-5 Acre	Double Wide
17 100796 000 01 RK	R-5	Rural-5 Acre	Single Family Residential
16 121204 RK	R-5	Rural-5 Acre	Single Family Residential

Accessory Dwelling Units

Index # - File Name: 1.0022 - Single Family Dwellings Data\_Snohomish County.pdf

17 110705 RK	RRT-10	Rural Resource Transition-10	Single Family Residential
17 110454 RK	R-5	Rural-5 Acre	SFR-Basic
17 118722 RK	R-5	Rural-5 Acre	Single Family Residential
17 111189 000 01 RK	R-5	Rural-5 Acre	Single Family Residential
17 102757 RK	R-5	Rural-5 Acre	Single Family Residential
17 116003 MH	R-5	Rural-5 Acre	Double Wide
16 120225 RK	R-5	Rural-5 Acre	Single Family Residential
16 121040 RK	RRT-10	Rural Resource Transition-10	SFR-Basic
17 117041 RK	R-5	Rural-5 Acre	Single Family Residential
16 120800 MH	R-5	Rural-5 Acre	Double Wide
17 112930 RK	R-5	Rural-5 Acre	Single Family Residential
17 107363 RK	R-5	Rural-5 Acre	Duplex
17 101598 RK	R-5	Rural-5 Acre	Single Family Residential
17 107129 RK	R-7,200	Residential 7,200 sq. ft.	Single Family Residential
17 102005 RK	R-7,200	Residential 7,200 sq. ft.	Duplex
17 101712 RK	R-7,200	Residential 7,200 sq. ft.	Duplex
16 116241 RK	R-7,200	Residential 7,200 sq. ft.	Duplex
17 110901 RK	R-7,200	Residential 7,200 sq. ft.	Duplex
17 116436 MH	R-7,200	Residential 7,200 sq. ft.	Single Wide
17 107291 RK	R-5	Rural-5 Acre	Single Family Residential
17 100198 RK	R-8,400	Residential 8,400 sq. ft.	Single Family Residential
17 112681 RK	R-7,200	Residential 7,200 sq. ft.	Single Family Residential
17 104032 RK	R-8,400	Residential 8,400 sq. ft.	Single Family Residential
16 119411 RK	R-5	Rural-5 Acre	Single Family Residential
17 113154 RK	R-9,600	Residential 9,600 sq. ft.	Single Family Residential
16 120672 RK	CITY	City	Single Family Residential
17 109336 RK	R-9,600	Residential 9,600 sq. ft.	Single Family Residential
16 120472 RK	R-7,200	Residential 7,200 sq. ft.	Single Family Residential
17 107542 RK	R-5	Rural-5 Acre	Duplex
16 115097 000 01 RK	R-5	Rural-5 Acre	Single Family Residential
17 100341 MH	R-5	Rural-5 Acre	Double Wide
16 120190 RK	R-5	Rural-5 Acre	Accessory Apt Detached
17 110556 RK	R-5	Rural-5 Acre	Single Family Residential
16 115586 RK	R-5	Rural-5 Acre	Single Family Residential
17 103821 RK	R-5	Rural-5 Acre	Single Family Residential
17 112226 RK	R-5	Rural-5 Acre	Single Family Residential
17 112948 RK	R-5	Rural-5 Acre	Accessory Apt Attached
17 112406 RK	R-5	Rural-5 Acre	Single Family Residential
17 112993 000 01 RK	R-5	Rural-5 Acre	Single Family Residential
17 108707 MH	R-5	Rural-5 Acre	Double Wide
17 109521 MH	R-5	Rural-5 Acre	Double Wide
17 110927 RK	R-5	Rural-5 Acre	Single Family Residential
17 107903 RK	PRD SA-1	Suburban Agriculture-1 Acre	Single Family Residential
17 115070 RK	R-9,600	Residential 9,600 sq. ft.	Single Family Residential
17 109117 RK	R-9,600	Residential 9,600 sq. ft.	Accessory Apt Detached
17 103903 RK	R-5	Rural-5 Acre	SFR-Basic
17 112598 RK	R-9,600	Residential 9,600 sq. ft.	Single Family Residential

Accessory Dwelling Units

Index # - File Name: 1.0022 - Single Family Dwellings Data\_Snohomish County.pdf

17 114511 RK	R-5	Rural-5 Acre	Single Family Residential
17 115352 RK	R-5	Rural-5 Acre	Single Family Residential
17 102945 RK	R-5	Rural-5 Acre	Single Family Residential
17 102996 RK	R-5	Rural-5 Acre	Single Family Residential
17 111906 RK	R-5	Rural-5 Acre	SFR-Basic
17 102769 RK	F	Forestry	Single Family Residential
17 103540 RK	R-5	Rural-5 Acre	Single Family Residential
17 112168 RK	R-5	Rural-5 Acre	Single Family Residential
17 109192 000 01 RK	R-5	Rural-5 Acre	Single Family Residential
16 121340 RK	R-8,400	Residential 8,400 sq. ft.	Single Family Residential
17 104070 RK	R-12,500	Residential 12,500 sq. ft.	Single Family Residential
17 103290 RK	R-12,500	Residential 12,500 sq. ft.	Single Family Residential
17 103291 RK	R-12,500	Residential 12,500 sq. ft.	Single Family Residential
17 103697 RK	R-8,400	Residential 8,400 sq. ft.	Single Family Residential
17 100240 RK	R-9,600	Residential 9,600 sq. ft.	Single Family Residential
17 108140 RK	PRD-20,000(M	Residential 20,000 sq. ft.	Single Family Residential
17 102025 RK	PRD-20,000(M	Residential 20,000 sq. ft.	Single Family Residential
17 101486 RK	R-5	Rural-5 Acre	Single Family Residential
17 109282 RK	R-5	Rural-5 Acre	Single Family Residential
17 109572 RK	R-8,400	Residential 8,400 sq. ft.	Accessory Apt Detached
16 121192 RK	R-8,400	Residential 8,400 sq. ft.	Accessory Apt Detached
17 103236 RK	F	Forestry	SFR-Basic
17 103235 RK	F	Forestry	Single Family Residential
17 108817 RK	R-9,600	Residential 9,600 sq. ft.	Single Family Residential
17 112602 RK	R-7,200 : R-9,600	Residential 7,200 sq. ft. : Residential 9,600 sq. ft.	Duplex
17 100321 RK	LDMR	Low Density Multiple Residence	Single Family Residential
17 107745 RK	R-5	Rural-5 Acre	Single Family Residential
17 105132 MH	R-5	Rural-5 Acre	Double Wide
17 108185 RK	F	Forestry	Single Family Residential
17 109617 RK	R-5	Rural-5 Acre	Single Family Residential
17 115381 RK	R-5	Rural-5 Acre	Single Family Residential
17 107317 000 01 RK	R-5	Rural-5 Acre	Single Family Residential
17 100181 RK	R-5	Rural-5 Acre	Single Family Residential
16 116871 RK	R-9,600	Residential 9,600 sq. ft.	Single Family Residential
17 105252 RK	R-8,400	Residential 8,400 sq. ft.	Accessory Apt Detached
17 109018 RK	R-9,600	Residential 9,600 sq. ft.	Single Family Residential
17 112668 RK	F	Forestry	Single Family Residential
17 107100 RK	R-5	Rural-5 Acre	Single Family Residential
17 105983 RK	R-5	Rural-5 Acre	Single Family Residential
17 111171 RK	R-5	Rural-5 Acre	Single Family Residential
16 110614 000 01 RK	R-9,600	Residential 9,600 sq. ft.	Single Family Residential
17 107810 RK	R-5	Rural-5 Acre	Single Family Residential
17 118328 RK	R-5	Rural-5 Acre	Single Family Residential
17 111533 MH	A-10	Agriculture-10 Acre	Double Wide
17 111332 RK	R-5	Rural-5 Acre	Single Family Residential
17 108445 MH	R-5	Rural-5 Acre	Double Wide
17 101037 RK	R-5	Rural-5 Acre	Single Family Residential

Accessory Dwelling Units

Index # - File Name: 1.0022 - Single Family Dwellings Data\_Snohomish County.pdf

17 106333 RK	F	Forestry	Single Family Residential
17 108594 RK	R-5	Rural-5 Acre	SFR-Basic
16 119277 RK	R-5	Rural-5 Acre	Single Family Residential
17 100380 RK	A-10 : F : R-5	Agriculture-10 Acre : Forestr	Single Family Residential
16 118943 RK	R-5	Rural-5 Acre	SFR-Basic
16 118587 RK	R-5	Rural-5 Acre	SFR-Basic
17 101293 RK	R-5	Rural-5 Acre	SFR-Basic
17 111858 RK	R-5	Rural-5 Acre	Single Family Residential
17 103681 MH	R-5	Rural-5 Acre	Double Wide
17 108229 RK	R-5	Rural-5 Acre	Single Family Residential
16 109434 RK	F	Forestry	Single Family Residential
17 107617 RK	F	Forestry	Duplex
17 100627 RK	F	Forestry	Single Family Residential
16 115531 RK	R-5	Rural-5 Acre	Single Family Residential
16 121829 RK	R-5	Rural-5 Acre	Single Family Residential
17 111966 RK	R-5	Rural-5 Acre	Single Family Residential
17 103804 RK	R-5	Rural-5 Acre	Single Family Residential
17 114721 000 01 RK	R-5	Rural-5 Acre	Single Family Residential
17 105569 MH	F	Forestry	Double Wide
16 115566 RK	R-5	Rural-5 Acre	SFR-Basic
17 111177 MH	R-5	Rural-5 Acre	Double Wide
16 110742 000 01 RK	R-5	Rural-5 Acre	Single Family Residential
16 121417 RK	R-5	Rural-5 Acre	SFR-Basic
17 111175 RK	R-5	Rural-5 Acre	Single Family Residential
17 109060 RK	RRT-10	Rural Resource Transition-10	Single Family Res-Combo
16 105433 RK	R-5	Rural-5 Acre	Single Family Residential
17 112230 RK	R-5	Rural-5 Acre	Single Family Residential
17 112436 RK	R-5	Rural-5 Acre	Single Family Residential
17 105272 RK	R-7,200	Residential 7,200 sq. ft.	Duplex
17 107093 RK	R-5	Rural-5 Acre	Single Family Residential
16 121408 MH	R-5	Rural-5 Acre	Double Wide
16 114970 RK	CITY : R-7,200	City : Residential 7,200 sq. ft	Single Family Residential
17 112100 MH	R-5	Rural-5 Acre	Triple Wide
17 112098 MH	PRD-20,000(M	Residential 20,000 sq. ft. : R-5	MH Park-Double Wide
17 118551 RK	R-7,200	Residential 7,200 sq. ft.	Duplex
16 106398 000 01 RK	R-5	Rural-5 Acre	Single Family Residential
17 109824 RK	A-10	Agriculture-10 Acre	Single Family Residential
17 108596 RK	RRT-10	Rural Resource Transition-10	Single Family Residential
17 109635 RK	R-5	Rural-5 Acre	Single Family Residential
17 105717 RK	R-5	Rural-5 Acre	Single Family Residential
17 100598 RK	R-5	Rural-5 Acre	SFR-Basic
17 103062 RK	R-5	Rural-5 Acre	Single Family Residential
17 104099 RK	R-5	Rural-5 Acre	Single Family Residential
17 102839 RK	R-5	Rural-5 Acre	Single Family Residential
17 108471 RK	R-5	Rural-5 Acre	Single Family Residential
17 102058 RK	R-5	Rural-5 Acre	Single Family Residential
17 115089 RK	F	Forestry	Single Family Residential

Accessory Dwelling Units

Index # - File Name: 1.0022 - Single Family Dwellings Data\_Snohomish County.pdf

17 107319 RK	R-5	Rural-5 Acre	Accessory Apt Detached
17 102169 RK	R-5	Rural-5 Acre	Single Family Residential
17 106693 RK	R-5	Rural-5 Acre	Single Family Residential
17 101919 RK	R-5	Rural-5 Acre	SFR-Basic
17 108436 RK	R-5	Rural-5 Acre	SFR-Basic
17 108438 RK	R-5	Rural-5 Acre	SFR-Basic
17 101918 RK	R-5	Rural-5 Acre	SFR-Basic
17 108435 RK	R-5	Rural-5 Acre	SFR-Basic
17 101922 RK	R-5	Rural-5 Acre	SFR-Basic
17 108432 RK	R-5	Rural-5 Acre	SFR-Basic
17 101923 RK	R-5	Rural-5 Acre	SFR-Basic
17 101924 RK	R-5	Rural-5 Acre	SFR-Basic
17 101921 RK	R-5	Rural-5 Acre	SFR-Basic
17 101920 RK	R-5	Rural-5 Acre	SFR-Basic
17 104024 000 01 RK	R-5	Rural-5 Acre	Single Family Residential
17 101203 000 01 RK	A-10	Agriculture-10 Acre	Single Family Residential
17 102821 RK	R-5	Rural-5 Acre	Single Family Residential
16 118424 RK	RRT-10	Rural Resource Transition-10	Single Family Residential
17 109309 MH	R-5	Rural-5 Acre	Double Wide
17 107447 RK	R-5	Rural-5 Acre	Single Family Residential
17 110775 RK	R-5	Rural-5 Acre	Single Family Residential
17 112742 RK	R-5	Rural-5 Acre	Single Family Residential
16 109869 RK	R-9,600	Residential 9,600 sq. ft.	Single Family Residential
17 110272 RK	R-5	Rural-5 Acre	Single Family Residential
17 112807 RK	R-5	Rural-5 Acre	Single Family Residential
17 109009 RK	R-5	Rural-5 Acre	Single Family Residential
17 101214 RK	R-5	Rural-5 Acre	Single Family Residential
17 101107 RK	R-5	Rural-5 Acre	Single Family Residential
17 109326 RK	R-7,200	Residential 7,200 sq. ft.	Single Family Residential
17 112609 RK	R-8,400	Residential 8,400 sq. ft.	Single Family Residential
17 106545 RK	R-5	Rural-5 Acre	SFR-Basic
16 121089 RK	R-5	Rural-5 Acre	Single Family Residential
16 121084 RK	R-5	Rural-5 Acre	Single Family Residential
17 106544 RK	R-5	Rural-5 Acre	SFR-Basic
16 121086 RK	R-5	Rural-5 Acre	Single Family Residential
17 105408 RK	R-5	Rural-5 Acre	Single Family Residential
16 121090 RK	R-5	Rural-5 Acre	Single Family Residential
17 113673 RK	R-5	Rural-5 Acre	Single Family Residential
17 108274 RK	R-5	Rural-5 Acre	Single Family Residential
16 110988 000 01 RK	R-5	Rural-5 Acre	Single Family Residential
17 105428 RK	R-5	Rural-5 Acre	Single Family Residential
17 102166 RK	R-5	Rural-5 Acre	Single Family Residential
16 111159 RK	R-5	Rural-5 Acre	Single Family Residential
16 121104 RK	R-5	Rural-5 Acre	Single Family Residential
17 100597 RK	R-9,600	Residential 9,600 sq. ft.	Single Family Residential
17 100596 000 01 RK	R-9,600	Residential 9,600 sq. ft.	Single Family Residential
17 105722 RK	R-5	Rural-5 Acre	Single Family Residential

Accessory Dwelling Units

Index # - File Name: 1.0022 - Single Family Dwellings Data\_Snohomish County.pdf

16 121410 MH	R-5	Rural-5 Acre	Double Wide
17 107740 RK	R-5	Rural-5 Acre	Accessory Apt Detached
16 110399 RK	R-5	Rural-5 Acre	SFR-Basic
16 110401 RK	R-5	Rural-5 Acre	Single Family Residential
17 118905 RK	R-7,200	Residential 7,200 sq. ft.	Single Family Residential
17 118562 RK	R-7,200	Residential 7,200 sq. ft.	Single Family Residential
17 118558 RK	R-7,200	Residential 7,200 sq. ft.	Single Family Residential
17 118903 RK	R-7,200	Residential 7,200 sq. ft.	Single Family Residential
17 118560 RK	R-7,200	Residential 7,200 sq. ft.	Single Family Residential
17 118561 RK	R-7,200	Residential 7,200 sq. ft.	Single Family Residential
17 118388 RK	R-7,200	Residential 7,200 sq. ft.	Single Family Residential
17 118390 RK	R-7,200	Residential 7,200 sq. ft.	Single Family Residential
17 117794 RK	R-7,200	Residential 7,200 sq. ft.	Single Family Residential
17 118393 RK	R-7,200	Residential 7,200 sq. ft.	Single Family Residential
17 117782 RK	R-7,200	Residential 7,200 sq. ft.	Single Family Residential
17 118395 RK	R-7,200	Residential 7,200 sq. ft.	Single Family Residential
17 117783 RK	R-7,200	Residential 7,200 sq. ft.	Single Family Residential
17 118391 RK	R-7,200	Residential 7,200 sq. ft.	Single Family Residential
17 117785 RK	R-7,200	Residential 7,200 sq. ft.	Single Family Residential
17 118392 RK	R-7,200	Residential 7,200 sq. ft.	Single Family Residential
17 117788 RK	R-7,200	Residential 7,200 sq. ft.	Single Family Residential
16 110451 RK	LDMR : R-7,20	Low Density Multiple Reside	SFR-Basic
16 110719 RK	R-5	Rural-5 Acre	Single Family Residential
16 110716 RK	R-5	Rural-5 Acre	Single Family Residential
17 109809 RK	R-7,200	Residential 7,200 sq. ft.	Single Family Residential
17 109818 RK	R-7,200	Residential 7,200 sq. ft.	Single Family Residential
17 109804 RK	R-7,200	Residential 7,200 sq. ft.	Single Family Residential
17 111730 RK	R-7,200	Residential 7,200 sq. ft.	Single Family Residential
17 111734 RK	R-7,200	Residential 7,200 sq. ft.	Single Family Residential
17 112080 RK	R-7,200	Residential 7,200 sq. ft.	Single Family Residential
17 111739 RK	R-7,200	Residential 7,200 sq. ft.	Single Family Residential
17 111899 RK	R-7,200	Residential 7,200 sq. ft.	Single Family Residential
17 111735 RK	R-7,200	Residential 7,200 sq. ft.	Single Family Residential
17 111615 RK	R-7,200	Residential 7,200 sq. ft.	Single Family Residential
17 111731 RK	R-7,200	Residential 7,200 sq. ft.	Single Family Residential
17 112076 RK	R-7,200	Residential 7,200 sq. ft.	Single Family Residential
17 112079 RK	R-7,200	Residential 7,200 sq. ft.	Single Family Residential
17 111736 RK	R-7,200	Residential 7,200 sq. ft.	Single Family Residential
17 111898 RK	R-7,200	Residential 7,200 sq. ft.	Single Family Residential
17 112075 RK	R-7,200	Residential 7,200 sq. ft.	Single Family Residential
17 111613 RK	R-7,200	Residential 7,200 sq. ft.	Single Family Residential
17 111732 RK	R-7,200	Residential 7,200 sq. ft.	Single Family Residential
17 111733 RK	R-7,200	Residential 7,200 sq. ft.	Single Family Residential
17 112078 RK	R-7,200	Residential 7,200 sq. ft.	Single Family Residential
17 111895 RK	R-7,200	Residential 7,200 sq. ft.	Single Family Residential
17 111897 RK	R-7,200	Residential 7,200 sq. ft.	Single Family Residential
17 112073 RK	R-7,200	Residential 7,200 sq. ft.	Single Family Residential

Accessory Dwelling Units

Index # - File Name: 1.0022 - Single Family Dwellings Data\_Snohomish County.pdf

17 111614 RK	R-7,200	Residential 7,200 sq. ft.	Single Family Residential
17 111231 RK	R-7,200	Residential 7,200 sq. ft.	Duplex
17 111228 RK	R-7,200	Residential 7,200 sq. ft.	Duplex
17 111233 RK	R-7,200	Residential 7,200 sq. ft.	Duplex
17 111225 RK	R-7,200	Residential 7,200 sq. ft.	Duplex
17 111229 RK	R-7,200	Residential 7,200 sq. ft.	Duplex
17 111206 000 01 RK	R-7,200	Residential 7,200 sq. ft.	Duplex
16 111117 RK	R-5	Rural-5 Acre	SFR-Basic
17 108935 RK	R-7,200	Residential 7,200 sq. ft.	Single Family Residential
17 103070 RK	R-7,200	Residential 7,200 sq. ft.	Single Family Residential
17 103073 RK	R-7,200	Residential 7,200 sq. ft.	Single Family Residential
17 103074 RK	R-7,200	Residential 7,200 sq. ft.	Single Family Residential
17 103071 RK	R-7,200	Residential 7,200 sq. ft.	Single Family Residential
17 103195 RK	R-7,200	Residential 7,200 sq. ft.	Single Family Residential
17 103072 RK	R-7,200	Residential 7,200 sq. ft.	Single Family Residential
17 109814 RK	R-7,200	Residential 7,200 sq. ft.	Single Family Residential
17 103196 RK	R-7,200	Residential 7,200 sq. ft.	Single Family Residential
17 103194 RK	R-7,200	Residential 7,200 sq. ft.	Single Family Residential
17 103199 RK	R-7,200	Residential 7,200 sq. ft.	Single Family Residential
17 103198 RK	R-7,200	Residential 7,200 sq. ft.	Single Family Residential
17 103197 RK	R-7,200	Residential 7,200 sq. ft.	Single Family Residential
17 103419 RK	R-7,200	Residential 7,200 sq. ft.	Single Family Residential
17 109204 RK	R-7,200	Residential 7,200 sq. ft.	Single Family Residential
17 108874 RK	R-7,200	Residential 7,200 sq. ft.	Single Family Residential
17 108855 RK	R-7,200	Residential 7,200 sq. ft.	Single Family Residential
17 108419 RK	R-7,200	Residential 7,200 sq. ft.	Single Family Residential
17 108873 RK	R-7,200	Residential 7,200 sq. ft.	Single Family Residential
17 110894 RK	R-7,200	Residential 7,200 sq. ft.	Single Family Residential
17 108875 RK	R-7,200	Residential 7,200 sq. ft.	Single Family Residential
17 110404 RK	R-7,200	Residential 7,200 sq. ft.	Single Family Residential
17 109202 RK	R-7,200	Residential 7,200 sq. ft.	Single Family Residential
17 109207 RK	R-7,200	Residential 7,200 sq. ft.	Single Family Residential
17 109807 RK	R-7,200	Residential 7,200 sq. ft.	Single Family Residential
17 109387 RK	R-7,200	Residential 7,200 sq. ft.	Single Family Residential
17 109203 RK	R-7,200	Residential 7,200 sq. ft.	Single Family Residential
17 109392 RK	R-7,200	Residential 7,200 sq. ft.	Single Family Residential
17 109815 RK	R-7,200	Residential 7,200 sq. ft.	Single Family Residential
17 109806 RK	R-7,200	Residential 7,200 sq. ft.	Single Family Residential
17 109383 RK	R-7,200	Residential 7,200 sq. ft.	Single Family Residential
17 109812 RK	R-7,200	Residential 7,200 sq. ft.	Single Family Residential
17 109388 RK	R-7,200	Residential 7,200 sq. ft.	Single Family Residential
17 109391 RK	R-7,200	Residential 7,200 sq. ft.	Single Family Residential
17 110405 RK	R-7,200	Residential 7,200 sq. ft.	Single Family Residential
17 111616 RK	R-7,200	Residential 7,200 sq. ft.	Single Family Residential
17 111894 RK	R-7,200	Residential 7,200 sq. ft.	Single Family Residential
17 109212 RK	R-7,200	Residential 7,200 sq. ft.	Single Family Residential
17 105830 RK	R-7,200	Residential 7,200 sq. ft.	Single Family Residential

Accessory Dwelling Units

Index # - File Name: 1.0022 - Single Family Dwellings Data\_Snohomish County.pdf

17 110410 RK	R-7,200	Residential 7,200 sq. ft.	Single Family Residential
17 110417 RK	R-7,200	Residential 7,200 sq. ft.	Single Family Residential
17 109382 RK	R-7,200	Residential 7,200 sq. ft.	Single Family Residential
17 109381 RK	R-7,200	Residential 7,200 sq. ft.	Single Family Residential
17 109209 RK	R-7,200	Residential 7,200 sq. ft.	Single Family Residential
17 108421 RK	R-7,200	Residential 7,200 sq. ft.	Single Family Residential
17 103416 RK	R-7,200	Residential 7,200 sq. ft.	Single Family Residential
17 108270 RK	R-7,200	Residential 7,200 sq. ft.	Single Family Residential
17 103417 RK	R-7,200	Residential 7,200 sq. ft.	Single Family Residential
17 105076 RK	R-7,200	Residential 7,200 sq. ft.	Single Family Residential
17 108952 RK	R-7,200	Residential 7,200 sq. ft.	Single Family Residential
17 109379 RK	R-7,200	Residential 7,200 sq. ft.	Single Family Residential
17 109377 RK	R-7,200	Residential 7,200 sq. ft.	Single Family Residential
17 110415 RK	R-7,200	Residential 7,200 sq. ft.	Single Family Residential
17 110419 RK	R-7,200	Residential 7,200 sq. ft.	Single Family Residential
17 109206 RK	R-7,200	Residential 7,200 sq. ft.	Single Family Residential
17 105077 RK	R-7,200	Residential 7,200 sq. ft.	Single Family Residential
17 107969 RK	R-7,200	Residential 7,200 sq. ft.	Single Family Residential
17 107980 RK	R-7,200	Residential 7,200 sq. ft.	Single Family Residential
17 109817 000 01 RK	R-7,200	Residential 7,200 sq. ft.	Single Family Residential
17 109374 000 01 RK	R-7,200	Residential 7,200 sq. ft.	Single Family Residential
17 110407 000 01 RK	R-7,200	Residential 7,200 sq. ft.	Single Family Residential
17 110403 000 01 RK	R-7,200	Residential 7,200 sq. ft.	Single Family Residential
17 109390 000 01 RK	R-7,200	Residential 7,200 sq. ft.	Single Family Residential
16 110425 RK	LDMR : R-7,20	Low Density Multiple Reside SFR-Basic	
16 110428 RK	LDMR : R-7,20	Low Density Multiple Reside SFR-Basic	
16 110429 RK	LDMR : R-7,20	Low Density Multiple Reside SFR-Basic	
16 110431 RK	LDMR : R-7,20	Low Density Multiple Reside SFR-Basic	
16 110432 RK	LDMR : R-7,20	Low Density Multiple Reside SFR-Basic	
16 110434 RK	LDMR : R-7,20	Low Density Multiple Reside SFR-Basic	
16 110435 RK	LDMR : R-7,20	Low Density Multiple Reside SFR-Basic	
16 110436 RK	LDMR : R-7,20	Low Density Multiple Reside SFR-Basic	
16 110437 RK	LDMR : R-7,20	Low Density Multiple Reside SFR-Basic	
16 110440 RK	LDMR : R-7,20	Low Density Multiple Reside SFR-Basic	
16 110442 RK	LDMR : R-7,20	Low Density Multiple Reside SFR-Basic	
16 110464 RK	LDMR : R-7,20	Low Density Multiple Reside SFR-Basic	
16 110483 RK	LDMR : R-7,20	Low Density Multiple Reside SFR-Basic	
17 111692 000 01 RK	R-5	Rural-5 Acre	Single Family Residential
16 110533 RK	LDMR : R-8,40	Low Density Multiple Reside SFR-Basic	
16 110534 RK	LDMR : R-8,40	Low Density Multiple Reside SFR-Basic	
16 110535 RK	LDMR : R-8,40	Low Density Multiple Reside SFR-Basic	
16 110536 RK	LDMR : R-8,40	Low Density Multiple Reside SFR-Basic	
16 110537 RK	LDMR : R-8,40	Low Density Multiple Reside SFR-Basic	
16 110538 RK	LDMR : R-8,40	Low Density Multiple Reside SFR-Basic	
16 110539 RK	LDMR : R-8,40	Low Density Multiple Reside SFR-Basic	
16 111174 RK	LDMR : R-8,40	Low Density Multiple Reside SFR-Basic	
16 110540 RK	LDMR : R-8,40	Low Density Multiple Reside SFR-Basic	



Accessory Dwelling Units

Index # - File Name: 1.0022 - Single Family Dwellings Data\_Snohomish County.pdf

16 110541 RK	LDMR : R-8,40 Low Density Multiple Reside SFR-Basic		
17 100289 RK	R-5	Rural-5 Acre	Single Family Residential
17 100330 RK	R-7,200(PRD)	Residential 7,200 sq. ft.	Single Family Residential
17 100329 RK	R-7,200(PRD)	Residential 7,200 sq. ft.	Single Family Residential
17 102011 RK	LDMR : PRD-LI Low Density Multiple Reside Single Family Residential		
17 106864 RK	R-5	Rural-5 Acre	Single Family Residential
16 110803 RK	LDMR : PRD-7, Low Density Multiple Reside SFR-Basic		
16 110804 RK	LDMR : PRD-7, Low Density Multiple Reside SFR-Basic		
16 110805 RK	LDMR : PRD-7, Low Density Multiple Reside SFR-Basic		
16 110806 RK	LDMR : PRD-7, Low Density Multiple Reside SFR-Basic		
16 110807 RK	LDMR : PRD-7, Low Density Multiple Reside SFR-Basic		
16 110808 RK	LDMR : PRD-7, Low Density Multiple Reside SFR-Basic		
16 120585 RK	LDMR : PRD-7, Low Density Multiple Reside SFR-Basic		
16 110810 RK	LDMR : PRD-7, Low Density Multiple Reside SFR-Basic		
16 110811 RK	LDMR : PRD-7, Low Density Multiple Reside SFR-Basic		
16 110812 RK	LDMR : PRD-7, Low Density Multiple Reside SFR-Basic		
16 111170 RK	LDMR : PRD-7, Low Density Multiple Reside SFR-Basic		
16 111171 RK	LDMR : PRD-7, Low Density Multiple Reside SFR-Basic		
16 111172 RK	LDMR : PRD-7, Low Density Multiple Reside SFR-Basic		
16 111210 RK	LDMR : PRD-7, Low Density Multiple Reside SFR-Basic		
16 111211 RK	LDMR : PRD-7, Low Density Multiple Reside SFR-Basic		
16 111173 RK	LDMR : PRD-7, Low Density Multiple Reside SFR-Basic		
16 111212 RK	LDMR : PRD-7, Low Density Multiple Reside SFR-Basic		
16 111213 RK	LDMR : PRD-7, Low Density Multiple Reside SFR-Basic		
16 111214 RK	LDMR : PRD-7, Low Density Multiple Reside SFR-Basic		
16 111215 RK	LDMR : PRD-7, Low Density Multiple Reside SFR-Basic		
16 111216 RK	LDMR : PRD-7, Low Density Multiple Reside SFR-Basic		
16 111224 RK	LDMR : PRD-7, Low Density Multiple Reside SFR-Basic		
16 111225 RK	LDMR : PRD-7, Low Density Multiple Reside SFR-Basic		
16 111226 RK	LDMR : PRD-7, Low Density Multiple Reside SFR-Basic		
16 111227 RK	LDMR : PRD-7, Low Density Multiple Reside SFR-Basic		
16 111228 RK	LDMR : PRD-7, Low Density Multiple Reside SFR-Basic		
16 111229 RK	LDMR : PRD-7, Low Density Multiple Reside SFR-Basic		
16 111230 RK	LDMR : PRD-7, Low Density Multiple Reside SFR-Basic		
17 101633 RK	LDMR : PRD-7, Low Density Multiple Reside SFR-Basic		
17 101634 RK	LDMR : PRD-7, Low Density Multiple Reside SFR-Basic		
16 111231 RK	LDMR : PRD-7, Low Density Multiple Reside SFR-Basic		
16 111232 RK	LDMR : PRD-7, Low Density Multiple Reside SFR-Basic		
16 111233 RK	LDMR : PRD-7, Low Density Multiple Reside SFR-Basic		
17 109167 000 01 RK	MR	Multiple Residential	Single Family Residential
17 109171 000 01 RK	MR	Multiple Residential	Single Family Residential
17 110914 000 01 RK	MR	Multiple Residential	Single Family Residential
17 110890 000 01 RK	MR	Multiple Residential	Single Family Residential
17 107456 RK	R-5	Rural-5 Acre	SFR-Basic
17 107465 RK	R-5	Rural-5 Acre	SFR-Basic
17 107470 RK	R-5	Rural-5 Acre	SFR-Basic
17 107452 RK	R-5	Rural-5 Acre	SFR-Basic

Accessory Dwelling Units

Index # - File Name: 1.0022 - Single Family Dwellings Data\_Snohomish County.pdf

16 108196 RK	R-5	Rural-5 Acre	Single Family Residential
16 117345 RK	R-7,200	Residential 7,200 sq. ft.	SFR-Basic
17 100191 RK	R-5	Rural-5 Acre	Single Family Residential
16 117344 RK	R-7,200	Residential 7,200 sq. ft.	SFR-Basic
16 121936 RK	R-7,200	Residential 7,200 sq. ft.	Single Family Residential
16 122014 RK	R-7,200	Residential 7,200 sq. ft.	Single Family Residential
16 122015 RK	R-7,200	Residential 7,200 sq. ft.	Single Family Residential
16 121621 RK	R-7,200	Residential 7,200 sq. ft.	Single Family Residential
16 120661 RK	R-7,200	Residential 7,200 sq. ft.	Single Family Residential
16 115001 RK	R-7,200	Residential 7,200 sq. ft.	Single Family Residential
16 121306 RK	R-7,200	Residential 7,200 sq. ft.	Single Family Residential
16 121934 RK	R-7,200	Residential 7,200 sq. ft.	Single Family Residential
16 121951 RK	R-5	Rural-5 Acre	SFR-Basic
16 118591 RK	R-5	Rural-5 Acre	SFR-Basic
16 120264 RK	R-5	Rural-5 Acre	SFR-Basic
16 121953 RK	R-5	Rural-5 Acre	SFR-Basic
16 118590 RK	R-5	Rural-5 Acre	SFR-Basic
16 118588 RK	R-5	Rural-5 Acre	SFR-Basic
16 118586 RK	R-5	Rural-5 Acre	SFR-Basic
17 118277 RK	R-5	Rural-5 Acre	SFR-Basic
17 100841 RK	R-7,200	Residential 7,200 sq. ft.	Single Family Residential
16 122011 RK	R-7,200	Residential 7,200 sq. ft.	Single Family Residential
16 122081 RK	R-7,200	Residential 7,200 sq. ft.	Single Family Residential
17 100840 RK	R-7,200	Residential 7,200 sq. ft.	Single Family Residential
16 122009 RK	R-7,200	Residential 7,200 sq. ft.	Single Family Residential
17 101186 RK	R-7,200	Residential 7,200 sq. ft.	Single Family Residential
16 121618 RK	R-7,200	Residential 7,200 sq. ft.	Single Family Residential
16 122013 RK	R-7,200	Residential 7,200 sq. ft.	Single Family Residential
16 121620 RK	R-7,200	Residential 7,200 sq. ft.	Single Family Residential
16 121935 RK	R-7,200	Residential 7,200 sq. ft.	Single Family Residential
16 122008 RK	R-7,200	Residential 7,200 sq. ft.	Single Family Residential
16 122079 RK	R-7,200	Residential 7,200 sq. ft.	Single Family Residential
17 100848 RK	R-7,200	Residential 7,200 sq. ft.	Single Family Residential
16 122077 RK	R-7,200	Residential 7,200 sq. ft.	Single Family Residential
16 120652 RK	R-7,200	Residential 7,200 sq. ft.	Single Family Residential
16 121305 RK	R-7,200	Residential 7,200 sq. ft.	Single Family Residential
17 101286 RK	R-7,200 : RC	Residential 7,200 sq. ft. : Ru	SFR-Basic
16 119472 000 01 RK	R-5	Rural-5 Acre	Single Family Residential
16 111033 RK	R-8,400(PRD)	Residential 8,400 sq. ft.	SFR-Basic
16 111034 RK	R-8,400(PRD)	Residential 8,400 sq. ft.	SFR-Basic
16 121409 RK	R-7,200	Residential 7,200 sq. ft.	Single Family Residential
16 121418 RK	R-7,200	Residential 7,200 sq. ft.	Single Family Residential
17 100386 RK	R-8,400(PRD)	Residential 8,400 sq. ft.	Single Family Residential
16 111042 RK	R-8,400(PRD)	Residential 8,400 sq. ft.	SFR-Basic
16 111043 RK	R-8,400(PRD)	Residential 8,400 sq. ft.	SFR-Basic
16 111044 RK	R-8,400(PRD)	Residential 8,400 sq. ft.	SFR-Basic
16 111045 RK	R-8,400(PRD)	Residential 8,400 sq. ft.	SFR-Basic

Accessory Dwelling Units

Index # - File Name: 1.0022 - Single Family Dwellings Data\_Snohomish County.pdf

16 111046 RK	R-8,400(PRD)	Residential 8,400 sq. ft.	SFR-Basic
16 111047 RK	R-8,400(PRD)	Residential 8,400 sq. ft.	SFR-Basic
16 111048 RK	R-8,400(PRD)	Residential 8,400 sq. ft.	SFR-Basic
16 111049 RK	R-8,400(PRD)	Residential 8,400 sq. ft.	SFR-Basic
16 120452 RK	R-8,400(PRD)	Residential 8,400 sq. ft.	SFR-Basic
16 111016 RK	R-8,400(PRD)	Residential 8,400 sq. ft.	SFR-Basic
16 111017 RK	R-8,400(PRD)	Residential 8,400 sq. ft.	SFR-Basic
16 111018 RK	R-8,400(PRD)	Residential 8,400 sq. ft.	SFR-Basic
16 111019 RK	R-8,400(PRD)	Residential 8,400 sq. ft.	SFR-Basic
16 111020 RK	R-8,400(PRD)	Residential 8,400 sq. ft.	SFR-Basic
16 111021 RK	R-8,400(PRD)	Residential 8,400 sq. ft.	SFR-Basic
16 111022 RK	R-8,400(PRD)	Residential 8,400 sq. ft.	SFR-Basic
16 111023 RK	R-8,400(PRD)	Residential 8,400 sq. ft.	SFR-Basic
16 111024 RK	R-8,400(PRD)	Residential 8,400 sq. ft.	SFR-Basic
16 111025 RK	R-8,400(PRD)	Residential 8,400 sq. ft.	SFR-Basic
16 111026 RK	R-8,400(PRD)	Residential 8,400 sq. ft.	SFR-Basic
16 111027 RK	R-8,400(PRD)	Residential 8,400 sq. ft.	SFR-Basic
16 111028 RK	R-8,400(PRD)	Residential 8,400 sq. ft.	SFR-Basic
16 111029 RK	R-8,400(PRD)	Residential 8,400 sq. ft.	SFR-Basic
16 111030 RK	R-8,400(PRD)	Residential 8,400 sq. ft.	SFR-Basic
16 111031 RK	R-8,400(PRD)	Residential 8,400 sq. ft.	SFR-Basic
17 100517 000 01 RK	R-7,200	Residential 7,200 sq. ft.	Single Family Residential
16 111434 000 01 RK	R-7,200	Residential 7,200 sq. ft.	Single Family Residential
16 111426 000 01 RK	R-7,200	Residential 7,200 sq. ft.	Single Family Residential
17 100859 RK	R-9,600	Residential 9,600 sq. ft.	Single Family Residential
17 100861 RK	R-9,600	Residential 9,600 sq. ft.	Single Family Residential
16 121573 RK	R-5	Rural-5 Acre	Single Family Residential
17 108986 RK	R-5	Rural-5 Acre	SFR-Basic
17 101858 RK	R-5	Rural-5 Acre	SFR-Basic
17 108985 RK	R-5	Rural-5 Acre	SFR-Basic
17 108982 RK	R-5	Rural-5 Acre	SFR-Basic
17 101855 RK	R-5	Rural-5 Acre	SFR-Basic
17 101854 RK	R-5	Rural-5 Acre	SFR-Basic
17 108987 RK	R-5	Rural-5 Acre	SFR-Basic
17 101852 RK	R-5	Rural-5 Acre	SFR-Basic
17 101853 RK	R-5	Rural-5 Acre	SFR-Basic
17 101851 RK	R-5	Rural-5 Acre	SFR-Basic
17 108981 RK	R-5	Rural-5 Acre	SFR-Basic
16 118216 RK	R-8,400	Residential 8,400 sq. ft.	Single Family Residential
16 103932 RK	R-5	Rural-5 Acre	Single Family Residential
16 103929 RK	R-5	Rural-5 Acre	Single Family Residential
16 104000 RK	R-5	Rural-5 Acre	Single Family Residential
17 117643 RK	R-5	Rural-5 Acre	Single Family Residential
16 120555 RK	R-9,600	Residential 9,600 sq. ft.	Single Family Residential
17 103179 RK	R-9,600	Residential 9,600 sq. ft.	Single Family Residential
17 116350 RK	R-7,200(PRD)	Residential 7,200 sq. ft.	Single Family Residential
17 116348 RK	R-7,200(PRD)	Residential 7,200 sq. ft.	Single Family Residential

Accessory Dwelling Units

Index # - File Name: 1.0022 - Single Family Dwellings Data\_Snohomish County.pdf

17 116318 RK	R-7,200(PRD)	Residential 7,200 sq. ft.	Single Family Residential
17 116351 RK	R-7,200(PRD)	Residential 7,200 sq. ft.	Single Family Residential
17 116337 RK	R-7,200(PRD)	Residential 7,200 sq. ft.	Single Family Residential
17 116319 RK	R-7,200(PRD)	Residential 7,200 sq. ft.	Single Family Residential
17 115542 RK	R-7,200(PRD)	Residential 7,200 sq. ft.	Single Family Residential
17 117592 RK	R-7,200(PRD)	Residential 7,200 sq. ft.	Single Family Residential
17 116320 RK	R-7,200(PRD)	Residential 7,200 sq. ft.	Single Family Residential
17 116338 RK	R-7,200(PRD)	Residential 7,200 sq. ft.	Single Family Residential
17 116315 RK	R-7,200(PRD)	Residential 7,200 sq. ft.	Single Family Residential
17 116317 RK	R-7,200(PRD)	Residential 7,200 sq. ft.	Single Family Residential
17 116344 RK	R-7,200(PRD)	Residential 7,200 sq. ft.	Single Family Residential
17 116343 RK	R-7,200(PRD)	Residential 7,200 sq. ft.	Single Family Residential
17 116342 RK	R-7,200(PRD)	Residential 7,200 sq. ft.	Single Family Residential
17 116336 RK	R-7,200(PRD)	Residential 7,200 sq. ft.	Single Family Residential
17 116331 RK	R-7,200(PRD)	Residential 7,200 sq. ft.	Single Family Residential
17 116333 RK	R-7,200(PRD)	Residential 7,200 sq. ft.	Single Family Residential
17 116345 RK	R-7,200(PRD)	Residential 7,200 sq. ft.	Single Family Residential
17 116326 RK	R-7,200(PRD)	Residential 7,200 sq. ft.	Single Family Residential
17 116323 RK	R-7,200(PRD)	Residential 7,200 sq. ft.	Single Family Residential
17 116347 RK	R-7,200(PRD)	Residential 7,200 sq. ft.	Single Family Residential
17 115541 RK	R-7,200(PRD)	Residential 7,200 sq. ft.	Single Family Residential
17 115545 RK	R-7,200(PRD)	Residential 7,200 sq. ft.	Single Family Residential
17 115539 RK	R-7,200(PRD)	Residential 7,200 sq. ft.	Single Family Residential
17 103294 RK	R-5	Rural-5 Acre	Single Family Residential
17 103227 RK	R-5	Rural-5 Acre	Single Family Residential
17 112621 RK	R-9,600	Residential 9,600 sq. ft.	Single Family Residential
17 112642 RK	R-9,600	Residential 9,600 sq. ft.	Single Family Residential
17 110795 RK	R-7,200(PRD)	Residential 7,200 sq. ft.	SFR-Basic
17 111293 RK	R-7,200(PRD)	Residential 7,200 sq. ft.	SFR-Basic
17 110797 RK	R-7,200(PRD)	Residential 7,200 sq. ft.	SFR-Basic
17 110829 RK	R-7,200(PRD)	Residential 7,200 sq. ft.	SFR-Basic
17 110830 RK	R-7,200(PRD)	Residential 7,200 sq. ft.	SFR-Basic
17 111288 RK	R-7,200(PRD)	Residential 7,200 sq. ft.	SFR-Basic
17 110832 RK	R-7,200(PRD)	Residential 7,200 sq. ft.	SFR-Basic
17 111289 RK	R-7,200(PRD)	Residential 7,200 sq. ft.	SFR-Basic
17 111313 RK	R-7,200(PRD)	Residential 7,200 sq. ft.	SFR-Basic
17 103722 RK	R-7,200	Residential 7,200 sq. ft.	Single Family Residential
17 104188 RK	R-7,200	Residential 7,200 sq. ft.	Single Family Residential
17 103723 RK	R-7,200	Residential 7,200 sq. ft.	Single Family Residential
17 102715 RK	R-7,200	Residential 7,200 sq. ft.	Single Family Residential
17 101950 RK	R-5	Rural-5 Acre	Duplex
17 110889 RK	MR	Multiple Residential	SFR-Basic
17 110860 RK	MR	Multiple Residential	SFR-Basic
17 110861 RK	MR	Multiple Residential	SFR-Basic
17 110862 RK	MR	Multiple Residential	SFR-Basic
17 110863 RK	MR	Multiple Residential	SFR-Basic
17 110864 RK	MR	Multiple Residential	SFR-Basic

Accessory Dwelling Units

Index # - File Name: 1.0022 - Single Family Dwellings Data\_Snohomish County.pdf

17 110865 RK	MR	Multiple Residential	SFR-Basic
17 110866 RK	MR	Multiple Residential	SFR-Basic
17 110867 RK	MR	Multiple Residential	SFR-Basic
17 110870 RK	MR	Multiple Residential	SFR-Basic
17 110871 RK	MR	Multiple Residential	SFR-Basic
17 112660 RK	MR	Multiple Residential	SFR-Basic
17 112663 RK	MR	Multiple Residential	SFR-Basic
17 110876 RK	MR	Multiple Residential	SFR-Basic
17 110877 RK	MR	Multiple Residential	SFR-Basic
17 112664 RK	MR	Multiple Residential	SFR-Basic
17 110878 RK	MR	Multiple Residential	SFR-Basic
17 110881 RK	MR	Multiple Residential	SFR-Basic
17 112666 RK	MR	Multiple Residential	SFR-Basic
17 110882 RK	MR	Multiple Residential	SFR-Basic
17 110883 RK	MR	Multiple Residential	SFR-Basic
17 113175 RK	MR	Multiple Residential	SFR-Basic
17 110868 RK	MR	Multiple Residential	SFR-Basic
17 110869 RK	MR	Multiple Residential	SFR-Basic
16 120490 RK	MR	Multiple Residential	SFR-Basic
17 101624 MH	R-5	Rural-5 Acre	Single Wide
16 118448 RK	R-5	Rural-5 Acre	Single Family Residential
16 121943 RK	R-5	Rural-5 Acre	Single Family Residential
17 100207 RK	R-5	Rural-5 Acre	SFR-Basic
16 118572 RK	R-5	Rural-5 Acre	SFR-Basic
16 118576 RK	R-5	Rural-5 Acre	SFR-Basic
17 100211 RK	R-5	Rural-5 Acre	SFR-Basic
16 118574 RK	R-5	Rural-5 Acre	SFR-Basic
16 118568 RK	R-5	Rural-5 Acre	SFR-Basic
16 118579 RK	R-5	Rural-5 Acre	SFR-Basic
17 105956 RK	R-7,200(PRD)	Residential 7,200 sq. ft.	SFR-Basic
17 105957 RK	R-7,200(PRD)	Residential 7,200 sq. ft.	SFR-Basic
17 105958 RK	R-7,200(PRD)	Residential 7,200 sq. ft.	SFR-Basic
17 105962 RK	R-7,200(PRD)	Residential 7,200 sq. ft.	SFR-Basic
17 105973 RK	R-7,200(PRD)	Residential 7,200 sq. ft.	SFR-Basic
17 105964 RK	R-7,200(PRD)	Residential 7,200 sq. ft.	SFR-Basic
17 105965 RK	R-7,200(PRD)	Residential 7,200 sq. ft.	SFR-Basic
17 105966 RK	R-7,200(PRD)	Residential 7,200 sq. ft.	SFR-Basic
17 105968 RK	R-7,200(PRD)	Residential 7,200 sq. ft.	SFR-Basic
17 100204 RK	R-5	Rural-5 Acre	SFR-Basic
17 101149 RK	PRD-7,200 : R-	Residential 7,200 sq. ft. : Re:	Single Family Residential
17 101151 RK	PRD-7,200 : R-	Residential 7,200 sq. ft. : Re:	Single Family Residential
17 101283 RK	PRD-7,200 : R-	Residential 7,200 sq. ft. : Re:	Single Family Residential
17 101201 RK	PRD-7,200 : R-	Residential 7,200 sq. ft. : Re:	Single Family Residential
17 111285 RK	R-7,200(PRD)	Residential 7,200 sq. ft.	SFR-Basic
17 111286 RK	R-7,200(PRD)	Residential 7,200 sq. ft.	SFR-Basic
17 111287 RK	R-7,200(PRD)	Residential 7,200 sq. ft.	SFR-Basic
17 111291 RK	R-7,200(PRD)	Residential 7,200 sq. ft.	SFR-Basic

Accessory Dwelling Units

Index # - File Name: 1.0022 - Single Family Dwellings Data\_Snohomish County.pdf

17 110941 RK	R-7,200(PRD)	Residential 7,200 sq. ft.	SFR-Basic
17 111292 RK	R-7,200(PRD)	Residential 7,200 sq. ft.	SFR-Basic
17 110945 RK	R-7,200(PRD)	Residential 7,200 sq. ft.	SFR-Basic
17 110940 RK	R-7,200(PRD)	Residential 7,200 sq. ft.	SFR-Basic
17 110833 RK	R-7,200(PRD)	Residential 7,200 sq. ft.	SFR-Basic
17 110704 RK	R-7,200(PRD)	Residential 7,200 sq. ft.	SFR-Basic
17 110794 RK	R-7,200(PRD)	Residential 7,200 sq. ft.	SFR-Basic
17 111603 RK	LDMR : R-7,20	Low Density Multiple Reside	SFR-Basic
17 107605 RK	LDMR : R-7,20	Low Density Multiple Reside	SFR-Basic
17 107606 RK	LDMR : R-7,20	Low Density Multiple Reside	SFR-Basic
17 107607 RK	LDMR : R-7,20	Low Density Multiple Reside	SFR-Basic
17 108810 RK	LDMR : R-7,20	Low Density Multiple Reside	SFR-Basic
17 108808 RK	LDMR : R-7,20	Low Density Multiple Reside	SFR-Basic
17 109639 RK	LDMR : R-7,20	Low Density Multiple Reside	SFR-Basic
17 109665 RK	LDMR : R-7,20	Low Density Multiple Reside	SFR-Basic
17 109669 RK	LDMR : R-7,20	Low Density Multiple Reside	SFR-Basic
17 111602 RK	LDMR : R-7,20	Low Density Multiple Reside	SFR-Basic
17 111604 RK	LDMR : R-7,20	Low Density Multiple Reside	SFR-Basic
17 111605 RK	LDMR : R-7,20	Low Density Multiple Reside	SFR-Basic
17 111606 RK	LDMR : R-7,20	Low Density Multiple Reside	SFR-Basic
17 110299 RK	LDMR : R-7,20	Low Density Multiple Reside	SFR-Basic
17 108809 RK	LDMR : R-7,20	Low Density Multiple Reside	SFR-Basic
17 108812 RK	LDMR : R-7,20	Low Density Multiple Reside	SFR-Basic
17 103144 RK	LDMR : R-7,20	Low Density Multiple Reside	SFR-Basic
17 111607 RK	LDMR : R-7,20	Low Density Multiple Reside	SFR-Basic
17 102094 RK	R-5	Rural-5 Acre	SFR-Basic
17 109701 RK	R-7,200 : R-8,4	Residential 7,200 sq. ft. : Re:	SFR-Basic
17 109744 RK	R-7,200 : R-8,4	Residential 7,200 sq. ft. : Re:	SFR-Basic
17 109739 RK	R-7,200 : R-8,4	Residential 7,200 sq. ft. : Re:	SFR-Basic
17 109736 RK	R-7,200 : R-8,4	Residential 7,200 sq. ft. : Re:	SFR-Basic
17 109733 RK	R-7,200 : R-8,4	Residential 7,200 sq. ft. : Re:	SFR-Basic
17 109730 RK	R-7,200 : R-8,4	Residential 7,200 sq. ft. : Re:	SFR-Basic
17 107575 RK	R-7,200(PRD)	Residential 7,200 sq. ft.	SFR-Basic
17 107578 RK	R-7,200(PRD)	Residential 7,200 sq. ft.	SFR-Basic
17 107580 RK	R-7,200(PRD)	Residential 7,200 sq. ft.	SFR-Basic
17 107581 RK	R-7,200(PRD)	Residential 7,200 sq. ft.	SFR-Basic
17 106516 RK	R-7,200(PRD)	Residential 7,200 sq. ft.	SFR-Basic
17 106531 RK	R-7,200(PRD)	Residential 7,200 sq. ft.	SFR-Basic
17 106534 RK	R-7,200(PRD)	Residential 7,200 sq. ft.	SFR-Basic
17 106533 RK	R-7,200(PRD)	Residential 7,200 sq. ft.	SFR-Basic
17 106381 RK	R-7,200(PRD)	Residential 7,200 sq. ft.	SFR-Basic
17 106380 RK	R-7,200(PRD)	Residential 7,200 sq. ft.	SFR-Basic
17 106388 RK	R-7,200(PRD)	Residential 7,200 sq. ft.	SFR-Basic
17 104213 RK	R-7,200(PRD)	Residential 7,200 sq. ft.	SFR-Basic
17 104214 RK	R-7,200(PRD)	Residential 7,200 sq. ft.	SFR-Basic
17 104215 RK	R-7,200(PRD)	Residential 7,200 sq. ft.	SFR-Basic
17 104216 RK	R-7,200(PRD)	Residential 7,200 sq. ft.	SFR-Basic

Accessory Dwelling Units

Index # - File Name: 1.0022 - Single Family Dwellings Data\_Snohomish County.pdf

17 104217 RK	R-7,200(PRD)	Residential 7,200 sq. ft.	SFR-Basic
17 103272 RK	R-7,200(PRD)	Residential 7,200 sq. ft.	SFR-Basic
17 103273 RK	R-7,200(PRD)	Residential 7,200 sq. ft.	SFR-Basic
17 103274 RK	R-7,200(PRD)	Residential 7,200 sq. ft.	SFR-Basic
17 103145 RK	R-7,200(PRD)	Residential 7,200 sq. ft.	SFR-Basic
17 103146 RK	R-7,200(PRD)	Residential 7,200 sq. ft.	SFR-Basic
17 104218 RK	R-7,200(PRD)	Residential 7,200 sq. ft.	SFR-Basic
17 107582 RK	R-7,200(PRD)	Residential 7,200 sq. ft.	SFR-Basic
17 107584 RK	R-7,200(PRD)	Residential 7,200 sq. ft.	SFR-Basic
16 120145 RK	CITY : R-5	City : Rural-5 Acre	Duplex-Basic
17 103544 RK	R-7,200 : R-8,4	Residential 7,200 sq. ft. : Res	Single Family Residential
17 103548 RK	R-7,200 : R-8,4	Residential 7,200 sq. ft. : Res	Single Family Residential
17 103549 RK	R-7,200 : R-8,4	Residential 7,200 sq. ft. : Res	Single Family Residential
17 103026 RK	R-5	Rural-5 Acre	Single Family Residential
17 103459 RK	R-5	Rural-5 Acre	Single Family Residential
17 103460 RK	R-5	Rural-5 Acre	Single Family Residential
16 119353 RK	R-5	Rural-5 Acre	SFR-Basic
16 119358 RK	R-5	Rural-5 Acre	SFR-Basic
16 119350 RK	R-5	Rural-5 Acre	SFR-Basic
16 119351 RK	R-5	Rural-5 Acre	SFR-Basic
16 119359 RK	R-5	Rural-5 Acre	SFR-Basic
17 105839 RK	R-5	Rural-5 Acre	Single Family Residential
17 112947 RK	R-5	Rural-5 Acre	Single Family Residential
17 113009 RK	R-5	Rural-5 Acre	Single Family Residential
16 121658 RK	MR	Multiple Residential	SFR-Basic
16 121659 RK	MR	Multiple Residential	SFR-Basic
17 103266 RK	MR	Multiple Residential	SFR-Basic
17 103267 RK	MR	Multiple Residential	SFR-Basic
17 103268 RK	MR	Multiple Residential	SFR-Basic
17 105801 RK	MR	Multiple Residential	SFR-Basic
17 105928 RK	MR	Multiple Residential	SFR-Basic
17 107338 RK	MR	Multiple Residential	SFR-Basic
17 107339 RK	MR	Multiple Residential	SFR-Basic
17 107530 RK	MR	Multiple Residential	SFR-Basic
17 108144 RK	MR	Multiple Residential	SFR-Basic
17 108142 RK	MR	Multiple Residential	SFR-Basic
17 108143 RK	MR	Multiple Residential	SFR-Basic
17 108892 RK	MR	Multiple Residential	SFR-Basic
17 108893 RK	MR	Multiple Residential	SFR-Basic
17 108896 RK	MR	Multiple Residential	SFR-Basic
17 108900 RK	MR	Multiple Residential	SFR-Basic
17 108898 RK	MR	Multiple Residential	SFR-Basic
17 108899 RK	MR	Multiple Residential	SFR-Basic
17 109534 RK	MR	Multiple Residential	SFR-Basic
17 109535 RK	MR	Multiple Residential	SFR-Basic
17 109536 RK	MR	Multiple Residential	SFR-Basic
17 110822 RK	MR	Multiple Residential	SFR-Basic

Accessory Dwelling Units

Index # - File Name: 1.0022 - Single Family Dwellings Data\_Snohomish County.pdf

17 110823 RK	MR	Multiple Residential	SFR-Basic
17 110824 RK	MR	Multiple Residential	SFR-Basic
17 111554 RK	MR	Multiple Residential	SFR-Basic
17 111553 RK	MR	Multiple Residential	SFR-Basic
17 111557 RK	MR	Multiple Residential	SFR-Basic
17 111555 RK	MR	Multiple Residential	SFR-Basic
17 100444 RK	MR	Multiple Residential	SFR-Basic
16 121660 RK	MR	Multiple Residential	SFR-Basic
17 103269 RK	MR	Multiple Residential	SFR-Basic
17 105929 RK	MR	Multiple Residential	SFR-Basic
17 105930 RK	MR	Multiple Residential	SFR-Basic
17 107304 RK	MR	Multiple Residential	SFR-Basic
17 107306 RK	MR	Multiple Residential	SFR-Basic
17 107531 RK	MR	Multiple Residential	SFR-Basic
17 108145 RK	MR	Multiple Residential	SFR-Basic
17 108146 RK	MR	Multiple Residential	SFR-Basic
17 108148 RK	MR	Multiple Residential	SFR-Basic
17 109542 RK	MR	Multiple Residential	SFR-Basic
17 109543 RK	MR	Multiple Residential	SFR-Basic
17 109537 RK	MR	Multiple Residential	SFR-Basic
17 110826 RK	MR	Multiple Residential	SFR-Basic
17 110827 RK	MR	Multiple Residential	SFR-Basic
17 110821 RK	MR	Multiple Residential	SFR-Basic
17 111556 RK	MR	Multiple Residential	SFR-Basic
17 111568 RK	MR	Multiple Residential	SFR-Basic
17 111558 RK	MR	Multiple Residential	SFR-Basic
17 108429 RK	R-5	Rural-5 Acre	SFR-Basic
17 105443 RK	R-5	Rural-5 Acre	SFR-Basic
17 105445 RK	R-5	Rural-5 Acre	SFR-Basic
17 107063 RK	R-5	Rural-5 Acre	SFR-Basic
17 105446 RK	R-5	Rural-5 Acre	SFR-Basic
17 107058 RK	R-5	Rural-5 Acre	SFR-Basic
17 108253 RK	R-5	Rural-5 Acre	SFR-Basic
17 108193 RK	R-5	Rural-5 Acre	SFR-Basic
17 107066 RK	R-5	Rural-5 Acre	SFR-Basic
17 105449 RK	R-5	Rural-5 Acre	SFR-Basic
17 105444 RK	R-5	Rural-5 Acre	SFR-Basic
17 100774 RK	BP : LDMR : PF Business Park : Low Density		SFR-Basic
17 100775 RK	BP : LDMR : PF Business Park : Low Density		SFR-Basic
17 100776 RK	BP : LDMR : PF Business Park : Low Density		SFR-Basic
17 100777 RK	BP : LDMR : PF Business Park : Low Density		SFR-Basic
17 100778 RK	BP : LDMR : PF Business Park : Low Density		SFR-Basic
17 100779 RK	BP : LDMR : PF Business Park : Low Density		SFR-Basic
17 100780 RK	BP : LDMR : PF Business Park : Low Density		SFR-Basic
17 100781 RK	BP : LDMR : PF Business Park : Low Density		SFR-Basic
17 100782 RK	BP : LDMR : PF Business Park : Low Density		SFR-Basic
17 100783 RK	BP : LDMR : PF Business Park : Low Density		SFR-Basic



Accessory Dwelling Units

Index # - File Name: 1.0022 - Single Family Dwellings Data\_Snohomish County.pdf

17 100784 RK	BP : LDMR : PF Business Park : Low Density	SFR-Basic
17 100785 RK	BP : LDMR : PF Business Park : Low Density	SFR-Basic
17 100786 RK	BP : LDMR : PF Business Park : Low Density	SFR-Basic
17 100787 RK	BP : LDMR : PF Business Park : Low Density	SFR-Basic
16 121046 RK	R-5 Rural-5 Acre	Duplex-Basic
16 121322 RK	MR Multiple Residential	Single Family Residential
16 121326 RK	MR Multiple Residential	Single Family Residential
16 121327 RK	MR Multiple Residential	Single Family Residential
16 121328 RK	MR Multiple Residential	Single Family Residential
17 105950 RK	R-7,200(PRD) Residential 7,200 sq. ft.	SFR-Basic
17 105954 RK	R-7,200(PRD) Residential 7,200 sq. ft.	SFR-Basic
17 105944 RK	R-7,200(PRD) Residential 7,200 sq. ft.	SFR-Basic
17 105949 RK	R-7,200(PRD) Residential 7,200 sq. ft.	SFR-Basic
17 105951 RK	R-7,200(PRD) Residential 7,200 sq. ft.	SFR-Basic
17 105959 RK	R-7,200(PRD) Residential 7,200 sq. ft.	SFR-Basic
17 105955 RK	R-7,200(PRD) Residential 7,200 sq. ft.	SFR-Basic
17 101139 RK	R-5 Rural-5 Acre	Single Family Residential
17 103436 RK	R-5 Rural-5 Acre	Single Family Residential
17 105402 RK	R-5 Rural-5 Acre	Single Family Residential
17 101865 RK	R-5 Rural-5 Acre	Single Family Residential
17 108028 RK	R-5 Rural-5 Acre	Single Family Residential
17 106548 RK	R-5 Rural-5 Acre	Single Family Residential
17 101864 RK	R-5 Rural-5 Acre	Single Family Residential
17 101526 RK	LDMR : R-7,20 Low Density Multiple Reside	SFR-Basic
17 101527 RK	LDMR : R-7,20 Low Density Multiple Reside	SFR-Basic
17 101528 RK	LDMR : R-7,20 Low Density Multiple Reside	SFR-Basic
17 101529 RK	LDMR : R-7,20 Low Density Multiple Reside	SFR-Basic
17 101530 RK	LDMR : R-7,20 Low Density Multiple Reside	SFR-Basic
17 101531 RK	LDMR : R-7,20 Low Density Multiple Reside	SFR-Basic
17 101532 RK	LDMR : R-7,20 Low Density Multiple Reside	SFR-Basic
17 101533 RK	LDMR : R-7,20 Low Density Multiple Reside	SFR-Basic
17 101534 RK	LDMR : R-7,20 Low Density Multiple Reside	SFR-Basic
17 101535 RK	LDMR : R-7,20 Low Density Multiple Reside	SFR-Basic
17 101536 RK	LDMR : R-7,20 Low Density Multiple Reside	SFR-Basic
17 101537 RK	LDMR : R-7,20 Low Density Multiple Reside	SFR-Basic
17 101538 RK	LDMR : R-7,20 Low Density Multiple Reside	SFR-Basic
17 101539 RK	LDMR : R-7,20 Low Density Multiple Reside	SFR-Basic
17 101540 RK	LDMR : R-7,20 Low Density Multiple Reside	SFR-Basic
17 101541 RK	LDMR : R-7,20 Low Density Multiple Reside	SFR-Basic
17 101542 RK	LDMR : R-7,20 Low Density Multiple Reside	SFR-Basic
17 101001 RK	LDMR : R-7,20 Low Density Multiple Reside	SFR-Basic
17 101002 RK	LDMR : R-7,20 Low Density Multiple Reside	SFR-Basic
17 101003 RK	LDMR : R-7,20 Low Density Multiple Reside	SFR-Basic
17 101004 RK	LDMR : R-7,20 Low Density Multiple Reside	SFR-Basic
17 101005 RK	LDMR : R-7,20 Low Density Multiple Reside	SFR-Basic
17 101006 RK	LDMR : R-7,20 Low Density Multiple Reside	SFR-Basic
17 101007 RK	LDMR : R-7,20 Low Density Multiple Reside	SFR-Basic

Accessory Dwelling Units

Index # - File Name: 1.0022 - Single Family Dwellings Data\_Snohomish County.pdf

17 101008 RK	LDMR : R-7,20	Low Density Multiple Reside	SFR-Basic
17 101010 RK	LDMR : R-7,20	Low Density Multiple Reside	SFR-Basic
16 121852 RK	R-5	Rural-5 Acre	SFR-Basic
16 121849 RK	R-5	Rural-5 Acre	SFR-Basic
16 121854 000 01 RK	R-5	Rural-5 Acre	SFR-Basic
17 107104 RK	R-5	Rural-5 Acre	Single Family Residential
17 100823 000 01 RK	R-5	Rural-5 Acre	Single Family Residential
17 100833 RK	R-5	Rural-5 Acre	Single Family Residential
16 121767 RK	MR	Multiple Residential	SFR-Basic
16 121768 RK	MR	Multiple Residential	SFR-Basic
16 121769 RK	MR	Multiple Residential	SFR-Basic
17 100886 RK	MR	Multiple Residential	SFR-Basic
17 100878 RK	MR	Multiple Residential	SFR-Basic
17 101174 RK	MR	Multiple Residential	SFR-Basic
17 101175 RK	MR	Multiple Residential	SFR-Basic
17 101176 RK	MR	Multiple Residential	SFR-Basic
17 112474 RK	MR	Multiple Residential	SFR-Basic
17 112416 RK	MR	Multiple Residential	SFR-Basic
17 112418 RK	MR	Multiple Residential	SFR-Basic
17 112417 RK	MR	Multiple Residential	SFR-Basic
17 112432 RK	MR	Multiple Residential	SFR-Basic
17 112421 RK	MR	Multiple Residential	SFR-Basic
17 112422 RK	MR	Multiple Residential	SFR-Basic
17 112433 RK	MR	Multiple Residential	SFR-Basic
17 112438 RK	MR	Multiple Residential	SFR-Basic
17 112434 RK	MR	Multiple Residential	SFR-Basic
17 112430 RK	MR	Multiple Residential	SFR-Basic
17 112437 RK	MR	Multiple Residential	SFR-Basic
17 112431 RK	MR	Multiple Residential	SFR-Basic
17 100883 RK	MR	Multiple Residential	SFR-Basic
17 100884 RK	MR	Multiple Residential	SFR-Basic
17 101564 RK	MR	Multiple Residential	SFR-Basic
17 101565 RK	MR	Multiple Residential	SFR-Basic
17 101566 RK	MR	Multiple Residential	SFR-Basic
17 101567 RK	MR	Multiple Residential	SFR-Basic
17 101568 RK	MR	Multiple Residential	SFR-Basic
17 101569 RK	MR	Multiple Residential	SFR-Basic
17 110551 RK	MR	Multiple Residential	SFR-Basic
17 110547 RK	MR	Multiple Residential	SFR-Basic
17 110550 RK	MR	Multiple Residential	SFR-Basic
17 110549 RK	MR	Multiple Residential	SFR-Basic
17 110548 RK	MR	Multiple Residential	SFR-Basic
17 110546 RK	MR	Multiple Residential	SFR-Basic
17 101570 RK	MR	Multiple Residential	SFR-Basic
17 101571 RK	MR	Multiple Residential	SFR-Basic
17 101572 RK	MR	Multiple Residential	SFR-Basic
17 101573 RK	MR	Multiple Residential	SFR-Basic

Accessory Dwelling Units

Index # - File Name: 1.0022 - Single Family Dwellings Data\_Snohomish County.pdf

17 101574 RK	MR	Multiple Residential	SFR-Basic
17 101575 RK	MR	Multiple Residential	SFR-Basic
17 101576 RK	MR	Multiple Residential	SFR-Basic
16 118581 RK	R-8,400	Residential 8,400 sq. ft.	Single Family Residential
17 103154 RK	R-5	Rural-5 Acre	SFR-Basic
17 105108 RK	R-7,200	Residential 7,200 sq. ft.	SFR-Basic
17 105115 RK	R-7,200	Residential 7,200 sq. ft.	SFR-Basic
17 105116 RK	R-7,200	Residential 7,200 sq. ft.	SFR-Basic
17 102124 RK	R-7,200	Residential 7,200 sq. ft.	SFR-Basic
17 105921 RK	R-7,200	Residential 7,200 sq. ft.	SFR-Basic
17 105918 RK	R-7,200	Residential 7,200 sq. ft.	SFR-Basic
17 105919 RK	R-7,200	Residential 7,200 sq. ft.	SFR-Basic
17 108887 RK	R-7,200	Residential 7,200 sq. ft.	SFR-Basic
17 108889 RK	R-7,200	Residential 7,200 sq. ft.	SFR-Basic
17 108888 RK	R-7,200	Residential 7,200 sq. ft.	SFR-Basic
17 106792 RK	R-7,200	Residential 7,200 sq. ft.	SFR-Basic
17 106805 RK	R-7,200	Residential 7,200 sq. ft.	SFR-Basic
17 106800 RK	R-7,200	Residential 7,200 sq. ft.	SFR-Basic
17 106801 RK	R-7,200	Residential 7,200 sq. ft.	SFR-Basic
17 109355 RK	R-7,200	Residential 7,200 sq. ft.	SFR-Basic
17 109356 RK	R-7,200	Residential 7,200 sq. ft.	SFR-Basic
17 109357 RK	R-7,200	Residential 7,200 sq. ft.	SFR-Basic
17 109360 RK	R-7,200	Residential 7,200 sq. ft.	SFR-Basic
17 103128 RK	R-7,200	Residential 7,200 sq. ft.	SFR-Basic
17 101397 RK	R-7,200	Residential 7,200 sq. ft.	SFR-Basic
17 102125 RK	R-7,200	Residential 7,200 sq. ft.	SFR-Basic
17 102126 RK	R-7,200	Residential 7,200 sq. ft.	SFR-Basic
17 102127 RK	R-7,200	Residential 7,200 sq. ft.	SFR-Basic
17 102128 RK	R-7,200	Residential 7,200 sq. ft.	SFR-Basic
17 108353 RK	R-7,200	Residential 7,200 sq. ft.	SFR-Basic
17 108355 RK	R-7,200	Residential 7,200 sq. ft.	SFR-Basic
17 108356 RK	R-7,200	Residential 7,200 sq. ft.	SFR-Basic
17 102129 RK	R-7,200	Residential 7,200 sq. ft.	SFR-Basic
17 102130 RK	R-7,200	Residential 7,200 sq. ft.	SFR-Basic
17 102131 RK	R-7,200	Residential 7,200 sq. ft.	SFR-Basic
17 102132 RK	R-7,200	Residential 7,200 sq. ft.	SFR-Basic
17 107277 RK	R-7,200	Residential 7,200 sq. ft.	SFR-Basic
17 107538 RK	R-7,200	Residential 7,200 sq. ft.	SFR-Basic
17 107877 RK	R-7,200	Residential 7,200 sq. ft.	SFR-Basic
17 103986 RK	R-7,200	Residential 7,200 sq. ft.	SFR-Basic
17 103982 RK	R-7,200	Residential 7,200 sq. ft.	SFR-Basic
17 103983 RK	R-7,200	Residential 7,200 sq. ft.	SFR-Basic
17 103984 RK	R-7,200	Residential 7,200 sq. ft.	SFR-Basic
17 107875 RK	R-7,200	Residential 7,200 sq. ft.	SFR-Basic
17 107935 RK	R-7,200	Residential 7,200 sq. ft.	SFR-Basic
17 108040 RK	R-7,200	Residential 7,200 sq. ft.	SFR-Basic
17 109671 RK	R-7,200	Residential 7,200 sq. ft.	SFR-Basic

Accessory Dwelling Units

Index # - File Name: 1.0022 - Single Family Dwellings Data\_Snohomish County.pdf

17 109717 RK	R-7,200	Residential 7,200 sq. ft.	SFR-Basic
17 109683 RK	R-7,200	Residential 7,200 sq. ft.	SFR-Basic
17 109672 RK	R-7,200	Residential 7,200 sq. ft.	SFR-Basic
17 109681 RK	R-7,200	Residential 7,200 sq. ft.	SFR-Basic
17 109696 RK	R-7,200 : R-8,4	Residential 7,200 sq. ft. : Re	SFR-Basic
17 109707 RK	R-7,200 : R-8,4	Residential 7,200 sq. ft. : Re	SFR-Basic
17 109711 RK	R-7,200 : R-8,4	Residential 7,200 sq. ft. : Re	SFR-Basic
17 109714 RK	R-7,200 : R-8,4	Residential 7,200 sq. ft. : Re	SFR-Basic
17 109715 RK	R-7,200 : R-8,4	Residential 7,200 sq. ft. : Re	SFR-Basic
17 109697 RK	R-7,200 : R-8,4	Residential 7,200 sq. ft. : Re	SFR-Basic
17 109705 RK	R-7,200 : R-8,4	Residential 7,200 sq. ft. : Re	SFR-Basic
17 109708 RK	R-7,200 : R-8,4	Residential 7,200 sq. ft. : Re	SFR-Basic
17 109716 RK	R-7,200 : R-8,4	Residential 7,200 sq. ft. : Re	SFR-Basic
17 109738 RK	R-7,200 : R-8,4	Residential 7,200 sq. ft. : Re	SFR-Basic
17 110893 RK	LDMR	Low Density Multiple Reside	SFR-Basic
17 115184 RK	LDMR	Low Density Multiple Reside	SFR-Basic
17 115144 RK	LDMR	Low Density Multiple Reside	SFR-Basic
17 113214 RK	LDMR	Low Density Multiple Reside	SFR-Basic
17 110891 RK	LDMR	Low Density Multiple Reside	SFR-Basic
17 112384 RK	LDMR	Low Density Multiple Reside	SFR-Basic
17 110887 RK	LDMR	Low Density Multiple Reside	SFR-Basic
17 112385 RK	LDMR	Low Density Multiple Reside	SFR-Basic
17 110892 RK	LDMR	Low Density Multiple Reside	SFR-Basic
17 112386 RK	LDMR	Low Density Multiple Reside	SFR-Basic
17 110895 RK	LDMR	Low Density Multiple Reside	SFR-Basic
17 112387 RK	LDMR	Low Density Multiple Reside	SFR-Basic
17 110896 RK	LDMR	Low Density Multiple Reside	SFR-Basic
17 112389 RK	LDMR	Low Density Multiple Reside	SFR-Basic
17 110884 RK	LDMR	Low Density Multiple Reside	SFR-Basic
17 110888 RK	LDMR	Low Density Multiple Reside	SFR-Basic
17 110885 RK	LDMR	Low Density Multiple Reside	SFR-Basic
17 109472 RK	LDMR	Low Density Multiple Reside	SFR-Basic
17 114952 RK	LDMR	Low Density Multiple Reside	SFR-Basic
17 109468 RK	LDMR	Low Density Multiple Reside	SFR-Basic
17 114950 RK	LDMR	Low Density Multiple Reside	SFR-Basic
17 109469 RK	LDMR	Low Density Multiple Reside	SFR-Basic
17 114953 RK	LDMR	Low Density Multiple Reside	SFR-Basic
17 109470 RK	LDMR	Low Density Multiple Reside	SFR-Basic
17 114961 RK	LDMR	Low Density Multiple Reside	SFR-Basic
17 109473 RK	LDMR	Low Density Multiple Reside	SFR-Basic
17 118172 RK	R-5	Rural-5 Acre	Single Family Residential
17 105296 RK	LDMR : R-9,60	Low Density Multiple Reside	SFR-Basic
17 105284 RK	LDMR : R-9,60	Low Density Multiple Reside	SFR-Basic
17 105287 RK	LDMR : R-9,60	Low Density Multiple Reside	SFR-Basic
17 105297 RK	LDMR : R-9,60	Low Density Multiple Reside	SFR-Basic
17 105288 RK	LDMR : R-9,60	Low Density Multiple Reside	SFR-Basic
17 105289 RK	LDMR : R-9,60	Low Density Multiple Reside	SFR-Basic

Accessory Dwelling Units

Index # - File Name: 1.0022 - Single Family Dwellings Data\_Snohomish County.pdf

17 105290 RK	LDMR : R-9,60 Low Density Multiple Reside SFR-Basic		
17 105291 RK	LDMR : R-9,60 Low Density Multiple Reside SFR-Basic		
17 105292 RK	LDMR : R-9,60 Low Density Multiple Reside SFR-Basic		
17 105294 RK	LDMR : R-9,60 Low Density Multiple Reside SFR-Basic		
17 105298 RK	LDMR : R-9,60 Low Density Multiple Reside SFR-Basic		
17 105299 RK	LDMR : R-9,60 Low Density Multiple Reside SFR-Basic		
17 105301 RK	LDMR : R-9,60 Low Density Multiple Reside SFR-Basic		
17 105302 RK	LDMR : R-9,60 Low Density Multiple Reside SFR-Basic		
17 105303 RK	LDMR : R-9,60 Low Density Multiple Reside SFR-Basic		
17 105357 RK	LDMR : R-9,60 Low Density Multiple Reside SFR-Basic		
17 105358 RK	LDMR : R-9,60 Low Density Multiple Reside SFR-Basic		
17 105295 RK	LDMR : R-9,60 Low Density Multiple Reside SFR-Basic		
17 105360 RK	LDMR : R-9,60 Low Density Multiple Reside SFR-Basic		
17 105361 RK	LDMR : R-9,60 Low Density Multiple Reside SFR-Basic		
17 105362 RK	LDMR : R-9,60 Low Density Multiple Reside SFR-Basic		
17 101275 RK	R-9,600	Residential 9,600 sq. ft.	SFR-Basic
17 101276 RK	R-9,600	Residential 9,600 sq. ft.	SFR-Basic
17 101277 RK	R-9,600	Residential 9,600 sq. ft.	SFR-Basic
17 101278 RK	R-9,600	Residential 9,600 sq. ft.	SFR-Basic
17 101498 RK	R-9,600	Residential 9,600 sq. ft.	SFR-Basic
17 101499 RK	R-9,600	Residential 9,600 sq. ft.	SFR-Basic
17 101500 RK	R-9,600	Residential 9,600 sq. ft.	SFR-Basic
17 101501 RK	R-9,600	Residential 9,600 sq. ft.	SFR-Basic
17 101502 RK	R-9,600	Residential 9,600 sq. ft.	SFR-Basic
17 101577 RK	R-9,600	Residential 9,600 sq. ft.	SFR-Basic
17 101578 RK	R-9,600	Residential 9,600 sq. ft.	SFR-Basic
17 101579 RK	R-9,600	Residential 9,600 sq. ft.	SFR-Basic
17 101580 RK	R-9,600	Residential 9,600 sq. ft.	SFR-Basic
17 101581 RK	R-9,600	Residential 9,600 sq. ft.	SFR-Basic
17 101582 RK	R-9,600	Residential 9,600 sq. ft.	SFR-Basic
17 101583 RK	R-9,600	Residential 9,600 sq. ft.	SFR-Basic
17 101584 RK	R-9,600	Residential 9,600 sq. ft.	SFR-Basic
17 101279 RK	R-9,600	Residential 9,600 sq. ft.	SFR-Basic
17 101503 RK	R-9,600	Residential 9,600 sq. ft.	SFR-Basic
17 102708 RK	R-7,200 : R-9,6 Residential 7,200 sq. ft. : Re: Single Family Residential		
17 102710 RK	R-7,200 : R-9,6 Residential 7,200 sq. ft. : Re: Single Family Residential		
17 102712 RK	R-7,200 : R-9,6 Residential 7,200 sq. ft. : Re: Single Family Residential		
17 105187 RK	R-7,200 : R-9,6 Residential 7,200 sq. ft. : Re: Single Family Residential		
17 104190 RK	R-7,200 : R-9,6 Residential 7,200 sq. ft. : Re: Single Family Residential		
17 106015 RK	R-7,200 : R-9,6 Residential 7,200 sq. ft. : Re: Single Family Residential		
17 105185 RK	R-7,200 : R-9,6 Residential 7,200 sq. ft. : Re: Single Family Residential		
17 102707 RK	R-7,200 : R-9,6 Residential 7,200 sq. ft. : Re: Single Family Residential		
16 120147 RK	R-5	Rural-5 Acre	Accessory Apt Detached
17 100474 RK	R-5	Rural-5 Acre	Single Family Residential
16 117856 MH	R-5	Rural-5 Acre	Double Wide
17 110510 RK	R-7,200(PRD)	Residential 7,200 sq. ft.	SFR-Basic
17 108577 RK	R-7,200(PRD)	Residential 7,200 sq. ft.	SFR-Basic

Accessory Dwelling Units

Index # - File Name: 1.0022 - Single Family Dwellings Data\_Snohomish County.pdf

17 106581 RK	R-7,200(PRD)	Residential 7,200 sq. ft.	Single Family Residential
17 109091 RK	R-7,200(PRD)	Residential 7,200 sq. ft.	SFR-Basic
17 106807 RK	R-7,200(PRD)	Residential 7,200 sq. ft.	SFR-Basic
17 106796 RK	R-7,200(PRD)	Residential 7,200 sq. ft.	SFR-Basic
17 110736 RK	R-7,200(PRD)	Residential 7,200 sq. ft.	Single Family Residential
17 116559 RK	R-7,200(PRD)	Residential 7,200 sq. ft.	SFR-Basic
17 116698 RK	R-7,200(PRD)	Residential 7,200 sq. ft.	Single Family Residential
17 116700 RK	R-7,200(PRD)	Residential 7,200 sq. ft.	Single Family Residential
17 106795 RK	R-7,200(PRD)	Residential 7,200 sq. ft.	SFR-Basic
17 106582 RK	R-7,200(PRD)	Residential 7,200 sq. ft.	Single Family Residential
17 106822 RK	R-7,200(PRD)	Residential 7,200 sq. ft.	SFR-Basic
17 106580 RK	R-7,200(PRD)	Residential 7,200 sq. ft.	Single Family Residential
17 113193 RK	R-7,200(PRD)	Residential 7,200 sq. ft.	SFR-Basic
17 111772 RK	R-7,200(PRD)	Residential 7,200 sq. ft.	SFR-Basic
17 112375 RK	R-7,200(PRD)	Residential 7,200 sq. ft.	SFR-Basic
17 110737 RK	R-7,200(PRD)	Residential 7,200 sq. ft.	Single Family Residential
17 110738 RK	R-7,200(PRD)	Residential 7,200 sq. ft.	Single Family Residential
17 111207 RK	R-7,200(PRD)	Residential 7,200 sq. ft.	Single Family Residential
17 108354 RK	R-7,200(PRD)	Residential 7,200 sq. ft.	Single Family Residential
17 107603 RK	R-7,200(PRD)	Residential 7,200 sq. ft.	Single Family Residential
17 112725 RK	R-7,200(PRD)	Residential 7,200 sq. ft.	SFR-Basic
17 107609 RK	R-7,200(PRD)	Residential 7,200 sq. ft.	Single Family Residential
17 106802 RK	R-7,200(PRD)	Residential 7,200 sq. ft.	SFR-Basic
17 107610 RK	R-7,200(PRD)	Residential 7,200 sq. ft.	Single Family Residential
17 108361 RK	R-7,200(PRD)	Residential 7,200 sq. ft.	Single Family Residential
17 111153 RK	R-7,200(PRD)	Residential 7,200 sq. ft.	SFR-Basic
17 111211 RK	R-7,200(PRD)	Residential 7,200 sq. ft.	Single Family Residential
17 109093 RK	R-7,200(PRD)	Residential 7,200 sq. ft.	SFR-Basic
17 113483 RK	R-7,200(PRD)	Residential 7,200 sq. ft.	SFR-Basic
17 113494 RK	R-7,200(PRD)	Residential 7,200 sq. ft.	SFR-Basic
17 113485 RK	R-7,200(PRD)	Residential 7,200 sq. ft.	SFR-Basic
17 115102 RK	R-7,200(PRD)	Residential 7,200 sq. ft.	SFR-Basic
17 115553 RK	R-7,200(PRD)	Residential 7,200 sq. ft.	SFR-Basic
17 106578 RK	R-7,200(PRD)	Residential 7,200 sq. ft.	Single Family Residential
17 106797 RK	R-7,200(PRD)	Residential 7,200 sq. ft.	SFR-Basic
17 106574 RK	R-7,200(PRD)	Residential 7,200 sq. ft.	Single Family Residential
17 106575 RK	R-7,200(PRD)	Residential 7,200 sq. ft.	Single Family Residential
17 106573 RK	R-7,200(PRD)	Residential 7,200 sq. ft.	Single Family Residential
17 106821 RK	R-7,200(PRD)	Residential 7,200 sq. ft.	SFR-Basic
17 108362 RK	R-7,200(PRD)	Residential 7,200 sq. ft.	Single Family Residential
17 109078 RK	R-7,200(PRD)	Residential 7,200 sq. ft.	Single Family Residential
17 106799 RK	R-7,200(PRD)	Residential 7,200 sq. ft.	SFR-Basic
17 106577 RK	R-7,200(PRD)	Residential 7,200 sq. ft.	Single Family Residential
17 106651 RK	R-7,200(PRD)	Residential 7,200 sq. ft.	Single Family Residential
17 106654 RK	R-7,200(PRD)	Residential 7,200 sq. ft.	Single Family Residential
17 106803 RK	R-7,200(PRD)	Residential 7,200 sq. ft.	SFR-Basic
17 106804 RK	R-7,200(PRD)	Residential 7,200 sq. ft.	SFR-Basic

Accessory Dwelling Units

Index # - File Name: 1.0022 - Single Family Dwellings Data\_Snohomish County.pdf

17 106653 RK	R-7,200(PRD)	Residential 7,200 sq. ft.	Single Family Residential
17 106655 RK	R-7,200(PRD)	Residential 7,200 sq. ft.	Single Family Residential
17 105177 RK	R-9,600	Residential 9,600 sq. ft.	SFR-Basic
17 105178 RK	R-9,600	Residential 9,600 sq. ft.	SFR-Basic
17 101630 RK	R-9,600	Residential 9,600 sq. ft.	SFR-Basic
16 121784 RK	R-7,200	Residential 7,200 sq. ft.	SFR-Basic
16 121785 RK	R-7,200	Residential 7,200 sq. ft.	SFR-Basic
16 121786 RK	R-7,200	Residential 7,200 sq. ft.	SFR-Basic
16 121787 RK	R-7,200	Residential 7,200 sq. ft.	SFR-Basic
16 110596 RK	R-5	Rural-5 Acre	SFR-Basic
16 110603 RK	R-5	Rural-5 Acre	SFR-Basic
16 121780 RK	R-7,200	Residential 7,200 sq. ft.	SFR-Basic
16 121781 RK	R-7,200	Residential 7,200 sq. ft.	SFR-Basic
17 102931 RK	R-5	Rural-5 Acre	Single Family Residential
17 105744 RK	R-5	Rural-5 Acre	Single Family Residential
17 112537 RK	R-5	Rural-5 Acre	Single Family Residential
16 121653 RK	R-9,600	Residential 9,600 sq. ft.	Single Family Residential
16 121654 RK	R-9,600	Residential 9,600 sq. ft.	Single Family Residential
16 121651 RK	R-9,600	Residential 9,600 sq. ft.	Single Family Residential
17 101439 RK	R-5	Rural-5 Acre	Single Family Residential
17 101468 RK	R-9,600	Residential 9,600 sq. ft.	SFR-Basic
17 101457 RK	R-9,600	Residential 9,600 sq. ft.	SFR-Basic
17 101458 RK	R-9,600	Residential 9,600 sq. ft.	SFR-Basic
17 101459 RK	R-9,600	Residential 9,600 sq. ft.	SFR-Basic
17 101460 RK	R-9,600	Residential 9,600 sq. ft.	SFR-Basic
17 101461 RK	R-9,600	Residential 9,600 sq. ft.	SFR-Basic
17 101462 RK	R-9,600	Residential 9,600 sq. ft.	SFR-Basic
17 101463 RK	R-9,600	Residential 9,600 sq. ft.	SFR-Basic
17 101464 RK	R-9,600	Residential 9,600 sq. ft.	SFR-Basic
17 101465 RK	R-9,600	Residential 9,600 sq. ft.	SFR-Basic
17 101466 RK	R-9,600	Residential 9,600 sq. ft.	SFR-Basic
17 100903 RK	R-9,600	Residential 9,600 sq. ft.	SFR-Basic
17 101585 RK	R-9,600	Residential 9,600 sq. ft.	SFR-Basic
17 100676 RK	R-7,200	Residential 7,200 sq. ft.	SFR-Basic
17 100677 RK	R-7,200	Residential 7,200 sq. ft.	SFR-Basic
17 100678 RK	R-7,200	Residential 7,200 sq. ft.	SFR-Basic
17 100679 RK	R-7,200	Residential 7,200 sq. ft.	SFR-Basic
17 100680 RK	R-7,200	Residential 7,200 sq. ft.	SFR-Basic
17 100681 RK	R-7,200	Residential 7,200 sq. ft.	SFR-Basic
17 100682 RK	R-7,200	Residential 7,200 sq. ft.	SFR-Basic
16 116899 RK	R-5	Rural-5 Acre	Single Family Residential
16 121874 RK	R-9,600	Residential 9,600 sq. ft.	SFR-Basic
16 121875 RK	R-9,600	Residential 9,600 sq. ft.	SFR-Basic
17 101631 RK	R-9,600	Residential 9,600 sq. ft.	SFR-Basic
16 121876 RK	R-9,600	Residential 9,600 sq. ft.	SFR-Basic
16 121877 RK	R-9,600	Residential 9,600 sq. ft.	SFR-Basic
16 117844 RK	R-5	Rural-5 Acre	Single Family Residential

Accessory Dwelling Units

Index # - File Name: 1.0022 - Single Family Dwellings Data\_Snohomish County.pdf

16 118835 RK	R-5	Rural-5 Acre	Single Family Residential
16 113288 RK	R-5	Rural-5 Acre	Single Family Residential
16 118584 RK	R-5	Rural-5 Acre	SFR-Basic
16 121818 RK	R-7,200	Residential 7,200 sq. ft.	SFR-Basic
16 121817 RK	R-7,200	Residential 7,200 sq. ft.	SFR-Basic
16 121815 RK	R-7,200	Residential 7,200 sq. ft.	SFR-Basic
17 107792 RK	R-7,200	Residential 7,200 sq. ft.	Single Family Residential
16 119013 RK	R-5	Rural-5 Acre	SFR-Basic
17 107077 RK	R-20,000	Residential 20,000 sq. ft.	Single Family Residential
16 121763 RK	R-7,200	Residential 7,200 sq. ft.	Single Family Residential
17 108818 RK	R-9,600	Residential 9,600 sq. ft.	Single Family Residential
16 110765 RK	R-5	Rural-5 Acre	Single Family Residential
16 110775 RK	R-5	Rural-5 Acre	SFR-Basic
16 110776 RK	R-5	Rural-5 Acre	SFR-Basic
16 110766 RK	R-5	Rural-5 Acre	SFR-Basic
16 110772 RK	R-5	Rural-5 Acre	SFR-Basic
16 110769 RK	R-5	Rural-5 Acre	SFR-Basic
16 110771 RK	R-5	Rural-5 Acre	SFR-Basic
16 110767 RK	R-5	Rural-5 Acre	SFR-Basic
17 100847 RK	R-5	Rural-5 Acre	Single Family Residential
17 106694 RK	R-5	Rural-5 Acre	Single Family Residential
17 100845 RK	R-5	Rural-5 Acre	Single Family Residential
17 109602 RK	R-5	Rural-5 Acre	Single Family Residential
17 103676 RK	R-5	Rural-5 Acre	Single Family Residential
17 111138 RK	R-5	Rural-5 Acre	SFR-Basic
17 111922 RK	R-5	Rural-5 Acre	SFR-Basic
17 111144 RK	R-5	Rural-5 Acre	SFR-Basic
17 111940 RK	R-5	Rural-5 Acre	SFR-Basic
16 110270 RK	R-5	Rural-5 Acre	SFR-Basic
16 109293 RK	R-5	Rural-5 Acre	SFR-Basic
17 103987 RK	R-5	Rural-5 Acre	SFR-Basic
17 103926 RK	R-5	Rural-5 Acre	SFR-Basic
17 100454 RK	R-5	Rural-5 Acre	SFR-Basic
16 119493 RK	R-5	Rural-5 Acre	SFR-Basic
17 112577 RK	R-5	Rural-5 Acre	Single Family Residential
17 101115 RK	R-5	Rural-5 Acre	SFR-Basic
17 117385 RK	R-5	Rural-5 Acre	Single Family Residential
17 106951 MH	R-5	Rural-5 Acre	Double Wide
17 104048 RK	R-7,200	Residential 7,200 sq. ft.	Single Family Residential
17 104046 RK	R-7,200	Residential 7,200 sq. ft.	Single Family Residential
17 103556 RK	R-9,600	Residential 9,600 sq. ft.	Single Family Residential
17 101287 RK	R-9,600	Residential 9,600 sq. ft.	Single Family Residential
17 106814 RK	R-5	Rural-5 Acre	SFR-Basic
17 106914 RK	R-5	Rural-5 Acre	SFR-Basic
17 106815 RK	R-5	Rural-5 Acre	SFR-Basic
17 114879 RK	R-5	Rural-5 Acre	SFR-Basic
17 107032 RK	R-5	Rural-5 Acre	SFR-Basic



Accessory Dwelling Units

Index # - File Name: 1.0022 - Single Family Dwellings Data\_Snohomish County.pdf

16 110872 RK	R-5	Rural-5 Acre	SFR-Basic
17 106705 RK	R-9,600	Residential 9,600 sq. ft.	Single Family Residential
17 108918 RK	R-9,600	Residential 9,600 sq. ft.	Single Family Residential
17 101609 RK	R-9,600	Residential 9,600 sq. ft.	SFR-Basic
17 105401 RK	R-9,600	Residential 9,600 sq. ft.	Single Family Residential
17 103936 RK	R-9,600	Residential 9,600 sq. ft.	Single Family Residential
17 102176 RK	R-9,600	Residential 9,600 sq. ft.	Single Family Residential
17 103935 RK	R-9,600	Residential 9,600 sq. ft.	Single Family Residential
17 103933 RK	R-9,600	Residential 9,600 sq. ft.	Single Family Residential
17 103978 RK	R-9,600	Residential 9,600 sq. ft.	Single Family Residential
17 103938 RK	R-9,600	Residential 9,600 sq. ft.	Single Family Residential
17 103937 RK	R-9,600	Residential 9,600 sq. ft.	Single Family Residential
17 103934 RK	R-9,600	Residential 9,600 sq. ft.	Single Family Residential
17 103974 RK	R-9,600	Residential 9,600 sq. ft.	Single Family Residential
17 106375 RK	R-9,600	Residential 9,600 sq. ft.	Single Family Residential
17 106704 RK	R-9,600	Residential 9,600 sq. ft.	Single Family Residential
17 105545 RK	R-9,600	Residential 9,600 sq. ft.	Single Family Residential
17 105407 RK	R-9,600	Residential 9,600 sq. ft.	Single Family Residential
17 106910 RK	R-5	Rural-5 Acre	SFR-Basic
16 121429 RK	R-9,600	Residential 9,600 sq. ft.	SFR-Basic
16 121422 RK	R-9,600	Residential 9,600 sq. ft.	SFR-Basic
16 121428 RK	R-9,600	Residential 9,600 sq. ft.	SFR-Basic
16 121427 RK	R-9,600	Residential 9,600 sq. ft.	SFR-Basic
17 100856 RK	R-9,600	Residential 9,600 sq. ft.	SFR-Basic
17 100851 RK	R-9,600	Residential 9,600 sq. ft.	SFR-Basic
17 101611 RK	R-9,600	Residential 9,600 sq. ft.	SFR-Basic
17 111166 RK	R-5	Rural-5 Acre	SFR-Basic
17 112338 RK	R-5	Rural-5 Acre	SFR-Basic
17 114972 RK	R-5	Rural-5 Acre	SFR-Basic
17 107070 RK	R-5	Rural-5 Acre	SFR-Basic
17 111928 RK	R-5	Rural-5 Acre	SFR-Basic
16 121134 RK	R-5	Rural-5 Acre	SFR-Basic
16 110880 RK	R-5	Rural-5 Acre	SFR-Basic
17 103280 RK	R-5	Rural-5 Acre	SFR-Basic
17 109856 RK	R-5	Rural-5 Acre	Single Family Residential
17 107741 RK	R-5	Rural-5 Acre	SFR-Basic
17 111165 RK	R-5	Rural-5 Acre	SFR-Basic
16 120290 RK	R-5	Rural-5 Acre	SFR-Basic
17 111386 RK	R-5	Rural-5 Acre	SFR-Basic
17 109260 RK	R-5	Rural-5 Acre	SFR-Basic
17 112857 RK	R-5	Rural-5 Acre	SFR-Basic
17 111385 RK	R-5	Rural-5 Acre	SFR-Basic
17 106733 RK	R-5	Rural-5 Acre	SFR-Basic
17 103973 RK	R-5	Rural-5 Acre	SFR-Basic
17 108377 RK	R-5	Rural-5 Acre	Single Family Residential
17 115952 RK	R-9,600	Residential 9,600 sq. ft.	Single Family Residential
17 110384 RK	R-9,600	Residential 9,600 sq. ft.	Single Family Residential

Accessory Dwelling Units

Index # - File Name: 1.0022 - Single Family Dwellings Data\_Snohomish County.pdf

17 117324 RK	R-9,600	Residential 9,600 sq. ft.	Single Family Residential
17 108922 RK	R-9,600	Residential 9,600 sq. ft.	Single Family Residential
17 106708 RK	R-9,600	Residential 9,600 sq. ft.	Single Family Residential
17 106374 RK	R-9,600	Residential 9,600 sq. ft.	Single Family Residential
16 120207 RK	R-9,600	Residential 9,600 sq. ft.	Single Family Residential
17 100855 RK	R-9,600	Residential 9,600 sq. ft.	SFR-Basic
16 121948 RK	R-9,600	Residential 9,600 sq. ft.	Single Family Residential
16 121952 RK	R-9,600	Residential 9,600 sq. ft.	Single Family Residential
17 100788 RK	R-9,600	Residential 9,600 sq. ft.	Single Family Residential
17 103927 RK	R-9,600	Residential 9,600 sq. ft.	Single Family Residential
17 102171 RK	R-9,600	Residential 9,600 sq. ft.	Single Family Residential
17 105403 RK	R-9,600	Residential 9,600 sq. ft.	Single Family Residential
17 108485 RK	R-9,600	Residential 9,600 sq. ft.	Single Family Residential
17 102154 RK	R-5	Rural-5 Acre	SFR-Basic
17 102150 RK	R-5	Rural-5 Acre	SFR-Basic
17 116999 RK	R-9,600	Residential 9,600 sq. ft.	Single Family Residential
16 121954 RK	R-9,600	Residential 9,600 sq. ft.	Single Family Residential
17 105405 RK	R-9,600	Residential 9,600 sq. ft.	Single Family Residential
17 102179 RK	R-9,600	Residential 9,600 sq. ft.	Single Family Residential
17 100244 RK	R-9,600	Residential 9,600 sq. ft.	Single Family Residential
16 120467 RK	R-9,600	Residential 9,600 sq. ft.	Single Family Residential
17 103930 RK	R-9,600	Residential 9,600 sq. ft.	Single Family Residential
17 103362 RK	R-9,600	Residential 9,600 sq. ft.	Single Family Residential
17 102172 RK	R-9,600	Residential 9,600 sq. ft.	Single Family Residential
17 115960 RK	R-9,600	Residential 9,600 sq. ft.	Single Family Residential
17 107474 RK	R-9,600	Residential 9,600 sq. ft.	Single Family Residential
17 103929 RK	R-9,600	Residential 9,600 sq. ft.	Single Family Residential
16 120469 RK	R-9,600	Residential 9,600 sq. ft.	Single Family Residential
16 121258 RK	R-9,600	Residential 9,600 sq. ft.	Single Family Residential
17 118310 RK	R-9,600	Residential 9,600 sq. ft.	Single Family Residential
17 116704 RK	R-9,600	Residential 9,600 sq. ft.	Single Family Residential
17 106710 RK	R-9,600	Residential 9,600 sq. ft.	Single Family Residential
17 113150 RK	R-9,600	Residential 9,600 sq. ft.	Single Family Residential
17 108220 RK	R-7,200	Residential 7,200 sq. ft.	Single Family Residential
16 118676 RK	R-5	Rural-5 Acre	Single Family Residential
16 121837 RK	R-5	Rural-5 Acre	SFR-Basic
17 108122 RK	R-5	Rural-5 Acre	Single Family Residential
16 118368 RK	LDMR : PRD-7, Low Density Multiple Reside SFR-Basic		
16 118369 RK	LDMR : PRD-7, Low Density Multiple Reside SFR-Basic		
16 118370 RK	LDMR : PRD-7, Low Density Multiple Reside SFR-Basic		
17 100799 RK	LDMR : PRD-7, Low Density Multiple Reside SFR-Basic		
16 118372 RK	LDMR : PRD-7, Low Density Multiple Reside SFR-Basic		
17 107327 RK	R-5	Rural-5 Acre	Single Family Residential
17 111158 RK	R-5	Rural-5 Acre	Single Family Residential
17 105963 RK	R-5	Rural-5 Acre	Accessory Apt Detached
17 107431 RK	R-5	Rural-5 Acre	Single Family Residential
17 106419 000 01 RK	A-10	Agriculture-10 Acre	Single Family Residential

Accessory Dwelling Units

Index # - File Name: 1.0022 - Single Family Dwellings Data\_Snohomish County.pdf

17 101295 RK	R-5	Rural-5 Acre	SFR-Basic
17 113194 RK	R-5	Rural-5 Acre	Single Family Residential
16 103922 000 01 RK	R-5	Rural-5 Acre	Single Family Residential
17 102112 RK	R-5	Rural-5 Acre	Single Family Residential
17 111937 RK	R-5	Rural-5 Acre	Single Family Residential
16 121896 RK	MR	Multiple Residential	Duplex
17 105580 RK	R-5	Rural-5 Acre	Single Family Residential
17 103180 RK	R-5	Rural-5 Acre	SFR-Basic
17 106225 RK	R-5	Rural-5 Acre	Single Family Residential
17 106230 RK	R-5	Rural-5 Acre	Single Family Residential
17 109584 RK	R-5	Rural-5 Acre	Single Family Residential
17 109587 RK	R-5	Rural-5 Acre	Single Family Residential
17 101932 RK	R-5	Rural-5 Acre	SFR-Basic
16 103456 RK	R-5	Rural-5 Acre	SFR-Basic
17 111519 RK	R-5	Rural-5 Acre	Single Family Residential
17 111521 RK	R-5	Rural-5 Acre	Single Family Residential
17 108853 RK	R-5	Rural-5 Acre	Single Family Residential
17 103030 RK	R-5	Rural-5 Acre	Single Family Residential
17 103806 RK	RRT-10	Rural Resource Transition-10	Single Family Residential
16 121827 RK	R-5	Rural-5 Acre	Single Family Residential
17 105250 RK	R-5	Rural-5 Acre	SFR-Basic
17 103708 RK	R-5	Rural-5 Acre	Single Family Residential
17 112115 RK	R-5	Rural-5 Acre	Single Family Residential
17 105628 RK	R-5	Rural-5 Acre	Single Family Residential
17 105633 RK	R-5	Rural-5 Acre	Single Family Residential
16 111139 RK	R-5	Rural-5 Acre	Single Family Residential
17 105521 RK	R-5	Rural-5 Acre	Single Family Residential
17 118660 MH	R-5	Rural-5 Acre	Double Wide
17 103382 RK	R-5	Rural-5 Acre	Single Family Residential
17 110771 RK	R-5	Rural-5 Acre	Single Family Residential
16 110705 RK	R-5	Rural-5 Acre	Single Family Residential
16 110048 RK	R-5	Rural-5 Acre	Single Family Residential
16 110715 RK	R-5	Rural-5 Acre	Single Family Residential
16 110045 RK	R-5	Rural-5 Acre	Single Family Residential
17 113531 RK	MR : PRD-7,20	Multiple Residential : Reside	SFR-Basic
17 114497 RK	MR : PRD-7,20	Multiple Residential : Reside	SFR-Basic
17 113533 RK	MR : PRD-7,20	Multiple Residential : Reside	SFR-Basic
17 113539 RK	MR : PRD-7,20	Multiple Residential : Reside	SFR-Basic
17 113538 RK	MR : PRD-7,20	Multiple Residential : Reside	SFR-Basic
17 118489 RK	R-7,200(PRD)	Residential 7,200 sq. ft.	SFR-Basic
17 118490 RK	R-7,200(PRD)	Residential 7,200 sq. ft.	SFR-Basic
17 118491 RK	R-7,200(PRD)	Residential 7,200 sq. ft.	SFR-Basic
17 118492 RK	R-7,200(PRD)	Residential 7,200 sq. ft.	SFR-Basic
17 118493 RK	R-7,200(PRD)	Residential 7,200 sq. ft.	SFR-Basic
17 118494 RK	R-7,200(PRD)	Residential 7,200 sq. ft.	SFR-Basic
17 118495 RK	R-7,200(PRD)	Residential 7,200 sq. ft.	SFR-Basic
17 111862 RK	R-5	Rural-5 Acre	Single Family Residential

Accessory Dwelling Units

Index # - File Name: 1.0022 - Single Family Dwellings Data\_Snohomish County.pdf

17 115700 RK	R-5	Rural-5 Acre	Single Family Residential
17 116873 RK	R-5	Rural-5 Acre	Single Family Residential
17 115366 RK	R-5	Rural-5 Acre	SFR-Basic
17 115694 RK	R-5	Rural-5 Acre	SFR-Basic
17 115716 RK	R-5	Rural-5 Acre	SFR-Basic
17 115367 RK	R-5	Rural-5 Acre	SFR-Basic
17 115715 RK	R-5	Rural-5 Acre	SFR-Basic
17 115718 RK	R-5	Rural-5 Acre	SFR-Basic
17 115368 RK	R-5	Rural-5 Acre	SFR-Basic
17 115717 RK	R-5	Rural-5 Acre	SFR-Basic
17 115721 RK	R-5	Rural-5 Acre	SFR-Basic
17 116953 RK	R-7,200	Residential 7,200 sq. ft.	SFR-Basic
17 116955 RK	R-7,200	Residential 7,200 sq. ft.	SFR-Basic
17 116954 RK	R-7,200	Residential 7,200 sq. ft.	SFR-Basic
17 116956 RK	R-7,200	Residential 7,200 sq. ft.	SFR-Basic
17 116872 RK	R-7,200	Residential 7,200 sq. ft.	SFR-Basic
17 116893 RK	R-7,200	Residential 7,200 sq. ft.	SFR-Basic
17 116892 RK	R-7,200	Residential 7,200 sq. ft.	SFR-Basic
17 116870 RK	R-7,200	Residential 7,200 sq. ft.	SFR-Basic
17 116869 RK	R-7,200	Residential 7,200 sq. ft.	SFR-Basic
17 116830 RK	R-7,200	Residential 7,200 sq. ft.	SFR-Basic
17 116829 RK	R-7,200	Residential 7,200 sq. ft.	SFR-Basic
17 116587 RK	R-5	Rural-5 Acre	Single Family Residential
17 116658 RK	R-5	Rural-5 Acre	Single Family Residential
17 116593 RK	R-5	Rural-5 Acre	Single Family Residential
17 116596 RK	R-5	Rural-5 Acre	Single Family Residential
17 116600 RK	R-5	Rural-5 Acre	Single Family Residential
17 116601 RK	R-5	Rural-5 Acre	Single Family Residential
17 113490 RK	R-5	Rural-5 Acre	Single Family Residential
17 109670 000 01 RK	F	Forestry	Single Family Residential
17 114971 RK	R-7,200(PRD)	Residential 7,200 sq. ft.	SFR-Basic
17 114973 RK	R-7,200(PRD)	Residential 7,200 sq. ft.	SFR-Basic
17 114968 RK	R-7,200(PRD)	Residential 7,200 sq. ft.	SFR-Basic
17 106294 RK	R-5	Rural-5 Acre	Single Family Residential
17 112067 RK	R-5	Rural-5 Acre	Single Family Residential
17 100362 MH	R-5	Rural-5 Acre	Double Wide
17 111807 RK	R-5	Rural-5 Acre	Single Family Residential
17 111804 RK	R-5	Rural-5 Acre	Single Family Residential
17 117185 RK	R-7,200	Residential 7,200 sq. ft.	Single Family Residential
17 107957 RK	R-5	Rural-5 Acre	Single Family Residential
17 117184 RK	R-7,200	Residential 7,200 sq. ft.	Single Family Residential
17 119251 RK	R-7,200(PRD)	Residential 7,200 sq. ft.	SFR-Basic
17 119029 RK	R-7,200(PRD)	Residential 7,200 sq. ft.	SFR-Basic
17 116835 RK	R-7,200(PRD)	Residential 7,200 sq. ft.	SFR-Basic
17 116468 RK	R-7,200(PRD)	Residential 7,200 sq. ft.	SFR-Basic
17 116696 RK	R-7,200(PRD)	Residential 7,200 sq. ft.	SFR-Basic
17 117183 RK	R-7,200	Residential 7,200 sq. ft.	Single Family Residential

Accessory Dwelling Units

Index # - File Name: 1.0022 - Single Family Dwellings Data\_Snohomish County.pdf

17 116008 RK	R-7,200(PRD)	Residential 7,200 sq. ft.	SFR-Basic
17 116007 RK	R-7,200(PRD)	Residential 7,200 sq. ft.	SFR-Basic
17 119027 RK	R-7,200(PRD)	Residential 7,200 sq. ft.	SFR-Basic
17 119705 RK	R-7,200(PRD)	Residential 7,200 sq. ft.	SFR-Basic
17 119706 RK	R-7,200(PRD)	Residential 7,200 sq. ft.	SFR-Basic
17 114487 RK	R-7,200(PRD)	Residential 7,200 sq. ft.	SFR-Basic
17 114500 RK	R-7,200(PRD)	Residential 7,200 sq. ft.	SFR-Basic
17 114501 RK	R-7,200(PRD)	Residential 7,200 sq. ft.	SFR-Basic
17 114502 RK	R-7,200(PRD)	Residential 7,200 sq. ft.	SFR-Basic
17 116469 RK	R-7,200(PRD)	Residential 7,200 sq. ft.	SFR-Basic
17 116832 RK	R-7,200(PRD)	Residential 7,200 sq. ft.	SFR-Basic
17 119028 RK	R-7,200(PRD)	Residential 7,200 sq. ft.	SFR-Basic
17 119253 RK	R-7,200(PRD)	Residential 7,200 sq. ft.	SFR-Basic
17 108404 RK	LDMR : R-7,20	Low Density Multiple Reside	Single Family Residential
17 104075 RK	R-5	Rural-5 Acre	Single Family Residential
17 110588 RK	R-7,200	Residential 7,200 sq. ft.	SFR-Basic
17 110589 RK	R-7,200	Residential 7,200 sq. ft.	SFR-Basic
17 110590 RK	R-7,200	Residential 7,200 sq. ft.	SFR-Basic
17 110592 RK	R-7,200	Residential 7,200 sq. ft.	SFR-Basic
17 110900 RK	R-7,200	Residential 7,200 sq. ft.	SFR-Basic
17 110907 RK	R-7,200	Residential 7,200 sq. ft.	SFR-Basic
17 111150 RK	R-7,200	Residential 7,200 sq. ft.	SFR-Basic
17 111151 RK	R-7,200	Residential 7,200 sq. ft.	SFR-Basic
17 111552 RK	R-7,200	Residential 7,200 sq. ft.	SFR-Basic
17 111925 RK	R-7,200	Residential 7,200 sq. ft.	SFR-Basic
17 111551 RK	R-7,200	Residential 7,200 sq. ft.	SFR-Basic
17 111924 RK	R-7,200	Residential 7,200 sq. ft.	SFR-Basic
17 111926 RK	R-7,200	Residential 7,200 sq. ft.	SFR-Basic
17 113063 RK	R-7,200(PRD)	Residential 7,200 sq. ft.	SFR-Basic
17 113530 RK	R-7,200(PRD)	Residential 7,200 sq. ft.	SFR-Basic
17 113540 RK	R-7,200(PRD)	Residential 7,200 sq. ft.	SFR-Basic
17 114863 RK	R-7,200(PRD)	Residential 7,200 sq. ft.	SFR-Basic
17 114891 RK	R-7,200(PRD)	Residential 7,200 sq. ft.	SFR-Basic
17 114902 RK	R-7,200(PRD)	Residential 7,200 sq. ft.	SFR-Basic
17 114913 RK	R-7,200(PRD)	Residential 7,200 sq. ft.	SFR-Basic
17 114920 RK	R-7,200(PRD)	Residential 7,200 sq. ft.	SFR-Basic
17 114894 RK	R-7,200(PRD)	Residential 7,200 sq. ft.	SFR-Basic
17 114893 RK	R-7,200(PRD)	Residential 7,200 sq. ft.	SFR-Basic
17 114904 RK	R-7,200(PRD)	Residential 7,200 sq. ft.	SFR-Basic
17 114903 RK	R-7,200(PRD)	Residential 7,200 sq. ft.	SFR-Basic
17 114909 RK	R-7,200(PRD)	Residential 7,200 sq. ft.	SFR-Basic
17 114907 RK	R-7,200(PRD)	Residential 7,200 sq. ft.	SFR-Basic
17 113027 RK	R-7,200(PRD)	Residential 7,200 sq. ft.	SFR-Basic
17 113551 RK	R-7,200(PRD)	Residential 7,200 sq. ft.	SFR-Basic
17 113064 RK	R-7,200(PRD)	Residential 7,200 sq. ft.	SFR-Basic
17 114921 RK	R-7,200(PRD)	Residential 7,200 sq. ft.	SFR-Basic
17 114918 RK	R-7,200(PRD)	Residential 7,200 sq. ft.	SFR-Basic

Accessory Dwelling Units

Index # - File Name: 1.0022 - Single Family Dwellings Data\_Snohomish County.pdf

17 114937 RK	R-7,200(PRD)	Residential 7,200 sq. ft.	SFR-Basic
17 114939 RK	R-7,200(PRD)	Residential 7,200 sq. ft.	SFR-Basic
17 113550 RK	R-7,200(PRD)	Residential 7,200 sq. ft.	SFR-Basic
17 113548 RK	R-7,200(PRD)	Residential 7,200 sq. ft.	SFR-Basic
17 114946 RK	R-7,200(PRD)	Residential 7,200 sq. ft.	SFR-Basic
17 114970 RK	R-7,200(PRD)	Residential 7,200 sq. ft.	SFR-Basic
17 114866 RK	R-7,200(PRD)	Residential 7,200 sq. ft.	SFR-Basic
17 105435 RK	R-5	Rural-5 Acre	SFR-Basic
17 105452 RK	R-5	Rural-5 Acre	SFR-Basic
17 105456 RK	R-5	Rural-5 Acre	SFR-Basic
17 108157 RK	R-5	Rural-5 Acre	SFR-Basic
17 105454 RK	R-5	Rural-5 Acre	SFR-Basic
17 106832 RK	R-5	Rural-5 Acre	SFR-Basic
17 105457 RK	R-5	Rural-5 Acre	SFR-Basic
17 105458 RK	R-5	Rural-5 Acre	SFR-Basic
17 105459 RK	R-5	Rural-5 Acre	SFR-Basic
17 105453 RK	R-5	Rural-5 Acre	SFR-Basic
17 105455 RK	R-5	Rural-5 Acre	SFR-Basic
17 105460 RK	R-5	Rural-5 Acre	SFR-Basic
17 106823 RK	R-5	Rural-5 Acre	SFR-Basic
17 112091 RK	R-7,200 : R-9,€	Residential 7,200 sq. ft. : Re: Single Family Residential	
17 112092 RK	R-7,200 : R-9,€	Residential 7,200 sq. ft. : Re: Single Family Residential	
17 115854 RK	R-7,200 : R-9,€	Residential 7,200 sq. ft. : Re: Single Family Residential	
17 115857 RK	R-7,200 : R-9,€	Residential 7,200 sq. ft. : Re: Single Family Residential	
17 105707 RK	R-5	Rural-5 Acre	Single Family Residential
17 108100 RK	R-5	Rural-5 Acre	Single Family Residential
17 109428 RK	R-5	Rural-5 Acre	Single Family Residential
17 117255 RK	MHP : MR	Mobile Home Park : Multiple	Single Family Residential
17 117249 RK	MHP : MR	Mobile Home Park : Multiple	Single Family Residential
17 116476 RK	MHP : MR	Mobile Home Park : Multiple	Single Family Residential
17 117250 RK	MHP : MR	Mobile Home Park : Multiple	Single Family Residential
17 117256 RK	MHP : MR	Mobile Home Park : Multiple	Single Family Residential
17 117257 RK	MHP : MR	Mobile Home Park : Multiple	Single Family Residential
17 116480 RK	MHP : MR	Mobile Home Park : Multiple	Single Family Residential
17 117258 RK	MHP : MR	Mobile Home Park : Multiple	Single Family Residential
17 117252 RK	MHP : MR	Mobile Home Park : Multiple	Single Family Residential
17 116536 RK	MHP : MR	Mobile Home Park : Multiple	Single Family Residential
17 116552 RK	MHP : MR	Mobile Home Park : Multiple	Single Family Residential
17 116545 RK	MR	Multiple Residential	Single Family Residential
17 117253 RK	MHP : MR	Mobile Home Park : Multiple	Single Family Residential
17 116544 RK	MHP : MR	Mobile Home Park : Multiple	Single Family Residential
17 116481 RK	MHP : MR	Mobile Home Park : Multiple	Single Family Residential
17 116551 RK	MHP : MR	Mobile Home Park : Multiple	Single Family Residential
17 116547 RK	MHP : MR	Mobile Home Park : Multiple	Single Family Residential
17 116550 RK	MHP : MR	Mobile Home Park : Multiple	Single Family Residential
17 116477 RK	MHP : MR	Mobile Home Park : Multiple	Single Family Residential
17 116549 RK	MHP : MR	Mobile Home Park : Multiple	Single Family Residential

Accessory Dwelling Units

Index # - File Name: 1.0022 - Single Family Dwellings Data\_Snohomish County.pdf

17 116546 RK	MHP : MR	Mobile Home Park : Multiple Single Family Residential
17 116548 RK	MHP : MR	Mobile Home Park : Multiple Single Family Residential
17 116478 RK	MHP : MR	Mobile Home Park : Multiple Single Family Residential
17 116482 RK	MHP : MR	Mobile Home Park : Multiple Single Family Residential
17 117254 RK	MHP : MR	Mobile Home Park : Multiple Single Family Residential
17 117259 RK	MHP : MR	Mobile Home Park : Multiple Single Family Residential
17 112816 RK	R-7,200(PRD)	Residential 7,200 sq. ft. SFR-Basic
17 112817 RK	R-7,200(PRD)	Residential 7,200 sq. ft. SFR-Basic
17 112818 RK	R-7,200(PRD)	Residential 7,200 sq. ft. SFR-Basic
17 112820 RK	R-7,200(PRD)	Residential 7,200 sq. ft. SFR-Basic
17 112821 RK	R-7,200(PRD)	Residential 7,200 sq. ft. SFR-Basic
17 112822 RK	R-7,200(PRD)	Residential 7,200 sq. ft. SFR-Basic
17 112824 RK	R-7,200(PRD)	Residential 7,200 sq. ft. SFR-Basic
17 112819 RK	R-7,200(PRD)	Residential 7,200 sq. ft. SFR-Basic
17 112826 RK	R-7,200(PRD)	Residential 7,200 sq. ft. SFR-Basic
17 112823 RK	R-7,200(PRD)	Residential 7,200 sq. ft. SFR-Basic
17 112833 RK	R-7,200(PRD)	Residential 7,200 sq. ft. SFR-Basic
17 112831 RK	R-7,200(PRD)	Residential 7,200 sq. ft. SFR-Basic
17 112835 RK	R-7,200(PRD)	Residential 7,200 sq. ft. SFR-Basic
17 112829 RK	R-7,200(PRD)	Residential 7,200 sq. ft. SFR-Basic
17 112834 RK	R-7,200(PRD)	Residential 7,200 sq. ft. SFR-Basic
17 112839 RK	R-7,200(PRD)	Residential 7,200 sq. ft. SFR-Basic
17 111929 RK	R-7,200(PRD)	Residential 7,200 sq. ft. SFR-Basic
17 111930 RK	R-7,200(PRD)	Residential 7,200 sq. ft. SFR-Basic
17 107269 RK	R-7,200(PRD)	Residential 7,200 sq. ft. SFR-Basic
17 111934 RK	R-7,200(PRD)	Residential 7,200 sq. ft. SFR-Basic
17 111935 RK	R-7,200(PRD)	Residential 7,200 sq. ft. SFR-Basic
17 112444 RK	R-7,200(PRD)	Residential 7,200 sq. ft. SFR-Basic
17 108751 RK	R-7,200(PRD)	Residential 7,200 sq. ft. SFR-Basic
17 108747 RK	R-7,200(PRD)	Residential 7,200 sq. ft. SFR-Basic
17 112247 RK	R-7,200(PRD)	Residential 7,200 sq. ft. SFR-Basic
17 112248 RK	R-7,200(PRD)	Residential 7,200 sq. ft. SFR-Basic
17 112249 RK	R-7,200(PRD)	Residential 7,200 sq. ft. SFR-Basic
17 112390 RK	R-7,200(PRD)	Residential 7,200 sq. ft. SFR-Basic
17 112391 RK	R-7,200(PRD)	Residential 7,200 sq. ft. SFR-Basic
17 112442 RK	R-7,200(PRD)	Residential 7,200 sq. ft. SFR-Basic
17 112394 RK	R-7,200(PRD)	Residential 7,200 sq. ft. SFR-Basic
17 112443 RK	R-7,200(PRD)	Residential 7,200 sq. ft. SFR-Basic
17 108774 RK	LDMR : R-7,20	Low Density Multiple Reside SFR-Basic
17 108777 RK	LDMR : R-7,20	Low Density Multiple Reside SFR-Basic
17 108781 RK	LDMR : R-7,20	Low Density Multiple Reside SFR-Basic
17 108780 RK	LDMR : R-7,20	Low Density Multiple Reside SFR-Basic
17 108785 RK	LDMR : R-7,20	Low Density Multiple Reside SFR-Basic
17 108786 RK	LDMR : R-7,20	Low Density Multiple Reside SFR-Basic
17 108788 RK	LDMR : R-7,20	Low Density Multiple Reside SFR-Basic
17 108793 RK	LDMR : R-7,20	Low Density Multiple Reside SFR-Basic
17 108794 RK	LDMR : R-7,20	Low Density Multiple Reside SFR-Basic

Accessory Dwelling Units

Index # - File Name: 1.0022 - Single Family Dwellings Data\_Snohomish County.pdf

17 108792 RK	LDMR : R-7,20 Low Density Multiple Reside SFR-Basic		
17 108787 RK	LDMR : R-7,20 Low Density Multiple Reside SFR-Basic		
17 108789 RK	LDMR : R-7,20 Low Density Multiple Reside SFR-Basic		
17 108784 RK	LDMR : R-7,20 Low Density Multiple Reside SFR-Basic		
17 108782 RK	LDMR : R-7,20 Low Density Multiple Reside SFR-Basic		
17 108778 RK	LDMR : R-7,20 Low Density Multiple Reside SFR-Basic		
17 108779 RK	LDMR : R-7,20 Low Density Multiple Reside SFR-Basic		
17 108772 RK	LDMR : R-7,20 Low Density Multiple Reside SFR-Basic		
17 108773 RK	LDMR : R-7,20 Low Density Multiple Reside SFR-Basic		
17 107537 RK	LDMR : R-7,20 Low Density Multiple Reside SFR-Basic		
17 107528 RK	LDMR : R-7,20 Low Density Multiple Reside SFR-Basic		
17 107527 RK	LDMR : R-7,20 Low Density Multiple Reside SFR-Basic		
17 107526 RK	LDMR : R-7,20 Low Density Multiple Reside SFR-Basic		
17 108798 RK	LDMR : R-7,20 Low Density Multiple Reside SFR-Basic		
17 107462 RK	R-5	Rural-5 Acre	SFR-Basic
17 107827 RK	MR	Multiple Residential	SFR-Basic
17 108759 RK	MR	Multiple Residential	SFR-Basic
17 108764 RK	MR	Multiple Residential	SFR-Basic
17 108763 RK	MR	Multiple Residential	SFR-Basic
17 108760 RK	MR	Multiple Residential	SFR-Basic
17 108769 RK	MR	Multiple Residential	SFR-Basic
17 107831 RK	MR	Multiple Residential	SFR-Basic
17 107829 RK	MR	Multiple Residential	SFR-Basic
17 107828 RK	MR	Multiple Residential	SFR-Basic
17 109180 RK	MR	Multiple Residential	SFR-Basic
17 109181 RK	MR	Multiple Residential	SFR-Basic
17 109182 RK	MR	Multiple Residential	SFR-Basic
17 108770 RK	MR	Multiple Residential	SFR-Basic
17 108765 RK	MR	Multiple Residential	SFR-Basic
17 108768 RK	MR	Multiple Residential	SFR-Basic
17 109179 RK	MR	Multiple Residential	SFR-Basic
17 107567 RK	R-5	Rural-5 Acre	Single Family Residential
17 110501 MH	R-5	Rural-5 Acre	Double Wide
17 110621 RK	R-5	Rural-5 Acre	SFR-Basic
17 111655 RK	R-5	Rural-5 Acre	Single Family Residential
17 117377 RK	R-5	Rural-5 Acre	SFR-Basic
17 117383 RK	R-5	Rural-5 Acre	SFR-Basic
17 117386 RK	R-5	Rural-5 Acre	SFR-Basic
17 117379 RK	R-5	Rural-5 Acre	SFR-Basic
17 108383 RK	R-5	Rural-5 Acre	Single Family Residential
17 116150 RK	R-7,200	Residential 7,200 sq. ft.	SFR-Basic
17 116622 RK	R-7,200	Residential 7,200 sq. ft.	SFR-Basic
17 116624 RK	R-7,200	Residential 7,200 sq. ft.	SFR-Basic
17 116152 RK	R-7,200	Residential 7,200 sq. ft.	SFR-Basic
17 115989 RK	R-5	Rural-5 Acre	Single Family Residential
17 118445 RK	R-5	Rural-5 Acre	SFR-Basic
17 118254 RK	R-5	Rural-5 Acre	SFR-Basic



Accessory Dwelling Units

Index # - File Name: 1.0022 - Single Family Dwellings Data\_Snohomish County.pdf

17 118778 RK	MR : R-8,400	Multiple Residential :	Reside SFR-Basic
17 118643 RK	MR : R-8,400	Multiple Residential :	Reside SFR-Basic
17 118787 RK	MR : R-8,400	Multiple Residential :	Reside SFR-Basic
17 118788 RK	MR : R-8,400	Multiple Residential :	Reside SFR-Basic
17 119592 RK	MR : R-8,400	Multiple Residential :	Reside SFR-Basic
17 116705 000 01 RK	LDMR : R-8,40	Low Density Multiple Reside	Single Family Residential
17 117822 RK	R-7,200	Residential 7,200 sq. ft.	SFR-Basic
17 117823 RK	R-7,200	Residential 7,200 sq. ft.	SFR-Basic
17 117826 RK	R-7,200	Residential 7,200 sq. ft.	SFR-Basic
18 122084 RK	R-7,200	Residential 7,200 sq. ft.	SFR-Basic
18 127423 RK	R-7,200	Residential 7,200 sq. ft.	SFR-Basic
18 127424 RK	R-7,200	Residential 7,200 sq. ft.	SFR-Basic
18 114346 000 01 RK	R-5	Rural-5 Acre	Single Family Residential
18 120791 RK	R-5	Rural-5 Acre	Single Family Residential
18 120123 RK	A-10	Agriculture-10 Acre	Single Family Residential
18 121396 RK	R-9,600	Residential 9,600 sq. ft.	Single Family Residential
18 116641 RK	R-9,600	Residential 9,600 sq. ft.	SFR-Basic
18 116643 RK	R-9,600	Residential 9,600 sq. ft.	SFR-Basic
18 119113 RK	R-9,600	Residential 9,600 sq. ft.	Single Family Residential
18 112046 RK	R-5	Rural-5 Acre	Single Family Residential
18 112049 RK	R-5	Rural-5 Acre	Single Family Residential
17 116655 RK	R-5	Rural-5 Acre	Single Family Residential
17 117481 RK	LDMR : R-7,20	Low Density Multiple Reside	SFR-Basic
17 117482 RK	LDMR : R-7,20	Low Density Multiple Reside	SFR-Basic
17 117483 RK	LDMR : R-7,20	Low Density Multiple Reside	SFR-Basic
17 117484 RK	LDMR : R-7,20	Low Density Multiple Reside	SFR-Basic
17 117486 RK	LDMR : R-7,20	Low Density Multiple Reside	SFR-Basic
17 117487 RK	LDMR : R-7,20	Low Density Multiple Reside	SFR-Basic
17 117488 RK	LDMR : R-7,20	Low Density Multiple Reside	SFR-Basic
17 117489 RK	LDMR : R-7,20	Low Density Multiple Reside	SFR-Basic
17 117490 RK	LDMR : R-7,20	Low Density Multiple Reside	SFR-Basic
17 117491 RK	LDMR : R-7,20	Low Density Multiple Reside	SFR-Basic
18 111930 RK	R-5	Rural-5 Acre	Single Family Residential
18 125666 RK	LDMR : R-8,40	Low Density Multiple Reside	Single Family Residential
18 125934 RK	LDMR : R-8,40	Low Density Multiple Reside	Single Family Residential
17 119575 RK	MR : R-8,400	Multiple Residential :	Reside SFR-Basic
17 118780 RK	MR : R-8,400	Multiple Residential :	Reside SFR-Basic
17 118256 RK	R-5	Rural-5 Acre	SFR-Basic
17 118444 RK	R-5	Rural-5 Acre	SFR-Basic
17 118487 RK	R-5	Rural-5 Acre	SFR-Basic
17 118488 RK	R-5	Rural-5 Acre	SFR-Basic
18 101305 RK	MR : R-8,400	Multiple Residential :	Reside SFR-Basic
18 114279 RK	MR : R-8,400	Multiple Residential :	Reside SFR-Basic
18 114280 RK	MR : R-8,400	Multiple Residential :	Reside SFR-Basic
18 114282 RK	MR : R-8,400	Multiple Residential :	Reside SFR-Basic
18 114283 RK	MR : R-8,400	Multiple Residential :	Reside SFR-Basic
18 101304 RK	MR : R-8,400	Multiple Residential :	Reside SFR-Basic

Accessory Dwelling Units

Index # - File Name: 1.0022 - Single Family Dwellings Data\_Snohomish County.pdf

18 101303 RK	MR : R-8,400	Multiple Residential :	Reside SFR-Basic
17 119576 RK	MR : R-8,400	Multiple Residential :	Reside SFR-Basic
17 118779 RK	MR : R-8,400	Multiple Residential :	Reside SFR-Basic
17 117956 RK	R-5	Rural-5 Acre	Single Family Residential
18 101270 RK	LDMR : R-9,60	Low Density Multiple	Reside SFR-Basic
18 101271 RK	LDMR : R-9,60	Low Density Multiple	Reside SFR-Basic
18 101295 RK	LDMR : R-9,60	Low Density Multiple	Reside SFR-Basic
17 119589 RK	LDMR : R-9,60	Low Density Multiple	Reside SFR-Basic
17 119588 RK	LDMR : R-9,60	Low Density Multiple	Reside SFR-Basic
17 119587 RK	LDMR : R-9,60	Low Density Multiple	Reside SFR-Basic
17 119585 RK	LDMR : R-9,60	Low Density Multiple	Reside SFR-Basic
17 118781 RK	LDMR : R-9,60	Low Density Multiple	Reside SFR-Basic
17 118772 RK	LDMR : R-9,60	Low Density Multiple	Reside SFR-Basic
17 118765 RK	LDMR : R-9,60	Low Density Multiple	Reside SFR-Basic
17 118768 RK	LDMR : R-9,60	Low Density Multiple	Reside SFR-Basic
17 119213 RK	R-8,400	Residential 8,400 sq. ft.	SFR-Basic
17 119293 RK	R-8,400	Residential 8,400 sq. ft.	SFR-Basic
17 119292 RK	R-8,400	Residential 8,400 sq. ft.	SFR-Basic
17 119215 RK	R-8,400	Residential 8,400 sq. ft.	SFR-Basic
17 119216 RK	R-8,400	Residential 8,400 sq. ft.	SFR-Basic
17 119217 RK	R-8,400	Residential 8,400 sq. ft.	SFR-Basic
17 119219 RK	R-8,400	Residential 8,400 sq. ft.	SFR-Basic
17 119220 RK	R-8,400	Residential 8,400 sq. ft.	SFR-Basic
17 119221 RK	R-8,400	Residential 8,400 sq. ft.	SFR-Basic
17 119223 RK	R-8,400	Residential 8,400 sq. ft.	SFR-Basic
17 119224 RK	R-8,400	Residential 8,400 sq. ft.	SFR-Basic
17 119226 RK	R-8,400	Residential 8,400 sq. ft.	SFR-Basic
17 119294 RK	R-8,400	Residential 8,400 sq. ft.	SFR-Basic
18 101958 RK	LDMR : MR : R	Low Density Multiple	Reside Duplex-Basic
18 101959 RK	LDMR : MR : R	Low Density Multiple	Reside Duplex-Basic
18 101960 RK	LDMR : MR : R	Low Density Multiple	Reside Duplex-Basic
18 101963 RK	LDMR : MR : R	Low Density Multiple	Reside Duplex-Basic
18 101962 RK	LDMR : MR : R	Low Density Multiple	Reside Duplex-Basic
18 115086 RK	R-5	Rural-5 Acre	SFR-Basic
17 118911 RK	R-7,200	Residential 7,200 sq. ft.	Duplex
17 119060 MH	R-5	Rural-5 Acre	Double Wide
17 119155 RK	R-5	Rural-5 Acre	Single Family Residential
17 119282 RK	R-5	Rural-5 Acre	Single Family Residential
17 119805 000 01 RK	R-5	Rural-5 Acre	Single Family Residential
18 119289 RK	R-7,200	Residential 7,200 sq. ft.	SFR-Basic
18 119290 RK	R-7,200	Residential 7,200 sq. ft.	SFR-Basic
18 119284 RK	R-7,200	Residential 7,200 sq. ft.	SFR-Basic
18 119286 RK	R-7,200	Residential 7,200 sq. ft.	SFR-Basic
18 119352 RK	R-7,200	Residential 7,200 sq. ft.	SFR-Basic
18 119295 RK	R-7,200	Residential 7,200 sq. ft.	SFR-Basic
18 119294 RK	R-7,200	Residential 7,200 sq. ft.	SFR-Basic
18 119288 RK	R-7,200	Residential 7,200 sq. ft.	SFR-Basic

Accessory Dwelling Units

Index # - File Name: 1.0022 - Single Family Dwellings Data\_Snohomish County.pdf

17 119949 000 01 RK	F	Forestry	Single Family Residential
18 123153 RK	R-5	Rural-5 Acre	Single Family Residential
18 125355 RK	R-5	Rural-5 Acre	Single Family Residential
18 123176 RK	R-5	Rural-5 Acre	Single Family Residential
18 119017 RK	R-5	Rural-5 Acre	Single Family Residential
18 117248 RK	R-5	Rural-5 Acre	Single Family Residential
18 119019 RK	R-5	Rural-5 Acre	Single Family Residential
18 117257 RK	R-5	Rural-5 Acre	Single Family Residential
18 123256 RK	R-5	Rural-5 Acre	Single Family Residential
18 125369 RK	R-5	Rural-5 Acre	Single Family Residential
18 125379 RK	R-5	Rural-5 Acre	Single Family Residential
18 100433 RK	R-5	Rural-5 Acre	Single Family Residential
17 118422 RK	R-5	Rural-5 Acre	SFR-Basic
17 118423 RK	R-5	Rural-5 Acre	SFR-Basic
17 118424 RK	R-5	Rural-5 Acre	SFR-Basic
17 118255 RK	R-5	Rural-5 Acre	SFR-Basic
17 118425 RK	R-5	Rural-5 Acre	SFR-Basic
17 118443 RK	R-5	Rural-5 Acre	SFR-Basic
17 118442 RK	R-5	Rural-5 Acre	SFR-Basic
17 118446 RK	R-5	Rural-5 Acre	SFR-Basic
18 127523 RK	R-7,200	Residential 7,200 sq. ft.	SFR-Basic
18 125284 RK	R-7,200	Residential 7,200 sq. ft.	SFR-Basic
18 125409 RK	R-5	Rural-5 Acre	SFR-Basic
18 125411 RK	R-5	Rural-5 Acre	SFR-Basic
18 117968 RK	R-7,200	Residential 7,200 sq. ft.	SFR-Basic
18 117969 RK	R-7,200	Residential 7,200 sq. ft.	SFR-Basic
18 117971 RK	R-7,200	Residential 7,200 sq. ft.	SFR-Basic
18 117972 RK	R-7,200	Residential 7,200 sq. ft.	SFR-Basic
18 117973 RK	R-7,200	Residential 7,200 sq. ft.	SFR-Basic
18 117985 RK	R-7,200	Residential 7,200 sq. ft.	SFR-Basic
18 117986 RK	R-7,200	Residential 7,200 sq. ft.	SFR-Basic
18 118147 RK	R-7,200	Residential 7,200 sq. ft.	SFR-Basic
18 117989 RK	R-7,200	Residential 7,200 sq. ft.	SFR-Basic
18 117991 RK	R-7,200	Residential 7,200 sq. ft.	SFR-Basic
18 117992 RK	R-7,200	Residential 7,200 sq. ft.	SFR-Basic
18 117641 RK	R-7,200	Residential 7,200 sq. ft.	SFR-Basic
18 117635 RK	R-7,200	Residential 7,200 sq. ft.	SFR-Basic
18 117631 RK	R-7,200	Residential 7,200 sq. ft.	SFR-Basic
18 117621 RK	R-7,200	Residential 7,200 sq. ft.	SFR-Basic
18 115815 RK	R-7,200	Residential 7,200 sq. ft.	SFR-Basic
18 115804 RK	R-7,200	Residential 7,200 sq. ft.	SFR-Basic
18 115062 RK	R-7,200	Residential 7,200 sq. ft.	SFR-Basic
18 115067 RK	R-7,200	Residential 7,200 sq. ft.	SFR-Basic
18 115064 RK	R-7,200	Residential 7,200 sq. ft.	SFR-Basic
18 115060 RK	R-7,200	Residential 7,200 sq. ft.	SFR-Basic
18 118484 RK	R-5	Rural-5 Acre	Single Family Residential
18 115835 RK	R-7,200	Residential 7,200 sq. ft.	SFR-Basic

Accessory Dwelling Units

Index # - File Name: 1.0022 - Single Family Dwellings Data\_Snohomish County.pdf

18 115117 RK	R-7,200	Residential 7,200 sq. ft.	SFR-Basic
17 116888 RK	R-7,200	Residential 7,200 sq. ft.	SFR-Basic
18 115830 RK	R-7,200	Residential 7,200 sq. ft.	SFR-Basic
18 115834 RK	R-7,200	Residential 7,200 sq. ft.	SFR-Basic
18 115069 RK	R-7,200	Residential 7,200 sq. ft.	SFR-Basic
18 115863 RK	R-7,200	Residential 7,200 sq. ft.	SFR-Basic
18 116367 RK	R-7,200	Residential 7,200 sq. ft.	SFR-Basic
18 116370 RK	R-7,200	Residential 7,200 sq. ft.	SFR-Basic
18 116360 RK	R-7,200	Residential 7,200 sq. ft.	SFR-Basic
18 116364 RK	R-7,200	Residential 7,200 sq. ft.	SFR-Basic
18 116369 RK	R-7,200	Residential 7,200 sq. ft.	SFR-Basic
18 116372 RK	R-7,200	Residential 7,200 sq. ft.	SFR-Basic
18 117629 RK	R-7,200	Residential 7,200 sq. ft.	SFR-Basic
18 117630 RK	R-7,200	Residential 7,200 sq. ft.	SFR-Basic
18 117632 RK	R-7,200	Residential 7,200 sq. ft.	SFR-Basic
18 117633 RK	R-7,200	Residential 7,200 sq. ft.	SFR-Basic
18 117636 RK	R-7,200	Residential 7,200 sq. ft.	SFR-Basic
18 117637 RK	R-7,200	Residential 7,200 sq. ft.	SFR-Basic
18 117656 RK	R-7,200	Residential 7,200 sq. ft.	SFR-Basic
18 117638 RK	R-7,200	Residential 7,200 sq. ft.	SFR-Basic
18 117933 RK	R-7,200	Residential 7,200 sq. ft.	SFR-Basic
18 117935 RK	R-7,200	Residential 7,200 sq. ft.	SFR-Basic
18 117936 RK	R-7,200	Residential 7,200 sq. ft.	SFR-Basic
18 117937 RK	R-7,200	Residential 7,200 sq. ft.	SFR-Basic
18 117939 RK	R-7,200	Residential 7,200 sq. ft.	SFR-Basic
18 117942 RK	R-7,200	Residential 7,200 sq. ft.	SFR-Basic
18 117946 RK	R-7,200	Residential 7,200 sq. ft.	SFR-Basic
18 117948 RK	R-7,200	Residential 7,200 sq. ft.	SFR-Basic
18 117949 RK	R-7,200	Residential 7,200 sq. ft.	SFR-Basic
18 117952 RK	R-7,200	Residential 7,200 sq. ft.	SFR-Basic
18 117951 RK	R-7,200	Residential 7,200 sq. ft.	SFR-Basic
18 117953 RK	R-7,200	Residential 7,200 sq. ft.	SFR-Basic
18 117954 RK	R-7,200	Residential 7,200 sq. ft.	SFR-Basic
18 117957 RK	R-7,200	Residential 7,200 sq. ft.	SFR-Basic
18 117958 RK	R-7,200	Residential 7,200 sq. ft.	SFR-Basic
18 117960 RK	R-7,200	Residential 7,200 sq. ft.	SFR-Basic
18 117961 RK	R-7,200	Residential 7,200 sq. ft.	SFR-Basic
18 117962 RK	R-7,200	Residential 7,200 sq. ft.	SFR-Basic
18 117963 RK	R-7,200	Residential 7,200 sq. ft.	SFR-Basic
18 117964 RK	R-7,200	Residential 7,200 sq. ft.	SFR-Basic
18 117965 RK	R-7,200	Residential 7,200 sq. ft.	SFR-Basic
18 115788 RK	R-7,200	Residential 7,200 sq. ft.	SFR-Basic
18 115791 RK	R-7,200	Residential 7,200 sq. ft.	SFR-Basic
18 113032 RK	R-7,200	Residential 7,200 sq. ft.	SFR-Basic
18 115767 RK	R-7,200	Residential 7,200 sq. ft.	SFR-Basic
18 115789 RK	R-7,200	Residential 7,200 sq. ft.	SFR-Basic
18 113034 RK	R-7,200	Residential 7,200 sq. ft.	SFR-Basic

Accessory Dwelling Units

Index # - File Name: 1.0022 - Single Family Dwellings Data\_Snohomish County.pdf

18 113322 RK	R-7,200	Residential 7,200 sq. ft.	SFR-Basic
18 113316 RK	R-7,200	Residential 7,200 sq. ft.	SFR-Basic
18 113317 RK	R-7,200	Residential 7,200 sq. ft.	SFR-Basic
18 113319 RK	R-7,200	Residential 7,200 sq. ft.	SFR-Basic
18 114405 RK	R-7,200	Residential 7,200 sq. ft.	SFR-Basic
18 114413 RK	R-7,200	Residential 7,200 sq. ft.	SFR-Basic
18 114414 RK	R-7,200	Residential 7,200 sq. ft.	SFR-Basic
18 114407 RK	R-7,200	Residential 7,200 sq. ft.	SFR-Basic
18 116766 RK	R-7,200	Residential 7,200 sq. ft.	SFR-Basic
18 116765 RK	R-7,200	Residential 7,200 sq. ft.	SFR-Basic
18 118672 RK	R-7,200	Residential 7,200 sq. ft.	SFR-Basic
18 118673 RK	R-7,200	Residential 7,200 sq. ft.	SFR-Basic
18 120514 RK	R-7,200	Residential 7,200 sq. ft.	SFR-Basic
18 120216 RK	R-7,200	Residential 7,200 sq. ft.	SFR-Basic
18 120312 RK	R-7,200	Residential 7,200 sq. ft.	SFR-Basic
18 124211 RK	R-7,200	Residential 7,200 sq. ft.	SFR-Basic
18 120499 RK	R-7,200	Residential 7,200 sq. ft.	SFR-Basic
17 115319 000 01 RK	R-5	Rural-5 Acre	Single Family Residential
17 115343 RK	A-10	Agriculture-10 Acre	Single Family Residential
17 117380 RK	R-5	Rural-5 Acre	SFR-Basic
18 116136 RK	R-5	Rural-5 Acre	SFR-Basic
18 115522 RK	R-5	Rural-5 Acre	Single Family Residential
18 122915 RK	R-5	Rural-5 Acre	SFR-Basic
18 102014 RK	R-7,200 : R-9,6	Residential 7,200 sq. ft. : Re	SFR-Basic
18 102015 RK	R-7,200 : R-9,6	Residential 7,200 sq. ft. : Re	SFR-Basic
18 102027 RK	R-7,200 : R-9,6	Residential 7,200 sq. ft. : Re	Single Family Residential
18 111851 RK	R-7,200 : R-9,6	Residential 7,200 sq. ft. : Re	SFR-Basic
18 111850 RK	R-7,200 : R-9,6	Residential 7,200 sq. ft. : Re	SFR-Basic
18 101400 RK	RRT-10	Rural Resource Transition-10	Single Family Residential
17 119953 RK	RRT-10	Rural Resource Transition-10	Single Family Residential
17 114536 RK	R-5	Rural-5 Acre	Single Family Residential
17 114540 RK	R-5	Rural-5 Acre	Single Family Residential
18 113294 RK	R-5	Rural-5 Acre	Single Family Residential
17 119491 RK	R-5	Rural-5 Acre	Single Family Residential
18 115939 RK	R-5	Rural-5 Acre	Single Family Residential
17 119483 RK	R-5	Rural-5 Acre	Single Family Residential
17 118892 RK	R-5	Rural-5 Acre	SFR-Basic
18 114445 RK	R-5	Rural-5 Acre	SFR-Basic
18 122112 RK	R-5	Rural-5 Acre	SFR-Basic
18 119159 RK	R-5	Rural-5 Acre	SFR-Basic
18 119157 RK	R-5	Rural-5 Acre	SFR-Basic
18 122113 RK	R-5	Rural-5 Acre	SFR-Basic
18 119158 RK	R-5	Rural-5 Acre	SFR-Basic
18 122630 RK	R-5	Rural-5 Acre	SFR-Basic
18 122629 RK	R-5	Rural-5 Acre	SFR-Basic
18 123248 RK	R-5	Rural-5 Acre	SFR-Basic
18 122921 RK	R-5	Rural-5 Acre	SFR-Basic

Accessory Dwelling Units

Index # - File Name: 1.0022 - Single Family Dwellings Data\_Snohomish County.pdf

18 122922 RK	R-5	Rural-5 Acre	SFR-Basic
18 114443 RK	R-5	Rural-5 Acre	SFR-Basic
18 100070 RK	R-5	Rural-5 Acre	SFR-Basic
17 117381 RK	R-5	Rural-5 Acre	SFR-Basic
18 100055 RK	R-5	Rural-5 Acre	SFR-Basic
18 101885 RK	R-5	Rural-5 Acre	SFR-Basic
18 122110 RK	R-5	Rural-5 Acre	SFR-Basic
18 122111 RK	R-5	Rural-5 Acre	SFR-Basic
18 113215 RK	R-7,200	Residential 7,200 sq. ft.	Single Family Residential
17 119960 RK	R-5	Rural-5 Acre	Single Family Residential
18 100390 MH	RD	Rural Diversification	Double Wide
18 113456 RK	R-7,200	Residential 7,200 sq. ft.	Single Family Residential
17 117322 RK	R-5	Rural-5 Acre	Single Family Residential
17 117325 RK	R-5	Rural-5 Acre	Single Family Residential
17 112830 RK	R-7,200(PRD)	Residential 7,200 sq. ft.	SFR-Basic
17 110674 000 01 RK	F	Forestry	Single Family Residential
18 116604 000 01 RK	R-5	Rural-5 Acre	Single Family Residential
18 114574 RK	LDMR	Low Density Multiple Reside	Single Family Residential
17 114964 RK	R-7,200(PRD)	Residential 7,200 sq. ft.	SFR-Basic
17 114965 RK	R-7,200(PRD)	Residential 7,200 sq. ft.	SFR-Basic
17 114966 RK	R-7,200(PRD)	Residential 7,200 sq. ft.	SFR-Basic
17 114969 RK	R-7,200(PRD)	Residential 7,200 sq. ft.	SFR-Basic
17 114940 RK	R-7,200(PRD)	Residential 7,200 sq. ft.	SFR-Basic
17 114862 RK	R-7,200(PRD)	Residential 7,200 sq. ft.	SFR-Basic
18 125159 RK	R-5	Rural-5 Acre	SFR-Basic
18 115944 RK	R-5	Rural-5 Acre	Single Family Residential
17 118895 RK	R-5	Rural-5 Acre	SFR-Basic
17 114935 RK	R-7,200(PRD)	Residential 7,200 sq. ft.	SFR-Basic
17 114932 RK	R-7,200(PRD)	Residential 7,200 sq. ft.	SFR-Basic
17 114934 RK	R-7,200(PRD)	Residential 7,200 sq. ft.	SFR-Basic
17 114933 RK	R-7,200(PRD)	Residential 7,200 sq. ft.	SFR-Basic
17 114938 RK	R-7,200(PRD)	Residential 7,200 sq. ft.	SFR-Basic
17 114864 RK	R-7,200(PRD)	Residential 7,200 sq. ft.	SFR-Basic
17 114889 RK	R-7,200(PRD)	Residential 7,200 sq. ft.	SFR-Basic
17 114890 RK	R-7,200(PRD)	Residential 7,200 sq. ft.	SFR-Basic
17 114895 RK	R-7,200(PRD)	Residential 7,200 sq. ft.	SFR-Basic
17 114896 RK	R-7,200(PRD)	Residential 7,200 sq. ft.	SFR-Basic
17 119832 RK	R-7,200(PRD)	Residential 7,200 sq. ft.	SFR-Basic
17 119831 RK	R-7,200(PRD)	Residential 7,200 sq. ft.	SFR-Basic
18 113242 RK	R-7,200(PRD)	Residential 7,200 sq. ft.	SFR-Basic
18 114472 RK	R-7,200(PRD)	Residential 7,200 sq. ft.	SFR-Basic
18 116189 RK	R-7,200(PRD)	Residential 7,200 sq. ft.	SFR-Basic
18 116191 RK	R-7,200(PRD)	Residential 7,200 sq. ft.	SFR-Basic
18 116194 RK	R-7,200(PRD)	Residential 7,200 sq. ft.	SFR-Basic
18 116196 RK	R-7,200(PRD)	Residential 7,200 sq. ft.	SFR-Basic
18 102009 RK	R-7,200(PRD)	Residential 7,200 sq. ft.	SFR-Basic
18 116197 RK	R-7,200(PRD)	Residential 7,200 sq. ft.	SFR-Basic

Accessory Dwelling Units

Index # - File Name: 1.0022 - Single Family Dwellings Data\_Snohomish County.pdf

18 116151 RK	R-7,200(PRD)	Residential 7,200 sq. ft.	SFR-Basic
18 113241 RK	R-7,200(PRD)	Residential 7,200 sq. ft.	SFR-Basic
17 118834 RK	R-7,200	Residential 7,200 sq. ft.	Single Family Residential
18 114518 RK	R-7,200(PRD)	Residential 7,200 sq. ft.	SFR-Basic
17 119112 RK	R-7,200	Residential 7,200 sq. ft.	Single Family Residential
17 117940 RK	R-7,200	Residential 7,200 sq. ft.	Single Family Residential
17 119109 RK	R-7,200	Residential 7,200 sq. ft.	Single Family Residential
17 118297 RK	R-7,200	Residential 7,200 sq. ft.	Single Family Residential
17 118296 RK	R-7,200	Residential 7,200 sq. ft.	Single Family Residential
17 117939 RK	R-7,200	Residential 7,200 sq. ft.	Single Family Residential
17 118299 RK	R-7,200	Residential 7,200 sq. ft.	Single Family Residential
17 117633 RK	R-7,200	Residential 7,200 sq. ft.	Single Family Residential
17 117635 RK	R-7,200	Residential 7,200 sq. ft.	Single Family Residential
18 115908 RK	RRT-10	Rural Resource Transition-10	Single Family Residential
18 120209 RK	R-7,200(PRD)	Residential 7,200 sq. ft.	SFR-Basic
18 120208 RK	R-7,200(PRD)	Residential 7,200 sq. ft.	SFR-Basic
18 116058 RK	R-7,200(PRD)	Residential 7,200 sq. ft.	SFR-Basic
18 114469 RK	R-7,200(PRD)	Residential 7,200 sq. ft.	SFR-Basic
18 116188 RK	R-7,200(PRD)	Residential 7,200 sq. ft.	SFR-Basic
18 116187 RK	R-7,200(PRD)	Residential 7,200 sq. ft.	SFR-Basic
18 114448 RK	R-7,200(PRD)	Residential 7,200 sq. ft.	SFR-Basic
18 116070 RK	R-7,200(PRD)	Residential 7,200 sq. ft.	SFR-Basic
18 101617 RK	R-7,200(PRD)	Residential 7,200 sq. ft.	SFR-Basic
18 113222 RK	R-7,200(PRD)	Residential 7,200 sq. ft.	SFR-Basic
18 116077 RK	R-7,200(PRD)	Residential 7,200 sq. ft.	SFR-Basic
18 114468 RK	R-7,200(PRD)	Residential 7,200 sq. ft.	SFR-Basic
18 114467 RK	R-7,200(PRD)	Residential 7,200 sq. ft.	SFR-Basic
18 113223 RK	R-7,200(PRD)	Residential 7,200 sq. ft.	SFR-Basic
18 101621 RK	R-7,200(PRD)	Residential 7,200 sq. ft.	SFR-Basic
18 113224 RK	R-7,200(PRD)	Residential 7,200 sq. ft.	SFR-Basic
18 113225 RK	R-7,200(PRD)	Residential 7,200 sq. ft.	SFR-Basic
17 119828 RK	R-7,200(PRD)	Residential 7,200 sq. ft.	SFR-Basic
17 119827 RK	R-7,200(PRD)	Residential 7,200 sq. ft.	SFR-Basic
17 119829 RK	R-7,200(PRD)	Residential 7,200 sq. ft.	SFR-Basic
17 105894 RK	F	Forestry	SFR-Basic
18 123047 RK	R-7,200	Residential 7,200 sq. ft.	Duplex-Basic
18 112463 RK	MR	Multiple Residential	Duplex
17 109421 RK	R-5	Rural-5 Acre	Single Family Residential
17 109416 RK	R-5	Rural-5 Acre	Single Family Residential
17 110801 RK	R-5	Rural-5 Acre	SFR-Basic
17 110800 RK	R-5	Rural-5 Acre	SFR-Basic
18 121394 RK	R-5	Rural-5 Acre	Single Family Residential
18 120298 RK	R-5	Rural-5 Acre	Single Family Residential
18 113201 RK	R-5	Rural-5 Acre	Single Family Residential
18 121379 RK	R-5	Rural-5 Acre	Single Family Residential
18 112770 RK	R-5	Rural-5 Acre	Single Family Residential
17 119695 RK	R-5	Rural-5 Acre	Single Family Residential

Accessory Dwelling Units

Index # - File Name: 1.0022 - Single Family Dwellings Data\_Snohomish County.pdf

17 109285 RK	LDMR : R-8,40 Low Density Multiple Reside Single Family Residential		
17 109287 RK	LDMR : R-8,40 Low Density Multiple Reside Single Family Residential		
17 109288 RK	LDMR : R-8,40 Low Density Multiple Reside Single Family Residential		
17 109289 RK	LDMR : R-8,40 Low Density Multiple Reside Single Family Residential		
18 118476 RK	R-5	Rural-5 Acre	Single Family Residential
17 115724 RK	R-5	Rural-5 Acre	SFR-Basic
17 119536 RK	R-5	Rural-5 Acre	SFR-Basic
17 115369 RK	R-5	Rural-5 Acre	SFR-Basic
17 115727 RK	R-5	Rural-5 Acre	SFR-Basic
17 116165 RK	R-5	Rural-5 Acre	SFR-Basic
17 119537 RK	R-5	Rural-5 Acre	SFR-Basic
17 115722 RK	R-5	Rural-5 Acre	SFR-Basic
17 119538 RK	R-5	Rural-5 Acre	SFR-Basic
17 119540 RK	R-5	Rural-5 Acre	SFR-Basic
17 116166 RK	R-5	Rural-5 Acre	SFR-Basic
17 115720 RK	R-5	Rural-5 Acre	SFR-Basic
17 119723 RK	F	Forestry	Single Family Residential
17 118496 RK	R-7,200(PRD)	Residential 7,200 sq. ft.	SFR-Basic
17 118497 RK	R-7,200(PRD)	Residential 7,200 sq. ft.	SFR-Basic
17 118506 RK	R-7,200(PRD)	Residential 7,200 sq. ft.	SFR-Basic
17 118498 RK	R-7,200(PRD)	Residential 7,200 sq. ft.	SFR-Basic
17 118507 RK	R-7,200(PRD)	Residential 7,200 sq. ft.	SFR-Basic
17 118500 RK	R-7,200(PRD)	Residential 7,200 sq. ft.	SFR-Basic
17 118501 RK	R-7,200(PRD)	Residential 7,200 sq. ft.	SFR-Basic
17 118502 RK	R-7,200(PRD)	Residential 7,200 sq. ft.	SFR-Basic
17 118505 RK	R-7,200(PRD)	Residential 7,200 sq. ft.	SFR-Basic
18 113819 RK	LDMR	Low Density Multiple Reside	SFR-Basic
18 113823 RK	LDMR	Low Density Multiple Reside	SFR-Basic
18 113825 RK	LDMR	Low Density Multiple Reside	SFR-Basic
18 113827 RK	LDMR	Low Density Multiple Reside	SFR-Basic
18 113829 RK	LDMR	Low Density Multiple Reside	SFR-Basic
18 113830 RK	LDMR	Low Density Multiple Reside	SFR-Basic
18 113832 RK	LDMR	Low Density Multiple Reside	SFR-Basic
18 113834 RK	LDMR	Low Density Multiple Reside	SFR-Basic
18 113847 RK	LDMR	Low Density Multiple Reside	SFR-Basic
18 113850 RK	LDMR	Low Density Multiple Reside	SFR-Basic
18 113851 RK	LDMR	Low Density Multiple Reside	SFR-Basic
18 113917 RK	LDMR	Low Density Multiple Reside	SFR-Basic
18 113918 RK	LDMR	Low Density Multiple Reside	SFR-Basic
18 116203 RK	LDMR	Low Density Multiple Reside Duplex	
18 116207 RK	LDMR	Low Density Multiple Reside Duplex	
18 119007 000 01 RK	LDMR	Low Density Multiple Reside Single Family Residential	
18 119074 000 01 RK	LDMR	Low Density Multiple Reside Single Family Residential	
18 119076 000 01 RK	LDMR	Low Density Multiple Reside Single Family Residential	
18 119078 000 01 RK	LDMR	Low Density Multiple Reside Single Family Residential	
18 119080 000 01 RK	LDMR	Low Density Multiple Reside Single Family Residential	
18 101968 RK	RD	Rural Diversification	Single Family Residential



Accessory Dwelling Units

Index # - File Name: 1.0022 - Single Family Dwellings Data\_Snohomish County.pdf

18 118068 RK	R-5	Rural-5 Acre	SFR-Basic
18 101030 MH	RD	Rural Diversification	Double Wide
18 117574 RK	LDMR	Low Density Multiple Reside	SFR-Basic
18 117575 RK	LDMR	Low Density Multiple Reside	SFR-Basic
18 117578 RK	LDMR	Low Density Multiple Reside	SFR-Basic
18 117577 RK	LDMR	Low Density Multiple Reside	SFR-Basic
18 117580 RK	LDMR	Low Density Multiple Reside	SFR-Basic
18 117581 RK	LDMR	Low Density Multiple Reside	SFR-Basic
18 117583 RK	LDMR	Low Density Multiple Reside	SFR-Basic
18 117582 RK	LDMR	Low Density Multiple Reside	SFR-Basic
18 117584 RK	LDMR	Low Density Multiple Reside	SFR-Basic
18 117585 RK	LDMR	Low Density Multiple Reside	SFR-Basic
18 101267 RK	R-5	Rural-5 Acre	Single Family Residential
18 111820 RK	R-7,200	Residential 7,200 sq. ft.	Single Family Residential
18 111819 RK	R-7,200	Residential 7,200 sq. ft.	Single Family Residential
18 115708 RK	R-5	Rural-5 Acre	Single Family Residential
18 120769 RK	R-5	Rural-5 Acre	SFR-Basic
18 120770 RK	R-5	Rural-5 Acre	SFR-Basic
18 113575 RK	R-7,200 : R-8,4	Residential 7,200 sq. ft. : Re	Single Family Residential
18 113579 RK	R-7,200 : R-8,4	Residential 7,200 sq. ft. : Re	Single Family Residential
18 115763 RK	R-7,200 : R-8,4	Residential 7,200 sq. ft. : Re	SFR-Basic
18 115593 RK	R-7,200 : R-8,4	Residential 7,200 sq. ft. : Re	Duplex-Basic
18 115732 RK	R-7,200 : R-8,4	Residential 7,200 sq. ft. : Re	SFR-Basic
18 115734 RK	R-7,200 : R-8,4	Residential 7,200 sq. ft. : Re	SFR-Basic
18 115735 RK	R-7,200 : R-8,4	Residential 7,200 sq. ft. : Re	SFR-Basic
18 115736 RK	R-7,200 : R-8,4	Residential 7,200 sq. ft. : Re	SFR-Basic
18 115737 RK	R-7,200 : R-8,4	Residential 7,200 sq. ft. : Re	SFR-Basic
18 113788 000 01 RK	R-5	Rural-5 Acre	Single Family Residential
18 114004 RK	R-5	Rural-5 Acre	SFR-Basic
18 114008 RK	RC	Rural Conservation	SFR-Basic
18 122649 RK	R-7,200	Residential 7,200 sq. ft.	SFR-Basic
18 122650 RK	R-7,200	Residential 7,200 sq. ft.	SFR-Basic
18 101583 RK	R-7,200	Residential 7,200 sq. ft.	SFR-Basic
18 114227 MH	A-10	Agriculture-10 Acre	Single Wide
18 114611 RK	R-5	Rural-5 Acre	Single Family Residential
18 114270 RK	F	Forestry	Single Family Residential
18 114628 RK	R-5	Rural-5 Acre	Single Family Residential
18 122036 RK	MR	Multiple Residential	SFR-Basic
18 122037 RK	MR	Multiple Residential	SFR-Basic
18 122051 RK	MR	Multiple Residential	SFR-Basic
18 122119 RK	MR	Multiple Residential	SFR-Basic
18 122059 RK	MR	Multiple Residential	SFR-Basic
18 122060 RK	MR	Multiple Residential	SFR-Basic
18 122120 RK	MR	Multiple Residential	SFR-Basic
18 122109 RK	MR	Multiple Residential	SFR-Basic
18 122047 RK	MR	Multiple Residential	SFR-Basic
18 122050 RK	MR	Multiple Residential	SFR-Basic

Accessory Dwelling Units

Index # - File Name: 1.0022 - Single Family Dwellings Data\_Snohomish County.pdf

18 119247 RK	MR	Multiple Residential	Single Family Residential
18 121871 RK	MR	Multiple Residential	SFR-Basic
18 121875 RK	MR	Multiple Residential	SFR-Basic
18 121873 RK	MR	Multiple Residential	SFR-Basic
18 122065 RK	MR	Multiple Residential	SFR-Basic
18 122054 RK	MR	Multiple Residential	SFR-Basic
18 122033 RK	MR	Multiple Residential	SFR-Basic
18 122045 RK	MR	Multiple Residential	SFR-Basic
18 122057 RK	MR	Multiple Residential	SFR-Basic
18 122043 RK	MR	Multiple Residential	SFR-Basic
18 122055 RK	MR	Multiple Residential	SFR-Basic
18 122053 RK	MR	Multiple Residential	SFR-Basic
18 122044 RK	MR	Multiple Residential	SFR-Basic
18 121878 RK	MR	Multiple Residential	SFR-Basic
18 121883 RK	MR	Multiple Residential	SFR-Basic
18 121887 RK	MR	Multiple Residential	SFR-Basic
18 121891 RK	MR	Multiple Residential	SFR-Basic
18 122063 RK	MR	Multiple Residential	SFR-Basic
18 122035 RK	MR	Multiple Residential	SFR-Basic
18 122038 RK	MR	Multiple Residential	SFR-Basic
18 121095 RK	MR	Multiple Residential	SFR-Basic
18 118547 RK	MR	Multiple Residential	SFR-Basic
18 118548 RK	MR	Multiple Residential	SFR-Basic
18 118536 RK	MR	Multiple Residential	SFR-Basic
18 118535 RK	MR	Multiple Residential	SFR-Basic
18 118549 RK	MR	Multiple Residential	SFR-Basic
18 118534 RK	MR	Multiple Residential	SFR-Basic
18 118546 RK	MR	Multiple Residential	SFR-Basic
18 118533 RK	MR	Multiple Residential	SFR-Basic
18 115083 RK	R-5	Rural-5 Acre	SFR-Basic
18 122690 RK	LDMR	Low Density Multiple Reside	SFR-Basic
18 122691 RK	LDMR	Low Density Multiple Reside	SFR-Basic
18 122695 RK	LDMR	Low Density Multiple Reside	SFR-Basic
18 123247 RK	LDMR	Low Density Multiple Reside	SFR-Basic
18 122696 RK	LDMR	Low Density Multiple Reside	SFR-Basic
18 122785 RK	LDMR	Low Density Multiple Reside	SFR-Basic
18 122697 RK	LDMR	Low Density Multiple Reside	SFR-Basic
18 122698 RK	LDMR	Low Density Multiple Reside	SFR-Basic
18 116130 RK	PRD-20,000(M	Residential 20,000 sq. ft.	Single Family Residential
18 121021 RK	R-7,200	Residential 7,200 sq. ft.	SFR-Basic
18 120884 RK	R-7,200	Residential 7,200 sq. ft.	Single Family Residential
18 121022 RK	R-7,200	Residential 7,200 sq. ft.	SFR-Basic
18 121024 RK	R-7,200	Residential 7,200 sq. ft.	SFR-Basic
18 123233 RK	R-5	Rural-5 Acre	SFR-Basic
18 123242 RK	R-5	Rural-5 Acre	SFR-Basic
18 123234 RK	R-5	Rural-5 Acre	SFR-Basic
18 123235 RK	R-5	Rural-5 Acre	SFR-Basic

Accessory Dwelling Units

Index # - File Name: 1.0022 - Single Family Dwellings Data\_Snohomish County.pdf

18 123236 RK	R-5	Rural-5 Acre	SFR-Basic
18 123237 RK	R-5	Rural-5 Acre	SFR-Basic
18 123240 RK	R-5	Rural-5 Acre	SFR-Basic
18 123238 RK	R-5	Rural-5 Acre	SFR-Basic
18 123239 RK	R-5	Rural-5 Acre	SFR-Basic
18 123241 RK	R-5	Rural-5 Acre	SFR-Basic
18 123244 RK	R-5	Rural-5 Acre	SFR-Basic
18 118530 RK	LDMR : PCB : F	Low Density Multiple Reside	SFR-Basic
18 118529 RK	LDMR : PCB : F	Low Density Multiple Reside	SFR-Basic
18 118457 RK	LDMR : PCB : F	Low Density Multiple Reside	SFR-Basic
18 120010 RK	LDMR : PCB : F	Low Density Multiple Reside	SFR-Basic
18 118478 RK	LDMR : PCB : F	Low Density Multiple Reside	SFR-Basic
18 118475 RK	LDMR : PCB : F	Low Density Multiple Reside	SFR-Basic
18 118480 RK	LDMR : PCB : F	Low Density Multiple Reside	SFR-Basic
18 118471 RK	LDMR : PCB : F	Low Density Multiple Reside	SFR-Basic
18 118481 RK	LDMR : PCB : F	Low Density Multiple Reside	SFR-Basic
18 118482 RK	LDMR : PCB : F	Low Density Multiple Reside	SFR-Basic
18 118483 RK	LDMR : PCB : F	Low Density Multiple Reside	SFR-Basic
18 118485 RK	LDMR : PCB : F	Low Density Multiple Reside	SFR-Basic
18 118486 RK	LDMR : PCB : F	Low Density Multiple Reside	SFR-Basic
18 118492 RK	LDMR : PCB : F	Low Density Multiple Reside	SFR-Basic
18 118494 RK	LDMR : PCB : F	Low Density Multiple Reside	SFR-Basic
18 118496 RK	LDMR : PCB : F	Low Density Multiple Reside	SFR-Basic
18 118498 RK	LDMR : PCB : F	Low Density Multiple Reside	SFR-Basic
18 118513 RK	LDMR : PCB : F	Low Density Multiple Reside	SFR-Basic
18 118531 RK	LDMR : PCB : F	Low Density Multiple Reside	SFR-Basic
18 118514 RK	LDMR : PCB : F	Low Density Multiple Reside	SFR-Basic
18 118521 RK	LDMR : PCB : F	Low Density Multiple Reside	SFR-Basic
18 118522 RK	LDMR : PCB : F	Low Density Multiple Reside	SFR-Basic
18 118523 RK	LDMR : PCB : F	Low Density Multiple Reside	SFR-Basic
18 118524 RK	LDMR : PCB : F	Low Density Multiple Reside	SFR-Basic
18 118525 RK	LDMR : PCB : F	Low Density Multiple Reside	SFR-Basic
18 117875 RK	BP : MR	Business Park : Multiple Resi	SFR-Basic
18 117876 RK	BP : MR	Business Park : Multiple Resi	SFR-Basic
18 117878 RK	BP : MR	Business Park : Multiple Resi	SFR-Basic
18 117877 RK	BP : MR	Business Park : Multiple Resi	SFR-Basic
18 117879 RK	BP : MR	Business Park : Multiple Resi	SFR-Basic
18 117880 RK	BP : MR	Business Park : Multiple Resi	SFR-Basic
18 117881 RK	BP : MR	Business Park : Multiple Resi	SFR-Basic
18 117882 RK	BP : MR	Business Park : Multiple Resi	SFR-Basic
18 118572 RK	R-7,200(PRD)	Residential 7,200 sq. ft.	SFR-Basic
18 121723 RK	R-7,200(PRD)	Residential 7,200 sq. ft.	SFR-Basic
18 122965 RK	R-7,200(PRD)	Residential 7,200 sq. ft.	SFR-Basic
18 118568 RK	R-7,200(PRD)	Residential 7,200 sq. ft.	SFR-Basic
18 118557 RK	R-7,200(PRD)	Residential 7,200 sq. ft.	SFR-Basic
18 119908 RK	R-7,200(PRD)	Residential 7,200 sq. ft.	SFR-Basic
18 124209 RK	R-7,200(PRD)	Residential 7,200 sq. ft.	SFR-Basic

Accessory Dwelling Units

Index # - File Name: 1.0022 - Single Family Dwellings Data\_Snohomish County.pdf

18 121720 RK	R-7,200(PRD)	Residential 7,200 sq. ft.	SFR-Basic
18 122093 RK	R-7,200(PRD)	Residential 7,200 sq. ft.	SFR-Basic
18 122094 RK	R-7,200(PRD)	Residential 7,200 sq. ft.	SFR-Basic
18 118566 RK	R-7,200(PRD)	Residential 7,200 sq. ft.	SFR-Basic
18 120410 RK	R-7,200(PRD)	Residential 7,200 sq. ft.	SFR-Basic
18 118797 RK	R-7,200(PRD)	Residential 7,200 sq. ft.	SFR-Basic
18 119909 RK	R-7,200(PRD)	Residential 7,200 sq. ft.	SFR-Basic
18 125503 RK	R-7,200(PRD)	Residential 7,200 sq. ft.	SFR-Basic
18 120683 RK	R-7,200(PRD)	Residential 7,200 sq. ft.	SFR-Basic
18 122095 RK	R-7,200(PRD)	Residential 7,200 sq. ft.	SFR-Basic
18 119916 RK	R-7,200(PRD)	Residential 7,200 sq. ft.	SFR-Basic
18 119918 RK	R-7,200(PRD)	Residential 7,200 sq. ft.	SFR-Basic
18 119933 RK	R-7,200(PRD)	Residential 7,200 sq. ft.	SFR-Basic
18 118798 RK	R-7,200(PRD)	Residential 7,200 sq. ft.	SFR-Basic
18 118811 RK	R-7,200(PRD)	Residential 7,200 sq. ft.	SFR-Basic
18 119296 RK	R-7,200(PRD)	Residential 7,200 sq. ft.	SFR-Basic
18 118555 RK	R-7,200(PRD)	Residential 7,200 sq. ft.	SFR-Basic
18 118573 RK	R-7,200(PRD)	Residential 7,200 sq. ft.	SFR-Basic
18 118570 RK	R-7,200(PRD)	Residential 7,200 sq. ft.	SFR-Basic
18 119365 RK	R-7,200(PRD)	Residential 7,200 sq. ft.	SFR-Basic
18 118569 RK	R-7,200(PRD)	Residential 7,200 sq. ft.	SFR-Basic
18 118571 RK	R-7,200(PRD)	Residential 7,200 sq. ft.	SFR-Basic
18 123245 RK	R-5	Rural-5 Acre	SFR-Basic
18 123246 RK	R-5	Rural-5 Acre	SFR-Basic
18 118278 RK	R-5	Rural-5 Acre	Single Family Residential
18 118281 RK	R-5	Rural-5 Acre	Single Family Residential
18 117415 RK	R-5	Rural-5 Acre	Single Family Residential
18 121408 RK	R-5	Rural-5 Acre	SFR-Basic
18 121412 RK	R-5	Rural-5 Acre	SFR-Basic
18 117873 RK	R-5	Rural-5 Acre	SFR-Basic
18 121413 RK	R-5	Rural-5 Acre	SFR-Basic
18 121430 RK	R-5	Rural-5 Acre	SFR-Basic
18 121432 RK	R-5	Rural-5 Acre	SFR-Basic
18 121439 RK	R-5	Rural-5 Acre	SFR-Basic
18 117549 RK	R-5	Rural-5 Acre	SFR-Basic
18 121440 RK	R-5	Rural-5 Acre	SFR-Basic
18 117563 RK	R-5	Rural-5 Acre	SFR-Basic
18 117562 RK	R-5	Rural-5 Acre	SFR-Basic
18 117565 RK	R-5	Rural-5 Acre	SFR-Basic
18 117740 RK	R-5	Rural-5 Acre	Single Family Residential
18 117743 RK	R-5	Rural-5 Acre	Single Family Residential
18 126255 RK	MR	Multiple Residential	SFR-Basic
18 123196 RK	MR	Multiple Residential	SFR-Basic
18 123195 RK	MR	Multiple Residential	SFR-Basic
18 125210 RK	MR	Multiple Residential	SFR-Basic
18 125212 RK	MR	Multiple Residential	SFR-Basic
18 123193 RK	MR	Multiple Residential	SFR-Basic

Accessory Dwelling Units

Index # - File Name: 1.0022 - Single Family Dwellings Data\_Snohomish County.pdf

18 123194 RK	MR	Multiple Residential	SFR-Basic
18 119060 RK	F	Forestry	Single Family Residential
18 120327 RK	LDMR	Low Density Multiple Reside	SFR-Basic
18 120320 RK	LDMR	Low Density Multiple Reside	SFR-Basic
18 120115 RK	LDMR	Low Density Multiple Reside	SFR-Basic
18 120116 RK	LDMR	Low Density Multiple Reside	SFR-Basic
18 120117 RK	LDMR	Low Density Multiple Reside	SFR-Basic
18 120119 RK	LDMR	Low Density Multiple Reside	SFR-Basic
18 118692 RK	R-9,600	Residential 9,600 sq. ft.	Single Family Residential
18 118751 RK	R-5	Rural-5 Acre	Single Family Residential
18 121409 RK	LDMR	Low Density Multiple Reside	SFR-Basic
18 121806 RK	LDMR	Low Density Multiple Reside	SFR-Basic
18 121857 RK	LDMR	Low Density Multiple Reside	SFR-Basic
18 121810 RK	LDMR	Low Density Multiple Reside	SFR-Basic
18 121084 RK	LDMR	Low Density Multiple Reside	SFR-Basic
18 121085 RK	LDMR	Low Density Multiple Reside	SFR-Basic
18 121083 RK	LDMR	Low Density Multiple Reside	SFR-Basic
18 120965 RK	LDMR	Low Density Multiple Reside	SFR-Basic
18 121032 RK	LDMR	Low Density Multiple Reside	SFR-Basic
18 120960 RK	LDMR	Low Density Multiple Reside	SFR-Basic
18 121082 RK	LDMR	Low Density Multiple Reside	SFR-Basic
18 121086 RK	LDMR	Low Density Multiple Reside	SFR-Basic
18 123192 RK	MR	Multiple Residential	SFR-Basic
18 118071 RK	R-5	Rural-5 Acre	SFR-Basic
18 118327 MH	R-5	Rural-5 Acre	Double Wide
18 118201 RK	R-7,200	Residential 7,200 sq. ft.	Single Family Residential
18 118200 RK	R-7,200	Residential 7,200 sq. ft.	Single Family Residential
18 120469 MH	F	Forestry	Double Wide
18 120476 MH	F	Forestry	Double Wide
18 120481 MH	F	Forestry	Double Wide
18 120673 RK	R-7,200	Residential 7,200 sq. ft.	Accessory Apt Detached
18 118643 RK	R-5	Rural-5 Acre	Single Family Residential
18 121927 RK	R-5	Rural-5 Acre	Single Family Residential
18 124914 RK	R-5	Rural-5 Acre	SFR-Basic
18 122396 RK	R-5	Rural-5 Acre	SFR-Basic
18 122394 RK	R-5	Rural-5 Acre	SFR-Basic
18 122393 RK	R-5	Rural-5 Acre	SFR-Basic
18 151451 RK	R-7,200(PRD)	Residential 7,200 sq. ft.	SFR-Basic
18 152115 RK	R-7,200(PRD)	Residential 7,200 sq. ft.	SFR-Basic
18 152076 RK	R-7,200(PRD)	Residential 7,200 sq. ft.	SFR-Basic
18 152116 RK	R-7,200(PRD)	Residential 7,200 sq. ft.	SFR-Basic
18 151452 RK	R-7,200(PRD)	Residential 7,200 sq. ft.	SFR-Basic
18 126325 RK	R-7,200	Residential 7,200 sq. ft.	SFR-Basic
18 125283 RK	R-7,200	Residential 7,200 sq. ft.	SFR-Basic
18 125282 RK	R-7,200	Residential 7,200 sq. ft.	SFR-Basic
18 126326 RK	R-7,200	Residential 7,200 sq. ft.	SFR-Basic
18 127286 RK	R-7,200	Residential 7,200 sq. ft.	SFR-Basic

Accessory Dwelling Units

Index # - File Name: 1.0022 - Single Family Dwellings Data\_Snohomish County.pdf

18 127032 RK	R-7,200	Residential 7,200 sq. ft.	SFR-Basic
18 127034 RK	R-7,200	Residential 7,200 sq. ft.	SFR-Basic
18 127025 RK	R-7,200	Residential 7,200 sq. ft.	SFR-Basic
18 127970 RK	R-7,200	Residential 7,200 sq. ft.	SFR-Basic
18 127969 RK	R-7,200	Residential 7,200 sq. ft.	SFR-Basic
18 127967 RK	R-7,200	Residential 7,200 sq. ft.	SFR-Basic
18 125562 RK	R-7,200	Residential 7,200 sq. ft.	SFR-Basic
18 125549 RK	R-7,200	Residential 7,200 sq. ft.	SFR-Basic
18 125547 RK	R-7,200	Residential 7,200 sq. ft.	SFR-Basic
18 125546 RK	R-7,200	Residential 7,200 sq. ft.	SFR-Basic
18 126327 RK	R-7,200	Residential 7,200 sq. ft.	SFR-Basic
18 126328 RK	R-7,200	Residential 7,200 sq. ft.	SFR-Basic
18 127030 RK	R-7,200	Residential 7,200 sq. ft.	SFR-Basic
18 126986 RK	R-7,200	Residential 7,200 sq. ft.	SFR-Basic
18 126985 RK	R-7,200	Residential 7,200 sq. ft.	SFR-Basic
18 125955 RK	R-7,200	Residential 7,200 sq. ft.	SFR-Basic
18 125280 RK	R-7,200	Residential 7,200 sq. ft.	SFR-Basic
18 127862 RK	LDMR	Low Density Multiple Reside	SFR-Basic
18 127865 RK	LDMR	Low Density Multiple Reside	SFR-Basic
18 127870 RK	LDMR	Low Density Multiple Reside	SFR-Basic
18 127875 RK	LDMR	Low Density Multiple Reside	SFR-Basic
18 127877 RK	LDMR	Low Density Multiple Reside	SFR-Basic
18 125336 RK	R-5	Rural-5 Acre	SFR-Basic
18 125046 RK	R-5	Rural-5 Acre	SFR-Basic
18 118303 RK	R-7,200	Residential 7,200 sq. ft.	Single Family Residential
18 101138 RK	R-5	Rural-5 Acre	SFR-Basic
18 116330 RK	R-5	Rural-5 Acre	Single Family Residential
18 115034 RK	R-5	Rural-5 Acre	Single Family Residential
17 118449 RK	R-5	Rural-5 Acre	SFR-Basic
17 118450 RK	R-5	Rural-5 Acre	SFR-Basic
18 100592 RK	R-5	Rural-5 Acre	Single Family Residential
17 119032 RK	R-5	Rural-5 Acre	Single Family Residential
18 113169 RK	R-5	Rural-5 Acre	Single Family Residential
18 116832 RK	R-5	Rural-5 Acre	Single Family Residential
18 116301 RK	R-5	Rural-5 Acre	Single Family Residential
18 120612 RK	R-5	Rural-5 Acre	Single Family Residential
18 113165 RK	R-5	Rural-5 Acre	Single Family Residential
17 118173 RK	R-5	Rural-5 Acre	Single Family Residential
16 122004 RK	MR	Multiple Residential	Single Family Residential
16 122003 RK	MR	Multiple Residential	Duplex
18 114098 RK	R-5	Rural-5 Acre	Single Family Residential
18 119190 RK	R-5	Rural-5 Acre	Single Family Residential
18 121325 RK	R-5	Rural-5 Acre	Single Family Residential
18 116420 RK	R-5 : RC	Rural Conservation : Rural-5	Single Family Residential
18 100136 RK	R-7,200	Residential 7,200 sq. ft.	SFR-Basic
18 100137 RK	R-7,200	Residential 7,200 sq. ft.	SFR-Basic
17 105890 RK	F	Forestry	SFR-Basic

Accessory Dwelling Units

Index # - File Name: 1.0022 - Single Family Dwellings Data\_Snohomish County.pdf

18 112020 000 01 RK	R-5	Rural-5 Acre	Single Family Residential
17 105903 RK	F	Forestry	SFR-Basic
17 114455 RK	F	Forestry	SFR-Basic
17 105885 RK	F	Forestry	SFR-Basic
17 105900 RK	F	Forestry	SFR-Basic
18 116685 RK	R-7,200	Residential 7,200 sq. ft.	Single Family Residential
18 116179 RK	R-7,200	Residential 7,200 sq. ft.	Single Family Residential
18 120150 RK	R-5	Rural-5 Acre	Single Family Residential
17 119339 RK	R-9,600	Residential 9,600 sq. ft.	Single Family Residential
18 100083 RK	R-9,600	Residential 9,600 sq. ft.	Single Family Residential
17 119430 RK	R-5	Rural-5 Acre	SFR-Basic
17 119433 RK	R-5	Rural-5 Acre	SFR-Basic
18 127966 RK	R-5	Rural-5 Acre	SFR-Basic
18 100076 RK	R-9,600	Residential 9,600 sq. ft.	Single Family Residential
18 100079 RK	R-9,600	Residential 9,600 sq. ft.	Single Family Residential
18 101324 RK	R-9,600	Residential 9,600 sq. ft.	Single Family Residential
18 116924 RK	R-9,600	Residential 9,600 sq. ft.	Single Family Residential
18 126979 RK	R-5	Rural-5 Acre	SFR-Basic
18 126980 RK	R-5	Rural-5 Acre	SFR-Basic
18 126982 RK	R-5	Rural-5 Acre	SFR-Basic
18 126981 RK	R-5	Rural-5 Acre	SFR-Basic
18 126983 RK	R-5	Rural-5 Acre	SFR-Basic
18 116215 RK	R-5	Rural-5 Acre	SFR-Basic
18 112842 RK	R-5	Rural-5 Acre	SFR-Basic
18 117115 RK	R-5	Rural-5 Acre	Single Family Residential
18 120346 RK	R-5	Rural-5 Acre	SFR-Basic
18 112098 RK	R-5	Rural-5 Acre	SFR-Basic
18 120345 RK	R-5	Rural-5 Acre	SFR-Basic
18 113442 RK	R-5	Rural-5 Acre	Single Family Residential
17 119656 RK	R-5	Rural-5 Acre	SFR-Basic
18 111901 RK	R-5	Rural-5 Acre	SFR-Basic
18 101019 RK	R-5	Rural-5 Acre	SFR-Basic
18 111916 RK	R-5	Rural-5 Acre	SFR-Basic
18 114444 RK	R-5	Rural-5 Acre	SFR-Basic
18 114456 RK	R-5	Rural-5 Acre	SFR-Basic
18 114866 RK	R-5	Rural-5 Acre	SFR-Basic
18 114868 RK	R-5	Rural-5 Acre	SFR-Basic
18 115579 RK	R-5	Rural-5 Acre	SFR-Basic
18 114886 RK	R-5	Rural-5 Acre	SFR-Basic
18 114870 RK	R-5	Rural-5 Acre	SFR-Basic
18 121802 RK	R-5	Rural-5 Acre	Single Family Residential
18 122418 RK	R-5	Rural-5 Acre	Single Family Residential
18 122694 RK	R-5	Rural-5 Acre	SFR-Basic
18 101881 MH	R-5	Rural-5 Acre	Triple Wide
17 116762 RK	R-9,600	Residential 9,600 sq. ft.	Single Family Residential
17 118319 RK	R-5	Rural-5 Acre	SFR-Basic
18 113381 RK	R-5	Rural-5 Acre	Single Family Residential

Accessory Dwelling Units

Index # - File Name: 1.0022 - Single Family Dwellings Data\_Snohomish County.pdf

18 100830 RK	R-5	Rural-5 Acre	SFR-Basic
18 100837 RK	R-5	Rural-5 Acre	SFR-Basic
18 120752 RK	R-5	Rural-5 Acre	SFR-Basic
18 112378 RK	R-8,400	Residential 8,400 sq. ft.	Single Family Residential
18 118169 RK	R-7,200	Residential 7,200 sq. ft.	Single Family Residential
18 118168 RK	R-7,200	Residential 7,200 sq. ft.	Single Family Residential
18 118167 RK	R-7,200	Residential 7,200 sq. ft.	Single Family Residential
18 115731 RK	R-5	Rural-5 Acre	SFR-Basic
18 115729 RK	R-5	Rural-5 Acre	SFR-Basic
16 105265 RK	R-5	Rural-5 Acre	Single Family Residential
18 101031 RK	LDMR	Low Density Multiple Reside	Single Family Residential
18 101027 RK	LDMR	Low Density Multiple Reside	Single Family Residential
18 101033 RK	LDMR	Low Density Multiple Reside	Single Family Residential
18 114878 RK	R-5	Rural-5 Acre	Accessory Apt Detached
18 119934 RK	R-5	Rural-5 Acre	Accessory Apt Detached
18 119255 RK	R-5	Rural-5 Acre	Single Family Residential
18 112817 000 01 RK	R-9,600	Residential 9,600 sq. ft.	Single Family Residential
17 109698 RK	R-7,200 : R-8,4	Residential 7,200 sq. ft. : Res	SFR-Basic
17 112429 RK	MR	Multiple Residential	SFR-Basic
17 114483 RK	R-5	Rural-5 Acre	Single Family Residential
17 116763 RK	R-5	Rural-5 Acre	Single Family Residential
17 119523 RK	R-5	Rural-5 Acre	Single Family Residential
18 100391 RK	R-5	Rural-5 Acre	Single Family Residential
18 100389 RK	R-5	Rural-5 Acre	Single Family Residential
17 117301 RK	R-5	Rural-5 Acre	Single Family Residential
18 100661 RK	R-5	Rural-5 Acre	Single Family Residential
18 112225 RK	R-5	Rural-5 Acre	Single Family Residential
18 120656 RK	R-7,200(PRD)	Residential 7,200 sq. ft.	SFR-Basic
18 119361 RK	R-7,200(PRD)	Residential 7,200 sq. ft.	SFR-Basic
18 120255 RK	R-7,200(PRD)	Residential 7,200 sq. ft.	SFR-Basic
18 120657 RK	R-7,200(PRD)	Residential 7,200 sq. ft.	SFR-Basic
18 122632 RK	R-7,200(PRD)	Residential 7,200 sq. ft.	SFR-Basic
18 122391 RK	R-7,200(PRD)	Residential 7,200 sq. ft.	SFR-Basic
18 116081 RK	R-7,200(PRD)	Residential 7,200 sq. ft.	SFR-Basic
18 116204 RK	R-7,200(PRD)	Residential 7,200 sq. ft.	SFR-Basic
18 117179 000 01 RK	R-5	Rural-5 Acre	Single Family Residential
18 118044 000 01 RK	R-5	Rural-5 Acre	Single Family Residential
18 121985 RK	R-5	Rural-5 Acre	Single Family Residential
18 113635 RK	R-5	Rural-5 Acre	SFR-Basic
18 112253 RK	R-5	Rural-5 Acre	SFR-Basic
18 111979 RK	R-5	Rural-5 Acre	SFR-Basic
18 111984 RK	R-5	Rural-5 Acre	Single Family Residential
18 111955 RK	R-5	Rural-5 Acre	SFR-Basic
18 113656 RK	R-5	Rural-5 Acre	SFR-Basic
18 113665 RK	R-5	Rural-5 Acre	SFR-Basic
18 118058 RK	R-5	Rural-5 Acre	SFR-Basic
18 112256 RK	R-5	Rural-5 Acre	SFR-Basic



Accessory Dwelling Units

Index # - File Name: 1.0022 - Single Family Dwellings Data\_Snohomish County.pdf

17 102016 RK	R-5	Rural-5 Acre	SFR-Basic
17 102022 RK	R-5	Rural-5 Acre	SFR-Basic
17 102024 RK	R-5	Rural-5 Acre	SFR-Basic
17 101947 000 01 RK	R-9,600	Residential 9,600 sq. ft.	Single Family Residential
18 100693 RK	R-7,200(PRD)	Residential 7,200 sq. ft.	Single Family Residential
17 103695 RK	R-5	Rural-5 Acre	Single Family Residential
17 103696 RK	R-5	Rural-5 Acre	Single Family Residential
17 105825 RK	R-5	Rural-5 Acre	Single Family Residential
18 117114 RK	R-5	Rural-5 Acre	SFR-Basic
18 117122 RK	R-5	Rural-5 Acre	SFR-Basic
18 117129 RK	R-5	Rural-5 Acre	SFR-Basic
18 117216 RK	R-5	Rural-5 Acre	SFR-Basic
18 117131 RK	R-5	Rural-5 Acre	SFR-Basic
18 117221 RK	R-5	Rural-5 Acre	SFR-Basic
18 120176 RK	R-5	Rural-5 Acre	SFR-Basic
18 115824 RK	R-5	Rural-5 Acre	Single Family Residential
18 101309 000 01 RK	R-5	Rural-5 Acre	Single Family Residential
18 121892 RK	R-9,600	Residential 9,600 sq. ft.	Single Family Residential
17 107216 RK	R-5	Rural-5 Acre	Single Family Residential
18 122258 RK	F	Forestry	Single Family Residential
17 110418 RK	R-7,200	Residential 7,200 sq. ft.	Single Family Residential
17 118901 RK	R-7,200	Residential 7,200 sq. ft.	Single Family Residential
17 117774 RK	R-7,200	Residential 7,200 sq. ft.	Single Family Residential
17 117775 RK	R-7,200	Residential 7,200 sq. ft.	Single Family Residential
17 118997 RK	R-7,200	Residential 7,200 sq. ft.	Single Family Residential
17 117779 RK	R-7,200	Residential 7,200 sq. ft.	Single Family Residential
17 119636 RK	R-7,200	Residential 7,200 sq. ft.	Single Family Residential
17 117797 RK	R-7,200	Residential 7,200 sq. ft.	Single Family Residential
17 118996 RK	R-7,200	Residential 7,200 sq. ft.	Single Family Residential
17 119637 RK	R-7,200	Residential 7,200 sq. ft.	Single Family Residential
17 117769 RK	R-7,200	Residential 7,200 sq. ft.	Single Family Residential
18 123833 000 01 RK	R-5	Rural-5 Acre	Single Family Residential
17 119639 RK	R-7,200	Residential 7,200 sq. ft.	Single Family Residential
17 117771 RK	R-7,200	Residential 7,200 sq. ft.	Single Family Residential
17 119802 RK	R-7,200	Residential 7,200 sq. ft.	Single Family Residential
17 117796 RK	R-7,200	Residential 7,200 sq. ft.	Single Family Residential
17 119803 RK	R-7,200	Residential 7,200 sq. ft.	Single Family Residential
17 110845 RK	R-5	Rural-5 Acre	Single Family Residential
18 101127 MH	R-5	Rural-5 Acre	Double Wide
18 101987 RK	R-5	Rural-5 Acre	Single Family Residential
18 118413 RK	R-5	Rural-5 Acre	Single Family Residential
18 118411 RK	R-5	Rural-5 Acre	Single Family Residential
18 118414 RK	R-5	Rural-5 Acre	Single Family Residential
18 115570 RK	R-5	Rural-5 Acre	Single Family Residential
18 118310 RK	R-5	Rural-5 Acre	Single Family Residential
18 118056 RK	R-5	Rural-5 Acre	Single Family Residential
18 114500 RK	R-5	Rural-5 Acre	Single Family Residential

Accessory Dwelling Units

Index # - File Name: 1.0022 - Single Family Dwellings Data\_Snohomish County.pdf

18 116969 RK	R-5	Rural-5 Acre	Single Family Residential
18 113970 RK	R-5	Rural-5 Acre	SFR-Basic
18 113981 RK	R-5	Rural-5 Acre	SFR-Basic
18 113799 RK	F	Forestry	Single Family Residential
18 111794 RK	R-5	Rural-5 Acre	Single Family Residential
18 111792 RK	R-5	Rural-5 Acre	Single Family Residential
18 123340 RK	R-5	Rural-5 Acre	Single Family Residential
18 117642 RK	R-5	Rural-5 Acre	Single Family Residential
18 119249 RK	R-5	Rural-5 Acre	Single Family Residential
18 123349 RK	R-5	Rural-5 Acre	Single Family Residential
18 101492 RK	R-5	Rural-5 Acre	Single Family Residential
18 126662 RK	R-5	Rural-5 Acre	Single Family Residential
17 116837 RK	R-5	Rural-5 Acre	Single Family Residential
17 110648 RK	R-5	Rural-5 Acre	Single Family Residential
18 111924 RK	R-5	Rural-5 Acre	Single Family Residential
17 119323 RK	R-5	Rural-5 Acre	Single Family Residential
17 113667 RK	R-5	Rural-5 Acre	Single Family Residential
17 111462 000 01 RK	R-5	Rural-5 Acre	Single Family Residential
18 123769 RK	R-5	Rural-5 Acre	Single Family Residential
18 113764 000 01 RK	R-5	Rural-5 Acre	Single Family Residential
18 115074 RK	R-5	Rural-5 Acre	Single Family Residential
18 122924 RK	R-5	Rural-5 Acre	SFR-Basic
18 122380 RK	R-5	Rural-5 Acre	SFR-Basic
18 114709 RK	R-5	Rural-5 Acre	SFR-Basic
18 114708 RK	R-5	Rural-5 Acre	SFR-Basic
18 114727 RK	R-5	Rural-5 Acre	SFR-Basic
18 122381 RK	R-5	Rural-5 Acre	SFR-Basic
18 101107 RK	R-5	Rural-5 Acre	SFR-Basic
18 114707 RK	R-5	Rural-5 Acre	SFR-Basic
18 122367 RK	R-5	Rural-5 Acre	SFR-Basic
18 114705 RK	R-5	Rural-5 Acre	SFR-Basic
18 122641 RK	R-5	Rural-5 Acre	Single Family Residential
17 109703 RK	R-5	Rural-5 Acre	Single Family Residential
17 116329 RK	R-5	Rural-5 Acre	Single Family Residential
18 117325 RK	A-10	Agriculture-10 Acre	Single Family Residential
17 118109 000 01 RK	R-5	Rural-5 Acre	Single Family Residential
18 112396 RK	R-9,600	Residential 9,600 sq. ft.	Single Family Residential
18 114950 RK	R-5	Rural-5 Acre	Accessory Apt Detached
17 112106 RK	A-10	Agriculture-10 Acre	Single Family Residential
18 120173 RK	R-5	Rural-5 Acre	Single Family Residential
18 112508 RK	A-10 : CITY	Agriculture-10 Acre : City	Single Family Residential
17 108076 RK	R-5	Rural-5 Acre	Single Family Residential
18 113688 MH	R-5	Rural-5 Acre	Double Wide
18 116901 RK	R-5	Rural-5 Acre	Accessory Apt Detached
18 120758 RK	R-5	Rural-5 Acre	Single Family Residential
18 118052 000 01 RK	R-5	Rural-5 Acre	Single Family Residential
17 107978 RK	RRT-10	Rural Resource Transition-10	Single Family Residential

Accessory Dwelling Units

Index # - File Name: 1.0022 - Single Family Dwellings Data\_Snohomish County.pdf

18 120741 RK	R-7,200	Residential 7,200 sq. ft.	Single Family Residential
18 123711 MH	RD	Rural Diversification	Mobile/Manufactured Home
18 111854 RK	R-5	Rural-5 Acre	Single Family Residential
18 124208 RK	R-5	Rural-5 Acre	SFR-Basic
18 113018 RK	R-5	Rural-5 Acre	Single Family Residential
18 119354 RK	R-5	Rural-5 Acre	Single Family Residential
18 119371 RK	R-5	Rural-5 Acre	SFR-Basic
18 100219 RK	R-5	Rural-5 Acre	Single Family Residential
18 119374 RK	R-5	Rural-5 Acre	SFR-Basic
18 120546 RK	R-5	Rural-5 Acre	Single Family Residential
18 114079 RK	R-5	Rural-5 Acre	Single Family Residential
17 107836 000 01 RK	R-9,600	Residential 9,600 sq. ft.	Single Family Residential
18 115837 RK	R-9,600	Residential 9,600 sq. ft.	Single Family Residential
18 115523 RK	R-9,600	Residential 9,600 sq. ft.	Single Family Residential
18 114108 RK	R-5	Rural-5 Acre	Single Family Residential
18 117688 RK	R-9,600	Residential 9,600 sq. ft.	Accessory Apt Detached
17 119908 000 01 RK	R-5	Rural-5 Acre	Single Family Residential
18 115132 RK	R-5	Rural-5 Acre	Single Family Residential
18 120121 RK	R-5	Rural-5 Acre	Single Family Residential
18 120125 RK	R-5	Rural-5 Acre	Single Family Residential
18 113584 RK	A-10	Agriculture-10 Acre	Single Family Residential
17 114461 RK	R-5	Rural-5 Acre	Single Family Residential
18 112402 RK	R-5	Rural-5 Acre	Single Family Residential
18 122472 RK	R-5	Rural-5 Acre	Single Family Residential
18 117869 RK	R-5	Rural-5 Acre	Single Family Residential
18 113300 RK	R-5	Rural-5 Acre	Single Family Residential
18 120810 RK	R-5	Rural-5 Acre	Single Family Residential
17 119381 MH	R-5	Rural-5 Acre	Double Wide
18 121642 MH	R-5	Rural-5 Acre	Triple Wide
18 119262 MH	R-5	Rural-5 Acre	Triple Wide
18 117275 RK	R-5	Rural-5 Acre	Single Family Residential
18 114912 RK	R-5	Rural-5 Acre	Single Family Residential
17 105906 RK	F : R-5	Forestry : Rural-5 Acre	SFR-Basic
18 121747 RK	F	Forestry	Accessory Apt Detached
18 126363 RK	A-10	Agriculture-10 Acre	Single Family Residential
18 118273 RK	R-5	Rural-5 Acre	Single Family Residential
18 122762 RK	R-5	Rural-5 Acre	Single Family Residential
17 118227 RK	R-5	Rural-5 Acre	Single Family Residential
17 114442 RK	MR	Multiple Residential	Duplex
17 110843 RK	R-5	Rural-5 Acre	Single Family Residential
18 117903 RK	R-5	Rural-5 Acre	Single Family Residential
18 118694 RK	R-5	Rural-5 Acre	Single Family Residential
18 114483 000 01 RK	R-5	Rural-5 Acre	Single Family Residential
18 101831 RK	R-5	Rural-5 Acre	Single Family Residential
18 101875 RK	R-5	Rural-5 Acre	Single Family Residential
18 101445 RK	R-5	Rural-5 Acre	Single Family Residential
17 118474 RK	R-5	Rural-5 Acre	Single Family Residential

Accessory Dwelling Units

Index # - File Name: 1.0022 - Single Family Dwellings Data\_Snohomish County.pdf

17 117157 RK	R-5	Rural-5 Acre	Single Family Residential
18 122365 RK	R-9,600	Residential 9,600 sq. ft.	Duplex
18 114025 000 01 RK	LDMR	Low Density Multiple Reside	Single Family Residential
17 119403 000 01 RK	R-8,400	Residential 8,400 sq. ft.	Duplex
18 113902 RK	LDMR	Low Density Multiple Reside	Duplex
18 114755 RK	R-5	Rural-5 Acre	Single Family Residential
18 113842 MH	R-5	Rural-5 Acre	Double Wide
18 121173 RK	R-5	Rural-5 Acre	Single Family Residential
18 115506 RK	R-5	Rural-5 Acre	Single Family Residential
18 120441 RK	R-5	Rural-5 Acre	Single Family Residential
18 113423 RK	R-8,400	Residential 8,400 sq. ft.	Accessory Apt Detached
18 111915 RK	R-8,400	Residential 8,400 sq. ft.	Duplex
18 118607 RK	R-9,600	Residential 9,600 sq. ft.	Duplex
18 100929 RK	R-8,400	Residential 8,400 sq. ft.	Accessory Apt Detached
18 115825 MH	F	Forestry	Mobile/Manufactured Home
17 112825 RK	PRD-20,000(M	Residential 20,000 sq. ft.	Single Family Residential
18 122902 RK	PRD-20,000(M	Residential 20,000 sq. ft.	Single Family Residential
17 117009 RK	R-5	Rural-5 Acre	Single Family Residential
17 117907 RK	R-9,600	Residential 9,600 sq. ft.	Single Family Residential
18 123924 RK	R-9,600	Residential 9,600 sq. ft.	Single Family Residential
18 113972 RK	F	Forestry	Single Family Residential
17 116194 RK	R-9,600	Residential 9,600 sq. ft.	Single Family Residential
18 113422 000 01 RK	R-7,200	Residential 7,200 sq. ft.	Single Family Residential
17 119806 RK	MR	Multiple Residential	Single Family Residential
17 117953 RK	R-5	Rural-5 Acre	SFR-Basic
18 114048 RK	R-5	Rural-5 Acre	Single Family Residential
17 112723 000 01 RK	R-5	Rural-5 Acre	Single Family Residential
17 116620 RK	R-5	Rural-5 Acre	Single Family Residential
17 115360 RK	R-5	Rural-5 Acre	Single Family Residential
18 112204 RK	R-5	Rural-5 Acre	Single Family Residential
18 111948 MH	R-5	Rural-5 Acre	Double Wide
17 108717 RK	R-5	Rural-5 Acre	Single Family Residential
18 118031 RK	R-9,600	Residential 9,600 sq. ft.	Accessory Apt Attached
17 118944 RK	PRD-20,000(M	Residential 20,000 sq. ft.	Single Family Residential
18 115581 RK	R-9,600	Residential 9,600 sq. ft.	Accessory Apt Detached
18 112195 RK	R-5	Rural-5 Acre	Single Family Residential
17 112063 MH	R-5	Rural-5 Acre	Single Wide
18 122477 RK	R-5	Rural-5 Acre	Single Family Residential
18 123304 RK	R-5	Rural-5 Acre	Single Family Residential
17 119945 000 01 RK	R-5	Rural-5 Acre	Single Family Residential
16 111647 RK	R-5	Rural-5 Acre	Single Family Residential
18 100570 RK	R-5	Rural-5 Acre	Single Family Residential
18 119274 RK	R-5	Rural-5 Acre	Single Family Residential
17 118378 RK	R-8,400	Residential 8,400 sq. ft.	Accessory Apt Detached
17 117133 RK	R-5	Rural-5 Acre	Single Family Residential
18 101921 000 01 RK	R-7,200	Residential 7,200 sq. ft.	Duplex
17 118332 000 01 RK	R-7,200	Residential 7,200 sq. ft.	Single Family Residential

Accessory Dwelling Units

Index # - File Name: 1.0022 - Single Family Dwellings Data\_Snohomish County.pdf

18 101384 MH	R-7,200	Residential 7,200 sq. ft.	Double Wide
17 108678 RK	R-5	Rural-5 Acre	Single Family Residential
18 118007 RK	R-5	Rural-5 Acre	Single Family Residential
18 100961 RK	R-5	Rural-5 Acre	Single Family Residential
18 125938 RK	R-5	Rural-5 Acre	Single Family Residential
18 114033 RK	R-5	Rural-5 Acre	Single Family Residential
18 113276 000 01 RK	R-5	Rural-5 Acre	Single Family Residential
18 116622 RK	R-5	Rural-5 Acre	Single Family Residential
17 119724 RK	RRT-10	Rural Resource Transition-10	Single Family Residential
18 117095 RK	RRT-10	Rural Resource Transition-10	Single Family Residential
17 117747 RK	RRT-10	Rural Resource Transition-10	Single Family Residential
18 112904 RK	R-5	Rural-5 Acre	Single Family Residential
17 117163 MH	R-5	Rural-5 Acre	Double Wide
18 122428 MH	R-5	Rural-5 Acre	Mobile/Manufactured Home
17 118279 RK	R-5	Rural-5 Acre	Single Family Residential
18 113528 RK	RRT-10	Rural Resource Transition-10	Single Family Residential
18 119951 RK	R-5	Rural-5 Acre	Single Family Residential
17 116182 RK	R-5	Rural-5 Acre	Single Family Residential
16 114633 000 01 RK	R-5	Rural-5 Acre	Single Family Residential
17 119278 RK	R-5	Rural-5 Acre	Single Family Residential
17 118522 RK	RRT-10	Rural Resource Transition-10	Single Family Residential
17 119375 RK	R-5	Rural-5 Acre	Single Family Residential
15 106910 000 01 RK	R-5	Rural-5 Acre	Single Family Residential
17 112121 RK	RRT-10	Rural Resource Transition-10	Single Family Residential
18 119342 RK	R-5	Rural-5 Acre	Single Family Residential
18 117346 RK	R-5	Rural-5 Acre	Accessory Apt Detached
18 120329 RK	R-5	Rural-5 Acre	Single Family Residential
17 119393 MH	R-5	Rural-5 Acre	Double Wide
18 116431 RK	R-5	Rural-5 Acre	Single Family Residential
18 115545 RK	R-5	Rural-5 Acre	Single Family Residential
18 119057 RK	A-10	Agriculture-10 Acre	Single Family Residential
18 112496 RK	A-10	Agriculture-10 Acre	Single Family Residential
18 100963 RK	R-5	Rural-5 Acre	Single Family Residential
18 114325 RK	R-5	Rural-5 Acre	Single Family Residential
17 109189 000 01 RK	R-5	Rural-5 Acre	Single Family Residential
17 114530 000 01 RK	R-5	Rural-5 Acre	Accessory Apt Detached
18 101067 MH	R-5	Rural-5 Acre	Single Wide
18 118449 RK	R-5	Rural-5 Acre	Single Family Residential
18 114184 RK	R-5	Rural-5 Acre	Single Family Residential
18 115552 RK	R-5	Rural-5 Acre	Single Family Residential
18 117005 MH	R-5	Rural-5 Acre	Double Wide
18 112756 RK	R-5	Rural-5 Acre	Single Family Residential
18 121071 RK	R-5	Rural-5 Acre	Single Family Residential
18 100533 RK	R-5	Rural-5 Acre	Single Family Residential
18 113178 MH	R-5	Rural-5 Acre	Double Wide
18 114966 RK	R-5	Rural-5 Acre	Single Family Residential
17 112544 MH	R-5	Rural-5 Acre	Double Wide

Accessory Dwelling Units

Index # - File Name: 1.0022 - Single Family Dwellings Data\_Snohomish County.pdf

17 119005 RK	R-5	Rural-5 Acre	Single Family Residential
18 113522 MH	R-5	Rural-5 Acre	Double Wide
17 117189 MH	R-5	Rural-5 Acre	Double Wide
17 115098 RK	R-5	Rural-5 Acre	Single Family Residential
18 100453 RK	R-5	Rural-5 Acre	Single Family Residential
18 115900 RK	R-5	Rural-5 Acre	Single Family Residential
18 101091 MH	R-5	Rural-5 Acre	Triple Wide
18 113280 RK	R-5	Rural-5 Acre	Single Family Residential
18 117728 RK	R-5	Rural-5 Acre	Single Family Residential
18 118807 RK	R-9,600	Residential 9,600 sq. ft.	Single Family Residential
18 120366 MH	R-5	Rural-5 Acre	Triple Wide
18 118235 RK	R-5	Rural-5 Acre	Single Family Residential
18 101075 RK	RC	Rural Conservation	Single Family Residential
18 121182 RK	R-5	Rural-5 Acre	Single Family Residential
18 100716 RK	R-5	Rural-5 Acre	Single Family Residential
18 114471 RK	F	Forestry	Single Family Residential
17 119700 000 01 RK	R-5	Rural-5 Acre	Single Family Residential
18 120635 MH	A-10	Agriculture-10 Acre	Double Wide
18 114241 MH	R-5	Rural-5 Acre	Single Wide
18 118989 RK	RC	Rural Conservation	Single Family Residential
18 118326 RK	R-5	Rural-5 Acre	Single Family Residential
17 118512 RK	R-5	Rural-5 Acre	Single Family Residential
17 118244 RK	R-8,400	Residential 8,400 sq. ft.	Duplex
18 121102 RK	R-5	Rural-5 Acre	Accessory Apt Detached
18 120145 MH	R-5	Rural-5 Acre	Double Wide
18 115968 000 01 RK	F	Forestry	Single Family Residential
18 118820 000 01 RK	R-5	Rural-5 Acre	Single Family Residential
18 114509 RK	R-5	Rural-5 Acre	Single Family Residential
18 116693 RK	R-5	Rural-5 Acre	Single Family Residential
17 101210 000 01 RK	R-5	Rural-5 Acre	Single Family Residential
18 151896 MH	R-5	Rural-5 Acre	Double Wide
18 151719 RK	R-5	Rural-5 Acre	Single Family Residential
18 127006 RK	R-5	Rural-5 Acre	Single Family Residential
18 123710 RK	R-5	Rural-5 Acre	Single Family Residential
18 151729 RK	R-5	Rural-5 Acre	Single Family Residential
18 114753 RK	R-5	Rural-5 Acre	Single Family Residential
19 114715 RK	R-5	Rural-5 Acre	Single Family Residential
19 103383 RK	R-5	Rural-5 Acre	Single Family Residential
19 103815 MH	R-5	Rural-5 Acre	Mobile/Manufactured Home
19 105079 RK	R-5	Rural-5 Acre	Single Family Residential
18 151760 RK	R-5	Rural-5 Acre	Single Family Residential
18 151517 RK	R-5	Rural-5 Acre	Single Family Residential
18 120719 RK	R-5	Rural-5 Acre	Single Family Residential
19 103486 RK	R-5	Rural-5 Acre	Single Family Residential
19 108178 RK	R-5	Rural-5 Acre	Single Family Residential
19 103614 MH	R-5	Rural-5 Acre	Mobile/Manufactured Home
19 112423 RK	R-5	Rural-5 Acre	Single Family Residential

Accessory Dwelling Units

Index # - File Name: 1.0022 - Single Family Dwellings Data\_Snohomish County.pdf

18 122925 MH	RD	Rural Diversification	Double Wide
19 105051 RK	RD	Rural Diversification	Single Family Residential
18 151968 RK	R-5	Rural-5 Acre	Single Family Residential
18 151965 RK	R-5	Rural-5 Acre	Single Family Residential
14 102260 000 01 RK	R-5	Rural-5 Acre	Single Family Residential
19 104102 RK	R-5	Rural-5 Acre	Single Family Residential
18 151301 RK	R-5	Rural-5 Acre	Single Family Residential
18 126197 MH	RD	Rural Diversification	Double Wide
18 121487 MH	A-10 : R-5	Agriculture-10 Acre : Rural-5	Double Wide
19 114672 RK	RD	Rural Diversification	Single Family Residential
19 110988 RK	R-5	Rural-5 Acre	Single Family Residential
18 121271 RK	R-5	Rural-5 Acre	Single Family Residential
19 109455 RK	R-5	Rural-5 Acre	Single Family Residential
19 105715 RK	R-5	Rural-5 Acre	Single Family Residential
19 114430 RK	R-5	Rural-5 Acre	Single Family Residential
18 127457 RK	R-5	Rural-5 Acre	Single Family Residential
19 111355 RK	R-5	Rural-5 Acre	Single Family Residential
19 109144 RK	R-5	Rural-5 Acre	Single Family Residential
19 104510 RK	R-5	Rural-5 Acre	Single Family Residential
18 125001 RK	R-5	Rural-5 Acre	Single Family Residential
19 102772 RK	R-5	Rural-5 Acre	Single Family Residential
19 102798 RK	R-5	Rural-5 Acre	Single Family Residential
19 108400 RK	R-5	Rural-5 Acre	Accessory Apt Detached
18 101693 RK	R-5	Rural-5 Acre	Single Family Residential
19 100682 MH	R-5	Rural-5 Acre	Mobile/Manufactured Home
18 115833 RK	R-5	Rural-5 Acre	Single Family Residential
19 109607 RK	R-5	Rural-5 Acre	Single Family Residential
18 123797 MH	R-5	Rural-5 Acre	Mobile/Manufactured Home
18 122984 RK			Single Family Residential
19 109651 RK	R-5	Rural-5 Acre	SFR-Basic
18 126630 RK	R-5	Rural-5 Acre	SFR-Basic
18 126631 RK	R-5	Rural-5 Acre	SFR-Basic
18 151428 RK	R-5	Rural-5 Acre	Single Family Residential
18 127760 RK	R-5	Rural-5 Acre	Single Family Residential
18 126944 RK	R-5	Rural-5 Acre	Single Family Residential
19 106971 RK	R-5	Rural-5 Acre	Single Family Residential
19 104779 RK	R-5	Rural-5 Acre	Single Family Residential
18 123596 RK	R-5	Rural-5 Acre	Single Family Residential
19 102088 RK	R-5	Rural-5 Acre	Single Family Residential
19 107093 RK	R-5	Rural-5 Acre	Single Family Residential
19 105928 MH	R-5	Rural-5 Acre	Mobile/Manufactured Home
19 104656 RK	R-5	Rural-5 Acre	Single Family Residential
19 106060 RK	R-5	Rural-5 Acre	Single Family Residential
19 106289 RK	R-5	Rural-5 Acre	Single Family Residential
18 152199 RK	R-5	Rural-5 Acre	SFR-Basic
18 117670 MH	R-5	Rural-5 Acre	Double Wide
18 127742 RK	R-5	Rural-5 Acre	Single Family Residential

Accessory Dwelling Units

Index # - File Name: 1.0022 - Single Family Dwellings Data\_Snohomish County.pdf

19 107286 RK	R-5	Rural-5 Acre	Single Family Residential
18 152015 RK	R-9,600	Residential 9,600 sq. ft.	Duplex
19 107139 RK	R-5	Rural-5 Acre	Single Family Residential
19 111741 RK	R-7,200	Residential 7,200 sq. ft.	Duplex
19 109063 RK	R-7,200	Residential 7,200 sq. ft.	Duplex
18 126440 RK	R-7,200	Residential 7,200 sq. ft.	Duplex
18 151918 RK	R-8,400	Residential 8,400 sq. ft.	Single Family Residential
19 109453 RK	R-5	Rural-5 Acre	Single Family Residential
19 102096 RK	R-8,400	Residential 8,400 sq. ft.	Duplex
18 126817 RK	R-5	Rural-5 Acre	Single Family Residential
19 100689 RK	R-5	Rural-5 Acre	Single Family Residential
19 107260 RK	R-5	Rural-5 Acre	Single Family Residential
19 102377 RK	R-5	Rural-5 Acre	Single Family Residential
19 107762 RK	R-5	Rural-5 Acre	Single Family Residential
18 122478 RK	R-5	Rural-5 Acre	Single Family Residential
18 151682 RK	R-5	Rural-5 Acre	Accessory Apt Detached
19 110165 MH	R-5	Rural-5 Acre	Mobile/Manufactured Home
18 127703 RK	R-7,200	Residential 7,200 sq. ft.	Single Family Residential
18 125244 RK	R-5	Rural-5 Acre	Accessory Apt Detached
18 118208 RK	R-5	Rural-5 Acre	Single Family Residential
19 108918 RK	R-5	Rural-5 Acre	Single Family Residential
18 127552 RK	R-5	Rural-5 Acre	Single Family Residential
18 151507 RK	R-5	Rural-5 Acre	Single Family Residential
19 109314 RK	PRD-20,000(M	Residential 20,000 sq. ft.	Single Family Residential
19 104343 RK	PRD SA-1	Suburban Agriculture-1 Acre	Accessory Apt Detached
18 151484 RK	R-5	Rural-5 Acre	Single Family Residential
19 112226 RK	R-5	Rural-5 Acre	Accessory Apt Detached
18 127853 RK	R-5	Rural-5 Acre	Single Family Residential
19 115804 RK	R-5	Rural-5 Acre	Single Family Residential
18 151940 RK	R-5	Rural-5 Acre	Single Family Residential
19 105103 RK	R-5	Rural-5 Acre	Accessory Apt Detached
18 126367 RK	R-5	Rural-5 Acre	Single Family Residential
19 103428 RK	R-5	Rural-5 Acre	Single Family Residential
19 112316 RK	R-5	Rural-5 Acre	Single Family Residential
19 110680 RK	R-8,400	Residential 8,400 sq. ft.	Duplex
19 114587 MH	R-5	Rural-5 Acre	Mobile/Manufactured Home
19 106429 RK	R-5	Rural-5 Acre	SFR-Basic
19 104990 RK	R-8,400	Residential 8,400 sq. ft.	Single Family Residential
18 126172 MH	R-5	Rural-5 Acre	Double Wide
18 120348 RK	R-9,600	Residential 9,600 sq. ft.	Single Family Residential
19 110601 RK	RC	Rural Conservation	Single Family Residential
19 106208 RK	PRD-20,000(M	Residential 20,000 sq. ft.	Single Family Residential
18 127696 RK	PRD-20,000(M	Residential 20,000 sq. ft.	Single Family Residential
18 122870 RK	PRD-20,000(M	Residential 20,000 sq. ft.	Single Family Residential
19 110270 RK	R-5	Rural-5 Acre	Single Family Residential
18 127352 RK	PRD-20,000(M	Residential 20,000 sq. ft.	Single Family Residential
19 112918 RK	F	Forestry	Single Family Residential



Accessory Dwelling Units

Index # - File Name: 1.0022 - Single Family Dwellings Data\_Snohomish County.pdf

19 100948 RK	R-8,400	Residential 8,400 sq. ft.	Duplex
19 103981 RK	R-5	Rural-5 Acre	Single Family Residential
19 108853 RK	R-5	Rural-5 Acre	Single Family Residential
19 100893 RK	R-5	Rural-5 Acre	Single Family Residential
18 116566 RK	R-5	Rural-5 Acre	Single Family Residential
19 100963 RK	R-5	Rural-5 Acre	Single Family Residential
19 100699 RK	R-5	Rural-5 Acre	Single Family Residential
19 106587 RK	R-5	Rural-5 Acre	Single Family Residential
18 151273 RK	R-5	Rural-5 Acre	Single Family Residential
18 151793 MH	R-5	Rural-5 Acre	Double Wide
19 103357 RK	R-5	Rural-5 Acre	Single Family Residential
18 118321 RK	R-5	Rural-5 Acre	Single Family Residential
18 122633 RK	R-5	Rural-5 Acre	Single Family Residential
19 108397 RK	F	Forestry	Single Family Residential
19 106665 RK	R-5	Rural-5 Acre	Single Family Residential
19 107833 RK	R-5	Rural-5 Acre	Single Family Residential
19 107360 RK	R-5	Rural-5 Acre	Single Family Residential
19 104338 RK	R-5	Rural-5 Acre	Single Family Residential
18 127257 RK	R-5	Rural-5 Acre	Single Family Residential
19 103324 RK	A-10	Agriculture-10 Acre	Single Family Residential
19 107868 RK	R-5	Rural-5 Acre	Single Family Residential
19 109614 RK	RRT-10	Rural Resource Transition-10	Single Family Residential
18 152165 RK	R-5	Rural-5 Acre	Single Family Residential
18 126365 RK	R-5	Rural-5 Acre	Accessory Apt Detached
19 105137 RK	R-20,000	Residential 20,000 sq. ft.	Single Family Residential
19 107886 MH	MHP	Mobile Home Park	Mobile/Manufactured Home in Park
19 114171 MH	MHP	Mobile Home Park	Mobile/Manufactured Home in Park
19 104286 MH	MHP	Mobile Home Park	Mobile/Manufactured Home in Park
19 117024 MH	MHP	Mobile Home Park	Mobile/Manufactured Home in Park
19 115672 MH	MHP	Mobile Home Park	Mobile/Manufactured Home in Park
19 114401 MH	MHP	Mobile Home Park	Mobile/Manufactured Home in Park
18 152171 RK	R-5	Rural-5 Acre	Accessory Apt Detached
18 126824 RK	R-5	Rural-5 Acre	Single Family Residential
18 122884 RK	R-5	Rural-5 Acre	Accessory Apt Detached
18 151758 MH	R-5	Rural-5 Acre	Double Wide
19 104485 MH	R-5	Rural-5 Acre	Mobile/Manufactured Home
18 126359 MH	R-5	Rural-5 Acre	Double Wide
18 125089 RK	R-5	Rural-5 Acre	Single Family Residential
18 126441 RK	R-5	Rural-5 Acre	Single Family Residential
18 151728 RK	R-5	Rural-5 Acre	Single Family Residential
18 122092 RK	R-5	Rural-5 Acre	Single Family Residential
19 112158 RK	R-5	Rural-5 Acre	Single Family Residential
19 106163 MH	MHP	Mobile Home Park	Mobile/Manufactured Home in Park
19 117493 MH	MHP	Mobile Home Park	Mobile/Manufactured Home in Park
19 103888 MH	MHP	Mobile Home Park	Mobile/Manufactured Home in Park
19 109538 MH	MHP	Mobile Home Park	Mobile/Manufactured Home in Park
19 102224 MH	MHP	Mobile Home Park	MH Park-Single Wide

Accessory Dwelling Units

Index # - File Name: 1.0022 - Single Family Dwellings Data\_Snohomish County.pdf

19 102208 MH	MHP	Mobile Home Park	MH Park-Double Wide
19 103761 MH	MHP	Mobile Home Park	Mobile/Manufactured Home in Park
19 102222 MH	MHP	Mobile Home Park	MH Park-Single Wide
19 106098 MH	MHP	Mobile Home Park	Mobile/Manufactured Home in Park
19 114916 MH	R-5	Rural-5 Acre	Mobile/Manufactured Home
18 121250 RK	R-5	Rural-5 Acre	Single Family Residential
19 108489 RK	R-5	Rural-5 Acre	Single Family Residential
18 122888 RK	R-5	Rural-5 Acre	Single Family Residential
19 108116 RK	R-5	Rural-5 Acre	SFR-Basic
18 122923 RK	R-5	Rural-5 Acre	SFR-Basic
18 122390 RK	R-5	Rural-5 Acre	SFR-Basic
18 151795 RK	R-5	Rural-5 Acre	Single Family Residential
19 103748 RK	R-5	Rural-5 Acre	Single Family Residential
18 118604 RK	R-5	Rural-5 Acre	Single Family Residential
19 110236 RK	R-5	Rural-5 Acre	Single Family Residential
19 114054 RK	F	Forestry	Single Family Residential
19 113983 RK	F	Forestry	Single Family Residential
18 125635 RK	R-5	Rural-5 Acre	Single Family Residential
18 126683 RK	R-5	Rural-5 Acre	Single Family Residential
19 108107 RK	R-5	Rural-5 Acre	Single Family Residential
18 121686 RK	R-5	Rural-5 Acre	Single Family Residential
19 111945 RK	R-5	Rural-5 Acre	Single Family Residential
18 152061 RK	R-5	Rural-5 Acre	Single Family Residential
19 105168 RK	R-5	Rural-5 Acre	Single Family Residential
18 127950 RK	R-5	Rural-5 Acre	Single Family Residential
18 152276 RK	R-5	Rural-5 Acre	Single Family Residential
18 122778 RK	RRT-10	Rural Resource Transition-10	Single Family Residential
19 102020 RK	R-5	Rural-5 Acre	Single Family Residential
19 110640 RK	R-5	Rural-5 Acre	Single Family Residential
19 103104 RK	R-5	Rural-5 Acre	Single Family Residential
19 102125 RK	R-5	Rural-5 Acre	Single Family Residential
19 108487 RK	R-5	Rural-5 Acre	Single Family Residential
19 103728 RK	R-5	Rural-5 Acre	Single Family Residential
19 103868 RK	R-5	Rural-5 Acre	Single Family Residential
19 106748 MH	F and R	Forestry and Recreation	Mobile/Manufactured Home
17 111232 RK	R-7,200	Residential 7,200 sq. ft.	Duplex
18 121298 RK	R-5	Rural-5 Acre	SFR-Basic
19 111532 RK	R-5	Rural-5 Acre	SFR-Basic
18 121295 RK	R-5	Rural-5 Acre	SFR-Basic
18 121301 RK	R-5	Rural-5 Acre	SFR-Basic
18 114317 RK	R-9,600	Residential 9,600 sq. ft.	Single Family Residential
17 104196 RK	LDMR	Low Density Multiple Reside	SFR-Basic
17 104197 RK	LDMR	Low Density Multiple Reside	SFR-Basic
17 104198 RK	LDMR	Low Density Multiple Reside	SFR-Basic
17 104194 RK	LDMR	Low Density Multiple Reside	SFR-Basic
18 119162 RK	LDMR	Low Density Multiple Reside	SFR-Basic
18 119161 RK	LDMR	Low Density Multiple Reside	SFR-Basic

Accessory Dwelling Units

Index # - File Name: 1.0022 - Single Family Dwellings Data\_Snohomish County.pdf

18 119160 RK	LDMR	Low Density Multiple Reside SFR-Basic	
18 119156 RK	LDMR	Low Density Multiple Reside SFR-Basic	
18 111942 RK	LDMR	Low Density Multiple Reside SFR-Basic	
18 111923 RK	LDMR	Low Density Multiple Reside SFR-Basic	
18 151596 RK	R-5	Rural-5 Acre	Single Family Residential
19 108778 RK	R-5	Rural-5 Acre	Single Family Residential
18 126184 RK	R-5	Rural-5 Acre	Single Family Residential
18 151444 RK	R-5	Rural-5 Acre	Single Family Residential
18 151498 RK	R-5	Rural-5 Acre	Single Family Residential
19 104582 RK	R-5	Rural-5 Acre	Single Family Residential
19 117869 RK	R-5	Rural-5 Acre	Single Family Residential
19 117866 RK	R-5	Rural-5 Acre	Single Family Residential
19 117870 RK	R-5	Rural-5 Acre	Single Family Residential
19 106893 RK	R-5	Rural-5 Acre	Single Family Residential
18 112039 RK	R-5	Rural-5 Acre	Single Family Residential
18 121847 RK	R-5	Rural-5 Acre	Single Family Residential
18 122154 RK	R-5	Rural-5 Acre	Single Family Residential
19 110235 RK	LDMR	Low Density Multiple Reside SFR-Basic	
19 110248 RK	LDMR	Low Density Multiple Reside SFR-Basic	
19 110255 RK	LDMR	Low Density Multiple Reside SFR-Basic	
19 110265 RK	LDMR	Low Density Multiple Reside SFR-Basic	
19 110267 RK	LDMR	Low Density Multiple Reside SFR-Basic	
19 110584 RK	LDMR	Low Density Multiple Reside SFR-Basic	
19 110585 RK	LDMR	Low Density Multiple Reside SFR-Basic	
19 110587 RK	LDMR	Low Density Multiple Reside SFR-Basic	
19 110595 RK	LDMR	Low Density Multiple Reside SFR-Basic	
19 100791 RK	R-5	Rural-5 Acre	Single Family Residential
18 120489 RK	R-5	Rural-5 Acre	Single Family Residential
19 104929 RK	R-5	Rural-5 Acre	SFR-Basic
19 115521 RK	R-5	Rural-5 Acre	Single Family Residential
19 106600 RK	R-5	Rural-5 Acre	SFR-Basic
19 101263 RK	R-5	Rural-5 Acre	SFR-Basic
19 100715 RK	R-5	Rural-5 Acre	SFR-Basic
18 151850 RK	R-5	Rural-5 Acre	SFR-Basic
19 104648 RK	R-5	Rural-5 Acre	SFR-Basic
19 108036 RK	R-5	Rural-5 Acre	SFR-Basic
19 114529 RK	R-5	Rural-5 Acre	SFR-Basic
19 114494 RK	R-5	Rural-5 Acre	SFR-Basic
18 127888 RK	R-5	Rural-5 Acre	SFR-Basic
18 127887 RK	R-5	Rural-5 Acre	SFR-Basic
18 122066 RK	F	Forestry	Single Family Residential
18 118060 MH	F	Forestry	Double Wide
18 122388 RK	R-5	Rural-5 Acre	Single Family Residential
18 101320 RK	R-5	Rural-5 Acre	Single Family Residential
18 111784 RK	R-5	Rural-5 Acre	Single Family Residential
18 123056 RK	R-5	Rural-5 Acre	Single Family Residential
18 122351 RK	RRT-10	Rural Resource Transition-10	Single Family Residential

Accessory Dwelling Units

Index # - File Name: 1.0022 - Single Family Dwellings Data\_Snohomish County.pdf

19 105674 RK	R-5	Rural-5 Acre	Single Family Residential
19 105726 RK	R-5	Rural-5 Acre	Single Family Residential
19 102090 RK	R-5	Rural-5 Acre	Single Family Residential
19 109139 RK	R-5	Rural-5 Acre	Single Family Residential
18 151800 RK	R-5	Rural-5 Acre	Single Family Residential
18 121681 RK	R-5	Rural-5 Acre	Single Family Residential
18 120939 RK	R-5	Rural-5 Acre	Single Family Residential
19 106004 RK	R-5	Rural-5 Acre	Single Family Residential
19 105996 RK	R-5	Rural-5 Acre	Single Family Residential
18 151503 RK	R-5	Rural-5 Acre	Single Family Residential
19 113966 RK	LDMR	Low Density Multiple Reside	SFR-Basic
19 113967 RK	LDMR	Low Density Multiple Reside	SFR-Basic
19 114015 RK	LDMR	Low Density Multiple Reside	SFR-Basic
19 114017 RK	LDMR	Low Density Multiple Reside	SFR-Basic
19 115362 RK	LDMR	Low Density Multiple Reside	SFR-Basic
18 126481 RK	F	Forestry	Single Family Residential
18 152238 RK	R-5	Rural-5 Acre	SFR-Basic
19 104615 RK	R-5	Rural-5 Acre	Single Family Residential
19 100785 RK	R-5	Rural-5 Acre	Single Family Residential
19 106574 RK	R-7,200	Residential 7,200 sq. ft.	Single Family Residential
18 152107 RK	R-7,200	Residential 7,200 sq. ft.	Single Family Residential
18 151364 RK	R-7,200	Residential 7,200 sq. ft.	Duplex-Basic
19 104771 RK	R-7,200	Residential 7,200 sq. ft.	Duplex-Basic
19 104760 RK	R-7,200	Residential 7,200 sq. ft.	Duplex-Basic
19 104755 RK	R-7,200	Residential 7,200 sq. ft.	Duplex-Basic
19 104769 RK	R-7,200	Residential 7,200 sq. ft.	Duplex-Basic
19 104763 RK	R-7,200	Residential 7,200 sq. ft.	Duplex-Basic
19 104749 RK	R-7,200	Residential 7,200 sq. ft.	Duplex-Basic
18 151537 RK	R-7,200	Residential 7,200 sq. ft.	Single Family Residential
19 108984 RK	R-7,200	Residential 7,200 sq. ft.	Single Family Residential
19 109443 RK	R-7,200	Residential 7,200 sq. ft.	Single Family Residential
19 107841 RK	R-7,200	Residential 7,200 sq. ft.	SFR-Basic
19 108659 RK	R-7,200	Residential 7,200 sq. ft.	SFR-Basic
19 108663 RK	R-7,200	Residential 7,200 sq. ft.	SFR-Basic
19 107851 RK	R-7,200	Residential 7,200 sq. ft.	SFR-Basic
19 107857 RK	R-7,200	Residential 7,200 sq. ft.	SFR-Basic
19 109122 RK	R-7,200	Residential 7,200 sq. ft.	SFR-Basic
19 109128 RK	R-7,200	Residential 7,200 sq. ft.	SFR-Basic
19 109132 RK	R-7,200	Residential 7,200 sq. ft.	SFR-Basic
19 107849 RK	R-7,200	Residential 7,200 sq. ft.	SFR-Basic
19 106181 RK	R-7,200	Residential 7,200 sq. ft.	SFR-Basic
18 152281 RK	R-7,200	Residential 7,200 sq. ft.	SFR-Basic
18 152280 RK	R-7,200	Residential 7,200 sq. ft.	SFR-Basic
18 152106 RK	R-7,200	Residential 7,200 sq. ft.	Single Family Residential
18 151790 RK	R-7,200	Residential 7,200 sq. ft.	Single Family Residential
18 151791 RK	R-7,200	Residential 7,200 sq. ft.	Single Family Residential
19 108585 RK	R-7,200	Residential 7,200 sq. ft.	Single Family Residential

Accessory Dwelling Units

Index # - File Name: 1.0022 - Single Family Dwellings Data\_Snohomish County.pdf

19 104865 RK	R-5	Rural-5 Acre	Single Family Residential
19 111596 RK	CITY	City	SFR-Basic
19 111598 RK	CITY	City	SFR-Basic
19 111601 RK	CITY	City	SFR-Basic
19 111604 RK	CITY	City	SFR-Basic
19 111607 RK	CITY	City	SFR-Basic
19 111612 RK	CITY	City	SFR-Basic
19 112343 RK	CITY	City	SFR-Basic
19 110649 RK	LDMR	Low Density Multiple Reside	SFR-Basic
19 110656 RK	LDMR	Low Density Multiple Reside	SFR-Basic
19 106301 RK	LDMR	Low Density Multiple Reside	SFR-Basic
19 106302 RK	LDMR	Low Density Multiple Reside	SFR-Basic
19 106556 RK	LDMR	Low Density Multiple Reside	SFR-Basic
19 106304 RK	LDMR	Low Density Multiple Reside	SFR-Basic
19 106550 RK	LDMR	Low Density Multiple Reside	SFR-Basic
19 106308 RK	LDMR	Low Density Multiple Reside	SFR-Basic
19 106310 RK	LDMR	Low Density Multiple Reside	SFR-Basic
19 106311 RK	LDMR	Low Density Multiple Reside	SFR-Basic
19 106314 RK	LDMR	Low Density Multiple Reside	SFR-Basic
19 106315 RK	LDMR	Low Density Multiple Reside	SFR-Basic
19 106316 RK	LDMR	Low Density Multiple Reside	SFR-Basic
19 106318 RK	LDMR	Low Density Multiple Reside	SFR-Basic
19 106322 RK	LDMR	Low Density Multiple Reside	SFR-Basic
19 100786 RK	R-5	Rural-5 Acre	Single Family Residential
19 108147 RK	R-7,200	Residential 7,200 sq. ft.	SFR-Basic
19 107218 RK	R-7,200	Residential 7,200 sq. ft.	SFR-Basic
19 107224 RK	R-7,200	Residential 7,200 sq. ft.	SFR-Basic
19 107259 RK	R-7,200	Residential 7,200 sq. ft.	SFR-Basic
19 110171 RK	R-7,200	Residential 7,200 sq. ft.	SFR-Basic
19 110177 RK	R-7,200	Residential 7,200 sq. ft.	SFR-Basic
19 110178 RK	R-7,200	Residential 7,200 sq. ft.	SFR-Basic
19 110180 RK	R-7,200	Residential 7,200 sq. ft.	SFR-Basic
19 110182 RK	R-7,200	Residential 7,200 sq. ft.	SFR-Basic
19 110183 RK	R-7,200	Residential 7,200 sq. ft.	SFR-Basic
19 104123 RK	R-7,200(PRD)	Residential 7,200 sq. ft.	SFR-Basic
19 105969 RK	R-7,200(PRD)	Residential 7,200 sq. ft.	SFR-Basic
19 105979 RK	R-7,200(PRD)	Residential 7,200 sq. ft.	SFR-Basic
19 107483 RK	R-7,200(PRD)	Residential 7,200 sq. ft.	SFR-Basic
19 105959 RK	R-7,200(PRD)	Residential 7,200 sq. ft.	SFR-Basic
19 104110 RK	R-7,200(PRD)	Residential 7,200 sq. ft.	SFR-Basic
19 104124 RK	R-7,200(PRD)	Residential 7,200 sq. ft.	SFR-Basic
19 104125 RK	R-7,200(PRD)	Residential 7,200 sq. ft.	SFR-Basic
19 107488 RK	R-7,200(PRD)	Residential 7,200 sq. ft.	SFR-Basic
19 107493 RK	R-7,200(PRD)	Residential 7,200 sq. ft.	SFR-Basic
19 107420 RK	R-7,200(PRD)	Residential 7,200 sq. ft.	SFR-Basic
19 107416 RK	R-7,200(PRD)	Residential 7,200 sq. ft.	SFR-Basic
19 105981 RK	R-7,200(PRD)	Residential 7,200 sq. ft.	SFR-Basic

Accessory Dwelling Units

Index # - File Name: 1.0022 - Single Family Dwellings Data\_Snohomish County.pdf

19 107473 RK	R-7,200(PRD)	Residential 7,200 sq. ft.	SFR-Basic
19 107477 RK	R-7,200(PRD)	Residential 7,200 sq. ft.	SFR-Basic
19 107478 RK	R-7,200(PRD)	Residential 7,200 sq. ft.	SFR-Basic
19 105974 RK	R-7,200(PRD)	Residential 7,200 sq. ft.	SFR-Basic
19 104116 RK	R-7,200(PRD)	Residential 7,200 sq. ft.	SFR-Basic
19 104899 RK	R-7,200(PRD)	Residential 7,200 sq. ft.	SFR-Basic
19 105975 RK	R-7,200(PRD)	Residential 7,200 sq. ft.	SFR-Basic
18 126229 RK	R-5	Rural-5 Acre	Single Family Residential
18 151964 RK	F	Forestry	Single Family Residential
19 100697 RK	R-5	Rural-5 Acre	Single Family Residential
18 126696 RK			Single Family Residential
18 126532 RK			SFR-Basic
18 151516 MH	R-5	Rural-5 Acre	Double Wide
19 106968 RK	R-5	Rural-5 Acre	SFR-Basic
19 103893 RK	R-5	Rural-5 Acre	SFR-Basic
19 103906 RK	R-5	Rural-5 Acre	SFR-Basic
19 107709 RK	R-5	Rural-5 Acre	SFR-Basic
19 100734 RK	R-5	Rural-5 Acre	SFR-Basic
19 106965 RK	R-5	Rural-5 Acre	SFR-Basic
19 107717 RK	R-5	Rural-5 Acre	SFR-Basic
19 100833 RK	R-5	Rural-5 Acre	SFR-Basic
19 100831 RK	R-5	Rural-5 Acre	SFR-Basic
19 106984 RK	R-5	Rural-5 Acre	SFR-Basic
19 107722 RK	R-5	Rural-5 Acre	SFR-Basic
19 103881 RK	R-5	Rural-5 Acre	SFR-Basic
19 103890 RK	R-5	Rural-5 Acre	SFR-Basic
19 101024 RK	R-5	Rural-5 Acre	SFR-Basic
19 101032 RK	R-5	Rural-5 Acre	SFR-Basic
19 103882 RK	R-5	Rural-5 Acre	SFR-Basic
19 107100 RK	R-5	Rural-5 Acre	SFR-Basic
19 112228 RK	R-5	Rural-5 Acre	SFR-Basic
19 100842 RK	R-5	Rural-5 Acre	SFR-Basic
19 100844 RK	R-5	Rural-5 Acre	SFR-Basic
19 112233 RK	R-5	Rural-5 Acre	SFR-Basic
19 101527 RK	R-5	Rural-5 Acre	SFR-Basic
19 103905 RK	R-5	Rural-5 Acre	SFR-Basic
19 103885 RK	R-5	Rural-5 Acre	SFR-Basic
19 106985 RK	R-5	Rural-5 Acre	SFR-Basic
19 103883 RK	R-5	Rural-5 Acre	SFR-Basic
19 100836 RK	R-5	Rural-5 Acre	SFR-Basic
19 100847 RK	R-5	Rural-5 Acre	SFR-Basic
19 107721 RK	R-5	Rural-5 Acre	SFR-Basic
19 107713 RK	R-5	Rural-5 Acre	SFR-Basic
18 127265 RK	R-5	Rural-5 Acre	SFR-Basic
18 127272 RK	R-5	Rural-5 Acre	SFR-Basic
18 127274 RK	R-5	Rural-5 Acre	SFR-Basic
18 127277 RK	R-5	Rural-5 Acre	SFR-Basic

Accessory Dwelling Units

Index # - File Name: 1.0022 - Single Family Dwellings Data\_Snohomish County.pdf

18 127279 RK	R-5	Rural-5 Acre	SFR-Basic
18 127273 RK	R-5	Rural-5 Acre	SFR-Basic
18 127276 RK	R-5	Rural-5 Acre	SFR-Basic
18 151223 RK	R-7,200	Residential 7,200 sq. ft.	SFR-Basic
18 151224 RK	R-7,200	Residential 7,200 sq. ft.	SFR-Basic
18 151227 RK	R-7,200	Residential 7,200 sq. ft.	SFR-Basic
18 151230 RK	R-7,200	Residential 7,200 sq. ft.	SFR-Basic
19 107552 RK	LDMR : R-7,20 Low Density Multiple Reside		SFR-Basic
19 106406 RK	LDMR : R-7,20 Low Density Multiple Reside		SFR-Basic
19 106409 RK	LDMR : R-7,20 Low Density Multiple Reside		SFR-Basic
19 101389 RK	LDMR : R-7,20 Low Density Multiple Reside		SFR-Basic
19 101411 RK	LDMR : R-7,20 Low Density Multiple Reside		SFR-Basic
19 101412 RK	LDMR : R-7,20 Low Density Multiple Reside		SFR-Basic
19 101407 RK	LDMR : R-7,20 Low Density Multiple Reside		SFR-Basic
19 101380 RK	LDMR : R-7,20 Low Density Multiple Reside		SFR-Basic
19 101376 RK	LDMR : R-7,20 Low Density Multiple Reside		SFR-Basic
18 151701 RK	LDMR : R-7,20 Low Density Multiple Reside		SFR-Basic
19 102519 RK	R-5	Rural-5 Acre	Single Family Residential
18 127971 RK	R-7,200	Residential 7,200 sq. ft.	SFR-Basic
18 127972 RK	R-7,200	Residential 7,200 sq. ft.	SFR-Basic
18 127973 RK	R-7,200	Residential 7,200 sq. ft.	SFR-Basic
18 127974 RK	R-7,200	Residential 7,200 sq. ft.	SFR-Basic
18 127975 RK	R-7,200	Residential 7,200 sq. ft.	SFR-Basic
18 151264 RK	R-7,200	Residential 7,200 sq. ft.	SFR-Basic
18 127976 RK	R-7,200	Residential 7,200 sq. ft.	SFR-Basic
18 127978 RK	R-7,200	Residential 7,200 sq. ft.	SFR-Basic
18 151225 RK	R-7,200	Residential 7,200 sq. ft.	SFR-Basic
18 151265 RK	R-7,200	Residential 7,200 sq. ft.	SFR-Basic
18 151222 RK	R-7,200	Residential 7,200 sq. ft.	SFR-Basic
18 151220 RK	R-7,200	Residential 7,200 sq. ft.	SFR-Basic
18 151219 RK	R-7,200	Residential 7,200 sq. ft.	SFR-Basic
18 127980 RK	R-7,200	Residential 7,200 sq. ft.	SFR-Basic
18 127979 RK	R-7,200	Residential 7,200 sq. ft.	SFR-Basic
19 118483 RK	R-7,200	Residential 7,200 sq. ft.	SFR-Basic
19 118484 RK	R-7,200	Residential 7,200 sq. ft.	SFR-Basic
19 104313 RK	R-7,200	Residential 7,200 sq. ft.	SFR-Basic
19 104316 RK	R-7,200	Residential 7,200 sq. ft.	SFR-Basic
19 104511 RK	R-7,200	Residential 7,200 sq. ft.	SFR-Basic
19 104514 RK	R-7,200	Residential 7,200 sq. ft.	SFR-Basic
19 104516 RK	R-7,200	Residential 7,200 sq. ft.	SFR-Basic
19 102158 RK	R-7,200	Residential 7,200 sq. ft.	SFR-Basic
19 107189 RK	R-7,200	Residential 7,200 sq. ft.	SFR-Basic
19 107192 RK	R-7,200	Residential 7,200 sq. ft.	SFR-Basic
19 107200 RK	R-7,200	Residential 7,200 sq. ft.	SFR-Basic
19 104534 RK	R-7,200	Residential 7,200 sq. ft.	SFR-Basic
19 104536 RK	R-7,200	Residential 7,200 sq. ft.	SFR-Basic
19 104537 RK	R-7,200	Residential 7,200 sq. ft.	SFR-Basic

Accessory Dwelling Units

Index # - File Name: 1.0022 - Single Family Dwellings Data\_Snohomish County.pdf

19 104541 RK	R-7,200	Residential 7,200 sq. ft.	SFR-Basic
19 104543 RK	R-7,200	Residential 7,200 sq. ft.	SFR-Basic
19 107208 RK	R-7,200	Residential 7,200 sq. ft.	SFR-Basic
19 107214 RK	R-7,200	Residential 7,200 sq. ft.	SFR-Basic
19 107216 RK	R-7,200	Residential 7,200 sq. ft.	SFR-Basic
19 106733 RK	R-7,200	Residential 7,200 sq. ft.	Single Family Residential
19 106765 RK	R-7,200	Residential 7,200 sq. ft.	Single Family Residential
19 106729 RK	R-7,200	Residential 7,200 sq. ft.	Single Family Residential
19 106727 RK	R-7,200	Residential 7,200 sq. ft.	Single Family Residential
19 106767 RK	R-7,200	Residential 7,200 sq. ft.	Single Family Residential
18 124847 RK	MR	Multiple Residential	SFR-Basic
18 124849 RK	MR	Multiple Residential	SFR-Basic
18 124853 RK	MR	Multiple Residential	SFR-Basic
18 124852 RK	MR	Multiple Residential	SFR-Basic
18 124850 RK	MR	Multiple Residential	SFR-Basic
18 124851 RK	MR	Multiple Residential	SFR-Basic
18 124854 RK	MR	Multiple Residential	SFR-Basic
18 124855 RK	MR	Multiple Residential	SFR-Basic
18 152080 RK	R-7,200(PRD)	Residential 7,200 sq. ft.	SFR-Basic
18 152201 RK	R-7,200(PRD)	Residential 7,200 sq. ft.	SFR-Basic
18 152070 RK	R-7,200(PRD)	Residential 7,200 sq. ft.	SFR-Basic
18 152066 RK	R-7,200(PRD)	Residential 7,200 sq. ft.	SFR-Basic
18 152067 RK	R-7,200(PRD)	Residential 7,200 sq. ft.	SFR-Basic
18 152071 RK	R-7,200(PRD)	Residential 7,200 sq. ft.	SFR-Basic
18 152078 RK	R-7,200(PRD)	Residential 7,200 sq. ft.	SFR-Basic
18 152114 RK	R-7,200(PRD)	Residential 7,200 sq. ft.	SFR-Basic
18 152072 RK	R-7,200(PRD)	Residential 7,200 sq. ft.	SFR-Basic
18 152069 RK	R-7,200(PRD)	Residential 7,200 sq. ft.	SFR-Basic
18 152075 RK	R-7,200(PRD)	Residential 7,200 sq. ft.	SFR-Basic
18 126038 RK	LDMR : R-7,20	Low Density Multiple Reside	SFR-Basic
18 126039 RK	LDMR : R-7,20	Low Density Multiple Reside	SFR-Basic
18 126753 RK	LDMR : R-7,20	Low Density Multiple Reside	SFR-Basic
18 126754 RK	LDMR : R-7,20	Low Density Multiple Reside	SFR-Basic
18 126755 RK	LDMR : R-7,20	Low Density Multiple Reside	SFR-Basic
18 126756 RK	LDMR : R-7,20	Low Density Multiple Reside	SFR-Basic
18 126757 RK	LDMR : R-7,20	Low Density Multiple Reside	SFR-Basic
18 126759 RK	LDMR : R-7,20	Low Density Multiple Reside	SFR-Basic
18 126760 RK	LDMR : R-7,20	Low Density Multiple Reside	SFR-Basic
18 126762 RK	LDMR : R-7,20	Low Density Multiple Reside	SFR-Basic
18 126761 RK	LDMR : R-7,20	Low Density Multiple Reside	SFR-Basic
19 104225 RK	LDMR : R-7,20	Low Density Multiple Reside	SFR-Basic
19 104226 RK	LDMR : R-7,20	Low Density Multiple Reside	SFR-Basic
19 104233 RK	LDMR : R-7,20	Low Density Multiple Reside	SFR-Basic
19 104236 RK	LDMR : R-7,20	Low Density Multiple Reside	SFR-Basic
19 106400 RK	LDMR : R-7,20	Low Density Multiple Reside	SFR-Basic
19 106402 RK	LDMR : R-7,20	Low Density Multiple Reside	SFR-Basic
19 106404 RK	LDMR : R-7,20	Low Density Multiple Reside	SFR-Basic



Accessory Dwelling Units

Index # - File Name: 1.0022 - Single Family Dwellings Data\_Snohomish County.pdf

18 125783 RK	LDMR	R-7,20	Low Density Multiple Reside SFR-Basic
18 125807 RK	LDMR	R-7,20	Low Density Multiple Reside SFR-Basic
19 106323 RK	R-5	Rural-5 Acre	SFR-Basic
19 103367 RK	R-5	Rural-5 Acre	Single Family Residential
19 103403 RK	R-5	Rural-5 Acre	SFR-Basic
19 106910 RK	A-10	Agriculture-10 Acre	Single Family Residential
19 103065 RK	R-5	Rural-5 Acre	SFR-Basic
19 103053 RK	R-5	Rural-5 Acre	SFR-Basic
19 103066 RK	R-5	Rural-5 Acre	SFR-Basic
19 112378 RK	R-5	Rural-5 Acre	SFR-Basic
19 104664 RK	R-5	Rural-5 Acre	SFR-Basic
19 108785 RK	R-5	Rural-5 Acre	SFR-Basic
19 106081 RK	R-5	Rural-5 Acre	SFR-Basic
19 103210 RK	R-5	Rural-5 Acre	SFR-Basic
19 102495 RK	R-5	Rural-5 Acre	SFR-Basic
19 102499 RK	R-5	Rural-5 Acre	SFR-Basic
18 119300 MH	R-5	Rural-5 Acre	Double Wide
18 120259 RK	R-5	Rural-5 Acre	Single Family Residential
18 127356 RK	R-5	Rural-5 Acre	Single Family Residential
18 121031 RK	LDMR		Low Density Multiple Reside SFR-Basic
18 126793 RK	LDMR		Low Density Multiple Reside SFR-Basic
18 126794 RK	LDMR		Low Density Multiple Reside SFR-Basic
18 126795 RK	LDMR		Low Density Multiple Reside SFR-Basic
18 126796 RK	LDMR		Low Density Multiple Reside SFR-Basic
18 121155 RK	LDMR		Low Density Multiple Reside SFR-Basic
18 121156 RK	LDMR		Low Density Multiple Reside SFR-Basic
18 121416 RK	LDMR		Low Density Multiple Reside SFR-Basic
18 121424 RK	LDMR		Low Density Multiple Reside SFR-Basic
18 121429 RK	LDMR		Low Density Multiple Reside SFR-Basic
18 151873 RK	LDMR		Low Density Multiple Reside SFR-Basic
18 151876 RK	LDMR		Low Density Multiple Reside SFR-Basic
18 151877 RK	LDMR		Low Density Multiple Reside SFR-Basic
18 151878 RK	LDMR		Low Density Multiple Reside SFR-Basic
18 151879 RK	LDMR		Low Density Multiple Reside SFR-Basic
18 151880 RK	LDMR		Low Density Multiple Reside SFR-Basic
18 151882 RK	LDMR		Low Density Multiple Reside SFR-Basic
18 151892 RK	LDMR		Low Density Multiple Reside SFR-Basic
18 151893 RK	LDMR		Low Density Multiple Reside SFR-Basic
18 151900 RK	LDMR		Low Density Multiple Reside SFR-Basic
18 151901 RK	LDMR		Low Density Multiple Reside SFR-Basic
18 151903 RK	LDMR		Low Density Multiple Reside SFR-Basic
18 151904 RK	LDMR		Low Density Multiple Reside SFR-Basic
18 151871 RK	LDMR		Low Density Multiple Reside SFR-Basic
19 112630 RK	R-7,200	Residential 7,200 sq. ft.	Single Family Residential
19 107064 RK	R-7,200	Residential 7,200 sq. ft.	Single Family Residential
19 106983 RK	R-7,200	Residential 7,200 sq. ft.	Single Family Residential
19 106990 RK	R-7,200	Residential 7,200 sq. ft.	Single Family Residential

Accessory Dwelling Units

Index # - File Name: 1.0022 - Single Family Dwellings Data\_Snohomish County.pdf

19 107000 RK	R-7,200	Residential 7,200 sq. ft.	Single Family Residential
19 106553 RK	R-7,200	Residential 7,200 sq. ft.	Single Family Residential
18 151906 RK	LDMR	Low Density Multiple Reside	SFR-Basic
18 151315 RK	MR	Multiple Residential	SFR-Basic
18 151321 RK	MR	Multiple Residential	SFR-Basic
18 152182 RK	MR	Multiple Residential	SFR-Basic
18 152184 RK	MR	Multiple Residential	SFR-Basic
18 152185 RK	MR	Multiple Residential	SFR-Basic
18 152186 RK	MR	Multiple Residential	SFR-Basic
18 152187 RK	MR	Multiple Residential	SFR-Basic
18 152189 RK	MR	Multiple Residential	SFR-Basic
18 151400 RK	MR	Multiple Residential	SFR-Basic
18 123545 RK	R-5	Rural-5 Acre	Single Family Residential
19 105795 RK	R-5	Rural-5 Acre	SFR-Basic
18 151399 RK	MR	Multiple Residential	SFR-Basic
19 107679 RK	R-5	Rural-5 Acre	Single Family Residential
18 152180 RK	MR	Multiple Residential	SFR-Basic
18 152179 RK	MR	Multiple Residential	SFR-Basic
18 152174 RK	MR	Multiple Residential	SFR-Basic
18 152178 RK	MR	Multiple Residential	SFR-Basic
18 152152 RK	MR	Multiple Residential	SFR-Basic
18 152175 RK	MR	Multiple Residential	SFR-Basic
19 107884 RK	R-5	Rural-5 Acre	Single Family Residential
19 107869 RK	R-5	Rural-5 Acre	Single Family Residential
19 102159 RK	R-5	Rural-5 Acre	Single Family Residential
19 101540 RK	R-5	Rural-5 Acre	Single Family Residential
19 105788 RK	R-5	Rural-5 Acre	SFR-Basic
19 105790 RK	R-5	Rural-5 Acre	SFR-Basic
19 105794 RK	R-5	Rural-5 Acre	SFR-Basic
19 104927 RK	R-5	Rural-5 Acre	SFR-Basic
19 105798 RK	R-5	Rural-5 Acre	SFR-Basic
19 105789 RK	R-5	Rural-5 Acre	SFR-Basic
18 127675 RK	R-5	Rural-5 Acre	Single Family Residential
18 152098 RK	R-5	Rural-5 Acre	Single Family Residential
19 107879 RK	R-5	Rural-5 Acre	Single Family Residential
19 104914 RK	R-7,200	Residential 7,200 sq. ft.	SFR-Basic
19 104916 RK	R-7,200	Residential 7,200 sq. ft.	SFR-Basic
19 104917 RK	R-7,200	Residential 7,200 sq. ft.	SFR-Basic
19 104918 RK	R-7,200	Residential 7,200 sq. ft.	SFR-Basic
19 106007 RK	R-5	Rural-5 Acre	Single Family Residential
18 122087 RK	MR	Multiple Residential	SFR-Basic
18 122046 RK	MR	Multiple Residential	SFR-Basic
18 122048 RK	MR	Multiple Residential	SFR-Basic
18 122049 RK	MR	Multiple Residential	SFR-Basic
18 122061 RK	MR	Multiple Residential	SFR-Basic
18 122056 RK	MR	Multiple Residential	SFR-Basic
19 102098 RK	R-5	Rural-5 Acre	Single Family Residential

Accessory Dwelling Units

Index # - File Name: 1.0022 - Single Family Dwellings Data\_Snohomish County.pdf

18 123529 RK	A-10	Agriculture-10 Acre	Single Family Residential
19 111335 RK	R-5	Rural-5 Acre	Single Family Residential
19 113496 RK	R-5	Rural-5 Acre	Single Family Residential
19 114073 RK	R-5	Rural-5 Acre	Single Family Residential
17 117948 MH	R-5	Rural-5 Acre	Double Wide
18 118646 RK	R-5	Rural-5 Acre	Single Family Residential
18 127914 RK	R-12,500	Residential 12,500 sq. ft.	Single Family Residential
18 111818 RK	R-7,200	Residential 7,200 sq. ft.	Single Family Residential
19 104935 RK	R-5	Rural-5 Acre	SFR-Basic
18 127238 RK	R-5	Rural-5 Acre	SFR-Basic
19 103827 RK	R-5	Rural-5 Acre	SFR-Basic
18 120206 RK	R-5	Rural-5 Acre	Single Family Residential
19 102243 RK	R-5	Rural-5 Acre	Single Family Residential
19 101233 RK	R-5	Rural-5 Acre	Single Family Residential
18 127947 RK	R-5	Rural-5 Acre	Single Family Residential
18 127929 RK	R-5	Rural-5 Acre	Single Family Residential
18 126306 RK	R-7,200	Residential 7,200 sq. ft.	SFR-Basic
18 113459 RK	R-7,200	Residential 7,200 sq. ft.	Single Family Residential
18 125682 MH	RD	Rural Diversification	Double Wide
19 109184 MH	RD	Rural Diversification	Mobile/Manufactured Home
18 113463 RK	R-7,200	Residential 7,200 sq. ft.	Single Family Residential
19 104456 MH	R-5	Rural-5 Acre	Double Wide
18 127241 RK	R-5	Rural-5 Acre	SFR-Basic
18 127249 RK	R-5	Rural-5 Acre	SFR-Basic
19 114525 RK	R-5	Rural-5 Acre	SFR-Basic
18 127253 RK	R-5	Rural-5 Acre	SFR-Basic
19 104643 RK	R-5	Rural-5 Acre	Single Family Residential
18 127285 RK	R-7,200	Residential 7,200 sq. ft.	SFR-Basic
18 123190 RK	R-7,200	Residential 7,200 sq. ft.	SFR-Basic
18 123191 RK	R-7,200	Residential 7,200 sq. ft.	SFR-Basic
18 117966 RK	R-7,200	Residential 7,200 sq. ft.	SFR-Basic
18 117967 RK	R-7,200	Residential 7,200 sq. ft.	SFR-Basic
18 152237 RK	R-5	Rural-5 Acre	SFR-Basic
18 151633 RK	R-7,200	Residential 7,200 sq. ft.	SFR-Basic
18 151632 RK	R-7,200	Residential 7,200 sq. ft.	SFR-Basic
18 151631 RK	R-7,200	Residential 7,200 sq. ft.	SFR-Basic
18 151630 RK	R-7,200	Residential 7,200 sq. ft.	SFR-Basic
19 101897 RK	R-7,200	Residential 7,200 sq. ft.	SFR-Basic
18 124206 RK	R-5	Rural-5 Acre	Single Family Residential
19 110285 RK	R-5	Rural-5 Acre	Single Family Residential
19 110709 RK	R-5	Rural-5 Acre	Single Family Residential
19 110712 RK	R-5	Rural-5 Acre	Single Family Residential
19 111896 RK	R-5	Rural-5 Acre	Single Family Residential
19 106174 RK	R-5	Rural-5 Acre	Single Family Residential
19 102035 RK	R-5	Rural-5 Acre	Single Family Residential
19 101442 RK	R-9,600	Residential 9,600 sq. ft.	SFR-Basic
19 101450 RK	R-9,600	Residential 9,600 sq. ft.	SFR-Basic

Accessory Dwelling Units

Index # - File Name: 1.0022 - Single Family Dwellings Data\_Snohomish County.pdf

19 101447 RK	R-9,600	Residential 9,600 sq. ft.	SFR-Basic
19 101503 RK	R-9,600	Residential 9,600 sq. ft.	SFR-Basic
19 101525 RK	R-9,600	Residential 9,600 sq. ft.	SFR-Basic
19 101452 RK	R-9,600	Residential 9,600 sq. ft.	SFR-Basic
19 101504 RK	R-9,600	Residential 9,600 sq. ft.	SFR-Basic
18 151501 RK	R-5	Rural-5 Acre	Single Family Residential
19 117111 RK	R-5	Rural-5 Acre	Single Family Residential
19 114662 RK	R-5	Rural-5 Acre	Single Family Residential
19 114665 RK	R-5	Rural-5 Acre	Single Family Residential
19 114068 RK	R-5	Rural-5 Acre	Single Family Residential
19 114055 RK	R-5	Rural-5 Acre	Single Family Residential
19 113492 RK	R-5	Rural-5 Acre	Single Family Residential
19 113493 RK	R-5	Rural-5 Acre	Single Family Residential
19 110885 RK	R-5	Rural-5 Acre	Single Family Residential
19 110713 RK	R-5	Rural-5 Acre	Single Family Residential
19 111833 RK	R-5	Rural-5 Acre	Single Family Residential
19 107642 RK	R-5	Rural-5 Acre	Single Family Residential
19 108713 RK	R-5	Rural-5 Acre	Single Family Residential
19 108948 RK	R-5	Rural-5 Acre	Single Family Residential
19 107148 RK	R-5	Rural-5 Acre	Single Family Residential
19 106447 RK	R-5	Rural-5 Acre	Single Family Residential
19 106173 RK	R-5	Rural-5 Acre	Single Family Residential
19 106110 RK	R-5	Rural-5 Acre	Single Family Residential
19 103712 RK	R-5	Rural-5 Acre	Single Family Residential
19 102299 RK	R-5	Rural-5 Acre	Single Family Residential
19 106486 RK	R-5	Rural-5 Acre	Single Family Residential
19 108161 RK	R-5	Rural-5 Acre	Single Family Residential
19 106405 RK	R-5	Rural-5 Acre	Single Family Residential
19 107610 RK	R-5	Rural-5 Acre	Single Family Residential
19 108459 RK	R-5	Rural-5 Acre	Single Family Residential
19 110717 RK	R-5	Rural-5 Acre	Single Family Residential
19 104489 RK	R-5	Rural-5 Acre	Single Family Residential
19 106122 RK	R-5	Rural-5 Acre	Single Family Residential
19 103909 RK	R-5	Rural-5 Acre	Single Family Residential
19 109431 RK	LDMR	Low Density Multiple Reside	SFR-Basic
19 109434 RK	LDMR	Low Density Multiple Reside	SFR-Basic
19 109436 RK	LDMR	Low Density Multiple Reside	SFR-Basic
19 109437 RK	LDMR	Low Density Multiple Reside	SFR-Basic
19 113674 RK	LDMR	Low Density Multiple Reside	SFR-Basic
19 114486 RK	LDMR	Low Density Multiple Reside	SFR-Basic
19 117524 RK	LDMR	Low Density Multiple Reside	SFR-Basic
19 117526 RK	LDMR	Low Density Multiple Reside	SFR-Basic
19 115370 RK	LDMR	Low Density Multiple Reside	SFR-Basic
19 115367 RK	LDMR	Low Density Multiple Reside	SFR-Basic
19 115366 RK	LDMR	Low Density Multiple Reside	SFR-Basic
19 114490 RK	LDMR	Low Density Multiple Reside	SFR-Basic
19 114649 RK	LDMR	Low Density Multiple Reside	SFR-Basic

Accessory Dwelling Units

Index # - File Name: 1.0022 - Single Family Dwellings Data\_Snohomish County.pdf

19 113628 RK	LDMR	Low Density Multiple Reside	SFR-Basic
19 109438 RK	LDMR	Low Density Multiple Reside	SFR-Basic
19 113642 RK	LDMR	Low Density Multiple Reside	SFR-Basic
19 109440 RK	LDMR	Low Density Multiple Reside	SFR-Basic
19 109441 RK	LDMR	Low Density Multiple Reside	SFR-Basic
19 110934 RK	R-7,200(PRD)	Residential 7,200 sq. ft.	SFR-Basic
19 101383 RK	R-7,200(PRD)	Residential 7,200 sq. ft.	SFR-Basic
19 110935 RK	R-7,200(PRD)	Residential 7,200 sq. ft.	SFR-Basic
19 102036 RK	R-7,200(PRD)	Residential 7,200 sq. ft.	SFR-Basic
19 103690 RK	R-7,200(PRD)	Residential 7,200 sq. ft.	SFR-Basic
19 103697 RK	R-7,200(PRD)	Residential 7,200 sq. ft.	SFR-Basic
19 103699 RK	R-7,200(PRD)	Residential 7,200 sq. ft.	SFR-Basic
19 107982 RK	R-7,200(PRD)	Residential 7,200 sq. ft.	SFR-Basic
19 108229 RK	R-7,200(PRD)	Residential 7,200 sq. ft.	SFR-Basic
19 109397 RK	R-7,200(PRD)	Residential 7,200 sq. ft.	SFR-Basic
19 109402 RK	R-7,200(PRD)	Residential 7,200 sq. ft.	SFR-Basic
19 110566 RK	R-7,200(PRD)	Residential 7,200 sq. ft.	SFR-Basic
19 110569 RK	R-7,200(PRD)	Residential 7,200 sq. ft.	SFR-Basic
19 110915 RK	R-7,200(PRD)	Residential 7,200 sq. ft.	SFR-Basic
19 110910 RK	R-7,200(PRD)	Residential 7,200 sq. ft.	SFR-Basic
19 110913 RK	R-7,200(PRD)	Residential 7,200 sq. ft.	SFR-Basic
19 110917 RK	R-7,200(PRD)	Residential 7,200 sq. ft.	SFR-Basic
19 101144 RK	R-5	Rural-5 Acre	Single Family Residential
18 151493 RK	R-5	Rural-5 Acre	Accessory Apt Detached
19 102432 RK	R-5	Rural-5 Acre	SFR-Basic
19 102331 RK	R-5	Rural-5 Acre	SFR-Basic
19 102101 RK	R-7,200	Residential 7,200 sq. ft.	SFR-Basic
19 102105 RK	R-7,200	Residential 7,200 sq. ft.	SFR-Basic
19 103071 RK	R-7,200	Residential 7,200 sq. ft.	SFR-Basic
19 102106 RK	R-7,200	Residential 7,200 sq. ft.	SFR-Basic
19 103086 RK	R-7,200	Residential 7,200 sq. ft.	SFR-Basic
19 102067 RK	R-7,200	Residential 7,200 sq. ft.	SFR-Basic
19 102061 RK	R-7,200	Residential 7,200 sq. ft.	SFR-Basic
19 102066 RK	R-7,200	Residential 7,200 sq. ft.	SFR-Basic
19 103109 RK	R-7,200	Residential 7,200 sq. ft.	SFR-Basic
18 151540 RK	R-7,200	Residential 7,200 sq. ft.	Single Family Residential
19 109041 RK	R-7,200	Residential 7,200 sq. ft.	Single Family Residential
19 109445 RK	R-7,200	Residential 7,200 sq. ft.	Single Family Residential
19 110305 RK	R-7,200	Residential 7,200 sq. ft.	Single Family Residential
19 111266 RK	R-5	Rural-5 Acre	Single Family Residential
18 151740 RK	LDMR	Low Density Multiple Reside	Single Family Residential
18 151741 RK	LDMR	Low Density Multiple Reside	Single Family Residential
19 105866 RK	R-5	Rural-5 Acre	Single Family Residential
19 110298 RK	R-7,200	Residential 7,200 sq. ft.	Single Family Residential
19 113289 RK	R-7,200(PRD)	Residential 7,200 sq. ft.	SFR-Basic
19 114378 RK	R-7,200(PRD)	Residential 7,200 sq. ft.	SFR-Basic
19 114373 RK	R-7,200(PRD)	Residential 7,200 sq. ft.	SFR-Basic

Accessory Dwelling Units

Index # - File Name: 1.0022 - Single Family Dwellings Data\_Snohomish County.pdf

19 115096 RK	R-7,200(PRD)	Residential 7,200 sq. ft.	SFR-Basic
19 106126 RK	BP	Business Park	SFR-Basic
19 105000 RK	BP	Business Park	SFR-Basic
19 105002 RK	BP	Business Park	SFR-Basic
19 106137 RK	BP	Business Park	SFR-Basic
19 109413 RK	BP	Business Park	SFR-Basic
19 109417 RK	BP	Business Park	SFR-Basic
19 109418 RK	BP	Business Park	SFR-Basic
19 109430 RK	BP	Business Park	SFR-Basic
19 109419 RK	BP	Business Park	SFR-Basic
19 109421 RK	BP	Business Park	SFR-Basic
19 109428 RK	BP	Business Park	SFR-Basic
19 109423 RK	BP	Business Park	SFR-Basic
19 109424 RK	BP	Business Park	SFR-Basic
19 111672 RK	BP	Business Park	SFR-Basic
19 111676 RK	BP	Business Park	SFR-Basic
19 111677 RK	BP	Business Park	SFR-Basic
19 111680 RK	BP	Business Park	SFR-Basic
19 111684 RK	BP	Business Park	SFR-Basic
19 111689 RK	BP	Business Park	SFR-Basic
19 111691 RK	BP	Business Park	SFR-Basic
19 105017 RK	BP	Business Park	SFR-Basic
19 105016 RK	BP	Business Park	SFR-Basic
19 105005 RK	BP	Business Park	SFR-Basic
19 109426 RK	BP	Business Park	SFR-Basic
19 109444 RK	BP	Business Park	SFR-Basic
19 109427 RK	BP	Business Park	SFR-Basic
19 103107 RK	R-5	Rural-5 Acre	Single Family Residential
19 103172 RK	SA-1	Suburban Agriculture-1 Acre	Single Family Residential
19 103174 RK	SA-1	Suburban Agriculture-1 Acre	Single Family Residential
19 115097 RK	R-7,200(PRD)	Residential 7,200 sq. ft.	SFR-Basic
19 113292 RK	R-7,200(PRD)	Residential 7,200 sq. ft.	SFR-Basic
19 115094 RK	R-7,200(PRD)	Residential 7,200 sq. ft.	Single Family Residential
19 115577 RK	R-7,200(PRD)	Residential 7,200 sq. ft.	SFR-Basic
19 101048 RK	R-5	Rural-5 Acre	Single Family Residential
18 151745 MH	R-5	Rural-5 Acre	Double Wide
19 115016 RK	R-7,200	Residential 7,200 sq. ft.	Single Family Residential
19 108966 RK	R-7,200(PRD)	Residential 7,200 sq. ft.	SFR-Basic
19 109014 RK	R-7,200(PRD)	Residential 7,200 sq. ft.	SFR-Basic
19 109005 RK	R-7,200(PRD)	Residential 7,200 sq. ft.	SFR-Basic
19 109011 RK	R-7,200(PRD)	Residential 7,200 sq. ft.	SFR-Basic
19 109026 RK	R-7,200(PRD)	Residential 7,200 sq. ft.	SFR-Basic
19 109028 RK	R-7,200(PRD)	Residential 7,200 sq. ft.	SFR-Basic
19 117521 RK	R-7,200(PRD)	Residential 7,200 sq. ft.	SFR-Basic
19 117522 RK	R-7,200(PRD)	Residential 7,200 sq. ft.	SFR-Basic
19 115315 RK	R-7,200(PRD)	Residential 7,200 sq. ft.	SFR-Basic
19 109029 RK	R-7,200(PRD)	Residential 7,200 sq. ft.	SFR-Basic

Accessory Dwelling Units

Index # - File Name: 1.0022 - Single Family Dwellings Data\_Snohomish County.pdf

19 115319 RK	R-7,200(PRD)	Residential 7,200 sq. ft.	SFR-Basic
19 109025 RK	R-7,200(PRD)	Residential 7,200 sq. ft.	SFR-Basic
19 109021 RK	R-7,200(PRD)	Residential 7,200 sq. ft.	SFR-Basic
19 111143 RK	R-7,200(PRD)	Residential 7,200 sq. ft.	SFR-Basic
19 115308 RK	R-7,200(PRD)	Residential 7,200 sq. ft.	SFR-Basic
19 115312 RK	R-7,200(PRD)	Residential 7,200 sq. ft.	SFR-Basic
19 117517 RK	R-7,200(PRD)	Residential 7,200 sq. ft.	SFR-Basic
19 117519 RK	R-7,200(PRD)	Residential 7,200 sq. ft.	SFR-Basic
19 117520 RK	R-7,200(PRD)	Residential 7,200 sq. ft.	SFR-Basic
19 115309 RK	R-7,200(PRD)	Residential 7,200 sq. ft.	SFR-Basic
19 114412 RK	R-7,200(PRD)	Residential 7,200 sq. ft.	SFR-Basic
19 103386 RK	R-5	Rural-5 Acre	SFR-Basic
19 103393 RK	R-5	Rural-5 Acre	SFR-Basic
19 103390 RK	R-5	Rural-5 Acre	SFR-Basic
19 103395 RK	R-5	Rural-5 Acre	SFR-Basic
19 103384 RK	R-5	Rural-5 Acre	SFR-Basic
19 103300 RK	R-5	Rural-5 Acre	SFR-Basic
19 103308 RK	R-5	Rural-5 Acre	SFR-Basic
19 104933 RK	R-5	Rural-5 Acre	SFR-Basic
19 115844 RK	R-5	Rural-5 Acre	SFR-Basic
19 108217 RK	R-9,600	Residential 9,600 sq. ft.	Single Family Residential
19 105194 RK	LDMR	Low Density Multiple Reside	SFR-Basic
19 105724 RK	LDMR	Low Density Multiple Reside	SFR-Basic
19 105196 RK	LDMR	Low Density Multiple Reside	SFR-Basic
19 105728 RK	LDMR	Low Density Multiple Reside	SFR-Basic
19 105730 RK	LDMR	Low Density Multiple Reside	SFR-Basic
19 105732 RK	LDMR	Low Density Multiple Reside	SFR-Basic
19 105733 RK	LDMR	Low Density Multiple Reside	SFR-Basic
19 110689 RK	LDMR	Low Density Multiple Reside	SFR-Basic
19 110691 RK	LDMR	Low Density Multiple Reside	SFR-Basic
19 110693 RK	LDMR	Low Density Multiple Reside	SFR-Basic
19 110694 RK	LDMR	Low Density Multiple Reside	SFR-Basic
19 110695 RK	LDMR	Low Density Multiple Reside	SFR-Basic
19 110701 RK	LDMR	Low Density Multiple Reside	SFR-Basic
19 110706 RK	LDMR	Low Density Multiple Reside	SFR-Basic
19 110711 RK	LDMR	Low Density Multiple Reside	SFR-Basic
19 110718 RK	LDMR	Low Density Multiple Reside	SFR-Basic
19 110721 RK	LDMR	Low Density Multiple Reside	SFR-Basic
19 114520 RK	LDMR	Low Density Multiple Reside	SFR-Basic
19 114349 RK	LDMR	Low Density Multiple Reside	SFR-Basic
19 114359 RK	LDMR	Low Density Multiple Reside	SFR-Basic
19 110722 RK	LDMR	Low Density Multiple Reside	SFR-Basic
19 104908 RK	R-5	Rural-5 Acre	Single Family Residential
19 107623 RK	MR	Multiple Residential	SFR-Basic
19 107621 RK	MR	Multiple Residential	SFR-Basic
19 107619 RK	MR	Multiple Residential	SFR-Basic
19 107605 RK	MR	Multiple Residential	SFR-Basic

Accessory Dwelling Units

Index # - File Name: 1.0022 - Single Family Dwellings Data\_Snohomish County.pdf

19 107625 RK	MR	Multiple Residential	SFR-Basic
19 107628 RK	MR	Multiple Residential	SFR-Basic
19 113593 RK	MR	Multiple Residential	SFR-Basic
19 113621 RK	MR	Multiple Residential	SFR-Basic
19 113626 RK	MR	Multiple Residential	SFR-Basic
19 114408 RK	MR	Multiple Residential	SFR-Basic
19 114411 RK	MR	Multiple Residential	SFR-Basic
19 115286 RK	MR	Multiple Residential	SFR-Basic
19 115330 RK	MR	Multiple Residential	SFR-Basic
19 117442 RK	MR	Multiple Residential	SFR-Basic
19 117443 RK	MR	Multiple Residential	SFR-Basic
19 107212 MH	R-5	Rural-5 Acre	Mobile/Manufactured Home
19 102199 RK	R-5	Rural-5 Acre	Single Family Residential
19 110726 RK	LDMR	Low Density Multiple Reside	SFR-Basic
19 110729 RK	LDMR	Low Density Multiple Reside	SFR-Basic
19 110742 RK	LDMR	Low Density Multiple Reside	SFR-Basic
19 110733 RK	LDMR	Low Density Multiple Reside	SFR-Basic
19 103824 RK	R-5	Rural-5 Acre	Single Family Residential
19 104190 MH	R-5	Rural-5 Acre	Double Wide
19 113589 RK	MR	Multiple Residential	SFR-Basic
19 114404 RK	MR	Multiple Residential	SFR-Basic
19 115321 RK	MR	Multiple Residential	SFR-Basic
19 105071 RK	R-5	RURAL-5 ACRE	SFR-Basic
19 105089 RK	R-5	Rural-5 Acre	SFR-Basic
19 105083 RK	R-5	Rural-5 Acre	SFR-Basic
19 105087 RK	R-5	Rural-5 Acre	SFR-Basic
19 105073 RK	R-5	Rural-5 Acre	SFR-Basic
19 105090 RK	R-5	Rural-5 Acre	SFR-Basic
19 105086 RK	R-5	Rural-5 Acre	SFR-Basic
19 105074 RK	R-5	Rural-5 Acre	SFR-Basic
19 105084 RK	R-5	Rural-5 Acre	SFR-Basic
19 104870 RK	R-5	Rural-5 Acre	SFR-Basic
19 105080 RK	R-5	Rural-5 Acre	SFR-Basic
19 104871 RK	R-5	Rural-5 Acre	SFR-Basic
19 106326 RK	R-5	Rural-5 Acre	Single Family Residential
19 106331 RK	R-5	Rural-5 Acre	Single Family Residential
19 106031 RK	R-5	Rural-5 Acre	Single Family Residential
19 106814 RK	R-5	Rural-5 Acre	Single Family Residential
19 107678 RK	R-5	Rural-5 Acre	Single Family Residential
19 111707 RK	CITY	City	SFR-Basic
19 111711 RK	CITY	City	SFR-Basic
19 115243 RK	CITY	City	SFR-Basic
19 111728 RK	CITY	City	SFR-Basic
19 111700 RK	CITY	City	SFR-Basic
19 111699 RK	CITY	City	SFR-Basic
19 111695 RK	CITY	City	SFR-Basic
19 111693 RK	CITY	City	SFR-Basic



Accessory Dwelling Units

Index # - File Name: 1.0022 - Single Family Dwellings Data\_Snohomish County.pdf

19 117444 RK	MR	Multiple Residential	SFR-Basic
19 115282 RK	MR	Multiple Residential	SFR-Basic
19 114414 RK	MR	Multiple Residential	SFR-Basic
19 107554 RK	MR	Multiple Residential	SFR-Basic
19 107624 RK	MR	Multiple Residential	SFR-Basic
19 107618 RK	MR	Multiple Residential	SFR-Basic
19 114995 RK	R-5	Rural-5 Acre	SFR-Basic
19 114988 RK	R-5	Rural-5 Acre	SFR-Basic
19 116922 RK	R-5	Rural-5 Acre	Single Family Residential
19 114713 RK	R-5	Rural-5 Acre	Single Family Residential
19 108671 RK	R-5	Rural-5 Acre	Single Family Residential
19 108890 RK	R-5	Rural-5 Acre	Single Family Residential
19 115301 RK	R-7,200	Residential 7,200 sq. ft.	SFR-Basic
19 115298 RK	R-7,200	Residential 7,200 sq. ft.	SFR-Basic
19 114487 RK	R-7,200	Residential 7,200 sq. ft.	SFR-Basic
19 114441 RK	R-7,200	Residential 7,200 sq. ft.	SFR-Basic
19 114406 RK	R-7,200	Residential 7,200 sq. ft.	SFR-Basic
19 111501 RK	R-7,200	Residential 7,200 sq. ft.	SFR-Basic
19 111497 RK	R-7,200	Residential 7,200 sq. ft.	SFR-Basic
19 111496 RK	R-7,200	Residential 7,200 sq. ft.	SFR-Basic
19 111481 RK	R-7,200	Residential 7,200 sq. ft.	SFR-Basic
19 111476 RK	R-7,200	Residential 7,200 sq. ft.	SFR-Basic
19 111463 RK	R-7,200	Residential 7,200 sq. ft.	SFR-Basic
19 111459 RK	R-7,200	Residential 7,200 sq. ft.	SFR-Basic
19 111458 RK	R-7,200	Residential 7,200 sq. ft.	SFR-Basic
19 111451 RK	R-7,200	Residential 7,200 sq. ft.	SFR-Basic
19 108586 RK	R-7,200	Residential 7,200 sq. ft.	SFR-Basic
19 108613 RK	R-7,200	Residential 7,200 sq. ft.	SFR-Basic
19 108559 RK	R-7,200	Residential 7,200 sq. ft.	SFR-Basic
19 108537 RK	R-7,200	Residential 7,200 sq. ft.	SFR-Basic
19 108608 RK	R-7,200	Residential 7,200 sq. ft.	SFR-Basic
19 111465 RK	R-7,200	Residential 7,200 sq. ft.	SFR-Basic
19 114437 RK	R-7,200	Residential 7,200 sq. ft.	SFR-Basic
19 115307 RK	R-7,200	Residential 7,200 sq. ft.	SFR-Basic
19 115303 RK	R-7,200	Residential 7,200 sq. ft.	SFR-Basic
19 114478 RK	R-7,200	Residential 7,200 sq. ft.	SFR-Basic
19 111484 RK	R-7,200	Residential 7,200 sq. ft.	SFR-Basic
19 114483 RK	R-7,200	Residential 7,200 sq. ft.	SFR-Basic
19 115302 RK	R-7,200	Residential 7,200 sq. ft.	SFR-Basic
19 117498 RK	R-7,200	Residential 7,200 sq. ft.	SFR-Basic
19 111943 RK	R-5	Rural-5 Acre	SFR-Basic
19 117499 RK	R-7,200	Residential 7,200 sq. ft.	SFR-Basic
19 115294 RK	R-7,200	Residential 7,200 sq. ft.	SFR-Basic
19 111498 RK	R-7,200	Residential 7,200 sq. ft.	SFR-Basic
19 108580 RK	R-7,200	Residential 7,200 sq. ft.	SFR-Basic
19 111470 RK	R-7,200	Residential 7,200 sq. ft.	SFR-Basic
19 108584 RK	R-7,200	Residential 7,200 sq. ft.	SFR-Basic

Accessory Dwelling Units

Index # - File Name: 1.0022 - Single Family Dwellings Data\_Snohomish County.pdf

19 108576 RK	R-7,200	Residential 7,200 sq. ft.	SFR-Basic
19 108597 RK	R-7,200	Residential 7,200 sq. ft.	SFR-Basic
19 111455 RK	R-7,200	Residential 7,200 sq. ft.	SFR-Basic
19 111471 RK	R-7,200	Residential 7,200 sq. ft.	SFR-Basic
19 114428 RK	R-7,200	Residential 7,200 sq. ft.	SFR-Basic
19 115295 RK	R-7,200	Residential 7,200 sq. ft.	SFR-Basic
19 117497 RK	R-7,200	Residential 7,200 sq. ft.	SFR-Basic
19 114680 RK	R-5	Rural-5 Acre	Single Family Residential
19 114686 RK	R-5	Rural-5 Acre	Single Family Residential
19 115517 RK	R-5	Rural-5 Acre	Single Family Residential
19 117494 RK	R-7,200	Residential 7,200 sq. ft.	SFR-Basic
19 117495 RK	R-7,200	Residential 7,200 sq. ft.	SFR-Basic
19 117496 RK	R-7,200	Residential 7,200 sq. ft.	SFR-Basic
19 117500 RK	R-7,200	Residential 7,200 sq. ft.	SFR-Basic
19 118643 RK	R-7,200	Residential 7,200 sq. ft.	SFR-Basic
19 108460 RK	A-10	Agriculture-10 Acre	Single Family Residential
19 112668 RK	LDMR	Low Density Multiple Reside	SFR-Basic
19 112672 RK	LDMR	Low Density Multiple Reside	SFR-Basic
19 112674 RK	LDMR	Low Density Multiple Reside	SFR-Basic
19 109618 RK	R-5	Rural-5 Acre	Duplex
19 106797 RK	R-5	Rural-5 Acre	Accessory Apt Detached
19 111821 RK	LDMR	Low Density Multiple Reside	SFR-Basic
19 111830 RK	LDMR	Low Density Multiple Reside	SFR-Basic
19 112280 RK	LDMR	Low Density Multiple Reside	SFR-Basic
19 112294 RK	LDMR	Low Density Multiple Reside	SFR-Basic
19 112289 RK	LDMR	Low Density Multiple Reside	SFR-Basic
19 112297 RK	LDMR	Low Density Multiple Reside	SFR-Basic
19 112286 RK	LDMR	Low Density Multiple Reside	SFR-Basic
19 111832 RK	LDMR	Low Density Multiple Reside	SFR-Basic
19 111772 RK	CITY	City	SFR-Basic
19 111770 RK	CITY	City	SFR-Basic
19 111764 RK	CITY	City	SFR-Basic
19 111762 RK	CITY	City	SFR-Basic
19 111759 RK	CITY	City	SFR-Basic
19 111757 RK	CITY	City	SFR-Basic
19 111754 RK	CITY	City	SFR-Basic
19 111751 RK	CITY	City	SFR-Basic
19 111749 RK	CITY	City	SFR-Basic
19 114552 RK	LDMR	Low Density Multiple Reside	Single Family Residential
19 113533 RK	LDMR	Low Density Multiple Reside	Single Family Residential
19 114556 RK	LDMR	Low Density Multiple Reside	Single Family Residential
19 107207 RK	R-7,200	Residential 7,200 sq. ft.	Single Family Residential
19 103120 RK	R-7,200	Residential 7,200 sq. ft.	Duplex
19 117529 RK	R-7,200	Residential 7,200 sq. ft.	SFR-Basic
19 117528 RK	R-7,200	Residential 7,200 sq. ft.	SFR-Basic
19 115411 RK	R-7,200	Residential 7,200 sq. ft.	SFR-Basic
19 115412 RK	R-7,200	Residential 7,200 sq. ft.	SFR-Basic

Accessory Dwelling Units

Index # - File Name: 1.0022 - Single Family Dwellings Data\_Snohomish County.pdf

19 114449 RK	R-7,200	Residential 7,200 sq. ft.	SFR-Basic
19 117527 RK	R-7,200	Residential 7,200 sq. ft.	SFR-Basic
19 114456 RK	R-7,200	Residential 7,200 sq. ft.	SFR-Basic
19 115410 RK	R-7,200	Residential 7,200 sq. ft.	SFR-Basic
19 114464 RK	R-7,200	Residential 7,200 sq. ft.	SFR-Basic
19 114466 RK	R-7,200	Residential 7,200 sq. ft.	SFR-Basic
19 114474 RK	R-7,200	Residential 7,200 sq. ft.	SFR-Basic
19 114433 RK	R-7,200	Residential 7,200 sq. ft.	SFR-Basic
19 112700 RK	LDMR	Low Density Multiple Reside Single Family Residential	
19 114624 RK	LDMR	Low Density Multiple Reside Single Family Residential	
19 114558 RK	LDMR	Low Density Multiple Reside Single Family Residential	
19 114562 RK	LDMR	Low Density Multiple Reside Single Family Residential	
19 114082 RK	R-7,200	Residential 7,200 sq. ft.	SFR-Basic
19 114088 RK	R-7,200	Residential 7,200 sq. ft.	SFR-Basic
19 114097 RK	R-7,200	Residential 7,200 sq. ft.	SFR-Basic
19 114102 RK	R-7,200	Residential 7,200 sq. ft.	SFR-Basic
19 113340 RK	R-7,200(PRD)	Residential 7,200 sq. ft.	SFR-Basic
19 117459 RK	R-7,200(PRD)	Residential 7,200 sq. ft.	SFR-Basic
19 117462 RK	R-7,200(PRD)	Residential 7,200 sq. ft.	SFR-Basic
19 117463 RK	R-7,200(PRD)	Residential 7,200 sq. ft.	SFR-Basic
19 117458 RK	R-7,200(PRD)	Residential 7,200 sq. ft.	SFR-Basic
19 113348 RK	R-7,200(PRD)	Residential 7,200 sq. ft.	SFR-Basic
19 113346 RK	R-7,200(PRD)	Residential 7,200 sq. ft.	SFR-Basic
19 113329 RK	R-7,200(PRD)	Residential 7,200 sq. ft.	SFR-Basic
19 115364 RK	LDMR	Low Density Multiple Reside SFR-Basic	
19 117478 RK	LDMR	Low Density Multiple Reside SFR-Basic	
19 117479 RK	LDMR	Low Density Multiple Reside SFR-Basic	
19 117480 RK	LDMR	Low Density Multiple Reside SFR-Basic	
19 114208 RK	R-5	Rural-5 Acre	SFR-Basic
19 114210 RK	R-5	Rural-5 Acre	SFR-Basic
19 114218 RK	R-5	Rural-5 Acre	SFR-Basic
19 114692 RK	R-5	Rural-5 Acre	Single Family Residential
19 114217 RK	R-5	Rural-5 Acre	SFR-Basic
19 114211 RK	R-5	Rural-5 Acre	SFR-Basic
19 115359 RK	R-7,200	Residential 7,200 sq. ft.	Duplex-Basic
19 117471 RK	R-7,200	Residential 7,200 sq. ft.	Duplex-Basic
19 113584 RK	R-7,200	Residential 7,200 sq. ft.	SFR-Basic
19 115357 RK	R-7,200	Residential 7,200 sq. ft.	Duplex-Basic
19 114409 MH	R-5	Rural-5 Acre	Mobile/Manufactured Home
19 117382 RK	R-7,200(PRD)	Residential 7,200 sq. ft.	SFR-Basic
19 114192 RK	R-9,600(PRD)	Residential 9,600 sq. ft.	SFR-Basic
19 114194 RK	R-9,600(PRD)	Residential 9,600 sq. ft.	SFR-Basic
19 114189 RK	R-9,600(PRD)	Residential 9,600 sq. ft.	SFR-Basic
19 114190 RK	R-9,600(PRD)	Residential 9,600 sq. ft.	SFR-Basic
19 115259 RK	R-7,200(PRD)	Residential 7,200 sq. ft.	SFR-Basic
19 115263 RK	R-7,200(PRD)	Residential 7,200 sq. ft.	SFR-Basic
19 114965 RK	R-7200(PRD)_	Residential 7,200 sq. ft.	SFR-Basic

Accessory Dwelling Units

Index # - File Name: 1.0022 - Single Family Dwellings Data\_Snohomish County.pdf

19 114963 RK	R-7200(PRD)_	Residential 7,200 sq. ft.	SFR-Basic
19 114964 RK	R-7200(PRD)_	Residential 7,200 sq. ft.	SFR-Basic
19 114970 RK	R-7200(PRD)_	Residential 7,200 sq. ft.	SFR-Basic
19 114174 RK	A-10	Agriculture-10 Acre	Single Family Residential
19 114232 RK	R-9,600(PRD)	Residential 9,600 sq. ft.	SFR-Basic
19 114955 RK	R-7200(PRD)_	Residential 7,200 sq. ft.	SFR-Basic
19 114960 RK	R-7200(PRD)_	Residential 7,200 sq. ft.	SFR-Basic
19 115363 RK	LDMR	Low Density Multiple Reside	SFR-Basic
19 114927 RK	R-7,200	Residential 7,200 sq. ft.	SFR-Basic
19 114941 RK	R-7200(PRD)_	Residential 7,200 sq. ft.	SFR-Basic
18 126463 RK	R-7,200	Residential 7,200 sq. ft.	Single Family Residential
19 114954 RK	R-7200(PRD)_	Residential 7,200 sq. ft.	SFR-Basic
19 116996 RK	R-5	Rural-5 Acre	SFR-Basic
20 107478 RK	R-7200(PRD)_	Residential 7,200 sq. ft.	SFR-Basic
20 108280 RK	R-7200(PRD)_	Residential 7,200 sq. ft.	SFR-Basic
20 108282 RK	R-7200(PRD)_	Residential 7,200 sq. ft.	SFR-Basic
20 107482 RK	R-7200(PRD)_	Residential 7,200 sq. ft.	SFR-Basic
20 107481 RK	R-7200(PRD)_	Residential 7,200 sq. ft.	SFR-Basic
20 107479 RK	R-7200(PRD)_	Residential 7,200 sq. ft.	SFR-Basic
19 116494 RK	R-9,600(PRD)	Residential 9,600 sq. ft.	SFR-Basic
19 116496 RK	R-9,600(PRD)	Residential 9,600 sq. ft.	SFR-Basic
20 100083 RK	R-9,600(PRD)	Residential 9,600 sq. ft.	SFR-Basic
20 100093 RK	R-9,600(PRD)	Residential 9,600 sq. ft.	SFR-Basic
20 100091 RK	R-9,600(PRD)	Residential 9,600 sq. ft.	SFR-Basic
19 117710 RK	R-9,600(PRD)	Residential 9,600 sq. ft.	SFR-Basic
19 117702 RK	R-9,600(PRD)	Residential 9,600 sq. ft.	SFR-Basic
19 117642 RK	R-5	Rural-5 Acre	SFR-Basic
19 117643 RK	R-5	Rural-5 Acre	SFR-Basic
19 117644 RK	R-5	Rural-5 Acre	SFR-Basic
19 117645 RK	R-5	Rural-5 Acre	SFR-Basic
19 117565 RK	R-5	Rural-5 Acre	Single Family Residential
19 118847 RK	RRT-10	Rural Resource Transition-10	Single Family Residential
20 102168 RK	R-9,600(PRD)	Residential 9,600 sq. ft.	SFR-Basic
20 105591 RK	R-9,600(PRD)	Residential 9,600 sq. ft.	SFR-Basic
20 102167 RK	R-9,600(PRD)	Residential 9,600 sq. ft.	SFR-Basic
20 102166 RK	R-9,600(PRD)	Residential 9,600 sq. ft.	SFR-Basic
20 102165 RK	R-9,600(PRD)	Residential 9,600 sq. ft.	SFR-Basic
20 102173 RK	R-9,600(PRD)	Residential 9,600 sq. ft.	SFR-Basic
20 105592 RK	R-9,600(PRD)	Residential 9,600 sq. ft.	SFR-Basic
20 103333 RK	R-7,200(PRD)	Residential 7,200 sq. ft.	SFR-Basic
20 103338 RK	R-7,200(PRD)	Residential 7,200 sq. ft.	SFR-Basic
20 103339 RK	R-7,200(PRD)	Residential 7,200 sq. ft.	SFR-Basic
20 108418 RK	R-7,200(PRD)	Residential 7,200 sq. ft.	SFR-Basic
20 108370 RK	R-7,200(PRD)	Residential 7,200 sq. ft.	SFR-Basic
20 110349 RK	R-7,200(PRD)	Residential 7,200 sq. ft.	SFR-Basic
20 110350 RK	R-7,200(PRD)	Residential 7,200 sq. ft.	SFR-Basic
20 105596 RK	R-7,200(PRD)	Residential 7,200 sq. ft.	SFR-Basic

Accessory Dwelling Units

Index # - File Name: 1.0022 - Single Family Dwellings Data\_Snohomish County.pdf

20 108415 RK	R-7,200(PRD)	Residential 7,200 sq. ft.	SFR-Basic
20 105594 RK	R-7,200(PRD)	Residential 7,200 sq. ft.	SFR-Basic
20 110141 RK	R-7,200(PRD)	Residential 7,200 sq. ft.	SFR-Basic
20 110145 RK	R-7,200(PRD)	Residential 7,200 sq. ft.	SFR-Basic
20 110146 RK	R-7,200(PRD)	Residential 7,200 sq. ft.	SFR-Basic
20 110149 RK	R-7,200(PRD)	Residential 7,200 sq. ft.	SFR-Basic
20 105593 RK	R-7,200(PRD)	Residential 7,200 sq. ft.	SFR-Basic
20 105595 RK	R-7,200(PRD)	Residential 7,200 sq. ft.	SFR-Basic
19 118014 RK	R-5	Rural-5 Acre	SFR-Basic
19 117437 RK	A-10	Agriculture-10 Acre	Single Family Residential
19 118178 RK	R-5	Rural-5 Acre	Single Family Residential
19 117315 RK	R-5	Rural-5 Acre	Single Family Residential
19 118302 RK	R-7,200	Residential 7,200 sq. ft.	Single Family Residential
19 118303 RK	R-7,200	Residential 7,200 sq. ft.	Single Family Residential
19 118305 RK	R-7,200	Residential 7,200 sq. ft.	Single Family Residential
19 118306 RK	R-7,200	Residential 7,200 sq. ft.	Single Family Residential
19 118307 RK	R-7,200	Residential 7,200 sq. ft.	Single Family Residential
19 118308 RK	R-7,200	Residential 7,200 sq. ft.	Single Family Residential
20 100054 RK	R-7,200	Residential 7,200 sq. ft.	Duplex-Basic
20 105495 RK	R-7,200	Residential 7,200 sq. ft.	Duplex-Basic
20 100053 RK	R-7,200	Residential 7,200 sq. ft.	Duplex-Basic
20 105494 RK	R-7,200	Residential 7,200 sq. ft.	Duplex-Basic
20 105492 RK	R-7,200	Residential 7,200 sq. ft.	Duplex-Basic
20 100014 RK	R-7,200	Residential 7,200 sq. ft.	Duplex-Basic
20 100998 RK	R-7,200	Residential 7,200 sq. ft.	Duplex-Basic
20 105488 RK	R-7,200	Residential 7,200 sq. ft.	Duplex-Basic
20 105489 RK	R-7,200	Residential 7,200 sq. ft.	Duplex-Basic
20 101892 RK	R-7,200	Residential 7,200 sq. ft.	Single Family Residential
20 106838 RK	A-10 : R-5	Agriculture-10 Acre : Rural-5	SFR-Basic
20 106839 RK	R-5	Rural-5 Acre	SFR-Basic
20 100950 RK	R-5	Rural-5 Acre	SFR-Basic
20 100935 RK	R-5	Rural-5 Acre	SFR-Basic
20 106840 RK	R-5	Rural-5 Acre	SFR-Basic
20 106841 RK	R-5	Rural-5 Acre	SFR-Basic
20 100952 RK	R-5	Rural-5 Acre	SFR-Basic
20 101948 RK	R-5	Rural-5 Acre	SFR-Basic
20 100945 RK	R-5	Rural-5 Acre	SFR-Basic
20 101950 RK	R-5	Rural-5 Acre	SFR-Basic
20 101952 RK	R-5	Rural-5 Acre	SFR-Basic
20 101953 RK	R-5	Rural-5 Acre	SFR-Basic
20 101951 RK	R-5	Rural-5 Acre	SFR-Basic
20 107268 RK	R-5	Rural-5 Acre	SFR-Basic
20 106843 RK	R-5	Rural-5 Acre	SFR-Basic
20 100937 RK	R-5	Rural-5 Acre	SFR-Basic
20 100956 RK	R-5	Rural-5 Acre	SFR-Basic
20 107269 RK	R-5	Rural-5 Acre	SFR-Basic
20 102918 RK	R-5	Rural-5 Acre	Single Family Residential

Accessory Dwelling Units

Index # - File Name: 1.0022 - Single Family Dwellings Data\_Snohomish County.pdf

20 102969 RK	R-5	Rural-5 Acre	Single Family Residential
20 102966 RK	R-5	Rural-5 Acre	Single Family Residential
20 102964 RK	R-5	Rural-5 Acre	Single Family Residential
20 102924 RK	R-5	Rural-5 Acre	Single Family Residential
20 102965 RK	R-5	Rural-5 Acre	Single Family Residential
20 102967 RK	R-5	Rural-5 Acre	Single Family Residential
20 102968 RK	R-5	Rural-5 Acre	Single Family Residential
20 102970 RK	R-5	Rural-5 Acre	Single Family Residential
20 100148 RK	R-5	Rural-5 Acre	Single Family Residential
20 100885 RK	R-7,200	Residential 7,200 sq. ft.	SFR-Basic
20 100922 RK	R-7,200	Residential 7,200 sq. ft.	SFR-Basic
20 102463 RK	R-7,200	Residential 7,200 sq. ft.	SFR-Basic
20 102467 RK	R-7,200	Residential 7,200 sq. ft.	SFR-Basic
20 102464 RK	R-7,200	Residential 7,200 sq. ft.	SFR-Basic
20 102465 RK	R-7,200	Residential 7,200 sq. ft.	SFR-Basic
20 102466 RK	R-7,200	Residential 7,200 sq. ft.	SFR-Basic
20 100930 RK	R-7,200	Residential 7,200 sq. ft.	SFR-Basic
20 102350 RK	R-7,200	Residential 7,200 sq. ft.	SFR-Basic
20 112027 RK	LDMR	Low Density Multiple Reside	SFR-Basic
20 108135 RK	LDMR	Low Density Multiple Reside	SFR-Basic
20 108137 RK	LDMR	Low Density Multiple Reside	SFR-Basic
20 108138 RK	LDMR	Low Density Multiple Reside	SFR-Basic
20 108139 RK	LDMR	Low Density Multiple Reside	SFR-Basic
20 108140 RK	LDMR	Low Density Multiple Reside	SFR-Basic
20 109080 RK	LDMR	Low Density Multiple Reside	SFR-Basic
20 109081 RK	LDMR	Low Density Multiple Reside	SFR-Basic
20 109082 RK	LDMR	Low Density Multiple Reside	SFR-Basic
20 109083 RK	LDMR	Low Density Multiple Reside	SFR-Basic
20 109084 RK	LDMR	Low Density Multiple Reside	SFR-Basic
20 105813 MH	R-12,500	Residential 12,500 sq. ft.	Mobile/Manufactured Home
20 106150 RK	R-5	Rural-5 Acre	SFR-Basic
20 106153 RK	R-5	Rural-5 Acre	SFR-Basic
20 106154 RK	R-5	Rural-5 Acre	SFR-Basic
20 106155 RK	R-5	Rural-5 Acre	SFR-Basic
20 106158 RK	R-5	Rural-5 Acre	SFR-Basic
20 106159 RK	R-5	Rural-5 Acre	SFR-Basic
20 106162 RK	R-5	Rural-5 Acre	SFR-Basic
20 106844 RK	R-5	Rural-5 Acre	SFR-Basic
20 104472 RK	R-7,200	Residential 7,200 sq. ft.	SFR-Basic
20 104485 RK	R-7,200	Residential 7,200 sq. ft.	SFR-Basic
20 104490 RK	R-7,200	Residential 7,200 sq. ft.	SFR-Basic
20 104492 RK	R-7,200	Residential 7,200 sq. ft.	SFR-Basic
20 104493 RK	R-7,200	Residential 7,200 sq. ft.	SFR-Basic
20 107018 RK	R-9,600	Residential 9,600 sq. ft.	Duplex-Basic
20 110081 RK	CITY : R-9,600	City : Residential 9,600 sq. ft	SFR-Basic
20 110080 RK	CITY : R-9,600	City : Residential 9,600 sq. ft	SFR-Basic
20 109086 RK	LDMR	Low Density Multiple Reside	SFR-Basic

Accessory Dwelling Units

Index # - File Name: 1.0022 - Single Family Dwellings Data\_Snohomish County.pdf

20 110557 RK	LDMR	Low Density Multiple Reside SFR-Basic	
20 109087 RK	LDMR	Low Density Multiple Reside SFR-Basic	
20 109088 RK	LDMR	Low Density Multiple Reside SFR-Basic	
20 109089 RK	LDMR	Low Density Multiple Reside SFR-Basic	
20 103546 RK	LDMR	Low Density Multiple Reside SFR-Basic	
20 103550 RK	LDMR	Low Density Multiple Reside SFR-Basic	
20 103549 RK	LDMR	Low Density Multiple Reside SFR-Basic	
20 103548 RK	LDMR	Low Density Multiple Reside SFR-Basic	
20 103547 RK	LDMR	Low Density Multiple Reside SFR-Basic	
20 103725 RK	LDMR	Low Density Multiple Reside SFR-Basic	
20 103732 RK	LDMR	Low Density Multiple Reside SFR-Basic	
20 103734 RK	LDMR	Low Density Multiple Reside SFR-Basic	
20 110558 RK	LDMR	Low Density Multiple Reside SFR-Basic	
20 109090 RK	LDMR	Low Density Multiple Reside SFR-Basic	
20 110560 RK	LDMR	Low Density Multiple Reside SFR-Basic	
20 110561 RK	LDMR	Low Density Multiple Reside SFR-Basic	
20 110563 RK	LDMR	Low Density Multiple Reside SFR-Basic	
20 110562 RK	LDMR	Low Density Multiple Reside SFR-Basic	
20 103757 RK	LDMR	Low Density Multiple Reside SFR-Basic	
19 117986 RK	LDMR	Low Density Multiple Reside SFR-Basic	
19 117987 RK	LDMR	Low Density Multiple Reside SFR-Basic	
20 106034 RK			Single Family Residential
20 106044 RK			Single Family Residential
20 106048 RK			Single Family Residential
20 106970 RK			Single Family Residential
20 106079 RK			Single Family Residential
20 106282 RK			Single Family Residential
20 106050 RK	R-5	Rural-5 Acre	Single Family Residential
20 108344 RK			Single Family Residential
20 108426 RK			Single Family Residential
19 116548 RK	R-5	Rural-5 Acre	Single Family Residential
20 101594 RK	R-9,600	Residential 9,600 sq. ft.	Single Family Residential
19 117153 RK	R-5	Rural-5 Acre	Single Family Residential
19 115277 RK	R-7,200(PRD)	Residential 7,200 sq. ft.	SFR-Basic
19 115279 RK	R-7,200(PRD)	Residential 7,200 sq. ft.	SFR-Basic
20 100134 RK	R-7,200(PRD)	Residential 7,200 sq. ft.	SFR-Basic
20 100135 RK	R-7,200(PRD)	Residential 7,200 sq. ft.	SFR-Basic
20 100919 RK	R-7,200(PRD)	Residential 7,200 sq. ft.	SFR-Basic
19 114726 RK	R-5	Rural-5 Acre	Single Family Residential
19 114684 RK	A-10	Agriculture-10 Acre	Single Family Residential
20 101866 RK	R-7200(PRD)_	Residential 7,200 sq. ft.	SFR-Basic
20 101867 RK	R-7200(PRD)_	Residential 7,200 sq. ft.	SFR-Basic
20 101869 RK	R-7200(PRD)_	Residential 7,200 sq. ft.	SFR-Basic
20 107484 RK	R-7200(PRD)_	Residential 7,200 sq. ft.	SFR-Basic
20 107483 RK	R-7200(PRD)_	Residential 7,200 sq. ft.	SFR-Basic
20 105663 RK	R-7200(PRD)_	Residential 7,200 sq. ft.	SFR-Basic
20 105664 RK	R-7200(PRD)_	Residential 7,200 sq. ft.	SFR-Basic

Accessory Dwelling Units

Index # - File Name: 1.0022 - Single Family Dwellings Data\_Snohomish County.pdf

20 105665 RK	R-7200(PRD)_ Residential 7,200 sq. ft.	SFR-Basic
20 105666 RK	R-7200(PRD)_ Residential 7,200 sq. ft.	SFR-Basic
20 101870 RK	R-7200(PRD)_ Residential 7,200 sq. ft.	SFR-Basic
20 101871 RK	R-7200(PRD)_ Residential 7,200 sq. ft.	SFR-Basic
20 101872 RK	R-7200(PRD)_ Residential 7,200 sq. ft.	SFR-Basic
20 101925 RK	R-7200(PRD)_ Residential 7,200 sq. ft.	SFR-Basic
19 118600 RK	R-7200(PRD)_ Residential 7,200 sq. ft.	SFR-Basic
20 100080 RK	R-9,600(PRD) Residential 9,600 sq. ft.	SFR-Basic
20 100229 RK	R-7,200(PRD) Residential 7,200 sq. ft.	SFR-Basic
20 100232 RK	R-7,200(PRD) Residential 7,200 sq. ft.	SFR-Basic
20 100233 RK	R-7,200(PRD) Residential 7,200 sq. ft.	SFR-Basic
20 100226 RK	R-7,200(PRD) Residential 7,200 sq. ft.	SFR-Basic
20 100224 RK	R-7,200(PRD) Residential 7,200 sq. ft.	SFR-Basic
20 100225 RK	R-7,200(PRD) Residential 7,200 sq. ft.	SFR-Basic
20 100221 RK	R-7,200(PRD) Residential 7,200 sq. ft.	SFR-Basic
20 100223 RK	R-7,200(PRD) Residential 7,200 sq. ft.	SFR-Basic
20 100206 RK	R-7,200(PRD) Residential 7,200 sq. ft.	SFR-Basic
20 100222 RK	R-7,200(PRD) Residential 7,200 sq. ft.	SFR-Basic
20 100227 RK	R-7,200(PRD) Residential 7,200 sq. ft.	SFR-Basic
20 100228 RK	R-7,200(PRD) Residential 7,200 sq. ft.	SFR-Basic
20 100231 RK	R-7,200(PRD) Residential 7,200 sq. ft.	SFR-Basic
20 100230 RK	R-7,200(PRD) Residential 7,200 sq. ft.	SFR-Basic
20 100234 RK	R-7,200(PRD) Residential 7,200 sq. ft.	SFR-Basic
20 101920 RK	R-7,200(PRD) Residential 7,200 sq. ft.	SFR-Basic
20 101921 RK	R-7,200(PRD) Residential 7,200 sq. ft.	SFR-Basic
20 103421 RK	R-7,200(PRD) Residential 7,200 sq. ft.	SFR-Basic
20 104505 RK	R-7,200(PRD) Residential 7,200 sq. ft.	SFR-Basic
20 109485 RK	R-7,200(PRD) Residential 7,200 sq. ft.	SFR-Basic
20 109490 RK	R-7,200(PRD) Residential 7,200 sq. ft.	SFR-Basic
20 109492 RK	R-7,200(PRD) Residential 7,200 sq. ft.	SFR-Basic
20 109486 RK	R-7,200(PRD) Residential 7,200 sq. ft.	SFR-Basic
20 108338 RK	R-7,200(PRD) Residential 7,200 sq. ft.	SFR-Basic
20 104506 RK	R-7,200(PRD) Residential 7,200 sq. ft.	SFR-Basic
20 101922 RK	R-7,200(PRD) Residential 7,200 sq. ft.	SFR-Basic
20 101924 RK	R-7,200(PRD) Residential 7,200 sq. ft.	SFR-Basic
20 101929 RK	R-7,200(PRD) Residential 7,200 sq. ft.	SFR-Basic
20 101931 RK	R-7,200(PRD) Residential 7,200 sq. ft.	SFR-Basic
20 101935 RK	R-7,200(PRD) Residential 7,200 sq. ft.	SFR-Basic
20 101936 RK	R-7,200(PRD) Residential 7,200 sq. ft.	SFR-Basic
20 103423 RK	R-7,200(PRD) Residential 7,200 sq. ft.	SFR-Basic
20 104508 RK	R-7,200(PRD) Residential 7,200 sq. ft.	SFR-Basic
20 109484 RK	R-7,200(PRD) Residential 7,200 sq. ft.	SFR-Basic
20 104510 RK	R-7,200(PRD) Residential 7,200 sq. ft.	SFR-Basic
20 108339 RK	R-7,200(PRD) Residential 7,200 sq. ft.	SFR-Basic
20 109493 RK	R-7,200(PRD) Residential 7,200 sq. ft.	SFR-Basic
20 109489 RK	R-7,200(PRD) Residential 7,200 sq. ft.	SFR-Basic
20 103420 RK	R-7,200(PRD) Residential 7,200 sq. ft.	SFR-Basic



Accessory Dwelling Units

Index # - File Name: 1.0022 - Single Family Dwellings Data\_Snohomish County.pdf

20 101903 RK	R-7,200(PRD)	Residential 7,200 sq. ft.	SFR-Basic
19 117895 RK	R-7,200(PRD)	Residential 7,200 sq. ft.	SFR-Basic
20 104201 RK	R-7,200(PRD)	Residential 7,200 sq. ft.	SFR-Basic
20 103482 RK	R-7,200(PRD)	Residential 7,200 sq. ft.	SFR-Basic
20 103483 RK	R-7,200(PRD)	Residential 7,200 sq. ft.	SFR-Basic
20 103497 RK	R-7,200(PRD)	Residential 7,200 sq. ft.	SFR-Basic
20 103498 RK	R-7,200(PRD)	Residential 7,200 sq. ft.	SFR-Basic
19 114590 RK	LDMR	Low Density Multiple Reside	Single Family Residential
19 118494 RK	R-7,200(PRD)	Residential 7,200 sq. ft.	Single Family Residential
20 102327 RK	R-7,200(PRD)	Residential 7,200 sq. ft.	Single Family Residential
19 114833 RK	LDMR	Low Density Multiple Reside	Single Family Residential
19 115632 RK	LDMR	Low Density Multiple Reside	Single Family Residential
19 115640 RK	LDMR	Low Density Multiple Reside	Single Family Residential
19 115621 RK	LDMR	Low Density Multiple Reside	Single Family Residential
20 100090 RK	R-9,600(PRD)	Residential 9,600 sq. ft.	SFR-Basic
20 106887 RK	R-5	Rural-5 Acre	SFR-Basic
20 106888 RK	R-5	Rural-5 Acre	SFR-Basic
19 117472 RK	R-7,200	Residential 7,200 sq. ft.	Duplex-Basic
19 117760 RK	R-5	Rural-5 Acre	Single Family Residential
19 112374 RK	R-5	Rural-5 Acre	Single Family Residential
20 107457 RK	R-5	Rural-5 Acre	Single Family Residential
20 100041 MH	R-5	Rural-5 Acre	Mobile/Manufactured Home
20 101008 RK	R-5	Rural-5 Acre	Single Family Residential
20 102330 RK	R-5	Rural-5 Acre	Single Family Residential
20 102086 RK	R-5	Rural-5 Acre	SFR-Basic
20 101761 RK	R-5	Rural-5 Acre	SFR-Basic
20 101146 RK	R-5	Rural-5 Acre	SFR-Basic
20 106023 RK	R-5	Rural-5 Acre	SFR-Basic
20 110413 RK	R-5	Rural-5 Acre	SFR-Basic
19 118559 RK	LDMR	Low Density Multiple Reside	SFR-Basic
19 118560 RK	LDMR	Low Density Multiple Reside	SFR-Basic
19 118561 RK	LDMR	Low Density Multiple Reside	SFR-Basic
20 100067 RK	LDMR	Low Density Multiple Reside	SFR-Basic
20 100066 RK	LDMR	Low Density Multiple Reside	SFR-Basic
19 118514 RK	R-7,200(PRD)	Residential 7,200 sq. ft.	SFR-Basic
19 118515 RK	R-7,200(PRD)	Residential 7,200 sq. ft.	SFR-Basic
20 100065 RK	R-7,200(PRD)	Residential 7,200 sq. ft.	SFR-Basic
20 100063 RK	R-7,200(PRD)	Residential 7,200 sq. ft.	SFR-Basic
19 118518 RK	R-7,200(PRD)	Residential 7,200 sq. ft.	SFR-Basic
19 118517 RK	R-7,200(PRD)	Residential 7,200 sq. ft.	SFR-Basic
19 117918 RK	LDMR	Low Density Multiple Reside	Single Family Residential
20 102192 RK	R-7,200	Residential 7,200 sq. ft.	SFR-Basic
20 102189 RK	R-7,200	Residential 7,200 sq. ft.	SFR-Basic
19 118573 RK	R-7,200	Residential 7,200 sq. ft.	SFR-Basic
20 102211 RK	R-7,200	Residential 7,200 sq. ft.	SFR-Basic
20 102213 RK	R-7,200	Residential 7,200 sq. ft.	SFR-Basic
19 118572 RK	R-7,200	Residential 7,200 sq. ft.	SFR-Basic

Accessory Dwelling Units

Index # - File Name: 1.0022 - Single Family Dwellings Data\_Snohomish County.pdf

19 118571 RK	R-7,200	Residential 7,200 sq. ft.	SFR-Basic
20 100128 RK	R-7,200	Residential 7,200 sq. ft.	SFR-Basic
20 103180 RK	R-5	Rural-5 Acre	Single Family Residential
19 112827 RK	R-5	Rural-5 Acre	Single Family Residential
20 104071 RK	R-5	Rural-5 Acre	Single Family Residential
20 104273 RK	R-5	Rural-5 Acre	Single Family Residential
19 117846 RK	LDMR	Low Density Multiple Reside	Single Family Residential
19 117849 RK	LDMR	Low Density Multiple Reside	Single Family Residential
19 117851 RK	LDMR	Low Density Multiple Reside	Single Family Residential
20 102674 RK	LDMR	Low Density Multiple Reside	Single Family Residential
20 103211 RK	LDMR	Low Density Multiple Reside	Single Family Residential
20 102767 RK	LDMR	Low Density Multiple Reside	Single Family Residential
20 102785 RK	LDMR	Low Density Multiple Reside	Single Family Residential
20 104094 RK	LDMR	Low Density Multiple Reside	Single Family Residential
20 104496 RK	LDMR	Low Density Multiple Reside	Single Family Residential
20 104358 RK	LDMR	Low Density Multiple Reside	Single Family Residential
20 104362 RK	LDMR	Low Density Multiple Reside	Single Family Residential
20 104501 RK	LDMR	Low Density Multiple Reside	Single Family Residential
20 104516 RK	LDMR	Low Density Multiple Reside	Single Family Residential
20 105631 RK	LDMR	Low Density Multiple Reside	Single Family Residential
20 105633 RK	LDMR	Low Density Multiple Reside	Single Family Residential
20 105636 RK	LDMR	Low Density Multiple Reside	Single Family Residential
20 106075 RK	LDMR	Low Density Multiple Reside	Single Family Residential
19 118895 MH	R-12,500	Residential 12,500 sq. ft.	Mobile/Manufactured Home
20 103197 RK	R-7,200	Residential 7,200 sq. ft.	SFR-Basic
20 103212 RK	R-7,200	Residential 7,200 sq. ft.	SFR-Basic
20 103215 RK	R-7,200	Residential 7,200 sq. ft.	SFR-Basic
20 103226 RK	R-7,200	Residential 7,200 sq. ft.	SFR-Basic
20 103227 RK	R-7,200	Residential 7,200 sq. ft.	SFR-Basic
20 102206 RK	R-7,200	Residential 7,200 sq. ft.	SFR-Basic
20 102231 RK	R-7,200	Residential 7,200 sq. ft.	SFR-Basic
20 102185 RK	R-7,200	Residential 7,200 sq. ft.	SFR-Basic
20 100130 RK	R-7,200	Residential 7,200 sq. ft.	SFR-Basic
20 100133 RK	R-7,200	Residential 7,200 sq. ft.	SFR-Basic
20 102247 RK	R-7,200	Residential 7,200 sq. ft.	SFR-Basic
20 100095 RK	R-7,200	Residential 7,200 sq. ft.	SFR-Basic
19 118319 RK	R-5	Rural-5 Acre	Single Family Residential
19 115038 RK	R-5	Rural-5 Acre	Single Family Residential
19 118644 RK	R-7,200	Residential 7,200 sq. ft.	SFR-Basic
20 101194 RK	R-5	Rural-5 Acre	SFR-Basic
20 101093 RK	R-5	Rural-5 Acre	SFR-Basic
20 104590 RK	R-5	Rural-5 Acre	Single Family Residential
20 105496 RK	R-5	Rural-5 Acre	Single Family Residential
20 103876 RK	R-5	Rural-5 Acre	Single Family Residential
20 106251 RK	R-5	Rural-5 Acre	Single Family Residential
20 104615 RK	R-5	Rural-5 Acre	Single Family Residential
20 101122 RK	R-5	Rural-5 Acre	Single Family Residential

Accessory Dwelling Units

Index # - File Name: 1.0022 - Single Family Dwellings Data\_Snohomish County.pdf

19 117715 RK	R-5	Rural-5 Acre	Single Family Residential
20 101713 RK	R-5	Rural-5 Acre	Single Family Residential
19 118850 RK	R-5	Rural-5 Acre	Single Family Residential
19 118646 RK	R-7,200	Residential 7,200 sq. ft.	SFR-Basic
19 118649 RK	R-7,200	Residential 7,200 sq. ft.	SFR-Basic
19 118648 RK			SFR-Basic
19 118655 RK	R-7,200	Residential 7,200 sq. ft.	SFR-Basic
20 100104 RK	R-7,200	Residential 7,200 sq. ft.	SFR-Basic
20 100106 RK	R-7,200	Residential 7,200 sq. ft.	SFR-Basic
20 102146 RK	R-7,200	Residential 7,200 sq. ft.	SFR-Basic
20 102245 RK	R-7,200	Residential 7,200 sq. ft.	SFR-Basic
20 102246 RK	R-7,200	Residential 7,200 sq. ft.	SFR-Basic
20 103416 RK	R-7,200	Residential 7,200 sq. ft.	SFR-Basic
20 103419 RK	R-7,200	Residential 7,200 sq. ft.	SFR-Basic
20 103586 RK	R-7,200	Residential 7,200 sq. ft.	SFR-Basic
20 103617 RK	R-7,200	Residential 7,200 sq. ft.	SFR-Basic
20 103411 RK	R-7,200	Residential 7,200 sq. ft.	SFR-Basic
20 102147 RK	R-7,200	Residential 7,200 sq. ft.	SFR-Basic
20 105395 RK	R-7,200	Residential 7,200 sq. ft.	SFR-Basic
20 105396 RK	R-7,200	Residential 7,200 sq. ft.	SFR-Basic
20 102667 RK	R-7,200	Residential 7,200 sq. ft.	SFR-Basic
20 103621 RK	R-7,200	Residential 7,200 sq. ft.	SFR-Basic
20 103629 RK	R-7,200	Residential 7,200 sq. ft.	SFR-Basic
20 105399 RK	R-7,200	Residential 7,200 sq. ft.	SFR-Basic
20 105397 RK	R-7,200	Residential 7,200 sq. ft.	SFR-Basic
20 105401 RK	R-7,200	Residential 7,200 sq. ft.	SFR-Basic
20 105394 RK	R-7,200	Residential 7,200 sq. ft.	SFR-Basic
20 105400 RK	R-7,200	Residential 7,200 sq. ft.	SFR-Basic
20 103630 RK	R-7,200	Residential 7,200 sq. ft.	SFR-Basic
20 102145 RK	R-7,200	Residential 7,200 sq. ft.	SFR-Basic
20 100125 RK	R-7,200	Residential 7,200 sq. ft.	SFR-Basic
20 100108 RK	R-7,200	Residential 7,200 sq. ft.	SFR-Basic
20 100099 RK	R-7,200	Residential 7,200 sq. ft.	SFR-Basic
20 100096 RK	R-7,200	Residential 7,200 sq. ft.	SFR-Basic
19 118652 RK	R-7,200	Residential 7,200 sq. ft.	SFR-Basic
19 118651 RK	R-7,200	Residential 7,200 sq. ft.	SFR-Basic
19 118647 RK	R-7,200	Residential 7,200 sq. ft.	SFR-Basic
20 105398 RK	R-7,200	Residential 7,200 sq. ft.	SFR-Basic
20 103413 RK	R-7,200	Residential 7,200 sq. ft.	SFR-Basic
20 100123 RK	R-7,200	Residential 7,200 sq. ft.	SFR-Basic
20 104342 RK	R-5	Rural-5 Acre	SFR-Basic
20 104341 RK	R-5	Rural-5 Acre	SFR-Basic
20 111590 RK	R-5	Rural-5 Acre	SFR-Basic
20 110113 RK	R-5	Rural-5 Acre	SFR-Basic
20 102546 RK	R-5	Rural-5 Acre	Single Family Residential
20 103761 RK	R-5	Rural-5 Acre	SFR-Basic
20 108713 RK	R-5	Rural-5 Acre	SFR-Basic

Accessory Dwelling Units

Index # - File Name: 1.0022 - Single Family Dwellings Data\_Snohomish County.pdf

20 110687 RK	R-5	Rural-5 Acre	SFR-Basic
19 117547 RK	R-5	Rural-5 Acre	Single Family Residential
19 118504 RK	MR	Multiple Residential	SFR-Basic
20 102149 RK	MR	Multiple Residential	SFR-Basic
20 100059 RK	MR	Multiple Residential	SFR-Basic
19 104146 RK	R-5	Rural-5 Acre	Single Family Residential
20 100162 RK	R-5	Rural-5 Acre	Single Family Residential
19 106436 RK	R-5	Rural-5 Acre	Single Family Residential
20 101314 RK	R-5	Rural-5 Acre	Single Family Residential
20 102995 RK	R-5	Rural-5 Acre	SFR-Basic
20 102963 RK	R-5	Rural-5 Acre	SFR-Basic
19 118503 RK	MR	Multiple Residential	SFR-Basic
19 118502 RK	MR	Multiple Residential	SFR-Basic
20 100060 RK	MR	Multiple Residential	SFR-Basic
20 100062 RK	MR	Multiple Residential	SFR-Basic
20 102144 RK	MR	Multiple Residential	SFR-Basic
20 102148 RK	MR	Multiple Residential	SFR-Basic
20 102150 RK	MR	Multiple Residential	SFR-Basic
19 118497 RK	LDMR	Low Density Multiple Reside	SFR-Basic
20 104149 RK	R-5	Rural-5 Acre	SFR-Basic
19 117700 RK	R-5	Rural-5 Acre	SFR-Basic
19 117699 RK	R-5	Rural-5 Acre	SFR-Basic
20 103826 RK	R-5	Rural-5 Acre	SFR-Basic
19 104090 RK	R-5	Rural-5 Acre	Single Family Residential
19 104574 RK	R-5	Rural-5 Acre	Single Family Residential
20 105477 RK	R-5	Rural-5 Acre	Single Family Residential
19 118777 RK	R-7,200(PRD)	Residential 7,200 sq. ft.	SFR-Basic
19 117383 RK	R-7,200(PRD)	Residential 7,200 sq. ft.	SFR-Basic
19 115018 RK	R-7,200	Residential 7,200 sq. ft.	Single Family Residential
19 117384 RK	R-7,200(PRD)	Residential 7,200 sq. ft.	SFR-Basic
19 110304 RK	R-7,200	Residential 7,200 sq. ft.	Single Family Residential
19 112944 RK	R-5	Rural-5 Acre	Single Family Residential
19 118778 RK	R-7,200(PRD)	Residential 7,200 sq. ft.	SFR-Basic
19 118008 RK	BP	Business Park	SFR-Basic
20 101697 RK	R-5	Rural-5 Acre	Single Family Residential
20 103756 RK	R-5	Rural-5 Acre	Single Family Residential
19 114738 RK	R-5	Rural-5 Acre	SFR-Basic
20 103013 RK	R-5	Rural-5 Acre	SFR-Basic
20 103014 RK	R-5	Rural-5 Acre	SFR-Basic
20 109593 RK	R-5	Rural-5 Acre	SFR-Basic
20 109596 RK	R-5	Rural-5 Acre	SFR-Basic
20 102977 RK	R-5	Rural-5 Acre	SFR-Basic
19 110510 RK	R-5	Rural-5 Acre	Single Family Residential
20 103673 RK	R-5	Rural-5 Acre	Single Family Residential
20 101018 RK	R-7,200	Residential 7,200 sq. ft.	Single Family Residential
19 117071 RK	R-9,600	Residential 9,600 sq. ft.	Single Family Residential
20 104318 RK	R-5	Rural-5 Acre	Single Family Residential

Accessory Dwelling Units

Index # - File Name: 1.0022 - Single Family Dwellings Data\_Snohomish County.pdf

19 111018 RK	R-5	Rural-5 Acre	Single Family Residential
19 117546 RK	R-5	Rural-5 Acre	Single Family Residential
20 104004 RK	R-5	Rural-5 Acre	Single Family Residential
20 103978 RK	R-5	Rural-5 Acre	Single Family Residential
20 104002 RK	R-5	Rural-5 Acre	Single Family Residential
20 104000 RK	R-5	Rural-5 Acre	Single Family Residential
19 100729 RK	LDMR	Low Density Multiple Reside	Single Family Residential
18 151675 RK	LDMR	Low Density Multiple Reside	Single Family Residential
18 151684 RK	LDMR	Low Density Multiple Reside	Single Family Residential
18 151687 RK	LDMR	Low Density Multiple Reside	Single Family Residential
18 151689 RK	LDMR	Low Density Multiple Reside	Single Family Residential
20 103162 RK	R-5	Rural-5 Acre	SFR-Basic
19 112379 RK	R-5	Rural-5 Acre	SFR-Basic
20 103174 RK	R-5	Rural-5 Acre	SFR-Basic
20 103145 RK	R-5	Rural-5 Acre	SFR-Basic
19 109299 RK	R-5	Rural-5 Acre	SFR-Basic
20 106247 RK	R-5	Rural-5 Acre	SFR-Basic
19 106275 RK	R-5	Rural-5 Acre	Single Family Residential
19 118702 RK	LDMR : R-7,20 Low Density Multiple Reside SFR-Basic		
19 118703 RK	LDMR : R-7,20 Low Density Multiple Reside SFR-Basic		
19 118705 RK	LDMR : R-7,20 Low Density Multiple Reside SFR-Basic		
19 118704 RK	LDMR : R-7,20 Low Density Multiple Reside SFR-Basic		
19 107079 RK	R-5	Rural-5 Acre	Single Family Residential
19 113238 RK	R-5	Rural-5 Acre	SFR-Basic
19 113531 RK	RD	Rural Diversification	Single Family Residential
19 113835 RK	R-5	Rural-5 Acre	SFR-Basic
19 113838 RK	R-5	Rural-5 Acre	SFR-Basic
19 116917 RK	R-5	Rural-5 Acre	SFR-Basic
19 113845 RK	R-5	Rural-5 Acre	SFR-Basic
19 114736 RK	R-5	Rural-5 Acre	SFR-Basic
20 102531 RK	R-7,200	Residential 7,200 sq. ft.	SFR-Basic
20 102982 RK	R-5	Rural-5 Acre	SFR-Basic
20 103010 RK	R-5	Rural-5 Acre	SFR-Basic
20 103026 RK	R-5	Rural-5 Acre	SFR-Basic
20 102998 RK	R-5	Rural-5 Acre	SFR-Basic
19 118931 RK	R-7,200	Residential 7,200 sq. ft.	Single Family Residential
19 110297 RK	R-7,200	Residential 7,200 sq. ft.	Single Family Residential
20 103320 RK	R-5	Rural-5 Acre	Single Family Residential
19 116560 RK	R-5	Rural-5 Acre	Single Family Residential
20 103461 RK	R-5	Rural-5 Acre	Single Family Residential
19 118105 RK	LDMR : R-7,20 Low Density Multiple Reside SFR-Basic		
20 102154 RK	LDMR	Low Density Multiple Reside	SFR-Basic
20 102153 RK	LDMR	Low Density Multiple Reside	SFR-Basic
19 114737 RK	R-5	Rural-5 Acre	SFR-Basic
19 117385 RK	R-5	Rural-5 Acre	Single Family Residential
19 118473 RK	R-5	Rural-5 Acre	Single Family Residential
19 114720 RK	R-5	Rural-5 Acre	SFR-Basic

Accessory Dwelling Units

Index # - File Name: 1.0022 - Single Family Dwellings Data\_Snohomish County.pdf

20 102512 RK	R-5	Rural-5 Acre	SFR-Basic
19 118825 RK	R-5	Rural-5 Acre	Single Family Residential
20 106642 RK	R-5	Rural-5 Acre	Single Family Residential
19 118161 RK	R-5	Rural-5 Acre	Single Family Residential
20 101049 RK	RC	Rural Conservation	Single Family Residential
19 113833 RK	F	Forestry	SFR-Basic
19 116698 RK	R-5	Rural-5 Acre	Single Family Residential
19 114223 MH	R-5	Rural-5 Acre	Mobile/Manufactured Home
20 107857 RK	R-5	Rural-5 Acre	Single Family Residential
19 115306 RK	R-7,200(PRD)	Residential 7,200 sq. ft.	Accessory Apt Attached
18 151942 RK	LDMR	Low Density Multiple Reside	Single Family Residential
18 151656 RK	WFB	Waterfront Beach	Single Family Residential
20 103828 RK	R-5	Rural-5 Acre	SFR-Basic
20 107271 RK	R-5	Rural-5 Acre	SFR-Basic
20 103823 RK	R-5	Rural-5 Acre	SFR-Basic
20 106807 RK	R-5	Rural-5 Acre	SFR-Basic
20 103827 RK	R-5	Rural-5 Acre	SFR-Basic
20 107272 RK	R-5	Rural-5 Acre	SFR-Basic
19 106298 MH	A-10	Agriculture-10 Acre	Mobile/Manufactured Home
20 108368 RK	R-5	Rural-5 Acre	SFR-Basic
20 111043 RK	R-5	Rural-5 Acre	SFR-Basic
19 118104 RK	R-5	Rural-5 Acre	SFR-Basic
19 118087 RK	R-5	Rural-5 Acre	SFR-Basic
19 118072 RK	R-5	Rural-5 Acre	SFR-Basic
19 118070 RK	R-5	Rural-5 Acre	SFR-Basic
19 118007 RK	R-5	Rural-5 Acre	SFR-Basic
19 118009 RK	R-5	Rural-5 Acre	SFR-Basic
19 118897 MH	R-12,500	Residential 12,500 sq. ft.	Mobile/Manufactured Home
19 110650 RK	R-5	Rural-5 Acre	Single Family Residential
20 104044 RK	R-5	Rural-5 Acre	Single Family Residential
19 118751 RK	R-5	Rural-5 Acre	Single Family Residential
20 103875 RK	R-5	Rural-5 Acre	Single Family Residential
20 104286 MH	R-5	Rural-5 Acre	Mobile/Manufactured Home
20 106077 RK	R-5	Rural-5 Acre	Single Family Residential
20 106109 RK	R-5	Rural-5 Acre	Single Family Residential
20 103867 MH	MHP	Mobile Home Park	Mobile/Manufactured Home in Park
20 110015 MH	MHP	Mobile Home Park	Mobile/Manufactured Home in Park
19 114037 RK	R-5	Rural-5 Acre	Accessory Apt Detached
19 113564 RK	R-5	Rural-5 Acre	Single Family Residential
19 113562 RK	R-5	Rural-5 Acre	Single Family Residential
19 113978 RK	R-5	Rural-5 Acre	Accessory Apt Detached
20 103796 MH	PRD-20,000(M	Residential 20,000 sq. ft. : R	Mobile/Manufactured Home in Park
20 103207 RK	R-5	Rural-5 Acre	Single Family Residential
20 103763 RK	R-5	Rural-5 Acre	Single Family Residential
19 105891 RK	A-10	Agriculture-10 Acre	Single Family Residential
20 101105 RK	R-5	Rural-5 Acre	Single Family Residential
20 108886 RK	R-5	Rural-5 Acre	Single Family Residential

Accessory Dwelling Units

Index # - File Name: 1.0022 - Single Family Dwellings Data\_Snohomish County.pdf

20 104422 RK	R-5	Rural-5 Acre	Single Family Residential
19 118908 RK	R-5	Rural-5 Acre	SFR-Basic
20 108443 RK	R-5	Rural-5 Acre	Single Family Residential
19 117653 MH	MHP	Mobile Home Park	Mobile/Manufactured Home in Park
19 118436 MH	MHP	Mobile Home Park	Mobile/Manufactured Home in Park
20 106720 RK	R-5	Rural-5 Acre	Single Family Residential
19 114689 RK	SA-1	Suburban Agriculture-1 Acre	Single Family Residential
19 114725 RK	R-5	Rural-5 Acre	Single Family Residential
19 115437 RK	R-5	Rural-5 Acre	Single Family Residential
19 117649 MH	MHP	Mobile Home Park	Mobile/Manufactured Home in Park
20 102726 RK	R-5	Rural-5 Acre	Single Family Residential
20 101516 RK	R-5	Rural-5 Acre	Single Family Residential
20 102565 MH	R-5	Rural-5 Acre	Mobile/Manufactured Home
20 100173 MH	R-5	Rural-5 Acre	Mobile/Manufactured Home
19 117163 RK	R-5	Rural-5 Acre	Single Family Residential
19 117135 RK	R-5	Rural-5 Acre	Single Family Residential
20 103116 RK	R-5	Rural-5 Acre	Single Family Residential
19 115029 RK	LDMR	Low Density Multiple Reside	Single Family Residential
20 104092 RK	R-5	Rural-5 Acre	Accessory Apt Detached
19 112230 RK	R-5	Rural-5 Acre	Single Family Residential
20 106905 RK	SA-1	Suburban Agriculture-1 Acre	Single Family Residential
19 114143 RK	R-9,600	Residential 9,600 sq. ft.	Duplex
20 102613 RK	R-5	Rural-5 Acre	Single Family Residential
19 118638 RK	R-7,200	Residential 7,200 sq. ft.	Duplex-Basic
19 116779 RK	R-5	Rural-5 Acre	Single Family Residential
19 119017 MH	R-12,500	Residential 12,500 sq. ft.	Mobile/Manufactured Home
20 104509 RK	WFB	Waterfront Beach	Duplex
19 114790 RK	R-5	Rural-5 Acre	Accessory Apt Detached
20 106793 RK	R-8,400	Residential 8,400 sq. ft.	Accessory Apt Detached
20 101515 RK	R-9,600	Residential 9,600 sq. ft.	Single Family Residential
19 117094 RK	R-5	Rural-5 Acre	Single Family Residential
20 102735 RK	R-8,400	Residential 8,400 sq. ft.	Duplex
20 103666 RK	R-5	Rural-5 Acre	Single Family Residential
19 118666 RK	R-5	Rural-5 Acre	Single Family Residential
19 110832 RK	R-5	Rural-5 Acre	Single Family Residential
20 100915 MH	LDMR	Low Density Multiple Reside	Mobile/Manufactured Home in Park
19 108655 RK	R-5	Rural-5 Acre	Single Family Residential
20 102194 RK	R-5	Rural-5 Acre	Single Family Residential
19 107831 RK	R-5	Rural-5 Acre	Single Family Residential
19 115819 RK	R-5	Rural-5 Acre	Single Family Residential
20 103951 RK	R-9,600	Residential 9,600 sq. ft.	Single Family Residential
19 114444 RK	R-5	Rural-5 Acre	Single Family Residential
20 107102 RK	R-5	Rural-5 Acre	Duplex
19 109285 RK	R-9,600	Residential 9,600 sq. ft.	Accessory Apt Detached
19 118002 RK	R-5	Rural-5 Acre	Single Family Residential
19 114257 RK	R-7,200	Residential 7,200 sq. ft.	Duplex
20 101706 RK	R-5	Rural-5 Acre	Single Family Residential

Accessory Dwelling Units

Index # - File Name: 1.0022 - Single Family Dwellings Data\_Snohomish County.pdf

19 110543 RK	R-5	Rural-5 Acre	Single Family Residential
20 102431 RK	R-5	Rural-5 Acre	Single Family Residential
19 118088 RK	R-5	Rural-5 Acre	Single Family Residential
20 104010 RK	R-5	Rural-5 Acre	Accessory Apt Detached
20 105652 RK	R-9,600	Residential 9,600 sq. ft.	Single Family Residential
20 103806 MH	R-5	Rural-5 Acre	Mobile/Manufactured Home
20 106560 MH	R-5	Rural-5 Acre	Single Wide
20 103000 RK	RRT-10	Rural Resource Transition-10	Single Family Residential
19 114669 RK	R-5	Rural-5 Acre	SFR-Basic
19 114676 RK	R-5	Rural-5 Acre	SFR-Basic
19 117412 RK	R-5	Rural-5 Acre	Single Family Residential
20 102110 RK	R-5	Rural-5 Acre	Single Family Residential
19 117151 MH	R-5	Rural-5 Acre	Mobile/Manufactured Home
20 105626 RK	R-5	Rural-5 Acre	Single Family Residential
19 112689 RK	R-5	Rural-5 Acre	Single Family Residential
20 105567 RK	R-5	Rural-5 Acre	Accessory Apt Detached
20 105453 RK	R-5	Rural-5 Acre	Single Family Residential
19 114196 MH	R-7,200	Residential 7,200 sq. ft.	Mobile/Manufactured Home
19 108177 RK	R-5	Rural-5 Acre	Single Family Residential
20 102094 RK	R-5	Rural-5 Acre	SFR-Basic
20 102056 RK	R-5	Rural-5 Acre	Accessory Apt Detached
19 115407 RK	R-5	Rural-5 Acre	Single Family Residential
19 110662 RK	A-10	Agriculture-10 Acre	Single Family Residential
19 117640 RK	R-5	Rural-5 Acre	Single Family Residential
19 115684 MH	R-5	Rural-5 Acre	Mobile/Manufactured Home
20 108551 MH	R-5	Rural-5 Acre	Mobile/Manufactured Home
19 116579 RK	R-5	Rural-5 Acre	Single Family Residential
19 113650 RK	R-5	Rural-5 Acre	Single Family Residential
19 118856 RK	R-5	Rural-5 Acre	Single Family Residential
20 105611 RK	R-5	Rural-5 Acre	Single Family Residential
19 118044 RK	RRT-10	Rural Resource Transition-10	Single Family Residential
19 114990 RK	R-5	Rural-5 Acre	Single Family Residential
19 115568 RK	R-5	Rural-5 Acre	Single Family Residential
19 118240 RK	R-5	Rural-5 Acre	Single Family Residential
19 115021 RK	R-5	Rural-5 Acre	Single Family Residential
19 118896 RK	R-5	Rural-5 Acre	Single Family Residential
20 103843 RK	R-5	Rural-5 Acre	Single Family Residential
20 103328 RK	R-5	Rural-5 Acre	Single Family Residential
20 104438 RK	R-5	Rural-5 Acre	Single Family Residential
19 114632 RK	R-5	Rural-5 Acre	Single Family Residential



Accessory Dwelling Units

Index # - File Name: 1.0022 - Single Family Dwellings Data\_Snohomish County.pdf

Work Description	Year
New SFR	1994
New SFR/GARAGE	1994
New B91-596 but to built without the attached garage (ok as per L. Andrews 12/15/94)	1994
New SFR constructed 1910 is guest house. Mobile home is primary residence.	1994
New SFR	1994
New SFR	1994
New SFR note: jrlenz confirmed with application on micro film this permit was for a duplex not a sfr.	1994
New Site & Water N/A MBHM on site pre-1982	1994
New SFR	1994
New SFR	1994
New SFR	1994
New SFR	1994
New MOBILE HOME	1994
New RESIDENCE/GARAGE	1994
New SFR	1994
New SFR	1994
New SFR / GARAGE	1994
New SFR	1994
New SFR - auto extended to 12/16/96	1994
New SFR	1994
New MOBILE HOME -	1994
New SFR / GARAGE / DECK	1994
New RESIDENCE/GARAGE	1994
New SFR	1994
New 0 lot line structure The Rose Plan B91-994	1994
New 0 lot line structure The Rose Plan B91-994	1994
New 0 lot line structure Tulip Plan Basic B91-1019	1994
New 0 lot line structure Plan Orchid Basic #B91-983	1994
New MOBILE HOME	1994
New SFR	1994
New SFR / GARAGE /	1994
New SFR	1994
New SFR	1994
New SFR, GARAGE	1994
New SFR, GARAGE	1994
New SFR	1994
New SFR, GARAGE	1994
New SFR	1994
New Builders Plan #1905 Basic B91-1042	1994
New Basic B91-1022	1994
New Basic B91-1027	1994
New Builder Plan #1399 Basic B91-150	1994
New Builder Plan #1399 Basic B91-150	1994
New Builders Plan #1905 Basic Number B91-1042	1994
New MOBILE HOME	1994
New CABIN	1994

Accessory Dwelling Units

Index # - File Name: 1.0022 - Single Family Dwellings Data\_Snohomish County.pdf

New	Westview Estates MH Park - Space 51	MOBILE HOME	1994
New	SFR / GARAGE / DECK		1994
New	Duplex		1995
New	SFR		1995
New	2 Story with a 3 car		1995
New	2 Story with a 2 car		1995
New	Rambler Style SFR - 1994	STOP WORK POSTED 12/21/95!!!	1995
New	Rambler Style SFR - 1994	UBC STOP WORK POSTED 12/21/95!!!!	1995
New	Rambler Style SFR - 1994	UBC STOP WORK POSTED 12/21/95!!!	1995
New	28 x 58 MH		1995
New	Rambler Style SFR - 1994	UBC	1995
New	1978	24 x 68 Port Royale	1995
New	2 Story with 2 car and unfinished bonus room above garage		1995
New	SFR- Rambler-	1994 UBC	1995
New	SFR Rambler-	1994 UBC	1995
New	1995	28 X 66 Marlett	1995
New	SFR		1995
New	1991	14 x 66 Liberty Oakhurst	1995
New	SFR-	1994 UBC	1995
New	28 x 48 Double wide Fleetwood		1995
New	2 Story Duplex.		1995
New	26 8 X 68 8	1995 Marlette	1995
New	2 Story home with basement		1995
New	SFR		1995
New	SFR - Rambler style		1995
New	Reference 94-240231	RW for retaining wall.	1995
New	(On 6-28-96 this permit was found in the active files. It was then stamped finalized and approp		1995
New	STOP - PERMIT NOT PAID FOR!!!		1995
New	SFR		1995
New	SFR		1995
New	MOBILE HOME		1995
New	EXTEND TO AUGUST, 1997, PER CAROL RICHTER, PENDING RESOLUTION OF DOMESTIC DISPUTE		1995
New	SFR / GARAGE / COVERED DECK		1995
New	DUPLEX		1995
New	Two Story SFR	Non-Exempt-Rural (pre 1971 plat)	1995
New	Basic # 94-321458		1995
New	Builder Plan #1399	Basic 94-240203(B91-150)	1995
New	B91-933		1995
New	SFR		1995
New	MOBILE HOME		1995
New	2 Story log home with a basement and attached 2 car garage		1995
New	RESIDENCE/GARAGE		1995
New	SFR		1995
New	MOBILE HOME		1995
New	SFR		1995
New	new SFR	Prior Trigny application voided-#95-105148	1995
New	RESIDENCE/ GARAGE.	Plan Check Only RO27349. 8/4/94 plan check put on lot 1/26/95	1995

Accessory Dwelling Units

Index # - File Name: 1.0022 - Single Family Dwellings Data\_Snohomish County.pdf

New	RESIDENCE/GARAGE	1995
New	SFR / GARAGE	1995
New	SFR	1995
New	(On 6-28-96 this permit was found in the active files. It was then stamped finalized and approp	1995
New	basic # 94-321468 (One 6-28-96 the permit was found in the active files. It was then stamped	1995
New	Two Story SFR Exempt-Lot (SP recorded 10/20/94)	1995
New	SFR	1995
New	Work cont. on 00-102121.	1995
New	MOBILE HOME	1995
New	SFR	1995
New	Two Story SFR Approved Basic #95-103699BP	1995
New	SFR, GARAGE, COVERED PORCH	1995
New	SFR / GARAGE	1995
New	Old basic number B91-806	1995
New	Old Basic #B91-761	1995
New	Old Basic #B91-754	1995
New	SFR	1995
New	SFR	1995
New	RESIDENCE/GARAGE	1995
New	SFR / GARAGE / COVERED DECK	1995
New	RESIDENCE/GARAGE	1995
New	Two Story SFR. Permit issued on lot 2 but not built, then builder requested that these house pl	1995
New	SFR with unfinished basement. Permit issued on Lot 1, but not built, then builder requested to s	1995
New	SFR with unfinished basement	1995
New	SFR - Rambler Style	1995
New	Two Story SFR	1995
New	SFR with unfinished basement	1995
New	SFR - Rambler Style	1995
New	SFR with unfinished basement	1995
New	Tri-Level SFR	1995
New	SFR with unfinished basement	1995
New	SFR with unfinished basement	1995
New	SFRS	1995
New	Rambler Style - SFR	1995
New	(Finalized on 12/5/97 by J.Foss)	1995
New	DUPLICATE PINK FILE MADE 2-27-95. Original file still missing 2-27-95	1995
New	Reference 94-241646 GR(Formerly G 93-212	1995
New	Two Story SFR - 1994 UBC	1995
New	2 Story with a basement and a 3 car garage	1995
New	SFR & GARAGE	1995
New	SFR & GARAGE	1995
New	Rambler Style - SFR 1994 UBC	1995
New	Rambler Style - SFR 1994 UBC	1995
New	Rambler Style - SFR	1995
New	1. Cedar Crest Design	1995
New	3/14/95 - Builder came in a switched plans with new elevations. No square footage change.	1995
New	3/14/95 - Builder came in and switched plans with new elevations. No square footage changes	1995

Accessory Dwelling Units

Index # - File Name: 1.0022 - Single Family Dwellings Data\_Snohomish County.pdf

New	Old Basic B91-967	1995
New	Old Basic B91-967	1995
New	3/14/95 - Builder came in a switched plans with new elevations, square footage changed slight	1995
New	Plan Check Only. 1/23/95 Application for lot submitted.	1995
New	Plan Check Only. 1/23/95 Application submitted for lot.	1995
New	Old Basic #B91-819 Rambler Style - SFR	1995
New	Old Basic B91-966	1995
New	Old Basic #B91-970 1/12/95 Builder paid for two extra job copies.	1995
New	Old Basic #B91-747 Rambler Style - SFR	1995
New	Old Basic #B91-747 Rambler Style - SFR	1995
New	Old Basic #B91-747 Rambler Style - SFR	1995
New	Old Basic #B91-747 Rambler Style - SFR	1995
New	Old Basic #B91-747 Rambler Style - SFR	1995
New	Old Basic B91-966	1995
New	Old Basic #B91-970 1/12/95 Builder paid for two extra job copies.	1995
New	PLAN CHECK ONLY AT THIS TIME. (12/16/94) IN DATE CHANGED AS OF LOT INFORMATION SUBM	1995
New	1994 U.B.C.	1995
New	Two Story SFR 1994 UBC	1995
New	Two Story SFR 1994 UBC	1995
New	1994 UBC	1995
New	1991 UBC	1995
New	SFR - renewal o existing permit	1995
New	Affidavit on file to transfer MH permit from Dyan Cooper to Texas Alton.	1995
New	Old Basic No. 91-1041	1995
New	Rambler Style - SFR	1995
New	Rambler Style - SFR	1995
New	Two Story - SFR 1994 UBC (builder plan #SC14-94)	1995
New	MOBILE HOME	1995
New	NEW SFR-COMBO	1995
New	O lot line structure Two Story - SFR	1995
New	O lot line structure Two Story - SFR	1995
New	O lot line structure Two Story SFR	1995
New	SFR / GARAGE / COVERED DECK	1995
New	MOBILE HOME. Finaled under permit 96-109901 per Ralph Walker.	1995
New	Two Story SFR-1994 UBC	1995
New	B91-507	1995
New	Duplex	1995
New	SFR	1995
New	SFR/GARAGE/DECK/COVERED DECK	1995
New	New SFR	1995
New	Reference 95-101022 RK for site review information on SFR. Applicant has requested that SFR a	1995
New	RESIDENCE	1995
New	Approved Basic 95-107174BP (Builders Plan #1202) 1994 UBC Rambler Style - Duplex	1995
New	Approved Basic 95-107174BP (Builders Plan #1202) 1994 UBC Rambler Style - Duplex	1995
New	MOBILE HOME	1995
New	B91-254 (old basic#)	1995
New	Note: Sq. Ft. Changed Need to adjust fees	1995

Accessory Dwelling Units

Index # - File Name: 1.0022 - Single Family Dwellings Data\_Snohomish County.pdf

New	Plan Check Only - Lot application submitted 8/17/95	1995
New	Plan Check Only - Lot application submitted 8/17/95	1995
New	Approved Basic #95-108527 SFR w/unfinished basement 1994 UBC	1995
New	Approved Basic #95-108527 SFR w/unfinished basement 1994 UBC	1995
New	SFR / GARAGE / DECK	1995
New	MOBILE HOME	1995
New	SFR / GARAGE /DECK/MECH/PLMBG	1995
New	SFR, GARAGE, DECK - auto extend to 2/13/97	1995
New	Existing Basic 95-100586	1995
New	Existing Basic B91-813 (95-104770BP)	1995
New	Old Basic #B91-795	1995
New	Old Basic #B91-733 (New Basic #95100214BP)	1995
New	Old Basic #B91-733 (New Basic #95-100214BP)	1995
New	Plan Check Only - Lot application submitted 8/17/95	1995
New	Approved Basic #95-108526BP SFR w/unfinished basement 1994 UBC	1995
New	2 Story with 3 car garage	1995
New	2 Story SFR	1995
New	MOBILE HOME	1995
New	Lot 3	1995
New	MOBILE HOME	1995
New	Basic for 2 story with 3 car # 95-108207 PENDING	1995
New	SFR / GARAGE	1995
New	SFR / GARAGE	1995
New	RESIDENCE/GARAGE	1995
New	Two Story SFR - 1994 UBC	1995
New	Two Story SFR - 1994 UBC	1995
New	New SFR	1995
New	MOBILE HOME	1995
New	Structure will not fit in required footprint. New structural plans will be submitted. 6-14-95, see	1995
New	RESIDENCE/GARAGE	1995
New	B91-991	1995
New	Two Story SFR	1995
New	(On 6-28-96 this permit was found in the active files. It was then stamped finalized and approp	1995
New	Two Story SFR	1995
New	Two Story SFR	1995
New	New SFR	1995
New	Rambler Style SFR	1995
New	Rambler Style - SFR	1995
New	New SFR (7-3-96: Permit located in active files. Input final today.)	1995
New	Old Basic #B91-1052	1995
New	Two Story SFR	1995
New	Old basic B91-1052	1995
New	Old basic B91-799	1995
New	Old Basic #B91-896 SFR w/unfinished basement	1995
New	Old Basic #B91-761 SFR with unfinished basement	1995
New	Old Basic #B91-896 SFR w/unfinished basement	1995
New	Old Basic #B91-754	1995

Accessory Dwelling Units

Index # - File Name: 1.0022 - Single Family Dwellings Data\_Snohomish County.pdf

New	SFR	1995
New	Basic 95-100589	1995
New	1.)Plans approved under voided permit #270073-1991 UBC	1995
New	As-builts approved 1/17/96 by MM, routed to Alan on 1/23/96 for review. e-mailed Alan for sta	1995
New	SFR	1995
New	Property adjacent to AG-RF, property survey recorded under AF#8306235018	1995
New	SFR	1995
New	Old Basic Plan B-91-916	1995
New	Old Basic #91-915	1995
New	Old Basic Plan B-91-916	1995
New	Old Basic #B91-849	1995
New	Old Basic Plan B-91-916	1995
New	PLAN CHECK ONLY 1/19/95 Revised Plans Submitted 1/25/95 Building Application for lot subn	1995
New	Old Basic #B91-914. (Closed on 8-1-96 - owner mailed a copy of the inspection card to us.)	1995
New	Old Basic #91-915 (6-28-96: Permit was found in active files, stamped finaied and routed app	1995
New	Old Basic #B91-914	1995
New	Old Basic Plan B-91-916	1995
New	Old Basic #B91-914	1995
New	Old Basic #B91-917 (On 6-28-96 the permit was found in the active files, so was stamped final	1995
New	**Project changed from Duplex to SFR per DNS.	1995
New	(This permit was found in the active file on 6-28-96, but had been finaied on 4-6-95. It has nov	1995
New	(On 6-28-96 this permit was found in the active files. It was then stamped finaied and approp	1995
New	PLAN CHECK ONLY RO 28061	1995
New	Rambler Style - SFR Old Basic #B91-714	1995
New	(On 6-28-96 this permit was found in the active files. It was then stamped finaied and approp	1995
New	MH	1995
New	NSF CHECK	1995
New	SFR	1995
New	SFR, GARAGE, CVRD DECK Reference Grading Permit 94-140314 GR (See 5/12/95 letter JME)	1995
New	MOBILE HOME Reference Grading Permit - inspection 10/98 jme see process Reference RV Co	1995
New	Letter sent to applicant & Superior Concrete, 8/28/95. Also 106319, 106312, 106299, 106300.	1995
New	Rambler with 2 car garage	1995
New	Unifin. family room.	1995
New	See 95-105652AB for garage permit	1995
New	SFR	1995
New	SFR - Rambler Style	1995
New	Reference Mobile Home application 93-140032, Conversion file E 1601.	1995
New	Rambler Style - SFR	1995
New	1.)Existing SFR on property to be abandoned within 30 days of final on new SFR.	1995
New	SFR	1995
New	RESIDENCE/GARAGE	1995
New	SFR	1995
New	Basic #91-1067	1995
New	Old Basic #B91-864	1995
New	SFR- Rambler Style	1995
New	SFR	1995
New	Annexed to City of Lynnwood.	1995

Accessory Dwelling Units

Index # - File Name: 1.0022 - Single Family Dwellings Data\_Snohomish County.pdf

New	2 story SFR w/ basement	1995
New	@ STOP WORK POSTED 08-22-95 - McCrary @ 1. unfinished basement.	1995
New	(6-28-96: Permit was found in active permit files, stamped finalized today, and routed as usual	1995
New	Old Basic #B91-795	1995
New	SFR	1995
New	SFR / GARAGE Application updated 12-15-94	1995
New	SFR	1995
New	Duplex	1995
New	FINALLED 9/25/96 -- REFILED AND DISCOVERED ON 7/15/97 - AF	1995
New	new SFR	1995
New	SFR	1995
New	Title Elimination mobile. Unit has been on site since 1976. No site review or water required.	1995
New	(7-3-96: Permit located in active files. Input final today. Also: Notified Right-of-Way to get a l	1995
New	SFR / GARAGE / DECK	1995
New	Two Story - SFR 1994 UBC (builders plan #SC09-94) Approved Basic #95-106263BP	1995
New	Rambler Style SFR - 1994 UBC	1995
New	Approved Basic #95-107951BP 1994 UBC Builders Plan #SC14-94 Two Story SFR	1995
New	Two Story SFR - Existing Basic 95-101854	1995
New	Approved Basic #95-108850BP Two Story SFR - 1994 UBC	1995
New	Approved Basic #95-107951BP 1994 UBC Builders Plan #SC14-94 Two Story SFR	1995
New	Two Story - SFR 1994 UBC Approved Basic #95-106598BP	1995
New	Two Story SFR - 1994 UBC (builders plan #SC03-94) Approved Basic #95-106266BP	1995
New	Two Story SFR - 1994 UBC (builders plan #SC03-94) Approved Basic #95-106266BP	1995
New	Two Story SFR - 1994 UBC	1995
New	Two Story SFR - 1994 UBC (builders plan #SC03-94) Approved Basic #95-106266BP	1995
New	Two Story SFR 1994 UBC	1995
New	CONSERVANCY DESIGNATION Reference 95-100704 RK for SEPA documents	1995
New	CONSERVANCY DESIGNATION Reference 95-100705 RK for SEPA documents	1995
New	(7-3-96: Permit located in active files. Input final today.)	1995
New	(7-9-96: Received copy of finalized permit from owner, which indicates that this permit was final	1995
New	See comments.	1995
New	new SFR-see comments	1995
New	also 203207-2-001-1202 (lot 12 of Normanna Park) (7-15-96: Permit located today and stamped	1995
New	(7-15-96: Located permit and entered the final date.)	1995
New	SFR - Rambler Style	1995
New	2 Story with a 3 car	1995
New	No school, park, or 26B fees.	1995
New	SFR	1995
New	SFR with attached garage	1995
New	Two Story SFR	1995
New	Old Basic #91-938 2/7/95 - Builder applied for extra job copy of plans	1995
New	Two Story SFR - (Builders Plan 2131 Ver. of 2099 2-Story)	1995
New	new SFR	1995
New	Two Story SFR - 1994 UBC	1995
New	Woodstove removed from permit on 10/25/95	1995
New	Plan check only 4-24-95 Bldg. lot submitted dg	1995
New	Mobile Home is on property and to close to 123rd Ave NE at time of application. Owner informed	1995

Accessory Dwelling Units

Index # - File Name: 1.0022 - Single Family Dwellings Data\_Snohomish County.pdf

New	SFR	1995
New	.	1995
New	Two Story SFR	1995
New	1520 sf SFR, 430 sf Garage, single story	1995
New	Duplex	1995
New	(7-3-96: Found permit in active files. Entered final today.)	1995
New	Rambler Style - SFR 1994 UBC	1995
New	Eng. Jan V. Rohlik #27256	1995
New	SEPA Completed 1-3-96 HBK, bjm. (As of 10-4-95 This project is in violation of the permit condi	1995
New	Two Story SFR	1995
New	Two Story SFR	1995
New	Two Story SFR	1995
New	Two Story SFR	1995
New	IFR Notice #1 and #2 given to applicant	1995
New	Rambler Style - SFR	1995
New	(7-3-96: Permit located in active files. Input finalized today.)	1995
New	SFR with finished basement - Existing Basic	1995
New	SFR with finished basement - Existing Basic	1995
New	SFR	1995
New	Two Story SFR - 1994 UBC	1995
New	SFR	1995
New	Plan check only submitted 4-13-95 Lot application submitted 5/30/95	1995
New	rambler with attached garage	1995
New	Approved Basic #95-105657BP Rambler Style - SFR	1995
New	Approved Basic #95-105655BP Rambler Style - SFR	1995
New	Approved Basic #95-105654BP Rambler Style - SFR	1995
New	Plan #1084	1995
New	Rambler Style - SFR 1994 UBC Approved Basic 95-107973BP	1995
New	Rambler Style - SFR 1994 UBC Approved Basic #95-107973BP	1995
New	Rambler Style - SFR 1994 UBC Approved Basic #107982BP	1995
New	Approved Basic #95-105657BP Rambler Style - SFR	1995
New	Plan #1002	1995
New	SFR	1995
New	Plan Check Only 5/9/95 - Application for lot submitted.	1995
New	Plan check only at this time. 4/17/95 - Lot application submitted 4/19/95 - Application was orig	1995
New	Plan Check only at this time. 4/17/95 - Application for lot submitted. 4/19/95 - Application was	1995
New	Rambler with a 2 car	1995
New	Plan Check Only 5/9/95 - Application for lot submitted.	1995
New	Plan Check Only 5/9/95 - Application for lot submitted.	1995
New	New SFR	1995
New	Health District Approval 11/28/95	1995
New	new SFR	1995
New	Converting plan check only to SFR application.	1995
New	(7-3-96: Permit located in active files. Input final today.)	1995
New	2 Story SFR with attached Garage.	1995
New	SFR with attached garage	1995
New	sfr	1995



Accessory Dwelling Units

Index # - File Name: 1.0022 - Single Family Dwellings Data\_Snohomish County.pdf

New Rambler Style SFR - 1994 UBC	1995
New Two Story SFR 1994 UBC	1995
New Two Story SFR 1994 UBC	1995
New Two Story SFR 1994 UBC	1995
New Two Story SFR- 1994 UBC	1995
New Two Story SFR - 1994 UBC	1995
New Rambler Style SFR - 1994 UBC	1995
New No Duplexes as per plat.	1995
New new SFR	1995
New SFR	1995
New SFR	1995
New 2 story SFR with attached garage	1995
New Rambler Style - SFR 1994 UBC	1995
New Two Story SFR - 1994 UBC Approved Basic 95-108332BP	1995
New new SFR	1995
New new SFR	1995
New SFR	1995
New Rambler Style SFR - 1994 UBC 0 lot line structure	1995
New Two Story SFR - 1994 UBC 0 Lot Line Structure	1995
New Two Story SFR - 1994 UBC (0 lot line structure)	1995
New Two Story SFR - 1994 UBC 0 lot line structure	1995
New SFR with attached garage	1995
New Two Story SFR	1995
New	1995
New SFR	1995
New extended to 12/5/97	1995
New New SFR on Lot 1 of ZA9404071SP - original permit card sent to tax file 3/5/96; 2nd card must h	1995
New Rambler Style - SFR	1995
New Two Story SFR	1995
New Two Story SFR 6/23/95 - No new site review required as per Holly Faller. (DG & BW)	1995
New Two Story SFR - 1994 UBC	1995
New Plan check only 4/14/95-changed to RK and put on lot 5/31/95	1995
New 0 lot line structure - Plan Ck Only 1994 UBC Lot application submitted 8/1/95 Two Story - SFR	1995
New 0 lot line structure - Plan Ck Only - 1994 UBC (lot application submitted 8/1/95) Two Story SFI	1995
New 0 lot line structure - Plan Ck Only 1994 UBC (Lot application submitted 8/1/95) Two Story - SFF	1995
New Plan Check Only - March 15, 1995-Rambler Style - SFR 5/30/95 - Lot application submitted	1995
New 0 Lot line Structure Two Story SFR	1995
New 0 lot line structure Two Story SFR	1995
New 0 lot line structure Two Story SFR	1995
New Emerald Hills Estates Phase II Lot 23 (AKA as lot 65)	1995
New SFR with finished basement 1991 UBC	1995
New Two Story SFR - 1994 UBC	1995
New Approved Basic #95-108301BP Two Story SFR - 1994 UBC	1995
New Two Story SFR Existing Basic Proposed lot 5 of Ashley Lane	1995
New Existing Basic Rambler Style - SFR Proposed Lot 6 of Ashley Lane	1995
New SFRS	1995
New Vacation home - Hat Island	1995

Accessory Dwelling Units

Index # - File Name: 1.0022 - Single Family Dwellings Data\_Snohomish County.pdf

New	Tri-level with 2 car	1995
New	Approved Basic #95-109159BP Rambler Style SFR - 1994 UBC	1995
New	Rambler Style SFR - 1994 UBC	1995
New	Approved Basic #95- 108133BP Tri-Level SFR - 1994 UBC	1995
New	Plan Check Only - 9/20/95 Lot application submitted	1995
New	Plan check only at this time. - 9/20/95 Lot application submitted	1995
New	Two Story SFR - 1994 UBC	1995
New	Two Story SFR - 1994 UBC	1995
New	Two Story SFR - 1994 UBC	1995
New	SFR	1995
New	SFR on property abutting IFR land.	1995
New	Plan check only SFR. App submitted 7-12-95	1995
New	SFR	1995
New	Plan check only - Application for lot submitted 7/17/95 1994 UBC Approved Basic #95-106637	1995
New	Approved Basic #95-106639BP 1994 UBC Plan check only - Lot application submitted 7/17/95	1995
New	Approved Basic #95-106638BP 1994 UBC Plan check only - Application for Lot submitted 7/17	1995
New	Plan Ck Only - Application for lot submitted 7/17/95 Two Story SFR - 1994 UBC	1995
New	Plan Ck Only - Application for Lot submitted 7/17/95 Two Story SFR - 1994 UBC	1995
New	1165 sf unfin basement shown on original plans - removed by applicant 9-5-95	1995
New	Hat Island vacation home	1995
New	SFR	1995
New	Two Story SFR	1995
New	Plan check only - Lot application submitted 7/26/95	1995
New	Plan Ck Only - Lot application submitted 7/26/95	1995
New	Plan check only- Lot application submitted 7/26/95	1995
New	Rambler Style - SFR 1994 UBC (Builders plan name Poplar ) 1994 UBC	1995
New	Rambler Style - SFR 1994 UBC (builders plan name Ponderosa )	1995
New	Rambler Style - SFR 1994 UBC (Builders plan name Poplar )	1995
New	Rambler Style - SFR 1994 UBC (Builders plan name Ponderosa )	1995
New	Duplex	1995
New	SFR	1995
New	Emerald Hills Estates Phase I Space 1 (AKA as lot 136)	1995
New	VACATION HOUSE (REFERENCE NEW PERMIT # 95-106732)	1995
New	Space 64	1995
New	SFR	1995
New	Two Story SFR - 1994 UBC	1995
New	Rambler Style SFR - 1994 UBC	1995
New	Two Story SFR - 1994 UBC	1995
New	Rambler Style - SFR 1994 UBC	1995
New	Two Story SFR - 1994 UBC	1995
New	Two Story SFR - 1994 UBC	1995
New	Two story SFR w/unfinished basement - 1994 UBC	1995
New	Two Story SFR w/unfinished basement - 1994 UBC	1995
New	Two Story SFR w/unfinished basement - 1994 UBC	1995
New	Rambler Style - SFR 1994 UBC	1995
New	Approved Basic #95-109379BP Two Story SFR - 1994 UBC	1995
New	SFR	1995

Accessory Dwelling Units

Index # - File Name: 1.0022 - Single Family Dwellings Data\_Snohomish County.pdf

New	Ref Lot 29 Permit #96-101231	1995
New	Two Story SFR - 1994 UBC	1995
New	Rambler Style SFR - 1994 UBC	1995
New	Rambler Style SFR - 1994 UBC	1995
New	Two Story SFR- 1994 UBC	1995
New	28 x 42 1994 Marlette	1995
New	Duplex	1995
New	Mobile was removed from the site when the residence was finalized under permit #02-104171.	1995
New	Space 47	1995
New	SFR with attached garage	1995
New	1986 14 x 66 Sequoia Champion	1995
New	SFR with attached garage	1995
New	SFR	1995
New	SFR w/basement - 1994 UBC	1995
New	Duplex	1995
New	Two Story SFR - 1994 UBC	1995
New	Two Story SFR - 1994 UBC	1995
New	24 x 48 1984 Fleetwood	1995
New	Split level with a 2 car	1995
New	new SFR	1995
New	SFR with attached garage	1995
New	Daylight Rambler with 2 car	1995
New	Rambler Style SFR - 1994 UBC	1995
New	SFR w/finished basement - 1994 UBC	1995
New	Tri-Level w/finished lower floor SFR - 1994 UBC	1995
New	Two Story SFR - 1994 UBC	1995
New	Approved Basic #95-109540BP (0 lot line structure) 1994 UBC-SFR Rambler	1995
New	Approved Basic #95-109540BP (0 lot line structure) 1994 UBC-SFR Rambler	1995
New	SFR w/finished basement - 1994 UBC	1995
New	Permit #257810 has been voided by applicant. Letter on file.	1995
New	RESIDENCE/GARAGE. (On 6-28-96 this permit was found in the active files. It was then stamped)	1995
New	MOBILE HOME	1995
New	mobile home has been on property since 1988, but no permit could be found.	1995
New	SFRS	1995
New	This structure to be primary residence on property until main house is constructed. When the r	1995
New	See comments about owners name and unopened right of way. This project is being reviewed	1995
New	MOBILE HOME	1995
New	Existing 30 X40 foundation on site-Structural plan show existing foundation	1995
New	SFR / COVERED DECK	1995
New	SFR / COVERED DECK	1995
New	SFR W/Attached Accessory Apt.	1995
New	Two Story Cabin	1995
New	replacing singlewide mobile with new double wide.	1995
New	SFR	1995
New	SFR	1995
New	TD while SFR under construction No further site review required. MM. EXPIRED W/O COUNTY	1995
New	SFR	1995

Accessory Dwelling Units

Index # - File Name: 1.0022 - Single Family Dwellings Data\_Snohomish County.pdf

New	MOBILE HOME	1995
New	1) 5-10-95 Mobile Home Removal Affdt. in file	1995
New	.	1995
New	SFR GARAGE	1995
New	Plan check was done as plan check only on old app #R027878.	1995
New	Eng. Charles B. Waugh #18826 Eng. Kris P. Hamilton #16306 Eng. Jeffrey McClure #4413	1995
New	SFR w/unfinished basement & attached breezeway to garage - 1994 UBC	1995
New	Basement unfinished	1995
New	Reference Permit #263521, #257774, #263080.	1995
New	See 97-106436.	1995
New	Mobile Home	1995
New	Approved Basic #95-321561BP Option for 3rd car garage approved 7/11/95	1995
New	MOBILE HOME. EXPIRED W/O COUNTY APPROVAL TO OCCUPY OR USE. PERMIT SENT TO MICR	1995
New	Two Story SFR	1995
New	Rambler with attached garage	1995
New	1996 Golden Manor 66 x 27	1995
New	SFR / GARAGE	1995
New	2 Story with semi-finished basement Changed from electric heat to LPG 2-27-96 - plan checker	1995
New	Existing mobile home	1995
New	Replacing existing house	1995
New	10/26/95 - Owner came in and changed from forced air electric to electric heat pump.	1995
New	MOBILE HOME	1995
New	Reference 95-109821-IR for expired permit # 249597	1995
New	Detached Accessory Apartment and garage	1995
New	EXTENDED TO APRIL 1997 - Reference permits #271167 & 259554	1995
New	14 x 70 - 1974 Glenbrook MH - Rev-8/20/96	1995
New	Rambler with 2 car	1995
New	Mobile home permit for mobile home placed on property in 1979	1995
New	MOBILE HOME Reference 94-125940 GR for Grading Permit	1995
New	Rambler Style - Duplex	1995
New	SFR	1995
New	1962 mobile home/non-insignia NOTE; 4/05/95 Suspended, bill created but no \$\$\$, owner	1995
New	See comments 2/13/96.	1995
New	Plan Check Only submitted 3/6/95 under #95-101902 RP	1995
New	Two Story SFR - 1994 UBC	1995
New	8/11/95- Permit on Hold due to problem with water. CJ&NA 3-35-96-SHD has released hold or	1995
New	Crossing Permit for sewer line only D002394.	1995
New	SFR	1995
New	Foundation already dug-Septic field off site	1995
New	Mobile Home on site since 1978 per applicant - permit being obtained for title elimination purp	1995
New	Two Story SFR	1995
New	Plan Check Only - Lot application submitted 8/23/95 - reference Voided permit #95-103295, ref	1995
New	Reference permit for Grading and Retaining Wall. 95-102351 RW and 95-102351 GR	1995
New	(7-3-96: Permit located in active files. Input final today.)	1995
New	SFR replacing MH	1995
New	Mobile already on site	1995
New	New SFR	1995

Accessory Dwelling Units

Index # - File Name: 1.0022 - Single Family Dwellings Data\_Snohomish County.pdf

New	Basic #91-999	1995
New	new SFR	1995
New	2 Story with a 2 car garage	1995
New	ref previous permit #267497	1995
New	MOBILE HOME	1995
New	This is a mobile home permit to reinstate expired permit 267470. (6-mo. notice mailed 2/97)	1995
New	MOBILE HOME See garage 94-140733AB. Void letter sent 3-8-95, Application extended to 3-25	1995
New	SFR with detached garage	1995
New	new SFR Eng. Michael G. Wray #28710	1995
New	new SFR	1995
New	New SFR	1995
New	Mobile Home Guest House	1995
New	new SFR	1995
New	Two Story SFR	1995
New	(Finaled by H.Reeves.)	1995
New	new SFR	1995
New	CLOSED 5/15/98; WORK CONT. ON NEW PERMIT 98-104669.	1995
New	SFR/GARAGE/STORAGE ROOM	1995
New	MOBILE HOME - FINALLED UNDER 97-110167 IR	1995
New	MOBILE HOME - FINALLED UNDER 97-110168 IR	1995
New	2 Story house with 2 car garage	1995
New	REFERENCE INSPECTION REPORT 95-107995, VIA RALPH WALKER.	1995
New	MOBILE HOME	1995
New	Revised plans submitted to Alan Husby 10-27-97 mlo 1.)Bridge under 95-101780 BR. All SEP,	1995
New	SFR replacing main mobile home on site. Second mobile home on site as per ZA8507173.	1995
New	SFR, DECK	1995
New	Water not cleared by SHD-permit on hold/no inspections till water approved. If any questions s	1995
New	5-16-95 Applicant converted from Electric BB to Elec. Forced Air. dg	1995
New	See comments.	1995
New	Approved Basic B91-1045	1995
New	Rambler Style - SFR	1995
New	Two Story SFR	1995
New	SFR w/finished basement - 1994 UBC	1995
New	(6-28-96: Permit was found in active files, stamped finaled and routed appropriately.)	1995
New	1984 Mobil put on in 1984 without permit	1995
New	Two Story SFR	1995
New	SFR (**SEE NEW PERMIT # 97-101665 RK)	1995
New	Plans Check Only Application for lot submitted on 7/13/95.	1995
New	Changed from Plan Check Only to submitting for site review 2-21-95.	1995
New	RSP routed to SHD and site review 6/14/95 RSP approved by Ted I. 6/16/95	1995
New	SFR	1995
New	See Comments field	1995
New	Garage foundation/footing already existing	1995
New	SFR	1995
New	(7-3-96: Permit located in active bins. Input final today)	1995
New	Existing mobile home on site to become temporary dwelling ( see 95-103757TD ).	1995
New	Work cont. on new permit, 99-111664.	1995

Accessory Dwelling Units

Index # - File Name: 1.0022 - Single Family Dwellings Data\_Snohomish County.pdf

New	MOBILE HOME - expired without final; work finished under 97-109001 CM	1995
New	DUPLEX	1995
New	SFR	1995
New	2 Story Log House	1995
New	5/15/95 - Square footage changed per plans examiner, changed fees & val. in computer.	1995
New	Geotech approval for excavation prior to pouring concrete.	1995
New	Mobile Home	1995
New	Revised site plan submitted per bldg. inspt.. footing approved and in place for mobile home. RS	1995
New	Plans revised 10-10-95 Engineer was Clayton M Canfield #31466.	1995
New	2 Story with 4 car garage	1995
New	SFR/GARAGE	1995
New	Mobile Home	1995
New	MOBILE HOME	1995
New	1851 Daylite rambler no garage	1995
New	SFR - Rambler Style	1995
New	MOBILE HOME	1995
New	sfr w/ garage, deck & covered deck	1995
New	reference 273065 - storage shed	1995
New	double wide mobile	1995
New	New SFR replacing existing Cabin	1995
New	B95 104636	1995
New	SFR	1995
New	27 x 52 doublewide MH	1995
New	MOBILE HOME ***SEE NEW PERMIT #98-110736 MH *****	1995
New	2 story SFR with unfinished basement	1995
New	SFR w/ bsmt & garage	1995
New	Old Basic B91-956	1995
New	1991 28 x 56 Fleetwood	1995
New	SFR	1995
New	SFR	1995
New	SEE NEW PERMIT 98-100800 MH.	1995
New	SFR	1995
New	double wide mobile	1995
New	2 story sfr with unheated bonus/storage room	1995
New	Two Story SFR - 1994 UBC	1995
New	Two Story SFR - 1994 UBC	1995
New	Building permit for log SFR existing built without permit at time of construction	1995
New	Two Story SFR -1994 UBC	1995
New	Two Story SFR - 1994 UBC	1995
New	40 x 66 1995 Marlette with attached 2 car garage w/ second story Permanent Residence. (Refe	1995
New	RK and AB under same #	1995
New	Two Story SFR. Original plan check under R027287 was for a three story SFR but on 2/8/95, app	1995
New	Double wide mobile home	1995
New	MOBILE HOME	1995
New	Existing structure built without permits Revised foundation drawings 8-31-95 to VM	1995
New	9/25/97 - permit renewed, ok d per Rella Morris	1995
New	Mobile is replacing SFR that was destroyed by fire within same footprint. NSR	1995

Accessory Dwelling Units

Index # - File Name: 1.0022 - Single Family Dwellings Data\_Snohomish County.pdf

New	Accessory Apartment	1995
New	SFR w/finished basement 1994 UBC	1995
New	OK TO INSPECT; STOP WORK PER HEALTH DISTRICT REMOVED 1/9/97	1995
New	SFR with basement	1995
New	SFR	1995
New	SFR	1995
New	Note previous application 95-102419 MB on file. Site info is being transferred but application w	1995
New	SFR / GARAGE	1995
New	double wide mobile	1995
New	Notice #1 and #2 given to applicant. Notice 1 recorded & returned 8-7-95 (7-10-96: Permit wa	1995
New	Land Use Accessory Apt. File #95-105128AA(issued 6-26-95)	1995
New	Space # 5A (Please see Inspection Report under the same - 95-105134.) Space 95 & 87. 95-10!	1995
New	Replacing residence with double wide mobile home.	1995
New	28x63 1996 Marlette-Brookwood	1996
New	14x70 1990 Fleetwood Mobile Home	1996
New	27x60 1996 Silvercrest	1996
New	Rambler Style SFR - 1994 UBC	1996
New	Rambler Style SFR - 1994 UBC	1996
New	28 x 44 1996 Palm Harbor	1996
New	SFR	1996
New	28 x 60 1990 Sequo Champion	1996
New	SFR	1996
New	2nd Story SFR above existing garage - 816 sq. ft.	1996
New	New 2 story SFR replacing existing SFR	1996
New	Two Story SFR - 1994 UBC	1996
New	2 Story with a 2 car	1996
New	SFR	1996
New	SFR	1996
New	Two Story SFR - 1994 UBC	1996
New	1 story SFR with daylight basement and attached garage	1996
New	Rambler with a 3 car	1996
New	1996 27 x 66 Palm Harbour	1996
New	2 story SFR with attached garage	1996
New	MOBILE HOME	1996
New	SFR with attached garage	1996
New	Reference 95-106294 GR for Grading Permit.	1996
New	2 story w/ garage & covered porch	1996
New	Duplex, garage, deck, tower, 1994 ubc	1996
New	2 Story with a 3 car	1996
New	Rambler with a 2 car	1996
New	Rambler with a 2 car	1996
New	2 story w/ 3 car	1996
New	2 story SFR with attached garage	1996
New	Rambler w/2 car	1996
New	2 story w/daylight bsmt, & 2 car	1996
New	Two Story SFR	1996
New	Single wide mobile - PERMIT RENEWED 7/13/1998	1996

Accessory Dwelling Units

Index # - File Name: 1.0022 - Single Family Dwellings Data\_Snohomish County.pdf

New	28 x 66 Palm Harbor	1996
New	2 story w/3 car	1996
New	2 story w/ bsmt, 3 car garage	1996
New	Two Story SFR - 1994 UBC	1996
New	2 Story with a basement and a 3 car garage	1996
New	SFR	1996
New	2 Story with garage in basement	1996
New	2114 sq. ft. 2-story (no garage)	1996
New	SFR	1996
New	2 story SFR w/ garage	1996
New	20 x 40 1970 Elcar with 10 x 30 awning and 8 x 8 deck	1996
New	2 Story with a 3 car	1996
New	STOP WORK 7-30-96 - TI Condition of #1 permit has been violated. Silt fence is incorrectly placed	1996
New	2117 SF Rambler with attached garage - VOIDED per Contractor 1/24/97 - AF TRANSFERRED per	1996
New	Approved Basic #96-108624BP Plan #1365 SFR w/finished basement - 1994 UB	1996
New	1962 sq. ft. 2-story w/434 sq. ft attached garage	1996
New	Duplex with common recreation room at first floor	1996
New	RESIDENCE/GARAGE Reference 93-140506 MH	1996
New	2374 SF rambler with attached garage	1996
New	SFR	1996
New	SFR	1996
New	28 x 44 Fleetwood mobile home	1996
New	Approved Basic #96-105898BP Two Story SFR - 1994 UBC	1996
New	Approved Basic #95-108734BP SFR w/finished basement - 1994 UBC	1996
New	1990 sq ft. SFR w/ 230 sq. ft. attached garage	1996
New	Single Story SFR with Attached Garage (Finaled by C.Griffith on 6/9/97)	1996
New	SFR	1996
New	27 X 56 1997 Fleetwood	1996
New	existing Mobile Home - 27x56 1982 Marlette	1996
New	1996 28 x 48 Goldenwest	1996
New	1 story SFR	1996
New	Re-build Fire Damage	1996
New	1985 14 x 56 Guirdon	1996
New	MOBILE HOME	1996
New	SFR	1996
New	2 Story SFR with daylight basement and attached garage	1996
New	2 story w/2 car	1996
New	Rambler with a 2 car	1996
New	Tearing old SFR and rebuilding new SFR	1996
New	2 Story SFR with attached garage	1996
New	2 story w att garage	1996
New	Double Wide Mobile Home	1996
New	Double Wide Mobile	1996
New	rambler w/ 3 car	1996
New	1995 Marlette 26 8 x 52	1996
New	Rambler Style SFR - 1994 UBC	1996
New	SFR	1996



Accessory Dwelling Units

Index # - File Name: 1.0022 - Single Family Dwellings Data\_Snohomish County.pdf

New	2 story duplex w/ garages	1996
New	new SFR	1996
New	Tri-Level with attached Garage	1996
New	SFR Reference 96-101247 GR	1996
New	1292 sq. ft. 2-story w/726 sq., ft. garage and 208 sq. ft. covered porch/deck	1996
New	new SFR Increased tank size from 125 to 500 gallon 7-3-96	1996
New	SFR with Basement and attached Garage	1996
New	SFR w/ basement and garage	1996
New	1976 14 x 66 Corinth	1996
New	SFR	1996
New	Split level with a 2 car	1996
New	SFR	1996
New	SFR	1996
New	Mobile Home Permit for Title Elimination, MH on property since 1985	1996
New	Double-wide MH	1996
New	1989 Fleetwood	1996
New	2 story SFR	1996
New	2756 sq. ft. 2-story w/917 sq. ft. garage and 140 sq. ft. covered deck/porch	1996
New	2 story SFR with attached garage	1996
New	SFR	1996
New	3000 sf rambler, 870 sf garage, deck	1996
New	new SFR	1996
New	Two Story w/finished basement - 1994 UBC	1996
New	See 98-108802.	1996
New	Mobile Home is existing on property 24 x 52 1970 Buddy	1996
New	2 story SFR	1996
New	2-story SFR w/unfin Bsmt & Attached Garage NOTE: No wood stove installed at time of final in	1996
New	720 SF 2 story garage with living space upstairs	1996
New	1996 28x48 Waverly Crest Mobile Home replacing existing SFR	1996
New	MH for Title Elimination 28 X 76 Port Royal 1977	1996
New	new SFR	1996
New	SFR w/unfinished basement - 1994 UBC @@@@ NOTE: JULY 2, 1996 AT 1:24 P.M....APPLICAN	1996
New	Two Story SFR - 1994 UBC @@@@NOTE: ON 07-02-96 A STOP WORK WAS POST AT 1:24 P.M.	1996
New	SFR w/unfinished basement - 1994 UBC @@@@NOTE: ON 07-02-96 A STOP WORK WAS POST B'	1996
New	Double wide Mobile Home	1996
New	2 Story SFR	1996
New	Approved Basic #95-109726BP (THIS BASIC IS ONLY APPROVED FOR 2 CAR) Two Story SFR - 19'	1996
New	Approved Basic #96-103100BP Two Story SFR - 1994 UBC Reinspection fees paid 9/17/96 (jls)	1996
New	2-Story SFR w/attached Garage	1996
New	2 Stroy with a 2 1/2 car	1996
New	Two Story SFR - 1994 UBC	1996
New	Approved Basic #96-103100BP Two Story SFR - 1994 UBC	1996
New	Approved Basic #96-103100BP Two Story SFR - 1994 UBC	1996
New	SFR	1996
New	2 story w/ 2 car, covered deck	1996
New	sfr, garage, deck	1996
New	SFR	1996

Accessory Dwelling Units

Index # - File Name: 1.0022 - Single Family Dwellings Data\_Snohomish County.pdf

New	SFR with an attached garage	1996
New	new SFR	1996
New	SFR with daylight basement and attached garage	1996
New	Rambler w/ 2 car	1996
New	Detached Accessory Apt with Shop/Garage	1996
New	Double Wide Mobile Home	1996
New	SFR	1996
New	Triple Wide Mobile Home	1996
New	24x60 Skyline (1978)	1996
New	Double Wide Mobile	1996
New	Daylite Rambler with 2 car garage in basement	1996
New	66x28 (1997) Manor Marlette	1996
New	816 sq. ft. detached accessory apartment w/48 sq. ft. motorcycle garage	Land use application f 1996
New	SFR	1996
New	Duplex with Attached Garage	1996
New	2 Story with a 2 car	1996
New	Rambler with a 2 car	1996
New	Rambler Style SFR - 1994 UBC (REF EXPIRED PERMIT # 261063)	1996
New	SFR	1996
New	Double Wide Mobile Home	1996
New	1894 sq. ft 2-storey w/440 sq. ft. attached garage	1996
New	SFR	1996
New	2 Story SFR w/ garage & covered porch	1996
New	SFR	1996
New	Two Story SFR - 1994 UBC	1996
New	SFR	1996
New	SFR-Rambler-1994 UBC	1996
New	SFR w/finished basement - 1994 UBC	1996
New	Peters contact-Ripley	1996
New	1996 40 x 66 Goldenwest	1996
New	1990 26 x 52 Guirdon	1996
New	24x64, (1972) Vilaw	1996
New	2 story sfr w/ covered deck	1996
New	26x40 (1996) Valley (Used as Guest House)	1996
New	Rambler w/covered porch	1996
New	Single Story SFR with Attached Garage	1996
New	2 Story with no garage	1996
New	40 x 48 Valley Mansion Mobile Home	1996
New	Two Story w/unfinished basement SFR - 1994 UBC	1996
New	24 x 40 - 1980 Four Seasons Mobile home	1996
New	2 Story no garage	1996
New	Split level w/2 car	1996
New	Split level with a 2 car	1996
New	Rambler w/partial bsmt & 2 car	1996
New	2 Story SFR with attached garage	1996
New	Triple Wide Mobile Home	1996
New	1996 28 x 66 Ardmore	1996

Accessory Dwelling Units

Index # - File Name: 1.0022 - Single Family Dwellings Data\_Snohomish County.pdf

New	2 story w/ bsmt, 3 car gar, deck	1996
New	28x52, 1997 Goldenwest	1996
New	2-Story SFR w/attached garage	1996
New	Approved Basic #96-109189BP Plan #7084 Two Story SFR - 1994 UBC	1996
New	SFR-Rambler- 1994UBC	1996
New	SFR- Rambler-1994 UBC	1996
New	Single Story SFR with attached Garage	1996
New	SFR- Rambler- 1994 UBC	1996
New	SFR-Rambler- 1994 UBC	1996
New	mobile home	1996
New	new MH	1996
New	new SFR	1996
New	new SFR	1996
New	SFR Rambler	1996
New	SFR w/attached Garage.	1996
New	Replacing MH with new two story SFR	1996
New	SFR NOTE: File location - Steve Holt s Office 1/21/97 jc	1996
New	42 X 66 Golden West 1997	1996
New	Upstairs (1440 sq. ft.) of existing shop/storage bldg. to be converted to Living Space	1996
New	MH in River & Forest Tract	1996
New	Rambler with attached garage	1996
New	Rambler w/2 car	1996
New	Rambler w/2 car	1996
New	Approved Basic #95-110737BP Rambler Style SFR - 1994 UBC	1996
New	Approved Basic #95-110737BP Rambler Style SFR - 1994 UBC	1996
New	2211-sf Rambler with Attached Garage	1996
New	MH, has been on site since 1979	1996
New	Singlewide MH 14 x66 - Title Elimination, MH on lot since 1989	1996
New	27x56 Glenwood 1996	1996
New	62 x 27 Marlette 1996	1996
New	Single Story SFR with attached Garage	1996
New	28 x 40 1986 Factory Home - Mobile Home	1996
New	2-Story SFR w/unfin. Bsmt & Attached Garage	1996
New	1996 double-wide Palm Harbour MH -	1996
New	Split leval with a 2 car and unfinished basement	1996
New	2 Story with a 3 car	1996
New	FINALED PERMIT SIGNED BY RALPH WALKER ON 2/3/97 WAS OBTAINED FROM TAX FILE ON 5/1	1996
New	new SFR	1996
New	24 x 56 Goldenwest Mobile Homes	1996
New	SFR (Finaled on 12/5/97 by C.Koch)	1996
New	Split leval with unfinished basement and 2 car garage	1996
New	VIOLATION: supposedly on lot 79 but may be on 78 & 80 also, CT response tracking for all lots u	1996
New	VIOLATION: supposedly on lot 79 but may be on 78 & 80 also, CT response tracking for all lots u	1996
New	Double Wide Mobile	1996
New	2-story SFR w/ attached garage	1996
New	NON-OCCUPANCY NOTICE POSTED 4/12/00 BY CECIL KOCH.; acquired new permits 5/5/00. IN C	1996
New	12 x 24 unit, no kitchen facilities, for use as rec room.	1996

Accessory Dwelling Units

Index # - File Name: 1.0022 - Single Family Dwellings Data\_Snohomish County.pdf

New	SFR	1996
New	1497 SF SFR with attached garage	1996
New	1705 SF SFR with attached garage	1996
New	new SFR	1996
New	28 x 66 1996 Palm Harbor mobile home	1996
New	rambler w/basement & 2 car	1996
New	26 8 x 66 1996 Marlette	1996
New	1344 SF Rambler	1996
New	SFR	1996
New	Existing foundation on property. Mobile home removal affdt. given to applicant. Right to farn	1996
New	1996 Spring Manor 28 x56 Mobile Home	1996
New	41 x 66 1996 Golden West	1996
New	SFR	1996
New	Double Wide-replacment of existing mobile	1996
New	2226 Sq. ft. 2-story SFR (no garage)	1996
New	Rambler with a 2 car *Finaled by C.Koch.	1996
New	new SFR ***** 2/25/97, 3-gas pipes and 1 lpg-250gal, tank deleted from permit at	1996
New	2 Story with 1 car garage	1996
New	28x48 (1996) Skyline	1996
New	Double Wide MH	1996
New	SFR	1996
New	SFR	1996
New	SFR	1996
New	14x56, 1977 Ridgewood	1996
New	Daylight Bsmt SFR w/attached Garage	1996
New	1996 - 26.5 x 56 Liberty Mobile Home	1996
New	40 x 68 VMHI Mansion. EXPIRED W/O COUNTY APPROVAL TO OCCUPY OR USE. PERMIT SENT T	1996
New	new SFR	1996
New	Triple Wide Mobile	1996
New	1200 SF SFR with attached garage	1996
New	SFR	1996
New	New SFR Rambler Convert to LPG from Electric Heat	1996
New	28 x 36 MH	1996
New	1308-sf Rambler w/attached garage.	1996
New	Approved Basic #96-104979BP Rambler Style SFR - 1994 UBC	1996
New	1996 Fleetwood Waverly Crest	1996
New	2-Story SFR w/attached Garage	1996
New	1785-sf Rambler w/attached garage	1996
New	Single story w/bsmt & 2 car	1996
New	2-Story SFR w/attached Garage	1996
New	SFR / GARAGE / COVERED DECK	1996
New	Rambler with a 3 car w/bonus room	1996
New	Rambler Style SFR - 1994 UBC	1996
New	Rambler w/ basement & att garage	1996
New	Split level SFR with attached garage	1996
New	Approved Basic #96-105824BP Rambler Style SFR - 1994 UBC	1996
New	new SFR	1996

Accessory Dwelling Units

Index # - File Name: 1.0022 - Single Family Dwellings Data\_Snohomish County.pdf

New	MOBILE HOME	1996
New	Rambler with a loft and no garage	1996
New	Rambler with a 3 car garage	1996
New	SFR Garage with SFR on 2nd/ Floor	1996
New	SFR	1996
New	Triple Wide MH	1996
New	SFR w/ bsmt & att. garage	1996
New	Daylight Rambler with a 2 car	1996
New	56x12 (1974) Frontier LS 5533	1996
New	2-Story SFR	1996
New	836 SF SFR	1996
New	double wide mobile home	1996
New	Convert 2nd story of storage bldg to residence (per applicant & application copy this permit wa	1996
New	2228 SFR with attached garage	1996
New	Double Wide 28 x 66 MH	1996
New	1996 Marlette 40 X 66 Mobile Home	1996
New	28 x 60 1994 Fleetwood	1996
New	1200 SF rambler 8-5-96 Applicant is changing plans to a detached carport..Carport now on sep	1996
New	Rambler Style SFR - 1994 UBC	1996
New	single wide mobile	1996
New	SFR	1996
New	1996 Guerdon	1996
New	24 x 44 1996 Liberty Mobile Home	1996
New	1930 sq. ft. rambler w/780 sq. ft. attached garage	1996
New	15 X 50 4-Seasons Mobile Home-1994	1996
New	SFR	1996
New	Finald by C.Koch. 24 x 48 Westwood by Silvercrest Mobile Home.	1996
New	44 x 27 MH	1996
New	2 story SFR with attached garage	1996
New	Rambler with attached garage	1996
New	SFR with attached garage	1996
New	2 story w/ bsmt, attached garage, cvrd porch	1996
New	Approved Basic #96-103764BP Two Story SFR - 1994 UBC	1996
New	Double Wide Mobile	1996
New	48x28 1995 Skyline Cedar Cove MH	1996
New	2 Story with an attached carport and garage	1996
New	1990 Liberty 52x28	1996
New	1184 SF SFR with attached garage	1996
New	SFR	1996
New	SFR	1996
New	Single wide Mobile Home	1996
New	new SFR (0 lot line structure)	1996
New	SFR	1996
New	SFR	1996
New	Approved Basic #96-103463BP Rambler Style SFR - 1994 UBC	1996
New	Approved Basic #96 104557BP Rambler Style SFR - 1994 UBC	1996
New	Two Story SFR with attached Garage	1996

Accessory Dwelling Units

Index # - File Name: 1.0022 - Single Family Dwellings Data\_Snohomish County.pdf

New	Rambler Style SFR - 1994 UBC	1996
New	Approved Basic #95- 108133BP Tri-Level SFR - 1994 UBC	1996
New	Approved Basic #95-108812BP Two Story SFR - 1994 UBC	1996
New	Approved Basic #95- 108133BP Tri-Level SFR - 1994 UBC	1996
New	SFR w/finished basement - 1994 UBC	1996
New	Two Story SFR - 1994 UBC	1996
New	Tri-Level SFR w/finished lower floor - 1994 UBC	1996
New	Tri-Level w/finished lower floor - 1994 UBC	1996
New	1656 SF SFR with attached garage	1996
New	SFR w/finished basement - 1994 UBC	1996
New	SFR w/finished basement - 1994 UBC	1996
New	Approved Basic #96-104979BP Rambler Style SFR - 1994 UBC	1996
New	Approved Basic #96-104979BP Rambler Style SFR - 1994 UBC	1996
New	FINALLED 2/27/97; ENTERED IN AMANDA 7/22/97 - AF Approved Basic #96-104979BP **7/7/	1996
New	Rambler with a 2 car	1996
New	Approved Basic #96-102270BP Two Story SFR - 1994 UBC	1996
New	Approved Basic #95-109726BP (THIS BASIC IS ONLY APPROVED FOR 2 CAR) Two Story SFR - 19	1996
New	Approved Basic #95- 108133BP Tri-Level SFR - 1994 UBC	1996
New	Approved Basic #95- 108133BP Tri-Level SFR - 1994 UBC	1996
New	Approved Basic #96-102270BP Two Story SFR - 1994 UBC	1996
New	Approved Basic #95-109726BP (THIS BASIC IS ONLY APPROVED FOR 2 CAR) Two Story SFR - 19	1996
New	Approved Basic #95-108812BP Two Story SFR - 1994 UBC	1996
New	Approved Basic #96-102270BP Two Story SFR - 1994 UBC	1996
New	Approved Basic #95- 108133BP Tri-Level SFR - 1994 UBC	1996
New	Approved Basic #96-102270BP Two Story SFR - 1994 UBC	1996
New	Approved Basic #95- 108133BP Tri-Level SFR - 1994 UBC	1996
New	2-story SFR w/attached Dbl Garage.	1996
New	Approved Basic #96-100746BP Rambler Style SFR - 1994 UBC	1996
New	Approved Basic #96-102270BP Two Story SFR - 1994 UBC	1996
New	Approved Basic #95-109726BP (THIS BASIC IS ONLY APPROVED FOR 2 CAR) Two Story SFR - 19	1996
New	Approved Basic #95- 108133BP Tri-Level SFR - 1994 UBC	1996
New	Approved Basic #95-108812BP Two Story SFR - 1994 UBC	1996
New	Approved Basic #95- 108133BP Tri-Level SFR - 1994 UBC	1996
New	Approved Basic #95-109726BP (THIS BASIC IS ONLY APPROVED FOR 2 CAR) Two Story SFR - 19	1996
New	Approved Basic #95-108812BP Two Story SFR - 1994 UBC	1996
New	Approved Basic #96-100746BP Rambler Style SFR - 1994 UBC	1996
New	Approved Basic #96-102270BP Two Story SFR - 1994 UBC	1996
New	Approved Basic #96-102270BP Two Story SFR - 1994 UBC	1996
New	Approved Basic #95-108812BP Two Story SFR - 1994 UBC	1996
New	Approved Basic #95- 108133BP Tri-Level SFR - 1994 UBC	1996
New	Approved Basic #95-109726BP (THIS BASIC IS ONLY APPROVED FOR 2 CAR) Two Story SFR - 19	1996
New	Approved Basic #96-102270BP Two Story SFR - 1994 UBC	1996
New	Approved Basic #95- 108133BP Tri-Level SFR - 1994 UBC	1996
New	Approved Basic #95-108812BP Two Story SFR - 1994 UBC	1996
New	Approved Basic #96-102270BP Two Story SFR - 1994 UBC	1996
New	2 story SFR	1996
New	new SFR	1996

Accessory Dwelling Units

Index # - File Name: 1.0022 - Single Family Dwellings Data\_Snohomish County.pdf

New	2 story sfr, garage, covered porch, deck	1996
New	2-Story SFR w/attached Garage	1996
New	2-Story Duplex w/attached garages	1996
New	1996 52 x 27 Fleetwood	1996
New	Rambler with a 3 car	1996
New	1704 sq. ft. rambler w/690 sq/ ft. attached garage	1996
New	2 story SFR with attached garage	1996
New	1656 sq. ft. rambler w/520 sq. ft. garage	1996
New	Split Level SFR with attached garage	1996
New	1704 sq ft SFR w/484 sq. ft. attached garage	1996
New	1344 SF Split level entry SFR	1996
New	Duplex - Single Story	1996
New	2 Story cabin on Hat Island	1996
New	2 Story with a 3 car	1996
New	SFR	1996
New	Reference: Expired Permit # 224401 SFR & attached Carport	1996
New	SFR	1996
New	2 Story with a 2 car	1996
New	Mobile Home	1996
New	SFR w/ bsmt, garage, & deck	1996
New	SFR with attached garage	1996
New	28 x 66 MH	1996
New	2 story SFR w/ 2 car garage- 1994 UBC	1996
New	1993 14 x 52 Liberty	1996
New	Ref File # 97-100476 GR (See Pink File ) 2-21-97. DNS. Approved Basic #96-101623BP ***NOT	1996
New	28x66 (1996) Golden West	1996
New	28 X 56 1995 Golden West MH	1996
New	2 Story with a 3 car garage	1996
New	Approved Basic #96-106191BP SFR w/finished basement - 1994 UBC	1996
New	SFR w/finished basement - 1994 UBC	1996
New	SFR w/finished basement - 1994 UBC	1996
New	Two Story SFR - 1994 UBC	1996
New	new SFR	1996
New	new SFR	1996
New	Approved Basic #96-105319BP Two Story SFR - 1994 UBC	1996
New	Approved Basic #96-106191BP SFR w/finished basement - 1994 UBC	1996
New	Approved Basic #96-106191BP SFR w/finished basement - 1994 UBC	1996
New	2 Story with a 2 car garage	1996
New	2 Story SFR/attached garage.	1996
New	2.Story with a 3 car garage	1996
New	Approved Basic #96-101352	1996
New	Approved Basic #96-101352	1996
New	Two Story SFR - 1994 UBC	1996
New	Two Story SFR - 1994 UBC	1996
New	2 Story with a 3 car	1996
New	SFR w/unfinished basement - 1994 UBC	1996
New	Two Story SFR - 1994 UBC	1996

Accessory Dwelling Units

Index # - File Name: 1.0022 - Single Family Dwellings Data\_Snohomish County.pdf

New	2 Story with a 3 car	1996
New	SFR	1996
New	2 Story with a 3 car	1996
New	Split level 1 with a 3 car	1996
New	2 Story with a 3 car	1996
New	Approved Basic #95-110755BP (2/3 car option approved) Two Story SFR - 1994 UBC	1996
New	2 Story no garage (Finaled on 12/5/97 by R.Walker)	1996
New	Approved Basic #95-109379BP Plan 1936 Two Story SFR - 1994 UBC	1996
New	2 story SFR-1994 UBC	1996
New	Approved Basic #95-109379BP Two Story SFR - 1994 UBC	1996
New	2-Story SFR w/attached Garage	1996
New	Two Story SFR - 1994 UBC	1996
New	Approved Basic #95-110755BP Two Story SFR - 1994 UBC	1996
New	Two Story SFR - 1994 UBC	1996
New	Two Story SFR - 1994 UBC	1996
New	Two Story SFR - 1994 UBC	1996
New	Two Story SFR - 1994 UBC	1996
New	Rambler Style SFR - 1994 UBC	1996
New	2-Story SFR, w/attached Garage	1996
New	Split level with a 2 car	1996
New	Split level with a 2 car	1996
New	new MH	1996
New	2 story w/ 2 car	1996
New	Flood Hazard permit issued under #95-107278	1996
New	2-Story w/Attached garage - 1994 UBC	1996
New	Approved Basic #96-105548BP SFR w/finished basement - 1994 UBC	1996
New	Approved Basic #96-102448BP Rambler Style SFR - 1994 UBC	1996
New	2 story SFR w/ 2 car garage	1996
New	SFR w/ Att. garage	1996
New	SFR	1996
New	2-story w/attached Garage	1996
New	Rambler Style SFR - 1994 UBC	1996
New	2 story SFR w/ 2 car garage- 1994 UBC	1996
New	Rambler Style SFR - 1994 UBC	1996
New	2 Story SFR	1996
New	2 story sfr, garage, covered deck	1996
New	SFR (Permit finaled by C.Koch)	1996
New	new SFR	1996
New	27 x 52 1996-Fleetwood Mobile Home	1996
New	Rambler with a 2 car	1996
New	2 story SFR with attached garage	1996
New	1581 SF SFR with attached garage	1996
New	2- Story SFR with attached garage	1996
New	SFR	1996
New	4th Ave. West Estates MH Park - Space 10 (aka McLaughlin Manor MH Park) 28x48 (1996) Mar	1996
New	Rambler with a 3 car	1996
New	2 Story house	1996



Accessory Dwelling Units

Index # - File Name: 1.0022 - Single Family Dwellings Data\_Snohomish County.pdf

New	2 Story SFR w/ covr d porch			1996
New	Rambler Style SFR w/attached Garage			1996
New	New SFR w/ garage			1996
New	2 Story duplex with 1 car garages each side			1996
New	SFR			1996
New	Approved Basic 96-101522-001BP	2 Story with a 3 car	Plan 6220 W/Bonus	1996
New	Approved Basic 96-101522-001BP	2 Story with a 3 car	Plan 6220 W/Bonus	1996
New	Approved Basic #96-101520-002B	2 Story with a 3 car	Plan # 6230 A W/ Bonus	1996
New	Approved Basic #96-101520-003BP	2 Story with a 3 car	Plan # 6230 B W/ Bonus	1996
New	Approved Basic 96-101522-001BP	2 Story with a 3 car	Plan 6220 W/Bonus	1996
New	Approved Basic 96-101522-001BP	2 Story with a 3 car	Plan 6220 W/Bonus	1996
New	Approved Basic #96-101526-002BP	2 Story with a 3 car	Plan 6210 W/ Bonus	1996
New	Approved Basic 96-101522-001BP	2 Story with a 3 car	Plan 6220 W/Bonus	1996
New	Approved Basic #96-101520-003BP	2 Story with a 3 car	Plan # 6230 B W/ Bonus	1996
New	Approved Basic 96-101522-001BP	2 Story with a 3 car	Plan 6220 W/Bonus	1996
New	Approved Basic #96-101520-003BP	2 Story with a 3 car	Plan # 6230 B W/ Bonus	1996
New	Approved Basic 96-101522-001BP	2 Story with a 3 car	Plan 6220 W/Bonus	1996
New	Approved Basic #96-101526-001BP	2 Story with a 3 car	Plan 6210 W/O Bonus	1996
New	Approved Basic #96-102270BP	Two Story SFR - 1994 UBC		1996
New	2 story SFR			1996
New	new SFR 4-5-96 Spoke to Jane Erickson re:Forest Practices permit. She stated that it is OK to is			1996
New	Split levelw/2car			1996
New	28 x 60 , 1994 Silvercrest SPACE 25			1996
New	Approved Basic #95-106587BP	0 LOT LINE STRUCTURE	Two Story SFR (1994 UBC)	1996
New	SFR			1996
New	single story sfr w/ garage, covered deck, deck, and bonus room			1996
New	Approved Basic #95-106583BP	0 LOT LINE STRUCTURE	Two Story SFR (1994 UBC)	1996
New	Approved Basic #95-106583BP	0 LOT LINE STRUCTURE	Two Story SFR (1994 UBC)	1996
New	Approved Basic #96-101922BP	0 LOT LINE STRUCTURE	Two Story SFR - 1994 UBC	1996
New	Approved Basic #96-101921BP	0 LOT LINE STRUCTURE	Two Story SFR - 1994 UBC	1996
New	Approved Basic #95-106583BP	0 LOT LINE STRUCTURE	Two Story SFR (1994 UBC)	1996
New	Approved Basic #95-106583BP	0 LOT LINE STRUCTURE	Two Story SFR (1994 UBC)	1996
New	Approved Basic #95-106585BP	0 LOT LINE STRUCTURE	Two Story - SFR (1994 UBC)	1996
New	Approved Basic #96-101921BP	0 LOT LINE STRUCTURE	Two Story SFR - 1994 UBC	1996
New	Approved Basic #95-106583BP	0 LOT LINE STRUCTURE	Two Story SFR (1994 UBC)	1996
New	Approved Basic #96-101920BP	0 LOT LINE STRUCTURE	Two Story SFR - 1994 UBC	1996
New	Approved Basic #95-106585BP	0 LOT LINE STRUCTURE	Two Story - SFR (1994 UBC)	1996
New	Two Story SFR - 1994 UBC	0 Lot Line Structure - Willow	FINALED BY J.GABLE (Rec d for in	1996
New	Two Story SFR - 1994 UBC	0 Lot line Structure	Walr	1996
New	Two Story SFR - 1994 UBC	(0 lot line structure) - Spruce	FINALED BY TRACY JUSTICE 2-4-97 (Re	1996
New	Approved Basic #95-106587BP	0 LOT LINE STRUCTURE	Two Story SFR (1994 UBC)	1996
New	Approved Basic #95-106583BP	0 LOT LINE STRUCTURE	Two Story SFR (1994 UBC)	1996
New	Approved Basic #95-106583BP	0 LOT LINE STRUCTURE	Two Story SFR (1994 UBC)	1996
New	Approved Basic #96-101920BP	0 LOT LINE STRUCTURE	Two Story SFR - 1994 UBC	1996
New	Approved Basic #95-106587BP	0 LOT LINE STRUCTURE	Two Story SFR (1994 UBC)	1996
New	Approved Basic #95-106583BP	0 LOT LINE STRUCTURE	Two Story SFR (1994 UBC)	1996
New	Approved Basic #95-106583BP	0 LOT LINE STRUCTURE	Two Story SFR (1994 UBC)	1996

Accessory Dwelling Units

Index # - File Name: 1.0022 - Single Family Dwellings Data\_Snohomish County.pdf

New	Approved Basic #95-106587BP	0 LOT LINE STRUCTURE	Two Story SFR	(1994 UBC)	1996
New	Approved Basic #96-101920BP	O LOT LINE STRUCTURE	Two Story SFR	- 1994 UBC	1996
New	Approved Basic #95-106583BP	0 LOT LINE STRUCTURE	Two Story SFR	(1994 UBC)	1996
New	Approved Basic #95-106583BP	0 LOT LINE STRUCTURE	Two Story SFR	(1994 UBC)	1996
New	( Inspector sign off sent to Tax Account File 4/14/97 by Kim Carlson.)	Approved Basic #95-1065			1996
New	Approved Basic #95-106586BP - 0 lot line structure (Builders Plan Name (Walnut)	Two Story SF			1996
New	Approved Basic #96-101922BP	O LOT LINE STRUCTURE	Two Story SFR	- 1994 UBC	1996
New	Approved Basic #95-106586BP - 0 lot line structure (Builders Plan Name (Walnut)	Two Story SF			1996
New	Approved Basic #96-101921BP	O LOT LINE STRUCTURE	Two Story SFR	- 1994 UBC	1996
New	Approved Basic #95-106587BP - 0 lot line structure (Builders Plan - (Cypress)	Two Story SFR			1996
New	Two Story SFR - 1994 UBC	(0 lot line structure) - OAK			1996
New	Approved Basic #95-106586BP - 0 lot line structure (Builders Plan Name (Walnut)	Two Story SF			1996
New	SFR Rambler w/ 3 car garage				1996
New	1966 sq. ft. rambler w/624 sq. ft. attached garage				1996
New	2 Story with a 3 car				1996
New	SFR				1996
New	2 story SFR with attached garage				1996
New	Originally submitted as plan check only - lot submitted 5-21-96				1996
New	Originally plan check only - lot submitted 5-21-96				1996
New	3694 sq. ft. 2-story w/966 sq.ft/ garage and 240 sq. ft. covered deck/porch				1996
New	SFR				1996
New	3204 sq. ft 2-storey SFR w/750 sq. ft. covered deck and porch (see comments)	Changed from			1996
New	SFR- Rambler- 1994 UBC				1996
New	SFR w/unfinished lower floor - 1994 UBC				1996
New	SFR w/unfinished lower floor - 1994 UBC				1996
New	Bsmt Rambler w/attached Gar.				1996
New	SFR				1996
New	Rambler w/unfin bsmt & 3 car				1996
New	SFR				1996
New	2 story w/ 3 car				1996
New	. 2-story w/ unfinished basement				1996
New	2 Story SFR with 3 car garage				1996
New	Approved Basic #95-110037BP	Two Story SFR	- 1994 UBC		1996
New	Two Story SFR	- 1994 UBC			1996
New	Rambler Style SFR	- 1994 UBC			1996
New	Two Story SFR	- 1994 UBC			1996
New	Rambler Style SFR	- 1994 UBC			1996
New	SFR				1996
New	2 Story with a 3 car				1996
New	2 story w 2 car				1996
New	2 Story with a 2 car				1996
New	2-Story SFR w/attached Garage				1996
New	2 Story SFR with Attached garage				1996
New	Tri Level with a 2 car				1996
New	Rambler w/2 car				1996
New	2 story with a 3 car				1996
New	SFR w/finished basement - 1994 UBC				1996

Accessory Dwelling Units

Index # - File Name: 1.0022 - Single Family Dwellings Data\_Snohomish County.pdf

New	2 story sfr w/ attached garage		1996
New	SFR- Rambler-1994 UBC		1996
New	2001 sq. ft. 2-story w/420 sq. ft. garage and 72 sq. ft. covered deck/porch		1996
New	new SFR		1996
New	2 storyw/3 car		1996
New	Approved Basic #96-107059BP	Plan #2084, (Elv. E - 2 car only) Two Story SFR - 1994 UBC	1996
New	Two Story SFR - 1994 UBC		1996
New	Two Story SFR - 1994 UBC		1996
New	Two Story SFR - 1994 UBC		1996
New	Two Story SFR - 1994 UBC		1996
New	2 story w/2 car		1996
New	Approved Basic #96-100410BP	Rambler Style SFR - 1994 UBC	1996
New	Approved Basic #96-102793BP	SFR w/finished basement - 1994 UBC	1996
New	Approved Basic #96-109525BP	Plan #LC969 Two Story SFR - 1994 UBC	1996
New	Approved Basic #96-103761BP	Two Story SFR - 1994 UBC	1996
New	Two Story SFR - 1994 UBC		1996
New	Two Story SFR - 1994 UBC		1996
New	Approved Basic #96-103761BP	Two Story SFR - 1994 UBC	1996
New	Two Story SFR - 1994 UBC		1996
New	2 Story with a 3 car		1996
New	2 story SFR w/ 2 car garage		1996
New	2 Story with a 3 car		1996
New	Rambler with a 2 car		1996
New	Rambler Style SFR - 1994 UBC		1996
New	2 story w/attached garage		1996
New	1161SF SFR with attached garage		1996
New	1092 SF SFR with attached garage		1996
New	Rambler Style SFR - 1994 UBC		1996
New	Rambler Style SFR - 1994 UBC		1996
New	Approved Basic #96-100410BP	Rambler Style SFR - 1994 UBC	1996
New	SFR w/unfinished basement - 1994 UBC		1996
New	SFR w/unfinished basement - 1994 UBC		1996
New	SFR w/unfinished basement - 1994 UBC		1996
New	SFR w/unfinished basement - 1994 UBC		1996
New	Rambler Style SFR - 1994 UBC		1996
New	Rambler Style SFR - 1994 UBC		1996
New	Approved Basic #96-105065BP	Rambler Style SFR -1994 UBC	1996
New	SFR Rambler w/ garage		1996
New	Approved Basic #96-100406BP	Rambler Style SFR - 1994 UBC	1996
New	Two Story SFR - 1994 UBC		1996
New	Rambler with a 2 car		1996
New	Mobile Home		1996
New	2 story SFR with attached garage		1996
New	Approved Basic #96-102793BP	SFR w/ finished or unfinished basement - 1994 UBC	1996
New	Approved Basic #96-109525BP	Plan #LC969 Two Story SFR - 1994 UBC	1996
New	Approved Basic #96-102793BP	SFR w/finished basement - 1994 UBC	1996
New	Approved Basic #96-102781BP	Rambler Style SFR - 1994 UBC	1996

Accessory Dwelling Units

Index # - File Name: 1.0022 - Single Family Dwellings Data\_Snohomish County.pdf

New	Approved Basic #96-102793BP	SFR w/finished basement - 1994 UBC	1996
New	Approved Basic #96-102786BP	Rambler Style SFR - 1994 UBC	1996
New	Approved Basic #96-102793BP	SFR w/finished basement - 1994 UBC	1996
New	Approved Basic #96-102781BP	Rambler Style SFR - 1994 UBC	1996
New	Approved Basic #96-102781BP	Rambler Style SFR - 1994 UBC	1996
New	Approved Basic #96-102781BP	Rambler Style SFR - 1994 UBC	1996
New	Approved Basic #96-103436BP	Rambler Style SFR - 1994 UBC	1996
New	Approved Basic #96-109525BP	Plan #LC969 Two Story SFR - 1994 UBC	1996
New	Two Story with unfinished basement - 1994 UBC		1996
New	new duplex		1996
New	2 Story duplex		1996
New	DUPLEX		1996
New	Rambler with a daylite unfinished basement & 2 car		1996
New	2 story SFR with attached garage		1996
New	Tri-level SFR - 1994 UBC		1996
New	8-13-96 Applicant converted zero clearance gas to wood stove, adjusted fees....dg		1996
New	1472 SF SFR with attached garage		1996
New	SFR		1996
New	Approved Basic #96-102793BP	SFR w/finished basement - 1994 UBC	1996
New	Approved Basic #96-102778BP	Rambler Style SFR - 1994 UBC	1996
New	Approved Basic #96-102778BP	Rambler Style SFR - 1994 UBC	1996
New	Approved Basic #96-103436BP	Rambler Style SFR - 1994 UBC	1996
New	Approved Basic #95-110380BP	SFR w/finished or unfinished basement - 1994 UBC	1996
New	Approved Basic #96-102793BP	SFR w/finished basement - 1994 UBC	1996
New	Approved Basic #96-109525BP	Plan #LC969 Two Story SFR - 1994 UBC	1996
New	New SFR Rambler w/attached garage		1996
New	new SFR		1996
New	2 story SFR with attached garage		1996
New	SFR- Rambler- 1994 UBC		1996
New	Approved Basic #96-102793BP	SFR w/finished basement - 1994 UBC	1996
New	Approved Basic #96-109525BP	Plan #LC969 Two Story SFR - 1994 UBC	1996
New	Approved Basic #96-102793BP	SFR w/finished basement - 1994 UBC	1996
New	Approved Basic #96-102793BP	SFR w/finished basement - 1994 UBC	1996
New	Approved Basic #96-102786BP	Rambler Style SFR - 1994 UBC	1996
New	Approved Basic #96-102786BP	Rambler Style SFR - 1994 UBC	1996
New	Approved Basic #96-103436BP	Rambler Style SFR - 1994 UBC	1996
New	Approved Basic #96-102786BP	Rambler Style SFR - 1994 UBC	1996
New	2 story SFR		1996
New	SFR		1996
New	SFR	4-5-96 Delete garage from application per Mike Coombs and adjust fees.....dg (Garage)	1996
New	2865 sq. ft. rambler w/880 sq. ft. garage		1996
New	Approved Basic #96-107423BP	Plan #1002A Two Story SFR - 1994 UBC	1996
New	Approved Basic #95-108215BP	(Elevation A&B approved) Two Story SFR - 1994 UBC	1996
New	Approved Basic #96-107423BP	Plan #1002A Two Story SFR - 1994 UBC	1996
New	Approved Basic #96-107638BP	Option Approved for Elevation B Two Story SFR - 1994 UBC	1996
New	Approved Basic #96-107638BP	Option Approved for Elevation B Two Story SFR - 1994 UBC	1996
New	Approved Basic #95-108215BP	(Elevation A,B,C approved) Two Story SFR - 1994 UBC	1996

Accessory Dwelling Units

Index # - File Name: 1.0022 - Single Family Dwellings Data\_Snohomish County.pdf

New	Approved Basic #96-107638BP	Option Approved for Elevation B	Two Story SFR - 1994 U	1996
New	Approved Basic #96-107638BP		Two Story SFR - 1994 UBC	1996
New	Approved Basic #95-108215BP	(Elevation A&B approved)	Two Story SFR - 1994 UBC	1996
New	Two Story SFR - 1994 UBC			1996
New	Approved Basic #95-108808BP		Two Story SFR - 1994 UBC	1996
New	Approved Basic #95-108215BP	(Elevation A&B approved)	Two Story SFR - 1994 UBC	1996
New	Two Story SFR - 1994 UBC			1996
New	Approved Basic #95-108708BP		Two Story SFR - 1994 UBC	1996
New	Two Story SFR - 1994 UBC			1996
New	Approved Basic #95-108215BP		Two Story SFR - 1994 UBC	1996
New	Approved Basic #96-107423BP	Plan #1002A	Two Story SFR - 1994 UBC	1996
New	Approved Basic #96-103436BP		Rambler Style SFR - 1994 UBC	1996
New	Approved Basic #96-102793BP		SFR w/finished basement - 1994 UBC	1996
New	Rambler with a 2 car			1996
New	SFR Rambler w/2 car garage-1994 UBC			1996
New	SFR split w/ 2 car garage- 1994 UBC			1996
New	SFR Rambler w/2 car garage- 1994 UBC			1996
New	SFR Rambler w/ 2 car garage- 1994 UBC			1996
New	Approved Basic #96-103436BP		Rambler Style SFR - 1994 UBC	1996
New	Approved Basic #96-102778BP		Rambler Style SFR - 1994 UBC	1996
New	Approved Basic #96-102793BP		SFR w/finished basement - 1994 UBC	1996
New	Approved Basic #96-102778BP		Rambler Style SFR - 1994 UBC	1996
New	Approved Basic #96-102793BP		SFR w/finished basement - 1994 UBC	1996
New	Approved Basic #95-110380BP		SFR w/unfinished basement - 1994 UBC	1996
New	Approved Basic #96-102781BP		Rambler Style SFR - 1994 UBC	1996
New	Approved Basic #96-102793BP		SFR w/finished basement - 1994 UBC	1996
New	Approved Basic #96-109525BP	Plan #LC969	Two Story SFR - 1994 UBC	1996
New	Approved Basic #95-110380BP		SFR w/finished or unfinished basement - 1994 UBC	1996
New	Approved Basic #96-109525BP	Plan #LC969	Two Story SFR - 1994 UBC	1996
New	Two Story SFR - 1994 UBC			1996
New	Approved Basic #96-103436BP		Rambler Style SFR - 1994 UBC	1996
New	Approved Basic #96-102793BP		SFR w/finished basement - 1994 UBC	1996
New	Approved Basic #96-102781BP		Rambler Style SFR - 1994 UBC	1996
New	Approved Basic #96-102793BP		SFR w/finished basement - 1994 UBC	1996
New	Approved Basic #96-102781BP		Rambler Style SFR - 1994 UBC	1996
New	Approved Basic #96-103436BP		Rambler Style SFR - 1994 UBC	1996
New	Approved Basic #95-110380BP		SFR w/finished or unfinished basement - 1994 UBC	1996
New	Approved Basic #95-108215BP	(Elevation A&B approved)	Two Story SFR - 1994 UBC	1996
New	Approved Basic #95-108215BP	(Elevation A,B,C approved)	Two Story SFR - 1994 UBC	1996
New	Approved Basic #95-108215BP	(Elevation A,B,C approved)	Two Story SFR - 1994 UBC	1996
New	Rambler w/ 3 car			1996
New	Approved Basic #96-105617BP		Two Story SFR - 1994 UBC	1996
New	2 Story with a 2 car			1996
New	Approved Basic #96-105617BP		Two Story SFR -1994 UBC	1996
New	2-Story SFR w/attached Garage			1996
New	2-Story SFR			1996
New	SFR			1996

Accessory Dwelling Units

Index # - File Name: 1.0022 - Single Family Dwellings Data\_Snohomish County.pdf

New	Rambler Style SFR - 1994 UBC	1996
New	Rambler Style SFR - 1994 UBC	1996
New	2 story SFR 2. Eng - Jan V. Rohlik #27256	1996
New	Double Wide mobile	1996
New	Two Story SFR- 1994 UBC (Builders Plan #2450)	1996
New	SFR	1996
New	new SFR	1996
New	2 story w/ att garage	1996
New	2 Story with a 3 car	1996
New	SFR w/finished basement - 1994 UBC	1996
New	Approved Basic #95-109272BP Two Story SFR - 1994 UBC	1996
New	2589-sf Rambler w/attached Garage	1996
New	2 story SFR w/ 3 car garage- 1994 UBC	1996
New	2 Story SFR with attached garage	1996
New	Rambler Style SFR - 1994 UBC	1996
New	2 story SFR with attached garage	1996
New	Two Story SFR - 1994 UBC	1996
New	Approved Basic #96-105353BP Rambler Style SFR - 1994 UBC	1996
New	2300 sfr, 664 garage, 1994 UBC	1996
New	SFR	1996
New	Approved Basic #96-101222BP Two Story SFR - 1994 UBC	1996
New	Two Story SFR - 1994 UBC	1996
New	Approved Basic #95-108665BP Two Story SFR - 1994 UBC	1996
New	Two Story SFR - 1994 UBC	1996
New	2-story SFR w/attached garage	1996
New	Two Story SFR - 1994 UBC	1996
New	2-Story SFR w/attached Garage	1996
New	Approved Basic #96-105172BP Two Story SFR - 1994 UBC	1996
New	SFR w/finished basement (Builders Plan #333-4 3-car) Converted from plan check only to Bldg.	1996
New	Two Story SFR - 1994 UBC	1996
New	2 story sfr, garage	1996
New	Two Story SFR - 1994 UBC	1996
New	SFR WAS FINALLED 12/2/96 BY DOYLE BROWN - WAS MISTAKENLY REFILED UNTIL 5/14/97 - AF	1996
New	new SFR	1996
New	Two Story SFR - 1994 UBC	1996
New	2 story with a 3 car	1996
New	2-story SFR w/attached Gar.	1996
New	2 story SFR with attached garage	1996
New	Two Story SFR - 1994 UBC	1996
New	Two Story SFR - 1994 UBC	1996
New	Two Story SFR - 1994 UBC	1996
New	Two Story SFR - 1994 UBC	1996
New	Approved Basic #96-108800BP Plan #1490 Two Story SFR - 1994 UBC	1996
New	1505 sq. ft. 2-story w/410 sq. ft. garage and 96 sq. ft. covered deck/porch	1996
New	Approved Basic #96-108796BP Two Story SFR - 1994 UBC	1996
New	2 story SFR with attached garage	1996
New	2 story w/ att d garage	1996

Accessory Dwelling Units

Index # - File Name: 1.0022 - Single Family Dwellings Data\_Snohomish County.pdf

New	2 story SFR with attached garage		1996
New	Approved Basic #96-102786BP	Rambler Style SFR - 1994 UBC	1996
New	Approved Basic #96-102793BP	SFR w/finished basement - 1994 UBC	1996
New	Approved Basic #96-102793BP	SFR w/finished basement - 1994 UBC	1996
New	Approved Basic #96-102786BP	Rambler Style SFR - 1994 UBC	1996
New	Approved Basic #96-102793BP	SFR w/finished basement - 1994 UBC	1996
New	Approved Basic #96-102786BP	Rambler Style SFR - 1994 UBC	1996
New	Approved Basic #96-102793BP	SFR w/finished basement - 1994 UBC	1996
New	Approved Basic #95-110380BP	SFR w/unfinished basement - 1994 UBC	1996
New	Approved Basic #96-102778BP	Rambler Style SFR - 1994 UBC	1996
New	Approved Basic #96-102793BP	SFR w/finished basement - 1994 UBC	1996
New	Approved Basic #96-102781BP	Rambler Style SFR - 1994 UBC	1996
New	Approved Basic #96-102786BP	Rambler Style SFR - 1994 UBC	1996
New	Approved Basic #96-102778BP	Rambler Style SFR - 1994 UBC	1996
New	Approved Basic #96-102781BP	Rambler Style SFR - 1994 UBC	1996
New	Approved Basic #96-103436BP	Rambler Style SFR - 1994 UBC	1996
New	Approved Basic #96-102786BP	Rambler Style SFR - 1994 UBC	1996
New	Approved Basic #96-102781BP	Rambler Style SFR - 1994 UBC	1996
New	Rambler Style SFR - 1994 UBC		1996
New	2 Story with a 3 car-1994 UBC		1996
New	2720 SF SFR - Rambler with attached garage		1996
New	2 story SFR with attached garage		1996
New	2 story SFR with attached garage		1996
New	1670 sq. ft. SFR w/1156 sq. ft. garage		1996
New	Two Story SFR - 1994 UBC		1996
New	2 story SFR with attached garage		1996
New	Two Story SFR with Attached Garage		1996
New	Rambler w/3 car		1996
New	Approved Basic #96-101623BP	Two Story SFR - 1994 UBC	1996
New	2 Story with a 3 car		1996
New	2 Story with a 3 car		1996
New	2938 sq. ft. 2-story w/829 sq. ft. garage		1996
New	Rambler with a 3 car		1996
New	Two Story SFR with attached Garage		1996
New	SFR		1996
New	1951 SF SFR with attached garage		1996
New	new SFR		1996
New	Rambler with a 2 car garage		1996
New	Two Story SFR - 1994 UBC		1996
New	Two Story SFR - 1994 UBC		1996
New	Two Story SFR - 1994 UBC		1996
New	Two Story SFR - 1994 UBC		1996
New	Two Story SFR - 1994 UBC		1996
New	Two Story SFR - 1994 UBC	(Builders plan #SC03-94)	Approved Basic #95-106266BP
New	Two Story SFR - 1994 UBC	(Builders plan #SC03-94)	Approved Basic #95-106266BP
New	Approved Basic #95-106597BP	Two Story SFR - 1994 UBC	(Builders plan #SC06A-94)
New	SFR		1996
New	Rambler Style SFR w/attached garage.		1996

Accessory Dwelling Units

Index # - File Name: 1.0022 - Single Family Dwellings Data\_Snohomish County.pdf

New	27 x48 Oak Grove Fleetwood (1996)	Application for TD filed under #96-108697TD	1996
New	MH FINALLED 10/17/96; REF GRADING PERMIT, STILL OPEN AT THIS CLOSING PER JACKIE LONG		1996
New	VIOLATION: MacQuarrie - please give copy of permit to DKN when issued	Permit for existing 10	1996
New	Approved Basic #96-105527BP	Two Story SFR - 1994 UBC	1996
New	2 story w/ 3 car		1996
New	2 Story with a 3 car		1996
New	Two Story SFR - 1994 UBC		1996
New	Daylight Rambler with 2 car		1996
New	Rambler Style SFR - 1994 UBC		1996
New	Single Story SFR with Attached Garage		1996
New	2 story SFR with attached garage		1996
New	SFR		1996
New	28 X 70 Redmond Windsong	1996	1996
New	2 Story with a 3 car garage		1996
New	2 story w/ 3 car		1996
New	2 story SFR with attached garage		1996
New	2 story SFR with attached garage		1996
New	38 x 60 Waverly Creast		1996
New	27x48 (1996) Golden West		1996
New	Duplex		1996
New	Two Story SFR - 1994 UBC		1996
New	Two Story SFR - 1994 UBC	Approved Basic #95-106500BP	1996
New	Approved Basic #96-104687BP	Two Story SFR - 1994 UBC	1996
New	Pending Basic #96-103584BP	Two Story SFR - 1994 UBC	1996
New	Approved Basic #96-101446BP	Two Story SFR - 1994 UBC	1996
New	Two Story SFR - 1994 UBC		1996
New	Two Story SFR with Attached Garage		1996
New	Approved Basic #96-101447BP	Two Story SFR - 1994 UBC	1996
New	Two Story SFR - 1994 UBC	Plan 758CD	1996
New	Two Story SFR - 1994 UBC	Approved Basic #95-106500BP	1996
New	Two Story SFR - 1994 UBC		1996
New	Approved Basic #96-101446BP	Plan #127 A,B,C,D,E Two Story SFR - 1994 UBC	1996
New	Two Story SFR - 1994 UBC	Approved Basic #95-106500BP	1996
New	Two Story SFR - 1994 UBC		1996
New	Two Story SFR - 1994 UBC		1996
New	2 Story SFR w/attached Garage		1996
New	SFR w/unfinished basement	1994 UBC	1996
New	Approved Basic #96-103338BP	Two Story SFR - 1994 UBC	1996
New	Approved Basic #96-108573BP	Two Story SFR - 1994 UBC	1996
New	Approved Basic #96-105086BP	(Plan 2725 A/B) Two Story SFR - 1994 UBC	1996
New	Approved Basic #96-105087BP	(Plan 2705 A,B,C) Two Story SFR - 1994 UBC	1996
New	Approved Basic #96-103338BP	Two Story SFR -1994 UBC	1996
New	Approved Basic #96-103338BP	Plan #2645 A/B Two Story SFR -1994 UBC	1996
New	Approved Basic #96-103338BP	Plan #2645 A/B Two Story SFR -1994 UBC	1996
New	Approved Basic #96-105087BP	(Plan 2705 A,B,C) Two Story SFR - 1994 UBC	1996
New	Approved Basic #96-103338BP	Plan #2645 A/B Two Story SFR - 1994 UBC	1996
New	Approved Basic #96-103338BP	Two Story SFR -1994 UBC	1996



Accessory Dwelling Units

Index # - File Name: 1.0022 - Single Family Dwellings Data\_Snohomish County.pdf

New	Two Story SFR - 1994 UBC		1996	
New	Approved Basic #96-103338BP	Plan #2645 A/B	Two Story SFR -1994 UBC	1996
New	24 x 60 Marlette - 1971		1996	
New	SFR w/unfinished basement - 1994 UBC		1996	
New	SFR		1996	
New	Approved Basic #96-103338BP	Two Story SFR -1994 UBC	1996	
New	Approved Basic #96-103537BP	Two Story SFR - 1994 UBC	1996	
New	sfr, 1126 sf main, 926 sf 2nd floor, 840 sf garage		1996	
New	Approved Basic #96-101230BP	Two Story SFR - 1994 UBC	1996	
New	2 Story with a 3 car		1996	
New	.		1996	
New	2-Story SFR w/attached garage		1996	
New	Single story sfr		1996	
New	MOBILE HOME		1996	
New	new SFR		1996	
New	1816 sq. ft. 2-story w/588 sq. ft. garage		1996	
New	1574-sf SFR w/attached garage		1996	
New	Rambler Style SFR - 1994 UBC		1996	
New	new duplex		1996	
New	SFR		1996	
New	Approved Basic #96-101277BP	Two Story SFR - 1994 UBC	1996	
New	1281-sf w/attached garage		1996	
New	Approved Basic #96-101277BP	Two Story SFR - 1994 UBC	1996	
New	Pending Basic #96-105448BP	Two Story SFR - 1994 UBC	1996	
New	2 Story with a 3 car		1996	
New	Approved Basic #96-103584BP	Two Story SFR - 1994 UBC	1996	
New	28 x 60 , 1997 Silver Crest MH		1996	
New	SFR		1996	
New	Approved Basic #96-109755BP	Plan 1278	Two Story SFR - 1994 UBC	1996
New	2530 sq. ft. 2-story w/ 515 sq.,. ft.,. garage		1996	
New	2360 sq. ft. 2-story w/ 715 sq. ft. garage		1996	
New	new SFR		1996	
New	New SFR		1996	
New	28 x 60 Fleetwood, 1996.		1996	
New	Two Story SFR - 1994 UBC		1996	
New	2 story SFR with attached garage		1996	
New	2370 sq. ft. 2-story w/644 sq. ft. garage and 144 sq. ft. covered deck/porch		1996	
New	Approved Basic #96-109958BP	Plan 6475A	Two Story SFR - 1994 UBC	1996
New	2 Story SFR with attached garage		1996	
New	2142 sq. ft. 2-story w/704 sq. ft. garage		1996	
New	Two Story SFR - 1994 UBC		1996	
New	2 Story SFR w/ garage, covered deck & deck		1996	
New	1788-sf Rambler w/attached garage		1996	
New	2 story w/ garage, 1994 UBC		1996	
New	Approved Basic #96-107909BP	Rambler Style SFR - 1994 UBC	1996	
New	Approved Basic #96-100746BP	Rambler Style SFR - 1994 UBC	1996	
New	Approved Basic #96-102270BP	Two Story SFR - 1994 UBC	1996	

Accessory Dwelling Units

Index # - File Name: 1.0022 - Single Family Dwellings Data\_Snohomish County.pdf

New	Approved Basic #96-102270BP	Two Story SFR - 1994 UBC	1996
New	Approved Basic #96-102270BP	Two Story SFR - 1994 UBC	1996
New	Approved Basic #96-102270BP	Two Story SFR - 1994 UBC	1996
New	new SFR		1996
New	2 story sfr w/ garage		1996
New	Approved Basic #96-106959BP	Two Story SFR - 1994 UBC	1996
New	Approved Basic #96-106959BP	Two Story SFR - 1994 UBC	1996
New	Approved Basic #96-103264BP	Two Story SFR - 1994 UBC	1996
New	Approved Basic #95-106646BP	Two Story SFR - 1994 UBC	1996
New	Approved Basic #95-108810BP	Rambler Style SFR - 1994 UBC	1996
New	Approved Basic #96-102874BP	Two Story SFR - 1994 UBC	1996
New	Approved Basic #96-106959BP	Two Story SFR - 1994 UBC	1996
New	new SFR		1996
New	Approved Basic #95-106646BP	Two Story SFR - 1994 UBC	1996
New	Approved Basic #95-106646BP	Two Story SFR - 1994 UBC	1996
New	Approved Basic #95-108810BP	Rambler Style SFR - 1994 UBC	1996
New	Approved Basic #95-109726BP	(THIS BASIC IS ONLY APPROVED FOR 2 CAR) Two Story SFR - 19	1996
New	Approved Basic #96-102270BP	Two Story SFR - 1994 UBC	1996
New	Approved Basic #95-109726BP	(THIS BASIC IS ONLY APPROVED FOR 2 CAR) Two Story SFR - 19	1996
New	Approved Basic #95- 108133BP	(Ref previous permit - # 274553) Tri-Level SFR - 1994 UBC	1996
New	Approved Basic #96-100746BP	Rambler Style SFR - 1994 UBC	1996
New	Approved Basic #95-109726BP	(THIS BASIC IS ONLY APPROVED FOR 2 CAR) Two Story SFR - 19	1996
New	Approved Basic #95-108527BP	SFR w/unfinished basement 1994 UBC	1996
New	Approved Basic #96-109755BP	Plan 1278 Two Story SFR - 1994 UBC	1996
New	SFR w/unfinished lower floor - 1994 UBC		1996
New	Approved Basic #95-108527BP	SFR w/unfinished basement 1994 UBC	1996
New	Approved Basic #95-108526BP	SFR w/unfinished basement 1994 UBC	1996
New	Approved Basic #95-108527BP	SFR w/unfinished basement 1994 UBC	1996
New	Approved Basic #95-108527BP	SFR w/unfinished basement 1994 UBC	1996
New	Approved Basic #95-108526BP	SFR w/unfinished basement 1994 UBC	1996
New	Approved Basic #95-108527BP	SFR w/unfinished basement 1994 UBC	1996
New	Approved Basic #95-108526BP	SFR w/unfinished basement 1994 UBC	1996
New	Approved Basic #95-108527BP	SFR w/unfinished basement 1994 UBC	1996
New	Approved Basic #95-108526BP	SFR w/unfinished basement 1994 UBC	1996
New	FINAL NOT INPUT TO AMANDA UNTIL 6/9/97 - AF	Approved Basic #95-108527BP SFR w/unfin	1996
New	Approved Basic #96-109755BP	Plan 1278 Two Story SFR - 1994 UBC	1996
New	Approved Basic #95-108527BP	SFR w/unfinished basement 1994 UBC	1996
New	Approved Basic #95-108526BP	SFR w/unfinished basement 1994 UBC	1996
New	Approved Basic #95-108527BP	SFR w/unfinished basement 1994 UBC	1996
New	Approved Basic #95-108527BP	SFR w/unfinished basement 1994 UBC	1996
New	Approved Basic #95-108526BP	SFR w/unfinished basement 1994 UBC	1996
New	Approved Basic #95-108527BP	SFR w/unfinished basement 1994 UBC	1996
New	Approved Basic #95-108526BP	SFR w/unfinished basement 1994 UBC	1996
New	Approved Basic #95-108527BP	SFR w/unfinished basement 1994 UBC	1996
New	Approved Basic #95-108526BP	SFR w/unfinished basement 1994 UBC	1996
New	Approved Basic #95-108527BP	SFR w/unfinished basement 1994 UBC	1996
New	Rambler Style SFR - 1994 UBC		1996
New	26 8 x52 1995 Marlette Mobile Home		1996
New	Approved Basic 95-107174BP	(Builders Plan #1202) 1994 UBC Rambler Style - Duplex	1996
New	2287 sq. ft 2-story w/720 sq.ft attached garage		1996

Accessory Dwelling Units

Index # - File Name: 1.0022 - Single Family Dwellings Data\_Snohomish County.pdf

New	Approved Basic #96-102270BP	Two Story SFR - 1994 UBC	1996
New	Approved Basic #95-108812BP	Two Story SFR - 1994 UBC	1996
New	Approved Basic #96-105488BP	Rambler Style SFR - 1994 UBC	1996
New	Approved Basic #96-102874BP	Two Story SFR - 1994 UBC	1996
New	Two Story SFR - 1994 UBC		1996
New	2-Story SFR w/attached Garage		1996
New	2 story w/ unfin bsmt & 3 car garage		1996
New	SFR		1996
New	2 story SFR with attached garage		1996
New	Approved Basic #96-103537BP	Two Story SFR - 1994 UBC	1996
New	Approved Basic #95-109581-003BP	(Tulip) 0 lot line structure - 1994 UBC (Two Story)	1996
New	Approved Basic #95-109581-003BP	(Tulip) 0 lot line structure - 1994 UBC (Two Story)	1996
New	SFR		1996
New	1996 27 x 52 Fleetwood		1996
New	Two Story SFR - 1994 UBC		1996
New	2250 sq. ft. 2-story w/634 sq. ft. garage		1996
New	1727 sq. ft. 2-story w/615 sq. ft. garage and 478 sq. ft. covered porch/deck		1996
New	2536 SF Duplex		1996
New	SFR		1996
New	1260 SF SFR with attached garage		1996
New	new SFR, supercedes application 95-107412		1996
New	Two Story SFR - 1994 UBC		1996
New	Approved Basic #96-105584BP	Two Story SFR - 1994 UBC	1996
New	Approved Basic #96-104208BP	Two Story SFR - 1994 UBC	1996
New	Approved Basic #96-104563BP	Two Story SFR - 1994 UBC	1996
New	Rambler Style SFR - 1994 UBC		1996
New	VOIDED PERMIT #95-108437	Approved Basic #95-106336BP Two Story SFR - 1994 UBC	1996
New	Approved Basic #95-106333BP	Two Story SFR - 1994 UBC	1996
New	Two Story SFR - 1994 UBC ( Archived to Tax Account file 4/21/97 by Kim Carlson.)		1996
New	Approved Basic #96-105586BP	Two Story SFR - 1994 UBC	1996
New	Approved Basic #96-104567BP	Two Story SFR - 1994 UBC	1996
New	Approved Basic #96-105591BP	Two Story SFR - 1994 UBC	1996
New	Approved Basic #96-104562BP	Two Story SFR - 1994 UBC	1996
New	Approved Basic #96-104564	Two Story SFR - 1994 UBC	1996
New	Approved Basic #96-105590BP	Two Story SFR - 1994 UBC	1996
New	Approved Basic #96-104208BP	Two Story SFR - 1994 UBC	1996
New	Approved Basic #96-104562BP	Two Story SFR - 1994 UBC	1996
New	Approved Basic #96-105586BP	Two Story SFR - 1994 UBC	1996
New	Approved Basic #96-104208BP	Two Story SFR - 1994 UBC	1996
New	Approved Basic #96-105590BP	Two Story SFR - 1994 UBC	1996
New	Approved Basic #95-106333BP	Option Approved - 3rd car & floor joists option 9/15/95 Two S	1996
New	Approved Basic #96-104788BP	Two Story SFR - 1994 UBC	1996
New	Approved Basic #96-104208BP	Two Story SFR - 1994 UBC	1996
New	Approved Basic #96-105586BP	Plan #KTH 3-B Two Story SFR - 1994 UBC	1996
New	Tri Level with a 2 car garage		1996
New	new SFR		1996
New	new SFR		1996

Accessory Dwelling Units

Index # - File Name: 1.0022 - Single Family Dwellings Data\_Snohomish County.pdf

New	Two Story SFR w/unfinished basement - 1994 UBC	1996
New	1285-SF Rambler Style SFR w/attached garage	1996
New	Rambler with attached garage	1996
New	Rambler w/ 2 car	1996
New	2060 sq. ft. Rambler w/582 sq. ft. attached garage and 510 sq. ft. covered porch	1996
New	28 x 56 1996 Barrington	1996
New	Two Story SFR - 1994 UBC	1996
New	14 x 64 1976 Kentwood	1996
New	2 - Story SFR with attached Garage	1996
New	2 story SFR with attached garage	1996
New	3540 sq. ft. 2-story w/1240 sq. ft., garage RSP 3-10-97	1996
New	RESIDENCE/GARAGE. See new permit, 99-113051, issued 9/7/99.	1996
New	SFR w/finished basement - 1994 UBC	1996
New	2 story no garage	1996
New	56 x 40 1997 Northstar. Work cont. on 99-104748.	1996
New	Reference 94-240260 AB	1996
New	2724 sq. ft 2-story, with 708 sq. ft. attached garage	1996
New	2 Story with a 3 car	1996
New	SFR	1996
New	2 story w 2 car	1996
New	SFR	1996
New	SFR	1996
New	2540 sq. ft.2 storey w/807 sq. ft garage	1996
New	Two Story SFR - 1994 UBC Changed to LPG heat - 7/21/97 - Revised Plans and Fees	1996
New	2-Story SFR w/attached Garage	1996
New	Double Wide Mobile	1996
New	SFR	1996
New	SFR. (Finaled by M.Palmer.)	1996
New	2 Story Duplex with 1 car garages	1996
New	30x60; 1990 Skyline MH	1996
New	Two Story SFR with finished basement and attached garage	1996
New	Rambler w/ attached garage, covered deck	1996
New	2424sq. ft. duplex w/ 880 sq. ft. garage	1996
New	Single family residence with attached pole-type Carport	1996
New	28x53 (1996) Palm Harbor #3049	1996
New	Cardinal Estates MH Park - Space 16	1996
New	Split-level SFR - 1994 UBC	1996
New	Approved Basic #96-108010BP Split Level SFR - 1994 UBC	1996
New	Approved Basic #96-108010BP Split Level SFR - 1994 UBC	1996
New	2-Story SFR w/attached Garage	1996
New	Midway Garden MH Park - Space 2 26x48 (1996) Marlette	1996
New	Two Story SFR - 1994 UBC Plan #1871	1996
New	Approved Basic #96-104459BP Plan #1800 Two Story SFR - 1994 UBC	1996
New	Approved Basic #95-108142BP SFR w/finished basement - 1994 UBC (partial unfinished)	1996
New	Approved Basic #96-105566BP Two Story SFR - 1994 UBC	1996
New	Approved Basic #96-101863BP Two Story SFR - 1994 UBC	1996
New	Approved Basic #96-104459BP Plan #1800 Two Story SFR - 1994 UBC	1996

Accessory Dwelling Units

Index # - File Name: 1.0022 - Single Family Dwellings Data\_Snohomish County.pdf

New	Approved Basic #96-100583BP	Plan #1905	Two Story SFR - 1994 UBC	1996
New	Approved Basic #96-101863BP		Two Story SFR - 1994 UBC	1996
New	Approved Basic #95-108142BP		SFR w/finished basement - 1994 UBC (partial unfinished)	1996
New	Approved Basic #96-105385BP		Two Story SFR - 1994 UBC	1996
New	Approved Basic #96-101863BP		Two Story SFR - 1994 UBC	1996
New	Approved Basic #96-105385BP		Two Story SFR - 1994 UBC	1996
New	Approved Basic 95-107174BP	(Builders Plan #1202)	1994 UBC Rambler Style - Duplex	1996
New	Approved Basic 95-107174BP	(Builders Plan #1202)	1994 UBC Rambler Style - Duplex	1996
New	Approved Basic 95-107174BP	(Builders Plan #1202)	1994 UBC Rambler Style - Duplex	1996
New	12 x 50 1973 Fleetwood		Mobile Home	1996
New	Double Wide Mobile			1996
New	New Double Wide Mobile Home	24 X 50 1987 Liberty w/tipout	(originally permit was for 28 X 4	1996
New	SFR			1996
New	2-Story SFR w/attached garage			1996
New	SFR			1996
New	Two Story SFR with Attached Garage			1996
New	850-sf Detached Accessory Apartment			1996
New	2 story w/2 car			1996
New	24 x 32 1974 Statler			1996
New	1996 28 x 66 Brookwood			1996
New	26x44 (1996) Berkshire			1996
New	28 x 66 - 1997-Skyline		Mobile Home	1996
New	2240 sq. ft. 2-story w/600 sq. ft. garage			1996
New	2 story w/2 car			1996
New	2 Story w/2 car			1996
New	2-Story SFR w/attached garage			1996
New	4th Ave. W. Estates MH Park - Space 24			1996
New	Two Story SFR - 1994 UBC			1996
New	Two Story Duplex - 1994 UBC	RSP 3-11-97 revising drainage - routed to site	mlo	1996
New	Rambler Style SFR - 1994 UBC			1996
New	Approved Basic #95-109377BP		Two Story SFR - 1994 UBC	1996
New	1996 Palm Harbor			1996
New	Rambler with a 2 car			1996
New	28x56 (1996) Golden West			1996
New	28x56 (1996) Golden West			1996
New	28x66 (1996) Golden West			1996
New	Approved Basic #96-105683BP		Two Story SFR - 1994 UBC	1996
New	2-Story SFR w/Attached garage			1996
New	Two Story SFR - 1994 UBC			1996
New	Two Story SFR - 1994 UBC			1996
New	2-Story SFR w/attached Garage			1996
New	Two Story SFR - 1994 UBC			1996
New	2 Story SFR with attached garage			1996
New	2-Story SFR w/Attached garage			1996
New	3090 sq. ft. 2 story, w/735 sq. ft. garage			1996
New	2 story SFR			1996
New	40 x 62 TD -MH			1996

Accessory Dwelling Units

Index # - File Name: 1.0022 - Single Family Dwellings Data\_Snohomish County.pdf

New	SFR w/unfinished basement - 1994 UBC	Plan #1430	1996
New	Approved Basic #96-107398BP	Rambler Style SFR - 1994 UBC	1996
New	Approved Basic #96-105865BP	SFR w/finished or unfinished basement - 1994 UBC	1996
New	Approved Basic #96-105868BP	SFR w/ finished of unfinished basement - 1994 UBC	1996
New	SFR w/finished or unfinished basement - 1994 UBC	Plan #1733	1996
New	SFR no attached garage		1996
New	Two Story SFR with Attached Garage		1996
New	Approved Basic #96-102452BP	SFR Rambler w/2 or 3 car garage - 1994 UBC	1996
New	Approved Basic #96-105548BP	SFR w/finished basement - 1994 UBC	1996
New	Approved Basic #96-102452BP	Two Story SFR w/2 or 3 car garage - 1994 UBC	1996
New	Rambler Style SFR - 1994 UBC		1996
New	SFR- with attached Garage		1996
New	Two Story SFR - 1994 UBC		1996
New	Rambler Style SFR - 1994 UBC		1996
New	2 Story SFR with attached garage		1996
New	Approved Basic #96-102452BP	SFR Rambler w/ 2or 3 car garage - 1994 UBC	1996
New	1452 sq. ft. rambler w/416 sq. ft. finished basement w/594 sq. ft. garage		1996
New	Rambler with unfinished daylight basement and attached garage		1996
New	Approved Basic #96-106962BP	SFR w/finished basement - 1994 UBC	1996
New		#NAME?	1996
New	Rambler style SFR w/attached Garage		1996
New	Rambler Style SFR - 1994 UBC		1996
New	Approved Basic #96-107650BP	Rambler Style SFR - 1994 UBC	1996
New	Approved Basic #96-107655BP	SFR w/unfinished basement - 1994 UBC	1996
New	Daylight Basement SFR w/attached Garage		1996
New	1-Story SFR w/attached Garage		1996
New	2 story SFR with attached garage		1996
New	New 2 Story SFR		1996
New	26 -8 x 44 1996 Marlette Mobile Home		1996
New	SFR		1996
New	Single Story SFR with attached Garage		1996
New	Single Story SFR with attached Garage		1996
New	27 x 66 Golden West Mobile Home		1996
New	27 X 48 Fleetwood 1996		1996
New	24 X 60 Barrington 1985	Permit transfered to Kathleen Nelson 4/17/97 - Affidavit on file	1996
New	Approved Basic #96-105882BP	Two Story SFR - 1994 UBC	1996
New	Approved Basic #96-105882BP	Two Story SFR - 1994 UBC	1996
New	Approved Basic #96-105882BP	Two Story SFR - 1994 UBC	1996
New	Approved Basic #96-105880BP	Two Story SFR - 1994 UBC	1996
New	Rambler w /3 car		1996
New	2265 sq. ft. 2-story w/428 sq. ft. garage and 300 sq. ft. covered porch/deck		1996
New	Double Wide Mobile		1996
New	28 x 48 Redman 1996		1996
New	28 x 52 Marlette		1996
New	28x52 Marlette		1996
New	28x60; 1996 Marlette		1996
New	28x56 Goldenwest Mobile Home		1996

Accessory Dwelling Units

Index # - File Name: 1.0022 - Single Family Dwellings Data\_Snohomish County.pdf

New	40x66 (1996) Golden West		1996
New	2 Story SFR with attached garage		1996
New	SFR		1996
New	Installation of 1974 14 x 60 New Moon by Redman		1996
New	2 Story w 3 car		1996
New	SFR		1996
New	28 X 56 Redman 1980		1996
New	Approved Basic #96-108253BP	Plan #1885 Tri-Level SFR - 1994 UBC	1996
New	Approved Basic #96-108253BP	Plan #1885 Tri-Level SFR - 1994 UBC	1996
New	THIS PERMIT WAS CREATED BUT NOT ISSUED ; IT WAS INSPECTED AND FINALLED BY TOM BRYA		1996
New	Two Story SFR - 1994 UBC	Plan #1934 A/2	1996
New	Two Story SFR - 1994 UBC		1996
New	Approved Basic #96-108254BP	Two Story SFR - 1994 UBC	1996
New	Approved Basic #96-108251BP	Plan #1889/2 Two Story SFR - 1994 UBC	1996
New	Approved Basic #96-108254BP	Two Story SFR - 1994 UBC	1996
New	Approved Basic #96-108251BP	Plan #1889/2 Two Story SFR - 1994 UBC	1996
New	Tri-level SFR - 1994 UBC	Plan 1885	1996
New	Two Story SFR - 1994 UBC		1996
New	Two Story SFR - 1994 UBC		1996
New	Rambler 2/unfin bsmt & 2 car		1996
New	Approved Basic #96-109489BP	Plan #1922 Two Story SFR - 1994 UBC	1996
New	Approved Basic #96-101352BP	Two Story SFR - 1994 UBC	1996
New	Two Story SFR - 1994 UBC	Plan 1947	1996
New	Approved Basic #96-109489BP	Plan #1922 Two Story SFR - 1994 UBC	1996
New	Approved Basic #96-109498BP	Plan #1920 Two Story SFR - 1994 UBC	1996
New	Approved Basic #96-109489BP	Plan #1922 Two Story SFR - 1994 UBC	1996
New	Approved Basic #96-101352BP	Two Story SFR - 1994 UBC	1996
New	Approved Basic #96-109507BP	Plan #2005 Two Story SFR - 1994 UBC	1996
New	Approved Basic #96-108379BP	Two Story SFR - 1994 UBC	1996
New	Approved Basic #96-109482BP	Plan 1806 Rambler Style SFR - 1994 UBC	1996
New	Approved Basic #96-109507BP	Plan #2005 Two Story SFR - 1994 UBC	1996
New	Approved Basic #96-101352BP	Two Story SFR - 1994 UBC	1996
New	Approved Basic #96-109477BP	Plan 1947 Two Story SFR - 1994 UBC	1996
New	Approved Basic #96-109489BP	Plan #1922 Two Story SFR - 1994 UBC	1996
New	Approved Basic #96-108379BP	Two Story SFR - 1994 UBC	1996
New	Two Story SFR - 1994 UBC	Plan #1922	1996
New	Approved Basic #96-109477BP	Plan 1947 Two Story SFR - 1994 UBC	1996
New	Approved Basic #96-109489BP	Plan #1922 Two Story SFR - 1994 UBC	1996
New	Approved Basic #96-109482BP	Plan 1806 Rambler Style SFR - 1994 UBC	1996
New	Approved Basic #96-109498BP	Plan #1920 Two Story SFR - 1994 UBC	1996
New	Approved Basic #96-109477BP	Plan 1947 Two Story SFR - 1994 UBC	1996
New	Approved Basic #96-109498BP	Plan #1920 Two Story SFR - 1994 UBC	1996
New	Two Story SFR - 1994 UBC	Plan 1920	1996
New	Farm worker s dwelling		1996
New	SFR w/finished basement - 1994 UBC		1996
New	SFR		1996
New	Approved Basic #95-110105BP	Two Story SFR - 1994 UBC	1996

Accessory Dwelling Units

Index # - File Name: 1.0022 - Single Family Dwellings Data\_Snohomish County.pdf

New	Two Story SFR - 1994 UBC		(Plan #1887	1996
New	Two Story SFR - 1994 UBC	Plan #9310-1		1996
New	Approved Basic #96 110235BP	Plan 1913	Rambler Style SFR - 1994 UBC	1996
New	Approved Basic #96-110590BP	Plan 1887-S	Two Story SFR - 1994 UBC	1996
New	Approved Basic #96-108498BP	Plan #1813	Rambler Style SFR - 1994 UBC	1996
New	Rambler Style SFR - 1994 UBC			1996
New	Two Story SFR - 1994 UBC	Plan 1887-S		1996
New	Two Story SFR - 1994 UBC	Plan #9302		1996
New	Approved Basic #96-109288BP	Two Story SFR - 1994 UBC	Plan 1887 -2/3	1996
New	Two Story SFR - 1994 UBC	0 Lot Line Structure		1996
New	Approved Basic #96-101409BP	Two Story SFR - 1994 UBC	(0 lot line structure)	1996
New	Approved Basic #96-101411BP	Two Story SFR - 1994	(0 lot line structure)	1996
New	Approved Basic #96-101411BP	Two Story SFR - 1994	(0 lot line structure)	1996
New	Approved Basic #96-101409BP	Two Story SFR - 1994 UBC	(0 lot line structure)	1996
New	Approved Basic #96-101409BP	Two Story SFR - 1994 UBC	(0 lot line structure)	1996
New	Approved Basic #96-107201BP	0 Lot Line Structure	Two Story SFR - 1994 UBC	1996
New	Approved Basic #96-107201BP	0 Lot Line Structure	Two Story SFR - 1994 UBC	1996
New	Approved Basic #96-101411BP	Two Story SFR - 1994	(0 lot line structure)	1996
New	Approved Basic #96-101411BP	Two Story SFR - 1994	(0 lot line structure)	1996
New	Approved Basic #96-101411BP	Two Story SFR - 1994	(0 lot line structure)	1996
New	Approved Basic #96-101411BP	Two Story SFR - 1994	(0 lot line structure)	1996
New	Approved Basic #96-107201BP	0 Lot Line Structure	Two Story SFR - 1994 UBC	1996
New	Approved Basic #96-107201BP	0 Lot Line Structure	Two Story SFR - 1994 UBC	1996
New	Approved Basic #96-101411BP	Two Story SFR - 1994	(0 lot line structure)	1996
New	Approved Basic #96-101411BP	Two Story SFR - 1994	(0 lot line structure)	1996
New	Approved Basic #96-107201BP	0 Lot Line Structure	Two Story SFR - 1994 UBC	1996
New	Approved Basic #96-107201BP	0 Lot Line Structure	Two Story SFR - 1994 UBC	1996
New	Approved Basic #96-107201BP	0 Lot Line Structure	Two Story SFR - 1994 UBC	1996
New	Approved Basic #96-107201BP	0 Lot Line Structure	Two Story SFR - 1994 UBC	1996
New	28 x 52 1996 Redman MH in Crystal Tree Village			1996
New	Approved Basic #96-110016BP	Plan 2504	Two Story SFR - 1994 UBC	1996
New	Two Story SFR - 1994 UBC			1996
New	Approved Basic #95-110544BP	2 story SFR-2 or 3 car garage-	1994 UBC	1996
New	1 story duplex w/ garages			1996
New	2 Story w/ 2 car			1996
New	29 X 66 Marlette 1996			1996
New	Approved Basic #95-109591BP	Two Story SFR - 1994 UBC		1996
New	Two Story SFR - 1994 UBC	Plan #1887-S		1996
New	Two Story SFR - 1994 UBC	Plan #1917		1996
New	Approved Basic #96-109132BP	Plan #2154	Two Story SFR - 1994 UBC	1996
New	2-Story Duplex w/attached Garage.			1996
New	28x52 1997 Marlett			1996
New	Two Story SFR with attached Garage			1996
New	2 Story w/ 2 car			1996
New	1982, 28x56, Fuqua Prestigeo			1996
New	28 x 56 , 1996 Skyline Cedar Cove MH			1996
New	1659 SF SFR. Ref. 96-101152 AB, 96-101153 AB and (95-110906CT-grading)			1996



Accessory Dwelling Units

Index # - File Name: 1.0022 - Single Family Dwellings Data\_Snohomish County.pdf

New	SFR w/attached garage		1996
New	Approved Basic #96-106948BP	Rambler Style SFR - 1994 UBC	1996
New	Approved Basic #96-106948BP	Rambler Style SFR - 1994 UBC	1996
New	Two Story SFR - 1994 UBC		1996
New	2 Story with a 2 car		1996
New	Rambler with a 2 car		1996
New	Two Story SFR - 1994 UBC		1996
New	Approved Basic #96-106948BP	Rambler Style SFR - 1994 UBC	1996
New	Approved Basic #96-104181BP	Two Story SFR - 1994 UBC	1996
New	Approved Basic #96-104613BP	Two Story SFR - 1994 UBC	1996
New	Two Story SFR - 1994 UBC		1996
New	Approved Basic #96-106945BP	Two Story SFR - 1994 UBC	1996
New	SFR w/unfinished basement - 1994 UBC		1996
New	new SFR		1996
New	SFR		1996
New	Approved Basic #95-109460BP	Two Story Duplex - 1994 UBC	1996
New	new SFR		1996
New	1032 sq. ft. SFR w/504 sq. ft. attached garage		1996
New	SFR		1996
New	SFR with attached garage		1996
New	Approved Basic #96-101124BP	SFR w/unfinished basement - 1994 UBC	1996
New	Approved Basic #96-110241BP	Plan 1452 Rambler Style SFR - 1994 UBC	1996
New	Approved Basic #96-101124BP	SFR w/unfinished basement - 1994 UBC	1996
New	Approved Basic #96-100816BP	SFR w/finished basement - 1994 UBC	1996
New	Approved Basic #96-110241BP	Plan 1452 Rambler Style SFR - 1994 UBC	1996
New	Approved Basic #96-100816BP	SFR w/finished basement - 1994 UBC	1996
New	Approved Basic #96-101124BP	SFR w/unfinished basement - 1994 UBC	1996
New	Approved Basic #96-100376BP	Rambler Style SFR - 1994 UBC	1996
New	Approved Basic #96-101124BP	SFR w/unfinished basement - 1994 UBC	1996
New	Approved Basic #96-101119BP	Ramble Style SFR - 1994 UBC	1996
New	Approved Basic #96-100816BP	SFR w/finished basement - 1994 UBC	1996
New	Approved Basic #96-100373BP	SFR w/unfinished basement - 1994 UBC	1996
New	Approved Basic #96-100816BP	SFR w/finished basement - 1994 UBC	1996
New	Approved Basic #96-101124BP	SFR w/unfinished basement - 1994 UBC	1996
New	Approved Basic #96-101124BP	SFR w/unfinished basement - 1994 UBC	1996
New	Approved Basic #96-100816BP	SFR w/finished basement - 1994 UBC	1996
New	Approved Basic #96-100376BP	Rambler Style SFR - 1994 UBC	1996
New	Approved Basic #96-101124BP	SFR w/unfinished basement - 1994 UBC	1996
New	Approved Basic #96-100816BP	SFR w/finished basement - 1994 UBC	1996
New	Approved Basic #96-101124BP	SFR w/unfinished basement - 1994 UBC	1996
New	Approved Basic #96-101124BP	SFR w/unfinished basement - 1994 UBC	1996
New	Approved Basic #96-100816BP	SFR w/finished basement - 1994 UBC	1996
New	Approved Basic #96-101124BP	SFR w/unfinished basement - 1994 UBC	1996
New	Rambler Style SFR - 1994 UBC		1996
New	Approved Basic #96-100816BP	SFR w/finished basement - 1994 UBC	1996
New	Rambler Style SFR - 1994 UBC		1996
New	Split Level with a 2 car - 1994 UBC		1996

Accessory Dwelling Units

Index # - File Name: 1.0022 - Single Family Dwellings Data\_Snohomish County.pdf

New	Approved Basic #96-100376BP	Rambler Style SFR - 1994 UBC		1996
New	Approved Basic #96-101124BP	SFR w/unfinished basement - 1994 UBC		1996
New	Approved Basic #96-100816BP	SFR w/finished basement - 1994 UBC		1996
New		SFR w/finished basement - 1994 UBC		1996
New	Approved Basic #96-100373BP	Two Story SFR - 1994 UBC (Finaled bldg on 6-28-96. Notified R		1996
New		Rambler Style SFR - 1994 UBC		1996
New	Approved Basic #96-101124BP	SFR w/unfinished basement - 1994 UBC		1996
New	Approved Basic #96-100816BP	SFR w/finished basement - 1994 UBC		1996
New	Approved Basic #96-101124BP	SFR w/unfinished basement - 1994 UBC		1996
New	Approved Basic #96-101124BP	SFR w/unfinished basement - 1994 UBC		1996
New	Approved Basic #96-100376BP	Rambler Style SFR - 1994 UBC		1996
New	Approved Basic #96-101124BP	SFR w/unfinished basement - 1994 UBC		1996
New	Approved Basic #96-100816BP	SFR w/finished basement - 1994 UBC		1996
New	Approved Basic #96-101124BP	SFR w/unfinished basement - 1994 UBC		1996
New	Approved Basic #96-100816BP	SFR w/finished basement - 1994 UBC		1996
New	Approved Basic #96-100376BP	Rambler Style SFR - 1994 UBC		1996
New	Approved Basic #96-101124BP	SFR w/unfinished basement - 1994 UBC		1996
New	Approved Basic #96-100816BP	SFR w/finished basement - 1994 UBC		1996
New	Approved Basic #96-110241BP	Plan 1452 Rambler Style SFR - 1994 UBC		1996
New	Approved Basic #96-100816BP	SFR w/finished basement - 1994 UBC		1996
New	Approved Basic #96-101124BP	SFR w/unfinished basement - 1994 UBC		1996
New	Approved Basic #96-100816BP	SFR w/finished basement - 1994 UBC		1996
New	Approved Basic #96-107168BP	Rambler Style SFR - 1994 UBC		1996
New		Rambler Style SFR - 1994 UBC		1996
New		Two Story SFR - 1994 UBC		1996
New		Two Story SFR w/unfinished basement - 1994 UBC		1996
New		Rambler Style SFR - 1994 UBC		1996
New		Double Wide Mobile Home		1996
New		Single wide mobile home		1996
New		24x60 Rex 1969		1996
New		Two Story SFR w/unfinished basement - 1994 UBC		1996
New		2 story SFR with attached garage		1996
New		2 story SFR with attached garage		1996
New		2 Story with a 3 car		1996
New		40 x66 , 1997 Skyline Knollcrest		1996
New		SFR-Split w/ garage		1996
New		Space 59 - West View Estates Mobile Home Park		1996
New		SFR		1996
New		2 story duplex with attached garages		1996
New		2 story SFR, garage, covered porch, attic		1996
New	Approved Basic #95-109581-003BP	(Tulip) 0 lot line structure - 1994 UBC (Two Story)		1996
New	Approved Basic #95-109581-003BP	(Tulip) 0 lot line structure - 1994 UBC (Two Story)		1996
New	Approved Basic #96-103077BP	Rose Two Story SFR - 1994 UBC	0	1996
New	Approved Basic #96-103077BP	Rose Two Story SFR - 1994 UBC	0	1996
New	Approved Basic #95-109581-002BP	(Lily) 0 lot line structure - 1994 UBC (Two Story SFR)		1996
New	Approved Basic #95-109581-002BP	(Lily) 0 lot line structure - 1994 UBC (Two Story SFR)		1996
New	Approved Basic #96-103077BP	Rose Two Story SFR - 1994 UBC		1996

Accessory Dwelling Units

Index # - File Name: 1.0022 - Single Family Dwellings Data\_Snohomish County.pdf

New	Approved Basic #96-103077BP	Rose	Two Story SFR - 1994 UBC	1996
New	Approved Basic #95-109581-002BP	(Lily)	0 lot line structure - 1994 UBC (Two Story SFR)	1996
New	Approved Basic #95-109581-003BP	(Tulip)	0 lot line structure - 1994 UBC (Two Story)	1996
New	Approved Basic #95-109581-003BP	(Tulip)	0 lot line structure - 1994 UBC (Two Story)	1996
New	Approved Basic #95-109581-002BP	(Lily)	0 lot line structure - 1994 UBC (Two Story SFR)	1996
New	Approved Basic #96-103077BP	Rose	Two Story SFR - 1994 UBC	1996
New	Approved Basic #96-103077BP	Rose	Two Story SFR - 1994 UBC	1996
New	Approved Basic #96-105112BP	Deer Island	Rambler Style SFR - 1994 UBC	1996
New	Approved Basic #96-104404BP		Rambler Style SFR -1994 UBC	1996
New	Rambler with a 2 car			1996
New	Rambler with a 2 car			1996
New	28x44 (1996) Fleetwood #4443A			1996
New	Duplex			1996
New	Duplex			1996
New	27 x 56 Double Wide Mobile Home			1996
New	SFR w/ attached garage			1996
New	Double Wide mobile home			1996
New	Rambler with a 2 car			1996
New	SFR			1996
New	SFR, garage, deck, 1994 UBC			1996
New	1704-sf SFR w/attached Garage 552-sf.			1996
New	14x52, 1977 Kentwood			1996
New	SFR			1996
New	28 x 66 1996 Guerdon			1996
New	SFR			1996
New	Two Story SFR w/unfinished basement - 1994 UBC			1996
New	1995 27 x 66 Fleetwood			1996
New	Ref Lot 28 Permit #95-107706		2 story SFR w/Attached Garage	1996
New	1996 Palm Harbor			1996
New	1994 24 x 40 Redmond			1996
New	60 x36 Fleetwood Mobile Home			1996
New	2 Story with a 3 car garage			1996
New	Rambler with a 2 car			1996
New	Approved Basic #96-100716BP		Rambler Style SFR - 1994 UBC	1996
New	Approved Basic #96-106675BP		Two Story SFR - 1994 UBC	1996
New	Approved Basic #96-100763BP		Two Story SFR - 1994 UBC (2/3 car option)	1996
New	Approved Basic #95-109379BP		Two Story SFR - 1994 UBC	1996
New	2 Story with a 3 car			1996
New	2 Story SFR with attached garage			1996
New	2 Story with a 2 car			1996
New	Approved Basic #96-103802BP		Two Story SFR - 1994 UBC	1996
New	Approved Basic #95-110544BP		2 story SFR-2 or 3 car garage- 1994 UBC	1996
New	Approved Basic #96-107594BP		Two Story SFR - 1994 UBC	1996
New	Approved Basic #95-110544BP		2 story SFR-2 or 3 car garage- 1994 UBC	1996
New	2 story w/2 car			1996
New	Approved Basic #96-107271BP		Two Story SFR - 1994 UBC	1996
New	2 Story with a 3 car			1996

Accessory Dwelling Units

Index # - File Name: 1.0022 - Single Family Dwellings Data\_Snohomish County.pdf

New	2 Story with a 3 car		1996
New	Two Story SFR - 1994 UBC		1996
New	Approved Basic #96-107094BP	Two Story SFR - 1994 UBC	1996
New	Approved Basic #96-103439BP	Rambler with a 2 car	1996
New	Approved Basic #96-109846BP	Plan #2330D/3 Two Story SFR - 1994 UBC	1996
New	Approved Basic #96-100716BP	Rambler Style SFR - 1994 UBC	1996
New	Approved Basic #95-110547BP	Split- 2 car garage SFR- 1994 UBC	1996
New	Approved Basic #96-108502BP	SFR w/finished basement - 1994 UBC	1996
New	Approved Basic #96-108498BP	Plan #1813 Rambler Style SFR - 1994 UBC	1996
New	Approved Basic #96-107271BP	Two Story SFR - 1994 UBC	1996
New	Approved Basic #95-110544BP	2 story SFR-2 or 3 car garage- 1994 UBC	1996
New	Approved Basic #96-102650BP	Two Story SFR - 1994 UBC	1996
New	2 Story with a 3 car		1996
New	Approved Basic #96-109567BP	Two Story SFR - 1994 UBC	1996
New	Approved Basic #95-110544BP	2 story SFR-2 or 3 car garage- 1994 UBC	1996
New	Approved Basic #95-110544BP	2 story SFR-2 or 3 car garage- 1994 UBC	1996
New	Approved Basic #96-107094BP	Two Story SFR - 1994 UBC	1996
New	Approved Basic #96-106675BP	Two Story SFR - 1994 UBC	1996
New	Approved Basic #96-100716BP	Rambler Style SFR - 1994 UBC	1996
New	Approved Basic #95-110544BP	2 story SFR-2 or 3 car garage- 1994 UBC	1996
New	Two Story SFR - 1994 UBC		1996
New	2 Story Approved Basic #96-103802		1996
New	Two Story SFR - 1994 UBC		1996
New	Approved Basic #96-106675BP	Two Story SFR - 1994 UBC	1996
New	Rambler Style SFR - 1994 UBC		1996
New	1996 27 x 56 Goldenwest		1996
New	2 Story with a 2 car		1996
New	SFR		1996
New	Duplex		1996
New	Triple wide Mobile Home		1996
New	new SFR		1996
New	Approved Basic #96-105337BP	Two Story SFR - 1994 UBC	1996
New	Pending Basic #96-105337BP	Two Story SFR - 1994 UBC	1996
New	Approved Basic #96-108573BP	Two Story SFR - 1994 UBC	1996
New	Approved Basic #96-101623BP	Two Story SFR - 1994 UBC	1996
New	Approved Basic #96-101623BP	Two Story SFR - 1994 UBC	1996
New	Two Story SFR - 1994 UBC		1996
New	Two Story SFR - 1994 UBC		1996
New	Two Story SFR - 1994 UBC		1996
New	Two Story SFR - 1994 UBC		1996
New	2 story w/ 3 car		1996
New	2 story SFR with attached garage		1996
New	1984 14 x 60 Redman		1996
New	2 story SFR w/ 3 car garage- 1994 UBC		1996
New	new SFR		1996
New	2967 sq. ft 2-story w/ 810 sq. ft. attached garage		1996
New	Approved Basic #96-106627BP	Two Story SFR - 1994 UBC	1996

Accessory Dwelling Units

Index # - File Name: 1.0022 - Single Family Dwellings Data\_Snohomish County.pdf

New	Two Story SFR - 1994 UBC	Plan K2866X	1996
New	Approved Basic #96-101863BP	Two Story SFR - 1994 UBC	1996
New	Approved Basic #96-100583BP	Two Story SFR - 1994 UBC	1996
New	Approved Basic #96-105566BP	Two Story SFR - 1994 UBC	1996
New	Approved Basic #96-104451BP	Two Story SFR - 1994 UBC	1996
New	Approved Basic #96-104456BP	Two Story SFR - 1994 UBC	1996
New	Approved Basic #96-104459BP	Two Story SFR - 1994 UBC	1996
New	Approved Basic #96-101863BP	Two Story SFR - 1994 UBC	1996
New	Approved Basic #96-100583BP	Two Story SFR - 1994 UBC	1996
New	Approved Basic #96-101863BP	Two Story SFR - 1994 UBC	1996
New	Approved Basic #96-104451BP	Two Story SFR - 1994 UBC	1996
New	Two Story SFR - 1994 UBC		1996
New	Approved Basic #95-108142BP	SFR w/finished basement - 1994 UBC	1996
New	Approved Basic #95-108142BP	SFR w/finished basement - 1994 UBC (partial unfinished)	1996
New	Approved Basic #96-105561BP	Two Story SFR - 1994 UBC	1996
New	Approved Basic #96-104463BP	Plan #1732T Two Story SFR - 1994 UBC	1996
New	Approved Basic #96-104451BP	Two Story SFR - 1994 UBC	1996
New	SFR w/finished lower floor - 1994 UBC		1996
New	Approved Basic #96-105978BP	Two Story SFR - 1994 UBC	1996
New	Two Story SFR 1994 UBC		1996
New	Approved Basic #96-105978BP	Two Story SFR - 1994 UBC	1996
New	Approved Basic #96-105561BP	Two Story SFR - 1994 UBC	1996
New	Approved Basic #95-108142BP	SFR w/finished basement - 1994 UBC (partial unfinished)	1996
New	Approved Basic #95-108142BP	SFR w/finished basement - 1994 UBC (partial unfinished)	1996
New	Approved Basic #95-108142BP	SFR w/finished basement - 1994 UBC (partial unfinished)	1996
New	Approved Basic #95-108142BP	(**see note in process line regarding SFR w/finished bas	1996
New	Two Story SFR - 1994 UBC		1996
New	Approved Basic #96-101863BP	Two Story SFR - 1994 UBC	1996
New	Approved Basic #95-108142BP	SFR w/finished basement - 1994 UBC (partial unfinished)	1996
New	Approved Basic #96-104463BP	Two Story SFR - 1994 UBC	1996
New	Approved Basic #95-108142BP	SFR w/finished basement - 1994 UBC (partial unfinished)	1996
New	Approved Basic #96-104463BP	Two Story SFR - 1994 UBC	1996
New	Approved Basic #96-105385BP	Two Story SFR - 1994 UBC	1996
New	Approved Basic #96-104468BP	Two Story SFR - 1994 UBC	1996
New	Two Story SFR - 1994 UBC		1996
New	Rambler Style SFR - 1994 UBC	Plan 1735	1996
New	SFR w/unfinished basement - 1994 UBC	Plan 1500	1996
New	Tri-level SFR - 1994 UBC	Plan 1939	1996
New	new SFR		1996
New	Rambler Style SFR w/attached Garage		1996
New	Rambler style SFR w/attached Garage		1996
New	Rambler with a 2 car		1996
New	Rambler with a 3 car		1996
New	Approved Basic #96-102594BP	Rambler Style SFR - 1994 UBC	1996
New	Approved Basic #96-102594BP	Rambler Style SFR - 1994 UBC	1996
New	SFR w/unfinished basement - 1994 UBC		1996
New	Two Story SFR - 1994 UBC		1996

Accessory Dwelling Units

Index # - File Name: 1.0022 - Single Family Dwellings Data\_Snohomish County.pdf

New	1996	26 8 x 42 Marlett		1996
New		24 x 56 1977 Silvercrest		1996
New	Approved Basic #95-110380BP	SFR w/unfinished basement - 1994 UBC		1996
New	Approved Basic #95-110380BP	SFR w/unfinished basement - 1994 UBC		1996
New	Approved Basic #95-110380BP	SFR w/unfinished basement - 1994 UBC		1996
New		Rambler Style SFR - 1994 UBC		1996
New	Approved Basic #96-105640BP	SFR w/finished lower floor - 1994 UBC		1996
New	Approved Basic #96-101124BP	SFR w/unfinished basement - 1994 UBC		1996
New	Approved Basic #96-100373BP	SFR w/unfinished basement - 1994 UBC		1996
New	Approved Basic #96-101124BP	SFR w/unfinished basement - 1994 UBC		1996
New	Approved Basic #96-100599BP	Rambler Style SFR - 1994 UBC		1996
New	Approved Basic #96-100602BP	(Plan #1146) Rambler Style SFR - 1994 UBC		1996
New	Approved Basic #96-100603BP	(Plan #1544) SFR w/unfinished basement - 1994 UBC		1996
New	Approved Basic #96-100597BP	Two Story SFR - 1994 UBC		1996
New	Approved Basic #96-104161BP	Two Story SFR - 1994 UBC		1996
New	Approved Basic #96-100604BP	(Plan #1851) SFR w/unfinished basement - 1994		1996
New	Approved Basic #96-100603BP	(Plan #1544) SFR w/unfinished basement - 1994 UBC		1996
New	Approved Basic #96-100599BP	(Plan #1308) Rambler Style SFR - 1994 UBC		1996
New		2 story/2 car garage- 1994 UBC		1996
New	Approved Basic #96-100603BP	(Plan #1544) SFR w/unfinished basement - 1994 UBC		1996
New		SFR w/unfinished basement - 1994 UBC		1996
New		Split level with a 2 car		1996
New	Approved Basic #96-100373BP	SFR w/unfinished basement - 1994 UBC		1996
New	Approved Basic #96-100816BP	SFR w/finished basement - 1994 UBC		1996
New	Approved Basic #96-101124BP	SFR w/unfinished basement - 1994 UBC		1996
New	Approved Basic #96-100373BP	SFR w/unfinished basement - 1994 UBC		1996
New	Approved Basic #96-100816BP	SFR w/finished basement - 1994 UBC		1996
New	Approved Basic #96-105640BP	SFR w/finished lower floor - 1994 UBC		1996
New		Two Story SRF - 1994 UBC		1996
New	Approved Basic #96-100373BP	SFR w/unfinished basement - 1994 UBC		1996
New	Approved Basic #96-100816BP	SFR w/finished basement - 1994 UBC		1996
New	Approved Basic #96-101124BP	SFR w/unfinished basement - 1994 UBC		1996
New	Approved Basic #96-100373BP	SFR w/unfinished basement - 1994 UBC		1996
New		Two Story SFR - 1994 UBC		1996
New		Rambler w/2 car garage- 1994 UBC		1996
New	Approved Basic #96-100603BP	(Plan #1544) SFR w/unfinished basement - 1994 UBC		1996
New		Tri-level/3 car garage- 1994 UBC		1996
New	Approved Basic #96-100603BP	(Plan #1544) SFR w/unfinished basement - 1994 UBC		1996
New	Approved Basic #96-100604BP	(Plan #1851) SFR w/unfinished basement - 1994		1996
New	Approved Basic #96-100603BP	(Plan #1544) SFR w/unfinished basement - 1994 UBC		1996
New	Approved Basic #96-104161BP	(Plan #1390B (with bonus) Two Story SFR - 1994 UBC		1996
New	Approved Basic #96-100603BP	SFR w/unfinished basement - 1994 UBC		1996
New	Approved Basic #96-104161BP	(Plan #1390B (with bonus) Two Story SFR - 1994 UBC		1996
New	Approved Basic #96-104161BP	Two Story SFR - 1994 UBC		1996
New	Approved Basic #96-100604BP	(Plan #1851) SFR w/unfinished basement - 1994		1996
New	Approved Basic #95-108526BP	SFR w/unfinished basement 1994 UBC		1996
New	Approved Basic #95-108527BP	SFR w/unfinished basement 1994 UBC		1996

Accessory Dwelling Units

Index # - File Name: 1.0022 - Single Family Dwellings Data\_Snohomish County.pdf

New	Approved Basic #95-108526BP	SFR w/unfinished basement	1994 UBC	1996
New	Approved Basic #95-108526BP	SFR w/unfinished basement	1994 UBC	1996
New	Approved Basic #95-108527BP	SFR w/unfinished basement	1994 UBC	1996
New	Approved Basic #95-108526BP	SFR w/unfinished basement	1994 UBC	1996
New	Approved Basic #95-108527BP	SFR w/unfinished basement	1994 UBC	1996
New	Approved Basic #95-108526BP	SFR w/unfinished basement	1994 UBC	1996
New	Approved Basic #95-109256BP	Rambler Style SFR -	1994 UBC	1996
New	Approved Basic #95-108527BP	SFR w/unfinished basement	1994 UBC	1996
New	Approved Basic #95-108472BP	Rambler Style SFR -	1994 UBC	1996
New	Approved Basic #95-108472BP	Rambler Style SFR -	1994 UBC	1996
New	Approved Basic #95-108472BP	Rambler Style SFR -	1994 UBC	1996
New	Approved Basic #95-108472BP	Rambler Style SFR -	1994 UBC	1996
New	Approved Basic #95-108472BP	Rambler Style SFR -	1994 UBC	1996
New	Two Story SFR -		1994 UBC	1996
New	Two Story SFR -		1994 UBC	1996
New	Two Story SFR -		1994 UBC	1996
New	Two story SFR with 2-car garage			1996
New	Approved Basic 95-110571BP	Rambler Style SFR -	1994 UBC	1996
New	SFR Rambler/2 car garage-		1994 UBC	1996
New	Rambler with a 2 car			1996
New	Rambler with a 2 car			1996
New	SFR-		1994 UBC	1996
New	SFR-		1994 UBC	1996
New	sfr w/ basement, garage, deck			1996
New	2 story SFR w/ 2 car garage-		1994 UBC	1996
New	Approved Basic #96-100749BP	SFR w/finished basement -	1994 UBC	1996
New	Approved Basic 95-107925BP (Builders Plan #1740)	0 lot line structure	Two Story SFR -	1994 U
New	Approved Basic #96-100749BP	SFR w/finished basement -	1994 UBC	1996
New	Approved Basic #95-108149BP (0 lot line structure)	Two Story SFR -	1994 UBC	1996
New	Approved Basic #95-109658 (0 lot line structure)	SFR Rambler-	1994 UBC	1996
New	Approved Basic #96-100749BP	SFR w/finished basement -	1994 UBC	1996
New	Approved Basic #95-109658 (0 lot line structure)	SFR Rambler-	1994 UBC	1996
New	Approved Basic 95-107925BP (Builders Plan #1740)	0 lot line structure	Two Story SFR -	1994 U
New	Approved Basic #96-100749BP	SFR w/finished basement -	1994 UBC	1996
New	Approved Basic 95-107925BP (Builders Plan #1740)	0 lot line structure	Two Story SFR -	1994 U
New	Approved Basic 95-107925BP (Builders Plan #1740)	0 lot line structure	Two Story SFR -	1994 U
New	Approved Basic 95-107925BP (Builders Plan #1740)	0 lot line structure	Two Story SFR -	1994 U
New	Approved Basic #95-108149BP (0 lot line structure)	Two Story SFR -	1994 UBC	1996
New	Approved Basic 95-107925BP (Builders Plan #1740)	0 lot line structure	Two Story SFR -	1994 U
New	SFR w/finished basement -		1994 UBC	1996
New	Approved Basic #96-100749BP	SFR w/finished basement -	1994 UBC	1996
New	Approved Basic 95-107925BP (Builders Plan #1740)	0 lot line structure	Two Story SFR -	1994 U
New	Approved Basic #95-108149BP (0 lot line structure)	Plan #2043	Two Story SFR -	1994 UBC
New	24 X 52 Golden West			1971
New	Approved Basic #95-108527BP	SFR w/unfinished basement	1994 UBC	1996
New	Approved Basic #95-108472BP	Rambler Style SFR -	1994 UBC	1996
New	Approved Basic #95-108472BP	Rambler Style SFR -	1994 UBC	1996

Accessory Dwelling Units

Index # - File Name: 1.0022 - Single Family Dwellings Data\_Snohomish County.pdf

New	Approved Basic #95-108472BP	Rambler Style SFR - 1994 UBC	1996
New	Approved Basic #95-108472BP	Rambler Style SFR - 1994 UBC	1996
New	Approved Basic #95-108472BP	Rambler Style SFR - 1994 UBC	1996
New	Approved Basic #95-108472BP	Rambler Style SFR - 1994 UBC	1996
New	Approved Basic #95-108472BP	Rambler Style SFR - 1994 UBC	1996
New	Approved Basic #95-108527BP	SFR w/unfinished basement 1994 UBC	1996
New	Approved Basic #95-108526BP	SFR w/unfinished basement 1994 UBC	1996
New	Approved Basic #95-108527BP	SFR w/unfinished basement 1994 UBC	1996
New	Approved Basic #95-108527BP	SFR w/unfinished basement 1994 UBC	1996
New	Approved Basic #95-108527BP	SFR w/unfinished basement 1994 UBC	1996
New	Approved Basic #95-108526BP	SFR w/unfinished basement 1994 UBC	1996
New	Approved Basic #95-108527BP	SFR w/unfinished basement 1994 UBC	1996
New	SFR 1994-UBC		1996
New	2 story SFR		1996
New	1430 SF SFR with attached garage		1996
New	1996 28 x 49 Palm Harbor		1996
New	14 x 66 MH		1996
New	Duplex		1996
New	Duplex		1996
New	2 Story house		1996
New	Rambler w/ att. garage		1996
New	New SFR Rambler w/ garage		1996
New	Rambler with a 2 car		1996
New	Approved Basic #96-101057BP	SFR/split- 1994 UBC	1996
New	12 x 56 1972 Fleetwood		1996
New	Rambler with a 2 car		1996
New	Approved Basic #96-105888BP	Two Story SFR - 1994 UBC	1996
New	2 Story with a 2 car garage		1996
New	2 Story with a 2 car		1996
New	Approved Basic #96-100452BP	Two Story SFR - 1994 UBC	1996
New	Approved Basic #96-100375BP	Rambler Style SFR - 1994 UBC	1996
New	2 story SFR with attached garage		1996
New	Approved Basic #96-101277BP	Two Story SFR - 1994 UBC	1996
New	Approved Basic #95-109179BP	2 story sfr w/finished Basement- 1994 UBC	1996
New	Basic 96-101277BP	2 story SFR - 1994 UBC	1996
New	Approved Basic #96-101277BP	Two Story SFR - 1994 UBC	1996
New	Approved Basic #96-100452BP	Two Story SFR - 1994 UBC	1996
New	Approved Basic #96-101277BP	Two Story SFR - 1994 UBC	1996
New	Approved Basic #96-101277BP	Two Story SFR - 1994 UBC	1996
New	Approved Basic #96-101276BP	Two Story SFR - 1994 UBC	1996
New	Approved Basic #96-101277BP	Two Story SFR - 1994 UBC	1996
New	Approved Basic #96-100452BP	Two Story SFR - 1994 UBC	1996
New	Approved Basic #96-101276BP	Two Story SFR - 1994 UBC	1996
New	2 Story with a 3 car		1996
New	Approved Basic #96-106247BP	Two Story SFR - 1994 UBC	1996
New	Approved Basic #96-103500BP	Plan Cindy I SFR w/finished basement - 1994	1996
New	Approved Basic #96-102235BP	Split Level SFR - 1994 UBC	1996



Accessory Dwelling Units

Index # - File Name: 1.0022 - Single Family Dwellings Data\_Snohomish County.pdf

New	Rambler Style SFR - 1994 UBC		1996
New	Approved Basic #96-103500BP	Plan Cindy I SFR w/finished basement - 1994	1996
New	Approved Basic #96-102235BP	Split Level SFR - 1994 UBC	1996
New	Approved Basic #96-106247BP	Two Story SFR - 1994 UBC	1996
New	Approved Basic #96-102479BP	Tri-Level SFR w/unfinished lower floor - 1994 UBC	1996
New	Two Story SFR - 1994 UBC		1996
New	Approved Basic #96-102479BP	Tri-Level SFR w/unfinished lower floor - 1994 UBC	1996
New	Approved Basic #96-102479BP	Tri-Level SFR w/unfinished lower floor - 1994 UBC	1996
New	Approved Basic #96-102983BP	Two Story SFR - 1994 UBC	1996
New	2 story SFR w/ 2 car garage- 1994 UBC		1996
New	Approved Basic #96-103500BP	SFR w/finished basement - 1994 UBC	1996
New	Approved Basic #96-102475BP	Rambler Style SFR - 1994 UBC	1996
New	Approved Basic #96-102479BP	Tri-Level SFR w/unfinished lower floor - 1994 UBC	1996
New	Approved Basic #96-102475BP	Rambler Style SFR - 1994 UBC	1996
New	Approved Basic #96-102479BP	Tri-Level SFR w/unfinished lower floor - 1994 UBC	1996
New	Approved Basic #96-102235BP	Split Level SFR - 1994 UBC	1996
New	Approved Basic #96-103500BP	Plan Cindy I SFR w/finished basement - 1994	1996
New	Approved Basic #96-102475BP	Rambler Style SFR - 1994 UBC	1996
New	Two Story SFR - 1994 UBC		1996
New	Rambler Style SFR- 1994 UBC		1996
New	Approved Basic #95-109424	Split Entry SFR - 1994 UBC	1996
New	2 Story with a 3 car		1996
New	Approved Basic #95-109432BP	Two Story SFR with 2/3 car - 1994 UBC	1996
New	Approved Basic #96-103926BP	Two Story SFR - 1994 UBC	1996
New	Approved Basic #96-102235BP	Split Level SFR - 1994 UBC	1996
New	Approved Basic #96-102235BP	Split Level SFR - 1994 UBC	1996
New	Approved Basic #96-102475BP	Rambler Style SFR - 1994 UBC	1996
New	Approved Basic #96-102983BP	Two Story SFR - 1994 UBC	1996
New	Approved Basic #96-104718BP	SFR w/finished basement - 1994 UBC	1996
New	SFR w/unfinished basement - 1994 UBC		1996
New	Approved Basic #96-104718BP	SFR w/finished basement - 1994 UBC	1996
New	Approved Basic #96-104718BP	SFR w/finished basement - 1994 UBC	1996
New	Two Story SFR - 1994 UBC		1996
New	Approved Basic #96-100763BP	Two Story SFR - 1994 UBC (2/3 car option)	1996
New	Approved Basic #95-110547BP	Split- 2 car garage SFR- 1994 UBC	1996
New	Approved Basic #95-110547BP	Split- 2 car garage SFR- 1994 UBC	1996
New	Two Story SFR - 1994 UBC		1996
New	SFR w/unfinished basement - 1994 UBC		1996
New	Approved Basic #95-110544BP	2 story SFR-2 or 3 car garage- 1994 UBC	1996
New	Approved Basic #95-110544BP	2 story SFR-2 or 3 car garage- 1994 UBC	1996
New	Approved Basic #95-110544BP	2 story SFR-2 or 3 car garage- 1994 UBC	1996
New	Approved Basic #95-110544BP	2 story SFR-2 or 3 car garage- 1994 UBC	1996
New	Two Story SFR - 1994 UBC		1996
New	27 x 52 Marlette 1995		1996
New	96 Fleetwood		1996
New	new MH		1996
New	1996 40 x 66 WinterHaven by Golden West		1996

Accessory Dwelling Units

Index # - File Name: 1.0022 - Single Family Dwellings Data\_Snohomish County.pdf

New	1995 28 x 66 Marlett		1996
New	14x70 1978 Fleetwood Mobile		1996
New	2-Story SFR		1996
New	Approved Basic #96-102448BP Rambler Style SFR - 1994 UBC		1996
New	Approved Basic #96-102452BP SFR Rambler- 1994 UBC		1996
New	Approved Basic #95-109813BP SFR w/basement - 1994 UBC		1996
New	Rambler Style SFR - 1994 UBC		1996
New	1928 sq. ft. 2-story w/516 sq. ft. attached garage and 170 sq. ft. covered porch		1996
New	Double Wide Mobile Home		1996
New	Rambler Style SFR - 1994 UBC		1996
New	1993 14 x 66 Fleetwood		1996
New	Two Story SFR - 1994 UBC		1996
New	Daylite Rambler with a 2 car		1996
New	2 story w attached gargage w second story storage, covrd porches, unheated plant room		1996
New	Rambler no garage - 1994 UBC		1996
New	Two Story SFR - 1994 UBC		1996
New	Rambler w/ attached garage		1996
New	2 story duplex with attached garages		1996
New	2 Story no garage.		1996
New	28x66 Fleetwood - 1996		1996
New	1995 27 x 60 Greenhill		1996
New	Triple Wide Mobile		1996
New	Rambler with a 3 car		1996
New	Split level w/ 2 car		1996
New	SFR Rambler- 1994 UBC		1996
New	SFR Rambler- 1994 UBC		1996
New	SFR Rambler- 1994 UBC		1996
New	SFR Rambler- 1994 UBC		1996
New	Rambler Style SFR - 1994 UBC		1996
New	Rambler Style SFR - 1994 UBC		1996
New	Rambler Style SFR - 1994 UBC		1996
New	Rambler Style SFR - 1994 UBC		1996
New	SFR Rambler- 1994 UBC		1996
New	Rambler Style SFR - 1994 UBC		1996
New	Rambler Style SFR - 1994 UBC		1996
New	Rambler Style SFR - 1994 UBC		1996
New	Rambler Style SFR - 1994 UBC		1996
New	Rambler Style SFR - 1994 UBC		1996
New	Rambler Style SFR - 1994 UBC		1996
New	Two Story Duplex - 1994 UBC		1996
New	Two Story SFR - 1994 UBC	(0 lot line structure) Daffodil Plan	1996
New	Two Story SFR - 1994 UBC	(0 lot line structure) Tulip Plan	1996
New	Two Story SFR - 1994 UBC	(0 lot line structure) Daffodil Plan	1996
New	Two Story SFR - 1994 UBC	(0 lot line structure) Tulip Plan	1996
New	Two Story SFR - 1994 UBC	(0 lot line structure) Rose Plan	1996
New	Approved Basic #96-103077BP Two Story SFR - 1994 UBC		1996
New	Approved Basic #95-109581-002BP (Lily) 0 lot line structure - 1994 UBC (Two Story SFR)		1996
New	Approved Basic #95-109581-002BP (Lily) 0 lot line structure - 1994 UBC (Two Story SFR)		1996

Accessory Dwelling Units

Index # - File Name: 1.0022 - Single Family Dwellings Data\_Snohomish County.pdf

New	Approved Basic #95-109581-001BP (Orchid)	0 lot line structure - 1994 UBC (Two Story)	1996
New	Approved Basic #95-109581-002BP (Lily)	0 lot line structure - 1994 UBC (Two Story SFR)	1996
New	Two Story SFR - 1994 UBC	(0 lot line structure)	1996
New	Approved Basic #95-109581-002BP (Lily)	0 lot line structure - 1994 UBC (Two Story SFR)	1996
New	Approved Basic #95-109581-003BP (Tulip)	0 lot line structure - 1994 UBC (Two Story)	1996
New	Approved Basic #95-109581-002BP (Lily)	0 lot line structure - 1994 UBC (Two Story SFR)	1996
New	Two Story SFR - 1994 UBC	0 Lot Line Structure	1996
New	Two Story SFR - 1994 UBC	0 Lot Line Structure	1996
New	Approved Basic #96-103077BP	Two Story SFR - 1994 UBC	1996
New	Approved Basic #96-103077BP	Two Story SFR - 1994 UBC	1996
New	Approved Basic #95-109581-001BP (Orchid)	0 lot line structure - 1994 UBC (Two Story)	1996
New	Approved Basic #95-109581-003BP (Tulip)	0 lot line structure - 1994 UBC (Two Story)	1996
New	Approved Basic #95-109581-002BP (Lily)	0 lot line structure - 1994 UBC (Two Story SFR)	1996
New	Approved Basic #95-109581-003BP (Tulip)	0 lot line structure - 1994 UBC (Two Story)	1996
New	Approved Basic #95-109581-002BP (Lily)	0 lot line structure - 1994 UBC (Two Story SFR)	1996
New	Approved Basic #96-103077BP	Two Story SFR - 1994 UBC	1996
New	Approved Basic #96-103077BP	Rose Two Story SFR - 1994 UBC	1996
New	Approved Basic #95-109581-001BP (Orchid)	0 lot line structure - 1994 UBC (Two Story)	1996
New	Approved Basic #95-109581-003BP (Tulip)	0 lot line structure - 1994 UBC (Two Story)	1996
New	Approved Basic #95-109581-001BP (Orchid)	0 lot line structure - 1994 UBC (Two Story)	1996
New	Approved Basic #95-109581-001BP (Orchid)	0 lot line structure - 1994 UBC (Two Story)	1996
New	Rambler Style SFR - 1994 UBC		1996
New	Conversion Permit - Existing Temporary Dwelling to become permanent residence on Lot 2 of S1		1996
New	2 Bdrm SFR over garage 12/9/96	SPRINKLER SYSTEM FOR HOUSE SUBMITTED FOR PLAN CHECK	1996
New	28 X 60 American Mansion	1989	1996
New	1996	42 x 62 Palm Harbor	1996
New	SFR		1996
New	New SFR		1996
New	New SFR - Rambler w/ garage/carport		1996
New	Approved Basic #96-103379BP	0 Lot Line Structure Two Story SFR - 1994 UBC	1996
New	Approved Basic #96-103379BP	0 Lot Line Structure Two Story SFR - 1994 UBC	1996
New	Approved Basic #96-103409BP	0 Lot Line Structure Two Story SFR - 1994 UBC	1996
New	Approved Basic #96-103409BP	0 Lot Line Structure Two Story SFR - 1994 UBC	1996
New	Approved Basic #96-103379BP	0 Lot Line Structure Two Story SFR - 1994 UBC	1996
New	Approved Basic #96-103390BP	0 Lot Line Structure Two Story SFR - 1994 UBC	1996
New	Rambler Style SFR - 1994 UBC	0 Lot Line Structure	1996
New	Rambler Style SFR - 1994 UBC	0 Lot Line Structure	1996
New	Approved Basic #96-109140BP	Plan The Olympic Rambler Style SFR - 1994 UBC	1996
New	Approved Basic #96-109140BP	Plan Olympic Rambler Style SFR - 1994 UBC	1996
New	Approved Basic #96-103390BP	0 Lot Line Structure Two Story SFR - 1994 UBC	1996
New	Approved Basic #96-103409BP	0 Lot Line Structure Two Story SFR - 1994 UBC	1996
New	Approved Basic #96-103409BP	0 Lot Line Structure Two Story SFR - 1994 UBC	1996
New	Approved Basic #96-103390BP	0 Lot Line Structure Two Story SFR - 1994 UBC	1996
New	2 Story with a 3 car		1996
New	Approved Basic #95-110376BP	Rambler Style SFR - 1994 UBC	1996
New	Approved Basic #95-110380BP	SFR w/finished or unfinished basement - 1994 UBC	1996
New	Approved Basic #95-110380BP	SFR w/finished or unfinished basement - 1994 UBC	1996

Accessory Dwelling Units

Index # - File Name: 1.0022 - Single Family Dwellings Data\_Snohomish County.pdf

New	56 x 28 1996 Skyline	1996
New	SFR	1996
New	renewal of expired permits 270304 & 249299	1996
New	new SFR *** STOP WORK POSTED ON 03-10-97 BY M.MCCRARY ** M.McCrary stated: revise	1996
New	1996 Golden West Mobile Home	1996
New	2 Story with a basement and 2 car garage	1996
New	Rambler with a 2 car	1996
New	2 Story with a 2 car	1996
New	28 x 66 1990 Champion Sequoia	1996
New	2 Story with basement no garage	1996
New	SFR	1996
New	1996 Fleetwood 24 X 44	1996
New	2 story SFR- 1994 UBC	1996
New	2 story sfr	1996
New	Double Wide Mobile	1996
New	2 story SFR with attached garage	1996
New	14x70 1985 Champion Mobile Home. WORK WAS FINALED ON 5/25/03, 99-102832.	1996
New	SFR	1996
New	new SFR	1996
New	Mobile Home	1996
New	26 x 66 1984 Glen River	1996
New	2-Story SFR w/attached Garage	1996
New	Rambler with a 2 car	1996
New	27x48 Goldenwest	1996
New	27x48 Goldenwest	1996
New	Split Level with an unfinished basement & 2 car garage 9/27/96 - Blder changed from electric t	1996
New	9/27/96 - Blder changed from electric to LPG.	1996
New	Two Story SFR - 1994 UBC	1996
New	2 story SFR with attached garage	1996
New	Mobile Home	1996
New	24x60, 1976 Frontier	1996
New	28 X 64 Palm Harbor	1996
New	Approved Basic #95-109460BP Two Story Duplex - 1994 UBC	1996
New	Two Story SFR w/finished basement - 1994 UBC	1996
New	27 x 64 Palm Harbor	1996
New	Rambler w/Daylight Basement Change Size of LPG Tand to 500 Gal - 1/28/96	1996
New	Two Story SFR with Garage	1996
New	Approved Basic #95-109478BP Two Story SFR - 1994 UBC	1996
New	Approved Basic #95-109783BP Two Story SFR - 1994 UBC	1996
New	2418 sq. ft. 2-story w/736 sq. ft 3-car	1996
New	Approved Basic #96-106892BP Two Story SFR - 1994 UBC	1996
New	Approved Basic #96-101222BP Two Story SFR- 1994 UBC	1996
New	2 story SFR w/ 3 car garage- 1994 UBC	1996
New	2 story w/3 car	1996
New	Approved Basic #95-109787BP Two Story SFR - 1994 UBC	1996
New	1422 SF SFR with attached garage	1996
New	Duplex	1996

Accessory Dwelling Units

Index # - File Name: 1.0022 - Single Family Dwellings Data\_Snohomish County.pdf

New	Duplex		1996
New	new SFR		1996
New	Approved Basic #96-101623BP	Two Story SFR - 1994 UBC	1996
New	Two Story SFR- 1994 UBC		1996
New	Approved Basic #95-108142BP	SFR w/finished basement - 1994 UBC (partial unfinished)	1996
New	Approved Basic #95-108142BP	SFR w/finished basement - 1994 UBC (partial unfinished)	1996
New	Two Story SFR - 1994 UBC		1996
New	Approved Basic #95-109787BP	Two Story SFR - 1994 UBC	1996
New	Two Story SFR -1994 UBC		1996
New	2 Story w/3 car		1996
New	2 Story with a 3 car		1996
New	2-Story SFR w/attached garage.		1996
New	2 story SFR with attached garage		1996
New	Two Story SFR - 1994 UBC		1996
New	Approved Basic #95-110748BP	Rambler Style SFR - 1994 UBC	1996
New	2 Story SFR - 1994 UBC		1996
New	24x60 1981 Champion/Titan		1996
New	Westview Estates MH Park - Space 44		1996
New	44x24.8, 1996 Fleetwood MH		1996
New	Approved Basic #95-109101BP	Two Story SFR - 1994 UBC	1996
New	Approved Basic #95-109111BP	Two Story SFR - 1994 UBC	1996
New	Approved Basic #96-104225BP	SFR w/unfinished basement - (partially finished) 1994 UBC	1996
New	Approved Basic #96-104225BP	SFR w/unfinished basement - (partially finished) 1994 UBC	1996
New	Approved Basic #96-104759BP	Two Story SFR - 1994 UBC	Rosewood 1996
New	Approved Basic #96-104225BP	SFR w/unfinished basement - (partially finished) 1994 UBC	1996
New	Approved Basic #96-104759BP	Two Story SFR - 1994 UBC	Rosewood 1996
New	Approved Basic #95-109099	Rambler Style SFR - 1994 UBC	1996
New	Two Story SFR - 1994 UBC		1996
New	Approved Basic #95-109111BP	Two Story SFR - 1994 UBC	1996
New	Approved Basic #95-109102BP	Rambler Style SFR - 1994 UBC	1996
New	Approved Basic #95-109111BP	Two Story SFR - 1994 UBC	1996
New	Approved Basic #95-109111BP	Two Story SFR - 1994 UBC	1996
New	Approved Basic #96-104280BP	Two Story SFR - 1994 UBC	1996
New	Approved Basic #95-109101BP	Two Story SFR - 1994 UBC	1996
New	Two Story SFR - 1994 UBC		1996
New	Approved Basic #95-109101BP	Two Story SFR - 1994 UBC	1996
New	Approved Basic #95-109111BP	Two Story SFR - 1994 UBC	1996
New	Approved Basic #96-104280BP	Two Story SFR - 1994 UBC	1996
New	Approved Basic #95-109101BP	Two Story SFR - 1994 UBC	1996
New	Approved Basic #95-109102BP	Rambler Style SFR - 1994 UBC	1996
New	Approved Basic #95-109101BP	Two Story SFR - 1994 UBC	1996
New	Approved Basic #96-104228BP	SFR Rambler - 1994 UBC	1996
New	Approved Basic #95-109111BP	Two Story SFR - 1994 UBC	1996
New	Two Story SFR - 1994 UBC		1996
New	2 Story with a 2 car (*RSP submitted 8/4/96)		1996
New	Approved Basic #96-101411BP	Two Story SFR - 1994	(0 lot line structure) 1996
New	Approved Basic #96-101411BP	Two Story SFR - 1994	(0 lot line structure) 1996

Accessory Dwelling Units

Index # - File Name: 1.0022 - Single Family Dwellings Data\_Snohomish County.pdf

New	Approved Basic #96-101411BP	Two Story SFR - 1994	(0 lot line structure)	1996
New	Approved Basic #96-101411BP	Two Story SFR - 1994	(0 lot line structure)	1996
New	Approved Basic #96-107201BP	Two Story SFR - 1994 UBC	(0 lot line structure)	1996
New	Approved Basic #96-107201BP	Two Story SFR - 1994	(0 lot line structure)	1996
New	Approved Basic #96-101411BP	Two Story SFR - 1994	(0 lot line structure)	1996
New	Two Story SFR - 1994	(0 lot line structure)		1996
New	Two Story SFR - 1994 UBC	0 lot line structure		1996
New	Approved Basic #96-107201BP	0 Lot Line Structure	Two Story SFR - 1994 UBC	1996
New	Approved Basic #96-107201BP	0 Lot Line Structure	Two Story SFR - 1994 UBC	1996
New	Approved Basic #96-107201BP	0 Lot Line Structure	Two Story SFR - 1994 UBC	1996
New	Approved Basic #96-107201BP	0 Lot Line Structure	Two Story SFR - 1994 UBC	1996
New	Approved Basic #96-107201BP	0 Lot Line Structure	Two Story SFR - 1994 UBC	1996
New	Approved Basic #96-107201BP	0 Lot Line Structure	Two Story SFR - 1994 UBC	1996
New	Approved Basic #96-107201BP	0 Lot Line Structure	Two Story SFR - 1994 UBC	1996
New	SFR w/finished basement - 1994 UBC	(0 lot line structure)		1996
New	Approved Basic #96-101407BP	SFR w/finished basement - 1994 UBC	(0 lot line str	1996
New	Approved Basic #96-101407BP	SFR w/finished basement - 1994 UBC	(0 lot line str	1996
New	Approved Basic #96-101407BP	SFR w/finished basement - 1994 UBC	(0 lot line str	1996
New	SFR with Finished Basement and Garage			1996
New	Two Story SFR - 1994 UBC			1996
New	Two Story SFR - 1994 UBC			1996
New	SFR			1996
New	Rambler Style SFR - 1994 UBC			1996
New	4th Ave West Mobile Home Park			1996
New	2- Story Single Family Residence			1996
New	1996 40 x 62 Palm Harbor			1996
New	2 story w/ 2 car car			1996
New	SFR			1996
New	Approved Basic #96-104228BP	SFR Rambler - 1994 UBC		1996
New	Approved Basic #96-104754BP	Split Level SFR - 1994 UBC	Maple B	1996
New	Approved Basic #96-104225BP	SFR w/unfinished basement (partially finished)	1994 UBC	1996
New	Approved Basic #96-104225BP	SFR w/unfinished basement (partially finished)	- 1994 UBC	1996
New	Approved Basic #96-104754BP	Split Level SFR - 1994 UBC	Maple B	1996
New	Approved Basic #95-109102BP	Rambler Style SFR - 1994 UBC		1996
New	Approved Basic #95-109813BP	SFR w/basement - 1994 UBC		1996
New	Lot submitted 5-31-96			1996
New	Approved Basic #96-104962BP	Rambler Style SFR - 1994 UBC		1996
New	Approved Basic #96-104962BP	Rambler Style SFR - 1994 UBC		1996
New	Tri-Level SFR w/attached garage	STOP WORK ORDER POSTED 01/08/97- # s 1, 5, 7 & 8 permit c		1996
New	Split Leval with a 2 car			1996
New	Rambler with a 2 car			1996
New	2-Story SFR w/attached Garage			1996
New	2-Story SFR w/attached Garage			1996
New	26 X 66 Marlette Mobile Home			1996
New	2608-sf Rambler w/attached Garage/Shop			1996
New	2 Story with a 2 car			1996
New	48 x 24 Woodmanor			1996

Accessory Dwelling Units

Index # - File Name: 1.0022 - Single Family Dwellings Data\_Snohomish County.pdf

New	SFR		1996
New	Rambler Style SFR - 1994 UBC		1996
New	Two Story SFR - 1994 UBC		1996
New	Approved Basic #96-109405BP	Plan #2013 Split Level SFR w/finished c	1996
New	Approved Basic #96-110318BP	Plan 1428 Rambler Style SFR - 1994 U	1996
New	SFR w/unfinished basement - 1994 UBC		1996
New	Approved Basic #96-109405BP	Plan #2013 Split Level SFR w/finished c	1996
New	Approved Basic #96-109405BP	Plan #2013 Split Level SFR w/finished c	1996
New	SFR		1996
New	Approved Basic #96-110318BP	Plan 1428 Rambler Style SFR - 1994 U	1996
New	Approved Basic #96-110318BP	Plan 1428 Rambler Style SFR - 1994 U	1996
New	2 story SFR with attached garage		1996
New	2 story SFR with attached garage		1996
New	SFR		1996
New	28x40, 1991 Fleetwood		1996
New	Approved Basic #96-104984BP	Rambler Style SFR - 1994 UBC	1996
New	28 x 66 Mobile Home		1996
New	24x48, 1984 Rex MH		1996
New	1996 Golden West 40 X 60		1996
New	1996 28 x 52 Marlette		1996
New	Approved Basic #95-110376BP	Rambler Style SFR - 1994 UBC	1996
New	2-Story SFR w/attached Garage		1996
New	1987 Fleetwood double-wide		1996
New	28x56, 1996 Skyline MH		1996
New	Rambler w/ 2 car		1996
New	Rambler Style SFR - 1994 UBC		1996
New	42 x 66 Redmond		1996
New	Rambler w/unfin bsmt & 2 car		1996
New	SFR		1996
New	SFR		1996
New	Double Wide mobile		1996
New	Split level with a 2 car		1996
New	28 x 66 1996 Golden West		1996
New	1976 24 x 56 Fourseasons		1996
New	2 story SFR with attached garage		1996
New	Two Story SFR - 1994 UBC		1996
New	Two Story with attached Garage		1996
New	2 story SFR with attached garage and basement		1996
New	2 story w/bsmt & 3 car		1996
New	Approved Basic #96-105485BP	Rambler Style Duplex - 1994 UBC	1996
New	Approved Basic #96-105485BP	Rambler Style Duplex - 1994 UBC	1996
New	Approved Basic #96-105485BP	Rambler Style Duplex - 1994 UBC	1996
New	1996 27 x 56 Marlett		1996
New	3 Bedroom Rambler with attached garage		1996
New	52 x 28 1995 Marlette 9501		1996
New	2914 sq. ft. 2-story w/840 sq. ft. garage		1996
New	850 sq. ft 2nd floor living space w/816 sq. ft. 1st floor garage		1996

Accessory Dwelling Units

Index # - File Name: 1.0022 - Single Family Dwellings Data\_Snohomish County.pdf

New	1800sq.ft. 2-story w/ 453 sq. ft. garage	1996
New	28x44 (1996) Lake Pointe	1996
New	42 x 56 Duplex	1996
New	28X44, 1996 Value Series	1996
New	1952 sq. ft. rambler w/937 sq. ft. garage w/214 sq. ft. covered deck/porch	1996
New	Double Wide Mobile Home	1996
New	14 x 66 Liberty 1981	1996
New	1996 Silvercrest, 28 x 60 Mobile Home	1996
New	Approved Basic #95-109460BP Two Story Duplex - 1994 UBC	1996
New	28 x 48 1996 Fleetwood	1996
New	2452 SF duplex with attached garage	1996
New	14x60 Golden West 1996	1996
New	Approved Basic #96-102308BP Rambler Style SFR - 1994 UBC	1996
New	Approved Basic #95-1105768BP Rambler Style SFR - 1994 UBC	1996
New	Approved Basic 95-110571BP Rambler Style SFR - 1994 UBC	1996
New	Approved Basic #95-1105768BP Rambler Style SFR - 1994 UBC	1996
New	Approved Basic #95-1105768BP Rambler Style SFR - 1994 UBC	1996
New	Approved Basic #95-1105768BP Rambler Style SFR - 1994 UBC	1996
New	Approved Basic #95-1105768BP Rambler Style SFR - 1994 UBC	1996
New	Approved Basic #96-101189BP Two Story SFR - 1994 UBC	1996
New	Two Story SFR - 1994 UBC	1996
New	Two Story SFR - 1994 UBC	1996
New	Rambler Style SFR w/attached Garage	1996
New	2-Story SFR w/ attached Garage	1996
New	Approved Basic #96-100722BP Rambler Style SFR - 1994 UBC	1996
New	Approved Basic #95-1105768BP Rambler Style SFR - 1994 UBC	1996
New	Rambler w deck	1996
New	28 x 66 (1996) Wildsong	1996
New	1997 Silvercrest Manor (26 4 x66 )	1996
New	Triple Wide MH	1996
New	Approved Basic #95-106646BP Two Story SFR - 1994 UBC	1996
New	28 x 60 1996 Skyline	1996
New	SFR w/finished basement - 1994 UBC	1996
New	2-Story Duplex w/attached Garages	1996
New	1995 Ardmore 28 x 52 Mobile Home	1996
New	Approved Basic #95-108472BP Rambler Style SFR - 1994 UBC	1996
New		1996
New	SFR Rambler w/ garage	1996
New	1384 SF SFR with attached garage	1996
New	Approved Basic #96-105481BP Two Story Duplex - 1994 UBC	1996
New	28 x 56 Redman Mobile Home. (Permanent Residence on Site)	1996
New	14 x 66 1984 Liberty Oakbrook	1997
New	Rambler with attached garage and day-light basement - 1994 UBC	1997
New	1892 s.f. rambler with 2 car garage	1997
New	1624 sf SFR w/400 sf garage	1997
New	Approved Basic #95-1105768BP Rambler Style SFR - 1994 UBC	1997
New	27 x 66 1996 Skyline Spring Manor	1997



Accessory Dwelling Units

Index # - File Name: 1.0022 - Single Family Dwellings Data\_Snohomish County.pdf

New	28 x 42 1996 Palm Harbor		1997
New	1996-26 8 x 56 Fleetwood Mobile Home		1997
New	Two Story SFR - 1994 UBC (Finaled by N.Overland 12/9/97)		1997
New	4,061 sq. ft. rambler w/760 sq. ft. garage and 198 sq. ft covered porch		1997
New	2 story sfr with 2 car garage		1997
New	52 x 27 Double Wide Mobile Home		1997
New	Two Story SFR with Attached Garage		1997
New	576 sf Cabin		1997
New	Rambler Style SFR w/attached Garage.		1997
New	1820 sf tri-level with 430 sf garage		1997
New	2-Story SFR w/attached Garage		1997
New	SFR w/ attached garage		1997
New	2 Story w/ 3 car		1997
New	27 x 66 (1997) #1067 Madison		1997
New	24 x 38 1997 Fleetwood		1997
New	Rambler Style - SFR 1994 UBC Approved Basic 95-107973BP		1997
New	Approved Basic #96-109405BP	Plan #2013 Split Level SFR w/finished c	1997
New	Approved Basic #96-109405BP	Plan #2013 Split Level SFR w/finished c	1997
New	Approved Basic #96-110318BP	Plan 1428 Rambler Style SFR - 1994 U	1997
New	2884 sf rambler w/994 sf garage and 42 sf covered deck/porch		1997
New	2623 SF 2-STORY W/772 SF GARAGE		1997
New	2478 sf 2-story w/742 sf garage		1997
New	Approved Basic #97-103280BP	Plan #1400 SFR w/finished basement - 1994	1997
New	1303 sf SFR w/attached 440 sf garage		1997
New	Rambler style SFR w/attached garage.		1997
New	Approved Basic #97-100261BP	Plan #1827 B-3 Rambler Style SFR - 1994 UBC	1997
New	Two Story SFR - 1994 UBC		1997
New	Approved Basic #96-109996BP	Plan 3 Two Story SFR - 1994 UBC	1997
New	Two Story SFR - 1994 UBC	Plan #1	1997
New	Two Story SFR - 1994 UBC	Plan 5A	1997
New	Approved Basic #97-110400BP	Plan 1 Two Story SFR - 1994 UBC ***STOP W(	1997
New	Approved Basic #97-110400BP	Plan 1 Two Story SFR - 1994 UBC	1997
New	Approved Basic #97-110397BP	Plan 5A Two Story SFR - 1994 UBC	1997
New	Approved Basic #97-110400BP	Plan 1 Two Story SFR - 1994 UBC	1997
New	Approved Basic #97-110397BP	Plan 5A Two Story SFR - 1994 UBC	1997
New	Approved Basic #97-110397BP	Plan 5A Two Story SFR - 1994 UBC	1997
New	Approved Basic #96-109996BP	Plan 3 Two Story SFR - 1994 UBC	1997
New	SFR w/finished basement - 1994 UBC		1997
New	Approved Basic #97-100585BP	Plan #Alder II Tri-Level SFR - 1994 UBC	1997
New	Approved Basic #97-100585BP	Plan - Alder II - Tri-Level SFR w/finished basement -	1997
New	Approved Basic #96-107054BP	Plan Spruce SFR w/finished basement - 1994 U	1997
New	Approved Basic #97-100585BP	Plan #Alder II Tri-Level SFR - 1994 UBC	1997
New	2 story sfr with 3 car garage		1997
New	2 story w/ 2 car		1997
New	Approved Basic #95-108882BP	Plan #1315 SFR/w basement - 1994 UBC	1997
New	2 Story w/3 car 2. Lat. Engrd by John P. Vardanega PE #29736		1997
New	Approved Basic #97-100585BP	Plan Alder II-Tri-Level SFR w/finished basement -	1997

Accessory Dwelling Units

Index # - File Name: 1.0022 - Single Family Dwellings Data\_Snohomish County.pdf

New	Approved Basic #96-104754BP	Split Level SFR - 1994 UBC	Maple B	1997
New	Approved Basic #96-109996BP	Plan 3	Two Story SFR - 1994 UBC	1997
New	Rambler with daylighted and attached garage - 1994 UBC			1997
New	Two Story SFR w/unfinished basement - 1994 UBC			1997
New	Two-story SFR w/unfin bsmt - 1994 UBC			1997
New	2-Story SFR w/attached Garage			1997
New	SFR			1997
New	3523 sf 2-story w/979 sf garage and 69 sf covered deck/porch			1997
New	2 story sfr with 3 car garage			1997
New	Two Story SFR - 1994 UBC			1997
New	2 story with daylighted and attached garage - 1994 UBC			1997
New	2-Story SFR w/attached 3-car Garage			1997
New	2 Story w/ 3 car			1997
New	3670 sf 2-Story w/attached 992 sf Garage			1997
New	Approved Basic #95-109478BP	Two Story SFR - 1994 UBC		1997
New	Rambler w/3 car			1997
New	Approved Basic #95-109783BP	Two Story SFR - 1994 UBC		1997
New	Approved Basic #95-109272BP	Two Story SFR - 1994 UBC		1997
New	Approved Basic #95-109481BP	(3/4 car option approved)	Two Story SFR - 1994 UBC	1997
New	3420 sf 2-story w/736 sf garage and 86 sf covered deck/porch			1997
New	Approved Basic 97-103738 BP	Plan #2084 A/3	Two Story SFR - 1994 UBC	1997
New	Approved Basic #97-103738	Two Story SFR - 1994 UBC		1997
New	Approved Basic #97-103738BP	Two Story SFR - 1994 UBC	Pending Basic #97-103738 BP	1997
New	Approved Basic #97-103704BP	Plan #1755	Two Story SFR - 1994 UBC	1997
New	Approved Basic #96-109405BP	Plan #2013	Split Level SFR w/finished c	1997
New	Approved Basic #97-103738BP	Plan #2084 A/3	Two Story SFR - 1994 UBC C	1997
New	Approved Basic #97-103738BP	Plan #2084 A/3	Two Story SFR - 1994 UBC C	1997
New	Approved Basic #97-105888BP	Plan #1500	SFR w/unfinished lower floor - 1	1997
New	Approved Basic #97-105888BP	Plan #1500	SFR w/unfinished lower floor - 1	1997
New	Approved Basic #97-100387BP	Plan 1939	SFR w/finished basement - 199	1997
New	Approved Basic #97-100387BP	Plan 1939	SFR w/finished basement - 199	1997
New	Approved Basic #95-109481BP	(3/4 car option approved)	Two Story SFR - 1994 UBC	1997
New	Approved Basic #95-109478BP	Two Story SFR - 1994 UBC		1997
New	Approved Basic #95-108665BP	Two Story SFR - 1994 UBC		1997
New	Two Story SFR - 1994 UBC			1997
New	Two Story SFR - 1994 UBC			1997
New	Two Story SFR w/finished basement - 1994 UBC			1997
New	Approved Basic #96-105561BP	Plan 2025-T-3	Two Story SFR - 1994 UBC	1997
New	Approved Basic #97-102217BP	Plan 2150-T	SFR w/finished lower floor - 1994 UBC	1997
New	Approved Basic #96-101863BP	Plan 1927-3	Two Story SFR - 1994 UBC	1997
New	Approved Basic #96-100583BP	Plan #1905-3	Two Story SFR - 1994 UBC	1997
New	Two Story SFR - 1994 UBC	Plan #1865-3		1997
New	Approved Basic #96-104459BP	Plan #1800	Two Story SFR - 1994 UBC (Finaled I	1997
New	Approved Basic #96-104459BP	Plan #1800	Two Story SFR - 1994 UBC	1997
New	Approved Basic #95-108142BP	Plan 2195-2	SFR w/finished basement - 1994	1997
New	Approved Basic #95-108142BP	Plan 2195-2	SFR w/finished basement - 1994	1997
New	Approved Basic #97-103212BP	Plan #1A	SFR w/finished basement - 1994	1997

Accessory Dwelling Units

Index # - File Name: 1.0022 - Single Family Dwellings Data\_Snohomish County.pdf

New	Approved Basic #97-102632BP	Plan #Elmwood 2	SFR w/finished lower fl	1997
New	SFR w/finished basement - 1994 UBC	Plan #2220S/2-3	(Reinspection fee due as of i	1997
New	SFR w/finished lower floor - 1994 UBC	Plan #Elmwood		1997
New	Approved Basic #95-108142BP	Plan 2195-2	SFR w/finished basement - 1994	1997
New	Approved Basic #97-102632BP	Plan # Elmwood 2	Two Story SFR - 1994 UBC	1997
New	SFR w/finished lower floor - 1994 UBC	Plan 1#A		1997
New	Approved Basic #95-108142BP	Plan 2195-2	SFR w/finished basement - 1994	1997
New	Approved Basic #95-108142BP	Plan 2195-2	SFR w/finished basement - 1994	1997
New	Split w 3 car-SFR			1997
New	Two Story SFR - 1994 UBC			1997
New	1500-sf SFR			1997
New	Two Story SFR - 1994 UBC	Plan #3743		1997
New	28 x 64 (1997) Northwest Limited			1997
New	2-Story SFR w/attached garage.			1997
New	Rambler style SFR, w/attached garage			1997
New	9/17/97 applicant changed to Propane plus 3 gas piping connections.			1997
New	2 story sfr with 2 car garge			1997
New	One-story SFR w/unfin bsmt & attached garage			1997
New	Tri-Level with 3 car garage			1997
New	Rambler Style SFR w/attached garage.			1997
New	Daylite Rambler with a 2 car	3-18-97	Applicant brought in approved set of contractor s plans fr	1997
New	Rambler Style SFR - 1994 UBC	3/4/97	- RSP submitted - OK d by MM & Health Dist. 3/17/97.	1997
New	Rambler Style SFR - 1994 UBC			1997
New	Rambler Style SFR - 1994 UBC			1997
New	Rambler Style SFR - 1994 UBC			1997
New	Rambler Style SFR - 1994 UBC			1997
New	Rambler Style SFR - 1994 UBC			1997
New	Rambler Style SFR - 1994 UBC			1997
New	Rambler Style SFR - 1994 UBC			1997
New	14 x 70 - 1980 - Fleetwood .			1997
New	Two-story SFR w/attached garage			1997
New	SFR with daylight and attached garage - 1994 UBC			1997
New	Two Story SFR - 1994 UBC			1997
New	Two Story SFR - 1994 UBC			1997
New	Rambler with attached Garage			1997
New	One-story SFR w/attached garage			1997
New	Approved Basic #97-109349BP	Builders Plan 1785	Rambler style SFR w/attac	1997
New	Two Story SFR - 1994 UBC	Plan 1721		1997
New	2 Story w/2 car			1997
New	Rambler style SFR with unfinished daylight basement and attached garage			1997
New	2-Story SFR w/attached Garage			1997
New	2 story sfr			1997
New	Approved Basic #95-108149BP (0 lot line structure)	Plan #2043	Two Story SFR - 1994 UBC	1997
New	Approved Basic 95-107925BP (Builders Plan #1740) 0 lot line stucture		Two Story SFR - 1994 U	1997
New	Approved Basic 95-107925BP (Builders Plan #1740) 0 lot line stucture		Two Story SFR - 1994 U	1997
New	Approved Basic 95-107925BP (Builders Plan #1740) 0 lot line stucture		Two Story SFR - 1994 U	1997

Accessory Dwelling Units

Index # - File Name: 1.0022 - Single Family Dwellings Data\_Snohomish County.pdf

New	Approved Basic #95-108149BP	(0 lot line structure)	Plan #2043	Two Story SFR - 1994 UBC	1997
New	Approved Basic #95-108149BP	(0 lot line structure)	Plan #2043	Two Story SFR - 1994 UBC	1997
New	Approved Basic #95-109658	(0 lot line structure)	SFR Rambler-	1994 UBC	1997
New	2619 sf 2-story w/1789 sf unfinished basement and 780 sf garage				1997
New	Daylight Basement SFR w/attached Garage & Hanger.				1997
New	2-Story SFR w/attached garage.				1997
New	Approved Basic #96-104557BP	Rambler Style SFR - 1994 UBC			1997
New	2381 sf Cedar Home with 1784sf comprising the Main Floor and 597sf comprising the finished				1997
New	Approved Basic #97-110018BP		Plan #1641	Rambler Style SFR - 1994 UBC	1997
New	Approved Basic #96-103463BP	Rambler Style SFR - 1994 UBC			1997
New	Rambler style with attached garage - 1994 UBC				1997
New	1719 sf 2-story w/469 sf garage and 200 sf covered deck/porch				1997
New	Approved Basic #96-104557BP	Rambler Style SFR - 1994 UBC			1997
New	Rambler with attached garage - 1994 UBC				1997
New	2 story sfr with 2 car garage				1997
New	1936 sf 2-story w/525 sf garage and 395 sf covered deck/porch + plus 410 sf Bonus room				1997
New	SFR w/finished basement - 1994 UBC				1997
New	Approved Basic #97-100387BP		Plan 1939	SFR w/finished basement - 1994 UBC	1997
New	Approved Basic #97-102472BP	Two Story SFR - 1994 UBC		Plan #K2705X	1997
New	Approved Basic #96-103338BP		Plan #2645 A/B	Two Story SFR -1994 UBC	1997
New	Two-story SFR w/attached garage				1997
New	Approved Basic # 97-109784-BP		Plan 2563 C13	Two-story SFR w/3-car garage	1997
New	Two Story SFR - 1994 UBC		Plan #2563 C/3		1997
New	Two Story SFR - 1994 UBC		Plan #2506 C/3		1997
New	Two Story SFR - 1994 UBC		Plan #2605 A/3		1997
New	2 story SFR w/ garage				1997
New	Rambler with attached garage - 1994 UBC				1997
New	Approved Basic #97-103280BP		Plan #1400	SFR w/finished basement - 1994 UBC	1997
New	1795 sf 2-Story SFR with 620 sf attached garage - 1994 UBC				1997
New	Approved Basic #96-102650BP	Two Story SFR - 1994 UBC			1997
New	Approved Basic #97-103280BP		Plan #1400	SFR w/finished basement - 1994 UBC	1997
New	Unfinished Daylight Basement - SFR w/attached Garage				1997
New	Approved Basic #97-100672BP		Plan #1437	Rambler Style SFR - 1994 UBC	1997
New	Approved Basic #97-100672BP		Plan #1437	Rambler Style SFR - 1994 UBC	1997
New	Approved Basic #97-100672BP		Plan #1437	Rambler Style SFR - 1994 UBC	1997
New	2315 sf 2-story w/720 sf garage and 30 sf covered deck/porch				1997
New	Approved Basic #96-109567BP	Two Story SFR - 1994 UBC			1997
New	Approved Basic #96-107271BP	Two Story SFR - 1994 UBC			1997
New	Approved Basic #97-104957BP	Two Story SFR - 1994 UBC			1997
New	Approved Basic #96-106675BP	Two Story SFR - 1994 UBC			1997
New	2174 sf 2-Story SFR with 680 sf attached garage - 1994 UBC				1997
New	Approved Basic #97-100235BP		Plan Name- Bristol - Elv. E	Two Story SFR - 1994 UBC	1997
New	Approved Basic #96-109567BP	Two Story SFR - 1994 UBC			1997
New	Rambler Style SFR - 1994 UBC		Plan #1841		1997
New	Approved Basic #96-103802BP	Two Story SFR - 1994 UBC			1997
New	Approved Basic #96-100716BP	Option Approved - 3 car garage		Rambler Style SFR - 1994 UBC	1997
New	2 story with attached garage				1997

Accessory Dwelling Units

Index # - File Name: 1.0022 - Single Family Dwellings Data\_Snohomish County.pdf

New	Rambler style Duplex w/attached garages.		1997
New	SFR		1997
New	Approved Basic #97-104573BP	Plan #1020 Two Story SFR - 1994 UBC	1997
New	2 story SFR with attached garage		1997
New	26x54 (1986) Fuqua Revised 5/14/97 - MH to be 27 x 66 Palm Harbor		1997
New	Two Story SFR - 1994 UBC		1997
New	60x24 (1994) Everlast		1997
New	Approved Basic #96-104613BP	Two Story SFR - 1994 UBC	1997
New	Approved Basic #96-104181BP	Two Story SFR - 1994 UBC	1997
New	Rambler with Attached Garage		1997
New	1864 sf rambler w/576 sf garage and 175 sf covered deck/porch plus 420 sf bonus room		1997
New	Approved Basic #96-104185BP	Two Story SFR w/finished basement - 1994 UBC	1997
New	Approved Basic #96-104185BP	Two Story SFR w/finished basement - 1994 UBC	1997
New	Approved Basic #96-106945BP	Two Story SFR - 1994 UBC	1997
New	2 story Log House		1997
New	2-Story SFR w/daylight Basement & attached Garage		1997
New	2100 sf rambler w/500 sf garage		1997
New	1997, 40x64 Redman		1997
New	Rambler Style SFR w/attached Garage.		1997
New	Two Story SFR w/unfinished basement - 1994 UBC		1997
New	2 story w/ 2 car		1997
New	1320 sf Rambler with 452 sf garage		1997
New	Approved Basic #96-109445BP	Plan #1715 Two Story SFR - 1994 UBC	1997
New	Approved Basic #96-109445BP	Plan #1715 Two Story SFR - 1994 UBC	1997
New	Approved Basic #96-101277BP	Plan 1732 Two Story SFR - 1994 UBC	1997
New	Approved Basic #96-100375BP	Plan #1502 Rambler Style SFR - 1994 UBC	1997
New	Approved Basic #96-101276BP	Plan 2005 Two Story SFR - 1994 UBC	1997
New	Approved Basic #96-109445BP	Plan #1715 Two Story SFR - 1994 UBC	1997
New	Approved Basic #96-101277BP	Plan 1732 Two Story SFR - 1994 UBC	1997
New	Approved Basic #95-109179BP	2 story sfr w/finished Basement- 1994 UBC	1997
New	Approved Basic #96-100452BP	Plan 1930 Two Story SFR - 1994 UBC	1997
New	Approved Basic #96-101276BP	Plan 2005 Two Story SFR - 1994 UBC	1997
New	Approved Basic #96-100375BP	Rambler Style SFR - 1994 UBC	1997
New	Approved Basic #96-109445BP	Plan #1715 Two Story SFR - 1994 UBC	1997
New	Approved Basic #96-109445BP	Plan #1715 Two Story SFR - 1994 UBC	1997
New	Approved Basic #96-101277BP	Plan 1732 Two Story SFR - 1994 UBC	1997
New	Two Story SFR with finished Basement - 1994 UBC		1997
New	Two-story SFR w/attached garage		1997
New	2 story sfr with 3 car garage.		1997
New	2 story sfr with 3 car garage		1997
New	Two Story SFR with Attached Garage		1997
New	SFR w/ attached garage		1997
New	Two Story SFR - 1994 UBC		1997
New	2-Story SFR w/attached garage.		1997
New	2-Story SFR w/attached garage		1997
New	2 story with 3 car garage		1997
New	2 story sfr with unfinished basement and 3 car garage		1997

Accessory Dwelling Units

Index # - File Name: 1.0022 - Single Family Dwellings Data\_Snohomish County.pdf

New	Two Story SFR with Attached Garage		1997
New	One-story SFR w/basement & garage		1997
New	2630 s.f. rambler with 860 - 3 car garage		1997
New	One-story SFR w/basement & attached garage		1997
New	2-Story SFR w/attached garage		1997
New	2630 s.f. rambler with 860 s.f. 3 car garage		1997
New	2137 sf 2-story with 638 sf garage and 85 sf covered deck/porch		1997
New	2 story SFR with attached garage		1997
New	1816 sf 2-story w/480 sf garage		1997
New	Two-story SFR w/attached garage		1997
New	2-Story SFR w/attached garage		1997
New	2 story sfr with 3 car garage		1997
New	2 story SFR with attached garage		1997
New	2088 sf 2-story w/794 sf garage		1997
New	2 story SFR with attached garage		1997
New	2 story with 3 car garage		1997
New	24x60 (1981) Fleetwood		1997
New	24x60 (1978) Sheltertex		1997
New	Two story SFR w/attached garage		1997
New	Approved Basic #96-109445BP	Plan #1715 Two Story SFR - 1994 UBC	1997
New	Approved Basic #96-101277BP	Plan 1732 Two Story SFR - 1994 UBC	1997
New	Approved Basic #96-109445BP	Plan #1715 Two Story SFR - 1994 UBC	1997
New	Approved Basic #96-101276BP	Plan 2005 Two Story SFR - 1994 UBC	1997
New	Approved Basic #96-100452BP	Plan 1930 Two Story SFR - 1994 UBC	1997
New	Approved Basic #96-101277BP	Plan 1732 Two Story SFR - 1994 UBC	1997
New	Approved Basic #96-100452BP	Plan 1930 Two Story SFR - 1994 UBC	1997
New	Approved Basic #96-101276BP	Plan 2005 Two Story SFR - 1994 UBC	1997
New	Approved Basic #96-109445BP	Plan #1715 Two Story SFR - 1994 UBC	1997
New	Approved Basic #96-101277BP	Plan 1732 Two Story SFR - 1994 UBC	1997
New	Approved Basic #96-109445BP	Plan #1715 Two Story SFR - 1994 UBC	1997
New	Approved Basic #96-100452BP	Plan 1930 Two Story SFR - 1994 UBC	1997
New	Approved Basic #96-101276BP	Plan 2005 Two Story SFR - 1994 UBC	1997
New	Approved Basic #96-101277BP	Plan 1732 Two Story SFR - 1994 UBC	1997
New	Rambler style SFR w/attached Garage.		1997
New	2 story sfr with 2 car garage		1997
New	2 story sfr with 3 car garage		1997
New	Rambler Style SFR - 1994 UBC		1997
New	Single Story SFR - 1994 UBC		1997
New	Rambler Style with basement and attached garage. (Finaled by D.Erichsen 12/9/97)		1997
New	Rambler style SFR w/attached Garage		1997
New	Rambler Style SFR - 1994 UBC		1997
New	Approved Basic #97-100672BP	Plan #1437 Rambler Style SFR - 1994 UB	1997
New	Approved Basic #96-110601BP	Plan 1514 Two Story SFR - 1994 UBC	1997
New	Approved Basic #96-110601BP	Plan 1514 Two Story SFR - 1994 UBC	1997
New	SFR w/finished basement - 1994 UBC		1997
New	2-Story SFR w/unfin Daylight Basement & attached garage.		1997
New	3161 sf 2-story w/926 sf garage		1997

Accessory Dwelling Units

Index # - File Name: 1.0022 - Single Family Dwellings Data\_Snohomish County.pdf

New	SW Mobile Home. Will be converted to Temp DU during SFR construction when SFR permit taken		1997
New	Two Story SFR with Attached Garage		1997
New	2842 sq. ft. 2-story w/752 sq. ft. garage and 258 sq. ft. covered deck/porch		1997
New	Approved Basic #96-105337BP	Two Story SFR - 1994 UBC	1997
New	Two-story SFR w/attached garage		1997
New	1248 sf SFR with 624 attached garage		1997
New	1952 sf 2-story w/520 sf garage and 102 sf covered deck/porch		1997
New	Daylight Basement SFR - 1994 UBC		1997
New	SFR		1997
New	Approved Basic #97-100849 BP	Plan # D042093 2-Story SFR - 1994 UBC	1997
New	Approved Basic #97-100599BP	Plan #E-050492 Two Story SFR - 1994 UBC	1997
New	Approved Basic #97-100849 BP	Plan # D042093 2-Story SFR - 1994 UBC	1997
New	Two Story SFR - 1994 UBC	Plan: #1700T	1997
New	Rambler Style SFR - 1994 UBC	Plan: 1600 R/2	1997
New	1839 sf 2-story w/704 sf garage and 28 sf covered deck/porch		1997
New	2-Story SFR w/attached Garage		1997
New	Two Story SFR - 1994 UBC		1997
New	2-Story SFR w/attached Garage		1997
New	Approved Basic #97-100603BP	Plan #C 091888 Two Story SFR - 1994 UBC	1997
New	1900 sf SFR with 768 sf attached garage - 1994 UBC		1997
New	Approved Basic #96-109905BP	Plan 1917 Two Story SFR - 1994 UBC	1997
New	Approved Basic #96-109132BP	Plan #2154 Two Story SFR - 1994 UBC	1997
New	2060 sf 2-story w/ 528 sf garage		1997
New	Approved Basic #95-110105BP	Two Story SFR - 1994 UBC	1997
New	Approved Basic #96-109288BP	Two Story SFR - 1994 UBC	Plan 1887 -2/3
New	Approved Basic #96-109905BP	Plan 1917 Two Story SFR - 1994 UBC	1997
New	Approved Basic #96-110564BP	Rambler Style SFR - 1994 UBC	Plan 1825
New	Approved Basic #96-109132BP	Plan #2154 Two Story SFR - 1994 UBC	1997
New	Two Story SFR - 1994 UBC	Plan #2302	1997
New	2-Story SFR w/attached Garage.		1997
New	2 story w/1152 sf garage		1997
New	2 story w/bsmt & 3 car		1997
New	Approved Basic #96-110592BP	Plan #9302 (front entrance garage) Two Story SFR -	1997
New	Two Story SFR - 1994 UBC		1997
New	Rambler w/4 car		1997
New	Rambler with attached garage		1997
New	Approved Basic #97-100801BP	Plan #2064 Two Story SFR - 1994 UBC	1997
New	Approved Basic #97-105350BP	Plan #2210 Two Story SFR - 1994 UBC	1997
New	Approved Basic #96-110592BP	Plan #9302 Two Story SFR - 1994 UBC	1997
New	Approved Basic #97-103094BP	Plan #9310-1 Two Story SFR - 1994 UBC	1997
New	Approved Basic #96-100763BP	Two Story SFR - 1994 UBC (2/3 car option)	1997
New	Approved Basic #97-103713BP	Rambler Style SFR - 1994 UBC	Plan 1839
New	Approved Basic #96-110564BP	Rambler Style SFR - 1994 UBC	Plan 1825
New	Approved Basic #95-110547BP	Split- 2 car garage SFR- 1994 UBC	1997
New	Approved Basic #95-110832BP	Plan #1939 Rambler Style SFR - 1994 UBC	1997
New	Approved Basic #95-108142BP	Plan 2195-2 SFR w/finished basement - 1994	1997
New	Approved Basic #97-100801BP	Plan #2064 Two Story SFR - 1994 UBC	1997

Accessory Dwelling Units

Index # - File Name: 1.0022 - Single Family Dwellings Data\_Snohomish County.pdf

New	Approved Basic #95-108142BP	Plan 2195-2 SFR w/finished basement - 1994	1997
New	Rambler Style SFR - 1994 UBC		1997
New	Rambler Style SFR - 1994 UBC	Plan 1839	1997
New	Approved Basic #97-100801BP	Plan #2064 Two Story SFR - 1994 UBC	1997
New	Approved Basic #95-110547BP	Plan: #1998 Split Level SFR - 1994 UBC	1997
New	Approved Basic #97-100801BP	Plan #2064 Two Story SFR - 1994 UBC	1997
New	2-Story SFR w/attached garage		1997
New	Approved Basic #96-109132BP	Plan #2154 Two Story SFR - 1994 UBC	1997
New	Approved Basic #95-110544BP	Plan: 2137 2/3 2 story SFR-2 or 3 car garage- 1994	1997
New	Approved Basic #97-105350BP	Plan #2210 Two Story SFR - 1994 UBC	1997
New	Approved Basic #96-100583BP	Plan #1905-3 Two Story SFR - 1994 UBC	1997
New	Approved Basic #95-110547BP	Plan 1998 Split- 2 car garage SFR- 1994 UBC	1997
New	Approved Basic #95-110547BP	Plan 1998 Split- 2 car garage SFR- 1994 UBC	1997
New	Approved Basic #96-109289BP	Two Story SFR - 1994 UBC	Plan #1887-S 1997
New	Approved Basic #97-105350BP	Plan #2210 Two Story SFR - 1994 UBC	1997
New	Approved Basic #97-106045BP	Plan #1887 Two Story SFR - 1994 UBC (Finaled by	1997
New	Approved Basic #97-105350BP	Plan #2210 Two Story SFR - 1994 UBC	1997
New	One Story SFR with attached Garage	12/30/96, talked to Joe Hattendord about requirement or	1997
New	Approved Basic #96-110590BP	Plan 1887-S Two Story SFR - 1994 UBC	1997
New	Approved Basic #96-108498BP	Plan #1813 Rambler Style SFR - 1994 UBC	1997
New	Approved Basic #96-106675BP	Two Story SFR - 1994 UBC	1997
New	Approved Basic #97-105096BP	Plan #2065 Two Story SFR - 1994 UBC	1997
New	Approved Basic #96-110590BP	Plan 1887-S Two Story SFR - 1994 UBC	1997
New	2 story with attached garage		1997
New	2 story with 2 car garage		1997
New	28 X 67 4 1997 Marlette Brookwood		1997
New	Approved Basic #96-109489BP	Plan #1922 Two Story SFR - 1994 UBC	1997
New	24x44 (1983) Fleetwood Berkshire		1997
New	28 x 66 1989 Marlette		1997
New	Rambler with attached garage - 1994 UBC		1997
New	26 x 44 - 1998 - Liberty		1997
New	2-story SFR w/attached garage		1997
New	Rambler with Attached Garage	FINALED BY J.FOSS ON 11/7/97	1997
New	Two-story SFR w/attached garage		1997
New	2-Story SFR w/attached Garage		1997
New	1633-sf Rambler w/attached garage		1997
New	26 x 66 - 1996 Dartmouth		1997
New	26 x 66 - 1996 Dartmouth		1997
New	2 Story SFR with attached garage - 1994 UBC		1997
New	27 x 56 - 1996 Skyline Mobile Home		1997
New	Approved Basic #96-105880BP	Two Story SFR - 1994 UBC (Finaled on 12/4/97 by T.Bryant.)	1997
New	2 story SFR with attached garage		1997
New	Tri-level with 2 car - 1994 UBC		1997
New	1500 SF Rambler		1997
New	2060sf Rambler style SFR with attached garage		1997
New	2760 sf 2-story with 980 sf garage and 63 sf covered porch		1997
New	2824 sf 2-story w/846 sf garage and 240 sf covered deck/porch		1997



Accessory Dwelling Units

Index # - File Name: 1.0022 - Single Family Dwellings Data\_Snohomish County.pdf

New	2057 sf split-level w/630 sf garage and 55 sf covered porch	1997
New	2312 sf 2-story w/443 sf garage and 128 sf covered deck/porch	1997
New	Approved Basic #95-109813BP SFR w/basement - 1994 UBC	1997
New	Rambler w/3 car	1997
New	2 Story SFR with attached garage	1997
New	Approved Basic #96-108269BP Ramber Style SFR - 1994 UBC	1997
New	Approved Basic #97-104176BP 1675 sf rambler w/724 sf garage and 40 sf covered porch	1997
New	Rambler with 2 car garage.	1997
New	Rambler w/ 3 car	1997
New	2- Story SFR with attached garage - 1994 UBC	1997
New	Approved Basic #96-105548BP SFR w/finished basement - 1994 UBC	1997
New	Approved Basic #96-102452BP Two Story SFR w/2 or 3 car garage - 1994 UBC	1997
New	Approved Basic # 97-100006BP #041688 2 Story SFR - 1994 UBC	1997
New	Approved Basic #95-109813BP SFR w/basement - 1994 UBC	1997
New	4 level 2071 s.f. sfr with 2 car garage	1997
New	2-Story SFR w/attached garage	1997
New	Rambler with attached garage	1997
New	1747 SF Rambler with attached garage	1997
New	Approved Basic #96-102452BP Two Story SFR w/2 or 3 car garage - 1994 UBC	1997
New	1974 - 14 x 70 Governor Mobile Home	1997
New	Duplex with 843 SF per unit and attached garages	1997
New	2 story SFR - 1994 UBC	1997
New	SFR w/finished basement - 1994 UBC	1997
New	2 story SFR with 3 car garage	1997
New	2-Story SFR w/attached Garage.	1997
New	2 story w/basement & 3 car	1997
New	28 x48 1996 Fleetwood	1997
New	1997 (60x39) Silvercrest Mobile Home	1997
New	2 story w/ basement & 3 car	1997
New	40x60, Marlette, 1997	1997
New	2-Story 2733 sf SFR with 969 sf attached garage. - 1994 UBC (12/12/97: SEE NOTATION ON OI	1997
New	Approved Basic 97-100812BP Two Story SFR - 1994 UBC	1997
New	2-Story SFR w/attached 3 car garage	1997
New	2-Story SFR w/attached Garage	1997
New	Two Story SFR w/unfinished basement - 1994 UBC	1997
New	Daylight Basement SFR w/unfinished basement.- /7/98- Variance granted to allowed front setbac	1997
New	Rambler with Attached Garage	1997
New	Approved Basic #97-100722BP Plan #2416 Two Story SFR - 1994 UBC	1997
New	Rambler style SFR w/attached garage	1997
New	24 x 64 sf Doublewide Mobile Home (Guest House) - 1994 UBC	1997
New	Approved Basic #96-109827BP Plan 4 Two Story SFR - 1994 UBC	1997
New	1722 SF Rambler with attached garage	1997
New	2 story SFR w/ garage (Finaled by B.Humphreys 12/9/97)	1997
New	Approved Basic #97-103863BP Plan #1820 Rambler Style SFR - 1994 UBC (Finaled b	1997
New	2 story SFR (Finaled by B.Humphreys on 12/9/97)	1997
New	Approved Basic #97-103866BP Plan #1722 Rambler Style SFR - 1994 UBC	1997
New	Approved Basic #97-103863BP Plan #1820 Rambler Style SFR - 1994 UBC	1997

Accessory Dwelling Units

Index # - File Name: 1.0022 - Single Family Dwellings Data\_Snohomish County.pdf

New	1277 sf Tri-level w/490 sf unfinished basement and 440 sf garage		1997
New	Approved Basic #97-103863BP	Plan #1820 Rambler Style SFR - 1994 UBC	1997
New	2-Story SFR with 300-sf Cov. Porch		1997
New	Approved Basic #97-103863BP	Plan #1820 Rambler Style SFR - 1994 UBC	1997
New	Two-story SFR w/attached garage		1997
New	60 x 40.5 Golden Manor II 1997 Triplewide		1997
New	2857 sf 2-story w/492 sf garage and 117 sf covered deck/porch		1997
New	Approved Basic #97-104442BP	2 story sfr with 3 car garage	1997
New	2 story with attached garage	5-23-97 Contractor converted electric to LPG	1997
New	1045 sf rambler w/420 sf garage		1997
New	1268 sq. ft. 2-story w/336 sq. ft. garage		1997
New	2 story SFR with attached garage & covered porch - 1994 UBC		1997
New	28 x 52 (1997) Marlette Lakecrest #9501		1997
New	788 SFR above 24 x 36 Garage		1997
New	One-story SFR w/attached garage		1997
New	Approved Basic #97-107139BP	SFR w/unfinished basement - 1994 UBC	1997
New	Split Level with attached garage and unfinished (semi-finished) basement.		1997
New	Approved Basic #97-107139BP	SFR w/unfinished basement - 1994 UBC	1997
New	Approved Basic #95-110737BP	Rambler Style SFR - 1994 UBC	1997
New	1020 sf SFR with 440 sf attached garage - 1994 UBC		1997
New	SFR w/unfinished basement - 1994 UBC		1997
New	SFR w/unfinished basement - 1994 UBC		1997
New	One-story SFR w/ attached garage		1997
New	Rambler with attached Garage		1997
New	Approved Basic #96-109247BP	Plan #1733 SFR w/finished or unfinished b	1997
New	Approved Basic #96-105868BP	Plan #1430 SFR w/ finished of unfinishec	1997
New	Approved Basic #96-109243BP	Plan #1856 Two Story SFR - 1994 UBC	1997
New	Approved Basic #96-109252BP	Plan #1335 Rambler Style SFR - 1994 UBC	1997
New	Approved Basic #97-104322BP	Plan #1654 Two Story SFR - 1994 UBC	1997
New	Approved Basic #96-109247BP	Plan #1733 SFR w/finished or unfinished b	1997
New	Approved Basic #96-100749BP	SFR w/finished basement - 1994 UBC	1997
New	Approved Basic #97-105382BP	Plan 2032 Two-story SFR w/attached garage	1997
New	Rambler style SFR w/attached garage.		1997
New	2-Story SFR w/attached Garage		1997
New	2-Story SFR with attached garage - 1994 UBC		1997
New	Rambler with attached Garage		1997
New	2-Story SFR w/attached Garage.		1997
New	1549 sf Rambler w/472 sf attached garage		1997
New	14x66, 1984 Fleetwood		1997
New	1907 SF Rambler with attached garage		1997
New	1850 sf one-story w/764 sf attached garage		1997
New	2-Story SFR w/attached garage.		1997
New	1674 sf rambler w/792 sf garage		1997
New	Rambler style SFR w/attached Garage.		1997
New	Approved Basic #97-108671BP	Plan #2127 Rambler Style SFR - 1994 UBC	1997
New	2272 sf Rambler w/538 sf gargage		1997
New	Approved Basic #96-100373BP	SFR w/unfinished basement - 1994 UBC	1997

Accessory Dwelling Units

Index # - File Name: 1.0022 - Single Family Dwellings Data\_Snohomish County.pdf

New	Approved Basic #96-100373BP	SFR w/unfinished basement - 1994 UBC	1997
New	Approved Basic #96-110241BP	Plan 1452 Rambler Style SFR - 1994 UBC	1997
New	1715 sf 2-story w/440 sf garage		1997
New	Approved Basic #96-100373BP	SFR w/unfinished basement - 1994 UBC	1997
New	Approved Basic #97-108775BP	Plan #1716 S Split Level SFR - 1994 UBC	1997
New	Approved Basic #96-100373BP	SFR w/unfinished basement - 1994 UBC	1997
New	Approved Basic #96-100816BP	SFR w/finished basement - 1994 UBC	1997
New	Approved Basic #96-101124BP	SFR w/unfinished basement - 1994 UBC	1997
New	Approved Basic #96-100816BP	SFR w/finished basement - 1994 UBC	1997
New	Approved Basic #96-105640BP	SFR w/finished lower floor - 1994 UBC	1997
New	Approved Basic #96-100373BP	SFR w/unfinished basement - 1994 UBC	1997
New	Approved Basic #96-100373BP	SFR w/unfinished basement - 1994 UBC	1997
New	Approved Basic #96-100373BP	SFR w/unfinished basement - 1994 UBC	1997
New	Approved Basic #96-101124BP	SFR w/unfinished basement - 1994 UBC	1997
New	Approved Basic #96-110241BP	Plan 1452 Rambler Style SFR - 1994 UBC	1997
New	Approved Basic #96-100373BP	SFR w/unfinished basement - 1994 UBC	1997
New	Approved Basic #97-105611BP	Plan #1632 Two Story SFR - 1994 UBC	1997
New	Approved Basic #96-110241BP	Plan 1452 Rambler Style SFR - 1994 UBC	1997
New	Approved Basic #96-100373BP	SFR w/unfinished basement - 1994 UBC	1997
New	Approved Basic #96-110241BP	Plan 1452 Rambler Style SFR - 1994 UBC	1997
New	Approved Basic #96-101124BP	SFR w/unfinished basement - 1994 UBC	1997
New	Two Story SFR - 1994 UBC		1997
New	Approved Basic #96-100373BP	SFR w/unfinished basement - 1994 UBC	1997
New	Approved Basic #96-101119BP	Ramble Style SFR - 1994 UBC	1997
New	Approved Basic #96-105640BP	SFR w/finished lower floor - 1994 UBC	1997
New	Approved Basic #96-100816BP	(Permit finaled by H. Reeves) SFR w/finished basement - 1994 UBC	1997
New	Approved Basic #96-101119BP	Ramble Style SFR - 1994 UBC	1997
New	One story SFR w/attached garage		1997
New	Single Story Duplex w/two 1 car garages		1997
New	SFR. Intent is to convert to bed & breakfast at a later time.		1997
New	14x56, 1979 Fleetwood		1997
New	Approved Basic #96-110600BP	Plan #1833 w/bonus Two Story SFR - 1994 UBC	1997
New	Approved Basic #96-110606BP	Plan 2031 Two Story SFR - 1994 UBC	1997
New	Approved Basic #96-110602BP	Plan 2031w/bonus Two Story SFR - 1994 U	1997
New	Approved Basic #96-110602BP	Plan 2031w/bonus Two Story SFR - 1994 U	1997
New	Approved Basic #96-110602BP	Plan 2031w/bonus Two Story SFR - 1994 U	1997
New	Approved Basic #96-110606BP	Plan 2031 Two Story SFR - 1994 UBC	1997
New	Approved Basic #96-110602BP	Plan 2031 Two Story SFR - 1994 UBC	1997
New	Approved Basic #96-110602BP	Plan 2031w/bonus Two Story SFR - 1994 U	1997
New	Approved Basic #96-110600BP	Plan #1833 w/bonus Two Story SFR - 1994 UBC	1997
New	Approved Basic #96-110602BP	Plan 2031w/bonus Two Story SFR - 1994 U	1997
New	2 story w/3 car		1997
New	Split Level SFR - 1994 UBC		1997
New	2511 sf 2- Story SFR with 732 sf attatched garage - 1994 UBC		1997
New	Approved Basic #96-109243BP	Plan #1856 Two Story SFR - 1994 UBC	1997
New	Approved Basic #96-105868BP	Plan #1430 SFR w/ finished of unfinishec	1997
New	Approved Basic #96-105865BP	Plan #1090 SFR w/finished or unfinishec	1997

Accessory Dwelling Units

Index # - File Name: 1.0022 - Single Family Dwellings Data\_Snohomish County.pdf

New	Approved Basic #96-109243BP	Plan #1856	Two Story SFR - 1994 UBC	1997
New	2 Story SFR with attached garage			1997
New	Approved Basic #96-109247BP	Plan #1733	SFR w/finished or unfinished b	1997
New	Approved Basic #96-109247BP	Plan #1733	SFR w/finished or unfinished b	1997
New	Approved Basic #96-109243BP	Plan #1856	Two Story SFR - 1994 UBC	1997
New	Two Story SFR - 1994 UBC	Plan #1856		1997
New	Approved Basic #96-105868BP	Plan #1430	SFR w/ finished of unfinishec	1997
New	Approved Basic #96-109247BP	Plan #1733	SFR w/finished or unfinished b	1997
New	Approved Basic #96-107398BP	Plan #1220	Rambler Style SFR - 1994 UBC	1997
New	Approved Basic #96-105865BP	Plan #1090	SFR w/finished or unfinishe	1997
New	Approved Basic #96-109243BP	Plan #1856	Two Story SFR - 1994 UBC	1997
New	Approved Basic #96-109247BP	Plan #1733	SFR w/finished or unfinished b	1997
New	Approved Basic #96-105868BP	Plan #1430	SFR w/ finished of unfinishec	1997
New	Approved Basic #96-105868BP	Plan #1430	SFR w/ finished of unfinishec	1997
New	Two-story SFR w/attached garage			1997
New	Approved Basic #96-110592BP	Plan #9302	Two Story SFR - 1994 UBC	1997
New	Two Story SFR - 1994 UBC	Plan #2018		1997
New	Approved Basic #97-105096BP	Plan #2065	Two Story SFR - 1994 UBC	1997
New	Approved Basic #97-105096BP	Plan #2065	Two Story SFR - 1994 UBC	1997
New	Approved Basic #96-109905BP	Plan 1917	Two Story SFR - 1994 UBC	1997
New	Approved Basic #96-110590BP	Plan 1887-S	Two Story SFR - 1994 UBC	1997
New	Approved Basic #95-110544BP	Plan: 2137 2/3	2 story SFR-2 or 3 car garage- 19	1997
New	Two Story SFR - 1994 UBC	Plan #2018		1997
New	Approved Basic #96-109288BP	Two Story SFR - 1994 UBC	Plan 1887 -2/3	1997
New	Approved Basic #96-109132BP	Plan #2154	Two Story SFR - 1994 UBC	1997
New	Approved Basic #96-110590BP	Plan 1887-S	Two Story SFR - 1994 UBC	1997
New	Approved Basic #97-104675BP	Plan 1708	SFR w/finished basement - 1994 U	1997
New	Two Story SFR - 1994 UBC	Plan #1959		1997
New	Rambler Style SFR - 1994 UBC			1997
New	Approved Basic #96-109132BP	Plan #2154	Two Story SFR - 1994 UBC	1997
New	Approved Basic #97-105096BP	Plan #2065	Two Story SFR - 1994 UBC	1997
New	Approved Basic #97-109093BP	Plan #2018	Two Story SFR - 1994 UBC	1997
New	Approved Basic #96-103802BP	Plan: #1884 - 2/3	Two Story SFR - 1994 UBC	1997
New	Two Story SFR - 1994 UBC	Plan #1887-2		1997
New	Approved Basic #95-110544BP	Plan: 2137 2/3	2 story SFR-2 or 3 car garage- 19	1997
New	Approved Basic #96-109132BP	Plan #2154	Two Story SFR - 1994 UBC	1997
New	Approved Basic #96-109905BP	Plan 1917	Two Story SFR - 1994 UBC	1997
New	Approved Basic #97-103094BP	Plan #9310-1	Two Story SFR - 1994 UBC	1997
New	Approved Basic #97-109093BP	Plan #2018	Two Story SFR - 1994 UBC	1997
New	Approved Basic #97-105096BP	Plan #2065	Two Story SFR - 1994 UBC	1997
New	Approved Basic #96-109905BP	Plan 1917	Two Story SFR - 1994 UBC	1997
New	Approved Basic #96-103802BP	Plan: #1884 - 2/3	Two Story SFR - 1994 UBC	1997
New	2 Story w/2 Car	Builders Plan #1938	Approved Basic 97-111017BP	1997
New	SFR w/finished basement - 1994 UBC			1997
New	Approved Basic #96-109132BP	Plan #2154	Two Story SFR - 1994 UBC	1997
New	Approved Basic #95-110544BP	Plan: 2137 2/3	2 story SFR-2 or 3 car garage- 19	1997
New	Approved Basic #96-103802BP	Plan #1884 2/3	Two Story SFR - 1994 UBC	1997

Accessory Dwelling Units

Index # - File Name: 1.0022 - Single Family Dwellings Data\_Snohomish County.pdf

New	Two Story SFR - 1994 UBC	Plan #9514	1997
New	Two-story SFR w/attached garage		1997
New	Approved Basic #95-110105BP	Plan 1715 Two Story SFR - 1994 UBC	1997
New	Approved Basic #95-110544BP	Plan: #2137- 2/3 2 story SFR-2 or 3 car garage-1	1997
New	Approved Basic #96-109132BP	Plan #2154 Two Story SFR - 1994 UBC	1997
New	Two Story SFR - 1994 UBC	Plan #2154	1997
New	Approved Basic #96-110590BP	Plan 1887-S Two Story SFR - 1994 UBC	1997
New	Approved Basic #96-103802BP	Plan: #1884 -2/3 Two Story SFR - 1994 UBC	1997
New	Approved Basic #96-103802BP	Plan: #1884 Two Story SFR - 1994 UBC	1997
New	Rambler w/2 car		1997
New	2-Story SFR w/attached garage		1997
New	Rambler Style SFR - 1994 UBC	Plan #1362 R/2	1997
New	Two Story SFR - 1994 UBC	Plan #1361/2	1997
New	SFR w/finished lower floor - 1994 UBC	Plan #1402 T-A-B/2	1997
New	Two Story SFR - 1994 UBC	Plan #1430 A/2	1997
New	Approved Basic #97-103609BP	Plan #1430 Two Story SFR - 1994 UBC 3/6/98 -	1997
New	Approved Basic #97-103613BP	Plan #1361 Two Story SFR - 1994 UBC (Fi	1997
New	Approved Basic #97-103609BP	Plan #1430 Two Story SFR - 1994 UBC 3/6/98 -	1997
New	Approved Basic #97-103607BP	Plan #1485 Two Story SFR - 1994 UBC	1997
New	Approved Basic #97-103610BP	Plan #1441 SFR w/finished basement - 1994	1997
New	Two Story SFR - 1994 UBC	Plan #1485 A/2	1997
New	Approved Basic #97-103613BP	Plan #1361 Two Story SFR - 1994 UBC	1997
New	Approved Basic #97-103609BP	Plan #1430 Two Story SFR - 1994 UBC 3/6/98 -	1997
New	Approved Basic #97-103609BP	Plan #1430 Two Story SFR - 1994 UBC 3/6/98 -	1997
New	Approved Basic #97-103610BP	Plan #1441 SFR w/finished basement - 1994	1997
New	Approved Basic #97-103607BP	Plan #1485 Two Story SFR - 1994 UBC	1997
New	Approved Basic #97-103610BP	Plan #1441 SFR w/finished basement - 1994	1997
New	Approved Basic #97-103607BP	Plan #1485 Two Story SFR - 1994 UBC (Fi	1997
New	Approved Basic #97-103604BP	Plan #1362 Rambler Style SFR - 1994 UBC	1997
New	Approved Basic #97-103604BP	Plan #1362 Rambler Style SFR - 1994 UBC	1997
New	Approved Basic #97-103604BP	Plan #1362 Rambler Style SFR - 1994 UBC	1997
New	Approved Basic #97-103607BP	Plan #1485 Two Story SFR - 1994 UBC	1997
New	Approved Basic #97-103604BP	Plan #1362 Rambler Style SFR - 1994 UBC	1997
New	Approved Basic #97-103607BP	Plan #1485 Two Story SFR - 1994 UBC	1997
New	Two Story SFR - 1994 UBC	Plan #2036	1997
New	Approved Basic #96-109477BP	Plan 1947 Two Story SFR - 1994 UBC	1997
New	2 Story w/3 car		1997
New	Approved Basic #97-104977BP	Plan: #2072 Two Story SFR - 1994 UBC	1997
New	Approved Basic #97-104977BP	Plan: #2072 Two Story SFR - 1994 UBC	1997
New	Approved Basic #97-104979	Plan #2036 Two Story SFR - 1994 UBC	1997
New	Approved Basic #97-104979	Plan #2036 Two Story SFR - 1994 UBC	1997
New	Approved Basic #97-104977BP	Plan: #2072 Two Story SFR - 1994 UBC	1997
New	Two Story SFR - 1994 UBC	Plan: 2036	1997
New	Rambler style SFR		1997
New	27 x 60 Skyline Mobile Home		1997
New	2 story sfr with 2 car garage		1997
New	Rambler w/2 car		1997

Accessory Dwelling Units

Index # - File Name: 1.0022 - Single Family Dwellings Data\_Snohomish County.pdf

New	Approved Basic #97-103797BP	Plan #1107	Rambler Style SFR - 1994 UBC	1997
New	Approved Basic #97-103497BP	Plan #1107	Rambler Style SFR - 1994 UBC	1997
New	1283 sf 2 Story SFR with/attached garage			1997
New	Approved Basic #97-103604BP	Plan #1362	Rambler Style SFR - 1994 UBC	1997
New	Approved Basic #97-103607BP	Plan #1485	Two Story SFR - 1994 UBC	1997
New	Two Story SFR - 1994 UBC	Plan #1232/2		1997
New	2-Story SFR w/unfin. basement & attached garage.			1997
New	2 story w/2 car			1997
New	Approved Basic #97-105339BP	Two Story SFR - 1994 UBC		1997
New	Rambler style SFR			1997
New	2307 s.f. rambler with 3 car garage and 1 car carport.			1997
New	Tri-level SFR - 1994 UBC			1997
New	2-Story SFR with unfinished basement and attached garage - 1994 UBC			1997
New	2-Story SFR with attached Carport			1997
New	2596 2-story with 680 sf garage and 96 sf covered deck/porch			1997
New	One-story SFR w/attached garage			1997
New	4444 sf 2-Story SFR with 2400 sf attached garage - 1994 UBC			1997
New	Rambler Style SFR - 1994 UBC	Plan #1788		1997
New	2 story sfr with 3 car garage			1997
New	27x44, 1997 Marlette			1997
New	Rambler style SFR w/attached Garage			1997
New	27x56 1997 Fleetwood			1997
New	Mid-Entry w/2 car			1997
New	27 x 60 1997 Fleetwood			1997
New	Two Story SFR - 1994 UBC	Plan 1986		1997
New	Rambler Style SFR - 1994 UBC	Plan #1438		1997
New	Rambler Style SFR - 1994 UBC	Plan #f1701		1997
New	Two Story SFR - 1994 UBC	Plan #1649		1997
New	Two-story SFR w/attached garage (Finaled by B.Humphreys on 12/9/97)			1997
New	One-story SFR w/attached garage			1997
New	Approved Basic #97-108906BP	Split Level SFR with attached garage		1997
New	Approved Basic #96-104979BP	Plan #1551	Rambler Style SFR - 1994 UBC	Optic 1997
New	Approved Basic #97-105540BP	Plan #1643	Tri-Level SFR w/finished lower f	1997
New	Approved Basic #96-104979BP	Plan #1551	Rambler Style SFR - 1994 UBC	Optic 1997
New	Approved Basic #97-107392BP	Plan #1812	Rambler Style SFR - 1994 UBC	1997
New	Approved Basic #96-104979BP	Plan #1551	Rambler Style SFR - 1994 UBC	Optic 1997
New	Rambler Style SFR - 1994 UBC			1997
New	Approved Basic #97-103533BP	SFR w/unfinished & unheated lower floor - 1994 UBC		1997
New	2 story w/ 2 car			1997
New	Rambler w/bsmt & 3 car			1997
New	1223 sq. ft. 2-story w/390 sq. ft. unfinished basement and 438 sq. ft. garage			1997
New	2 Story w/3 Car			1997
New	66 x 27 1997 Palm Harbour			1997
New	Two Story SFR - 1994 UBC			1997
New	Approved Basic #97-105249BP	0 Lot Line Structure	Rambler Style SFR - 1994 UBC	1997
New	Approved Basic #97-105249BP	0 Lot Line Structure	Rambler Style SFR - 1994 UBC	1997
New	Approved Basic #97-105249BP	0 Lot Line Structure	Rambler Style SFR - 1994 UBC	1997

Accessory Dwelling Units

Index # - File Name: 1.0022 - Single Family Dwellings Data\_Snohomish County.pdf

New	Approved Basic #97-105249BP	0 Lot Line Structure	Rambler Style SFR - 1994 UBC	1997
New	Approved Basic #97-105249BP	0 Lot Line Structure	Rambler Style SFR - 1994 UBC	1997
New	Approved Basic #97-105249BP	0 Lot Line Structure	Rambler Style SFR - 1994 UBC	1997
New	Approved Basic #97-105249BP	0 Lot Line Structure	Rambler Style SFR - 1994 UBC	1997
New	Approved Basic #97-105249BP	0 Lot Line Structure	Rambler Style SFR - 1994 UBC	1997
New	Approved Basic #97-105249BP	0 Lot Line Structure	Rambler Style SFR - 1994 UBC	1997
New	Approved Basic #97-105249BP	0 Lot Line Structure	Rambler Style SFR - 1994 UBC	1997
New	Approved Basic #97-105249BP	0 Lot Line Structure	Rambler Style SFR - 1994 UBC	1997
New	Approved Basic #97-105249BP	0 Lot Line Structure	Rambler Style SFR - 1994 UBC	1997
New	Approved Basic #95-109540BP	(0 lot line structure)	1994 UBC-SFR Rambler	1997
New	Approved Basic #95-109540BP	(0 lot line structure)	1994 UBC-SFR Rambler	1997
New	Approved Basic #95-109540BP	(0 lot line structure)	1994 UBC-SFR Rambler	1997
New	Approved Basic #95-109540BP	(0 lot line structure)	1994 UBC-SFR Rambler	1997
New	Approved Basic #95-109540BP	(0 lot line structure)	1994 UBC-SFR Rambler	1997
New	Approved Basic #95-109540BP	(0 lot line structure)	1994 UBC-SFR Rambler	1997
New	Approved Basic #95-109540BP	(0 lot line structure)	1994 UBC-SFR Rambler	1997
New	Approved Basic #95-109540BP	(0 lot line structure)	1994 UBC-SFR Rambler	1997
New	1544 s.f. rambler with 2 car garage.			1997
New	Two Story Duplex - 1994 UBC			1997
New	Approved Basic #97-105475BP	Two Story SFR - 1994 UBC		1997
New	Rambler style SFR w/attached garage.			1997
New	One-story SFR w/attached garage			1997
New	Two-story SFR w/attached garage			1997
New	Rambler style SFR with attached garage			1997
New	Two Story SFR - 1994 UBC			1997
New	Rambler Style SFR - 1994 UBC			1997
New	SFR w/finished basement - 1994 UBC	Plan 2215		1997
New	Two Story SFR - 1994 UBC	Plan 2204		1997
New	Two Story SFR - 1994 UBC	Plan 2207		1997
New	Two Story SFR - 1994 UBC	Plan #2209 C/E		1997
New	2 story log home	Reference 97-100447 AB for garage.		1997
New	12 x 60 Westwood/Fleetwood	1971		1997
New	2-Story SFR w/attached Garage			1997
New	2- Story SFR with attached garage - 1994 UBC			1997
New	Approved Basic #97-100261BP	Plan #1827 B-3	Rambler Style SFR - 1994	1997
New	Rambler with garage - 1994 UBC			1997
New	Approved Basic #96-103850BP	Two Story SFR - 1994 UBC		1997
New	Two Story SFR - 1994 UBC		Plan #	1997
New	Approved Basic #97-100067BP	Plan #2245	SFR w/finished basement - 1994 U	1997
New	Approved Basic #97-100708	Plan #2066	Two Story SFR - 1994 UBC	1997
New	Rambler Style SFR - 1994 UBC			1997
New	Approved Basic #96-103849BP	Two Story SFR -1994 UBC		1997
New	Approved Basic #97-100708BP	Plan #2066	Two Story SFR - 1994 UBC	1997
New	Approved Basic #97-100067BP	Plan #2245	SFR w/finished basement - 1994 U	1997
New	Approved Basic #96-103850BP	Two Story SFR - 1994 UBC		1997
New	Approved Basic #97-102039BP	Plan #467-3	Two Story SFR - 1994 UBC	1997
New	Approved Basic #96-103850BP	Two Story SFR - 1994 UBC		1997

Accessory Dwelling Units

Index # - File Name: 1.0022 - Single Family Dwellings Data\_Snohomish County.pdf

		Plan #	Year
New	SFR w/finished basement - 1994 UBC		1997
New	Two Story SFR - 1994 UBC	Plan #2066	1997
New	Approved Basic #97-101908BP	Plan #125 Rambler style SFR w/attached gara	1997
New	Rambler Style SFR - 1994 UBC		1997
New	Approved Basic #96-106959BP	Plan #2108 Two Story SFR - 1994 UBC	1997
New	Approved Basic #96-103264BP	Plan #2317 Two Story SFR - 1994 UBC (Finale	1997
New	Approved Basic #96-102874BP	Plan #2259 Two Story SFR - 1994 UBC. (Finale	1997
New	Approved Basic #95-106646BP	Plan #2444 Two Story SFR - 1994 UBC	1997
New	Approved Basic #96-106959BP	Plan #2108 Two Story SFR - 1994 UBC	1997
New	Approved Basic #96-102874BP	Plan #2259 Two Story SFR - 1994 UBC	1997
New	Approved Basic #95- 108133BP	Plan #1655 Tri-Level SFR - 1994 UBC	1997
New	Approved Basic #96-102270BP	Plan #2054 Two Story SFR - 1994 UBC	1997
New	Approved Basic #95-108812BP	Plan #1384 Two Story SFR - 1994 UBC	1997
New	Approved Basic #95- 108133BP	Plan #1655 Tri-Level SFR - 1994 UBC	1997
New	Approved Basic #95-108812BP	Plan #1384 Two Story SFR - 1994 UBC	1997
New	Approved Basic #95- 108133BP	Plan #1655 Tri-Level SFR - 1994 UBC	1997
New	2-Story SFR w/attached garage.		1997
New	Approved Basic #97-101584BP	Plan #1895 Two Story SFR - 1994 UBC	1997
New	Approved Basic #97-104822BP	Plan #1775 Two Story SFR - 1994 UBC	1997
New	1639 sf 2-story with 647 sf garage and 112 sf covered deck/porch		1997
New	Two Story SFR - 1994 UBC	Plan #1389	1997
New	1380 sf 2-story with 651 sf garage and 70 sf covered deck/porch		1997
New	Approved Basic #97-104831BP	Plan 1639 Two Story SFR - 1994 UBC	1997
New	Approved Basic #95- 108133BP	Plan #1655 Tri-Level SFR - 1994 UBC	1997
New	Approved Basic #96-100746BP	Plan #1552 Rambler Style SFR - 1994 UBC	1997
New	Approved Basic #95- 108133BP	Plan #1655 Tri-Level SFR - 1994 UBC	1997
New	Approved Basic #97-104829BP	Plan #1661 Two Story SFR - 1994 UBC	1997
New	Approved Basic #97-104558BP	Plan 1380 Two Story SFR - 1994 UBC	1997
New	Approved Basic #97-104822BP	Plan #1775 Two Story SFR - 1994 UBC	1997
New	Approved Basic #97-104556BP	Plan #1389 Two Story SFR - 1994 UBC	1997
New	Approved Basic #97-101584BP	Plan #1895 Two Story SFR - 1994 UBC	1997
New	Approved Basic #97-104822BP	Plan #1775 Two Story SFR - 1994 UBC	1997
New	Approved Basic #97-101584BP	Plan #1895 Two Story SFR - 1994 UBC	1997
New	Approved Basic #95-108812BP	Plan #1384 Two Story SFR - 1994 UBC	1997
New	Approved Basic #95- 108133BP	Plan #1655 Tri-Level SFR - 1994 UBC	1997
New	Approved Basic #95-109726BP (THIS BASIC IS ONLY APPROVED FOR 2 CAR)	Two Story SFR - 19	1997
New	Approved Basic #96-100746BP	Plan #1552 Rambler Style SFR - 1994 UBC	1997
New	Approved Basic #95-109726BP (THIS BASIC IS ONLY APPROVED FOR 2 CAR)	Two Story SFR - 19	1997
New	Approved Basic #96-102270BP	Plan #2054 Two Story SFR - 1994 UBC	1997
New	Approved Basic #95- 108133BP	Plan #1655 Tri-Level SFR - 1994 UBC	1997
New	Approved Basic #96-100746BP	Plan #1552 Rambler Style SFR - 1994 UBC	1997
New	Approved Basic #95-109726BP (THIS BASIC IS ONLY APPROVED FOR 2 CAR)	Two Story SFR - 19	1997
New	Approved Basic #95- 108133BP	Plan #1655 Tri-Level SFR - 1994 UBC	1997
New	Approved Basic #95-109726BP Two Story SFR - 1994 UBC	Option Approved - Elv. C & 3r	1997
New	Approved Basic #95-109726BP (THIS BASIC IS ONLY APPROVED FOR 2 CAR)	Two Story SFR - 19	1997
New	Approved Basic #97-104822BP	Plan #1775 Two Story SFR - 1994 UBC	1997
New	Approved Basic #97-106548BP	Plan #2143 Two Story SFR - 1994 UBC	1997





Accessory Dwelling Units

Index # - File Name: 1.0022 - Single Family Dwellings Data\_Snohomish County.pdf

New	Approved Basic #97-100843BP	Plan 1309	Two Story SFR - 1994 UBC	1997
New	Two Story SFR - 1994 UBC	Plan #1309		1997
New	Approved Basic #97-100843BP	Plan 1309	Two Story SFR - 1994 UBC	1997
New	Approved Basic #97-100843BP	Plan 1309	Two Story SFR - 1994 UBC	1997
New	Approved Basic #97-100843BP	Plan 1309	Two Story SFR - 1994 UBC	1997
New	Approved Basic #97-100843BP	Plan 1309	Two Story SFR - 1994 UBC	1997
New	Approved Basic #97-100843BP	Plan 1309	Two Story SFR - 1994 UBC	1997
New	Approved Basic #97-100843BP	Plan 1309	Two Story SFR - 1994 UBC	1997
New	Approved Basic #97-100843BP	Plan 1309	Two Story SFR - 1994 UBC	1997
New	Approved Basic #97-100843BP	Plan 1309	Two Story SFR - 1994 UBC	1997
New	Approved Basic #97-100843BP	Plan 1309	Two Story SFR - 1994 UBC	1997
New	FOAMING COMPLETED 10/29/97 - CECIL KOCH	Approved Basic #97-100843BP		1997
New	Approved Basic #97-100843BP	Plan 1309	Two Story SFR - 1994 UBC	1997
New	Approved Basic #97-100843BP	Plan 1309	Two Story SFR - 1994 UBC	1997
New	Approved Basic #97-100843BP	Plan 1309	Two Story SFR - 1994 UBC	1997
New	Approved Basic #97-100843BP	Plan 1309	Two Story SFR - 1994 UBC	1997
New	Approved Basic #97-100843BP	Plan 1309	Two Story SFR - 1994 UBC	1997
New	Approved Basic #97-100843BP	Plan 1309	Two Story SFR - 1994 UBC	1997
New	Approved Basic #97-100843BP	Plan 1309	Two Story SFR - 1994 UBC	1997
New	Approved Basic #97-100843BP	Plan 1309	Two Story SFR - 1994 UBC	1997
New	FOAMING COMPLETED 10/29/97 - CECIL KOCH	Approved Basic #97-100843BP		1997
New	Approved Basic #97-100843BP	Plan 1309	Two Story SFR - 1994 UBC	1997
New	2 Story SFR with attached garage - 1994 UBC			1997
New	2 story w/1 car			1997
New	28x66 (1997) Marlette			1997
New	2212 sf 2-Story SFR with 679 sf attached garage - 1994 UBC			1997
New	28 x 70 (1997) Barrington			1997
New	Approved Basic #97-106334BP	Plan 1938	Two Story SFR - 1994 UBC	1997
New	Rambler Style Duplex - 1994 UBC			1997
New	Rambler Style Duplex - 1994 UBC			1997
New	2682 sf 2-Story SFR with 705 sf attached garage - 1994 UBC			1997
New	1 story SFR			1997
New	One-story SFR w/attached garage			1997
New	1983 Citation MH			1997
New	Approved Basic #97-100342BP	Plan #2207	Two Story SFR - 1994 UBC	1997
New	Approved Basic #96-110885BP	Plan 2209 C/E	Two Story SFR - 1994 UBC	1997
New	Approved Basic #96-110883BP	Plan #2209 B/D	Two Story SFR - 1994 UB	1997
New	Approved Basic 97-102161BP	Plan #2217A	Two Story SFR - 1994 UBC	1997
New	Two Story SFR - 1994 UBC			1997
New	Two Story SFR - 1994 UBC	Plan #2301		1997
New	Approved Basic #96-110885BP	Plan 2209 C/E	Two Story SFR - 1994 UBC	1997
New	Two Story SFR - 1994 UBC	Plan #2208 A-2		1997
New	Approved Basic #97-100338BP	Plan #2204	Two Story SFR - 1994 UBC	1997
New	Approved Basic #96-110885BP	Plan 2209 C/E	Two Story SFR - 1994 UBC	1997
New	Approved Basic #96-110883BP	Plan #2209 B/D	Two Story SFR - 1994 UB	1997
New	Approved Basic #97-100342BP	Plan #2207	Two Story SFR - 1994 UBC	1997
New	Approved Basic #97-100338BP	Plan #2204	Two Story SFR - 1994 UBC	1997

Accessory Dwelling Units

Index # - File Name: 1.0022 - Single Family Dwellings Data\_Snohomish County.pdf

New	Approved Basic #96-110885BP	Plan 2209 C/E	Two Story SFR - 1994 UBC	1997
New	Approved Basic #97-100342BP	Plan #2207	Two Story SFR - 1994 UBC	1997
New	Approved Basic #96-110885BP	Plan 2209 C/E	Two Story SFR - 1994 UBC	1997
New	SFR w/finished basement - 1994 UBC	Plan #2211AB		1997
New	SFR w/finished basement - 1994 UBC	Plan #2210 D		1997
New	Approved Basic #96-110878BP	SFR w/finished basement - 1994 UBC	Plan #2215	1997
New	SFR w/finished basement - 1994 UBC	Plan #2209 CB		1997
New	Approved Basic #97-100338BP	Plan #2204	Two Story SFR - 1994 UBC	1997
New	SFR w/finished basement - 1994 UBC	Plan #2211 AB		1997
New	SFR w/finished basement - 1994 UBC	Plan #2209 CB		1997
New	SFR w/finished basement - 1994 UBC	Plan #2204B		1997
New	2 story with attached garage -			1997
New	Two Story SFR - 1994 UBC			1997
New	Two Story SFR - 1994 UBC			1997
New	Approved Basic #97-101124BP	Plan #2211A	Two Story SFR - 1994 UBC	1997
New	Approved Basic #96-110885BP	Plan 2209 C/E	Two Story SFR - 1994 UBC	1997
New	Approved Basic #97-101124BP	Plan #2211A	Two Story SFR - 1994 UBC	1997
New	Approved Basic #97-100338BP	Plan #2204	Two Story SFR - 1994 UBC	1997
New	Approved Basic #96-110883BP	Plan #2209 B/D	Two Story SFR - 1994 UBC	1997
New	Approved Basic #96-110885BP	Plan 2209 C/E	Two Story SFR - 1994 UBC	1997
New	Approved Basic #96-110883BP	Plan #2209 B/D	Two Story SFR - 1994 UBC	1997
New	2 Story SFR w/attached Garage			1997
New	2-Story SFR w/attached Garage			1997
New	2 story SFR w/ garage			1997
New	1 story rambler w/ garage			1997
New	2 Story Rambler with daylight basement - 1994 UBC			1997
New	2308 sf 2-story w/1312 sf unfinished basement and 514 sf garage w/84 sf covered deck/porch			1997
New	27x70, 1997 Palm Harbor (Truman)			1997
New	2-Story over daylight basement SFR w/attached garage			1997
New	66x38.5, 1997 Fleetwood			1997
New	SFR w/finished basement - 1994 UBC			1997
New	SFR w/finished basement - 1994 UBC			1997
New	Two Story SFR - 1994 UBC			1997
New	28 x 56 1996 Ardmere Mobile Home			1997
New	Approved Basic #97-106032BP	Two Story SFR - 1994 UBC		1997
New	14 x 52 1978 Ridgewood			1997
New	Approved Basic #95-108472BP	Rambler Style SFR - 1994 UBC		1997
New	Approved Basic #95-108472BP	Rambler Style SFR - 1994 UBC		1997
New	Approved Basic #95-108472BP	Rambler Style SFR - 1994 UBC		1997
New	Approved Basic #95-109256BP	Rambler Style SFR - 1994 UBC		1997
New	Approved Basic #95-108472BP	Rambler Style SFR - 1994 UBC		1997
New	Approved Basic #95-108472BP	Rambler Style SFR - 1994 UBC		1997
New	Approved Basic #95-109256BP	Rambler Style SFR - 1994 UBC		1997
New	Approved Basic #95-108472BP	Rambler Style SFR - 1994 UBC		1997
New	Approved Basic #95-108472BP	Rambler Style SFR - 1994 UBC		1997
New	Approved Basic #95-108472BP	Rambler Style SFR - 1994 UBC		1997
New	Approved Basic #95-108472BP	Rambler Style SFR - 1994 UBC		1997

Accessory Dwelling Units

Index # - File Name: 1.0022 - Single Family Dwellings Data\_Snohomish County.pdf

New	Approved Basic #97-102318BP	Rambler Style SFR - 1994 UBC	1997
New	Approved Basic #95-109256BP	Rambler Style SFR - 1994 UBC	1997
New	Rambler style SFR w/attached Garage		1997
New	Rambler style SFR w/attached garage.		1997
New	Approved Basic #95-108472BP	Rambler Style SFR - 1994 UBC	1997
New	Approved Basic #95-108472BP	Rambler Style SFR - 1994 UBC	1997
New	Approved Basic #95-108472BP	Rambler Style SFR - 1994 UBC	1997
New	Approved Basic #95-108472BP	Plan 1446 Rambler Style SFR - 1994 UBC	1997
New	Approved Basic #95-108472BP	Plan 1446 Rambler Style SFR - 1994 UBC	1997
New	Approved Basic #95-108472BP	Plan 1446 Rambler Style SFR - 1994 UBC	1997
New	Approved Basic #95-109256BP	Plan #1520 Rambler Style SFR - 1994 UBC	1997
New	Approved Basic #95-108472BP	Plan 1446 Rambler Style SFR - 1994 UBC	1997
New	Approved Basic #95-108472BP	Rambler Style SFR - 1994 UBC	1997
New	Approved Basic #95-108472BP	Rambler Style SFR - 1994 UBC	1997
New	Approved Basic #95-108472BP	Rambler Style SFR - 1994 UBC	1997
New	Approved Basic #95-109256BP	Plan #1520 Rambler Style SFR - 1994 UBC	1997
New	Approved Basic #96-105824BP	Rambler Style SFR - 1994 UBC	1997
New	28 x 66	1992 Fleetwood	1997
New	28x40	1087 Brookshire(Fleetwood)	1997
New	24 x 44	- 1983 Fleetwood-Berkshire Mobile Home	1997
New	28 x 56	- 1994 Fleetwood. NON OCCUPANCY NOTICE POSTED 4/12/00 BY CECIL KOCH.	1997
New	2 story w/	3 car	1997
New	12x52	(1969) Lamplighter	1997
New	2 story sfr	with 3 car garage	1997
New	2-story SFR	with 552 attached garage. - 1994 UBC	1997
New	Approved Basic #96-110602BP	Plan 2031w/bonus Two Story SFR - 1994 U	1997
New	832 sf	2-story SFR w/1152 sf garage	1997
New	2117 sf	One-story SFR w/ 488 sf attached garage	1997
New	One-story SFR	w/unfin bsmt & attached garage	1997
New	24 x 48	doublewide	1997
New	2-Story SFR	w/attached Garage	1997
New	Daylight basement SFR	w/attached garage. (1/2/98 applicant changed from 250 to 500 gallon l	1997
New	Approved Basic #96-104561BP	Plan #KTH 3-A Two Story SFR - 1994 UBC	1997
New	Approved Basic #95-106336BP	Option approved for floor joist changes 9/15/95 Two Story SFR	1997
New	Approved Basic #96-104566BP	Plan #KTH 4-A Two Story SFR - 1994 UBC Optior	1997
New	Approved Basic #96-104563BP	Plan #KTH 6-A Two Story SFR - 1994 UBC	1997
New	Approved Basic #96-105586BP	Plan #KTH 3-B Two Story SFR - 1994 UBC	1997
New	Approved Basic #96-104788BP	Plan #GH 5-A Two Story SFR - 1994 UBC	1997
New	Approved Basic #96-105590BP	Plan KTH 2B Two Story SFR - 1994 UBC	1997
New	Approved Basic #96-104561BP	Plan #KTH 3-A Two Story SFR - 1994 UBC	1997
New	Approved Basic #96-104562BP	Plan #KTH 2-A Two Story SFR - 1994 UBC Reinsp	1997
New	Approved Basic #96-104788BP	Plan #GH 5-A Two Story SFR - 1994 UBC	1997
New	Approved Basic #96-104564BP	Plan #KTH 1-A Two Story SFR - 1994 UBC	1997
New	Approved Basic #96-104566BP	Plan #KTH 4-A Two Story SFR - 1994 UBC Optior	1997
New	Approved Basic #96-105591BP	Plan #KTH 1-B Two Story SFR - 1994 UBC	1997
New	Approved Basic #96-105590BP	Plan KTH 2B Two Story SFR - 1994 UBC	1997
New	Approved Basic #95-106336BP	Option approved for floor joist changes 9/15/95 Two Story SFR	1997

Accessory Dwelling Units

Index # - File Name: 1.0022 - Single Family Dwellings Data\_Snohomish County.pdf

New	Approved Basic #95-105317BP	Floor Framing Option Approved 9/15/95	Two Story SFR - 1994	1997
New	Approved Basic #96-104566BP	Plan #KTH 4-A	Two Story SFR - 1994 UBC	1997
New	Approved Basic #95-106333BP	Option Approved - 3rd car & floor joists option 9/15/95	Two Story SFR - 1994 UBC	1997
New	Approved Basic #95-105317BP	Floor Framing Option Approved 9/15/95	Two Story SFR - 1994	1997
New	Approved Basic #96-105586BP	Plan #KTH 3-B	Two Story SFR - 1994 UBC	1997
New	Approved Basic #96-104562BP	Plan #KTH 2-A	Two Story SFR - 1994 UBC	1997
New	Approved Basic #96-104208BP	Plan #GH 3-A	Two Story SFR - 1994 UBC	1997
New	Approved Basic #96-104561BP	Plan #KTH 3-A	Two Story SFR - 1994 UBC	1997
New	New SFR			1997
New	1700 sf rambler w/1700 sf unfinished basement and 1088 sf garage and 60 sf covered porch			1997
New	One-story SFR w/basement & attached garage			1997
New	Two Story SFR - 1994 UBC	Plan #RH18		1997
New	Two Story SFR - 1994 UBC	Plan RH31		1997
New	Two Story SFR - 1994 UBC			1997
New	Two Story SFR - 1994 UBC	Plan #RH 78		1997
New	Two Story SFR - 1994 UBC	Plan #RH14		1997
New	Approved Basic #95-106597BP	Two Story SFR - 1994 UBC	(Builders plan #SC06A-94	1997
New	Two Story SFR - 1994 UBC	Plan #RH17		1997
New	Two Story SFR - 1994 UBC	Plan #RH18		1997
New	Two Story SFR - 1994 UBC	Plan #SC12/RH19		1997
New	Approved Basic #97-105807BP	Plan #SC3-B	Two Story SFR - 1994 UBC	1997
New	Two Story SFR w/unfinished basement - 1994 UBC			1997
New	Approved Basic #95-106263BP	Two Story - SFR 1994 UBC	(Builders plan #SC09-94	1997
New	2 story sfr with unfinished basement w/3 car garage			1997
New	Two Story SFR - 1994 UBC			1997
New	Approved Basic #97-107106BP	Plan #RH18	Two Story SFR - 1994 UBC	1997
New	Approved Basic #95-106597BP	Two Story SFR - 1994 UBC	(Builders plan #SC06A-94	1997
New	28x60 (1996) Brookwood			1997
New	NEW SFR-COMBO			1997
New	Approved Basic #96-107790BP	Two Story SFR - 1994 UBC		1997
New	Two Story SFR - 1994 UBC	Plan #2130B		1997
New	New SFR			1997
New	SFR w/finished basement - 1994 UBC			1997
New	Approved Basic #96-106959BP	Plan #2108	Two Story SFR - 1994 UBC	1997
New	SFR/GARAGE/DECK/COVERED DECK			1997
New	2-Story SFR w/attached Garage.			1997
New	Tri Level SFR with attached garage			1997
New	RESIDENCE			1997
New	28 x 46 1990 Liberty			1997
New	2-story SFR w/attached garage			1997
New	Approved Basic #95-106646BP	Plan #2444	Two Story SFR - 1994 UBC	1997
New	Approved Basic #96-102874BP	Plan #2259	Two Story SFR - 1994 UBC	1997
New	Approved Basic #96-106959BP	Plan #2108	Two Story SFR - 1994 UBC	1997
New	Approved Basic #95-106646BP	Plan #2444	Two Story SFR - 1994 UBC	1997
New	Approved Basic #96-106959BP	Plan #2108	Two Story SFR - 1994 UBC	1997
New	Voided by applicant - putting different house on lot	Approved Basic #96-102874BP	Two Story	1997
New	Approved Basic #96-105488BP	Rambler Style SFR - 1994 UBC		1997

Accessory Dwelling Units

Index # - File Name: 1.0022 - Single Family Dwellings Data\_Snohomish County.pdf

New	Approved Basic #95-106646BP	Two Story SFR - 1994 UBC	1997
New	Approved Basic #96-103264BP	Plan #2317 Two Story SFR - 1994 UBC	1997
New	Approved Basic #95-106646BP	Plan #2444 Two Story SFR - 1994 UBC	1997
New	2 Story SFR with attached garage		1997
New	Approved Basic #96-103264BP	Plan #2317 Two Story SFR - 1994 UBC	1997
New	Approved Basic #95-106646BP	Plan #2444 Two Story SFR - 1994 UBC	1997
New	1 Story SFR with attached garage - 1994 UBC		1997
New	Approved Basic #97-102065BP	Rambler Style SFR - 1994 UBC	1997
New	Approved Basic #96-101776BP	SFR w/finished basement - 1994 UBC	1997
New	Approved Basic #97-100480BP	Plan B-2 Two Story SFR - 1994 UBC	1997
New	Approved Basic #97-107561BP	Plan 106.1 Two Story SFR - 1994 UBC	1997
New	Approved Basic #96-109908BP	Plan #7320 Two Story SFR - 1994 UBC	1997
New	Two Story SFR - 1994 UBC	Plan #7340	1997
New	Two Story SFR - 1994 UBC	Plan #105.1.0.	1997
New	Two Story SFR - 1994 UBC	Plan #106.1.0	1997
New	3100 sf 2- Story SFR with attached garage - 1994 UBC	LPG - 500 Gal Tank - 3/5/98	1997
New	Approved Basic #97-111250BP	Plan #101.1.0 Two Story SFR - 1994 UBC	1997
New	Approved Basic #96-109189BP	Plan #7084 Two Story SFR - 1994 UBC	1997
New	Approved Basic #96-109908BP	Plan #7320 Two Story SFR - 1994 UBC	1997
New	Approved Basic #96-109189BP	Plan #7084 Two Story SFR - 1994 UBC	1997
New	2112 sf 2-story w/594 sf garage and 208 sf covered deck/porch		1997
New	Approved Basic #97-102271BP	Plan #103.1 Two Story SFR - 1994 UBC	1997
New	Pending Basic #97-100479BP	Plan 7036 Two Story SFR - 1994 UBC	1997
New	Two Story SFR - 1994 UBC		1997
New	Approved Basic #97-100480BP	Plan B-2 Two Story SFR - 1994 UBC	1997
New	4088 sf 2-story w/956 sf garage		1997
New	2 Story SFR with attached garage	REFERENCE 96-104841-RK FOR PARTIAL SITE REVIEW INFO.	1997
New	2-story SFR with Bsmt & att. Gar.		1997
New	Two Story SFR - 1994 UBC	Plan #94ID/3R	1997
New	2 story with 3 car garage		1997
New	64x40 1996 Silvercrest		1997
New	Rambler w/ 2 car		1997
New	Two-story SFR w/attached garage		1997
New	3218 sq. ft. 2-story w/891 sq. ft. garage and 300sq. ft. covered deck/porch		1997
New	2 story sfr with 3 car garage		1997
New	28 x 60 1990 Fuqua (Log Cabin)		1997
New	Two-story SFR w/attached garage		1997
New	Two-story SFR w/attached garage		1997
New	Two-story SFR w/ attached garage		1997
New	Approved Basic #96-107059BP	(Option Approved Elv. J w/3 car only) Plan #2084 (Elv E - ;	1997
New	1675 sf rambler		1997
New	Two Story SFR with Basement		1997
New	1800 sf 2-story with 864 sf garage and 48 sf covered deck/porch		1997
New	28x52, 1996 Lamplighter Rainier		1997
New	1998 Golden West EE48001F 27 x 48		1997
New	2 Story SFR with attached garage		1997
New	Two Story SFR		1997

Accessory Dwelling Units

Index # - File Name: 1.0022 - Single Family Dwellings Data\_Snohomish County.pdf

New	2-Story SFR w/attached Garage		1997
New	2323 s.f. rambler with 2323 s.f. unfinished basement with 2 car garage		1997
New	Two Story SFR - 1994 UBC		1997
New	2 story SFR w/ garage		1997
New	2 Story SFR with attached garage - 1994 UBC		1997
New	2 Story SFR with attached garage - 1994 UBC		1997
New	Approved Basic #96-107059BP	(Option Approved Elv. J w/3 car only) Plan #2084 (Elv E - 1	1997
New	Two Story SFR with Attached Garage		1997
New	Approved Basic #97-109662BP	Plan #2141 Rambler with attached garage - 1994 UBC	1997
New	2141 sf rambler w/630 sf garage and 52 sf covered porch		1997
New	2 story SFR with fin. basement and attached garage		1997
New	Approved Basic #97-110322BP	Plan #2490 C/3 Two Story SFR - 1994 UBC	1997
New	Approved Basic #97-103738BP	Plan #2084 A/3 Two Story SFR - 1994 UBC C	1997
New	Two Story SFR - 1994 UBC	Plan #205	1997
New	Two Story SFR - 1994 UBC	Plan 405	1997
New	2 story with 3 car garage		1997
New	Two Story SFR - 1994 UBC	Plan 305	1997
New	2 story with 3 car garage		1997
New	Approved Basic #97-103685BP	Plan #K505 Two Story SFR - 1994 UBC	1997
New	Two Story SFR - 1994 UBC	Plan 405	1997
New	Approved Basic #97-103738BP	Plan #2084 A/3 Two Story SFR - 1994 UBC C	1997
New	Approved Basic #97-110322BP	Plan #2490 C/3 Two Story SFR - 1994 UBC	1997
New	Approved Basic #97-103738BP	Plan #2084 A/3 Two Story SFR - 1994 UBC C	1997
New	Two Story SFR - 1994 UBC		1997
New	Approved Basic #96-107059BP	(Option Approved Elv. J w/3 car only) Plan #2084 (Elv E - 1	1997
New	Approved Basic #96-107059BP	(Option Approved Elv. J w/3 car only) Plan #2084 (Elv E - 1	1997
New	Two Story SFR - 1994 UBC		1997
New	Two Story SFR - 1994 UBC		1997
New	Two Story SFR - 1994 UBC	Plan #K2645Y	1997
New	Two story SFR w/attached garage		1997
New	Two Story SFR - 1994 UBC	Plan #2705X	1997
New	2 story SFR w/ garage		1997
New	Two Story SFR - 1994 UBC		1997
New	Two Story SFR - 1994 UBC		1997
New	2 story SFR w/ garage		1997
New	2 Story w/2 car		1997
New	Approved Basic #96-103338BP	Plan #2645 A/B Two Story SFR -1994 UBC	1997
New	Two Story SFR - 1994 UBC		1997
New	Approved Basic #96-103338BP	Plan #2645 A/B Two Story SFR -1994 UBC	1997
New	2140 s.f. duplex		1997
New	1856 sf 2-Story with unfinished basement and attached garage - 1994 UBC		1997
New	Two Story SFR - 1994 UBC	Plan #2645Z	1997
New	2853 sf 2-story w/664 sf garage		1997
New	Two Story SFR - 1994 UBC	Plan #835 M	1997
New	Two Story SFR - 1994 UBC	Plan #126D/3R	1997
New	Approved Basic #96-104687BP	Plan #939B Two Story SFR - 1994 UBC	1997
New	Two Story SFR - 1994 UBC		1997

Accessory Dwelling Units

Index # - File Name: 1.0022 - Single Family Dwellings Data\_Snohomish County.pdf

New	Approved Basic #96-103584BP	Plan 935	Two Story SFR - 1994 UBC	1997
New	2 Story SFR with attached garage			1997
New	*****REFERENCE PREVIOUS PERMIT #272058*****			1997
New	Two Story SFR - 1994 UBC	Plan #926D/3L		1997
New	2305 s.f. rambler			1997
New	2-Story SFR w/attached Garage.			1997
New	Two Story SFR w/unfinished basement - 1994 UBC			1997
New	1997 Skyline Ambercove 27 x 56			1997
New	SFR / GARAGE Application updated 12-15-94			1997
New	One-story duplex w/attached 2-car garages			1997
New	2 Story w/2 car			1997
New	Two Story SFR with Attached Garage			1997
New	28x66, 1997 Oakwood			1997
New	Work cont. on 00-100875.			1997
New	Triple wide (1996) Palm Harbor Mobile Home			1997
New	One-story SFR w/unfin bsmt & attached garage			1997
New	Duplex with garage			1997
New	1997 Palm Harbor 28 x 66			1997
New	Rambler Style SFR - 1994 UBC			1997
New	2176sf 2-story w/278 sf covered deck/porch (no garage)			1997
New	1249 sf SFR with 420 sf attached garage			1997
New	Approved Basic #97-104555BP	Rambler Style SFR - 1994 UBC		1997
New	1255 rambler with 2 car garage			1997
New	Two Story SFR - 1994 UBC			1997
New	2 Story SFR w/ 2 car garage			1997
New	Two Story SFR - 1994 UBC			1997
New	Two Story SFR - 1994 UBC	Plan #RH79		1997
New	Approved Basic #97-108242BP	Plan #RH17	Two Story SFR - 1994 UBC	1997
New	Two Story SFR - 1994 UBC	Plan #RH42		1997
New	Approved Basic #97-107106BP	Plan #RH18	Two Story SFR - 1994 UBC	1997
New	Approved Basic #97-108242BP	Plan #RH17	Two Story SFR - 1994 UBC	1997
New	Two Story SFR - 1994 UBC	Plan #NEW RH91		1997
New	Two Story SFR - 1994 UBC	Plan #LR08		1997
New	Two Story SFR - 1994 UBC	Plan #RH50		1997
New	Two Story SFR - 1994 UBC	Plan #RH018		1997
New	Approved Basic #97-110257BP	Plan #RH50,52	Two Story SFR - 1994 UBC	1997
New	Two Story SFR - 1994 UBC	Plan #RH3-B		1997
New	2 story w/ 3 car			1997
New	One-story SFR w/attached garage			1997
New	SFR with daylight basement and attached garage			1997
New	2498 sf Rambler with attached garage - 1994 UBC			1997
New	2606 sf 2-story w/834 sf garage and 65 sf covered deck/porch			1997
New	2613 sf 2-story w/766 sf garage and 30 sf covered deck/porch			1997
New	Two story SFR w/attached bonus rm over garage			1997
New	Rambler Style SFR - 1994 UBC			1997
New	2-Story SFR w/attached garage			1997
New	Rambler with attached garage and covered porch - 1994 UBC			1997



Accessory Dwelling Units

Index # - File Name: 1.0022 - Single Family Dwellings Data\_Snohomish County.pdf

New	2-Story SFR with attached garage- 1994 UBC	1997
New	New Construction of SFR with 3 car attached garage.	1997
New	Two-story SFR w/attached garage	1997
New	2 story sfr with 3 car garage	1997
New	Approved Basic #96-110262BP Plan 1505 Two Story SFR - 1994 UBC	1997
New	Approved Basic #96-110708BP Rambler Style SFR - 1994 UBC	1997
New	Two Story SFR - 1994 UBC	1997
New	Two Story SFR - 1994 UBC Plan #K400	1997
New	Approved Basic #96-102778BP Rambler Style SFR - 1994 UBC	1997
New	Approved Basic #96-102793BP SFR w/finished basement - 1994 UBC	1997
New	27 X 48 Golden West 1997	1997
New	2-Story SFR w/attached garage (Finaled by D.Brown on 12/5/97)	1997
New	Approved Basic #96-110708BP Rambler Style SFR - 1994 UBC	1997
New	2 story sfr with 3 car garage	1997
New	Approved Basic #96-108573BP Plan 2645/6 A Two Story SFR - 1994 UBC	1997
New	One story SFR w/attached garage	1997
New	Approved Basic #96-103463BP Rambler Style SFR - 1994 UBC	1997
New	28 x 66 1989 Fleetwood	1997
New	2- Story SRF with attached garage - 1994 UBC	1997
New	28 x 66 1997 Skyline	1997
New	Approved Basic #96-103350BP Two Story SFR -1994 UBC	1997
New	Rambler Style SFR - 1994 UBC Plan 1100	1997
New	1678 s.f. rambler with existing garage	1997
New	2 Story with a 2 car	1997
New	2147 sf 2-story w/786 sf garage and 286 sf covered deck/porch	1997
New	2 story with attached garage - 1994 UBC	1997
New	Daylight rambler w 2 car	1997
New	2 story sfr with 2 car garage.	1997
New	Approved Basic #96-107638BP Option Approved for Elevation B Two Story SFR - 1994 U	1997
New	1821 sf 2-story w/432 sf garage and 100 sf covered deck/porch	1997
New	Approved Basic #96-109525BP Plan #LC969 Two Story SFR - 1994 UBC	1997
New	Approved Basic #96-109525BP Plan #LC969 Two Story SFR - 1994 UBC	1997
New	Approved Basic #96-109525BP Plan #LC969 Two Story SFR - 1994 UBC	1997
New	Approved Basic #95-110380BP SFR w/finished or unfinished basement - 1994 UBC	1997
New	1386 sf rambler with 2 car garage	1997
New	1304 sf rambler w/658 sf finished basement & 590 sf garage and 35 sf covered deck/porch	1997
New	24x48, 1994 Marlette Northerner	1997
New	Two Story SFR with daylighted and attached garage - 1994 UBC 8-8-97 Applicant(AI Beckstrom)	1997
New	Approved Basic #96-102793BP SFR w/finished basement - 1994 UBC	1997
New	Split level w/2 car - 1994 UBC	1997
New	Approved Basic #96-109525BP Plan #LC969 Two Story SFR - 1994 UBC	1997
New	Approved Basic #96-109525BP Plan #LC969 Two Story SFR - 1994 UBC	1997
New	SFR	1997
New	2- Story SFR with attached garage - 1994 UBC	1997
New	Approved Basic #96-109525BP Plan #LC969 Two Story SFR - 1994 UBC	1997
New	Approved Basic #96-109525BP Plan #LC969 Two Story SFR - 1994 UBC	1997
New	Approved Basic #96-102793BP SFR w/finished basement - 1994 UBC	1997

Accessory Dwelling Units

Index # - File Name: 1.0022 - Single Family Dwellings Data\_Snohomish County.pdf

New	Approved Basic #96-102781BP	Rambler Style SFR - 1994 UBC	1997
New	Approved Basic #96-102793BP	SFR w/finished basement - 1994 UBC	1997
New	2348 sf 2-story w/510 sf garage		1997
New	23330 sf SFR with attached garage - 1994 UBC		1997
New	28 x 44 Double Wide 1996 Golden West		1997
New	Approved Basic #96-107059BP	Plan #2084 (Elv E - 2 car only) Two Story SFR - 1994 UBC	1997
New	Two Story SFR - 1994 UBC	Plan #2165T-A/2 (Finaled by D.Erichsen on 12/3/97)	1997
New	2 story SFR w/ garage		1997
New	2 Story w/2 Car		1997
New	3024 sf 2-story w/892 sf finished basement, 768 sf garage, and 420 sf covered deck/porch		1997
New	Approved Basic #96-107059BP	Plan #2084 (Elv E - 2 car only) Two Story SFR - 1994 UBC	1997
New	2 story sfr with basement and 3 car garage.		1997
New	28 x 56 Mobile Home. EXPIRED W/O FINAL. REF. 00-108230.		1997
New	2212 sf 2-story with 708 sf garage		1997
New	1745 sf 2-story SFR with 528 sf attached garage		1997
New	extended to 12/5/97		1997
New	Two Story Duplex - 1994 UBC		1997
New	One story SFR w/attached garage		1997
New	2 Story SFR with attached garage - 1994 UBC		1997
New	Approved Basic #95-106587BP	0 LOT LINE STRUCTURE Two Story SFR (1994 UBC)	1997
New	Approved Basic #96-101920BP	0 LOT LINE STRUCTURE Two Story SFR - 1994 UBC	1997
New	Approved Basic #96-101920BP	0 LOT LINE STRUCTURE Two Story SFR - 1994 UBC	1997
New	Approved Basic #95-106587BP	0 LOT LINE STRUCTURE Two Story SFR (1994 UBC)	1997
New	Approved Basic #95-106587BP	0 LOT LINE STRUCTURE Two Story SFR (1994 UBC)	1997
New	Approved Basic #96-101911BP	0 LOT LINE STRUCTURE Two Story SFR - 1994 UBC	1997
New	Approved Basic #95-106583BP	0 LOT LINE STRUCTURE Two Story SFR (1994 UBC)	1997
New	Approved Basic #95-106587BP	0 LOT LINE STRUCTURE Two Story SFR (1994 UBC)	1997
New	Approved Basic #95-106587BP	0 LOT LINE STRUCTURE Two Story SFR (1994 UBC)	1997
New	Approved Basic #96-101920BP	0 LOT LINE STRUCTURE Two Story SFR - 1994 UBC	1997
New	Approved Basic #95-106583BP	0 LOT LINE STRUCTURE Two Story SFR (1994 UBC)	1997
New	Approved Basic #95-106587BP	0 LOT LINE STRUCTURE Two Story SFR (1994 UBC)	1997
New	Approved Basic #95-106587BP	0 LOT LINE STRUCTURE Two Story SFR (1994 UBC)	1997
New	Approved Basic #96-101920BP	0 LOT LINE STRUCTURE Two Story SFR - 1994 UBC	1997
New	Approved Basic #96-101911BP	0 LOT LINE STRUCTURE Two Story SFR - 1994 UBC	1997
New	Approved Basic #95-106587BP	0 LOT LINE STRUCTURE Two Story SFR (1994 UBC)	1997
New	Approved Basic #95-106587BP	0 LOT LINE STRUCTURE Two Story SFR (1994 UBC)	1997
New	Approved Basic #95-106586BP	0 LOT LINE STRUCTURE Two Story SFR (1994 UBC)	1997
New	Approved Basic #96-101920BP	0 LOT LINE STRUCTURE Two Story SFR - 1994 UBC	1997
New	Approved Basic #95-106587BP	0 LOT LINE STRUCTURE Two Story SFR (1994 UBC)	1997
New	Approved Basic #95-106587BP	0 LOT LINE STRUCTURE Two Story SFR (1994 UBC)	1997
New	Approved Basic #96-101911BP	0 LOT LINE STRUCTURE Two Story SFR - 1994 UBC	1997
New	Approved Basic #96-101920BP	0 LOT LINE STRUCTURE Two Story SFR - 1994 UBC	1997
New	Approved Basic #96-101920BP	0 LOT LINE STRUCTURE Two Story SFR - 1994 UBC	1997
New	Approved Basic #96-101911BP	0 LOT LINE STRUCTURE Two Story SFR - 1994 UBC	1997
New	Approved Basic #96-101920BP	0 LOT LINE STRUCTURE Two Story SFR - 1994 UBC	1997
New	Approved Basic #96-101920BP	0 LOT LINE STRUCTURE Two Story SFR - 1994 UBC	1997
New	Approved Basic #96-101911BP	0 LOT LINE STRUCTURE Two Story SFR - 1994 UBC	1997



Accessory Dwelling Units

Index # - File Name: 1.0022 - Single Family Dwellings Data\_Snohomish County.pdf

New	Approved Basic #95-106587BP	0 LOT LINE STRUCTURE	Two Story SFR	(1994 UBC)	1997
New	Approved Basic #95-106587BP	0 LOT LINE STRUCTURE	Two Story SFR	(1994 UBC)	1997
New	Approved Basic #95-106583BP	0 LOT LINE STRUCTURE	Two Story SFR	(1994 UBC)	1997
New	Approved Basic #95-106583BP	0 LOT LINE STRUCTURE	Two Story SFR	(1994 UBC)	1997
New	Approved Basic #95-106587BP	0 LOT LINE STRUCTURE	Two Story SFR	(1994 UBC)	1997
New	Approved Basic #95-106587BP	0 LOT LINE STRUCTURE	Two Story SFR	(1994 UBC)	1997
New	Approved Basic #96-101920BP	0 LOT LINE STRUCTURE	Two Story SFR - 1994 UBC		1997
New	Approved Basic #95-106586BP	0 LOT LINE STRUCTURE	Two Story SFR	(1994 UBC)	1997
New	Approved Basic #95-106587BP	0 LOT LINE STRUCTURE	Two Story SFR	(1994 UBC)	1997
New	Approved Basic #96-101920BP	0 LOT LINE STRUCTURE	Two Story SFR - 1994 UBC		1997
New	Approved Basic #96-101920BP	0 LOT LINE STRUCTURE	Two Story SFR - 1994 UBC		1997
New	Approved Basic #95-106586BP	0 LOT LINE STRUCTURE	Two Story SFR	(1994 UBC)	1997
New	Approved Basic #96-101920BP	0 LOT LINE STRUCTURE	Two Story SFR - 1994 UBC		1997
New	Approved Basic #96-101920BP	0 LOT LINE STRUCTURE	Two Story SFR - 1994 UBC		1997
New	Approved Basic #96-101911BP	0 LOT LINE STRUCTURE	Two Story SFR - 1994 UBC		1997
New	Approved Basic #95-106583BP	0 LOT LINE STRUCTURE	Two Story SFR	(1994 UBC)	1997
New	Approved Basic #95-106587BP	0 LOT LINE STRUCTURE	Two Story SFR	(1994 UBC)	1997
New	1997 single wide Fleetwood Mobile Home				1997
New	32x60 (1997) Fleetwood				1997
New	Approved Basic 96-101522-001BP	2 Story with a 3 car	Plan 6220 W/Bonus		1997
New	Approved Basic 96-101522-002BP	2 Story with a 3 car	Plan 6220 W/O Bonus		1997
New	Approved Basic #96-101526-002BP	2 Story with a 3 car	Plan 6210 W/ Bonus		1997
New	Approved Basic #96-101526-002BP	Two Story SFR - 1994 UBC		Plan #6210 w	1997
New	Approved Basic #96-101520-003BP	2 Story with a 3 car	Plan # 6230 B W/ Bonus		1997
New	Approved Basic 96-101522-001BP	2 Story with a 3 car	Plan 6220 W/Bonus		1997
New	Approved Basic #96-101520-003BP	2 Story with a 3 car	Plan # 6230 B W/ Bonus		1997
New	24 x 56 MH - 1980 Sequoia				1997
New	2 story w/2 car				1997
New	2068 sf 2-story with 476 sf garage and 30sf covered porch				1997
New	2540 sf Rambler w/576 sf garage				1997
New	2386 sf Rambler w/635 sf garage				1997
New	2-Story SFR w/3-car attached garage.				1997
New	Rambler with attached Garage				1997
New	Approved Basic #97-110030BP	Plan #9506	Two Story SFR - 1994 UBC		1997
New	Hat Island vacation home File 95-106574 000 01 created to correct missing renewal. Fees paid				1997
New	One-story w/fin bsmt & attached garage				1997
New	Rambler Style SFR w/attached garage				1997
New	27x60 (1997) Golden West				1997
New	24 x 64 - 1978 Port Royal				1997
New	1996 28 x 68 Marlette				1997
New	Two Story SFR - 1994 UBC				1997
New	Approved Basic #96-110432BP	Two Story SFR - 1994 UBC		Plan #081788	1997
New	2-Story SFR - 1994 UBC				1997
New	1904 sf 2-story w/462 sf garage, 1150 sf finished basement and 30 sf covered deck/porch				1997
New	2-Story SFR with attached garage - 1994 UBC				1997
New	2-Story SFR w/attached Garage (Finaled by D.Brown on 12/4/97)				1997
New	Approved Basic #97-105382BP	Plan 2032	Two-story SFR - 1994 UBC		1997

Accessory Dwelling Units

Index # - File Name: 1.0022 - Single Family Dwellings Data\_Snohomish County.pdf

New	Approved Basic #96-100749BP	Plan #1618 SFR w/finished basement - 1994 UBC	1997
New	Approved Basic #97-105382BP	Plan 2032 Two-story SFR - 1994 UBC	1997
New	Approved Basic 95-107925BP	(Builders Plan #1740) Two Story SFR - 1994 UBC	1997
New	Approved Basic #97-105439BP	Plan #1557 Rambler Style SFR - 1994 UBC	1997
New	Approved Basic #97-105382BP	Plan 2032 Two-story SFR w/attached garage	1997
New	2 story SFR with 2 car garage		1997
New	Two-story SFR w/attached garage		1997
New	2 story sfr with 3 car garage		1997
New	3093 sf rambler w/2016 sf finished basement and 192 sf covered porch		1997
New	Split level entry SFR with attached garage		1997
New	1330 sf rambler w/420 sf garage		1997
New	Rambler style with attached garage.		1997
New	Two Story SFR - 1994 UBC	Plan #1895	1997
New	Approved Basic #97-101148BP	Plan #1365 Rambler Style SFR - 1994 UBC	1997
New	SFR w/finished basement - 1994 UBC		1997
New	SFR w/finished basement - 1994 UBC		1997
New	Rambler w/2 car		1997
New	NEW CONTRACTOR: MALLARD HOMES	Rambler Style SFR - 1994 UBC	1997
New	NEW CONTRACTOR: MALLARD HOMES	Rambler Style SFR w/attached Garage (0-Lot Line)	1997
New	Approved Basic #97-108760BP	Plan #1150 Rambler Style - 1994 UBC	1997
New	Approved Basic #97-108760BP	Plan #1150 Rambler Style - 1994 UBC	1997
New	Approved Basic #97-108760BP	Plan #1150 Rambler Style - 1994 UBC	1997
New	Approved Basic #97-108760BP	Plan #1150 Rambler Style - 1994 UBC	1997
New	Approved Basic #97-108760BP	Plan #1150 Rambler Style - 1994 UBC	1997
New	Approved Basic #97-108760BP	Plan #1150 Rambler Style - 1994 UBC	1997
New	1815 sq. ft. 2-story w/576 sq. ft. garage		1997
New	Rambler Style SFR - 1994 UBC		1997
New	Rambler w/3 car		1997
New	Two Story Duplex - 1994 UBC		1997
New	Approved Basic #95-110380BP	SFR w/finished or unfinished basement - 1994 UBC	1997
New	1998 27 x 66 Palm Harbor		1997
New	27x56 1997 Golden West		1997
New	56 X 28 Redmond 1997		1997
New	1701 sf 2-story, w/800 sf basement, 460 sf garage, and 36 sf covered porch		1997
New	Split Level with attached garage - 1994 UBC		1997
New	28x52, 1997 Palm Harbor		1997
New	28 x 60 Doublewide Mobile Home		1997
New	66x27 (1997) Northwest 66000IF Golden West - Temp Dwelling MH		1997
New	SFR with attached garage - 1994 UBC		1997
New	12 x 55 Mobile Home		1997
New	SFR - Replacing Burned SFR Structure in Same Footprint		1997
New	SFR / COVERED DECK		1997
New	24 x 55 Capewood		1997
New	25x56 1997 Fleetwood		1997
New	6 YEAR FOREST PRACTICES MORATORIUM FROM 8-28-97 TILL 8-28-2003	2-Story SFR (FINALED)	1997
New	28x66, 1989 Barrington		1997
New	28 x 48 1996 Lamplighter		1997

Accessory Dwelling Units

Index # - File Name: 1.0022 - Single Family Dwellings Data\_Snohomish County.pdf

New	14 x 70 singlewide Oakwood MH	1997
New	Two- story SFR w/attached garage	1997
New	SFR w/300 sf loft & full unfin basement	1997
New	2-Story SFR	1997
New	12 X 50 HACL 1968	1997
New	27 x 56 - 1997 - Palm Harbor	1997
New	1470 sf one-story SFR	1997
New	Guesthouse w/3 car garage	1997
New	28 x 66 Palm Harbour #1067	1997
New	2-Story SFR	1997
New	1850 sf Rambler with 780 s.f. 2 car garage	1997
New	14 x 70 Marlet, 70/14 single wide 1979 Mobile Home	1997
New	Rambler with Attached Garage	1997
New	27 x 56 1997 Palm Harbor 6 YEAR FOREST PRACTICES MORATORIUM FROM 9/2/94 THROUGH	1997
New	14x70, 1976 Four Seasons	1997
New	56x27 (1996) NW Limited	1997
New	626 sf accessory apt w/ 3 car garage	1997
New	MH Permit for Title Elimination	1997
New	27 X 59 Palm Harbor 1997	1997
New	66 x 40 1997 Golden West Triple Wide	1997
New	2 story sfr with unfinished basement and 3 car garage	1997
New	Approved Basic #97-103280BP Plan #1400 SFR w/finished basement - 1997	1997
New	27x56 (1997) Golden West existing on site	1997
New	Per letter from Frances Sykes, ownership transferred to Mark & Janet Watke, 7/14/97.	1997
New	2 Story with basement and 3 car	1997
New	28x60 (1990) Fleetwood	1997
New	SFR w/finished basement - 1994 UBC	1997
New	Split Level SFR with attached garage - 1994 UBC	1997
New	REF PERMIT 97-105941 RK Converting portion of storage bldg. into SFR Two story - 1994 UBC	1997
New	Approved Basic #97-102065BP Plan #1797 Rambler Style SFR - 1994 UBC	1997
New	Approved Basic #96-100779BP Two Story SFR - 1994 UBC	1997
New	Rambler style SFR w/attached garage ref FP2800286 which must be changed to Class IV Conver	1997
New	Split Level SFR with garage	1997
New	Two-story SFR w/finished basement & attached garage	1997
New	12x66, 1986 American Mansion	1997
New	2208 sf Single Story SFR with 2976 sf attached garage - 1994 UBC	1997
New	26 8 X 66 8 Marlette Brookwood 1997	1997
New	see comments 5-18-99	1997
New	2-Story SFR w/attached garage 6-26-97 Applicant changed plans from LPG forced air to Electric	1997
New	40x62, 1997 Palm Harbor, Triple-wide	1997
New	27x52 (1997) Winterhaven II	1997
New	Two story SFR	1997
New	27 x 52 (1997) Goldenwest	1997
New	1983 14 X 66 Fleetwood	1997
New	24 x 52 - 1979 Ridgewood Mobile Home	1997
New	64 x 24 1978 Silver Crest	1997
New	40x66 1997 Pacifica	1997

Accessory Dwelling Units

Index # - File Name: 1.0022 - Single Family Dwellings Data\_Snohomish County.pdf

New	Rambler w/daylight bsmt	1997
New	1997 Golden West Winterhaven 27 x 56	1997
New	2 story sfr with basement	1997
New	2- Story SFR with attached garage - 1994 UBC	1997
New	56 x 27 (1996) Jackson #1057	1997
New	1997 Skyline AmerCove 42 x 56	1997
New	14 x 70 (1979) Statler	1997
New	27x56, 1997 Palm Harbor	1997
New	Mobile Home	1997
New	14 x 70 - 1974 Glenbrook MH - Rev-8/20/96	1997
New	Split level w/2 car -1994 UBC	1997
New	52x27 (1991) Goldenwest Winterhaven	1997
New	Rambler style SFR w/attached garage	1997
New	One-story SFR w/unfin. bsmt & attached garage	1997
New	Split level w/unfin bsmt & attached garage	1997
New	Rambler w/2 car	1997
New	24x60, 1979 Kentwood	1997
New	2 story cabin	1997
New	28x44, 1997 Goldenwest	1997
New	Approved Basic #97-108480BP Plan 1530/2 Two-story SFR w/attached garge	1997
New	24 x 56 (1979) Kentwood-Princeton	1997
New	Double Wide Mobile	1997
New	27 x 66 (1997) Fleetwood	1997
New	1996 28 x 66 Marlett	1997
New	432 sq. ft. Accessory Apt.	1997
New	14 x 70 Mobile Home	1997
New	Two Story SFR with attached Garage	1997
New	3050 sf 2-story w/556 sf garage and 240 sf open deck	1997
New	Rambler w/ 2 car	1997
New	Rambler Style SFR - 1994 UBC	1997
New	Approved Basic #95-110737BP Rambler Style SFR - 1994 UBC	1997
New	Approved Basic #97-103997BP Plan #G120393 Rambler Style SFR - 1994 UBC	1997
New	Approved Basic #95-110737BP Rambler Style SFR - 1994 UBC	1997
New	1342 sf rambler w/462 sf garage and 130 sf covered porch	1997
New	Rambler Style SFR w/attached garage	1997
New	1767 sf 2-story w/385 sf attached garage	1997
New	1467 sf 2-story w/385 sf attached garage	1997
New	Approved Basic #97-110975BP Rambler Style SFR - 1994 UBC	1997
New	1204 s.f. rambler with 2 car garage	1997
New	1186 SF Rambler with attached garage	1997
New	Rambler with attached garage and covered porch - 1994 UBC	1997
New	Rambler with attached garage and covered porch - 1994 UBC	1997
New	2-Story SFR	1997
New	1160 sq. ft. rambler w/285 sq. ft garage and 24 sq. ft. covered porch	1997
New	1186 sf Rambler w/attached garage	1997
New	SFR with Unfinished Basement and Garage	1997
New	Approved Basic #97-110188BP Plan #1031 C Split level SFR with attached garage	1997

Accessory Dwelling Units

Index # - File Name: 1.0022 - Single Family Dwellings Data\_Snohomish County.pdf

New	Approved Basic #97-103997BP	Plan# G120393	Rambler Style SFR - 1994 UBC	1997
New	Approved Basic #95-110737BP		Rambler Style SFR - 1994 UBC (Finaled by A.Husby)	1997
New	Two Story SFR			1997
New	2 Story SFR - 1994 UBC			1997
New	1099 SF Rambler with attached garage			1997
New	1344 sf 3 bedroom rambler with attached garage - 1994 UBC			1997
New	Approved Basic #95-110737BP		Rambler Style SFR - 1994 UBC	1997
New	1090 sf rambler w/440 sf garage			1997
New	2 story w/2 car			1997
New	Approved Basic 97-100791BP		Rambler Style SFR - 1994 UBC	1997
New	1997 Guedon 28 x 48			1997
New	28 x 48 1992 Waverly Crest Double Wide Mobile Home.			1997
New	1672 sf SFR with 552 attached garage.			1997
New	Approved Basic 97-100518BP	Plan #1683	Split Level SFR- 1994 UBC 3/17/97 - (	1997
New	Rambler with Attached Garage			1997
New	1320 sf Rambler with 452 sf garage			1997
New	2-Story SFR w/attached garage			1997
New	Approved Basic #97-103533BP		SFR w/unfinished & unheated lower floor - 1994 UBC	1997
New	Approved Basic #97-103533BP		SFR w/unfinished & unheated lower floor - 1994 UBC	1997
New	Approved Basic #95-110380BP	Plan #1283	SFR w/finished or unfinished ba	1997
New	Approved Basic #95-110380BP	Plan #1283	SFR w/finished or unfinished ba	1997
New	Approved Basic #95-110380BP	Plan #1283	SFR w/finished or unfinished ba	1997
New	1997 Marlette			1997
New	Approved Basic #96-102594BP		Rambler Style SFR - 1994 UBC	1997
New	Two Story SFR			1997
New	27 x 40 Mobile Home			1997
New	Two Story SFR			1997
New	2-Story SFR w/unfin. basement/garage			1997
New	Two Story Duplex - 1994 UBC			1997
New	40 x 56 Triplewide 1997 Fleetwood (Finaled by C.Koch on 12/5/97)			1997
New	1200 sf rambler w/528 sf garage, 360 sf carport and 160 sf covered deck/porch			1997
New	1804 Rambler - 1994 UBC			1997
New	2 story SFR with attached garage			1997
New	1950 sf Rambler with 1440 sf attached garage & 324 sf covered porch			1997
New	2770 sf 2-story DUPLEX w/960 sf garage and 40 sf covered deck/porch			1997
New	2-Story Duplex			1997
New	38.5 x 60 - 1996 Fleetwood			1997
New	Two-story SFR w/attached garage			1997
New	2 story SFR			1997
New	This is a mobile home permit to reinstate expired permit 267470. (6-mo. notice mailed 2/97)			1997
New	Approved Basic #95-110380BP		SFR w/finished or unfinished basement - 1994 UBC	1997
New	Approved Basic #95-110380BP	Plan #1283	SFR w/finished or unfinished ba	1997
New	3040 sf 2-story w/1140 sf garage and 300 sf carport			1997
New	2 story w/2 car			1997
New	14 x 66 (1986) Skyline/Oakhaven			1997
New	SFR 3/10/99 - OK to renew per Gloria Baker			1997
New	28x52 (1997) Palm Harbour			1997



Accessory Dwelling Units

Index # - File Name: 1.0022 - Single Family Dwellings Data\_Snohomish County.pdf

New	SFR w/ basement	1997
New	12 x 60 - 1973 Kentwood Mobile Home.	1997
New	14 x 66 1980 Fleetwood Commander	1997
New	20x66 1964 Liberty Peerless	1997
New	Two-story SFR	1997
New	Rambler style SFR w/attached Garage	1997
New	1826 sf SFR with attached garage - 1994 UBC *****Contrator changed to: HIS Home Imp	1997
New	Approved Basic #97-100722BP Plan #2416 Two Story SFR - 1994 UBC	1997
New	Approved Basic #96-108624BP Plan #1365 SFR w/finished basement - 1994 UBC	1997
New	Two Story SFR with Attached Garage	1997
New	2-Story SFR with attached Garage/shop	1997
New	2 Story SFR w/attached garage	1997
New	Approved Basic #96-101623BP Two Story SFR - 1994 UBC	1997
New	1997 - 40 x 66 Golden West Mobile Home.	1997
New	28 X 66 Lamplighter 1996	1997
New	SFR with daylight basement	1997
New	2 Story w/2 car	1997
New	1247 sq. ft. SFR w/576 sqw. ft. finished basement and 517 sq,. ft, garage	1997
New	1997 Golden West Country Estate (66 x 40)	1997
New	Two Story SFR (Finaled by H.Reeves on 7-9-97.)	1997
New	Mobile Home, 39 -10 X 66 - 8 - 1997 Silver Crest	1997
New	Two Story SFR w/tower - 1994 UBC	1997
New	25 X 56 Hickory Hill 1997	1997
New	24 x 62 - 1976 Hillcrest Homette	1997
New	2 story sfr with 2 car garage	1997
New	Rambler Style SFR - 1994 UBC	1997
New	sfr w/ garage	1997
New	One story SFR replacing existing SFR same site. (Finaled 12/8/97 by A.Husby) 8-14-97 changed	1997
New	Daylight Basement Rambler	1997
New	SFR w/unfinished basement - 1994 UBC Plan #1415	1997
New	3126 sf 2-story w/1520 sf finished basement and 716 sf covered deck/porch	1997
New	2 story with 3 car attached garage.	1997
New	SFR w/unfinished basement - 1994 UBC Plan #1415	1997
New	Approved Basic #97-106573BP Plan #2409 T/3 Two Story SFR - 1994 UBC	1997
New	Two Story SFR with Attached Garage	1997
New	1820 s.f. rambler with 3 car garage	1997
New	2 Story w/3 car	1997
New	52 x 24 1980 Skyline (Reference Expired Permit #4052)	1997
New	1976 Titan 14 x 66.	1997
New	2 story sfr with basement and 2 car garage	1997
New	2 story sfr with unfinished basement & 3 car garage	1997
New	Approved Basic 97-100109BP Plan #1248 w/front or side entry garage Two Story SFR - 1994	1997
New	Approved Basic 97-100109BP Plan #1248 w/front or side entry garage Two Story SFR - 1994	1997
New	Two-story SFR w/ attached garage	1997
New	27.6x66, 1997 Liberty	1997
New	28 x 66 (1978) - Golden Sunrise	1997
New	24x56 1977 Camelot	1997

Accessory Dwelling Units

Index # - File Name: 1.0022 - Single Family Dwellings Data\_Snohomish County.pdf

New	1996 44 x 25 Fleetwood change to 1975 Hillcrest 48x24	1997
New	Two Story Duplex - 1994 UBC	1997
New	1549 sf One-story w/1524 sf unfinished bsmt & 533 sf attached garage	1997
New	1549 SF Rambler with attached garage	1997
New	1530 sf Rambler with 1390 Daylight Basement and 480 sf garage	1997
New	Approved Basic #97-107334BP Split Level SFR w/unfinished lower floor - 1994 UBC	1997
New	One-story SFR w/full unfin basement-no garage.	1997
New	1977 Concord Mobile Home 24 x 40	1997
New	SFR	1997
New	2717 sf Rambler with attached garage - 1994 UBC	1997
New	Two Story SFR - 1994 UBC	1997
New	2 Story w/3 Car	1997
New	2 Story w/basement & 3 car	1997
New	2 Story w/basement & 3 car. Also see MO permit 97-103940	1997
New	Approved Basic 97-109761BP Plan 2718-B One-story SFR w/3-car attach	1997
New	3105 sf SFR w/790 sf garage	1997
New	2 story sfr with 3 car garage. CLOSED W/O FINAL. CERT. OF NON-COMPLIANCE ISSUED 1/14/02	1997
New	24 x 60 - 1977 Peerless Mobile Home	1997
New	Approved Basic #96-103350BP Two Story SFR -1994 UBC	1997
New	27 - 4 x 66 - 1978 Frontier Mobile Home.	1997
New	2 story sfr	1997
New	2117 sf SFR with 678 sf Attached garage	1997
New	Rambler style SFR w/unfin. basement & covered porch + deck.	1997
New	Accessory apartment with detached garage	1997
New	SFR with Second Story Loft	1997
New	28x66, 1997 Marlette (Finaled by H.Reeves on 12/9/97)	1997
New	Convert existing garage into SFR. Renewal of 257331 (aka 91-132544-RK)	1997
New	2 story sfr with 2 car garage	1997
New	Single Wide Mobile Home	1997
New	DUPLEX	1997
New	1664 sf rambler w/990 sf garage and 71.5 sf covered deck/porch	1997
New	Single Story SFR with Loft and Basement	1997
New	2 story sfr with unfinished basement and 3 car garage	1997
New	SFR	1997
New	40x48-- 1997 Marlette	1997
New	2 story w/2 car	1997
New	28 X 66 Marlette 1997	1997
New	2 story w/3 car SFR	1997
New	14 x 68 (1974) Lamplighter	1997
New	2-Story SFR w/attached garage.	1997
New	24 x 60 Mobile Home as GUEST HOUSE.	1997
New	600 sf rambler (no garage)	1997
New	2 Story w/3 car	1997
New	2 Story (Room above garage is for storage only says Inspector Palmer.)	1997
New	Replacing existing home with 2 story sfr.	1997
New	27 x 50 1996-Golden West Mobile Home.	1997
New	24 x 44 1997 Fleetwood	1997

Accessory Dwelling Units

Index # - File Name: 1.0022 - Single Family Dwellings Data\_Snohomish County.pdf

New	28x54, 1997 Westwind	1997
New	2 story SFR with attached garage - 1994 - UBC -- (Reconstruction from foundation up due to fi	1997
New	3592 sf SFR with 1116 sf basement and 884 sf attached garage replacing SFR which was destro	1997
New	2 Story & 3 car garage	1997
New	Approved Basic #96-105880BP Two Story SFR - 1994 UBC	1997
New	1375 sf Rambler w/420 sf garage and 96 sf covered porch	1997
New	1325 sf SFR with attached garage and covered porch - 1994 UBC	1997
New	2 story Log home w/basement	1997
New	14 x 52 Kentwood 1982 Disturbance on slopes greater than 25%. Disturbance within 65 ft. of f	1997
New	2- Story with finished daylighted basement and attached garage - 1994 UBC	1997
New	Rambler Style SFR - 1994 IBC	1997
New	2 Story SFR	1997
New	Two Story Duplex 1994 UBC	1997
New	1977 Fleetwood 14 X 66	1997
New	1977 14 x 60 Governor MH	1997
New	Rambler w/bsmt & 2 car	1997
New	2192 SF Rambler with attached garage	1997
New	Split level SFR w/attached garage Finaled by T. Bryant on 12/3/97	1997
New	24 X 60 Titan 1978 for Title Elimination	1997
New	56 x 27 Fleetwood 1997	1997
New	Approved Basic #97-110224 BP Two Story SFR - 1994 UBC	1997
New	Approved Basic #96-103350BP Two Story SFR -1994 UBC	1997
New	2 story SFR with unfinished basement	1997
New	2-Story with attached garage - 1994 UBC	1997
New	Two Story - SFR with Attached Garage	1997
New	SFR - Rambler with attached garagge	1997
New	Two-story SFR. Total rebuild after fire, using existing foundation.	1997
New	14 x 66 Broadmore 1976 Mobile Home	1997
New	28 x 52 1997 Goldenwest NW Limited Doublewide	1997
New	Two SFR w/finished basement - 1994 UBC	1997
New	2-Story over daylight basement SFR	1997
New	60x24 (1977) Candlewood	1997
New	2076 sf 2-story w/441 sf attatched garage	1997
New	2-Story SFR with attached garage - 1994 UBC	1997
New	1542 sf 2- Story SFR with 400 sf coverd deck - 1994 UBC (Finaled 12/9/97 by N.Overland)	1997
New	2 story w/2 car	1997
New	16x44 (1970) Safeway	1997
New	10x50 (1970) Columbia	1997
New	28x66, 1997 Marlette	1997
New	Two Story w/basement SFR - 1991 UBC	1997
New	Rambler with attached garage - 1994 UBC	1997
New	2333 sf Rambler w/1390 sf basement, 780 sf garage and 168 sf covered deck/porch	1997
New	2 story SFR -	1997
New	1880 s.f. Rambler with 2 car garage	1997
New	40x56 Marlette (Pacifica) 1997	1997
New	4318 sq. ft. 2-story	1997
New	2 Story SFR w/ garage	1997

Accessory Dwelling Units

Index # - File Name: 1.0022 - Single Family Dwellings Data\_Snohomish County.pdf

New	1506 sf Rambler w/661 sf finished basement and 520 sf garage		1997
New	SFR		1997
New	2255 sf Rambler w/1125 sf unfinished basement, 754 sf garage and 82 sf covered porch		1997
New	SFR with Daylight Basement		1997
New	1981 Fleetwood (14 x 60)		1997
New	2 story w/ 3 car		1997
New	Rambler style SFR w/attached garage		1997
New	2 Story with attached garage - 1994 UBC		1997
New	2 story sfr with 3 car garage		1997
New	Two Story SFR. (See also: 95-104825)		1997
New	Approved Basic #97-105227BP	Builders #1024 Rambler with attached ga	1997
New	1241 sf 2-story GUESTHOUSE		1997
New	2-Story SFR w/attached Garage		1997
New	27 x 66 Double Wide 1997 MH ( Palm Harbor) - 1994 UBC		1997
New	Palm Harbor, The Jackson #1057 28x56 (1997) #1057		1997
New	2-Story SFR w/unfin. Basement & Attached Garage		1997
New	Two Story SFR - 1994 UBC 6-10-97 Applicant came in for 1 each extra gas piping and to change		1997
New	14x70 (1979) Skyline		1997
New	26 x 66 Mobile Home		1997
New	Two Story SFR with attached Garage		1997
New	14 x 66 , 1973, Fleetwood		1997
New	31 X 48 2 Story Duplex		1997
New	2 story w/bsmt & 1/car w RV Space		1997
New	Detached accessory apartment, garage & storage		1997
New	2 Story SFR with attached garage - 1994 UBC	Plan #2431	1997
New	26 x 66 with 10 x 37 bumpout 1995 Barrington		1997
New	SFR		1997
New	2 Story SFR w/attached Garage.		1997
New	SFR		1997
New	Two Story SFR - 1994 UBC		1997
New	28 x 70 1980 Sky Mobile Home		1997
New	1997 Doublewide 27 x 48 Oakwood		1997
New	Two Story SFR		1997
New	14 x 66 1979 Singlewide Shelby/Commadore		1997
New	1981 14 x 70 - Sandpoint		1997
New	Rambler w/2 car		1997
New	Approved Basic #96-109846BP	Plan 2330D/3 Two Story SFR - 1994 UBC	1997
New	2097 s.f. sfr with 1064 s.f. unfinished basement & 2-car garage		1997
New	2019 sf Rambler w/870 sf garage and 180 sf covered deck/porch (Finaled by R.Walker on 12/4)		1997
New	14x70 (1975) Gentry		1997
New	2- story SFR with attached garage - 1994 UBC		1997
New	Rambler w/3 car		1997
New	Two-story SFR w/attached garage		1997
New	Split Entry SFR w/garage.		1997
New	Split Entry SFR w/garage		1997
New	Rambler with Attached Garage		1997
New	Two Story SFR - 1994 UBC	Plan #2379	1997

Accessory Dwelling Units

Index # - File Name: 1.0022 - Single Family Dwellings Data\_Snohomish County.pdf

New	Split level SFR - 1994 UBC	Plan #020792	1997
New	Approved Basic #96-105448BP	Two Story SFR - 1994 UBC	1997
New	Two Story SFR - 1994 UBC	Plan #1934-A	1997
New	Rambler with attached garage - 1994 UBC		1997
New	2-Story SFR w/attached Garage		1997
New	Approved Basic #97-1055768BP	Rambler Style Duplex - 1994 UBC	1997
New	2 story SFR		1997
New	10x52 w/tipout - 1965		1997
New	1260 sf 2-story w/156 sf covered deck porch		1997
New	Two Story SFR with Attached Garage		1997
New	Approved Basic #97-110376BP	Rambler Style SFR w/attached garage Bldrs. Plan #2201-R	1997
New	Approved Basic #97-105339BP	Plan #1901 Two Story SFR - 1994 UBC	1997
New	1620 s.f. rambler with 2 car garage		1997
New	Approved Basic #97-105637BP	Plan #1234 SFR w/finished basement - 1994 UB	1997
New	40 x 66 - 1997 - Fleetwood		1997
New	2 story sfr - no garage		1997
New	Rambler with attached garage - 1994 UBC		1997
New	2 story w/3 car		1997
New	28 x 56 MH		1997
New	28 x 66 MH		1997
New	Rambler w/ 3 car		1997
New	24x50 1980 Liberty Oakbrook		1997
New	Approved Basic #95-108472BP	Plan 1446 Rambler Style SFR - 1994 UBC	1997
New	Approved Basic #95-108472BP	Plan 1446 Rambler Style SFR - 1994 UBC	1997
New	Approved Basic #95-109256BP	Plan #1520 Rambler Style SFR - 1994 UBC	1997
New	Approved Basic #96-102949BP	Two Story Duplex - 1994 UBC	1997
New	Two-story SFR w/attached garage	Plan 2294	1997
New	2 Story w/ 3 car		1997
New	Rambler Style SFR w/attached 3-car garage.		1997
New	Approved Basic #95-109785BP	Two Story SFR - 1994 UBC	1997
New	Approved Basic #95-109478BP	Two Story SFR - 1994 UBC	1997
New	Approved Basic #95-109272BP	Two Story SFR - 1994 UBC	1997
New	Approved Basic #96-101222BP	Two Story SFR- 1994 UBC	1997
New	Approved Basic #95-109478BP	Two Story SFR - 1994 UBC	1997
New	Approved Basic #95-109272BP	Two Story SFR - 1994 UBC	1997
New	Rambler style SFR w/attached Garage		1997
New	Approved Basic #97-108560	Two-story SFR w/attached garage	1997
New	Approved Basic #95-109272BP	Two Story SFR - 1994 UBC	1997
New	Approved Basic #97-108790BP	Plan #2084 Two Story SFR - 1994 UBC	1997
New	2207 sf 2-story w/470 + 264-sf garage and 95 sf covered deck/porch		1997
New	2364 sf 2-story w/784 sf garage and 23 sf covered deck/porch		1997
New	Two Story SFR - 1994 UBC		1997
New	One-story SFR w/attached garage		1997
New	Two story SFR w/ attached garage		1997
New	Approved Basic #95-109481BP	(3/4 car option approved) Two Story SFR - 1994 UBC	1997
New	Approved Basic #95-109478BP	Two Story SFR - 1994 UBC	1997
New	Two Story SFR - 1994 UBC		1997

Accessory Dwelling Units

Index # - File Name: 1.0022 - Single Family Dwellings Data\_Snohomish County.pdf

New	Approved Basic #95-108665BP	Two Story SFR - 1994 UBC	1997
New	Rambler Style SFR -1994 UBC	Plan #1828	1997
New	Approved Basic #95-109787BP	Two Story SFR - 1994 UBC	1997
New	2 story sfr w/ garage		1997
New	Approved Basic #95-109785BP	Two Story SFR - 1994 UBC	1997
New	Approved Basic #95-108665BP	Two Story SFR - 1994 UBC	1997
New	Approved Basic #97-108790BP	Plan #2084 Two Story SFR - 1994 UBC	1997
New	Approved Basic #97-108786	Plan #1918-3 Two Story SFR - 1994 UBC	1997
New	Split Level with attached garage - 1994 UBC		1997
New	2-Story SFR with attached garage - 1994 UBC		1997
New	One-story SFR w/attached garage		1997
New	2 Story SFR with attached garage - 1994 UBC		1997
New	42 x 52 1997 Triplewide Guerdon		1997
New	Approved Basic #97-108786	Plan #1918-3 Two Story SFR - 1994 UBC	1997
New	2 story SFR with attached garage		1997
New	Approved Basic #96-101222BP	Two Story SFR- 1994 UBC	1997
New	Two Story SFR - 1994 UBC	Plan #2020	1997
New	Approved Basic #96-106892BP	Two Story SFR - 1994 UBC	1997
New	2 Story w/3 car		1997
New	2 Story w/3 Car		1997
New	Approved Basic #97-108790BP	Plan #2084 Two Story SFR - 1994 UBC	1997
New	Two Story SFR with Attached Garage		1997
New	SFR with attached garage		1997
New	Two Story Duplex with Attached Garage		1997
New	2 story SFR w/ garage		1997
New	Rambler Style SFR with attached garage - 1994 UBC		1997
New	Two-story SFR w/attached garage		1997
New	Two-story SFR w/attached garage **Please end plan check process line for first plan check and		1997
New	3390sf 2-story w/937 sf garage and 81 sf covered deck/porch		1997
New	3538 sf 2-story w/110 sf garage and 48 sf covered porch		1997
New	2 Story w/3 car		1997
New	2-Story SFR w/attached Garage & Covered porches.		1997
New	2847sf 2 Story SFR with attached garage - 1994 UBC		1997
New	2-Story SFR w/attached Garage		1997
New	2361 s.f. rambler with 1013 2 car garage		1997
New	28 x 66 1996 Libery Doublewide		1997
New	1 story SFR w/ garage		1997
New	Two Story SFR with Finished Basement and Attached Garage		1997
New	1997 Silvercrest 27x56/60		1997
New	Approved Basic #96-101074BP	Two Story Duplex - 1994 UBC	1997
New	2 story sfr with 2 car garage		1997
New	2 story sfr with 3 car garage...STOP WORK (#2212) POSTED BY M.MC CRARY ON 11-25-97 AT 1:4		1997
New	Conversion of TD Mobile issued under acct # 4804-018-029-0009 (ZA9206071) to full time resid		1997
New	Approved Basic #96-101277BP	Plan 1732 Two Story SFR - 1994 UBC	1997
New	Approved Basic #96-100452BP	Plan 1930 Two Story SFR - 1994 UBC	1997
New	Approved Basic #96-105888BP	Two Story SFR - 1994 UBC	1997
New	Approved Basic #96-101277BP	Plan 1732 Two Story SFR - 1994 UBC	1997

Accessory Dwelling Units

Index # - File Name: 1.0022 - Single Family Dwellings Data\_Snohomish County.pdf

New	Approved Basic #96-109445BP	Plan #1715 Two Story SFR - 1994 UBC	1997
New	Approved Basic #96-101277BP	Plan 1732 Two Story SFR - 1994 UBC	1997
New	Approved Basic #96-101276BP	Plan 2005 Two Story SFR - 1994 UBC	1997
New	Approved Basic #96-100452BP	Plan 1930 Two Story SFR - 1994 UBC	1997
New	Approved Basic #96-100375BP	Plan #1502 Rambler Style SFR - 1994 UBC	1997
New	Approved Basic #96-109445BP	Plan #1715 Two Story SFR - 1994 UBC	1997
New	Approved Basic #96-101276BP	Plan 2005 Two Story SFR - 1994 UBC	1997
New	Approved Basic #96-100452BP	Plan 1930 Two Story SFR - 1994 UBC	1997
New	Approved Basic #96-109445BP	Plan #1715 Two Story SFR - 1994 UBC	1997
New	Approved Basic #96-101277BP	Plan 1732 Two Story SFR - 1994 UBC	1997
New	Approved Basic #96-100375BP	Plan #1502 Rambler Style SFR - 1994 UBC	1997
New	Approved Basic #96-100452BP	Plan 1930 Two Story SFR - 1994 UBC	1997
New	Approved Basic #96-109445BP	Plan #1715 Two Story SFR - 1994 UBC (Finaled	1997
New	Approved Basic #96-101276BP	Plan 2005 Two Story SFR - 1994 UBC	1997
New	Approved Basic #96-109445BP	Plan #1715 Two Story SFR - 1994 UBC	1997
New	Approved Basic #96-100452BP	Plan 1930 Two Story SFR - 1994 UBC	1997
New	Approved Basic #96-109445BP	Plan #1715 Two Story SFR - 1994 UBC	1997
New	Approved Basic #96-109445BP	Plan #1715 Two Story SFR - 1994 UBC	1997
New	Rambler Style SFR - 1994 UBC	Plan #1581	1997
New	Approved Basic #97-103626BP	Plan #1649 Two Story SFR - 1994 UBC	1997
New	Approved Basic #97-103669BP	Plan #1986 Two Story SFR - 1994 UBC	1997
New	Approved Basic #97-103623BP	Plan #1438 Rambler Style SFR - 1994 UBC	1997
New	Two Story SFR - 1994 UBC	Plan #2219	1997
New	Two Story SFR - 1994 UBC	Plan #2136	1997
New	Approved Basic #97-103623BP	Plan #1438 Rambler Style SFR - 1994 UBC	1997
New	2-Story SFR w/attached Garage		1997
New	Approved Basic #97-105540BP	Plan #1643 Tri-Level SFR w/finished lower f	1997
New	Approved Basic #97-105531BP	Plan #1729 Two Story SFR - 1994 UBC	1997
New	SFR w/finished basement - 1994 UBC	Plan #1927	1997
New	Approved Basic #97-107392BP	Plan #1812 Rambler Style SFR - 1994 UBC	1997
New	Approved Basic #97-105531BP	Plan #1729 Two Story SFR - 1994 UBC	1997
New	Approved Basic #97-107392BP	Plan #1812 Rambler Style SFR - 1994 UBC	1997
New	Approved Basic #97-105540BP	Plan #1643 Tri-Level SFR w/finished lower f	1997
New	Approved Basic #97-105531BP	Plan #1729 Two Story SFR - 1994 UBC	1997
New	Approved Basic #96-104979BP	Plan #1551 Rambler Style SFR - 1994 UBC	3rc 1997
New	Approved Basic #97-105540BP	Plan #1643 Tri-Level SFR w/finished lower f	1997
New	Approved Basic #97-105543BP	Plan #2200 Split Level SFR - 1994 UBC	1997
New	Approved Basic #96-104979BP	Plan #1551 Rambler Style SFR - 1994 UBC	1997
New	Approved Basic #96-104979BP	Plan #1551 Rambler Style SFR - 1994 UBC	1997
New	Approved Basic #97-101142BP	Plan 1665 Two Story SFR - 1994 UBC	1997
New	Approved Basic #96-104979BP	Rambler Style SFR - 1994 UBC	1997
New	Two Story SFR w/finished basement - 1994 UBC		1997
New	Approved Basic #97-101142BP	Plan 1665 Two Story SFR - 1994 UBC	1997
New	Two SFR w/finished basement - 1994 UBC		1997
New	Approved Basic #96-104979BP	Rambler Style SFR - 1994 UBC	1997
New	Approved Basic #97-101142BP	Plan 1665 Two Story SFR - 1994 UBC	1997
New	Approved Basic #97-101148BP	Plan #1365 Rambler Style SFR - 1994 UBC	1997

Accessory Dwelling Units

Index # - File Name: 1.0022 - Single Family Dwellings Data\_Snohomish County.pdf

New	Approved Basic #97-101148BP	Plan #1365	Rambler Style SFR - 1994 UBC	1997
New	Approved Basic #97-101148BP	Plan #1365	Rambler Style SFR - 1994 UBC	1997
New	Approved Basic #97-105531BP	Plan #1729	Two Story SFR - 1994 UBC	1997
New	Approved Basic #97-105540BP	Plan #1643	Tri-Level SFR w/finished lower f	1997
New	Approved Basic #97-101142BP	Plan 1665	Two Story SFR - 1994 UBC	1997
New	Approved Basic #97-101142BP	Plan 1665	Two Story SFR - 1994 UBC	1997
New	Approved Basic #97-105531BP	Plan #1729	Two Story SFR - 1994 UBC	1997
New	Approved Basic #96-104979BP	Plan #1551	Rambler Style SFR - 1994 UBC Optic	1997
New	Approved Basic #97-105531BP	Plan #1729	Two Story SFR - 1994 UBC	1997
New	Approved Basic #97-101148BP	Plan #1365	Rambler Style SFR - 1994 UBC	1997
New	Approved Basic #97-105540BP	Plan #1643	Tri-Level SFR w/finished lower f	1997
New	Approved Basic #96-104979BP	Plan #1551	Rambler Style SFR - 1994 UBC Optic	1997
New	Approved Basic #97-101148BP	Plan #1365	Rambler Style SFR - 1994 UBC	1997
New	Approved Basic #97-105540BP	Plan #1643	Tri-Level SFR w/finished lower f	1997
New	Approved Basic #97-103628BP	Plan #1581	Rambler Style SFR - 1994 UBC	1997
New	Approved Basic #97-103626BP	Plan #1649	Two Story SFR - 1994 UBC	1997
New	Two Story SFR - 1994 UBC	Plan #2136		1997
New	Approved Basic #97-103623BP	Plan #1438	Rambler Style SFR - 1994 UBC	1997
New	Approved Basic #97-103624BP	Plan #1701	Rambler Style SFR - 1994	1997
New	Approved Basic #97-103628BP	Plan #1581	Rambler Style SFR - 1994 UBC	1997
New	Rambler style SFR with attached garage			1997
New	Two Story SFR - 1994 UBC			1997
New	Rambler with attached Garage			1997
New	One-story SFR w/attached garage			1997
New	Split Level SFR with attached garage - 1994 UBC			1997
New	Two Story Duplex - 1994 UBC	Building 1		1997
New	Two Story Duplex - 1994 UBC	Building 3		1997
New	Two Story Duplex - 1994 UBC	Building 2		1997
New	Approved Basic #97-102871BP	Plan: Building 2	Two Story Duplex - 1994 UBC	1997
New	28 x 52 1991 Liberty Oakbrook			1997
New	Approved Basic #97-102874BP	Plan: Building 4	Two Story SFR - 1994 UBC	1997
New	Two Story SFR - 1994 UBC	Building 4		1997
New	Approved Basic #97-102874BP	Plan: Building 4	Two Story SFR - 1994 UBC	1997
New	Approved Basic #97-102874BP	Plan: Building 4	Two Story SFR - 1994 UBC	1997
New	Approved Basic #96-102793BP	OPTION: Approved	SFR w/finished basement - 1994 UB	1997
New	Approved Basic #96-102781BP	OPTION: Approved	Rambler Style SFR - 1994 UBC	1997
New	Approved Basic #96-102793BP	OPTION: Approved	SFR w/finished basement - 1994 UB	1997
New	1674 s.f. rambler with 2 car garage			1997
New	28x48; 1997 Silvercrest			1997
New	Approved Basic #96-102786BP	OPTION: Approved	Rambler Style SFR - 1994 UBC	1997
New	Approved Basic #96-102781BP	OPTION: Approved	Rambler Style SFR - 1994 UBC	1997
New	Approved Basic #96-102781BP	OPTION: Approved	Rambler Style SFR - 1994 UBC	1997
New	Approved Basic #96-102793BP	OPTION: Approved	SFR w/finished basement - 1994 UB	1997
New	Approved Basic #96-102793BP	OPTION: Approved	SFR w/finished basement - 1994 UB	1997
New	Approved Basic #96-102786BP	OPTION: Approved	Rambler Style SFR - 1994 UBC	1997
New	Approved Basic #96-102781BP	OPTION: Approved	Rambler Style SFR - 1994 UBC	1997
New	Approved Basic #96-102781BP	OPTION: Approved	Rambler Style SFR - 1994 UBC	1997



Accessory Dwelling Units

Index # - File Name: 1.0022 - Single Family Dwellings Data\_Snohomish County.pdf

New	Approved Basic #96-102793BP	OPTION: Approved	SFR w/finished basement - 1994 UBC	1997
New	Approved Basic #96-102793BP	OPTION: Approved	SFR w/finished basement - 1994 UBC	1997
New	Approved Basic #96-102786BP	OPTION: Approved	Rambler Style SFR - 1994 UBC	1997
New	Approved Basic #96-102793BP	OPTION: Approved	SFR w/finished basement - 1994 UBC	1997
New	Approved Basic #96-102793BP	OPTION: Approved	SFR w/finished basement - 1994 UBC	1997
New	Two Story 54 X 36 SFR			1997
New	One-story SFR w/attached garage			1997
New	One-story SFR w/finished basement - 1994 UBC			1997
New	2800 sf 2-story with 670 sf garage and 109 sf covered deck/porch			1997
New	Two-story SFR w/unfinished basement - 1994 UBC			1997
New	Two Story SFR with Attached Garage			1997
New	2-Story SFR w/attached garage-			1997
New	Two-story SFR - 1994 UBC			1997
New	Daylight Rambler Style with attached garage			1997
New	Two Story SFR with Attached Garage			1997
New	2368 sf rambler with 3 car garage			1997
New	2-Story SFR w/attached garage			1997
New	2 story sfr with 3 car garage			1997
New	Two Story SFR with attached Garage			1997
New	2-Story SFR w/attached garage			1997
New	48 x 28 (1997) Fleetwood			1997
New	One-story SFR			1997
New	28 x 44 1997 Palm Harbor			1997
New	Two Story SFR - 1994 UBC			1997
New	2 story sfr with 2 car garage			1997
New	27 X 44 Fleetwood 1997			1997
New	Two Story SFR with Finished Basement and Attached Garage			1997
New	Two story SFR w/attached garage			1997
New	Approved Basic #96-103802BP	Plan: #1884 - 2/3	Two Story SFR - 1994 UBC	1997
New	Approved Basic #96-100716BP	Option Approved - 3 car garage	Rambler Style SFR - 1	1997
New	Approved Basic #96-109567BP	Plan #2211	Two Story SFR - 1994 UBC	1997
New	Approved Basic #95-110755BP	(2/3 car option approved) Plan 1839	Two Story SFR - 1994 UBC	1997
New	Approved Basic #97-100801BP	Plan #2064	Two Story SFR - 1994 UBC	1997
New	Approved Basic #96-109567BP	Two Story SFR - 1994 UBC		1997
New	Approved Basic #97-100801BP	Plan #2064	Two Story SFR - 1994 UBC (Finaled by D.Daley)	1997
New	Approved Basic #95-110544BP	Plan: 2137 2/3	2 story SFR-2 or 3 car garage- 19	1997
New	Approved Basic #95-110544BP	Plan: 2137 2/3	2 story SFR-2 or 3 car garage- 19	1997
New	Approved Basic #96-109598BP	Plan - Brittany-3	Two Story SFR - 1994 UBC	1997
New	Approved Basic #97-100801BP	Plan #2064	Two Story SFR - 1994 UBC	1997
New	Two-story SFR w/attached garage			1997
New	Approved Basic #97-107554BP	2 Story w/2 car Garage (Finaled by D.Daley)		1997
New	Approved Basic #95-110544BP	Plan: 2137 2/3	2 story SFR-2 or 3 car garage- 19	1997
New	Two Story SFR - 1994 UBC			1997
New	Approved Basic #96-109598BP	Plan - Brittany-3	Two Story SFR - 1994 UBC (Finaled by D.Daley)	1997
New	Approved Basic #97-100801BP	Plan #2064	Two Story SFR - 1994 UBC (Finaled by D.Daley)	1997
New	Approved Basic #97-107299BP	Plan #2241/3	Two Story SFR - 1994 UBC	1997
New	2 story sfr with 3 car garage			1997

Accessory Dwelling Units

Index # - File Name: 1.0022 - Single Family Dwellings Data\_Snohomish County.pdf

New	Rambler with attached garage - 1994 UBC		1997
New	26 8 x60, 1997 Marlette Pacifica		1997
New	Approved Basic #96-109567BP	Plan #2211 Two Story SFR - 1994 UBC	1997
New	Approved Basic #95-110755BP (2/3 car option approved)	Plan 1839 Two Story SFR - 1994 UB	1997
New	Two-story SFR w/attached garage		1997
New	Approved Basic #97-107618BP	Plan #2211-B Two Story w/unfinished b:	1997
New	2-Story SFR w/attached Garage		1997
New	2 story sfr with 3 car garage		1997
New	Approved Basic #96-103802BP	Plan: #1884 - 2/3 Two Story SFR - 1994 UBC	1997
New	Two Story SFR - 1994 UBC	Plan #2368/3	1997
New	Approved Basic #96-109846BP	Plan 2330D/3 Two Story SFR - 1994 UBC	1997
New	3214 sf rambler w/784 sf garage		1997
New	2532 sf rambler w/763 sf garage and 232 sf covered deck/porch		1997
New	Approved Basic #95-110755BP (2/3 car option approved)	Plan 1839 Two Story SFR - 1994 UB	1997
New	1736 sf rambler w/473 sf garage and 50 sf covered deck/porch		1997
New	Approved Basic #96-103802BP	Plan: #1884 - 2/3 Two Story SFR - 1994 UBC	1997
New	Approval Basic #97-105892BP	Plan #2254 Two Story SFR - 1994 UBC	1997
New	Approval Basic #97-105892BP	Plan #2254 Two Story SFR - 1994 UBC	1997
New	Rambler with attached garage		1997
New	2-Story with attached garage - 1994 UBC		1997
New	Approved Basic #96-106675BP	Two Story SFR - 1994 UBC	1997
New	Approved Basic #96-109567BP	Plan #2211 Two Story SFR - 1994 UBC	1997
New	Approved Basic #97-105892BP	Plan #2254 Two Story SFR - 1994 UBC	1997
New	Approved Basic #96-109567BP	Plan #2211 Two Story SFR - 1994 UBC	1997
New	Approved Basic #96-109598BP	Plan - Brittany-3 Two Story SFR - 1994 UBC	1997
New	Approved Basic #96-107094BP	Two Story SFR - 1994 UBC	1997
New	Approved Basic #97-107299BP	Plan #2241/3 Two Story SFR - 1994 UBC	1997
New	Approved Basic #97-100801BP	Plan #2064 Two Story SFR - 1994 UBC	1997
New	Approved Basic #97-105350BP	Plan #2210 Two Story SFR - 1994 UBC (Nee	1997
New	Approved Basic #95-110544BP	Plan: 2137 2/3 2 story SFR-2 or 3 car garage- 19	1997
New	Approved Basic #96-106675BP	Two Story SFR - 1994 UBC	1997
New	2-story SFR with attached garage - 1994 UBC		1997
New	Approved Basic #96-101083BP	Two Story Duplex - 1994 UBC	1997
New	1997 27 x 52 Double wide Marlette		1997
New	2 story duplex w/garages		1997
New	1482 sf 2-story with 600 sf garage		1997
New	2-Story SFR with attached garage - 1994 UBC		1997
New	1904 sf Rambler with attached garage - 1994 UBC; ref fp2800495		1997
New	2 story SFR with attached garage		1997
New	Approved Basic #97-105464BP	Plan: Kira SFR w/unfinished lower floor ·	1997
New	Approved Basic #97-105464BP	Plan: Kira SFR w/unfinished lower floor ·	1997
New	Approved Basic #97-105464BP	Plan: Kira SFR w/unfinished lower floor ·	1997
New	Approved Basic #97-105464BP	Plan: Kira SFR w/unfinished lower floor ·	1997
New	Approved Basic #97-105464BP	Plan: Kira SFR w/unfinished lower floor ·	1997
New	Approved Basic #97-105464BP	Plan: Kira SFR w/unfinished lower floor ·	1997
New	Approved Basic #97-105464BP	Plan: Kira SFR w/unfinished lower floor ·	1997
New	Two-Story Daylight Basement	Plan: Kira	1997

Accessory Dwelling Units

Index # - File Name: 1.0022 - Single Family Dwellings Data\_Snohomish County.pdf

New	Approved Basic #97-105468BP	Plan: Barbara	SFR w/unfinished lower floor	1997
New	Approved Basic #97-105995BP	Plan: Cynthia	SFR w/unfinished basement - 1994	1997
New	Approved Basic #97-105991BP	Plan: Kimberly	Two Story SFR - 1994 UBC	1997
New	Approved Basic #97-105991BP	Plan: Kimberly	Two Story SFR - 1994 UBC	1997
New	Approved Basic #97-105995BP	Plan: Cynthia	SFR w/unfinished basement - 1994	1997
New	Approved Basic #97-105468BP	Plan: Barbara	SFR w/unfinished lower floor	1997
New	Approved Basic #97-105468BP	Plan: Barbara	SFR w/unfinished lower floor	1997
New	Approved Basic #97-105995BP	Plan: Cynthia	SFR w/unfinished basement - 1994	1997
New	Approved Basic #97-105995BP	Plan: Cynthia	SFR w/unfinished basement - 1994	1997
New	Approved Basic #97-105991BP	Plan: Kimberly	Two Story SFR - 1994 UBC	1997
New	Two Story SFR - 1994 UBC	Plan #Kimberly		1997
New	Tri-Level SFR w/attached garage.	Plan: Cynthia		1997
New	Two-Story Daylight Basement SFR - 1994 UBC	Plan: Barbara		1997
New	1242 sf living space with 494 sf finished basement and 437 sf garage			1997
New	1430 sf rambler w/693 sf garage and 96 sf covered porch			1997
New	28x66.7 (1986) Fleetwood			1997
New	2-Story SFR with unfin. Basement & Attached Garage.			1997
New	2 story sfr with 2 car garage			1997
New	SFR w/finished lower floor - 1994 UBC	Plan Plan 2195S-A/4T		1997
New	Approved Basic #97-105127BP	Plan #2025-T	Two Story SFR - 1994 UBC	1997
New	Two Story w/2 car - 1994 UBC	Plan 2265		1997
New	Approved Basic #97-105131BP	Plan #2265 C/2-3	Two Story SFR - 1994 UBC	1997
New	2 story sfr with 3 car garage			1997
New	Two-story SFR w/attached garage (Finaled by D.Daley on 12/10/97)			1997
New	2-Story SFR w/attached garage			1997
New	28 X 61 Redman 1981			1997
New	2 Story SFR with attached garage - 1994 UBC			1997
New	1997 Marlett 44 x 28			1997
New	1997 Marlett 28 x 46 8			1997
New	26 8 x52 - 1997 Fleetwood			1997
New	Rambler w/2 car - 1994 UBC			1997
New	Two Story SFR - 1994 UBC			1997
New	Two Story SFR - 1994 UBC			1997
New	Two Story SFR with attached Garage and Finished Basement			1997
New	26 8 x 66 8 1998 Marlette			1997
New	Split Entry SFR w/basement garage			1997
New	Approved Basic #106638BP	Plan #1927	Two Story SFR - 1994 UBC	1997
New	Approved Basic #96-109996BP	Plan 3	Two Story SFR - 1994 UBC	1997
New	Approved Basic #97-110397BP	Plan 5A	Two Story SFR - 1994 UBC	1997
New	Approved Basic #96-109827BP	Plan 4	Two Story SFR - 1994 UBC	1997
New	Approved Basic #97-110397BP	Plan 5A	Two Story SFR - 1994 UBC	1997
New	Approved Basic #97-110397BP	Plan 5A	Two Story SFR - 1994 UBC	1997
New	Approved Basic #97-110400BP	Plan 1	Two Story SFR - 1994 UBC	1997
New	Approved Basic #97-110397BP	Plan 5A	Two Story SFR - 1994 UBC	1997
New	Approved Basic #97-110397BP	Plan 5	Two Story SFR - 1994 UBC	1997
New	Approved Basic #97-110397BP	Plan 5A	Two Story SFR - 1994 UBC	1997
New	Approved Basic #97-110400BP	Plan 1	Two Story SFR - 1994 UBC ***STOP W	1997

Accessory Dwelling Units

Index # - File Name: 1.0022 - Single Family Dwellings Data\_Snohomish County.pdf

New	Two Story SFR - 1994 UBC	Plan #4c	1997
New	Approved Basic #96-109996BP	Plan 3 Two Story SFR - 1994 UBC	1997
New	Approved Basic #97-110400 BP	Plan 1 Two Story SFR - 1994 UBC	1997
New	Approved Basic #97-110400BP	Plan 1 Two Story SFR - 1994 UBC	1997
New	Approved Basic #97-110400BP	Plan 1 Two Story SFR - 1994 UBC	1997
New	Approved Basic #96-109827BP	Plan 4, 4a, 4b, 4c Two Story SFR - 1994 UBC	1997
New	Approved Basic #97-110400BP	Plan 1 Two Story SFR - 1994 UBC	1997
New	Approved Basic #97-104031BP	Plan #1504 SFR w/finished lower floor - :	1997
New	Approved Basic #97-104028BP	Plan #123093 Two Story SFR - 1994 UBC	1997
New	Approved Basic #97-104028BP	Plan #123093 Two Story SFR - 1994 UBC	1997
New	Approved Basic #97-104031BP	Plan #1504 SFR w/finished lower floor - :	1997
New	Approved Basic #97-104031BP	Plan #1504 SFR w/finished lower floor - :	1997
New	Approved Basic #97-104028BP	Plan #123093 Two Story SFR - 1994 UBC	1997
New	Approved Basic #97-104028BP	Plan #123093 Two Story SFR - 1994 UBC	1997
New	Approved Basic #97-104031BP	Plan #1504 SFR w/finished lower floor - :	1997
New	Approved Basic #97-104030BP	Plan #1450 Rambler Style SFR - 1994 UBC	1997
New	Approved Basic #97-104030BP	Plan #1450 Rambler Style SFR - 1994 UBC	1997
New	Approved Basic #97-104031BP	Plan #1504 SFR w/finished lower floor - :	1997
New	Approved Basic #97-104030BP	Plan #1450 Rambler Style SFR - 1994 UBC	1997
New	Approved Basic #97-104031BP	Plan #1504 SFR w/finished lower floor - :	1997
New	Approved Basic #97-104028BP	Plan #123093 Two Story SFR - 1994 UBC	1997
New	Approved Basic #97-104030BP	Plan #1450 Rambler Style SFR - 1994 UBC	1997
New	Approved Basic #97-104031BP	Plan #1504 SFR w/finished lower floor - :	1997
New	Approved Basic #97-104030BP	Plan #1450 Rambler Style SFR - 1994 UBC	1997
New	Approved Basic #97-104030BP	Plan #1450 Rambler Style SFR - 1994 UBC	1997
New	40 X 60 1994 Barrington by Fleetwood		1997
New	2- Story with daylighted and attached garage - 1994 UBC		1997
New	Approved Basic #97-107334BP	Split Level SFR w/unfinished lower floor - 1994 UBC	1997
New	2 story sfr with 3 car garage		1997
New	2080 sf Rambler with attached garage - 1994 UBC	RSP approved 12/31/97 ***WHEN FINALED	1997
New	Approved Basic #97-111003BP	Plan #2018 Two Story SFR - 1994 UBC	1997
New	Approved Basic #97-104831BP	Plan 1639 Two Story SFR - 1994 UBC	1997
New	Approved Basic #97-104829BP	Plan #1661 Two Story SFR - 1994 UBC	1997
New	Approved Basic #97-104831BP	Plan 1639 Two Story SFR - 1994 UBC	1997
New	Approved Basic #97-104822BP	Plan #1775 Two Story SFR - 1994 UBC	1997
New	Approved Basic #97-104831BP	Plan 1639 Two Story SFR - 1994 UBC	1997
New	Approved Basic #97-101584BP	Plan #1895 Two Story SFR - 1994 UBC	1997
New	Approved Basic #97-104556BP	Plan #1389 Two Story SFR - 1994 UBC	1997
New	Approved Basic #97-104831BP	Plan 1639 Two Story SFR - 1994 UBC	1997
New	Approved Basic #97-104822BP	Plan #1775 Two Story SFR - 1994 UBC	1997
New	Approved Basic #97-101584BP	Plan #1895 Two Story SFR - 1994 UBC	1997
New	Approved Basic #97-104556BP	Plan #1389 Two Story SFR - 1994 UBC	1997
New	Approved Basic #97-104831BP	Plan 1639 Two Story SFR - 1994 UBC	1997
New	Two Story SFR - 1994 UBC		1997
New	Approved Basic #97-104831BP	Plan 1639 Two Story SFR - 1994 UBC	1997
New	Approved Basic #97-104556BP	Plan #1389 Two Story SFR - 1994 UBC	1997
New	Approved Basic #97-104831BP	Plan 1639 Two Story SFR - 1994 UBC	1997

Accessory Dwelling Units

Index # - File Name: 1.0022 - Single Family Dwellings Data\_Snohomish County.pdf

New	Approved Basic #97-104831BP	Plan 1639	Two Story SFR - 1994 UBC	1997
New	Approved Basic #97-104556BP	Plan #1389	Two Story SFR - 1994 UBC	1997
New	Approved Basic #97-104822BP	Plan #1775	Two Story SFR - 1994 UBC	1997
New	Approved Basic #97-104831BP	Plan 1639	Two Story SFR - 1994 UBC	1997
New	Approved Basic #97-104822BP	Plan #1775	Two Story SFR - 1994 UBC	1997
New	Approved Basic #97-104831BP	Plan 1639	Two Story SFR - 1994 UBC	1997
New	Approved Basic #97-104829BP	Plan #1661	Two Story SFR - 1994 UBC	1997
New	Approved Basic #97-104831BP	Plan 1639	Two Story SFR - 1994 UBC	1997
New	SFR w/ basement & Garage			1997
New	Approved Basic #97-108489	Rambler w/attached garage		1997
New	Approved Basic #96-102270BP	Plan #2054	Two Story SFR - 1994 UBC	1997
New	Approved Basic #95-109726BP	Two Story SFR - 1994 UBC	Option Approved - Elv. C & 3i	1997
New	Approved Basic #95- 108133BP	Plan #1655	Tri-Level SFR - 1994 UBC	1997
New	Approved Basic #95-109726BP	Two Story SFR - 1994 UBC	Option Approved - Elv. C & 3i	1997
New	Approved Basic #96-102270BP	Plan #2054	Two Story SFR - 1994 UBC	1997
New	Approved Basic #95-109726BP	Two Story SFR - 1994 UBC	Option Approved - Elv. C & 3i	1997
New	Approved Basic #96-100746BP	Plan #1552	Rambler Style SFR - 1994 UBC	1997
New	Approved Basic #95-109726BP	Two Story SFR - 1994 UBC	Option Approved - Elv. C & 3i	1997
New	Approved Basic #96-102270BP	Plan #2054	Two Story SFR - 1994 UBC	1997
New	Approved Basic #95-109726BP	Two Story SFR - 1994 UBC	Option Approved - Elv. C & 3i	1997
New	Approved Basic #96-100746BP	Plan #1552	Rambler Style SFR - 1994 UBC	1997
New	Approved Basic #96-102270BP	Plan #2054	Two Story SFR - 1994 UBC	1997
New	Approved Basic #95-108812BP	Plan #1384	Two Story SFR - 1994 UBC	1997
New	Approved Basic #95-109726BP	Two Story SFR - 1994 UBC	Option Approved - Elv. C & 3i	1997
New	Approved Basic #96-100746BP	Plan #1552	Rambler Style SFR - 1994 UBC	1997
New	Approved Basic #96-102270BP	Plan #2054	Two Story SFR - 1994 UBC	1997
New	Approved Basic #95-109726BP	Two Story SFR - 1994 UBC	Option Approved - Elv. C & 3i	1997
New	Approved Basic #96-100746BP	Plan #1552	Rambler Style SFR - 1994 UBC	1997
New	Approved Basic #95- 108133BP	Plan #1655	Tri-Level SFR - 1994 UBC	1997
New	Approved Basic #95-109726BP	Two Story SFR - 1994 UBC	Option Approved - Elv. C & 3i	1997
New	Approved Basic #96-100746BP	Plan #1552	Rambler Style SFR - 1994 UBC	1997
New	Approved Basic #96-102270BP	Plan #2054	Two Story SFR - 1994 UBC	1997
New	Approved Basic #95-109726BP	Two Story SFR - 1994 UBC	Option Approved - Elv. C & 3i	1997
New	Approved Basic #96-100746BP	Plan #1552	Rambler Style SFR - 1994 UBC	1997
New	Approved Basic #97-109587-BP	1675 sf Rambler w/attached garage		1997
New	Approved Basic #96-101074BP	Two Story Duplex - 1994 UBC		1997
New	Approved Basic #96-103350BP	Two Story SFR -1994 UBC		1997
New	Two-story SFR w/attached garage			1997
New	Rambler Style SFR with attached garage			1997
New	2 Story SFR with attached garage			1997
New	27 x 60 Silvercrest			1997
New	Two-story duplex w/attached garages			1997
New	Two-story SFR w/attached garage			1997
New	Approved Basic #95-110755BP	(2/3 car option approved) Plan 1839	Two Story SFR - 1994 UB	1997
New	Approved Basic #96-109288BP	Two Story SFR - 1994 UBC	Plan 1887 -2/3	1997
New	Approved Basic #97-105096BP	Plan #2065	Two Story SFR - 1994 UBC	1997
New	2-Story SFR with attached garage - 1994 UBC			1997

Accessory Dwelling Units

Index # - File Name: 1.0022 - Single Family Dwellings Data\_Snohomish County.pdf

New	Approved Basic #97-111529BP	Plan #2120	Two Story SFR - 1994 UBC	1997
New	Approved Basic #97-111529BP	Plan #2120	Two Story SFR - 1994 UBC	1997
New	Approved Basic #96-109567BP	Plan #2211	Two Story SFR - 1994 UBC	1997
New	Approval Basic #97-105892BP	Plan #2254	Two Story SFR - 1994 UBC	1997
New	Approved Basic #97-111629BP	2415 sf 2-story w/630 sf garage and 240 sf covered deck/porch		1997
New	Approved Basic #95-110755BP	(2/3 car option approved) Plan 1839	Two Story SFR - 1994 UB	1997
New	Approved Basic #95-110544BP	Plan: 2137 2/3	2 story SFR-2 or 3 car garage- 19	1997
New	Approved Basic #96-100763BP	Two Story SFR - 1994 UBC	(2/3 car option)	1997
New	Approved Basic #95-110544BP	Plan: 2137 2/3	2 story SFR-2 or 3 car garage- 19	1997
New	Approved Basic #95-110544BP	Plan: 2137 2/3	2 story SFR-2 or 3 car garage- 19	1997
New	Approved Basic #97-111182BP	Plan #2070	Two Story SFR - 1994 UBC	1997
New	Approved Basic #97-110034BP	Plan #2154	Two Story SFR - 1994 UBC	1997
New	Two Story SFR - 1994 UBC	Plan #2120		1997
New	Approved Basic #95-110755BP	(2/3 car option approved) Plan 1839	Two Story SFR - 1994 UB	1997
New	Approved Basic #95-110755BP	(2/3 car option approved) Plan 1839	Two Story SFR - 1994 UB	1997
New	Approved Basic #95-109379BP	Plan 1936	Two Story SFR - 1994 UBC	1997
New	Approved Basic #97-110034BP	Plan #2154	Two Story SFR - 1994 UBC	1997
New	Approved Basic #95-110544BP	Plan: 2137 2/3	2 story SFR-2 or 3 car garage- 19	1997
New	Approved Basic #97-110037BP	Plan #2198	Two Story SFR - 1994 UBC	1997
New	Approved Basic #96-109132BP	Plan #2154	Two Story SFR - 1994 UBC	1997
New	Approved Basic #96-109132BP	Plan #2154	Two Story SFR - 1994 UBC	1997
New	Approved Basic #96-109905BP	Plan 1917	Two Story SFR - 1994 UBC	1997
New	Approved Basic #97-110188BP	SFR w/finished basement - 1994 UBC		1997
New	2026 s.f. sfr with 1241 finished basement and 2 car garage.			1997
New	1997 66 x 27 Golden West			1997
New	Two story SFR w/attached garage			1997
New	2 story with attached garage			1997
New	Approved Basic #97-110341BP	Two Story SFR - 1994 UBC		1997
New	Rambler w/ 2 car			1997
New	Approved Basic #96-103350BP	Two Story SFR -1994 UBC		1997
New	Approved Basic #96-108624BP	Plan #1365	SFR w/finished basement - 1994 UBC	1997
New	2225 sf 2-story with 910 sf garage and 56 sf covered deck/porch			1997
New	1750sf 2-story with 400 sf garage and 84 sf covered deck/porch			1997
New	Two-story SFR w/attached garage	Eng - James Clark Johnson #15691		1997
New	Split Level style SFR with attached garage	- 1994 UBC		1997
New	Split Level style SFR with attached garage			1997
New	27 x 56 1997 Fleetwood			1997
New	2 story SFR			1997
New	28 x 48 Doublewide 1997 Oakwood			1997
New	Approved Basic 95-107925BP	(Builders Plan #1740) 0 lot line stucture	Two Story SFR - 19	1997
New	Approved Basic #95-108149BP	(0 lot line structure) Plan #2043	Two Story SFR - 1994 UBC	1997
New	Approved Basic #96-100749BP	Plan #1618	SFR w/finished basement - 1994 UBC	1997
New	Approved Basic 95-107925BP	(Builders Plan #1740) 0 lot line stucture	Two Story SFR - 19	1997
New	Approved Basic #95-108149BP	(0 lot line structure) Plan #2043	Two Story SFR - 1994 UBC	1997
New	Approved Basic #95-108526BP	SFR w/unfinished basement	1994 UBC	1997
New	Approved Basic #95-108527BP	SFR w/unfinished basement	1994 UBC	1997
New	Approved Basic #95-108526BP	SFR w/unfinished basement	1994 UBC	1997

Accessory Dwelling Units

Index # - File Name: 1.0022 - Single Family Dwellings Data\_Snohomish County.pdf

New	Approved Basic #95-108527BP	SFR w/unfinished basement	1994 UBC	1997
New	Approved Basic 97-101497BP	Plan #071487	Two Story SFR - 1994 UBC	1997
New	52x27 (1997) Fleetwood			1997
New	Approved Basic #95-108526BP	SFR w/unfinished basement	1994 UBC	1997
New	2 Story with attached garage - 1994 UBC			1997
New	24x44, 1995 Gibraltar			1997
New	Approved Basic #97-107464BP	Plan #1610	SFR w/finished basement - 1994	1997
New	Approved Basic #95-109432BP	Two Story SFR with 2/3 car - 1994 UBC		1997
New	Approved Basic #97-109602BP	Plan #1827	SFR w/finished basement - 1994	1997
New	Approved Basic #95-109432BP	Two Story SFR with 2/3 car - 1994 UBC		1997
New	Approved Basic #97-109602BP	Plan #1827	SFR w/finished basement - 1994	1997
New	2562 sf 2-story w/832 sf garage and 80sf covered porch (Finaled by C.Koch on 12/4/97)			1997
New	1217 sf rambler with 480 sf unfinished basement and 576 sf garage			1997
New	Approved Basic #96-101074BP	Two Story Duplex - 1994 UBC		1997
New	Two Story Duplex - 1994 UBC	Plan 1194		1997
New	Approved Basic #96-101074BP	Two Story Duplex - 1994 UBC		1997
New	Two Story SFR - 1994 UBC			1997
New	Two-story w/attached garage			1997
New	Rambler style duplex with attached garages			1997
New	2-Story SFR with unfin. basement			1997
New	Approved Basic #95-108526BP	SFR w/unfinished basement	1994 UBC	1997
New	Approved Basic #95-108527BP	SFR w/unfinished basement	1994 UBC	1997
New	Approved Basic #95-108526BP	SFR w/unfinished basement	1994 UBC	1997
New	Approved Basic #96-109755BP	Plan 1278	Two Story SFR - 1994 UBC	1997
New	Approved Basic #95-108527BP	SFR w/unfinished basement	1994 UBC	1997
New	Approved Basic #95-108526BP	SFR w/unfinished basement	1994 UBC	1997
New	Approved Basic #95-108149BP	(0 lot line structure) Plan #2043	Two Story SFR - 1994 UBC	1997
New	Approved Basic #95-108149BP	(0 lot line structure) Plan #2043	Two Story SFR - 1994 UBC	1997
New	Approved Basic #95-108149BP	(0 lot line structure) Plan #2043	Two Story SFR - 1994 UBC	1997
New	Approved Basic #96-100749BP	Plan #1618	SFR w/finished basement - 1994 UBC	1997
New	Approved Basic #96-100749BP	Plan #1618	SFR w/finished basement - 1994 UBC	1997
New	Approved Basic 95-107925BP	(Builders Plan #1740) 0 lot line structure	Two Story SFR - 1994 UBC	1997
New	Approved Basic 95-107925BP	(Builders Plan #1740) 0 lot line structure	Two Story SFR - 1994 UBC	1997
New	Approved Basic 95-107925BP	(Builders Plan #1740) 0 lot line structure	Two Story SFR - 1994 UBC	1997
New	Approved Basic #95-108527BP	SFR w/unfinished basement	1994 UBC	1997
New	Approved Basic #95-108526BP	SFR w/unfinished basement	1994 UBC	1997
New	Approved Basic #95-108526BP	SFR w/unfinished basement	1994 UBC	1997
New	Approved Basic #95-108527BP	SFR w/unfinished basement	1994 UBC	1997
New	Approved Basic #95-108526BP	SFR w/unfinished basement	1994 UBC	1997
New	Approved Basic #95-108527BP	SFR w/unfinished basement	1994 UBC	1997
New	Approved Basic #95-108526BP	SFR w/unfinished basement	1994 UBC	1997
New	Approved Basic #95-108527BP	SFR w/unfinished basement	1994 UBC	1997
New	Approved Basic #95-108526BP	SFR w/unfinished basement	1994 UBC	1997
New	Approved Basic #95-108527BP	SFR w/unfinished basement	1994 UBC	1997
New	Approved Basic #95-108526BP	SFR w/unfinished basement	1994 UBC	1997
New	Approved Basic #95-108527BP	SFR w/unfinished basement	1994 UBC	1997
New	Approved Basic #95-108526BP	SFR w/unfinished basement	1994 UBC	1997
New	Approved Basic #95-108527BP	SFR w/unfinished basement	1994 UBC	1997
New	Approved Basic #95-108526BP	SFR w/unfinished basement	1994 UBC	1997
New	Approved Basic #95-108527BP	SFR w/unfinished basement	1994 UBC	1997
New	Approved Basic #95-108526BP	SFR w/unfinished basement	1994 UBC	1997

Accessory Dwelling Units

Index # - File Name: 1.0022 - Single Family Dwellings Data\_Snohomish County.pdf

New	2-Story SFR			1997
New	Approved Basic #97-105813BP	Plan #1412	Rambler Style SFR - 1994 UBC	1997
New	Approved Basic #97-105813BP	Plan #1412	Rambler Style SFR - 1994 UBC	1997
New	Approved Basic #95-109432BP	Two Story SFR with 2/3 car - 1994 UBC		1997
New	Approved Basic #97-109602BP	Plan #1827	SFR w/finished basement - 1994	1997
New	Approved Basic #95-109432BP	Two Story SFR with 2/3 car - 1994 UBC		1997
New	Pending Basic #97-107464BP	Plan #1610	SFR w/finished basement - 1994 U	1997
New	Rambler Style SFR - 1994 UBC	Plan #1827	CS/2	1997
New	2 story with attached garge			1997
New	Approved Basic #96-101074BP	Two Story Duplex - 1994 UBC (Finaled by D.Ericksen)		1997
New	2 story sfr with 3 car garage			1997
New	Approved Basic #96-102781BP	OPTION: Approved	Rambler Style SFR - 1994 UBC	1997
New	Approved Basic #96-102786BP	OPTION: Approved	Rambler Style SFR - 1994 UBC	1997
New	Approved Basic #96-107790BP	Two Story SFR - 1994 UBC		1997
New	2 story SFR with attached garage			1997
New	Rambler Style SFR - 1994 UBC			1997
New	Approved Basic #96-102781BP	OPTION: Approved	Rambler Style SFR - 1994 UBC	1997
New	Approved Basic #96-102786BP	OPTION: Approved	Rambler Style SFR - 1994 UBC	1997
New	Approved Basic #96-102793BP	OPTION: Approved	SFR w/finished basement - 1994 UB	1997
New	Approved Basic #97-106974BP	Plan 2640	Two Story SFR - 1994 UBC	1997
New	Approved Basic #96-102793BP	OPTION: Approved	SFR w/finished basement - 1994 UB	1997
New	Approved Basic #96-102781BP	OPTION: Approved	Rambler Style SFR - 1994 UBC	1997
New	Approved Basic #96-102781BP	OPTION: Approved	Rambler Style SFR - 1994 UBC	1997
New	Approved Basic #96-102781BP	OPTION: Approved	Rambler Style SFR - 1994 UBC	1997
New	Approved Basic #96-102793BP	OPTION: Approved	SFR w/finished basement - 1994 UB	1997
New	Approved Basic #96-102793BP	OPTION: Approved	SFR w/finished basement - 1994 UB	1997
New	Approved Basic #96-102793BP	OPTION: Approved	SFR w/finished basement - 1994 UB	1997
New	Approved Basic #96-102781BP	OPTION: Approved	SFR w/finished basement - 1994 UB	1997
New	Approved Basic #96-102786BP	OPTION: Approved	Rambler Style SFR - 1994 UBC (Fina	1997
New	Approved Basic #96-102793BP	OPTION: Approved	SFR w/finished basement - 1994 UB	1997
New	Rambler Style SFR with attached garage			1997
New	Rambler style SFR with attached garage			1997
New	2 story SFR with attached garage			1997
New	Split level SFR with attached garage			1997
New	Approved Basic #96-101277BP	Plan 1732	Two Story SFR - 1994 UBC	1997
New	Approved Basic #96-109445BP	Plan #1715	Two Story SFR - 1994 UBC	1997
New	28x60 Dbl Wide Mobile Home			1997
New	Split w 2 car			1997
New	28 X 42 Marlette 1997			1997
New	14x70 1974 Glenbrook			1997
New	28x66 (1997) Fleetwood			1997
New	28x66 (1997) Fleetwood #4663B			1997
New	Approved Basic #97-104356BP		Rambler Style SFR - 1994 UBC	1997
New	Rambler with day-lighted and attached garage - 1994 UBC			1997
New	28x60, 1980 Fleetwood			1997
New	14 x 66 1993 Marlette Series 20			1997
New	SPACE 94			1997
New	Two Story SFR - 1994 UBC	Plan #1665/2		1997



Accessory Dwelling Units

Index # - File Name: 1.0022 - Single Family Dwellings Data\_Snohomish County.pdf

New	Two Story SFR - 1994 UBC	Plan: 1665/2	1997
New	Rambler Style SFR - 1994 UBC	Plan 1420 R/2-3	1997
New	Rambler w/ 2 car		1997
New	2 Story w/Bsmt & 3 Car		1997
New	1319 sf rambler w/484 sf garage and 240 sf open deck		1997
New	855 sf rambler w/428 sf finished basement and 529 sf garage		1997
New	Approved Basic #97-110967BP	Plan #1415 SFR w/finished lower floor - 1994 U	1997
New	Approved Basic #97-110966BP	Plan #100596 SFR w/finished lower floor - 199	1997
New	Two Story SFR		1997
New	2 story sfr with 3 car garage		1997
New	2 story sfr with 3 car garage		1997
New	Approved Basic #97-106334BP	Plan 1938 Two Story SFR - 1994 UBC	1997
New	Approved Basic #96-102452BP	Two Story SFR w/2 or 3 car garage - 1994 UBC	1997
New	Two Story SFR - 1994 UBC	Plan #1990A	1997
New	Two Story SFR - 1994 UBC	Plan: 1732T	1997
New	Two Story SFR - 1994 UBC		1997
New	Two Story SFR - 1994 UBC	Plan #7000/plan 3	1997
New	Two Story SFR - 1994 UBC	Plan #7000/plan 2	1997
New	Two Story SFR - 1994 UBC	Plan #7000/plan 1	1997
New	Two Story SFR - 1994 UBC	Plan #4500/plan 3	1997
New	Two Story SFR - 1994 UBC	Plan #4500/plan 2	1997
New	Two Story SFR - 1994 UBC	Plan #4500/plan 1	1997
New	Two Story SFR - 1994 UBC	Plan #5500/plan 1	1997
New	Two Story SFR - 1994 UBC	Plan #5500 plan 2	1997
New	Two Story SFR - 1994 UBC	Plan #5500/plan 3	1997
New	Two Story SFR - 1994 UBC	Plan #5214/5314	1997
New	Two Story SFR - 1994 UBC	Plan #5019/5119	1997
New	2-Story SFR (Finaled by B.Humphreys on 12/8/97)		1997
New	Two Story SFR - 1994 UBC		1997
New	Rambler style SFR		1997
New	Two-story SFR w/attached garage		1998
New	3256 sf 2-story w/804 sf garage and 64 sf covered deck/porch		1998
New	2-Story SFR w/attached garage & Unfin. partial Basement.		1998
New	2 story SFR with attached garage		1998
New	Two Story SFR - 1997 UBC	Plan #Luarel	1998
New	2 Story SFR w/ attached garage	Plan-Holly	1998
New	2 story SFR w/ attached garage	Paln #Holly	1998
New	2 Story SFR w attached Garage	PLan-Holly	1998
New	2 story SFR w/ attached garage	Plan#Laurel	1998
New	Two Story SFR - 1997 UBC	Plan #Holly	1998
New	1998 67 x 27 Silvercrest		1998
New	1972 24x60 Goldenwest		1998
New	2 story SFR with attached garage		1998
New	2 Story w/2 Car		1998
New	Approved Basic #98-110213BP	Plan #1333 Two Story Duplex - 19	1998
New	Approved Basic #98-110213BP	Plan #1333 Two Story Duplex - 19	1998
New	2 story w/2 car		1998

Accessory Dwelling Units

Index # - File Name: 1.0022 - Single Family Dwellings Data\_Snohomish County.pdf

New	2-Story SFR w/attached garage		1998
New	2-Story SFR w/attached garage.		1998
New	2 story SFR with attached garage		1998
New	2 Story with attached garage and covered porch - 1997 UBC		1998
New	Approved Basic #98-116666BP	Plan: 1786 Two-story SFR w/attached	1998
New	Approved Basic #98-116666BP	Plan: 1786 Two-story SFR w/attached	1998
New	Approved Basic #98-116672BP	Plan: P-100297 One-story SFR w/finisl	1998
New	Approved Basic #98-116672BP	Plan: P-100297 One-story SFR w/finisl	1998
New	Approved Basic #98-116666BP	Plan: 1786 Two-story SFR w/attached	1998
New	Approved Basic #98-116672BP	Plan: P-100297 One-story SFR w/finisl	1998
New	Approved Basic #98-116666BP	Plan: 1786 Two-story SFR w/attached	1998
New	Two Story SFR - 1997 UBC	Plan: #2400 A/3	1998
New	Two Story SFR - 1997 UBC	Plan: #2330 B-3	1998
New	Two Story SFR - 1997 UBC	Plan: #2130 G-3	1998
New	Two Story SFR - 1997 UBC	Plan: #2339	1998
New	27 x 56 - 1998 - Palm Harbor		1998
New	28x70 (1988) Champion		1998
New	Two-story SFR w/attached garage		1998
New	2 car sfr w/2 car garage- 1997 UBC		1998
New	Two Story SFR with Attached Garage - 1997 UBC		1998
New	Approved Basic #98-116802BP	Two Story Duplex - 1997 UBC	1998
New	Approved Basic #98-116802BP	Two Story Duplex - 1997 UBC	1998
New	Approved Basic #98-116802BP	Two Story Duplex - 1997 UBC	1998
New	2 story sfr with 2 car garage		1998
New	Split w/2 Car Plan #1283		1998
New	Approved Basic #98-108803BP	Plan 1750 Cal 1174 sf SFR w/56	1998
New	Approved Basic #98-108806BP	Plan 1936 Split 1174 sf SFR w/762 sf ur	1998
New	Approved Basic #98-108803BP	Plan 1750 Cal 1174 sf SFR w/56	1998
New	Approved Basic #98-108806BP	Plan 1936 Split 1174 sf SFR w/762 sf ur	1998
New	Approved Basic #98-108803BP	Plan 1750 Cal 1174 sf SFR w/56	1998
New	Approved Basic #98-108806BP	Plan 1936 Split 1174 sf SFR w/762 sf ur	1998
New	Approved Basic #98-108803BP	Plan 1750 Cal 1174 sf SFR w/56	1998
New	Approved Basic #98-108806BP	Plan 1936 Split 1174 sf SFR w/762 sf ur	1998
New	Approved Basic #98-108977BP	Plan #1344 R Two Story SFR - 1997 UB	1998
New	3571-sf Rambler style SFR w/attached garage		1998
New	Two Story Duplex - 1997 UBC		1998
New	Approved Basic #98-110516BP Two Story SFR - 1997 UBC	Plan: 24	1998
New	Approved Basic #98-116802BP	Two Story Duplex - 1997 UBC	1998
New	Approved Basic #98-110516BP Two Story SFR - 1997 UBC	Plan: 24	1998
New	Rambler w/bonus on upper floor - 1997 UBC	Plan: Rambler w/bonus	1998
New	Rambler style SFR with attached garage		1998
New	Rambler style SFR with attached garage		1998
New	Rambler w/3 Car Builders Plan #2500		1998
New	Rambler w/3 Car Builders Plan #2300		1998
New	1 story Rambler w/ attached 3 car garage		1998
New	Approved Basic #98-110516BP Two Story SFR - 1997 UBC	Plan: 24	1998
New	Two Story SFR - 1997 UBC	Plan: #451	1998

Accessory Dwelling Units

Index # - File Name: 1.0022 - Single Family Dwellings Data\_Snohomish County.pdf

New	Approved Basic #98-110000BP	Two Story SFR - 1997 UBC	Plan: #450	1998
New	Approved Basic #98-110000BP	Two Story SFR - 1997 UBC	Plan: #450	1998
New	Approved Basic #98-109999BP	Two Story SFR - 1997 UBC	Plan: #450	1998
New	Approved Basic #98-109999BP	Two Story SFR - 1997 UBC	Plan: #450	1998
New	Approved Basic #98-109999BP	Two Story SFR - 1997 UBC	Plan: #450	1998
New	Approved Basic #98-109999BP	Two Story SFR - 1997 UBC	Plan: #450	1998
New	Approved Basic #98-109999BP	Two Story SFR - 1997 UBC	Plan: #450	1998
New	Approved Basic #98-110000BP	Two Story SFR - 1997 UBC	Plan: #450	1998
New	Approved Basic #98-109999BP	Two Story SFR - 1997 UBC	Plan: #450	1998
New	Approved Basic #98-109999BP	Two Story SFR - 1997 UBC	Plan: #450	1998
New	Approved Basic #98-109999BP	Two Story SFR - 1997 UBC	Plan: #450	1998
New	Approved Basic #98-109999BP	Two Story SFR - 1997 UBC	Plan: #450	1998
New	Approved Basic #98-109999BP	Two Story SFR - 1997 UBC	Plan: #450	1998
New	Approved Basic #98-109999BP	Two Story SFR - 1997 UBC	Plan: #450	1998
New	Approved Basic #98-109999BP	Two Story SFR - 1997 UBC	Plan: #450	1998
New	Approved Basic #98-109999BP	Two Story SFR - 1997 UBC	Plan: #450	1998
New	Approved Basic #98-109999BP	Two Story SFR - 1997 UBC	Plan: #450	1998
New	Approved Basic #98-109999BP	Two Story SFR - 1997 UBC	Plan: #450	1998
New	Approved Basic #98-110000BP	Two Story SFR - 1997 UBC	Plan: #450	1998
New	Approved Basic #98-109998BP	Two Story SFR - 1997 UBC	Plan: #450	1998
New	Approved Basic #98-109999BP	Two Story SFR - 1997 UBC	Plan: #450	1998
New	Approved Basic #98-109999BP	Two Story SFR - 1997 UBC	Plan: #450	1998
New	Approved Basic #98-110000BP	Two Story SFR - 1997 UBC	Plan: #450	1998
New	Approved Basic #98-109998BP	Two Story SFR - 1997 UBC	Plan: #450	1998
New	Approved Basic #98-109999BP	Two Story SFR - 1997 UBC	Plan: #450	1998
New	Approved Basic #98-109999BP	Two Story SFR - 1997 UBC	Plan: #450	1998
New	Approved Basic #98-110000BP	Two Story SFR - 1997 UBC	Plan: #450	1998
New	Approved Basic #98-109999BP	Two Story SFR - 1997 UBC	Plan: #450	1998
New	Approved Basic #98-109999BP	Two Story SFR - 1997 UBC	Plan: #450	1998
New	48x27, 1998 Golden West			1998
New	14 x 56 1999 Liberator			1998
New	14 x 66 1999 Glen Oakes			1998
New	Approved Basic #98-106859BP	Plan #1607 Two Story SFR - 1997 UBC		1998
New	Approved Basic #98-106869BP	Plan #2216 Two Story SFR - 1997 UBC		1998
New	Approved Basic #98-106867BP	Two Story SFR - 1997 UBC	Plan #1983	1998
New	Approved Basic #98-106867BP	(4 Bedroom) Two Story SFR - 1997 UBC		1998
New	Approved Basic #98-106869BP	Plan #2216 Two Story SFR - 1997 UBC		1998
New	Approved Basic #98-106871BP	Two Story SFR - 1997 UBC		1998
New	Approved Basic #98-106862BP	(4 Bedroom w/opt. 5th bedroom) Two Story SFR - 1997 UBC		1998
New	Approved Basic #98-106871BP	Two Story SFR - 1997 UBC		1998
New	Approved Basic #98-106867BP	(4 Bedroom) Two Story SFR - 1997 UBC		1998
New	Approved Basic #98-106859BP	Plan #1607 Two Story SFR - 1997 UBC		1998
New	Two Story SFR - 1997 UBC	Plan: #1771		1998
New	Approved Basic #98-106867BP	(4 Bedroom) Two Story SFR - 1997 UBC		1998
New	Approved Basic #98-106862BP	(4 Bedroom w/opt. 5th bedroom) Two Story SFR - 1997 UBC		1998
New	Approved Basic #98-106871BP	Two Story SFR - 1997 UBC		1998
New	Approved Basic #98-106867BP	(4 Bedroom) Two Story SFR - 1997 UBC		1998
New	Approved Basic #98-106871BP	Two Story SFR - 1997 UBC		1998
New	Approved Basic #98-106859BP	Plan #1607 Two Story SFR - 1997 UBC		1998
New	27x60, 1998 Fleetwood			1998
New	Two Story SFR - 1994 UBC	Plan #2093		1998
New	1792 sf daylight rambler w/859 sf unfinished basement and 1627 sf attached garage and 336 sf			1998
New	Two-story SFR w/fin basement & attached garage			1998
New	Approved Basic #98-106871BP	Two Story SFR - 1997 UBC		1998
New	Approved Basic #98-106865BP	(5 Bedroom) Two Story SFR - 1997 UBC		1998

Accessory Dwelling Units

Index # - File Name: 1.0022 - Single Family Dwellings Data\_Snohomish County.pdf

New	Approved Basic #98-106871BP	Two Story SFR - 1997 UBC		1998
New	Approved Basic #98-106859BP		Plan #1607 Two Story SFR - 1997 UBC	1998
New	Approved Basic #98-106871BP	Two Story SFR - 1997 UBC		1998
New	Approved Basic #98-106867BP	(4 Bedroom) Two Story SFR - 1997 UBC		1998
New	Approved Basic #98-106865BP	(5 Bedroom) Two Story SFR - 1997 UBC		1998
New	Approved Basic #98-106866BP	(3 Bedroom) Two Story SFR - 1997 UBC		1998
New	Approved Basic #98-106871BP	Two Story SFR - 1997 UBC		1998
New	Approved Basic #98-106867BP	(4 Bedroom) Two Story SFR - 1997 UBC		1998
New	Approved Basic #98-106871BP	Two Story SFR - 1997 UBC		1998
New	Approved Basic #98-106867BP	(4 Bedroom) Two Story SFR - 1997 UBC		1998
New	Approved Basic #98-106871BP	Two Story SFR - 1997 UBC		1998
New	Approved Basic #98-106869BP		Plan #2216 Two Story SFR - 1997 UBC	1998
New	Approved Basic #98-106859BP		Plan #1607 Two Story SFR - 1997 UBC	1998
New	Approved Basic #98-106867BP	(4 Bedroom) Two Story SFR - 1997 UBC		1998
New	Approved Basic #98-106871BP	Two Story SFR - 1997 UBC		1998
New	Approved Basic #98-106866BP	(3 Bedroom) Two Story SFR - 1997 UBC		1998
New	Approved Basic #98-106869BP		Plan #2216 Two Story SFR - 1997 UBC	1998
New	Approved Basic #98-150505BP		Plan: 1771 Two Story SFR - 1997 UBC	1998
New	Two Story SFR - 1997 UBC		Plan #2050	1998
New	Two Story SFR - 1997 UBC		Plan #1607	1998
New	Two Story SFR - 1997 UBC		Plan #1983	1998
New	Approved Basic #98-106862BP	Two Story SFR - 1997 UBC		Plan #2111 1998
New	Approved Basic #98-106859BP		Plan #1607 Two Story SFR - 1997 UBC	1998
New	Two Story SFR - 1997 UBC		Plan #1396	1998
New	Approved Basic #98-106871BP	Two Story SFR - 1997 UBC		Plan #1741 1998
New	Approved Basic #98-106867BP	Two Story SFR - 1997 UBC		Plan #1983 1998
New	Approved Basic #98-106871BP	Two Story SFR - 1997 UBC		Plan #1741 1998
New	Approved Basic #98-106869BP		Plan #2216 Two Story SFR - 1997 UBC	1998
New	Approved Basic #98-106871BP	Two Story SFR - 1997 UBC		Plan #1741 1998
New	Approved Basic #98-106867BP	Two Story SFR - 1997 UBC		Plan #1983 1998
New	Approved Basic #98-106865BP	Two Story SFR - 1997 UBC		Plan #1955 1998
New	Approved Basic #98-106866BP	(3 Bedroom) Two Story SFR - 1997 UBC		1998
New	Approved Basic #98-106865BP	(5 Bedroom) Two Story SFR - 1997 UBC		1998
New	Approved Basic #98-106871BP	Two Story SFR - 1997 UBC		1998
New	Approved Basic #98-106866BP	(3 Bedroom) Two Story SFR - 1997 UBC		1998
New	Approved Basic #98-106865BP	Two Story SFR - 1997 UBC		Plan #1955 1998
New	Approved Basic #98-106867BP	Two Story SFR - 1997 UBC		Plan #1983 1998
New	Approved Basic #98-106871BP	Two Story SFR - 1997 UBC		Plan #1741 1998
New	Two-story SFR w/unfin basement & attached garage			1998
New	1996 sf 2-story w/1442 sf unfinished basement w/576 sf garage and 182 sf covered deck/porch			1998
New	2033 sf Rambler with attached garage and covered porch - 1997 UBC			1998
New	Two-story SFR w/attached garage			1998
New	30x66, 1998 Golden West			1998
New	2 Story with 3- car garage - 1997 UBC			1998
New	2 Story SFR with attached garage and covered porch - 1997 UBC			1998
New	1998 - Fleetwood 27 x 66 .			1998
New	844 s.f. sfr over 3 car garage			1998



Accessory Dwelling Units

Index # - File Name: 1.0022 - Single Family Dwellings Data\_Snohomish County.pdf

New	Two Story SFR - 1997 UBC	0 lot line structure	1998
New	Two Story SFR - 1997 UBC	0 lot line structure	1998
New	Two Story SFR - 1997 UBC	0 lot line structure	1998
New	Two Story SFR - 1997 UBC	0 lot line structure	1998
New	Two Story SFR - 1997 UBC	0 lot line structure	1998
New	Two Story SFR - 1997 UBC	0 lot line structure	1998
New	Two Story SFR - 1997 UBC	0 lot line structure	1998
New	Two Story SFR - 1997 UBC	0 lot line structure	1998
New	27x44 (1998) Palm Harbor		1998
New	1344 s.f. sfr with 648 finished basement & 2 car garage		1998
New	Approved Basic #98-110337BP	Plan #1928 Two Story SFR with Attac	1998
New	SFR with Basement and Attached Garage		1998
New	Approved Basic #98-108359BP	(3 Bedroom) Two Story SFR - 1997 L	1998
New	SFR with Unfinished Basement and Attached Garage		1998
New	1424 sf Rambler w/875 sf finished basement and 560 sf garage		1998
New	Rambler Style SFR - 1997 UBC	Plan #1340	1998
New	Rambler Style SFR - 1997 UBC	Plan #1200	1998
New	Split level SFR w/finished lower floor - 1997 UBC	Plan #1405-S	1998
New	SFR w/finished lower floor - 1997 UBC	Plan #8808	1998
New	Approved Basic #98-116233BP	Tri level SFR w/finished lower floor - 1997 UBC	Plar 1998
New	Approved Basic #98-116713BP	Plan: 1765 Two Story SFR - 1997 U	1998
New	Approved Basic #98-116234BP	SFR w/finished lower floor - 1997 UBC	Pl 1998
New	Approved Basic #98-116233BP	Tri level SFR w/finished lower floor - 1997 UBC	Plar 1998
New	Approved Basic #98-116235BP	Plan 8812 Tri-Level SFR - 199'	1998
New	Tri level SFR w/finished lower floor - 1997 UBC	Plan #1532	1998
New	Rambler Style SFR - 1997 UBC	Plan #1280	1998
New	SFR w/finished lower floor - 1997 UBC	Plan #8812	1998
New	Split level SFR w/finished lower floor - 1997 UBC	Plan #1450-S	1998
New	SFR w/finished lower floor - 1997 UBC	Plan #1744	1998
New	Rambler Style SFR - 1997 UBC	Plan #1340	1998
New	Approved Basic #98-116713BP	Plan: 1765 Two Story SFR - 1997 UB	1998
New	Tri level SFR w/finished lower floor - 1997 UBC	Plan #1532	1998
New	Two Story SFR - 1997 UBC	Plan #1765	1998
New	SFR w/finished lower floor - 1997 UBC	Plan #1744	1998
New	SFR w/finished lower floor - 1997 UBC	Plan #8812	1998
New	SFR w/finished lower floor - 1997 UBC	Plan #8808	1998
New	Approved Basic #98-116710BP	Plan: 1450 S SFR w/finished basement - 1997	1998
New	Two Story SFR - 1997 UBC	Plan: 1784	1998
New	Two Story SFR - 1997 UBC	Plan: 1528	1998
New	Two Story SFR - 1997 UBC	Plan: 1528	1998
New	Approved Basic #98-107737	Plan # Spruce SFR w/finished low	1998
New	Approved Basic #98-107733BP	Plan # Hickory Two Story SFR - 199	1998
New	Approved Basic #98-107735	Plan # Aspen Two Story SFR - 1997	1998
New	Approved Basic #98-107735	Plan # Aspen Two Story SFR - 1997	1998
New	Approved Basic #98-107733BP	Plan # Hickory Two Story SFR - 199	1998
New	2 Story w/ 2 Car - 1997 UBC	Plan: #Hemlock	1998
New	Approved Basic #98-107735	Plan # Aspen Two Story SFR - 1997	1998

Accessory Dwelling Units

Index # - File Name: 1.0022 - Single Family Dwellings Data\_Snohomish County.pdf

New	Approved Basic #98-107737	Plan # Spruce	SFR w/finished lower	1998
New	Approved Basic #98-107733BP	Plan # Hickory	Two Story SFR - 199	1998
New	Approved Basic #98-107731BP	Plan # Hemlock	Two Story SFR - 199	1998
New	Two Story SFR - 1997 UBC	Plan # Rosewood		1998
New	Approved Basic #98-107735	Plan # Aspen	Two Story SFR - 1997 U	1998
New	Approved Basic #98-107737	Plan # Spruce	SFR w/finished lower	1998
New	Approved Basic #98-107731BP	Plan # Hemlock	Two Story SFR - 199	1998
New	2-Story SFR w/attached garage	Plan: Aspen	1997-UBC 1997-WSEC	1998
New	Approved Basic #98-107737	Plan # Spruce	SFR w/finished lower	1998
New	2-Story SFR w/attached garage	Plan: Hickory	1997-UBC, 1997-WSEC	1998
New	Approved Basic #98-107735	Plan # Aspen	Two Story SFR - 1997 U	1998
New	Split Level with finished basement and attached garage - 1997 UBC			1998
New	2-Story SFR w/attached Garage			1998
New	2-Story SFR w/attached garage			1998
New	Approved Basic #98-116233BP	Tri level SFR w/finished lower floor - 1997 UBC	Plan	1998
New	Approved Basic #98-109410BP	Plan: 1644	Split Level SFR - 1997 U	1998
New	Approved Basic #98-109408BP	Plan: 1705	SFR w/unfinished lower	1998
New	Approved Basic #98-109410BP	Plan: 1644	Split Level SFR - 1997 U	1998
New	Approved Basic #98-109410BP	Plan: 1644	Split Level SFR - 1997 U	1998
New	Approved Basic #98-109408BP	Plan: 1705	SFR w/unfinished lower	1998
New	Approved Basic #98-109410BP	Plan: 1644	Split Level SFR - 1997 U	1998
New	Approved Basic #98-109408BP	Plan: 1705	SFR w/unfinished lower	1998
New	Approved Basic #98-1094BP	Plan: 1644	Split Level SFR - 1997 UBC	1998
New	Approved Basic #98-109410BP	Plan: 1644	Split Level SFR - 1997 U	1998
New	Approved Basic #98-109410BP	Plan: 1644	Split Level SFR - 1997 U	1998
New	Approved Basic #98-109408BP	Plan: 1705	SFR w/unfinished lower	1998
New	Rambler Style SFR - 1997 UBC			1998
New	Approved Basic #98-109410BP	Plan: 1644	Split Level SFR - 1997 U	1998
New	Approved Basic #98-109408BP	Plan: 1705	SFR w/unfinished lower	1998
New	Approved Basic #98-109408BP	Plan: 1705	SFR w/unfinished lower	1998
New	Approved Basic #98-109410BP	Plan: 1644	Split Level SFR - 1997 U	1998
New	Rambler Style SFR - 1997 UBC	Plan: 809		1998
New	Approved Basic #98-103838BP	Zero Lot Line Structure - Two Story SFR - 1994 UBC	PI	1998
New	Approved Basic #98-103838BP	Zero Lot Line Structure - Two Story SFR - 1994 UBC	PI	1998
New	Approved Basic #98-107784BP	Plan: #Bldg. 3	Two Story SFR - 1997 U	1998
New	Approved Basic #98-107784BP	Plan: #Bldg. 3	Two Story SFR - 1997 U	1998
New	24 x 60 1978 Hillcrest			1998
New	Rambler w/unfin bsmt, loft & 3 car			1998
New	Single Story Duplex w/attached garages. - 1997 UBC			1998
New	Rambler Style Duplex - 1997 UBC			1998
New	2-Story, Split Level style SFR w/3-car garage			1998
New	Two-story log house			1998
New	One-story SFR w/attached garage			1998
New	Two Story SFR - 1997 UBC			1998
New	1998 Coach Corral 66 x 27			1998
New	14 x 66 - 1997 - Liberty Mobile Home			1998
New	Two-story SFR w/attached garage			1998

Accessory Dwelling Units

Index # - File Name: 1.0022 - Single Family Dwellings Data\_Snohomish County.pdf

New	2-Story SFR w/attached garage	0 Lot Line Structure	1997-UBC	1997-W	1998
New	Approved Basic #98-107784BP	Plan: #Bldg. 3	Two Story SFR - 1997 U		1998
New	2-Story SFR w/attached garage	0 Lot Line Structure	1997 - UBC	1997 - W	1998
New	Approved Basic #98-107786BP	0 Lot Line Structure	Two Story SFR - 199		1998
New	2-Story SFR w/attached garage	1997 - UBC	1997 - WSEC		1998
New	Approved Basic #98-108502BP	Plan: Building 2	2-Story SFR - 199		1998
New	Approved Basic #98-107786BP	0 Lot Line Structure	Two Story SFR - 199		1998
New	Approved Basic #98-107786BP	0 Lot Line Structure	Two Story SFR - 199		1998
New	Split w/2 car				1998
New	1996 Marlette 28 x 66				1998
New	1712 s.f. sfr with 1662 unfinished basement & 2 car garage				1998
New	Two Story SFR - 1997 UBC	Plan #1715			1998
New	Approved Basic #98-109993BP	Builders #1715	2-Story SFR w/attached g		1998
New	2006 2-story w/748 sf garage and 28 sf covered deck/porch				1998
New	2 Story w/2 Car				1998
New	2093 sf 2-story w/685 sf garage and 32 sf covered deck/porch				1998
New	2 story sfr with 2 car garage				1998
New	44 x 28 Fleetwood - 1988				1998
New	SFR w/finished basement - 1997 UBC	Plan: 1574			1998
New	2-Story SFR w/attached 3-car garage	1997-UBC	1997-WSEC		1998
New	SFRw/ attached garage				1998
New	Approved Basic 98-150527BP	2 Story w/3 Car			1998
New	2 story sfr with 2 car garage				1998
New	Basement Rambler style SFR w/attached garage	Retaining walls integrated w/foundation on R			1998
New	Approved Basic #98-110348BP	Plan: #2005	2006 2-story w/748 sf g;		1998
New	14 x 66 - 1978 - Fuqua				1998
New	Rambler style SFR with attached garage				1998
New	1986 40 x 27 Factory				1998
New	Approved Basic #98-109888BP	Two Story SFR - 1997 UBC		Plan: #237	1998
New	Two Story SFR -1997 UBC	Plan: #2539 A,B,C			1998
New	2 story SFR w/ attached garage				1998
New	Two Story SFR - 1997 UBC	Plan: #2375 Elv. A,B,C			1998
New	Approved Basic #98-109884BP	Two Story SFR -1997 UBC		Plan: #253	1998
New	Approved Basic #98-109888BP	Two Story SFR - 1997 UBC		Plan: #237	1998
New	Approved Basic #98-109884BP	Two Story SFR -1997 UBC		Plan: #253	1998
New	2 story sfr with basement & 2 car garage				1998
New	1999, 40x23.5 Fleetwood				1998
New	Approved Basic #98-109887BP	Two Story SFR -1997 UBC		Plan: #284	1998
New	Approved Basic #98-109887BP	Two Story SFR -1997 UBC		Plan: #284	1998
New	Approved Basic #98-109884BP	Two Story SFR -1997 UBC		Plan: #253	1998
New	Approved Basic #98-109888BP	Two Story SFR - 1997 UBC		Plan: #237	1998
New	Approved Basic #98-109888BP	Two Story SFR - 1997 UBC		Plan: #237	1998
New	Approved Basic #98-109887BP	Two Story SFR -1997 UBC		Plan: #284	1998
New	Two Story SFR -1997 UBC	1997 WSEC	Plan: #2846 A,B,C		1998
New	Approved Basic #98-109886BP	Two Story SFR -1997 UBC		Plan: #208	1998
New	Approved Basic #98-109888BP	Two Story SFR - 1997 UBC		Plan: #237	1998
New	Approved Basic #98-109884BP	Two Story SFR -1997 UBC		Plan: #253	1998



Accessory Dwelling Units

Index # - File Name: 1.0022 - Single Family Dwellings Data\_Snohomish County.pdf

New	2 story SFR		1998
New	2 story SFR with loft		1998
New	2 Story w/ 3 Car		1998
New	Approved Basic #98-108977BP	Plan #1344 R Two Story SFR - 1997 UBC	1998
New	1998 28 x 60 Fleetwood		1998
New	Split w/2 car - 1997 UBC		1998
New	2-Story SFR w/attached garage.		1998
New	2270 2-story w/628 sf garage and 372 sf covered deck		1998
New	2270 2-story w/628 sf garage and 372 sf covered deck		1998
New	SFR w/finished lower floor - 1997 UBC	Plan #2195	1998
New	Approved Basic #98-109315BP	Split SFR w/finished lower floor - 1997 UBC	1998
New	Approved Basic #98-109303BP	Split SFR w/finished lower floor - 1997 UBC	1998
New	Two Story SFR - 1997 UBC	Plan #1927	1998
New	Two Story SFR - 1997 UBC	Plan #1905	1998
New	Two Story SFR - 1997 UBC	Plan #2084	1998
New	Approved Basic #98-110175BP	Plan #1927 Two Story SFR - 1997 U	1998
New	Approved Basic #98-109303BP	Split SFR w/finished lower floor - 1997 UBC	1998
New	Approved Basic #98-109315BP.	STOP WORK 4/1/99 PER CHRIS GRIFFITH Split SFR w/finished l	1998
New	Approved Basic #98-109315BP	Split SFR w/finished lower floor - 1997 UBC	1998
New	Approved Basic #98-109303BP	Split SFR w/finished lower floor - 1997 UBC	1998
New	Approved Basic #98-110176BP	Plan #2084 Two Story SFR - 1997 U	1998
New	Approved Basic #98-109303BP	Split SFR w/finished lower floor - 1997 UBC	1998
New	Approved Basic #98-109315BP	Split SFR w/finished lower floor - 1997 UBC	1998
New	Approved Basic #98-109315BP	Split SFR w/finished lower floor - 1997 UBC	1998
New	Two Story SFR - 1997 UBC	Plan: 2080	1998
New	Approved Basic #98-110176BP	Plan #2084 Two Story SFR - 1997 U	1998
New	Approved Basic #98-109303BP	Split SFR w/finished lower floor - 1997 UBC	1998
New	Approved Basic #98-109315BP	Split SFR w/finished lower floor - 1997 UBC	1998
New	Approved Basic #98-109303BP	Split SFR w/finished lower floor - 1997 UBC	1998
New	Approved Basic #98-109303BP	Split SFR w/finished lower floor - 1997 UBC	1998
New	Approved Basic #98-109303BP	Split SFR w/finished lower floor - 1997 UBC	1998
New	Approved Basic #98-109303BP	Split SFR w/finished lower floor - 1997 UBC	1998
New	Two Story SFR - 1997 UBC	Plan #1927	1998
New	Two Story SFR w/unfinished basement - 1997 UBC	Plan #2614	1998
New	SFR with Attached Garage		1998
New	Single Story Duplex with Attached Garage		1998
New	Split Level SFR - 1997 UBC	Plan #1885	1998
New	2 Story SFR with attached garage	1997-UBC, 1997-WSEC	1998
New	12 x 60 1966 Nashua		1998
New	2-Story SFR with attached garage - 1997 UBC		1998
New	2- Story SFR with attached garage - 1997 UBC		1998
New	Two-story SFR w/attached garage		1998
New	Two-story SFR w/attached garage		1998
New	800 sq. ft. accessory apartment - 1997 UBC		1998
New	Approved Basic #98-116553BP	Plan: Kimberly IV Two Story SFR	1998
New	Approved Basic #98-116554BP	Plan: Michelle IV Two Story SFR -	1998
New	SFR w/finished lower floor - 1997 UBC		1998
New	Approved Basic #98-116554BP	Plan: Michelle IV Two Story SFR -	1998

Accessory Dwelling Units

Index # - File Name: 1.0022 - Single Family Dwellings Data\_Snohomish County.pdf

New	27x61 (1998) Fleetwood		1998
New	Rambler with daylighted and attached garage - 1997 UBC		1998
New	Approved Basic #98-108927BP	Plan 1552 Two Story SFR - 1997 UBC	1998
New	40 x 60 1999 Silvercrest		1998
New	66 x26 8 , 1998 Fleetwood		1998
New	2 Story w/2 Car		1998
New	2449 sf 2-story w/570 sf garage and 175 sf covered deck/porch		1998
New	Rambler with Attached Garage		1998
New	Two Story SFR with Attached Garage		1998
New	Approved Basic #98-116167BP	Two Story SFR - 1997 UBC	1998
New	Approved Basic #98-116263BP	Plan #2188 Two Story SFR - 1997 UBC	1998
New	32 x 32 SFR		1998
New	2 story SFR w/ attached garage		1998
New	2 story w/2car garage		1998
New	Approved Basic #98-110146-BP	Split SFR w/finished lower floor - 1997 UBC	1998
New	2 story with attached garage & covered porch - 1997 UBC		1998
New	Approved Basic #98-110504BP	Split Level SFR with attached garge	1998
New	2 story SFR with attached garage		1998
New	Approved Basic #98-104672BP	Plan #2085 Two Story SFR - 1997	1998
New	Approved Basic #98-110146-BP	Split SFR w/finished lower floor - 1997 UBC	1998
New	Approved Basic #98-104672BP	Plan #2085 Two Story SFR - 1997	1998
New	Approved Basic #98-110146-BP	Split SFR w/finished lower floor - 1997 UBC	1998
New	2 story SFR w/ attached garage		1998
New	Approved Basic 98-150515BP	Two Story SFR - 1997 UBC	1998
New	Approved Basic #98-110504BP	Split Level SFR with attached garage 1997 UBC	1998
New	2 Story with daylighted and attached garage - 1997 UBC		1998
New	Two-story SFR w/attached garage - 1997 UBC		1998
New	Approved Basic #98-116263BP	Plan #2188 Two Story SFR - 1997 UBC	1998
New	Two Story SFR - 1997 UBC	Plan # Unit A	1998
New	Two Story SFR - 1997 UBC	Plan: Unit A	1998
New	Approved Basic #98-110147BP	Builders Plan #Unit A Two Story SFR - 1997	1998
New	Approved Basic #98-110147BP	Builders Plan #Unit A Two Story SFR - 1997	1998
New	two Story SFR - 1997 UBC	Builders Plan : Unit C	1998
New	Two Story SFR - 1997 UBC	Builders Plan: Unit B	1998
New	Approved Basic #98-110147BP	Builders Plan #Unit A Two Story SFR - 1997	1998
New	Approved Basic #98-110147BP	Builders Plan #Unit A Two Story SFR - 1997	1998
New	DO NOT PROCEED. NSF CHECK 11/4/98. QUESTIONS CALL KATIE X2226.	Approved Basic #98-1:	1998
New	Approved Basic #98-110147BP	Builders Plan #Unit A Two Story SFR - 1997	1998
New	2798 sf 2-story w/580 sf garage and 20 sf covered deck/porch		1998
New	One story duplex with two 2 car garages		1998
New			1998
New	Rambler style SFR with attached garage	Approved Basic #97-111601BP	1998
New	28 x 52 1997 Golden West NW52		1998
New	28 x 48 Golden West 1997		1998
New	1998 Golden West 27 x 52		1998
New	1998 Golden West 28 x 66		1998
New	1998 Golden West 28 x 66		1998

Accessory Dwelling Units

Index # - File Name: 1.0022 - Single Family Dwellings Data\_Snohomish County.pdf

New	Two Story SFR with Basement and Attached Garage		1998
New	2 story sfr		1998
New	Approved Basic #98-105056BP	Plan #2130 B Two Story SFR - 1994 UB	1998
New	2 story sfr with 2 car garage		1998
New	Approved Basic #98-105056BP	Plan #2130 B Two Story SFR - 1994 UB	1998
New	2 Story w/2 Car		1998
New	Approved Basic #98-105053BP	Plan #2250 A/2 Two Story SFR - 1994	1998
New	Approved Basic #98-105056 BP	Two Story SFR - 1994 UBC	1998
New	Two Story SFR - 1994 UBC	Plan: 2241	1998
New	2 story sfr with 2 car garage		1998
New	Two Story SFR - 1994 UBC	Plan:2250	1998
New	Approved Basic #96-105448BP	Two Story SFR - 1994 UBC	1998
New	Approved Basic #96-105448BP	Two Story SFR - 1994 UBC	1998
New	Approved Basic #96-105448BP	Two Story SFR - 1994 UBC	1998
New	Approved Basic #98-105053BP	Plan #2250 A/2 Two Story SFR - 1994	1998
New	Approved Basic #98-105053BP	Plan #2250 A/2 Two Story SFR - 1994 UBC	1998
New	Two Story SFR - 1994 UBC	Plan: 2115	1998
New	2 story sfr w/2 car garage		1998
New	Two Story SFR - 1994 UBC		1998
New	Approved Basic #95-109379BP	Plan 1936 Two Story SFR - 1994 UBC	1998
New	Approved Basic #97-111629BP	Plan #2415 A/3 Two Story SFR - 1994 UBC	1998
New	Two Story SFR w/unfinished basement - 1994 UBC		1998
New	Approved Basic #98-101820BP	Plan - Brittany-3- Revised Two Story SFR - 19	1998
New	Two Story SFR - 1994 UBC		1998
New	2 story w/3 car		1998
New	Approved Basic #98-102264BP	Plan #2445 Two Story SFR - 199	1998
New	Approved Basic #98-100850BP	Plan: 2368/3 Two Story SFR - 1994 UBC	1998
New	Two Story SFR - 1994 UBC	Plan: Brittany 3-Revised	1998
New	Approved Basic #97-111529BP	Plan #2120 Two Story SFR - 1994 UBC	1998
New	Approved Basic #98-102074BP	Plan #1917 Two Story SFR - 1994	1998
New	Approved Basic #98-102074BP	Plan #1917 Two Story SFR - 1994	1998
New	Approved Basic #95-110544BP	Plan: 2137 2/3 2 story SFR-2 or 3 car garage- 19	1998
New	2 Story w/3 Car Approved Basic 98-101612BP		1998
New	Approved Basic #97-111017BP	Plan #1938 Two Story SFR - 1994	1998
New	Approved Basic #95-110544BP	Plan: 2137 2/3 2 story SFR-2 or 3 car garage- 19	1998
New	Approved Basic #96-100763BP	Two Story SFR - 1994 UBC (2/3 car option)	1998
New	Approved Basic #97-105350BP	Plan #2210 Two Story SFR - 1994 UBC	1998
New	Approved Basic #97-111529BP	Plan #2120 Two Story SFR - 1994 UBC	1998
New	Approved Basic #95-110544BP	Plan: 2137 2/3 2 story SFR-2 or 3 car garage- 19	1998
New	Approved Basic 98-103087BP	2 Story w/3 Car	1998
New	Approved Basic #97-106045BP	Plan #1887 Two Story SFR - 1994 UBC	1998
New	Approved Basic #95-110544BP	Plan: 2137 2/3 2 story SFR-2 or 3 car garage- 19	1998
New	Approved Basic #98-100850BP	Plan: 2368/3 Two Story SFR - 1994 UBC	1998
New	Approved Basic #97-105350BP	Plan #2210 Two Story SFR - 1994 UBC	1998
New	2 Story w/3 Car Approved Basic 98-103087BP		1998
New	Approval Basic #97-105892BP	Plan #2254 Two Story SFR - 1994 UBC	1998
New	Approved Basic #97-105350BP	Plan #2210 Two Story SFR - 1994 UBC	1998

Accessory Dwelling Units

Index # - File Name: 1.0022 - Single Family Dwellings Data\_Snohomish County.pdf

New	Approval Basic #97-105892BP	Plan #2254	Two Story SFR - 1994 UBC	1998
New	Approved Basic #97-111529BP	Plan #2120	Two Story SFR - 1994 UBC	1998
New	Approved Basic #96-103802BP	Plan: #1884 - 2/3	Two Story SFR - 1994 UBC	1998
New	Approved Basic #97-105350BP	Plan #2210	Two Story SFR - 1994 UBC	1998
New	Approved Basic #95-110544BP	Plan: 2137 2/3	2 story SFR-2 or 3 car garage- 19	1998
New	Two Story SFR - 1994 UBC			1998
New	Approved Basic #96-103802BP	Plan: #1884 - 2/3	Two Story SFR - 1994 UBC	1998
New	Two Story SFR - 1994 UBC			1998
New	Approved Basic #98-100850BP	Plan: 2368/3	Two Story SFR - 1994 UBC	1998
New	Approved Basic #97-105350BP	Plan #2210	Two Story SFR - 1994 UBC	1998
New	Approval Basic #97-105892BP	Plan #2254	Two Story SFR - 1994 UBC	1998
New	Two Story SFR - 1994 UBC	Plan #2360		1998
New	Approved Basic #96-103802BP	Plan: #1884 - 2/3	Two Story SFR - 1994 UBC	1998
New	Approved Basic #97-111017BP	Plan #1938	Two Story SFR - 1994 UBC	1998
New	2-Story SFR w/attached garage.			1998
New	Approved Basic #98-100580BP	Plan: #1904	Two Story SFR w/unfinished basem	1998
New	Two Story SFR w/unfinished basement - 1994 UBC	Plan 2137/DB		1998
New	Approved Basic #97-110034BP	Plan #2154	Two Story SFR - 1994 UBC	1998
New	Approved Basic #97-111529BP	Plan #2120	Two Story SFR - 1994 UBC	1998
New	2-Story SFR w/attached garage.			1998
New	2 story sfr with 2 car garage			1998
New	2 Story w/3 Car Approved Basic 98-101612BP			1998
New	Approved Basic #97-111529BP	Plan #2120	Two Story SFR - 1994 UBC	1998
New	Approved Basic #95-110544BP	Plan: 2137 2/3	2 story SFR-2 or 3 car	1998
New	Two Story SFR - 1994 UBC	Plan #2374		1998
New	Approved Basic #97-105350BP	Plan #2210	Two Story SFR - 1994 UBC	1998
New	42 X 52 1997 Palm Harbor			1998
New	Approved Basic #97-111568BP	Plan #5503	Two Story SFR - 1994 UBC	1998
New	Approved Basic #97-111568BP	Plan #5503	Two Story SFR - 1994 UBC	1998
New	Approved Basic #97-111568BP	Plan #5503	Two Story SFR - 1994 UBC	1998
New	Two Story SFR - 1994 UBC	Plan #HP19		1998
New	Two Story SFR - 1997 UBC			1998
New	Two Story SFR - 1994 UBC	Plan #HP21		1998
New	Two Story SFR - 1997 UBC	Plan #HP22		1998
New	2 Story SFR w/ attached garage			1998
New	Two Story SFR - 1997 UBC	Plan #HP24		1998
New	Two Story SFR - 1994 UBC			1998
New	Two Story SFR - 1994 UBC	Plan: #26HP		1998
New	Two Story SFR - 1994 UBC	Plan: 27HP		1998
New	Two Story SFR - 1994 UBC	Plan #28HP		1998
New	Approved Basic #97-111572BP	Plan #7003	Two Story SFR - 1994 UBC	1998
New	Approved Basic #97-111571BP	Plan #7002	Two Story SFR - 1994 UBC	1998
New	Rambler style SFR - 1994 UBC			1998
New	Two Story SFR - 1997 UBC	Plan: HP02		1998
New	Two Story SFR - 1994 UBC	Per voided permit 98-102273.	Plan HP03	1998
New	Two Story SFR - 1994 UBC	Plan #HP4		1998
New	Two Story SFR - 1994 UBC	PLan HP05		1998







Accessory Dwelling Units

Index # - File Name: 1.0022 - Single Family Dwellings Data\_Snohomish County.pdf

New	Approved Basic #97-111563BP	Plan # 4500/Plan 2	Two Story SFR - 1994 UBC	1998
New	Approved Basic #97-111563BP	Plan # 4500/Plan 2	Two Story SFR - 1994 UBC	1998
New	Approved Basic #97-111563BP	Plan # 4500/Plan 2	Two Story SFR - 1994 UBC	1998
New	Approved Basic #97-111563BP	Plan # 4500/Plan 2	Two Story SFR - 1994 UBC	1998
New	Approved Basic #97-111560BP	Plan: 4500/Plan 3	Two Story SFR - 1994 UBC	1998
New	Approved Basic #97-111560BP	Plan: 4500/Plan 3	Two Story SFR - 1994 UBC	1998
New	Approved Basic #97-111563BP	Plan # 4500/Plan 2	Two Story SFR - 1994 UBC	1998
New	Approved Basic #97-111561BP	Plan: 4500/Plan 1	Two Story SFR - 1994 UBC	1998
New	Approved Basic #97-111560BP	Plan: 4500/Plan 3	Two Story SFR - 1994 UBC	1998
New	Approved Basic #97-111560BP	Plan: 4500/Plan 3	Two Story SFR - 1994 UBC	1998
New	Approved Basic #97-111563BP	Plan # 4500/Plan 2	Two Story SFR - 1994 UBC	1998
New	Approved Basic #97-111563BP	Plan # 4500/Plan 2	Two Story SFR - 1994 UBC	1998
New	Approved Basic #97-111560BP	Plan: 4500/Plan 3	Two Story SFR - 1994 UBC	1998
New	Approved Basic #97-111560BP	Plan: 4500/Plan 3	Two Story SFR - 1994 UBC	1998
New	Approved Basic #97-111560BP	Plan: 4500/Plan 3	Two Story SFR - 1994 UBC	1998
New	Approved Basic #97-111560BP	Plan: 4500/Plan 3	Two Story SFR - 1994 UBC	1998
New	Approved Basic #97-111563BP	Plan # 4500/Plan 2	Two Story SFR - 1994 UBC	1998
New	Approved Basic #97-111560BP	Plan: 4500/Plan 3	Two Story SFR - 1994 UBC	1998
New	Approved Basic #97-111560BP	Plan: 4500/Plan 3	Two Story SFR - 1994 UBC	1998
New	Approved Basic #97-111560BP	Plan: 4500/Plan 3	Two Story SFR - 1994 UBC	1998
New	Approved Basic #97-111560BP	Plan: 4500/Plan 3	Two Story SFR - 1994 UBC	1998
New	Approved Basic #97-111560BP	Plan: 4500/Plan 3	Two Story SFR - 1994 UBC	1998
New	Approved Basic #97-111563BP	Plan # 4500/Plan 2	Two Story SFR - 1994 UBC	1998
New	Approved Basic #97-111560BP	Plan: 4500/Plan 3	Two Story SFR - 1994 UBC	1998
New	Approved Basic #97-111560BP	Plan: 4500/Plan 3	Two Story SFR - 1994 UBC	1998
New	Approved Basic #97-111560BP	Plan: 4500/Plan 3	Two Story SFR - 1994 UBC	1998
New	Approved Basic #97-111563BP	Plan # 4500/Plan 2	Two Story SFR - 1994 UBC	1998
New	Approved Basic #97-111563BP	Plan # 4500/Plan 2	Two Story SFR - 1994 UBC	1998
New	Approved Basic #97-111560BP	Plan: 4500/Plan 3	Two Story SFR - 1994 UBC	1998
New	Approved Basic #97-111568BP	Plan #5503	Two Story SFR - 1994 UBC	1998
New	Approved Basic #97-111567BP	Plan #5502	Two Story SFR - 1994 UBC	1998
New	Approved Basic #97-111568BP	Plan #5503	Two Story SFR - 1994 UBC	1998
New	Approved Basic #97-111568BP	Plan #5503	Two Story SFR - 1994 UBC	1998
New	Approved Basic #97-111567BP	Plan #5502	Two Story SFR - 1994 UBC	1998
New	Approved Basic #97-111568BP	Plan #5503	Two Story SFR - 1994 UBC	1998
New	Approved Basic #97-111567BP	Plan #5502	Two Story SFR - 1994 UBC	1998
New	Approved Basic #97-111565BP	Plan #5501	Two Story SFR - 1994 UBC	1998
New	Approved Basic #97-111568BP	Plan #5503	Two Story SFR - 1994 UBC	OPTION Approved
New	Approved Basic #97-111567BP	Plan #5502	Two Story SFR - 1994 UBC	1998
New	Approved Basic #97-111568BP	Plan #5503	Two Story SFR - 1994 UBC	1998
New	Approved Basic #97-111568BP	Plan #5503	Two Story SFR - 1994 UBC	1998
New	Approved Basic #97-111567BP	Plan #5502	Two Story SFR - 1994 UBC	1998
New	Approved Basic #97-111571BP	Plan #7002	Two Story SFR - 1994 UBC	1998
New	2353 sf SFR w/attached garage			1998
New	Approved Basic #97-109187BP	Plan 5018/5118	Two Story SFR - 1994 UBC	1998
New	Approved Basic #97-111733BP	Plan #5211/5311	Two Story SFR - 1994 UBC	1998
New	Approved Basic #97-111732BP	Plan: #5017/5117	Two Story SFR - 1994 UBC	1998



Accessory Dwelling Units

Index # - File Name: 1.0022 - Single Family Dwellings Data\_Snohomish County.pdf

New	Approved Basic #97-109187BP	Plan 5018/5118	Two Story SFR - 1994 UBC	1998
New	Approved Basic #97-111375 BP	Plan #5019/5119	Two Story SFR - 1994 UBC	1998
New	Approved Basic #97-105339BP	Plan #1901	Two Story SFR - 1994 UBC	1998
New	Approved Basic 98-102356-BP	Plan 11286	One story SFR w/attached garage	1998
New	Approved Basic #98-102441BP	Plan #1020	Rambler Style SFR - 1994 UBC	1998
New	1998 Guerdon S7-50534 28 x 50			1998
New	2-Story SFR with attached garage -1994 UBC			1998
New	Two Story SFR - 1994 UBC	Plan: #2587		1998
New	Approved Basic #96-110600BP	Plan #1833 w/bonus	Two Story SFR - 1994 UBC	1998
New	Approved Basic #96-110600BP	Plan #1833 w/bonus	Two Story SFR - 1994 UBC	1998
New	Approved Basic #96-110602BP	Plan 2031w/bonus	Two Story SFR - 1994 UBC	1998
New	Approved Basic #96-110600BP	Plan #1833 w/bonus	Two Story SFR - 1994 UBC	1998
New	2-Story SFR w/attached garage	1997-UBC	1997-WSEC	1998
New	Rambler with attached garage - 1997 UBC			1998
New	Approved Basic #98-109153BP	Plan 2031	Two Story SFR - 1997 UI	1998
New	Approved Basic #96-110604BP	Plan 2156	Two Story SFR - 1994 UBC	1998
New	Approved Basic #96-110602BP	Plan 2031w/bonus	Two Story SFR - 1994 UBC	1998
New	Two Story SFR - 1994 UBC			1998
New	Rambler w/daylight unfin basement & 2 car garage			1998
New	Approved Basic #96-101124BP	SFR w/unfinished basement - 1994 UBC		1998
New	Approved Basic #97-108775BP	Plan #1716 S	Split Level SFR - 1994 UBC	1998
New	Approved Basic #96-100373BP	SFR w/unfinished basement - 1994 UBC		1998
New	Approved Basic #97-105611BP	Plan #1632	Two Story SFR - 1994 UBC	1998
New	Approved Basic #96-100373BP	SFR w/unfinished basement - 1994 UBC		1998
New	Approved Basic #96-101124BP	SFR w/unfinished basement - 1994 UBC		1998
New	Approved Basic #96-100373BP	SFR w/unfinished basement - 1994 UBC		1998
New	Approved Basic #96-100816BP	SFR w/finished basement - 1994 UBC		1998
New	Approved Basic #96-101124BP	SFR w/unfinished basement - 1994 UBC		1998
New	Approved Basic #97-105611BP	Plan #1632	Two Story SFR - 1994 UBC	1998
New	Approved Basic #96-100373BP	SFR w/unfinished basement - 1994 UBC		1998
New	Approved Basic #96-101119BP	Ramble Style SFR - 1994 UBC		1998
New	Approved Basic #96-101119BP	Ramble Style SFR - 1994 UBC		1998
New	Approved Basic #96-105640BP	SFR w/finished lower floor - 1994 UBC		1998
New	Approved Basic #96-110241BP	Plan 1452	Rambler Style SFR - 1994 UBC	1998
New	Approved Basic #96-110241BP	Plan 1452	Rambler Style SFR - 1994 UBC	1998
New	Approved Basic #96-100373BP	SFR w/unfinished basement - 1994 UBC		1998
New	Approved Basic #96-105640BP	SFR w/finished lower floor - 1994 UBC		1998
New	Approved Basic #96-100373BP	SFR w/unfinished basement - 1994 UBC		1998
New	Approved Basic #96-100816BP	SFR w/finished basement - 1994 UBC		1998
New	Approved Basic #96-110241BP	Plan 1452	Rambler Style SFR - 1994 UBC	1998
New	Approved Basic #96-101124BP	SFR w/unfinished basement - 1994 UBC		1998
New	Approved Basic #96-101124BP	SFR w/unfinished basement - 1994 UBC		1998
New	Approved Basic #96-100816BP	SFR w/finished basement - 1994 UBC		1998
New	Approved Basic #96-101124BP	SFR w/unfinished basement - 1994 UBC		1998
New	Approved Basic #96-100373BP	SFR w/unfinished basement - 1994 UBC		1998
New	Approved Basic #97-105611BP	Plan #1632	Two Story SFR - 1994 UBC	1998
New	Approved Basic #96-100373BP	SFR w/unfinished basement - 1994 UBC		1998

Accessory Dwelling Units

Index # - File Name: 1.0022 - Single Family Dwellings Data\_Snohomish County.pdf

New	Approved Basic #96-105640BP	SFR w/finished lower floor - 1994 UBC	1998
New	Approved Basic #97-108775BP	Plan #1716 S Split Level SFR - 1994 UBC	1998
New	Approved Basic #96-100373BP	SFR w/unfinished basement - 1994 UBC	1998
New	Approved Basic #96-100373BP	SFR w/unfinished basement - 1994 UBC	1998
New	Approved Basic #96-110241BP	Plan 1452 Rambler Style SFR - 1994 UBC	1998
New	Approved Basic #96-101124BP	SFR w/unfinished basement - 1994 UBC	1998
New	Approved Basic #96-100373BP	SFR w/unfinished basement - 1994 UBC	1998
New	Approved Basic #97-108775BP	Plan #1716 S Split Level SFR - 1994 UBC	1998
New	Approved Basic #96-101124BP	SFR w/unfinished basement - 1994 UBC	1998
New	Approved Basic #96-101124BP	SFR w/unfinished basement - 1994 UBC	1998
New	Approved Basic #96-100816BP	SFR w/finished basement - 1994 UBC	1998
New	Approved Basic #96-110241BP	Plan 1452 Rambler Style SFR - 1994 UBC	1998
New	Approved Basic #96-105640BP	SFR w/finished lower floor - 1994 UBC	1998
New	SFR w/unfinished basement - 1994 UBC	Plan #2206	1998
New	Approved Basic #97-105611BP	Plan #1632 Two Story SFR - 1994 UBC	1998
New	Approved Basic #96-105640BP	SFR w/finished lower floor - 1994 UBC	1998
New	Approved Basic #97-105611BP	Plan #1632 Two Story SFR - 1994 UBC	1998
New	Approved Basic #96-100373BP	SFR w/unfinished basement - 1994 UBC	1998
New	Approved Basic #96-100816BP	SFR w/finished basement - 1994 UBC	1998
New	Approved Basic #96-100373BP	SFR w/unfinished basement - 1994 UBC	1998
New	Approved Basic #96-101124BP	SFR w/unfinished basement - 1994 UBC	1998
New	Approved Basic #96-110241BP	Plan 1452 Rambler Style SFR - 1994 UBC	1998
New	Approved Basic #97-105611BP	Plan #1632 Two Story SFR - 1994 UBC	1998
New	Approved Basic #97-108775BP	Plan #1716 S Split Level SFR - 1994 UBC	1998
New	Approved Basic #96-100373BP	SFR w/unfinished basement - 1994 UBC	1998
New	Approved Basic 98-102356-BP	Plan 11286 One story SFR w/	1998
New	1997 Redman Wynnewood 28 x 44		1998
New	Approved Basic #98-102616BP	Plan #1438 SFR w/finished b	1998
New	Approved Basic Plan #98-102276-BP	Two Story SFR - 1994 - UBC	1998
New	Approved Basic 98-102055BP	Plan #1621 2 Story w/2 Car	1998
New	Approved Basic Plan #98-102276-BP	Two Story SFR - 1994 - UBC	1998
New	Approved Basic #98-102616BP	Plan #1438 SFR w/finished b	1998
New	Approved Basic 98-102055BP	Plan #1621 2 Story w/2 Car	1998
New	Approved Basic Plan #98-102276-BP	Two Story SFR - 1994 - UBC	1998
New	Approved Basic Plan #98-102276BP	Plan #1533 Two Story SFR - 1994 - UBC	1998
New	Approved Basic 98-102055BP	Plan #1621 2 Story w/2 Car	1998
New	Approved Basic Plan #98-102276BP	Plan #1533 Two Story SFR - 1994 - UBC	1998
New	Approved Basic 98-102055BP	Plan #1621 2 Story w/2 Car	1998
New	Approved Basic Plan #98-102276BP	Plan #1533 Two Story SFR - 1994 - UBC	1998
New	Approved Basic 98-102055BP	Plan #1621 2 Story w/2 Car	1998
New	Approved Basic Plan #98-102276BP	Plan #1533 Two Story SFR - 1994 - UBC	1998
New	Approved Basic Plan #98-102276BP	Plan #1533 Two Story SFR - 1994 - UBC	1998
New	Approved Basic #98-102616BP	Plan #1438 SFR w/finished b	1998
New	Approved Basic 98-102055BP	Plan #1621 2 Story w/2 Car	1998
New	Approved Basic Plan #98-102276BP	Plan #1533 Two Story SFR - 1994 - UBC	1998
New	Approved Basic Plan #98-102276BP	Plan #1533 Two Story SFR - 1994 - UBC	1998
New	Approved Basic 98-102055BP	Plan #1621 2 Story w/2 Car	1998

Accessory Dwelling Units

Index # - File Name: 1.0022 - Single Family Dwellings Data\_Snohomish County.pdf

New	Approved Basic Plan #98-102276BP	Plan #1533	Two Story SFR - 1994 - UBC	1998
New	Approved Basic #98-102616BP	Plan #1438	SFR w/finished b	1998
New	Approved Basic 98-102055BP	2 Story w/2 Car		1998
New	Approved Basic #98-102616BP	Plan #1438	SFR w/finished b	1998
New	Two Story SFR - 1994 UBC			1998
New	Two Story SFR - 1994 UBC			1998
New	2 story sfr with 2 car garage -			1998
New	1998 27 x 56 Palm Harbor			1998
New	Two-story SFR w/unfin basement & attached garage			1998
New	One-story SFR w/attached garage			1998
New	Duplex w/ attached garage			1998
New	Daylight Basement style SFR w/attached garage.			1998
New	2202 sf rambler w/576 sf garage			1998
New	Two-story SFR w/attached garage			1998
New	Two Story SFR with Unfinished Basement			1998
New	2537 sf rambler w/925 sf garage			1998
New	Two-story SFR w/attached garage			1998
New	Approved Basic #97-111733BP	Plan #5211/5311	Two Story SFR - 1994 UBC	1998
New	Approved Basic #97-109187BP	Plan 5018/5118	Two Story SFR - 1994 UBC	1998
New	Approved Basic #97-111735BP	Plan: 5016/5116	Two Story SFR - 1994 UBC	1998
New	Approved Basic #97-111375 BP	Plan #5019/5119	Two Story SFR - 1994 UBC	1998
New	Approved Basic #97-111375 BP	Plan #5019/5119	Two Story SFR - 1994 UBC	1998
New	Approved Basic #98-100878BP	Plan: 5214/5314	Two Story SFR - 1994 UBC \	1998
New	Approved Basic #97-109187BP	Plan 5018/5118	Two Story SFR - 1994 UBC	1998
New	Approved Basic #98-100878BP	Plan: 5214/5314	Two Story SFR - 1994 UBC \	1998
New	Two Story SFR - 1994 UBC	Plan #5211/5311		1998
New	Approved Basic #97-109187BP	Plan 5018/5118	Two Story SFR - 1994 UBC	1998
New	Approved Basic #97-111733BP	Plan #5211/5311	Two Story SFR - 1994 UBC	1998
New	Two Story SFR - 1997 UBC	Plan #5018,5118		1998
New	Approved Basic #97-111375 BP	Plan #5019/5119	Two Story SFR - 1994 UBC	1998
New	Approved Basic #97-109187BP	Plan 5018/5118	Two Story SFR - 1994 UBC	1998
New	Approved Basic #98-100878BP	Plan: 5214/5314	Two Story SFR - 1994 UBC \	1998
New	Approved Basic #97-109187BP	Plan 5018/5118	Two Story SFR - 1994 UBC	1998
New	Approved Basic #97-111733BP	Plan #5211/5311	Two Story SFR - 1994 UBC	1998
New	Approved Basic #97-109187BP	Plan 5018/5118	Two Story SFR - 1994 UBC	1998
New	Two Story SFR - 1997 UBC	Plan #5016,5116		1998
New	Approved Basic #98-107691BP	(4 Bedrooms)	Two Story SFR - 19	1998
New	Approved Basic #98-107686BP	(4 Bedrooms)	Two Story SFR - 19	1998
New	Approved Basic #98-107691BP	(4 Bedrooms)	Two Story SFR - 19	1998
New	Approved Basic #98-107685BP	(4 Bedrooms)	Two Story SFR - 19	1998
New	Approved Basic #98-107689BP	(4 Bedrooms)	Two Story SFR - 19	1998
New	Approved Basic #98-107685BP	(4 Bedrooms)	Two Story SFR - 19	1998
New	Approved Basic #98-107691BP	(4 Bedrooms)	Two Story SFR - 19	1998
New	Approved Basic #98-107689BP	(4 Bedrooms)	Two Story SFR - 19	1998
New	Approved Basic #98-107691BP	(4 Bedrooms)	Two Story SFR - 19	1998
New	Approved Basic #98-107692BP	(4 Bedrooms)	Two Story SFR - 19	1998
New	Approved Basic #98-107691BP	(4 Bedrooms)	Two Story SFR - 19	1998

Accessory Dwelling Units

Index # - File Name: 1.0022 - Single Family Dwellings Data\_Snohomish County.pdf

New	Approved Basic #98-107685BP	(4 Bedrooms) Two Story SFR - 1997 UBC	1998
New	Two Story SFR - 1997 UBC	Plan: #5027	1998
New	Approved Basic #98-107692BP	(4 Bedrooms) Two Story SFR - 1997 UBC	1998
New	Approved Basic #98-107686BP	(4 Bedrooms) Two Story SFR - 1997 UBC	1998
New	Two Story SFR - 1997 UBC	Plan #5019/5119	1998
New	Approved Basic #98-107691BP	(4 Bedrooms) Two Story SFR - 1997 UBC	1998
New	Two Story SFR - 1997 UBC	Plan #5211/5311	1998
New	Approved Basic #97-111732BP	Plan: #5017/5117 Two Story SFR - 1994 UBC	1998
New	Approved Basic #97-109187BP	Plan 5018/5118 Two Story SFR - 1994 UBC	1998
New	Approved Basic #97-111375 BP	Plan #5019/5119 Two Story SFR - 1994 UBC	1998
New	Approved Basic #97-111735BP	Plan: 5016/5116 Two Story SFR - 1994 UBC	1998
New	Approved Basic #97-111733BP	Plan #5211/5311 Two Story SFR - 1994 UBC	1998
New	Approved Basic #97-109187BP	Plan 5018/5118 Two Story SFR - 1994 UBC	1998
New	Approved Basic #97-109187BP	Plan 5018/5118 Two Story SFR - 1994 UBC	1998
New	Approved Basic #97-111733BP	Plan #5211/5311 Two Story SFR - 1994 UBC	1998
New	Approved Basic #97-109187BP	Plan 5018/5118 Two Story SFR - 1994 UBC	1998
New	Approved Basic #97-111375 BP	Plan #5019/5119 Two Story SFR - 1994 UBC	1998
New	Two Story SFR - 1994 UBC	Plan #5016/5116	1998
New	Approved Basic #97-111733BP	Plan #5211/5311 Two Story SFR - 1994 UBC	1998
New	Two Story SFR- 1994 UBC	Plan #5017/5117	1998
New	2 Story w/1 car		1998
New	2250 s.f. rambler		1998
New	2 story sfr with 3 car garage		1998
New	Two Story SFR - 1994 UBC	Plan #2723	1998
New	Rambler Style SFR - 1994 UBC	Plan #2672	1998
New	Two Story SFR - 1994 UBC	Plan #3012	1998
New	Two Story SFR - 1994 UBC	Plan #2792	1998
New	Two Story SFR - 1994 UBC	Plan #2720	1998
New	Two Story SFR - 1994 UBC	Plan #2804	1998
New	Two Story SFR - 1994 UBC	Plan: 2873	1998
New	Two Story SFR - 1994 UBC	Plan #3480	1998
New	Rambler Style SFR - 1994 UBC	Plan #2700	1998
New	One-story SFR w/attached garage		1998
New	Approved Basic #95-108142BP	Plan 2195-2 SFR w/finished basement - 1994	1998
New	1990 28 x 66 Fleetwood		1998
New	2 story duplex with attached garage		1998
New	1168 sf rambler w/451 sf garage and 111 sf covered deck/porch		1998
New	Two Story SFR with Basement and Attached Garage		1998
New	Rambler w/ 2 car		1998
New	Approved Basic #96-101074BP	Two Story Duplex - 1994 UBC	1998
New	Approved Basic #95-109179BP	Plan 1705 2 story sfr w/finished Basement-	1998
New	Approved Basic #96-109445BP	Plan #1715 Two Story SFR - 1994 UBC	1998
New	Approved Basic #96-100375BP	Plan #1502 Rambler Style SFR - 1994 UBC	1998
New	Approved Basic #96-109445BP	Plan #1715 Two Story SFR - 1994 UBC	1998
New	Approved Basic #95-109179BP	Plan 1705 2 story sfr w/finished Basement-	1998
New	Approved Basic #96-100375BP	Plan #1502 Rambler Style SFR - 1994 UBC	1998
New	2 Story SFR with attached garage - 1994 UBC		1998

Accessory Dwelling Units

Index # - File Name: 1.0022 - Single Family Dwellings Data\_Snohomish County.pdf

New	42x66 (1997) Lamplighter		1998
New	Rambler style SFR with attached garage		1998
New	2 story duplex		1998
New	SFR w/unfinished basement - 1997 UBC		1998
New	Approved Basic #96-105824BP	Rambler Style SFR - 1994 UBC	1998
New	1994 UBC - 2607 sf 2-story w/690 sf garage and 128 sf covered porch		1998
New	28x48, 1998 Woodbridge		1998
New	1997 27 x 42 Palm Harbor		1998
New	2-Story SFR with attached garage - 1994 UBC		1998
New	Two Story SFR with Attached Garage		1998
New	Two-story SFR w/attached garage		1998
New	Rambler w/ 3 Car		1998
New	2113 sf 2-story w/788 sf finished basement and 700 sf garage		1998
New	2 Story w/ 3Car		1998
New	2 Story w/ 3Car		1998
New	Approved Basic #98-101443BP	Two story sfr with 2car/3car garage	1998
New	2-Story SFR w/attached Garage		1998
New	Rambler Style SFR - 1994 UBC	Plan #1420	1998
New	Rambler with attached carport - 1997 UBC		1998
New	Application filed under Michael Hansen, Ref. 98-100962 AB	SFR w/finished basement - 1994 UI	1998
New	Approved Basic #97-107566BP	Rambler Style Duplex - 1994 UBC	1998
New	Approved Basic #97-107566BP	Rambler Style Duplex - 1994 UBC	1998
New	Two Story SFR with Attached Garage		1998
New	Approved Basic #97-102037 BP	Plan #212-3 SFR w/finished basement - 1994 U	1998
New	Approved Basic #97-102037 BP	Plan #212-3 SFR w/finished basement - 1994 U	1998
New	SFR with daylighted basement and garage - 1994 UBC		1998
New	2 story SFR with attached garage		1998
New	Approved Basic #98-102461BP	Plan #472-2-3 Two Story SFR - 1994	1998
New	Approved Basic #98-102340 BP	Plan #473-2-3 Two Story SFR - 1994 UBC	1998
New	Approved Basic #98-102458BP	Plan #471-3 Two Story SFR - 1994	1998
New	Approved Basic #96-103849BP	Two Story SFR -1994 UBC	1998
New	2322 sf 2-story w/528 sf garage and 13 sf covered porch		1998
New	2176 sf 2-story w/528 sf garage and 14 sf covered porch		1998
New	Approved Basic #97-102037 BP	Plan #212-3 SFR w/finished basement - 1994 U	1998
New	Rambler with attached garage and daylighted - 1994 UBC		1998
New	2 story sfr with 2 car garage		1998
New	1998 27 x 44 Fleetwood		1998
New	(27 x 56) Palm Harbor #1057		1998
New	Rambler with attached garage - 1994 UBC		1998
New	Two-story SFR		1998
New	Split Entry style SFR w/garage.		1998
New	Two-story SFR w/attached garage		1998
New	Approved Basic. #98-101137-BP	2-Story SFR w/attached garage. Bldrs. plan #2	1998
New	Approved Basic # 98-101907 BP	Plan 2704 Two story SFR w/	1998
New	2 story sfr with attached garage		1998
New	2 story sfr with attached garage		1998
New	1652 sf rambler w/772 sf finished basement and 714 sf garage and 24 sf covered porch		1998

Accessory Dwelling Units

Index # - File Name: 1.0022 - Single Family Dwellings Data\_Snohomish County.pdf

New	Rambler Style SFR - 1994 UBC			1998
New	Approved Basic #96-101863BP	Plan 1927-3	Two Story SFR - 1994 UBC	OP 1998
New	Rambler style SFR w/attached garage			1998
New	28 x 48 - 1998 Baycrest			1998
New	Approved Basic #96-104699BP	Rambler Style SFR - 1994 UBC		1998
New	2 Story w/ 4 Car			1998
New	One-story SFR w/attached garage			1998
New	39x67 (1998) Silvercrest			1998
New	2-Story SFR w/attached garage			1998
New	Approved Basic 98-101094-BP	Plan 2415	Two-story SFR w	1998
New	Approved Basic # 98-101907 BP	Plan 2704	Two story SFR w/	1998
New	Approved Basic #98-101137BP	2-Story SFR w/attached garage.	Bldrs. plan #21	1998
New	1979 28 x 70 Silver Crest			1998
New	1998 Champion 28 x 50			1998
New	2844 sf 2-story with 682 sf garage and 64 sf covered deck/porch			1998
New	Approved Basic #97-111047BP	THIS BASIC IS NOT APPROVED FOR 25 BUILDING HEIGHT ZON		1998
New	Two-story SFR w/attached garage			1998
New	Approved Basic #97-111572BP	Plan #7003	Two Story SFR - 1994 UBC	1998
New	Approved Basic #97-111572BP	Plan #7003	Two Story SFR - 1994 UBC	1998
New	Approved Basic #97-111572BP	Plan #7003	Two Story SFR - 1994 UBC	1998
New	Approved Basic #97-111571BP	Plan #7002	Two Story SFR - 1994 UBC	1998
New	Approved Basic #97-111572BP	Plan #7003	Two Story SFR - 1994 UBC	1998
New	Approved Basic #97-111571BP	Plan #7002	Two Story SFR - 1994 UBC	1998
New	Approved Basic #97-111572BP	Plan #7003	Two Story SFR - 1994 UBC	1998
New	Approved Basic #97-111571BP	Plan #7002	Two Story SFR - 1994 UBC	1998
New	Approved Basic #97-111572BP	Plan #7003	Two Story SFR - 1994 UBC	1998
New	Approved Basic #97-111571BP	Plan #7002	Two Story SFR - 1994 UBC	1998
New	Approved Basic #97-111572BP	Plan #7003	Two Story SFR - 1994 UBC	1998
New	Approved Basic #97-111571BP	Plan #7002	Two Story SFR - 1994 UBC	1998
New	Approved Basic #97-111572BP	Plan #7003	Two Story SFR - 1994 UBC	1998
New	Approved Basic #97-111571BP	Plan #7002	Two Story SFR - 1994 UBC	1998
New	Approved Basic #97-111572BP	Plan #7003	Two Story SFR - 1994 UBC	1998
New	Approved Basic #97-111569BP	Plan #7001	Two Story SFR - 1994 UBC	1998
New	Approved Basic #97-111572BP	Plan #7003	Two Story SFR - 1994 UBC	1998
New	Approved Basic #97-111572BP	Plan #7003	Two Story SFR - 1994 UBC	1998
New	Approved Basic #97-111571BP	Plan #7002	Two Story SFR - 1994 UBC	1998
New	Approved Basic #97-111571BP	Plan #7002	Two Story SFR - 1994 UBC	1998
New	Approved Basic #97-111571BP	Plan #7002	Two Story SFR - 1994 UBC	1998
New	Approved Basic #97-111572BP	Plan #7003	Two Story SFR - 1994 UBC	1998
New	Approved Basic #97-111571BP	Plan #7002	Two Story SFR - 1994 UBC	1998
New	Approved Basic #97-111572BP	Plan #7003	Two Story SFR - 1994 UBC	1998
New	2-Story SFR with attached garage			1998
New	2 story w/3 car			1998
New	2 Story w/Bsmt & 3 Car			1998
New	2 Story SFR with attached garage - 1994 UBC			1998

Accessory Dwelling Units

Index # - File Name: 1.0022 - Single Family Dwellings Data\_Snohomish County.pdf

New	Split Entry Style SFR w/attached garage		1998
New	2-Story SFR w/attached garage		1998
New	1998 28 x 66 Golden West		1998
New	64 X 61 Single Story Duplex w/attached garage		1998
New	Builders Plan - #1333 - 2 story with Duplex with attached garage - 1994 UBC.		1998
New	Builders No. 1256 - 2 story with Duplex with attached garage - 1994 UBC.		1998
New	2 Story w/ 2 Car		1998
New	Approved Basic #95-109111BP	Plan #1876 Two Story SFR - 1994 UBC	1998
New	Approved Basic #98-107735	Plan # Aspen Two Story SFR - 1997 UBC	1998
New	Approved Basic #98-107735	Plan # Aspen Two Story SFR - 1997 UBC	1998
New	2148 sf 2-story w/508 sf garage and 36 sf covered deck/porch		1998
New	Two Story SFR - 1994 UBC	Plan #7750	1998
New	2-Story SFR w/attached garage.		1998
New	Two Story SFR - 1994 UBC	Plan #2965	1998
New	2-Story SFR w/attached garage.		1998
New	2-Story SFR w/attached garage.		1998
New	Two Story SFR - 1994 UBC	Plan 2650	1998
New	2034 sf rambler w/1994 sf finished daylight basement		1998
New	2-Story SFR w/attached garage & covered porches.		1998
New	2 story SFR with attached garage		1998
New	2 Story SFR with attached garage - 1994 UBC		1998
New	Daylight basement style SFR w/basement garage/shop.		1998
New	1296 s.f. rambler with 2 car garage		1998
New	Approved Basic #98-106423BP Two Story SFR - 1994 UBC	Plan #7	1998
New	Two Story SFR with attached Garage		1998
New	Two Story SFR with Attached Garage		1998
New	Approved Basic #98-106423BP	Plan #7836 Two Story SFR - 1994 UBC	1998
New	Two Story SFR - 1994 UBC	Plan: Walton	1998
New	Approved Basic #98-104134BP	Plan: #2650 Two Story SFR - 1994 UBC	1998
New	Two Story SFR - 1994 UBC	Plan #2965	1998
New	Two Story SFR - 1994 UBC	Plan #2965	1998
New	Approved Basic #95-108472BP	Plan 1446 Rambler Style SFR - 1994 UBC	1998
New	Approved Basic #95-109256BP	Plan #1520 Rambler Style SFR - 1994 UBC	1998
New	Approved Basic #95-108472BP	Plan 1446 Rambler Style SFR - 1994 UBC	1998
New	Approved Basic #95-108472BP	Plan 1446 Rambler Style SFR - 1994 UBC	1998
New	Approved Basic #95-108472BP	Plan 1446 Rambler Style SFR - 1994 UBC	1998
New	Approved Basic #95-109256BP	Plan #1520 Rambler Style SFR - 1994 UBC	1998
New	Approved Basic #95-108472BP	Plan 1446 Rambler Style SFR - 1994 UBC	1998
New	Approved Basic #95-108472BP	Plan 1446 Rambler Style SFR - 1994 UBC	1998
New	Approved Basic #95-108472BP	Plan 1446 Rambler Style SFR - 1994 UBC	1998
New	2 story SFR w/ attached garage		1998
New	Approved Basic #95-109256BP	Plan #1520 Rambler Style SFR - 1994 UBC	1998
New	Approved Basic #95-108472BP	Plan 1446 Rambler Style SFR - 1994 UBC	1998
New	Approved Basic #95-108472BP	Plan 1446 Rambler Style SFR - 1994 UBC	1998
New	Approved Basic #95-108472BP	Plan 1446 Rambler Style SFR - 1994 UBC	1998
New	Approved Basic #95-109256BP	Plan #1520 Rambler Style SFR - 1994 UBC	1998
New	Approved Basic #95-108472BP	Plan 1446 Rambler Style SFR - 1994 UBC	1998

Accessory Dwelling Units

Index # - File Name: 1.0022 - Single Family Dwellings Data\_Snohomish County.pdf

New	Approved Basic #95-108472BP	Plan 1446	Rambler Style SFR - 1994 UBC	1998
New	Approved Basic #95-108472BP		Plan 1446 Rambler Style SFR - 1994	1998
New	Approved Basic #95-109256BP	Plan #1520	Rambler Style SFR - 1994 UBC	1998
New	Approved Basic #95-108472BP	Plan 1446	Rambler Style SFR - 1994 UBC	1998
New	Approved Basic #95-108472BP	Plan 1446	Rambler Style SFR - 1994 UBC	1998
New	Approved Basic #95-109256BP	Plan #1520	Rambler Style SFR - 1994 UBC	1998
New	1290-sf rambler w/417-sf garage and 40-sf covered porch.			1998
New	Approved Basic #95-109256BP	Plan #1520	Rambler Style SFR - 1994 UBC	1998
New	Approved Basic #95-108472BP	Plan 1446	Rambler Style SFR - 1994 UBC	1998
New	Approved Basic #95-108472BP	Plan 1446	Rambler Style SFR - 1994 UBC	1998
New	1296 s.f. rambler with 2 car garage			1998
New	Approved Basic #97-103628BP	Plan #1581	Rambler Style SFR - 1994 UBC	1998
New	Rambler w/ 2 car			1998
New	Approved Basic #98-100392BP	Plan #1214	1214 sf rambler w/ 483 sf ga	1998
New	Approved Basic #98-100392BP	Plan #1214	1214 sf rambler w/ 483 sf ga	1998
New	Approved Basic #98-100392BP	Plan #1214	1214 sf rambler w/ 483 sf ga	1998
New	Approved Basic #98-100392BP	Plan #1214	1214 sf rambler w/ 483 sf ga	1998
New	Approved Basic #98-100392BP	Plan #1214	1214 sf rambler w/ 483 sf ga	1998
New	Approved Basic #97-103628BP	Plan #1581	Rambler Style SFR - 1994 UBC	1998
New	Approved Basic #97-103628BP	Plan #1581	Rambler Style SFR - 1994 UBC	1998
New	Approved Basic #98-100392BP	Plan #1214	1214 sf rambler w/ 483 sf ga	1998
New	Approved Basic #98-100392BP	Plan #1214	1214 sf rambler w/ 483 sf ga	1998
New	Approved Basic #97-103628BP	Plan #1581	Rambler Style SFR - 1994 UBC	1998
New	Approved Basic #98-100392BP	Plan #1214	1214 sf rambler w/483 sf gar	1998
New	Approved Basic #95-108472BP	Plan 1446	Rambler Style SFR - 1994 UBC	1998
New	Approved Basic #95-109256BP	Plan #1520	Rambler Style SFR - 1994 UBC	1998
New	Approved Basic #95-108472BP	Plan 1446	Rambler Style SFR - 1994 UBC	1998
New	Approved Basic #95-108472BP	Plan 1446	Rambler Style SFR - 1994 UBC	1998
New	Approved Basic #95-109256BP	Plan #1520	Rambler Style SFR - 1994 UBC	1998
New	Approved Basic #98-105951BP	Plan #1504	Two Story SFR - 1	1998
New	Approved Basic #98-105948BP	Plan #1290	Two Story SFR - 1997	1998
New	Approved Basic #98-105948BP	Plan #1290	Two Story SFR - 1997	1998
New	Approved Basic #98-105945BP	Plan #1008	Rambler Style SFR - 1994	1998
New	Approved Basic #98-105945BP	Plan #1008	Rambler Style SFR - 1994	1998
New	Approved Basic #98-105945BP	Plan #1008	Rambler Style SFR - 1994	1998
New	Approved Basic #98-105951BP	Plan #1504	Two Story SFR - 1	1998
New	Approved Basic #98-105945BP	Plan #1008	Rambler Style SFR - 1994	1998
New	Approved Basic #98-105945BP	Plan #1008	Rambler Style SFR - 1994	1998
New	Approved Basic #98-105951BP	Plan #1504	Two Story SFR - 1	1998
New	Approved Basic #98-105948BP	Plan #1290	Two Story SFR - 1997	1998
New	Two Story SFR - 1997 UBC		Plan #1504	1998
New	Rambler Style SFR - 1994 UBC		Plan #1008	1998
New	Two Story SFR - 1997 UBC		Plan #1290	1998
New	Two Story SFR - 1997 UBC		Plan #1290	1998
New	Rambler Style SFR - 1994 UBC		Plan #1008	1998
New	Two Story SFR - 1997 UBC		Plan #1290	1998
New	Rambler Style SFR - 1994 UBC		Plan #1008	1998



Accessory Dwelling Units

Index # - File Name: 1.0022 - Single Family Dwellings Data\_Snohomish County.pdf

New	Rambler Style SFR - 1994 UBC	Plan #1008	1998
New	Rambler Style SFR - 1994 UBC	Plan #1008	1998
New	Rambler Style SFR - 1994 UBC	Plan #1008	1998
New	Rambler Style SFR - 1994 UBC	Plan #1008	1998
New	Rambler Style SFR - 1994 UBC	Plan #1008	1998
New	Rambler Style SFR - 1994 UBC	Plan #1008	1998
New	Two Story SFR - 1997 UBC	Plan #1504	1998
New	Two Story SFR - 1997 UBC	Plan #1290	1998
New	Two Story SFR - 1997UBC	Plan #1504	1998
New	Two Story SFR - 1997 UBC	Plan #1290	1998
New	Approved Basic #98-105945BP	Plan #1008 Rambler Style SFR - 1994 UBC	1998
New	Approved Basic #98-105951BP	Plan #1504 Two Story SFR - 1997 UBC	1998
New	Approved Basic #98-105945BP	Plan #1008 Rambler Style SFR - 1994 UBC	1998
New	Rambler Style SFR - 1994 UBC	Plan #1008	1998
New	Approved Basic #98-105948BP	Plan #1290 Two Story SFR - 1997 UBC	1998
New	Approved Basic #98-105945BP	Plan #1008 Rambler Style SFR - 1994 UBC	1998
New	Approved Basic #98-105945BP	Plan #1008 Rambler Style SFR - 1994 UBC	1998
New	One-story Duplex w/attached garage		1998
New	Two-story SFR w/attached garage		1998
New	Rambler w/2 Car		1998
New	2-Story SFR w/attached garage.		1998
New	Approved Basic #97-105227BP	Plan #1024A Rambler Style SFR - 1994 UBC	1998
New	1660 sf 2-story w/475 sf garage and 62 sf covered deck/porch		1998
New	2599 sf 2-story w/816 sf garage and 168 sf covered porch		1998
New	Rambler with Attached Garage		1998
New	2201 sf rambler w/980 sf garage and 96 sf covered deck/porch		1998
New	2-Story SFR w/attached garage		1998
New	Approved Basic #96-101863BP	Plan 1927-3 Two Story SFR - 1994 UBC	OP 1998
New	Approved Basic #98-101728BP	Plan #Rebecca 1-A SFR w/finished basement	1998
New	SFR w/finished lower floor - 1994 UBC	Plan #2302	1998
New	Approved Basic #96-100583BP	Plan #1905-3 Two Story SFR - 1994 UBC	OP 1998
New	Approved Basic #95-108142BP	Plan 2195-2 SFR w/finished basement - 1994	1998
New	Approved Basic #96-105566BP	Plan #2084-3 Two Story SFR - 1994 UBC	1998
New	Approved Basic #95-108142BP	Plan 2195-2 SFR w/finished basement - 1994	1998
New	Approved Basic #96-105566BP	Plan #2084-3 Two Story SFR - 1994 UBC	1998
New	Approved Basic #98-103827BP	Plan #23020 SFR w/finished basement - 1994	1998
New	Approved Basic #96-100583BP	Plan #1905-3 Two Story SFR - 1994 UBC	OP 1998
New	Approved Basic #95-108142BP	Plan 2195-2 SFR w/finished basement - 1994	1998
New	Approved Basic #96-100583BP	Plan #1905-3 Two Story SFR - 1994 UBC	OP 1998
New	Approved Basic #97-107334BP	Split Level SFR w/unfinished lower floor - 1994 UBC	1998
New	1998 Golden West Villa West 40 x 60		1998
New	Approved Basic #97-104822BP	Plan #1775 Two Story SFR - 1994 UBC	1998
New	Approved Basic #97-104831BP	Plan 1639 Two Story SFR - 1994 UBC	1998
New	Approved Basic #97-104556BP	Plan #1389 Two Story SFR - 1994 UBC	1998
New	Approved Basic #97-104831BP	Plan 1639 Two Story SFR - 1994 UBC	1998
New	Approved Basic #97-104829BP	Plan #1661 Two Story SFR - 1994 UBC	1998
New	Approved Basic #97-104831BP	Plan 1639 Two Story SFR - 1994 UBC	1998

Accessory Dwelling Units

Index # - File Name: 1.0022 - Single Family Dwellings Data\_Snohomish County.pdf

New	Approved Basic #97-111003BP	Plan #2018 Two Story SFR - 1994 UBC	1998
New	Approved Basic #97-104829BP	Plan #1661 Two Story SFR - 1994 UBC	1998
New	Approved Basic #97-101584BP	Plan #1895 Two Story SFR - 1994 UBC	1998
New	Approved Basic #97-104556BP	Plan #1389 Two Story SFR - 1994 UBC	1998
New	Approved Basic #97-104831BP	Plan 1639 Two Story SFR - 1994 UBC	1998
New	Approved Basic #97-104556BP	Plan #1389 Two Story SFR - 1994 UBC	1998
New	Approved Basic #97-104831BP	Plan 1639 Two Story SFR - 1994 UBC	1998
New	Approved Basic #97-104822BP	Plan #1775 Two Story SFR - 1994 UBC	1998
New	Approved Basic #97-104831BP	Plan 1639 Two Story SFR - 1994 UBC	1998
New	Approved Basic #97-104556BP	Plan #1389 Two Story SFR - 1994 UBC	1998
New	Approved Basic #97-104831BP	Plan 1639 Two Story SFR - 1994 UBC	1998
New	Approved Basic #97-104831BP	Plan 1639 Two Story SFR - 1994 UBC	1998
New	Approved Basic #97-104556BP	Plan #1389 Two Story SFR - 1994 UBC	1998
New	Approved Basic #97-104831BP	Plan 1639 Two Story SFR - 1994 UBC	1998
New	Approved Basic #97-111003BP	Plan #2018 Two Story SFR - 1994 UBC	1998
New	Approved Basic #97-106548BP	Plan #2143 Two Story SFR - 1994 UBC	1998
New	Approved Basic #97-104556BP	Plan #1389 Two Story SFR - 1994 UBC	1998
New	Approved Basic #96-102270BP	Plan #2054 Two Story SFR - 1994 UBC	1998
New	Approved Basic #97-104831BP	Plan 1639 Two Story SFR - 1994 UBC	1998
New	Approved Basic #97-104829BP	Plan #1661 Two Story SFR - 1994 UBC	1998
New	Approved Basic #97-104822BP	Plan #1775 Two Story SFR - 1994 UBC	1998
New	Approved Basic #96-102270BP	Plan #2054 Two Story SFR - 1994 UBC	1998
New	Approved Basic #97-101584BP	Plan #1895 Two Story SFR - 1994 UBC	1998
New	Approved Basic #96-102270BP	Plan #2054 Two Story SFR - 1994 UBC	1998
New	Approved Basic #97-104831BP	Plan 1639 Two Story SFR - 1994 UBC	1998
New	Approved Basic #97-111003BP	Plan #2018 Two Story SFR - 1994 UBC	1998
New	Approved Basic #97-101584BP	Plan #1895 Two Story SFR - 1994 UBC	1998
New	Approved Basic #97-104822BP	Plan #1775 Two Story SFR - 1994 UBC	1998
New	Approved Basic #97-104556BP	Plan #1389 Two Story SFR - 1994 UBC	1998
New	Approved Basic #97-104831BP	Plan 1639 Two Story SFR - 1994 UBC	1998
New	2 story SFR with attached garage and covered porch		1998
New	1660 sf main floor w/1591 sf finished basement, 484 sf garage and 47 sf covered deck/porch		1998
New	Two-story SFR w/unfin basement & attached garage		1998
New	Rambler style SFR w/attached garage.		1998
New	2072 sf 2-story w/1360 sf unfinished basement and 696 sf garage and 20 sf covered porch		1998
New	One-story SFR w/attached garage		1998
New	2- Story SFR with attached garage - 1994 UBC		1998
New	14 x 66 - 1990 - Marlett		1998
New	Approved Basic #97-103863BP	Plan #1820 Rambler Style SFR - 1994 UBC	1998
New	Approved Basic #97-103863BP	Plan #1820 Rambler Style SFR - 1994 UBC	1998
New	Approved Basic #97-103866BP	Plan #1722 Rambler Style SFR - 1994 UBC	1998
New	Approved Basic #97-103866BP	Plan #1722 Rambler Style SFR - 1994 UBC	1998
New	2 story w/3 car		1998
New	Approved Basic #97-103863BP	Plan #1820 Rambler Style SFR - 1994 UBC	1998
New	Split Level SFR - 1994 UBC		1998
New	Rambler Style SFR - 1994 UBC		1998
New	Split Level SFR - 1994 UBC		1998



Accessory Dwelling Units

Index # - File Name: 1.0022 - Single Family Dwellings Data\_Snohomish County.pdf

New	28x52 (1998) #5201, #5020B #5203A		1998
New	Approved Basic #97-105464BP	Plan: Kira SFR w/unfinished lower floor	1998
New	Rambler style SFR w/attached garage		1998
New	27x64 (1998) Harbor Homes		1998
New	Split-level SFR & garage		1998
New	Approved Basic #97-100708BP	Plan #2066 Two Story SFR - 1994 UBC	1998
New	Approved Basic #98-106565BP	Plan #1340 Two Story SFR - 19	1998
New	Approved Basic #98-106561BP	Plan #1490 Two Story SFR -	1998
New	Two Story SFR - 1994 UBC		1998
New	Two Story SFR - 1994 UBC		1998
New	2 story sfr with 3 car garage.		1998
New	12x52, 1975 Sahara		1998
New	SFR w/finished basement & attached garage		1998
New	EXPIRED WITHOUT COUNTY APPROVAL TO USE OR OCCUPY DM 24 X 56 Kentwood 1973		1998
New	Approved Basic #96-103350BP Two Story SFR -1994 UBC		1998
New	1998 Oakwood 28 x 65		1998
New	1998 Skyline Amber Cove 41 x 66		1998
New	Approved Basic #97-101124BP	Plan #2211A Two Story SFR - 1994 UBC	1998
New	Approved Basic #96-110885BP	Plan 2209 C/E Two Story SFR - 1994 UBC	1998
New	Approved Basic #97-101535BP	Plan #2301 w/den Two Story SFR - 1994 UBC	1998
New	Approved Basic #97-101124BP	Plan #2211A Two Story SFR - 1994 UBC	1998
New	Approved Basic #96-110885BP	Plan 2209 C/E Two Story SFR - 1994 UBC	1998
New	Approved Basic #97-100338BP	Plan #2204 Two Story SFR - 1994 UBC	1998
New	Approved Basic #97-101124BP	Plan #2211A Two Story SFR - 1994 UBC	1998
New	Approved Basic #96-110883BP	Plan #2209 B/D Two Story SFR - 1994 UBC	1998
New	Approved Basic #96-110883BP	Plan #2209 B/D Two Story SFR - 1994 UBC	1998
New	Approved Basic #97-100338BP	Plan #2204 Two Story SFR - 1994 UBC	1998
New	Approved Basic #96-110878BP	Plan #2215 SFR w/finished basement - 1	1998
New	Two Story SFR w/finished basement - 1994 UBC	Plan #2209 C/B	1998
New	Approved Basic #97-100338BP	Plan #2204 Two Story SFR - 1994 UBC	1998
New	24 x 44 (1983) Citation		1998
New	Two Story SFR - 1994 UBC	Plan #2115	1998
New	Approved Basic #96-100375BP	Plan #1502 Rambler Style SFR - 1994 UBC	1998
New	Two Story SFR - 1994 UBC	Plan #2115	1998
New	Approved Basic #96-101277BP	Plan 1732 Two Story SFR - 1994 UBC	1998
New	Approved Basic #96-101276BP	Plan 2005 Two Story SFR - 1994 UBC	1998
New	Approved Basic #98-109993BP	Builders #1715 2-Story SFR w/attached g	1998
New	Approved Basic #96-109445BP	Plan #1715 Two Story SFR - 1994 UBC	1998
New	Approved Basic #96-101276BP	Plan 2005 Two Story SFR - 1994 UBC	1998
New	Approved Basic #98-110356BP	Plan: #2093 2093 sf 2-story w/€	1998
New	Approved Basic #98-109993BP	Builders #1715 2-Story SFR w/attached g	1998
New	Approved Basic #98-116328BP	Plan: 2190 Two Story SFR - 1997 U	1998
New	Approved Basic #96-101277BP	Plan 1732 Two Story SFR - 1994 UBC	1998
New	Approved Basic #98-110356BP	Plan #2093 Two Story SFR - 1997 UBC	1998
New	Approved Basic #96-101276BP	Plan 2005 Two Story SFR - 1994 UBC	1998
New	Convert existing TD/MH to primary residence 48x28, 1985 Berkshire		1998
New	2 story sfr with 2 car garage		1998

Accessory Dwelling Units

Index # - File Name: 1.0022 - Single Family Dwellings Data\_Snohomish County.pdf

New	Approved Basic 98-110279BP		Rambler Style SFR with attached garage --	1998
New	Rambler Style SFR - 1997 UBC		Plan # Lawson	1998
New	Approved Basic 98-110279BP		Rambler Style SFR with attached garage --	1998
New	Approved Basic #97-103626BP		Plan #1649 Two Story SFR - 1994 UBC	1998
New	Approved Basic #97-103623BP		Plan #1438 Rambler Style SFR - 1994 UBC	1998
New	Approved Basic #97-103626BP		Plan #1649 Two Story SFR - 1994 UBC	1998
New	Approved Basic #95-109256BP		Plan #1520 Rambler Style SFR - 1994 UBC	1998
New	Approved Basic #95-108472BP		Plan 1446 Rambler Style SFR - 1994 UBC	1998
New	Approved Basic #95-108472BP		Plan 1446 Rambler Style SFR - 1994 UBC	1998
New	Approved Basic #98-100392BP		Plan #1214 1214 sf ramblar w/ 483 sf ga	1998
New	Approved Basic #97-103623BP		Plan #1438 Rambler Style SFR - 1994 UBC	1998
New	Approved Basic #98-100392BP		Plan #1214 1214 sf ramblar w/ 483 sf ga	1998
New	Rambler Style SFR with attached garage -- 1997 UBC	Approved Basic 98-110279BP		1998
New	Approved Basic #95-108472BP		Plan 1446 Rambler Style SFR - 1994 UBC	1998
New	Approved Basic #95-109256BP		Plan #1520 Rambler Style SFR - 1994 UBC	1998
New	Approved Basic #95-108472BP		Plan 1446 Rambler Style SFR - 1994 UBC	1998
New	Approved Basic #95-108472BP		Plan 1446 Rambler Style SFR - 1994 UBC	1998
New	Approved Basic #95-108472BP		Plan 1446 Rambler Style SFR - 1994 UBC	1998
New	Approved Basic #95-108472BP		Plan 1446 Rambler Style SFR - 1994 UBC	1998
New	Approved Basic #95-108472BP		Plan 1446 Rambler Style SFR - 1994 UBC	1998
New	Approved Basic #95-108472BP		Plan 1446 Rambler Style SFR - 1994 UBC	1998
New	Approved Basic #95-109256BP		Plan #1520 Rambler Style SFR - 1994 UBC	1998
New	Approved Basic #95-108472BP		Plan 1446 Rambler Style SFR - 1994 UBC	1998
New	Approved Basic #95-108472BP		Plan 1446 Rambler Style SFR - 1994 UBC	1998
New	SFR w/unfinished lower floor - 1997 UBC		Plan: California Split	1998
New	2-Story SFR w/attached garage			1998
New	Approved Basic #95-110568BP	Rambler Style SFR - 1994 UBC		1998
New	Approved Basic #97-103628BP		Plan #1581 Rambler Style SFR - 1994 UBC	1998
New	Approved Basic #98-100392BP		Plan #1214 1214 sf ramblar w/ 483 sf ga	1998
New	Approved Basic #97-103628BP		Plan #1581 Rambler Style SFR - 1994 UBC	1998
New	Approved Basic #95-1105768BP	Rambler Style SFR - 1994 UBC		1998
New	Two Story SFR w/unfinished basement - 1994 UBC			1998
New	Daylight Basement SFR w/attached garage.			1998
New	Two Story SFR w/attached garage.			1998
New	2 Story w/deck. THIS PERMIT MAY BE RENEWED UNTIL 11/22/00, PER GLORIA BAKER. ***** SE			1998
New	2-Story SFR w/attached garage			1998
New	1986 Fleetwood Sandalwood 48 x 28			1998
New	2 story sfr with 4 car garage NON-OCCUPANCY NOTICE POSTED BY CHRIS GRIFFITH, 7/20/00. **			1998
New	1605 sf 2-story with 400 sf garage			1998
New	Rambler Style SFR			1998
New	Rambler style SFR w/attached garage			1998
New	Two Story SFR - 1997 UBC		Plan: 2115	1998
New	2-Story SFR w/attached garage	1997-UBC	1997-WSEC	1998
New	2-Story SFR w/attached garage		Plan: #1908/side 1997-UBC 1997-WSEC	1998
New	Two Story SFR - 1997 UBC		Plan: 1917	1998
New	Approved Basic #98-116653BP		Plan: #2115 Two Story SFR - 1997 UBC	1998
New	Approved Basic #98-116645BP		Plan: #1915 Two Story SFR - 1997 UBC	1998

Accessory Dwelling Units

Index # - File Name: 1.0022 - Single Family Dwellings Data\_Snohomish County.pdf

New	2-Story SFR w/attached Garage	1997-UBC	1997-WSEC	1998
New	Two Story SFR - 1997 UBC		Plan: 1715	1998
New	Two Story SFR - 1997 UBC			1998
New	Two Story SFR - 1997 UBC		Plan: #1915	1998
New	Approved Basic #98-108798BP		Plan 2161 Two Story SFR - 1997 UBC	1998
New	Two Story SFR with Attached Garage			1998
New	2- Story with attached garage - 1994 UBC			1998
New	40x66, 1997 Goldenwest			1998
New	Two Story SFR - 1994 UBC		Plan #G 517 A	1998
New	Two Story SFR - 1997 UBC		Plan #G-507-a	1998
New	Two Story SFR - 1997 UBC		Plan #A-311 a/b	1998
New	Two Story SFR - 1997 UBC		Plan #B-406 c/d	1998
New	Approved Basic #98-109460BP		Plan # A-311 a/b Two Story SFR - 1997 UB	1998
New	Two Story SFR - 1997 UBC		Plan #B-409 e/f	1998
New	Approved Basic #98-109468BP		Plan # B-406 c/d Two Story SFR - 1997 U	1998
New	Approved Basic #98-109460BP		Plan # A-311 a/b Two Story SFR - 1997 UB	1998
New	Two Story SFR - 1997 UBC		Plan #G-517-a/b	1998
New	Two Story SFR - 1994 UBC		Plan: B406 C3	1998
New	Two Story SFR - 1994 UBC		Plan: #410 B-3	1998
New	Two Story SFR - 1994 UBC		Plan: # G407-A-3	1998
New	2-Story SFR w/attached garage			1998
New	2042 s.f. rambler			1998
New	Two-story SFR w/attached garage		Plan #A411B	1998
New	Two Story SFR - 1994 UBC		Plan: B 406 DP	1998
New	1998 Golden West OK48001F 27 x 48			1998
New	Rambler with unfinished daylighted basement - 1997 UBC			1998
New	56 x 25 6 (1998) Fleetwood		Install temporary sediment / erosion control as necessary prior to	1998
New	Rambler style SFR w/attached garage			1998
New	Rambler style SFR w/attached garage.			1998
New	28x66, 1995 Fleetwood			1998
New	2698 sf 2-story Duplex w/744 sf garage			1998
New	2698 sf 2-story Duplex w/744 sf garage			1998
New	Duplex with attached garage - 1994 UBC			1998
New	Two Story SFR with Attached Garage			1998
New	2116 sf 2-story w/280 sf covered deck/porch.			1998
New	2-Story Duplex w/attached garages			1998
New	2-Story Duplex w/attached garages			1998
New	Rambler Style SFR - 1994 UBC			1998
New	Approved Basic #96-103850BP		Two Story SFR - 1994 UBC	1998
New	Approved Basic #97-102037 BP		Plan #212-3 SFR w/finished basement - 1994 U	1998
New	Approved Basic #97-102039BP		Plan #467-3 Two Story SFR - 1994 UBC	1998
New	Approved Basic #96-103849BP		Two Story SFR - 1994 UBC	1998
New	Approved Basic #96-103850BP		Two Story SFR - 1994 UBC	1998
New	Approved Basic #96-103849BP		Two Story SFR - 1994 UBC	1998
New	Approved Basic #97-102039BP		Plan #467-3 Two Story SFR - 1994 UBC	1998
New	Approved Basic #97-102037 BP		Plan #212-3 SFR w/finished basement - 1994 U	1998
New	1998 Silvercrest M03 66 x 40		*** STOP WORK POSTED 7/30/98 at 12:30 p.m. by T.Irish. RE: C	1998

Accessory Dwelling Units

Index # - File Name: 1.0022 - Single Family Dwellings Data\_Snohomish County.pdf

New	1998 - 28 x 64 Palm Harbor		1998
New	Rambler - 2062 Sq Ft		1998
New	2 Story w/3 Car		1998
New	2-Story SFR w/attached Garage		1998
New	Two Story SFR - 1997 UBC		1998
New	Two-story SFR w/attached garage - 1997 UBC		1998
New	Approved Basic #98-104640 BP Two Story w/unfinished basement - 1994 UBC		1998
New	Approved Basic #98-104728BP Two Story SFR - 1994 UBC	Plan #	1998
New	Approved Basic #98-104728BP Two Story SFR - 1994 UBC	Plan #	1998
New	2-Story Duplex with attached double garages.		1998
New	Approved Basic #98-108653BP	(6 Bedrooms/3 each unit) 2-Story Dup	1998
New	Approved Basic #98-108653BP	(6 Bedrooms/3 each unit) 2-Story Dup	1998
New	Two Story Duplex with Attached Garage		1998
New	Approved Basic #98-108653BP 2-Story Duplex with attached double garages.		1998
New	2 Stroy SFR with attached garage - 1994 UBC		1998
New	Split level with attached garage and unfinished basement - 1994 UBC		1998
New	2- Story SFR with attached garage - 1997 UBC		1998
New	Two Story SFR with Basement		1998
New	Two-story SFR w/attached garage		1998
New	Approved Basic #98-105292BP	Plan #8730 Two Story SFR w/fi	1998
New	Two Story SFR - 1994 UBC	Plan #8620	1998
New	Two Story SFR - 1994 UBC	Builders Plan #8730	1998
New	Two-story SFR w/attached garage		1998
New	2 Story w/2 Car		1998
New	Approved Basic #98-105289BP	Plan #8620 Two Story SFR - 1994 UB	1998
New	2 Story Duplex - 1994 UBC		1998
New	3584 sf 2-story Duplex w/644 sf garage and 56 sf covered porch		1998
New	Two-story SFR w/attached garage		1998
New	28x40, 1997 Liberator		1998
New	28x60, 1985 Brigadier Tempo		1998
New	Approved Basic #95-108472BP	Plan #1446 Rambler Style SFR - 1994 U	1998
New	Approved Basic #95-108472BP	Plan 1446 Rambler Style SFR - 1994 UBC	1998
New	Approved Basic #95-109256BP	Plan #1520 Rambler Style SFR - 1994 UBC	1998
New	Approved Basic #95-108472BP	Plan 1446 Rambler Style SFR - 1994 UBC	1998
New	Approved Basic #95-109256BP	Plan #1520 Rambler Style SFR - 1994 UBC	1998
New	Approved Basic #95-108472BP	Plan 1446 Rambler Style SFR - 1994 UBC	1998
New	Tri-level with finished basement - 1997 UBC		1998
New	Approved Basic #95-109256BP	Plan #1520 Rambler Style SFR - 1994 UBC	1998
New	Approved Basic #95-108472BP	Plan 1446 Rambler Style SFR - 1994 UBC	1998
New	Approved Basic #95-109256BP	Plan #1520 Rambler Style SFR - 1994 UBC	1998
New	Approved Basic #98-106780 BP	Plan 1624 Two-story SFR - 1	1998
New	Approved Basic #95-109256BP	Plan #1520 Rambler Style SFR - 1994 UBC	1998
New	Approved Basic #95-109256BP	Plan #1520 Rambler Style SFR - 1994 UBC	1998
New	Approved Basic #95-108472BP	Plan 1446 Rambler Style SFR - 1994 UBC	1998
New	Approved Basic #95-109256BP	Plan #1520 Rambler Style SFR - 1994 UBC	1998
New	Approved Basic #95-108472BP	Plan 1446 Rambler Style SFR - 1994 UBC	1998
New	Approved Basic #95-109101BP	Plan 1688 Two Story SFR - 1994 UBC	1998

Accessory Dwelling Units

Index # - File Name: 1.0022 - Single Family Dwellings Data\_Snohomish County.pdf

New	Approved Basic #95-109101BP	Plan 1688	Two Story SFR - 1994 UBC	1998
New	Approved Basic #95-109111BP	Plan #1876	Two Story SFR - 1994 UBC	1998
New	Approved Basic #98-108806BP	Plan: # 1936 Split	SFR w/unfinished lower fl	1998
New	Approved Basic #95-109111BP	Plan #1876	Two Story SFR - 1994 UBC	1998
New	Approved Basic #95-109101BP	Plan 1688	Two Story SFR - 1994 UBC	1998
New	Approved Basic #95-109102BP	Plan 1477	Rambler Style SFR - 1994 UBC	1998
New	Approved Basic #95-109111BP	Plan #1876	Two Story SFR - 1994 UBC	1998
New	Approved Basic #95-109102BP	Plan 1477	Rambler Style SFR - 1994 UBC	1998
New	Approved Basic #98-110563BP		2-Story SFR w/attached garage	1998
New	Approved Basic #97-103628BP	Plan #1581	Rambler Style SFR - 1994 UBC	1998
New	Approved Basic #95-109102BP	Plan 1477	Rambler Style SFR - 1994 UBC	1998
New	Approved Basic #95-109101BP	Plan 1688	Two Story SFR - 1994 UBC	1998
New	Approved Basic #98-108803BP		Plan 1750 Cal 1174 sf SFR w/56	1998
New	Approved Basic #98-108806BP		Plan 1936 Split 1174 sf SFR w/762 sf ur	1998
New	1174 sf SFR w/560 sf unfin basement & attached garage			1998
New	Approved Basic #98-108806BP		Plan 1936 Split 1174 sf SFR w/762 sf ur	1998
New	2 story sfr with 2 car garage			1998
New	3222 sf 2-story w/760 sf garage and 21 sf covered porch			1998
New	Rambler style SFR w/attached garage--w/bonus room up.			1998
New	Two Story SFR - 1997 UBC			1998
New	Rambler Style SFR - 1997 UBC			1998
New	2 Story SFR with attached garage - 1994 UBC			1998
New	Rambler Style SFR - 1997 UBC			1998
New	SFR w/finished basement - 1994 UBC			1998
New	SFR w/finished basement - 1994 UBC			1998
New	2-Story SFR w/attached garage & 612-sf Unfin. Bonus room over garage.			1998
New	Approved Basic #96-109445BP	Plan #1715	Two Story SFR - 1994 UBC	1998
New	Approved Basic #96-109445BP	Plan #1715	Two Story SFR - 1994 UBC	1998
New	Rambler Style SFR - 1994 UBC			1998
New	Ramber Style SFR - 1994 UBC			1998
New	2- story with attached garage - 1994 UBC			1998
New	Approved Basic #96-105888BP		Two Story SFR - 1994 UBC	1998
New	Approved Basic #96-101276BP	Plan 2005	Two Story SFR - 1994 UBC Archived ir	1998
New	Approved Basic #96-109445BP	Plan #1715	Two Story SFR - 1994 UBC	1998
New	Approved Basic #96-105888BP		Two Story SFR - 1994 UBC	1998
New	Approved Basic #96-107790BP		Two Story SFR - 1994 UBC	1998
New	Approved Basic #97-109910BP	Plan# 1785	Rambler with attached garage - 1994	1998
New	2 Story SFR with attached garage - 1994 UBC			1998
New	2 Story SFR with attached garage - 1994 UBC			1998
New	Approved Basic #95-108882BP	Plan #1315	Split Level SFR - 1994 UBC	1998
New	27x56, 1997, Palm Harbor			1998
New	1632 sf 2-story w/400 sf garage and 90 sf covered porch			1998
New	2 Story SFR with attached garage - 1994 UBC			1998
New	Rambler Style SFR - 1997 UBC		Plan: 4 Bedroom	1998
New	Rambler Style SFR - 1997 UBC		Plan: 2 Bedroom w/optional porch	1998
New	Rambler Style SFR - 1997 UBC		Plan: 3 Bedroom	1998
New	1984 Fleetwood Vogue 15 x 70			1998



Accessory Dwelling Units

Index # - File Name: 1.0022 - Single Family Dwellings Data\_Snohomish County.pdf

New	14x56, 1985 Fleetwood		1998
New	28x44, 1990 Fleetwood		1998
New	Approved Basic 95-107925BP	(Builders Plan #1740) 0 lot line structure Two Story SFR - 19	1998
New	Approved Basic #95-108149BP	(0 lot line structure) Plan #2043 Two Story SFR - 1994 UBC	1998
New	Approved Basic #95-108149BP	(0 lot line structure) Plan #2043 Two Story SFR - 1994 UBC	1998
New	Approved Basic #96-100749BP	Plan #1618 SFR w/finished basement - 1994 UBC	1998
New	Approved Basic #95-108527BP	SFR w/unfinished basement 1994 UBC	1998
New	Approved Basic #95-108526BP	SFR w/unfinished basement 1994 UBC	1998
New	Approved Basic #95-108527BP	SFR w/unfinished basement 1994 UBC	1998
New	Approved Basic #95-108527BP	SFR w/unfinished basement 1994 UBC	1998
New	Approved Basic #95-108526BP	SFR w/unfinished basement 1994 UBC	1998
New	Approved Basic #95-108527BP	SFR w/unfinished basement 1994 UBC	1998
New	Approved Basic #95-108526BP	SFR w/unfinished basement 1994 UBC	1998
New	Approved Basic #95-108527BP	SFR w/unfinished basement 1994 UBC	1998
New	Approved Basic #95-108526BP	SFR w/unfinished basement 1994 UBC	1998
New	Approved Basic #95-108527BP	SFR w/unfinished basement 1994 UBC	1998
New	Approved Basic #95-108526BP	SFR w/unfinished basement 1994 UBC	1998
New	Approved Basic #95-108526BP	SFR w/unfinished basement 1994 UBC	1998
New	2- Story SFR with attached garage -	1994 UBC	1998
New	Two Story SFR -	1994 UBC	1998
New	Approved Basic Plan #98-102276BP	Plan #1533 Two Story SFR - 1994 - UBC	1998
New	Two Story SFR -	1994 UBC	1998
New	Approved Basic Plan #98-102276BP	Plan #1533 Two Story SFR - 1994 - UBC	1998
New	Two Story SFR -	1994 UBC	1998
New	Two Story SFR -	1994 UBC	1998
New	Two Story SFR		1998
New	2263 sf rambler w/481 sf garage and 368 sf covered deck/porch		1998
New	Approved Basic #98-101706BP	Plan #1639 2 story sfr with 2 car garage	1998
New	Two Story SFR with attached Garage		1998
New	12 x 56 - 1969 Fleetwood Mobile Home.		1998
New	28 x 56 - 1998 Palm Harbor Mobile Home		1998
New	Rambler w/2 Car		1998
New	12 X 65 single wide mobile home		1998
New	Rambler w/2 Car		1998
New	1344 sf with 648 s.f. basement & 2 car garage		1998
New	1674 s.f. rambler with 3 car garage		1998
New	1674 sf rambler w/792 sf garage		1998
New	Rambler with Attached Garage		1998
New	Rambler with Attached Garage		1998
New	Approved Basic #95-108527BP	SFR w/unfinished basement 1994 UBC	1998
New	Approved Basic #95-108526BP	SFR w/unfinished basement 1994 UBC	1998
New	2 Story w/3 Car		1998
New	2-Story with attached garage -	1994 UBC	1998
New	Approved Basic 95-107925BP	(Builders Plan #1740) 0 lot line structure Two Story SFR - 19	1998
New	Approved Basic 95-107925BP	(Builders Plan #1740) 0 lot line structure Two Story SFR - 19	1998
New	Approved Basic 95-107925BP	(Builders Plan #1740) 0 lot line structure Two Story SFR - 19	1998
New	Approved Basic #95-108149BP	(0 lot line structure) Plan #2043 Two Story SFR - 1994 UBC	1998

Accessory Dwelling Units

Index # - File Name: 1.0022 - Single Family Dwellings Data\_Snohomish County.pdf

New	Approved Basic #95-108149BP	Plan 2043 0 lot line stucture	Two Story SFR -	1998
New	Approved Basic #95-107925BP	Plan #1740	Two Story SFR - 1994 UBC	1998
New	Approved Basic #95-108149BP	(0 lot line structure)	Plan #2043 Two Story SFR - 1994 UBC	1998
New	Approved Basic 95-107925BP	(Builders Plan #1740) 0 lot line stucture	Two Story SFR - 1994 UBC	1998
New	2 story w/2 car			1998
New	Rambler style SFR w/attached garage.			1998
New	Rambler style SFR with attached garage	--	1994 UBC	1998
New	Rambler style SFR w/attached garage.			1998
New	Rambler style SFR with attached garage	---	1994 UBC	1998
New	2-story Split Entry SFR w/attached Garage.			1998
New	Two Story, Split Entry SFR w/attached garage			1998
New	Rambler Style SFR - 1994 UBC			1998
New	Rambler Style SFR - 1994 UBC			1998
New	Rambler Style SFR - 1994 UBC			1998
New	Two Story SFR - 1994 UBC			1998
New	Rambler Style SFR - 1994 UBC	Plan: SKG 1170		1998
New	Rambler Style SFR - 1994 UBC	Plan: CAN 1390		1998
New	Rambler Style SFR - 1994 UBC			1998
New	56 x 24 Mobile Home			1998
New	2 story SFR w/ 2 car garage			1998
New	Approved Basic #97-101885BP	Plan #1800	Two Story SFR - 1994 UBC	1998
New	1611 sf rambler w/410 sf garage and 80 sf covered deck/porch			1998
New	Approved Basic #98-104838BP	Plan #1750	SFR w/unfinished b	1998
New	Approved Basic #98-104844BP	Plan #93-101	Rambler Style SFR	1998
New	Approved Basic #98-104838	Plan #1750	Rambler Style SFR - 1994 UBC	1998
New	Approved Basic #97-101885BP	Plan #1800	Two Story SFR - 1994 UBC	1998
New	1887 sf Rambler with attached garage - 1994 UBC			1998
New	1691 sf Rambler with attached garage - 1994 UBC			1998
New	Approved Basic #98-104838BP	Plan #1750	SFR w/unfinished b	1998
New	Two-story SFR			1998
New	2 story sfr with 3 car garage			1998
New	2260 s.f. rambler with 2 car garage			1998
New	24x60, 1985 Fleetwood			1998
New	Approved Basic #97-106334BP	Plan 1938	Two Story SFR - 1994 UBC	1998
New	2-Story SFR w/attached garage			1998
New	Approved Basic #96-108624BP	Plan #1365	SFR w/finished basement - 1994 UBC	1998
New	2 Story w/3 Car			1998
New	Two Story Duplex w/unfinished lower floor - 1994 UBC			1998
New	Approved Basic #98-102013BP	Plan #1450	Two Story Duplex w/unfi	1998
New	Approved Basic #98-102013BP	Plan #1450	Two Story Duplex w/u	1998
New	1459 s.f. sfr with 919 unfinished basement & 2 car garage			1998
New	1459 s.f. sfr with 919 unfinished basement & 2 car garage			1998
New	Rambler with attached garage, unfinished basement and deck - 1994 UBC			1998
New	2 story sfr with 2 car garage			1998
New	Rambler style SFR w/attached garage			1998
New	Rambler style SFR w/attached garage.			1998
New	28x35 (1986) Fleetwood			1998

Accessory Dwelling Units

Index # - File Name: 1.0022 - Single Family Dwellings Data\_Snohomish County.pdf

New	Rambler Style SFR - 1994 UBC	1998
New	2580sf Rambler style SFR with attached garge -- 1994 UBC	1998
New	Rambler style SFR w/attached garage	1998
New	1170 sf rambler with 2 car garage	1998
New	Rambler Style SFR - 1997 UBC	1998
New	Two-story SFR w/attached garage	1998
New	3710 sf 2-story w/2700 sf finished basement, 320 sf carport, and 408 sf covered porch	1998
New	Approved Basic #98-106223BP Plan #2070 Two Story SFR - 1994	1998
New	Approved Basic #96-100763BP Two Story SFR - 1994 UBC (2/3 car option)	1998
New	Approved Basic #96-100763BP Two Story SFR - 1994 UBC (2/3 car option)	1998
New	2- Story SFR with attached garage - 1994 UBC	1998
New	Approved Basic #98-103479BP Plan #1922 Two Story SFR - 1994 UBC	1998
New	1928 sf 2-story w/446 sf garage and 38 sf covered deck/porch	1998
New	Approved Basic #95-110544BP Plan: 2137 2/3 2 story SFR-2 or 3 car garage- 1994	1998
New	Approved Basic #95-110105BP Plan 1715 Two Story SFR - 1994 UBC	1998
New	Approved Basic #96-109132BP Plan #2154 Two Story SFR - 1994 UBC	1998
New	Approved Basic #96-109289BP OPTION: Approved Two Story SFR - 1994 UBC	1998
New	Approved Basic #96-109288BP Two Story SFR - 1994 UBC Plan 1887 -2/3	1998
New	Approved Basic #96-109132BP Plan #2154 Two Story SFR - 1994 UBC	1998
New	Approved Basic #97-111182BP Plan #2070 Two Story SFR - 1994 UBC	1998
New	Approved Basic #96-109288BP Two Story SFR - 1994 UBC Plan 1887 -2/3	1998
New	Approved Basic #97-111529BP Plan #2120 Two Story SFR - 1994 UBC	1998
New	Two Story SFR - 1994 UBC	1998
New	Two Story SFR with Attached Garage	1998
New	Approved Basic #95-109591BP Two Story SFR - 1994 UBC	1998
New	Approved Basic #98-106223BP Plan #2070 Two Story SFR - 1994	1998
New	28x60 (1979) Kit	1998
New	Approved Basic #98-106223BP Plan #2070 Two Story SFR - 1994	1998
New	Two-story SFR w/unfin basement & attached garage	1998
New	48 X 27 - 1998 Oakwood	1998
New	1998 Silvercrest 28 x 66	1998
New	2 story SFR w/garage	1998
New	28x66 1997 Marlett	1998
New	1 bdrm SFR w/832sf 2 car garage below	1998
New	28 X 40 1999 Double wide First Edition	1998
New	Two-story SFR w/attached garage	1998
New	1998 Doublewide Fleetwood ( 28 x 66 )	1998
New	1997 Palm Harbor 27 x 44	1998
New	48x27, 1998 Golden West	1998
New	1998 Fleetwood 24 x 52	1998
New	1998 Golden West OC66001F 28 x 66	1998
New	28 x 66 Golden West Mobile Home	1998
New	Rambler with Attached Garage	1998
New	1868 s.f. rambler with 2 car garage	1998
New	1940 s.f. rambler with 3 car garage	1998
New	28x52, 1998 Redman	1998
New	1998 Fleetwood 28 x 56	1998

Accessory Dwelling Units

Index # - File Name: 1.0022 - Single Family Dwellings Data\_Snohomish County.pdf

New	2676 sf 2-story Duplex w/876 sf garage and 72 sf covered porches		1998	
New	40x27, 1997 Liberator		1998	
New	1996 Fuqua 56 x 39		1998	
New	28x64 (1997) Palm Harbor		1998	
New	28 x 58 (1993) Fugue		1998	
New	1998 - 28 x 51 - Fleetwood		1998	
New	28 x 46 1990 Barrington		1998	
New	Two Story SFR with Attached Garage		1998	
New	Approved Basic #95-109726BP	Two Story SFR - 1994 UBC	Option Approved - Elv. C & 3i	1998
New	Approved Basic #96-102270BP	Plan #2054	Two Story SFR - 1994 UBC	1998
New	Approved Basic #95-109726BP	Two Story SFR - 1994 UBC	Option Approved - Elv. C & 3i	1998
New	Two Story SFR - 1994 UBC			1998
New	Approved Basic #96-106959BP	Plan #2108	Two Story SFR - 1994 UBC	1998
New	Approved Basic #95-106646BP	Plan #2444	Two Story SFR - 1994 UBC	1998
New	Rambler Style SFR - 1994 UBC			1998
New	Approved Basic #96-102874BP	Plan #2259	Two Story SFR - 1994 UBC	1998
New	Approved Basic #95-106646BP	Plan #2444	Two Story SFR - 1994 UBC	1998
New	Approved Basic #96-106959BP	Plan #2108	Two Story SFR - 1994 UBC	1998
New	Approved Basic #97-104556BP	Plan #1389	Two Story SFR - 1994 UBC	1998
New	Approved Basic #97-106548BP	Plan #2143	Two Story SFR - 1994 UBC	1998
New	Approved Basic #97-104831BP	Plan 1639	Two Story SFR - 1994 UBC	1998
New	Approved Basic #97-101584BP	Plan #1895	Two Story SFR - 1994 UBC	1998
New	Approved Basic #96-102270BP	Plan #2054	Two Story SFR - 1994 UBC	1998
New	Approved Basic #97-111003BP	Plan #2018	Two Story SFR - 1994 UBC	1998
New	Approved Basic #96-102270BP	Plan #2054	Two Story SFR - 1994 UBC	1998
New	Approved Basic #95- 108133BP	Plan #1655	Tri-Level SFR - 1994 UBC	1998
New	Approved Basic #95-108812BP	Plan #1384	Two Story SFR - 1994 UBC	1998
New	Approved Basic #95- 108133BP	Plan #1655	Tri-Level SFR - 1994 UBC	1998
New	Approved Basic #96-102270BP	Plan #2054	Two Story SFR - 1994 UBC	1998
New	Approved Basic #95- 108133BP	Plan #1655	Tri-Level SFR - 1994 UBC	1998
New	Approved Basic #95-109726BP	Two Story SFR - 1994 UBC	Option Approved - Elv. C & 3i	1998
New	Approved Basic #98-104213BP		Plan #9514 Two Story SFR - 199	1998
New	Two Story SFR - 1994 UBC			1998
New	Approved Basic #98-104213BP		Plan #9514 Two Story SFR - 199	1998
New	Rambler with Unfinished Basement and Attached Garage			1998
New	2 story w 2 car			1998
New	28 x 52 - 1995 - Marlette			1998
New	2772 sf 2-story with 676 sf garage and 416 sf covered deck/porch			1998
New	Approved Basic #96-101083BP	Two Story Duplex - 1994 UBC		1998
New	Approved Basic #96-101074BP	Two Story Duplex - 1994 UBC		1998
New	2 story SFR to be attached to existing Garage - 1997 UBC			1998
New	2-Story SFR w/attached garage.			1998
New	1998 - 30 x 50 Beechwood			1998
New	Approved Basic #97-105464BP	Plan: Kira	SFR w/unfinished lower floor	1998
New	Approved Basic #97-105464BP	Plan: Kira	SFR w/unfinished lower floor	1998
New	Approved Basic #97-105464BP	Plan: Kira	SFR w/unfinished lower floor	1998
New	Approved Basic #97-105888BP	Plan #1500	SFR w/unfinished lower floor - 1	1998

Accessory Dwelling Units

Index # - File Name: 1.0022 - Single Family Dwellings Data\_Snohomish County.pdf

New	2-story SFR w/attached garage.		1998
New	Rambler with attached garage - 1994 UBC		1998
New	Two-story duplex w/attached garages		1998
New	Two-story duplex w/attached garages		1998
New	2 story SFR with attached garage		1998
New	2 story SFR with attached garage		1998
New	Approved Basic #97-107299BP	Plan #2241/3 Two Story SFR - 1994 UBC	1998
New	Approved Basic #97-107296BP	Plan #2490 C/3 Two Story SFR - 1994 UBC	1998
New	2865 sf 2-story w/680 sf garage and 48 sf covered deck/porch		1998
New	Two-story SFR w/attached garage		1998
New	2691 sf 2-story w/778 sf garage and 48 sf covered deck/porch		1998
New	2 Story w/3/car		1998
New	Rambler style SFR with attached garage - 1994 UBC		1998
New	Rambler style SFR with attached garage		1998
New	2 story SFR w/ attached garage		1998
New	2 story sfr with 2 car garage		1998
New	Approved Basic #97-104957BP	Plan #1795-3 Two Story SFR - 1994 UBC	1998
New	3889 sf 2-story w/912 sf garage and 200 sf carport		1998
New	Tri-level w/3 Car		1998
New	2-Story SFR w/attached garage.		1998
New	2772 sf 2-story w/796 sf garage and 200 sf covered deck/porch		1998
New	Two Story SFR - 1997 UBC		1998
New	Two Story SFR - 1997 UBC		1998
New	1430 sq. ft. unfinished/unheated basement - 1997 UBC		1998
New	Two-story SFR w/attached garage		1998
New	Two story SFR w/attached garage		1998
New	2 story sfr with 3 car garage		1998
New	2-Story SFR w/attached garage		1998
New	2 story SFR with attached garage		1998
New	2 story sfr with 3 car garage		1998
New	2 story sfr with 2 car garage		1998
New	3374 sf 2-story w/850 sf garage		1998
New	2 story SFR with attached garage		1998
New	2 story SFR w/ attached garage		1998
New	Two Story SFR - 1994 UBC		1998
New	2-Story SFR w/attached garage		1998
New	Rambler style SFR with attached garage and covered porch		1998
New	2 Story SFR with attached garage and covered porch - 1997 UBC		1998
New	2 Story SFR with attached garage - 1997 UBC		1998
New	Waverly Crest (Fleetwood ) Triple wide		1998
New	40.5 X 42 Palm Harbor 1998		1998
New	Two-story SFR w/attached garage		1998
New	Rambler Style SFR - 1997 UBC	Plan: 3 Bedroom A	1998
New	2 Story SFR with attached garage - 1994 UBC		1998
New	2 story SFR with attached garage, breezeway and gazebo		1998
New	Rambler style SFR w/attached 3-car garage.		1998
New	2 story SFR w/ attached garage		1998

Accessory Dwelling Units

Index # - File Name: 1.0022 - Single Family Dwellings Data\_Snohomish County.pdf

New	Approved Basic #96-110602BP	Plan 2031w/bonus	Two Story SFR - 1994 U	1998
New	Two-story SFR w/attached garage			1998
New	Approved Basic #97-109196BP	Plan #1545	Two Story SFR - 1994 UBC	1998
New	Approved Basic 98-101570BP	Plan #1674	Rambler w/3 car	1998
New	Approved Basic #97-111526BP	1554 sf rambler w/480 sf garage and 156 sf covered deck/porch		1998
New	Approved Basic #97-109196BP	2 story sfr with 2 car garage		1998
New	Rambler Style SFR - 1994 UBC			1998
New	Approved Basic #96-109445BP	Plan #1715	Two Story SFR - 1994 UBC	1998
New	Approved Basic #96-101277BP	Plan 1732	Two Story SFR - 1994 UBC	1998
New	Approved Basic #96-109445BP	Plan #1715	Two Story SFR - 1994 UBC	1998
New	Approved Basic #96-101276BP	Plan 2005	Two Story SFR - 1994 UBC	1998
New	Approved Basic #96-109445BP	Plan #1715	Two Story SFR - 1994 UBC	1998
New	Approved Basic #96-101276BP	Plan 2005	Two Story SFR - 1994 UBC	1998
New	Approved Basic #96-101277BP	Plan 1732	Two Story SFR - 1994 UBC	1998
New	Approved Basic #96-100375BP	Plan #1502	Rambler Style SFR - 1994 UBC	1998
New	Approved Basic #96-100375BP	Plan #1502	Rambler Style SFR - 1994 UBC	1998
New	Approved Basic #96-109445BP	Plan #1715	Two Story SFR - 1994 UBC	1998
New	Approved Basic #96-109445BP	Plan #1715	Two Story SFR - 1994 UBC	1998
New	Approved Basic #96-101276BP	Plan 2005	Two Story SFR - 1994 UBC	1998
New	Approved Basic #96-109445BP	Plan #1715	Two Story SFR - 1994 UBC	1998
New	Approved Basic #96-101276BP	Plan 2005	Two Story SFR - 1994 UBC	1998
New	2-Story SFR w/attached Garage.			1998
New	2 story sfr with 2 car garage			1998
New	1008 s.f. cabin with 288 s.f. loft. Final inspection by Hal Reeves 12/16/99.			1998
New	2-Story SFR w/attached garage & covered porches	1997-UBC		1998
New	2 Story SFR w/ attached Garage			1998
New	2 story SFR			1998
New	Rambler with attached garage - 1997 UBC			1998
New	2831 sf 2-story w/814 sf garage and 400 sf covered deck/porch			1998
New	Two-story SFR w/attached garage			1998
New	Two-story SFR w/attached garage			1998
New	Two-story SFR w/attached garage	Plan 3510B/35G		1998
New	2 Story w/3 car			1998
New	Two-story SFR w/attached garage			1998
New	Approved Basic #96-103338BP	Plan #2645 A/B	Two Story SFR -1994 UBC	1998
New	2 story w/3 car & covered porch			1998
New	Two Story SFR - 1994 UBC			1998
New	2-Story SFR w/attached garage	Note: Minor changes to structural plans submitted on 9/18/98		1998
New	2 story w/3 car			1998
New	Two Story SFR with Attached Garage			1998
New	40 x 50 (1998) Marlette			1998
New	Approved Basic #96-105337BP	Two Story SFR - 1994 UBC		1998
New	2 story SFR with 1147sf atached	Accessory Apartment located in basement		1998
New	2 Story w/3 Car			1998
New	2 Story SFR with attached garage - 1994 UBC			1998
New	Rambler style SFR w/attached garage			1998
New	Rambler Style SFR w/attached garage			1998

Accessory Dwelling Units

Index # - File Name: 1.0022 - Single Family Dwellings Data\_Snohomish County.pdf

New	2-Story SFR w/attached garage		1998
New	2 story sfr with 4 car garage		1998
New	2 story SFR with attached garage - 1994 UBC		1998
New	Two Story SFR with Attached Garage		1998
New	Two-story SFR w/attached garage		1998
New	Rambler Style SFR w/attached garage.		1998
New	Approved Basic #98-103395BP	Plan #2490K-3 Two Story SFR -	1998
New	2-Story SFR w/attached garage		1998
New	2 story SFR w/ attached garage		1998
New	Tri-Level Style SFR w/attached garage.		1998
New	Two Story SFR - 1994		1998
New	2 Story w 3 car		1998
New	Two Story SFR - 1994 UBC	Plan #K3216	1998
New	Two Story SFR - 1994		1998
New	Approved Basic #95-109478BP Two Story SFR - 1994 UBC		1998
New	Approved Basic #97-108460 Two-story SFR w/attached garage		1998
New	2 story SFR w/ 3 car garage		1998
New	Approved Basic #97-108460 Two-story SFR w/attached garage		1998
New	Two Story SFR - 1994 UBC		1998
New	Two Story SFR - 1994 UBC	Plan #2646X	1998
New	Two Story SFR - 1994 UBC		1998
New	768 s.f. rambler with 768 s.f. garage		1998
New	Two Story SFR - 1997 UBC	Plan #2646	1998
New	Two Story SFR - 1994		1998
New	Two Story SFR - 1994		1998
New	Two Story SFR - 1994		1998
New	Approved Basic #95-109272BP Two Story SFR - 1994 UBC		1998
New	Approved Basic #95-109478BP Two Story SFR - 1994 UBC		1998
New	Approved Basic #95-109478BP Two Story SFR - 1994 UBC		1998
New	2 story sfr w/ 3 car garage		1998
New	Approved Basic #97-108460 Two-story SFR w/attached garage		1998
New	Approved Basic #95-109478BP Two Story SFR - 1994 UBC		1998
New	2 Story w/3 Car		1998
New	2 Story w/3 Car		1998
New	Approved Basic #95-109478BP Two Story SFR - 1994 UBC		1998
New	Rambler Style SFR - 1994 UBC		1998
New	Approved Basic #95-109272BP Two Story SFR - 1994 UBC		1998
New	Approved Basic #95-109478BP Two Story SFR - 1994 UBC		1998
New	Rambler w/3 car garage		1998
New	Approved Basic #95-109787BP Two Story SFR - 1994 UBC		1998
New	Approved Basic #98-103602BP	Plan #47 Two Story SFR - 199	1998
New	Approved Basic #95-109478BP Two Story SFR - 1994 UBC		1998
New	2550 sf rambler w/640 sf garage and 62 sf covered deck/porch		1998
New	Approved Basic #95-109272BP Two Story SFR - 1994 UBC		1998
New	Approved Basic #95-109478BP Two Story SFR - 1994 UBC		1998
New	Approved Basic #97-108560 Two-story SFR w/attached garage		1998
New	Two-story SFR w/attached garage	Builders Plan 2635/2-3	1998

Accessory Dwelling Units

Index # - File Name: 1.0022 - Single Family Dwellings Data\_Snohomish County.pdf

New	2 story SFR with attached garage	1998
New	2 story SFR with attached garage	1998
New	2450 sf 2-story w/648 sf garage and 168 sf covered deck/porch	1998
New	2250 sf 2-story with 734 sf garage and 144 sf covered deck/porch	1998
New	2205 sf 2-story w/467 sf garage and 80 sf covered deck/porch	1998
New	2 Story w/ 4 Car	1998
New	2-Story SFR w/attached garage.	1998
New	40 x 66 1998 Goldenwest Classic	1998
New	Two Story SFR with Attached Garage	1998
New	2-Story SFR w/attached garage.	1998
New	2367 sf 2-story with 677 sf garage and 24 sf covered deck/porch	1998
New	2 story sfr with 2 car garage	1998
New	1998 Golden West 66 x 41	1998
New	2 Story SFR with attached garage - 1994 UBC	1998
New	3-Story SFR	1998
New	Rambler with attached garage - 1994 UBC	1998
New	2687 sf 2-story w/696 sf unfinished basement, 936 sf garage and 260 sf covered deck/porch	1998
New	1996 Fleetwood 28 x 60	1998
New	DO NOT PROCEED! NSF CHECK 5/12/98. QUESTIONS: CALL CAROLYN X2344	story SFR with att
New	Two-story SFR & attached garage	1998
New	808 sf 2-story with 72 sf covered porch	1998
New	Two Story SFR - 1994 UBC	Plan: #2578
New	1248 sf Rambler	1998
New	Rambler style SFR w/covered porch	1998
New	2nd Story SFR above existing garage - 816 sq. ft.	1998
New	850 sf Accessory Apt with garage and carport - 1997 UBC	1998
New	Rambler w/4 Car & Bonus Room	1998
New	1987 14 x 57 Skyview	1998
New	Two Story SFR with Unfinished Basement	1998
New	28 x 60 Barrington (1984).	1998
New	1336 sf Log Home with unfinished Basement - 1994 UBC	1998
New	Two-story SFR w/attached garage	1998
New	1 story SFR w/ basement & 3 car garage	1998
New	2 story SFR	1998
New	Approved Basic #97-105888BP	Plan #1500 SFR w/unfinished lower floor - :
New	1978 Kentwood 14 x 64	1998
New	Two Story SFR - 1994 UBC	1998
New	Rambler w/2 car	1998
New	23 5 x 44 (1991) Champion Sequire	1998
New	2 story sfr with 2 car garage	1998
New	855 sf detached accessory apartment	1998
New	Two story SFR w/attached garage-	1998
New	SFR	1998
New	Two Story SFR with Garage	1998
New	2178 sf 2-story w/960 sf unfinished basement and 576 sf garage	1998
New	SFR with daylight basement and attached garage	Note--Permit transferred to Martin and Linda
New	1997 Guerdon 42 x 48	1998



Accessory Dwelling Units

Index # - File Name: 1.0022 - Single Family Dwellings Data\_Snohomish County.pdf

New	Split level style SFR w/basement garage.	1998
New	Approved Basic #96-104451BP (Plan 1918-3) Two Story SFR - 1994 UBC	1998
New	Single wide mobile	1998
New	3353 sf 2-story with 1714 sf unfinished basement and 730 sf garage and 524 sf covered deck/pc	1998
New	840-sf SFR + 840-sf attached garage - 1994 UBC	1998
New	2 story sfr with 3 car garage	1998
New	2 Story w/Covered Porch	1998
New	28 x 56 1990 Silvercrest	1998
New	2-Story SFR w/attached garage.	1998
New	850 sf Detached Accessory Apt	1998
New	Two Story SFR w/unfinished basement - 1994 UBC	1998
New	24x56, 1978 Champion	1998
New	New SFR w/ garage	1998
New	2 story SFR with unfinished basement	1998
New	1998 27 x 40 Lazy-Z	1998
New	24 x 48 Mobile Home	1998
New	2 story sfr with unfinished basement and 2 car garage. Work cont. on 00-109514.	1998
New	2-Story SFR w/attached garage	1998
New	28 x 44 - 1994 - Fleetwood	1998
New	1878 sf 2-story w/477 sf garage and 84 sf covered deck/porch	1998
New	1998 27 x 62 Palm Harbor	1998
New	Split Entry SFR w/attached garage	1998
New	2 story sfr with 3 car garage	1998
New	2580sf 2-story w/745 sf garage and 470 sf covered deck/porch	1998
New	Two Story SFR with attached garage	1998
New	Two-story SFR w/attached garage	1998
New	2117 SF Rambler with attached garage - VOIDED per Contractor 1/24/97 - AF TRANSFERRED pe	1998
New	2- Story SFR with coverd porch & attached garage - 1994 UBC	1998
New	24 x 60 1977 Hillcrest Mobile Home(place on property in approx. 1977)	1998
New	Two Story SFR - 1994 UBC	1998
New	SFR w/attached garage	1998
New	14x66 (1995) Guerdon	1998
New	40x60 (1998) Silvercrest	1998
New	2 story SFR	1998
New	One-story SFR w/attached garage	1998
New	24 X 56 Corinthian 1980	1998
New	24x60, 1998 Skyline	1998
New	1998 Palm Harbor 27 x 49	1998
New	28 x 56 - 1979 Skyline Mobile Home.	1998
New	2-Story SFR w/attached Garage.	1998
New	1 story SFR	1998
New	28 x 60 (1998) Woodbridge	1998
New	26 x 44 - 1997 - Fuqua - Arbor Point .	1998
New	1428 sf rambler w/676 sf finished basement, and 768 sf garage and 16 sf covered deck/porch	1998
New	2 story sfr with 2 car garage	1998
New	One-story SFR w/finished basement & 3 car garage	1998
New	2-Story SFR	1998

Accessory Dwelling Units

Index # - File Name: 1.0022 - Single Family Dwellings Data\_Snohomish County.pdf

New	2 story sfr with 3 car garage	Wetland has septic odor. May be Health issue.	1998
New	SFR w/finished basement - 1994 UBC		1998
New	Approved Basic #95-108142BP	Plan 2195-2 SFR w/finished basement - 1994	1998
New	Approved Basic #96-105978BP	OPTION Approved: Double Wall Const. Two Story SFR - 1994	1998
New	Approved Basic #97-111879BP	Plan: 2554 SFR w/finished basement	1998
New	2 story SFR with daylighted and attached garage - 1994 UBC		1998
New	Approved Basic #96-105978BP	OPTION Approved: Double Wall Const. Two Story SFR - 1994	1998
New	Approved Basic #96-105978BP	OPTION Approved: Double Wall Const. Two Story SFR - 1994	1998
New	Approved Basic #98-101731BP	Plan 2211 Two Story SFR w/finished	1998
New	1998 - 26 8 x 56 Marlette		1998
New	2-Story SFR w/daylight basement & attached garage.		1998
New	1977 28 x 56 Silvercrest		1998
New	1999 Fleetwood 24 x 38		1998
New	28 x 52 - 1997 - Marlette-Pacifica		1998
New	Rambler with attached garage and unfinished basement - 1994 UBC		1998
New	Rambler Style Accessary Apartment - 1994 UBC		1998
New	Approved Basic #98-110504BP	Plan #2195 Split Level SFR - 1997 UBC	1998
New	SFR with loft and covered porch		1998
New	2 story sfr with 2 car garage		1998
New	Approved Basic #97-106334BP	Plan 1938 Two Story SFR - 1994 UBC	1998
New	1748 rambler, 25psf snow load area AH		1998
New	2609 sf 2-story w/694 sf garage and 56 sf covered deck/porch		1998
New	2-Story SFR w/attached garage		1998
New	40.5 x 62 - 1998 - Palm Harbor.		1998
New	Two Story SFR		1998
New	52x27 (1998) Goldwest		1998
New	1998 Palm Harbor Jackson 1057 27 x 56		1998
New	1998 Goldenwest Sunrise Dream Home 27 x 48		1998
New	2-Story SFR with covered porch - 1994 UBC		1998
New	2-Story SFR w/attached garage.		1998
New	868 (810 sq. ft. inside dim. used for living space for AA) sf Detached Accessory Apt with 754 sf attached		1998
New	SFR with daylight basement		1998
New	27x60 1998 Oakhurst		1998
New	28 x 64 - 1978 - Sunny Brook - Mobile Home. EXPIRED W/O FINAL. SEE 01-103235.		1998
New	Convert TD(97-107680) to guest house		1998
New	27 x 60 Dbl Wide Mobile Home		1998
New	24 -8 x 56 - 1998 - Fleetwood		1998
New	14 x 66 1983 - Rex Guesthouse Mobile Home		1998
New	1428 sf rambler w/596 sf garage and 208 sf covered deck/porch		1998
New	2 story SFR		1998
New	Two Story SFR - 1994 UBC		1998
New	14x66 1976 Corinthian		1998
New	2 story sfr with 3 car garage		1998
New	24 x 32 - 1981 Sequoia Champion		1998
New	24 x 60 1977 Fleetwood Barrington		1998
New	2 story w/basement & 2 car		1998
New	28x66, 1990 Goldenwest		1998

Accessory Dwelling Units

Index # - File Name: 1.0022 - Single Family Dwellings Data\_Snohomish County.pdf

New	2 story sfr with unfinished basement & 3 car garage		1998
New	2 Story w unfin Bsmt & 2 Car Garage		1998
New	2-Story SFR w/attached garage		1998
New	26x67 1998 Marlette Brookwood		1998
New	1989 Fleetwood		1998
New	2 Story w/3 Car Garage		1998
New	3740 s.f. tri-level with 3 car garage		1998
New	Mobile Home is existing on property 24 x 52 1970 Buddy		1998
New	Rambler with attached garage -1994 UBC		1998
New	SFR w/finished basement - 1994 UBC		1998
New	27 x 56 - 1987 Fleetwood		1998
New	Split Entry w/2 Car		1998
New	2 story SFR with daylight basement and attached garage		1998
New	1438 sf Rambler w/1387 sf garage and 104 sf covered deck/porch		1998
New	1996 28x48 Waverly Crest Mobile Home replacing existing SFR		1998
New	Rambler with Attached Garage		1998
New	Split Level SFR w/unfinished lower floor - 1994 UBC	Plan: 668	1998
New	Split Level SFR w/unfinished lower floor - 1994 UBC	Plan: 668	1998
New	Split Level with attached garage - 1994 UBC		1998
New	2- Story SFR with attached garage - 1994 UBC		1998
New	Two-story SFR w/attached garage		1998
New	Split level with unfinished basement		1998
New	Two-story SFR w/unfin basement & attached garage		1998
New	Daylight Basement SFR w/attached garage		1998
New	2 Story Duplex with attached garage - 1997 UBC	Builders No. 1333/642	1998
New	Two-story duplex with attached garages - 1997 UBC		1998
New	Rambler w/covered porch		1998
New	1998 Marlett 28 x 60		1998
New	27x 66, 1998 Palm Harbor		1998
New	2- Story SFR with attached garage - 1994 UBC		1998
New	1998 Fleetwood Waverly Crest 40 x 60		1998
New	2 story sfr with 3 car garage		1998
New	Split Entry w/2 Car		1998
New	Approved Basic #97-107334BP	Option Approved: 2-bedroom floor plan S	1998
New	Approved Basic #97-107334BP Split Level SFR w/unfinished lower floor - 1994 UBC		1998
New	Two Story SFR - 1994 UBC	Plan #1983	1998
New	Two Story SFR - 1994 UBC	Plan #1607	1998
New	1482 s.f. rambler with 2 car garage		1998
New	2-Story SFR w/attached garage & Cov. porch.		1998
New	14 x 66 1978 Nashua		1998
New	Two-story SFR		1998
New	1998 28 x 48 Guerden Mobile Home		1998
New	SFR with daylight basement and covered porch		1998
New	Two-story SFR w/attached garage		1998
New	2 Story with attached garage - 1994 UBC		1998
New	3596 sf 2-story w/970 sf garage and 140 sf covered deck/porch		1998
New	Two-story SFR w/attached garage		1998

Accessory Dwelling Units

Index # - File Name: 1.0022 - Single Family Dwellings Data\_Snohomish County.pdf

New	2 story sfr with unfinished basement & 3 car garage		1998
New	Rambler w/3 car		1998
New	2-Story SFR w/attached garage		1998
New	26 X 66 Fuqua Townhouse 1976, placed under expired permit 218422.		1998
New	1998 28 x 66 Palm Harbor		1998
New	42 x 56 - 1998 Ambercove		1998
New	14 x 60 1984 Fleetwood		1998
New	3038 s.f. rambler with 3 car garage		1998
New	1998 39 x 56 Triple Wide Fuqua		1998
New	1986 Kit Golden State 28 x 66 installed under expired application		1998
New	1969 Western Townhouse 24 x 60		1998
New	Convert 2-nd floor of existing garage/shop/storage building to living space (together with a bree		1998
New	2 story sfr with 2 car garage		1998
New	2 story SFR		1998
New	28 X 56 Skyline 1989		1998
New	24 x 60 (1978) Gilbralter		1998
New	1998 27 x 52 Goldenwest		1998
New	One-story SFR w/attached garage		1998
New	Peters contact-Ripley		1998
New	1 story sfr w/ attached garage		1998
New	1 story SFR w/ attached garage		1998
New	24 x44 Mobile Home		1998
New	Rambler style SFR w/attached garage.		1998
New	64 x 27 (1998) #3064		1998
New	2492 sf rambler w/1200 sf unfinished basement, 690 sf garage and 156 sf covered deck/porch		1998
New	2 Story w/Bsmt		1998
New	1394 rambler with 2 car garage		1998
New	Approved Basic #95-109460BP Two Story Duplex - 1994 UBC		1998
New	28x52, 1990 Redman		1998
New	2-Story SFR w/attached garage.		1998
New	24x65 (1974) Gentry		1998
New	Rambler Style SFR - 1994 UBC	Plan #1784	1998
New	Rambler Style SFR - 1994 UBC	Plan #1784	1998
New	Mobile Home Permit for Title Elimination - 24 x 64 - 1976 Four Seasons		1998
New	Rambler with Attached Garage		1998
New	SFR w/finished basement - 1994 UBC	Plan #A-8686	1998
New	Two Story SFR - 1994 UBC	Plan #1620	1998
New	Two Story SFR - 1994 UBC	Plan #2325-3R	1998
New	Two Story SFR - 1994 UBC	Plan 2009	1998
New	Two Story SFR - 1994 UBC	Plan #2325	1998
New	Two Story SFR - 1994 UBC	Plan 2009	1998
New	2 story sfr with 3 car garage		1998
New	2 Story with attached garage - 1994 UBC		1998
New	Two-story duplex w/attached garage		1998
New	Two-story duplex w/attached garage		1998
New	Rambler with attached garage and covered entry - 1994 UBC		1998
New	2 Story w Basement & 2 Car		1998

Accessory Dwelling Units

Index # - File Name: 1.0022 - Single Family Dwellings Data\_Snohomish County.pdf

New	1840 sf main floor w/1021 sf finished basement, 630 sf garage, and 390 sf covered deck/porch		1998
New	2 story sfr - 1994 UBC		1998
New	Rambler w/unfin bsmt		1998
New	2 story SFR w/ attached garage		1998
New	24 X 48 Fleetwood 1977		1998
New	1990 28 x 60 Fleetwood -- Doublewide (Finaled by A.Husby)		1998
New	1982 14 x 60 Fleetwood		1998
New	3 Story SFR - 1994 UBC		1998
New	Tri-level Style SFR w/attached garage.		1998
New	Approved Basic #97-100518BP	Plan #1683 Split level SFR - 1994 UBC	C 1998
New	Approved Basic #98-103332BP	Plan #1238	Rambler S 1998
New	Approved Basic #98-103332BP	Plan #1238 Rambler Style SFR - 1994 UB	1998
New	1250 sf rambler with 2 car garage		1998
New	Two-story SFR w/attached garage		1998
New	Approved Basic #98-103332BP	Plan #1238 Rambler Style SFR - 1	1998
New	Approved Basic #98-101832BP	Plan #1302A Rambler Style SFR - 19	1998
New	Approved Basic #98-103332BP	Plan #1238 Rambler Style SFR - 1	1998
New	Approved Basic #98-103332BP	Plan #1238 Rambler Style SFR - 1	1998
New	Approved Basic #98-101832BP	Plan #1302A Rambler Style SFR - 19	1998
New	Approved Basic #98-101832BP	Plan #1302A Rambler Style SFR - 19	1998
New	SFR w/unfinished basement - 1994 UBC		1998
New	Approved Basic #98-108660BP Rambler with attached garage - 1997 UBC		1998
New	Approved Basic #97-110975	Plan: 1088 Rambler Style SFR - 1994 UBC	1998
New	Approved Basic #95-110737BP Rambler Style SFR - 1994 UBC		1998
New	Approved Basic #95-110737BP Rambler Style SFR - 1994 UBC		1998
New	2 story sfr with unfinished basement and 2 car garage		1998
New	1415 s.f. rambler with 2 car garage		1998
New	Approved Basic #95-110737BP Rambler Style SFR - 1994 UBC		1998
New	Split Entry Style SFR w/attached garage.		1998
New	Rambler with attached Garage		1998
New	Rambler with attached Garage		1998
New	Approved Basic #97-110188BP	Plan #1031 C Split level SFR with attached garage	1998
New	Split level style SFR with attached garage, covered porch and deck		1998
New	Approved Basic #98-102441BP	Plan #1020 Rambler Style SFR - 19	1998
New	SFR		1998
New	Approved Basic #98-108660BP Rambler with attached garage - 1997 UBC		1998
New	Rambler with unfinished basement and attached garage -1994 UBC		1998
New	Approved Basic #97-107139BP	SFR w/unfinished basement - 1994 UBC	1998
New	1361 s.f. rambler with 2 car garage		1998
New	Rambler style SFR w/36-sf Covered porch		1998
New	10x55, 1964 Kithm		1998
New	28x52, 1981 Glenn River		1998
New	28x51, 1998 Fleetwood Celeb.		1998
New	1664 sf rambler w/162 sf covered porch		1998
New	1998 Marlette Brookwood #1961 27 x 67		1998
New	Work cont. on 99-114922.		1998
New	24x60, 1979 Buckingham		1998

Accessory Dwelling Units

Index # - File Name: 1.0022 - Single Family Dwellings Data\_Snohomish County.pdf

New Duplex w/attached garage	1998
New 28 x 51 (1997) Fleetwood Celebration	1998
New 2- Story with attached garage and covered porch - 1994 UBC	1998
New Phase one of two-story SFR w/attached garage. This phase includes 770 sf living area & 265 sf g	1998
New 2-story SFR w/ attached garage	1998
New 12x60 (1971) Lamplighter	1998
New 1998 Fleetwood 27 x 51	1998
New Approved Basic #97-102318BP Plan #1187 Rambler Style SFR - 1994 UBC	1998
New 1925 sf 2-story w/1031 sf garage and 168 sf covered porch	1998
New Two Story SFR w/finished basement - 1994 UBC	1998
New 1705 SF SFR with attached garage	1998
New 3060 sf Rambler with 500 sf loft - 1994 UBC	1998
New Two-story SFR w/attached garage	1998
New 24 x 60 - 1985 - Fleetwood	1998
New Rambler with attached garage	1998
New 1986 28 x 36 Fleetwood	1998
New 2 Story SFR with attached garage and daylighted - 1994 UBC	1998
New 3865 sf rambler w/574 sf garage and 1381 sf covered deck/porch	1998
New 2350 s.f. rambler with 2 car garage	1998
New Approved Basic #97-105227BP Plan #1024A Rambler Style SFR - 1994 UBC	1998
New 1998 Westwood by Slivercrest 26 x 60	1998
New 1997 27 x 66 Goldenwest	1998
New Two story SFR w/attached garage & bonus room above	1998
New 40x70, 1980 Cascade	1998
New 27x64 (1999) Palm Harbor #564	1998
New Rambler style SFR w/attached garage	1998
New 1464 sf rambler w/1464 sf finished basement and 453 sf garage	1998
New Rambler w/3 Car	1998
New 2 story SFR with attached garage	1998
New 2-Story SFR with attached garage.	1998
New Two-story SFR w/attached garage	1998
New 2 story sfr with 3 car garage	1998
New 2 story sfr with 2 car garage	1998
New 752 sf Apartment over 887 sf Garage	1998
New Two-story SFR w/attached garage	1998
New 27x44 1998 Palm Harbour	1998
New 26x40, 1994 Champion Sequoia	1998
New 27x 52 Golden West 1998	1998
New 2 Story w/2 Car	1998
New 1785 sf 2-story w/189 sf finished basement and 449 sf garage	1998
New Approved Basic #97-105227BP Plan #1024A Rambler Style SFR - 1994 UBC	1998
New 2 - Story SFR with attached garage - 1994 UBC	1998
New Approved Basic #98-102055-BP Two Story SFR w/attached garage. - 1994 UBC	1998
New SFR with Attached Garage	1998
New SFR w/unfinished basement - 1994 UBC	1998
New Approved Basic #96-108269BP Ramber Style SFR - 1994 UBC	1998
New SFR with Finished Basement	1998

Accessory Dwelling Units

Index # - File Name: 1.0022 - Single Family Dwellings Data\_Snohomish County.pdf

New	40x60 (1997) GoldenWest	1998
New	2 story SFR with attached garage - 1994 UBC	1998
New	28x42, 1994 Marlette	1998
New	26 x60 (1998) Fleetwood	1998
New	Two-story SFR w/attached garage	1998
New	3831 s.f. sfr with 2165 finished basement & attached 2937 s.f. garage	1998
New	28 x 66 - 1986 - Fleetwood Mobile Home	1998
New	2-Story SFR w/attached garage	1998
New	One-story duplex with attached garage	1998
New	14x60 1979 Skyline Mobile Home	1998
New	1987 Kenwood 28 x 56	1998
New	1998 Waverly Crest Triple Wide 40 x 66	1998
New	Approved Basic #97-103866BP Plan #1722 Rambler Style SFR - 1994 UBC	1998
New	Rambler style SFR with daylight basement and attached garage - 1994 UBC	1998
New	2- Story SFR with attached garage - 1994 UBC	1998
New	2-Story SFR w/attached Garage & Cov. porch.	1998
New	1998 Palm Harbour 40 x 52	1998
New	28x66, 1989 Skyline (Existing)	1998
New	One-story SFR w/attached garage	1998
New	One-story SFR w/attached garage	1998
New	2 Story w/3 Car	1998
New	40 x 48 1997 Golden Manor (Golden West)	1998
New	Rambler style SFR w/attached garage.	1998
New	Two-story SFR w/attached garage	1998
New	28 x 56 - 1986 Fleetwood-Greenhill Mobile Home	1998
New	14x56 (1994) Skyline/Meadow Ridge	1998
New	5160 sf 2-story w/2282 sf unfinished basement; w/965 sf garage; 279 sf carport; and 628 sf cov	1998
New	2887 sf rambler w/672 sf garage and 1228 sf covered deck/porch	1998
New	28x48 1997 Goldenwest	1998
New	1974 Homette 12 x 43	1998
New	One-story SFR w/attached garage	1998
New	14x70, 1976 Fleetwood	1998
New	1990 28 x 66 Marlette	1998
New	24 x 60 - 1977 Fleetwood Barrington - Mobile Home	1998
New	28 X 70 1981 Oakbrook	1998
New	27 x 40 Golden West	1998
New	Rambler with Attached Garage	1998
New	27x66, 1998 Golden West	1998
New	Two-story SFR w/attached garage	1998
New	27x51, 1998 Fleetwood (Celebration) Doublewide	1998
New	Two story SFR w/attached garage.	1998
New	2-Story SFR w/attached garage	1998
New	948 s.f. sfr with 444 s.f. unfinished basement & 2 car garage	1998
New	2 story SFR w/deck (Straw bale construction)	1998
New	1982 14 x 60 Sequoia-Champion	1998
New	1548 sf 2-story w/216 sf covered deck/porch	1998
New	1998 27 x 56 Palm Harbor	1998

Accessory Dwelling Units

Index # - File Name: 1.0022 - Single Family Dwellings Data\_Snohomish County.pdf

New	Two-story SFR w/attached garage	1998
New	68 x27 1998 Marlett	1998
New	Approved Basic #97-111516BP Plan: 1221 Duplex Two Story Duplex - 1994 UBC	1998
New	Approved Basic #97-111516BP Plan: 1221 Duplex Two Story Duplex - 1994 UBC	1998
New	Approved Basic #96-102793BP SFR w/finished or unfinished basement - 1994 UBC	1998
New	1978 Goldenwest 24 x 58	1998
New	1998 Golden West Executive Edition 52 x 27	1998
New	Pending Basic #98-116241BP 2067 sf 2-story w/592 sf garage and 465 sf covered deck/porch	1998
New	1998 Green Hill 4403C-DEN 40 x 27	1998
New	2620 sf 2-story w/550 sf garage and 240 sf covered deck/porch	1998
New	One-story SFR w/attached garage	1998
New	1998 27 x 56 Palm Harbor	1998
New	2 story w/basement & 3 Car	1998
New	2 story sfr	1998
New	Two-story SFR	1998
New	Approved Basic #95-108883BP Split Level SFR - 1994 UBC	1998
New	1431 sf rambler w/473 sf garage and 60 sf covered deck/porch	1998
New	1752 sf Duplex w/ 616 sf Garage	1998
New	1998 Fleetwood (28 x 60)	1998
New	2225 sf 2-story w/739 sf garage and 24 sf covered porch	1998
New	39 x 60 1998 Silvercrest Chalet (locked gate, tried to review 4/16/98, am calling for appointme	1998
New	2-Story SFR w/attached garage.	1998
New	Daylight Basement style SFR w/basement garage.	1998
New	1986 14 x 66 Sequoia Champion	1998
New	2 story garage with SFR on 2nd Floor	1998
New	2 Story with a 2 car. CLOSED W/O FINAL. SEE NEW PERMIT, 00-110565.	1998
New	Two Story SFR with Unfinished Basement and Attached Garage	1998
New	2880 s.f. rambler with 2 car garage	1998
New	40 X 66 Liberty 1998	1998
New	1993 14 x 52 Liberty. Work cont. on 00-109295.	1998
New	SFR	1998
New	28 x 55 1998 Fleetwood	1998
New	Two-story SFR w/attached garage	1998
New	1882 sf 2-story with 1081 sf unfinished basement	1998
New	1998 26 x 56 Marlette Pacifica	1998
New	New SFR	1998
New	2390 sf 2-stroy w/679 sf garage and 106 sf covered deck/porch	1998
New	2 Story w/2 Car	1998
New	Rambler style SFR w/attached garage	1998
New	Rambler style SFR w/attached garage.	1998
New	One-story SFR	1998
New	1782 sf sfr with 1685 unfinished basement w/2 car garage	1998
New	1898 s.f. sfr with 980 s.f. basement & 2 car garage	1998
New	12x50, 1970 Lamplighter	1998
New	Rambler style w/attached garage	1998
New	2 story SFR w attached garage	1998
New	2 Story house	1998



Accessory Dwelling Units

Index # - File Name: 1.0022 - Single Family Dwellings Data\_Snohomish County.pdf

New	2 Story w/bsmt		1998
New	2 Story w/Covered Deck		1998
New	Approved Basic #97-103863BP	Plan #1820 Rambler Style SFR - 1994 UBC	1998
New	Approved Basic #97-103863BP	Plan #1820 Rambler Style SFR - 1994 UBC	1998
New	SFR		1998
New	Rambler with attached garage		1998
New	Two-story SFR w/attached garage		1998
New	1999 28 x 56 Amercove		1998
New	SFR w/unfinished basement - 1994 UBC		1998
New	SFR w/unfinished basement - 1994 UBC		1998
New	Rambler Style SFR - 1994 UBC		1998
New	Approved Basic #96-101776BP	SFR w/finished basement - 1994 UBC	1998
New	1286 sframblor w/627 sf finished basement and 612 sf garage and 192 sf open deck		1998
New	Approved Basic #97-111955BP	Plan 2340 Two story SFR w/attached garage	1998
New	2596 s.f. Log Home		1998
New	Approved Basic #95-106587BP	0 LOT LINE STRUCTURE Two Story SFR (1994 UBC)	1998
New	Approved Basic #95-106586BP	0 LOT LINE STRUCTURE Two Story SFR (1994 UBC)	1998
New	Approved Basic #96-101920BP	0 LOT LINE STRUCTURE Two Story SFR - 1994 UBC	1998
New	Approved Basic #95-106587BP	0 LOT LINE STRUCTURE Two Story SFR (1994 UBC)	1998
New	Approved Basic #95-106587BP	0 LOT LINE STRUCTURE Two Story SFR (1994 UBC)	1998
New	Approved Basic #95-106583BP	0 LOT LINE STRUCTURE Two Story SFR (1994 UBC)	1998
New	Approved Basic #95-106583BP	0 LOT LINE STRUCTURE Two Story SFR (1994 UBC)	1998
New	Approved Basic #95-106587BP	0 LOT LINE STRUCTURE Two Story SFR (1994 UBC)	1998
New	Approved Basic #95-106587BP	0 LOT LINE STRUCTURE Two Story SFR (1994 UBC)	1998
New	Approved Basic #96-101920BP	0 LOT LINE STRUCTURE Two Story SFR - 1994 UBC	1998
New	Approved Basic #96-101911BP	0 LOT LINE STRUCTURE Two Story SFR - 1994 UBC	1998
New	Approved Basic #95-106587BP	0 LOT LINE STRUCTURE Two Story SFR (1994 UBC)	1998
New	Approved Basic #95-106587BP	0 LOT LINE STRUCTURE Two Story SFR (1994 UBC)	1998
New	Approved Basic #96-101920BP	0 LOT LINE STRUCTURE Two Story SFR - 1994 UBC	1998
New	Approved Basic #95-106586BP	0 LOT LINE STRUCTURE Two Story SFR (1994 UBC)	1998
New	Approved Basic #95-106587BP	0 LOT LINE STRUCTURE Two Story SFR (1994 UBC)	1998
New	Approved Basic #95-106587BP	0 LOT LINE STRUCTURE Two Story SFR (1994 UBC)	1998
New	Approved Basic #95-106586BP	0 LOT LINE STRUCTURE Two Story SFR (1994 UBC)	1998
New	Approved Basic #96-101920BP	0 LOT LINE STRUCTURE Two Story SFR - 1994 UBC	1998
New	Approved Basic #95-106587BP	0 LOT LINE STRUCTURE Two Story SFR (1994 UBC)	1998
New	Approved Basic #95-106587BP	0 LOT LINE STRUCTURE Two Story SFR (1994 UBC)	1998
New	Approved Basic #96-101911BP	0 LOT LINE STRUCTURE Two Story SFR - 1994 UBC	1998
New	Approved Basic #96-101920BP	0 LOT LINE STRUCTURE Two Story SFR - 1994 UBC	1998
New	Approved Basic #95-106587BP	0 LOT LINE STRUCTURE Two Story SFR (1994 UBC)	1998
New	2-Story SFR w/attached garage & covered porch.		1998
New	Two Story SFR - 1994 UBC		1998
New	Daylight Basement SFR		1998
New	13 5 x 60 plus 13 5 x 60 - 1999 - Oakwood		1998
New	New permit to complete sfr that was originally under expired permit #245307		1998
New	2 Story SFR with unfinished basement and attached garage and carport		1998
New	28 x 56 1998 Goldenwest		1998
New	1998 28 x 56 Goldenwest		1998

Accessory Dwelling Units

Index # - File Name: 1.0022 - Single Family Dwellings Data\_Snohomish County.pdf

New	40x60, 1998 Fleetwood Star		1998
New	2 story sfr with 2 car garage		1998
New	Two Story SFR with Attached Garage		1998
New	Two Story SFR with Attached Garage		1998
New	2 story sfr with 2 car garage. Finaled by Hal Reeves 12/22/99.		1998
New	2-Story SFR w/attached garage		1998
New	2 story sfr with 3 car garage & unheated sunroom		1998
New	28 X 66, 1998 Lake Point		1998
New	2-Story SFR w/attached garage & covered porch.		1998
New	2 story duplex with 2 car garages		1998
New	2 Story SFR with attached garage - 1994 UBC		1998
New	12 x 55 Mobile Home (1967)		1998
New	Rambler with attached garage - 1994 UBC		1998
New	Two Story SFR with Attached Garage		1998
New	SFR		1998
New	Two-story SFR w/attached garage		1998
New	27 x 52 - 1998 - Palm Harbor		1998
New	2-Story SFR w/attached Garages		1998
New	Rambler with attached garage - 1994 UBC		1998
New	2-Story SFR w/attached garage		1998
New	3136 sf 2-story with 1233 sf unfinished basement, 900 sf garage and 176 sf covered porch		1998
New	Rambler style SFR with attached 3 car garage		1998
New	Rambler style SFR with attached garage		1998
New	2-Story SFR w/attached garage		1998
New	2201 sf rambler w/980 sf garage and 96 sf covered deck/porch		1998
New	Two-story SFR w/attached garage		1998
New	Approved Basic #98-104920BP	Two Story SFR - 1994 UBC	1998
New	Two Story SFR - 1994 UBC	Plan #RH53/57	1998
New	Approved Basic #98-105418BP	Plan #RH35 Two Story SFR- 1994 U	1998
New	Two Story SFR - 1994 UBC	Plan RH55	1998
New	Two Story SFR - 1994 UBC	Plan #RH56 5/6/98 - Revisions to plans subn	1998
New	Approved Basic #98-105415BP	Plan #RH53/57 Two Story SFR - 199	1998
New	Two Story SFR - 1994 UBC	Plan RH58	1998
New	Two Story SFR - 1994 UBC		1998
New	Two Story SFR - 1994 UBC	Plan #RH 49	1998
New	Two Story SFR - 1994 UBC	Plan #RH16	1998
New	1466 Rambler with 2 car garage		1998
New	2 story SFR with attached garage and deck		1998
New	2-Story SFR w/attached garage		1998
New	Two-story SFR w/attached garage		1998
New	Three Story SFR		1998
New	2366sf rambler w/184 sf covered deck/porch		1998
New	2-Story SFR w/attached Garage.		1998
New	VIOLATION: MacQuarrie - please give copy of permit to DKN when issued Permit for existing 10		1998
New	2-Story SFR w/attached garage		1998
New	27 x 66 - 1998 Golden West		1998
New	2651 s.f. rambler with 3 car garage		1998

Accessory Dwelling Units

Index # - File Name: 1.0022 - Single Family Dwellings Data\_Snohomish County.pdf

New	One-story SFR w/attached garage		1998
New	2 Story Duplex w/Attached Garage		1998
New	1997 Ridgewood 27 x 66		1998
New	1984 NASHUA 14 X 56 Mobile Home (Guest House)		1998
New	27 x 66 Oakwood (1998)		1998
New	1998 Lake Pointe Medel #4563A 27 x 56		1998
New	Rambler Style SFR - 1994 UBC		1998
New	Rambler Style SFR - 1994 UBC		1998
New	2 Story w/3 Car		1998
New	Rambler w/ 2 Car		1998
New	2 story with 3 car garage		1998
New	2-Story SFR		1998
New	2-Story SFR w/attached garage		1998
New	40 X 60 , 1998 Marlette		1998
New	Two Story SFR - 1994 UBC		1998
New	2 story sfr with 2 car garage.		1998
New	Approved Basic 98-100558-BP	2 Story SFRw/attached garage	Bldrs Plan # 2478 B/2 1998
New	Approved Basic 98-100558-BP	2 Story SFRw/attached garage	Bldrs Plan # 2478 B/2 1998
New	One-story SFR w/attached garage		1998
New	2225 sf rambler w/420 sf garage and 60 sf covered porch		1998
New	Approved Basic #96-103338BP	Plan #2645 A/B	Two Story SFR -1994 UBC 1998
New	Two Story SFR - 1994		1998
New	2 Story w/3 Car		1998
New	2-Story SFR w/attached garage		1998
New	2-Story SFR w/attached garage.		1998
New	2330 sf 2-story w/648 sf gaarage and 108 sf covered deck/porch		1998
New	Approved Basic #98-100561BP	Bldrs Plan #2968	2-Story SFR w/attatched garage 1998
New	2 story SFR w/ attached 3 car garage		1998
New	2705 sf 2-story w/709 sf garage and 80 sf covered porch		1998
New	2 story SFR w/ attached 3 car garage		1998
New	Approved Basic #97-110322BP	Plan #2490 C/3	Two Story SFR - 1994 UBC 1998
New	Approved Basic #97-110762BP	Plan 2003	Two story SFR w/finished baserr 1998
New	2490 sf 2-story with 642 sf garage		1998
New	2190 sf 2-story w/528 sf garage and 90 sf covered porch		1998
New	2 story SFR		1998
New	2 story SFR w/ attached garage		1998
New	2 story SFR with attached garage ---1994 UBC		1998
New	Approved Basic #97-110625BP	2-Story SFR w/attached garage	Bldrs Plan #2510 1998
New	2 story SFR w/ attached 3 car Garage		1998
New	2 story SFR with attached garage ---1994 UBC		1998
New	One-story SFR w/attached garage		1998
New	Two-story SFR w/attached garage		1998
New	2-Story SFR - 1997 UBC		1998
New	1987 Fleetwood 24 x 60		1998
New	2 Story with attached garage and covered porch - 1997 UBC		1998
New	Two-story SFR w/attached garage		1998
New	SFR over garage		1998

Accessory Dwelling Units

Index # - File Name: 1.0022 - Single Family Dwellings Data\_Snohomish County.pdf

New	Approved Basic #97-110625BP	2-Story SFR w/attached garage	Bldrs Plan #2510	1998
New	26 8 x 56	1998 Fleetwood		1998
New	Two Story SFR - 1994			1998
New	Two Story SFR - 1994	UBC		1998
New	Approved Basic #97-109662BP	Plan #2141 Rambler with attached garage - 1994 U		1998
New	Approved Basic #97-109662BP	Plan #2141 Rambler with attached garage - 1994 U		1998
New	Split w/2 car			1998
New	Approved Basic #96-102793BP	OPTION: Approved SFR w/finished basement - 1994 UB		1998
New	Rambler Style SFR - 1994	UBC		1998
New	3474 sf 2-story w/779 sf garage and 49 sf unfinished basement			1998
New	24 x 64	1977 Hillcrest		1998
New	Split Entry Style SFR w/finished basement/garage			1998
New	14 X 60	Ridgewood 1979		1998
New	Two Story SFR - 1994	UBC		1998
New	Approved Basic #98-105460BP	SFR w/finished basement - 1994 UBC		1998
New	2096 sf rambler w/400 sf garage, 28 sf covered porch, and 112 sf open deck			1998
New	27 x 66 (1997)	Palm Harbor #1067		1998
New	27x60,	1998 Fleetwood		1998
New	561 sf	SFR		1998
New	Approved Basic #97-105339BP	Plan #1901 Two Story SFR - 1994 UBC		1998
New	New 1 story	SFR		1998
New	4412 sf 2-stroy w/965 sf unfinished basement and 546 sf garage and 204 sf covered porch			1998
New	1328 s.f. sfr with 1328 s.f. unfinished basement & 2 car garage			1998
New	1999 Ambercove	40 x 56		1998
New	2 Story SFR with attached garage - 1994	UBC		1998
New	2 Story SFR with attached garage - 1994	UBC		1998
New	Ref. 272158.			1998
New	2 story SFR w/ attached garage			1998
New	2 Story SFR w/att. Gar.			1998
New	Rambler with attached garage - 1997	UBC		1998
New	2 Story Log Home with finished basement and covered porch - 1994	UBC		1998
New	Approved Basic #98-105415BP	Plan #RH53/57 Two Story SFR - 199		1998
New	Two Story SFR - 1994	UBC	Plan #RH35	1998
New	Two Story SFR - 1994	UBC	Plan RH36	1998
New	Two Story SFR - 1994	UBC	Plan #37RH	1998
New	Approved Basic #98-105418BP	Plan #RH35 Two Story SFR- 1994 U		1998
New	Two Story SFR - 1994	UBC	Plan #RH39	1998
New	Two Story SFR w/finished lower floor - 1994	UBC		1998
New	Approved Basic #97-105807BP	Plan #SC3-B Two Story SFR - 1994 UBC		1998
New	Approved Basic #97-105807BP	Plan #SC3-B Two Story SFR - 1994 UBC		1998
New	2 Story Rambler with attached garage covered porch and unfinished basement	1994 UBC		1998
New	2 story sfr with 3 car garage			1998
New	2 story sfr with 2 car garage			1998
New	2682 sf 2-story w/763 sf garage and 225 sf covered deck/porch			1998
New	2-Story SFR w/attached garage			1998
New	2-Story SFR w/attached Garage.			1998
New	2-Story SFR w/attached Garage.			1998

Accessory Dwelling Units

Index # - File Name: 1.0022 - Single Family Dwellings Data\_Snohomish County.pdf

New	Two-story SFR w/attached garage		1998
New	2 Story SFR with attached 3-car garage - 1994 UBC		1998
New	Two-story SFR w/attached garage		1998
New	2-Story SFR w/attached garage.		1998
New	2 story sfr with 3 car garage		1998
New	2-Story SFR w/attached Garage		1998
New	Approved Basic #97 105806 Two-story SFR - 1994 UBC		1998
New	Two Story Duplex - 1994 UBC		1998
New	Two Story SFR with Attached Garage		1998
New	Approved Basic #96-110885BP	Plan 2209 C/E Two Story SFR - 1994 UBC	1998
New	Approved Basic #96-110883BP	Plan #2209 B/D Two Story SFR - 1994 UB	1998
New	Approved Basic #97-100338BP	Plan #2204 Two Story SFR - 1994 UBC	1998
New	Approved Basic #96-110885BP	Plan 2209 C/E Two Story SFR - 1994 UBC	1998
New	Approved Basic #97-100342BP	Plan #2207 Two Story SFR - 1994 UBC	1998
New	Approved Basic #97-101535BP	Plan #2301 w/den Two Story SFR - 1994 UBC	1998
New	Approved Basic #96-110885BP	Plan 2209 C/E Two Story SFR - 1994 UBC	1998
New	Approved Basic #96-110883BP	Plan #2209 B/D Two Story SFR - 1994 UB	1998
New	2 Story / 2 Car		1998
New	Two-story SFR w/attached garage		1998
New	Two Story SFR with Attached Garage		1998
New	Approved Basic #98-101971 BP	Plan #2330 C/3 Two Story SFR - 1994 UBC	1998
New	Approved Basic #98-101971BP	Plan #2330 C/3 Two Story SFR - 1994 UBC	1998
New	Two-story SFR w/attached garage		1998
New	Two Story SFR - 1994 UBC		1998
New	Two Story SFR - 1994 UBC		1998
New	Two Story SFR - 1994 UBC		1998
New	Approved Basic #97-108760BP	Plan #1150 Rambler Style - 1994 UBC	1998
New	Approved Basic #97-108760BP	Plan #1150 Rambler Style - 1994 UBC	1998
New	Approved Basic #97-108760BP	Plan #1150 Rambler Style - 1994 UBC	1998
New	Approved Basic #97-108760BP	Plan #1150 Rambler Style - 1994 UBC	1998
New	Approved Basic #97-108760BP	Plan #1150 Rambler Style - 1994 UBC	1998
New	Approved Basic #97-108760BP	Plan #1150 Rambler Style - 1994 UBC	1998
New	2-Story SFR with/attached garage		1998
New	Approved Basic #96-104979BP	Plan #1551 Rambler Style SFR - 1994 UBC	Optic 1998
New	Approved Basic #97-101148BP	Plan #1365 Rambler Style SFR - 1994 UBC	1998
New	Approved Basic #97-101148BP	Plan #1365 Rambler Style SFR - 1994 UBC	(; 1998
New	Approved Basic #97-105531BP	Plan #1729 Two Story SFR - 1994 UBC	1998
New	Approved Basic #97-105531BP	Plan #1729 Two Story SFR - 1994 UBC	1998
New	Approved Basic #97-105531BP	Plan #1729 Two Story SFR - 1994 UBC	1998
New	Approved Basic #96-104979BP	Plan #1551 Rambler Style SFR - 1994 UBC	Optic 1998
New	Approved Basic #97-101148BP	Plan #1365 Rambler Style SFR - 1994 UBC	1998
New	Approved Basic #97-101148BP	Plan #1365 Rambler Style SFR - 1994 UBC	1998
New	Approved Basic #98-102705BP	Plan 1360 Two Story SFR - 1994 UBC	1998
New	Approved Basic #98-102705BP	Two Story SFR - 1994 UBC	1998
New	Approved Basic #97-111522BP	1636 sf split w/480 sf garage	1998
New	Approved Basic #97-109196BP	Plan #1545 Two Story SFR - 1994 UBC	1998
New	1557 s.f. rambler w/2 car garage		1998

Accessory Dwelling Units

Index # - File Name: 1.0022 - Single Family Dwellings Data\_Snohomish County.pdf

New	Approved Basic #98-102705BP	Two Story SFR - 1994 UBC	1998
New	Two Story SFR with Attached Garage		1998
New	42x66 (1998) Triplewide Silvercrest		1998
New	28x56, 1997 Palm Harbor		1998
New	2 Story w/ 2 car		1998
New	Two Story SFR - 1994 UBC		1998
New	Rambler style SFR with attached garage - 1994 UBC		1998
New	Two-story SFR w/basement & attached garage		1998
New	One-story SFR		1998
New	Approved Basic #97-103606BP	Plan #1232 Two Story SFR - 1994 UBC	1998
New	Approved Basic #97-103604BP	Plan #1362 Rambler Style SFR - 1994 UBC	1998
New	Approved Basic #98-100925BP	Plan #1610 Two Story SFR - 1994 UBC	1998
New	Approved Basic #97-103607BP	Plan #1485 Two Story SFR - 1994 UBC	1998
New	Approved Basic #98-100925BP	Plan #1610 Two Story SFR - 1994 UBC	1998
New	Approved Basic #97-100843BP	Plan 1309 Two Story SFR - 1994 UBC	1998
New	Approved Basic #98-116510BP	Plan: 1610 C/2 Two-story SFR - 1994 UBC	1998
New	Approved Basic #98-116510BP	Plan: 1610 C/2 Two-story SFR - 1994 UBC	1998
New	Approved Basic #98-115607BP	Plan: 1441T A-B/2 SFR w/finished basement - 1994 UBC	1998
New	Approved Basic #98-116510BP	Plan: 1610 C/2 Two-story SFR - 1994 UBC	1998
New	Approved Basic #98-100925BP	Plan #1610 Two Story SFR - 1994 UBC	1998
New	Approved Basic #97-103610BP	Plan #1441 SFR w/finished basement - 1994 UBC	1998
New	Approved Basic #98-100925BP	Plan #1610 Two Story SFR - 1994 UBC	1998
New	Two Story SFR w/attached garage	1997 UBC 1997-WSEC Bldrs. Plan #1610.	1998
New	Approved Basic #98-100925BP	Plan #1610 Two Story SFR - 1994 UBC	1998
New	Tri Level SFR - 1997 UBC	Plan #1441	1998
New	Approved Basic #97-103613BP	Plan #1361 Two Story SFR - 1994 UBC	1998
New	Approved Basic #97-103610BP	Plan #1441 SFR w/finished basement - 1994 UBC	1998
New	Two Story SFR - 1997 UBC	Plan #1361 1997-UBC 1997-WS	1998
New	48 x 49 1997 Amber Cove		1998
New	Approved Basic #97-105227BP	Plan #1024A Rambler Style SFR - 1994 UBC	1998
New	Two Story SFR - 1994 UBC	Plan: 1610	1998
New	Approved Basic #97-103607BP	Plan #1485 Two Story SFR - 1994 UBC	1998
New	Approved Basic #97-103613BP	Plan #1361 Two Story SFR - 1994 UBC	1998
New	Approved Basic #98-110007BP	Builders Plan #1588 2-Story SFR w/attached garage - 1994 UBC	1998
New	Approved Basic #98-100925BP	Plan #1610 Two Story SFR - 1994 UBC	1998
New	Approved Basic #97-103613BP	Plan #1361 Two Story SFR - 1994 UBC	1998
New	Approved Basic #97-103610BP	Plan #1441 SFR w/finished basement - 1994 UBC	1998
New	Approved Basic #98-100925BP	Plan #1610 Two Story SFR - 1994 UBC	1998
New	Approved Basic #98-100925BP	Plan #1610 Two Story SFR - 1994 UBC	1998
New	Approved Basic #98-100925BP	Plan #1610 Two Story SFR - 1994 UBC	1998
New	Approved Basic #97-103610BP	Plan #1441 SFR w/finished basement - 1994 UBC	1998
New	Approved Basic #98-100925BP	Plan #1610 Two Story SFR - 1994 UBC	1998
New	Approved Basic #97-103610BP	Plan #1441 SFR w/finished basement - 1994 UBC	1998
New	Approved Basic #97-103610BP	Plan #1441 SFR w/finished basement - 1994 UBC	1998
New	Two Story SFR - 1997 UBC		1998
New	Approved Basic #98-110007BP	Builders Plan #1588 2-Story SFR w/attached garage - 1994 UBC	1998
New	Approved Basic #98-115607BP	Plan: 1441T A-B/2 SFR w/finished basement - 1994 UBC	1998

Accessory Dwelling Units

Index # - File Name: 1.0022 - Single Family Dwellings Data\_Snohomish County.pdf

New	Approved Basic #98-110007BP	Builders Plan #1588	2-Story SFR w/attac	1998
New	Approved Basic #98-110007BP	Builders Plan #1588	2-Story SFR w/attac	1998
New	Approved Basic #98-100925BP	Plan #1610	Two Story SFR - 1994 UBC	1998
New	Approved Basic #97-103604BP	Plan #1362	Rambler Style SFR - 1994 UBC	1998
New	Approved Basic #97-103610BP	Plan #1441	SFR w/finished basement - 1994	1998
New	Approved Basic #98-100925BP	Plan #1610	Two Story SFR - 1994 UBC	1998
New	Approved Basic #97-103604BP	Plan #1362	Rambler Style SFR - 1994 UBC	1998
New	Approved Basic #97-103613BP	Plan #1361	Two Story SFR - 1994 UBC	1998
New	Approved Basic #97-103613BP	Plan #1361	Two Story SFR - 1994 UBC	1998
New	Approved Basic #97-103613BP	Plan #1361	Two Story SFR - 1994 UBC	1998
New	1361 s.f. rambler with 600 s.f carport			1998
New	Approved Basic #97-105227BP	Plan #1024A	Rambler Style SFR - 1994 UBC	1998
New	2680 s.f. rambler with 780 s.f. 2 car garage			1998
New	Rambler style SFR w/attached garage			1998
New	Rambler with Attached Garage			1998
New	Daylight Basement style SFR.			1998
New	2662 sf 2-story w/528 sf garage and 228 sf covered porch			1998
New	Two-story SFR w/attached garage			1998
New	Duplex w/attached garage			1998
New	Approved Basic #97-109587-BP	Plan #1675	Rambler Style SFR - 1994 UBC	1998
New	Tri-Level style SFR w/attached garage			1998
New	1998 Marlette 26 x 60			1998
New	28x66, 1998 Fleetwood. WORK CONT. ON 01-100621.			1998
New	1553 sf rambler with 2 car garage			1998
New	Two-story SFR w/attached garage			1998
New	2 story sfr with unfinished basement			1998
New	1998 Palm Harbor (56 x 27)			1998
New	Approved Basic #98-100659BP	1250 s.f. rambler with 2 car garage		1998
New	Approved Basic #97-111955-BP	Plan 2340	Two story SFR w,	1998
New	14 x 52 (1995) Nashua			1998
New	2 story SFRw/ 2 car garage			1998
New	Approved Basic #97-103863BP	Plan #1820	Rambler Style SFR - 1994 UBC	1998
New	2264 sf 2-story w/714 sf garage and 108 sf covered deck/porch			1998
New	One-story SFR w/attached garage			1998
New	Two Story SFR with Unfinished Basement and Attached Garage			1998
New	Two Story SFR with Attached Garage			1998
New	2 story SFR w/ attached garage			1998
New	10 x 55 (1969) York			1998
New	Approved Basic #97-103863BP	Plan #1820	Rambler Style SFR - 1994 UBC	1998
New	Approved Basic #97-103863BP	Plan #1820	Rambler Style SFR - 1994 UBC	1998
New	Approved Basic #97-103866BP	Plan #1722	Rambler Style SFR - 1994 UBC	1998
New	2 Story w/2 Car			1998
New	Two-story SFR w/attached garage			1998
New	Approved Basic #97-103866BP	Plan #1722	Rambler Style SFR - 1994 UBC	1998
New	SFR w/finished basement - 1994 UBC	Plan: 2035		1998
New	Approved Basic #97-103863BP	Plan #1820	Rambler Style SFR - 1994 UBC	1998
New	2-Story SFR w/Breezeway to attached garage.			1998

Accessory Dwelling Units

Index # - File Name: 1.0022 - Single Family Dwellings Data\_Snohomish County.pdf

New	Approved Basic #97-108427BP	Plan #2136	Two Story SFR - 1994 UBC	1998
New	Rambler with Attached Garage			1998
New	Approved Basic #97-103863BP	Plan #1820	Rambler Style SFR - 1994 UBC	1998
New	Approved Basic #98-110213BP		Plan: #1333 Two Story Duplex - 1997	1998
New	DO NOT PROCEED. NSF CHECK 11/4/98. QUESTIONS CALL KATIE X2226.		Rambler with attached	1998
New	2-Story SFR w/attached garage			1998
New	28x60, 1998 Skyline			1998
New	Rambler style SFR w/attached carport.			1998
New	Two-story SFR w/attached garage			1998
New	2 Story w/unfin bsmt bonus room & 3 car garage			1998
New	2 Story w/2 Car			1998
New	2- Story SFR with attached garage - 1994 UBC			1998
New	3662 sf 2-story w/1036 sf garage and 390 sf covered deck/porch			1998
New	2 story SFR with attached garage --1994 UBC---			1998
New	2474 sf 2-stroy w/518 sf garage and 56 sf covered deck/porch			1998
New	2 story SFR with attached garage - 1994 UBC.			1998
New	Day-light Basement Style SFR w/attached garage.			1998
New	2277 sf 2-story w/704 sf garage and 224 sf covered deck/porch			1998
New	28x60; 1996 Marlette			1998
New	Approved Basic #97-111955BP	Plan 2340	Two story SFR w/attached garage	1998
New	Approved Basic #96-101623BP		Two Story SFR - 1994 UBC	1998
New	1629 sf rambler			1998
New	2 story SFR w/ 3 car garage			1998
New	Approved Basic #98-104140BP		Plan # Unit B- Duplex Two Story Duplex	1998
New	Approved Basic #98-104140BP		Plan # Unit B- Duplex Two Story Duplex	1998
New	Approved Basic #98-104142BP	Plan # Unit C - Duplex	Two Story Duplex - 1994 UBC	1998
New	Approved Basic #98-104140BP		Plan # Unit B- Duplex Two Story Duplex	1998
New	Approved Basic #98-104140BP		Plan # Unit B- Duplex Two Story Duplex	1998
New	Approved Basic #98-104140BP		Plan # Unit B- Duplex Two Story Duplex	1998
New	Approved Basic #98-104140BP		Plan # Unit B- Duplex Two Story Duplex	1998
New	Approved Basic #96-104140BP		Plan # B-unit Duplex Two Story Duplex	1998
New	Approved Basic #98-104142BP		Plan # Unit C - duplex Two Story Duplex	1998
New	Approved Basic #98-104140BP		Plan # Unit B- Duplex Two Story Duplex	1998
New	Approved Basic #98-104140BP		Plan # Unit B- Duplex Two Story Duplex	1998
New	Approved Basic #98-104140BP		Plan # Unit B- Duplex Two Story Duplex	1998
New	28x48 (1984) Fleetwood			1998
New	28 x 66 1996 Fleetwood Greenhill			1998
New	2 Story SFR with attached garage- 1994 UBC			1998
New	Approved Basic #98-108660BP		Rambler with attached garage - 1997 UBC	1998
New	2-Story SFR w/attached Garage.			1998
New	2 story SFR with attached garage and covered porch			1998
New	1997 Pacifica 27 x 56			1998
New	Daylight Basement Rambler style SFR w/attached garage.			1998
New	1287 sf 2-story w/594 sf garage			1998
New	1816 sf 2-story with 576 sf garage and 24 sf covered deck/porch			1998
New	2 story SFR with attached garage and covered porch			1998
New	SFR with Attached Garage and Basement			1998



Accessory Dwelling Units

Index # - File Name: 1.0022 - Single Family Dwellings Data\_Snohomish County.pdf

New	3392-Sq. Ft. Duplex w/attached garages	1998
New	2203 sf 2-story w/300 sf covered deck/porch	1998
New	2 Story w/ 3 Car	1998
New	Approved Basic #96-100375BP Plan #1502 Rambler Style SFR - 1994 UBC	1998
New	Two-story SFR w/loft, unfin bsmt, attached garage	1998
New	Two-story SFR w/attached garage	1998
New	2 story sfr with 3 car garage	1998
New	Two-story SFR w/attached garage	1998
New	Two Story SFR with Attached Garage	1998
New	Two Story SFR with Attached Garage	1998
New	Double Wide mobile home	1998
New	Two-story SFR w/attached garage	1998
New	2 story with attached garage	1998
New	Two-story SFR w/attached garage	1998
New	Two story SFR w/attached garage	1998
New	28x52 (1998) #5201, #5202B, #5203A	1998
New	1550 s.f. rambler with 2 car garage	1998
New	2-Story SFR w/attached garage	1998
New	Rambler Style SFR - 1994 UBC	1998
New	Approved Basic #96-101623BP Two Story SFR - 1994 UBC	1998
New	2 story sfr with 3 car garage	1998
New	28x66 1998 Fleetwood	1998
New	Two-story SFR w/attached garage	1998
New	One-story SFR w/attached garage	1998
New	Two-story SFR w/unfin basement & attached garage	1998
New	Two-story SFR w/attached garage	1998
New	Approved Basic #97-108103BP Builders # 1901 Two Story SFR - 1994 UBC	1998
New	2 story w/2 car	1998
New	Rambler style SFR with attached garage	1998
New	2 story SFR with attached garage -- 1994 UBC	1998
New	2 story SFR with attached garage --- 1994 UBC	1998
New	Two-story SFR w/attached garage	1998
New	1840 s.f. sfr with unfinished basement & 2 car garage	1998
New	Two-story SFR w/attached garage	1998
New	Two-story SFR w/attached garage	1998
New	2-Story SFR over finished basement w/attached garage.	1998
New	Two Story SFR with Attached Garage	1998
New	Rambler w/3 Car.	1998
New	12 x 48 1972 Lamplighter	1998
New	2 story w attached gargage w second story storage, covrd porches, unheated plant room	1998
New	2 story w/2 car	1998
New	Two Story SFR with Attached Garage	1998
New	2 story sfr with 2 car garage	1998
New	Rambler with unfinished daylighted basement and attached garage - 1997 UBC	1998
New	28x66, 1998 Champion	1998
New	Mobile Home	1998
New	1996 Fleetwood doublewide	1998

Accessory Dwelling Units

Index # - File Name: 1.0022 - Single Family Dwellings Data\_Snohomish County.pdf

New	26 8 x 56 Fleetwood (1999)	1998
New	2 story with attached garage	1998
New	Two-story SFR w/attached garage	1998
New	2 Story SFR with daylighted and attached garage - 1994 UBC	1998
New	2 story sfr with 3 car garage	1998
New	2 Story w/3 car	1998
New	2 story sfr with 3 car garage	1998
New	3922 sf 2-story w/1722 sf garage and 111 sf covered deck/porch	1998
New	2-Story SFR w/attached garage.	1998
New	2 story SFR w/ attached garage	1998
New	Rambler w/3 car	1998
New	24 x 60 1977 Sahara	1998
New	2 story sfr with 2 car garage	1998
New	2 story sfr with 2 car garage	1998
New	40x61, 1998 Buckingham	1998
New	2 Story duplex w/two 2-car garages	1998
New	Two Story SFR with Unfinished Basement and Attached Garage	1998
New	2 story SFR with attached garage	1998
New	2-Story SFR w/attached garage.	1998
New	1998 Palm Harbor T3368 40 x 68	1998
New	1 story sfr rambler w/attached garage	1998
New	2-Story SFR w/unfinished Daylight basement & garage	1998
New	SFR	1998
New	3078 sf 2-story Duplex w/916 sf garage and 72 sf covered porch	1998
New	2438 sf 2-story w/1176 sf unfinished basement, and 922 sf garaage and 960 sf covered deck/po	1998
New	2-story SFR with Unfin Basement & attached Garage 2. Arach. of record (lat & vert) Richard Y S	1998
New	28 X 66 Fleetwood 1999	1998
New	Two Story SFR	1999
New	1984 40 x 24 Citation	1999
New	2 Story	1999
New	66x26 (1999) Liberty	1999
New	28x44 (1996) Fleetwood	1999
New	2 Story w/3 Car	1999
New	2 story sfr w/3 car garage	1999
New	2-story SFR w/attached 3-car garage.....1997 UBC	1999
New	Two-story SFR w/attached garage	1999
New	2 Story SFR w/attached 3 Car Garage & 200sf Sunroom	1999
New	2-story SFR w/attached 3-car garage.....1997 UBC	1999
New	27x56, 1999 Palm Harbor	1999
New	1359 sf rambler w/425 sf garage and 156 sf covered deck/porch	1999
New	40 x 66 1999 Oakwood	1999
New	Two-story SFR w/finished basement & attached garage	1999
New	3653 sf 2-story w/831 sf garage and 40 sf covered deck/porch	1999
New	2 story sfr w/3 car garage	1999
New	1716 sf main floor w/1677 unfinished basement; 579 sf garage and 162 sf covered deck/porch	1999
New	14x70 1985 Champion	1999
New	2595 sf 2-story w/858 sf garage, 28 sf covered porch and 104 sf open deck	1999

Accessory Dwelling Units

Index # - File Name: 1.0022 - Single Family Dwellings Data\_Snohomish County.pdf

New	two story SFR with attached three car garage.		1999
New	Daylite Rambler with a 2 car	3-18-97 Applicant brought in approved set of contractor s plans fi	1999
New	26.7 x 48	1999 First Edition Double Wide Mobile Home to be used as Caretaker s Quarter s fo	1999
New	2-story SFR w/unfinished daylight basement & attached 2-car garage....	1997 UBC	1999
New	Two Story SFR with Attached Garage		1999
New	Rambler with attached garage and covered entry -	1997 UBC	1999
New	Two-story SFR w/attached garage		1999
New	Approved Basic 99-101299BP	Mid-Entry With 2 Car -	1997 UBC
New	Approved Basic 99-101299BP	Mid-Entry With 2 Car -	1997 UBC
New	7603 sf 2-story w/1374 sf garage, 272 sf unfinished basement, 428 sf covered deck/porch and 4		1999
New	1434 s.f. rambler w/2 car garage		1999
New	Approved Basic #99-110424 BP	Rambler Style SFR -	1997 UBC
New	1999 42 x 66	Silvercrest	1999
New	1999 Oakwood	28 x 55	1999
New	Daylight basement style SFR w/attached garage.		1999
New	2-story SFR w/attached 2-car garage....	1997 UBC	1999
New	Two Story SFR -	1997 UBC	1999
		Plan: K2745B	
New	Two Story SFR -	1997 UBC	1999
		Plan #K2925	
New	2-Story SFR w/attached garage.		1999
New	2 story Log House		1999
New	1509 s.f. rambler with 2 car garage		1999
New	2 Story w/Covered Porch		1999
New	2 story sfr with 3 car garage		1999
New	2 story SFR with attached garage -	1997 UBC	1999
New	2 Story SFR with attached garage and covered entry -	1997 UBC	1999
New	Approved Basic #98-104142BP		1999
		Plan # Unit C - Duplex	Two Story Di
New	50 x 70 (1998)	Fleetwood	1999
New	70 x 30 (1987)	Marlette Pacifica	1999
New	26 x 44 -	1998 - Liberty	1999
New	Installation of 1974 14 x 60	New Moon by Redman	1999
New	1144 sf 2-story w/308 sf garage		1999
New	2 story sfr with 3 car garage		1999
New	Two Story SFR with Finished Basement and Attached Garage		1999
New	Rambler style SFR w/attached garage & covered porch.		1999
New	Rambler style SFR w/attached 3-car garage.		1999
New	1999 Triple Play	40 x 56	1999
New	2700sf two story, SFR		1999
New	2 Story w/finished basement & 3 car		1999
New	2-story SFR w/daylight basement and attached 2-car garage....	1997 UBC	1999
New	2 story sfr with 3 car garage		1999
New	28 x 64 -	1999 - Palm Harbor Mobile Home.	1999
New	New two story 2255sf SFR with attached two car garage.		1999
New	New 2356sf, two story SFR with attached two car garage.		1999
New	2-Story SFR w/attached garage.		1999
New	Split level with finished basement & 2 car garage		1999
New	1836 sf rambler w/1836 sf unfinished basement and 63 sf covered porch		1999
New	27 x 66 -	1999 - Oakwood	1999

Accessory Dwelling Units

Index # - File Name: 1.0022 - Single Family Dwellings Data\_Snohomish County.pdf

New	New one story with loft.	1999
New	A-frame SFR w/unfinished basement & a main floor with loft over kitchen....1997 UBC PLANS A	1999
New	2-Story SFR w/attached garage	1999
New	2-Story SFR w/attached Garage. THIS PERMIT SHOULD NOT HAVE BEEN RENEWED - FINALED OI	1999
New	3626 sf 2-story	1999
New	2607 sf 2-story w/809 sf garage, 120 sf covered deck/porch, and 80 sf open deck	1999
New	Rambler Style SFR with attached garage	1999
New	Two Story SFR with Attached Garage	1999
New	2734 sf DUPLEX w/900 sf garage and 256 sf covered deck/porch	1999
New	2-story SFR w/attached 3-car garage.....1997 UBC	1999
New	27 x 52 - 1998 - Silverwood SV-52	1999
New	2 story SFR with attached garage and covered porch	1999
New	2 Story w/3 car	1999
New	2112 s.f. rambler with 2 car garage	1999
New	28x46 (1998) Fleetwood	1999
New	26x42 (1996) Fleetwood	1999
New	Rambler w/ 2 car	1999
New	Two Story Duplex - 1997 UBC	1999
New	12x35, 1995 Cavco	1999
New	Two-story SFR w/attached garage	1999
New	One-story SFR w/attached garage	1999
New	Rambler with Attached Garage	1999
New	One story SFR w/attached garage	1999
New	Two-story SFR w/attached garage	1999
New	56x40, 1997 Northstar	1999
New	2-story SFR w/attached 3-car garage....1997 UBC	1999
New	One-story SFR w/attached garage	1999
New	2-story SFR w/attached 3-car garage & bonus room over the garage....1997 UBC	1999
New	3754 sf 2-story w/1290 sf unfinished basement and 680 sf garage and 50 sf covered porch	1999
New	2222 sf rambler w/496 sf covered deck/porch and 256 sf open deck	1999
New	Two-story SFR w/attached garage	1999
New	2 story SFR with semifinished basement and attached garage	1999
New	1 story Rambler w/attached 3 car garage	1999
New	Rambler w/2 Car	1999
New	28x66 (1999) Redmond	1999
New	New 2790sf two story SFR with attached two car garage - 1997 UBC	1999
New	1999 26.5 x 66 Ridgewood/GlenOaks	1999
New	Rambler w/daylight basement.....1997 UBC	1999
New	SFR	1999
New	2 story DUPLEX w/attached garages	1999
New	Approved Basic #95-110373BP Tri-Level SFR - 1994 UBC	1999
New	Two Story SFR - 1997 UBC	1999
New	28 x 48 - 1999 - Marlette	1999
New	New 1999, 27 x 56ft Countryside Oak	1999
New	1250 s.f. rambler	1999
New	One-story SFR w/attached garage	1999
New	Approved Basic #99-112836 BP	1999

Plan: #2461 Two Story SFR - 1997

Accessory Dwelling Units

Index # - File Name: 1.0022 - Single Family Dwellings Data\_Snohomish County.pdf

New	2-story SFR w/unfinished daylight basement.....1997 UBC		1999
New	2-story SFR w/full unfinished basement.....1997 UBC		1999
New	2615 sf 2-story w/759 sf unfinished basement, 633 sf garage and 64 sf covered porch		1999
New	2-Story SFR w/attached garage.		1999
New	2-story SFR w/unfinished basement & attached 2-car garage.....1997 UBC	NEW CELL PHONE # 4	1999
New	1708sf single story SFR with attached two car garage.		1999
New	1958 sf 2-story w/1061 sf unfinished basement and 128 sf covered porch and 640 sf open deck		1999
New	Existing 1979 Kentwood, 14 x 60		1999
New	Approved Basic #99-112836 BP	Plan: #2461 Two Story SFR - 199	1999
New	Approved Basic #99-112836 BP	Plan: #2461 Two Story SFR - 1997	1999
New	Two-story SFR w/attached garage		1999
New	Approved Basic 99-101299BP	Plan: #10 Mid-Entry With 2 Car - 1997 UI	1999
New	28 x 66 - 1999 - Marlette.		1999
New	*****REFERENCE PREVIOUS PERMIT #272058*****		1999
New	2 story SFR with attaced garage - 1997 UBC		1999
New	1999 27 x 48 Fleetwood		1999
New	Two-story SFR w/attached garage		1999
New	Two-story SFR w/attached garage		1999
New	2-story SFR w/unfinished basement & attached 3-car garage....1997 UBC		1999
New	2-story SFR w/unfinished basement & attached 3-car garage...1997 UBC		1999
New	SFR w/unfinished basement - 1997 UBC. Finaled on renewed permit.		1999
New	Approved Basic #95-108526BP SFR w/unfinished basement 1994 UBC		1999
New	SFR w/unfinished basement - 1997 UBC		1999
New	SFR w/unfinished basement - 1997 UBC		1999
New	SFR w/unfinished basement - 1997 UBC		1999
New	SFR w/unfinished basement - 1997 UBC		1999
New	SFR w/unfinished basement - 1997 UBC		1999
New	SFR w/unfinished basement - 1997 UBC		1999
New	SFR w/unfinished basement - 1997 UBC		1999
New	SFR w/unfinished basement - 1997 UBC		1999
New	2 story SFR with attached garage - 1997 UBC		1999
New	One-story SFR w/unfin bsmt & attached garage		1999
New	Rambler w/3 Car		1999
New	Two Story SFR with Attached Garage and Semi Finished Basement		1999
New	Split Level Style SFR with attached garage		1999
New	Rambler with Semi-Finished basement and attached garage - 1997 UBC		1999
New	42x66 (1998) Villa West, VW6600IK. FINAL INSPECTTION DONE UNDER PERMIT 04-116486.		1999
New	2 Story w/2 Car		1999
New	2 Story SFR w/ attached 2 car garage		1999
New	2159 sf 2-stroy w/540 sf garage and 400 sf covered deck/porch and 477 sf open deck		1999
New	2384 s.f. rambler w/3 car garage		1999
New	14x56 (1976) Gibraltor		1999
New	New 2 story SFR with attached garage.		1999
New	2 story sfr with 3 car garage		1999
New	SFR Rambler w/ attached garage		1999
New	Approved Basic #98-150745BP	Plan: Amanda Rambler style SFR wit	1999
New	1526 s.f. sfr with 2 car garage		1999

Accessory Dwelling Units

Index # - File Name: 1.0022 - Single Family Dwellings Data\_Snohomish County.pdf

New	Daylight basement style SFR w/semi-finished basement & attached garage.	1999
New	ALL INSPECTIONS WERE COMPLETED AS PER BUILDING CODES. PERMIT WAS NOT SIGNED OFF (	1999
New	Rambler with attached garage - 1997 UBC	1999
New	2 Story w/3 Car	1999
New	Rambler Style SFR w/attached garage.	1999
New	2672 sf rambler w/772 sf garage and 48 sf covered deck/porch	1999
New	2219 sf 2-story w/916 sf garage and 48 sf covered deck/porch	1999
New	2-story SFR w/attached 3-car side entry (Opt. II) garage.....1997 UBC	1999
New	2 story sfr with 3 car garage	1999
New	Two-story SFR w/attached garage	1999
New	28 x 64 1988 Fleetwood	1999
New	Rambler w/3 Car	1999
New	2064 sf 2-story w/630 sf garage	1999
New	2 story SFR with daylighted and attached garage - 1994 UBC	1999
New	2208 sf sfr with 188 s.f. unfinished basement & 2 car garage & 2 car carport	1999
New	2 Story w/2 Car	1999
New	26 X 46 2 Story w/2 Car	1999
New	One-story SFR w/unfinished basement & attached garage	1999
New	1968 Brook Dbl-Wide 20 x 40.	1999
New	2-Story SFR w/attached garage	1999
New	1987 24 x 48 Greenbrier (tan colored)	1999
New	2 story sfr	1999
New	3000 sq ft Rambler w/attached 3-car garage.....1997 UBC	1999
New	2639 sf 2-story w/506 sf garage, and 340 sf covered deck/porch	1999
New	2-story SFR w/attached 2-car garage.....1997 UBC	1999
New	Rambler Style SFR w/attached garage.	1999
New	2-Story SFR w/attached garage.	1999
New	2-story SFR w/attached 3-car garage....1997 UBC	1999
New	24 x 64 - 1978 Port Royal	1999
New	Rambler w/finished bsmt & bonus room & 3 car	1999
New	1999 Golden West 24 x 32	1999
New	2 Story w/ 3 Car	1999
New	Two-story SFR w/unfin basement & basement garages	1999
New	Two Story SFR with Attached Garage	1999
New	2-Story SFR w/attached garage	1999
New	2 Story w/ Semi Finished Basement & 2 Car	1999
New	2 story SFR with attached garage	1999
New	Rambler style SFR with attached garage and covered porch	1999
New	2-story SFR w/attached 3-car garage.....1997 UBC	1999
New	2 story w/ 3 car	1999
New	3093 sf rambler w/2016 sf finished basement and 192 sf covered porch	1999
New	4039 sf 2-story w/1015 sf garage and 48 sf covered deck/porch and 84 sf open deck	1999
New	2 Story with attached garage - 1997 UBC	1999
New	SFR with attached garage and daylighted - 1997 UBC	1999
New	2 story SFR with attached garage	1999
New	1983 24 x 32 Fleetwood	1999
New	28 x 60 1999 Redmond	1999

Accessory Dwelling Units

Index # - File Name: 1.0022 - Single Family Dwellings Data\_Snohomish County.pdf

New	Rambler with Attached Garage with Second Story storage Room	1999
New	768 sf Accessory Apartment w/204 sf open deck	1999
New	2-story SFR w/basement and attached 2-car garage.....1997 UBC	1999
New	12 X 60 1969 Marlette	1999
New	1453 sf rambler w/469 sf garage	1999
New	Split level SFR with attached garage	1999
New	26x66 (1995), Champion; Park River	1999
New	2 story SFR -- 1997 UBC	1999
New	1999 27 x 56 Marlette	1999
New	Rambler w/3 Car	1999
New	2-Story SFR	1999
New	Ramber SFR.....1997 UBC	1999
New	SFR with finished Basement and Attached Garage	1999
New	2 Story SFR - 1997 UBC	1999
New	27 x 56 1998 Oak Grover	1999
New	2 story SFR with attached garage/shop and covered porch	1999
New	27x56 1997 Golden West	1999
New	2-story SFR w/attached 2-car garage....1997 UBC	1999
New	40 x 66 1999 Ambercove	1999
New	Conversion of existing Mobile Home to Guest House	1999
New	27 x 48 Palm Harbor	1999
New	24 x 60 - 1977 Fleetwood Barrington - Mobile Home	1999
New	Approved Basic #99-111975 BP	Plan: 1533 Two Story SFR - 199
New	24 x 56 - 1980 - Sequoia	1999
New	New 1905sf single story SFR with attached two car garage	1999
New	1999 Skyline Greenbrier 6300 27 x 52	1999
New	Approved Basic #98-150644BP	Builders Plan: Charlene 2 story sfr with 2 ca
New	Two-story SFR	1999
New	1999 27 x 49 Palm Harbor	1999
New	27 x 40 1999 Goldenwest MH	1999
New	2000 40 x 56 Amercove	1999
New	2500 sf 2-story w/600sf garage and 200 sf covered deck/porch and 120sf open deck	1999
New	28 x 40 1985 Sunwood	1999
New	28 x 56 Fleetwood (1984)	1999
New	1976 14 x 60 Fleetwood	1999
New	40 x 52 - 1999 - Silvercrest	1999
New	1432 sq ft Rambler SFR.....1997 UBC	1999
New	2 story sfr with 2 car garage	1999
New	1985 Fleetwood (Barrington) 28 x 48	1999
New	New 1700sf SFR with attached garage - 1997 UBC	1999
New	2 story sfr	1999
New	2-story SFR w/unfinished basement.....1997 UBC	1999
New	Rambler Style SFR w/attached garage	1999
New	1288 sf rambler w/624 sf garage and 400 sf covered porches	1999
New	66 X 27 Golden West 1999	1999
New	SFR with daylight basement and attached garage	1999
New	Two-story SFR w/attached garage	1999

Accessory Dwelling Units

Index # - File Name: 1.0022 - Single Family Dwellings Data\_Snohomish County.pdf

New	Reversed Expired status to allow final inspection per Alan Husby	Expired w/o County approval t	1999
New	One-story SFR - 1997 UBC		1999
New	New 2096sf two story SFR with attached two car garage.		1999
New	2691 sf 2-story w/1490 sf unfinished basement and 324 sf covered deck/porch		1999
New	42 x 52 Marlette (1999)		1999
New	New 1045sf rambler with attached two car garage.		1999
New	1981 Fleetwood/Sandlewood 28 x 70		1999
New	40 x 60 1999 Marlette		1999
New	27 x 56 - 1991 Marlette Mobile Home.		1999
New	24 x52 (1979) Homet		1999
New	Rambler Style SFR - 1997 UBC		1999
New	12 X 45		1999
New	Rambler w/unfinished daylight basement.....1997 UBC		1999
New	2-Story SFR w/attached garage		1999
New	2 story SFR with attached garage		1999
New	Rambler style SFR w/attached garage.		1999
New	14 x 66 1978 Barrington/Fleetwood		1999
New	2 story Garage/Residence		1999
New	Ramber w/bonus room over the attached 2-car garage....1997 UBC		1999
New	1998 Champion 494 28 x 66		1999
New	1998 28 x 66 Champion -494		1999
New	1999 Marlette Pacifica 26x60 w/13x32 attachment		1999
New	28x60, 1999 Marlette		1999
New	28x66, 1998 Fleetwood (Green Hill)		1999
New	1984 Berkshire 60 x 28 installed without permit		1999
New	1999 Doublewide Mobile Home 27 x 66 Greenbriar		1999
New	1990 26 8 x 66 Marlana (Marlette)		1999
New	28 X 66 Palm Harbor 1999		1999
New	One-story SFR w/attached garage		1999
New	2374 2-story w/600 sf carport and 40 sf covered deck/porch		1999
New	Doublewide Mobile 28 x 66 1994 bFleetwood		1999
New	2 story sfr with finished basement		1999
New	1979 27 x 64 Fleetwood		1999
New	Rambler style SFR w/attached garage(Bonus Rm up)		1999
New	526 s.f. sfr w/950 s.f. garage		1999
New	2188 s.f. sfr with 895 finished basement		1999
New	2000 40 x 56 Oakwood		1999
New	27 x 48 1998 Fleetwood		1999
New	2-Story SFR w/attached garage. 1997-UBC		1999
New	Rambler SFR.....1997 UBC		1999
New	2-story SFR w/attached 2-car garage....1997 UBC		1999
New	24x52 (1983) Comet		1999
New	27 X 55 Palm Harbor 1999		1999
New	Rambler style duplex w/attached garage		1999
New	28x46 (1998) Fleetwood		1999
New	28x48 (1999) Fleetwood		1999
New	27x48 1999 Golden West		1999



Accessory Dwelling Units

Index # - File Name: 1.0022 - Single Family Dwellings Data\_Snohomish County.pdf

New	24 x 65ft, 1971 New Moon.	1999
New	1978 Golden Sunrise 24 x 60	1999
New	1 story sfr w/ attached garage	1999
New	New 2712sf Duplex with attached two car garages.	1999
New	1999 26 x 40 Liberty	1999
New	357 sf New Living Area & 240 sf Garage to Living Area 506 sf New Garage	1999
New	48 x 30 Marlette (1999)	1999
New	28x44, 1997 Goldenwest	1999
New	Rambler w/2 Car	1999
New	30 x 44 2-story SFR.....1997 UBC	1999
New	1980 66 x27 Oakwood DW MH	1999
New	1984 14 x 66 Fleetwood	1999
New	Rambler with attached Garage	1999
New	SFR with Finished Basement and Attached Garage	1999
New	Rambler style SFR with attached garage and deck	1999
New	Rambler Style SFR - 1997 UBC	1999
New	2 story SFR	1999
New	SFR Above Garage	1999
New	1018 s.f. sfr with 348 s.f. unfinished basement & 562 s.f. garage	1999
New	Split Level style SFR with attached garage	1999
New	Approved Basic #98-108660BP Rambler with attached garage - 1997 UBC	1999
New	Approved Basic #99-101683BP SFR w/finished basement - 1997 UBC	1999
New	Approved Basic #98-108660BP Rambler with attached garage - 1997 UBC	1999
New	Rambler style SFR w/attached garage.	1999
New	Approved Basic #98-108660BP Rambler with attached garage - 1997 UBC	1999
New	Approved Basic #98-108660BP Rambler with attached garage - 1997 UBC	1999
New	Rambler with attached garage - 1997 UBC	1999
New	Approved Basic #98-102367BP Plan 1238 SFR w/unfinished baseme	1999
New	Rambler style SFR w/attached garage	1999
New	Approved Basic #98-103332BP Plan #1238 Rambler Style SFR - 1994 UB	1999
New	Approved Basic #98-151012BP Plan #1361 2 Story Rambler	1999
New	Approved Basic #98-103332BP Plan #1238 Rambler Style SFR - 1	1999
New	Approved Basic #98-116988BP Option Approved: Main floor plan layout 2 story s	1999
New	Approved Basic #98-151012BP Plan #1361 2 Story Rambler with attached garage and covered	1999
New	Approved Basic #98-151012BP Plan #1361 2 Story Rambler	1999
New	Approved Basic #99-109515 BP Two Story SFR - 1997 UBC	1999
New	One-story SFR with finished basement, attached garage and covered porch	1999
New	1998 - 27 x 66 - Palm Harbor	1999
New	Two-story SFR w/unfin basement & attached garage	1999
New	1752 sf 2-stroy w/936 sf unfinished basement and 208 sf covered deck/porch	1999
New	27 x 48 1998 Palm Harbor	1999
New	14 x 66 Fleetwood 1997	1999
New	2 Story SFR with daylighted and attached garage - 1997UBC	1999
New	Approved Basic #98-116988BP Option Approved: Different main floor plan layout	1999
New	1999 approx 42 x 52 Skyline/Greenbrier	1999
New	1999 Golden West 28 x 60	1999
New	Approved Basic #98-116988BP Option Approved: Main floor plan layout 2 story s	1999

Accessory Dwelling Units

Index # - File Name: 1.0022 - Single Family Dwellings Data\_Snohomish County.pdf

New	2x56, 1967 Bronzwood		1999
New	27 x 52 Silvercrest Silverwood		1999
New	1884 sf rambler w/506 sf garage and 200 sf open deck(patio)		1999
New	1662 sf SFR		1999
New	SFR Rambler w/daylight basement.....1997 UBC		1999
New	2 story sfr w/3 car garage. STOP WORK, PER M. MCCRARY, 4/26/99, VIOLATION OF COND. #5.(I		1999
New	1978 - 24 x 48 - Kit - Mobile Home.		1999
New	2 Story w/finished basement & 2 Car Garage		1999
New	2 story SFR with attached garage and covered porch		1999
New	Approved Basic #99-100847BP Split w/ 2 car garage	Plan #1283	1999
New	Approved Basic #99-100847BP Split w/ 2 car garage	Plan #1283	1999
New	Approved Basic #99-100847BP Split w/ 2 car garage	Plan #1283	1999
New	Approved Basic #99-100847BP Split w/ 2 car garage	Plan #1283	1999
New	2 story sfr with finished basement and 3 car garage		1999
New	28 x 60 - 1987 Redmond		1999
New	Approved Basic #98-110231BP. Plan: Rutledge 1365 One-story SFR w/finished basement &		1999
New	Approved Basic #98-110231BP Plan: Rutledge 1365 One-story SF		1999
New	1234 s.f. with 605 finished basement & 3 car garage		1999
New	2510 sf 2-story w/346 sf unfinished basement and 784 sf garage and 72 sf covered deck/porch		1999
New	1982 26 x 40 Glen River		1999
New	27 X 66 Oakwood 1999		1999
New	2-story SFR w/attached 3-car garage.....1997 UBC. REF. 05-117098IR. gb		1999
New	Approved Basic #99-100847BP Split w/ 2 car garage - 1997 UBC	Plan #	1999
New	Approved Basic #99-100847BP Split w/ 2 car garage	Plan #1283	1999
New	24 X 48 1982 CITITION		1999
New	One-story SFR w/attached garage		1999
New	Rambler w/attached garage.....1997 UBC		1999
New	28x66, 1999 Redmond		1999
New	2200sf 2-story w/852 sf garage and 180 sf covered deck/porch		1999
New	1992 28 x 54 Fleetwood		1999
New	12 x 60 - 1973 Kentwood Mobile Home.		1999
New	Rambler w/2 Car		1999
New	1999 28 x 56 Marlette		1999
New	2000 66 x 27 w/23 x 13 Pod Goldenwest		1999
New	2 story SFR		1999
New	Approved Basic #99-101683BP Mid-Entry SFR w/finshed basement - 1997 UBC.		1999
New	1979 24 x 48 Belmont		1999
New	1986 - 27 x 60 - Fleetwood-American mansion		1999
New	Rambler w/attached 2-car garage...1997 UBC		1999
New	60x40, 1998 Silver Crest		1999
New	SFR with daylight basement		1999
New	2 story SFR with breezeway and attached garage		1999
New	2-story SFR w/attached 3-car garage....1997 UBC		1999
New	Mobile Home, 39 -10 X 66 - 8 - 1997 Silver Crest		1999
New	68x26 (1999) Marlette		1999
New	2 Story w/2 Car		1999
New	2682 rambler with 3 car garage		1999

Accessory Dwelling Units

Index # - File Name: 1.0022 - Single Family Dwellings Data\_Snohomish County.pdf

New	2 story sfr	1999
New	14 x 70 - 1984 - Fleetwood	1999
New	5125 sf 2-story w/1356 sf garage and 290 sf covered deck/porch	1999
New	(1979) 28 x 70 Goldenwest	1999
New	replacing existing SFR with new 4670 sf, two story SFR with attached two car garage.	1999
New	Approved Basic #98-110213BP	Plan #1333 Two Story Duplex - 1999
New	Approved Basic #98-110213BP	Plan #1333 Two Story Duplex - 1999
New	1090 sf rambler w/520 sf finished basement, 520 sf garage and 24 sf covered deck and 80 sf open porch	1999
New	New 1835sf two story SFR with attached two garage.	1999
New	28 x 70 1985 Guerdon	1999
New	2611 sf 2-story DUPLEX w/652 sf garage, and 168 sf covered deck/porch	1999
New	2 Story w/2 Car garage	1999
New	2 Story with attached garage and covered porch.	1999
New	1999 Marlette 8220 Pacifica 40 x 60	1999
New	Rambler style SFR with attached garage	1999
New	Two Story Duplex - 1997 UBC Plan: 1482. ***** NON-OCC NOTICE POSTED BY DOYLE BROV	1999
New	2-story SFR w/attached 2-car garage.....1997 UBC	1999
New	2-story SFR w/attached 3-car garage....1997 UBC	1999
New	2 story sfr w/2 car garage	1999
New	2 Story w/fin bsmt & 3 Car	1999
New	Rambler w/unfin daylight & 2 Car	1999
New	One-story SFR w/full unfin basement-no garage.	1999
New	Finish 792 sf unfinished basement	1999
New	4641 sf 2-story w/1017 sf garage and 264 sf covered deck/porch	1999
New	2-Story SFR w/attached garage	1999
New	2 story SFR with daylight basement and covered porch	1999
New	27 X 44 1993 Golden West - Conversion from TD to Guesthouse	1999
New	40x49, 1999 Marlette	1999
New	28 x 66 1985 Fleetwood Barrington	1999
New	1950-sf Rambler style SFR (being attached to back of existing garage.)	1999
New	1968 - 12 x 65 - TNC	1999
New	2 story SFR with carport and covered porch	1999
New	2 story SFR with attached garage	1999
New	2-story SFR w/attached 3-car garage....1997 UBC	1999
New	27x66 Oakwood (1998)	1999
New	Rambler with bonus room on second level w/attached 3-car garage...1997 UBC	1999
New	2 story sfr	1999
New	2 Story w/2 Car	1999
New	66x27, 1999 Oakwood	1999
New	New 2062sf two story SFR without garage.	1999
New	2-story SFR w/attached 1-car garage....1997 UBC	1999
New	New SFR w/ finished basement	1999
New	2-story SFR w/attached 2-car garage....1997 UBC	1999
New	1998 Oakwood 27 x 56	1999
New	1 story sfr w/ attached 3 car garage	1999
New	20 x 40 1979 Freedom	1999
New	Tri sfr w/3 car garage	1999

Accessory Dwelling Units

Index # - File Name: 1.0022 - Single Family Dwellings Data\_Snohomish County.pdf

New	New one story SFR with attached two car garage.		1999
New	2 Story w/3 Car		1999
New	Rambler style SFR w/attached 3-car garage....1997 UBC	Plan #: 2035R/3	1999
New	Rambler style SFR w/attached 3-car garage....1997 UBC	Plan #: 2135R/3	1999
New	Rambler style SFR w/attached garage; ref 99-103476 GR		1999
New	42 x 60 1999 Golden Pacific		1999
New	1090 sf 2-story w/27 sf covered deck/porch and 280 sf open deck		1999
New	2-story SFR w/attached 2-car garage.....1997 UBC		1999
New	14 x 52 Kentwood 1982 Disturbance on slopes greater than 25%. Disturbance within 65 ft. of 1		1999
New	2-story SFR w/attached single car garage.....1997 UBC		1999
New	Two-story Duplex w/attached garage		1999
New	28x48 (1980) Ridgewood		1999
New	1998 Palm Harbour 564 28 x 64		1999
New	20 x 38 1989 Fleetwood		1999
New	1978 28 x 64 Bendix Brockwood		1999
New	One-story SFR w/attached garage		1999
New	Tri-Level style SFR with attached garage and deck		1999
New	Rambler style SFR w/attached garage.		1999
New	Approved Basic #99 113125 BP	Builders Plan 1811 Split-level SFR - 1997	1999
New	EXISTING 24x63, 1976 Gentry		1999
New	28 x 56 - 1979 Skyline Mobile Home.		1999
New	Per Chris Griffith okay to take \$60.00 reinspect on this expired permit to try and get final inspe		1999
New	2583 sf 2-story w/674 sf garage		1999
New	2591 sf 2-story w/674 sf garage		1999
New	Rambler Style SFR - 1997 UBC		1999
New	Rambler w/attached 2-car garage.....1997 UBC		1999
New	Rambler w/ 2 Car		1999
New	2175 sf 2-story geodesic dome w/ 1250 sf finished basement		1999
New	Rambler w/attached 3-car garage.....1997 UBC		1999
New	2-story SFR w/3-car attached garage....1997 UBC		1999
New	2-story SFR w/attached 2-car garage...1997 UBC		1999
New	36 x 66 - 1998 - Fleetwood		1999
New	2-Story SFR w/attached Garage & Covered porches.		1999
New	New 1935sf SFR with attached two car garage.		1999
New	Convert existing SFR to a DUPLEX		1999
New	Two-story SFR w/attached garage		1999
New	2600 sq ft Single-Story Duplex w/attached 2-car garages....1997 UBC		1999
New	New 2602sf SFR with 1447sf unfinished basement and attached two car garage.		1999
New	2784sf two story duplex with Four car garage.		1999
New	28 x 66ft, 1988 Fleetwood		1999
New	Two-story SFR w/finished basement & attached garage on existing foundation.		1999
New	1438 sf rambler w/1428 sf finished basement w/315 sf covered deck/porch, and 78 sf open dec		1999
New	2 story sfr with 3 car garage with bonus room above garage		1999
New	2-story w/full basement.....1997 UBC		1999
New	Approved Basic #98-108977BP	Plan #1344 R Two Story SFR - 1997 UB	1999
New	2 Story w/ 2 Car garage and breezeway		1999
New	SFR with Daylight Basement		1999

Accessory Dwelling Units

Index # - File Name: 1.0022 - Single Family Dwellings Data\_Snohomish County.pdf

New	2 story SFR with attached garage		1999
New	1981 Fleetwood/Greenbrier 24 x 56		1999
New	2 Story w/Attached Garage/shop, covered porch		1999
New	1977 28 x 68 Sunnybrook		1999
New	2 story sfr with unfinished basement & 3 car garage		1999
New	Rambler w/2 Car. CHRIS GRIFFITH POSTED A NON OCCUPANCY ON 1/11/00.		1999
New	2-story SFR w/attached 3-car garage.....1997 UBC		1999
New	2 story Rambler with attached garage		1999
New	Tri-Level SFR with Attached Garage		1999
New	Two-story SFR w/attached garage		1999
New	Two-story SFR w/attached garage		1999
New	3178 sf 2-story DUPLEX w/800 sf garage and 160 sf covered deck/porch		1999
New	2 Story w/3 car		1999
New	2300 sq ft SFR.....1997 UBC		1999
New	2094 sf rambler w/720 sf garage and 54 sf covered porch		1999
New	2-story SFR w/detached garage.....1997 UBC		1999
New	1998 27 x 66 Oakwood		1999
New	Detached Accessory Apt.		1999
New	2-Story SFR w/attached garage.		1999
New	2 story sfr with unfinished basement & 3 car garage		1999
New	2273 sf rambler w/813 sf unfinished basement and 1038 sf garage and 14 sf covered porch		1999
New	One-story SFR w/attached garage on existing foundation.		1999
New	1256 s.f. w/unfinished basement & 2 car garage		1999
New	2 story sfr with 3 car garage		1999
New	SFR over Garage.		1999
New	2 Story SFR w/attached Garage. EXPIRED W/O COUNTY APPROVAL TO OCCUPY OR USE. PERMI		1999
New	3434 sf SFR w/1609 sf garage/workshop and 775 sf covered deck/porch		1999
New	2094 sf rambler w/1624 sf unfinished basement and 1056 sf garage and 120sf covered deck/po		1999
New	Re-build SFR as a result of fire damage (using existing foundation)		1999
New	Two Story SFR with Attached Garage		1999
New	2 Story with daylighted - 1997 UBC		1999
New	27 x 66 1998 Oakwood Double wide		1999
New	53 4 x 27 1999 Mobile Home		1999
New	14 x 70 - 1978 - Liberty		1999
New	1999 28 x 60 Palm Harbor		1999
New	40 x 66 - 1999 - Oakwood Classic		1999
New	New two story SFR with attached two car garage.		1999
New	14 x 70 - 1980 - Fleetwood		1999
New	Rambler Style SFR - 1994 UBC		1999
New	Rambler Style SFR - 1994 UBC		1999
New	Two Story SFR - 1997 UBC	Plan: 3059/3	1999
New	Two Story SFR - 1997 UBC		1999
New	Two Story SFR - 1997 UBC	Plan: 2735	1999
New	Two Story SFR - 1997 UBC	Plan: K 2745	1999
New	Two Story SFR - 1997 UBC		1999
New	Two Story SFR - 1997 UBC	Plan: K2646	1999
New	Two Story SFR - 1997 UBC	Plan: #K2738 B	1999

Accessory Dwelling Units

Index # - File Name: 1.0022 - Single Family Dwellings Data\_Snohomish County.pdf

New	Two Story SFR - 1997 UBC	Plan: #K2745A	1999
New	Rambler style SFR with attached garage		1999
New	New 3428 sf two story SFR with attached three car garage		1999
New	2 Story w/3 Car		1999
New	2-story SFR w/3-car garage.....1997 UBC		1999
New	Two Story SFR with Attached Garage		1999
New	2 story sfr with 3 car garage		1999
New	Two Story SFR - 1997 UBC	Plan: 3920 B/3SG	1999
New	2 Story w/3 Car		1999
New	3691 sf 2-story w/919sf garage and 96 sf covered deck/porch		1999
New	Two-story SFR w/attached garage		1999
New	2-story SFR w/attached 3-car garage.....1997 UBC		1999
New	28 x 70 1982 Liberty		1999
New	Two-story SFR w/attached garage		1999
New	27.5 x 56.5 - 1992 - Golden West		1999
New	Two-story SFR w/fin bsmt & garage (boat storage)		1999
New	Daylight Basement Style SFR w/Covered Deck		1999
New	Rambler with attached garage - 1997 UBC		1999
New	Approved Basic #98-110231BP	Plan: Rutledge 1365 One-story SFF	1999
New	Approved Basic #98-151009BP	Plan: 3 Bedroom Rambler Style SFR -	1999
New	1830 s.f. rambler w/2 car garage		1999
New	2064 sf rambler w/528 sf garage		1999
New	2064 sf rambler w/528 sf garage		1999
New	2-story SFR w/attached 3-car garage....1997 UBC		1999
New	Approved Basic #98-151008BP	Plan: 3 Bedroom A Rambler Style SFR	1999
New	Approved Basic #98-151011BP	Plan: 4 Bedroom Rambler Style SFR -	1999
New	Approved Basic #98-151009BP	Plan: 3 Bedroom Rambler Style SFR -	1999
New	Approved Basic #98-151008BP	Plan: 3 Bedroom A Rambler Style SFR	1999
New	Approved Basic #98-151011BP	Plan: 4 Bedroom Rambler Style SFR -	1999
New	Approved Basic #98-151009BP	Plan: 3 Bedroom Rambler Style SFR -	1999
New	Approved Basic #98-151011BP	Plan: 4 Bedroom Rambler Style SFR -	1999
New	Approved Basic #98-151008BP	Plan: 3 Bedroom A Rambler Style SFR	1999
New	Approved Basic #98-151010BP	Plan: 2 Bedroom Rambler Style SFR -	1999
New	Approved Basic #98-151009BP	Plan: 3 Bedroom Rambler Style SFR -	1999
New	Approved Basic #98-151008BP	Plan: 3 Bedroom A Rambler Style SFR	1999
New	Approved Basic #98-151009BP	Plan: 3 Bedroom Rambler Style SFR -	1999
New	2 story sfr with 3 car garage		1999
New	2-story SFR w/attached 3-car garage.....1997 UBC		1999
New	Two Story SFR with Attached Garage		1999
New	SFR with Finished Basement and Attached Garage - 1997 UBC		1999
New	Rambler w/loft SFR.....1997 UBC		1999
New	One-story SFR with unfinished basement & attached garage		1999
New	2-Story SFR over unfin. daylight basement w/attached garage.		1999
New	2 Story SFR with Attached 3 Car Garage		1999
New	2 Story SFR with attached garage - 1997 UBC		1999
New	2-Story SFR w/attached garage.		1999
New	2300 s.f. with 3 car garage		1999

Accessory Dwelling Units

Index # - File Name: 1.0022 - Single Family Dwellings Data\_Snohomish County.pdf

New	2-Story SFR with unfin. Basement & Attached Garage. CLOSED W/O FINAL. SEE 01-112717.	1999
New	1978 -24 x 56 - Versailles	1999
New	New 2123sf SFR	1999
New	One-story SFR w/attached garage	1999
New	2 story SFR with semi finished basement and attached garage	1999
New	1999 27 x 66 Silvercrest	1999
New	1999 27 x 60 Silvercrest	1999
New	1999 Goldenwest 28 x 52	1999
New	28 X 52 Silvercrest 1999	1999
New	28 x 48 Goldenwest MH	1999
New	1999 Golden West 28 x 66	1999
New	1999 Marlett 28 x 56	1999
New	28 x 52 - 1999 - Silvercrest Mobile Home.	1999
New	1999 27 x 56 Marlette	1999
New	28 x 52 - 1999 Silvercrest Mobile Home	1999
New	27 x 54 1999 Marlette	1999
New	1999 Pacifica 8211A 27 x 52	1999
New	2 story duplex with attached 2 car garages	1999
New	Approved Basic #99-103617BP	Two Story duplex with 2 car garage
New	Two-story SFR w/attached garage	1999
New	1999 Golden West 27 x 48	1999
New	Two-story SFR w/attached garage	1999
New	27 x 48 - 1999 - Palm Harbour #448.	1999
New	Two Story SFR	1999
New	24x44, 1995 Gibraltar	1999
New	2-story SFR w/garage.....1997 UBC	1999
New	2 Story w/ 3 Car	1999
New	28 x 60 Fleetwood	1999
New	2 story SFR with attached carport, covered porch and deck	1999
New	Approved Basic #98-151008BP	Plan: 3 Bedroom A Rambler Style SFR
New	Approved Basic #98-108181BP	(3 Bedrooms) Two Story SFR - 1997 UBC
New	2 story SFR with attached garage and unfinished bonus room above garage	1999
New	2 story with a daylight basement, attached garage and deck. REF: voided permit 97-107275.	1999
New	Rambler w/unfinished basement & attached 2-car garage through a breezeway.....1997 UBC	1999
New	Approved Basic #98-151008BP	Plan: 3 Bedroom A Rambler Style SFR
New	Approved Basic #98-151008BP	Plan: 3 Bedroom A Rambler Style SFR
New	Approved Basic #98-151008BP	Plan: 3 Bedroom A Rambler Style SFR
New	Approved Basic #98-151008BP	Plan: 3 Bedroom A Rambler Style SFR
New	Approved Basic #98-151008BP	Plan: 3 Bedroom A Rambler Style SFR
New	Approved Basic #98-151008BP	Plan: 3 Bedroom A Rambler Style SFR
New	Approved Basic #98-151010BP	Plan: 2 Bedroom Rambler Style SFR - :
New	Approved Basic #98-151010BP	Plan: 2 Bedroom Rambler Style SFR - :
New	Approved Basic #98-151010BP	Plan: 2 Bedroom Rambler Style SFR - :
New	Approved Basic #98-151008BP	Plan: 3 Bedroom A Rambler Style SFR
New	Two Story SFR - 1997 UBC	Plan #487
New	SFR w/finished lower floor - 1997 UBC	Plan #292
New	Approved Basic #98-116359BP	Plan: 394 SFR w/finished lower fl

Accessory Dwelling Units

Index # - File Name: 1.0022 - Single Family Dwellings Data\_Snohomish County.pdf

New	Approved Basic #99-101116BP	SFR w/finished lower floor - 1997 UBC	Plan #	1999
New	Approved Basic #98-108180BP	( 2 Bedrooms) Rambler Style SFR - 199		1999
New	Approved Basic #99-101116BP	SFR w/finished lower floor - 1997 UBC	Plan #	1999
New	Approved Basic #98-116359BP	Plan: 394 SFR w/finished lower fl		1999
New	Approved Basic #98-116359BP	Plan: 394 SFR w/finished lower fl		1999
New	Approved Basic #99-101116BP	SFR w/finished lower floor - 1997 UBC	Plan #	1999
New	Approved Basic #98-108179BP	(3 Bedroom) Two Story SFR - 1994 UBC		1999
New	Approved Basic #98-116359BP	Plan: 394 SFR w/finished lower fl		1999
New	Approved Basic #98-108179BP	(3 Bedroom) Two Story SFR - 1994 UBC		1999
New	Approved Basic #98-116359BP	Plan: 394 SFR w/finished lower fl		1999
New	Approved Basic #98-108179BP	(3 Bedroom) Two Story SFR - 1994 UBC		1999
New	Approved Basic #99-113272BP	(3 Bedrooms) Two Story SFR - 1997 UBC		1999
New	Approved Basic #98-116359BP	Plan: 394 SFR w/finished lower fl		1999
New	Approved Basic #99-100561BP	Two Story SFR - 1997 UBC	Plan #48	1999
New	Approved Basic #99-100561BP	Two Story SFR - 1997 UBC	Plan #48	1999
New	Approved Basic #98-116359BP	Plan: 394 SFR w/finished lower fl		1999
New	Approved Basic #98-108181BP	(3 Bedrooms) Two Story SFR - 1997 UBC		1999
New	Approved Basic #98-108179BP	(3 Bedroom) Two Story SFR - 1994 UBC		1999
New	Approved Basic #98-109549BP	Two Story SFR - 1997 UBC	Plan #496 A,	1999
New	Approved Basic #98-116359BP	Plan: 394 SFR w/finished lower fl		1999
New	Approved Basic #98-108179BP	(3 Bedroom) Two Story SFR - 1994 UBC		1999
New	Approved Basic #98-116359BP	Plan: 394 SFR w/finished lower fl		1999
New	Rambler SFR w/attached 2-car carport.....1997 UBC			1999
New	Approved Basic #98-108179BP	(3 Bedroom) Two Story SFR - 1994 UBC		1999
New	Approved Basic #99-101116BP	SFR w/finished lower floor - 1997 UBC	Plan #	1999
New	Approved Basic #98-116359BP	Plan: 394 SFR w/finished lower fl		1999
New	Approved Basic #98-116359BP	Plan: 394 SFR w/finished lower fl		1999
New	Approved Basic #99-100564BP	Two Story SFR - 1997 UBC	Plan #48	1999
New	Approved Basic #98-108179BP	(3 Bedroom) Two Story SFR - 1994 UBC		1999
New	Approved Basic #98-116359BP	Plan: 394 SFR w/finished lower fl		1999
New	Approved Basic #99-100561BP	Two Story SFR - 1997 UBC	Plan #48	1999
New	Approved Basic #99-100561BP	Two Story SFR - 1997 UBC	Plan #48	1999
New	Approved Basic #99-100564BP	Two Story SFR - 1997 UBC	Plan #48	1999
New	Approved Basic #98-108179BP	(3 Bedroom) Two Story SFR - 1994 UBC		1999
New	Approved Basic #99-100564BP	Two Story SFR - 1997 UBC	Plan #48	1999
New	Approved Basic #98-116359BP	Plan: 394 SFR w/finished lower floor - 1997 U		1999
New	Approved Basic #99-101116BP	SFR w/finished lower floor - 1997 UBC	Plan #	1999
New	Approved Basic #99-100564BP	Two Story SFR - 1997 UBC	Plan #48	1999
New	Two Story SFR - 1997 UBC	Plan: #493		1999
New	Approved Basic #98-116789BP	Plan #493 Two Story SFR - 1997 UB		1999
New	Approved Basic #98-108179BP	(3 Bedroom) Two Story SFR - 1994 UBC		1999
New	Approved Basic #99-101116BP	SFR w/finished lower floor - 1997 UBC	Plan #	1999
New	Two Story SFR - 1997 UBC	Plan #486		1999
New	Two Story SFR - 1997 UBC	Plan #496 A/B		1999
New	Approved Basic #98-116359BP	Plan: 394 SFR w/finished lower fl		1999
New	Approved Basic #98-108181BP	(3 Bedrooms) Two Story SFR - 1997 UBC		1999
New	Approved Basic #98-108179BP	(3 Bedroom) Two Story SFR - 1994 UBC		1999



Accessory Dwelling Units

Index # - File Name: 1.0022 - Single Family Dwellings Data\_Snohomish County.pdf

New	Approved Basic #95-109111BP	Plan #1876	Two Story SFR - 1994 UBC	1999
New	1876 sf 2-story w/730 sf garage			1999
New	Approved Basic 99-103302BP		2 Story w/3 Car	1999
New	Approved Basic #95-109111BP	Plan #1876	Two Story SFR - 1994 UBC	1999
New	2203 sf rambler w/2 car garage & carport			1999
New	28 x 56 - 1986 - Fleetwood			1999
New	2-story with attached one-garage.....1997 UBC			1999
New	Approved Basic #98-109460BP	Plan # A-311 a/b	Two Story SFR - 1997 UB	1999
New	Two Story SFR - 1997 UBC	Plan #G-507-b		1999
New	Approved Basic #98-109460BP	Plan # A-311 a/b	Two Story SFR - 1997 UB	1999
New	Two Story SFR - 1997 UBC	Builders Plan #G510-C		1999
New	Approved Basic #98-109468BP	Plan # B-406 c/d	Two Story SFR - 1997 U	1999
New	Approved Basic #98-109460BP	Plan # A-311 a/b	Two Story SFR - 1997 UB	1999
New	Approved Basic #98-109471BP	Plan # G-517 a/b(4)	Two Story SFR - 1997	1999
New	Approved Basic #98-109468BP	Plan # B-406 c/d	Two Story SFR - 1997 U	1999
New	Approved Basic #99-110174 BP	Two Story SFR - 1997 UBC	Plan: G	1999
New	Approved Basic #98-109473BP	Plan # G-517 a/b	Two Story SFR - 1997 U	1999
New	Approved Basic #98-109472BP	Plan # G-507-b	Two Story SFR - 1997 UBC	1999
New	Approved Basic #98-109476BP	Plan #B409 e/f	Two Story SFR - 1997 UBC	1999
New	Approved Basic #98-109468BP	Plan # B-406 c/d	Two Story SFR - 1997 U	1999
New	Approved Basic #98-109460BP	Plan # A-311 a/b	Two Story SFR - 1997 UB	1999
New	Approved Basic #99-110174 BP	Two Story SFR - 1997 UBC	Plan: G	1999
New	Approved Basic #98-109468BP	Plan # B-406 c/d	Two Story SFR - 1997 U	1999
New	Rambler style SFR with attached garage and covered porches			1999
New	2-Story SFR w/attached garage - 1997 UBC			1999
New	1975 14 x 70 Concord			1999
New	Approved Basic #98-116177BP	Rambler Style SFR - 1997 UBC		1999
New	2164 sf 2-story w/714 sf garage and 108 sf covered deck/porch			1999
New	New 2535 sf single story SFR with attached two car garage.			1999
New	New three story with attached two car garage.			1999
New	New three story with two car garage and 768sf storage area in basement			1999
New	Two Story SFR - 1997 UBC			1999
New	2-story SFR w/attached 3-car garage...1997 UBC			1999
New	Two-story SFR w/attached garage			1999
New	Approved Basic #98-110563BP	Plan 2146	Two Story SFR - 1997 UBC	1999
New	2-story SFR w/attached 3-car garage....1997 UBC			1999
New	2 story SFR w/ 3 car garage w/ unfinished basement			1999
New	Rambler with Attached Garage			1999
New	2 story SFR w 3 car garage w/ unfinished basement			1999
New	2 Story w/Unfin Bsmt & 3 Car			1999
New	Approved Basic #98-109993BP	Builders #1715	2-Story SFR w/attached g	1999
New	40 x 66 1999 Goldenwest`			1999
New	2 Story w/3 Car			1999
New	Split entry style SFR w/basement garage - 1997 UBC			1999
New	Split w/2 car			1999
New	two story SFR with attached three car garage.			1999
New	SFR (Cabin) with covered porch			1999

Accessory Dwelling Units

Index # - File Name: 1.0022 - Single Family Dwellings Data\_Snohomish County.pdf

New	Rambler w/1 Car	1999
New	Rambler w/2 Car	1999
New	2 story SFR with daylight basement and attached garage	1999
New	2548 sq FT two story w/ 704 sq ft garage and 448 sq ft covered deck/porch	1999
New	2700 sf 2-story w/680 sf garage and 228 sf covered deck/porch	1999
New	Approved Basic #98-102233 BP	Blders Plan: 2226 2 Story SFR with attac
New	2 story sfr w/3 car garage	1999
New	2149 sgf 2-story w/685 sf garage and 24 sf covered deck/porch; and 96 sf open deck	1999
New	2127 sf two story SFR with attached two car garage.	1999
New	Daylight Basement w/3 Car	1999
New	Approved Basic 99-104905BP	Rambler Style SFR - 1997 UBC
New	Approved Basic 99-104905BP	Rambler Style SFR - 1997 UBC
New	Approved Basic #97-104356BP	Rambler Style SFR - 1994 UBC
New	Approved Basic #98-105836BP	BUILDERS NO. C041592 2 Story w
New	1999 - 26 -6 X 66 - Liberty	1999
New	Two-story SFR w/attached garage	1999
New	Ramber w/attached 3-car garage.....1997 UBC	1999
New	2-story SFR w/attached garage.....1997 UBC	1999
New	Two Story SFR with Attached Garage	1999
New	Two Story SFR with Attached Garage	1999
New	Approved Basic #98-106424BP	Plan #8230 Two Story SFR - 1994
New	Two-story SFR w/attached 3-car garage	1999
New	Rambler w/daylight basement w/attached 2-car garage....1997 UBC	1999
New	Pending Basic #99-110065-BP	Bldrs Plan # 7360. 2-Story SFR w/attached 3-c
New	Two-story SFR w/attached garage	1999
New	Two Story SFR - 1997 UBC	1999
New	Two-story SFR w/attached garage	1999
New	2384 sf, two story SFR with attached three car garage.	1999
New	2619 sf w/2109 sf unfinished basement, 648 sf garage and 482 sf covered deck/porch	1999
New	Two Story SFR with Attached Garage	1999
New	Two-story SFR with unfin upstairs bonus room	1999
New	2327sf SFR with attached three car garage	1999
New	Approved Basic #99-109328 BP	2 story SFR with attached garge -- 1997 UBC
New	Approved Basic #99-109701 BP	Builder Plan # 7856 Two Story SFR - 199
New	2-Story SFR with attached garage - 1994 UBC	1999
New	Two-story SFR w/attached garage	1999
New	Rambler w/daylight basement & attached 3-car garage....1997 UBC	1999
New	2 story SFR with attached	1999
New	3924 s.f. with 1542 s.f. daylight basement & 3 car garage	1999
New	2-Story SFR w/attached garage	1999
New	2 Story w/3 Car	1999
New	Two Story SFR - 1994 UBC	1999
New	Approved Basic #98-150489BP	Builders Plan #1500 Split level with attache
New	2-Story SFR w/attached garage	1999
New	Rambler style SFR w/attached garage	1999
New	1999 Oakwood 28 x 60	1999
New	Two-story SFR w/attached garage	1999

Accessory Dwelling Units

Index # - File Name: 1.0022 - Single Family Dwellings Data\_Snohomish County.pdf

New	Two Story SFR - 1997 UBC		1999
New	2-Story SFR w/attached garage		1999
New	Rambler w/Finished daylight bsmt & 3 Car Garage		1999
New	Two-story SFR w/attached garage/shop		1999
New	Rambler w/daylight basement & attached 3-car garage....1997 UBC		1999
New	1868 sf multi level w/1455 sf finished basement, 843 sf garage and 74 sf covered deck/porch		1999
New	Rambler w/3-car attached garage.....1997 UBC		1999
New	2415 sf 2-story w/609 sf garage and 100 sf covered porch		1999
New	SFR with loft - 1997 UBC		1999
New	Mid entry SFR with basement garage		1999
New	27 X 49 Palm Harbor 1999		1999
New	2 story SFR with attached garage		1999
New	Rambler Style SFR - 1997 UBC	Plan: Rambler	1999
New	2-Story SFR w/attached garage - 1997-UBC 1997-WSEC		1999
New	3351 sf rambler w/1004 sf garage and 360 sf covered deck/porch. Non Occupancy posted 8/3/00		1999
New	Rambler Style SFR w/attached garage w/bonus room above.		1999
New	Approved Basic 99-102335BP 1997 UBC 2 story SFR with attached garage		1999
New	2 story SFR with attached garage		1999
New	1438 sf 2-story cabin		1999
New	Two Story SFR - 1997 UBC	Plan: HP18	1999
New	Two Story SFR - 1997 UBC. INSPECTED AND FINALED UNDER 99-109488, MARCH 22, 2000.		1999
New	Two Story SFR - 1997 UBC		1999
New	2 story sfr w/ attached garage		1999
New	Two Story SFR - 1997 UBC	Plan: HP10	1999
New	Two Story SFR - 1997 UBC	Plan: HP08	1999
New	Two Story SFR - 1994 UBC	Plan # HP01	1999
New	One-story SFR w/attached garage - 1997 UBC		1999
New	68 X 14 Kentwood (1973)		1999
New	2-Story SFR w/attached garage.		1999
New	2 story sfr with garage		1999
New	2 story sfr with 2 car garage		1999
New	Two story SFR		1999
New	Approved Basic #98-110147BP	Builders Plan #Unit A Two Story SFR - 1997	1999
New	Approved Basic #98-110147BP	Builders Plan #Unit A Two Story SFR - 1997	1999
New	Approved Basic #98-110147BP	Builders Plan #Unit A Two Story SFR - 1997	1999
New	Approved Basic #98-110147BP	Builders Plan #Unit A Two Story SFR - 1997	1999
New	Two Story SFR - 1997 UBC	Plan: Unit E	1999
New	Approved Basic #98-150477BP	Builders Plan: Virginia 2449 sf 2-story w/57	1999
New	Approved Basic #98-116263BP	Plan #2188 Two Story SFR - 1997 UBC	1999
New	Approved Basic #98-116267BP	Plan: North Carolina w/den Two Story	1999
New	Approved Basic #98-116917BP	Plan: West Virginia w/no den Two Story SFR	1999
New	Approved Basic 98-116834BP	Plan #1903 Rambler Style SFR - 1997 UBC	1999
New	Approved Basic 98-116834BP	Plan #1903 Rambler Style SFR - 1997 UBC	1999
New	New 1927sf SFR with attached two car garage.		1999
New	Approved Basic #98-151028BP	Plan: North Carolina without den Two Story SFR	1999
New	Approved Basic #98-116263BP	Plan #2188 Two Story SFR - 1997 UBC	1999
New	Approved Basic 98-116834BP	Plan #1903 Rambler Style SFR - 1997 UBC	1999

Accessory Dwelling Units

Index # - File Name: 1.0022 - Single Family Dwellings Data\_Snohomish County.pdf

New	Approved Basic #98-116263BP	Plan #2188 Two Story SFR - 1997 UBC	1999
New	Approved Basic #98-151028BP	Plan: North Carolina without den Two	1999
New	Approved Basic #98-116918BP	Plan: South Carolina w/no den Two Stor	1999
New	840 sf detached accessory apartment w/1260 sf garage		1999
New	Lindal Cedar Home SFR with daylight basement		1999
New	1999 Palm Harbor 27 x 48		1999
New	2-Story SFR over finished basement w/attached garage.		1999
New	Approved Basic #98-151012BP	Plan #1361 2 Story Rambler	1999
New	2217 sf 2-story w/440 sf garage		1999
New	Two-story SFR w/attached garage		1999
New	2470 sf 2-story w/440 sf garage		1999
New	Two-story SFR w/attached garage		1999
New	Approved Basic #98-116553BP	Plan: Kimberly IV Two Story SFR	1999
New	Approved Basic #98-116553BP (with or without optional cant. bay in kitchen nook)		1999
New	Approved Basic #98-116553BP (with or without optional cant. bay in kitchen nook)		1999
New	Approved Basic #99-102451BP	Plan: Cindy SFR w/finished basement -	1999
New	Approved Basic #98-116554BP	Plan: Michelle IV Two Story SFR -	1999
New	Approved Basic #98-116553BP	Plan: Kimberly IV Two Story SFR	1999
New	Approved Basic #98-116553BP (with or without optional cant. bay in kitchen nook)		1999
New	Approved Basic #98-116553BP (with or without optional cant. bay in kitchen nook)		1999
New	Approved Basic #99-102451BP	Plan: Cindy SFR w/finished basement -	1999
New	Approved Basic #99-102451BP	Plan: Cindy SFR w/finished basement -	1999
New	Approved Basic #98-116553BP (with or without optional cant. bay in kitchen nook)		1999
New	Approved Basic #98-116553BP	Plan: Kimberly IV Two Story SFR	1999
New	Approved Basic #98-116554BP	Plan: Michelle IV Two Story SFR -	1999
New	Approved Basic #98-116554BP	Plan: Michelle IV Two Story SFR -	1999
New	Approved Basic #98-116553BP	Plan: Kimberly IV Two Story SFR	1999
New	Approved Basic #98-116554BP	Plan: Michelle IV Two Story SFR -	1999
New	Approved Basic #98-116553BP (with or without optional cant. bay in kitchen nook)		1999
New	Approved Basic #99-102451BP	Plan: Cindy SFR w/finished basement -	1999
New	Approved Basic #98-116554BP	Plan: Michelle IV Two Story SFR -	1999
New	Approved Basic #99-102451BP	Plan: Cindy SFR w/finished basement -	1999
New	Approved Basic #99-102451BP	Plan: Cindy SFR w/finished basement -	1999
New	Approved Basic #98-116554BP	Plan: Michelle IV Two Story SFR - 1997 UBC	1999
New	Approved Basic #98-116553BP (with or without optional cant. bay in kitchen nook)		1999
New	Approved Basic #99-102451BP	Plan: Cindy SFR w/finished basement -	1999
New	Approved Basic #98-116553BP (with or without optional cant. bay in kitchen nook)		1999
New	Approved Basic #98-116554BP	Plan: Michelle IV Two Story SFR -	1999
New	Approved Basic #99-102451BP	Plan: Cindy SFR w/finished basement -	1999
New	Two-story SFR w/attached garage.		1999
New	Two-story SFR w/attached garage		1999
New	Approved Basic #98-116925BP	Plan: 1885 T/A Tri-Level SFR - 1997	1999
New	Mid-Entry w/attached 2-car garage.....1997 UBC	Plan: 2195/B Special *\$60.00 Re-fee	1999
New	28 x 45, 1999 Oakwood		1999
New	504sf SFR		1999
New	Approved Basic #98-116929	Plan: 1942 A/2 Two Story SFR - 199	1999
New	Approved Basic #98-116925BP	Plan: 1885 T/A Tri-Level SFR - 1997	1999

Accessory Dwelling Units

Index # - File Name: 1.0022 - Single Family Dwellings Data\_Snohomish County.pdf

New	28 x 66	1999 Goldenwest MH		1999
New		New Two story SFR with attached two car garage.		1999
New		2 Story w/3Car		1999
New		2-story SFR w/attached garage - 1997 UBC		1999
New		2400 sq ft Duplex w/2 2-car attached garages.....1997 UBC		1999
New		Two-story SFR w/attached garage		1999
New		Rambler w/2 Car - 1997 UBC		1999
New		Approved Basic #98-109993BP	Builders #1715 2-Story SFR w/attached g	1999
New		Two-story SFR w/attached garage		1999
New		Approved Basic #98-109884BP	Two Story SFR -1997 UBC Plan: #253	1999
New		Approved Basic #98-109887BP	Two Story SFR -1997 UBC Plan: #284	1999
New		Two Story SFR - 1997 UBC	Plan: #3289 Elv. A,B,C	1999
New		Two Story SFR -1997 UBC	Plan: #2088 A,B	1999
New		New two story , with two car SFR.		1999
New		Approved Basic #98-109887BP	Two Story SFR -1997 UBC Plan: #284	1999
New		Approved Basic #98-109884BP	Two Story SFR -1997 UBC Plan: #253	1999
New		Approved Basic #98-109888BP	Two Story SFR - 1997 UBC Plan: #237	1999
New		Approved Basic #98-109884BP	Two Story SFR -1997 UBC Plan: #253	1999
New		Approved Basic #98-109888BP	Two Story SFR - 1997 UBC Plan: #237	1999
New		SFR w/unfinished basement & attached garage		1999
New		28x56 (1999) Fleetwood		1999
New		Rambler style SFR w/attached garage		1999
New		2131 s.f. rambler with 2 car garage		1999
New		Approved Basic #98-109993BP	Builders #1715 2-Story SFR w/attached g	1999
New		Approved Basic #98-116328BP	Plan: 2190 Two Story SFR - 1997 U	1999
New		Two story with attached two car garage.		1999
New		Approved Basic #98-116328BP	Plan: 2190 Two Story SFR - 1997 U	1999
New		2115 sf 2-story w/804 sf garage and 36 sf covered deck/porch		1999
New		Approved Basic # 99-100519BP	Bldrs Plan #1960. Split entry SFR w/	1999
New		Approved Basic #98-109993BP	Builders #1715 2-Story SFR w/attached g	1999
New		2 story sfr w/garage		1999
New		Two Story SFR with Attached Garage		1999
New		Two Story SFR with Attached Garage		1999
New		1812 sf 2-story w/984 sf finished basement and 410 sf garage, and 64 sf covered porch		1999
New		Existing 12 x 56ft single wide MH on lot to be permitted.		1999
New		2 Story SFR with attached garage and unfinished basement - 1997 UBC		1999
New		One-story SFR w/attached garage & carport		1999
New		Split w/2 Car		1999
New		2 story SFR with attached garage and covered porch		1999
New		Approved Basic #98-107784BP	Plan: #Bldg. 3 Two Story SFR - 1997 UE	1999
New		1999 28 x 44 Liberty		1999
New		Approved Basic #98-109410BP	Plan: 1644 Split Level SFR - 1997 U	1999
New		Approved Basic #99-101345BP	Plan: 1352 SFR w/unfinished ba:	1999
New		Approved Basic #98-109408BP	Plan: 1705 SFR w/unfinished lower	1999
New		Approved Basic #98-109410BP	Plan: 1644 Split Level SFR - 1997 U	1999
New		New 3088 sf SFR, with attached two car garage with unfinished storage area on second floor		1999
New		Approved Basic #98-109408BP	Plan: 1705 SFR w/unfinished lower	1999

Accessory Dwelling Units

Index # - File Name: 1.0022 - Single Family Dwellings Data\_Snohomish County.pdf

New	Approved Basic #98-109410BP		Plan: 1644 Split Level SFR - 1997 U	1999
New	Approved Basic #98-150447BP		Plan: 1223 Rambler Style SF	1999
New	Approved Basic #98-109410BP		Plan: 1644 Split Level SFR - 1997 U	1999
New	Approved Basic #98-150447BP		Plan: 1223 Rambler Style SF	1999
New	Approved Basic #99-101587BP	2 Story SFR/ 2 car garage	Plan #	1999
New	Approved Basic #98-150447BP		Plan: 1223 Rambler Style SF	1999
New	Approved Basic #98-109410BP		Plan: 1644 Split Level SFR - 1997 U	1999
New	Approved Basic #99-101587BP	2 Story SFR/ 2 car garage	Plan #	1999
New	Approved Basic #98-109408BP		Plan: 1705 SFR w/unfinished lower	1999
New	Approved Basic #98-109408BP		Plan: 1705 SFR w/unfinished lower	1999
New	Approved Basic #99-101345BP		Plan: 1352 SFR w/unfinished ba:	1999
New	Approved Basic #98-109408BP		Plan: 1705 SFR w/unfinished lower	1999
New	Approved Basic #98-109410BP		Plan: 1644 Split Level SFR - 1997 U	1999
New	Approved Basic #98-109408BP		Plan: 1705 SFR w/unfinished lower	1999
New	Approved Basic #99-101345BP		Plan: 1352 SFR w/unfinished ba:	1999
New	Approved Basic #98-109408BP		Plan: 1705 SFR w/unfinished lower	1999
New	2 Story SFR/ 2 car garage	Plan #1514 PENDING BASIC		1999
New	Approved Basic #98-109408BP		Plan: 1705 SFR w/unfinished lower	1999
New	Approved Basic #99-101345BP		Plan: 1352 SFR w/unfinished ba:	1999
New	Approved Basic #98-109408BP		Plan: 1705 SFR w/unfinished lower	1999
New	Approved Basic #99-101587BP	2 Story SFR/ 2 car garage	Plan #	1999
New	Approved Basic #98-1050447BP		Plan: 1223 Rambler Style SFR - 19	1999
New	Approved Basic #99-101345BP		Plan: 1352 SFR w/unfinished ba:	1999
New	Two Story SFR - 1997 UBC		Plan: 1514	1999
New	Approved Basic #99-101587BP	2 Story SFR/ 2 car garage	Plan #1514	1999
New	Approved Basic #98-1167BP		Plan: 1765 Two Story SFR - 1997 UBC	1999
New	SFR w/unfinished basement - 1997 UBC			1999
New	Approved Basic #98-150447BP		Plan: 1223 Rambler Style SF	1999
New	Approved Basic #99-101345BP		Plan: 1352 SFR w/unfinished ba:	1999
New	New 1284, sf two story SFR with attached two car garage.			1999
New	New 1284, sf two story SFR with attached two car garage.			1999
New	New 1284, sf two story SFR with attached two car garage.	RSP submitted 4/5/99		1999
New	Approved Basic #98-1162BP		Plan 1744 Tri-Level SFR - 1997	1999
New	Approved Basic #98-116233BP	Tri level SFR w/finished lower floor - 1997 UBC	Plan	1999
New	Approved Basic #99-101802BP		Plan: 1450 S SFR w/finished basemei	1999
New	Approved Basic #99-101802BP		Plan: 1450 S SFR w/finished basemei	1999
New	Approved Basic #98-1167BP		Plan: 1765 Two Story SFR - 1997 UBC	1999
New	Approved Basic #99-100162BP	Rambler Style SFR - 1997 UBC	Plan#1:	1999
New	Approved Basic #98-1162BP		Plan 1200 Rambler Style SFR -	1999
New	Approved Basic #99-101802BP		Plan: 1450 S SFR w/finished basemei	1999
New	Approved Basic #98-116710BP		Plan: 1450 S SFR w/finished basement - 199	1999
New	Approved Basic #98-116234BP	SFR w/finished lower floor - 1997 UBC	Pl:	1999
New	Approved Basic #98-116234BP	SFR w/finished lower floor - 1997 UBC	Pl:	1999
New	Approved Basic #98-1162BP		Plan 1200 Rambler Style SFR - 1	1999
New	Rambler Style SFR - 1997 UBC		Plan: 60	1999
New	Approved Basic #99-100162BP	Rambler Style SFR - 1997 UBC	Plan#1340	1999
New	Approved Basic #98-1162BP		Plan 1200 Rambler Style SFR - 1	1999

Accessory Dwelling Units

Index # - File Name: 1.0022 - Single Family Dwellings Data\_Snohomish County.pdf

New	2 Story w/unfin basement & covered porch			1999
New	Approved Basic #98-108800BP	Plan 1861	Two Story SFR - 19	1999
New	Approved Basic #99-100162BP	Rambler Style SFR - 1997 UBC	Plan#1340	1999
New	Approved Basic #98-116238BP	Plan 1200	Rambler Style SFR	1999
New	Approved Basic #98-108800BP	Plan 1861	Two Story SFR - 19	1999
New	Approved Basic #99-102843BP	2-story SFR w/side-load 2-car attached garage.....1997 UBC	P	1999
New	2620 sf 2-story w/1282 sf garage and 102 sf covered deck/porch			1999
New	Duplex Rambler with attached garage - 1997 UBC			1999
New	Approved Basic #98-150505BP	Plan: 1771	Two Story SFR - 1997	1999
New	Approved Basic #98-106867BP	(4 Bedroom)	Two Story SFR - 1997 UBC	1999
New	Rambler SFR w/attached 2-car garage.....1997 UBC			1999
New	Approved Basic #98-110348BP	Plan #2005	Two Story SFR - 1997 U	1999
New	SFR w/Daylight basement & attached garage	REVISION TO PERMIT DATED 11/17/1998.		1999
New	2- Story Duplex - 1994 UBC			1999
New	Approved Basic #98-106458BP	Plan 1323	Two Story Duplex -	1999
New	Approved Basic #98-106458BP	Plan 1323	Two Story Duplex -	1999
New	Approved Basic #98-106458BP	Plan 1323	Two Story Duplex -	1999
New	Approved Basic #98-106458BP	Plan 1323	Two Story Duplex -	1999
New	Two Story SFR with Attached Garage			1999
New	Two-story SFR w/attached garage			1999
New	Approved Basic #98-106867BP	(4 Bedroom)	Two Story SFR - 1997 UBC	1999
New	Rambler Style SFR w/attached garage.	STOP WORK 10/12/99.-Mick	STOP WORK LIFTED 10/25,	1999
New	Approved Basic #98-150960BP	Two Story SFR - 1997 UBC	Plan: 2329	1999
New	Two Story SFR - 1997 UBC	Plan: 2203-3		1999
New	Approved Basic #99-104981BP	Plan: 2241	Two Story SFR - 1997 UB	1999
New	Two Story SFR - 1997 UBC	Plan: 2329-3		1999
New	2-Story Sfr w/attached garage.	1997-UBC		1999
New	Approved Basic #98-110337BP	Plan #2146 E	Two Story SFR with Att	1999
New	One-story SFR			1999
New	Two Story SFR - 1997 UBC	Plan: 2184		1999
New	Approved Basic #98-150960BP	Two Story SFR - 1997 UBC	Plan: 2329	1999
New	Two Story SFR - 1997 UBC	Plan: 2415 A/3		1999
New	Two-story SFR w/attached garage			1999
New	New 1452f, single story SFR with attached two car garage			1999
New	2-Story SFR w/attached garage.			1999
New	2-Story SFR w/attached garage.			1999
New	2-Story SFR w/attached garage.			1999
New	1999 Fleetwood 40 x 60			1999
New	1998 Lamplighter 28 x 66			1999
New	Two Story SFR w/unfinished basement - 1997 UBC			1999
New	Two Story SFR - 1997 UBC	Plan: #452		1999
New	Two Story SFR - 1997 UBC	Plan: #453		1999
New	Approved Basic #98-109999BP	Two Story SFR - 1997 UBC	Plan: #450	1999
New	Approved Basic #98-110000BP	Two Story SFR - 1997 UBC	Plan: #450	1999
New	Approved Basic #98-109999BP	Two Story SFR - 1997 UBC	Plan: #450	1999
New	Approved Basic #98-109999BP	Two Story SFR - 1997 UBC	Plan: #450	1999
New	2-story SFR w/attached 3-car garage.....1997 UBC			1999

Accessory Dwelling Units

Index # - File Name: 1.0022 - Single Family Dwellings Data\_Snohomish County.pdf

New	Rambler style SFR with attached garage		1999
New	1612 sf tri-level w/602 sf garage and 80 sf open deck		1999
New	1594 sf rambler w/528 sf garage and 24 sf covered deck/porch		1999
New	2-Story over Daylight basement & garage.		1999
New	27x52 with 13x 24 Bumpout	1999 Silvercrest	1999
New	Two Story SFR - 1997 UBC	Plan: 1938	1999
New	Approved Basic #98-150960BP	Two Story SFR - 1997 UBC	Plan: 2329 1999
New	2 Story SFR with attached garage - 1997 UBC		1999
New	2-story SFR w/attached garage.....1997 UBC		1999
New	Approved Basic #99-109481 BP	Plan: 2248 -3	Two Story SFR - 1997 UBC 1999
New	New 2415sf two story SFR with attached three car garage.		1999
New	New 2479sf two story home with attached two car garage.		1999
New	Approved Basic #99-109482 BP	Plan: 2288	Two Story SFR - 1997 UBC 1999
New	2-Story SFR w/attached garage.	1997-UBC	1999
New	Approved Basic #99-104981 BP	Two Story SFR - 1997 UBC	1999
New	Approved Basic #98-150960BP	Two Story SFR - 1997 UBC	Plan: 2329 1999
New	Two-story SFR w/attached garage		1999
New	Approved Basic #99-104368BP	Plan: 2241 C/3	Two Story SFR - 1997 1999
New	Approved Basic #98-150960BP	Two Story SFR - 1997 UBC	Plan: 2329 1999
New	Approved Basic #98-150960BP	Two Story SFR - 1997 UBC	Plan: 2329 1999
New	Approved Basic #98-150960BP	Two Story SFR - 1997 UBC	Plan: 2329 1999
New	Approved Basic #98-109999BP	Two Story SFR - 1997 UBC	Plan: #450 1999
New	Approved Basic #98-110000BP	Two Story SFR - 1997 UBC	Plan: #450 1999
New	Approved Basic #98-109999BP	Two Story SFR - 1997 UBC	Plan: #450 1999
New	Approved Basic #98-109999BP	Two Story SFR - 1997 UBC	Plan: #450 1999
New	Approved Basic #98-109999BP	Two Story SFR - 1997 UBC	Plan: #450 1999
New	Approved Basic #98-110000BP	Two Story SFR - 1997 UBC	Plan: #450 1999
New	Approved Basic #98-110000BP	Two Story SFR - 1997 UBC	Plan: #450 1999
New	Approved Basic #98-110000BP	Two Story SFR - 1997 UBC	Plan: #450 1999
New	Approved Basic #98-109998BP	Two Story SFR - 1997 UBC	Plan: #450 1999
New	Approved Basic #98-110000BP	Two Story SFR - 1997 UBC	Plan: #450 1999
New	Approved Basic #98-110000BP	Two Story SFR - 1997 UBC	Plan: #450 1999
New	Approved Basic #98-109999BP	Two Story SFR - 1997 UBC	Plan: #450 1999
New	Approved Basic #98-109999BP	Two Story SFR - 1997 UBC	Plan: #450 1999
New	Approved Basic #98-109999BP	Two Story SFR - 1997 UBC	Plan: #450 1999
New	Approved Basic #98-109999BP	Two Story SFR - 1997 UBC	Plan: #450 1999
New	Approved Basic #98-109999BP	Two Story SFR - 1997 UBC	Plan: #450 1999
New	Approved Basic #98-110000BP	Two Story SFR - 1997 UBC	Plan: #450 1999
New	Approved Basic #98-109999BP	Two Story SFR - 1997 UBC	Plan: #450 1999
New	Approved Basic #98-110000BP	Two Story SFR - 1997 UBC	Plan: #450 1999
New	Approved Basic #98-109999BP	Two Story SFR - 1997 UBC	Plan: #450 1999
New	Approved Basic #98-109999BP	Two Story SFR - 1997 UBC	Plan: #450 1999
New	Approved Basic #98-110000BP	Two Story SFR - 1997 UBC	Plan: #450 1999
New	Approved Basic #98-110000BP	Two Story SFR - 1997 UBC	Plan: #450 1999
New	Approved Basic #98-109999BP	Two Story SFR - 1997 UBC	Plan: #450 1999
New	Approved Basic #98-110000BP	Two Story SFR - 1997 UBC	Plan: #450 1999
New	Approved Basic #98-109999BP	Two Story SFR - 1997 UBC	Plan: #450 1999
New	Approved Basic #98-110000BP	Two Story SFR - 1997 UBC	Plan: #450 1999
New	Approved Basic #98-109999BP	Two Story SFR - 1997 UBC	Plan: #450 1999



Accessory Dwelling Units

Index # - File Name: 1.0022 - Single Family Dwellings Data\_Snohomish County.pdf

New	Approved Basic #98-109999BP	Two Story SFR - 1997 UBC	Plan: #450	1999
New	Approved Basic #98-109999BP	Two Story SFR - 1997 UBC	Plan: #450	1999
New	Approved Basic #98-110000BP	Two Story SFR - 1997 UBC	Plan: #450	1999
New	Approved Basic #98-109999BP	Two Story SFR - 1997 UBC	Plan: #450	1999
New	Approved Basic #98-109999BP	Two Story SFR - 1997 UBC	Plan: #450	1999
New	Approved Basic #98-109999BP	Two Story SFR - 1997 UBC	Plan: #450	1999
New	Approved Basic #98-110000BP	Two Story SFR - 1997 UBC	Plan: #450	1999
New	Approved Basic #98-109999BP	Two Story SFR - 1997 UBC	Plan: #450	1999
New	Approved Basic #98-109999BP	Two Story SFR - 1997 UBC	Plan: #450	1999
New	Approved Basic #98-109999BP	Two Story SFR - 1997 UBC	Plan: #450	1999
New	Approved Basic #98-110000BP	Two Story SFR - 1997 UBC	Plan: #450	1999
New	Approved Basic #98-109999BP	Two Story SFR - 1997 UBC	Plan: #450	1999
New	Approved Basic #98-109999BP	Two Story SFR - 1997 UBC	Plan: #450	1999
New	Approved Basic #98-110000BP	Two Story SFR - 1997 UBC	Plan: #450	1999
New	Approved Basic #98-109999BP	Two Story SFR - 1997 UBC	Plan: #450	1999
New	Approved Basic #98-109998BP	Two Story SFR - 1997 UBC	Plan: #450	1999
New	Approved Basic #98-110000BP	Two Story SFR - 1997 UBC	Plan: #450	1999
New	Approved Basic #98-109999BP	Two Story SFR - 1997 UBC	Plan: #450	1999
New	Approved Basic #98-109999BP	Two Story SFR - 1997 UBC	Plan: #450	1999
New	Approved Basic #98-109999BP	Two Story SFR - 1997 UBC	Plan: #450	1999
New	Approved Basic #98-109998BP	Two Story SFR - 1997 UBC	Plan: #450	1999
New	Approved Basic #98-109999BP	Two Story SFR - 1997 UBC	Plan: #450	1999
New	Approved Basic #98-110000BP	Two Story SFR - 1997 UBC	Plan: #450	1999
New	Approved Basic #98-109999BP	Two Story SFR - 1997 UBC	Plan: #450	1999
New	Approved Basic #98-109998BP	Two Story SFR - 1997 UBC	Plan: #450	1999
New	Approved Basic #98-110000BP	Two Story SFR - 1997 UBC	Plan: #450	1999
New	Approved Basic #98-109999BP	Two Story SFR - 1997 UBC	Plan: #450	1999
New	Approved Basic #98-110000BP	Two Story SFR - 1997 UBC	Plan: #450	1999
New	Approved Basic #98-109998BP	Two Story SFR - 1997 UBC	Plan: #450	1999
New	Approved Basic #98-110000BP	Two Story SFR - 1997 UBC	Plan: #450	1999
New	Approved Basic #98-109999BP	Two Story SFR - 1997 UBC	Plan: #450	1999
New	Approved Basic #98-110000BP	Two Story SFR - 1997 UBC	Plan: #450	1999
New	Approved Basic #98-109999BP	Two Story SFR - 1997 UBC	Plan: #450	1999
New	Approved Basic #98-110000BP	Two Story SFR - 1997 UBC	Plan: #450	1999
New	Approved Basic #98-109999BP	Two Story SFR - 1997 UBC	Plan: #450	1999
New	Approved Basic #98-110000BP	Two Story SFR - 1997 UBC	Plan: #450	1999
New	Approved Basic #98-109999BP	Two Story SFR - 1997 UBC	Plan: #450	1999
New	Approved Basic #98-110000BP	Two Story SFR - 1997 UBC	Plan: #450	1999
New	Approved Basic #98-110000BP	Two Story SFR - 1997 UBC	Plan: #450	1999
New	1999 27 x 56 Enchantment			1999
New	Approved Basic #99-115308 BP	Builder Plan 2453 Two-story SFR - 199		1999
New	Approved Basic #99-100619BP	Plan: 2553 Rambler Rambler Style SF		1999
New	Approved Basic #98-150628BP	Plan: 50 er Two Story SFR - 1997		1999
New	New 1999 28 x 66 Golden West MH			1999
New	28 X 64 Palm Harbor 1999			1999
New	Approved Basic #99-110432 BP	Plan: 52 er Two Story SFR - 199		1999
New	Two Story SFR - 1997 UBC	Plan: 2953		1999
New	Two-story SFR w/attached garage			1999

Accessory Dwelling Units

Index # - File Name: 1.0022 - Single Family Dwellings Data\_Snohomish County.pdf

New	Approved Basic #98-150985BP	Plan # 5911E	Two Story SFR - 1997 UBC	1999
New	New two story with attached three car garage.			1999
New	Approved Basic #98-150631BP	Plan: 47 er	Two Story SFR - 1997	1999
New	Rambler style SFR w/attached garage.			1999
New	Rambler Style SFR with attached garage			1999
New	Approved Basic #98-150974BP	Plan: Rambler w/bonus	Rambler Style	1999
New	Approved Basic #98-150630BP	Plan: Bielser	Two Story SFR - 199	1999
New	Approved Basic #99-109495 BP	Plan: 2771	Two Story SFR - 1997 U	1999
New	Approved Basic #98-150984BP	Plan: 5911-B	2844 sf 2-story with 682 sf ga	1999
New	2 Story w/3 Car			1999
New	1 story Rambler w/ 3 car garage			1999
New	Approved Basic #98-150628BP	Plan: 50 er	Two Story SFR - 1997	1999
New	Two Story SFR - 1997 UBC			1999
New	New 3067sf SFR with attached three car garage - 1997 UBC			1999
New	Approved Basic #98-150974BP	Plan: Rambler w/bonus	Rambler Style	1999
New	Approved Basic #99-109495 BP	Plan: 2771	Two Story SFR - 1997 U	1999
New	2 story SFR with attached garage			1999
New	2-story SFR w/attached 3-car garage....1997 UBC			1999
New	Two Story SFR with Attached Garage			1999
New	2 Story w/3 Car			1999
New	Approved Basic #99-109495 BP	Plan: 2771	Two Story SFR - 1997 U	1999
New	27 x 58 1999 Palm Harbor			1999
New	1999 26 8 x 44 Marlette			1999
New	1999 28 x 49 Palm Harbor			1999
New	1999 28 x 52 Goldenwest			1999
New	28x52 1999 Goldenwest			1999
New	27 X 50 Fleetwood 1999			1999
New	62 x 39 Silvercrest - Mobile Home			1999
New	1999 Palm Harbour 28 x 56			1999
New	New 1999 28 x 66 Golden West MH			1999
New	27 x 60 1999 Golden West			1999
New	27x48, 1999 Golden West			1999
New	1999 27 x 48 Palm Harbor			1999
New	28 x 52 1999 Goldenwest Mobile Home			1999
New	52x28, 2000 Goldenwest			1999
New	27 X 56 Fleetwood 1999			1999
New	1999 28 x 56 Superior			1999
New	1999 Palm Harbor 27 x 64			1999
New	28 x 60 1999 Palm Harbor Mobile Home			1999
New	28 x 48 Oakwood DW MH in Park			1999
New	28 x 66 1999 Palm Harbor			1999
New	27 -6 x 66 - 1999 - Wynnewood 366A - Mobile Home.			1999
New	1999 48 x 27 GoldenWest			1999
New	1999 40 x 46			1999
New	1999 Silvercrest EO-31 56 x 40			1999
New	1999 Golden West 27 x 52			1999
New	2000 28 x 66 Redman			1999

Accessory Dwelling Units

Index # - File Name: 1.0022 - Single Family Dwellings Data\_Snohomish County.pdf

New	40 x 60 - 1999 - Redman - Mobile Home.		1999
New	2000 Goldenwest in MH Park		1999
New	2-Story SFR with attached garage and covered porch - 1997 UBC		1999
New	Two-story SFR w/attached garage		1999
New	2 Story w/3 Car		1999
New	2 Story w/3 Car		1999
New	Approved Basic #99-105206BP	Plan: 2934 Two Story SFR - 1997	1999
New	Approved Basic #99-115544 BP	Builders Plan C090895 Two-story SFR - 1997 UBC	1999
New	Approved Basic #98-150751BP	Plan: #2008 Rambler style SFR with at	1999
New	Approved Basic #98-150750BP	Plan: #2067 Rambler style SFR with attac	1999
New	Rambler with Attaced Garage - 1997 UBC		1999
New	2 story sfr w/3 car garage		1999
New	Approved Basic #99-101606BP	Plan #2207 Two Story SFR - 1997 UB	1999
New	2 Story w/2 Car		1999
New	2 Story w/2 Car		1999
New	2 story sfr w/3 car garage		1999
New	Approved Basic #99-115457 BP	Plan: 2203 Ashton Two Story SFR - 1997 UI	1999
New	Approved Basic #99-109416BP	Builders Plan 2321 Rambler Style SFR- 1	1999
New	SFR with Attached Garage - 1997 UBC		1999
New	Approved Basic #98-150984BP	Plan: 5911-B Two Story SFR - 1997 UBC	1999
New	Two Story SFR - 1997 UBC	Plan: 2020-B	1999
New	Approved Basic #98-150985BP	Plan # 5911E Two Story SFR - 1997 UBC	1999
New	Approved Basic #99-113246 BP	Plan: 2632 Two Story SFR - 1997 UB	1999
New	Two Story SFR - 1997 UBC	Plan: Brosueau	1999
New	2 story SFR with attached garage		1999
New	3038 sf 2-story w/682 sf garage and 303 sf covered deck/porch		1999
New	3207 sf 2-story w/772 sf garage and 549 sf covered deck/porch		1999
New	Approved Basic #99-109416BP	Builders Plan 2321 Rambler Style SFR- 1	1999
New	One-story SFR w/attached garage		1999
New	Two Story SFR - 1997 UBC	Plan #44 er	1999
New	Approved Basic #98-150974BP	Plan: Rambler w/bonus Rambler Style S	1999
New	Two Story SFR - 1997 UBC	Plan: 47 er	1999
New	2-Story Duplex w/attached One Two Bedroom Unit and One One Bedroom Unit		1999
New	Two-story duplex w/attached garage - 1997 UBC		1999
New	1999 Golden West 40 x 66		1999
New	66 x 40 1999 Fleetwood Waverly Crest		1999
New	28x52 (1999) Goldenwest		1999
New	27 X 60 Fleetwood 1999		1999
New	1999 Palm Harbor 1057 Double Wide Mobile Home 27 x 56		1999
New	New triple wide		1999
New	27 x 44 - 1998 Oakwood		1999
New	28 x 52 1999 Goldenwest Mobile Home		1999
New	28x66, 1999 Lamplighter		1999
New	1998, 27x 60 ft MH		1999
New	28x66 (1999) Goldenwest		1999
New	28 x 64 Palm Harbor (1998)		1999
New	28 x 66 - 1999 - Golden West Mobile Home.		1999

Accessory Dwelling Units

Index # - File Name: 1.0022 - Single Family Dwellings Data\_Snohomish County.pdf

New	28 X 56 Lamplighter	1999	
New	28 x 48 Palm Harbor (1998)	1999	
New	66 X 27 1999 Palm Harbor	1999	
New	27 X 66 1998 Oakwood	1999	
New	27x66 (1998) Goldenwest	1999	
New	1999 40x 48ft Double wide MH in MH park	1999	
New	41 x 56 1999 Goldenwest MH	1999	
New	New 1999 Oakwood	1999	
New	27 x 64 1999 Doublewide Palm Harbor	1999	
New	1998, 28 x 66 doublewide marlette MH	1999	
New	27 X 48 1998 Oakwood	1999	
New	25x52, 1998 Fleetwood	1999	
New	27x48, 1999 Goldenwest	1999	
New	New 1999, 28 x 66ft, Oakwood Doublewide.	1999	
New	1998 28 x 52 Kit	1999	
New	28x48, 1999 Palm Harbor	1999	
New	28 x 56 Double Wide MH - 1999 Fleetwood	1999	
New	27x48 1999 Palm Harbor Mobile Home	1999	
New	27x57 1999 Palm Harbor Mobile Home	1999	
New	1998, 28 x 57 Palm Harbor MH	1999	
New	28 x 52 Marlette MH	1999	
New	28 x 48 1999 Oakwood Goldenwest Mobile Home....1997 UBC	1999	
New	27 x 64 - 1999 - Palm Harbor 464	1999	
New	27 X 50 Champion 1999	1999	
New	27 x 69 Palm Harbor Mobile Home	1999	
New	28x66, 1998 Palm Harbor	1999	
New	27 x 56 1999 Palm Harbor	1999	
New	1999 28 x 52 GoldenWest	1999	
New	28 x 58 Palm Harbor Mobile Home	1999	
New	28x66 (1998) Goldenwest	1999	
New	28 x 64 Palm Harbor (1998)	1999	
New	Approved Basic #98-150630BP	Plan: Bielser Two Story SFR - 1997 UBC	1999
New	Approved Basic #98-110516BP	Two Story SFR - 1997 UBC	Plan: 24 1999
New	2-Story SFR w/attached garage.		1999
New	Approved Basic #98-150630BP	Plan: Bielser Two Story SFR - 1997 UBC	1999
New	Approved Basic #98-150974BP	Plan: Rambler w/ bonus Rambler Style SF	1999
New	Two Story SFR - 1997 UBC	Plan: 45 er	1999
New	Approved Basic #98-150489BP	Builders Plan #1500 Split level with attach	1999
New	2 Story w/3 Car		1999
New	2 story SFR with attached garage		1999
New	2 story SFR with attached garage		1999
New	2 Story w/3 Car		1999
New	2-Story SFR w/attached garage.		1999
New	Approved Basic #98-150628BP	Plan: 50 er Two Story SFR - 1997 UBC	1999
New	Approved Basic #98-150984BP	Plan: 5911-B Two Story SFR - 1997 UBC	1999
New	Approved Basic #98-150974BP	Plan: Rambler w/bonus Rambler St	1999
New	SFR Rambler		1999

Accessory Dwelling Units

Index # - File Name: 1.0022 - Single Family Dwellings Data\_Snohomish County.pdf

New	Two Story SFR - 1997 UBC	Plan: 1063	1999
New	3065 sf 2-story w/804 sf garage and 24 sf covered porch		1999
New	2 Story w/3 Car		1999
New	2 Story w/3 Car		1999
New	1-Story SFR with attached garage		1999
New	2-story SFR w/attached 3-car garage.....1997 UBC		1999
New	2 Story w/3 Car		1999
New	Two Story SFR - 1997 UBC		1999
New	Two Story SFR - 1997 UBC		1999
New	2 Story W/3 Car		1999
New	Approved Basic #99-109906 BP Two Story SFR - 1997 UBC		1999
New	Two-story Cabin		1999
New	Rambler with attached garage - 1997 UBC		1999
New	14 X 60 Homette 1982		1999
New	Approved Basic #98-110231BP	Plan: Rutledge 1365 One-story SFF	1999
New	Rambler with attached garage - 1997 UBC		1999
New	2 Story SFR w/ attached garage		1999
New	2 story sfr w/2 car garage		1999
New	14x70, 1978 Marlette.		1999
New	Duplex with attached garage - 1997 UBC		1999
New	Duplex with attached garage - 1997 UBC		1999
New	Approved Basic #99-110432 BP	Plan: 52 er Two Story SFR - 199	1999
New	Approved Basic #98-150974BP	Plan: Rambler w/bonus Rambler Style	1999
New	Approved Basic #98-150974BP	Plan: Rambler w/bonus Rambler Style S	1999
New	Approved Basic #98-110516BP Two Story SFR - 1997 UBC	Plan: 24	1999
New	Approved Basic #98-150628BP	Plan: 50 er Two Story SFR - 1997	1999
New	Approved Basic #98-108803BP	Plan 1750 Cal 1174 sf SFR w/56	1999
New	Approved Basic #98-108806BP	Plan 1936 Split 1174 sf SFR w/762 sf ur	1999
New	Approved Basic #98-108803BP	Plan 1750 Cal 1174 sf SFR w/56	1999
New	Approved Basic #98-108803BP	Plan 1750 Cal 1174 sf SFR w/56	1999
New	Approved Basic #98-108806BP	Plan 1936 Split 1174 sf SFR w/762 sf ur	1999
New	Approved Basic #98-108803BP	Plan 1750 Cal 1174 sf SFR w/56	1999
New	Approved Basic #98-108806BP	Plan 1936 Split 1174 sf SFR w/762 sf ur	1999
New	Approved Basic #98-108803BP	Plan 1750 Cal 1174 sf SFR w/56	1999
New	1991 28 x 56 Fleetwood Berkshire		1999
New	Rambler style SFR with attached garage		1999
New	1437 s.f. rambler with 2 car garage		1999
New	3426 sf 2-story w/707 sf garage and 392 sf covered deck/porch		1999
New	3225 sf 2-story w/830 sf garage		1999
New	Approved Basic #98-108803BP	Plan 1750 Cal 1174 sf SFR w/56	1999
New	Approved Basic #98-108806BP	Plan 1936 Split 1174 sf SFR w/762 sf ur	1999
New	Approved Basic #98-108803BP	Plan 1750 Cal 1174 sf SFR w/56	1999
New	Approved Basic #98-108806BP	Plan 1936 Split 1174 sf SFR w/762 sf ur	1999
New	Approved Basic #98-108806BP	Plan 1936 Split 1174 sf SFR w/762 sf ur	1999
New	Approved Basic #98-108803BP	Plan 1750 Cal 1174 sf SFR w/56	1999

Accessory Dwelling Units

Index # - File Name: 1.0022 - Single Family Dwellings Data\_Snohomish County.pdf

New	Approved Basic #98-108806BP	Plan 1936 Split	1174 sf SFR w/762 sf ur	1999
New	Approved Basic #98-108803BP	Plan 1750 Cal	1174 sf SFR w/56	1999
New	Approved Basic #98-108806BP	Plan 1936 Split	1174 sf SFR w/762 sf ur	1999
New	Approved Basic #98-108803BP	Plan 1750 Cal	1174 sf SFR w/56	1999
New	Approved Basic #98-108806BP	Plan 1936 Split	1174 sf SFR w/762 sf ur	1999
New	Approved Basic #98-108806BP	Plan 1936 Split	1174 sf SFR w/762 sf ur	1999
New	Approved Basic #98-108806BP	Plan 1936 Split	1174 sf SFR w/762 sf ur	1999
New	Approved Basic #98-108803BP	Plan 1750 Cal	1174 sf SFR w/56	1999
New	Approved Basic #98-108806BP	Plan 1936 Split	1174 sf SFR w/762 sf ur	1999
New	Approved Basic #98-108803BP	Plan 1750 Cal	1174 sf SFR w/56	1999
New	Approved Basic #98-108803BP	Plan 1750 Cal	1174 sf SFR w/56	1999
New	Approved Basic #98-108806BP	Plan 1936 Split	1174 sf SFR w/762 sf ur	1999
New	Approved Basic #98-108803BP	Plan 1750 Cal	1174 sf SFR w/56	1999
New	Approved Basic #98-108803BP	Plan 1750 Cal	1174 sf SFR w/56	1999
New	Approved Basic #98-108806BP	Plan 1936 Split	1174 sf SFR w/762 sf ur	1999
New	Approved Basic #98-108806BP	Plan 1936 Split	1174 sf SFR w/762 sf ur	1999
New	Approved Basic #98-108803BP	Plan 1750 Cal	1174 sf SFR w/56	1999
New	Approved Basic #98-108806BP	Plan 1936 Split	1174 sf SFR w/762 sf ur	1999
New	Approved Basic #98-108803BP	Plan 1750 Cal	1174 sf SFR w/56	1999
New	Approved Basic #98-108803BP	Plan 1750 Cal	1174 sf SFR w/56	1999
New	Approved Basic #98-108806BP	Plan 1936 Split	1174 sf SFR w/762 sf ur	1999
New	Approved Basic #98-108806BP	Plan 1936 Split	1174 sf SFR w/762 sf ur	1999
New	Approved Basic #98-108803BP	Plan 1750 Cal	1174 sf SFR w/56	1999
New	Approved Basic #98-108806BP	Plan 1936 Split	1174 sf SFR w/762 sf ur	1999
New	Approved Basic #98-150943BP	Plan: 1821	Two Story SFR - 1997 UB	1999
New	Approved Basic #98-150943BP	Plan: 1821	Two Story SFR - 1997 UB	1999
New	40 x 60 - 1999 - Fleetwood		-Mobile Home.	1999
New	Rambler w/2 Car			1999
New	Approved Basic 99-110667 BP	2 story sfr with 2 car garage	Plan: 18	1999
New	Approved Basic #98-150943BP	Plan: 1821	Two Story SFR - 1997 UB	1999
New	Approved Basic #98-150696BP	Plan: 1922	Two Story SFR - 1997 UBC	1999
New	2-Story SFR w/attached garage			1999
New	Approved Basic #98-150696BP	Plan: 1922	Two Story SFR - 1997 UBC	1999
New	Approved Basic #98-150705BP	Plan: 1862	Two Story SFR - 1997 UBC	1999
New	Approved Basic #98-150943BP	Plan: 1821	Two Story SFR - 1997 UB	1999
New	Approved Basic #98-150705BP	Plan: 1862	Two Story SFR - 1997 UBC	1999
New	2 story SFR w/ attached 3 car garage			1999
New	2 Story SFR with covered entry porch and attached garage - 1997 UBC			1999
New	New 2516sf SFR with attached three car garage			1999
New	2 Story SFR with attached garage and covered entry - 1997 UBC			1999
New	2-Story SFR with attached garage - 1997 UBC			1999
New	Approved Basic #99-102391BP	Plan: Hillwood	SFR w/finished basement -	1999
New	1124 sf main floor w/486 sf finished basement, 576 sf garage and 28 sf covered deck/porch			1999
New	Approved Basic #98-110222BP	Two-story Duplex - 1997 UBC		1999
New	Rambler Style SFR - 1997 UBC	Plan: Cheyenne		1999

Accessory Dwelling Units

Index # - File Name: 1.0022 - Single Family Dwellings Data\_Snohomish County.pdf

New	Rambler Style SFR - 1997 UBC	Plan: 2200 Rambler Chelan	1999
New	Two Story SFR - 1997 UBC	Plan: 2455/3	1999
New	Approved Basic #98-150795BP	Plan: 2776 (Walton) Two Story SFR	1999
New	Approved Basic #99-109631 BP	Plan: Holly Two Story SFR - 1997 UE	1999
New	Approved Basic #99-109631 BP	Plan: Holly Two Story SFR - 1997 UE	1999
New	Approved Basic #99-109631 BP	Plan: Holly Two Story SFR - 1997 UE	1999
New	Approved Basic #99-109630 BP	Plan: Laurel Two Story SFR - 1997 UB	1999
New	Approved Basic #99-109631 BP	Plan: Holly Two Story SFR - 1997 UE	1999
New	Approved Basic #99-109630 BP	Plan: Laurel Two Story SFR - 1997 UB	1999
New	Approved Basic #99-109631 BP	Plan: Holly Two Story SFR - 1997 UE	1999
New	Approved Basic #98-116672BP	Plan: P-100297 One-story SFR w/finis	1999
New	Approved Basic #98-116672BP	Plan: P-100297 One-story SFR w/fin	1999
New	New two story, two car, SFR(1484sf)		1999
New	Approved Basic #99-102547BP	Plan: 1484 Two Story SFR - 1997 UBC	1999
New	Approved Basic #99-102547BP Two Story SFR with Attached Garage	Plan 1484	1999
New	1167 sf SFR w/486 sf finished basement; 552 sf garage; and 28 sf covered deck/porch		1999
New	Approved Basic #99-101118BP SFR w/ 2 car garage w/ optional storage area		1999
New	Approved Basic #99-101118BP SFR w/ 2 car garage w/ optional storage area		1999
New	Approved Basic #99-101118BP SFR w/ 2 car garage w/ optional storage area		1999
New	New 3,120sf, two story SFR with attached three car garage.		1999
New	Two Story SFR with Finished Basement and Attached Garage		1999
New	Approved Basic #99-101510BP	Builder Plan # 7840 Two Story SFR with A	1999
New	One-story SFR w/finished basement.		1999
New	2-story SFR w/attached 3-car garage.....1997 UBC	REINSPECTION FEE NOT PAID BECAUSE CUST	1999
New	Two-story SFR w/attached garage		1999
New	Two-story SFR w/attached garage		1999
New	2-story SFR w/attached 3-car garage....1997 UBC		1999
New	Two Story SFR - 1997 UBC	Plan #1938 A	1999
New	2-Story SFR w/attached garage - 1997 UBC		1999
New	2 story with attached garage --1997 UBC		1999
New	2-Story SFR w/attached garage - 1997 UBC		1999
New	2042 sf rambler w/864 sf garage and 142 sf covered deck/porch		1999
New	*Issued under tax roll # 005690-000-051-01* New duplex with two attached two car garages.		1999
New	Approved Basic #98-110504BP	Plan #2195 Split Level SFR - 1997 UBC	1999
New	Approved Basic #98-110504BP	Plan #2195 Split Level SFR - 1997 UBC	1999
New	Approved Basic #98-102233 BP	BUILDERS NO. 2226 2 Story SFR with att	1999
New	2 story sfr with 3 car garage		1999
New	Rambler w/attached 3-car garage.....1997 UBC		1999
New	Approved Basic #98-102233 BP	BUILDERS NO. 2226 2 Story SFR with att	1999
New	2 story SFR w/attached 3-car garage....1997 UBC		1999
New	Approved Basic 99-101299BP	Plan: #10 Mid-Entry With 2 Car - 1997 UI	1999
New	Approved Basic 99-101299BP	Plan: #10 Mid-Entry With 2 Car - 1997 UI	1999
New	2 story SFR w/ attached garage		1999
New	28x56 1999 Redman		1999
New	Two Story SFR - 1997 UBC		1999
New	Approved Basic #99-101442BP	BUILDERS NO M1974A2F-0 2 Story SF	1999
New	Approved Basic #99-101446BP Two-story SFR w/attache garage - 1997 UBC	Plan PLAN	1999

Accessory Dwelling Units

Index # - File Name: 1.0022 - Single Family Dwellings Data\_Snohomish County.pdf

New	Approved Basic #99-101442BP	Plan: 1974 A	2 Story SFR with attach	1999
New	Two-story SFR w/attache garage - 1997 UBC	Plan	PLAN M1974B2F-0	1999
New	Approved Basic #99-101442BP	Plan: 1974 A	2 Story SFR with attach	1999
New	Approved Basic #99-104379-BP	Plan: 1998A/2	Two Story SFR w/attach	1999
New	Approved Basic #99-104379-BP	Plan: 1998A/2	Two Story SFR w/attach	1999
New	Approved Basic #99-101446BP	Two-story SFR w/attache garage - 1997 UBC	Plan: 1974	1999
New	Two-story SFR w/attache garage - 1997 UBC	Plan: M1974 A2F-0		1999
New	Approved Basic #99-101446BP	Two-story SFR w/attache garage - 1997 UBC	Plan: 1974	1999
New	Approved Basic #99-101442BP	Plan: 1974 A	2 Story SFR with attach	1999
New	Approved Basic #99-104379-BP	Plan: 1998A/2	Two Story SFR w/attach	1999
New	2-Story SFR w/attached garage.			1999
New	2-Story SFR w/attached garage.			1999
New	Approved Basic #99-101683BP	SFR w/finshed basement - 1997 UBC		1999
New	14x70, 1980 Hillcrest			1999
New	Approved Basic #98-108803BP	Plan 1750 Cal	1174 sf SFR w/56	1999
New	Mid-entry w/attache 2-car garage.....1997 UBC	Plan: 1491		1999
New	Approved Basic #98-109885BP	Two Story SFR - 1997 UBC	Plan: #299	1999
New	Approved Basic #98-109885BP	Two Story SFR - 1997 UBC	Plan: #299	1999
New	Approved Basic #98-110372BP	Two Story SFR - 1997 UBC	Plan: #257	1999
New	Approved Basic #98-110372BP	Two Story SFR - 1997 UBC	Plan: #257	1999
New	Two Story SFR w/attached garage.			1999
New	Approved Basic #98-109885BP	Two Story SFR - 1997 UBC	Plan: #299	1999
New	Approved Basic #98-109885BP	Two Story SFR - 1997 UBC	Plan: #299	1999
New	Approved Basic #99-110099 BP	Plan: #2148 Elev A	Two Story SFR - 1997	1999
New	Approved Basic #98-110372BP	Two Story SFR - 1997 UBC	Plan: #257	1999
New	Approved Basic #98-109883BP	Two Story SFR - 1997 UBC	Plan: #244	1999
New	Approved Basic #98-108806BP	Plan 1936 Split	1174 sf SFR w/762 sf ur	1999
New	Approved Basic #98-108803BP	Plan 1750 Cal	1174 sf SFR w/56	1999
New	Approved Basic #98-108806BP	Plan 1936 Split	1174 sf SFR w/762 sf ur	1999
New	Approved Basic #98-108803BP	Plan 1750 Cal	1174 sf SFR w/56	1999
New	Approved Basic #98-108806BP	Plan 1936 Split	1174 sf SFR w/762 sf ur	1999
New	Approved Basic #98-108803BP	Plan 1750 Cal	1174 sf SFR w/56	1999
New	Approved Basic #98-108806BP	Plan 1936 Split	1174 sf SFR w/762 sf ur	1999
New	Approved Basic #98-108803BP	Plan 1750 Cal	1174 sf SFR w/56	1999
New	Approved Basic #98-108806BP	Plan 1936 Split	1174 sf SFR w/762 sf ur	1999
New	Approved Basic #98-108803BP	Plan 1750 Cal	1174 sf SFR w/56	1999
New	Approved Basic #98-108806BP	Plan 1936 Split	1174 sf SFR w/762 sf ur	1999
New	Approved Basic #98-108803BP	Plan 1750 Cal	1174 sf SFR w/56	1999
New	Approved Basic #98-108806BP	Plan 1936 Split	1174 sf SFR w/762 sf ur	1999
New	Approved Basic #98-108803BP	Plan 1750 Cal	1174 sf SFR w/56	1999
New	Approved Basic #98-108806BP	Plan 1936 Split	1174 sf SFR w/762 sf ur	1999
New	Approved Basic #98-108803BP	Plan 1750 Cal	1174 sf SFR w/56	1999
New	Approved Basic #98-108806BP	Plan 1936 Split	1174 sf SFR w/762 sf ur	1999
New	Approved Basic #98-108803BP	Plan 1750 Cal	1174 sf SFR w/56	1999
New	Approved Basic #98-108806BP	Plan 1936 Split	1174 sf SFR w/762 sf ur	1999



Accessory Dwelling Units

Index # - File Name: 1.0022 - Single Family Dwellings Data\_Snohomish County.pdf

New	Approved Basic #98-108803BP	Plan 1750 Cal	1174 sf SFR w/56	1999
New	Approved Basic #98-108806BP	Plan 1936 Split	1174 sf SFR w/762 sf ur	1999
New	Approved Basic #98-108806BP	Plan 1936 Split	1174 sf SFR w/762 sf ur	1999
New	Approved Basic #98-108803BP	Plan 1750 Cal	1174 sf SFR w/56	1999
New	Approved Basic #98-108806BP	Plan 1936 Split	1174 sf SFR w/762 sf ur	1999
New	Approved Basic #98-108803BP	Plan 1750 Cal	1174 sf SFR w/56	1999
New	Approved Basic #98-108806BP	Plan 1936 Split	1174 sf SFR w/762 sf ur	1999
New	Approved Basic #98-108803BP	Plan 1750 Cal	1174 sf SFR w/56	1999
New	Approved Basic #98-108806BP	Plan 1936 Split	1174 sf SFR w/762 sf ur	1999
New	Approved Basic #98-108803BP	Plan 1750 Cal	1174 sf SFR w/56	1999
New	Approved Basic #98-108806BP	Plan 1936 Split	1174 sf SFR w/762 sf ur	1999
New	Approved Basic #98-108803BP	Plan 1750 Cal	1174 sf SFR w/56	1999
New	Approved Basic #98-108806BP	Plan 1936 Split	1174 sf SFR w/762 sf ur	1999
New	Approved Basic #98-108803BP	Plan 1750 Cal	1174 sf SFR w/56	1999
New	Approved Basic #98-108806BP	Plan 1936 Split	1174 sf SFR w/762 sf ur	1999
New	Approved Basic #98-108803BP	Plan 1750 Cal	1174 sf SFR w/56	1999
New	Approved Basic #98-108806BP	Plan 1936 Split	1174 sf SFR w/762 sf ur	1999
New	Approved Basic #98-108803BP	Plan 1750 Cal	1174 sf SFR w/56	1999
New	Approved Basic #98-108806BP	Plan 1936 Split	1174 sf SFR w/762 sf ur	1999
New	Approved Basic #98-108803BP	Plan 1750 Cal	1174 sf SFR w/56	1999
New	Approved Basic #98-108806BP	Plan 1936 Split	1174 sf SFR w/762 sf ur	1999
New	Approved Basic #98-108803BP	Plan 1750 Cal	1174 sf SFR w/56	1999
New	Approved Basic #98-108806BP	Plan 1936 Split	1174 sf SFR w/762 sf ur	1999
New	Approved Basic #98-108803BP	Plan 1750 Cal	1174 sf SFR w/56	1999
New	Approved Basic #98-108806BP	Plan 1936 Split	1174 sf SFR w/762 sf ur	1999
New	Approved Basic #98-108803BP	Plan 1750 Cal	1174 sf SFR w/56	1999
New	Approved Basic #98-108806BP	Plan 1936 Split	1174 sf SFR w/762 sf ur	1999
New	Approved Basic #98-108803BP	Plan 1750 Cal	1174 sf SFR w/56	1999
New	Approved Basic #98-108806BP	Plan 1936 Split	1174 sf SFR w/762 sf ur	1999
New	Approved Basic #98-108803BP	Plan 1750 Cal	1174 sf SFR w/56	1999
New	Approved Basic #98-108806BP	Plan 1936 Split	1174 sf SFR w/762 sf ur	1999
New	Approved Basic #98-108803BP	Plan 1750 Cal	1174 sf SFR w/56	1999
New	Approved Basic #98-108806BP	Plan 1936 Split	1174 sf SFR w/762 sf ur	1999
New	2-story SFR w/attached 2-car garage.....1997 UBC	Plan: 1650		1999
New	Approved Basic #99-105262-BP	2-Story SFR w/attached garage - 1997 UBC	b	1999
New	Builders Plan #1491	Mid Entry w/Finished Basement & 2 Car		1999
New	Approved Basic #99-103945BP	Mid-entry home w/attached 2-car garage....1997 UBC	Build	1999
New	Builders Plan #1650	2 Story w/2 Car		1999
New	Approved Basic #99-105262-BP	2-Story SFR w/attached garage 1997 UBC	bldr. plan	1999
New	Approved Basic #99-105263BP	Plan: 1200	Mid entry SFR - 1997 UBC	1999
New	Approved Basic #99-105266BP	Plan: 1650	Mid Entry SFR - 1997 UBC	1999
New	Approved Basic #99-105262-BP	2-Story SFR w/attached garage 1997 UBC	bldr. plan	1999
New	Mid-entry w/attached 2-car garage.....1997 UBC	Plan: 1200		1999
New	Approved Basic #99-103945BP	Mid-entry home w/attached 2-car garage....1997 UBC	Build	1999
New	Split level SFR with attached garage - 1997 UBC			1999
New	Approved Basic #99-103945BP	Mid-entry home w/attached 2-car garage....1997 UBC	Build	1999
New	Split level SFR with attached garage - 1997 UBC			1999

Accessory Dwelling Units

Index # - File Name: 1.0022 - Single Family Dwellings Data\_Snohomish County.pdf

New	Two Story SFR - 1997 UBC	Plan: 2717/A	1999
New	2 story sfr w/3 car garage	PLAN #1A	1999
New	Approved Basic #99-114320 BP	Plan: 2C Rambler Style SFR - 199	1999
New	Rambler w/covered porch		1999
New	Two Story SFR - 1997 UBC		1999
New	Approved Basic #99-109807 BP	Plan: 2768 Two Story SFR - 1997 UBC	1999
New	Approved Basic #99-115337 BP	Plan: 2C Rambler Style SFR - 199	1999
New	2 Story w/3Car	Builders Plan 3	1999
New	Two Story SFR - 1997 UBC		1999
New	Two Story SFR - 1997 UBC	Plan: #2990 Elev. A,B,C	1999
New	Two Story SFR - 1997 UBC	Plan: #2148 Elev. A,B,C	1999
New	Approved Basic #99-109955 BP	Plan: 2148 Elev. B Two Story SFR - 1997	1999
New	Approved Basic #98-109884BP	Two Story SFR -1997 UBC	Plan: #255 1999
New	Two Story SFR - 1997 UBC		1999
New	Two Story SFR - 1997 UBC	Plan: 2592 Elev. C	1999
New	Approved Basic #98-110372BP	Two Story SFR - 1997 UBC	Plan: #257 1999
New	Two Story SFR - 1997 UBC	Plan: #2575 Elev. A,B,C	1999
New	Two Story SFR - 1997 UBC	Plan: #2747	1999
New	Approved Basic #98-109885BP	Two Story SFR - 1997 UBC	Plan: #299 1999
New	Approved Basic #99-103307BP	Plan: 2747 - Elevation C Two Story SFR	1999
New	Approved Basic #99-110098 BP	Two Story SFR - 1997 UBC	Plan: #21 1999
New	Approved Basic #99-103251BP	Plan: 2747 - Elevation A Two Story SFR	1999
New	Approved Basic #98-110372BP	Two Story SFR - 1997 UBC	Plan: #257 1999
New	Approved Basic #98-109885BP	Two Story SFR - 1997 UBC	Plan: #299 1999
New	Approved Basic #98-110372BP	Two Story SFR - 1997 UBC	Plan: #257 1999
New	Approved Basic #98-109883BP	Two Story SFR - 1997 UBC	Plan: #244 1999
New	Approved Basic #98-109883BP	Two Story SFR - 1997 UBC	Plan: #244 1999
New	Approved Basic #98-110372BP	Two Story SFR - 1997 UBC	Plan: #257 1999
New	Approved Basic #99-103307BP	Plan: 2747 - Elevation C Two Story SFR	1999
New	Approved Basic #98-110372BP	Two Story SFR - 1997 UBC	Plan: #257 1999
New	Approved Basic #98-109883BP	Two Story SFR - 1997 UBC	Plan: #244 1999
New	Approved Basic #98-109885BP	Two Story SFR - 1997 UBC	Plan: #299 1999
New	Two Story SFR - 1997 UBC	Plan: #2446 Elev. A,B,C	1999
New	Approved Basic #98-109885BP	Two Story SFR - 1997 UBC	Plan: #299 1999
New	Approved Basic #98-109885BP	Two Story SFR - 1997 UBC	Plan: #299 1999
New	Approved Basic #98-109883BP	Two Story SFR - 1997 UBC	Plan: #244 1999
New	Approved Basic #98-109883BP	Two Story SFR - 1997 UBC	Plan: #244 1999
New	Approved Basic #98-110372BP	Two Story SFR - 1997 UBC	Plan: #257 1999
New	Approved Basic #99-109806 BP	Plan: 2628 Two Story SFR - 1997 UBC	1999
New	Approved Basic #99-110402 BP	Two Story SFR - 1997 UBC	Plan: 236 1999
New	Approved Basic #99-109807 BP	Plan: 2768 Two Story SFR - 1997 UBC	1999
New	Approved Basic #99-109806 BP	Plan: 2628 Two Story SFR - 1997 UBC	1999
New	Two Story SFR - 1997 UBC		1999
New	Approved Basic #99-109807 BP	Plan: 2768 Two Story SFR - 1997 UBC	1999
New	Two Story SFR - 1997 UBC	Plan: 2717/A	1999
New	Two Story SFR - 1997 UBC	Plan: 2481/B	1999
New	Two Story SFR - 1997 UBC	Plan: 2606/A	1999

Accessory Dwelling Units

Index # - File Name: 1.0022 - Single Family Dwellings Data\_Snohomish County.pdf

New	Two Story SFR - 1997 UBC	Plan: 2838/A	1999
New	Two Story SFR - 1997 UBC	Plan: 2717/B	1999
New	Two Story SFR - 1997 UBC	Plan: 2838/B	1999
New	Two Story SFR - 1997 UBC	Plan: 2717/A	1999
New	Two Story SFR - 1997 UBC	Plan: 2606/B	1999
New	Two Story SFR - 1997 UBC	Plan: 2717/B	1999
New	Two Story SFR - 1997 UBC	Plan: 2838/A	1999
New	Two Story SFR - 1997 UBC	Plan: 2606/A	1999
New	Approved Basic #99-115246 BP	Plan: 2717 A Two Story SFR - 1997 U	1999
New	Two Story SFR - 1997 UBC	Plan: 2481 A	1999
New	2 story sfr w/2 car garage		1999
New	2 story SFR with attached garage		1999
New	Approved Basic #99-113027BP	2 story SFR with attached garage	1999
New	2 story sfr with 3 car garage		1999
New	Two Story SFR - 1997 UBC	Plan: 2621	1999
New	Two Story SFR - 1997 UBC	Plan: 2367	1999
New	Two Story SFR - 1997 UBC	Plan: 2628	1999
New	Two Story SFR - 1997 UBC	Plan: 2768	1999
New	Approved Basic #98-109883BP	Two Story SFR - 1997 UBC	Plan: #244 1999
New	2068 sf rambler w/671 sf garage and 108 sf covered deck/porch		1999
New	Approved Basic #98-110372BP	Two Story SFR - 1997 UBC	Plan: #257 1999
New	Approved Basic #99-115034 BP	Plan: 3319 Elev B Two Story SFR - 1997	1999
New	Approved Basic #98-109883BP	Two Story SFR - 1997 UBC	Plan: #244 1999
New	Approved Basic #98-109885BP	OPTION: Approved TJI Two Story SFR - 1997 UBC	1999
New	2-story SFR w/attached 2-car garage...1997 UBC		1999
New	Approved Basic #98-110372BP	Two Story SFR - 1997 UBC	Plan: #257 1999
New	Approved Basic #99-110537 BP	Plan: 2576 Two Story SFR - 1997 UB	1999
New	Approved Basic #99-110534 BP	Plan: 2528 Two Story SFR - 1997 UBC	1999
New	2-story SFR w/attached 3-car garage....1997 UBC	Plan No. 2528	1999
New	Approved Basic #99-110535 BP	Plan: 2834 Two Story SFR - 1997 UBC	1999
New	Approved Basic #99-110537 BP	Plan: 2576 Two Story SFR - 1997 UB	1999
New	2-story SFR w/attached 3-car garage....1997 UBC	Plan # 2834	1999
New	Approved Basic #99-110534 BP	Plan: 2528 Two Story SFR - 1997 UBC	1999
New	2-story SFR w/attached 3-car garage.....1997 UBC	Plan # 2576	1999
New	Approved Basic #99-112258 BP	Plan: 3405 Elev. A Two Story SFR - 19	1999
New	Approved Basic #98-110372BP	Two Story SFR - 1997 UBC	Plan: #257 1999
New	Approved Basic #98-109883BP	Two Story SFR - 1997 UBC	Plan: #244 1999
New	Two Story SFR - 1997 UBC		1999
New	Approved Basic #98-110372BP	Two Story SFR - 1997 UBC	Plan: #257 1999
New	Two Story SFR - 1997 UBC		1999
New	Two Story SFR with Finished Basement	ERROR ON ORIGINAL PERMIT, Floor square footage tra	1999
New	2784 sf 2-story w/130sf covered deck/porch and 32 sf open deck		1999
New	2 story SFR with attached garage		1999
New	Rambler With Attached Garage		1999
New	Rambler w/attached garage.....1997 UBC		1999
New	One-story SFR w/attached garage		1999
New	Two-story SFR w/attached garage		1999

Accessory Dwelling Units

Index # - File Name: 1.0022 - Single Family Dwellings Data\_Snohomish County.pdf

New	50 x 41	1999 Redman.		1999
New	1406 sf	2-story w/518 sf garage		1999
New	New	2149 sf SFR with attached three car garage.		1999
New	Rambler with Attached	Garage		1999
New	2-Story SFR w/attached	garage.		1999
New	1999	28 x 56 Skyline		1999
New	27 x 48	1999 Golden West		1999
New	Approved Basic #98-110280BP	Two Story SFR - 1997 UBC	Plan: #703	1999
New	Approved Basic #98-110276BP	Two Story SFR - 1997 UBC	Plan: #702	1999
New	Approved Basic #98-110280BP	Two Story SFR - 1997 UBC	Plan: #703	1999
New	Approved Basic #98-110276BP	Two Story SFR - 1997 UBC	Plan: #702	1999
New	Approved Basic #98-110276BP	Two Story SFR - 1997 UBC	Plan: #702	1999
New	Approved Basic #98-110272BP	Two Story SFR - 1997 UBC	Plan: #701	1999
New	Approved Basic #98-110280BP	Two Story SFR - 1997 UBC	Plan: #703	1999
New	Approved Basic #98-110280BP	Two Story SFR - 1997 UBC	Plan: #703	1999
New	Approved Basic #98-110280BP	Two Story SFR - 1997 UBC	Plan: #703	1999
New	Approved Basic #98-110276BP	Two Story SFR - 1997 UBC	Plan: #702	1999
New	Approved Basic #98-110276BP	Two Story SFR - 1997 UBC	Plan: #702	1999
New	Approved Basic #98-110280BP	Two Story SFR - 1997 UBC	Plan: #703	1999
New	Approved Basic #98-110280BP	Two Story SFR - 1997 UBC	Plan: #703	1999
New	Approved Basic #98-110280BP	Two Story SFR - 1997 UBC	Plan: #703	1999
New	Approved Basic #98-110276BP	Two Story SFR - 1997 UBC	Plan: #702	1999
New	Approved Basic #98-110276BP	Two Story SFR - 1997 UBC	Plan: #702	1999
New	Approved Basic #98-110272BP	Two Story SFR - 1997 UBC	Plan: #701	1999
New	Approved Basic #98-110280BP	Two Story SFR - 1997 UBC	Plan: #703	1999
New	Approved Basic #98-110276BP	Two Story SFR - 1997 UBC	Plan: #702	1999
New	Approved Basic #98-110273BP	Two Story SFR - 1997 UBC	Plan: #553	1999
New	Approved Basic #98-110273BP	Two Story SFR - 1997 UBC	Plan: #553	1999
New	Approved Basic #98-110273BP	Two Story SFR - 1997 UBC	Plan: #553	1999
New	Approved Basic #98-110278BP	Two Story SFR - 1997 UBC	Plan: #552	1999
New	Approved Basic #98-110273BP	Two Story SFR - 1997 UBC	Plan: #553	1999
New	Approved Basic #98-110273BP	Two Story SFR - 1997 UBC	Plan: #553	1999
New	Approved Basic #98-110273BP	Two Story SFR - 1997 UBC	Plan: #553	1999
New	Approved Basic #98-110278BP	Two Story SFR - 1997 UBC	Plan: #552	1999
New	Approved Basic #98-110273BP	Two Story SFR - 1997 UBC	Plan: #553	1999
New	Two Story SFR - 1997 UBC		Plan: #552	1999
New	Two Story SFR - 1997 UBC		Plan: #553	1999
New	Approved Basic #98-110278BP	Two Story SFR - 1997 UBC	Plan: #552	1999
New	Approved Basic #98-110280BP	Two Story SFR - 1997 UBC	Plan: #703	1999
New	Two Story SFR - 1997 UBC		Plan: #703	1999
New	Two Story SFR - 1997 UBC		Plan: #702	1999
New	2000	27 x 56 Marlette		1999
New	2006 sf	2-story w/748 sf gaarage and 30 sf covered porch and 120 sf open deck		1999
New	One-story SFR w/attached	garage		1999
New	Two story SFR with attached	three car garage.		1999
New	Two Story SFR - 1997 UBC		Plan: T 121A	1999

Accessory Dwelling Units

Index # - File Name: 1.0022 - Single Family Dwellings Data\_Snohomish County.pdf

New	2 story SFR w/ attached garage		1999
New	2 story SFR w/ attached garage		1999
New	2 story SFR w/ attached garage		1999
New	2-story SFR w/attached garage - 1997 UBC		1999
New	2-story w/attached garage - 1997 UBC		1999
New	Two Story SFR - 1997 UBC		1999
New	Two Story SFR - 1997 UBC	Plan: T 124B	1999
New	2 Story w/3 Car		1999
New	30 x 66 1999 Liberty		1999
New	Approved Basic #98-108806BP	Plan 1936 Split 1174 sf SFR w/762 sf ur	1999
New	Approved Basic #98-106871BP	Two Story SFR - 1997 UBC	1999
New	Approved Basic #98-106867BP	(4 Bedroom) Two Story SFR - 1997 UBC	1999
New	Approved Basic #98-106859BP	Plan #1607 Two Story SFR - 1997 U	1999
New	Approved Basic #98-106867BP	(4 Bedroom) Two Story SFR - 1997 UBC	1999
New	Approved Basic #98-106871BP	Two Story SFR - 1997 UBC	1999
New	Approved Basic #98-106862BP	(4 Bedroom w/opt. 5th bedroom) Two Story SFI	1999
New	Approved Basic #98-106865BP	(5 Bedroom) Two Story SFR - 1997 UBC	1999
New	Approved Basic #98-106859BP	Plan #1607 Two Story SFR - 1997 U	1999
New	Approved Basic #98-106869BP	Plan #2216 Two Story SFR - 19	1999
New	Approved Basic #98-106871BP	Two Story SFR - 1997 UBC	1999
New	Approved Basic #98-106867BP	(4 Bedroom) Two Story SFR - 1997 UBC	1999
New	Approved Basic #98-106871BP	Two Story SFR - 1997 UBC	1999
New	Approved Basic #98-106866BP	(3 Bedroom) Two Story SFR - 1997 UBC	1999
New	Approved Basic #98-106871BP	Two Story SFR - 1997 UBC	1999
New	Approved Basic #98-106867BP	(4 Bedroom) Two Story SFR - 1997 UBC	1999
New	Approved Basic #98-106859BP	Plan #1607 Two Story SFR - 1997 U	1999
New	Approved Basic #98-106862BP	(4 Bedroom w/opt. 5th bedroom) Two Story SFI	1999
New	Approved Basic #98-106871BP	Two Story SFR - 1997 UBC	1999
New	Approved Basic #98-106869BP	Plan #2216 Two Story SFR - 19	1999
New	Approved Basic #98-106866BP	(3 Bedroom) Two Story SFR - 1997 UBC	1999
New	Approved Basic #98-106859BP	Plan #1607 Two Story SFR - 1997 U	1999
New	Approved Basic #98-106865BP	(5 Bedroom) Two Story SFR - 1997 UBC	1999
New	Approved Basic #98-106871BP	Two Story SFR - 1997 UBC	1999
New	Approved Basic #98-106867BP	(4 Bedroom) Two Story SFR - 1997 UBC	1999
New	Approved Basic #98-106871BP	Two Story SFR - 1997 UBC	1999
New	Approved Basic #98-106867BP	(4 Bedroom) Two Story SFR - 1997 UBC	1999
New	Approved Basic #98-106866BP	(3 Bedroom) Two Story SFR - 1997 UBC	1999
New	Approved Basic #98-106869BP	Plan #2216 Two Story SFR - 19	1999
New	Approved Basic #98-106871BP	Two Story SFR - 1997 UBC	1999
New	Approved Basic #98-106867BP	(4 Bedroom) Two Story SFR - 1997 UBC	1999
New	Approved Basic #98-106866BP	(3 Bedroom) Two Story SFR - 1997 UBC	1999
New	Approved Basic #98-106871BP	Two Story SFR - 1997 UBC	1999
New	Approved Basic #98-106869BP	Plan #2216 Two Story SFR - 19	1999
New	Approved Basic #98-106862BP	(4 Bedroom w/opt. 5th bedroom) Two Story SFI	1999
New	Approved Basic #98-106859BP	Plan #1607 Two Story SFR - 1997 U	1999
New	Approved Basic #98-106867BP	(4 Bedroom) Two Story SFR - 1997 UBC	1999
New	Approved Basic #98-106871BP	Two Story SFR - 1997 UBC	1999

Accessory Dwelling Units

Index # - File Name: 1.0022 - Single Family Dwellings Data\_Snohomish County.pdf

New	Approved Basic #98-106862BP	(4 Bedroom w/opt. 5th bedroom)	Two Story SFI	1999
New	Approved Basic #98-106865BP	(5 Bedroom)	Two Story SFR - 1997 UBC	1999
New	Approved Basic #98-106871BP	Two Story SFR - 1997 UBC		1999
New	Approved Basic #98-106867BP	(4 Bedroom)	Two Story SFR - 1997 UBC	1999
New	Approved Basic #98-106859BP	Plan #1607	Two Story SFR - 1997 UBC	1999
New	Approved Basic #98-106867BP	(4 Bedroom)	Two Story SFR - 1997 UBC	1999
New	Approved Basic #98-106871BP	Two Story SFR - 1997 UBC		1999
New	Approved Basic #98-106869BP	Plan #2216	Two Story SFR - 1997 UBC	1999
New	Approved Basic #98-106865BP	(5 Bedroom)	Two Story SFR - 1997 UBC	1999
New	Approved Basic #98-106862BP	(4 Bedroom w/opt. 5th bedroom)	Two Story SFI	1999
New	Approved Basic #98-106859BP	Plan #1607	Two Story SFR - 1997 UBC	1999
New	Approved Basic #98-106871BP	Two Story SFR - 1997 UBC		1999
New	Approved Basic #98-106859BP	Plan #1607	Two Story SFR - 1997 UBC	1999
New	Approved Basic #98-106867BP	(4 Bedroom)	Two Story SFR - 1997 UBC	1999
New	Approved Basic #98-106871BP	Two Story SFR - 1997 UBC		1999
New	Approved Basic #98-106866BP	(3 Bedroom)	Two Story SFR - 1997 UBC	1999
New	2 story SFR w/ 2 car garage			1999
New	Two Story SFR - 1997 UBC	Plan: 9514		1999
New	Two Story SFR - 1997 UBC	PLan #1938 B		1999
New	Approved Basic #98-110723BP	Two Story SFR - 1997 UBC	Plan	1999
New	Approved Basic #99-101698BP	Plan #9514	Two Story SFR - 1997 UBC	1999
New	Two Story SFR - 1997 UBC	Plan: 2206		1999
New	2-story w/ 3-car garage			1999
New	Approved Basic #98-150653BP	Plan: #1938 B	Two Story SFR - 1997 UBC	1999
New	Approved Basic #99-101703BP	Plan #2206	Two Story SFR - 1997 UBC	1999
New	Approved Basic #99-101313BP	Bldrs. Plan #2018	2-Story SFR v	1999
New	Approved Basic #99-101313BP	Bldrs. Plan #2018	2-Story SFR v	1999
New	Approved Basic #98-110724BP	Two Story SFR - 1997 UBC	Plan	1999
New	SFR with attached 2 story Garage			1999
New	Approved Basic #99-103276BP	Plan: #2461	Two Story SFR - 1997 UBC	1999
New	New two story with three car SFR.			1999
New	2-story SFR			1999
New	Two Story SFR - 1997 UBC			1999
New	2-Story SFR w/attached garage.	1997-UBC		1999
New	STOP WORK ORDER POSTED 10/19/99 - GS - EROSION CONTROL & GRADING W/OUT PERMIT	2		1999
New	2 Story w/3 Car	Plan #2704		1999
New	Two-story SFR w/attached garage			1999
New	2 story sfr with 3 car garage			1999
New	Approved Basic #98-116126BP	Plan 2704	Two Story SFR - 1997 UBC	1999
New	Approved Basic #98-116126BP	Plan 2704	Two Story SFR - 1997 UBC	1999
New	Approved Basic #98-150658BP	Plan 2210	Two-story SFR w/attach	1999
New	2-story SFR with attached garage			1999
New	Approved Basic #98-116126BP	Plan 2704	Two Story SFR - 1997 UBC	1999
New	Approved Basic 99-100896BP	2 story w/ three car. Builders	Plan # 3036.	1999
New	Approved Basic #99-013276BP	Plan: #2461	2-story SFR w/attached	1999
New	Approved Basic #98-116126BP	Plan 2704	Two Story SFR - 1997 UBC	1999
New	Approved Basic #99-103276BP	Plan: #2461	Two Story SFR - 1997 UBC	1999

Accessory Dwelling Units

Index # - File Name: 1.0022 - Single Family Dwellings Data\_Snohomish County.pdf

New	Approved Basic 99-100896 BP	2 story w/ three car. BuildersPlan # 3036.		1999
New	Approved Basic #98-150658BP		Plan 2210 Two-story SFR w/attach	1999
New	Approved Basic 99-103316BP		Plan: #5045 B Two Story SFR - 1997 UBC	1999
New	Approved Basic #98-150658BP		Plan 2210 Two-story SFR w/attach	1999
New		two story SFR with attached three car garage.		1999
New		Split Entry Style SFR w/Basement garage & Finished Basement - 1997 UBC		1999
New		27 x 56 + 14 x 30 Pod - 1999 Skyline Amber Cove		1999
New		27 x 66 Skyline Ambercove		1999
New		Split Level SFR with semi finished basement and attached garage		1999
New	Approved Basic #98-110273BP	Two Story SFR - 1997 UBC	Plan: #553	1999
New	Approved Basic #98-110275BP	Two Story SFR - 1997 UBC	Plan: #551	1999
New	Approved Basic #98-110278BP	Two Story SFR - 1997 UBC	Plan: #552	1999
New	Approved Basic #98-110273BP	Two Story SFR - 1997 UBC	Plan: #553	1999
New	Approved Basic #98-110273BP	Two Story SFR - 1997 UBC	Plan: #553	1999
New	Approved Basic #98-110273BP	Two Story SFR - 1997 UBC	Plan: #553	1999
New	Approved Basic #98-110278BP	Two Story SFR - 1997 UBC	Plan: #552	1999
New	Approved Basic #98-110273BP	Two Story SFR - 1997 UBC	Plan: #553	1999
New	Approved Basic #98-110273BP	Two Story SFR - 1997 UBC	Plan: #553	1999
New	Approved Basic #98-110278BP	Two Story SFR - 1997 UBC	Plan: #552	1999
New	Approved Basic #98-110273BP	Two Story SFR - 1997 UBC	Plan: #553	1999
New	Approved Basic #98-110273BP	Two Story SFR - 1997 UBC	Plan: #553	1999
New	Approved Basic #98-110278BP	Two Story SFR - 1997 UBC	Plan: #552	1999
New	Approved Basic #98-110273BP	Two Story SFR - 1997 UBC	Plan: #553	1999
New	Approved Basic #98-110273BP	Two Story SFR - 1997 UBC	Plan: #553	1999
New	Approved Basic #98-110275BP	Two Story SFR - 1997 UBC	Plan: #551	1999
New	Approved Basic #98-110273BP	Two Story SFR - 1997 UBC	Plan: #553	1999
New	Approved Basic #98-110278BP	Two Story SFR - 1997 UBC	Plan: #552	1999
New	Approved Basic #98-110273BP	Two Story SFR - 1997 UBC	Plan: #553	1999
New	Approved Basic #98-110273BP	Two Story SFR - 1997 UBC	Plan: #553	1999
New	Approved Basic #98-110273BP	Two Story SFR - 1997 UBC	Plan: #553	1999
New	Approved Basic #98-110278BP	Two Story SFR - 1997 UBC	Plan: #552	1999
New	Approved Basic #98-110273BP	Two Story SFR - 1997 UBC	Plan: #553	1999
New	Approved Basic #98-110273BP	Two Story SFR - 1997 UBC	Plan: #553	1999
New	Approved Basic #98-110278BP	Two Story SFR - 1997 UBC	Plan: #552	1999
New	Approved Basic #98-110273BP	Two Story SFR - 1997 UBC	Plan: #553	1999
New	Approved Basic #98-110273BP	Two Story SFR - 1997 UBC	Plan: #553	1999
New	Approved Basic #98-110278BP	Two Story SFR - 1997 UBC	Plan: #552	1999
New	Approved Basic #98-110273BP	Two Story SFR - 1997 UBC	Plan: #553	1999
New	Approved Basic #98-110273BP	Two Story SFR - 1997 UBC	Plan: #553	1999
New	Approved Basic #98-110276BP	Two Story SFR - 1997 UBC	Plan: #702	1999
New	Approved Basic #98-110276BP	Two Story SFR - 1997 UBC	Plan: #702	1999
New	Approved Basic #98-110280BP	Two Story SFR - 1997 UBC	Plan: #703	1999
New	Approved Basic #98-110280BP	Two Story SFR - 1997 UBC	Plan: #703	1999
New	Approved Basic #98-110280BP	Two Story SFR - 1997 UBC	Plan: #703	1999
New	Approved Basic #98-110276BP	Two Story SFR - 1997 UBC	Plan: #702	1999
New	Approved Basic #98-110276BP	Two Story SFR - 1997 UBC	Plan: #702	1999
New	Approved Basic #98-110280BP	Two Story SFR - 1997 UBC	Plan: #703	1999
New	Approved Basic #98-110280BP	Two Story SFR - 1997 UBC	Plan: #703	1999
New	Approved Basic #98-110276BP	Two Story SFR - 1997 UBC	Plan: #702	1999
New	Approved Basic #98-110280BP	Two Story SFR - 1997 UBC	Plan: #703	1999
New	Approved Basic #98-110276BP	Two Story SFR - 1997 UBC	Plan: #702	1999
New	Approved Basic #98-110280BP	Two Story SFR - 1997 UBC	Plan: #703	1999
New	Approved Basic #98-110276BP	Two Story SFR - 1997 UBC	Plan: #702	1999
New	Approved Basic #98-110280BP	Two Story SFR - 1997 UBC	Plan: #703	1999





Accessory Dwelling Units

Index # - File Name: 1.0022 - Single Family Dwellings Data\_Snohomish County.pdf

New	Approved Basic #98-110280BP	Two Story SFR - 1997 UBC	Plan: #703	1999
New	Approved Basic #98-110276BP	Two Story SFR - 1997 UBC	Plan: #702	1999
New	Approved Basic #98-110272BP	Two Story SFR - 1997 UBC	Plan: #701	1999
New	Approved Basic #98-110280BP	Two Story SFR - 1997 UBC	Plan: #703	1999
New	Approved Basic #98-110280BP	Two Story SFR - 1997 UBC	Plan: #703	1999
New	Approved Basic #98-110280BP	Two Story SFR - 1997 UBC	Plan: #703	1999
New	Approved Basic #98-110276BP	Two Story SFR - 1997 UBC	Plan: #702	1999
New	Approved Basic #98-110278BP	Two Story SFR - 1997 UBC	Plan: #552	1999
New	Approved Basic #98-110273BP	Two Story SFR - 1997 UBC	Plan: #553	1999
New	Approved Basic #98-110278BP	Two Story SFR - 1997 UBC	Plan: #552	1999
New	Approved Basic #98-110273BP	Two Story SFR - 1997 UBC	Plan: #553	1999
New	Approved Basic #98-110273BP	Two Story SFR - 1997 UBC	Plan: #553	1999
New	Approved Basic #98-110278BP	Two Story SFR - 1997 UBC	Plan: #552	1999
New	Approved Basic #98-110276BP	Two Story SFR - 1997 UBC	Plan: #702	1999
New	Approved Basic #98-110280BP	Two Story SFR - 1997 UBC	Plan: #703	1999
New	Approved Basic #98-110280BP	Two Story SFR - 1997 UBC	Plan: #703	1999
New	Approved Basic #98-110280BP	Two Story SFR - 1997 UBC	Plan: #703	1999
New	Approved Basic #98-110276BP	Two Story SFR - 1997 UBC	Plan: #702	1999
New	Two Story SFR - 1997 UBC	Plan: #701		1999
New	Approved Basic #98-110280BP	Two Story SFR - 1997 UBC	Plan: #703	1999
New	Approved Basic #98-110280BP	Two Story SFR - 1997 UBC	Plan: #703	1999
New	Approved Basic #98-110276BP	Two Story SFR - 1997 UBC	Plan: #702	1999
New	Approved Basic #98-110276BP	Two Story SFR - 1997 UBC	Plan: #702	1999
New	Approved Basic #98-110276BP	Two Story SFR - 1997 UBC	Plan: #702	1999
New	Approved Basic #98-110276BP	Two Story SFR - 1997 UBC	Plan: #702	1999
New	Approved Basic #98-110280BP	Two Story SFR - 1997 UBC	Plan: #703	1999
New	Approved Basic #98-110272BP	Two Story SFR - 1997 UBC	Plan: #701	1999
New	Approved Basic #98-110280BP	Two Story SFR - 1997 UBC	Plan: #703	1999
New	Approved Basic #98-110276BP	Two Story SFR - 1997 UBC	Plan: #702	1999
New	Approved Basic #98-110280BP	Two Story SFR - 1997 UBC	Plan: #703	1999
New	Approved Basic #98-110280BP	Two Story SFR - 1997 UBC	Plan: #703	1999
New	Approved Basic #98-110276BP	Two Story SFR - 1997 UBC	Plan: #702	1999
New	Approved Basic #98-109999BP	Two Story SFR - 1997 UBC	Plan: #450	1999
New	Approved Basic #98-110000BP	Two Story SFR - 1997 UBC	Plan: #450	1999
New	Approved Basic #99 103025 BP	Plan: 1450 S SFR w/finished baser		1999
New	Approved Basic #99 103025 BP	Plan: 1450 S SFR w/finished baser		1999
New	2 story SFR with unfinished daylight basement and covered porch			1999
New	2 story SFR with attached garage and covered porch			1999
New	New 3756sf SFR with attached three car garage & carport			1999
New	Approved Basic #99-103832BP	Plan: 4003 Two Story SFR - 199		1999
New	2 story sfr with 3 car garage			1999
New	2 story sfr w/unfinished basement & 3 car garage			1999
New	Approved Basic #99-103724BP	Plan: Chelsea III-A Two Story SFR - 19		1999
New	Approved Basic #99-101683BP	SFR w/finshed basement - 1997 UBC		1999
New	1999 27 x 52 Fleetwood Greenhill			1999
New	2 Story SFR w/ attached 3 car garage			1999
New	New 3650 sf two story SFR with attached three car garage			1999
New	Approved Basic #99-103057BP	Two Story SFR - 1997 UBC	PI	1999

Accessory Dwelling Units

Index # - File Name: 1.0022 - Single Family Dwellings Data\_Snohomish County.pdf

New	Approved Basic #99-103052BP	Two Story SFR - 1997 UBC	Plan #	1999
New	Approved Basic #99-103052BP	Two Story SFR - 1997 UBC	Plan #	1999
New	Approved Basic #99-103057BP	Two Story SFR - 1997 UBC	PI	1999
New	Approved Basic #99-103056BP	Two Story SFR - 1997 UBC	Plan #	1999
New	Approved Basic #99-103051BP	Two Story SFR - 1997 UBC	Plan #:	1999
New	Approved Basic #99-103057BP	Two Story SFR - 1997 UBC	PI	1999
New	Approved Basic #99-103051BP	Two Story SFR - 1997 UBC	Plan #:	1999
New	Approved Basic #99-103057BP	Two Story SFR - 1997 UBC	PI	1999
New	Approved Basic #99-103057BP	Two Story SFR - 1997 UBC	PI	1999
New	Approved Basic #99-103051BP	Two Story SFR - 1997 UBC	Plan #:	1999
New	Approved Basic #99-103056BP	Two Story SFR - 1997 UBC	Plan #	1999
New	Approved Basic #99-103056BP	Two Story SFR - 1997 UBC	Plan #	1999
New	Approved Basic #99-103051BP	Two Story SFR - 1997 UBC	Plan #:	1999
New	Approved Basic #99-103051BP	Two Story SFR - 1997 UBC	Plan #:	1999
New	Approved Basic #99-103057BP	Two Story SFR - 1997 UBC	PI	1999
New	Two Story SFR w/attached garage.			1999
New	Two Story SFR - 1997 UBC			1999
New	Two Story SFR - 1997 UBC	Plan: #2272		1999
New	Approved Basic #98-150959BP	Two Story SFR w/unfinished basement - 1997 UBC		1999
New	Approved Basic #98-150959BP	Two Story SFR w/unfinished basement - 1997 UBC		1999
New	2-Story SFR w/unfin. daylight-basement - 1997 UBC			1999
New	Approved Basic #99-103777BP		Plan: 2415 A/3 Two Story SFR - 1997	1999
New	Approved Basic #98-107885BP		Plan: #1908/side Two Story SFR - 1997	1999
New	Approved Basic #98-150960BP	Two Story SFR - 1997 UBC	Plan: 2329	1999
New	Rambler Style SFR - 1997 UBC			1999
New	Two Story SFR - 1997 UBC	7/26/99 - Builder submitted for extra set of plans		1999
New	Approved Basic #98-108798BP		Plan 2161 Two Story SFR - 1997 UBC	1999
New	Two Story SFR - 1997 UBC		Plan: 2422	1999
New	Approved Basic #98-150960BP	Two Story SFR - 1997 UBC	Plan: 2329	1999
New	Two Story SFR - 1997 UBC		Plan: #2272	1999
New	Approved Basic #98-150961BP	Two Story SFR - 1997 UBC	Plan: 2203	1999
New	Approved Basic #98-108798BP		Plan 2161 Two Story SFR - 1997 UBC	1999
New	Approved Basic #98-108798BP		Plan 2161 Two Story SFR - 1997 UBC	1999
New	Approved Basic #98-107885BP		Plan: #1908/side Two Story SFR - 1997	1999
New	Approved Basic #98-150960BP	Two Story SFR - 1997 UBC	Plan: 2329	1999
New	Approved Basic #98-150960BP	Two Story SFR - 1997 UBC	Plan: 2329	1999
New	Approved Basic #98-150960BP	Two Story SFR - 1997 UBC	Plan: 2329	1999
New	Two Story SFR - 1997 UBC		Plan: 2001	1999
New	Approved Basic #99-103777BP		Plan: 2415 A/3 Two Story SFR - 1997	1999
New	Approved Basic #98-150960BP	Two Story SFR - 1997 UBC	Plan: 2329	1999
New	Approved Basic #98-108798BP		Plan 2161 Two Story SFR - 1997 UBC	1999
New	Approved Basic #98-108798BP		Plan 2161 Two Story SFR - 1997 UBC	1999
New	Approved Basic #98-116645BP		Plan: 1915 Two Story SFR - 1997 UBC	1999
New	Two Story SFR - 1997 UBC		Plan: 2070	1999
New	Two Story SFR - 1997 UBC		Plan: #2445	1999
New	Approved Basic #99-109776 BP		Plan: 2397 w/bonus Two Story SFR -	1999
New	Split level with finished basement and 2 car garage			1999

Accessory Dwelling Units

Index # - File Name: 1.0022 - Single Family Dwellings Data\_Snohomish County.pdf

New	2 Story w/semi-fin bstm & 2 car		1999
New	Two Story SFR - 1997 UBC	Plan: 2115	1999
New	Two Story SFR - 1997 UBC	Plan: 1905	1999
New	Two Story SFR - 1997 UBC	Plan: 1870	1999
New	Approved Basic 99105003 BP	Builders Plan 9410-A Two-story SFR \	1999
New	Mid-entry SFR w/attached 2-car garage.....1997 UBC		1999
New	2-story SFR w/attached 3-car garage....1997 UBC		1999
New	3368 sq ft Rambler.....1997 UBC	Stop work posted 4/30/99. DN Grdg w/o permit. #3106	1999
New	28x46 (1997) Fleetwood		1999
New	Split-level SFR - 1997 UBC		1999
New	Split-level SFR - 1997 UBC		1999
New	2-story SFR w/attached 2-car garage....1997 UBC		1999
New	Split Level SFR with attached garage and covered porch		1999
New	Two Story SFR - 1997 UBC	Plan #2707	1999
New	2-Story SFR w/attached Garage & Covered Porch - 1997 UBC		1999
New	Approved Basic #98-116125BP	Plan #2707 Two Story SFR - 1997 U	1999
New	Approved Basic #98-116414BP	Plan: 2483 Two Story SFR - 1997 UBC	1999
New	Approved Basic #98-116125BP	Plan #2707 Two Story SFR - 1997 U	1999
New	Approved Basic #98-150654BP	Plan 2172 Two-story SFR w/attache	1999
New	Approved Basic #98-116414BP	Plan: 2483 Two Story SFR - 1997 UBC	1999
New	Approved Basic #98-116125BP	Plan #2707 Two Story SFR - 1997 U	1999
New	Approved Basic #98-116414BP	Plan: 2483 Two Story SFR - 1997 UBC	1999
New	Approved Basic #98-116125BP	Plan #2707 Two Story SFR - 1997 U	1999
New	Rambler style SFR w/attached garage.		1999
New	2770 2-story w/800 sf garage, w/ 800 sf covered deck/porch, and 888 sf open deck		1999
New	1999 Silvercrest 66 x 40		1999
New	Daylight Basement Rambler w/attached garage & unfinished basement. - 1997 UBC		1999
New	Approved Basic #98-110058BP	Split Entry Style SFR w/basement gara	1999
New	1213 sf rambler w/598 sf unfinished basement, 532 sf garage and 124 sf open deck		1999
New	2 story SFR with attached garage		1999
New	Rambler with attached garage and unfinished basement- 1997 UBC		1999
New	2 Story SFR with attached garage - 1997 UBC		1999
New	2 story SFR		1999
New	27.5 x 66 1998 Golden West		1999
New	Approved Basic #98-107691BP	(4 Bedrooms) Option Approved: 3rd car bay Two S	1999
New	Approved Basic #99-101219BP	Two Story SFR - 1997 UBC	Plan: 71 1999
New	Approved Basic #99-100953BP	Two Story SFR - 1997 UBC	Plan: 71 1999
New	Approved Basic #99-10121BP	Two Story SFR - 1997 UBC	Plan: 7 1999
New	Approved Basic #99-109705 BP	Plan: 7006 C Two Story SFR - 1997 UE	1999
New	Approved Basic #98-107691BP	Option Approved: 3rd car bay Two Story SFR - 1997 U	1999
New	Approved Basic #99-101212BP	Two Story SFR - 1997 UBC	Plan: 1999
New	Approved Basic #99-101212BP	Two Story SFR - 1997 UBC	Plan: 1999
New	Approved Basic #99-103349BP	Plan: 5318 Two Story SFR - 199	1999
New	Approved Basic #99-109704 BP	Plan: 7006 A Two Story SFR - 1997 UE	1999
New	Two Story SFR - 1997 UBC	Plan: 7018	1999
New	Two Story SFR - 1997 UBC	Plan: 7017	1999
New	Two Story SFR - 1997 UBC	Plan: 7016	1999

Accessory Dwelling Units

Index # - File Name: 1.0022 - Single Family Dwellings Data\_Snohomish County.pdf

New	Two Story SFR - 1997 UBC	Plan: 7015 A/B	1999
New	Approved Basic #99-109704 BP	Plan: 7006 A Two Story SFR - 1997 UBC	1999
New	Approved Basic #99-100953BP Two Story SFR - 1997 UBC	Plan: 7006 A	1999
New	Approved Basic #99-10121BP Two Story SFR - 1997 UBC	Plan: 7006 A	1999
New	Two Story SFR - 1997 UBC	Plan: 5722	1999
New	Approved Basic #99-109704 BP	Plan: 7006 A Two Story SFR - 1997 UBC	1999
New	Two Story SFR - 1997 UBC	Plan: 5622	1999
New	Approved Basic #99-109705 BP	Plan: 7006 C Two Story SFR - 1997 UBC	1999
New	Approved Basic #99-100950BP Two Story SFR - 1997 UBC	Plan: 7006 C	1999
New	Two Story SFR - 1997 UBC	Plan: 5522	1999
New	Approved Basic #99-100953BP Two Story SFR - 1997 UBC	Plan: 7006 C	1999
New	New 56 x 28 1999 Symphony		1999
New	1988 28 x 60 Fleetwood		1999
New	2 story sfr w/3 car garage		1999
New	New two story 4160 SFR with three car garage & unfinished basement.		1999
New	2-story SFR w/unfinished basement & 3-car garage....1997 UBC		1999
New	2 story sfr with unfinished basement & 2 car garage		1999
New	Approved Basic #99-102550BP	Plan: 2064 Rambler Style SFR - 1997	1999
New	2 Story w/2 Car		1999
New	2-story SFR w/attached 2-car garage.....1997 UBC		1999
New	Two-story SFR w/attached Garage - 1997 UBC	Plan 3414	1999
New	Two Story SFR with Attached Garage		1999
New	1999 40 x 66ft Triple wide MH		1999
New	2 story sfr w/3 car garage		1999
New	Rambler w/attached 3-car garage....1997 UBC		1999
New	Approved Basic #98-109883BP Two Story SFR - 1997 UBC	Plan: #244	1999
New	Rambler w/attached 2-car garage.....1997 UBC		1999
New	2 Story w/3 Car		1999
New	One-story SFR w/attached garage		1999
New	One-story SFR w/attached garage		1999
New	Rambler style SFR with attached garage		1999
New	Rambler Style SFR - 1997 UBC	Plan: 1803/3 car	1999
New	14x56 1999 Liberty Mobile Home		1999
New	3078sf, two story Duplex with attached, 4 car garage.		1999
New	2-Story SFR w/attached garage.		1999
New	One-story SFR w/attached garage	Builders Plan 1803-3C	1999
New	Two-story SFR w/attached garage	Builders Plan 2106-3C	1999
New	Rambler w/attached 3-car garage.....1997 UBC		1999
New	Rambler style SFR with attached garage and covered porch		1999
New	2-story SFR w/attached 3-car garage.....1997 UBC		1999
New	Rambler Style SFR - 1997 UBC	Plan: 1803/2 car	1999
New	Rambler Style SFR - 1997 UBC	Plan: 1803/2 car	1999
New	Two Story SFR - 1997 UBC	Plan: 2106	1999
New	2-Story SFR w/attached garage		1999
New	Rambler style SFR w/attached garage		1999
New	One-story SFR w/attached garage		1999
New	2480 sf rambler w/2480 sf unfinished basement, 1173 sf garaage, and 100 sf covered deck/porc		1999

Accessory Dwelling Units

Index # - File Name: 1.0022 - Single Family Dwellings Data\_Snohomish County.pdf

New	2-story SFR w/unfinished basement.....1997 UBC		1999
New	41 x 48 1999 Redman		1999
New	40 x 66 1999 Fleetwood		1999
New	52 x 27 - 1998 Golden West		1999
New	Approved Basic #99-105443BP	Plan: 2339 Two Story SFR - 1997 UE	1999
New	2-story SFR w/attached 3-car garage....1997 UBC		1999
New	One-story SFR w/attached garage		1999
New	Two Story SFR w/unfinished basement - 1997 UBC		1999
New	Two Story SFR - 1997 UBC		1999
New	2 story sfr w/3 car garage		1999
New	Rambler Style SFR - 1997 UBC	Plan: 1502	1999
New	Rambler style SFR with attached garage		1999
New	Rambler Style SFR - 1997 UBC		1999
New	Two Story SFR - 1997 UBC	Plan: 1932	1999
New	Rambler w/attached 3-car garage....1997 UBC		1999
New	Two Story SFR - 1997 UBC	Plan: 1932	1999
New	Approved Basic #99-111975 BP	Plan: 1533 Two Story SFR - 199	1999
New	Rambler style SFR with attached garage		1999
New	Approved Basic #99-111975 BP	Plan: 1533 Two Story SFR - 199	1999
New	Rambler style SFR with attached garage		1999
New	Two Story SFR - 1997 UBC	Plan: 2171	1999
New	2 story SFR with attached garage		1999
New	2 story sfr with 2 car garage		1999
New	Rambler Style SFR - 1997 UBC	Plan: #1739	1999
New	3000 sf 2-story w/560 sf unfinished basement, 1305 sf garage, and 618 sf covered deck/porch		1999
New	Two Story SFR w/finished lower area - 1997 UBC	Plan: 2475	1999
New	Two Story SFR - 1997 UBC	Plan: 2415	1999
New	Approved Basic #99-102550BP	Plan: 2064 Rambler Style SFR - 1997 UBC	1999
New	Approved Basic #99-103817BP	Plan: 1200 (Floor Framing Change) Rambler	1999
New	Two-story SFR w/partially finished basement & attached garage		1999
New	Approved Basic #99-103817BP	Plan: 1200 (Floor Framing Change) Rambler	1999
New	Rambler Style SFR w/attached garage - 1997 UBC	Plan: 1200	1999
New	Rambler Style SFR - 1997 UBC	0 LOT LINE STRUCTURE	1999
New	Approved Basic #99-101472BP	Plan: 1200 Rambler Style - 1997 UBC	1999
New	Rambler Style SFR - 1997 UBC	Plan: 1195	1999
New	Approved Basic #99-101472BP	Plan: 1200 Rambler Style - 1997 UBC	1999
New	Approved Basic #99-101472BP	Plan: 1200 Rambler Style - 1997 UBC	1999
New	Approved Basic #99-101472BP	Plan: 1200 Rambler Style - 1997 UBC	1999
New	Approved Basic #99-101470BP	Plan: 1195 Rambler w/attached garage	1999
New	Approved Basic #99-101472BP	Plan: 1200 Rambler Style SFR - 1997 UBC	1999
New	Approved Basic #99-101472BP	Plan: 1200 Rambler Style SFR - 1997 UBC	1999
New	Approved Basic #99-101470BP	Plan: 1195 Rambler Style SFR - 1997 UBC	1999
New	Approved Basic #99-103817BP	Plan: 1200 (floor framing change) Rambler Style	1999
New	Approved Basic #99-103818BP	Plan: 1195 (floor framing change) Rambler Style	1999
New	Approved Basic #99-103817BP	Plan: 1200 (floor framing change) Rambler Style	1999
New	Approved Basic #99-103817BP	Plan: 1200 (Floor Framing Change) Rambler	1999
New	Approved Basic #99-103818BP	Plan: 1195 (Floor Framing Change) Rambler	1999

Accessory Dwelling Units

Index # - File Name: 1.0022 - Single Family Dwellings Data\_Snohomish County.pdf

New	Approved Basic #99-103817BP	Plan: 1200 (Floor Framing Change)	Rambler	1999
New	Approved Basic #99-103817BP	Plan: 1200 (Floor Framing Change)	Rambler	1999
New	Approved Basic #99-103817BP	Plan: 1200 (Floor Framing Change)	Rambler	1999
New	Approved Basic #99-103818BP	Plan: 1195 (Floor Framing Change)	Rambler	1999
New	Approved Basic #99-103817BP	Plan: 1200 (Floor Framing Change)	Rambler	1999
New	Approved Basic #99-103817BP	Plan: 1200 (Floor Framing Change)	Rambler	1999
New	Approved Basic #99-103817BP	Plan: 1200 (Floor Framing Change)	Rambler	1999
New	Approved Basic #99-103818BP	Plan: 1195 (Floor Framing Change)	Rambler	1999
New	Approved Basic #99-103817BP	Plan: 1200 (Floor Framing Change)	Rambler	1999
New	Approved Basic #99-103818BP	Plan: 1195 (Floor Framing Change)	Rambler	1999
New	Approved Basic #99-103817BP	Plan: 1200 (Floor Framing Change)	Rambler	1999
New	Approved Basic #99-103818BP	Plan: 1195 (Floor Framing Change)	Rambler	1999
New	Approved Basic #99-103817BP	Plan: 1200 (Floor Framing Change)	Rambler	1999
New	Approved Basic #99-103817BP	Plan: 1200 (Floor Framing Change)	Rambler	1999
New	Approved Basic #99-103818BP	Plan: 1195 (Floor Framing Change)	Rambler	1999
New	Approved Basic #99-103817BP	Plan: 1200 (Floor Framing Change)	Rambler	1999
New	Approved Basic #99-103818BP	Plan: 1195 (Floor Framing Change)	Rambler	1999
New	Approved Basic #99-103817BP	Plan: 1200 (Floor Framing Change)	Rambler	1999
New	Approved Basic #99-103817BP	Plan: 1200 (Floor Framing Change)	Rambler	1999
New	Approved Basic #99-103818BP	Plan: 1195 (Floor Framing Change)	Rambler	1999
New	Approved Basic #99-103817BP	Plan: 1200 (Floor Framing Change)	Rambler	1999
New	Approved Basic #99-103818BP	Plan: 1195 (Floor Framing Change)	Rambler	1999
New	Approved Basic #99-103817BP	Plan: 1200 (Floor Framing Change)	Rambler	1999
New	Approved Basic #99-103817BP	Plan: 1200 (Floor Framing Change)	Rambler	1999
New	Approved Basic #99-103818BP	Plan: 1195 (Floor Framing Change)	Rambler	1999
New	Approved Basic #99-103817BP	Plan: 1200 (Floor Framing Change)	Rambler	1999
New	Approved Basic #99-103818BP	Plan: 1195 (Floor Framing Change)	Rambler	1999
New	Approved Basic #99-103817BP	Plan: 1200 (Floor Framing Change)	Rambler	1999
New	Approved Basic #99-103817BP	Plan: 1200 (Floor Framing Change)	Rambler	1999
New	Approved Basic #99-103818BP	Plan: 1195 (Floor Framing Change)	Rambler	1999
New	Approved Basic #99-103817BP	Plan: 1200 (Floor Framing Change)	Rambler	1999
New	Approved Basic #99-103818BP	Plan: 1195 (Floor Framing Change)	Rambler	1999
New	Approved Basic #99-103817BP	Plan: 1200 (Floor Framing Change)	Rambler	1999
New	Approved Basic #99-103817BP	Plan: 1200 (Floor Framing Change)	Rambler	1999
New	Approved Basic #99-103818BP	Plan: 1195 (Floor Framing Change)	Rambler	1999
New	Approved Basic #99-101472BP	Plan: 1200	Rambler Style - 1997 UBC	1999
New	Approved Basic #99-103817BP	Plan: 1200 (Floor Framing Change)	Rambler	1999
New	Approved Basic #99-103818BP	Plan: 1195 (Floor Framing Change)	Rambler	1999
New	Approved Basic #99-110386 BP	Plan: Hawthorne	Rambler style SFF	1999
New	Approved Basic #99-109533 BP	Rambler w/attached 2-car garage....1997 UBC	Plan No	1999

Accessory Dwelling Units

Index # - File Name: 1.0022 - Single Family Dwellings Data\_Snohomish County.pdf

New	Approved Basic #98-110563BP	Plan 2146	Two Story SFR - 1997 UBC	1999
New	Rambler style SFR with attached garage			1999
New	Approved Basic #99-109533 BP	Rambler w/attached 2-car garage....1997 UBC	Plan No	1999
New	Approved Basic #98-110563BP	Plan 2146	Two Story SFR - 1997 UBC	1999
New	Approved Basic #99-109533 BP	Plan No. 1475	Rambler SFR - 1997 UBC	1999
New	Approved Basic #99-109533 BP	Rambler w/attached 2-car garage....1997 UBC	Plan No	1999
New	Approved Basic #99-109533 BP	Rambler w/attached 2-car garage....1997 UBC	Plan No	1999
New	Approved Basic #99-109533 BP	Rambler w/attached 2-car garage....1997 UBC	Plan No	1999
New	Approved Basic #99-109533 BP	Rambler w/attached 2-car garage....1997 UBC	Plan No	1999
New	Approved Basic #99-110535 BP	Plan: 2834	Two Story SFR - 1997 UBC	1999
New	2-story SFR w/attached 3-car garage....1997 UBC			1999
New	Two Story SFR - 1997 UBC	Plan: RH II-21		1999
New	Two Story SFR - 1997 UBC	Plan: 4001		1999
New	Two Story SFR - 1997 UBC	Plan: 5218/5318		1999
New	Two Story SFR - 1997 UBC	Plan: RH II-16		1999
New	Two Story SFR - 1997 UBC			1999
New	Two Story SFR - 1997 UBC	Plan: RH 2-14		1999
New	Approved Basic #99-103205BP	Two Story SFR - 1997 UBC	Plan RH II-5	1999
New	Two Story SFR - 1997 UBC	Plan RH II-9		1999
New	Two Story SFR - 1997 UBC	Plan RH II-6		1999
New	Two Story SFR - 1997 UBC	Plan RH II-1		1999
New	Approved Basic #99-105233BP	Two Story SFR - 1997 UBC	Plan: RH II-17	1999
New	Approved Basic #99-112600 BP	Two Story SFR - 1997 UBC	Plan: RH 14	1999
New	Approved Basic #99-103575BP	Two Story SFR - 1997 UBC	Plan: RH II-15	1999
New	Two Story SFR - 1997 UBC			1999
New	Approved Basic #99-103451BP	Two Story SFR - 1997 UBC	Plan RH II-5	1999
New	Two Story SFR - 1997 UBC	Plan RH II-5		1999
New	Approved Basic #99-103447BP	Two Story SFR - 1997 UBC	Plan: RH II-16	1999
New	Approved Basic #99-105044BP	Two Story SFR - 1997 UBC	Plan: RH II-14	1999
New	Approved Basic #99-103208 BP	Two Story SFR - 1997 UBC	Plan RH II-	1999
New	Approved Basic #99-112598 BP	Two Story SFR - 1997 UBC	Plan: RH II-	1999
New	*****Deviation from basic plan per C. Griffith, 7/21/99; need new plans and plan ck. before fu			1999
New	Approved Basic #99-103448BP	Two Story SFR - 1997 UBC	Plan RH II-6	1999
New	Two Story SFR - 1997 UBC	Plan: RH II-17		1999
New	Two Story SFR - 1997 UBC	Plan RH II-7		1999
New	Two Story SFR - 1997 UBC	Plan: RH II-2. ***STOP WORK POSTED 11/22/99 BY C. GRIFFITH - FE		1999
New	Two Story SFR - 1997 UBC	Plan RH II-8		1999
New	Two Story SFR - 1997 UBC	Plan RH II-10		1999
New	Approved Basic #99-103575BP	Two Story SFR - 1997 UBC	Plan: RH II-15	1999
New	Two Story SFR - 1997 UBC	Plan: RH II-15		1999
New	Two Story SFR - 1997 UBC	Plan RH II-11		1999
New	Two Story SFR - 1997 UBC	Plan: RH II-4		1999
New	Approved Basic #99-103205BP	Two Story SFR - 1997 UBC	Plan RH II-5	1999
New	Approved Basic #99-110386 BP	Plan: Hawthorne	Rambler style SFF	1999
New	Approved Basic #99-109533 BP	Rambler w/attached 2-car garage....1997 UBC	Plan No	1999
New	Approved Basic #99-109533 BP	Rambler w/attached 2-car garage....1997 UBC	Plan No	1999
New	Approved Basic #98-110563BP	Plan 2146	Two Story SFR - 1997 UBC	1999

Accessory Dwelling Units

Index # - File Name: 1.0022 - Single Family Dwellings Data\_Snohomish County.pdf

New	Approved Basic #98-110563BP	Plan 2146 Two Story SFR - 1997 UBC	1999
New	Approved Basic #99-110386 BP	Plan: Hawthorne Rambler style SFR	1999
New	Approved Basic #99-109533 BP	Rambler w/attached 2-car garage....1997 UBC	1999
New	Approved Basic #98-110563BP	Plan 2146 Two Story SFR - 1997 UBC	1999
New	Approved Basic #98-110563BP	Plan 2146 Two Story SFR - 1997 UBC	1999
New	Approved Basic #99-104973BP	Plan: Cloverdale Rambler Style SFR - :	1999
New	Approved Basic #99-104574BP	Plan: Kirkwood Rambler Style SFR	1999
New	Approved Basic #99-104574BP	Plan: Kirkwood Rambler Style SFR	1999
New	Approved Basic #99-104973BP	Plan: Cloverdale Rambler Style SFR - :	1999
New	Approved Basic #99-104694BP	Plan: Georgetown Two Story SFR - 199	1999
New	Approved Basic #99-104694BP	Plan: Georgetown Two Story SFR - 199	1999
New	Approved Basic #99-104973BP	Plan: Cloverdale Rambler Style SFR - :	1999
New	Approved Basic #99-104694BP	Plan: Georgetown Two Story SFR - 199	1999
New	Approved Basic #99-104973BP	Plan: Cloverdale Rambler Style SFR - :	1999
New	Approved Basic #99-104574BP	Plan: Kirkwood Rambler Style SFR	1999
New	Approved Basic #99-104973BP	Plan: Cloverdale Rambler Style SFR - :	1999
New	Approved Basic #99-104574BP	Plan: Kirkwood Rambler Style SFR	1999
New	Approved Basic #99-104574BP	Plan: Kirkwood Rambler Style SFR	1999
New	Approved Basic #99-104973BP	Plan: Cloverdale Rambler Style SFR - :	1999
New	Approved Basic #99-104574BP	Plan: Kirkwood Rambler Style SFR	1999
New	Approved Basic #99-104574BP	Plan: Georgetown Two Story SFR - 199	1999
New	One-story SFR w/attached garage		1999
New	One-story SFR w/attached garage		1999
New	Approved Basic 99-104694BP	Plan: Georgetown Two Story SFR - 1997 UBC	1999
New	Approved Basic #99-104609BP	Plan: The Logan Rambler Style SFR - 19	1999
New	Approved Basic #99-104973BP	Plan: Cloverdale Rambler Style SFR - :	1999
New	Approved Basic #99-104574BP	Rambler Style SFR - 1997 UBC	1999
New	Approved Basic #99-104574BP	Rambler Style SFR - 1997 UBC	1999
New	Approved Basic 99-104694BP	Plan: Georgetown Two Story SFR - 1997 U	1999
New	Approved Basic #99-104574BP	Rambler Style SFR - 1997 UBC	1999
New	1463 sf SFR with attached two car garage.		1999
New	1597sf SFR with attached two car garage		1999
New	Approved Basic #99-104973BP	Plan: Cloverdale Rambler Style SFR - :	1999
New	Approved Basic #99-104609BP	Plan: The Logan Rambler Style SFR - 19	1999
New	Approved Basic #99-104609BP	Plan: The Logan Rambler Style SFR - 19	1999
New	Approved Basic #99-104609BP	Plan: The Logan Rambler Style SFR - 19	1999
New	Approved Basic 99-104694BP	Plan: Georgetown Two Story SFR - 1997 UBC	1999
New	Approved Basic #99-104609BP	Plan: The Logan Rambler Style SFR - 19	1999
New	Approved Basic 99-104694BP	Plan: Georgetown Two Story SFR - 1997 UBC	1999
New	Approved Basic #99-104609BP	Plan: The Logan Rambler Style SFR - 19	1999
New	Approved Basic #99-104609BP	Plan: The Logan Rambler Style SFR - 19	1999
New	Approved Basic #99-109533 BP	Rambler w/attached 2-car garage....1997 UBC	1999
New	Approved Basic #98-110563 BP	Rambler w/attached 2-car garage....1997 UBC	1999
New	Approved Basic #98-110563BP	Plan 2146 Two Story SFR - 1997 UBC	1999
New	Approved Basic #98-110563BP	Plan 2146 Two Story SFR - 1997 UBC	1999
New	Approved Basic #99-109533 BP	Rambler w/attached 2-car garage....1997 UBC	1999
New	Approved Basic #98-110563BP	Plan 2146 Two Story SFR - 1997 UBC	1999



Accessory Dwelling Units

Index # - File Name: 1.0022 - Single Family Dwellings Data\_Snohomish County.pdf

New	Rambler Style SFR with attached garage - 1997 UBC		1999
New	Approved Basic #98-110563BP	Plan 2146 Two Story SFR - 1997 UBC	1999
New	Two Story SFR - 1997 UBC	Plan: 4002	1999
New	Two Story SFR - 1997 UBC	Plan: 5023/5123 w/bonus rm	1999
New	Approved Basic #99-105233BP Two Story SFR - 1997 UBC	Plan: RH II-17	1999
New	2 story sfr with 3 car garage		1999
New	2136 sq ft Rambler w/attached 3-car garage.....1997 UBC		1999
New	Approved Basic #99-103342BP	Plan: 5222 Two Story SFR - 1997	1999
New	Approved Basic #99-103349BP	Plan: 5318 Two Story SFR - 1997	1999
New	Approved Basic #99-103832BP	Plan: 4003 Two Story SFR - 1997	1999
New	Approved Basic #99-101214 BP Two Story SFR w/bonus rm - 1997 UBC		1999
New	Approved Basic #99-103574 BP	Plan: 4002 Two Story SFR - 1997 UBC	1999
New	Approved Basic #99-101211BP Two Story SFR - 1997 UBC	Plan:	1999
New	Approved Basic #99-103832BP	Plan: 4003 Two Story SFR - 1997 UB	1999
New	Approved Basic #99-109707 BP	Plan: 5124 Two Story SFR - 1997 UBC	1999
New	Two Story SFR - 1997 UBC	Plan: 4204/4304	1999
New	Approved Basic #99-103832BP	Plan: 4003 Two Story SFR - 1997	1999
New	Approved Basic #99-103574BP	Plan: 4002 Two Story SFR - 1997 UB	1999
New	Approved Basic #99-109707 BP	Plan: 5124 Two Story SFR - 1997 UBC	1999
New	Approved Basic #99-103342 BP Two Story SFR - 1997 UBC	Plan:	1999
New	Approved Basic #99-103349BP	Plan: 5318 Two Story SFR - 1997	1999
New	Approved Basic #99-103347BP	Plan: 4001 Two Story SFR - 1997	1999
New	Approved Basic #99-103574BP	Plan: 4002 Two Story SFR - 1997 UB	1999
New	Two Story SFR with Attached Garage - 1997 UBC		1999
New	Two Story SFR with Attached Garage - 1997 UBC		1999
New	Two Story SFR - 1997 UBC	Plan: 5022/5322 bonus rm	1999
New	Approved Basic #99-109707 BP	Plan: 5124 Two Story SFR - 1997 UBC	1999
New	Approved Basic #99-103349BP	Plan: 5318 Two Story SFR - 1997	1999
New	Approved Basic #99-101212BP Two Story SFR - 1997 UBC	Plan:	1999
New	Approved Basic #99-103349BP	Plan: 5318 Two Story SFR - 1997	1999
New	Two Story SFR - 1997 UBC	Plan: 5223/5323 w/bonus rm	1999
New	Approved Basic #99-103349BP	Plan: 5318 Two Story SFR - 1997	1999
New	Approved Basic #99-101212BP Two Story SFR - 1997 UBC	Plan:	1999
New	Approved Basic #99-101211BP Two Story SFR - 1997 UBC	Plan:	1999
New	Two Story SFR - 1997 UBC	Plan: 5124	1999
New	Approved Basic #99-103347BP	Plan: 4001 Two Story SFR - 1997	1999
New	Approved Basic #99-103347BP	Plan: 4001 Two Story SFR - 1997	1999
New	Approved Basic #99-114150 BP	Plan: 5622 w/bonus Two Story S	1999
New	Approved Basic #99-114271 BP	Plan: 4202 B/C Two Story SFR -	1999
New	Two Story SFR - 1997 UBC	Plan: Chelsea III-A	1999
New	Approved Basic #99-103724BP	Plan: Chelsea III-A Two Story SFR - 19	1999
New	Rambler Style SFR with attached garage		1999
New	Rambler with Attached Garage		1999
New	Two Story SFR with Attached Garage		1999
New	2-Story SFR w/attached garage.		1999
New	Approved Basic #98-117080BP	Two Story SFR - 1997 UBC	1999
New	Approved Basic #99-103832BP	Plan: 4003 Two Story SFR - 1997	1999

Accessory Dwelling Units

Index # - File Name: 1.0022 - Single Family Dwellings Data\_Snohomish County.pdf

New	Approved Basic #99-103832BP	Plan: 4003	Two Story SFR - 199	1999
New	Approved Basic #99-103574 BP	Plan: 4002	Two Story SFR - 199	1999
New	Two Story SFR - 1997 UBC	Plan: 5122		1999
New	Approved Basic #99-109707 BP	Plan: 5124	Two Story SFR - 1997 UBC	1999
New	Approved Basic #99-101212BP		Two Story SFR - 1997 UBC	Plan: 1999
New	Approved Basic #99-103347BP	Plan: 4001	Two Story SFR - 199	1999
New	Approved Basic #99-103342BP	Plan: 5222	Two Story SFR - 199	1999
New	Approved Basic #99-103832BP	Plan: 4003	Two Story SFR - 199	1999
New	Approved Basic #99-101211BP		Two Story SFR - 1997 UBC	Plan: 1999
New	Approved Basic #99-103348BP	Plan: 5218	Two Story SFR - 199	1999
New	Two Story SFR - 1997 UBC	Plan: 5222/5522		1999
New	Approved Basic #99-103574BP	Plan: 4002	Two Story SFR - 1997 UB	1999
New	Approved Basic #99-101211BP		Two Story SFR - 1997 UBC	Plan: 1999
New	Approved Basic #99-103574BP	Plan: 4002	Two Story SFR - 1997 UB	1999
New	Approved Basic #99-103347BP	Plan: 4001	Two Story SFR - 199	1999
New	Approved Basic #99-103574BP	Plan: 4002	Two Story SFR - 1997 UB	1999
New	Approved Basic #99-103832BP	Plan: 4003	Two Story SFR - 199	1999
New	Approved Basic #99-103574BP	Plan: 4002	Two Story SFR - 1997 UB	1999
New	Two Story SFR - 1997 UBC	Plan: 4003		1999
New	Approved Basic #99-103574BP	Plan: 4002	Two Story SFR - 1997 UB	1999
New	Approved Basic #99-101214BP		Two Story SFR - 1997 UBC	Plan: 1999
New	Approved Basic #99-103574BP	Plan: 4002	Two Story SFR - 1997 UB	1999
New	Approved Basic #99-103347BP	Plan: 4001	Two Story SFR - 199	1999
New	Approved Basic #99-103349BP	Plan: 5318	Two Story SFR - 199	1999
New	Approved Basic #99-101211BP		Two Story SFR - 1997 UBC	Plan: 1999
New	1999 28 x 66 Goldenwest			1999
New	2 story Duplex w/attached garage			1999
New	1381 s.f. rambler with 2 car garage			1999
New	Approved Basic #99-104973BP	Plan: Cloverdale	Rambler Style SFR -	1999
New	Approved Basic #99-104694BP		Two Story SFR - 1997 UBC	1999
New	Approved Basic 99-104694BP	Plan: Georgetown	Two Story SFR - 1997 UE	1999
New	Approved Basic #99-104609BP	Plan: The Logan	Rambler Style SFR - 19	1999
New	Approved Basic #99-104609BP	Plan: The Logan	Rambler Style SFR - 19	1999
New	Approved Basic #99-104694BP		Two Story SFR - 1997 UBC	1999
New	Approved Basic #99-104694BP		Two Story SFR - 1997 UBC	1999
New	2-story SFR w/attached 3-car garage.....1997 UBC			1999
New	Two-story SFR w/attached garage			1999
New	Two-story SFR w/attached garage			1999
New	2 story sfr with 3 car garage			1999
New	2-story SFR w/attached 3-car garage.....1997 UBC	Plan #2265-D		1999
New	2-story SFR w/attached 3-car garage....1997 UBC	Plan # 2130-D		1999
New	Rambler Style SFR - 1997 UBC	Plan: 1197		1999
New	Approved Basic #99-111975 BP	Plan: 1533	Two Story SFR - 199	1999
New	Two Story SFR - 1997 UBC	Plan: #1533	2. Vert E Lat by John I Prise	1999
New	Duplex - two-story SFR w/daylight basement			1999
New	Approved Basic #99-113489 BP	Plan: 99001	Two Story Duplex w/finish	1999
New	1999 28 x 56 Oakwood			1999

Accessory Dwelling Units

Index # - File Name: 1.0022 - Single Family Dwellings Data\_Snohomish County.pdf

New	Approved Basic #98-150696BP	Plan: 1922 Two Story SFR - 1997 UBC	1999
New	Rambler w/daylight basement & indoor swimming pool in basement & 2 car garage		1999
New	Two-story SFR w/attached garage....1997 UBC		1999
New	2 story SFR with attached garage		1999
New	2 Story SFR with attached garage and covered porch - 1997 UBC		1999
New	Two Story SFR - 1997 UBC	Plan: 2592 C	1999
New	Approved Basic #98-110372BP	Two Story SFR - 1997 UBC	Plan: #257 1999
New	Approved Basic #98-109885BP	Two Story SFR - 1997 UBC	Plan: #299 1999
New	Approved Basic #99-103251BP	Plan: 2747 - Elevation A Two Story SFR	1999
New	Approved Basic #98-109883BP	Two Story SFR - 1997 UBC	Plan: #244 1999
New	Two Story SFR - 1997 UBC	Plan: 2592 B	1999
New	Approved Basic #99-110099 BP	Plan: 2148 Elev. A Two Story SFR - 1997 U	1999
New	Approved Basic #98-109885BP	Two Story SFR - 1997 UBC	Plan: #299 1999
New	Approved Basic #98-110372BP	Two Story SFR - 1997 UBC	Plan: #257 1999
New	Approved Basic #98-109885BP	Two Story SFR - 1997 UBC	Plan: #299 1999
New	Approved Basic #98-110372BP	Two Story SFR - 1997 UBC	Plan: #257 1999
New	Approved Basic #98-109883BP	Two Story SFR - 1997 UBC	Plan: #244 1999
New	1647 sf SFR with attached two car garage.		1999
New	Approved Basic 99-112317-BP	Bldrs. Plan #1647 Two Story SFR 1997-UBC	1999
New	1554 sf SFR with attached two car garage.		1999
New	Approved Basic 99-112322-BP	BLDRS. PLAN #1554. 2-Story SFR 1997-UBC	1999
New	Approved Basic 99-112317-BP	Bldrs. Plan #1647 Two Story SFR 1997-UBC	1999
New	Approved Basic 99-112322-BP	BLDRS. PLAN #1554. Two Story SFR 1997-L	1999
New	Approved Basic 99-112317-BP	Bldrs. Plan #1647 2-Story SFR 1997-UBC	1999
New	Approved Basic 99-112317-BP	Bldrs. Plan #1647 2-Story SFR 1997-UBC	1999
New	Approved Basic 99-112322-BP	BLDRS. PLAN #1554. Two Story SFR 1997-L	1999
New	2 Story w/2 Car		1999
New	2-Story SFR w/attached garage.		1999
New	2-Story over daylight basement SFR w/attached garage.		1999
New	Approved Basic No. 99-115245 BP	Ramber w/attached 2-car garage...1997 UBC	Plan No 1999
New	2-story SFR w/attached 2-car garage....1997 UBC	Bldrs Plan No. 2765 A/B	1999
New	Approved Basic 99 114776 BP	Builders Plan 2765-A Two-story SFR	1999
New	Two Story SFR - 1997 UBC	Plan: #1990	1999
New	2 story sfr w/2 car garage		1999
New	Approved Basic #98-110724BP	Two Story SFR - 1997 UBC	Plan 1999
New	1471 s.f. rambler with 2 car garage		1999
New	Approved Basic #98-110724BP	Two Story SFR - 1997 UBC	Plan 1999
New	Two Story SFR with Attached Garage -		1999
New	2 Story w/3 Car	Builders Plan #1800	1999
New	Approved Basic #99-112039 BP	Plan: 2002 Two Story SFR - 1997 UBC	1999
New	Approved Basic 99-111773 BP	2 Story w/3 Car	Builders Plan # 1999
New	STOP WORK ORDER POSTED 09/28/99 GS - TESC & GRAD W/OUT PERMIT	Approved Basic #99-	1999
New	Approved Basic #99-112268 BP	Plan: 1990 Two Story SFR - 1997 UBC	1999
New	Rambler w/attached 2-car garage....1997 UBC		1999
New	Approved Basic #99-114460 BP	2-story SFR w/attached 2-car garage.....1997 UBC	Bldrs F 1999
New	Approved Basic #99-113070 BP	Plan #2083 Two Story SFR - 1997 UBC	1999
New	2 story SFR with attached garage		1999

Accessory Dwelling Units

Index # - File Name: 1.0022 - Single Family Dwellings Data\_Snohomish County.pdf

New	Approved Basic #99-112268 BP	Plan: 1990 Two Story SFR - 1997 UE	1999
New	Rambler with Attached Garage		1999
New	Approved Basic 99-111773 BP 2 Story w/3 Car	Builder:	1999
New	2 Story SFR w/2 Car garage.		1999
New	Approved Basic #99-111968	Bldrs. Plan #2204 2-Story SFR w/at	1999
New	Approved Basic #99-111968	Bldrs. Plan #2204 2-Story SFR w/at	1999
New	Approved Basic #99-112141 BP	Bldrs. Plan: Mt Raineer Two Story SFR - 199	1999
New	Approved Basic #98-110003BP	Plan: Wycliffe Crest Two-story SFR w/att	1999
New	Approved Basic #98-107594BP	Plan #2211-B Two Story SFR w/	1999
New	Approved Basic #98-107594BP	Plan #2211-B Two Story SFR w/	1999
New	2-Story SFR w/attached garage.		1999
New	2 story sfr with 3 car garage.1997 UBC		1999
New	Two-story SFR with Attached Garage	Builders Plan 2258B	1999
New	2-story SFR w/attached 2-car garage on basement level...1997 UBC	Builder s Plan No. 2163 B	1999
New	2-Story SFR w/attached garage.		1999
New	Approved Basic 99-114133 BP	Plan #2163BA 2-story SFR w/a	1999
New	Approved Basic #99-112039 BP	Plan: 2002 Two Story SFR - 1997 U	1999
New	2 Story w/2 Car		1999
New	2 - Story with attached garage - 1997 UBC		1999
New	2-Story SFR with Attached Garage.		1999
New	1997-UBC 1997-WSEC		1999
New	Approved Basic #98-109410BP	Plan: 1644 Split Level SFR - 1997 U	1999
New	Approved Basic #99-101587BP 2 Story SFR/ 2 car garage	Plan #	1999
New	Approved Basic #98-109408BP	Plan: 1705 SFR w/unfinished lower	1999
New	Approved Basic #98-109410BP	Plan: 1644 Split Level SFR - 1997 U	1999
New	Approved Basic #99-101587BP 2 Story SFR/ 2 car garage	Plan #	1999
New	Approved Basic #99-101345BP	Plan: 1352 SFR w/unfinished ba:	1999
New	Approved Basic #98-109410BP	Plan: 1644 Split Level SFR - 1997 U	1999
New	Approved Basic #99-101587BP 2 Story SFR/ 2 car garage	Plan #	1999
New	Approved Basic #98-109408BP	Plan: 1705 SFR w/unfinished lower	1999
New	Approved Basic #99-101345BP	Plan: 1352 SFR w/unfinished ba:	1999
New	Approved Basic #98-109408BP	Plan: 1705 SFR w/unfinished lower	1999
New	Approved Basic #98-109410BP	Plan: 1644 Split Level SFR - 1997 U	1999
New	Approved Basic #99-101587BP 2 Story SFR/ 2 car garage	Plan #	1999
New	Approved Basic #98-109410BP	Plan: 1644 Split Level SFR - 1997 U	1999
New	Approved Basic #99-101587BP 2 Story SFR/ 2 car garage	Plan #	1999
New	Approved Basic #98-109408BP	Plan: 1705 SFR w/unfinished lower	1999
New	Approved Basic #99-101587BP 2 Story SFR/ 2 car garage	Plan #	1999
New	Approved Basic #99-101345BP	Plan: 1352 SFR w/unfinished ba:	1999
New	Approved Basic #98-109410BP	Plan: 1644 Split Level SFR - 1997 U	1999
New	Approved Basic #98-109410BP	Plan: 1644 Split Level SFR - 1997 U	1999
New	Approved Basic #98-109408BP	Plan: 1705 SFR w/unfinished lower	1999
New	Approved Basic #99-101587BP 2 Story SFR/ 2 car garage	Plan #	1999
New	Approved Basic #98-109410BP	Plan: 1644 Split Level SFR - 1997 U	1999
New	Approved Basic #99-101345BP	Plan: 1352 SFR w/unfinished ba:	1999
New	Approved Basic #98-109408BP	Plan: 1705 SFR w/unfinished lower	1999
New	Approved Basic #99-101587BP 2 Story SFR/ 2 car garage	Plan #	1999

Accessory Dwelling Units

Index # - File Name: 1.0022 - Single Family Dwellings Data\_Snohomish County.pdf

New	Ramber w/attached 3-car garage....1997 UBC		1999
New	Ramber w/attached 3-car garage....1997 UBC		1999
New	Ramber w/bonus room over the 2-car garage....1997 UBC		1999
New	2 story sfr w/ attached 3 car garage		1999
New	Rambler Style SFR - 1997 UBC	Plan: 2135	1999
New	Two Story SFR - 1997 UBC	Plan: 2330	1999
New	Approved Basic #98-116802BP	Two Story Duplex - 1997 UBC	1999
New	Approved Basic #99-114266 BP 2-story Duplex...1997 UBC		Bldr: 1999
New	Approved Basic #99-110870 BP	Plan: Chantell Two Story Duplex - 1997 UBC	1999
New	Approved Basic #98-116802BP	Two Story Duplex - 1997 UBC	1999
New	NOTICE NON-OCCUPANCY, PER T. BRYANT, 1/21/00. Approved Basic #99-110870 BP		1999
New	Two Story Duplex - 1997 UBC	Plan: San Juan	1999
New	Approved Basic #98-116802BP	Two Story Duplex - 1997 UBC	1999
New	28 x 44 1989 Fleetwood		1999
New	1999 40 x 66 Oakwood		1999
New	New two story with attached three car garage.		1999
New	2164 s.f. rambler with 2 car garage		1999
New	2 story SFR w/ attached garage		1999
New	Approved Basic #99-103130BP	Plan: 1491 Two Story SFR - 1997 U	1999
New	Approved Basic #99-109632 BP	Elevation A Two Story SFR - 1997 UBC	1999
New	2 story SFR with attached garage - 1997 UBC		1999
New	Approved Basic #99-109767 BP	Plan: 1256 (front-load) Split Level SFR	1999
New	Approved Basic #99-103130BP	Plan: 1491 Two Story SFR - 1997 U	1999
New	2 story SFR w/ attached garage Plan #1484		1999
New	Approved Basic #99-103130BP	Plan: 1491 Two Story SFR - 1997 U	1999
New	Approved Basic #99-103127BP	Plan: 1558 B Two Story SFR - 1997 UBC	1999
New	Approved Basic #99-109767 BP	Plan: 1256 (front-load) Split Level SFR	1999
New	Approved Basic #99-103130BP	Plan: 1491 Two Story SFR - 1997 U	1999
New	2 story SFR w/ attached garage		1999
New	Approved Basic #99-103127BP	Plan: 1558 B Two Story SFR - 1997 UBC	1999
New	Approved Basic #99-103127 BP	Plan: 1558 B Two Story SFR - 1997 UBC	1999
New	Approved Basic #99-103130BP	Plan: 1491 Two Story SFR - 1997 U	1999
New	Two Story SFR - 1997 UBC	Plan: 1621	1999
New	Two-story SFR w/attached garage - 1997 UBC	Plan 1533	1999
New	Two Story SFR - 1997 UBC	Plan: 1621	1999
New	2-story SFR w/attached 2-car garage....1997 UBC		1999
New	Split Level SFR - 1997 UBC	Plan: 1438	1999
New	Split Level SFR - 1997 UBC	Plan: 1438	1999
New	Split Level SFR - 1997 UBC	Plan: 1438	1999
New	Two-story SFR w/attached garage - 1997 UBC	Builder Plan 1621	1999
New	Two-story SFR w/attached garage - 1997 UBC	Plan 1533	1999
New	Approved Basic #99-104638BP	Plan: 2274 Rambler Style SFR - 1997	1999
New	Approved Basic #99-109776 BP	Plan: 2397 w/bonus Two Story SFR -	1999
New	Approved Basic #99-112673 BP	Plan: 3272 Two Story SFR - 1997 UBC	1999
New	Approved Basic #99-109776 BP	Plan: 2397 w/bonus Two Story SFR -	1999
New	Approved Basic #99-109776 BP	Plan: 2397 w/bonus Two Story SFR -	1999
New	2-story SFR w/attached 3-car garage....1997 UBC	Plan # 3063	1999

Accessory Dwelling Units

Index # - File Name: 1.0022 - Single Family Dwellings Data\_Snohomish County.pdf

New	Approved Basic #99-110798 BP	Plan: 1549	Rambler Style SFR - 1997 UB	1999
New	Approved Basic #99-110798 BP	Plan: 1549	Rambler Style SFR - 1997 UB	1999
New	Approved Basic #99-110798 BP	Plan: 1549	Rambler Style SFR - 1997 UB	1999
New	Split Entry Style SFR w/basement garage.			1999
New	28 x 48 - 1991 Fleetwood			1999
New	Two-story SFR w/unfin basement			1999
New	Two-story SFR w/attached garage			1999
New	Approved Basic #99-110798 BP	Plan: 1549	Rambler Style SFR - 1997 UB	1999
New	Rambler Style SFR - 1997 UBC	Builders Plan 1549		1999
New	Approved Basic #99-110798 BP	Plan: 1549	Rambler Style SFR - 1997 UB	1999
New	2527 sf 2-story w/612 sf garage and 210 sf covered deck/porch			1999
New	14 x 60 1979 Skyline			1999
New	Rambler w/2 Car			1999
New	1951 sq ft Ramber w/covered varanda s....1997 UBC			1999
New	1999 Oakwood 41 x 66			1999
New	2 Story w/2 Car			1999
New	26.5 x 60 1999 Marlette			1999
New	SFR with Attached Garage			1999
New	One-story SFR w/attached garage			1999
New	2129 sf 2-story w/512 sf garage and 72 sf covered deck/porch and 120 sf open deck			1999
New	Approved Basic #99-111665 BP Mid-entry SFR w/attached 2-car garage.....1997 UBC			1999
New	2-Story SFR w/attached garage			1999
New	Approved Basic #99-109597 BP Two Story SFR - 1997 UBC		Plan:	1999
New	SFR w/finished lower floor - 1997 UBC			1999
New	Approved Basic 99105003 BP	Builders Plan 9410-A	Two-story SFR w/	1999
New	2000 Ambercove 6419 40 x 48			1999
New	1999 41 x 68 Redmond			1999
New	2421 sf rambler w/484 sf garage and 200 sf covered porch and 200 sf open deck			1999
New	Approved Basic #99-109597 BP Two Story SFR - 1997 UBC		Plan:	1999
New	Approved Basic #99-109597 BP Two Story SFR - 1997 UBC		Plan:	1999
New	Approved Basic #99-111932 BP	Plan: 1827	Split Level SFR - 19	1999
New	Split-Entry Style SFR w/attached garage.			1999
New	Approved Basic #99-109597 BP Two Story SFR - 1997 UBC		Plan:	1999
New	2000 28 x 66 Oakwood			1999
New	SFR with 392 sf Bonus Room and Attached Garage			1999
New	Two Story SFR with Attached Garage			1999
New	Two Story SFR with Finished Basement and Attached Garage			1999
New	2-Story SFR w/attached garage	1997-UBC		1999
New	2-Story SFR w/attached garage.	1997-UBC		1999
New	2-Story SFR w/attached garage.			1999
New	2-story SFR w/attached garage.			1999
New	2-Story SFR w/attached garage.			1999
New	Approved Basic #98-110003BP	Plan: Wycliffe Crest	Two-story SFR w/att	1999
New	Approved Basic #98-110003BP	Plan: Wycliffe Crest	Two-story SFR w/att	1999
New	Approved Basic #99-109597 BP Two Story SFR - 1997 UBC		Plan:	1999
New	Approved Basic #99-114464 BP 2-story SFR w/attached 3-car garage....1997 UBC		Bldr P	1999
New	Approved Basic 99113070BP	Plan: 2083	Two Story SFR - 1997 UB	1999

Accessory Dwelling Units

Index # - File Name: 1.0022 - Single Family Dwellings Data\_Snohomish County.pdf

New	2967 sf 2-story w/693 sf garage and 155 sf covered deck/porch		1999
New	Approved Basic #99-113908 BP	Plan: 212-3 Split Level SFR - 1997 U	1999
New	Split Entry Style SFR w/ Finished Basement & Basement Garage.		1999
New	Approved Basic #99-102550BP	Plan: 2064 Rambler Style SFR - 1997	1999
New	Approved Basic #99-102547BP	Plan: 1484 Two Story SFR - 1997 UBC	1999
New	Approved Basic #99-102547BP	Plan: 1484 Two Story SFR - 1997 UBC	1999
New	Approved Basic #99-102547BP	Plan: 1484 Two Story SFR - 1997 UBC	1999
New	Approved Basic #99-102547BP	Plan: 1484 Two Story SFR - 1997 UBC	1999
New	Approved Basic #99-102547BP	Plan: 1484 Two Story SFR - 1997 UBC	1999
New	Approved Basic #99-102547BP	Plan: 1484 Two Story SFR - 1997 UBC	1999
New	Approved Basic #99-102547BP	Plan: 1484 Two Story SFR - 1997 UBC	1999
New	Approved Basic #99-102547BP	Plan: 1484 Two Story SFR - 1997 UBC	1999
New	Two-story SFR w/ basement & attached garage		1999
New	Approved Basic #98-110723BP	Two Story SFR - 1997 UBC	Plan 1999
New	Approved Basic #98-110722BP	Two Story SFR - 1997 UBC	Plan #22 1999
New	Approved Basic #98-110723BP	Two Story SFR - 1997 UBC	Plan 1999
New	Approved Basic #98-110722BP	Two Story SFR - 1997 UBC	Plan #22 1999
New	Approved Basic #98-110723BP	Two Story SFR - 1997 UBC	Plan 1999
New	2-Story SFR w/attached garage.		1999
New	1999 27 x 44 Fuller Bay Mobile Home		1999
New	Approved Basic #99-112379 BP	Plan #2417 Two Story SFR - 1997 UBC	1999
New	Approved Basic #99-112379 BP	Plan #2417 Two Story SFR - 1997 UBC	1999
New	Two Story SFR - 1997 UBC	Plan: 2203	1999
New	Two Story SFR - 1997 UBC	Plan: 2350	1999
New	Approved Basic #99-113793 BP	Plan: 2203 Two Story SFR - 1997 U	1999
New	Approved Basic #99-113792 BP	Plan: 2350 Two Story SFR - 1997 UE	1999
New	2 story sfr with 2 car garage		1999
New	Approved Basic #99-112379 BP	Plan #2417 Two Story SFR - 1997 UBC	1999
New	Approved Basic #99-113793 BP	Plan: 2203 Two Story SFR - 1997 U	1999
New	Approved Basic #99-115762 BP	Builders Plan 2005 Two-story SFR - 1997 U	1999
New	Two Story SFR - 1997 UBC	Plan: 2005	1999
New	1999 Valley Cottage 26 x 44 MH		1999
New	One-story SFR w/attached garage		1999
New	Approved Basic #99-102550BP	Plan: 2064 Rambler Style SFR - 1997	1999
New	2-story SFR w/attached 3-car garage...1997 UBC		1999
New	28 x 56 DW MH in Park		1999
New	New two story with attached one car garage.		1999
New	One-story SFR w/unfinished basement & attached garage. ***STOP WORK, 12/14/99 - POSTED		1999
New	New one story SFR with attached three-car garage.		1999
New	Approved Basic #98-110504BP	Plan #2195 Split Level SFR - 1997 UBC	1999
New	Two-story SFR with semi/unfin basement & attached garage		1999
New	2-Story SFR w/attached garage.		1999
New	2-Story SFR w/attached garage.		1999
New	2-Story SFR w/attached garage.		1999
New	Approved Basic 99-113600BP	Plan: #2578 Two Story SFR - 1997 UBC	1999
New	Rambler style SFR w/attached garage.		1999
New	Rambler Style SFR with attached garage 1997 - UBC		1999

Accessory Dwelling Units

Index # - File Name: 1.0022 - Single Family Dwellings Data\_Snohomish County.pdf

New	Approved Basic #98-106862BP	(4 Bedroom w/opt. 5th bedroom)	Two Story SFI	1999
New	Approved Basic #98-106866BP	(3 Bedroom)	Two Story SFR - 1997 UBC	1999
New	Approved Basic #98-106865BP	(5 Bedroom)	Two Story SFR - 1997 UBC	1999
New	Approved Basic #98-106869BP		Plan #2216 Two Story SFR - 1997 UBC	1999
New	Approved Basic #98-106871BP	Two Story SFR - 1997 UBC		1999
New	Approved Basic #98-106867BP	(4 Bedroom)	Two Story SFR - 1997 UBC	1999
New	Approved Basic #98-106859BP		Plan #1607 Two Story SFR - 1997 UBC	1999
New	Approved Basic #98-106869BP		Plan #2216 Two Story SFR - 1997 UBC	1999
New	Approved Basic #98-106871BP	Two Story SFR - 1997 UBC		1999
New	Approved Basic #98-106867BP	(4 Bedroom)	Two Story SFR - 1997 UBC	1999
New	Approved Basic #98-106862BP	(4 Bedroom w/opt. 5th bedroom)	Two Story SFI	1999
New	Approved Basic #98-106867BP	(4 Bedroom)	Two Story SFR - 1997 UBC	1999
New	Approved Basic #98-106871BP	Two Story SFR - 1997 UBC		1999
New	Approved Basic #98-106869 BP	Two Story SFR - 1997 UBC		1999
New	Approved Basic #98-106859BP		Plan #1607 Two Story SFR - 1997 UBC	1999
New	Approved Basic #98-106867BP	(4 Bedroom)	Two Story SFR - 1997 UBC	1999
New	Approved Basic #98-106865BP	(5 Bedroom)	Two Story SFR - 1997 UBC	1999
New	Approved Basic #98-106859BP		Plan #1607 Two Story SFR - 1997 UBC	1999
New	Approved Basic #98-106865BP	(5 Bedroom)	Two Story SFR - 1997 UBC	1999
New	Approved Basic #98-106871BP	Two Story SFR - 1997 UBC		1999
New	Approved Basic #98-106867BP	(4 Bedroom)	Two Story SFR - 1997 UBC	1999
New	Approved Basic #98-106859BP		Plan #1607 Two Story SFR - 1997 UBC	1999
New	Approved Basic #98-106869BP		Plan #2216 Two Story SFR - 1997 UBC	1999
New	Approved Basic #98-106867BP	(4 Bedroom)	Two Story SFR - 1997 UBC	1999
New	Approved Basic #98-106862BP	(4 Bedroom w/opt. 5th bedroom)	Two Story SFI	1999
New	Approved Basic #98-106871BP	Two Story SFR - 1997 UBC		1999
New	Approved Basic #98-106871BP	Two Story SFR - 1997 UBC		1999
New	Approved Basic #98-106862BP	(4 Bedroom w/opt. 5th bedroom)	Two Story SFI	1999
New	Approved Basic #98-106867BP	(4 Bedroom)	Two Story SFR - 1997 UBC	1999
New	Approved Basic #98-106859BP		Plan #1607 Two Story SFR - 1997 UBC	1999
New	Approved Basic #98-106869BP		Plan #2216 Two Story SFR - 1997 UBC	1999
New	Approved Basic #98-106871BP	Two Story SFR - 1997 UBC		1999
New	Approved Basic #98-106867BP	(4 Bedroom)	Two Story SFR - 1997 UBC	1999
New	Approved Basic #98-106859BP		Plan #1607 Two Story SFR - 1997 UBC	1999
New	Approved Basic #98-106867BP	(4 Bedroom)	Two Story SFR - 1997 UBC	1999
New	Approved Basic #98-106866BP	(3 Bedroom)	Two Story SFR - 1997 UBC	1999
New	Approved Basic #98-106871BP	Two Story SFR - 1997 UBC		1999
New	Approved Basic #98-106869BP		Plan #2216 Two Story SFR - 1997 UBC	1999
New	Approved Basic #98-106871BP	Two Story SFR - 1997 UBC		1999
New	Approved Basic #98-106867BP	(4 Bedroom)	Two Story SFR - 1997 UBC	1999
New	Approved Basic #98-106865BP	(5 Bedroom)	Two Story SFR - 1997 UBC	1999
New	Approved Basic #98-106866BP	(3 Bedroom)	Two Story SFR - 1997 UBC	1999
New	Two Story SFR - 1997 UBC	Plan: WAS 99-22		1999
New	1549 s.f. rambler w/2 car garage			1999



Accessory Dwelling Units

Index # - File Name: 1.0022 - Single Family Dwellings Data\_Snohomish County.pdf

New	37 X 60 1992 Fuqua		1999
New	66 x 28 - 1999 - Redman		1999
New	Two Story SFR - 1997 UBC	Plan: 1833	1999
New	Two Story SFR - 1997 UBC		1999
New	Approved Basic #98-109153BP	Plan 2031 Two Story SFR - 1997 UI	1999
New	Two Story SFR - 1997 UBC	Plan: 2031 3-car	1999
New	Approved Basic #99-112089 BP	Plan: 2031 Two Story SFR - 1997 U	1999
New	Two Story SFR - 1997 UBC		1999
New	Two Story SFR w/unfinished basement - 1997 UBC	Plan: 2031	1999
New	Two-story SFR w/finished basement	Summer Ridge 8	1999
New	Approved Basic #98-109153BP	Plan 2031 Two Story SFR - 1997 UI	1999
New	Two Story SFR - 1997 UBC	Plan: 2802 B/3SG	1999
New	Two Story SFR - 1997 UBC	Plan: 1802 B/3SG	1999
New	Approved Basic #99-112583 BP	Builders Plan 3025 A Two Story SFR - 1997	1999
New	Approved Basic #99-112585 BP	Builders Plan 3105 D Two Story SFR -	1999
New	24 x 64 1984 Silver Crest		1999
New	Approved Basic #98-109993BP	Builders #1715 2-Story SFR w/attached g	1999
New	Approved Basic #98-110348BP	Plan #2005 Two Story SFR - 1997 U	1999
New	Approved Basic #98-109993BP	Builders #1715 2-Story SFR w/attached g	1999
New	Approved Basic #98-110348BP	Plan #2005 Two Story SFR - 1997 U	1999
New	Approved Basic #98-109993BP	Builders #1715 2-Story SFR w/attached g	1999
New	Approved Basic #98-110356BP	Plan #2093 Two Story SFR - 1997 UBC	1999
New	Approved Basic #98-109993BP	Builders #1715 2-Story SFR w/attached g	1999
New	Approved Basic #98-116958BP	PLAN#1732 2-Story SFR w/attache	1999
New	Approved Basic #98-110356BP	Plan #2093 Two Story SFR - 1997 UBC	1999
New	Approved Basic #98-110348BP	Plan #2005 Two Story SFR - 1997 U	1999
New	Two Story SFR - 1997 UBC	Plan: 1862	1999
New	Approved Basic #98-109993BP	Builders #1715 2-Story SFR w/attached g	1999
New	Approved Basic #98-116958BP	PLAN#1732 2-Story SFR w/attache	1999
New	Approved Basic #98-109993BP	Builders #1715 2-Story SFR w/attached g	1999
New	Approved Basic #98-109993BP	Builders #1715 2-Story SFR w/attached g	1999
New	Approved Basic #98-109993BP	Builders #1715 2-Story SFR w/attached g	1999
New	2 Story w/ 2 Car		1999
New	Mid-Entry Style SFR w/fin. basement/garage.		1999
New	Approved Basic #98-110213BP	Plan #1333 Two Story Duplex - 1997	1999
New	Two-story SFR w/attached garage	Builder Plan 2461	1999
New	Rambler Style SFR - 1997 UBC	Plan: 1649	1999
New	Approved Basic #98-150960BP Two Story SFR - 1997 UBC		Plan: 2329 1999
New	Two Story SFR - 1997 UBC	Plan: Avalon/2164	1999
New	2-Story SFR w/attached garage.		1999
New	Two Story SFR - 1997 UBC	Plan: Waterbrooke/2043	1999
New	Two Story SFR - 1997 UBC	Plan: 2390	1999
New	Two Story SFR - 1997 UBC	Plan: 2415	1999
New	Approved Basic #98-107885BP	Plan: #1908/side Two Story SFR - 1997	1999
New	Approved Basic #98-108797BP	Plan 1715 side/load Two Story SFR - 1997 UBC	1999
New	Two Story SFR - 1997 UBC	Plan: 2528	1999
New	Two Story SFR - 1997 UBC	Plan: 2235	1999

Accessory Dwelling Units

Index # - File Name: 1.0022 - Single Family Dwellings Data\_Snohomish County.pdf

New	Approved Basic #99-103777BP	Plan: 2415 A/3	Two Story SFR - 1997	1999
New	Two Story SFR - 1997 UBC	Plan: 2188		1999
New	Approved Basic #99-115230 BP	Plan: 1998	SFR w/finished baser	1999
New	Two Story SFR - 1997 UBC	Plan: #1884		1999
New	Approved Basic #98-150960BP	Two Story SFR - 1997 UBC	Plan: 2329	1999
New	Two-story SFR w/attached 3 car garage			1999
New	Approved Basic #99-103777BP	Plan: 2415 A/3	Two Story SFR - 1997	1999
New	Approved Basic #98-150960BP	Two Story SFR - 1997 UBC	Plan: 2329	1999
New	Two Story SFR - 1997 UBC	Plan: Kensington/2233		1999
New	Two Story SFR - 1997 UBC			1999
New	Approved Basic #99-114983 BP	Plan: 2445	Two Story SFR - 1997 UBC	1999
New	Approved Basic #99-114387 BP	Plan: 2242	Two Story SFR - 1997 U	1999
New	Approved Basic #99-110071 BP	Plan: #2368	Two Story SFR - 1997 UBC	1999
New	28 x 66 1999 Goldenwest			1999
New	Approved Basic #99-113391BP	Plan: 1236	Mid Entry SFR - 1997 UBC	1999
New	Approved Basic #99-113392 BP	Plan: 2220	Mid Entry SFR - 1997 UBC	1999
New	Approved Basic #99-109632 BP	Elevation A	Two Story SFR - 1997 UBC	1999
New	Approved Basic #99-113391BP	Plan: 1236	Mid Entry SFR - 1997 UBC	1999
New	Approved Basic #99-113717 BP	Plan: #2002	Two Story SFR - 1997	1999
New	Approved Basic #99-113392 BP	Plan: 2220	Mid Entry SFR - 1997 UBC	1999
New	Approved Basic #99-113717 BP	Plan: #2002	Two Story SFR - 1997	1999
New	Approved Basic #99-113391BP	Plan: 1236	Mid Entry SFR - 1997 UBC	1999
New	Two Story SFR - 1997 UBC	Plan: Chateau/2342		1999
New	Approved Basic #99-113529 BP	Plan: 1927	Two Story SFR - 1997 UBC	1999
New	Approved Basic #98-116263BP	Plan #2188	Two Story SFR - 1997 UBC	1999
New	Approved Basic #98-116263BP	Plan #2188	Two Story SFR - 1997 UBC	1999
New	2000 28 x 66 GoldenWest			1999
New	Approved Basic #99-114309 BP	Plan: LSA 3459	Rambler Style Duplex - 1	1999
New	Approved Basic #99-110072 BP	Plan: 2265	Two Story SFR - 1997 UBC	1999
New	Approved Basic #99-110071 BP	Plan: #2368	Two Story SFR - 1997 UBC	1999
New	Approved Basic #99-110072 BP	Plan: 2265	Two Story SFR - 1997 UBC	1999
New	Approved Basic #98-109885BP	Two Story SFR - 1997 UBC	Plan: #299	1999
New	Approved Basic #98-109885BP	Two Story SFR - 1997 UBC	Plan: #299	1999
New	Mid-Entry Style SFR w/unfin. basement & basement garage.			1999
New	28x44 (2000) Redman			1999
New	28x40 (2000) Redman			1999
New	One story SFR with attached two car garage.			1999
New	2265 sf 2-story w/648 sf garage, 372 sf covered deck/porch, and 480 sf open deck			1999
New	2450 sf 2-story w/648 sf garage, 372 sf covered deck/porch, and 480 sf open deck			1999
New	Approved Basic #99-114671 BP	Plan: 926 D	Two Story SFR - 1997	1999
New	Approved Basic #99-114666 BP	Plan: F932	Two Story SFR - 1997 U	1999
New	Two Story SFR - 1997 UBC	Plan: 865 A/B		1999
New	Approved Basic #99-114666 BP	Plan: F932	Two Story SFR - 1997 U	1999
New	Approved Basic #99-115559 BP	Plan: 835 AB	Two Story SFR - 1997 UBC	1999
New	Approved Basic #99-114671 BP	Plan: 926 D	Two Story SFR - 1997	1999
New	Two Story SFR -1997 UBC	Plan: 865 AB		1999
New	Approved Basic #99-114666 BP	Plan: F932	Two Story SFR - 1997 U	1999

Accessory Dwelling Units

Index # - File Name: 1.0022 - Single Family Dwellings Data\_Snohomish County.pdf

New	Approved Basic #99-114666 BP	Plan: F932	Two Story SFR - 1997 U	1999
New	Two Story SFR - 1997 UBC	Plan: 6030 FT		1999
New	Two Story SFR - 1997 UBC	Plan: 949 G		1999
New	Approved Basic #99-115502 BP	Plan: 99C-1860	Rambler Style SFR - 1	1999
New	Approved Basic #99-115502 BP	Plan: 99C-1860	Rambler Style SFR - 1	1999
New	Approved Basic #99-115502 BP	Plan: 99C-1860	Rambler Style SFR - 1	1999
New	Approved Basic #99-115502 BP	Plan: 99C-1860	Rambler Style SFR - 1	1999
New	Approved Basic #99-115502 BP	Plan: 99C-1860	Rambler Style SFR - 1	1999
New	Approved Basic #99-115502 BP	Plan: 99C-1860	Rambler Style SFR - 1	1999
New	Duplex Rambler w/ 2 Car Garages			1999
New	Approved Basic #98-109460BP	Plan # A-311 a/b	Two Story SFR - 1997 UB	1999
New	Two Story SFR - 1997 UBC	Plan: 1602		1999
New	Rambler Style SFR - 1997 UBC	Plan: 1452		1999
New	Rambler Style SFR - 1997 UBC	Plan: 1452		1999
New	Rambler Style SFR - 1997 UBC			1999
New	Approved Basic #99-115502 BP	Plan: 99C-1860	Rambler Style SFR - 1997	1999
New	Approved Basic #99-115502 BP	Plan: 99C-1860	Rambler Style SFR - 1	1999
New	Approved Basic #99-115502 BP	Plan: 99C-1860	Rambler Style SFR - 1	1999
New	Approved Basic #99-115502 BP	Plan: 99C-1860	Rambler Style SFR - 1	1999
New	Approved Basic #99-103777BP	Plan: 2415 A/3	Two Story SFR - 1997	1999
New	Approved Basic #98-150960BP	Two Story SFR - 1997 UBC	Plan: 2329	1999
New	Approved Basic #98-109410BP	Plan: 1644	Split Level SFR - 1997 U	1999
New	Approved Basic #99-101587BP	2 Story SFR/ 2 car garage	Plan #	1999
New	Approved Basic #99-101587BP	2 Story SFR/ 2 car garage	Plan #	1999
New	Approved Basic #99-101587BP	2 Story SFR/ 2 car garage	Plan #	1999
New	Approved Basic #98-109408BP	Plan: 1705	SFR w/unfinished lower	1999
New	Approved Basic #98-109410BP	Plan: 1644	Split Level SFR - 1997 U	1999
New	Approved Basic #99-101345BP	Plan: 1352	SFR w/unfinished ba:	1999
New	Approved Basic #98-109408BP	Plan: 1705	SFR w/unfinished lower	1999
New	SFR w/semi-finished lower floor - 1997 UBC	Plan: 1450 S		1999
New	Approved Basic #98-110504BP	Plan #2195	Split Level SFR - 1997 UBC	1999
New	Approved Basic #98-110504BP	Plan #2195	Split Level SFR - 1997 UBC	1999
New	Approved Basic #99-115496 BP	Split SFR w/finished lower floor - 1997 UBC		1999
New	Approved Basic #99-115498 BP	Plan: 1864	Two Story SFR - 1997 U	1999
New	Approved Basic #99-115490 BP	Plan #1905	Two Story SFR - 1997 UBC	1999
New	Approved Basic #99-115498 BP	Plan: 1864	Two Story SFR - 1997 U	1999
New	Approved Basic #98-110504BP	Plan #2195	Split Level SFR - 1997 UBC	1999
New	Approved Basic #98-110504BP	Plan #2195	Split Level SFR - 1997 UBC	1999
New	Approved Basic #98-110504BP	Plan #2195	Split Level SFR - 1997 UBC	1999
New	Approved Basic #99-111975 BP	Plan: 1533	Two Story SFR - 199	1999
New	2 story sfr w/2 car garage. DO NOT FINAL per Gerry Schelbreck 3/31/00. 1. Prior to final buildi			1999
New	Approved Basic #99-111975 BP	Plan: 1533	Two Story SFR - 199	1999
New	2 story sfr w/2 car garage			1999
New	Approved Basic #99-111975 BP	Plan: 1533	Two Story SFR - 199	1999
New	Split Entry w/2 Car Garage			1999
New	Two Story SFR - 1997 UBC	Plan: 1542		1999
New	Tri Level SFR - 1997 UBC	Plan: 1516		1999

Accessory Dwelling Units

Index # - File Name: 1.0022 - Single Family Dwellings Data\_Snohomish County.pdf

New	Two Story SFR - 1997 UBC	Plan: 1557	1999
New	Approved Basic #98-116126BP	Plan 2704 Two Story SFR - 1997 U	1999
New	Approved Basic #98-116126BP	Plan #2704 Two Story SFR - 1997 UBC	1999
New	Approved Basic #98-116126BP	Plan 2704 Two Story SFR - 1997 U	1999
New	Approved Basic #98-116126BP	Plan 2704 Two Story SFR - 1997 U	1999
New	Approved Basic #98-116126BP	Plan #2704 Two Story SFR - 1997 UBC	1999
New	840 s.f. rambler with 2 car garage		1999
New	Approved Basic #00-101627 BP	Plan: 1221 A Two Story SFR - 1997 UBC	2000
New	2-story SFR.....1997 UBC		2000
New	Two-story SFR w/attached garage		2000
New	1993 28x56 Champion		2000
New	1344 sf rambler w/648 sf finished basement and 1020 sf garage		2000
New	Rambler Style Duplex with attached garages/carport.		2000
New	2 story sfr w/2 car garage		2000
New	27 x 66 + 13 x 23 Pod. - 2000 - Oakwood		2000
New	Approved Basic #99-111975 BP	Plan: 1533 Two Story SFR - 1997 UBC	2000
New	Approved Basic #99-111975 BP	Plan: 1533 Two Story SFR - 1997 UBC	2000
New	Approved Basic #99-111975 BP	Plan: 1533 Two Story SFR - 1997 UBC	2000
New	2000 28 x 56 Redmond		2000
New	24 x 59 1982 Sequoia		2000
New	Approved Basic #98-109885BP	OPTION: Approved TJI Two Story SFR - 19	2000
New	Approved Basic #99-110099 BP	Plan: #2148 Elev A Two Story SFR - 1997	2000
New	Approved Basic #00-101970 BP	Plan: #2990 (Elev. B) Two Story SFR - 1997 UBC	2000
New	Approved Basic #00-101971 BP	Plan: #2990 (Elev. C) Two Story SFR - 1997 UBC	2000
New	Approved Basic #00-101972 BP	Plan: #2446 (Elev. A) Two Story SFR - 1997 UBC	2000
New	Approved Basic #00-101969 BP	Plan: #2990 (Elev. A) Two Story SFR - 1997 UBC	2000
New	Approved Basic #99-112260 BP	Plan: 3405 Elev. C Two Story SFR - 19	2000
New	Approved Basic #00-101970 BP	Plan: #2990 (Elev. B) Two Story SFR - 1997 UBC	2000
New	Two Story SFR - 1997 UBC	Plan: 1840 Elev. C	2000
New	Approved Basic #99-112258 BP	Plan: 3405 Elev. A Two Story SFR - 19	2000
New	Approved Basic #00-101974 BP	Plan: #2446 (Elev. C) Two Story SFR - 1997 UBC	2000
New	Approved Basic #00-101971 BP	Plan: #2990 (Elev. C) Two Story SFR - 1997 UBC	2000
New	Approved Basic #00-101972 BP	Plan: #2446 (Elev. A) Two Story SFR - 1997 UBC	2000
New	Approved Basic #00-101968 BP	Plan: #2575 (Elev. C) Two Story SFR - 1997 UBC	2000
New	Approved Basic #00-101970 BP	Plan: #2990 (Elev. B) Two Story SFR - 1997 UBC	2000
New	Approved Basic #98-109883BP Two Story SFR - 1997 UBC	Plan: #244	2000
New	Approved Basic #00-101971 BP	Plan: #2990 (Elev. C) Two Story SFR - 1997 UBC	2000
New	Approved Basic #99-112258 BP	Plan: 3405 Elev. A Two Story SFR - 19	2000
New	Approved Basic #98-110372BP Two Story SFR - 1997 UBC	Plan: #2575 Elv	2000
New	Approved Basic #98-109885BP	OPTION: Approved TJI Two Story SFR - 19	2000
New	Approved Basic #98-109883BP Two Story SFR - 1997 UBC	Plan: #244	2000
New	Approved Basic #98-110372BP Two Story SFR - 1997 UBC	Plan: #2575 Elv	2000
New	Approved Basic #98-110372BP Two Story SFR - 1997 UBC	Plan: #2575 Elv	2000
New	Approved Basic #98-109885BP	OPTION: Approved TJI Two Story SFR - 19	2000
New	Approved Basic #98-109883BP Two Story SFR - 1997 UBC	Plan: #244	2000
New	Approved Basic #98-110372BP Two Story SFR - 1997 UBC	Plan: #2575 Elv	2000
New	Approved Basic #00-101972 BP	Plan: #2446 (Elev. A) Two Story SFR - 1997 UBC	2000

Accessory Dwelling Units

Index # - File Name: 1.0022 - Single Family Dwellings Data\_Snohomish County.pdf

New	Approved Basic #98-110372BP	Two Story SFR - 1997 UBC	Plan: #2575 Elv	2000
New	Approved Basic #99-110098 BP	Two Story SFR - 1997 UBC	Plan: #21	2000
New	Approved Basic #00-101971 BP	Plan: #2990 (Elev. C) Two Story SFR - 1997 UBC		2000
New	Two-story SFR w/attached garage - 1997 UBC			2000
New	Approved Basic #99-109955 BP	Plan: 2148 Elev. B Two Story SFR - 1997		2000
New	Approved Basic #00-101967 BP	Plan: #2575 (Elev. B) Two Story SFR - 1997 UBC		2000
New	Two Story SFR - 1997 UBC	Plan: 1906 Elev. B		2000
New	Two Story SFR - 1997 UBC	Plan: 1906 Elev. C		2000
New	Approved Basic #98-110372BP	Two Story SFR - 1997 UBC	Plan: #2575 Elv	2000
New	Approved Basic #98-109883BP	Two Story SFR - 1997 UBC	Plan: #244	2000
New	Approved Basic #98-110372BP	Two Story SFR - 1997 UBC	Plan: #2575 Elv	2000
New	Approved Basic #98-109885BP	OPTION: Approved TJI Two Story SFR - 19		2000
New	Approved Basic #98-109885BP	OPTION: Approved TJI Two Story SFR - 19		2000
New	2-Story SFR w/attached garage.			2000
New	Approved Basic #99-115750 BP	Two Story SFR - 1997 UBC		2000
New	2 Story w/ 2 Car			2000
New	2 Story w/ 2 Car			2000
New	2047 sf rambler w/1152 sf garage, 36 sf covered deck/porch and 264 sf open deck			2000
New	Approved Basic # 00-109999BP	Plan: 2063 A-1 Rambler Style SFR - 1997 UBC		2000
New	2-Story SFR w/Covered porches.			2000
New	27x66, 2000 Golden West			2000
New	Approved Basic #99-101212BP	Plan: 5022/5322 w/bonus rm Two Story SFR - 1997 UBC		2000
New	Approved Basic #00-104044 BP	Plan: 4005 B Two Story SFR - 1997 UBC		2000
New	Approved Basic #99-101211BP	Plan: 5023/5123 w/bonus rm Two Story SFR - 1997 UBC		2000
New	Approved Basic #99-114271 BP	Plan: 4202 B/C Two Story SFR - 1997 UBC		2000
New	Approved Basic #99-103347BP	Plan: 4001 Two Story SFR - 199		2000
New	Approved Basic #00-103115 BP	Plan: 4105 A Two Story SFR - 1997 UBC		2000
New	Approved Basic #99-114270 BP	Plan: 4202 A Two Story SFR - 19		2000
New	Approved Basic #99-101211BP	Two Story SFR - 1997 UBC	Plan: 5023/5123 w	2000
New	Approved Basic #99-103348BP	Plan: 5218 Elev.C Two Story SFR - 1997 UBC		2000
New	Approved Basic #99-101211BP	Plan: 5023/5123 w/bonus rm Two Story SFR - 1997 UBC		2000
New	Approved Basic #99-103574BP	Plan: 4002 Two Story SFR - 1997 UB		2000
New	Approved Basic #99-114152 BP	Plan: 5522 w/bonus Two Story SFR - 1		2000
New	Approved Basic #99-103574BP	Plan: 4002 Two Story SFR - 1997 UB		2000
New	Approved Basic #99-103349BP	Plan: 5318 Elev. C Two Story SFR - 1997 UBC		2000
New	Approved Basic #99-103832BP	Plan: 4003 Two Story SFR - 199		2000
New	Approved Basic #99-114153 BP	Plan: 5422 w/bonus Two Story SFR - 1997 UBC		2000
New	Approved Basic #00-104042 BP	Plan: 4105 B Two Story SFR - 1997 UBC		2000
New	Approved Basic #99-103348BP	Plan: 5218 Elev. A,B & C Two Story SFR - 1997 UBC		2000
New	Approved Basic #99-114271 BP	Plan: 4202 B/C Two Story SFR - 1997 UBC		2000
New	Approved Basic #99-101211BP	Plan: 5023/5123 w/bonus rm Two Story SFR - 1997 UBC		2000
New	Approved Basic #99-114152 BP	Plan: 5522 w/bonus Two Story SFR - 1997 UBC		2000
New	Approved Basic #99-101211BP	Plan: 5023/5123 w/bonus rm Two Story SFR - 1997 UBC		2000
New	Approved Basic #99-114154 BP	Plan: 5122 w/o bonus Two Story SFR		2000
New	Approved Basic #99-101211BP	Two Story SFR - 1997 UBC	Plan: 5023/5123 w	2000
New	Approved Basic #99-103349BP	Plan: 5318 Two Story SFR - 199		2000
New	Approved Basic #99-101214BP	Two Story SFR - 1997 UBC	Plan: 5223/5323 w/k	2000

Accessory Dwelling Units

Index # - File Name: 1.0022 - Single Family Dwellings Data\_Snohomish County.pdf

New	Approved Basic #99-103349BP	Plan: 5318	Two Story SFR - 1997	2000
New	Approved Basic #99-103342BP	Plan: 5222	Two Story SFR - 1997 UBC	2000
New	Mid-entry SFR w/attached 2-car garage.....		1997 UBC	2000
New	Mid-entry SFR w/attached 2-car garage.....		1997 UBC	2000
New	Two-story SFR w/attached garage. 2/8/01 Dan Smith said Rye McDuffy, Surveyor, confirmed th			2000
New	762 sf cabin w/210 sf loft and 246 sf covered porch			2000
New	Approved Basic No. 00-106793 BP	Bldrs Plan No. 465B	Two Story - 1997 UBC	2000
New	Approved Basic #00-103982 BP	Plan: #465 A	Two Story SFR - 1997 UBC	2000
New	Approved Basic No. 00-106793 BP	Bldrs Plan No. 465B	Two Story SFR.....	1997 UBC 2000
New	Approved Basic #00-103982 BP	Plan: #465 A	Two Story SFR - 1997 UBC	2000
New	Approved Basic #00-103981 BP	SFR w/finished lower floor - 1997 UBC		Plan # 2000
New	Approved Basic #00-103981 BP	SFR w/finished lower floor - 1997 UBC		Plan # 2000
New	Approved Basic #00-104881 BP	Plan #493 B - end	Two Story SFR - 1997 UBC	2000
New	Approved Basic #00-104881 BP	Plan #493 B - end	Two Story SFR - 1997 UBC	2000
New	Approved Basic #00-103981 BP	SFR w/finished lower floor - 1997 UBC		Plan # 2000
New	Approved Basic #00-103981 BP	SFR w/finished lower floor - 1997 UBC		Plan # 2000
New	Approved Basic #99-101211BP	Plan: 5023/5123 w/bonus rm	Two Story SFR - 1997 UBC	2000
New	Approved Basic #99-103832BP	Plan: 4003	Two Story SFR - 1997	2000
New	Approved Basic #99-103342BP	Plan: 5222	Two Story SFR - 1997	2000
New	Approved Basic #99-103347BP	Plan: 4001	Two Story SFR - 1997	2000
New	Approved Basic #99-103342BP	Plan: 5222	Two Story SFR - 1997	2000
New	Approved Basic #99-103574BP	Plan: 4002	Two Story SFR - 1997 UB	2000
New	Two Story SFR with Attached Garage			2000
New	1987 Golden West Bradbury 27 x 48	MH being moved from lot line between lots 9 & 10 to lot 9		2000
New	1989 Golden West 28 x 60			2000
New	2000 Marlette Platinum XL 64 28 x 68			2000
New	2-story SFR w/attached 2-car garage....		1997 UBC	2000
New	Two Story Duplex w/finished lower floor - 1997 UBC			2000
New	Two Story Duplex w/finished lower floor - 1997 UBC			2000
New	Two Story SFR - 1997 UBC	Plan: 1743 A-2 F/0		2000
New	Approved Basic #00-103329 BP	Plan #294 B2F-0	Two Story SFR - 1997 UBC	2000
New	Approved Basic #00-103631 BP	Plan: 1745	Two Story SFR - 1997 UBC	2000
New	Two Story SFR w/finished basement - 1997 UBC			2000
New	2 Story SFR over basement w/attached garage.		1997-UBC	2000
New	Approved Basic #00-105733 BP	Plan: 2008	Two Story SFR - 1997 UBC	2000
New	Approved Basic #00-103329 BP	Plan #294 B2F-0	Two Story SFR - 1997 UBC	2000
New	Approved Basic #99-114285 BP	Plan # Aspen 2	Two Story SFR - 1997 UBC	2000
New	Approved Basic #00-105733 BP	Plan: 2008	Two Story SFR - 1997 UBC	2000
New	Two Story SFR - 1997 UBC	Plan: 1745		2000
New	Two Story SFR w/finished basement - 1997 UBC			2000
New	2-Story SFR over basement w/attached garage.		1997-UBC	2000
New	Two Story SFR w/finished basement - 1997 UBC			2000
New	Approved Basic #00-103303 BP	Two Story SFR - 1997 UBC		Plan #4: 2000
New	Approved Basic #99-101116BP	SFR w/finished lower floor - 1997 UBC		Plan # 2000
New	Approved Basic #00-106429 BP	Plan #496 Elev. A - crawl space/ w/o bump out	Two Story SFR	2000
New	Approved Basic #00-101735 BP	Plan: 394 A (post & beam & continuous footing)	Tri-level SFF	2000
New	Approved Basic #00-102570 BP	Plan: 394 B (post & beam & continuous footing)	Tri-level SFF	2000

Accessory Dwelling Units

Index # - File Name: 1.0022 - Single Family Dwellings Data\_Snohomish County.pdf

New	Approved Basic #00-107079 BP	Bldrs Plan No. 595A	Two Story w/finished basement	2000
New	Approved Basic #98-109547BP	Two Story SFR - 1997 UBC	Plan #490 (E	2000
New	Two Story SFR w/finished basement - 1997 UBC	Plan: 595		2000
New	Approved Basic #00-101733 BP	Plan #496 Elev. A - crawl space	Two Story SFR - 1997 U	2000
New	Approved Basic #00-106428 BP	Plan #496 Elev. B - crawl space/w/o bump out	Two Story SFR ·	2000
New	Approved Basic #00-101735 BP	Plan: 394 A (post & beam & continuous footing)	Tri-level SFF	2000
New	Approved Basic #00-108422 BP	Plan: 394(3)A	Two Story SFR w/finished l	2000
New	Approved Basic #99-101116BP	SFR w/finished lower floor - 1997 UBC	Plan #	2000
New	Approved Basic #00-101735 BP	Plan: 394 A (post & beam & continuous footing)	Tri-level SFF	2000
New	Approved Basic #00-102570 BP	Plan: 394 B (post & beam & continuous footing)	Tri-level SFF	2000
New	Approved Basic #00-101735 BP	Plan: 394 A (post & beam & continuous footing)	Tri-level SFF	2000
New	Approved Basic #00-101735 BP	Plan: 394 A (post & beam & continuous footing)	Tri-level SFF	2000
New	Approved Basic #00-101732 BP	Plan: 486 w/bonus	Two Story SFR - 1997 UBC	2000
New	Approved Basic #00-101732 BP	Plan: 486 w/bonus	Two Story SFR - 1997 UBC	2000
New	Approved Basic #00-102570 BP	Plan: 394 B (post & beam & continuous footing)	Tri-level SFF	2000
New	Approved Basic #00-108422 BP	Plan: 394(3)A	Two Story SFR w/finished l	2000
New	Two Story Duplex w/finished lower floor - 1997 UBC			2000
New	Two Story Duplex w/finished lower floor - 1997 UBC			2000
New	Two Story Duplex w/finished lower floor - 1997 UBC			2000
New	Approved Basic #98-116267BP	Plan: North Carolina w/den	Two Story SFR - 1997	2000
New	1860 s.f. rambler w/2 car garage			2000
New	2 story SFR with attached garage and covered porch			2000
New	2 story sfr w/2 car garage			2000
New	Approved Basic #00-107014 BP	Bldrs Plan: 2230E (revised)	Two Story SFR.....1997 U	2000
New	Approved Basic #00-108714 BP	Bldrs Plan: 2188 Short/Front 2 Car	Two Story style S	2000
New	Two-story SFR w/daylight basement & attached garage -	Plan 2258		2000
New	1997-UBC 1997-WSEC			2000
New	Approved Basic #99-100561BP	Two Story SFR - 1997 UBC	Plan #48	2000
New	Approved Basic #00-101732 BP	Plan: 486 w/bonus	Two Story SFR - 1997 UBC	2000
New	Approved Basic #00-103303 BP	Two Story SFR - 1997 UBC	Plan #4i	2000
New	Approved Basic #00-103329 BP	Plan #294 B2F-0	Two Story SFR - 1997 UBC	2000
New	2-Story SFR w/attached garage.	1997-UBC		2000
New	Approved Basic #00-103329 BP	Plan #294 B2F-0	Two Story SFR - 1997 UBC	2000
New	Approved Basic #00-103329 BP	Plan #294 B2F-0	Two Story SFR - 1997 UBC	2000
New	Two Story SFR - 1997 UBC	Plan: 2008		2000
New	Approved Basic #00-103631 BP	Plan: 1745	Two Story SFR - 1997 UBC	2000
New	Approved Basic #00-103703 BP	Plan #493 A - front	Two Story SFR - 1997 UBC	2000
New	Approved Basic #00-101732 BP	Plan: 486 w/bonus	Two Story SFR - 1997 UBC	2000
New	Approved Basic #00-101735 BP	Plan: 394 A (post & beam & continuous footing)	Tri-level SFF	2000
New	Approved Basic #00-106428 BP	Plan #496 Elev. B - crawl space/w/o bump out	Two Story SFR ·	2000
New	Approved Basic #00-102570 BP	Plan: 394 B (post & beam & continuous footing)	Tri-level SFF	2000
New	2-Story SFR w/attached garage.	1997-UBC		2000
New	Approved Basic #98-110058BP	Plan #1214	Split Entry Style SFR w/bas	2000
New	Approved Basic #00-103963 BP	Plan #1803	Two Story SFR - 1997 UBC	2000
New	2-Story SFR w/attached garage.			2000
New	Approved Basic #00-103963 BP	Plan #1803	Two Story SFR - 1997 UBC	2000
New	Approved Basic #00-103963 BP	Plan #1803	Two Story SFR - 1997 UBC	2000

Accessory Dwelling Units

Index # - File Name: 1.0022 - Single Family Dwellings Data\_Snohomish County.pdf

New	Approved Basic #00-103961 BP	Plan: 1715 Two Story SFR - 1997 UBC	2000
New	Approved Basic #00-103961 BP	Plan: 1715 Two Story SFR - 1997 UBC	2000
New	Approved Basic #00-103961 BP	Plan: 1715 Two Story SFR - 1997 UBC	2000
New	Approved Basic #00-103960 BP	Plan: 1876 Two Story SFR - 1997 UBC	2000
New	2-story SFR w/attached 2-car garage...1997 UBC	Bldrs Plan No. 1805	2000
New	Approved Basic #00-103960 BP	Plan: 1876 Two Story SFR - 1997 UBC	2000
New	Approved Basic #00-103959 BP	Plan: 1553 Rambler Style SFR - 1997 U	2000
New	2-story SFR w/attached 2-car garage...1997 UBC	Bldrs Plan No. 1715	2000
New	2-story SFR w/attached 2-car garage.....1997 UBC	Bldrs Plan No. 1803	2000
New	Rambler w/attached 2-car garage...1997 UBC	Bldrs Plan No. 1553	2000
New	Approved Basic #00-103961 BP	Plan: 1715 Two Story SFR - 1997 UBC	2000
New	2-story SFR w/attached 2-car garage...1997 UBC	Bldrs Plan No. 1876	2000
New	Approved Basic 99-101299BP	Plan: #10 Mid-Entry With 2 Car - 1997 U	2000
New	2-story SFR.....1997 UBC		2000
New	2-story SFR w/attached 2-car garage.....1997 UBC		2000
New	2 Story w/2 Car		2000
New	One-story SFR w/semi-finished basement & attached garage		2000
New	1999 Oakwood 14 x 66		2000
New	Approved Basic No. 00-104279 BP SFR w/finished lower floor - 1997 UBC	Bldrs Pla	2000
New	27x52 2000 Skyline		2000
New	2022 sf 2-story w/390 sf garage, 65 sf covered deck/porch and 100 sf open deck		2000
New	1970 sf 2-story w/432 sf garage, 38 sf covered deck/porch and 100 sf open deck		2000
New	Two-story SFR w/attached garage	Plan 1969	2000
New	Approved Basic #00-103901-BP	Plan 1784 Two Story SFR, 1997-UBC	2000
New	Approved Basic #00-103902-BP	Plan #2043 Two Story SFR, 1997-UBC	2000
New	Two-story SFR w/attached garage	Plan 1852	2000
New	Approved Basic #00-103904 BP	Plan: 1852 (hip & crawl) Two Story SFR, 1997-UE	2000
New	Approved Basic #00-103898-BP	Plan 1969 Two Story SFR, 1997-UBC	2000
New	Approved Basic #00-103904-BP	Plan 1852 Two Story SFR, 1997-UBC	2000
New	Approved Basic #00-103902-BP	Plan #2043 Two Story SFR, 1997-UBC	2000
New	Approved Basic #00-103898-BP	Plan 1969 Two Story SFR, 1997-UBC	2000
New	Approved Basic #00-103902-BP	Plan 2043 Two Story SFR, 1997-UBC	2000
New	Approved Basic #00-103901-BP	Plan 1784 Two Story SFR, 1997-UBC	2000
New	Approved Basic #00-103901-BP	Plan 1784 Two Story SFR, 1997-UBC	2000
New	Approved Basic No. 00-104409 BP Rambler style SFR...1997 UBC	Bldrs Pla	2000
New	Approved Basic #00-101994 BP	Plan: 2330 Two Story SFR - 1997 UBC	2000
New	Approved Basic No. 00-104409 BP Rambler style SFR...1997 UBC	Bldrs Pla	2000
New	40 x 56 - 2000 - Marlette		2000
New	Approved Basic No. 00-104409 BP Rambler style SFR...1997 UBC	Bldrs Pla	2000
New	Approved Basic #99-113971 BP	Plan: 1315 Split Level SFR - 1997 UBC	2000
New	Approved Basic #99-113971 BP	Plan: 1315 Split Level SFR - 1997 UBC	2000
New	28x48, 1999 Oakwood		2000
New	Approved Basic #98-116414BP	Plan: 2483 Two Story SFR - 1997 UBC	2000
New	2528 sf 2-story w/623 sf garage, and 59 sf covered deck/porch		2000
New	Two-story SFR w/attached garage		2000
New	Two Story w/attached 1-car garage.....1997 UBC		2000
New	Approved Basic #98-110504BP	Plan #2195 Split Level SFR - 1997 UBC	2000



Accessory Dwelling Units

Index # - File Name: 1.0022 - Single Family Dwellings Data\_Snohomish County.pdf

New	Approved Basic #99-115493 BP	Plan #1927	Two Story SFR - 1997 UB	2000
New	Approved Basic #98-110504BP	Plan #2195	Split Level SFR - 1997 UBC	2000
New	Approved Basic #00-108352 BP	Plan: 1405 w/basement	SFR w/basement - 1997	2000
New	Approved Basic #00-103392 BP	Plan: 1715	Two-story SFR w/semi finished ba	2000
New	Approved Basic #00-105975 BP	Plan: 1632 w/basement	Two Story SFR w/semi-fi	2000
New	Approved Basic #00-103392 BP	Plan: 1715	Two-story SFR w/semi finished baseme	2000
New	Approved Basic #00-105975 BP	Plan: 1632 w/basement	Two Story SFR w/semi-fi	2000
New	Approved Basic #99-103276BP	Plan: #2461	Two Story SFR - 1997 UBC	2000
New	Approved Basic #00-105975 BP	Plan: 1632 w/basement	Two Story SFR w/semi-fi	2000
New	Split Level SFR w/semi-finished basement - 1997 UBC	Plan: 1715		2000
New	2-story SFR w/semi-finished basement & attached 2/car garage.....1997 UBC	Plan No. 163		2000
New	28 X 40 Guerdon 1992			2000
New	Approved Basic #00-100585 BP	Plan: 662 B	Two Story SFR - 1997 UBC	2000
New	Approved Basic #00-102182 BP	Plan: 923 A/B	Two Story SFR - 1997 UBC	2000
New	Approved Basic #98-110285BP	Two Story SFR - 1997 UBC	Plan: 93	2000
New	Approved Basic #00-102592 BP	Plan: 1755 C	Two Story SFR - 1997 UBC	2000
New	Approved Basic #00-106376 BP	Plan: 936 G	Two Story SFR - 1997 UBC	2000
New	Approved Basic #00-100582 BP	Plan: 939 B	Two Story SFR - 1997 UBC	2000
New	Approved Basic #98-109946BP	Two Story SFR - 1997 UBC	Plan: #9	2000
New	Approved Basic #98-109939BP	Two Story SFR - 1997 UBC	Plan: #9	2000
New	Approved Basic #98-110285BP	Two Story SFR - 1997 UBC	Plan: 93	2000
New	Approved Basic #00-105848 BP	Plan: 936 A D	Two Story SFR - 1997 UBC	2000
New	Approved Basic #98-109939BP	Two Story SFR - 1997 UBC	Plan: #9	2000
New	Approved Basic #00-106376 BP	Plan: 936 G	Two Story SFR - 1997 UBC	2000
New	Approved Basic #98-110285BP	Two Story SFR - 1997 UBC	Plan: 93	2000
New	Approved Basic #00-105848 BP	Plan: 936 A D	Two Story SFR - 1997 UBC	2000
New	Approved Basic #98-109946BP	Two Story SFR - 1997 UBC	Plan: #9	2000
New	Approved Basic #00-102453 BP	Plan: 936 G	Two Story SFR - 1997 UBC	2000
New	Approved Basic #98-109939BP	Two Story SFR - 1997 UBC	Plan: #9	2000
New	Approved Basic #98-110285BP	Two Story SFR - 1997 UBC	Plan: 93	2000
New	Two Story SFR - 1997 UBC	Plan: 936		2000
New	Two Story SFR - 1997 UBC	Plan: 662 M		2000
New	Two Story SFR - 1997 UBC	Plan # 937 D		2000
New	Approved Basic #00-102592 BP	Plan: 1755 C	Two Story SFR - 1997 UBC	2000
New	Approved Basic #00-100585 BP	Plan: 662 B	Two Story SFR - 1997 UBC	2000
New	Approved Basic #00-102592 BP	Plan: 1755 C	Two Story SFR - 1997 UBC	2000
New	Approved Basic #00-100582 BP	Plan: 939 B	Two Story SFR - 1997 UBC	2000
New	Approved Basic #98-109939BP	Two Story SFR - 1997 UBC	Plan: #9	2000
New	Approved Basic #98-110285BP	Two Story SFR - 1997 UBC	Plan: 93	2000
New	Two Story SFR - 1997 UBC	Plan: 1755 M		2000
New	Approved Basic #98-110285BP	Two Story SFR - 1997 UBC	Plan: 93	2000
New	Approved Basic #00-102453 BP	Plan: 936 G	Two Story SFR - 1997 UBC	2000
New	Approved Basic #00-102182 BP	Plan: 923 A/B	Two Story SFR - 1997 UBC	2000
New	Approved Basic #00-105795 BP	Plan: 937 D	Two Story SFR - 1997 UBC	2000
New	Approved Basic #00-102592 BP	Plan: 1755 C	Two Story SFR - 1997 UBC	2000
New	Approved Basic #00-100585 BP	Plan: 662 B	Two Story SFR - 1997 UBC	2000
New	Approved Basic #00-102182 BP	Plan: 923 A/B	Two Story SFR - 1997 UBC	2000

Accessory Dwelling Units

Index # - File Name: 1.0022 - Single Family Dwellings Data\_Snohomish County.pdf

New	Approved Basic #00-100582 BP	Plan: 939 B Two Story SFR - 1997 UBC	2000
New	Two Story SFR -1997 UBC	Plan: 1755 C	2000
New	Approved Basic #00-102182 BP	Plan: 923 A/B Two Story SFR - 1997 UBC	2000
New	Approved Basic #98-109939BP	Two Story SFR - 1997 UBC	Plan: #9 2000
New	Approved Basic #00-102453 BP	Plan: 936 G Two Story SFR - 1997 UBC	2000
New	Approved Basic #98-110285BP	Two Story SFR - 1997 UBC	Plan: 93 2000
New	Approved Basic #00-102592 BP	Plan: 1755 C Two Story SFR - 1997 UBC	2000
New	Approved Basic #00-102182 BP	Plan: 923 A/B Two Story SFR - 1997 UBC	2000
New	Approved Basic #00-100582 BP	Plan: 939 B Two Story SFR - 1997 UBC	2000
New	Approved Basic #98-109939BP	Two Story SFR - 1997 UBC	Plan: #9 2000
New	Approved Basic #00-105848 BP	Plan: 936 A D Two Story SFR - 1997 UBC	2000
New	Approved Basic #98-109939BP	Two Story SFR - 1997 UBC	Plan: #9 2000
New	Approved Basic #00-106376 BP	Plan: 936 G Two Story SFR - 1997 UBC	2000
New	Approved Basic #00-105795 BP	Plan: 937 D Two Story SFR - 1997 UBC	2000
New	Approved Basic #98-110285BP	Two Story SFR - 1997 UBC	Plan: 93 2000
New	Approved Basic #98-109946BP	Two Story SFR - 1997 UBC	Plan: #9 2000
New	Approved Basic #00-102182 BP	Plan: 923 A/B Two Story SFR - 1997 UBC	2000
New	Approved Basic #00-100578 BP	Two Story SFR - 1997 UBC	Plan # 9 2000
New	Approved Basic #00-102592 BP	Plan: 1755 C Two Story SFR - 1997 UBC	2000
New	Approved Basic #00-100585 BP	Plan: 662 B Two Story SFR - 1997 UBC	2000
New	Rambler w/attached one car garage.		2000
New	Approved Basic #00-102261 BP	Plan: 1221 B Two Story SFR - 1997 UBC	2000
New	Approved Basic #00-102261 BP	Plan: 1221 B Two Story SFR - 1997 UBC	2000
New	Approved Basic #00-101205 BP	Plan: 1008 Rambler Style SFR - 1997 UBC	2000
New	Approved Basic #00-101205 BP	Plan: 1008 Rambler Style SFR - 1997 UBC	2000
New	2 story SFR with attached garage	Plan: 969	2000
New	Approved Basic #00-101205 BP	Plan: 1008 Rambler Style SFR - 1997 UBC	2000
New	Approved Basic #00-101205 BP	Plan: 1008 Rambler Style SFR - 1997 UBC	2000
New	One-story SFR w/attached garage	Builders Plan 1008	2000
New	Approved Basic #00-101474 BP	Plan: 969 Two Story SFR - 1997 UBC	2000
New	Approved Basic #00-101627 BP	Plan: 1221 A Two Story SFR - 1997 UBC	2000
New	Approved Basic #00-101474 BP	Plan: 969 Two Story SFR - 1997 UBC	2000
New	Approved Basic #00-101627 BP	Plan: 1221 A Two Story SFR - 1997 UBC	2000
New	Approved Basic #00-101474 BP	Plan: 969 Two Story SFR - 1997 UBC	2000
New	Approved Basic #00-101474 BP	Plan: 969 Two Story SFR - 1997 UBC	2000
New	Approved Basic #00-101474 BP	Plan: 969 Two Story SFR - 1997 UBC	2000
New	Approved Basic #00-101627 BP	Plan: 1221 A Two Story SFR - 1997 UBC	2000
New	Approved Basic #00-101627 BP	Plan: 1221 A Two Story SFR - 1997 UBC	2000
New	Approved Basic #00-101205 BP	Plan: 1008 Rambler Style SFR - 1997 UBC	2000
New	Approved Basic #00-101474 BP	Plan: 969 Two Story SFR - 1997 UBC	2000
New	Two Story SFR - 1997 UBC	Plan: 1221	2000
New	Approved Basic #00-101474 BP	Plan: 969 Two Story SFR - 1997 UBC	2000
New	Approved Basic #00-101358 BP	Split w/ 2 car garage - 1997 UBC	Plan # 2000
New	2 story SFR with deck		2000
New	2 Story w/ 2 Car		2000
New	Approved Basic #99-115061 BP	Plan: B 107 Two Story SFR - 1997 UBC	2000
New	Approved Basic #98-109468BP	Plan # B-406 c/d Two Story SFR - 1997 UBC	2000

Accessory Dwelling Units

Index # - File Name: 1.0022 - Single Family Dwellings Data\_Snohomish County.pdf

New	Approved Basic #98-109460BP	Plan # A-311 a/b	Two Story SFR - 1997 UB	2000
New	Approved Basic #00-100774 BP	Two Story SFR - 1997 UBC	Plan: 315 A/B	2000
New	2-story SFR w/attached 2-car garage....1997 UBC			2000
New	Two Story SFR - 1997 UBC	Plan: G 519-A		2000
New	Detached garage w/1104 sq ft of living space on the second floor.....1997 UBC			2000
New	Approved Basic #98-116988BP	Option Approved: Main floor plan layout	2 story sfr (1st floor	2000
New	Approved Basic #00-100774 BP	Two Story SFR - 1997 UBC	Plan: 315 A/B	2000
New	Approved Basic #99-115061 BP	Plan: B 107 A	Two Story SFR - :	2000
New	Two Story SFR with Attached Garage			2000
New	Approved Basic #98-109468BP	Plan # B-406 c/d	Two Story SFR - 1997 U	2000
New	Two Story SFR - 1997 UBC	Plan: 2590 C		2000
New	Approved Basic #00-104277 BP	Plan #2294 A	Two Story SFR - 1997 UBC	2000
New	2 Story SFR w/3 Car			2000
New	2320 sf 2-story w/460 sf garage w/27 sf covered porch			2000
New	Approved Basic #00-103329 BP	Plan #2294 B	Two Story SFR - 1997 UBC	2000
New	2-Story SFR w/attached garage.			2000
New	Two Story SFR - 1997 UBC	Plan: 2590		2000
New	Approved Basic #00-104277 BP	Plan #2294 A	Two Story SFR - 1997 UBC	2000
New	Approved Basic #00-102579-BP	Plan=2220S/2	Mid-Entry Style SFR w/finished l	2000
New	Approved Basic #00-103329 BP	Plan #2294 B	Two Story SFR - 1997 UBC	2000
New	Approved Basic #00-102464 BP	Plan: #2230 E	Two Story SFR - 1997 UBC	2000
New	Approved Basic #00-106428 BP	Plan #496 Elev. B - crawl space/w/o bump out	Two Story SFR ·	2000
New	Approved Basic #00-102570 BP	Plan: 394 B (post & beam & continuous footing)	Tri-level SFF	2000
New	Approved Basic #00-101733 BP	Plan #496 A - crawl space	Two Story SFR - 1997 UBC	2000
New	Approved Basic #00-101732 BP	Plan: 486 w/bonus	Two Story SFR - 1997 UBC	2000
New	Approved Basic #00-101732 BP	Plan: 486 w/bonus	Two Story SFR - 1997 UBC	2000
New	Approved Basic #98-116359BP	Plan: 394	SFR w/finished lower fl	2000
New	Approved Basic #00-101735 BP	Plan: 394 A (post & beam & continuous footing)	Tri-level SFF	2000
New	Approved Basic #00-108631 BP	Plan: 598 2A	Two Story SFR - 1997 UBC	2000
New	Approved Basic #00-106429 BP	Plan #496 Elev. A - crawl space/ w/o bump out	Two Story SFR	2000
New	Approved Basic #99-100564BP	Two Story SFR - 1997 UBC	Plan #48	2000
New	Approved Basic #98-116359BP	Plan: 394	SFR w/finished lower fl	2000
New	Two Story SFR - 1997 UBC	Plan: 2590 C		2000
New	Approved Basic #00-106348 BP	Plan No. M2102 A2F-0	Two Story SFR.....1997 UBC	2000
New	Approved Basic #00-103329 BP	Plan #2294 B	Two Story SFR - 1997 UBC	2000
New	Two Story SFR - 1997 UBC	Plan: 2590		2000
New	Approved Basic #00-101735 BP	Plan: 394 A (post & beam & continuous footing)	Tri-level SFF	2000
New	Approved Basic #00-102570 BP	Plan: 394 B (post & beam & continuous footing)	Tri-level SF	2000
New	Approved Basic #00-106429 BP	Plan #496 Elev. A - crawl space/ w/o bump out	Two Story SFR	2000
New	Approved Basic #00-102570 BP	Plan: 394 B (post & beam & continuous footing)	Tri-level SFF	2000
New	Approved Basic #00-101735 BP	Plan: 394 A (post & beam & continuous footing)	Tri-level SFF	2000
New	Approved Basic #00-106428 BP	Plan #496 Elev. B - crawl space/w/o bump out	Two Story SFR ·	2000
New	Approved Basic #99-100561BP	Two Story SFR - 1997 UBC	Plan #48	2000
New	Approved Basic #00-103303 BP	Two Story SFR - 1997 UBC	Plan #4:	2000
New	Approved Basic #00-101732 BP	Plan: 486 w/bonus	Two Story SFR - 1997 UBC	2000
New	Approved Basic #00-103703 BP	Plan #493 A - front	Two Story SFR - 1997 UBC	2000
New	Approved Basic #00-101732 BP	Plan: 486 w/bonus	Two Story SFR - 1997 UBC	2000

Accessory Dwelling Units

Index # - File Name: 1.0022 - Single Family Dwellings Data\_Snohomish County.pdf

New	Approved Basic #00-103303 BP	Two Story SFR - 1997 UBC	Plan #4:	2000
New	Approved Basic #00-103900 BP		Plan #G 521A SM Two Story SFR - 1997 UBC	2000
New	Approved Basic #00-103900 BP		Plan #G 521A SM Two Story SFR - 1997 UBC	2000
New	Two Story SFR - 1997 UBC		Plan: G 520-A	2000
New	Approved Basic #00-101415-BP		Bldrs Plan 1434 Rambler Style SFR - 1997 U	2000
New	Approved Basic #00-101415-BP		Bldrs Plan 1434 Rambler Style SFR - 1997 U	2000
New	Rambler w/attached 2-car garage.....1997 UBC			2000
New	Rambler w/attached 2-car garage....1997 UBC			2000
New	Approved Basic #98-109460BP		Plan # A-311 a/b Two Story SFR - 1997 UB	2000
New	Two-story SFR w/attached garage			2000
New	Approved Basic 99-115181BP		Plan: 1199 Rambler Style SFR - 1997 U	2000
New	Approved Basic 99-115184 BP		Plan: 1399 Rambler Style SFR - 1997 U	2000
New	Approved Basic 99-115181BP		Plan: 1199 Rambler Style SFR - 1997 U	2000
New	Approved Basic 99-115184 BP		Plan: 1399 Rambler Style SFR - 1997 U	2000
New	Approved Basic 99-115184 BP		Plan: 1399 Rambler Style SFR - 1997 U	2000
New	Approved Basic 99-115184 BP		Plan: 1399 Rambler Style SFR - 1997 U	2000
New	Approved Basic #00-103621 BP		Plan: 1199 (slab) Rambler Style SFR - 1997 UB	2000
New	Approved Basic #00-103622 BP		Plan: 1399 (slab) Rambler Style SFR - 1997 UBC	2000
New	Approved Basic 99-115184 BP		Plan: 1399 Rambler Style SFR - 1997 UBC	2000
New	Approved Basic 99-115181BP		Plan: 1199 Rambler Style SFR - 1997 U	2000
New	Approved Basic 99-115184 BP		Plan: 1399 Rambler Style SFR - 1997 UBC	2000
New	Approved Basic 99-115184 BP		Plan: 1399 Rambler Style SFR - 1997 UBC	2000
New	Approved Basic 99-115184 BP		Plan: 1399 Rambler Style SFR - 1997 UBC	2000
New	Approved Basic 99-115184 BP		Plan: 1399 Rambler Style SFR - 1997 UBC	2000
New	Approved Basic 99-115184 BP		Plan: 1399 Rambler Style SFR - 1997 UBC	2000
New	Approved Basic 99-115184 BP		Plan: 1399 Rambler Style SFR - 1997 UBC	2000
New	Approved Basic 99-115184 BP		Plan: 1399 Rambler Style SFR - 1997 UBC	2000
New	Approved Basic 99-115184 BP		Plan: 1399 Rambler Style SFR - 1997 UBC	2000
New	Approved Basic 99-115184 BP		Plan: 1399 Rambler Style SFR - 1997 UBC	2000
New	Approved Basic 99-115184 BP		Plan: 1399 Rambler Style SFR - 1997 UBC	2000
New	Approved Basic 99-115184 BP		Plan: 1399 Rambler Style SFR - 1997 UBC	2000
New	Approved Basic 99-115184 BP		Plan: 1399 Rambler Style SFR - 1997 UBC	2000
New	Approved Basic 99-115184 BP		Plan: 1399 Rambler Style SFR - 1997 UBC	2000
New	Approved Basic 99-115184 BP		Plan: 1399 Rambler Style SFR - 1997 UBC	2000
New	Approved Basic 99-115184 BP		Plan: 1399 Rambler Style SFR - 1997 UBC	2000
New	Approved Basic 99-115184 BP		Plan: 1399 Rambler Style SFR - 1997 UBC	2000
New	Approved Basic 99-115181BP		Plan: 1199 Rambler Style SFR - 1997 U	2000
New	Approved Basic 99-115184 BP		Plan: 1399 Rambler Style SFR - 1997 UBC	2000
New	Approved Basic 99-115184 BP		Plan: 1399 Rambler Style SFR - 1997 UBC	2000
New	Approved Basic 99-115184 BP		Plan: 1399 Rambler Style SFR - 1997 UBC	2000
New	Approved Basic #00-103621 BP		Plan: 1199 (slab) Rambler Style SFR - 1997 UB	2000
New	Approved Basic #00-103622 BP		Plan: 1399 (slab) Rambler Style SFR - 1997 UBC	2000
New	Approved Basic #00-103622 BP		Plan: 1399 (slab) Rambler Style SFR - 1997 UBC	2000
New	Approved Basic #00-103622 BP		Plan: 1399 (slab) Rambler Style SFR - 1997 UBC	2000
New	Approved Basic #00-103621 BP		Plan: 1199 (slab) Rambler Style SFR - 1997 UB	2000
New	Approved Basic #00-103621 BP		Plan: 1199 (slab) Rambler Style SFR - 1997 UB	2000
New	Approved Basic #00-103622 BP		Plan: 1399 (slab) Rambler Style SFR - 1997 UBC	2000
New	Approved Basic 99-115181 BP		Plan: 1100 Rambler Style SFR - 1997 UBC	2000
New	Approved Basic 99-115184 BP		Plan: 1399 Rambler Style SFR - 1997 U	2000
New	Approved Basic 99-115184 BP		Plan: 1399 Rambler Style SFR - 1997 U	2000

Accessory Dwelling Units

Index # - File Name: 1.0022 - Single Family Dwellings Data\_Snohomish County.pdf

New	Approved Basic 99-115184 BP	Plan: 1399 Rambler Style SFR - 19	2000
New	Approved Basic 99-115181BP	Plan: 1199 Rambler Style SFR - 1997 U	2000
New	Approved Basic #00-103622 BP	Plan: 1399 (slab) Rambler Style SFR - 1997 UBC	2000
New	27 x 44 2000 Marlette		2000
New	2646 sf 2-story w/703 sf garage and 49 sf covered deck/porch		2000
New	3017 sf 2-story w/967 sf garage and 72 sf covered deck/porch		2000
New	2-Story SFR w/attached garage.		2000
New	Two-story SFR w/attached garage		2000
New	1 story sfr w/ attached 2 car garage		2000
New	Approved Basic #99-102547BP	Plan: 1484 Two Story SFR - 1997 UBC	2000
New	Approved Basic #00-102404 BP	Plan: 1228 Rambler Style SFR - 1997 UBC	2000
New	Approved Basic #00-102404 BP	Plan: 1228 Rambler Style SFR - 1997 UBC	2000
New	Approved Basic #00-104538 BP	SFR w/semi-finished basement - 1997 UBC	2000
New	Approved Basic #00-102404 BP	Plan: 1228 Rambler Style SFR - 1997 UBC	2000
New	Approved Basic #00-104538 BP	Plan: 1478 SFR w/semi-finished basement - 1997 U	2000
New	Approved Basic #00-104538 BP	Plan: 1478 SFR w/semi-finished basement - 1997 U	2000
New	One-story SFR w/basement & attached garage		2000
New	Approved Basic #00-104550 BP	SFR w/semi-finished basement - 1997 UBC	2000
New	Approved Basic #00-104538 BP	Plan: 1478 SFR w/semi-finished basement - 1997 U	2000
New	Approved Basic #00-104538 BP	Plan: 1478 SFR w/semi-finished basement - 1997 U	2000
New	Approved Basic #00-104538 BP	Plan: 1478 SFR w/semi-finished basement - 1997 U	2000
New	Approved Basic #00-104538 BP	Plan: 1478 SFR w/semi-finished basement - 1997 U	2000
New	Approved Basic #00-102404 BP	Plan: 1228 Rambler Style SFR - 1997 UBC	2000
New	One-story SFR w/semi-finished basement & garage		2000
New	Approved Basic #00-102404 BP	Plan: 1228 Rambler Style SFR - 1997 UBC	2000
New	1228 s.f. rambler w/2 car garage		2000
New	Approved Basic #99-102547BP	Plan: 1484 Two Story SFR - 1997 UBC	2000
New	Approved Basic #00-103702 BP	Plan #493 B - end Two Story SFR - 1997 UBC	2000
New	Approved Basic #00-101735 BP	Plan: 394 (post & beam & continuous footing) Tri-level SFR	2000
New	Approved Basic #00-102916 BP	Plan #496 B - crawl space Two Story SFR - 1997 UBC	2000
New	Approved Basic #98-109549BP	Two Story SFR - 1997 UBC	Plan #496 A, 2000
New	Approved Basic #00-101735 BP	Plan: 394 (post & beam & continuous footing) Tri-level SFR	2000
New	Approved Basic #00-102916 BP	Plan #496 Elev B - crawl space Two Story SFR - 1997 U	2000
New	Approved Basic #00-101732 BP	Plan: 486 w/bonus Two Story SFR - 1997 UBC	2000
New	Approved Basic #00-101733 BP	Plan #496 A - crawl space Two Story SFR - 1997 UBC	2000
New	Approved Basic #00-101735 BP	Plan: 394 (post & beam & continuous footing) Tri-level SFR	2000
New	Approved Basic #00-101732 BP	Plan: 486 w/bonus Two Story SFR - 1997 UBC	2000
New	Approved Basic #00-102916 BP	Plan #496 Elev. B - crawl space Two Story SFR - 1997 U	2000
New	Approved Basic #00-101732 BP	Two Story SFR - 1997 UBC	Plan #4: 2000
New	Approved Basic #00-101732 BP	Two Story SFR - 1997 UBC	Plan #4: 2000
New	Approved Basic #00-108422 BP	Plan: 394(3)A Two Story SFR w/finished lc	2000
New	Approved Basic #00-101733 BP	Plan #496 Elev. A - crawl space Two Story SFR - 1997 U	2000
New	Approved Basic #00-101735 BP	Plan: 394 A (post & beam & continuous footing) Tri-level SFF	2000
New	Tri-Level SFR - 1997 UBC	Plan: 394 (3) A	2000
New	2-story SFR.....1997 UBC	Bldrs Plan No.: 598-2A	2000
New	1501 sf rambler w/1501 sf finished basement, 585 sf garage and 891 sf covered deck/porch		2000
New	Two Story SFR - 1997 UBC	Plan: 4005/4105	2000

Accessory Dwelling Units

Index # - File Name: 1.0022 - Single Family Dwellings Data\_Snohomish County.pdf

New	Approved Basic #99-101211BP	Two Story SFR - 1997 UBC	Plan: 5023/5123 w	2000
New	Approved Basic #00-104044 BP		Plan: 4005 B Two Story SFR - 1997 UBC	2000
New	Approved Basic #99-103342BP	Plan: 5222 Two Story SFR - 1997 UBC	OPTION	2000
New	Approved Basic #99-101211BP	Two Story SFR - 1997 UBC	Plan: 5023/5123 w	2000
New	Approved Basic #99-103342BP	Plan: 5222 Two Story SFR - 1997 UBC		2000
New	Approved Basic #00-104042 BP		Plan: 4105 B Two Story SFR - 1997 UBC	2000
New	Approved Basic #99-101211BP	Two Story SFR - 1997 UBC	Plan: 5023/5123 w	2000
New	Approved Basic #99-101214BP	Two Story SFR - 1997 UBC	Plan: 5223/5323 w/t	2000
New	Approved Basic #99-103342BP		Plan: 5222 Two Story SFR - 1997	2000
New	Approved Basic #99-114154 BP		Plan: 5122 w/o bonus Two Story SFR	2000
New	Approved Basic #99-101211BP	Two Story SFR - 1997 UBC	Plan: 5023/5123 w	2000
New	Approved Basic #00-104042 BP		Plan: 4105 B Two Story SFR - 1997 UBC	2000
New	Approved Basic #99-103342BP		Plan: 5222 Two Story SFR - 1997	2000
New	Approved Basic #99-114270 BP		Plan: 4202 A Two Story SFR - 1997 UBC	2000
New	Approved Basic #99-103342BP	Plan: 5222 Two Story SFR - 1997 UBC		2000
New	Approved Basic #99-101211BP	Two Story SFR - 1997 UBC	Plan: 5023/5123 w	2000
New	Mid-Entry SFR w/basement garage.			2000
New	2-Story SFR w/attached 3-car garage.			2000
New	2-Story SFR w/attached 3-car garage.			2000
New	2-Story SFR w/attached 3-car garage.			2000
New	2-Story SFR w/attached 3-car garage.			2000
New	2-Story SFR w/attached 3-car garage.			2000
New	2-Story Sfr w/attached 3-car garage.			2000
New	Approved Basic #00-102876 BP		Plan: #2528 Two Story SFR - 1997 UBC	2000
New	Approved Basic #00-103039 BP		Plan: 2834 Two Story SFR - 1997 UBC	2000
New	2 story sfr w/2 car garage			2000
New	2 story sfr w/2 car garage			2000
New	Approved Basic #98-109883BP	Two Story SFR - 1997 UBC	Plan: #244	2000
New	2 story SFR with finished basement and attached garage			2000
New	Approved Basic #99-114275 BP		Plan: 1653 A/B Two Story SFR - 1997	2000
New	Approved Basic #99-114275 BP		Plan: 1653 A/B Two Story SFR - 1997	2000
New	Approved Basic #99-113398 BP		Plan: 1445 A/B Two Story SFR - 1997 U	2000
New	Approved Basic #99-113405 BP		Plan: #1516 A/B Two Story SFR - 1997	2000
New	Approved Basic #99-113394 BP		Plan: #1409 A/B Two Story SFR - 1997	2000
New	Approved Basic #99-113398 BP		Plan: 1445 A/B Two Story SFR - 1997 U	2000
New	Approved Basic #99-113394 BP		Plan: #1409 A/B Two Story SFR - 1997	2000
New	Approved Basic #99-113405 BP		Plan: #1516 A/B Two Story SFR - 1997	2000
New	Approved Basic #99-113394 BP		Plan: #1409 A/B Two Story SFR - 1997	2000
New	Approved Basic #99-113398 BP		Plan: 1445 A/B Two Story SFR - 1997 U	2000
New	Approved Basic #99-113405 BP		Plan: #1516 A/B Two Story SFR - 1997	2000
New	Approved Basic #99-113405 BP		Plan: #1516 A/B Two Story SFR - 1997	2000
New	Approved Basic #99-113394 BP		Plan: #1409 A/B Two Story SFR - 1997	2000
New	Approved Basic #99-113398 BP		Plan: 1445 A/B Two Story SFR - 1997 U	2000
New	Approved Basic #99-114275 BP		Plan: 1653 A/B Two Story SFR - 1997	2000
New	Approved Basic #99-114275 BP		Plan: 1653 A/B Two Story SFR - 1997	2000
New	Approved Basic #99-114275 BP		Plan: 1653 A/B Two Story SFR - 1997	2000

Accessory Dwelling Units

Index # - File Name: 1.0022 - Single Family Dwellings Data\_Snohomish County.pdf

New	Approved Basic #99-114275 BP	Plan: 1653 A/B Two Story SFR - 1997	2000
New	Two Story SFR with Attached Garage	Bldrs Plan 1653	2000
New	Approved Basic #99-113398 BP	Plan: 1445 A/B Two Story SFR - 1997 UI	2000
New	Approved Basic #99-113405 BP	Plan: #1516 A/B Two Story SFR - 1997	2000
New	Rambler style SFR.....1997 UBC		2000
New	Approved Basic #00-105956 BP	Plan: Brittany Two Story SFR - 1997 UBC	2000
New	Approved Basic #00-106097 BP	Plan: 2415 Two Story SFR - 1997 UBC	2000
New	Approved Basic #00-104350 BP	Plan: 2535 A/3 Two Story SFR - 1997 UBC	2000
New	Approved Basic #00-108901 BP	Plan #2268 Two Story SFR.....1997 UBC	2000
New	Approved Basic #00-103047 BP	Plan: 2430 Two Story SFR - 1997 UBC	2000
New	Two Story SFR w/unfinished basement - 1997 UBC	Plan: 2137 D-B	2000
New	Approved Basic #00-106097 BP	Plan: 2415 Two Story SFR - 1997 UBC	2000
New	Approved Basic #99-116087 BP	Plan: 2637 Two Story SFR - 1997 UBC	2000
New	Approved Basic #00-100924 BP	Plan: 2405 Two Story SFR - 1997 UBC	2000
New	Approved Basic #98-110337BP	Plan #2146 E Two Story SFR with Att	2000
New	Approved Basic #00-107245 BP	Plan: 2052 - front load (revised) Two Story SFR -	2000
New	Approved Basic #00-106104 BP	Plan: 2637 Two Story SFR - 1997 UBC	2000
New	Approved Basic #00-103049 BP	Plan: 2076 Two Story SFR - 1997 UBC	2000
New	Approved Basic #00-106097 BP	Plan: 2415 Two Story SFR - 1997 UBC	2000
New	2-story SFR with attached garage		2000
New	Approved Basic #00-106102 BP	Plan: Waterbrooke Two Story SFR - 1997 UE	2000
New	Approved Basic #99-116087 BP	Plan: 2637 revised Two Story SFR - 1997 UB	2000
New	Two Story SFR - 1997 UBC	Plan: 2386	2000
New	Approved Basic #00-106010 BP	Plan: 2342 Two Story SFR - 1997 UBC	2000
New	One-story duplex w/attached garage		2000
New	Approved Basic #99-103777BP	Plan: 2415 A/3 Two Story SFR - 1997 UBC	2000
New	2-Story SFR w/attached garage.		2000
New	Approved Basic #00-106010 BP	Plan: 2342 Two Story SFR - 1997 UBC	2000
New	Approved Basic #00-103949 BP	Plan: 2415 Two Story SFR - 1997 UBC	2000
New	Approved Basic #99-116024BP	Plan: Avalon Two Story SFR - 1997 UBC	2000
New	Approved Basic #00-100924 BP	Plan: 2405 Two Story SFR - 1997 UBC	2000
New	Approved Basic #98-108364BP	Plan #1837 Two Story SFR - 1997	2000
New	Approved Basic #00-107245 BP	Plan: 2052 - front load (revised) Two Story SFR -	2000
New	Approved Basic #00-107246 BP	Plan: 2052 - side load Two Story SFR - 1997 UBC	2000
New	Approved Basic #99-116024BP	Plan: Avalon Two Story SFR - 1997 UBC	2000
New	Two Story SFR - 1997 UBC	Plan: 2223	2000
New	Approved Basic #00-106939 BP	Plan: 2390 Two Story SFR - 1997 UBC	2000
New	Approved Basic #00-106939 BP	Plan: 2390 Two Story SFR - 1997 UBC	2000
New	Approved Basic #98-150960BP Two Story SFR - 1997 UBC	Plan: 2329	2000
New	Approved Basic #99-116087 BP	Plan: 2637 (revised) Two Story SFR - 1997 U	2000
New	Approved Basic #99-103777BP	Plan: 2415 A/3 Two Story SFR - 1997 UBC	2000
New	Approved Basic #00-103949 BP	Plan: 2415 Two Story SFR - 1997 UBC	2000
New	Approved Basic #99-116024BP	Plan: Avalon Two Story SFR - 1997 UBC	2000
New	Approved Basic #00-106010 BP	Plan: 2342 Two Story SFR - 1997 UBC	2000
New	Approved Basic #00-106939 BP	Plan: 2390 Two Story SFR - 1997 UBC	2000
New	Approved Basic #00-109305 BP	Plan: 2070 Two Story SFR - 1997 UBC	2000
New	2-Story SFR w/attached Garage.		2000

Accessory Dwelling Units

Index # - File Name: 1.0022 - Single Family Dwellings Data\_Snohomish County.pdf

New	1775 s.f. rambler w/2 car garage		2000
New	Approved Basic #99-109807 BP	Plan: 2768 Two Story SFR - 1997 UBC	2000
New	Approved Basic #99-109807 BP	Plan: 2768 Two Story SFR - 1997 UBC	2000
New	Two Story SFR - 1997 UBC	Plan: 2113 Elev. A	2000
New	Approved Basic #00-101967 BP	Plan: #2575 (Elev. B) Two Story SFR - 1997 UBC	2000
New	Approved Basic #00-101968 BP	Plan: #2575 (Elev. C) Two Story SFR - 1997 UBC	2000
New	Approved Basic #00-101967 BP	Plan: #2575 (Elev. B) Two Story SFR - 1997 UBC	2000
New	Approved Basic #99-109807 BP	Plan: 2768 Two Story SFR - 1997 UBC	2000
New	Two Story SFR - 1997 UBC	Plan: 2621	2000
New	Approved Basic #99-109807 BP	Plan: 2768 Two Story SFR - 1997 UBC	2000
New	Approved Basic #00-101970 BP	Plan: #2990 (Elev. B) Two Story SFR - 1997 UBC	2000
New	Approved Basic #00-101974 BP	Plan: #2446 (Elev. C) Two Story SFR - 1997 UBC	2000
New	Approved Basic #00-101972 BP	Plan: #2446 (Elev. A) Two Story SFR - 1997 UBC	2000
New	Approved Basic #99-112258 BP	Plan: 3405 Elev. A Two Story SFR - 1997 UBC	2000
New	Approved Basic #00-101970 BP	Plan: #2990 (Elev. B) Two Story SFR - 1997 UBC	2000
New	Approved Basic #00-101974 BP	Plan: #2446 (Elev. C) Two Story SFR - 1997 UBC	2000
New	Approved Basic #99-110099 BP	Plan: #2148 Elev A Two Story SFR - 1997	2000
New	Approved Basic #00-101972 BP	Plan: #2446 (Elev. A) Two Story SFR - 1997 UBC	2000
New	Approved Basic #00-101967 BP	Plan: #2575 (Elev. B) Two Story SFR - 1997 UBC	2000
New	Approved Basic #99-113027 BP	Plan: 2621 Two Story SFR - 1997 U	2000
New	Approved Basic #99-109807 BP	Plan: 2768 Two Story SFR - 1997 UBC	2000
New	2-story SFR.....1997 UBC		2000
New	Approved Basic #99-109807 BP	Plan: 2768 Two Story SFR - 1997 UBC	2000
New	Approved Basic #99-109807 BP	Plan: 2768 Two Story SFR - 1997 UBC	2000
New	Two Story SFR - 1997 UBC	Plan: 3323	2000
New	Approved Basic #99-109807 BP	Plan: 2768 Two Story SFR - 1997 UBC	2000
New	Approved Basic #99-113027 BP	Plan: 2621 Two Story SFR - 1997 U	2000
New	Approved Basic #99-109807 BP	Plan: 2768 Two Story SFR - 1997 UBC	2000
New	Approved Basic #99-113027 BP	Plan: 2621 Two Story SFR - 1997 U	2000
New	1939 s.f. rambler		2000
New	Approved Basic #00-101974 BP	Plan: #2446 (Elev. C) Two Story SFR - 1997 UBC	2000
New	Approved Basic #00-101967 BP	Plan: #2575 (Elev. B) Two Story SFR - 1997 UBC	2000
New	Approved Basic #00-101974 BP	Plan: #2446 (Elev. C) Two Story SFR - 1997 UBC	2000
New	Approved Basic #99-112258 BP	Plan: 3405 Elev. A Two Story SFR - 19	2000
New	Approved Basic #00-101971 BP	Plan: #2990 (Elev. C) Two Story SFR - 1997 UBC	2000
New	Approved Basic #00-101970 BP	Plan: #2990 (Elev. B) Two Story SFR - 1997 UBC	2000
New	Approved Basic #00-101967 BP	Plan: #2575 (Elev. B) Two Story SFR - 1997 UBC	2000
New	Approved Basic #00-101971 BP	Plan: #2990 (Elev. C) Two Story SFR - 1997 UBC	2000
New	Approved Basic #99-112258 BP	Plan: 3405 Elev. A Two Story SFR - 1997 UBC	2000
New	Two Story SFR - 1997 UBC	Plan: 2129 Elev. A. PERMIT SENT TO MICROFICHE 8/18/1	2000
New	Approved Basic #00-101971 BP	Plan: #2990 (Elev. C) Two Story SFR - 1997 UBC	2000
New	Approved Basic #99-112259 BP	Plan: 3405 Elev. B Two Story SFR - 1997 UBC	2000
New	Approved Basic #00-101970 BP	Plan: #2990 (Elev. B) Two Story SFR - 1997 UBC	2000
New	Approved Basic #00-108829 BP	Plan: 2113 Elev. A Two Story SFR - 1997 UBC	2000
New	Approved Basic #99-112259 BP	Plan: 3405 Elev. B Two Story SFR - 1997 U	2000
New	Approved Basic #99-115032 BP	Plan: 3319 Elv A Two Story SFR - 19	2000
New	Approved Basic #99-110098 BP	Two Story SFR - 1997 UBC Plan: #21	2000



Accessory Dwelling Units

Index # - File Name: 1.0022 - Single Family Dwellings Data\_Snohomish County.pdf

New	Approved Basic #99-112259 BP	Plan: 3405 Elev. B Two Story SFR - 1997 UBC	2000
New	Approved Basic #00-101974 BP	Plan: #2446 (Elev. C) Two Story SFR - 1997 UBC	2000
New	Approved Basic #00-101971 BP	Plan: #2990 (Elev. C) Two Story SFR - 1997 UBC	2000
New	Approved Basic #00-101970 BP	Plan: #2990 (Elev. B) Two Story SFR - 1997 UBC	2000
New	Approved Basic #99-112258 BP	Plan: 3405 Elev. A Two Story SFR - 19	2000
New	Approved Basic #00-101971 BP	Plan: #2990 (Elev. C) Two Story SFR - 1997 UBC	2000
New	Approved Basic #99-112259 BP	Plan: 3405 Elev. B Two Story SFR - 1997 UBC	2000
New	Approved Basic #00-101972 BP	Plan: #2446 (Elev. A) Two Story SFR - 1997 UBC	2000
New	Approved Basic #00-101321 BP	Plan: 1632 Two Story SFR - 1997 UBC	2000
New	Approved Basic #99-116416 BP	Plan: 1567 Tri-Level SFR - 1997 UBC	2000
New	Approved Basic #98-109410BP	Plan: 1644 Split Level SFR - 1997 UBC	2000
New	Approved Basic #99-116416 BP	Plan: 1567 Tri-Level SFR - 1997 UBC	2000
New	Approved Basic #00-101321 BP	Plan: 1632 Two Story SFR - 1997 UBC	2000
New	Approved Basic #98-109410BP	Plan: 1644 Split Level SFR - 1997 UBC	2000
New	Approved Basic #99-101587BP	2 Story SFR/ 2 car garage Plan #	2000
New	Approved Basic #98-109408BP	Plan: 1705 SFR w/finished lower floor - 1997	2000
New	Approved Basic #99-116416 BP	Plan: 1567 Tri-Level SFR - 1997 UBC	2000
New	Approved Basic #00-101321 BP	Plan: 1632 Two Story SFR - 1997 UBC	2000
New	Approved Basic #99-116416 BP	Plan: 1567 Tri-Level SFR - 1997 UBC	2000
New	Approved Basic #00-106367 BP	Plan: 1705 crawl SFR w/finished lower floor	2000
New	Approved Basic #98-109410BP	Plan: 1644 Split Level SFR - 1997 UBC	2000
New	Approved Basic #99-101587BP	2 Story SFR/ 2 car garage Plan #	2000
New	Approved Basic #98-109408BP	Plan: 1705 SFR w/finished lower floor - 1997	2000
New	Approved Basic #99-101587BP	2 Story SFR/ 2 car garage Plan #	2000
New	Approved Basic #98-109408BP	Plan: 1705 slab SFR w/finished lower floor - 1	2000
New	Approved Basic #99-101587BP	Two Story SFR/ 2 car garage Pla	2000
New	Approved Basic #00-106367 BP	Plan: 1705 crawl SFR w/finished lower floor	2000
New	2-story SFR.....1997 UBC	Bldrs Plan No. 2119	2000
New	Approved Basic #00-106811 BP	Plan: 1644 revised Split Level SFR - 1997 UBC	2000
New	Two Story SFR -1997 UBC		2000
New	SFR w/semi-finished lower floor - 1997 UBC		2000
New	SFR w/semi-finished lower floor - 1997 UBC		2000
New	Two Story SFR w/finished basement - 1997 UBC		2000
New	Approved Basic #00-106811 BP	Plan: 1644 revised Split Level SFR - 1997 UBC	2000
New	SFR w/semi-finished lower floor - 1997 UBC		2000
New	Two Story SFR w/finished basement - 1997 UBC		2000
New	Approved Basic #00-106811 BP	Plan: 1644 revised Split Level SFR - 1997 UBC	2000
New	2-story SFR.....1997 UBC	Bldrs Plan No. 2360 3-car	2000
New	Approved Basic #99-116416 BP	Plan: 1567 Tri-Level SFR - 1997 UBC	2000
New	Approved Basic #00-106367 BP	Plan: 1705 crawl SFR w/finished lower floor	2000
New	Approved Basic No. 00-107063 BP	Bldrs Plan No. 2119 2-story style SFR....1997 U	2000
New	2-story SFR.....1997 UBC	Bldrs Plan No. 2471	2000
New	Approved Basic #00-107067 BP	Bldrs Plan No. 1786 2-story style SFR.....1997 U	2000
New	Approved Basic #00-106450 BP	Plan: 1567 Revised Tri-Level SFR - 1997 UBC	2000
New	2-story SFR.....1997 UBC	Bldrs Plan No. 2360 2-car	2000
New	Approved Basic #00-101321 BP	Plan: 1632 Two Story SFR - 1997 UBC	2000
New	Approved Basic #99-101587BP	2 Story SFR/ 2 car garage Plan #	2000

Accessory Dwelling Units

Index # - File Name: 1.0022 - Single Family Dwellings Data\_Snohomish County.pdf

New	Approved Basic #00-106367 BP	Plan: 1705 crawl SFR w/finished lower floor - 1997 UBC	2000
New	Approved Basic #99-101587BP	2 Story SFR/ 2 car garage	Plan # 2000
New	2-story SFR.....1997 UBC	Bldrs Plan No. 1786	2000
New	2 Story SFR w/2 Car Garage		2000
New	Approved Basic #99-116016 BP	Plan: 1450 Split Level SFR - 1997 UBC	2000
New	Approved Basic #98-109410BP	Plan: 1644 Split Level SFR - 1997 UBC	2000
New	Approved Basic #99-101587BP	2 Story SFR/ 2 car garage	Plan # 2000
New	Approved Basic #00-106367 BP	Plan: 1705 crawl SFR w/finished lower floor	2000
New	Approved Basic #99-101587BP	2 Story SFR/ 2 car garage	Plan # 2000
New	Approved Basic #00-106367 BP	Plan: 1705 crawl SFR w/finished lower floor	2000
New	Approved Basic #00-106450 BP	Plan: 1567 Revised Tri-Level SFR - 1997 UBC	2000
New	Approved Basic #00-106811 BP	Plan: 1644 revised Split Level SFR - 1997 UBC	2000
New	Approved Basic #00-101321 BP	Plan: 1632 Two Story SFR - 1997 UBC	2000
New	Approved Basic #00-106367 BP	Plan: 1705 crawl SFR w/finished lower floor	2000
New	Approved Basic #99-116016 BP	Plan: 1450 Split Level SFR - 1997 UBC	2000
New	Approved Basic #00-101321 BP	Plan: 1632 Two Story SFR - 1997 UBC	2000
New	Approved Basic #99-116416 BP	Plan: 1567 Tri-Level SFR - 1997 UBC	2000
New	Approved Basic #00-106811 BP	Plan: 1644 revised Split Level SFR - 1997 UBC	2000
New	Approved Basic #99-116416 BP	Plan: 1567 Tri-Level SFR - 1997 UBC	2000
New	Approved Basic #99-101587BP	2 Story SFR/ 2 car garage	Plan # 2000
New	Approved Basic #00-106367 BP	Plan: 1705 crawl SFR w/finished lower floor	2000
New	Approved Basic #99-101587BP	2 Story SFR/ 2 car garage	Plan # 2000
New	Approved Basic #00-106811 BP	Plan: 1644 revised Split Level SFR - 1997 UBC	2000
New	Approved Basic #99-101587BP	2 Story SFR/ 2 car garage	Plan # 2000
New	Approved Basic #99-101587BP	2 Story SFR/ 2 car garage	Plan # 2000
New	Approved Basic #98-109408BP	Plan: 1705 slab SFR w/finished lower floor - 1	2000
New	2-story SFR.....1997 UBC		2000
New	Approved Basic #00-103095 BP	Plan: 1960 Elev. A Mid-Entry SFR - 1997 UBC	2000
New	Approved Basic #00-103095 BP	Plan: 1960 Elev. A Mid-Entry SFR - 1997 UBC	2000
New	Approved Basic #00-103095 BP	Plan: 1960 Elev. A Mid-Entry SFR - 1997 UBC	2000
New	Mid - Entry SFR - 1997 UBC	Plan No. 2183	2000
New	Rambler style SFR w/recreation/bar room over 3-bay garage....1997 UBC		2000
New	Approved Basic #00-100575 BP	Plan: 99-20 Two Story SFR - 1997 UBC	2000
New	Approved Basic #00-101256 BP	Plan: 99-24 Two Story SFR - 1997 UBC	2000
New	Approved Basic #00-101467 BP	Plan: 99-23 Two Story SFR - 1997 UBC	2000
New	Approved Basic #00-101252 BP	Plan: 99-21 Two Story SFR - 1997 UBC	2000
New	Approved Basic #00-101256 BP	Plan: 99-24 Two Story SFR - 1997 UBC	2000
New	Approved Basic #00-100570 BP	Plan: 99-22 Two Story SFR - 1997 UBC	2000
New	Approved Basic #00-101256 BP	Plan: 99-24 Two Story SFR - 1997 UBC	2000
New	Approved Basic #00-100570 BP	Plan: 99-22 Two Story SFR - 1997 UBC	2000
New	Approved Basic #00-101252 BP	Plan: 99-21 Two Story SFR - 1997 UBC	2000
New	Approved Basic #00-101256 BP	Plan: 99-24 Two Story SFR - 1997 UBC	2000
New	Approved Basic #00-101252 BP	Plan: 99-21 Two Story SFR - 1997 UBC	2000
New	Approved Basic #00-101256 BP	Plan: 99-24 Two Story SFR - 1997 UBC	2000
New	Approved Basic #00-100570 BP	Plan: 99-22 Two Story SFR - 1997 UBC	2000
New	Approved Basic #00-101467 BP	Plan: 99-23 Two Story SFR - 1997 UBC	2000
New	Approved Basic #00-101256 BP	Plan: 99-24 Two Story SFR - 1997 UBC	2000

Accessory Dwelling Units

Index # - File Name: 1.0022 - Single Family Dwellings Data\_Snohomish County.pdf

New	Approved Basic #00-100570 BP	Plan: 99-22 Two Story SFR - 1997 UBC	2000
New	Approved Basic #00-101252 BP	Plan: 99-21 Two Story SFR - 1997 UBC	2000
New	Approved Basic #00-101256 BP	Plan: 99-24 Two Story SFR - 1997 UBC	2000
New	Approved Basic #00-100570 BP	Plan: 99-22 Two Story SFR - 1997 UBC	2000
New	Approved Basic #00-101256 BP	Plan: 99-24 Two Story SFR - 1997 UBC	2000
New	Approved Basic #00-100570 BP	Plan: 99-22 Two Story SFR - 1997 UBC	2000
New	Approved Basic #00-101252 BP	Plan: 99-21 Two Story SFR - 1997 UBC	2000
New	Approved Basic #00-101256 BP	Plan: 99-24 Two Story SFR - 1997 UBC	2000
New	Approved Basic #00-100570 BP	Plan: 99-22 Two Story SFR - 1997 UBC	2000
New	Approved Basic #00-101252 BP	Plan: 99-21 Two Story SFR - 1997 UBC	2000
New	Approved Basic #00-101467 BP	Plan: 99-23 Two Story SFR - 1997 UBC	2000
New	Approved Basic #00-100570 BP	Plan: 99-22 Two Story SFR - 1997 UBC	2000
New	Approved Basic #00-101252 BP	Plan: 99-21 Two Story SFR - 1997 UBC	2000
New	Approved Basic #00-101256 BP	Plan: 99-24 Two Story SFR - 1997 UBC	2000
New	Approved Basic #00-100570 BP	Plan: 99-22 Two Story SFR - 1997 UBC	2000
New	Approved Basic #00-101252 BP	Plan: 99-21 Two Story SFR - 1997 UBC	2000
New	Approved Basic #00-101256 BP	Plan: 99-24 Two Story SFR - 1997 UBC	2000
New	Approved Basic #00-100570 BP	Plan: 99-22 Two Story SFR - 1997 UBC	2000
New	Approved Basic #00-101467 BP	Plan: 99-23 Two Story SFR - 1997 UBC	2000
New	Approved Basic #00-100575 BP	Plan: 99-20 Two Story SFR - 1997 UBC	2000
New	Approved Basic #00-101252 BP	Plan: 99-21 Two Story SFR - 1997 UBC	2000
New	Approved Basic #00-101252 BP	Plan: 99-21 Two Story SFR - 1997 UBC	2000
New	Approved Basic #00-101467 BP	Plan: 99-23 Two Story SFR - 1997 UBC	2000
New	Approved Basic #00-101256 BP	Plan: 99-24 Two Story SFR - 1997 UBC	2000
New	Approved Basic #00-100570 BP	Plan: 99-22 Two Story SFR - 1997 UBC	2000
New	Approved Basic #00-101252 BP	Plan: 99-21 Two Story SFR - 1997 UBC	2000
New	Approved Basic #00-100575 BP	Plan: 99-20 Two Story SFR - 1997 UBC	2000
New	Approved Basic #00-101467 BP	Plan: 99-23 Two Story SFR - 1997 UBC	2000
New	Approved Basic #00-100570 BP	Plan: 99-22 Two Story SFR - 1997 UBC	2000
New	Approved Basic #00-101256 BP	Plan: 99-24 Two Story SFR - 1997 UBC	2000
New	Approved Basic #00-101252 BP	Plan: 99-21 Two Story SFR - 1997 UBC	2000
New	Approved Basic #00-100570 BP	Plan: 99-22 Two Story SFR - 1997 UBC	2000
New	Approved Basic #00-101467 BP	Plan: 99-23 Two Story SFR - 1997 UBC	2000
New	Approved Basic #00-100570 BP	Plan: 99-22 Two Story SFR - 1997 UBC	2000
New	Approved Basic #00-101252 BP	Plan: 99-21 Two Story SFR - 1997 UBC	2000
New	Approved Basic #00-101256 BP	Plan: 99-24 Two Story SFR - 1997 UBC	2000
New	Approved Basic #00-101256 BP	Plan: 99-24 Two Story SFR - 1997 UBC	2000
New	Approved Basic #00-106811 BP	Plan: 1644 revised Split Level SFR - 1997 UBC	2000
New	Approved Basic #00-106367 BP	Plan: 1705 crawl SFR w/finished lower floor	2000
New	Approved Basic #00-106811 BP	Plan: 1644 revised Split Level SFR - 1997 UBC	2000
New	Approved Basic #00-106367 BP	Plan: 1705 crawl SFR w/finished lower floor	2000
New	Rambler style SFR.....1997 UBC		2000
New	2 Story SFR with Garage.		2000
New	Approved Basic #99-112089 BP	Plan 2031 Two Story SFR - 1997 U	2000
New	Approved Basic #98-109153BP	Plan 2031 Two Story SFR - 1997 UI	2000
New	Approved Basic #98-109153BP	Plan 2031 Two Story SFR - 1997 UI	2000
New	Two Story SFR w/unfinished basement - 1997 UBC	Plan: 1833 w/basement	2000

Accessory Dwelling Units

Index # - File Name: 1.0022 - Single Family Dwellings Data\_Snohomish County.pdf

New	Rambler style SFR.....1997 UBC			2000
New	Approved Basic #99-112089 BP		Plan: 2031 Two Story SFR - 1997 UBC	2000
New	Approved Basic #99-102335BP		Plan 1833 w/bonus Two Story SFR - 1997 UBC	2000
New	28x50, 1995 Nassau			2000
New	Approved Basic #00-108117 BP		Plan 1528 Two Story SFR.....1997 UBC	2000
New	Approved Basic #98-116237 BP		Plan 8812 Tri-Level SFR - 1997 UBC	2000
New	Approved Basic #00-106279 BP		Plan 1805 Two Story SFR.....1997 UBC	2000
New	Approved Basic #00-108115 BP		Plan 8808 X Tri-Level SFR - 1997 UBC	2000
New	Approved Basic #00-106279 BP		Plan 1805 Two Story SFR.....1997 UBC	2000
New	Approved Basic #98-116237 BP		Plan 8812 Tri-Level SFR - 1997 UBC	2000
New	Approved Basic #98-116713BP		Plan: 1765 Two Story SFR - 1997 UBC	2000
New	Approved Basic #00-108117 BP		Plan 1528 Two Story SFR.....1997 UBC	2000
New	Approved Basic #98-1167BP		Plan: 1765 Two Story SFR - 1997 UBC	2000
New	Approved Basic #00-108117 BP		Plan 1528 Two Story SFR.....1997 UBC	2000
New	Two Story SFR with Attached Garage.			2000
New	1996 Golden West Winterhaven 27 x 52			2000
New	24 x 40 2000 Redman			2000
New	Approved Basic #98-116237 BP		Plan 8812 Tri-Level SFR - 1997 UBC	2000
New	Approved Basic #00-106279 BP		Plan 1805 Two Story SFR.....1997 UBC	2000
New	Approved Basic #00-106278 BP		Plan 1528 Two Story SFR.....1997 UBC	2000
New	Approved Basic #00-106279 BP		Plan 1805 Two Story SFR.....1997 UBC	2000
New	Approved Basic #00-106758 BP		Plan: E Two Story SFR - 1997 UBC	2000
New	Approved Basic #00-107478 BP		Plan: B Two Story SFR - 1997 UBC	2000
New	Two Story SFR - 1997 UBC	Plan: E3	0 Lot	2000
New	Two Story SFR - 1997 UBC	Plan: B-1	0 Lot	2000
New	Approved Basic #00-106754 BP		Plan: C Two Story SFR - 1997 UBC	2000
New	Two Story SFR - 1997 UBC	Plan: A1	0 Lot I	2000
New	Approved Basic #00-106758 BP		Plan: E Two Story SFR - 1997 UBC	2000
New	Approved Basic #00-107481 BP		Plan: D Two Story SFR - 1997 UBC	2000
New	Two Story SFR - 1997 UBC	Plan: C1		2000
New	Two Story SFR - 1997 UBC	Plan: D1		2000
New	Approved Basic #00-107478 BP		Plan: B Two Story SFR - 1997 UBC	2000
New	Approved Basic #00-107481 BP		Plan: D Two Story SFR - 1997 UBC	2000
New	Approved Basic #00-107485 BP		Plan: A Two Story SFR - 1997 UBC	2000
New	*Issued under tax roll # 280529-004-025-00* Tri-Level SFR w/unfinished basement....1997 UBC			2000
New	Two Story SFR - 1997 UBC		Plan: 1927 2/3	2000
New	Mid-entry Style SFR with finished basement and basement garage.			2000
New	Split Level Style SFR with attached garage			2000
New	Approved Basic #99-109632 BP		Elevation A Two Story SFR - 1997 UBC	2000
New	Approved Basic #00-100867 BP		Plan: 2220 Mid Entry SFR - 1997 UBC	2000
New	Mid-entry style SFR w/finished basement & basement garage.			2000
New	Approved Basic #00-106859 BP		Plan: 1927 Two Story SFR - 1997 UBC	2000
New	Approved Basic #00-106859 BP		Plan: 1927 Two Story SFR - 1997 UBC	2000
New	Approved Basic #99-113717 BP		Plan: #2002 Two Story SFR - 1997 UBC (	2000
New	Approved Basic #99-109632 BP		Elevation A Two Story SFR - 1997 UBC	2000
New	Approved Basic No. 00-105673 BP		Plan No. 2346 Mid - Entry SFR - 1997 UBC	2000
New	Approved Basic #99-113717 BP		Plan: #2002 Two Story SFR - 1997 UBC (	2000

Accessory Dwelling Units

Index # - File Name: 1.0022 - Single Family Dwellings Data\_Snohomish County.pdf

New	Approved Basic #00-100867 BP	Plan: 2220	Mid Entry SFR - 1997 UBC	2000
New	Approved Basic No. 00-105673 BP	Plan No. 2346	Mid - Entry SFR - 1997 UBC	2000
New	Approved Basic #99-109632 BP	Elevation A	Two Story SFR - 1997 UBC	2000
New	Approved Basic #98-1167BP	Plan: 1765	Two Story SFR - 1997 UBC	2000
New	Approved Basic #98-116235BP	Plan 8812	Tri-Level SFR - 1997	2000
New	*Issued under tax roll # 280529-004-025-00* Two-story SFR w/finished basement & attached g			2000
New	2-story SFR w/attached garage by a mudroom.....1997 UBC			2000
New	1581 s.f. rambler w/2 car garage			2000
New	2 story SFR w/ attached garage			2000
New	Two Story SFR - 1997 UBC	Plan: 2700		2000
New	Two Story SFR - 1997 UBC	Plan: 2303		2000
New	New 1 story SFR w/ attached 3 car garage			2000
New	3140 sf 2-story w/814 sf garage and 209 sf covered deck/porch			2000
New	Approved Basic #00-104082 BP	Two Story Duplex.....1997 UBC		2000
New	Approved Basic #00-104082 BP	Two Story Duplex.....1997 UBC		2000
New	Approved Basic #99-103276BP	Plan: #2461	Two Story SFR - 1997 UBC	2000
New	2955 sf 2-story w/704 sf garage and 106 sf covered deck/porch			2000
New	Approved Basic #99-103276BP	Plan: #2461	Two Story SFR - 1997 UBC	2000
New	2581 sf 2-story w/640 sf garage and 56 sf covered deck/porch			2000
New	Approved Basic #00-102589 BP	Two Story SFR - 1997 UBC		2000
New	Approved Basic #99-103276BP	Plan: #2461	Two Story SFR - 1997 UBC	2000
New	2760 sf 2-story w/609 sf garage and 69 sf covered deck/porch			2000
New	Approved Basic #98-116126BP	Plan 2704	Two Story SFR - 1997 U	2000
New	Approved Basic #98-150658BP	Plan 2210	Two-story SFR w/attach	2000
New	Two-story SFR w/attached garage			2000
New	Two-story SFR w/attached garage			2000
New	Approved Basic #00-101812 BP	Plan: 1601	Two Story SFR -1997 UBC	2000
New	Approved Basic #00-100983 BP	Plan: 1540	Two Story SFR - 1997 UBC	2000
New	Approved Basic #00-101235	Plan: 1893	Two Story SFR - 1997 UBC	2000
New	Approved Basic #99-116273 BP	Plan: 1742	Two Story SFR - 1997 UBC	2000
New	Approved Basic #00-100981 BP	Plan: 1632	Two Story SFR - 1997 UBC	2000
New	Approved Basic #00-100983 BP	Plan: 1540	Two Story SFR - 1997 UBC	2000
New	Approved Basic #99-116273 BP	Plan: 1742	Two Story SFR - 1997 UBC	2000
New	Two Story SFR with Attached Garage			2000
New	Approved Basic #99-111975 BP	Plan: 1533	Two Story SFR - 1997	2000
New	Approved Basic #00-100983 BP	Plan: 1540	Two Story SFR - 1997 UBC	2000
New	Approved Basic #99-116273 BP	Plan: 1742	Two Story SFR - 1997 UBC	2000
New	Approved Basic #00-101235	Plan: 1893	Two Story SFR - 1997 UBC	2000
New	Approved Basic #00-100981 BP	Plan: 1632	Two Story SFR - 1997 UBC	2000
New	Approved Basic #00-100984 BP	Plan: 1521	Two Story SFR - 1997 UBC	2000
New	Approved Basic #00-100981 BP	Plan: 1632	Two Story SFR - 1997 UBC	2000
New	Approved Basic #00-100984 BP	Plan: 1521	Two Story SFR - 1997 UBC	2000
New	Approved Basic #00-100984 BP	Plan: 1521	Two Story SFR - 1997 UBC	2000
New	Approved Basic #99-116273 BP	Plan: 1742	Two Story SFR - 1997 UBC	2000
New	Approved Basic #99-111975 BP	Plan: 1533	Two Story SFR - 1997	2000
New	Approved Basic #00-100983 BP	Plan: 1540	Two Story SFR - 1997 UBC	2000
New	Approved Basic #00-100981 BP	Plan: 1632	Two Story SFR - 1997 UBC	2000

Accessory Dwelling Units

Index # - File Name: 1.0022 - Single Family Dwellings Data\_Snohomish County.pdf

New	Approved Basic #00-100984	Plan: 1521	Two Story SFR - 1997 UBC	2000
New	Approved Basic #99-111975 BP		Plan: 1533 Two Story SFR - 199	2000
New	Approved Basic #99-111975 BP		Plan: 1533 Two Story SFR - 199	2000
New	Approved Basic #00-100983 BP	Plan: 1540	Two Story SFR - 1997 UBC	2000
New	Approved Basic #00-100984 BP	Plan: 1521	Two Story SFR - 1997 UBC	2000
New	Approved Basic #00-100981 BP	Plan: 1632	Two Story SFR - 1997 UBC	2000
New	Approved Basic #00-100981 BP	Plan: 1632	Two Story SFR - 1997 UBC	2000
New	Approved Basic #99-111975 BP		Plan: 1533 Two Story SFR - 199	2000
New	two Story SFR with Attached Garage. DO NOT FINAL per Gerry Shelbreck 3/31/00. 1. Prior to			2000
New	2-story SFR w/attached 2-car garage....1997 UBC. DO NOT FINAL per Gerry Schelbreck 3/31/00			2000
New	Two Story SFR - 1997 UBC	Plan: 1521	DO NOT FINAL. Per Gerry Schelbreck	2000
New	Two Story SFR - 1997 UBC	Plan: 1893	DO NOT FINAL per Gerry Shelbreck 3/31/00	2000
New	Split level SFR w/lower finished floor - 1997 UBC		Plan: 2346-3	2000
New	Approved Basic #99-115493 BP		Plan #1927 Two Story SFR - 1997 UB	2000
New	1999, 27 x 44, Oakwood Dream Home II			2000
New	2-story SFR w/attached 3-car garage....1997 UBC			2000
New	Approved Basic #99-116016 BP	Plan: 1450	Split Level SFR - 1997 UBC	2000
New	Approved Basic #98-109410BP		Plan: 1644 Split Level SFR - 1997 U	2000
New	Approved Basic #99-101587BP 2 Story SFR/ 2 car garage		Plan #	2000
New	Approved Basic #99-101345BP		Plan: 1352 SFR w/unfinished ba	2000
New	CLOSED W/O FINAL. THIS PERMIT PLACED IN NEW PERMIT 02-109042. TRANSFER OF PERMIT /			2000
New	Two story with attached three car garage.			2000
New	Approved Basic #99-101345BP		Plan: 1352 SFR w/unfinished ba	2000
New	Approved Basic #98-109410BP		Plan: 1644 Split Level SFR - 1997 U	2000
New	Approved Basic #00-100528 BP	Plan: 1715	Split Level SFR w/semi-finished low	2000
New	Approved Basic #98-109410BP		Plan: 1644 Split Level SFR - 1997 U	2000
New	Approved Basic #98-109408BP		Plan: 1705 SFR w/finished lower flc	2000
New	Approved Basic #99-116416 BP	Plan: 1567	Tri-Level SFR - 1997 UBC	2000
New	Approved Basic #00-101321 BP		Plan: 1632 Two Story SFR - 1997 UBC	2000
New	Approved Basic #99-116416 BP	Plan: 1567	Tri-Level SFR - 1997 UBC	2000
New	Approved Basic #98-109410BP		Plan: 1644 Split Level SFR - 1997 U	2000
New	Approved Basic #99-101587 BP	Plan: 1514	Two Story SFR - 1997 UBC	2000
New	Approved Basic #98-109408BP		Plan: 1705 SFR w/unfinished lower	2000
New	Approved Basic #99-116016 BP	Plan: 1450	Split Level SFR - 1997 UBC	2000
New	Approved Basic #99-116416 BP	Plan: 1567	Tri-Level SFR - 1997 UBC	2000
New	Approved Basic #00-106367 BP	Plan: 1705 crawl	SFR w/finished lower floor - 1997	2000
New	Approved Basic #99-101587BP 2 Story SFR/ 2 car garage		Plan #	2000
New	Approved Basic #98-109408BP		Plan: 1705 SFR w/finished lower flc	2000
New	Approved Basic #99-116016 BP	Plan: 1450	Split Level SFR - 1997 UBC	2000
New	Approved Basic #98-109408BP		Plan: 1705 SFR w/finished lower flc	2000
New	Approved Basic #99-116416 BP	Plan: 1567	Tri-Level SFR - 1997 UBC	2000
New	Approved Basic #98-109410BP		Plan: 1644 Split Level SFR - 1997 U	2000
New	Approved Basic #99-116016 BP	Plan: 1450	Split Level SFR - 1997 UBC	2000
New	Approved Basic #00-104213 BP	Plan: 5	Two Story SFR - 1997 UBC	2000
New	Approved Basic #00-104215 BP	Plan: 1	Two Story SFR - 1997 UBC	2000
New	Approved Basic #00-104215 BP	Plan: 1	Two Story SFR - 1997 UBC	2000
New	Approved Basic #00-104213 BP	Plan: 5	Two Story SFR - 1997 UBC	2000

Accessory Dwelling Units

Index # - File Name: 1.0022 - Single Family Dwellings Data\_Snohomish County.pdf

New	Approved Basic #99-116216 BP	Plan: 8 a/b Two Story SFR - 1997 UBC	2000
New	Approved Basic #99-116219 BP	Plan: 6 Two Story SFR - 1997 UBC	2000
New	Approved Basic #00-104213 BP	Plan: 5 Two Story SFR - 1997 UBC	2000
New	Approved Basic #00-105890 BP	Plan: 4a Two Story SFR - 1997 UBC	2000
New	Approved Basic #00-104215 BP	Plan: 1 Two Story SFR - 1997 UBC	2000
New	Approved Basic #00-104215 BP	Plan: 1 Two Story SFR - 1997 UBC	2000
New	Approved Basic #00-104213 BP	Plan: 5 Two Story SFR - 1997 UBC	2000
New	2-story SFR w/attached 2-car garage....1997 UBC	Blders Plan No. 8 a/b	2000
New	2-story SFR w/attached 2-car garage...1997 UBC	Blders Plan No. 1	2000
New	2-story SFR w/attached 2-car garage.....1997 UBC	Blders Plan No. 5	2000
New	2 story sfr w/2 car garage		2000
New	Approved Basic #99-116216 BP	Plan: 8 a/b Two Story SFR - 1997 UBC	2000
New	Approved Basic #99-116219 BP	Plan: 6 Two Story SFR - 1997 UBC	2000
New	Approved Basic #99-116219 BP	Plan: 6 Two Story SFR - 1997 UBC	2000
New	Approved Basic #99-116216 BP	Plan: 8 a/b Two Story SFR - 1997 UBC	2000
New	Approved Basic #00-104213 BP	Plan: 5 Two Story SFR - 1997 UBC	2000
New	2000 27 x 44 Greenbrier		2000
New	27x66 1993 Liberty - Glen Oaks		2000
New	Approved Basic #99-116216 BP	Plan: 8 a/b Two Story SFR - 1997 UBC	2000
New	Approved Basic #00-104213 BP	Plan: 5 Two Story SFR - 1997 UBC	2000
New	Approved Basic #00-104215 BP	Plan: 1 Two Story SFR - 1997 UBC	2000
New	2-story SFR w/attached 2-car garage....1997 UBC	Blders Plan No. 2	2000
New	Approved Basic #00-104215 BP	Plan: 1 Two Story SFR - 1997 UBC	2000
New	2 story sfr w/2 car garage	Plan: 4a/c	2000
New	Approved Basic #00-104213 BP	Plan: 5 Two Story SFR - 1997 UBC	2000
New	Approved Basic #99-116216 BP	Plan: 8 a/b Two Story SFR - 1997 UBC	2000
New	Approved Basic #00-104213 BP	Plan: 5 Two Story SFR - 1997 UBC	2000
New	Approved Basic #00-104215 BP	Plan: 1 Two Story SFR - 1997 UBC	2000
New	Approved Basic #00-104213 BP	Plan: 5 Two Story SFR - 1997 UBC	2000
New	Approved Basic #99-116216 BP	Plan: 8 a/b Two Story SFR - 1997 UBC	2000
New	Approved Basic #00-104213 BP	Plan: 5 Two Story SFR - 1997 UBC	2000
New	Approved Basic #00-104215 BP	Plan: 1 Two Story SFR - 1997 UBC	2000
New	Approved Basic #99-116219 BP	Plan: 6 Two Story SFR - 1997 UBC	2000
New	1999 Marlette 27 x 60		2000
New	Two Story SFR		2000
New	Approved Basic #00-103392 BP	Plan: 1715 Two-story SFR w/semi finished ba	2000
New	Approved Basic #00-105975 BP	Plan: 1632 w/basement Two Story SFR w/semi-fi	2000
New	Approved Basic #00-102169 BP	Plan: 022891 SFR w/finished basement - 199	2000
New	Approved Basic #99-116016 BP	Plan: 1450 Split Level SFR - 1997 UBC	2000
New	Approved Basic #00-100528 BP	Plan: 1715 Split Level SFR w/semi-finished low	2000
New	Approved Basic #00-102169 BP	Plan: 022891 SFR w/finished basement - 199	2000
New	Approved Basic #99-116016 BP	Plan: 1450 Split Level SFR - 1997 UBC	2000
New	Approved Basic #00-100528 BP	Plan: 1715 Split Level SFR w/semi-finished low	2000
New	Approved Basic #99-116016 BP	Plan: 1450 Split Level SFR - 1997 UBC	2000
New	Approved Basic #00-102169 BP	Plan: 022891 SFR w/finished basement - 199	2000
New	Approved Basic #99-116016 BP	Plan: 1450 Split Level SFR - 1997 UBC	2000
New	Approved Basic #00-100528 BP	Plan: 1715 Split Level SFR w/semi-finished low	2000

Accessory Dwelling Units

Index # - File Name: 1.0022 - Single Family Dwellings Data\_Snohomish County.pdf

New	Approved Basic #00-102169 BP	Plan: 022891 SFR w/finished basement - 199	2000
New	Approved Basic #99-116016 BP	Plan: 1450 Split Level SFR - 1997 UBC	2000
New	Approved Basic #00-102169 BP	Plan: 022891 SFR w/finished basement - 199	2000
New	Approved Basic #99-116016 BP	Plan: 1450 Split Level SFR - 1997 UBC	2000
New	Approved Basic #00-100528 BP	Plan: 1715 Split Level SFR w/semi-finished low	2000
New	Approved Basic #99-116016 BP	Plan: 1450 Split Level SFR - 1997 UBC	2000
New	Approved Basic #00-102169 BP	Plan: 022891 SFR w/finished basement - 199	2000
New	Approved Basic #99-116016 BP	Plan: 1450 Split Level SFR - 1997 UBC	2000
New	Approved Basic #99-116416 BP	Plan: 1567 Tri-Level SFR - 1997 UBC	2000
New	Approved Basic #00-102759 BP	Plan: 1452 Rambler Style SFR - 1997 UBC	2000
New	Approved Basic #99-116416 BP	Plan: 1567 Tri-Level SFR - 1997 UBC	2000
New	Approved Basic #00-100528 BP	Plan: 1715 Split Level SFR w/semi-finished low	2000
New	Approved Basic #00-102759 BP	Plan: 1452 Rambler Style SFR - 1997 UBC	2000
New	Approved Basic #00-101321 BP	Plan: 1632 Two Story SFR - 1997 UBC	2000
New	Approved Basic #99-116416 BP	Plan: 1567 Tri-Level SFR - 1997 UBC	2000
New	Approved Basic #00-101683 BP	Plan: 1730 SFR w/semi-finished lower floor	2000
New	Approved Basic #99-116016 BP	Plan: 1450 Split Level SFR - 1997 UBC	2000
New	Approved Basic #00-102169 BP	Plan: 022891 SFR w/finished basement - 199	2000
New	Approved Basic #00-102759 BP	Plan: 1452 Rambler Style SFR - 1997 UBC	2000
New	Approved Basic #00-101321 BP	Plan: 1632 Two Story SFR - 1997 UBC	2000
New	Approved Basic #99-116016 BP	Plan: 1450 Split Level SFR - 1997 UBC	2000
New	Approved Basic #00-100528 BP	Plan: 1715 Split Level SFR w/semi-finished low	2000
New	Approved Basic #00-101321 BP	Plan: 1632 Two Story SFR - 1997 UBC	2000
New	Approved Basic #00-101683 BP	Plan: 1730 SFR w/semi-finished lower floor	2000
New	Approved Basic #99-116016 BP	Plan: 1450 Split Level SFR - 1997 UBC	2000
New	Approved Basic #00-102169 BP	Plan: 022891 SFR w/finished basement - 199	2000
New	Approved Basic #00-100528 BP	Plan: 1715 Split Level SFR w/semi-finished l	2000
New	Approved Basic #99-116016 BP	Plan: 1450 Split Level SFR - 1997 UBC	2000
New	Approved Basic #00-100528 BP	Plan: 1715 Split Level SFR w/semi-finished low	2000
New	Approved Basic #00-101683 BP	Plan: 1730 SFR w/semi-finished lower floor	2000
New	Approved Basic #99-116016 BP	Plan: 1450 Split Level SFR - 1997 UBC	2000
New	Approved Basic #00-102169 BP	Plan: 022891 SFR w/finished basement - 199	2000
New	Approved Basic #99-116016 BP	Plan: 1450 Split Level SFR - 1997 UBC	2000
New	Approved Basic #00-100528 BP	Plan: 1715 Split Level SFR w/semi-finished lowe	2000
New	Approved Basic #99-116016 BP	Plan: 1450 Split Level SFR - 1997 UBC	2000
New	Approved Basic #99-116416 BP	Plan: 1567 Tri-Level SFR - 1997 UBC	2000
New	Approved Basic #00-102759 BP	Plan: 1452 Rambler Style SFR - 1997 UBC	2000
New	Approved Basic #00-102169 BP	Plan: 022891 SFR w/finished basement - 199	2000
New	Approved Basic #00-101321 BP	Plan: 1632 Two Story SFR - 1997 UBC	2000
New	Approved Basic #99-116416 BP	Plan: 1567 Tri-Level SFR - 1997 UBC	2000
New	Approved Basic #00-101683 BP	Plan: 1730 SFR w/semi-finished lower floor	2000
New	Approved Basic #00-101321 BP	Plan: 1632 Two Story SFR - 1997 UBC	2000
New	Approved Basic #00-102169 BP	Plan: 022891 SFR w/finished basement - 199	2000
New	Approved Basic #99-116016 BP	Plan: 1450 Split Level SFR - 1997 UBC	2000
New	Approved Basic #00-102759 BP	Plan: 1452 Rambler Style SFR - 1997 UBC	2000
New	Approved Basic #99-116416 BP	Plan: 1567 Tri-Level SFR - 1997 UBC	2000
New	Approved Basic #00-102169 BP	Plan: 022891 SFR w/semi-finished basement	2000



Accessory Dwelling Units

Index # - File Name: 1.0022 - Single Family Dwellings Data\_Snohomish County.pdf

New	Approved Basic #00-102169 BP	Plan: 022891 SFR w/semi-finished basement	2000
New	Approved Basic #99-116416 BP	Plan: 1567 Tri-Level SFR - 1997 UBC	2000
New	Approved Basic #99-116016 BP	Plan: 1450 Split Level SFR - 1997 UBC	2000
New	Split Level SFR - 1997 UBC	Plan: 022891	2000
New	SFR w/finished lower floor - 1997 UBC	Plan: 1730	2000
New	SFR w/semi-finished lower floor - 1997 UBC	Plan: 1715	2000
New	Approved Basic #00-102169 BP	Plan: 022891 SFR w/finished basement - 199	2000
New	Approved Basic #99-116016 BP	Plan: 1450 Split Level SFR - 1997 UBC	2000
New	Approved Basic #00-102169 BP	Plan: 022891 SFR w/finished basement - 199	2000
New	Approved Basic #99-116016 BP	Plan: 1450 Split Level SFR - 1997 UBC	2000
New	Approved Basic #00-100528 BP	Plan: 1715 Split Level SFR w/semi-finished low	2000
New	Approved Basic #00-101683 BP	Plan: 1730 SFR w/semi-finished lower floor	2000
New	Approved Basic #99-116416 BP	Plan: 1567 Tri-Level SFR - 1997 UBC	2000
New	Approved Basic #00-101321 BP	Plan: 1632 Two Story SFR - 1997 UBC	2000
New	Approved Basic #00-100528 BP	Plan: 1715 Split Level SFR w/semi-finished lower f	2000
New	Two Story SFR - 1997 UBC	Plan: 1567	2000
New	Approved Basic #00-102759 BP	Plan: 1452 Rambler Style SFR - 1997 UBC	2000
New	Approved Basic #00-102169 BP	Plan: 022891 SFR w/finished basement - 199	2000
New	Approved Basic #99-104694BP	Plan: Georgetown Two Story SFR - 199	2000
New	Approved Basic #99-104609BP	Plan: The Logan Rambler Style SFR - 19	2000
New	Approved Basic #99-104694BP	Plan: Georgetown Two Story SFR - 199	2000
New	Approved Basic #99-104574BP	Plan: Kirkwood Rambler Style SFR	2000
New	Mid-Entry Style Sfr w/basement garage.	Bldrs. plan = Avalon-Mid Entry	2000
New	Approved Basic #99-104973BP	Plan: Cloverdale Rambler Style SFR - :	2000
New	Approved Basic #99-104973BP	Plan: Cloverdale Rambler Style SFR - :	2000
New	Approved Basic #99-104609BP	Plan: The Logan Rambler Style SFR - 19	2000
New	Approved Basic #99-104973BP	Plan: Cloverdale Rambler Style SFR - :	2000
New	Approved Basic #99-116397 BP	Mid-Entry Style Sfr w/basement garage. Bldrs. plan - Tri	2000
New	Approved Basic #99-104973BP	Plan: Cloverdale Rambler Style SFR - :	2000
New	Approved Basic #99-104574BP	Plan: Kirkwood Rambler Style SFR	2000
New	Approved Basic #98-110563BP	Plan 2146 Two Story SFR - 1997 UBC	2000
New	Approved Basic #99-109533 BP	Rambler w/attached 2-car garage....1997 UBC Plan No	2000
New	Approved Basic #98-110563BP	Plan 2146 Two Story SFR - 1997 UBC	2000
New	Approved Basic #99-109533 BP	Rambler w/attached 2-car garage....1997 UBC Plan No	2000
New	Approved Basic #99-109533 BP	Rambler w/attached 2-car garage....1997 UBC Plan No	2000
New	Approved Basic #98-110563BP	Plan 2146 Two Story SFR - 1997 UBC	2000
New	Approved Basic #99-116397 BP	Plan: Trisha - Mid-Entry Mid-Entry Style SFR w/fir	2000
New	Approved Basic #99-116397 BP	Plan: Trisha - Mid-Entry Mid-Entry Style SFR w/fir	2000
New	Approved Basic #99-116397 BP	Plan: Trisha - Mid-Entry Mid-Entry Style SFR w/fir	2000
New	Approved Basic #99-116397 BP	Plan: Trisha - Mid-Entry Mid-Entry Style SFR w/fir	2000
New	Approved Basic #99-116397 BP	Plan: Trisha - Mid-Entry Mid-Entry Style SFR w/fir	2000
New	Approved Basic #99-104694BP	Plan: Georgetown Two Story SFR - 1997 UBC	2000
New	Approved Basic #99-104694BP	Plan: Georgetown Two Story SFR - 1997 UBC	2000
New	Approved Basic #99-115502 BP	Plan: 99C-1860 Rambler Style SFR - 1997 UB	2000
New	Approved Basic #99-115502 BP	Plan: 99C-1860 Rambler Style SFR - 1997 UB	2000
New	Approved Basic #99-104694BP	Plan: Georgetown Two Story SFR - 1997 UBC	2000
New	Approved Basic #99-104694BP	Plan: Georgetown Two Story SFR - 1997 UBC	2000

Accessory Dwelling Units

Index # - File Name: 1.0022 - Single Family Dwellings Data\_Snohomish County.pdf

New	Approved Basic #99-116397 BP	Plan: Trisha - Mid-Entry	Mid-Entry Style SFR w/fir	2000
New	Approved Basic #99-116397 BP	Plan: Trisha - Mid-Entry	Mid-Entry Style SFR w/fir	2000
New	Approved Basic #99-116397 BP	Plan: Trisha - Mid-Entry	Mid-Entry Style SFR w/fir	2000
New	Approved Basic #99-116397 BP	Plan: Trisha - Mid-Entry	Mid-Entry Style SFR w/fir	2000
New	Approved Basic #99-116397 BP	Plan: Trisha - Mid-Entry	Mid-Entry Style SFR w/fir	2000
New	Approved Basic #99-116397 BP	Plan: Trisha - Mid-Entry	Mid-Entry Style SFR w/fir	2000
New	Approved Basic #99-116397 BP	Plan: Trisha - Mid-Entry	Mid-Entry Style SFR w/fir	2000
New	Approved Basic #99-116397 BP	Plan: Trisha - Mid-Entry	Mid-Entry Style SFR w/fir	2000
New	Approved Basic #99-116397 BP	Plan: Trisha - Mid-Entry	Mid-Entry Style SFR w/fir	2000
New	Approved Basic #99-116397 BP	Plan: Trisha - Mid-Entry	Mid-Entry Style SFR w/fir	2000
New	Approved Basic #99-116397 BP	Plan: Trisha - Mid-Entry	Mid-Entry Style SFR w/fir	2000
New	Approved Basic #99-116397 BP	Plan: Trisha - Mid-Entry	Mid-Entry Style SFR w/fir	2000
New	Approved Basic #99-116397 BP	Plan: Trisha - Mid-Entry	Mid-Entry Style SFR w/fir	2000
New	Approved Basic #99-116397 BP	Plan: Trisha - Mid-Entry	Mid-Entry Style SFR w/fir	2000
New	Approved Basic #99-116397 BP	Plan: Trisha - Mid-Entry	Mid-Entry Style SFR w/fir	2000
New	Approved Basic #99-116397 BP	Plan: Trisha - Mid-Entry	Mid-Entry Style SFR w/fir	2000
New	Approved Basic #99-116397 BP	Plan: Trisha - Mid-Entry	Mid-Entry Style SFR w/fir	2000
New	Approved Basic #99-116397 BP	Plan: Trisha - Mid-Entry	Mid-Entry Style SFR w/fir	2000
New	Approved Basic #99-116397 BP	Plan: Trisha - Mid-Entry	Mid-Entry Style SFR w/fir	2000
New	Approved Basic #99-116397 BP	Plan: Trisha - Mid-Entry	Mid-Entry Style SFR w/fir	2000
New	Approved Basic #99-116397 BP	Plan: Trisha - Mid-Entry	Mid-Entry Style SFR w/fir	2000
New	Approved Basic #99-116397 BP	Plan: Trisha - Mid-Entry	Mid-Entry Style SFR w/fir	2000
New	Approved Basic #99-110386 BP	Plan: Hawthorne	Rambler style SFF	2000
New	Approved Basic #99-109533 BP	Rambler w/attached 2-car garage....1997 UBC	Plan Nc	2000
New	Approved Basic #98-110563BP	Plan 2146	Two Story SFR - 1997 UBC	2000
New	Approved Basic #99-109533 BP	Rambler w/attached 2-car garage....1997 UBC	Plan Nc	2000
New	Approved Basic #99-104574BP	Plan: Kirkwood	Rambler Style SFR	2000
New	Approved Basic #99-104694BP	Plan: Georgetown	Two Story SFR - 199	2000
New	Approved Basic #99-104574BP	Plan: Kirkwood	Rambler Style SFR	2000
New	Approved Basic #99-104694BP	Plan: Georgetown	Two Story SFR - 199	2000
New	Approved Basic #99-104973BP	Plan: Cloverdale	Rambler Style SFR - :	2000
New	Approved Basic #99-116397 BP	Mid-Entry Style Sfr w/basement garage.	Bldrs. plan - Tri	2000
New	Approved Basic #99-104973BP	Plan: Cloverdale	Rambler Style SFR - :	2000
New	Approved Basic #99-104609BP	Plan: The Logan	Rambler Style SFR - 19	2000
New	Approved Basic #99-104694BP	Plan: Georgetown	Two Story SFR - 199	2000
New	Approved Basic #99-116397 BP	Mid-Entry Style Sfr w/basement garage.	Bldrs. plan - Tri	2000
New	Approved Basic #99-104694BP	Plan: Georgetown	Two Story SFR - 199	2000
New	Approved Basic #99-116397 BP	Mid-Entry Style Sfr w/basement garage.	Bldrs. plan - Tri	2000
New	Approved Basic #99-116397 BP	Mid-Entry Style Sfr w/basement garage.	Bldrs. plan = Tr	2000
New	Approved Basic #99-104694BP	Plan: Georgetown	Two Story SFR - 199	2000
New	Approved Basic #99-116397 BP	Mid-Entry Style Sfr w/basement garage.	Bldrs. plan - Tri	2000
New	Approved Basic #99-104973BP	Plan: Cloverdale	Rambler Style SFR - :	2000
New	Approved Basic #99-104694BP	Plan: Georgetown	Two Story SFR - 199	2000
New	Approved Basic #99-104609BP	Plan: The Logan	Rambler Style SFR - 19	2000
New	2 Story w/2 Car Approved Basic 00-101528BP			2000
New	Approved Basic #00-100563 BP	Plan #1927	Two Story SFR - 1997 UBC	2000
New	Approved Basic 00-100561 BP	Plan #2294 A	Two Story SFR - 1997 UBC	2000
New	Approved Basic #00-100563 BP	Plan #1927	Two Story SFR - 1997 UBC	2000
New	Approved Basic #00-100562 BP	Plan #294 B2F-0	Two Story SFR - 1997 UE	2000
New	Approved Basic 00-100561 BP	Plan #2294 A	Two Story SFR - 1997 UBC	2000

Accessory Dwelling Units

Index # - File Name: 1.0022 - Single Family Dwellings Data\_Snohomish County.pdf

New	Approved Basic #00-100563 BP	Plan #1927 Two Story SFR - 1997 UBC	2000
New	Approved Basic 00-100562 BP	Plan #2294 B2F-0 Two Story SFR - 1997 UE	2000
New	Approved Basic 00-100561 BP	Plan #2294 A Two Story SFR - 1997 UBC	2000
New	Approved Basic #00-100563 BP	Plan #1927 Two Story SFR - 1997 UBC	2000
New	Approved Basic #00-100563 BP	Plan #1927 Two Story SFR - 1997 UBC	2000
New	Approved Basic 00-100561 BP	Plan #294 A2F-0 Two Story SFR - 1997 UBC	2000
New	Approved Basic #00-100563 BP	Plan #1927 Two Story SFR - 1997 UBC	2000
New	2 story SFR with attached garage		2000
New	2-Story SFR w/-car garage.		2000
New	2-Story SFR w/2-car garage		2000
New	2 story SFR with attached garage		2000
New	Approved Basic #00-101129 BP	Builders Plan 1800 Two Story SFR - 1997 UBC	2000
New	Approved Basic #98-110504BP	Plan #2195 Split Level SFR - 1997 UBC	2000
New	Approved Basic #99-115504 BP	Plan #2195 Mid-Entry SFR - 1997 UB	2000
New	Approved Basic #99-115490 BP	Plan #1905 Two Story SFR - 1997 UBC	2000
New	Approved Basic #98-110504BP	Plan #2195 Split Level SFR - 1997 UBC	2000
New	Approved Basic #98-110504BP	Plan #2195 Split Level SFR - 1997 UBC	2000
New	1800 sf 2-story w/480 sf garage		2000
New	1126 s.f. w/748 s.f. finished basement & 2 car garage		2000
New	Approved Basic #00-102113-BP	Plan #1874 Mid-Entry Style SFR w/basement	2000
New	Approved Basic #00-102113-BP	Plan #1874 Mid-Entry Style SFR w/basement	2000
New	Approved Basic #00-102113-BP	Plan #1874 Mid-Entry Style SFR w/basement	2000
New	One-story SFR w/attached garage		2000
New	544 SF Living Quarters w/4016 Garage & unheated upstairs storage		2000
New	Approved Basic #00-100924 BP	Plan: 2405 Two Story SFR - 1997 UBC	2000
New	Approved Basic #99-115756 BP	Plan: 1884 Two Story SFR - 1997 UBC	2000
New	Approved Basic #00-100924 BP	Plan: 2405 Two Story SFR - 1997 UBC	2000
New	Approved Basic #99-101683BP	SFR w/finished basement - 1997 UBC	2000
New	Approved Basic #99-101683BP	SFR w/finished basement - 1997 UBC	2000
New	Approved Basic #99-116016 BP	Plan: 1450 Split Level SFR - 1997 UBC	2000
New	Approved Basic #99-101587BP	2 Story SFR/ 2 car garage	Plan # 2000
New	Approved Basic #98-109410BP	Plan: 1644 Split Level SFR - 1997 U	2000
New	Approved Basic #98-109408BP	Plan: 1705 slab SFR w/finished lower floor	2000
New	Approved Basic #98-109410 BP	Plan: 1644 Split Level SFR - 1997 UBC	2000
New	Approved Basic #99-101587BP	2 Story SFR/ 2 car garage	Plan # 2000
New	Approved Basic #98-109410BP	Plan: 1644 Split Level SFR - 1997 U	2000
New	Approved Basic #99-101345BP	Plan: 1352 SFR w/unfinished basement	2000
New	Approved Basic #98-109408BP	Plan: 1705 SFR w/unfinished lower	2000
New	Approved Basic #99-101587BP	2 Story SFR/ 2 car garage	Plan # 2000
New	Approved Basic #99-115502 BP	Plan: 99C-1860 Rambler Style SFR - 1	2000
New	Approved Basic #00-100924 BP	Plan: 2405 Two Story SFR - 1997 UBC	2000
New	Approved Basic #00-108319 BP	Plan: 1649 Two Story SFR - 1997 UBC	2000
New	Approved Basic #00-108317 BP	Plan: 2184/Hampton Two Story SFR - 1997 UBC	2000
New	1 story duplex w/attached garages		2000
New	1210 s.f. rambler w/2 car garage		2000
New	Approved Basic #00-101493-BP	Bldrs Plan # 1210 Rambler Style SFR w/att	2000
New	Approved Basic #00-101493-BP	Bldrs Plan # 1210 Rambler Style SFR w/att	2000



Accessory Dwelling Units

Index # - File Name: 1.0022 - Single Family Dwellings Data\_Snohomish County.pdf

New	Approved Basic #99-115502 BP	Plan: 99C-1860	Rambler Style SFR - 1	2000
New	Approved Basic #99-115502 BP	Plan: 99C-1860	Rambler Style SFR - 1	2000
New	Approved Basic #99-115502 BP	Plan: 99C-1860	Rambler Style SFR - 1	2000
New	Approved Basic #99-115502 BP	Plan: 99C-1860	Rambler Style SFR - 1	2000
New	Approved Basic #99-115502 BP	Plan: 99C-1860	Rambler Style SFR - 1	2000
New	Approved Basic #99-115502 BP	Plan: 99C-1860	Rambler Style SFR - 1	2000
New	Approved Basic #99-115502 BP	Plan: 99C-1860	Rambler Style SFR - 1	2000
New	Approved Basic #99-115502 BP	Plan: 99C-1860	Rambler Style SFR - 1	2000
New	Approved Basic #99-115502 BP	Plan: 99C-1860	Rambler Style SFR - 1	2000
New	Approved Basic #99-115502 BP	Plan: 99C-1860	Rambler Style SFR - 1	2000
New	Approved Basic #99-115502 BP	Plan: 99C-1860	Rambler Style SFR - 1	2000
New	Approved Basic #99-115502 BP	Plan: 99C-1860	Rambler Style SFR - 1	2000
New	One-story SFR			2000
New	Approved Basic #00-105791 BP	Plan: 4080 A	Two Story SFR - 1997 UBC	2000
New	Approved Basic #99-114666 BP		Plan: F932 Two Story SFR - 1997 U	2000
New	Two Story SFR - 1997 UBC	Plan: #949 B		2000
New	Approved Basic #99-114666 BP		Plan: F932 Two Story SFR - 1997 U	2000
New	2 Story SFR w/3 Car		#929C	2000
New	Two Story SFR - 1997 UBC	Plan: 949 G		2000
New	2-story SFR w/attached 4-car garage....1997 UBC			2000
New	Approved Basic #99-116037 BP	Plan: 865	Two Story SFR - 1997 UBC	2000
New	Approved Basic 00-101532 BP	Plan No. 511 M	Two Story SFR - 1997 UBC	2000
New	Two Story SFR - 1997 UBC	Plan: 4045 A		2000
New	Two Story SFR - 1997 UBC	Plan: #4080A		2000
New	Approved Basic #00-101281 BP	Plan: 949 A	Two Story SFR - 1997 UBC	2000
New	2 story SFR with attached garage			2000
New	Rambler w/3 Car			2000
New	Two Story SFR - 1997 UBC	Plan: #511B		2000
New	Approved Basic #99-116037 BP	Plan: 865	Two Story SFR - 1997 UBC	2000
New	Approved Basic #99-114928 BP	Plan: 929H	Two Story SFR - 1997 UBC	2000
New	2-story SFR w/attached 2-car garage....1997 UBC			2000
New	2-story SFR w/attached 2-car garage...1997 UBC			2000
New	Two-story SFR w/attached garage			2000
New	2-Story SFR w/attached garage			2000
New	Approved Basic #99-110072 BP	Plan: 2265	Two Story SFR - 1997 UBC	2000
New	Approved Basic #00-109943 BP	Plan: Duplex	Two Story Duplex	2000
New	2-story SFR w/unfinished daylight basement w/3-car garage....1997 UBC			2000
New	2 Story w/finished basement, 3 car garage			2000
New	Approved Basic #00-107838 BP	Ref. 00-103490	Plan: 2368-3 Two Story SFR - 1997	2000
New	Approved Basic #00-104403 BP	Plan: 2143	Two Story SFR w/unfinished base	2000
New	2343 sf 2-story w/1270 sf semi-finished basement, 386 sf garage, and 24 sf covered deck/porch			2000
New	Approved Basic #99-110071 BP	Plan: #2368	Two Story SFR - 1997 UBC	2000
New	Approved Basic #99-114387 BP	Plan: 2242	Two Story SFR - 1997 U	2000
New	2-story SFR w/unfinished basement....1997 UBC			2000
New	Approved Basic #00-105289 BP	Plan: 2586-2	Two Story SFR - 1997 UBC	2000
New	Approved Basic #99-114983 BP	Plan: 2445	Two Story SFR - 1997 UBC	2000
New	Approved Basic #99-110072 BP	Plan: 2265	Two Story SFR - 1997 UBC	2000

Accessory Dwelling Units

Index # - File Name: 1.0022 - Single Family Dwellings Data\_Snohomish County.pdf

New	Approved Basic #99-114387 BP	Plan: 2242 Two Story SFR - 1997 U	2000
New	Approved Basic #99-110071 BP	Plan: #2368 Two Story SFR - 1997 UBC	2000
New	Approved Basic #99-114983 BP	Plan: 2445 Two Story SFR - 1997 UBC	2000
New	Two-story SFR w/attached garage		2000
New	Approved Basic #99-114983 BP	Plan: 2445 Two Story SFR - 1997 UBC	2000
New	Approved Basic #00-107585 BP	Plan: #2343 Two Story SFR - 1997 UBC	2000
New	Semi finished Daylight Basement & 1-car garage....1997 UBC		2000
New	New two story SFR with attached two car garage.		2000
New	Approved Basic #98-110337BP	Plan #2146 E Two Story SFR with Att	2000
New	2 story sfr		2000
New	Two-story SFR w/attached garage		2000
New	Approved Basic #99-109632 BP	Elevation A Two Story SFR - 1997 UBC	2000
New	Approved Basic #99-113717 BP	Plan: #2002 Two Story SFR - 1997	2000
New	Approved Basic #99-109767 BP	Plan: 1256 (front-load) Split Level SFR	2000
New	Approved Basic #99-109767 BP	Plan: 1256 (front-load) Split Level SFR	2000
New	Approved Basic #99-113392 BP	Plan: 2220 Mid Entry SFR - 1997 UBC	2000
New	Approved Basic #99-113391BP	Plan: 1236 Mid Entry SFR - 1997 UBC	2000
New	Approved Basic #99-113717 BP	Plan: #2002 Two Story SFR - 1997	2000
New	Approved Basic #99-110072 BP	Plan: 2265 Two Story SFR - 1997 UBC	2000
New	Approved Basic #00-104405 BP	Plan: 2508-3 Two Story SFR w/unfinished bas	2000
New	Approved Basic #99-114983 BP	Plan: 2445 Two Story SFR - 1997 UBC	2000
New	Approved Basic #99-103777BP	Plan: 2415 A/3 Two Story SFR - 1997	2000
New	Two Story SFR - 1997 UBC	Plan: 2076	2000
New	Approved Basic #99-114401 BP	Plan: 2188 C Two Story SFR - 199	2000
New	Approved Basic #99-115756 BP	Plan: 1884 Two Story SFR - 1997 UBC	2000
New	Approved Basic #99-115756 BP	Plan: 1884 Two Story SFR - 1997 UBC	2000
New	Approved Basic #99-115755 BP	Two Story SFR - 1997 UBC	Plan: 227 2000
New	Two Story SFR - 1997 UBC	Plan: 2052	2000
New	Approved Basic #99-116088 BP	Plan: 2461 Two Story SFR - 1997 UBC	2000
New	Approved Basic #99-114387 BP	Plan: 2242 Two Story SFR - 1997 U	2000
New	Approved Basic #99-110072 BP	Plan: 2265 Two Story SFR - 1997 UBC	2000
New	Approved Basic #99-114983 BP	Plan: 2445 Two Story SFR - 1997 UBC	2000
New	Approved Basic #00-107587 BP	Plan #2422-2 Two Story SFR - 1997 UBC	2000
New	Approved Basic #99-103777BP	Plan: 2415 A/3 Two Story SFR - 1997	2000
New	Approved Basic #99-110072 BP	Plan: 2265 Two Story SFR - 1997 UBC	2000
New	Approved Basic #00-107585 BP	Plan: #2343 Two Story SFR - 1997 UBC	2000
New	2 Story w/ 3 Car		2000
New	Approved Basic #99-114387 BP	Plan: 2242 Two Story SFR - 1997 U	2000
New	Two-story SFR w/attached garage		2000
New	Approved Basic #99-116024BP	Plan: Avalon Two Story SFR - 1997 UBC	2000
New	Approved Basic #99-116026BP	Plan: Kensington Two Story SFR - 1997 UBC	2000
New	Approved Basic #99-116026BP	Plan: Kensington Two Story SFR - 1997 UBC	2000
New	Two-story SFR w/attached garage		2000
New	Approved Basic #99-115756 BP	Plan: 1884 Two Story SFR - 1997 UBC	2000
New	Two Story SFR - 1997 UBC	Plan: 2415	2000
New	Approved Basic #99-116088 BP	Plan: 2461 Two Story SFR - 1997 UBC	2000
New	Approved Basic #99-115755 BP	Two Story SFR - 1997 UBC	Plan: 227 2000

Accessory Dwelling Units

Index # - File Name: 1.0022 - Single Family Dwellings Data\_Snohomish County.pdf

New	Approved Basic #99-115755 BP	Two Story SFR - 1997 UBC	Plan: 227	2000
New	2 story sfr w/ 2 car garage			2000
New	Rambler Style SFR - 1997 UBC			2000
New	Two Story SFR - 1997 UBC	Plan: 2430		2000
New	2-story SFR w/attached 3-car garage & unfinished basement.....1997 UBC			2000
New	New two story with two car garage.			2000
New	Approved Basic #99-115230 BP	Plan: 1998	SFR w/finished basem	2000
New	Approved Basic 00-103947 BP	Two Story SFR - 1997 UBC	Plan:	2000
New	Approved Basic #99-115755 BP	Two Story SFR - 1997 UBC	Plan: 227	2000
New	Approved Basic #99-103777BP	Plan: 2415 A/3	Two Story SFR - 1997	2000
New	Approved Basic #99-116026BP	Plan: Kensington	Two Story SFR - 1997 UBC	2000
New	Approved Basic #00-103049 BP	Plan: 2076	Two Story SFR - 1997 UBC	2000
New	Approved Basic #98-107082BP	Plan 1715 side/load	Two Story SFR -	2000
New	Approved Basic #98-110337BP	Plan #2146 E	Two Story SFR with Att	2000
New	Approved Basic #00-103049 BP	Plan: 2076	Two Story SFR - 1997 UBC	2000
New	Approved Basic #98-108797BP	Plan 1715 side/load	Two Story SFR - 1997 U	2000
New	Two-story SFR w/attached garage			2000
New	27 X 65 Silver crest 1999			2000
New	Approved Basic #00-100912 BP	Plan: 1791	Two Story SFR - 1997 UBC	2000
New	Approved Basic #00-100912 BP	Plan: 1791	Two Story SFR - 1997 UBC	2000
New	Approved Basic #00-100912 BP	Plan: 1791	Two Story SFR - 1997 UBC	2000
New	Approved Basic #98-110348BP	Plan #2005	Two Story SFR - 1997 U	2000
New	Approved Basic #00-100912 BP	Plan: 1791	Two Story SFR - 1997 UBC	2000
New	1400 sf 2-story w/270 sf attached garage and 80 sf covered porch			2000
New	Approved Basic No. 00-106822 BP	Bldrs Plan: Kayak	Two Story SFR.....1997 UBC	2000
New	new two story with attached two car garage.			2000
New	Approved Basic #99-112583 BP	Plan 3025 A	Two Story SFR - 1997 UBC	2000
New	Approved Basic #99-112585 BP	Builders Plan 3105 D	Two Story SFR -	2000
New	Two Story SFR - 1997 UBC	Plan: 3210		2000
New	Approved Basic #99-112583 BP	Builders Plan 3025 A	Two Story SFR - 19	2000
New	Approved Basic #00-103323 BP	Plan: 2802	Two Story SFR - 1997 UBC	2000
New	Two Story SFR - 1997 UBC			2000
New	Two Story SFR - 1997 UBC	Plan: 3210		2000
New	Approved Basic #00-106076 BP	Plan: 2760	Two Story SFR -1997 UBC	2000
New	Approved Basic #00-103323 BP	Plan: 2802	Two Story SFR - 1997 UBC	2000
New	Two Story SFR - 1997 UBC			2000
New	Approved Basic #00- 107830 BP	Plan: 2802 front entry	Two Story SFR - 1997 U	2000
New	Approved Basic 00-106043 BP	PLAN #1827CS/2	Mid-entry SFR - 1997 UBC	2000
New	SFR w/finished lower floor - 1997 UBC			2000
New	Approved Basic 00-106043 BP	PLAN #1827CS/2	Mid-entry SFR - 1997 UBC	2000
New	Approved Basic #00-100575 BP	Plan: 99-20	Two Story SFR - 1997 UBC	2000
New	Approved Basic #00-101467 BP	Plan: 99-23	Two Story SFR - 1997 UBC	2000
New	Approved Basic #00-101465 BP	Plan: 99-25	Rambler Style SFR - 1997 UBC	2000
New	Approved Basic #00-101256 BP	Plan: 99-24	Two Story SFR - 1997 UBC	2000
New	Approved Basic #00-101467 BP	Plan: 99-23	Two Story SFR - 1997 UBC	2000
New	Approved Basic #00-100570 BP	Plan: 99-22	Two Story SFR - 1997 UBC	2000
New	Approved Basic #00-100575 BP	Plan: 99-20	Two Story SFR - 1997 UBC	2000

Accessory Dwelling Units

Index # - File Name: 1.0022 - Single Family Dwellings Data\_Snohomish County.pdf

New	Approved Basic #00-101256 BP	Plan: 99-24 Two Story SFR - 1997 UBC	2000
New	Approved Basic #00-101252 BP	Plan: 99-21 Two Story SFR - 1997 UBC	2000
New	Approved Basic #00-100575 BP	Plan: 99-20 Two Story SFR - 1997 UBC	2000
New	Approved Basic #00-101256 BP	Plan: 99-24 Two Story SFR - 1997 UBC	2000
New	Approved Basic #00-100570 BP	Plan: 99-22 Two Story SFR - 1997 UBC	2000
New	Approved Basic #00-101467 BP	Plan: 99-23 Two Story SFR - 1997 UBC	2000
New	Approved Basic #00-101256 BP	Plan: 99-24 Two Story SFR - 1997 UBC	2000
New	Approved Basic #00-101252 BP	Plan: 99-21 Two Story SFR - 1997 UBC	2000
New	Approved Basic #00-100570 BP	Plan: 99-22 Two Story SFR - 1997 UBC	2000
New	Approved Basic #00-100575 BP	Plan: 99-20 Two Story SFR - 1997 UBC	2000
New	Approved Basic #00-101256 BP	Plan: 99-24 Two Story SFR - 1997 UBC	2000
New	Approved Basic #00-101252 BP	Plan: 99-21 Two Story SFR - 1997 UBC	2000
New	Approved Basic #00-101467 BP	Plan: 99-23 Two Story SFR - 1997 UBC	2000
New	Approved Basic #00-101252 BP	Plan: 99-21 Two Story SFR - 1997 UBC	2000
New	Approved Basic #00-101256 BP	Plan: 99-24 Two Story SFR - 1997 UBC	2000
New	Approved Basic #00-100570 BP	Plan: 99-22 Two Story SFR - 1997 UBC	2000
New	Two Story SFR - 1997 UBC	Plan: 99-21	2000
New	Two Story SFR - 1997 UBC	Plan: WAS 99-24	2000
New	Approved Basic #98-150505 BP	Plan: 1771 Two Story SFR - 1997 UBC	2000
New	Rambler Style SFR - 1997 UBC	Plan: WAS 99-25	2000
New	Approved Basic #00-100570 BP	Plan: 99-22 Two Story SFR - 1997 UBC	2000
New	Approved Basic #00-101252 BP	Plan: 99-21 Two Story SFR - 1997 UBC	2000
New	Approved Basic #00-101256 BP	Plan: 99-24 Two Story SFR - 1997 UBC	2000
New	Approved Basic #00-100570 BP	Plan: 99-22 Two Story SFR - 1997 UBC	2000
New	Two Story SFR - 1997 UBC	Plan: WAS 99-23	2000
New	Approved Basic #00-101252 BP	Plan: 99-21 Two Story SFR - 1997 UBC	2000
New	Approved Basic #00-101467 BP	Plan: 99-23 Two Story SFR - 1997 UBC	2000
New	Approved Basic #00-101252 BP	Plan: 99-21 Two Story SFR - 1997 UBC	2000
New	Approved Basic #00-101465 BP	Plan: 99-25 Rambler Style SFR - 1997 UBC	2000
New	Two Story SFR - 1997 UBC	Plan: 99-20	2000
New	Approved Basic #00-100570 BP	Plan: 99-22 Two Story SFR - 1997 UBC	2000
New	Approved Basic #00-101467 BP	Plan: 99-23 Two Story SFR - 1997 UBC	2000
New	Approved Basic #00-100575 BP	Plan: 99-20 Two Story SFR - 1997 UBC	2000
New	Approved Basic #98-110504BP	Plan #2195 Split Level SFR - 1997 UBC	2000
New	Approved Basic #00-102986 BP	Plan: #2320 Two Story SFR - 1997 UBC	2000
New	2130 sf 2-story		2000
New	2-story SFR w/attached 2-car garage....1997 UBC		2000
New	Two-story SFR w/attached garage		2000
New	14 x 70 (1978) Fleetwood		2000
New	Approved Basic #99-112379 BP	Plan #2417 Two Story SFR - 1997 UBC	2000
New	Two-story SFR w/attached garage		2000
New	2 story SFR with attached garage		2000
New	Approved Basic #99-113793 BP	Plan: 2203 Two Story SFR - 1997 U	2000
New	Approved Basic #00-103198 BP	Plan: 2251 Two Story SFR - 1997 UBC	2000
New	Approved Basic #99-115762 BP	Builders Plan 2005 Two-story SFR - 1997 U	2000
New	1988 14 x 50 Glenwood (Guest House)		2000
New	2 story SFR with covered porch		2000



Accessory Dwelling Units

Index # - File Name: 1.0022 - Single Family Dwellings Data\_Snohomish County.pdf

New	40 x 66 2000 Fleetwood		2000
New	Approved Basic #99-112141 BP	Bldrs. Plan: Mt Raineer Two Story SFR - 1997 UE	2000
New	2 story sfr w/2 car garage		2000
New	Two-story SFR w/attached garage		2000
New	Approved Basic 99-101299BP	Plan: #10 Mid-Entry With 2 Car - 1997 UI	2000
New	Approved Basic #99-109597 BP Two Story SFR - 1997 UBC	Plan:	2000
New	2 story sfr w/3 car garage		2000
New	Approved Basic #98-110722BP Two Story SFR - 1997 UBC	Plan #22	2000
New	Approved Basic #00-104827 BP	Plan: 2551 Two Story SFR - 1997 UBC	2000
New	2-story SFR.....1997 UBC		2000
New	Two Story SFR - 1997 UBC	Plan: 1927	2000
New	Approved Basic #00-100666 BP	Plan: 9905 - wood floor Mid-entry SFR w/finishe	2000
New	2 story SFR with attached garage		2000
New	Approved Basic #00-100666 BP	Plan: 9905 - wood floor Mid-entry SFR w/finishe	2000
New	Approved Basic 00 104401 BP	Builders Plan 6410 Two-story SFR w/attache	2000
New	Approved Basic #00-100721 BP	Plan 9916 Rambler Style SFR - 1997 UBC	2000
New	2 story Duplex with attached garages ---- 1997 UBC		2000
New	1728 s.f. rambler w/2 car garage		2000
New	Approved Basic 00 104401 BP	Builders Plan 6410 Two-story SFR w/attached ga	2000
New	Approved Basic #00-100666 BP	Plan: 9905 - wood floor Mid-entry SFR w	2000
New	2 story sfr		2000
New	28x56 (1999) Fleetwood		2000
New	2384 sf 2-story		2000
New	28.5 x 68 Marlette		2000
New	27x66, 2000 Golden west		2000
New	2274 sf rambler w/1064 sf garage and 530 sf covered deck/porch		2000
New	14 x 56 1978 Fleetwood		2000
New	Two Story SFR - 1997 UBC		2000
New	Two Story SFR with Attached Garage		2000
New	1986 Capma Capital Cape 66 x 14		2000
New	Two-story SFR w/attached garage		2000
New	Approved Basic #99-109776 BP	Plan: 2397 w/bonus Two Story SFR -	2000
New	2 story sfr with 3 car garage		2000
New	Approved Basic #99-104638BP	Plan: 2274 Rambler Style SFR - 1997	2000
New	Two Story SFR with Attached Garage		2000
New	Cabin Style SFR		2000
New	40x48, 1999 Skyline		2000
New	40x64, 1999 Oakwood		2000
New	4510.5 s.f. duplex with 5 car garage		2000
New	Approved Basic #99-114133 BP	Plan #2163BA Two Story SFR w/garag	2000
New	Two Story SFR w/finished basement - 1997 UBC	Bldrs Plan 2263-D	2000
New	Approved Basic #00-104827 BP	Plan: 2551 Two Story SFR - 1997 UBC	2000
New	Approved Basic #98-107594BP	Plan #2211-B Two Story SFR w/	2000
New	2 story sfr w/2 car garage		2000
New	One-story SFR w/finished basement & attached garage	Builders Plan 1215A	2000
New	Approved Basic #98-107594BP	Plan #2211-B Two Story SFR w/	2000
New	2551 sf 2-story w/624 sf garage and 100 sf covered deck/porch		2000

Accessory Dwelling Units

Index # - File Name: 1.0022 - Single Family Dwellings Data\_Snohomish County.pdf

New	Approved Basic #99-114460 BP	Plan: #2080	Two Story SFR - 1997 UB	2000
New	2-story SFR.....1997 UBC			2000
New	Two-story SFR w/attached garage			2000
New	Approved Basic #98-110003BP	Plan: Wycliffe Crest	Two-story SFR w/att	2000
New	Approved Basic #99-111773 BP	Builders Plan #1800	Two Story SFR - 1997 UBC	2000
New	1887 sf 2-story w/470sf garage and 40 sf covered deck/porch and 120 sf open deck			2000
New	Approved Basic #98-116267BP	Plan: North Carolina w/den	Two Story SFR - 1997 UBC	2000
New	1612 sf rambler w/1612 sf unfinished basement and 457 sf garage w/28 sf covered deck/porch			2000
New	Approved Basic #99-113529 BP	Plan: 1927	Two Story SFR - 1997 UBC	2000
New	Approved Basic #99-113529 BP	Plan: 1927	Two Story SFR - 1997 UBC	2000
New	Approved Basic #98-151027BP	Plan: South Carolina w/den	Two Story SFR - 1997 UB	2000
New	Approved Basic #99-112039 BP	Plan: 2002	Two Story SFR - 1997 UBC	2000
New	Approved Basic #99-111773 BP	Builders Plan #1800	Two Story SFR - 1997 UBC	2000
New	2265 sf 2-story w/428 sf garage and 208 sf covered deck/porch and 170sf open patio			2000
New	2250 sf 2-story w/470 sf garage, 144 sf covered deck/porch and 180 sf open patio			2000
New	Approved Basic #99-111773 BP	Builders Plan #1800	Two Story SFR - 1997 UBC	2000
New	Two-story SFR w/basement garage			2000
New	Approved Basic No. 00-107382 BP	Bldr Plan: 2188 Front 2 Car	2-story style SFR....1997 UBC	2000
New	2 story sfr with 3 car garage. STOP WORK POSTED BY GERRY SCHELBRACK, 10/27/00.			2000
New	2 story sfr with 2 car garage			2000
New	2 story sfr w/3 car garage			2000
New	Approved Basic #98-116918BP	Plan: South Carolina w/no den.	Two Story SFR	2000
New	Approved Basic #99-111773 BP	Builders Plan #1800	Two Story SFR - 1997 UBC	2000
New	2886 s.f. rambler with 3 car garage			2000
New	2-story SFR w/attached 3-car garage....1997 UBC			2000
New	28 x 54 Fleetwood 1985			2000
New	490 sf unfinished basement w/1691 sf 2-story, 541 sf garage and 28 sf covered deck/porch			2000
New	2-story SFR w/attached 3-car garage....1997 UBC			2000
New	Approved Basic #98-108977BP	Plan #1344 R	Two Story SFR - 1997 UB	2000
New	Two Story SFR with Attached Garage			2000
New	2382 sf rambler w/753 sf garage, 105 sf covered deck/porch and 160 sf open deck			2000
New	One-story SFR w/attached garage			2000
New	One-story SFR w/attached garage			2000
New	2 Story w/3 Car			2000
New	Approved Basic #00-107353 BP	Two Story style SFR.....1997 UBC		2000
New	14 X 70 1985 Fleetwood			2000
New	40 X 66 Marlette 2000			2000
New	Rambler style SFR w/loft.....1997 UBC			2000
New	26 6 x66 2000 Winfield			2000
New	Approved Basic #00-109309 BP	Plan: 1938/Chelsea (side load)	Two Story SFR - 1997 UBC	2000
New	2-Story SFR w/attached gar	Plan: 1868/Brookside		2000
New	Approved Basic #00-107241 BP	Plan: 1988	Two Story SFR - 1997 UBC	2000
New	Two Story SFR - 1997 UBC	Plan: 1971 Avalon		2000
New	Approved Basic #00-109315 BP	Plan: Brookside	Two Story SFR....1997 UBC	2000
New	Approved Basic #00-109314 BP	Plan: 1755/Parkside	Two Story SFR....1997 UBC	2000
New	Approved Basic #00-108299 BP	Plan: 1922/Covington	Two Story SF	2000
New	Two Story SFR - 1997 UBC	Plan: 1901/Waterbrooke		2000

Accessory Dwelling Units

Index # - File Name: 1.0022 - Single Family Dwellings Data\_Snohomish County.pdf

New	Approved Basic #00-109315 BP	Plan: Brookside Two Story SFR....1997 UBC	2000
New	Approved Basic #00-109316 BP	Plan: Waterbrooke Two Story SFR - 1997 U	2000
New	Approved Basic #00-109312 BP	Plan: Avalon Two Story SFR - 1997 UBC	2000
New	1796 s.f. rambler w/2 car garage		2000
New	1796 s.f. rambler w/2 car garage		2000
New	Approved Basic #00-108299 BP	Plan: 1922/Covington Two Story SF	2000
New	Approved Basic #00-107241 BP	Plan: 1988 Two Story SFR - 1997 UBC	2000
New	Approved Basic #00-108301 BP	Plan: 1938/Chelsea Two Story SFR - 1997 UBC	2000
New	Approved Basic #00-108301 BP	Plan: 1938/Chelsea Two Story SFR - 1997 UBC	2000
New	28x48 1984 Kentwood		2000
New	Approved Basic #99-109776 BP	Plan: 2397 w/bonus Two Story SFR - 1997 UBC	2000
New	Approved Basic #99-109776 BP	Plan: 2397 w/bonus Two Story SFR - 1997 UBC	2000
New	Approved Basic #99-104638BP	Plan: 2274 Rambler Style SFR - 1997 UBC OPTI	2000
New	Approved Basic #99-109776 BP	Plan: 2397 w/bonus Two Story SFR - 1997 UBC	2000
New	Approved Basic #99-104638BP	Plan: 2274 Rambler Style SFR - 1997 UBC OPTIC	2000
New	Approved Basic 99105003 BP	Builders Plan 9410-A Two-story SFR w/	2000
New	Approved Basic 99105003 BP	Builders Plan 9410-A Two-story SFR w/	2000
New	Approved Basic #00-100666 BP	Plan: 9905 - wood floor Mid-entry SFR w/finishe	2000
New	Approved Basic #00-100721 BP	Plan 9916 Rambler Style SFR - 1997 UBC	2000
New	Approved Basic #00-100666 BP	Plan: 9905 - wood floor Mid-entry SFR w/finishe	2000
New	Approved Basic #00-100721 BP	Plan 9916 Rambler Style SFR - 1997 UBC	2000
New	Approved Basic #00-100666 BP	Plan: 9905 - wood floor Mid-entry SFR w/finishe	2000
New	Approved Basic 00 104401 BP	Builders Plan 6410 Two-story SFR w/attached ga	2000
New	Rambler style SFR.....1997 UBC		2000
New	Approved Basic #00-110135	Plan# M1528A2S-1 Two Story SFR - 1997 UBC	2000
New	2-story SFR.....1997 UBC	Bldrs Plan No. 1725	2000
New	2 Story w/ 2 Car Garage		2000
New	Two Story SFR - 1997 UBC		2000
New	Approved Basic #00-110075 BP	Bldrs Plan No. 1676 Two Story Style SFR.....1997 U	2000
New	Two Story SFR - 1997 UBC		2000
New	Approved Basic #00-110075 BP	Bldrs Plan No. 1676 Two Story - SFR.....1997 UBC	2000
New	Approved Basic #00-109738 BP	Plan: 1725 Gable Two Story SFR - 1997 UBC	2000
New	Approved Basic #00-109738 BP	Plan: 1725 Two Story SFR - 1997 UBC	2000
New	Approved Basic #00-110075 BP	Bldrs Plan No. 1676 Two Story - SFR.....1997 UBC	2000
New	88 x 62 two-story SFR with attached garage		2000
New	Approved Basic #00-106932 BP	Plan: 394 (2) A Tri-Level Style SFR.....1997 UB	2000
New	Approved Basic #00-106931 BP	Plan: 394 (2) B Tri-Level Style SFR.....1997 UBC	2000
New	Approved Basic #00-106932 BP	Plan: 394 (2) A Tri-Level Style SFR.....1997 UB	2000
New	28 x 40 - 2000 - Marlette		2000
New	Approved Basic #00-108547 BP	Plan: 2127 side garage Two Story SFR - 1997 UB	2000
New	Approved Basic #00-108547 BP	Plan: 2127 side garage Two Story SFR - 1997 UB	2000
New	Approved Basic #98-109315BP	Split SFR w/finished lower floor - 1997 UBC	2000
New	Approved Basic #00-108550 BP	Plan: 2294 A Two Story SFR - 1997 UBC	2000
New	Approved Basic #00-110392 BP	Builders Plan 2407 Daylight One-story SFR w/basemen	2000
New	Approved Basic #00-108550 BP	Plan: 2294 A Two Story SFR - 1997 UBC	2000
New	Approved Basic #00-110392 BP	Builders Plan 2407 Daylight One-story SFR w/baseme	2000
New	Approved Basic #00-108547 BP	Plan: 2127 side garage Two Story SFR - 1997 UB	2000

Accessory Dwelling Units

Index # - File Name: 1.0022 - Single Family Dwellings Data\_Snohomish County.pdf

New	Approved Basic #00-108547 BP	Plan: 2127 side garage	Two Story SFR - 1997 UBC	2000
New	Two Story SFR - 1997 UBC	Plan: 1969/2		2000
New	Approved Basic #00-108548 BP	Plan: 2127 front garage	Two Story SFR - 1997 UE	2000
New	Two Story SFR - 1997 UBC	Plan: 2127		2000
New	SFR w/finished lower floor - 1997 UBC			2000
New	Two Story SFR - 1997 UBC	Plan: 2294		2000
New	One-story SFR w/finished basement	Builders Plan 2407		2000
New	Approved Basic #98-109303BP	Split SFR w/finished lower floor - 1997 UBC		2000
New	Approved Basic #98-109315BP	Split SFR w/finished lower floor - 1997 UBC		2000
New	Approved Basic #00-108549 BP	Plan: 1871 w/basement	Two Story SFR w/finished b	2000
New	1188 s.f. w/1050 finished basement & 400 s.f. garage			2000
New	Approved Basic #00-108549 BP	Plan: 1871 w/basement	Two Story SFR w/finished b	2000
New	Approved Basic #00-108549 BP	Plan: 1871 w/basement	Two Story SFR w/finished b	2000
New	Approved Basic #00-108549 BP	Plan: 1871 w/basement	Two Story SFR w/finished b	2000
New	Two Story SFR w/finished basement - 1997	Plan: 1871 basement		2000
New	Two Story SFR w/finished basement - 1997	Plan: 2127 Basement		2000
New	Approved Basic #00-108551 BP	Plan: 2127 w/basement	Two Story SFR w/finishec	2000
New	Approved Basic #00-108423 BP	Plan: 394(3)B	Two Story SFR w/finished lc	2000
New	Approved Basic #00-106933 BP	Plan: 394 (2) C	Tri-Level Style SFR.....1997 UBC	2000
New	Approved Basic #00-108422 BP	Plan: 394(3)A	Two Story SFR w/finished lc	2000
New	Approved Basic #00-106932 BP	Plan: 394 (2) A	Tri-Level Style SFR.....1997 UB	2000
New	Approved Basic 98-110279BP		Rambler Style SFR with attached garage --	2000
New	Approved Basic 98-110279BP		Rambler Style SFR with attached garage --	2000
New	1 Story w/ deck			2000
New	Approved Basic #00-106931 BP	Plan: 394 (2) B	Tri-Level Style SFR.....1997 UBC	2000
New	Approved Basic #00-110312 BP	Plan: #2580	Two Story SFR - 1997 UBC	2000
New	Approved Basic #00-110306 BP	Plan #2755	Two-story SFR w/attached	2000
New	Approved Basic #00-110348 BP	Plan: 2241 C/3	Two Story SFR - 1997 UBC	2000
New	New 2 story SFR w/ attached 3 car garage			2000
New	New 2 story sfr w/ attached 3 car garage			2000
New	Two-story SFR w/attached garage			2000
New	Approved Basic #99-101718BP	Plan #1056	Rambler Style SFR - 1997 UBC	2000
New	Approved Basic #99-103817BP	Plan: 1200 (Floor Framing Change)	Rambler Style SFR	2000
New	Approved Basic 99-115181BP	Plan: 1199	Rambler Style SFR - 1997 U	2000
New	Approved Basic #99-103817BP	Plan: 1200 (Floor Framing Change)	Rambler Style SFR -	2000
New	SFR with Semi-Finished Basement and Attached Garage			2000
New	One-story SFR with semi-finished basement & attached garage.			2000
New	One-story SFR with semi-finished BP basement & attached garage			2000
New	SFR with Semi-Finished Basement and Attached Garage			2000
New	2 story SFR with attached garage			2000
New	2 story SFR with attached garage			2000
New	1080 s.f. w/635 s.f. semi-finished basement			2000
New	1080 s.f. w/635 s.f. semi-finished basement			2000
New	SFR with lower floor semi finished w/ 2 car garage			2000
New	Approved Basic #98-150974BP	Plan: Rambler w/bonus	Rambler Style SFR w/bon	2000
New	Approved Basic #98-150974BP	Plan: Rambler w/bonus	Rambler Style SFR w/bonus t	2000
New	Approved Basic #98-150628BP	Plan: 50 er	Two Story SFR - 1997 UBC	2000

Accessory Dwelling Units

Index # - File Name: 1.0022 - Single Family Dwellings Data\_Snohomish County.pdf

New	2 story sfr w/2 car garage		2000
New	SFR with 568 Sq Ft Finished Basement and Attached Garage - 1997 UBC		2000
New	Approved Basic #00-109571 BP	Plan: 1477 Two Story SFR - 1997 UBC	2000
New	Approved Basic #00-109571 BP	Plan: 1477 Two Story SFR - 1997 UBC	2000
New	Approved Basic #00-109567 BP	Plan: 1650 Split level SFR w/finished lower	2000
New	Approved Basic #00-109567 BP	Plan: 1650 Split level SFR w/finished lower	2000
New	Approved Basic #00-109567 BP	Plan: 1650 Split level SFR w/finished lower	2000
New	Approved Basic #00-109571 BP	Plan: 1477 Two Story SFR - 1997 UBC	2000
New	Two Story SFR - 1997 UBC	Plan: 1832 0 Lot Line S	2000
New	Two Story SFR - 1997 UBC	Plan: 1790	2000
New	Approved Basic #00-106758 BP	Plan: E Two Story SFR - 1997 UBC	2000
New	Approved Basic #00-106758 BP	Plan: E Two Story SFR - 1997 UBC	2000
New	Approved Basic #99-116024BP	Plan: Avalon Two Story SFR - 1997 UBC	2000
New	Approved Basic #00-103949 BP	Plan: 2415 Two Story SFR - 1997 UBC	2000
New	Approved Basic #00-103949 BP	Plan: 2415 Two Story SFR - 1997 UBC	2000
New	Approved Basic #00-106097 BP	Plan: 2415 Two Story SFR - 1997 UBC	2000
New	Approved Basic #00-106010 BP	Plan: 2342 Two Story SFR - 1997 UBC	2000
New	Approved Basic #99-115755 BP Two Story SFR - 1997 UBC	Plan: 227	2000
New	Approved Basic #99-116024BP	Plan: Avalon Two Story SFR - 1997 UBC	2000
New	Approved Basic #99-115756 BP	Plan: 1884 Two Story SFR - 1997 UBC	2000
New	Single story SFR with attached garage ...1997 UBC		2000
New	Approved Basic #00-102507 BP	Plan: 1290 Two Story SFR - 1997 UBC	2000
New	Two-story SFR w/partially finished basement		2000
New	Approved Basic #99-103574BP	Plan: 4002 Two Story SFR - 1997 UB	2000
New	Approved Basic #99-103342BP	Plan: 5222 Two Story SFR - 199	2000
New	Approved Basic #99-103347BP	Plan: 4001 Two Story SFR - 199	2000
New	Approved Basic #99-109707 BP	Plan: 5124 Two Story SFR - 1997 UBC	2000
New	2 Story w/3 Car		2000
New	2556 sf 2-story w/830 sf unfinished basement, 876 sf garage, 30 sf covered deck/porch, and 168		2000
New	Approved Basic #99-103349BP	Plan: 5318 Two Story SFR - 199	2000
New	Approved Basic #99-103832BP	Plan: 4003 Two Story SFR - 199	2000
New	Approved Basic #99-101211BP Two Story SFR - 1997 UBC	Plan: 5023/5123 w	2000
New	Approved Basic #99-103342BP	Plan: 5222 Two Story SFR - 199	2000
New	Approved Basic #99-103349BP	Plan: 5318 Two Story SFR - 199	2000
New	Approved Basic #99-114154 BP	Plan: 5122 w/o bonus Two Story SFR	2000
New	Approved Basic #00-104042 BP	Plan: 4105 B Two Story SFR - 1997 UBC	2000
New	Approved Basic #99-101211BP Two Story SFR - 1997 UBC	Plan: 5023/5123 w	2000
New	Approved Basic #99-103342BP	Plan: 5222 Two Story SFR - 199	2000
New	Approved Basic #99-101211BP Two Story SFR - 1997 UBC	Plan: 5023/5123 w	2000
New	Approved Basic #99-103349BP	Plan: 5318 Two Story SFR - 199	2000
New	Approved Basic #99-103349BP	Plan: 5318 Two Story SFR - 199	2000
New	Approved Basic #99-101214BP Two Storyy SFR - 1997 UBC	Plan: 5223/5323 w/k	2000
New	2556 sf 2-story w/876 sf garage		2000
New	Approved Basic #00-107977 BP	Plan: 1980 Rambler Style SFR - 1997 UBC	2000
New	Approved Basic #99-103574BP	Plan: 4002 Two Story SFR - 1997 UB	2000
New	Approved Basic #99-103347BP	Plan: 4001 Two Story SFR - 199	2000
New	Approved Basic #99-101211BP Two Story SFR - 1997 UBC	Plan:	2000

Accessory Dwelling Units

Index # - File Name: 1.0022 - Single Family Dwellings Data\_Snohomish County.pdf

New	Approved Basic #99-103347BP	Plan: 4001 Two Story SFR - 1997	2000
New	Approved Basic #99-103574BP	Plan: 4002 Two Story SFR - 1997 UB	2000
New	Approved Basic #99-101211BP Two Story SFR - 1997 UBC	Plan: 5023/5123 w	2000
New	Approved Basic #99-103574BP	Plan: 4002 Two Story SFR - 1997 UB	2000
New	Approved Basic #99-103347BP	Plan: 4001 Two Story SFR - 1997	2000
New	Approved Basic #00-104044 BP	Plan: 4005 B Two Story SFR - 1997 UBC	2000
New	Approved Basic #99-101214BP Two Story SFR - 1997 UBC	Plan: 5223/5323 w/t	2000
New	Approved Basic #99-114271 BP	Plan: 4202 B/C Two Story SFR -	2000
New	Approved Basic #99-101211BP Two Story SFR - 1997 UBC	Plan: 5023/5123 w	2000
New	Approved Basic #99-103342BP	Plan: 5222 Two Story SFR - 1997	2000
New	Approved Basic #99-103574BP	Plan: 4002 Two Story SFR - 1997 UB	2000
New	Approved Basic #99-103349BP	Plan: 5318 Two Story SFR - 1997	2000
New	Two Story SFR - 1997 UBC		2000
New	Two Story SFR - 1997 UBC		2000
New	Two Story SFR - 1997 UBC		2000
New	Approved Basic #99-112600 BP Two Story SFR - 1997 UBC	Plan: RH 14	2000
New	2 story sfr w/2 car garage		2000
New	Approved Basic #99 103025 BP	Plan: 1450 S SFR w/finished baserr	2000
New	Approved Basic #99-110537 BP	Plan: 2576 Two Story SFR - 1997 UBC OP	2000
New	Approved Basic #98-110563BP	Plan 2146 Two Story SFR - 1997 UBC	2000
New	Approved Basic #99-109533 BP Rambler w/attached 2-car garage....1997 UBC	Plan No	2000
New	Approved Basic #99-111975 BP	Plan: 1533 Two Story SFR - 1997	2000
New	Rambler Style SFR - 1997 UBC		2000
New	Approved Basic #00-102507 BP	Plan: 1290 Two Story SFR - 1997 UBC	2000
New	Approved Basic #00-103206 BP	Plan: 1528 Rambler Style SFR - 1997 UBC	2000
New	Approved Basic #99-111975 BP	Plan: 1533 Two Story SFR - 1997	2000
New	Approved Basic No. 00-105331 BP	Bldrs Plan No. 1932 2-story SFR.....1997 U	2000
New	Approved Basic #99-111975 BP	Plan: 1533 Two Story SFR - 1997	2000
New	Approved Basic #00-101627 BP	Plan: 1221 A Two Story SFR - 1997 UBC	2000
New	Approved Basic No. 00-105333 BP	Bldrs Plan No. 1502 Rambler style SFR.....19	2000
New	1502 sf rambler w/680 sf garage and 104 sf covered deck/porch		2000
New	Approved Basic #00-103875 BP	Plan: 1739 Rambler style SFR....1997 UBC	2000
New	Approved Basic No. 00-105333 BP	Plan: 1502 Rambler Style SFR - 1997 UBC	2000
New	Approved Basic No. 00-105335 BP	Plan #2171 Two Story SFR - 1997 UBC	2000
New	Approved Basic #00-101627 BP	Plan: 1221 A Two Story SFR - 1997 UBC	2000
New	Approved Basic #00-105333 BP	Plan: 1502 Rambler Style SFR - 1997 UBC	2000
New	Approved Basic #99-111975 BP	Plan: 1533 Two Story SFR - 1997 UBC	2000
New	Approved Basic #99-111975 BP	Plan: 1533 Two Story SFR - 1997	2000
New	Approved Basic #00-102507 BP	Plan: 1290 Two Story SFR - 1997 UBC	2000
New	Approved Basic #00-103206 BP	Plan: 1528 Rambler Style SFR - 1997 UBC	2000
New	Approved Basic #00-103052-BP	Plan:1621-3C Two Story SFR - 1997 UBC	2000
New	Approved Basic No. 00-105335 BP	Bldrs Plan No. 2171 2-Story SFR.....1997 U	2000
New	Approved Basic No. 00-105335 BP	Bldrs Plan No. 2171 2-Story SFR.....1997 UI	2000
New	Approved Basic #00-103875 BP	Plan: 1739 Rambler w/attached 2 or 3 car garage..	2000
New	Approved Basic #00-103052 BP	Plan: 1621C 3/car Two Story SFR - 1997 U	2000
New	1739 s.f. rambler with 2 car garage		2000

Accessory Dwelling Units

Index # - File Name: 1.0022 - Single Family Dwellings Data\_Snohomish County.pdf

New	Two Story SFR - 1997 UBC	Plan: 1932	2000
New	Two Story SFR - 1997 UBC	Plan: 1290	2000
New	Rambler w/attached 2-car garage....1997 UBC		2000
New	2 story sfr w/3 car garage		2000
New	One-story SFR w/attached garage		2000
New	Approved Basic #99-113971 BP	Plan: 1315 Split Level SFR - 1997 UBC	2000
New	Approved Basic #99-113971 BP	Plan: 1315 Split Level SFR - 1997 UBC	2000
New	Rambler w/daylight basement & attached 3-car garage....1997 UBC		2000
New	40 x 58 2000 Marlette		2000
New	2000 Marlette 40 x 66		2000
New	Approved Basic #00-102509 BP	Plan: 2106 Two Story SFR - 1997 UBC	2000
New	2-story SFR w/attached 3-car garage.....1997 UBC		2000
New	2 story sfr w/3 car garage		2000
New	One-story SFR w/attached garage		2000
New	2-story SFR w/attached 3-car garage....1997 UBC		2000
New	Approved Basic #00-108051 BP	Plan: #1818/Getchell Rambler style SFR 1997 UBC	2000
New	Rambler w/3 Car		2000
New	2043 s.f. rambler w/3 car garage		2000
New	Rambler w/attached 3-car garage....1997 UBC		2000
New	2274 sf SFR with attached garage		2000
New	3429 sf 2-story w/834 sf garage and 66sf covered deck/porch		2000
New	Approved Basic #00-105576 BP	Plan: 992542 Two Story SFR - 1997 UBC	2000
New	2 Story w/ 3 Car		2000
New	Approved Basic #00-107111 BP	Rambler Style SFR - 1997 UBC	2000
New	Approved Basic #00-109792 BP	Rambler SFR - 1997 UBC	2000
New	Approved Basic #00-102874 BP	Builders Plan #00-01 Two Story SFR - 1997 UBC	2000
New	2 Story w/3 Car		2000
New	2542 sf 2-story w/680 sf garage, and 40 sf covered deck/porch		2000
New	2-Story SFR w/attached garage.		2000
New	Two-story SFR w/attached garage		2000
New	Approved Basic 00-107111 BP	Rambler style SFR.....1997 UBC	2000
New	27x40 2000 Skyline Greenbriar		2000
New	SFR over Garage Shop		2000
New	2000 40 x 60 Silvercrest		2000
New	2 story sfr w/3 car garage		2000
New	Approved Basic #99-102550BP	Plan: 2064 Rambler Style SFR - 1997	2000
New	Two Story SFR - 1997 UBC		2000
New	Approved Basic #99-100953BP	Two Story SFR - 1997 UBC	Plan: 71 2000
New	Approved Basic #98-107691BP	Option Approved: 3rd car bay Two Story SFR - 199	2000
New	Approved Basic #99-100955BP	Two Story SFR - 1997 UBC	Plan: 7 2000
New	Approved Basic #99-100953BP	Two Story SFR - 1997 UBC	Plan: 71 2000
New	Approved Basic #99-114151 BP	Plan: 5722 without bonus Two Story SFR - 1997 UBC	2000
New	Approved Basic #99-100950BP	Two Story SFR - 1997 UBC	Plan: 71 2000
New	Approved Basic #99-101219BP	Two Story SFR - 1997 UBC	Plan: 71 2000
New	Approved Basic #99-100953BP	Two Story SFR - 1997 UBC	Plan: 71 2000
New	Approved Basic #99-109705 BP	Plan: 7006 C Two Story SFR - 1997 UE	2000
New	Approved Basic #99-100953BP	Two Story SFR - 1997 UBC	Plan: 71 2000

Accessory Dwelling Units

Index # - File Name: 1.0022 - Single Family Dwellings Data\_Snohomish County.pdf

New	Approved Basic #99-103342BP	Plan: 5222 Two Story SFR - 1997	2000
New	Approved Basic #99-100950BP	Two Story SFR - 1997 UBC	Plan: 71 2000
New	Approved Basic #98-107691BP	Option Approved: 3rd car bay Two Story SFR - 1997 UBC	2000
New	Approved Basic #99-100953BP	Two Story SFR - 1997 UBC	Plan: 71 2000
New	Approved Basic #99-114151 BP	Plan: 5722 without/bonus Two Story SFR -	2000
New	Approved Basic #99-103342BP	Plan: 5222 Two Story SFR - 1997	2000
New	Approved Basic #99-100950BP	Two Story SFR - 1997 UBC	Plan: 71 2000
New	Approved Basic #98-107691BP	Option Approved: 3rd car bay Two Story SFR - 1997 UE	2000
New	Approved Basic #99-103342BP	Plan: 5222 Two Story SFR - 1997 UBC	2000
New	Approved Basic #98-107691BP	Option Approved: 3rd car bay Two Story SFR - 1997 UBC	2000
New	Approved Basic #99-101215BP	Two Story SFR - 1997 UBC	Plan: 71 2000
New	Approved Basic #99-10095BP	Two Story SFR - 1997 UBC	Plan: 70 2000
New	Approved Basic #99-114150 BP	Plan: 5622 w/bonus Two Story SFR - 1997 UBC	2000
New	Approved Basic #99-100953BP	Two Story SFR - 1997 UBC	Plan: 71 2000
New	Approved Basic #99-101219BP	Two Story SFR - 1997 UBC	Plan: 71 2000
New	Approved Basic #98-107691BP	Option Approved: 3rd car bay Two Story SFR - 1997 UBC	2000
New	Approved Basic #99-100950BP	Two Story SFR - 1997 UBC	Plan: 71 2000
New	Approved Basic #99-100956BP	Two Story SFR - 1997 UBC	Plan: 7 2000
New	Approved Basic #99-101219BP	Two Story SFR - 1997 UBC	Plan: 71 2000
New	Two Story with attached two car garage.		2000
New	2-Story SFR w/attached garage		2000
New	28 x 40 2000 Redman		2000
New	Approved Basic #99-103349BP	Plan: 5318 Two Story SFR - 1997	2000
New	Approved Basic #99-101211BP	Two Story SFR - 1997 UBC	Plan: 5023/5123 w 2000
New	Approved Basic #99-103342BP	Plan: 5222 Two Story SFR - 1997	2000
New	Approved Basic #99-101211BP	Two Story SFR - 1997 UBC	Plan: 5023/5123 w 2000
New	Approved Basic #99-103347BP	Plan: 4001 Two Story SFR - 1997	2000
New	Approved Basic #99-103574BP	Plan: 4002 Two Story SFR - 1997 UB	2000
New	Approved Basic #99-115677 BP	Plan #2065 Two Story SFR - 1997 UBC	2000
New	Approved Basic #98-110273BP	Two Story SFR - 1997 UBC	Plan: #553 2000
New	Approved Basic #98-110278BP	Two Story SFR - 1997 UBC	Plan: #552 2000
New	2 story sfr w/2 car garage		2000
New	Two-story SFR w/attached garage		2000
New	SFR w/basement & attached carport		2000
New	2322 sf 2-story w/860 sf covered porch, and 484 sf garage, w/220 sf covered breezeway - 1997		2000
New	Rambler w/attached 2-car garage....1997 UBC		2000
New	Approved Basic #98-110278BP	Two Story SFR - 1997 UBC	Plan: #552 2000
New	Rambler style SFR w/attached garage.		2000
New	2-Story SFR w/attached garage and covered porch.		2000
New	2917 sf 2-story w/596 sf garage and 11 sf covered deck/porch		2000
New	Rambler Style SFR - 1997 UBC	Plan: 1909	2000
New	Approved Basic #00-109412 BP	Plan 2400 Two-story SFR w/attached gar	2000
New	Approved Basic #00-101994 BP	Plan: 2330 Two Story SFR - 1997 UBC	2000
New	Approved Basic #99-109807 BP	Plan: 2768 Two Story SFR - 1997 UBC	2000
New	Approved Basic #99-109807 BP	Plan: 2768 Two Story SFR - 1997 UBC	2000
New	Approved Basic #99-113027 BP	Plan: 2621 Two Story SFR - 1997 U	2000
New	2-Story SFR w/attached 2-car garage....1997 UBC		2000



Accessory Dwelling Units

Index # - File Name: 1.0022 - Single Family Dwellings Data\_Snohomish County.pdf

New	Approved Basic #98-110372BP	Two Story SFR - 1997 UBC	Plan: #2575 Elv	2000
New	Approved Basic #98-110372BP	Two Story SFR - 1997 UBC	Plan: #2575 Elv	2000
New	Approved Basic #99-115032 BP		Plan: 3319 Elv A Two Story SFR - 1997 UBC	2000
New	Approved Basic #00-101967 BP		Plan: #2575 (Elev. B) Two Story SFR - 1997 UBC	2000
New	Approved Basic #00-108822 BP		Plan: 1670 Elev. B Two Story SFR - 1997 UBC	2000
New	2-story SFR w/attached 2-car garage....1997 UBC			2000
New	Approved Basic #99-109806 BP		Plan: 2628 Two Story SFR - 1997 UBC	2000
New	Approved Basic #99-113027 BP		Plan: 2621 Two Story SFR - 1997 UBC	2000
New	Approved Basic #99-110534 BP		Plan: 2528 Two Story SFR - 1997 UBC	2000
New	Approved Basic #00-101137 BP		Plan: 2228 Two Story SFR - 1997 UBC	2000
New	Approved Basic #99-110537 BP		Plan: 2576 Two Story SFR - 1997 UBC OP	2000
New	Approved Basic #00-110368 BP		Plan: 2056 Two Story SFR - 1997 UBC	2000
New	Approved Basic #00-107977 BP		Plan: 1980 Rambler Style SFR - 1997 UBC	2000
New	Approved Basic #99-110535 BP		Plan: 2834 Two Story SFR - 1997 UBC	2000
New	Approved Basic #99-110535 BP		Plan: 2834 Two Story SFR - 1997 UBC	2000
New	Approved Basic #99-110537 BP		Plan: 2576 Two Story SFR - 1997 UBC OP	2000
New	SFR with Attached Garage			2000
New	Two Story SFR - 1997 UBC			2000
New	Approved Basic #98-109883BP	Two Story SFR - 1997 UBC	Plan: #244	2000
New	Approved Basic #00-101970 BP		Plan: #2990 (Elev. B) Two Story SFR - 1997 UBC	2000
New	Two Story SFR - 1997 UBC			2000
New	Approved Basic #98-109883BP	Two Story SFR - 1997 UBC	Plan: #244	2000
New	Approved Basic #98-110372BP	Two Story SFR - 1997 UBC	Plan: #2575 Elv	2000
New	Approved Basic #99-115032 BP		Plan: 3319 Elv A Two Story SFR - 1997 UBC	2000
New	Approved Basic #99-115034 BP		Plan: 3319 Elv B Two Story SFR - 1997 UBC	2000
New	Approved Basic #00-109062 BP		Plan: 1906 Elev. C Two Story SFR - 1997 UBC	2000
New	Approved Basic #98-110372BP	Two Story SFR - 1997 UBC	Plan: #2575 Elv	2000
New	Approved Basic #98-109883BP	Two Story SFR - 1997 UBC	Plan: #244	2000
New	Approved Basic #99-110098 BP	Two Story SFR - 1997 UBC	Plan: #21	2000
New	Approved Basic #99-103307BP		Plan: 2747 - Elevation C Two Story SFR	2000
New	Approved Basic #99-113027 BP		Plan: 2621 Two Story SFR - 1997 UBC	2000
New	Approved Basic #99-109807 BP		Plan: 2768 Two Story SFR - 1997 UBC	2000
New	2 Story SFR with attached garage			2000
New	Approved Basic #00-101972 BP		Plan: #2446 (Elev. A) Two Story SFR - 1997 UBC	2000
New	Approved Basic #00-101061 BP		Plan: 2717 B Two Story SFR - 1997 UBC	2000
New	Approved Basic #99-109807 BP		Plan: 2768 Two Story SFR - 1997 UBC	2000
New	Approved Basic #98-109885BP		OPTION Approved Two Story SFR - 1997 UBC	2000
New	Two Story SFR - 1997 UBC	Plan: 2511		2000
New	Approved Basic #99-109807 BP		Plan: 2768 Two Story SFR - 1997 UBC	2000
New	Approved Basic #99-109807 BP		Plan: 2768 Two Story SFR - 1997 UBC	2000
New	Rambler w/ 2 Car			2000
New	Approved Basic #99-114893 BP		Plan: 1-A Two Story SFR - 1997 UBC	2000
New	Approved Basic #00-101064 BP		Plan: 2481 A Two Story SFR - 1997 UBC	2000
New	Two Story SFR - 1997 UBC	Plan: 2770 B		2000
New	Two Story SFR - 1997 UBC	Plan: 2539 side load		2000
New	Two Story SFR - 1997 UBC	Plan: 2770		2000
New	Approved Basic #99-11525 BP		Plan: 2481 B Two Story SFR - 1997 UBC	2000

Accessory Dwelling Units

Index # - File Name: 1.0022 - Single Family Dwellings Data\_Snohomish County.pdf

New	Two Story SFR - 1997 UBC	Plan: 2770	2000
New	Approved Basic #00-101064 BP	Plan: 2481 A Two Story SFR - 1997 UBC	2000
New	Approved Basic #99-11525 BP	Plan: 2481 B Two Story SFR - 1997 UB	2000
New	Two Story SFR - 1997 UBC	Plan: 2770 B	2000
New	Approved Basic #99-115249 BP	Plan: 2838 B Two Story SFR - 1997 U	2000
New	1134 s.f. rambler		2000
New	Two-story SFR w/attached garage		2000
New	2 story sfr w/3 car garage		2000
New	2-Story SFR w/attached garage.		2000
New	One-story SFR w/attached garage		2000
New	2353 sf 2-story w/663 sf garage and 72 sf open deck		2000
New	Approved Basic 00-102136BP Rambler Style SFR - 1997 UBC		2000
New	Rambler style SFR.....1997 UBC		2000
New	Approved Basic #99-103434-BP	Rambler Style SFR - 1997 UBC	2000
New	Two-story SFR w/attached garage		2000
New	One-story SFR w/finished & semi-finished basement		2000
New	Approved Basic #00-107844 BP	Plan: 2327 w/basement Two Story SFR w/unfini	2000
New	Approved Basic #00-107853 BP	Plan: 2C w/basement SFR w/unfinished basement	2000
New	2 story sfr		2000
New	Two-story SFR w/unfinished basement & attached garage		2000
New	2-story SFR w/attached 3-car garage....1997 UBC		2000
New	2380 sf 2-story w/400 sf garage, 108 sf covered porch and 108 sf open deck		2000
New	Approved Basic #99-105402BP	Plan: 2650 A/3 SG Two Story SFR - 199	2000
New	Approved Basic #99-105402BP	Plan: 2650 A/3 SG Two Story SFR - 199	2000
New	Approved Basic #99-109495 BP	Plan: 2771 Two Story SFR - 1997 U	2000
New	2 Story SFR with attached garage		2000
New	Rambler style SFR with attached garage		2000
New	2 Story w/3 Car		2000
New	2-story SFR w/attached 2-car garage....1997 UBC		2000
New	Approved Basic #98-116988BP	Option Approved: Different main floor plan la	2000
New	Two-story SFR w/attached garage	Submitted plan change for floor joists 10/06/00 DC	2000
New	2-story SFR w/attached 3-car garage.....1997 UBC		2000
New	2000 Oakwood 27 x 48		2000
New	2000 Palm Harbor 28 x 58		2000
New	2000 Palm Harbor 28 x 58		2000
New	2000 Golden West GS60 28 x 66		2000
New	28 x 56 2000 Marlette Enhancement		2000
New	2000 Palm Harbour 28 x 58		2000
New	27x48, 2000 Palm Harbor		2000
New	27x66, 2000 Palm Harbor		2000
New	Rambler w/bonus room above garage w/attached 3-car garage.....1997 UBC.		2000
New	Two Story SFR - 1997 UBC	Plan: 2368	2000
New	Approved Basic #98-150635BP	Plan: 1063 Two Story SFR - 1997 UBC	2000
New	Approved Basic #00-107081 BP	Plan: Revised Rambler w/bonus Rambler Style SFR - 1997 U	2000
New	Rambler style SFR.....1997 UBC		2000
New	Approved Basic #99-109495 BP	Plan: 2771 Two Story SFR - 1997 U	2000
New	Approved Basic No. 00-105522 BP	Bldrs Plan: 122 w/out Bonus Rambler style SFR..	2000

Accessory Dwelling Units

Index # - File Name: 1.0022 - Single Family Dwellings Data\_Snohomish County.pdf

New	Approved Basic #98-150984BP	Plan: 5911-B	Two Story SFR - 1997 UBC	2000
New	Approved Basic #99-113246 BP	Plan: 2632	Two Story SFR - 1997 UB	2000
New	2 Story with 3 Car			2000
New	2-story SFR w/attached 3-car garage...1997 UBC			2000
New	Approved Basic #98-150985BP	Plan # 5911E	Two Story SFR - 1997 UBC	2000
New	Rambler style SFR with attached garage			2000
New	27 x 44 - 2000 - Palm Harbor - Mobile Home			2000
New	27 x 56 2000 Palm Harbor			2000
New	2000 27 x 44 Goldenwest			2000
New	27x58, 1999 Palm Harbor			2000
New	2000 Palm Harbor 27 x 64			2000
New	40x60, 2000 Silvercrest			2000
New	28x60 2000 Marlette			2000
New	2000 27 x 48 Palm Harbor			2000
New	27 X 48 Palm Harbor 2000			2000
New	28x44, 2000 Fleetwood			2000
New	27x66, 2000 Skyline			2000
New	Approved Basic #98-150633BP	Plan: 44 er	Two Story SFR - 1997	2000
New	Two Story SFR - 1997 UBC	Plan: 3219		2000
New	Approved Basic #98-110516BP	Option Approved: Garage door design & entry change	Tv	2000
New	Approved Basic #99-109495 BP	Plan: 2771	Two Story SFR - 1997 U	2000
New	Approved Basic #98-150628BP	Plan: 50 er	Two Story SFR - 1997 UBC	2000
New	1999 Palm Harbor 40 x 48			2000
New	Approved Basic #98-150632BP	Plan: 45 er	Two Story SFR - 1997	2000
New	Two-story SFR w/attached garage			2000
New	Single story SFR with attached three car garage.			2000
New	Approved Basic #00-101410 BP	Plan: 2415	Two Story SFR - 1997 UBC	2000
New	Approved Basic #99-109482 BP	Plan: 2288	Two Story SFR - 1997 UBC	2000
New	Two-story SFR w/attached garage			2000
New	44x39, 2000 Appalachian			2000
New	Approved Basic #99-109481 BP	Plan: 2248 -3	Two Story SFR - 1997 UB	2000
New	2 Story w/3 Car			2000
New	New 1773sf, two story, SFR with two car garage.			2000
New	2 story sfr w/garage			2000
New	2 story sfr w/garage & carport			2000
New	Approved Basic #99-109481 BP	Plan: 2248 -3	Two Story SFR - 1997 UB	2000
New	2001 - 49 x 40 Skyline/Greenbrier Mobile Home			2000
New	Approved Basic #00-104279 BP	Plan: 2220 S	SFR w/finished lower floor - 1997 UI	2000
New	3373 sf rambler w/1132 sf garage, w/481sf covered porch/lanai			2000
New	Approved Basic #99-115597 BP	Builders Plan 1640	Two-story SFR - 1997 UBC	2000
New	Two-story SFR w/attached garage			2000
New	Split w/ 2 Car			2000
New	1146 s.f. sfr w/558 s.f. basement & 2 car garage			2000
New	Approved Basic 99-104905BP		Rambler Style SFR - 1997 UBC	2000
New	Split Level SFR with attached garage			2000
New	2 story SFR with attached garage			2000
New	Approved Basic 99-104905BP		Rambler Style SFR - 1997 UBC	2000

Accessory Dwelling Units

Index # - File Name: 1.0022 - Single Family Dwellings Data\_Snohomish County.pdf

New	Rambler w/2 Car		2000
New	2-Story Daylight Basement SFR w/attached garage. SEPA review completed under 00-105695 C		2000
New	Two-story SFR w/unfinished basement		2000
New	One-story SFR w/attached garage		2000
New	SFR with loft - 1997 UBC		2000
New	1480sf single story with attached two car garage.		2000
New	28 X 48 2000. Access permit issue resolved, opened permit to approve final inspection ahusby		2000
New	Split level SFR w/attached garage		2000
New	1998 - 66 x 41 Goldenwest Country Estate II		2000
New	48x27, 2000 Skyline Greenbrier		2000
New	1999 40 X 56 Golden West		2000
New	Approved Basic #99-102451BP	Plan: Cindy SFR w/finished basement - :	2000
New			2000
New	1258 sf 2-stroy w/272 sf finished basement and 336 sf garage		2000
New	Rambler w/attached 2-car garage...1997 UBC		2000
New	Approved Basic #00-107717 BP	Bldrs Plan No. 1890 Rambler style SFR.....1997 U	2000
New	Approved Basic #00-108883 BP	Plan: 2081 2-story SFR w/finished Basement....19	2000
New	Two Story SFR with 100 sq ft Finished and 548 sq ft Semi Finished Basement and Attached Gara		2000
New	Two Story SFR - 1997 UBC - Per IR05-124475 SFR was finaled .		2000
New	2 story SFR with attached garage		2000
New	2-story SFR w/attached 2-car garage....1997 UBC		2000
New	2-story SFR w/attached 3-car garage...1997 UBC		2000
New	Two Story SFR w/unfinished basement - 1997 UBC		2000
New	2 story sfr w/unfinished basement & 3 car garage		2000
New	1905 sf rambler w/900sf open deck		2000
New	2-Story SFR over semi-fin. Daylight Basement w/attached Garage.		2000
New	82 X 30 Rambler		2000
New	Finald on 99-100275 by Cecil Koch, 9/29/00. Convert 1904-Sq. Ft. of existing crawl space to N		2000
New	Two-story SFR w/attached garage		2000
New	Rambler w/ 2 Car		2000
New	2-Story SFR over Partial Basement w/attached garage.		2000
New	Two Story SFR w/unfinished basement - 1994 UBC	Plan #Amherst	2000
New	New 2278sf SFR with attached three car garage		2000
New	One-story SFR w/attached garage		2000
New	Two Story SFR - 1994 UBC	Plan #2965	2000
New	2- Story SFR w/attached garage.		2000
New	2-story SFR w/attached 2-car garage...1997 UBC		2000
New	2 story sfr w/3 car garage		2000
New	2 Story SFR with attached garage - 1994 UBC		2000
New	2774 2-story w/1464 sf finished basement, 684 sf garage and 34 sf covered deck/porch		2000
New	Approved Basic #00-107869 BP	Plan #2780 Two Story SFR - 1997 UBC	2000
New	14 x 66 - 1990 - Marlett		2000
New	2 story SFR with attached garage and covered porch		2000
New	Rambler style SFR with upstarirs bonus room and attached garage		2000
New	Two Story SFR with Attached Garage		2000
New	Two Story SFR With Unfinished Basement and Attached Garage		2000
New	Two-story SFR w/attached garage		2000

Accessory Dwelling Units

Index # - File Name: 1.0022 - Single Family Dwellings Data\_Snohomish County.pdf

New	2-Story SFR over unfin. basement w/attached garage.	2000
New	40 x 60 TW Goldenwest	2000
New	Mid-Entry SFR w/attached 2-car garage....1997 UBC	2000
New	Rambler w/3 Car	2000
New	Rambler Style SFR w/attached garage.	2000
New	Two Story SFR with Attached Garage and Unfinished Basement	2000
New	Two-story SFR w/attached garage	2000
New	28x44 (2001) Liberty	2000
New	2-story SFR w/attached 3-car garage.....1997 UBC	2000
New	Rambler style SFR with attached garage and attached RV garage	2000
New	Rambler w/ 3 Car Accessory Apartment - 1997 UBC	2000
New	Rambler - 2062 Sq Ft	2000
New	2 story SFR with attached garage and covered porch	2000
New	2-story SFR w/attached carport....1997 UBC	2000
New	2-Story SFR w/attached garage & 612-sf Unfin. Bonus room over garage.	2000
New	Approved Basic #00-106932 BP Plan: 394 (2) A Tri-Level Style SFR.....1997 UBC	2000
New	Approved Basic #00-106429 BP Plan #496 Elev. A - crawl space/ w/o bump out Two Story SFR	2000
New	12 x 56 - 1969 Fleetwood Mobile Home.	2000
New	Two Story SFR	2000
New	Rambler w/semi-finished basement & attached 3-car garage....1997 UBC	2000
New	4-car garage w/850 sq ft of living space on the 2nd floor.....1997 UBC	2000
New	1 Story w/2 Car & semi-fin basement	2000
New	Daylight Rambler w/618 sf fin bsmt, 1020 unfin bsmt	2000
New	28 x 66 2000 Marlette	2000
New	1332 s.f. sfr w/900 s.f. finished basement & 2 car garage	2000
New	Two Story SFR - 1997 UBC	2000
New	2 story sfr w/3 car garage	2000
New	Single Story SFR w/1 Car Garage	2000
New	2-Story SFR w/attached garage.	2000
New	2-story SFR w/ 3-car garage attached by a breezeway & a 593 sq ft studio above the garage.....	2000
New	Two-story SFR	2000
New	Rambler style SFR with attached garage and covered porch	2000
New	Two story with three car garage.	2000
New	1 story SFR with finished basement	2000
New	Two story SFR with attached two car garage.	2000
New	Two Story SFR with Attached Garage	2000
New	Two-story SFR w/attached garage	2000
New	2000 Silvercrest SV54 39 x 52	2000
New	Two-story SFR w/attached garage	2000
New	2-Story SFR w/attached garage.	2000
New	60 X 40 Silvercrest 2000	2000
New	24 x 52 - 1999 - Fleetwood	2000
New	2 Story w/3 Car	2000
New	Two Story SFR with Attached Garage	2000
New	44 X 26 River Crest 2000 for use as Park Manager s Residence in Gold Bar Nature Trails Campgrc	2000
New	27 x 40 - 2000 Greenbrier	2000
New	2-story SFR w/attached 2-car garage....1997	2000

Accessory Dwelling Units

Index # - File Name: 1.0022 - Single Family Dwellings Data\_Snohomish County.pdf

New	2445 sf 2-story w/156 sf covered deck/porch and 504 sf open deck	2000
New	One-story duplex w/attached garage with 2 story central common area	2000
New	1999 25x38 Fleetwood Deer Creek	2000
New	26 8 x 68 Year 2000 Country Cottage	2000
New	Two-story SFR	2000
New	2 story SFR with attached garage	2000
New	2427 sf 2-story w/1965 sf unfinished basement, 693 sf garage, 200 sf covered deck/porch, and 4	2000
New	2-story SFR w/attached 2-car garage....1997 UBC	2000
New	2 story sfr w/unfinished basement & 3 car garage	2000
New	840-sf SFR + 840-sf attached garage - 1994 UBC	2000
New	2 Story w/3 Car	2000
New	2-story SFR w/attached 2-car garage....1997 UBC	2000
New	12 X 40 Nashua 1969	2000
New	1985 Fuqua 14 x 66	2000
New	27 x 66 - 2000 Greenbriar	2000
New	Two-story SFR w/finished basement	2000
New	1800 sq ft Rambler style SFR....1997 UBC	2000
New	2 story SFR with attached garage	2000
New	Approved Basic #99-114928 BP Plan: 929H Two Story SFR - 1997 UBC	2000
New	2 story sfr w/3 car garage	2000
New	Split-entry SFR w/attached 2-car garage....1997 UBC	2000
New	2 story sfr with unfinished basement and 2 car garage. Ref. 98-103025.	2000
New	24 x 60 1973 Kentwood Mobile Home. EXPIRED W/O FINAL. PERMIT SENT TO FICHE, 7/25/02.	2000
New	24 x 56 - 1977 - Bon Prix	2000
New	One story SFR w/basement	2000
New	2 story sfr with 3 car garage	2000
New	Rambler w/2 Car Note: TDP Base fee was paid under 99-114278 AB	2000
New	One-story SFR w/attached garage	2000
New	2-Story SFR w/attached garage.	2000
New	2-story SFR w/semi-finished daylight basement w/attached 3-car garage w/bonus room above t	2000
New	Rambler Style SFR - 1997 UBC Plan: 99111	2000
New	2-Story SFR w/attached garage.	2000
New	2136 sf 2-story w/673 sf garage and 149 sf covered deck/porch w/148 sf open deck	2000
New	Rambler w/semi-finished daylight basement....1997 UBC	2000
New	27x52 2001 Oakwood	2000
New	14x66 (1995) Guerdon	2000
New	2000 Liberty Independence 60 x 40	2000
New	Two-story SFR	2000
New	1492 sf SFR w/1400 sf daylight semi-finished basement, 462 sf garage, 32 sf covered deck/porcht	2000
New	2000 Redman 4563B 28 x 56	2000
New	24x60, 1976 Frontier Mobile Home	2000
New	Two-story SFR w/attached garage	2000
New	2347 2-story w/440 sf garage and 200sf open deck	2000
New	60 x 28 - 1983 - GoldenWest	2000
New	Split Level SFR w/basement & garage.	2000
New	Two-story Log SFR w/semi-finished basement	2000
New	2-story SFR w/attached garage.....1997 UBC	2000

Accessory Dwelling Units

Index # - File Name: 1.0022 - Single Family Dwellings Data\_Snohomish County.pdf

New	24x56, 1984 Commador	2000
New	Rambler Style Accessory Apartment - 1994 UBC	2000
New	One-story SFR w/attached garage	2000
New	14 x 66 - 1980 - Fleetwood - Mobile Home.	2000
New	850 sf detached accessory apartment w/garage	2000
New	2 story SFR with attached garage	2000
New	28 x 36 Log Style SFR with loft	2000
New	Approved Basic #98-110213BP	Plan #1333 Two Story Duplex - 1997 UBC
New	2 story sfr w/3 car garage	2000
New	2808 2 story w/833 sf unfinished basement and 81 sf covered deck/porch (no garage)	2000
New	2 story sfr,breezeway & 2 car garage	2000
New	836 sf SFR over garage	2000
New	27 x 66 1985 Guerdon	2000
New	2 story sfr w/3 car garage	2000
New	One-story SFR w/attached garage	2000
New	1905 sf 2-story w/436 sf garage and 36 sf covered deck/porch	2000
New	2-story SFR w/covered porch.....1997 UBC	2000
New	38x60 Fuqua Ranswood	2000
New	MH conversion to Guest House Single wide 14 x 60 1982	2000
New	1995 Fleetwood 27 x 60	2000
New	2-story SFR w/800 sq ft of covered porch.....1997 UBC	2000
New	2 story SFR with covered porch and deck. - 1997	2000
New	Convert existing temporary dwelling to permanent mobile home (1999 27 x 66 Fleetwood)	2000
New	Two Story SFR	2000
New	2 story sfr w/3 car garage	2000
New	Rambler w/unfinished daylight basement & attached 3-car garage....1997 UBC	2000
New	Two-story SFR w/attached garage	2000
New	SFR w/ attached garage	2000
New	Two-story SFR w/attached garage	Plan: Montreux 106
New	Two-story SFR w/attached garage	Plan: Baccarat
New	2-story SFR w/unfinished basement & w/an attached 2-car garage.....1997 UBC	2000
New	Approved Basic #00-103152 BP	Plan: 2350 Two Story SFR - 1997 UBC
New	Basement Rambler w/finished basement, 2-nd floor bonus and 3-car garage.	2000
New	Two Story SFR with Attached Garage	2000
New	843-sf - Detached Accessory Apartment w/180-sf Carport & 180-sf Covered Porch.	2000
New	2000 Fleetwood 7664B 66 x 40	2000
New	Two-story SFR w/unfin basement & attached garage	2000
New	2 story sfr w/finished basement & attached garage	2000
New	Duplex -- Rambler style with attached carports	2000
New	Two-story duplex with attached garage	2000
New	2 story sfr w/2 car garage	2000
New	1979 14 x 66 Broadmore (Fleetwood)	2000
New	2-story SFR w/finished basement.....1997 UBC	2000
New	2-Story SFR w/attached garage.	2000
New	2 Story w/ 2 Car	2000
New	2 Story w/ 2 Car	2000
New	2 story sfr w/2 car garage	2000

Accessory Dwelling Units

Index # - File Name: 1.0022 - Single Family Dwellings Data\_Snohomish County.pdf

New	Builders Plan 1876	One-story SFR w/ur	2000
New	2071 sf 2-story w/620 sf garage and 200 sf covered deck/porch		2000
New	Fleetwood MH installed w/o permit. To be permitted as guesthouse.		2000
New	14 x 66	1978 Nashua	2000
New	384 sq. ft. SFR w/attached garage -	1997 UBC	2000
New	28 x 56	1999 Fleetwood	2000
New	40 x 25	Detached Accessory Apartment	2000
New	SFR with daylight basement and attached garage		2000
New	2 story sfr w/2 car garage		2000
New	2 story sfr with unfinished basement & 3 car garage		2000
New	1994 27 x 52	Goldenwest	2000
New	2000 Goldenwest VW6000 IF 60 x 27		2000
New	Two-story SFR w/attached garage		2000
New	26 8 x48	2000 American Homestar	2000
New	Convert existing TD/MH to a guest house		2000
New	2090 sf rambler w/856 sf garage and 96 sf covered deck/porch		2000
New	Rambler Style SFR w/attached garage.		2000
New	52x24,	1978 Titan	2000
New	40x66	1990 Silvercrest	2000
New	40 X 70	- 2000 - Palm Harbor	2000
New	To convert 56x28 (1999) Redman to permanent residence		2000
New	1982 24 x 40	Gibralter	2000
New	Rambler Style Duplex with attached double garages.		2000
New	Approved Basic #99-115103 BP	Plan: 1452 Rambler Style SFR - 1997 I	2000
New	1998 2 story w/440 sf garage, 94 sf covered porch/deck and 120 sf open patio		2000
New	One-story SFR w/attached garage		2000
New	2 Story w/2 Car		2000
New	1999 40 x 66	Meadow Brook	2000
New	28 x 48	2001 Goldenwest	2000
New	14x68,	1979 Ridgeway GUEST HOUSE	2000
New	2535 s.f. w/1090 unfinished basement & 3 car garage		2000
New	1428 sf 2-story w/54 sf finished basement, 758 sf garage and 220 sf covered deck/porch and 10		2000
New	2 Story w/3 Car. HOMEOWNER CHANGED FROM ATWOOD CONST. TO BLUE HORIZON CONST. 9		2000
New	2-story SFR w/unfinished daylight basement.....1997 UBC		2000
New	Two-story SFR w/attached garage		2000
New	Rambler style SFR.....1997 UBC		2000
New	Approved Basic #00-102404 BP	Plan: 1228 Rambler Style SFR - 1997 UBC	2000
New	2-story Duplex w/2 attached 2-car garages..... 1997 UBC		2000
New	Two-story SFR w/attached garage		2000
New	2 story sfr w/2 car garage & boat storage		2000
New	24 x 60	1973 Champion	2000
New	27 X 56 w/ bumpout,	2000 Oakwood	2000
New	2-Story SFR w/attached garage.		2000
New	1999 Oakwood 27 x 55		2000
New	Approved Basic #98-110231BP	Plan: Rutledge 1365 One-story SFR w/finis	2000
New	Approved Basic #00-104670 BP	Plan: 1914 Two Story w/finished basen	2000
New	Approved Basic #00-104670 BP	Plan: 1914 Two Story w/finished basem	2000



Accessory Dwelling Units

Index # - File Name: 1.0022 - Single Family Dwellings Data\_Snohomish County.pdf

New	Approved Basic #00-104670 BP	Plan: 1914 Two Story w/finished basem	2000
New	Approved Basic #00-104665 BP	Plan: 1620 Two Story SFR - 1997 UBC	2000
New	Approved Basic #98-110231BP	Plan: Rutledge 1365 One-story SFR w/finisl	2000
New	Approved Basic #00-104665 BP	Plan: 1620 Two Story SFR - 1997 UBC	2000
New	Approved Basic #98-110231BP	Plan: Rutledge 1365 One-story SFR w/finisl	2000
New	2-Story SFR		2000
New	2285 sf sfr w/1504 sf semi-finished basement, 722 sf unfinished basement, 768 sf garage, 114 sf		2000
New	2 story SFR with covered porch		2000
New	27x66 1993 Goldenwest.		2000
New	Approved Basic #98-110058BP	Plan #1214 Split Entry Style SFR w/bas	2000
New	2 story sfr w/unfinished basement & 2 car garage		2000
New	2-Story SFR w/unfin. basement & attached garage.		2000
New	2 story sfr w/1 car garage		2000
New	2968 sf 2-story w/816 sf garage, 43 sf covered porch,and 600 sf open deck		2000
New	2 story sfr w/3 car garage		2000
New	28x66 2000 Marlette		2000
New	40x60 2000 Palm Harbor		2000
New	2000 sq ft Log Home		2000
New	1 Story with Basement Garage		2000
New	Mid-entry style SFR w/basement garage.		2000
New	Two story w/attached 2-car garage...1997 UBC		2000
New	Mid-entry style SFR w/basement garage.		2000
New	Approved Basic #99-101683BP SFR w/finshed basement - 1997 UBC		2000
New	2123 sf rambler w/720 sf finished basement and 963 sf semi-finished basement, and 360 sf ope		2000
New	2 story SFR with attached garage		2000
New	Rambler Style SFR w/attached garage		2000
New	40 X 70 Golden West 2000		2000
New	2-Story SFR w/Attached Garage.		2000
New	3958 sf 2-story w/900 sf garage, and 490 sf covered deck/porch		2000
New	Single story SFR w/daylight basement & loft.....1997 UBC		2000
New	1998 Marlette 42 x 27		2000
New	2- Story with attached garage and covered porch - 1994 UBC		2000
New	OK to renew per Gloria Baker, 6/20/02 - jls 2 Story w/3 Car		2000
New	Two Story SFR w/unfinished basement - 1997 UBC		2000
New	2 story SFR with attached garage....1997 UBC		2000
New	27x44 1999 Goldenwest/Fuller Bay to be used as a guesthouse		2000
New	63 X 27 Oakwood 2000		2000
New	24 x 60 - 1985 - Fleetwood		2000
New	2 story SFR with finished basement and attached garage		2000
New	Rambler w/attached 2-car garage....1997 UBC		2000
New	2 Story w/3 Car		2000
New	2051 Sq Ft Rambler with Attached Garage		2000
New	Rambler w/3 Car		2000
New	SFR w/720 sf main floor, 720 sf 2nd floor, and 117 sf 3rd floor. w/96 sf covered porch and 192 s		2000
New	850 sf Detached AA with 1078 sf shop attached		2000
New	3087 sf 2-story w/660 sf garage and 150 sf covered deck/porch and 200 sf open deck		2000
New	Rambler Style SFR w/attached garage.		2000

Accessory Dwelling Units

Index # - File Name: 1.0022 - Single Family Dwellings Data\_Snohomish County.pdf

New	752 sf Apartment over 887 sf Garage		2000
New	2164 s.f. rambler w/3 car garage		2000
New	Rambler with attached two car garage.		2000
New	1984 sf rambler w/1126 sf finished basement w/660 sf garage and 800 sf open deck, to be built		2000
New	27x48, 2000 Oakwood		2000
New	2-story SFR w/unfinished basement.....1997 UBC		2000
New	27 x 44 2000 Rivercrest		2000
New	28x66 (1979) Goldenwest		2000
New	28x56 1989 Marlette		2000
New	56 x 27 (2000) Mariette First Edition 9735		2000
New	Two-story SFR		2000
New	2000 40 x 60 Marlette		2000
New	14 x 70 - 1979 - Kentwood		2000
New	2039 sf rambler w/572 sf garage and 130 sf covered deck/porch		2000
New	12 x 60 - 1973 - Lamplighter Mobile Home as Guest House.		2000
New	Rambler w/daylight basement attached by a 10x8 breezeway to a 3-car garage....1997 UBC		2000
New	Two Story SFR with Attached Garage		2000
New	Two Story SFR - 1997 UBC	Plan: 1932	2000
New	1036 s.f. 2nd story sfr w/1036 s.f. 1st story garage		2000
New	2-story SFR w/unfinished basement & attached 3-car garage....1997 UBC		2000
New	One-story SFR w/finished basement & basement garage		2000
New	28x56 (2000) Marlette		2000
New	Approved Basic #98-150644BP	Builders Plan: Charlene Two story sfr wi	2000
New	2-Story SFR w/attached garage.		2000
New	2557 sf 2-story w/608 sf garage and 48 sf covered deck/porch and 32 sf open deck		2000
New	2 story sfr		2000
New	One-story SFR with two-car garage		2000
New	2 Story w/ 2 Car		2000
New	2001 28 x 40 Redmond Discovery		2000
New	Rambler style SFR		2000
New	40x66, 2000 Marlette		2000
New	Two-story SFR w/attached garage		2000
New	1702 sf rambler w/3 car garage		2000
New	Approved Basic #99-111975 BP	Plan: 1533 Two Story SFR - 199	2000
New	Approved Basic #99-113041 BP	Plan # 1438 (front entry garage) Two Story SFR - 199	2000
New	28 x 66 - 1977 - Kit		2000
New	14 x 60 1978 Ridgeway		2000
New	12 x 55 1969 Broadmore		2000
New	952 sf w/476 sf loft and 200 sf open deck		2000
New	Tri-Level style SFR w/attached garage.		2000
New	54x53 2000 Goldenwest		2000
New	Mid-Entry SFR w/attached 2-car garage...1997 UBC		2000
New	Mid-Entry style SFR w/Basement Garage		2000
New	1701 sf 2-story, w/800 sf basement, 460 sf garage, and 36 sf covered porch		2000
New	New 2 story SFR w/ attached 3 car garagae		2000
New	One-story SFR w/attached garage		2000
New	27x60 1999 Golden West		2000

Accessory Dwelling Units

Index # - File Name: 1.0022 - Single Family Dwellings Data\_Snohomish County.pdf

New	Two-story SFR w/finished basement	2000
New	2 story SFR replacing existing SFR over same area	2000
New	1-1/2 story sfr	2000
New	27x66, 2000 Marlette	2000
New	2 story sfr w/basement & 3 car garage	2000
New	EXPIRED WITHOUT COUNTY APPROVAL TO USE OR OCCUPY gb 1/22/15. 2 story garage with SI	2000
New	2000 28 x 40 Marlette	2000
New	27 x 66 2000 Oakwood	2000
New	2 story sfr w/2 car garage	2000
New	2-story SFR over daylight basement. Forest Practice Moratorium placed 3/25/95, LIFTED 7/21/	2000
New	2 story SFR to be built on existing foundation	2000
New	2000 Oakwood OK66001F 60 x 27	2000
New	2000 Oakwood OK66001F 27 x 66	2000
New	Two-story SFR	2000
New	2 story Residence	2000
New	2 story sfr w/garage	2000
New	2-story SFR w/attached 3-car garage....1997 UBC	2000
New	26x48 2001 Nashua	2000
New	Rambler style SFR w/unfin. Basement & attached garage.	2000
New	2698 sf rambler w/828 sf garage and 100 sf covered deck/porch	2000
New	2-story SFR....1997 UBC	2000
New	2 story SFR w/ basement w/2 car garage	2000
New	28 x 56 1986 Barrington. REF. 97-110745.	2000
New	2776 s.f. rambler	2000
New	2 story SFR with attached garage	2000
New	2-Story SFR w/attached garage.	2000
New	600-sf living space + 1860-sf garage/shop + 576-sf carport.	2000
New	SFR with loft and attached carport	2000
New	2 story sfr w/3 car garage	2000
New	Rambler style SFR with attached garage and bonus room above	2000
New	2561 rambler w/772 sf garage and 48 sf covered deck/porch	2000
New	2 story A Frame cabin	2000
New	600 sf SFR	2000
New	2 Story w/Finished Bsmt & 2 Car	2000
New	2601 s.f. residence w/1965 s.f. finished basement and 2 car garage w/2nd story shop	2000
New	1735 s.f. rambler w/2 car garage	2000
New	1978 Kentwood 24 x 56	2000
New	2 story SFR with covered deck	2000
New	2000 Greenbriar 27 x 40	2000
New	816 sq ft SFR over 3-car garage....1997 UBC	2000
New	2000 27 x 58 Palm Harbor	2000
New	26 x 46 detached accessory apartment with attached garage	2000
New	28x46 (1988) Fleetwood	2000
New	4394 sf 2-story w/552 sf garage, and 300 sf covered deck/porch	2000
New	1976 22 x 60 Kit	2000
New	27 x 64 Palm Harbor 2000	2000
New	VIOLATION: MacQuarrie - Permit for existing 10x55, 1962 Marlette	2000

Accessory Dwelling Units

Index # - File Name: 1.0022 - Single Family Dwellings Data\_Snohomish County.pdf

New	14 x 60 1980 Royale Mobile Home		2000
New	One-story SFR w/basement garage		2000
New	One-story duplex with attached garage		2000
New	Two-story SFR - 1997 UBC		2000
New	Rambler style SFR....1997 UBC		2000
New	2-Story SFR w/attached garage.		2000
New	2-Story SFR w/attached garage.		2000
New	2-Story SFR w/attached garage.		2000
New	849sf detached accessory apt. w/768sf attached garage		2000
New	2 story Duplex with attached garage		2000
New	2 Story w/3 Car		2000
New	2-Story SFR		2000
New	2 Story w/ 3 car		2000
New	2 Story w/ 3 car		2000
New	Approved Basic #99-112836 BP	Plan: #2461 Two Story SFR - 1997	2000
New	2 Story w/3 Car		2000
New	1987 Fleetwood 24 x 60		2000
New	Rambler w/finished basement & 3 car		2000
New	One-story duplex with attached garage		2000
New	2 Story w/unfin basement & 3 Car		2000
New	1999 25 x 66 Fleetwood		2000
New	2-story SFR w/attached 3-car garage & semi-finished daylight basement...1997 UBC		2000
New	1999 Fleetwood Timberlake 66 x 27		2000
New	Tri level w/ 3 car		2000
New	1998 Redman M/4663B Wynnewood 28 x 66		2000
New	2 Story log home w/unfin bsmt		2000
New	27 -4 x 48 - 2000 - Redman		2000
New	One-story SFR		2000
New	66x27, 2000 Redman		2000
New	Approved Basic #00-100468 BP	Plan: 1008 Rambler Style SFR - 1997 UBC	2000
New	1995 Fleetwood Broadmore 48 x 14		2000
New	1999 Villa West 66 x 40		2000
New	2 Story w/ 3 Car		2000
New	New two story SFR with attached three car garage.		2000
New	Two Story SFR - 1994 UBC		2000
New	40 x 66 (1999) Silvercrest. Ref. 94-140340.		2000
New	1998 Zillacrest 28 x 66		2000
New	2-story SFR w/attached 3-car garage....1997 UBC		2000
New	2 story sfr w/3 car garage		2000
New	3087 sf 2-story w/854 sf garage and 212 sf covered deck/porch		2000
New	2-story SFR w/attached 2-car garage....1997 UBC		2000
New	Approved Basic #99-113971 BP	Plan: 1315 Split Level SFR - 1997 UBC	2000
New	Approved Basic #99-113971 BP	Plan: 1315 Split Level SFR - 1997 UBC	2000
New	SFR w/finished lower floor - 1997 UBC		2000
New	Approved Basic #99-113971 BP	Plan: 1315 Split Level SFR - 1997 UBC	2000
New	1200 sq ft SFR w/an attached 3500 sq ft garage.....1997 UBC		2000
New	Split w/fin basement & 3 Car		2000

Accessory Dwelling Units

Index # - File Name: 1.0022 - Single Family Dwellings Data\_Snohomish County.pdf

New	1705 sf rambler w/708 sf garage, and 30 sf covered deck/porch	2000
New	Rambler w/3-car garage.....1997 UBC	2000
New	Rambler style SFR.....1997 UBC	2000
New	Rambler style SFR w/attached 3-car garage.	2000
New	Rambler w/attached 3-car garage.....1997 UBC	2000
New	Rambler style SFR with attached garage	2000
New	2-story SFR w/attached 2-car garage by a covered breezeway.....1997 UBC	2000
New	Approved Basic #99-113971 BP Plan: 1315 Split Level SFR - 1997 UBC	2000
New	Approved Basic #99-113971 BP Plan: 1315 Split Level SFR - 1997 UBC	2000
New	Approved Basic #99-113971 BP Plan: 1315 Split Level SFR - 1997 UBC	2000
New	Approved Basic #99-113971 BP Plan: 1315 Split Level SFR - 1997 UBC	2000
New	Approved Basic #99-113971 BP Plan: 1315 Split Level SFR - 1997 UBC	2000
New	28 x 60 1984 Fleetwood	2000
New	2 story SFR with attached garage and covered porch	2000
New	2 story SFR with attached garage and covered porch.	2000
New	2 Story w/3 Car	2000
New	2 Story w/3 Car	2000
New	2 story SFR with attached garage	2000
New	Rambler Duplex w/attached 2-car garage per unit.....1997 UBC	2000
New	Approved Basic #99-113971 BP Plan: 1315 Split Level SFR - 1997 UBC	2000
New	Approved Basic #99-113971 BP Plan: 1315 Split Level SFR - 1997 UBC	2000
New	2-Story SFR w/attached garage.	2000
New	2000 Skyline Ambercove #6419 40 x 48	2000
New	2-story SFR w/attached 3-car garage.....1997 UBC	2000
New	1999 27 x 48 Goldenwest	2000
New	SFR over Garage.	2000
New	Two-story SFR w/attached garage	2000
New	2 Story w/Finished Basement, 3 Car Garage	2000
New	2 story SFR with semi-finished basement. Stop work ordered 1:42pm 10/4/00, Health District cl	2000
New	28 x 66 - 2000 - Lamplighter	2000
New	2804 sf 2-story w/641 sf garage, and 200 sf covered deck/porch	2000
New	Split level SFR w/attached 2-car garage.....1997 UBC	2000
New	Two Story SFR with Finished Basement and Attached Garage/Storage Area	2000
New	2-story SFR w/attached 2-car garage.....1997 UBC	2000
New	1964 s.f. rambler w/3 car garage	2001
New	27 x 48 2001 Greenbriar	2001
New	Two-story SFR w/semi-finished basement & attached garage	2001
New	2-story SFR.....1997 UBC	2001
New	1870 sf 2-story w/616 sf garage and 68 sf covered deck/porch	2001
New	2892 sf 2-story w/660 sf garage and 53 sf covered deck/porch	2001
New	Two-story SFR with attached garage -- 1997 UBC	2001
New	2440 sf w/2250 semi-finished basement, 576 sf garage, 60 sf covered deck/porch and 700 sf op	2001
New	Rambler with Attached Garage	2001
New	SFR with Finished Basement and Attached Garage	2001
New	4607 SF SFR W/3 car garage	2001
New	Two Story SFR with Garage	2001

Accessory Dwelling Units

Index # - File Name: 1.0022 - Single Family Dwellings Data\_Snohomish County.pdf

New	2002 Karsten 40x52		2001
New	36 x 40 Detached Accessory Apartment with attached carport		2001
New	Two-story SFR with attached garage - 1997 UBC		2001
New	One Story SFR with Finished Basement & 2 Car Garage		2001
New	2002 Marlette Elation		2001
New	40 x 44 SFR with attached garage - 1997 UBC		2001
New	Two-story SFR w/attached garage		2001
New	Approved Basic #99-113971 BP	Plan: 1315 Split Level SFR - 1997 UBC	2001
New	Approved Basic #01-103343 BP	Plan: TS-2303 Two Story SFR ....1997 UBC	2001
New	2 story sfr w/2 car garage		2001
New	2 story SFR with daylight basement and attached garage		2001
New	Two-story SFR w/attached garage		2001
New	2504 SF SFR W/Garage		2001
New	27 x 60 2000 Golden West Oakwood		2001
New	Approved Basic No. 01-103343 BP	Plan #TS-2303 Two Story SFR - 1997 UBC	2001
New	Two-story SFR w/attached garage		2001
New	Two Story SFR...1997 UBC		2001
New	1684 sf rambler w/1684 sf semi-finished basement, 440 sf garage, 33 sf covered porch and 200		2001
New	2609 2-story w/450 sf bonus room; w/815 sf garage and 220 sf covered deck/porch w/416 sf op		2001
New	Two-story SFR w/attached garage Bonus room over garage may only be semi-finished		2001
New	Two-story SFR with unfinished basement and attached garage -- 1997 UBC		2001
New	Rambler with Attached Garage		2001
New	Split Entry w/ 3 Car		2001
New	1998 28x66 Fleetwood. WORK CONT. ON 01-100621.		2001
New	2 story sfr w/unfinished basement		2001
New	2 story sfr w/2 car garage		2001
New	Approved Basic # 01-104109BP	Plan: 1236 Mid-Entry SFR - 1997 UBC	2001
New	Approved Basic #01-104109 BP	Plan: 1236 Mid Entry SFR - 1997 UBC	2001
New	Approved Basic #01-104109 BP	Plan: 1236 Mid Entry SFR - 1997 UBC	2001
New	Approved Basic #01-104109 BP	Plan: 1236 Mid Entry SFR - 1997 UBC	2001
New	Approved Basic #01-104109 BP	Plan: 1236 Mid Entry SFR - 1997 UBC	2001
New	3626 sf 2-story		2001
New	28x56, 1996 Marlette		2001
New	Split Level SFR with attached garage		2001
New	2-Story SFR		2001
New	Two Story SFR with Attached Garage		2001
New	2400 s.f. w/2400 s.f. finished basement & 700 s.f. garage		2001
New	2-story style SFR.....1997 UBC		2001
New	2925 sf 2-story w/830 sf garage and 58 sf covered deck/porch		2001
New	66 X 66 one-story SFR with attached garage - 1997 UBC		2001
New	2-story SFR w/attached 3-car garage...1997 UBC		2001
New	Two-story SFR w/attached garage		2001
New	1587 s.f. rambler		2001
New	New 2 story SFR w/semi finished basement & attached 2 car garage		2001
New	Approved Basic #01-105631 BP	Plan: 3219 Two Story Style SFR....1997 UBC	2001
New	Approved Basic #01-100583BP	Plan: 3162 Two Story SFR - 1997 UBC	2001
New	2001 Redman 27x56		2001

Accessory Dwelling Units

Index # - File Name: 1.0022 - Single Family Dwellings Data\_Snohomish County.pdf

New	28x66 1978 Redman		2001
New	SFR w/ Loft		2001
New	2 story SFR with unfinished basement, attached garage and covered porch		2001
New	28 x 66 1980 Fleetwood		2001
New	Fire Damage Repair		2001
New	Approved Basic 99-101299BP	Plan: #10 Mid-Entry With 2 Car - 1997 UI	2001
New	Rambler w/ 3 Car		2001
New	Rambler w/ 3 Car		2001
New	40 x 60 Kingswood 2001		2001
New	SFR w/unfinished basement - 1997 UBC		2001
New	SFR w/unfinished basement - 1997 UBC		2001
New	SFR w/unfinished basement - 1997 UBC		2001
New	SFR w/unfinished basement - 1997 UBC		2001
New	SFR w/unfinished basement - 1997 UBC		2001
New	SFR w/unfinished basement - 1997 UBC		2001
New	SFR w/unfinished basement - 1997 UBC		2001
New	SFR w/unfinished basement - 1997 UBC		2001
New	SFR w/unfinished basement - 1997 UBC		2001
New	Approved Basic #95-108526BP SFR w/unfinished basement	1994 UBC	2001
New	2805 SF SFR w/3 car garage		2001
New	Rambler style SFR with attached garage; covered porch and covered deck		2001
New	2 story SFR with attached garage		2001
New	774 SF Accessory Apartment		2001
New	Approved Basic #98-110504BP	Plan #2195 Split Level SFR - 1997 UBC	2001
New	2 story SFR w/ basement & attached 2 car garage		2001
New	Two-story SFR		2001
New	Convert existing 27x48, 1996 Oak Grove TD/MH to guest house		2001
New	27x66 2002 Greenbriar - 6351		2001
New	Rambler style SFR		2001
New	2182 sf one-story SFR with attached garage - 1997 UBC		2001
New	28x40 1988 OakMR		2001
New	Two-story SFR - 1997 UBC		2001
New	Rambler w/finished daylight basement.....1997 UBC		2001
New	2 story sfr with 3 car garage		2001
New	SFR with basement garage		2001
New	2755 sf 2-story /1008 sf garage and 320 sf covered deck/porch		2001
New	Two-story SFR w/attached garaged		2001
New	771 s.f. sfr w/771 s.f. unfinished basement		2001
New	12x48, 1968 Challenger GUEST HOUSE		2001
New	Two-story SFR w/attached garage		2001
New	1986 14x70 Fleetwood/Edgewood		2001
New	27x50 Marlett (2001)		2001
New	2056 Sf SFR		2001
New	1979 Glenbrook 24 x 60		2001
New	2 story SFR with garage as main floor and living space on top		2001
New	2-Story SFR w/finished attic & attached 3 car garage.		2001
New	3098 rambler w/1416 sf garage, and 459 sf covered deck/porch		2001

Accessory Dwelling Units

Index # - File Name: 1.0022 - Single Family Dwellings Data\_Snohomish County.pdf

New	30 x 59 Redman 4563B	2001
New	2 story sfr w/finished basement & 3 car garage	2001
New	2 story SFR with attached garage and covered porch	2001
New	2 Story w/ 2 Car	2001
New	2 Story SFR. Permit transferred from John Tonnes to Scott Bingham, 4/24/02.	2001
New	1020 sq ft Garage w/850 sq ft 2nd floor living space w/attached 480 sq ft Carport...1997 UBC	2001
New	2344 s.f. sfr w/703 s.f. unheated storage, 155 s.f. unheated sunroom, 3 car garage	2001
New	2 story sfr	2001
New	Approved Basic #01-105777 BP Plan: Julie Rambler Style SFR - 1997 UBC	2001
New	Opened for 1 time final inspection per A Husby 7/30/14 One-story SFR with semi-finished baser	2001
New	2 story SFR with unfinished basement and attached garage	2001
New	1588 sf 2-story w/324 sf garage and 16 sf covered entry	2001
New	1588 sf 2-story w/324 sf garage and 16 sf covered entry	2001
New	2 story sfr w/attached garage	2001
New	Two Story SFR - 1997 UBC	2001
New	28x66 1980 Statler	2001
New	2 story SFR with attached garage	2001
New	720sf detached accessory apartment with 1295sf garage/shop - 1997 UBC	2001
New	1977 24 x 60 Buckingham-Silvercrest	2001
New	28x68 2000 Marlette	2001
New	1729 sf 2-story w/736 sf basement and 178 sf open deck	2001
New	Approved Basic #01-111871 BP Rambler Style SFR - 1997 UBC	2001
New	Two Story SFR	2001
New	14 X 70 Fest 1986	2001
New	One-story SFR w/attached garage	2001
New	1 Story w/loft & 2 car garage	2001
New	1 story SFR w/attached 2 car garage	2001
New	1581 Sf SFR W/Garage	2001
New	2-story style SFR.....1997 UBC	2001
New	1996 28x48 Goldenwest	2001
New	2 story with attached garage 1997 UBC	2001
New	2321sf one-story SFR - 1997 UBC	2001
New	2958 sf Rambler w/905 sf finished basement, 844 sf garage, 85 sf covered deck/porch and 768 s	2001
New	12 x 60 1970 Skyline	2001
New	2-story style SFR.....1997 UBC	2001
New	2304 sf 2-story w/500 sf garage, and 236 sf covered deck/porch	2001
New	28x52 2001 Oakwood	2001
New	original permit and renewal have expired - new permit necessary per Dan Daley 11/02/05 SFR a	2001
New	2-Story SFR	2001
New	2002 40 x 66 Goldenwest	2001
New	Approved Basic #01-100636 BP Plan: GSC Duplex 1 Rambler Duplex 1997 UB	2001
New	1351 sf rambler w/1296 sf semifinished basement, 25 sf covered entry and 100 sf open deck - 1	2001
New	1180 SF SFR W/1335 SF Garage	2001
New	Approved Basic #00-111079 BP SFR w/finshed basement - 1997 UBC	2001
New	Rambler style SFR.....1997 UBC	2001
New	Split Level SFR with attached garage and covered porch	2001
New	Two Story SFR	2001



Accessory Dwelling Units

Index # - File Name: 1.0022 - Single Family Dwellings Data\_Snohomish County.pdf

New	27x62, 2001 Marlette		2001
New	1998 28 x 52 Palm Harbor		2001
New	2185 sf two-story SFR - 1997 UBC		2001
New	Conversion of 680 s.f. garage/shop to living space		2001
New	24 x52 (1979) Homet		2001
New	SFR		2001
New	Accessory apartment over detached garage		2001
New	Rambler Style SFR with attached garage		2001
New	Rambler w/ 3 Car		2001
New	3750 SF SFR W/Garage....1997 UBC	PLAN #8550-L	2001
New	Rambler style SFR.....197 UBC		2001
New	2257 SF SFR w/attached garage		2001
New	3411 2-story w/810 sf garage, 150 sf covered deck/porch, and 550 sf open deck		2001
New	SFR with finished basement and attached garage		2001
New	2 story sfr w/finished basement & 2 car garage		2001
New	Approved Basic #00-109792 BP	Plan: 2043 Rambler Style SFR - 1997 UBC	2001
New	SFR with Unfinished Basement and Attached Garage		2001
New	2001 Marlette 40x52		2001
New	SFR w/ attached garage & storage area above		2001
New	Convert Temporary Dwelling MH to Guest House		2001
New	Rambler style SFR with attached garage and covered porch		2001
New	Two Story SFR		2001
New	2 story SFR with attached garage and sunroom		2001
New	1810 sf split level w/840 sf finished basement, 465 sf garage and 270 sf open deck		2001
New	1986 Fleetwood 27 x 56		2001
New	28 x 52 - 2000 Goldenwest		2001
New	Two Story SFR - 1997 UBC		2001
New	Approved Basic #00-107353 BP	Two Story SFR - 1997 UBC	2001
New	Approved Basic #00-100468 BP	Plan: 1008 Rambler Style SFR - 1997 UBC	2001
New	Approved Basic #00-100468 BP	Plan: 1008 Rambler Style SFR - 1997 UBC	2001
New	Approved Basic #00-107353 BP	Two Story SFR - 1997 UBC	2001
New	Approved Basic #98-116988BP	Option approved:Main floor plan layout 2 story S	2001
New	27x42, 1998 Marlette		2001
New	24 x 60 Peerless Mobile Home		2001
New	Mid-entry SFR.....1997 UBC		2001
New	Rambler style Duplex.....1997 UBC		2001
New	One-story SFR w/unfin. bsmt & attached garage		2001
New	26x66 2001 Liberty		2001
New	Approved Basic #99-101683BP	SFR w/finshed basement - 1997 UBC	2001
New	Approved Basic #00-111079 BP	Plan: 1031C SFR w/finished lower floor - 19	2001
New	Two-story SFR w/attached garage		2001
New	Approved Basic #98-110058BP	Plan #1214/2 OPTION Approved: alt. upper floor	2001
New	Approved Basic #98-110058BP	Plan #1214/2 OPTION Approved: alt. upper floor	2001
New	Approved Basic #98-110058BP	Plan #1214/2 OPTION Approved: alt. upper floor	2001
New	Approved Basic #98-110058BP	Plan #1214/2 OPTION Approved: alt. upper floor	2001
New	714 sf 1st floor w/543 sf finished basement amd 400sf garae and 39 sf covered porch/deck		2001
New	27x54 2001 Oakwood/Goldenwest		2001

Accessory Dwelling Units

Index # - File Name: 1.0022 - Single Family Dwellings Data\_Snohomish County.pdf

New	2001 Goldenwest GE662F 28 x 66	2001
New	Convert existing shop on property to a 848 sq ft Detached Apartment...1997 UBC	2001
New	28 X 66 Golden West 2001	2001
New	25x50, 1996 Redman	2001
New	Approved Basic #01-103173 BP Plan No. 2471 Two-story style SFR.....1997 U	2001
New	24x40 1985 Fleetwood	2001
New	1500 sf SFR over garage - 1997 UBC	2001
New	1976 24 x 48 Sunrise	2001
New	EXPIRED WITHOUT COUNTY APPROVAL TO USE OR OCCUPY 2001 27x66 Goldenwest	2001
New	2000 Marlette 8227 66 x 40	2001
New	Approved Basic #01-110569 BP Plan: 1283 Split Level SFR - 1997 UBC	2001
New	Approved Basic #01-110569 BP Plan: 1283 Split Level SFR - 1997 UBC	2001
New	Approved Basic #01-110569 BP Plan: 1283 Split Level SFR - 1997 UBC	2001
New	2 story sfr with finished basement and 3 car garage. PERMIT TRANSFERRED TO MARK SHELLEY F	2001
New	40x66 2001 Liberty	2001
New	1903 sf Rambler w/612 sf garage, 366 sf covered porch/deck and 288 sf open deck	2001
New	1660 sf Rambler w/440 sf garage and 24 sf covered porch	2001
New	Split Level SFR - 1997 UBC Plan: #1283	2001
New	Rambler style SFR w/partial finished basement & semi-finished basement..1997 UBC	2001
New	1978 24 x 64 Hillcrest	2001
New	26 x 66 1991 Marlette #2706	2001
New	2676 sf 2-story DUPLEX w/940 sf garage and 48 sf covered porch	2001
New	2-story SFR w/covered porch on existing basement/foundation....1997 UBC	2001
New	One-story SFR w/attached garage	2001
New	28x64 1980 Fleetwood	2001
New	2-story SFR w/attached 3-car garage...1997 UBC	2001
New	60x28, 1979 Versailles	2001
New	One-story SFR w/attached garage	2001
New	2 story sfr	2001
New	2000 Palm Harbor 28x48	2001
New	Two-story SFR w/attached garage	2001
New	2001 Liberty 40 x 60	2001
New	1904 sf 2-story w/1176 sf unfinished basemnt and 480 sf covered deck/porch and 400 sf open d	2001
New	Approved Basic #98-108977BP Plan #1344 R Two Story SFR - 1997 UB	2001
New	27 x 66 2001 Golden West	2001
New	Two Story SFR with Attached Garage	2001
New	1985 27x40 Redman/SI6011AB	2001
New	Two-story SFR w/attached garage	2001
New	Rambler Style SFR - 1997 UBC	2001
New	1244sf one-story SFR with attached garage -- 1997UBC	2001
New	Rambler style SFR.....1997 UBC	2001
New	2001 Palm Harbor 4P364D4 27 x 64	2001
New	1344 s.f.w/648 s.f. finished basement & 2 car garage	2001
New	2849 SF SFR	2001
New	SFR with Attached Garage and 1490 SF Finished Basement and 568 SF Unfinished	2001
New	Two Story SFR with Attached Garage	2001
New	2 Story w/ attch d. 2 Car Garage	2001

Accessory Dwelling Units

Index # - File Name: 1.0022 - Single Family Dwellings Data\_Snohomish County.pdf

New	2982 SF Duplex		2001
New	Two-story SFR		2001
New	Approved Basic #99 103025 BP	Plan: 1450 S SFR w/finished basem	2001
New	2001 Silvercrest SV-57 52x27		2001
New	28 x 70 1985 Guerdon		2001
New	1536 SF SFR		2001
New	2 story sfr w/3 car garage		2001
New	2845 sf 2-story w/816 sf garage, 35 sf covered porch and 120 sf patio		2001
New	1999 Marlette 8220 Pacifica 40 x 60		2001
New	2311 sq. ft. SFR		2001
New	2-story SFR.....1997 UBC		2001
New	2-story style SFR.....1997 UBC		2001
New	2-story SFR w/semi-finished basement.....1997 UBC		2001
New	2934 2-story w/737 sf garage, 84 sf covered proch and 144 sf open deck		2001
New	54 x 68 One-story SFR with attached garage - 1997 UBC		2001
New	24 x 64 1978 Bayfront		2001
New	2634 Sf SFR w/garage		2001
New	2001 41 x 66 Oakwood		2001
New	40 x 56 - 1993 - Marlette		2001
New	2001 Palm Harbor 3V471A2		2001
New	3581sf one-story SFR with attached 1200sf garage - 1997 UBC		2001
New	2 Story SFR - 1997 UBC		2001
New	40x64 2001 Marlette - Pacifica		2001
New	1740 Sq Ft SFR with 934 Sq Ft Unfinished Basement and Attached Garage		2001
New	Rambler Style SFR - 1997 UBC		2001
New	3-story style SFR w/attached 3-car garage by a breezeway....1997 UBC		2001
New	Approved Basic #01-106206 BP	Plan: 1144 Rambler Style SFR - 1997 UBC	2001
New	Approved Basic #00- 110357 BP	Plan: Duplex 1219-2 - Crawl Space	2001
New	Single story detached accessory apartment....1997 UBC		2001
New	Two Story SFR with Attached Garage		2001
New	1756 sf rambler w/1644 sf semi-finished basement, 616 sf garage & 606 sf covered deck/porcl		2001
New	45 x 49 Two-story SFR with attached garage - 1997 UBC		2001
New	36 x 50 Two-story SFR with attached garage		2001
New	1988 28 x 60 American Mansion		2001
New	Approved Basic #98-110213BP	Plan #1333 Two Story Duplex - 19	2001
New	1090 sf 2-story w/27 sf covered deck/porch and 280 sf open deck		2001
New	2-Story over unfinished daylight basement SFR w/attached garage.		2001
New	27x48, 1987 Lamplighter		2001
New	1998 Palm Harbour 564 28 x 64		2001
New	2 story SFR with unfinished daylight basement		2001
New	2-story house w/unfinished daylight basement & attached 2-car garage....1997 UBC		2001
New	Two-story SFR w/attached		2001
New	Straight Arrow Construction transferred to Kyle Herman Smith 7/5/2002	Approved Basic #01-1	2001
New	3512 sf 2-story w/1020 sf garage, and 156 sf covered dec/porch		2001
New	2-story style detached accessory apartment...1997 UBC		2001
New	48x42 (2001) Skyline		2001
New	singed off by M. McCrary 27 x 58	2001 Marlette	2001

Accessory Dwelling Units

Index # - File Name: 1.0022 - Single Family Dwellings Data\_Snohomish County.pdf

New	28x66		2001
New	Two Story SFR with Attached Garage		2001
New	SFR w/semi-finished daylight basement		2001
New	2-story style SFR....1997 UBC		2001
New	2 story SFR with attached garage		2001
New	48 X 24 Fleetwood 1982		2001
New	1134 sf Rambler w/652 sf finished basement, 462 sf garage, 32 sf covered deck/ porch, and 72 sf		2001
New	Rambler style SFR w/semi-finished basement & office on 2nd floor....1997 UBC		2001
New	Mid-entry style SFR.....1997 UBC		2001
New	Two-story SFR - 1997 UBC		2001
New	Approved Basic #98-108977BP	Plan #1344 R Two Story SFR - 1997 UBC	2001
New	2 story SFR with unfinished lower floor and attached garage, covered porch and deck		2001
New	One-story SFR		2001
New	5040 sf Rambler w/760 sf covered deck/porch		2001
New	2-story SFR.....1997 UBC		2001
New	1977 28 x 68 Sunnybrook		2001
New	Log Home with loft		2001
New	Approved Basic #98-110213BP	Plan #1333 Two Story Duplex - 1997 UBC	2001
New	Approved Basic #98-110231BP	Plan: Rutledge 1365 One-story SFR w/finished	2001
New	Two Story SFR with Finished Basement and Attached Garage		2001
New	12 x 60 1968 Facitica		2001
New	624 sf 2nd floor SFR w/624 1st floor garage		2001
New	14x64 (1981) Kentwood		2001
New	147x73 SFR w/Garage		2001
New	2001 Silver Crest 28 x 56		2001
New	24 x 60 1978 Hillcrest. NON-OCC POSTED BY CHRIS GRIFFITH, 1/15/03.		2001
New	Approved Basic #01-110518BP	Plan: 1587 SFR w/finished lower floor - 1997 UBC	2001
New	Two-story SFR w/finished basement & attached garage		2001
New	2-story style SFR w/3-car garage....1997 UBC		2001
New	2 story SFR w/ attached 2 car garage		2001
New	Rambler w/ daylight basement		2001
New	1999 27 x 38 Greenbrier		2001
New	2400 sf 2-story w/735 sf garage and 144 sf covered deck/porch		2001
New	54 X 40 Desert Manor 2001		2001
New	Two Story SFR with Attached Garage		2001
New	1301 s.f. Rambler w/2 car garage - 1997 UBC		2001
New	14 x 70 - 1980 - Fleetwood		2001
New	14 x 70 - 1978 - Liberty		2001
New	26 8 x 56 2001 Marlette		2001
New	Two-story SFR w/attached garage		2001
New	Two Story SFR with Attached Garage		2001
New	Two-story SFR with attached garage - 1997.		2001
New	Split Level with attached garage and covered porch		2001
New	Approved Basic #01-103343 BP	Plan: TS-2303 Two Story SFR ....1997 UBC	2001
New	Two Story SFR - 1997 UBC		2001
New	2-story SFR w/attached 3-car garage....1997 UBC		2001
New	Park office and managers mobile home		2001

Accessory Dwelling Units

Index # - File Name: 1.0022 - Single Family Dwellings Data\_Snohomish County.pdf

New	Approved Basic #01-111403 BP	Plan 2274/Rev	Rambler Style SFR - 1997 UBC	2001
New	2 Story SFR with attached garage			2001
New	Two Story SFR with Attached Garage			2001
New	5521 SF SFR w/3 car garage			2001
New	3250 sf 2-story w/906 sf garage			2001
New	14 x 52 1977 single wide			2001
New	Rambler w/attached 2-car garage.....1997 UBC			2001
New	27x40 (2001) Marlette			2001
New	38 x 46 two-story SFR with attached garage -- 1997 UBC			2001
New	Two Story SFR			2001
New	23.5 x 34 Garage w/SFR on 2nd floor...1997 UBC			2001
New	Rambler style SFR w/attached storage.....1997 UBC			2001
New	27 x 44 2000 Marlette			2001
New	New SFR.			2001
New	Rambler style SFR w/studio on 2nd floor w/attached 2-car garage...1997 UBC			2001
New	Two Story SFR with Attached Garage and Finished Basement			2001
New	2-story style SFR.....1997 UBC			2001
New	Approved Basic #99-100561BP	Two Story SFR - 1997 UBC	Plan #48	2001
New	2-story style SFR w/unfinished basement/storage & 3-car garage....1997 UBC			2001
New	2-story style SFR.....1997 UBC			2001
New	Quad w/ 3 Car			2001
New	Two Story SFR with Semi-Finished Basement and Attached Garage			2001
New	2 story SFR with daylight basement and attached garage			2001
New	2 Story w/ 2 Car & Basement Garage			2001
New	1400sf mid-entry SFR - 1997 UBC			2001
New	Two-story SFR with attached garage - 1997 UBC			2001
New	Approved Basic #98-106424BP	Plan #8230	Two Story SFR - 1994	2001
New	2-story style SFR.....1997 UBC			2001
New	Approved Basic #00-107844 BP	Plan: #2327 w/basement	Two Story SFR w/unf	2001
New	Approved Basic #99-105402 BP	Plan: 2650 A/3 SG	Two Story SFR - 1997 UBC	2001
New	2556 2-stroy w/876 sf garage and 36 sf covered deck/porch			2001
New	2609 sf 2-story w/794 sf garage, 52 sf covered deck/porch and 168 sf patio			2001
New	2-Story SFR w/attached garage			2001
New	2-story SFR w/3-car garage....1997 UBC			2001
New	Approved Basic #01-105751 BP	Two Story Duplex.....1997 UBC		2001
New	Rambler style SFR.....1997 UBC			2001
New	Rambler w/ 3 Car			2001
New	1643 sf rambler and 1371 sf garage			2001
New	1438 sf 2-story cabin			2001
New	2 story sfr w/2 car garage & 2925 s.f. attached shop			2001
New	14 x 60 1985 Champion			2001
New	840 sf Accessory Apt with 638 sf garage and 406 sf carport - 1997 UBC			2001
New	Two-story SFR w/attached garage			2001
New	Two Story SFR with Attached Garage			2001
New	Rambler w/finished basement & shop.....1997 UBC			2001
New	Approved Basic #98-150644BP	Builders Plan: Charlene	Two story sfr wi	2001
New	1168 sf rambler w/720 sf finished basement, 432 sf garage, and 150 sf covered deck/porch			2001

Accessory Dwelling Units

Index # - File Name: 1.0022 - Single Family Dwellings Data\_Snohomish County.pdf

New	Rambler style SFR.....1997 UBC. Permit transferred to Deierling from Erwin Homes, 7/5/02. g	2001
New	2 Story SFR w/loft.....1997 UBC	2001
New	Two-story SFR w/attached garage	2001
New	40x66, 2001 Oakwood Classic	2001
New	Two story SFR w/attached garage	2001
New	Approved Basic No. 01-104105 BP Bldrs Plan No. 668 Split Level SFR.....1	2001
New	2-story SFR w/covered Porch.....1997 UBC	2001
New	Approved Basic #01-104372 BP Plan: The Stoneybrook Two Story SFR - 1997 UBC	2001
New	1548 sf rambler w/384 sf garage and 56 sf open deck	2001
New	Two-story SFR with attached garage - 1997 UBC	2001
New	Two-story SFR w/attached garage - 1997 UBC	2001
New	2-story SFR.....1997 UBC	2001
New	2340 SF SFR W/Garage....1997UBC.....Builders Plan # INABNIT	2001
New	Approved Basic #99-110065-BP Bldrs Plan # 7360. 2-Story SFR w/attached 3	2001
New	Approved Basic #99-109701 BP Builder Plan # 7856 Two Story SFR - 19	2001
New	Approved Basic #99-109701 BP Builder Plan # 7856 Two Story SFR - 19	2001
New	2550 sf 2-story w/702 sf garage, 10 sf covered proch and 200 sf patio	2001
New	Approved Basic #99-105402BP Plan: 2650 A/3 SG Two Story SFR - 199	2001
New	2-story style SFR.....1997 UBC	2001
New	Approved Basic #99-105400BP Plan: 245513 Two Story SFR - 1997 UB	2001
New	Approved Basic #01-112472 BP Plan: 2D Side Load Rambler Style SFR - 1997 U	2001
New	Two Story SFR - 1997 UBC	2001
New	Approved Basic #99-109698 BP Builder Plan # 7840-A w/Bonus Rm Two Story SFR - 199	2001
New	Approved Basic #99-110065-BP Bldrs Plan # 7360. Two Story SFR - 1997 UB	2001
New	Approved Basic #99-109701 BP Plan # 7856 Two Story SFR - 1997 UBC	2001
New	Approved Basic #99-110420 BP Bldrs Plan 8230-A 2-Story SFR w/attache	2001
New	Approved Basic # 01-107550 BP Plan Name: 1715 S Mid-entry style SFR.....1997 U	2001
New	Approved Basic #01-105456 BP Plan: 2650A-DB/3SG Two-story SFR with unfir	2001
New	Approved Basic #99-110065-BP Bldrs Plan # 7360. 2-Story SFR w/attached 3	2001
New	27x66 2001 Skyline Greenbrier 6303	2001
New	Approved Basic 00-102136BP Rambler Style SFR - 1997 UBC	2001
New	Rambler Style SFR - 1997 UBC	2001
New	Approved Basic #99-109807 BP Plan: 2768 Two Story SFR - 1997 UBC Of	2001
New	Approved Basic #01-113048 BP Plan :2064 Two Story SFR - 1997 UBC	2001
New	Approved Basic #01-108121 BP Plan: Shreveport/3SG Two Story SFR - 1997 UBC	2001
New	Two-story SFR - 1997 UBC Builder s Plan 2064	2001
New	Approved Basic No. 01-103348 BP Bldrs Plan No. 2511 2-story style SFR.....19	2001
New	2 Story w/3 Car	2001
New	Two-story SFR - 1997 UBC Builder s Plan 2064	2001
New	Two-story SFR w/attached garage	2001
New	Two-story SFR w/attached garage	2001
New	Two-story SFR w/attached garage	2001
New	Two-story SFR w/attached garage	2001
New	Approved Basic #01-104132 BP Plan: 2895 Two Story SFR - 1997 UBC	2001
New	Approved Basic #01-104132 BP Plan: 2895 Two Story SFR - 1997 UBC	2001
New	Approved Basic No. 01-103350 BP Bldrs Plan No. 2990 2-story style SFR.....19	2001
New	Approved Basic #01-103350 BP Bldrs Plan No. 2990 Two-story style SFR.....19	2001

Accessory Dwelling Units

Index # - File Name: 1.0022 - Single Family Dwellings Data\_Snohomish County.pdf

New	Approved Basic #99-113027 BP	Plan: 2621	Two Story SFR - 1997 U	2001
New	Approved Basic #99-110535 BP	Plan: 2834	Two Story SFR - 1997 UBC	2001
New	Approved Basic #99-110535 BP	Plan: 2834	Two Story SFR - 1997 UBC 1st Opti	2001
New	Two Story SFR - 1997 UBC	Plan: 2892		2001
New	Two Story SFR with Finished Basement	ERROR ON ORIGINAL PERMIT, Floor square footage tra		2001
New	3007sf two-story SFR with attached garage --	1997 UBC		2001
New	2492 sf rambler w/720 sf garage and 32 sf covered deck/porch			2001
New	2 story SFR with attached garage			2001
New	2330 sf 2-story w/660 sf garage and 580 sf covered deck/porch			2001
New	Approved Basic #98-108977BP	Plan #1344 R	Two Story SFR - 1997 UB	2001
New	2-story style SFR w/attached 3-car garage...	1997 UBC		2001
New	40 X 56	1999 Oakwood		2001
New	Rambler style SFR.....	1997 UBC		2001
New	1741 sf 2-story w/484 sf garage and 51 sf covered deck/porch and 100 sf open deck			2001
New	Approved Basic #01-110569 BP	Plan: 1283	Split Level SFR - 1997 UBC	2001
New	2-Story SFR w/attached Garage			2001
New	2 story sfr w/3 car garage			2001
New	Two Story SFR - 1997 UBC			2001
New	Two Story SFR - 1997 UBC			2001
New	Approved Basic #99-114150 BP	Plan: 5622 w/bonus	Two Story SFR - 1997 UBC	2001
New	Approved Basic #98-107691BP	Option Approved: 3rd car bay	Two Story SFR - 1997 UBC	2001
New	Approved Basic #98-107691BP	Option Approved: 3rd car bay	Two Story SFR - 1997 UBC	2001
New	2 story sfr w/3 car garage			2001
New	2 story SFR w/attached garage			2001
New	Rambler style SFR.....	1997 UBC		2001
New	2001 Oakwood	28 x 66		2001
New	One-story SFR w/attached garage			2001
New	Two Story SFR - 1997 UBC	Plan: 2539 Elev. C (side load)		2001
New	Two Story SFR - 1997 UBC	Plan: 5218/5318		2001
New	Two Story SFR - 1997 UBC	Plan: 4002		2001
New	Two Story SFR - 1997 UBC			2001
New	5/30/01 - STOP WORK ORDER ISSUED AT 1:38 P.M. BY GERRY SCHELBRACK.	2-story style SFR...		2001
New	Two Story SFR - 1997 UBC			2001
New	Two Story SFR - 1997 UBC	Plan: RH2-18		2001
New	Two Story SFR - 1997 UBC			2001
New	Two Story SFR - 1997 UBC			2001
New	Two Story SFR - 1997 UBC			2001
New	Two Story SFR - 1997 UBC			2001
New	Two Story SFR - 1997 UBC			2001
New	Two Story SFR - 1997 UBC	Plan: 5023/5123 w/bonus rm		2001
New	Two Story SFR - 1997 UBC			2001
New	Two Story SFR - 1997 UBC			2001
New	Two Story SFR - 1997 UBC			2001
New	Two Story SFR - 1997 UBC			2001
New	2-story style SFR.....	1997 UBC		2001
New	Two Story SFR - 1997 UBC			2001
New	Approved Basic #00-109999 BP	Plan: 2063 A-1	Rambler Style SFR - 1997 UBC	2001

Accessory Dwelling Units

Index # - File Name: 1.0022 - Single Family Dwellings Data\_Snohomish County.pdf

New	One-story SFR w/above grade basement/garage		2001
New	Rambler style SFR with attached garage		2001
New	27 x 51 2001 Palm Harbor		2001
New	Two Story SFR - 1997 UBC	Plan: 1446	2001
New	Approved Basic #01-105743 BP	Plan: 1644 crawl Split Level SFR - 1997 UBC	2001
New	Two Story SFR - 1997 UBC	Plan: 1444	2001
New	Approved Basic #00-106811 BP	Plan: 1644 slab/revised Split Level SFR - 1997 UI	2001
New	Approved Basic #01-106982 BP	Plan: 1705 crawl (revised) SFR w/finished lo	2001
New	Approved Basic #00-106811 BP	Plan: 1644 slab/revised Split Level SFR - 1997 UI	2001
New	Approved Basic #00-106811 BP	Plan: 1644 slab/revised Split Level SFR - 1997 UI	2001
New	Approved Basic #00-106367 BP	Plan: 1705 crawl SFR w/finished lower floor	2001
New	Approved Basic #01-105743 BP	Plan: 1644 crawl Split Level SFR - 1997 UBC	2001
New	Approved Basic #01-106982 BP	Plan: 1705 crawl (revised) SFR w/finished lo	2001
New	Approved Basic #01-105743 BP	Plan: 1644 crawl Split Level SFR - 1997 UBC	2001
New	Approved Basic #01-105023 BP	Plan: 1391 Two Story SFR - 1997 UBC	2001
New	Approved Basic #01-105212 BP	Plan: 1538 Two Story SFR - 1997 UBC	2001
New	Approved Basic #01-105212 BP	Plan: 1538 Two Story SFR - 1997 UBC	2001
New	Approved Basic #01-105212 BP	Plan: 1538 Two Story SFR - 1997 UBC	2001
New	Approved Basic #01-105023 BP	Plan: 1391 Two Story SFR - 1997 UBC	2001
New	Approved Basic #01-105212 BP	Plan: 1538 Two Story SFR - 1997 UBC	2001
New	Approved Basic #01-105212 BP	Plan: 1538 Two Story SFR - 1997 UBC	2001
New	Approved Basic #01-105212 BP	Plan: 1538 Two Story SFR - 1997 UBC	2001
New	Approved Basic #01-105023 BP	Plan: 1391 Two Story SFR - 1997 UBC	2001
New	Approved Basic #01-105212 BP	Plan: 1538 Two Story SFR - 1997 UBC	2001
New	Approved Basic #01-105023 BP	Plan: 1391 Two Story SFR - 1997 UBC	2001
New	Approved Basic #01-105212 BP	Plan: 1538 Two Story SFR - 1997 UBC	2001
New	Approved Basic #01-105023 BP	Plan: 1391 Two Story SFR - 1997 UBC	2001
New	Approved Basic #01-105212 BP	Plan: 1538 Two Story SFR - 1997 UBC	2001
New	Approved Basic #00-110871 BP	Plan: 556 Two Story SFR - 1997 UBC	2001
New	28 x 66 1999 Goldenwest		2001
New	Approved Basic #01-106755 BP	Plan: 704 - revised Two Story SFR - 1997 UBC	2001
New	Approved Basic #01-106753 BP	Plan: 702 revised Two Story SFR - 1997 UBC	2001
New	Two Story SFR - 1997 UBC	Plan: 703	2001
New	Approved Basic #00-110871 BP	Plan: 556 Two Story SFR - 1997 UBC	2001
New	Approved Basic #00-110868 BP	Plan: 553 Two Story SFR - 1997 UBC	2001
New	Approved Basic #00-109216 BP	Plan: 455 Two Story SFR - 1997 UBC	2001
New	Approved Basic #00-109214 BP	Plan: 454 Two Story SFR - 1997 UBC	2001
New	Approved Basic #00-109218 BP	Plan: 453 Two Story SFR - 1997 UBC	2001
New	Approved Basic #00-109215 BP	Plan: 456 Two Story SFR - 1997 UBC	2001
New	Approved Basic #00-109217 BP	Plan: 451 Two Story SFR - 1997 UBC	2001
New	Approved Basic #00-109218 BP	Plan: 453 Two Story SFR - 1997 UBC	2001
New	Approved Basic #00-109216 BP	Plan: 455 Two Story SFR - 1997 UBC	2001
New	Approved Basic #00-109218 BP	Plan: 453 Two Story SFR - 1997 UBC	2001
New	Approved Basic #00-109217 BP	Plan: 451 Two Story SFR - 1997 UBC	2001
New	Approved Basic #00-109214 BP	Plan: 454 Two Story SFR - 1997 UBC	2001
New	Approved Basic #00-109217 BP	Plan: 451 Two Story SFR - 1997 UBC	2001
New	Approved Basic #00-109220 BP	Plan: 452 Two Story SFR - 1997 UBC	2001



Accessory Dwelling Units

Index # - File Name: 1.0022 - Single Family Dwellings Data\_Snohomish County.pdf

New	Approved Basic #00-109216 BP	Plan: 455 Two Story SFR - 1997 UBC	2001
New	Approved Basic #00-109215 BP	Plan: 456 Two Story SFR - 1997 UBC	2001
New	Approved Basic #00-109220 BP	Plan: 452 Two Story SFR - 1997 UBC	2001
New	Approved Basic #00-109214 BP	Plan: 454 Two Story SFR - 1997 UBC	2001
New	Approved Basic #00-109218 BP	Plan: 453 Two Story SFR - 1997 UBC	2001
New	Approved Basic #00-109216 BP	Plan: 455 Two Story SFR - 1997 UBC	2001
New	Approved Basic #00-109215 BP	Plan: 456 Two Story SFR - 1997 UBC	2001
New	Approved Basic #00-109215 BP	Plan: 456 Two Story SFR - 1997 UBC	2001
New	Approved Basic #00-109217 BP	Plan: 451 Two Story SFR - 1997 UBC	2001
New	Approved Basic #00-109220 BP	Plan: 452 Two Story SFR - 1997 UBC	2001
New	Approved Basic #00-109218 BP	Plan: 453 Two Story SFR - 1997 UBC	2001
New	Approved Basic #00-109216 BP	Plan: 455 Two Story SFR - 1997 UBC	2001
New	Approved Basic #00-109214 BP	Plan: 454 Two Story SFR - 1997 UBC	2001
New	Approved Basic #00-109215 BP	Plan: 456 Two Story SFR - 1997 UBC	2001
New	Approved Basic #00-109218 BP	Plan: 453 Two Story SFR - 1997 UBC	2001
New	Approved Basic #00-109220 BP	Plan: 452 Two Story SFR - 1997 UBC	2001
New	Approved Basic #00-109216 BP	Plan: 455 Two Story SFR - 1997 UBC	2001
New	Approved Basic #00-109218 BP	Plan: 453 Two Story SFR - 1997 UBC	2001
New	Approved Basic #00-109220 BP	Plan: 452 Two Story SFR - 1997 UBC	2001
New	Approved Basic #00-109214 BP	Plan: 454 Two Story SFR - 1997 UBC	2001
New	Approved Basic #00-109217 BP	Plan: 451 Two Story SFR - 1997 UBC	2001
New	Approved Basic #00-109216 BP	Plan: 455 Two Story SFR - 1997 UBC	2001
New	Approved Basic #00-109215 BP	Plan: 456 Two Story SFR - 1997 UBC	2001
New	Approved Basic #00-109220 BP	Plan: 452 Two Story SFR - 1997 UBC	2001
New	Approved Basic #00-109218 BP	Plan: 453 Two Story SFR - 1997 UBC	2001
New	Approved Basic #00-109214 BP	Plan: 454 Two Story SFR - 1997 UBC	2001
New	Approved Basic #00-109215 BP	Plan: 456 Two Story SFR - 1997 UBC	2001
New	Approved Basic #00-109216 BP	Plan: 455 Two Story SFR - 1997 UBC	2001
New	Approved Basic #00-109220 BP	Plan: 452 Two Story SFR - 1997 UBC	2001
New	Approved Basic #00-109214 BP	Plan: 454 Two Story SFR - 1997 UBC	2001
New	Approved Basic #98-110213BP	Plan #1333 Two Story Duplex - 19	2001
New	Approved Basic #00-110869 BP	Plan: 554 Two Story SFR - 1997 UBC	2001
New	Approved Basic #00-110867 BP	Plan: 552 Two Story SFR - 1997 UBC	2001
New	Approved Basic #00-110871 BP	Plan: 556 Two Story SFR - 1997 UBC	2001
New	Approved Basic #00-110869 BP	Plan: 554 Two Story SFR - 1997 UBC	2001
New	Approved Basic #00-110870 BP	Plan: 555 Two Story SFR - 1997 UBC	2001
New	Approved Basic #00-110869 BP	Plan: 554 Two Story SFR - 1997 UBC	2001
New	Approved Basic #00-110870 BP	Plan: 555 Two Story SFR - 1997 UBC	2001
New	Approved Basic #00-110867 BP	Plan: 552 Two Story SFR - 1997 UBC	2001
New	Approved Basic #00-110871 BP	Plan: 556 Two Story SFR - 1997 UBC	2001
New	Approved Basic #00-110868 BP	Plan: 553 Two Story SFR - 1997 UBC	2001
New	Approved Basic #00-110867 BP	Plan: 552 Two Story SFR - 1997 UBC	2001
New	Approved Basic #00-110868 BP	Plan: 553 Two Story SFR - 1997 UBC	2001
New	Approved Basic #00-110867 BP	Plan: 552 Two Story SFR - 1997 UBC	2001
New	Approved Basic #01-105838 BP	Plan: 554 R Two Story SFR.....1997 UBC	2001
New	Approved Basic #01-105842 BP	Plan: 555 R Two Story SFR.....1997 UBC	2001
New	Approved Basic #00-110867 BP	Plan: 552 Two Story SFR - 1997 UBC	2001

Accessory Dwelling Units

Index # - File Name: 1.0022 - Single Family Dwellings Data\_Snohomish County.pdf

New	Approved Basic #00-110868 BP	Plan: 553 - revised Two Story SFR - 1997 UBC	2001
New	Approved Basic #01-105843 BP	Plan: 556 R Two style SFR.....1997 UBC	2001
New	Approved Basic #01-105838 BP	Plan: 554 R Two Story SFR.....1997 UBC	2001
New	Approved Basic #00-110867 BP	Plan: 552 Two Story SFR - 1997 UBC	2001
New	Approved Basic #01-105842 BP	Plan: 555 R Two Story SFR.....1997 UBC	2001
New	Approved Basic #01-105843 BP	Plan: 556 R Two style SFR.....1997 UBC	2001
New	Approved Basic #01-105838 BP	Plan: 554 R Two Story SFR.....1997 UBC	2001
New	Approved Basic #01-105842 BP	Plan: 555 R Two Story SFR.....1997 UBC	2001
New	Approved Basic #01-105843 BP	Plan: 556 R Two style SFR.....1997 UBC	2001
New	2 story w/3 car garage		2001
New	Approved Basic #01-105842 BP	Plan: 555 R Two Story SFR.....1997 UBC	2001
New	Approved Basic #01-105838 BP	Plan: 554 R Two Story SFR.....1997 UBC	2001
New	Approved Basic #01-105838 BP	Plan: 554 R Two Story SFR.....1997 UBC	2001
New	Approved Basic #00-110867 BP	Plan: 552 Two Story SFR - 1997 UBC	2001
New	Approved Basic #00-110868 BP	Plan: 553 - revised Two Story SFR - 1997 UBC	2001
New	Approved Basic #00-110867 BP	Plan: 552 Two Story SFR - 1997 UBC	2001
New	Approved Basic #00-110868 BP	Plan: 553 - revised Two Story SFR - 1997 UBC	2001
New	Approved Basic #01-105842 BP	Plan: 555 R Two Story SFR.....1997 UBC	2001
New	Approved Basic #01-106757 BP	Plan: 706 - revised Two Story SFR - 1997 UBC	2001
New	Approved Basic #01-106754 BP	Plan: 703 - revised Two Story SFR - 1997 UBC	2001
New	Approved Basic #01-103984 BP	Plan: 706 Two Story SFR - 1997 UBC	2001
New	Approved Basic #01-103987 BP	Plan: 705 Two Story SFR - 1997 UBC	2001
New	Approved Basic #01-103986 BP	Plan: 704 Two Story SFR - 1997 UBC	2001
New	Approved Basic #01-103984 BP	Plan: 706 Two Story SFR - 1997 UBC	2001
New	Approved Basic #01-103985 BP	Plan: 702 Two Story SFR - 1997 UBC	2001
New	Approved Basic #01-103983 BP	Plan: 703 Two Story SFR - 1997 UBC	2001
New	Approved Basic #01-103985 BP	Plan: 702 Two Story SFR - 1997 UBC	2001
New	Approved Basic #01-106755 BP	Plan: 704 - revised Two Story SFR - 1997 UBC	2001
New	Approved Basic #01-106754 BP	Plan: 703 - revised Two Story SFR - 1997 UBC	2001
New	Approved Basic #01-106757 BP	Plan: 706 - revised Two Story SFR - 1997 UBC	2001
New	Approved Basic #01-106753 BP	Plan: 702 revised Two Story SFR - 1997 UBC	2001
New	Approved Basic #01-106753 BP	Plan: 702 revised Two Story SFR - 1997 UBC	2001
New	Approved Basic #01-106754 BP	Plan: 703 - revised Two Story SFR - 1997 UBC	2001
New	Approved Basic #01-103986 BP	Plan: 704 Two Story SFR - 1997 UBC	2001
New	Approved Basic #01-103987 BP	Plan: 705 Two Story SFR - 1997 UBC	2001
New	Approved Basic #01-103983 BP	Plan: 703 Two Story SFR - 1997 UBC	2001
New	Approved Basic #01-103984 BP	Plan: 706 Two Story SFR - 1997 UBC	2001
New	Approved Basic #01-103987 BP	Plan: 705 Two Story SFR - 1997 UBC	2001
New	Approved Basic #01-103984 BP	Plan: 706 Two Story SFR - 1997 UBC	2001
New	Approved Basic #01-103983 BP	Plan: 703 Two Story SFR - 1997 UBC	2001
New	Approved Basic #01-103985 BP	Plan: 702 Two Story SFR - 1997 UBC	2001
New	Approved Basic #01-103986 BP	Plan: 704 Two Story SFR - 1997 UBC	2001
New	Approved Basic #01-103983 BP	Plan: 703 Two Story SFR - 1997 UBC	2001
New	Approved Basic #01-103985 BP	Plan: 702 Two Story SFR - 1997 UBC	2001
New	Approved Basic #01-103987 BP	Plan: 705 Two Story SFR - 1997 UBC	2001
New	Approved Basic #01-103983 BP	Plan: 703 Two Story SFR - 1997 UBC	2001
New	Two Story SFR - 1997 UBC	Plan: 706	2001

Accessory Dwelling Units

Index # - File Name: 1.0022 - Single Family Dwellings Data\_Snohomish County.pdf

New	Rambler Style SFR - 1997 UBC		2001
New	Apprvped Basic #01-112509 BP	Plan: 3210 E Conventional Two Story SFR - 1997 UBC	2001
New	Approved Basic #99-112585 BP	Builders Plan 3105 D Two Story SFR -	2001
New	SFR W/Garage		2001
New	2420sf one-story SFR with 872sf attached garage - 1997 UBC	Bldr s Plan R2420B3G3	2001
New	40x66, 2001 Golden West		2001
New	2001 Marlette River Crest 9599 26 x 44		2001
New	Rambler SFR - 1997 UBC		2001
New	Rambler Style SFR - 1997 UBC		2001
New	Rambler Style SFR - 1997 UBC		2001
New	STOP WORK posted 12/11/01 @1:30pm. ds	Approved Basic #01-100508 BP Plan: ES/	2001
New	Two-story SFR with attached garage - 1997 UBC		2001
New	Two-story SFR with attached garage - 1997 UBC		2001
New	Approved Basic #00-104229 BP	Plan: 1533 revised Two Story SFR - 1997 UE	2001
New	Approved Basic #00-104229 BP	Plan: 1533 revised Two Story SFR - 1997 UE	2001
New	Approved Basic #00-104229 BP	Plan: 1533 revised Two Story SFR - 1997 UE	2001
New	2 Story SFR		2001
New	Approved Basic #00-103206 BP	Plan: 1528 Rambler Style SFR - 1997 UBC	2001
New	Approved Basic #00-103206 BP	Plan: 1528 Rambler Style SFR - 1997 UBC	2001
New	1572 SF SFR w/3 car garage.....1997 UBC	Bldr s Plan #1572	2001
New	Approved Basic #01-105378 BP	Plan 1721 Rambler style SFR.....1997 UBC	2001
New	1721 sf rambl er w/682 sf garage and 154 sf covered deck/porch - 1997 UBC	Builder s Plan # 17	2001
New	Rambler style SFR with attached garage		2001
New	Approved Basic #01-105377 BP	Plan: 1572 Rambler style SFR....1997 UBC	2001
New	Approved Basic #01-105377 BP	Plan: 1572 Rambler style SFR....1997 UBC	2001
New	Approved Basic #01-105378 BP	Plan 1721 Rambler style SFR.....1997 UBC	2001
New	Approved Basic #01-105378 BP	Plan 1721 Rambler style SFR.....1997 UBC	2001
New	Approved Basic #01-105377 BP	Plan: 1572 Rambler style SFR....1997 UBC	2001
New	1810 sf rambl er w/680 sf garage and 39 sf covered deck/porch		2001
New	27x52, 2001 Golden West		2001
New	Approved Basic #01-101344 BP	Plan: 1460 S SFR w/finished lower floor - 1997 UBC	2001
New	Approved Basic #01-101344 BP	Plan: 1460 S SFR w/finished lower floor - 1997 UBC	2001
New	2 story SFR with attached garage and covered porch		2001
New	Approved Basic #01-101344 BP	Plan: 1460 S SFR w/finished lower floor - 1997 UBC	2001
New	Two Story SFR - 1997 UBC		2001
New	Mid-entry style SFR.....1997 UBC		2001
New	Approved Basic #01-104718 BP	Plan: 1760 S Two Story SFR - 1997 UBC	2001
New	1519sf split level SFR -- 1997 UBC		2001
New	Approved Basic #01-101344 BP	Plan: 1460 S SFR w/finished lower floor - 1997 UBC	2001
New	Mid-entry style SFR.....1997 UBC		2001
New	Approved Basic #01-104718 BP	Plan: 1760 S/H Split Level SFR - 1997 UBC	2001
New	Approved Basic #99-103127BP	Plan: 1558 B Two Story SFR - 1997 UBC	2001
New	Approved Basic #99-103127 BP	Plan: 1558 B Two Story SFR - 1997 UBC	2001
New	Approved Basic #99-109767 BP	Plan: 1256 (front-load) Split Level SFR	2001
New	Approved Basic #99-103127 BP	Plan: 1558 B Two Story SFR - 1997 UBC	2001
New	Approved Basic #99-109767 BP	Plan: 1256 (front-load) Split Level SFR	2001
New	Approved Basic #99-103127BP	Plan: 1558 B Two Story SFR - 1997 UBC	2001

Accessory Dwelling Units

Index # - File Name: 1.0022 - Single Family Dwellings Data\_Snohomish County.pdf

New	Approved Basic #99-103130BP	Plan: 1491	Two Story SFR - 1997 U	2001
New	Approved Basic #99-103130BP	Plan: 1491	Two Story SFR - 1997 U	2001
New	Approved Basic #99-103127 BP	Plan: 1558 B	Two Story SFR - 1997 UBC	2001
New	1988 Barrington 67x27			2001
New	2000 Fleetwood 67x24			2001
New	Approved Basic #01-101344 BP	Plan: 1460 S	SFR w/finished lower floor - 1997 UBC	2001
New	SFR with Attached Garage and 1080 Unfinished Basement			2001
New	27x58 (2001) Marlette			2001
New	Approved Basic #01-108244 BP	Plan No. 2021	2-story style SFR.....1997 UBC	2001
New	1865 sf 2-stroy w/458 sf garage and 24 sf covered deck/porch			2001
New	Approved Basic #01-108242 BP	Plan No. 1896	2-story style SFR....1997 UBC	2001
New	Approved Basic #01-108239 BP	Plan No. 1792	2-story style SFR.....1997 UBC	2001
New	2 story sfr w/attached 3 car garage	Plan #1896		2001
New	1644 s.f. w/479 s.f. finished basement & 2 car garage			2001
New	Two story sfr w/ attached 2 car garage	Plan #2021		2001
New	Approved Basic #01-108244 BP	Plan No. 2021	2-story style SFR.....1997 UBC	2001
New	Approved Basic #01-110647 BP	Plan No. 1865	Two-story style SFR.....1997 UBC	2001
New	Approved Basic #01-108244 BP	Plan No. 2021	2-story style SFR.....1997 UBC	2001
New	Approved Basic #01-110647 BP	Plan No. 1865	Two-story style SFR.....1997 UBC	2001
New	Approved Basic #01-110647 BP	Plan No. 1865	Two-story style SFR.....1997 UBC	2001
New	Approved Basic #01-108244 BP	Plan No. 2021	2-story style SFR.....1997 UBC	2001
New	Two Story w/ 2 Car - 1997 UBC			2001
New	Two-story SFR w/attached garage			2001
New	Two-story SFR w/attached garage			2001
New	Approved Basic #01-107371 BP	Plan: 121-2-3	Rambler style SFR.....1997 UBC	2001
New	Approved Basic #01-107371 BP	Plan: 121-2-3	Rambler style SFR.....1997 UBC	2001
New	14x72, 1979 Sandpointe			2001
New	2 story sfr w/3 car garage			2001
New	Approved Basic #01-106899BP		Rambler style SFR - 1997 UBC	2001
New	2 story SFR with semi fin. daylight basement and attached garage			2001
New	2538sf two-story SFR with attached garage - 1997 UBC			2001
New	2 story w/3 car garage			2001
New	2 Story SFR w/ 3 Car	Plan: M2400A3F-6		2001
New	2 Story SFR w/ 3 Car	Plan M3510A3S-1		2001
New	Approved Basic #01-112017 BP	Plan: 2303 - 35# SL	Two Story SFR ....1997 UBC	2001
New	Approved Basic #01-111261 BP	Plan: 5018 C (bath)-revised	Two Story SFR - 1997	2001
New	Two Story SFR - 1997 UBC	Plan: 5412 A		2001
New	Approved Basic #99-101211BP	Plan: 5023/5123 w/bonus rm	Two Story SFR - 1997 UBC	2001
New	Approved Basic #99-114152 BP	Plan: 5522 w/bonus	Two Story SFR - 1997 UBC	2001
New	Approved Basic #01-111268 BP	Plan: 5118 A (bath) - revised	Two Story SFR - 1997	2001
New	Approved Basic #99-103342BP	Plan: 5222 SEE 01-112424.	Two Story SFR - 1997 UBC	2001
New	Two Story SFR - 1997 UBC	Plan: 5511 B		2001
New	Two Story SFR - 1997 UBC	Plan: 5412 B		2001
New	Two Story SFR - 1997 UBC	Plan: 5210 A		2001
New	Approved Basic #99-101211BP	Plan: 5023/5123 w/bonus rm	Two Story SFR - 1997 UBC	2001
New	Approved Basic #01-111268 BP	Plan: 5118 A (bath) - revised	Two Story SFR - 1997	2001
New	Approved Basic #99-103342BP	Plan: 5222	Two Story SFR - 1997 UBC	2001

Accessory Dwelling Units

Index # - File Name: 1.0022 - Single Family Dwellings Data\_Snohomish County.pdf

New	Approved Basic #01-111265 BP	Plan: 5118 A - revised	Two Story SFR - 1997 UBC	2001
New	Approved Basic #99-103342BP	Plan: 5222	Two Story SFR - 1997 UBC	2001
New	Approved Basic #00-100774 BP	Two Story SFR - 1997 UBC	Plan: 315 A/B	2001
New	Two-story SFR w/attached garage			2001
New	Approved Basic #01-107318 BP	Plan: 2492 R/A/3	Rambler Style SFR - 1997 UBC	2001
New	Approved Basic #00-109412 BP	Plan 2400 A/3	Two Story SFR - 1997 UBC	2001
New	24x60, 1978 Barrington			2001
New	28 x 48 1994 Guerdon			2001
New	Two-story SFR w/attached garage			2001
New	3438 sf 2-story w/675 sf garage and 60 sf covered deck/porch			2001
New	3064 sf 2-story w/816 sf garage and 43 sf covered entry			2001
New	Two Story SFR - 1997 UBC			2001
New	Two Story SFR - 1997 UBC	Plan: 5554		2001
New	Approved Basic #01-111640 BP	Plan: 5552	Two Story SFR - 1997 UBC	2001
New	Approved Basic #01-108126 BP	Plan: 5550 A	Two Story SFR - 1997 UBC	2001
New	Approved Basic #01-111230 BP	Plan: 5250	Two Story SFR - 1997 UBC	2001
New	Two Story SFR - 1997 UBC	Plan: 5552		2001
New	Approved Basic #01-111230 BP	Plan: 5250	Two Story SFR - 1997 UBC	2001
New	2-story style SFR.....1997 UBC			2001
New	Approved Basic 01-105379 BP	Plan #1592 A (Gable)	Rambler w/2 car garage.....199	2001
New	Approved Basic No. 01-105380 BP	Plan #1460 A (Hip)	Rambler w/2 car garage...	2001
New	Approved Basic #01-106269 BP	Plan #1592 B (Hip)	Rambler Style SFR - 1997 UB	2001
New	Approved Basic #01-106266 BP	Plan #1460 B (Gable)	Rambler w/2 car garage....	2001
New	Approved Basic #01-106269 BP	Plan #1592 B	Rambler Style SFR - 1997 UBC	2001
New	Rambler Style SFR - 1997 UBC	Plan: 1592		2001
New	Approved Basic #01-106266 BP	Plan #1460 B	Rambler w/2 car garage.....199	2001
New	Rambler Style SFR - 1997 UBC	Plan: 1460		2001
New	Approved Basic #01-107405 BP	Plan #1446	Rambler Style SFR - 1997 UBC	2001
New	Approved Basic #01-107401 BP	Plan: 1520	Rambler Style SFR - 1997 UBC	2001
New	1446 SF SFR w/3 car garage.....1197 UBC			2001
New	Approved Basic #99-109807 BP	Plan: 2768	Two Story SFR - 1997 UBC	Of 2001
New	Approved Basic #99-109807 BP	Plan: 2768	Two Story SFR - 1997 UBC	Of 2001
New	Approved Basic #01-108192BP	Plan: #2397	Two-story SFR - 1997 UBC	2001
New	Two Story SFR - 1997 UBC	Plan: 1991 F-3,F-1		2001
New	1569 sf rambler w/792 sf garage			2001
New	Approved Basic #01-107405 BP	Plan: 1446	Rambler Style SFR - 1997 UBC	2001
New	Approved Basic #01-107405 BP	Plan: 1446	Rambler Style SFR - 1997 UBC	2001
New	Approved Basic #01-107405 BP	Plan: 1446	Rambler Style SFR - 1997 UBC	2001
New	Approved Basic #01-107401BP	Plan: 1520	Rambler Style SFR - 1997 UBC	2001
New	Approved Basic #01-107401BP	Plan: 1520	Rambler Style SFR - 1997 UBC	2001
New	Approved Basic #01-107401BP	Plan: 1520	Rambler Style SFR - 1997 UBC	2001
New	Approved Basic #01-105949 BP	Plan: 1998 A/2-3	Two Story SFR - 1997 UBC	2001
New	Approved Basic #01-100282 BP	Plan 1784 B/2	Two Story SFR.....1997 UBC	2001
New	Tri-Level SFR - 1997 UBC	Plan: 1885 T/A		2001
New	Approved Basic #01-107405 BP	Plan: 1446	Rambler Style SFR - 1997 UBC	2001
New	Approved Basic #01-107405 BP	Plan: 1446	Rambler Style SFR - 1997 UBC	2001
New	Approved Basic #01-101569 BP	Plan: 1885 T/A	Tri-Level SFR - 1997 UBC	2001

Accessory Dwelling Units

Index # - File Name: 1.0022 - Single Family Dwellings Data\_Snohomish County.pdf

New	1 story SFR w/ 3 car garage		2001
New	Approved Basic #00-109999 BP	Plan: 2063 A-1 Rambler Style SFR - 1997 UBC	2001
New	Approved Basic #01-100282 BP	Plan 1784 B/2 Two Story SFR.....1997	2001
New	2386 sf 2-story w/695 sf garage and 91 sf covered entry - 1997UBC		2001
New	Approved Basic #01-108101 BP	Plan: 2386 Two Story SFR - 1997 UBC	2001
New	Approved Basic #01-107405 BP	Plan: 1446 Rambler Style SFR - 1997 UBC	2001
New	Approved Basic #99-109806 BP	Plan: 2628 Two Story SFR - 1997 UBC	2001
New	Approved Basic #01-107405 BP	Plan: 1446 Rambler Style SFR - 1997 UBC	2001
New	Approved Basic #01-107401BP	Plan: 1520 Rambler Style SFR - 1997 UBC	2001
New	Approved Basic #01-107405 BP	Plan: 1446 Rambler Style SFR - 1997 UBC	2001
New	Approved Basic #01-107405 BP	Plan: 1446 Rambler Style SFR - 1997 UBC	2001
New	Approved Basic #01-107401BP	Plan: 1520 Rambler Style SFR - 1997 UBC	2001
New	Approved Basic #01-107401BP	Plan: 1520 Rambler Style SFR - 1997 UBC	2001
New	Two-story SFR w/attached garage		2001
New	Approved Basic #99-101606BP	Plan #2207 Two Story SFR - 1997 UB	2001
New	Approved Basic #01-111312 BP	Plan: 2431 Two Story SFR - 1997 UBC	2001
New	Two Story SFR - 1997 UBC		2001
New	One-story SFR w/attached garage		2001
New	2001 Golden West 52x27		2001
New	Approved Basic #98-110231BP	Plan: Rutledge 1365 One-story SFR w/finis	2001
New	Approved Basic #01-106966 BP	Plan #1741 Two Story SFR - 1997 UBC	2001
New	Approved Basic #01-105949 BP	Plan: 1998 A/2-3 Two Story SFR - 1997 UBC	2001
New	Approved Basic #01-106691 BP	Plan: M 1992 F3 F1 Two Story SFR - 1997 UBC	2001
New	Approved Basic #01-105949 BP	Plan: 1998 A/2-3 Two Story SFR - 1997 UBC	2001
New	Approved Basic #01-106691 BP	Plan: M 1992 F3 F1 Two Story SFR - 1997 UBC	2001
New	1999 813600 Goldenwest 27x66		2001
New	Two-story SFR with attached garage - 1997UBC		2001
New	Approved Basic 99-101299BP	Plan: #10 Mid-Entry With 2 Car - 1997 UI	2001
New	Approved Basic #01-111927 BP	Plan 1910/Pin SFR w/finished lower floor - 1	2001
New	Approved Basic #01-111927 BP	Plan 1910/Pin SFR w/finished lower floor -	2001
New	2001 Golden West Homes 66x40		2001
New	Two Story SFR with Attached Garageand 106 SF Finished Basement		2001
New	Approved Basic #01-100477 BP	Plan: 1465 A Two Story SFR - 1997 UBC	2001
New	Two Story SFR - 1997 UBC	Plan: Adams/Gable	2001
New	Approved Basic #01-105949 BP	Plan: 1998 A/2-3 Two Story SFR - 1997 UBC	2001
New	Approved Basic #01-100282 BP	Plan 1784 B/2 Two Story SFR.....1997	2001
New	Approved Basic #01-105949 BP	Plan: 1998 A/2-3 Two Story SFR - 1997 UBC	2001
New	Approved Basic #01-101569 BP	Plan: 1885 T/A Tri-Level SFR - 1997 UBC	2001
New	Approved Basic #01-100282 BP	Plan 1784 B/2 Two Story SFR.....1997	2001
New	Two Story SFR - 1997 UBC	Plan: Whitney/Hip	2001
New	Two Story SFR - 1997 UBC	Plan: Trinity/Gable	2001
New	40 X 70 2001 Pacifica		2001
New	Approved Basic #00-104229 BP	Plan: 1533 revised Two Story SFR - 1997 UE	2001
New	Approved Basic #00-104229 BP	Plan: 1533 revised Two Story SFR - 1997 UE	2001
New	Approved Basic #00-104229 BP	Plan: 1533 revised Two Story SFR - 1997 UE	2001
New	Approved Basic #00-103206 BP	Plan: 1528 Rambler Style SFR - 1997 UBC	2001
New	Approved Basic #00-104229 BP	Plan: 1533 revised Two Story SFR - 1997 UE	2001

Accessory Dwelling Units

Index # - File Name: 1.0022 - Single Family Dwellings Data\_Snohomish County.pdf

New	Approved Basic #01-108169 BP	Plan: 1533 end	Two Story SFR - 1997	2001
New	Approved Basic #00-104229 BP	Plan: 1533 revised	Two Story SFR - 1997 UE	2001
New	Approved Basic #00-104229 BP	Plan: 1533 revised	Two Story SFR - 1997 UE	2001
New	Approved Basic #00-103206 BP	Plan: 1528	Rambler Style SFR - 1997 UBC	2001
New	Two Story SFR - 1997 UBC	Plan: Olympic/Gable		2001
New	Approved Basic #01-101569 BP	Plan: 1885 T/A	Tri-Level SFR - 1997 UBC	2001
New	Approved Basic #01-104460 BP	Plan 1784 A/2	Two Story SFR.....1997 UBC	2001
New	Two Story SFR with Attached Garage			2001
New	Two Story SFR with Attached Garage	Pan1850		2001
New	2524 sf 2-story w/720 sf garage			2001
New	Two Story SFR - 1997 UBC			2001
New	Approved Basic #01-105949 BP	Plan: 1998 A/2-3	Two Story SFR - 1997 UBC	2001
New	Two Story SFR - 1997 UBC	Builder s Plan: 1913		2001
New	Approved Basic #00-110368 BP	Plan: 2056	Two Story SFR - 1997 UBC	2001
New	Approved Basic #00-110368 BP	Plan: 2056	Two Story SFR - 1997 UBC	2001
New	Approved Basic #00-110368 BP	Plan: 2056	Two Story SFR - 1997 UBC	2001
New	Approved Basic #00-110368 BP	Plan: 2056	Two Story SFR - 1997 UBC	2001
New	2-story SFR w/loft.....1997 UBC			2001
New	2-story style SFR....1997 UBC			2001
New	Approved Basic #01-111382 BP	Plan #1744	Two Story SFR - 1997 UBC	2001
New	Approved Basic #01-111382 BP	Plan #1744	Two Story SFR - 1997 UBC	2001
New	Approved Basic #01-111345 BP	Plan 1965-K	Two-story style SFR.....1997 UBC	2001
New	2 story sfr w/garage	Builders Plan #1920G		2001
New	Two-story style SFR.....1997 UBC	Plan No. 2164-H		2001
New	Approved Basic #01-112732 BP	Plan: 1920 Gable	Two Story SFR - 1997 UBC	2001
New	Two-story style SFR.....1997 UBC	Plan No. 2170-H		2001
New	Two-story style SFR.....1997 UBC	Plan No. 2164-G		2001
New	Mid-Entry style SFR.....1997 UBC	Plan No. 2321-G		2001
New	Approved Basic #01-112967 BP	Plan No. 1920	Two Story style SFR - 1997 UBC	2001
New	Approved Basic #01-112965 BP	Plan No. 2170	Two-story style SFR - 1997 UB	2001
New	Approved Basic #01-112969 BP	Plan No. 2321	Mid-entry SFR - 1997 UBC	2001
New	Approved Basic #01-112730 BP	Plan: 1920 Hip	Two Story SFR - 1997 UBC	2001
New	Two-story style SFR.....1997 UBC	Plan No. 2288-G		2001
New	2 story sfr w/garage	Builders Plan #1920H		2001
New	Approved Basic #01-112733 BP	Plan No. 2321-Gable	Split level SFR w/finish	2001
New	Two-story style SFR.....1997 UBC	Plan No. 2170-G		2001
New	Approved Basic #00-103622 BP	Plan: 1399 (slab)	Rambler Style SFR - 1997 UBC	2001
New	Approved Basic #00-103622 BP	Plan: 1399 (slab)	Rambler Style SFR - 1997 UBC	2001
New	Approved Basic #00-103622 BP	Plan: 1399 (slab)	Rambler Style SFR - 1997 UBC	2001
New	Rambler Style SFR - 1997 UBC	Plan: 1253		2001
New	Approved Basic #00-103621 BP	Plan: 1199 (slab)	Rambler Style SFR - 1997 UB	2001
New	Two-story style SFR.....1997 UBC	Plan No. 2288-H		2001
New	Approved Basic #00-103622 BP	Plan: 1399 (slab)	Rambler Style SFR - 1997 UBC	2001
New	Approved Basic #00-103622 BP	Plan: 1399 (slab)	Rambler Style SFR - 1997 UBC	2001
New	1024 s.f. rambler w/2 car garage			2001
New	Approved Basic #01-112384 BP	Plan: 1253 slab (Elev B)	Rambler Style SFR - 199	2001
New	Approved Basic #00-103622 BP	Plan: 1399 (slab)	Rambler Style SFR - 1997 UBC	2001

Accessory Dwelling Units

Index # - File Name: 1.0022 - Single Family Dwellings Data\_Snohomish County.pdf

New	Approved Basic #00-103622 BP	Plan: 1399 (slab)	Rambler Style SFR - 1997 UBC	2001
New	Rambler Style SFR - 1997 UBC			2001
New	Approved Basic #00-103622 BP	Plan: 1399 (slab)	Rambler Style SFR - 1997 UBC	2001
New	Rambler Style SFR - 1997 UBC			2001
New	Approved Basic #99-101472BP	Plan: 1200	Rambler Style SFR - 1997 UBC	2001
New	Approved Basic #00-103622 BP	Plan: 1399 (slab)	Rambler Style SFR - 1997 UBC	2001
New	Approved Basic #00-103622 BP	Plan: 1399 (slab)	Rambler Style SFR - 1997 UBC	2001
New	Approved Basic #00-103621 BP	Plan: 1199 (slab)	Rambler Style SFR - 1997 UB	2001
New	Approved Basic #00-103622 BP	Plan: 1399 (slab)	Rambler Style SFR - 1997 UBC	2001
New	Approved Basic #00-103622 BP	Plan: 1399 (slab)	Rambler Style SFR - 1997 UBC	2001
New	27 x 60 Palm Harbor			2001
New	Rambler Style SFR - 1997 UBC			2001
New	Two Story SFR			2001
New	1910 sf rambler w/440 sf garage , 207 sf covered deck/porch and 350 sf open deck			2001
New	27x52 2002 Golden West			2001
New	Two-story SFR - 1997 UBC			2001
New	Two-story style SFR - 1997 UBC	Plan 2390		2001
New	Approved Basic #98-108806BP	Plan 1936 Split	1174 sf SFR w/semi-fini	2001
New	Approved Basic #98-108806BP	Plan 1936 Split	1174 sf SFR w/semi-fini	2001
New	Approved Basic #01-113099 BP	Plan 2193	Split level SFR - 1997 UBC	2001
New	Approved Basic #98-108803BP	Plan 1750 Cal	1174 sf SFR w/semi-finished	2001
New	Approved Basic #98-108806BP	Plan 1936 Split	1174 sf SFR w/semi-fini	2001
New	Split level SFR - 1997 UBC	Bldrs Plan 2193		2001
New	Approved Basic #98-108803BP	Plan 1750 Cal	1174 sf SFR w/semi-finished	2001
New	Approved Basic #98-108803BP	Plan 1750 Cal	1174 sf SFR w/semi-finished	2001
New	Approved Basic #01-112836 BP	Plan: 1221	Two Story SFR - 1997 UBC	2001
New	Two-story SFR - 1997 UBC	Builders Plan 1130		2001
New	Two-story SFR - 1997 UBC	Bldrs Plan # 1221	Carlow Court	2001
New	Approved Basic #98-108806BP	Plan 1936 Split	1174 sf SFR w/semi-fini	2001
New	Approved Basic #98-108806BP	Plan 1936 Split	1174 sf SFR w/semi-fini	2001
New	Approved Basic #01-112836 BP	Plan: 1221	Two Story SFR - 1997 UBC	2001
New	Approved Basic #01-112836 BP	Plan: 1221	Two Story SFR - 1997 UBC	2001
New	Approved Basic #98-108803BP	Plan 1750 Cal	1174 sf SFR w/semi-finished	2001
New	Approved Basic #98-108806BP	Plan 1936 Split	1174 sf SFR w/semi-fini	2001
New	Approved Basic #98-108803BP	Plan 1750 Cal	1174 sf SFR w/semi-finished	2001
New	Approved Basic #98-108803BP	Plan 1750 Cal	1174 sf SFR w/semi-finished	2001
New	Approved Basic #00-100867 BP	Plan: 2220	Mid Entry SFR - 1997 UBC	2001
New	Approved Basic #99-113717 BP	Plan: #2002	Two Story SFR - 1997 UBC	( 2001
New	Approved Basic #01-112898 BP	Bldrs Plan 9905	Mid-Entry SFR - 1997 UBC	2001
New	Approved Basic #00-106859 BP	Plan: 1927	Two Story SFR - 1997 UBC	2001
New	Approved Basic #99-113717 BP	Plan: #2002	Two Story SFR - 1997 UBC	( 2001
New	Approved Basic #01-112605 BP	Plan: 0122	Two Story SFR - 1997 UBC	2001
New	Approved Basic #99-113717 BP	Plan: #2002	Two Story SFR - 1997 UBC	( 2001
New	Approved Basic #01-112605 BP	Plan: 0122	Two Story SFR - 1997 UBC	2001
New	Approved Basic #99-113717 BP	Plan: #2002	Two Story SFR - 1997 UBC	( 2001
New	Approved Basic #01-103744 BP	Plan: Willow	Two Style SFR - 1997 UBC	2001
New	Approved Basic #99-113717 BP	Plan: #2002	Two Story SFR - 1997 UBC	( 2001



Accessory Dwelling Units

Index # - File Name: 1.0022 - Single Family Dwellings Data\_Snohomish County.pdf

New	Two-story SFR w/finished basement	Plan 0124	2001
New	2 story w/garage	Builders Plan #0123	2001
New	2 story w/garage	Builders Plan #0122	2001
New	Approved Basic #01-103739 BP	Plan: Colby Two Story SFR - 1997 UBC	2001
New	2 story sfr w/3 car garage		2001
New	2224sf One-story SFR with attached garage - 1997 UBC		2001
New	Approved Basic #99-111975 BP	Plan: 1533 Two Story SFR - 1997 UBC	2001
New	Approved Basic #00-102507 BP	Plan: 1290 Two Story SFR - 1997 UBC	2001
New	Approved Basic #00-100981 BP	Plan: 1632 Two Story SFR - 1997 UBC	2001
New	Approved Basic #99-111975 BP	Plan: 1533 Two Story SFR - 1997 UBC	2001
New	Approved Basic #00-100981 BP	Plan: 1632 Two Story SFR - 1997 UBC	2001
New	Approved Basic #00-102507 BP	Plan: 1290 Two Story SFR - 1997 UBC	2001
New	Approved Basic #99-111975 BP	Plan: 1533 Two Story SFR - 1997 UBC	2001
New	Approved Basic #00-102507 BP	Plan: 1290 Two Story SFR - 1997 UBC	2001
New	Approved Basic #99-111975 BP	Plan: 1533 Two Story SFR - 1997 UBC	2001
New	Approved Basic #00-100981 BP	Plan: 1632 Two Story SFR - 1997 UBC	2001
New	Approved Basic #01-101344 BP	Plan: 1460 S SFR w/finished lower floor - 1997 UBC	2001
New	1756 sf tri level w/480 sf garage, 24 sf covered deck/porch and 80 sf open deck		2001
New	Mid-entry SFR.....1997 UBC		2001
New	Approved Basic #01-101344 BP	Plan: 1460 S SFR w/finished lower floor - 1997 UBC	2001
New	Split Level SFR with attached garage		2001
New	Split Level SFR with attached garage		2001
New	Approved Basic #00-109943 BP	Plan: Duplex Two Story Duplex	2001
New	Approved Basic #00-109943 BP	Plan: Duplex Two Story Duplex	2001
New	Approved Basic #01-104718 BP	Plan: 1760 S/H Split Story SFR - 1997 UBC	2001
New	Approved Basic #00-109207 BP	Plan #2294 A2 F-2 Two Story SFR - 1997 UBC	2001
New	Approved Basic #00-109209 BP	Plan 2146 Two Story SFR - 1997 UBC	2001
New	Approved Basic #00-109207 BP	Plan #2294 A2 F-2 Two Story SFR - 1997 UBC	2001
New	Approved Basic #01-100272 BP	Plan: 1665 Two Story SFR - 1997 UBC	2001
New	Approved Basic #99-114285 BP	Plan # Aspen 2 Two Story SFR - 1997 UBC	2001
New	Approved Basic #00-109209 BP	Plan 2146 Two Story SFR - 1997 UBC	2001
New	Approved Basic #00-109207 BP	Plan #2294 A2 F-2 Two Story SFR - 1997 UBC	2001
New	Approved Basic #99-114285 BP	Plan # Aspen 2 Two Story SFR - 1997 UBC	2001
New	Approved Basic #00-103631 BP	Plan: 1745 Two Story SFR - 1997 UBC	2001
New	Approved Basic #01-100271 BP	Plan: 1987 Two Story SFR - 1997 UBC	2001
New	Approved Basic #00-109209 BP	Plan 2146 Two Story SFR - 1997 UBC	2001
New	Approved Basic #00-103631 BP	Plan: 1745 Two Story SFR - 1997 UBC	2001
New	2 story sfr w/2 car garage		2001
New	Approved Basic #00-109209 BP	Plan 2146 Two Story SFR - 1997 UBC	2001
New	Approved Basic #99-114285 BP	Plan # Aspen 2 Two Story SFR - 1997 UBC	2001
New	Two-story SFR w/attached garage		2001
New	Approved Basic #00-102507 BP	Plan: 1290 Two Story SFR - 1997 UBC	2001
New	Approved Basic #99-111975 BP	Plan: 1533 Two Story SFR - 1997 UBC	2001
New	Approved Basic #00-102507 BP	Plan: 1290 Two Story SFR - 1997 UBC	2001
New	Approved Basic #99-111975 BP	Plan: 1533 Two Story SFR - 1997 UBC	2001
New	Approved Basic #00-102507 BP	Plan: 1290 Two Story SFR - 1997 UBC	2001
New	Approved Basic #99-111975 BP	Plan: 1533 Two Story SFR - 1997 UBC	2001

Accessory Dwelling Units

Index # - File Name: 1.0022 - Single Family Dwellings Data\_Snohomish County.pdf

New	Approved Basic #00-102507 BP	Plan: 1290 Two Story SFR - 1997 UBC	2001
New	Approved Basic #99-111975 BP	Plan: 1533 Two Story SFR - 1997 UBC	2001
New	One-story SFR w/attached garage		2001
New	27.4 x 60 Concept 28262		2001
New	2 story sfr w/2 car garage		2001
New	2-story style Duplex...1997 UBC		2001
New	1400sf two-story SFR - 1997 UBC		2001
New	Approved Basic #00-102012 BP	Plan: 2350 Two Story SFR - 1997 UBC	2001
New	2510 sf 2-story w/630 sf garage, and 232 sf covered deck/porch		2001
New	Approved Basic #00-102012 BP	Plan: 2350 Two Story SFR - 1997 UBC	2001
New	1 story SFR w/ 3 car garage		2001
New	Approved Basic #00-103152 BP	Plan: 2464 Two Story SFR - 1997 UBC	2001
New	1996 sf 2-story w/610 sf finished basement w/746 sf garage and 240 sf open deck		2001
New	Approved Basic #00-102579-BP	Plan: 2220 S/2 Mid-Entry Style SFR w/finished	2001
New	Approved Basic #98-107153BP	Plan #1837 Two Story SFR - 1997	2001
New	Approved Basic #01-103753 BP	Plan: Avalon Two Story SFR - 1997 UBC	2001
New	Approved Basic #99-103777BP	Plan: 2415 A/3 Two Story SFR - 1997 UBC	2001
New	Approved Basic #00-106010 BP	Plan: 2342 Two Story SFR - 1997 UBC	2001
New	Approved Basic No. 01-103877 BP	Bldrs Plan No. 2297 Two-story SFR.....1997	2001
New	2-story SFR.....1997 UBC		2001
New	Approved Basic #00-106097 BP	Plan: 2415 Two Story SFR - 1997 UBC	2001
New	Approved Basic #99-116088 BP	Plan: 2461 Two Story SFR - 1997 UBC	2001
New	Approved Basic #00-103049 BP	Plan: 2076 Two Story SFR - 1997 UBC	2001
New	Approved Basic #01-103753 BP	Plan: Avalon Two Story SFR - 1997 UBC	2001
New	Approved Basic #99-115755 BP	Two Story SFR - 1997 UBC	Plan: 227 2001
New	Approved Basic #00-104974 BP	Plan: 2461 revised Two Story SFR - 1997 UBC	2001
New	Approved Basic #00-110940 BP	Plan: 2223 Two Story SFR - 1997 UBC	2001
New	Approved Basic #00-107245 BP	Plan: 2052 - front load (revised) Two Story SFR -	2001
New	Approved Basic #00-106097 BP	Plan: 2415 Two Story SFR - 1997 UBC	2001
New	Approved Basic #99-116088 BP	Plan: 2461 Two Story SFR - 1997 UBC	2001
New	Approved Basic #00-104350 BP	Plan: 2535 A/3 Two Story SFR - 1997 UBC	2001
New	Approved Basic #99-115755 BP	Two Story SFR - 1997 UBC	Plan: 227 2001
New	Approved Basic #99-103777BP	Plan: 2415 A/3 Two Story SFR - 1997 UBC	2001
New	Approved Basic #99-115755 BP	Two Story SFR - 1997 UBC	Plan: 227 2001
New	Approved Basic #00-103049 BP	Plan: 2076 Two Story SFR - 1997 UBC	2001
New	Approved Basic #00-107245 BP	Plan: 2052 - front load (revised) Two Story SFR -	2001
New	Approved Basic #00-110940 BP	Plan: 2223 Two Story SFR - 1997 UBC	2001
New	Approved Basic #00-106010 BP	Plan: 2342 Two Story SFR - 1997 UBC	2001
New	Approved Basic #00-106097 BP	Plan: 2415 Two Story SFR - 1997 UBC	2001
New	Approved Basic #99-116026BP	Plan: Kensington Two Story SFR - 1997 UBC	2001
New	2-Story SFR w/attached garage.	Bldrs s Plan Berkeley	2001
New	Approved Basic #99-115755 BP	Two Story SFR - 1997 UBC	Plan: 227 2001
New	Rambler style SFR with attached garage		2001
New	Two Story SFR - 1997 UBC		2001
New	Two story SFR w/unfinished basement - 1997 UBC		2001
New	1570 s.f. rambler w/2 car garage/shop		2001
New	2755 SF SFR w/3 car garage		2001

Accessory Dwelling Units

Index # - File Name: 1.0022 - Single Family Dwellings Data\_Snohomish County.pdf

New	Approved Basic 99-104619 BP	Builders Plan 1024A	One-story SFR w	2001
New	SFR with Finished Basement and Attached Garage			2001
New	2 story sfr w/2 car garage			2001
New	Approved Basic #00-109207 BP	Plan: 2294 A2 F-2	Two Story SFR - 1997 UBC	2001
New	Approved Basic #00-109207 BP	Plan #2294 A2 F-2	Two Story SFR - 1997 UBC	2001
New	Approved Basic #00-109209 BP	Plan 2146	Two Story SFR - 1997 UBC	2001
New	Approved Basic #00-109207 BP	Plan #2294 A2 F-2	Two Story SFR - 1997 UBC	2001
New	Approved Basic #00-108636 BP	Plan: M 1983 A/B 2F-1	Two Story SFR - 1997 UBC	2001
New	Approved Basic #00-103631 BP	Plan: 1745	Two Story SFR - 1997 UBC	2001
New	Approved Basic #00-109209 BP	Plan 2146	Two Story SFR - 1997 UBC	2001
New	Approved Basic #99-114285 BP	Plan # Aspen 2	Two Story SFR - 1997 UBC	2001
New	Approved Basic #99-114285 BP	Plan # Aspen 2	Two Story SFR - 1997 UBC	2001
New	Approved Basic #00-109209 BP	Plan 2146	Two Story SFR - 1997 UBC	2001
New	Approved Basic #00-109207 BP	Plan #2294 A2 F-2	Two Story SFR - 1997 UBC	2001
New	Approved Basic #99-114285 BP	Plan # Aspen 2	Two Story SFR - 1997 UBC	2001
New	Approved Basic #00-109209 BP	Plan 2146	Two Story SFR - 1997 UBC	2001
New	Approved Basic #01-100271 BP	Plan: 1987	Two Story SFR - 1997 UBC	2001
New	Approved Basic #01-100271 BP	Plan: 1987	Two Story SFR - 1997 UBC	2001
New	Approved Basic #01-100271 BP	Plan: 1987	Two Story SFR - 1997 UBC	2001
New	Approved Basic #01-100271 BP	Plan: 1987	Two Story SFR - 1997 UBC	2001
New	Approved Basic #00-109207 BP	Plan #2294 A2 F-2	Two Story SFR - 1997 UBC	2001
New	Approved Basic #01-100272 BP	Plan: 1665	Two Story SFR - 1997 UBC	2001
New	Approved Basic #99-101442 BP	Plan: M 1974 A2F-0	Two Story SFR - 1997 UBC	2001
New	Two Story SFR - 1997 UBC			2001
New	Approved Basic #99-114285 BP	Plan # Aspen 2	Two Story SFR - 1997 UBC	2001
New	Approved Basic #00-107481 BP	Plan: D	Two Story SFR - 1997 UBC	2001
New	Approved Basic #99-114285 BP	Plan # Aspen 2	Two Story SFR - 1997 UBC	2001
New	Approved Basic #99-116024BP	Plan: Avalon	Two Story SFR - 1997 UBC	2001
New	Approved Basic #00-106102 BP	Plan: Waterbrooke	Two Story SFR - 1997 UE	2001
New	Approved Basic #98-108359BP	(3 Bedroom)	Two Story SFR - 1997 L	2001
New	Approved Basic #99-115756 BP	Plan: 1884	Two Story SFR - 1997 UBC	2001
New	Approved Basic #98-107153BP	Plan #1837	Two Story SFR - 1997 UBC	2001
New	Approved Basic #00-110940 BP	Plan: 2223	Two Story SFR - 1997 UBC	2001
New	Approved Basic #00-103049 BP	Plan: 2076	Two Story SFR - 1997 UBC	2001
New	Two Story SFR - 1997 UBC	0 Lot Line Structure		2001
New	Approved Basic #01-106905 BP	0 Lot Line Structure	Two Story SFR - 1997 UBC	2001
New	Approved Basic #00-110606 BP	Plan: 1790	Two Story SFR - 1997 UBC	2001
New	Approved Basic #00-110604 BP	Plan: 1832	Two Story SFR - 1997 UBC	2001
New	Approved Basic #00-110606 BP	Plan: 1790	Two Story SFR - 1997 UBC	2001
New	Approved Basic #00-110735 BP	Plan: #4007	Two Story SFR - 1997 UBC	2001
New	Approved Basic #00-110735 BP	Plan: #4007	Two Story SFR - 1997 UBC	2001
New	Two Story SFR - 1997 UBC	0 LOT LINE STRUCTURE		2001
New	Two Story SFR with Attached Garage			2001
New	Two-story SFR w/attached garage	Plan 90010		2001
New	2 Story w/ 2 Car			2001
New	2560 s.f. rambler w/garage (630 s.f. & 435 s.f. 2nd floor storage)			2001
New	Approved Basic #01-104101 BP	Plan TJI/2497	Two story SFR w/attached garag	2001

Accessory Dwelling Units

Index # - File Name: 1.0022 - Single Family Dwellings Data\_Snohomish County.pdf

New	Approved Basic #01-104101 BP	Plan TJI/2497	Two story SFR w/attached gara	2001
New	2230 sf rambler w/772 sf garage and 80 sf covered deck/porch			2001
New	Approved Basic #01-110907 BP		Two Story SFR - 1997 UBC	2001
New	Approved Basic #01-108132 BP	Plan No. 2621	Two Story SFR.....1997 UBC	2001
New	2-story style SFR.....1997 UBC			2001
New	Approved Basic #98-150628BP		Plan: 50 er Two Story SFR - 1997 UBC	2001
New	Two Story SFR -1997 UBC	Plan: 2738		2001
New	Two Story SFR - 1997 UBC	Plan: 2497 - 62	wide version	2001
New	2349 SF SFR w/ garage...1997 UBC	Plan #2656	w/out pod	2001
New	Approved Basic #98-150633BP		Plan: 44 er Two Story SFR - 1997	2001
New	Approved Basic #01-101541BP	Plan: 2877	Two Story SFR - 1997 UBC	2001
New	Approved Basic #00-109193 BP		Plan: 1558 Two Story SFR - 1997 UBC	2001
New	Approved Basic #00-109225 BP	Plan #1599 Elev. C	Mid entry SFR - 1997 UBC	2001
New	Approved Basic #00-109084 BP	Plan #1599 Elev. A	Mid entry SFR - 1997 UBC	2001
New	Approved Basic #00-109193 BP		Plan: 1558 Two Story SFR - 1997 UBC	2001
New	Approved Basic #00-109225 BP	Plan #1599 Elev. C	Mid entry SFR - 1997 UBC	2001
New	Approved Basic #00-109193 BP		Plan: 1558 Two Story SFR - 1997 UBC	2001
New	Approved Basic #00-109195 BP		Plan: 1440 Two Story SFR - 1997 UBC	2001
New	Approved Basic #00-109195 BP		Plan: 1440 Two Story SFR - 1997 UBC	2001
New	Approved Basic #00-109223 BP	Plan #1599 Elev. B	Mid entry SFR - 1997 UBC	2001
New	Approved Basic #00-109193 BP		Plan: 1558 Two Story SFR - 1997 UBC	2001
New	Approved Basic #00-109195 BP		Plan: 1440 Two Story SFR - 1997 UBC	2001
New	Approved Basic #00-109084 BP	Plan #1599 Elev. A	Mid entry SFR - 1997 UBC	2001
New	Approved Basic #00-109225 BP	Plan #1599 Elev. C	Mid entry SFR - 1997 UBC	2001
New	Approved Basic #00-109193 BP		Plan: 1558 Two Story SFR - 1997 UBC	2001
New	Approved Basic #00-109225 BP	Plan #1599 Elev. C	Mid entry SFR - 1997 UBC	2001
New	Approved Basic #00-109195 BP		Plan: 1440 Two Story SFR - 1997 UBC	2001
New	Approved Basic #00-109223 BP	Plan #1599 Elev. B	Mid entry SFR - 1997 UBC	2001
New	Approved Basic #00-109193 BP		Plan: 1558 Two Story SFR - 1997 UBC	2001
New	Approved Basic #00-109084 BP	Plan #1599 Elev. A	Mid entry SFR - 1997 UBC	2001
New	Approved Basic #00-109193 BP		Plan: 1558 Two Story SFR - 1997 UBC	2001
New	Approved Basic #00-109193 BP		Plan: 1558 Two Story SFR - 1997 UBC	2001
New	Approved Basic #00-109225 BP	Plan #1599 Elev. C	Mid entry SFR - 1997 UBC	2001
New	Approved Basic #00-109193 BP		Plan: 1558 Two Story SFR - 1997 UBC	2001
New	Two story with 2 car garage			2001
New	3464 sf 2-story w/766 sf garage w/70 sf covered deck/porch			2001
New	Custom Rambler w/bonus bedroom on 2nd floor w/3-car garage....1997 UBC			2001
New	2-story SFR.....1997 UBC	Bldrs Plan No. 2620	2-Story	2001
New	Approved Basic #98-150628BP		Plan: 50 er Two Story SFR - 1997 UBC	2001
New	Approved Basic #98-150628BP		Plan: 50 er Two Story SFR - 1997 UBC	2001
New	Approved Basic #01-104726 BP	Plan # 45 2673	Two-story SFR.....1997 UBC	2001
New	Two Story SFR with Attached Garage			2001
New	Approved Basic #99-110432 BP		Plan: 52 er Two Story SFR - 199	2001
New	Approved Basic #01-107344 BP	Plan: TJI 2783	Two Story SFR - 1997 UBC	2001
New	Approved Basic #01-101499 BP		Plan: 52 er - revised Two Story SFR - 1997 UBC	2001
New	Approved Basic #01-107346 BP	Plan: SSI 2783	Two Story SFR - 1997 UBC	2001
New	Approved Basic #01-101541BP	Plan: 2877	Two Story SFR - 1997 UBC	2001

Accessory Dwelling Units

Index # - File Name: 1.0022 - Single Family Dwellings Data\_Snohomish County.pdf

New	Approved Basic #01-104100 BP	Plan SSI/2497	Two story SFR w/attached gara	2001
New	2-story style SFR.....1997 UBC			2001
New	Approved Basic #01-107346 BP	Plan: SSI 2783	Two Story SFR - 1997 UBC	2001
New	Approved Basic #00-100585 BP	Plan: 662 B	Two Story SFR - 1997 UBC	2001
New	Approved Basic #01-106318 BP	Plan: 1926 D	Two Story SFR - 1997 UBC	2001
New	Two Story SFR - 1997 UBC	Plan: F932 A/B/C		2001
New	Approved Basic #99-114666 BP	Plan: F932	Two Story SFR - 1997 UBC	2001
New	Approved Basic #01-106318 BP	Plan: 1926 D	Two Story SFR - 1997 UBC	2001
New	2876 sf 2-story w/762 sf garage and 40 sf covered deck/porch			2001
New	34 x 50 x 60 SFR with attached garage...1997 UBC			2001
New	40 x 72 SFR with attached garage ...1997 UBC			2001
New	2621 SF SFR w/garage			2001
New	Two Story SFR - 1997 UBC	Plan: 3150		2001
New	1678 sf 2-story w/ 528 sf garage, and 40 sf covered deck/porch			2001
New	28 x 48 2000 Palm Harbor			2001
New	One-story SFR w/attached garage			2001
New	Approved Basic #00-100585 BP	Plan: 662 B	Two Story SFR - 1997 UBC	2001
New	Approved Basic #00-100585 BP	Plan: 662 B	Two Story SFR - 1997 UBC	2001
New	Approved Basic #01-111585 BP	Plan: F 932 C	Two Story SFR - 1997 UBC	2001
New	Two Story SFR - 1997 UBC	Plan: 4090 A/B		2001
New	Approved Basic #01-100990 BP	Plan: 511 B	Two Story SFR - 1997 UBC	2001
New	Two Story SFR - 1997 UBC	Plan: 569		2001
New	Approved Basic #01-100405 BP	Plan: 949 G	Two Story SFR - 1997 UBC	2001
New	Approved Basic #00-101532 BP	Bldrs Plan No. 511 M	Two Story SFR - 1997 UBC	2001
New	Approved Basic #99-116037	Plan: 865 A/B	Two Story SFR - 1997 UBC	2001
New	Approved Basic # 00-101281BP	Plan: 949 A	Two Story SFR - 1997 UBC	2001
New	Two Story SFR - 1997 UBC			2001
New	Approved Basic #01-111585 BP	Plan: F 932 C	Two Story SFR - 1997 UBC	2001
New	Two Story SFR - 1997 UBC	Plan: 1926 D		2001
New	Approved Basic #99-116037	Plan: 865 A/B	Two Story SFR - 1997 UBC	2001
New	Approved Basic # 00-101281BP	Plan: 949 A	Two Story SFR - 1997 UBC	2001
New	Two Story SFR - 1997 UBC			2001
New	Approved Basic #01-100405 BP	Plan: 949 G	Two Story SFR - 1997 UBC	2001
New	Approved Basic #99-114666 BP	Plan: F932	Two Story SFR - 1997 UBC	2001
New	Approved Basic #99-116037 BP	Plan: 865	Two Story SFR - 1997 UBC	2001
New	Approved Basic #01-106318 BP	Plan: 1926 D	Two Story SFR - 1997 UBC	2001
New	Approved Basic #99-103818BP	Plan: 1195 (Floor Framing Change)	Rambler Style SFR -	2001
New	Approved Basic #99-103818BP	Plan: 1195 (Floor Framing Change)	Rambler Style SFR -	2001
New	Approved Basic #99-103818BP	Plan: 1195 (Floor Framing Change)	Rambler Style SFR -	2001
New	Two Story SFR - 1997 UBC	Plan #1360		2001
New	Approved Basic #99-103818BP	Plan: 1195 (Floor Framing Change)	Rambler Style SFR -	2001
New	Approved Basic #99-103817BP	Plan: 1200 (Floor Framing Change)	Rambler Style	2001
New	Approved Basic #99-103817BP	Plan: 1200 (Floor Framing change)	Rambler Styl	2001
New	Approved Basic 99-115184 BP	Plan: 1399	Rambler Style SFR - 1997 UBC	2001
New	Approved Basic #99-103818BP	Plan: 1195 (Floor Framing Change)	Rambler Style SFR -	2001
New	2330 sf 2-story w/ 1314 sf garage and 147 sf covered porch			2001
New	Approved Basic #99-115181 BP	Plan: 1199	Rambler Style SFR - 1997 UBC	2001

Accessory Dwelling Units

Index # - File Name: 1.0022 - Single Family Dwellings Data\_Snohomish County.pdf

New	REFEE WAS APPLIED TO THIS PERMIT IN ERROR - Should be 00-104906RK (jls) Refund request s	2001
New	2516 sf rambler w/616 sf garage and 40 sf covered porch	2001
New	Approved Basic #00-110350 BP Plan: 2605 Two Story SFR - 1997 UBC	2001
New	2-story style SFR....1997 UBC	2001
New	3097 sf 2-story w/886 sf garage and 54 sf covered porch	2001
New	2625 sf 2-story w/760 sf garagem 108 sf covered deck/porch and 108 sf open deck	2001
New	2590 sf 2-story w/35 sf covered entry and 677 sf garage	2001
New	Two Story SFR with Attached Garage	2001
New	Approved Basic #00-110693 BP Bldrs Plan No. 2421 Two-story SFR.....1997 UI	2001
New	Two Story SFR - 1997 UBC Plan: 491 A	2001
New	Two Story SFR - 1997 UBC Plan: 488 2a	2001
New	Approved Basic #01-101113 BP Plan: 491 B Two Story SFR - 1997 UBC	2001
New	Two Story SFR - 1997 UBC Plan: 498 2a	2001
New	Two Story SFR - 1997 UBC Plan: 488 2b	2001
New	Approved Basic #01-100110 BP Plan: 488 2a Two Story SFR - 1997 UBC	2001
New	Two Story SFR - 1997 UBC	2001
New	Approved Basic #01-106082 BP Plan: 2195-0 One-story SFR w/finished base	2001
New	Approved Basic #98-109315BP Split SFR w/finished lower floor - 1997 UBC	2001
New	SFR w/finished basement - 1997 UBC Plan: 2195-0	2001
New	Approved Basic #01-106934 BP Plan: 2100 SFR w/finished lower floor - 1997 U	2001
New	1354 s.f. w/809 s.f. finished basement & 2 car garage	2001
New	Approved Basic #00-110392 BP Builders Plan 2407 Daylight SFR w/finished baseme	2001
New	Approved Basic #01-106738 BP Plan #2088 Split entry SFR w/ attached 2 car	2001
New	Approved Basic #01-106738 BP Plan #2088 Split entry SFR w/ attached 2 car	2001
New	Approved Basic #01-104227 BP Plan: 1969 Two Story SFR - 1997 UBC	2001
New	Approved Basic #01-107794BP Plan #2100-B Mid entry SFR - 1997 UBC	2001
New	SFR w/finished lower floor - 1997 UBC	2001
New	Approved Basic #00-110392 BP Builders Plan 2407 Daylight SFR w/finished baseme	2001
New	Approved Basic #98-109303BP Split SFR w/finished lower floor - 1997 UBC	2001
New	Approved Basic #01-106082 BP Plan: 2195-0 One-story SFR w/finished base	2001
New	Approved Basic #01-106738 BP Plan #2088 Split entry SFR w/ attached 2 car	2001
New	Approved Basic #01-104228 BP Plan: 2407-0 SFR w/finished basement - 1997 UB	2001
New	Approved Basic #01-104228 BP Plan: 2407-0 SFR w/finished basement - 1997 UB	2001
New	Approved Basic #01-106082 BP Plan: 2195-0 One-story SFR w/finished base	2001
New	Approved Basic #00-108551 BP Plan: 2127 w/basement Two Story SFR w/finishec	2001
New	Approved Basic #00-110392 BP Builders Plan 2407 Daylight SFR w/finished baseme	2001
New	Approved Basic #01-104227 BP Plan: 1969 Two Story SFR - 1997 UBC	2001
New	Approved Basic #98-109303BP Split SFR w/finished lower floor - 1997 UBC	2001
New	Split entry SFR w/ attached 2 car garage	2001
New	Approved Basic #00-108551 BP Plan: 2127 w/basement Two Story SFR w/finishec	2001
New	Approved Basic #01-100111 BP Plan: 488 2b Two Story SFR - 1997 UBC	2001
New	Two Story SFR - 1997 UBC Plan: 491 B	2001
New	Approved Basic #01-100110 BP Plan: 488 2a Two Story SFR - 1997 UBC	2001
New	Approved Basic #01-100111 BP Plan: 488 2b Two Story SFR - 1997 UBC	2001
New	Approved Basic #00-110465 BP Plan: 1725 Hip Two Story SFR - 1997 UBC	2001
New	2070 s.f. w/1220 s.f. finished basement & 2 car garage	2001
New	Approved Basic #01-101112 BP Plan: 491 A Two Story SFR - 1997 UBC	2001

Accessory Dwelling Units

Index # - File Name: 1.0022 - Single Family Dwellings Data\_Snohomish County.pdf

New	Approved Basic #01-100110 BP	Plan: 488 2a Two Story SFR - 1997 UBC	2001
New	Approved Basic #01-101113 BP	Plan: 491 B Two Story SFR - 1997 UBC	2001
New	Approved Basic #01-100111 BP	Plan: 488 2b Two Story SFR - 1997 UBC	2001
New	Approved Basic #00-109738 BP	Plan: 1725 Gable Two Story SFR - 1997 UBC	2001
New	Approved Basic #00-110128BP	Plan # M1528A2F-1 Two Story SFR -1997 UBC	2001
New	Approved Basic #00-110465 BP	Plan: 1725 Hip Two Story SFR - 1997 UBC	2001
New	Approved Basic #00-110128BP	Plan # M1528A2F-1 Two Story SFR - 1997 UBC	2001
New	27 x 56 2000 Fleetwood		2001
New	Approved Basic #99-109776 BP	Plan: 2397 w/bonus Two Story SFR - 1997 UBC	2001
New	Approved Basic 99105003 BP	Builders Plan 9410-A Two-story SFR w/	2001
New	Approved Basic 99105003 BP	Builders Plan 9410-A Two-story SFR w/	2001
New	Approved Basic 99105003 BP	Builders Plan 9410-A Two-story SFR w/	2001
New	2-story style SFR....1997 UBC		2001
New	Approved Basic #99-112673 BP	Plan: 3272 Two Story SFR - 1997 UBC	2001
New	Approved Basic #99-104638BP	Plan: 2274 Rambler Style SFR - 1997 UBC OPTI	2001
New	Approved Basic #01-101257 BP	Plan: 2233 - D Two Story SFR - 1997 UBC	2001
New	Approved Basic #99-109776 BP	Plan: 2397 w/bonus Two Story SFR - 1997 UBC	2001
New	Approved Basic #99-110535 BP	Plan: 2834 Two Story SFR - 1997 UBC 1st Opti	2001
New	Approved Basic #99-109776 BP	Plan: 2397 w/bonus Two Story SFR - 1997 UBC	2001
New	2-story style SFR....1997 UBC		2001
New	Approved Basic #00-110370 BP	Plan: 2233 Two Story SFR - 1997 UBC	2001
New	Approved Basic #99-112673 BP	Plan: 3272 Two Story SFR - 1997 UBC	2001
New	Approved Basic #00-110371 BP	Plan: 2233 - B Two Story SFR - 1997 UBC	2001
New	Approved Basic #99-110535 BP	Plan: 2834 Two Story SFR - 1997 UBC 1st Opti	2001
New	Approved Basic #99-104638BP	Plan: 2274 Rambler Style SFR - 1997 UBC OPTI	2001
New	Approved Basic #99-112673 BP	Plan: 3272 Two Story SFR - 1997 UBC	2001
New	SENT TO MICROFICHE 5/22/06 ssullivan	Rambler w/ 3 Car	2001
New	Approved Basic #00-109312 BP	Plan: Avalon Two Story SFR - 1997 UBC	2001
New	Two Story SFR - 1997 UBC	Plan: 1710/Capri	2001
New	Approved Basic #00-109312 BP	Plan: Avalon Two Story SFR - 1997 UBC	2001
New	Approved Basic #00-107241 BP	Plan: 1988 Two Story SFR - 1997 UBC	2001
New	Approved Basic #00-109312 BP	Plan: Avalon Two Story SFR - 1997 UBC	2001
New	2-story style SFR...1997 UBC		2001
New	Approved Basic #00-109312 BP	Plan: Avalon Two Story SFR - 1997 UBC	2001
New	Approved Basic #00-109312 BP	Plan: Avalon Two Story SFR - 1997 UBC	2001
New	Approved Basic #01-105980 BP	Plan: 2256/Chateau Two Story SFR - 1997 UBC	2001
New	Approved Basic #00-107241 BP	Plan: 1988 Two Story SFR - 1997 UBC	2001
New	Approved Basic #00-109314 BP	Plan: 1755/Parkside Two Story SFR....1997 UBC	2001
New	Two Story SFR - 1997 UBC		2001
New	4013 SF SFR w/ 756 SF garage		2001
New	2948 SF SFR with garage		2001
New	1997 40 6 x 60 Golden Manor - Golden West		2001
New	Approved Basic #00-109316 BP	Plan: Waterbrooke Two Story SFR - 1997 U	2001
New	Approved Basic #00-107241 BP	Plan: 1988 Two Story SFR - 1997 UBC	2001
New	***STOP WORK PER G. SCHELBRACK, 12/11/01***	Approved Basic #01-111025 BP	Plan 2001
New	Approved Basic #00-109312 BP	Plan: Avalon Two Story SFR - 1997 UBC	2001
New	Approved Basic #00-108299 BP	Plan: 1922/Covington Two Story SF	2001

Accessory Dwelling Units

Index # - File Name: 1.0022 - Single Family Dwellings Data\_Snohomish County.pdf

New	Approved Basic #00-108299 BP	Plan: 1922/Covington	Two Story SF	2001
New	Approved Basic #00-109315 BP	Plan: Brookside	Two Story SFR....1997 UBC	2001
New	Approved Basic #00-109314 BP	Plan: 1755/Parkside	Two Story SFR....1997 UBC	2001
New	2 story w/2 car garage			2001
New	Approved Basic #01-111025 BP	Plan: #1993 The Mayfair	Two Story SFR - 1997 UBC	2001
New	Approved Basic #01-111025 BP	Plan: #1993 The Mayfair	Two Story SFR - 1997 UBC	2001
New	Two Story SFR - 1997 UBC			2001
New	Split Level SFR - 1997 UBC	Plan: 1570		2001
New	Approved Basic #01-104462 BP	Plan: 1570	Split Level SFR - 1997 UBC	2001
New	Approved Basic #01-101075 BP	Plan: 1576	Two Story SFR - 1997 UBC	2001
New	Approved Basic #01-104462 BP	Plan: 1570	Split Level SFR - 1997 UBC	2001
New	Approved Basic #01-101075 BP	Plan: 1576	Two Story SFR - 1997 UBC	2001
New	Two Story SFR with Attached Garage			2001
New	Two Story SFR with Attached Garage			2001
New	1521 Sf SFR w/attached garage			2001
New	1521 SF SFR w/ attached garage			2001
New	2 story SFR with attached garage			2001
New	2 story SFR with attached garage			2001
New	2 Story w/ Unfinished Basement & 3 Car			2001
New	3650 sf 2-story w/784 sf garage, 42 sf covered deck/porch and 200sf patio			2001
New	One-story SFR w/attached garage			2001
New	2 story sfr w/2 car garage			2001
New	Two-story SFR			2001
New	Tri- level SFR w/unfinished basement & garage 1997 UBC			2001
New	2200SF SFR W/Garage.....1997 UBC			2001
New	Two-story SFR with attached garage...1997 UBC			2001
New	2200SF SFR W/Garage.....1997 UBC			2001
New	Approved Basic #01-107263 BP	Plan: 2180	Two Story SFR....1997 UBC	2001
New	Two Story SFR - 1997 UBC		Plan: 2108	2001
New	2-story style SFR....1997 UBC			2001
New	2 Story w/ 3 Car			2001
New	3118 SF SFR w/garage			2001
New	2140 SF SFR W/Garage			2001
New	Two Story SFR - 1997 UBC	Plan: 2342		2001
New	1778 SF SFR w/garage			2001
New	2555 SF SFR w/3 car garage			2001
New	Two Story SFR - 1997 UBC	Plan: 2180/Timberlake		2001
New	Rambler with Attached Garage			2001
New	Two Story SFR - 1997 UBC	Plan: 2032/Timberlake		2001
New	SFR w/ garage			2001
New	2-story style SFR.....1997 UBC			2001
New	Approved Basic #00-106367 BP	Plan: 1705 crawl	SFR w/finished lower floor	2001
New	Approved Basic #98-150447BP	Plan: 1223	Rambler Style SFR - 1997 UBC	2001
New	Approved Basic #00-106450 BP	Plan: 1567 Revised	Tri-Level SFR - 1997 UBC	2001
New	Two Story SFR - 1997 UBC			2001
New	Two Story SFR - 1997 UBC	Plan: 1554		2001
New	Approved Basic #00-106811 BP	Plan: 1644 slab/revised	Split Level SFR - 1997 UI	2001



Accessory Dwelling Units

Index # - File Name: 1.0022 - Single Family Dwellings Data\_Snohomish County.pdf

New	Approved Basic #01-104235 BP	Plan: 1573 Two Story SFR - 1997 UBC	2001
New	Approved Basic #00-106367 BP	Plan: 1705 crawl SFR w/finished lower floor	2001
New	Approved Basic #01-104521 BP	Plan: 1680 E/2 Gable Two Story SFR - 1997 UBC	2001
New	Approved Basic #01-105212 BP	Plan: 1538 Two Story SFR - 1997 UBC	2001
New	Approved Basic #98-150447 BP	Plan: 1223 Rambler Style SFR - 1997 UBC	2001
New	Approved Basic #01-104521 BP	Plan: 1680 E/2 Gable Two Story SFR - 1997 UBC	2001
New	Approved Basic #01-104235 BP	Plan: 1573 Two Story SFR - 1997 UBC	2001
New	Approved Basic #01-106982 BP	Plan: 1705 crawl (revised) SFR w/finished lower floor	2001
New	Approved Basic #00-106811 BP	Plan: 1644 Slab Split Level SFR - 1997 UBC	2001
New	Approved Basic #01-106982 BP	Plan: 1705 crawl (revised) SFR w/finished lower floor	2001
New	Approved Basic #01-105743 BP	Plan: 1644 crawl Split Level SFR - 1997 UBC	2001
New	Approved Basic #01-104235 BP	Plan: 1573 Two Story SFR - 1997 UBC	2001
New	Approved Basic #01-106982 BP	Plan: 1705 crawl (revised) SFR w/finished lower floor	2001
New	Approved Basic #01-104235 BP	Plan: 1573 Two Story SFR - 1997 UBC	2001
New	Approved Basic #01-105212 BP	Plan: 1538 Two Story SFR - 1997 UBC	2001
New	Approved Basic #00-106367 BP	Plan: 1705 crawl SFR w/finished lower floor	2001
New	Approved Basic #00-106450 BP	Plan: 1567 Revised Tri-Level SFR - 1997 UBC	2001
New	Approved Basic #01-104521 BP	Plan: 1680 E/2 Two Story SFR - 1997 UBC	2001
New	Approved Basic #01-104235 BP	Plan: 1573 Two Story SFR - 1997 UBC	2001
New	Approved Basic #00-106367 BP	Plan: 1705 crawl SFR w/finished lower floor	2001
New	Approved Basic #01-104235 BP	Plan: 1573 Two Story SFR - 1997 UBC	2001
New	Approved Basic #00-106367 BP	Plan: 1705 crawl SFR w/finished lower floor	2001
New	Approved Basic #98-150447BP	Plan: 1223 Rambler Style SFR	2001
New	Approved Basic #00-101321 BP	Plan: 1632 Two Story SFR - 1997 UBC	2001
New	Approved Basic #99-116416 BP	Plan: 1567 Tri-Level SFR - 1997 UBC	2001
New	Approved Basic #99-101587BP	2 Story SFR/ 2 car garage	Plan # 2001
New	Approved Basic #99-101587BP	2 Story SFR/ 2 car garage	Plan # 2001
New	Approved Basic #98-150447BP	Plan: 1223 Rambler Style SFR - 1997 UBC	2001
New	Approved Basic #01-106982 BP	Plan: 1705 crawl (revised) SFR w/finished lower floor	2001
New	Approved Basic #01-104521 BP	Plan: 1680 E/2 Two Story SFR - 1997 UBC	2001
New	Approved Basic #01-104235 BP	Plan: 1573 Two Story SFR - 1997 UBC	2001
New	Approved Basic #98-109408BP	Plan: 1705 slab SFR w/finished lower floor - 1	2001
New	Approved Basic #00-106367 BP	Plan: 1705 crawl SFR w/finished lower floor	2001
New	Approved Basic #01-104235 BP	Plan: 1573 Two Story SFR - 1997 UBC	2001
New	Approved Basic #01-106982 BP	Plan: 1705 crawl (revised) SFR w/finished lower floor	2001
New	Approved Basic #01-104235 BP	Plan: 1573 Two Story SFR - 1997 UBC	2001
New	Approved Basic #01-106982 BP	Plan: 1705 crawl (revised) SFR w/finished lower floor	2001
New	Approved Basic #01-104235 BP	Plan: 1573 Two Story SFR - 1997 UBC	2001
New	Approved Basic #01-106982 BP	Plan: 1705 crawl (revised) SFR w/finished lower floor	2001
New	Approved Basic #01-104235 BP	Plan: 1573 Two Story SFR - 1997 UBC	2001
New	Approved Basic #01-105743 BP	Plan: 1644 crawl Split Level SFR - 1997 UBC	2001
New	Approved Basic #01-106982 BP	Plan: 1705 crawl (revised) SFR w/finished lower floor	2001
New	Approved Basic #01-104235 BP	Plan: 1573 Two Story SFR - 1997 UBC	2001
New	Approved Basic #98-150447BP	Plan: 1223 Rambler Style SFR - 1997 UBC	2001
New	Approved Basic #01-106982 BP	Plan: 1705 crawl (revised) SFR w/finished lower floor	2001
New	Approved Basic #01-104235 BP	Plan: 1573 Two Story SFR - 1997 UBC	2001
New	Approved Basic #98-109410BP	Plan: 1644 slab & crawl Split Level SFR - 1997	2001

Accessory Dwelling Units

Index # - File Name: 1.0022 - Single Family Dwellings Data\_Snohomish County.pdf

New	Approved Basic #01-104235 BP	Plan: 1573 Two Story SFR - 1997 UBC	2001
New	Approved Basic #98-150447BP	Plan: 1223 Rambler Style SFR - 1997 UBC	2001
New	Approved Basic #98-109408BP	Plan: 1705 slab SFR w/finished lower floor - 1	2001
New	Approved Basic #00-106811 BP	Plan: 1644 revised Split Level SFR - 1997 UBC	2001
New	Approved Basic #00-106367 BP	Plan: 1705 crawl SFR w/finished lower floor	2001
New	Approved Basic #98-150447BP	Plan: 1223 Rambler Style SF	2001
New	Approved Basic #98-150447BP	Plan: 1223 Rambler Style SF	2001
New	Approved Basic #98-150447BP	Plan: 1223 Rambler Style SF	2001
New	Approved Basic #98-150447BP	Plan: 1223 Rambler Style SF	2001
New	Approved Basic #00-106450 BP	Plan: 1567 Revised Tri-Level SFR - 1997 UBC	2001
New	Approved Basic #01-105212 BP	Plan: 1538 Two Story SFR - 1997 UBC	2001
New	2500 sf rambler w/752 sf garage, 53 sf covered entry and 260 sf patio		2001
New	Approved Basic #99-104574BP	Plan: Kirkwood Rambler Style SFR - 1997 UBC	2001
New	Approved Basic #99-116397 BP	Plan: Trisha - Mid-Entry Mid-Entry Style SFR w/fir	2001
New	Approved Basic #98-116510BP	Plan: 1610 C/2 Two-story SFR - 1997 UBC	2001
New	Approved Basic #99-116397 BP	Plan: Trisha - Mid-Entry Mid-Entry Style SFR w/fir	2001
New	Approved Basic #99-104574BP	Plan: Kirkwood Rambler Style SFR - 1997 UBC	2001
New	Approved Basic #98-116510BP	Plan: 1610 C/2 Two-story SFR - 1997 UBC	2001
New	Approved Basic #99-116397 BP	Plan: Trisha - Mid-Entry Mid-Entry Style SFR w/fir	2001
New	Approved Basic #99-116397 BP	Plan: Trisha - Mid-Entry Mid-Entry Style SFR w/fir	2001
New	Approved Basic #99-104574BP	Plan: Kirkwood Rambler Style SFR - 1997 UBC	2001
New	Approved Basic #99-116397 BP	Plan: Trisha - Mid-Entry Mid-Entry Style SFR w/fir	2001
New	Approved Basic #98-116510BP	Plan: 1610 C/2 Two-story SFR - 1997 UBC	2001
New	Approved Basic #99-116397 BP	Plan: Trisha - Mid-Entry Mid-Entry Style SFR w/fir	2001
New	Approved Basic #98-116510BP	Plan: 1610 C/2 Two-story SFR - 1997 UBC	2001
New	Approved Basic #99-104694BP	Plan: Georgetown Two Story SFR - 1997 UBC	2001
New	Approved Basic #99-116397 BP	Plan: Trisha - Mid-Entry Mid-Entry Style SFR w/fir	2001
New	Approved Basic #98-116510BP	Plan: 1610 C/2 Two-story SFR - 1997 UBC	2001
New	Approved Basic #99-116397 BP	Plan: Trisha - Mid-Entry Mid-Entry Style SFR w/fir	2001
New	Approved Basic #99-104694BP	Plan: Georgetown Two Story SFR - 1997 UBC	2001
New	Approved Basic #99-104574BP	Plan: Kirkwood Rambler Style SFR	2001
New	Approved Basic #99-116397 BP	Plan: Trisha - Mid-Entry Mid-Entry Style SFR w/fir	2001
New	Approved Basic #98-116510BP	Plan: 1610 C/2 Two-story SFR - 1997 UBC	2001
New	Approved Basic #99-116397 BP	Plan: Trisha - Mid-Entry Mid-Entry Style SFR w/fir	2001
New	Approved Basic #99-104574BP	Plan: Kirkwood Rambler Style SFR	2001
New	2-story style SFR....1997 UBC		2001
New	Rambler style SFR w/bonus room above 3-car garage...1997 UBC		2001
New	1008 SF SFR		2001
New	Approved Basic #01-106276 BP	Plan #9514 w/bonus room Two Story SFR - 1997	2001
New	2 story sfr w/3 car garage		2001
New	Approved Basic #01-106276 BP	Plan #9514 w/bonus room Two Story SFR - 1997	2001
New	1754 s.f. w/1063 s.f. finished basement & 3 car garage		2001
New	2 story sfr w/3 car garage		2001
New	3141 SF SFR/Garage		2001
New	Two-story SFR w/semi-finished basement		2001
New	2 story SFR w/ attached 3 car garage		2001
New	One-story SFR w/attached garage		2001

Accessory Dwelling Units

Index # - File Name: 1.0022 - Single Family Dwellings Data\_Snohomish County.pdf

New	2 story sfr w/unfinished basement & 3 car garage		2001
New	Two story SFR w/attached garage		2001
New	Two-story SFR with attached garage with bonus room - 1997 UBC		2001
New	Mid-entry style SFR...1997 UBC		2001
New	Approved Basic 01-111225 BP	PLAN #2098 Mid-entry style SFR...1997 U	2001
New	Approved Basic #98-107885BP	Plan: #1908/side Two Story SFR - 1997 UBC	2001
New	Approved Basic #01-107781 BP	Plan No. 2191 Two-story SFR.....1997 UBC	2001
New	Approved Basic #01-108235 BP	Plan: 2274 Two Story SFR - 1997 UBC	2001
New	Approved Basic # 01-107775 BP	Plan No. 2343 Two Story SFR...1997 UBC	2001
New	Approved Basic #99-103777BP	Plan: 2415 A/3 Two Story SFR - 1997 UBC	2001
New	Approved Basic #01-108235 BP	Plan: 2274 Two Story SFR - 1997 UBC	2001
New	Approved Basic #00-106097 BP	Plan: 2415 Two Story SFR - 1997 UBC	2001
New	Approved Basic #01-103877 BP	Plan #2297 \$60 RE-FEE Two-story SFR - 1	2001
New	Approved Basic # 01-107775 BP	Plan No. 2343 2-story style SFR....1997 UBC	2001
New	Approved Basic #99-103777BP	Plan: 2415 A/3 Two Story SFR - 1997 UBC	2001
New	Approved Basic #99-116087 BP	Plan: 2637 (revised) Two Story SFR - 1997 U	2001
New	Approved Basic #00-106097 BP	Plan: 2415 Two Story SFR - 1997 UBC	2001
New	Approved Basic #00-103949 BP	Plan: 2415 Two Story SFR - 1997 UBC	2001
New	Approved Basic #99-115755 BP	Two Story SFR - 1997 UBC Plan: 227	2001
New	Two Story SFR - 1997 UBC	Plan: Cambridge/2486	2001
New	Approved Basic #00-106939 BP	Plan: 2390 Two Story SFR - 1997 UBC	2001
New	Approved Basic #01-100253 BP	Plan: 2386 Two Story SFR - 1997 UBC	2001
New	Approved Basic #98-150959BP	Two Story SFR w/unfinished basement - 1997 UBC	2001
New	Approved Basic #98-150959BP	Two Story SFR w/unfinished basement - 1997 UBC	2001
New	Approved Basic #00-103949 BP	Plan: 2415 Two Story SFR - 1997 UBC	2001
New	Approved Basic #01-103877 BP	Plan #2297 Two-story SFR.....1997 UBC	2001
New	Approved Basic #00-105956 BP	Plan: Brittany Two Story SFR - 1997 UBC	2001
New	Approved Basic #01-103756 BP	Plan: 2750 Berkeley Two Story SFR - 1997 UBC	2001
New	Approved Basic #00-103049 BP	Plan: 2076 Two Story SFR - 1997 UBC	2001
New	Approved Basic #00-104974 BP	Plan: 2461 revised Two Story SFR - 1997 UBC	2001
New	Approved Basic #00-103949 BP	Plan: 2415 Two Story SFR - 1997 UBC	2001
New	Approved Basic #00-107245 BP	Plan: 2052 - front load (revised) Two Story SFR -	2001
New	Approved Basic #99-103777BP	Plan: 2415 A/3 Two Story SFR - 1997 UBC	2001
New	Approved Basic # 01-107775 BP	Plan No. 2343 2-story style SFR....1997 UBC	2001
New	Approved Basic #00-108901	Plan #2268 Two Story SFR.....1997 UBC	2001
New	2-story style SFR....1997 UBC		2001
New	Approved Basic #01-103877 BP	Plan #2297 Two-story SFR.....1997 UBC	2001
New	Approved Basic #01-103756 BP	Plan: 2750 Berkeley Two Story SFR - 1997 UBC	2001
New	Approved Basic #00-103949 BP	Plan: 2415 Two Story SFR - 1997 UBC	2001
New	Approved Basic #00-103049 BP	Plan: 2076 Two Story SFR - 1997 UBC	2001
New	Approved Basic #99-103777BP	Plan: 2415 A/3 Two Story SFR - 1997 UBC	2001
New	Approved Basic #00-106097 BP	Plan: 2415 Two Story SFR - 1997 UBC	2001
New	Approved Basic #99-103777BP	Plan: 2415 A/3 Two Story SFR - 1997 UBC	2001
New	Approved Basic #01-107009 BP	Plan: 2164 Two Story SFR - 1997 UBC	2001
New	Approved Basic #00-106097 BP	Plan: 2415 Two Story SFR - 1997 UBC	2001
New	Approved Basic #00-108899 BP	Plan: Brittany - revised Two Story SFR Basic....1!	2001
New	Approved Basic #99-103777BP	Plan: 2415 A/3 Two Story SFR - 1997 UBC	2001

Accessory Dwelling Units

Index # - File Name: 1.0022 - Single Family Dwellings Data\_Snohomish County.pdf

New	Approved Basic #01-110762 BP	Plan: 1922 Two Story SFR - 1997 UBC	2001
New	Approved Basic #01-108235 BP	Plan: 2274 Two Story SFR - 1997 UBC	2001
New	Approved Basic #00-103949 BP	Plan: 2415 Two Story SFR - 1997 UBC	2001
New	Approved Basic #00-106097 BP	Plan: 2415 Two Story SFR - 1997 UBC	2001
New	Approved Basic #00-104350 BP	Plan: 2535 A/3 Two Story SFR - 1997 UBC	2001
New	Approved Basic No. 00-104409 BP Rambler style SFR...1997 UBC	Bldrs Pla	2001
New	Two-story SFR with attached garage - 1997UBC		2001
New	One-story SFR w/attached garage		2001
New	Approved Basic No. 00-104409 BP Rambler style SFR...1997 UBC	Bldrs Pla	2001
New	Approved Basic #99-105443BP	Plan: 2339 Two Story SFR - 1997 UE	2001
New	Approved Basic #00-101994 BP	Plan: 2330 Two Story SFR - 1997 UBC	2001
New	2192 sf rambler w/704 sf garage and 36 sf covered deck/porch		2001
New	Two Story SFR with Attached Garage		2001
New	One-story SFR w/attached garage		2001
New	Approved Basic #00-102874 BP	Plan #00-01 Two Story SFR - 1997 UBC	2001
New	Rambler style SFR....1997 UBC		2001
New	Rambler style SFR.....1997 UBC		2001
New	Rambler style SFR.....1997 UBC		2001
New	2 story SFR w/ attached 3 car garage		2001
New	Approved Basic #01-104340 BP	Plan No. 2192 Rambler Style SFR.....1997 UBC	2001
New	Approved Basic #00-108050 BP	Plan 1910 SFR w/finished lower floor - 1997 U	2001
New	Approved Basic #00-108050 BP	Plan 1910 SFR w/finished lower floor - 1997 U	2001
New	Approved Basic #00-108050 BP	Plan 1910 SFR w/finished lower floor - 1997 U	2001
New	1994 Skyline 48 x 28 Convert Temporary Dwelling to full time Single Family Residence		2001
New	2 story sfr w/2 car garage		2001
New	2605 Sf SFR w/3 car garage		2001
New	Approved Basic #01-100583BP	Plan: 3162 Two Story SFR - 1997 UBC	2001
New	Approved Basic #01-100583BP	Plan: 3162 Two Story SFR - 1997 UBC	2001
New	2-story style SFR....1997 UBC	Builders Plan M2980A	2001
New	2-story style SFR....1997 UBC	Builders Plan M2980B	2001
New	Approved Basic #00-102589 BP	Plan: 2955 Two Story SFR - 1997 UBC	2001
New	Approved Basic #98-116126BP	Plan 2704 Two Story SFR - 1997 U	2001
New	Approved Basic #01-104038 BP	Plan: 2925 Two Story SFR - 1997 UBC	2001
New	Approved Basic #00-102589 BP	Plan: 2955 Two Story SFR - 1997 UBC	2001
New	Two Story SFR - 1997 UBC	Plan: 2925	2001
New	Approved Basic #98-116126BP	Plan 2704 Two Story SFR - 1997 U	2001
New	Approved Basic #01-100663 BP	Bldrs Plan No. M2780B3F-0 Two Story SFR - 1997 UB	2001
New	Approved Basic #01-100663 BP	Bldrs Plan No. M2780B3F-0 Two Story SFR - 1997 UB	2001
New	Approved Basic #01-104038 BP	Plan: 2925 Two Story SFR - 1997 UBC	2001
New	Approved Basic #01-104632 BP	Plan: M 2980 A4FT-0 Two Story SFR - 1997 UBC	2001
New	Approved Basic #01-106587 BP	Plan: #M2780B3FT-0 Two Story SFR - 1997 UBC	2001
New	Approved Basic #01-104632 BP	Plan: M2980 A4FT-0 Two Story SFR - 1997 UBC	2001
New	Approved Basic #01-106512 BP	Plan: M2980 B Two Story SFR - 1997 UBC	2001
New	Approved Basic #01-106587 BP	Plan #M2780B3FT-0 Two Story SFR - 1997 UBC	2001
New	Approved Basic #00-102589 BP	Plan: 2955 Two Story SFR - 1997 UBC	2001
New	Two-story SFR w/attached garage -	PLAN M2780	2001
New	Two Story SFR - 1997 UBC	Plan# M2780B3F-0	2001

Accessory Dwelling Units

Index # - File Name: 1.0022 - Single Family Dwellings Data\_Snohomish County.pdf

New	Approved Basic #01-101541BP	Plan: 2877 Two Story SFR - 1997 UBC	2001
New	Approved Basic #99-109495 BP	Plan: 2771 Two Story SFR - 1997 U	2001
New	Approved Basic #01-111809 BP	Plan: 2722 (Revised 2656) Rambler Style SFR w/bonus	2001
New	2 story sfr w/3 car garage		2001
New	2 Story w/ 3 Car		2001
New	Approved Basic #01-105400 BP	Plan: 463 A/B Two Story SFR - 1997 UBC	2001
New	Approved Basic #01-105410 BP	Plan: 467 B Two-story SFR - 1997 UBC	2001
New	Approved Basic #01-105400 BP	Plan: 463 A/B Two Story SFR - 1997 UBC	2001
New	Approved Basic #01-107370 BP	Plan No. 130-2 Rambler style SFR.....1997 UBC	2001
New	Approved Basic #01-105404 BP	Plan: 462 Two-story SFR - 1997 UBC	2001
New	Approved Basic #01-105404 BP	Plan: 462 Two-story SFR - 1997 UBC	2001
New	Approved Basic #01-105410 BP	Plan: 467 B Two-story SFR - 1997 UBC	2001
New	Approved Basic #01-105400 BP	Plan: 463 A/B Two Story SFR - 1997 UBC	2001
New	Two-story SFR with attached garage - 1997 UBC	Builder s Plan # 467-3(2)	2001
New	Two-story SFR - 1997 UBC	Plan #463 A	2001
New	Approved Basic #01-107370 BP	Plan No. 130-2 Rambler style SFR.....1997 UBC	2001
New	Two-story SFR with attached garage - 1997 UBC	Builder s Plan #462-3	2001
New	Two Story SFR - 1997 UBC	Plan: Sullivan	2001
New	Two Story SFR - 1997 UBC	Plan: Tayler	2001
New	1533 sf rambler w/440 sf garage and 20 sf covered deck/porch		2001
New	1533 sf rambler w/440 sf garage adn 20 sf covered deck/porch		2001
New	Approved Basic #01-101435 BP	Plan: 2598 Two Story SFR - 1997 UBC	2001
New	Approved Basic #99-103057BP	Plan: 2032 Two Story SFR - 1997 UBC	2001
New	Approved Basic #01-101434 BP	Plan: 2042 Two Story SFR - 1997 UBC	2001
New	Approved Basic #99-103056BP	Plan: 1740 Two Story SFR - 1997 UBC	2001
New	Approved Basic #01-101435 BP	Plan: 2598 Two Story SFR - 1997 UBC	2001
New	Approved Basic #99-103057BP	Plan: 2032 Two Story SFR - 1997 UBC	2001
New	Approved Basic #01-101438 BP	Plan: 2409 C Two Story SFR - 1997 UBC	2001
New	Approved Basic #01-101434 BP	Plan: 2042 Two Story SFR - 1997 UBC	2001
New	Approved Basic #01-101435 BP	Plan: 2598 Two Story SFR - 1997 UBC	2001
New	Approved Basic #99-103056BP	Plan: 1740 Two Story SFR - 1997 UBC	2001
New	Approved Basic #99-103057BP	Plan: 2032 Two Story SFR - 1997 UBC	2001
New	Approved Basic #99-103056BP	Plan: 1740 Two Story SFR - 1997 UBC	2001
New	Approved Basic #01-101438 BP	Plan: 2409 C Two Story SFR - 1997 UBC	2001
New	Approved Basic #01-101438 BP	Plan: 2409 C Two Story SFR - 1997 UBC	2001
New	Approved Basic #01-101434 BP	Plan: 2042 Two Story SFR - 1997 UBC	2001
New	Approved Basic #01-101434 BP	Plan: 2042 Two Story SFR - 1997 UBC	2001
New	Approved Basic #01-101434 BP	Plan: 2042 Two Story SFR - 1997 UBC	2001
New	Approved Basic #01-101438 BP	Plan: 2409 C Two Story SFR - 1997 UBC	2001
New	Approved Basic #01-101434 BP	Plan: 2042 Two Story SFR - 1997 UBC	2001
New	Approved Basic #01-101439 BP	Plan: 2409 A Two Story SFR - 1997 UBC	2001
New	Approved Basic #01-101434 BP	Plan: 2042 Two Story SFR - 1997 UBC	2001
New	Approved Basic #01-101439 BP	Plan: 2409 A Two Story SFR - 1997 UBC	2001
New	Approved Basic #01-101438 BP	Plan: 2409 C Two Story SFR - 1997 UBC	2001
New	Approved Basic #01-101435 BP	Plan: 2598 Two Story SFR - 1997 UBC	2001
New	Approved Basic #01-101438 BP	Plan: 2409 C Two Story SFR - 1997 UBC	2001
New	Approved Basic #01-101434 BP	Plan: 2042 Two Story SFR - 1997 UBC	2001

Accessory Dwelling Units

Index # - File Name: 1.0022 - Single Family Dwellings Data\_Snohomish County.pdf

New	Approved Basic #01-101435 BP	Plan: 2598 Two Story SFR - 1997 UBC	2001
New	Approved Basic #01-101435 BP	Plan: 2598 Two Story SFR - 1997 UBC	2001
New	Approved Basic #01-101438 BP	Plan: 2409 C Two Story SFR - 1997 UBC	2001
New	Approved Basic #01-101435 BP	Plan: 2598 Two Story SFR - 1997 UBC	2001
New	Approved Basic #01-101438 BP	Plan: 2409 C Two Story SFR - 1997 UBC	2001
New	Approved Basic #01-101435 BP	Plan: 2598 Two Story SFR - 1997 UBC	2001
New	Approved Basic #01-101434 BP	Plan: 2042 Two Story SFR - 1997 UBC	2001
New	Approved Basic #01-103531 BP	Plan: 1740/A Two Story SFR - 1997 UBC	2001
New	Approved Basic #01-106258 BP	Plan: 2032 - BL Two Story SFR - 1997 UBC	2001
New	Approved Basic #01-101434 BP	Plan: 2042 Two Story SFR - 1997 UBC	2001
New	Approved Basic #01-106258 BP	Plan: 2032-BL Two Story SFR - 1997 UBC	2001
New	Approved Basic #01-101439 BP	Plan: 2409 A Two Story SFR - 1997 UBC	2001
New	Approved Basic #01-101438 BP	Plan: 2409 C Two Story SFR - 1997 UBC	2001
New	Approved Basic #01-101434 BP	Plan: 2042 Two Story SFR - 1997 UBC	2001
New	Approved Basic #01-101439 BP	Plan: 2409 A Two Story SFR - 1997 UBC	2001
New	Approved Basic #01-101438 BP	Plan: 2409 C Two Story SFR - 1997 UBC	2001
New	Approved Basic #01-101438 BP	Plan: 2409 C Two Story SFR - 1997 UBC	2001
New	Approved Basic #01-101439 BP	Plan: 2409 A Two Story SFR - 1997 UBC	2001
New	Approved Basic #01-101434 BP	Plan: 2042 Two Story SFR - 1997 UBC	2001
New	Approved Basic #01-104891 BP	Plan: Rainier SFR w/finished lower floor - 1997 UBC	2001
New	Approved Basic #01-100282 BP	Plan 1784 B/2 Two Story SFR.....1997 UBC	2001
New	Approved Basic #01-101571 BP. FINALED ON COPY -- ORIG. PERMIT LOST.	Plan: 1680 A Two Story SFR.....1997 UBC	2001
New	Approved Basic #01-100481 BP	Plan 1680 A Two Story SFR.....1997 UBC	2001
New	Approved Basic #01-101569 BP	Plan: 1885 T/A Tri-Level SFR - 1997 UBC	2001
New	Approved Basic #00-109387 BP	Plan: 1715 Split Level SFR w/semi-finished low	2001
New	Approved Basic #00-109382 BP	Plan: 1567 Tri-level SFR - 1997 UBC	2001
New	Approved Basic #01-100282 BP	Plan 1784 B/2 Two Story SFR.....1997 UBC	2001
New	Two Story SFR - 1997 UBC	Plan: 1998 A/2-3	2001
New	Approved Basic #01-100282 BP	Plan 1784 B/2 Two Story SFR.....1997 UBC	2001
New	Approved Basic #00-109399 BP	Plan 1528 Two Story SFR.....1997 UBC	2001
New	Two Story SFR - 1997 UBC	Plan: 1465 A-2	2001
New	Approved Basic #00-109382 BP	Plan: 1567 Tri-Level SFR - 1997 UBC	2001
New	Approved Basic #01-101571 BP	Plan: 1644 crawl Split Level SFR - 1997 UBC	2001
New	Approved Basic #01-104888 BP	Plan: Baker A2 SFR w/finished basement - 1997 UBC	2001
New	Approved Basic #01-104460 BP	Plan 1784 A/2 Two Story SFR.....1997 UBC	2001
New	Approved Basic #00-109399 BP	Plan 1528 Two Story SFR.....1997 UBC	2001
New	Approved Basic # 00-109385 BP	Plan: 1705 crawl SFR w/finished lower floor	2001
New	Approved Basic #01-104891 BP	Plan: Rainier SFR w/finished lower floor - 1997 UBC	2001
New	Approved Basic #01-100282 BP	Plan 1784 B/2 Two Story SFR.....1997 UBC	2001
New	Approved Basic #01-100477 BP	Plan: 1465 A Two Story SFR - 1997 UBC	2001
New	Approved Basic #01-104888 BP	Plan: Baker A2 SFR w/finished basement - 1997 UBC	2001
New	Approved Basic #01-104460 BP	Plan 1784 A/2 Two Story SFR.....1997 UBC	2001
New	Approved Basic #01-104891 BP	Plan: Rainier SFR w/finished lower floor - 1997 UBC	2001
New	Approved Basic #01-101569 BP	Plan: 1885 T/A Tri-Level SFR - 1997 UBC	2001
New	Approved Basic #01-100477 BP	Plan: 1465 A Two Story SFR - 1997 UBC	2001
New	Approved Basic #00-109387 BP	Plan: 1715 Split Level SFR w/semi-finished low	2001
New	Approved Basic #01-101438 BP	Plan: 2409 C Two Story SFR - 1997 UBC	2001

Accessory Dwelling Units

Index # - File Name: 1.0022 - Single Family Dwellings Data\_Snohomish County.pdf

New	Approved Basic #01-101438 BP	Plan: 2409 C Two Story SFR - 1997 UBC	2001
New	Approved Basic #01-101435 BP	Plan: 2598 Two Story SFR - 1997 UBC	2001
New	Approved Basic #99-103057BP	Plan: 2032 Two Story SFR - 1997 UBC	2001
New	Approved Basic #01-101439 BP	Plan: 2409 A Two Story SFR - 1997 UBC	2001
New	Approved Basic #99-103057BP	Plan: 2032 Two Story SFR - 1997 UBC	2001
New	Approved Basic #99-103056BP	Plan: 1740 Two Story SFR - 1997 UBC	2001
New	Approved Basic #01-101438 BP	Plan: 2409 C Two Story SFR - 1997 UBC	2001
New	1403 sf rambler w/400 sf garage and 180 sf covered deck/porch		2001
New	1403 sf rambler w/400 sf garage and 180 sf covered deck/porch		2001
New	2 story sfr w/3 car garage		2001
New	20x40 1979 Goldenwest		2001
New	20 x 40 (1975) Kingswood		2001
New	Approved Basic #01-110578 BP	Plan: 2590 A Two Story SFR - 1997 UBC	2001
New	Approved Basic #00-100562 BP	Plan #2294 B2F-0 Two Story SFR - 1997 UBC	2001
New	Approved Basic #00-109209 BP	Plan 2146 Two Story SFR - 1997 UBC	2001
New	Approved Basic #01-100273 BP	Plan: 2054 Two Story SFR - 1997 UBC	2001
New	Two Story SFR - 1997 UBC	Plan: 2138	2001
New	Approved Basic #01-105987 BP	Plan: 2138 Two Story SFR - 1997 UBC	2001
New	Approved Basic #01-110578 BP	Plan: 2590 A Two Story SFR - 1997 UBC	2001
New	Two-story SFR w/attached garage		2001
New	Approved Basic #01-110576 BP	Plan: 1905 2/3 Two Story SFR - 1997 UBC	2001
New	2 story SFR with attached garage		2001
New	Approved Basic #01-100271 BP	Plan: 1987 Two Story SFR - 1997 UBC	2001
New	Approved Basic #01-107131 BP	Plan: 1855 Two Story SFR - 1997 UBC	2001
New	Approved Basic #00-109002 BP	Plan: 2008 A2 S-2 Two Story SFR - 1997 UBC	2001
New	Approved Basic #99-101442BP	Plan: M1974A2F-0 Two Story SFR with attached garage	2001
New	Approved Basic #01-100271 BP	Plan: 1987 Two Story SFR - 1997 UBC	2001
New	Approved Basic #99-114285 BP	Plan # Aspen 2 Two Story SFR - 1997 UBC	2001
New	Approved Basic #01-107131 BP	Plan: 1855 Two Story SFR - 1997 UBC	2001
New	Approved Basic #00-103631 BP	Plan: 1745 Two Story SFR - 1997 UBC	2001
New	4109 sf Tri-level w/832 sf attached garage, 318 sf covered deck/porch and 96 sf open deck		2001
New	Approved Basic #00-109209 BP	Plan 2146 Two Story SFR - 1997 UBC	2001
New	Approved Basic #00-109378 BP	Plan: 2388 Two Story SFR - 1997 UBC	2001
New	Approved Basic #01-100548 BP	Plan 2146 w/basement Two Story SFR w/finished	2001
New	Approved Basic #99-114285 BP	Plan # Aspen 2 Two Story SFR - 1997 UBC	2001
New	Two Story SFR - 1997 UBC	Plan: 2054	2001
New	Two Story SFR - 1997 UBC	Plan: 2033	2001
New	Approved Basic #99-114285 BP	Plan # Aspen 2 Two Story SFR - 1997 UBC	2001
New	Approved Basic #00-109207 BP	Plan #2294 A2 F-2 Two Story SFR - 1997 UBC	2001
New	Approved Basic #01-105986 BP	Plan: 2033 Two Story SFR - 1997 UBC	2001
New	Approved Basic #01-100273 BP	Plan: 2054 Two Story SFR - 1997 UBC	2001
New	Approved Basic #99-114285 BP	Plan # Aspen 2 Two Story SFR - 1997 UBC	2001
New	Approved Basic #00-109209 BP	Plan 2146 Two Story SFR - 1997 UBC	2001
New	Approved Basic #00-109207 BP	Plan #2294 A2 F-2 Two Story SFR - 1997 UBC	2001
New	Approved Basic #99-114285 BP	Plan # Aspen 2 Two Story SFR - 1997 UBC	2001
New	Approved Basic #00-100924 BP	Plan: 2405 Two Story SFR - 1997 UBC	2001
New	Approved Basic #01-105185 BP	Plan: 2415 Two Story SFR - 1997 UBC	2001

Accessory Dwelling Units

Index # - File Name: 1.0022 - Single Family Dwellings Data\_Snohomish County.pdf

New	Approved Basic #00-106939 BP	Plan: 2390 Two Story SFR - 1997 UBC	2001
New	Approved Basic #01-103753 BP	Plan: Avalon Two Story SFR - 1997 UBC	2001
New	Approved Basic #01-103753 BP	Plan: Avalon Two Story SFR - 1997 UBC	2001
New	2 Story w/ 2 Car		2001
New	2 story sfr w/2 car garage		2001
New	Two Story SFR - 1997 UBC	Plan: 2191	2001
New	Approved Basic #01-106324 BP	Plan: Berkeley Two Story SFR - 1997 UBC	2001
New	Two-story SFR with attached garage - 1997 UBC	Plan 2461	2001
New	Two-story SFR with attached garage -- 1997 UBC	Plan: 2415	2001
New	Two Story SFR - 1997 UBC	Plan: 2268	2001
New	Two Story SFR - 1997 UBC	Plan: 2415	2001
New	Two Story SFR - 1997 UBC	Plan: 2590	2001
New	Approved Basic #01-104903 BP	Plan: 2461 Two Story SFR - 1997 UBC	2001
New	Two Story SFR - 1997 UBC	Plan: 2343	2001
New	Approved Basic #01-105184 BP	Plan: 2268 Two Story SFR - 1997 UBC	2001
New	Approved Basic #01-106492 BP	Plan: 2590 Two Story SFR - 199 UBC	2001
New	Approved Basic #01-105185 BP	Plan: 2415 Two Story SFR - 1997 UBC	2001
New	Approved Basic #01-106822 BP	Plan: 2461 Two Story SFR - 1997 UBC	2001
New	Approved Basic #01-106822 BP	Plan: 2461 Two Story SFR - 1997 UBC	2001
New	Approved Basic #01-106492 BP	Plan: 2590 Two Story SFR - 199 UBC	2001
New	Approved Basic # 01-107775 BP	Plan No. 2343 2-story style SFR....1997 UBC	2001
New	Approved Basic #01-103756 BP	Plan: 2750 Berkeley Two Story SFR - 1997 UBC	2001
New	Approved Basic #99-103777BP	Plan: 2415 A/3 Two Story SFR - 1997 UBC	2001
New	Approved Basic #01-103756 BP	Plan: 2750 Berkeley Two Story SFR - 1997 UBC	2001
New	2784 s.f. sfr w/3 car garage		2001
New	Mid-entry style SFR.....1997 UBC		2001
New	Approved Basic #00-110128BP	Plan # M1528A2F-1 Two Story SFR -1997 UBC	2001
New	Approved Basic #01-105569 BP	Plan: 1632 SFR w/finished basement - 1997 UI	2001
New	Approved Basic #00-109738 BP	Plan: 1725 Gable Two Story SFR - 1997 UBC	2001
New	Approved Basic #00-110075 BP	Bldrs Plan No. 1676 Two Story - SFR.....1997 UBC	2001
New	Approved Basic #00-110465 BP	Plan: 1725 Hip Two Story SFR - 1997 UBC	2001
New	2 story sfr w/2 car garage		2001
New	Approved Basic #00-110128BP	Plan # M1528A2F-1 Two Story SFR -1997 UBC	2001
New	Approved Basic #00-110075 BP	Bldrs Plan No. 1676 Two Story - SFR.....1997 UBC	2001
New	Approved Basic #00-110128BP	Plan # M1528A2F-1 Two Story SFR -1997 UBC	2001
New	Approved Basic #00-110075 BP	Bldrs Plan No. 1676 Two Story - SFR.....1997 UBC	2001
New	Approved Basic #00-110465 BP	Plan: 1725 Hip Two Story SFR - 1997 UBC	2001
New	Approved Basic #00-110075 BP	Bldrs Plan No. 1676 Two Story - SFR.....1997 UBC	2001
New	Approved Basic #00-109738 BP	Plan: 1725 Gable Two Story SFR - 1997 UBC	2001
New	Approved Basic #00-109738 BP	Plan: 1725 Gable Two Story SFR - 1997 UBC	2001
New	Approved Basic #01-105569 BP	Plan: 1632 SFR w/finished basement - 1997 UI	2001
New	Approved Basic #00-110075 BP	Bldrs Plan No. 1676 Two Story - SFR.....1997 UBC	2001
New	Approved Basic #00-109738 BP	Plan: 1725 Gable Two Story SFR - 1997 UBC	2001
New	Approved Basic #00-110075 BP	Bldrs Plan No. 1676 Two Story - SFR.....1997 UBC	2001
New	Approved Basic #00-110465 BP	Plan: 1725 Hip Two Story SFR - 1997 UBC	2001
New	Approved Basic #00-110075 BP	Bldrs Plan No. 1676 Two Story - SFR.....1997 UBC	2001
New	Approved Basic #00-110128BP	Plan # M1528A2F-1 Two Story SFR -1997 UBC	2001



Accessory Dwelling Units

Index # - File Name: 1.0022 - Single Family Dwellings Data\_Snohomish County.pdf

New	Approved Basic #00-110075 BP	Bldrs Plan No. 1676	Two Story - SFR.....1997 UBC	2001
New	5/31/01 - STOP WORK ORDER ISSUED AT 1:44 P.M. BY GERRY SCHELBRACK FOR FAILURE TO MA			2001
New	Approved Basic #98-110563BP	Plan 2146	Two Story SFR - 1997 UBC	2001
New	Approved Basic No. 01-105681 BP	Bldrs Plan No. 1786	Two Story SFR - 1997 UBC	2001
New	Approved Basic #98-110563BP	Plan 2146	Two Story SFR - 1997 UBC	2001
New	Approved Basic #98-110563BP	Plan 2146	Two Story SFR - 1997 UBC	2001
New	Approved Basic #01-105681BP	Plan: 1786	Two Story SFR - 1997 UBC	2001
New	Approved Basic #98-110563BP	Plan 2146	Two Story SFR - 1997 UBC	2001
New	Approved Basic #01-105681BP	Plan: 1786	Two Story SFR - 1997 UBC	2001
New	Approved Basic No. 01-105681 BP	Bldrs Plan No. 1786	2-story style SFR w/ 2 car..	2001
New	Approved Basic #98-110563BP	Plan 2146	Two Story SFR - 1997 UBC	2001
New	Approved Basic No. 01-105681 BP	Bldrs Plan No. 1786	Two Story SFR - 1997 UBC	2001
New	Approved Basic #98-110563BP	Plan 2146	Two Story SFR - 1997 UBC	2001
New	One-story SFR w/semi-finished daylight basement			2001
New	Approved Basic #98-110563BP	Plan 2146	Two Story SFR - 1997 UBC	2001
New	Approved Basic No. 01-105681 BP	Bldrs Plan No. 1786	2-story style SFR w/ 2 car..	2001
New	Approved Basic #98-110563BP	Plan 2146	Two Story SFR - 1997 UBC	2001
New	Approved Basic #01-105569 BP	Plan: 1632	SFR w/finished basement - 1997 UI	2001
New	Approved Basic #01-105569 BP	Plan: 1632	SFR w/finished basement - 1997 UI	2001
New	Approved Basic #01-105569 BP	Plan: 1632	SFR w/finished basement - 1997 UI	2001
New	1282 w/614 unfinished basement w/2 car garage			2001
New	Approved Basic #01-107306 BP	Plan: 1689-A	Two Story SFR - 1997 UBC	2001
New	Approved Basic #01-107312 BP	Plan: 1731	Two Story SFR - 1997 UBC	2001
New	Approved Basic #01-105043 BP	Plan: 1689	Two Story SFR - 1997 UBC	2001
New	1731 sf 2-story w/414 sf garage, and 25 sf covered deck/porch			2001
New	1689 2-story w/473 sf garage, and 32 sf covered deck/porch			2001
New	Approved Basic #00-109209 BP	Plan 2146	Two Story SFR - 1997 UBC	2001
New	Approved Basic #00-109378 BP	Plan: 2388	Two Story SFR - 1997 UBC	2001
New	Approved Basic #00-109207 BP	Plan #2294 A2 F-2	Two Story SFR - 1997 UBC	2001
New	Approved Basic #01-110578 BP	Plan: 2590 A	Two Story SFR - 1997 UBC	2001
New	Approved Basic #01-110576 BP	Plan: 1905 2/3	Two Story SFR - 1997 UBC	2001
New	Approved Basic No. 01-105681 BP	Bldrs Plan No. 1786	Two Story SFR - 1997 UBC	2001
New	2 story sfr w/2 car garage			2001
New	Two-story SFR w/attached garage			2001
New	Approved Basic #01-106945 BP	Plan: 2265 C/2-3	Two Story SFR - 1997 UBC	2001
New	Approved Basic #01 106944 BP	Builders Plan M2102A2F-0	Two-story SFR - 1997 UE	2001
New	2 story w/3 car garage			2001
New	Two Story SFR - 1997 UBC	Plan: 2744		2001
New	Two Story SFR - 1997 UBC	Plan: M 2250 A2S-1		2001
New	Approved Basic #00-109590 BP	Plan: 2744	Two Story SFR - 1997 UBC	2001
New	Two Story SFR - 1997 UBC	Plan: M 2535 A3 F-0		2001
New	Two-story SFR w/finished basement.			2001
New	Approved Basic #01-100355 BP	Plan: M 2535 A3 F-0	Two Story SFR - 1997 UBC	2001
New	Approved Basic #00-100563 BP	Plan #1927	Two Story SFR - 1997 UBC	2001
New	Approved Basic #00-100562 BP	Plan #2294 B2F-0	Two Story SFR - 1997 UBC	2001
New	Approved Basic #00-100563 BP	Plan #1927	Two Story SFR - 1997 UBC	2001
New	Approved Basic #00-100562 BP	Plan #2294 B2F-0	Two Story SFR - 1997 U	2001

Accessory Dwelling Units

Index # - File Name: 1.0022 - Single Family Dwellings Data\_Snohomish County.pdf

New	Approved Basic #00-100563 BP	Plan #1927	Two Story SFR - 1997 UBC	2001
New	Two-story SFR with attached garage - 1997UBC			2001
New	1905 s.f. rambler w/3 car garage			2001
New	Two-story SFR w/attached garage			2001
New	Approved Basic #01-100481 BP	Plan 1680 A	Two Story SFR.....1997 UBC	2001
New	Approved Basic #01-101571 BP	Plan: 1644 crawl	Split Level SFR - 1997 UBC	2001
New	2 story sfr w/unfinished basement.....1997 UBC			2001
New	2-story style SFR.....1997 UBC			2001
New	Two Story SFR - 1997 UBC	PlanL M 2201	A3FT-1	2001
New	Two Story SFR with Attached Garage			2001
New	Approved Basic #99-112836 BP	Plan: #2461	Two Story SFR - 1997	2001
New	Two Story SFR - 1997 UBC	Plan: #2655	A/3-1	2001
New	Approved Basic #01-104364 BP	Plan No. 2581	Two-story style SFR.....1997 UBC	2001
New	Approved Basic #01-104366 BP	Plan: 2461 3 B/C	Two Story SFR - 1997 UBC	2001
New	Approved Basic #01-104364 BP	Plan No. 2581	Two-story SFR.....1997 UBC	2001
New	Approved Basic #01-105257 BP	Plan #2135R/3	Rambler Style SFR - 1997 UBC	2001
New	Approved Basic #01-105848 BP	Plan #2338A3ft-2	Two Story SFR.....1997 UBC	2001
New	Rambler Style SFR - 1997 UBC	Plan: 2135	R/3	2001
New	Approved Basic #01-104366 BP	Plan: 2461 3 B/C	Two Story SFR - 1997 UBC	2001
New	Approved Basic #01-105848 BP	Plan #2338A3ft-2	Two Story SFR with Attached	2001
New	Approved Basic #01-104366 BP	Plan: 2461 3 B/C	Two Story SFR - 1997 UBC	2001
New	Approved Basic 01-111012 BP	Plan: #2655	A/3-1 Two Story SFR - 1997 UBC	2001
New	2 story w/3 car garage			2001
New	Approved Basic #01-104943 BP	Plan: 2595-3	Two Story SFR - 1997 UBC	2001
New	Two Story SFR with Attatched Garage			2001
New	Approved Basic #01-104366 BP	Plan: 2461-3 B/C	Two Story SFR - 1997 UBC	2001
New	Approved Basic #01-104354 BP	Plan: 2415 B F-1	Two Story SFR - 1997 UBC	2001
New	Approved Basic #01-105257 BP	Plan #2135R/3	Rambler Style SFR - 1997 UBC	2001
New	Tri-Level SFR - 1997 UBC	Plan: 1391		2001
New	1937 sf 2-story w/440 sf garage w/120 sf covered deck/porch			2001
New	Approved Basic #00-110867 BP	Plan: 552	Two Story SFR - 1997 UBC	2001
New	Approved Basic #00-110868 BP	Plan: 553	Two Story SFR - 1997 UBC	2001
New	Approved Basic #00-110871 BP	Plan: 556	Two Story SFR - 1997 UBC	2001
New	Approved Basic #00-110870 BP	Plan: 555	Two Story SFR - 1997 UBC	2001
New	Approved Basic #00-110869 BP	Plan: 554	Two Story SFR - 1997 UBC	2001
New	Approved Basic #00-110868 BP	Plan: 553	Two Story SFR - 1997 UBC	2001
New	Approved Basic #01-111509 BP		Two Story SFR - 1997 UBC	2001
New	2-Story Log Home & retaining wall			2001
New	Two Story SFR - 1997 UBC	Plan: 2275		2001
New	Two-story SFR w/attached garage			2001
New	Approved Basic #01-105005 BP	Bldrs 1800 2/3	Two Story SFR.....1997 UBC	2001
New	1491 sf rambler w/913 sf finished basement w 495 sf garage, 69 sf covered porch and 175 sf op			2001
New	Approved Basic #01-104789 BP	Plan: 1491	SFR w/finished lower floor - 1997 U	2001
New	Two Story SFR w/finished lower floor - 1997 UBC	Plan: 2222		2001
New	STOP WORK ORDER ISSUED 11/16/01 @1:30PM BY GERRY SCHELBRACK FOR FAILURE TO PROVI			2001
New	2 story sfr w/finished basement & 2 car garage			2001
New	Two-story SFR w/attached garage			2001

Accessory Dwelling Units

Index # - File Name: 1.0022 - Single Family Dwellings Data\_Snohomish County.pdf

New	Two Story SFR w/finished lower floor - 1997 UBC	Plan: 2161	2001
New	Approved Basic #00-104827 BP	Plan: 2551 Two Story SFR - 1997 UBC	2001
New	Two-story SFR - 1997 UBC		2001
New	3230 sf 2-story w/1660 sf finished basement w/798 sf garage, 48 sf covered porch and 140 sf open deck		2001
New	2112 sf 2-story w/445 sf garage and 178 sf covered deck/porch		2001
New	4300sf SFR with attached garage -- 1997 UBC		2001
New	900 sf rambler		2001
New	Split Level SFR with attached garage		2001
New	Approved Basic #01 101235 BP	Builders Plan 1295 Two Story SFR - 1997 UBC	2001
New	Two-story SFR w/attached garage		2001
New	Approved Basic #99-113070 BP	Plan: 2083 Two Story SFR - 1997 UBC	2001
New	Approved Basic #98-110722BP	Two Story SFR - 1997 UBC	Plan #22 2001
New	Approved Basic #98-150653BP	Plan: #1938 B Two Story SFR - 1997	2001
New	27x66 (2001) Marlette		2001
New	Two-story SFR w/unfinished basement		2001
New	Two Story SFR with Attached Garage		2001
New	2702 SF SFR w/2 car garage		2001
New	Two Story SFR - 1997 UBC		2001
New	27x58 Marlette (2001)		2001
New	27x58 Marlette (2001)		2001
New	27x50 Casa del Rio Marlette (2001)		2001
New	Two-story SFR w/attached garage		2001
New	One-story SFR w/attached garage		2001
New	2 Story SFR W/Garage		2001
New	37 X 60 1992 Fuqua		2001
New	Approved Basic #99-113971 BP	Plan: 1315 Split Level SFR - 1997 UBC	2001
New	Approved Basic #99-113971 BP	Plan: 1315 Split Level SFR - 1997 UBC	2001
New	Approved Basic #01-103405 BP	Two Story Duplex - 1997 UBC	2001
New	2516 sf 2-story DUPLEX w/856 sf garage, 36 sf covered deck/porch and 160 sf open deck		2001
New	2664 sf 2-story DUPLEX w/826 sf garage, 36 sf covered deck/porch and 160 sf open deck		2001
New	Approved Basic #01-103405 BP	Two Story Duplex - 1997 UBC	2001
New	2000 Marlette Distinction 54 x 26		2001
New	2 story sfr		2001
New	2-story w/unfinished basement & attached garage.....1997 UBC		2001
New	Approved Basic #99-110071 BP	Plan: #2368 Two Story SFR - 1997 UBC	2001
New	2452 SF Duplex		2001
New	Approved Basic #01-101373 BP	Plan: 2415-3 Two Story SFR - 1997 UBC	2001
New	2 story SFR with bonus room over garage		2001
New	Approved Basic #01-101373 BP	Plan: 2415-3 Two Story SFR - 1997 UBC	2001
New	Approved Basic #00-107585 BP	Plan: #2343 Two Story SFR - 1997 UBC	2001
New	Two-story SFR w/attached garage		2001
New	1296 sf 2-story w/224 sf open deck		2001
New	Approved Basic No. 01-100428 BP	Plan: 2342-3 Two Story SFR - 1997 UBC	2001
New	3574 sf 2-story w/945 sf garage, 80 sf covered deck/porch and 190 sf patio		2001
New	3717sf 2-story SFR with attached 3-car garage - 1997 UBC		2001
New	Two Story SFR - 1997 UBC		2001
New	28 x 70 - 1999 - Fleetwood		2001

Accessory Dwelling Units

Index # - File Name: 1.0022 - Single Family Dwellings Data\_Snohomish County.pdf

New	2-story SFR w/semi-finished basement & attached 3-car garage...1997 UBC		2001
New	Two-story SFR w/attached garage		2001
New	One-story SFR with attached garage -- 1997 UBC		2001
New	SFR w/unfinished basement - 1997 UBC		2001
New	1980 s.f. w/3 car garage		2001
New	2117 sf SFR		2001
New	2-story SFR w/semi-finished basement...1997 UBC		2001
New	Approved Basic #99-109776 BP	Plan: 2397 w/bonus Two Story SFR - 1997 UBC	2001
New	Approved Basic #00-110371 BP	Plan: 2233 - B Two Story SFR - 1997 UBC	2001
New	Approved Basic #00-105892 BP	Plan: 4c Two Story SFR - 1997 UBC	2001
New	Approved Basic #00-104213 BP	Plan: 5 Two Story SFR - 1997 UBC	2001
New	Approved Basic #00-104216 BP	Plan: 2 Two Story SFR - 1997 UBC	2001
New	Two-story SFR w/attached garage		2001
New	2-story style SFR...1997 UBC		2001
New	2 story sfr w/3 car garage		2001
New	2415 sf 2-stroy w/630 sf garage, and 216 sf covered deck/porch		2001
New	Rambler Style SFR - 1997 UBC		2001
New	2272 s.f. rambler w/carport		2001
New	Two Story SFR - 1997 UBC		2001
New	72 x38 SFR w/Garage		2001
New	2509 sf 2-story w/1232 sf semi-finished basement, 91 sf covered deck/porch and 359 sf open de		2001
New	2 story sfr w/3 car garage		2001
New	2 story SFR with unfinished basement and attached garage		2001
New	1394 s.f. w/812 s.f. finished basement & 2 car garage		2001
New	2 story SFR with attached garage		2001
New	2 story SFR with unfinished basement		2001
New	2 story SFR w/ attached 3 car garage		2001
New	2-story style SFR w/366 sq ft covered porch.....1997 UBC		2001
New	Two-story with attached garage and unfinished bonus room - 1997 UBC		2001
New	2535 SF SFR w/3car garage		2001
New	Two-story SFR with attached garage - 1997 UBC		2001
New	2609 sf 2-story w/674 sf garage and 52 sf covered deck/porch		2001
New	SFR w/ attached garage		2001
New	002 story sfr w/1 car garage		2001
New	Rambler style SFR w/bonus room over 3-car garage...1997 UBC		2001
New	2 Story w/ 3 Car		2001
New	2 Story w/ 3 Car		2001
New	Ramble with Attached Garage - 1997 UBC		2001
New	Approved Basic #01-104211 BP	Plan: 1649 Rambler Style SFR - 1997 UBC	2001
New	Rambler Style SFR - 1997 UBC	Plan: Aspen	2001
New	Rambler Style SFR - 1997 UBC	Plan: Patrick	2001
New	Two Story SFR - 1997 UBC	Plan: Willow	2001
New	Two Story SFR - 1997 UBC	Plan: Everett	2001
New	Two Story SFR - 1997 UBC	Plan: Topeka	2001
New	Approved Basic #99-105206BP	Plan: 2934 Two Story SFR - 1997	2001
New	Approved Basic #01-103741 BP	Plan: Auburn Rambler Style SFR - 1997 UBC	2001
New	Approved Basic #01-103744 BP	Plan: Willow Two Style SFR - 1997 UBC	2001

Accessory Dwelling Units

Index # - File Name: 1.0022 - Single Family Dwellings Data\_Snohomish County.pdf

New	Approved Basic #01-103742 BP	Plan: Patrick	Rambler Style SFR - 1997 UBC	2001
New	Approved Basic #01-103737 BP	Plan: Topeka	Two Story SFR - 1997 UBC	2001
New	Approved Basic #01-103741 BP	Plan: Auburn	Rambler Style SFR - 1997 UBC	2001
New	1575 sf rambler w/484 sf garage and 176 sf covered deck/porch			2001
New	Rambler Style SFR - 1997 UBC			2001
New	Approved Basic #01-104215 BP	Plan: 1789	Two Story SFR - 1997 UBC	2001
New	Approved Basic #01-104211 BP	Plan: 1649	Rambler Style SFR - 1997 UBC	2001
New	2588 SF SFR w/garage			2001
New	Rambler Style SFR - 1997 UBC	Plan: Aspen		2001
New	Two Story SFR - 1997 UBC	Plan: Colby		2001
New	Two Story SFR - 1997 UBC	Plan: Topeka		2001
New	Two Story SFR - 1997 UBC	Plan: Everett		2001
New	Rambler Style SFR - 1997 UBC	Plan: 1377 - B		2001
New	Two Story SFR - 1997 UBC	Plan: Colby		2001
New	Rambler Style SFR - 1997 UBC	Plan: Patrick		2001
New	Two-story SFR w/attached garage			2001
New	Two story style SFR.....1997 UBC			2001
New	Approved Basic #01-105639BP	Plan #2640	Two Story SFR - 1997 UBC	2001
New	2660 sf 2-story w/688 sf garage			2001
New	One-story SFR w/unfinished basement			2001
New	3835 SF Rambler w/756 SF Gar./ 1178 SF Covered Deck/Porch and 2308 SF open deck.			2001
New	2-story SFR w/3-car garage & storage above the garage....1997 UBC			2001
New	Approved Basic #00-108051 BP	Plan: #1818/Getchell	Rambler style SFR 1997 UBC	2001
New	1701 sf 2-story w/536 sf garage, and 104 sf covered deck/porch			2001
New	Approved Basic #00-108051 BP	Plan: #1818/Getchell	Rambler style SFR 1997 UBC	2001
New	2 story sfr w/2 car garage			2001
New	1596 2-story w/454 sf garage, and 146 sf covered deck/porch			2001
New	Approved Basic #00-108051 BP	Plan: #1818/Getchell	Rambler style SFR 1997 UBC	2001
New	Two-story SFR w/attached garage			2001
New	2 story sfr w/2 car garage			2001
New	Approved Basic #01-104211 BP	Plan: 1649	Rambler Style SFR - 1997 UBC	2001
New	Approved Basic #01-104215 BP	Plan: 1789	Two Story SFR - 1997 UBC	2001
New	Rambler Style SFR - 1997 UBC	Plan: 1649		2001
New	Approved Basic #01-106641 BP	Plan: KayDee	Rambler Style SFR - 1997 UBC	2001
New	Rambler Style SFR - 1997 UBC	Plan: 1377 - B		2001
New	Two Story SFR - 1997 UBC	Plan: Willow		2001
New	Two Story SFR - 1997 UBC	Plan: Everett		2001
New	Two Story SFR - 1997 UBC	Plan: Colby		2001
New	Two Story SFR - 1997 UBC	Plan: Topeka		2001
New	Approved Basic #01-111199 BP		Rambler style SFR with attached garage 1997 UBC	2001
New	Two Story SFR - 1997 UBC	Plan: 1789		2001
New	Rambler Style SFR - 1997 UBC	Plan: Aspen		2001
New	Two Story SFR - 1997 UBC	Plan: Colby		2001
New	Approved Basic #01-103742 BP	Plan: Patrick	Rambler Style SFR - 1997 UBC	2001
New	Rambler Style SFR - 1997 UBC	Plan: Patrick		2001
New	28x40 SF 1985 Fleetwood			2001
New	Approved Basic #98-1162BP	Plan 1744	Tri-Level SFR - 1997 UBC	2001

Accessory Dwelling Units

Index # - File Name: 1.0022 - Single Family Dwellings Data\_Snohomish County.pdf

New	Approved Basic #98-116237 BP	Plan 8812	Tri-Level SFR - 1997 UBC	2001
New	Approved Basic #98-116233BP	Tri level SFR w/finished lower floor - 1997 UBC	Plar	2001
New	Approved Basic #00-108117 BP	Plan 1528	Two Story SFR.....1997 UBC	2001
New	Approved Basic #00-106279 BP	Plan 1805	Two Story SFR.....1997 UBC	2001
New	Approved Basic #00-106278 BP	Plan 1528	Two Story SFR.....1997 UBC	2001
New	Approved Basic #00-106278 BP	Plan 1528	Two Story SFR.....1997 UBC	2001
New	Approved Basic #00-108117 BP	Plan 1528	Two Story SFR.....1997 UBC	2001
New	Approved Basic #98-116233BP	Tri level SFR w/finished lower floor - 1997 UBC	Plar	2001
New	Approved Basic #00-106278 BP	Plan 1528	Two Story SFR.....1997 UBC	2001
New	Approved Basic #98-116235BP	Plan 8812	Tri-Level SFR - 1997	2001
New	Approved Basic #00-108117 BP	Plan 1528	Two Story SFR.....1997 UBC	2001
New	Approved Basic #00-108117 BP	Plan 1528	Two Story SFR.....1997 UBC	2001
New	Approved Basic #00-108117 BP	Plan 1528	Two Story SFR.....1997 UBC	2001
New	Approved Basic #98-116236BP	Plan 1744	Tri-Level SFR - 1997	2001
New	Approved Basic #98-116233BP	Tri level SFR w/finished lower floor - 1997 UBC	Plar	2001
New	Approved Basic #98-116236BP	Plan 1744	Tri-Level SFR - 1997	2001
New	Approved Basic #98-116236BP	Plan 1744	Tri-Level SFR - 1997	2001
New	Approved Basic #00-108117 BP	Plan 1528	Two Story SFR.....1997 UBC	2001
New	Approved Basic #99-101802BP	Plan: 1450 S	SFR w/finished basement - 1997	2001
New	Approved Basic #00-106279 BP	Plan 1805	Two Story SFR.....1997 UBC	2001
New	Approved Basic #00-108117 BP	Plan 1528	Two Story SFR.....1997 UBC	2001
New	Approved Basic #98-116233BP	Tri level SFR w/finished lower floor - 1997 UBC	Plar	2001
New	Approved Basic #98-116236BP	Plan 1744	Tri-Level SFR - 1997	2001
New	2368 sf 2-story w/1266 sf unfinished basement, 617 sf garage and 410 sf open deck			2001
New	Two Story SFR - 1997 UBC			2001
New	Two Story SFR with Attached Garage			2001
New	Approved Basic #98-109153BP	Plan 2031	Two Story SFR - 1997 UI	2001
New	Approved Basic #00-110376 BP	Plan 1833 w/bonus & nook	Two Story SFR - 1997 UB	2001
New	2372 sf 2-story w/790 sf garage, 32 sf covered deck/porch, and 80 sf open deck			2001
New	2309 sf rambler w/749 sf garage , 56 sf covered deck/porch and 80 sf open deck			2001
New	Two Story SFR - 1997 UBC			2001
New	2539 2-story w/691 unfinished basement, 790 sf garage, 30 sf covered deck/porch and 45 sf open deck			2001
New	Approved Basic #00-110376 BP	Plan 1833 w/bonus & nook	Two Story SFR - 1997 UB	2001
New	1705 s.f. rambler w/3 car garage			2001
New	Approved Basic No. 00-110621 BP	Bldrs Plan No. 2060 2-car	Two-story style SFR....	2001
New	Approved Basic #00-110159 BP	Plan: 2031 2 1/2 car w/basement	Two Story SFR \	2001
New	2 story sfr w/3 car garage			2001
New	Approved Basic #99-102335BP	Plan 1833 w/bonus	Two Story SFR - 1997 UBC	2001
New	Approved Basic #00-110376 BP	Plan: 1833 w/bonus & nook	Two Story SFR - 1997 UI	2001
New	Approved Basic #99-104694BP	Plan: Georgetown	Two Story SFR - 1997 UBC	2001
New	Approved Basic #98-116510BP	Plan: 1610 C/2	Two-story SFR - 1997 UBC	2001
New	Two Story SFR - 1997 UBC			2001
New	Approved Basic 01 104426 BP	Plan 1833 w/basement & 2nd story bumpout	Two Story SI	2001
New	Approved Basic #00-110376 BP	Plan 1833 w/bonus & nook	Two Story SFR - 1997 UB	2001
New	Approved Basic #99-116397 BP	Plan: Trisha - Mid-Entry	Mid-Entry Style SFR w/fir	2001
New	Approved Basic #98-116510BP	Plan: 1610 C/2	Two-story SFR - 1997 UBC	2001
New	Approved Basic #99-104574BP	Plan: Kirkwood	Rambler Style SFR	2001

Accessory Dwelling Units

Index # - File Name: 1.0022 - Single Family Dwellings Data\_Snohomish County.pdf

New	Approved Basic #99-116397 BP	Plan: Trisha - Mid-Entry	Mid-Entry Style SFR w/fir	2001
New	Approved Basic #99-116397 BP	Plan: Trisha - Mid-Entry	Mid-Entry Style SFR w/fir	2001
New	Approved Basic #99-116397 BP	Plan: Trisha - Mid-Entry	Mid-Entry Style SFR w/fir	2001
New	Approved Basic #99-116397 BP	Plan: Trisha - Mid-Entry	Mid-Entry Style SFR w/fir	2001
New	Approved Basic #00-109157 BP	Plan: Rainier w/finished lower floor/unfin. basement	Two Sto	2001
New	Approved Basic No. 00-107063 BP	Bldrs Plan No. 2119	2-story style SFR....1997 U	2001
New	Approved Basic #98-116510BP	Plan: 1610 C/2	Two-story SFR - 1997 UBC	2001
New	Approved Basic #99-116397 BP	Plan: Trisha - Mid-Entry	Mid-Entry Style SFR w/fir	2001
New	Approved Basic #99-104694BP	Plan: Georgetown	Two Story SFR - 1997 UBC	2001
New	1960 SF 2 Story SFR w/ garage			2001
New	Approved Basic #98-116510BP	Plan: 1610 C/2	Two-story SFR - 1997 UBC	2001
New	Approved Basic #99-104574BP	Plan: Kirkwood	Rambler Style SFR	2001
New	Approved Basic #99-104574BP	Plan: Kirkwood	Rambler Style SFR	2001
New	Approved Basic #99-104574BP	Plan: Kirkwood	Rambler Style SFR	2001
New	Approved Basic #98-116510BP	Plan: 1610 C/2	Two-story SFR - 1997 UBC	2001
New	Approved Basic #99-104694BP	Plan: Georgetown	Two Story SFR - 1997 UBC	2001
New	Approved Basic #98-116510BP	Plan: 1610 C/2	Two-story SFR - 1997 UBC	2001
New	Approved Basic #00-110418 BP	Plan: Cascade	SFR w/semi-finished basement - 199	2001
New	Approved Basic #00-110418 BP	Plan: Cascade	SFR w/semi-finished basement - 199	2001
New	Approved Basic #00-110418 BP	Plan: Cascade	SFR w/semi-finished basement - 199	2001
New	Approved Basic #99-116397 BP	Plan: Trisha - Mid-Entry	Mid-Entry Style SFR w/fir	2001
New	Approved Basic #99-116397 BP	Plan: Trisha - Mid-Entry	Mid-Entry Style SFR w/fir	2001
New	Approved Basic #99-104574BP	Plan: Kirkwood	Rambler Style SFR - 1997 UBC	2001
New	Approved Basic #01-1004977 BP	Plan 1960	Two-story SFR - 1997 UBC	2001
New	Approved Basic #00-110418 BP	Plan: Cascade	SFR w/semi-finished basement - 199	2001
New	Approved Basic #99-116397 BP	Plan: Trisha - Mid-Entry	Mid-Entry Style SFR w/fir	2001
New	Approved Basic #99-104694BP	Plan: Georgetown	Two Story SFR - 1997 UBC	2001
New	Approved Basic #01-100492 BP	Plan 2359	Two-story SFR w/attached garage	2001
New	Approved Basic #00-107069 BP	Bldrs Plan No. 2360	2-story style SFR.....1997	2001
New	Approved Basic #99-116397 BP	Plan: Trisha - Mid-Entry	Mid-Entry Style SFR w/fir	2001
New	Approved Basic #00-101971 BP	Plan: #2990 (Elev. C)	Two Story SFR - 1997 UBC	2001
New	Approved Basic #99-112258 BP	Plan: 3405 Elev. A	Two Story SFR - 1997 UBC	2001
New	Approved Basic #01-105493 BP	Plan: #2990 (Elev. B) - revised	Two Story SFR - 1997	2001
New	Approved Basic #99-112258 BP	Plan: 3405 Elev. A	Two Story SFR - 1997 UBC	2001
New	Approved Basic #00-109243 BP	Plan: 1836 Elev. C	Two Story SFR - 1997 UBC	2001
New	Approved Basic #01-105493 BP	Plan: #2990 (Elev. B) - revised	Two Story SFR - 1997	2001
New	Approved Basic #01-104492 BP	Plan: 2575 B - revised	Two Story SFR - 1997	2001
New	Approved Basic #99-112258 BP	Plan: 3405 Elev. A	Two Story SFR - 1997 UBC	2001
New	Approved Basic #01-105493 BP	Plan: #2990 (Elev. B) - revised	Two Story SFR - 1997	2001
New	Approved Basic #99-116397 BP	Plan: Trisha - Mid-Entry	Mid-Entry Style SFR w/fir	2001
New	Approved Basic #00-101970 BP	Plan: #2990 (Elev. B)	Two Story SFR - 1997 UBC	2001
New	Approved Basic #00-108821 BP	Plan: 1670 Elev. A	Two Story SFR - 1997 UBC	2001
New	Approved Basic #00-101967 BP	Plan: #2575 (Elev. B)	Two Story SFR - 1997 UBC	2001
New	28 x 50 , 2001 Oakwood			2001
New	Approved Basic #99-112258 BP	Plan: 3405 Elev. A	Two Story SFR - 1997 UBC	2001
New	Two Story SFR with 832 Sq Ft Semi - Finished Basement and Attached Garage			2001
New	Two Story SFR - 1997 UBC			2001

Accessory Dwelling Units

Index # - File Name: 1.0022 - Single Family Dwellings Data\_Snohomish County.pdf

New	Approved Basic #00-101967 BP	Plan: #2575 (Elev. B) Two Story SFR - 1997 UBC	2001
New	Approved Basic #99-109955 BP	Plan: 2148 Elev. B Two Story SFR - 1997	2001
New	Approved Basic #00-109063 BP	Plan: 1906 Elev. B Two Story SFR - 1997 UBC	2001
New	Approved Basic #00-109063 BP	Plan: 1906 Elev. B Two Story SFR - 1997 UBC	2001
New	Approved Basic #99-109807 BP	Plan: 2768 Two Story SFR - 1997 UBC	Of 2001
New	Approved Basic #99-109807 BP	Plan: 2768 Two Story SFR - 1997 UBC	Of 2001
New	Approved Basic #99-109807 BP	Plan: 2768 Two Story SFR - 1997 UBC	Of 2001
New	Approved Basic #01-104132 BP	Plan: 2895 Two Story SFR - 1997 UBC	2001
New	Approved Basic #01-103350 BP	Bldrs Plan No. 2990 Two-story style SFR.....19	2001
New	Approved Basic #99-109807 BP	Plan: 2768 Two Story SFR - 1997 UBC	2001
New	Two-story SFR		2001
New	Approved Basic #01-103350 BP	Bldrs Plan No. 2990 Two-story style SFR.....19	2001
New	Approved Basic #01-104898 BP	Plan #3166 Two Story style SFR.....1997 UBC	2001
New	Approved Basic #99-113027 BP	Plan: 2621 Two Story SFR - 1997 U	2001
New	Approved Basic #99-109807 BP	Plan: 2768 Two Story SFR - 1997 UBC	2001
New	Approved Basic #00-101970 BP	Plan: #2990 (Elev. B) Two Story SFR - 1997 UBC	2001
New	Approved Basic #99-112258 BP	Plan: 3405 Elev. A Two Story SFR - 1997 UBC	2001
New	4368 SF SFR w/ 1140 SF Garage		2001
New	Approved Basic #99-109806 BP	Plan: 2628 Two Story SFR - 1997 UBC	2001
New	Approved Basic #00-101974 BP	Plan: #2446 (Elev. C) Two Story SFR - 1997 UBC	2001
New	Approved Basic #00-101967 BP	Plan: #2575 (Elev. B) Two Story SFR - 1997 UBC	2001
New	Approved Basic #99-110099 BP	Plan: #2148 Elev. A Two Story SFR - 1997 UBC	2001
New	Approved Basic #00-101967 BP	Plan: #2575 (Elev. B) Two Story SFR - 1997 UBC	2001
New	Approved Basic #00-101972 BP	Plan: #2446 (Elev. A) Two Story SFR - 1997 UBC	2001
New	Approved Basic #99-109806 BP	Plan: 2628 Two Story SFR - 1997 UBC	2001
New	2397 SF SFR		2001
New	Approved Basic #00-109063 BP	Plan: 1906 Elev. B Two Story SFR - 1997 UBC	2001
New	Approved Basic #00-101974 BP	Plan: #2446 (Elev. C) Two Story SFR - 1997 UBC	2001
New	Two Story SFR - 1997 UBC	Plan: 2609 front load	2001
New	Approved Basic #00-101967 BP	Plan: #2575 (Elev. B) Two Story SFR - 1997 UBC	2001
New	Two-story SFR w/attached garage		2001
New	Approved Basic #01-104132 BP	Plan: 2895 Two Story SFR - 1997 UBC	2001
New	Approved Basic #99-113971 BP	Plan: 1315 Split Level SFR - 1997 UBC	2001
New	Approved Basic #01-105069 BP	Plan: #2446 (Elev. C) - revised Two Story SFR - 1997 UI	2001
New	Approved Basic #01-106017 BP	Plan: 2113 Elev. C - revised Two Story SFR - 1997 UE	2001
New	Approved Basic #01-105688 BP	Plan: #2990 (Elev. C) Porch Two Story SFR - 1997 UE	2001
New	Approved Basic #99-112258 BP	Plan: 3405 Elev. A Two Story SFR - 1997 UBC	2001
New	Approved Basic #01-105071 BP	Plan: 1906 Elev. B - revised Two Story SFR - 1997 U	2001
New	Approved Basic #01-105493 BP	Plan: #2990 (Elev. B) - revised Two Story SFR - 1997	2001
New	Approved Basic #00-108829 BP	Plan: 2113 Elev. A Two Story SFR - 1997 UBC	2001
New	Approved Basic #00-101968 BP	Plan: #2575 (Elev. C) Two Story SFR - 1997 UBC	2001
New	Approved Basic #99-112258 BP	Plan: 3405 Elev. A Two Story SFR - 1997 UBC	2001
New	Approved Basic #00-101971 BP	Plan: #2990 (Elev. C) Two Story SFR - 1997 UBC	2001
New	Approved Basic #00-108821 BP	Plan: 1670 Elev. A Two Story SFR - 1997 UBC	2001
New	Approved Basic #00-108823 BP	Plan: 1670 Elev. C Two Story SFR - 1997 UBC	2001
New	Approved Basic #00-109241 BP	Plan: 1836 Elev. B Two Story SFR - 1997 UBC	2001
New	Approved Basic #00-108821 BP	Plan: 1670 Elev. A Two Story SFR - 1997 UBC	2001



Accessory Dwelling Units

Index # - File Name: 1.0022 - Single Family Dwellings Data\_Snohomish County.pdf

New	Approved Basic #99-110099 BP	Plan: #2148 Elev A	Two Story SFR - 1997	2001
New	Approved Basic #00-101971 BP	Plan: #2990 (Elev. C)	Two Story SFR - 1997 UBC	2001
New	Approved Basic #00-101969 BP	Plan: #2990 (Elev. A)	Two Story SFR - 1997 UBC	2001
New	Approved Basic #00-101970 BP	Plan: #2990 (Elev. B)	Two Story SFR - 1997 UBC	2001
New	Approved Basic #00-101971 BP	Plan: #2990 (Elev. C)	Two Story SFR - 1997 UBC	2001
New	Approved Basic #00-101970 BP	Plan: #2990 (Elev. B)	Two Story SFR - 1997 UBC	2001
New	Approved Basic #00-101974 BP	Plan: #2446 (Elev. C)	Two Story SFR - 1997 UBC	2001
New	Approved Basic #00-101967 BP	Plan: #2575 (Elev. B)	Two Story SFR - 1997 UBC	2001
New	Approved Basic #00-108823 BP	Plan: 1670 Elev. C	Two Story SFR - 1997 UBC	2001
New	Approved Basic #99-110098 BP	Two Story SFR - 1997 UBC	Plan: #21	2001
New	Approved Basic #01-105072 BP	Plan: 1906 Elev. C - revised	Two Story SFR - 1997 U	2001
New	Approved Basic #99-110099 BP	Plan: #2148 Elev A	Two Story SFR - 1997	2001
New	Approved Basic #99-112258 BP	Plan: 3405 Elev. A	Two Story SFR - 1997 UBC	2001
New	Approved Basic #99-112259 BP	Plan: 3405 Elev. B	Two Story SFR - 19	2001
New	Approved Basic #00-109242 BP	Plan: 1836 Elev. A	Two Story SFR - 1997 UBC	2001
New	Approved Basic #99-115034 BP	Plan: 3319 Elv B	Two Story SFR - 1997 UB	2001
New	Approved Basic #00-101974 BP	Plan: #2446 (Elev. C)	Two Story SFR - 1997 UBC	2001
New	Approved Basic #99-115032 BP	Plan: 3319 Elv A	Two Story SFR - 19	2001
New	Approved Basic #00-101970 BP	Plan: #2990 (Elev. B)	Two Story SFR - 1997 UBC	2001
New	Two Story SFR - 1997 UBC	Plan: 1670 Elev. B		2001
New	Approved Basic #00-101966 BP	Plan: #2575 (Elev. A)	Two Story SFR - 1997 UBC	2001
New	Approved Basic #00-108821 BP	Plan: 1670 Elev. A	Two Story SFR - 1997 UBC	2001
New	Approved Basic #00-101971 BP	Plan: #2990 (Elev. C)	Two Story SFR - 1997 UBC	2001
New	Two Story SFR - 1997 UBC	Plan: 1670 Elev. A		2001
New	Approved Basic #00-101974 BP	Plan: #2446 (Elev. C)	Two Story SFR - 1997 UBC	2001
New	Approved Basic #99-110099 BP	Plan: 2148 (Elev A)	Two Story SFR - 1997 UBC	2001
New	Approved Basic #99-115034 BP	Plan: 3319 Elv B	Two Story SFR - 1997 UB	2001
New	Approved Basic #00-108821 BP	Plan: 1670 Elev. A	Two Story SFR - 1997 UBC	2001
New	Approved Basic #01-105688 BP	Plan: #2990 (Elev. C) Porch	Two Story SFR - 1997 UE	2001
New	Approved Basic #00-101970 BP	Plan: #2990 (Elev. B)	Two Story SFR - 1997 UBC	2001
New	Approved Basic #00-108823 BP	Plan: 1670 Elev. C	Two Story SFR - 1997 UBC	2001
New	Approved Basic #01-105494 BP	Plan: #2990 (Elev. C) - revised	Two Story SFR - 1997	2001
New	Approved Basic #99-114271 BP	Plan: 4202 B/C	Two Story SFR - 1997 UBC	2001
New	Approved Basic #00-104043 BP	Plan: 4105 C	Two Story SFR - 1997 UBC	2001
New	SFR - 1997 UBC			2001
New	44x27		2001 Marlette	2001
New	Approved Basic #99-115060 BP	Plan: B 409 D	Two Story SFR - 1997 UBC	2001
New	Approved Basic #00-105141 BP	Plan: G 519 B	Two Story SFR - 1997 UBC	2001
New	Approved Basic #00-103897 BP	Plan #B 410 A-SM	Two Story SFR - 1997 UB	2001
New	Approved Basic #00-109027 BP	Plan: G 519 A/larger porch	Two Story SFR - 1997 UB	2001
New	Approved Basic #00-109027 BP	Plan: G 519 A/larger porch	Two Story SFR - 1997 UB	2001
New	**STOP WORK ORDER POSTED 07/16/01 - EROSION CONTROL- GS 07/16/01***	Two-story SFR		2001
New	Two Story SFR - 1997 UBC	Plan: 315 A/B		2001
New	Approved Basic #99-115061 BP	Plan: B 107 A	Two Story SFR - :	2001
New	Approved Basic #00-106931 BP	Plan: 394 (2) B	Tri-Level Style SFR.....1997 UBC	2001
New	Approved Basic #00-103897 BP	Plan: B 410-SM	Two Story SFR - 1997 UBC	2001
New	Approved Basic #00-100773 BP	Plan: G 520-A	Two Story SFR - 1997 UBC	2001

Accessory Dwelling Units

Index # - File Name: 1.0022 - Single Family Dwellings Data\_Snohomish County.pdf

New	2 story sfr w/unfinished basement		2001
New	Two-story SFR w/attached garage		2001
New	Approved Basic #98-109460BP	Plan # A-311 a/b Two Story SFR - 1997 UB	2001
New	Approved Basic #00-105141 BP	Plan: G 519 B Two Story SFR - 1997 UBC	2001
New	Approved Basic #00-105047 BP	Plan # A-311 A Two Story SFR - 1997 UBC	2001
New	Approved Basic #01-104293 BP	Plan: G-521-B Two Story SFR - 1997 UBC	2001
New	Approved Basic #00-105048 BP	Plan # A-311 B Two Story SFR - 1997 UBC	2001
New	Approved Basic #00-103900 BP	Plan #G 521A SM Two Story SFR - 1997 UBC	2001
New	Approved Basic #01-104294 BP	Plan # A-311-A w/Media rm/small garage Two Story SF	2001
New	Approved Basic #00-109027 BP	Plan: G 519 A/larger porch Two Story SFR - 1997 UB	2001
New	Approved Basic #00-103900 BP	Plan #G 521A SM Two Story SFR - 1997 UBC	2001
New	Approved Basic #99-115060 BP	Plan: B 409 D Two Story SFR - 1	2001
New	Approved Basic #00-100774 BP	Two Story SFR - 1997 UBC Plan: 315 A/B	2001
New	Approved Basic #00-105047 BP	Plan # A-311 A Two Story SFR - 1997 UBC	2001
New	Approved Basic #01-104293 BP	Plan: G-521-B Two Story SFR - 1997 UBC C	2001
New	Approved Basic #00-105141 BP	Plan: G 519 B Two Story SFR - 1997 UBC	2001
New	Two-story SFR w/attached garage	Plan B 407 A II	2001
New	Approved Basic #00-103900 BP	Plan #G 521A SM Two Story SFR - 1997 UBC	2001
New	Approved Basic #00-100773 BP	Two Story SFR - 1997 UBC Plan: G 520-A	2001
New	Approved Basic #01-104293 BP	Plan: G-521-B Two Story SFR - 1997 UBC	2001
New	Approved Basic #00-109027 BP	Plan: G 519 A/larger porch Two Story SFR - 1997 UB	2001
New	Approved Basic #00-105047 BP	Plan # A-311 A Two Story SFR - 1997 UBC	2001
New	Approved Basic #00-109027 BP	Plan: G 519 A/larger porch Two Story SFR - 1997 UB	2001
New	Two Story SFR with Attached Garage - 1997 UBC		2001
New	Approved Basic #01-100389 BP	Plan: 2100 w/basement Two Story SFR w/semi-	2001
New	Two Story SFR w/semi finished basement - 1997 UBC	Plan: 2100 w/basement	2001
New	Approved Basic #01-100389 BP	Plan: 2100 w/basement Two Story SFR w/semi-	2001
New	Approved Basic #01-100389 BP	Plan: 2100 w/basement Two Story SFR w/semi-	2001
New	2871 2-story w/480 sf garage and 32 sf covered deck/porch		2001
New	2 story sfr w/3 car garage		2001
New	2-story SFR w/semi-finished basement.....1997 UBC		2001
New	Approved Basic #99-113971 BP	Plan: 1315 Split Level SFR - 1997 UBC	2001
New	Two-story SFR w/attached garage w/2nd story Bonus		2001
New	2425 s.f. rambler w/3 car garage		2001
New	30 x 70 1989 Fleetwood		2001
New	14x70 1974 Governor		2001
New	2 Story w/ Attached Garage		2001
New	30 x 70 1989 Fleetwood		2001
New	Split entry w 2 car - 1997UBC		2001
New	3388 sf 2-story w/800 sf attached garage and 225 sf covered deck/porch	CLOSED W/O FINAL. S	2001
New	Two Story SFR - 1997 UBC	Plan: 22115 B	2001
New	Two-story SFR w/attached garage		2001
New	2000 Fleetwood Anniversary 66 x 40		2001
New	2-story style SFR.....1997 UBC		2001
New	2-story SFR w/finished basement....1997 UBC		2001
New	30x60 2-story SFR...1997 UBC		2001
New	Two Story SFR with Finished Basement and Attached Garage		2001

Accessory Dwelling Units

Index # - File Name: 1.0022 - Single Family Dwellings Data\_Snohomish County.pdf

New	2655 sf 2-story w/1288 sf finished basement, 720 sf garage, 32 sf covered deck/porch and 320 s	2001
New	2 story SFR with daylight basement, attached garage and covered porch	2001
New	2 story sfr w/ 3 car attached garage	2001
New	Convert 384 sf unfinished basement in duplex to finished basement	2001
New	Two-story SFR w/attached garage	2001
New	2 story SFR with attached garage	2001
New	1720 sf 2-story w/1110 sf unfinished basement, 480 sf garage, 200 sf covered deck/porch w/320	2001
New	Approved Basic #99-103349BP Plan: 5318 Elev. A,B, & C Two Story SFR - 1997 UBC	2001
New	Approved Basic #99-101211BP Plan: 5023/5123 w/bonus rm Two Story SFR - 1997 UBC	2001
New	Approved Basic #99-101211BP Plan: 5023/5123 w/bonus rm Two Story SFR - 1997 UBC	2001
New	Approved Basic #99-101214BP Plan: 5223/5323 w/bonus rm Two Story SFR - 1997 UBC	2001
New	Approved Basic #99-103342BP Plan: 5222 Two Story SFR - 1997 UBC	2001
New	Approved Basic #99-114271 BP Plan: 4202 B/C Two Story SFR - 1997 UBC	2001
New	Approved Basic #99-103349BP Plan: 5318 Elev. A,B, & C Two Story SFR - 1997 UBC	2001
New	Approved Basic #99-103349BP Plan: 5318 Elev. A,B, & C Two Story SFR - 1997 UBC	2001
New	Approved Basic #99-103349BP Plan: 5318 Two Story SFR - 1997 UBC Op	2001
New	Approved Basic #99-103349BP Plan: 5318 Elev. A,B, & C Two Story SFR - 1997 UBC	2001
New	Approved Basic #99-103342BP Plan: 5222 Two Story SFR - 1997 UBC	2001
New	Approved Basic #00-103115 BP Plan: 4105 A Two Story SFR - 1997 UBC	2001
New	Approved Basic #99-101211BP Plan: 5023/5123 w/bonus rm Two Story SFR - 1997 UBC	2001
New	Approved Basic #99-103349BP Plan: 5318 Elev. A,B, & C Two Story SFR - 1997 UBC	2001
New	Approved Basic #99-103342BP Plan: 5222 Two Story SFR - 1997 UBC	2001
New	Approved Basic #99-101211BP Plan: 5023/5123 w/bonus rm Two Story SFR - 1997 UBC	2001
New	Approved Basic #99-114271 BP Plan: 4202 B/C Two Story SFR - 1997 UBC	2001
New	14 x 66 1982 Liberty Ridgewood	2001
New	2 story sfr w/2 car garage	2001
New	Approved Basic #00-108823 BP Plan: 1670 Elev. C Two Story SFR - 1997 UBC	2001
New	Two Story SFR - 1997 UBC	2001
New	Rambler w/ 2 Car	2001
New	Rambler with Attached Garage	2001
New	Rambler with Attached Garage	2001
New	Two-story SFR	2001
New	28x56, 2001 Redmond, #4563Q	2001
New	Daylight Rambler w/ 3 Car	2001
New	Approved Basic #99-113971 BP Plan: 1315 Split Level SFR - 1997 UBC	2001
New	Approved Basic #98-108806BP Plan 1936 Split 1174 sf SFR w/semi-fini	2001
New	Approved Basic #98-108803BP Plan 1750 Cal 1174 sf SFR w/semi-finished	2001
New	Approved Basic #01-113099 BP Plan 2193 Split level SFR - 1997 UBC	2002
New	Approved Basic #98-108803BP Plan 1750 Cal 1174 sf SFR w/semi-finished	2002
New	Approved Basic #98-108806BP Plan 1936 Split 1174 sf SFR w/semi-fini	2002
New	Approved Basic #98-108803BP Plan 1750 Cal 1174 sf SFR w/semi-finished	2002
New	Approved Basic #01-113099 BP Plan 2193 Split level SFR - 1997 UBC	2002
New	Approved Basic #98-108806BP Plan 1936 Split 1174 sf SFR w/semi-fini	2002
New	Approved Basic #98-108803BP Plan 1750 Cal 1174 sf SFR w/semi-finished	2002
New	Approved Basic #01-113099 BP Plan 2193 Split level SFR - 1997 UBC	2002
New	Approved Basic #98-108806BP Plan 1936 Split 1174 sf SFR w/semi-fini	2002
New	Approved Basic #98-108803BP Plan 1750 Cal 1174 sf SFR w/semi-finished	2002

Accessory Dwelling Units

Index # - File Name: 1.0022 - Single Family Dwellings Data\_Snohomish County.pdf

New	Approved Basic #01-113099 BP	Plan 2193 Split level SFR - 1997 UBC	2002
New	Approved Basic #98-108803BP	Plan 1771 Cal 1158 sf SFR w/semi-finished	2002
New	Approved Basic #98-108806BP	Plan 1936 Split 1174 sf SFR w/semi-fini	2002
New	Approved Basic #98-108806BP	Plan 1936 Split 1174 sf SFR w/semi-fini	2002
New	Approved Basic #98-108803BP	Plan 1771 Cal 1158 sf SFR w/semi-finished	2002
New	Approved Basic #98-108803BP	Plan 1771 Cal 1158 sf SFR w/semi-finished	2002
New	Approved Basic #98-108806BP	Plan 1936 Split 1174 sf SFR w/semi-fini	2002
New	Approved Basic #01-113099 BP	Plan 2193 Split level SFR - 1997 UBC	2002
New	Approved Basic #98-108803BP	Plan 1771 Cal 1158 sf SFR w/semi-finished	2002
New	Approved Basic #98-108806BP	Plan 1936 Split 1174 sf SFR w/semi-fini	2002
New	Approved Basic #01-113099 BP	Plan 2193 Split level SFR - 1997 UBC	2002
New	Approved Basic #98-108803BP	Plan 1771 Cal 1158 sf SFR w/semi-finished	2002
New	Rambler Style SFR - 1997 UBC		2002
New	Two Story SFR - 1997 UBC		2002
New	1826sf one-story SFR - 1997UBC		2002
New	2001sf one-story SFR - 1997 UBC		2002
New	Approved Basic #01-112901 BP	Bldrs Plan 1962 Rambler style SFR - 1997 UBC	2002
New	Approved Basic #01-112847 BP	Plan: 2250 Two Story SFR - 1997 UBC	2002
New	Approved Basic #01-104340 BP	Plan #2192 Rambler Style SFR.....1997 UBC	2002
New	2-Story SFR w/attached garage.		2002
New	Rambler w/ garage		2002
New	1 story SFR w/attached 3 car garage		2002
New	1 story SFR w/attached garage		2002
New	Rambler with Attached Garage		2002
New	Two Story SFR with Attached Garage		2002
New	2 Story w/ 3 Car		2002
New	1 story SFR w/ attached 2 car garage		2002
New	2 story SFR w/ attached garage		2002
New	2 story SFR w/attached garage		2002
New	Rambler Style SFR - 1997 UBC	Plan: 2274	2002
New	Rambler Style SFR - 1997 UBC	Plan: 1982	2002
New	Rambler Style SFR - 1997 UBC	Plan: 2274	2002
New	2 story SFR w/ attached garage		2002
New	Rambler Style SFR - 1997 UBC		2002
New	2 story SFR with attached garage		2002
New	Rambler w/3 car garage		2002
New	Approved Basic #00-104229 BP	Plan: 1533 revised Two Story SFR - 1997 UE	2002
New	Approved Basic #00-104229 BP	Plan: 1533 revised Two Story SFR - 1997 UE	2002
New	Approved Basic #02-102104-BP	Plan: 1420 - Rambler Rambler Style SFR - 1997 UBC	2002
New	Approved Basic #00-104229 BP	Plan: 1533 revised Two Story SFR - 1997 UE	2002
New	Approved Basic #02-102104-BP	Plan: 1420 - Rambler Rambler Style SFR - 1997 UBC	2002
New	Approved Basic #00-104229 BP	Plan: 1533 revised Two Story SFR - 1997 UE	2002
New	Approved Basic #02-102103-BP	Plan: 1014 - Rambler Rambler Style SFR - 1997 UBC	2002
New	Approved Basic #02-102103-BP	Plan: 1014 - Rambler Rambler Style SFR - 1997 UBC	2002
New	Approved Basic #02-102104-BP	Plan: 1420 - Rambler Rambler Style SFR - 1997 UBC	2002
New	Approved Basic #00-104229 BP	Plan: 1533 revised Two Story SFR - 1997 UE	2002
New	Approved Basic #02-102104-BP	Plan: 1420 - Rambler Rambler Style SFR - 1997 UBC	2002

Accessory Dwelling Units

Index # - File Name: 1.0022 - Single Family Dwellings Data\_Snohomish County.pdf

New	Rambler w/ 2 Car		2002
New	Approved Basic #02-102103-BP	Plan: 1014 - Rambler Rambler Style SFR - 1997 UBC	2002
New	Approved Basic #01-101769 BP	Plan: 1290 Two Story SFR - 1997 UBC	2002
New	Approved Basic #02-102103-BP	Plan: 1014 - Rambler Rambler Style SFR - 1997 UBC	2002
New	Approved Basic #02-102103-BP	Plan: 1014 - Rambler Rambler Style SFR - 1997 UBC	2002
New	Approved Basic #01-101769 BP	Plan: 1290 Two Story SFR - 1997 UBC	2002
New	Approved Basic #00-104229 BP	Plan: 1533 revised Two Story SFR - 1997 UE	2002
New	Approved Basic #00-104229 BP	Plan: 1533 revised Two Story SFR - 1997 UE	2002
New	Approved Basic #01-101769 BP	Plan: 1290 Two Story SFR - 1997 UBC	2002
New	Approved Basic #02-102103-BP	Plan: 1014 - Rambler Rambler Style SFR - 1997 UBC	2002
New	Approved Basic #02-102103-BP	Plan: 1014 - Rambler Rambler Style SFR - 1997 UBC	2002
New	Approved Basic #01-101769 BP	Plan: 1290 Two Story SFR - 1997 UBC	2002
New	Approved Basic #02-102103-BP	Plan: 1014 - Rambler Rambler Style SFR - 1997 UBC	2002
New	Approved Basic #02-102103-BP	Plan: 1014 - Rambler Rambler Style SFR - 1997 UBC	2002
New	Approved Basic #01-101769 BP	Plan: 1290 Two Story SFR - 1997 UBC	2002
New	Approved Basic #02-102103-BP	Plan: 1014 - Rambler Rambler Style SFR - 1997 UBC	2002
New	Approved Basic #02-102103-BP	Plan: 1014 - Rambler Rambler Style SFR - 1997 UBC	2002
New	Approved Basic #01-101769 BP	Plan: 1290 Two Story SFR - 1997 UBC	2002
New	Approved Basic #02-102103-BP	Plan: 1014 - Rambler Rambler Style SFR - 1997 UBC	2002
New	Approved Basic #02-102103-BP	Plan: 1014 - Rambler Rambler Style SFR - 1997 UBC	2002
New	Approved Basic #01-101769 BP	Plan: 1290 Two Story SFR - 1997 UBC	2002
New	Approved Basic #02-102103-BP	Plan: 1014 - Rambler Rambler Style SFR - 1997 UBC	2002
New	Approved Basic #02-102103-BP	Plan: 1014 - Rambler Rambler Style SFR - 1997 UBC	2002
New	Approved Basic #01-101769 BP	Plan: 1290 Two Story SFR - 1997 UBC	2002
New	Approved Basic #02-102103-BP	Plan: 1014 - Rambler Rambler Style SFR - 1997 UBC	2002
New	Approved Basic #01-101769 BP	Plan: 1290 Two Story SFR - 1997 UBC	2002
New	Approved Basic #01-101769 BP	Plan: 1290 Two Story SFR - 1997 UBC	2002
New	Approved Basic #00-102507 BP	Plan: 1290 Two Story SFR - 1997 UBC	2002
New	Rambler Style SFR with attached garage and covered porch		2002
New	Approved Basic #02-102103-BP	Plan: 1014 - Rambler Rambler Style SFR - 1997 UBC	2002
New	Approved Basic #02-102103-BP	Plan: 1014 - Rambler Rambler Style SFR - 1997 UBC	2002
New	2 Story w/ Unfin Basement & 3 Car Garage		2002
New	Approved Basic #01-113099 BP	Plan 2193 Split level SFR - 1997 UBC	2002
New	Approved Basic #98-108803BP	Plan 1750 Cal 1174 sf SFR w/semi-finished	2002
New	Approved Basic #01-113099 BP	Plan 2193 Split level SFR - 1997 UBC	2002
New	Approved Basic #98-108806BP	Plan 1936 Split 1174 sf SFR w/semi-fini	2002
New	Approved Basic #98-108803BP	Plan 1750 Cal 1174 sf SFR w/semi-finished	2002
New	Approved Basic #01-113099 BP	Plan 2193 Split level SFR - 1997 UBC	2002
New	Approved Basic #01-107318 BP	Plan: 2492 R/A/3 Rambler Style SFR - 1997 UBC	2002
New	Approved Basic #99-113246 BP	Plan: 2632 Two Story SFR - 1997 UB	2002
New	Approved Basic #98-150984BP	Plan: 5911-B Two Story SFR - 1997 UBC	2002
New	2-Story SFR w/attached Breezeway and two story Garage/Bonus room.		2002
New	One-story SFR - 1997UBC		2002
New	2580 sf 2-story w/648 sf garage and 64 sf covered porch		2002
New	1550 sf 2-story w/650 sf unfinished basement, 365 sf garage, 27 sf covered deck/porch and 80 s		2002
New	Two Story SFR w/semi-finished basement - 1997 UBC	Plan: 1404	2002
New	Two Story SFR w/semi-finished basement - 1997 UBC	Plan: 1404	2002

Accessory Dwelling Units

Index # - File Name: 1.0022 - Single Family Dwellings Data\_Snohomish County.pdf

New	Approved Basic #01-101344 BP	Plan: 1460 S SFR w/finished lower floor - 1997 UBC	2002
New	Approved Basic #02-100245 BP	Plan: 1644 Two Story SFR - 1997 UBC	2002
New	Approved Basic #02-100245 BP	Plan: 1644 Two Story SFR - 1997 UBC	2002
New	Approved Basic #01-101344 BP	Plan: 1460 S SFR w/finished lower floor - 1997 UBC	2002
New	Two Story SFR - 1997 UBC		2002
New	Approved Basic #01-104718 BP	Plan: 1760 S/H Split Level SFR - 1997 UBC	2002
New	1550 sf 2-story w/365 sf garage, 27sf covered deck/porch and 80 sf open deck		2002
New	Two Story SFR - 1997 UBC		2002
New	Approved Basic #01-101344 BP	Plan: 1460 S SFR w/finished lower floor - 1997 UBC	2002
New	Split level SFR w/finished basement		2002
New	42 x 64 irreg. 1988 Cambridge/Marlette		2002
New	Approved Basic #98-150985BP	Plan # 5911E Two Story SFR - 1997 UBC	2002
New	Two Story SFR w/unfinished basement - 1997 UBC	Plan: M2535-A3F-2DB	2002
New	2-story w/garage		2002
New	Two-story SFR - 1997 UBC		2002
New	2 Story Duplex w Attached Garages		2002
New	27x66, 1999 Golden West		2002
New	38 x 52 (2002) Fuqua 851		2002
New	Approved Basic #02-100055 BP	Plan 1557 Two Story SFR - 1997 UBC	2002
New	Two-story SFR with attached garage - 1997 UBC		2002
New	Two-story SFR - UBC		2002
New	Two-story SFR - 1997 UBC		2002
New	Approved Basic #00-109207 BP	Plan #2294 A2 F-2 Two Story SFR - 1997 UBC	2002
New	Approved Basic #00-108555 BP	Plan: South Carolina/no den Two Story SFR - 1997 UBC	2002
New	Approved Basic #99-114285 BP	Plan # Aspen 2 Two Story SFR - 1997 UBC	2002
New	Approved Basic #00-109207 BP	Plan #2294 A2 F-2 Two Story SFR - 1997 UBC	2002
New	Approved Basic #00-109209 BP	Plan 2146 Two Story SFR - 1997 UBC	2002
New	Approved Basic #01-112729 BP	Plan No. 2321-Hip Split level SFR w/finished	2002
New	Approved Basic #01-112733 BP	Plan No. 2321-Gable Split level SFR - 1997 U	2002
New	Approved Basic #02- 103268 BP	Plan: North Carolina w/o den (revised) Two Story SFR - 1	2002
New	Approved Basic #01-112730 BP	Plan: 1920 Hip Two Story SFR - 1997 UBC	2002
New	Approved Basic #01-112732 BP	Plan: 1920 Gable Two Story SFR - 1997 UBC	2002
New	Approved Basic #02-102340 BP	Plan: 1943 Hip Rambler Style SFR - 1997 UBC	2002
New	Approved Basic #00-108555 BP	Plan: South Carolina/no den Two Story SFR - 1997 UBC	2002
New	Approved Basic #02- 103268 BP	Plan: North Carolina w/o den (revised) Two Story SFR - 1	2002
New	Approved Basic #00-108555 BP	Plan: South Carolina/no den Two Story SFR - 1997 UBC	2002
New	Approved Basic #01-112732 BP	Plan: 1920 Gable Two Story SFR - 1997 UBC	2002
New	Approved Basic #00-108555 BP	Plan: South Carolina/no den Two Story SFR - 1997 UBC	2002
New	Approved Basic #02-102339 BP	Plan: 1943 Rambler Style SFR - 1997 UBC	2002
New	Approved Basic #01-112736 BP	Plan: 2288 Hip Two Story SFR - 1997 UBC	2002
New	Approved Basic #00-108555 BP	Plan: South Carolina/no den Two Story SFR - 1997 UBC	2002
New	Approved Basic #00-109207 BP	Plan #2294 A2 F-2 Two Story SFR - 1997 UBC	2002
New	Approved Basic #00-109209 BP	Plan 2146 Two Story SFR - 1997 UBC	2002
New	Approved Basic #00-109207 BP	Plan #2294 A2 F-2 Two Story SFR - 1997 UBC	2002
New	Approved Basic #99-114285 BP	Plan # Aspen 2 Two Story SFR - 1997 UBC	2002
New	Approved Basic #01-112735 BP	Plan: 2288 Gable Two Story SFR - 1997 UBC	2002
New	Approved Basic #01-112730 BP	Plan: 1920 Hip Two Story SFR - 1997 UBC	2002

Accessory Dwelling Units

Index # - File Name: 1.0022 - Single Family Dwellings Data\_Snohomish County.pdf

New	Approved Basic #02- 103268 BP	Plan: North Carolina w/o den (revised) Two Story SFR - 1	2002
New	Approved Basic #00-109209 BP	Plan 2146 Two Story SFR - 1997 UBC	2002
New	Approved Basic #99-114285 BP	Plan # Aspen 2 Two Story SFR - 1997 UBC	2002
New	Approved Basic #00-109209 BP	Plan 2146 Two Story SFR - 1997 UBC	2002
New	Approved Basic #00-109207 BP	Plan #2294 A2 F-2 Two Story SFR - 1997 UBC	2002
New	Approved Basic #01-112736 BP	Plan: 2288 Hip Two Story SFR - 1997 UBC	2002
New	Approved Basic #01-112734 BP	Plan: 2164 Hip Two Story SFR - 1997 UBC	2002
New	Approved Basic #00-108555 BP	Plan: South Carolina/no den Two Story SFR - 1997 UBC	2002
New	Approved Basic #01-112731 BP	Plan: 2164 Gable Two Story SFR - 1997 UBC	2002
New	Approved Basic #01-112735 BP	Plan: 2288 Gable Two Story SFR - 1997 UBC	2002
New	Approved Basic #00-108555 BP	Plan: South Carolina/no den Two Story SFR - 1997 UBC	2002
New	Approved Basic #02-102339 BP	Plan: 1943 Rambler Style SFR - 1997 UBC	2002
New	Approved Basic No. 00-107382 BP	Bldrs Plan: 2188 Front 2 Car Two Story style SFR..	2002
New	Approved Basic #02-102339 BP	Plan: 1943 Rambler Style SFR - 1997 UBC	2002
New	Approved Basic #02-102340 BP	Plan: 1943 Hip Rambler Style SFR - 1997 UBC	2002
New	Approved Basic #01-112734 BP	Plan: 2164 Hip Two Story SFR - 1997 UBC	2002
New	Approved Basic #01-112736 BP	Plan: 2288 Hip Two Story SFR - 1997 UBC	2002
New	Approved Basic #01-112729 BP	Plan No. 2321-Hip Split level SFR w/finished	2002
New	Approved Basic #01-112732 BP	Plan: 1920 Gable Two Story SFR - 1997 UBC	2002
New	27x64 2001 Karsten/McKenzie		2002
New	2002 Fleetwood Anniversary 40 x 66		2002
New	Approved Basic #01-106754 BP	Plan: 703 - revised Two Story SFR - 1997 UBC	2002
New	Approved Basic #01-106753 BP	Plan: 702 revised Two Story SFR - 1997 UBC	2002
New	Approved Basic #01-106755 BP	Plan: 704 - revised Two Story SFR - 1997 UBC	2002
New	Approved Basic #01-106756 BP	Plan: 705 - revised Two Story SFR - 1997 UBC	2002
New	Approved Basic #00-110868 BP	Plan: 553 - revised Two Story SFR - 1997 UBC	2002
New	Approved Basic #00-110867 BP	Plan: 552 Two Story SFR - 1997 UBC	2002
New	Approved Basic #01-105843 BP	Plan: 556 R Two style SFR.....1997 UBC	2002
New	Approved Basic #01-105838 BP	Plan: 554 R Two Story SFR.....1997 UBC	2002
New	Approved Basic #01-105842 BP	Plan: 555 R Two Story SFR.....1997 UBC	2002
New	Approved Basic #00-110868 BP	Plan: 553 - revised Two Story SFR - 1997 UBC	2002
New	Approved Basic #02-100273 BP	Plan: 2117 Split Level SFR - 1997 UBC	2002
New	Approved Basic #02-100831 BP	Plan: 1755 Split Level SFR - 1997 UBC	2002
New	Approved Basic #02-100274 BP	Plan: 1710 Two Story SFR - 1997 UBC	2002
New	Approved Basic #02-100273 BP	Plan: 2117 Split Level SFR - 1997 UBC	2002
New	Approved Basic #02-100832 BP	Plan: 1455 Split Level SFR - 1997 UBC	2002
New	Approved Basic #02-100831 BP	Plan: 1755 Split Level SFR - 1997 UBC	2002
New	Approved Basic #02-100273 BP	Plan: 2117 Split Level SFR - 1997 UBC	2002
New	Approved Basic #02-100831 BP	Plan: 1755 Split Level SFR - 1997 UBC	2002
New	Approved Basic #02-100273 BP	Plan: 2117 Split Level SFR - 1997 UBC	2002
New	Approved Basic #02-104469 BP	Plan: 2117 Split Level SFR - 1997 UBC	2002
New	Approved Basic #01-104133 BP	Plan: 1567 crawl Tri-Level SFR - 1997 UBC	2002
New	Approved Basic #02-100273 BP	Plan: 2117 Split Level SFR - 1997 UBC	2002
New	Approved Basic #02-100273 BP	Plan: 2117 Split Level SFR - 1997 UBC	2002
New	Approved Basic #01-111402 BP	Plan: 1680-revised engineering Two-Story style SFR..	2002
New	Approved Basic #02-100832 BP	Plan: 1455 Split Level SFR - 1997 UBC	2002
New	Approved Basic #01-105212 BP	Plan: 1538 Two Story SFR - 1997 UBC	2002

Accessory Dwelling Units

Index # - File Name: 1.0022 - Single Family Dwellings Data\_Snohomish County.pdf

New	Approved Basic #02-100273 BP	Plan: 2117 Split Level SFR - 1997 UBC	2002
New	Approved Basic #02-100274 BP	Plan: 1710 Two Story SFR - 1997 UBC	2002
New	Approved Basic #02-100831 BP	Plan: 1755 Split Level SFR - 1997 UBC	2002
New	Approved Basic #01-111402 BP	Plan: 1680-revised engineering Two-Story style SFR..	2002
New	Approved Basic #02-100273 BP	Plan: 2117 Split Level SFR - 1997 UBC	2002
New	Approved Basic #02-100274 BP	Plan: 1710 Two Story SFR - 1997 UBC	2002
New	Approved Basic #02-100273 BP	Plan: 2117 Split Level SFR - 1997 UBC	2002
New	Approved Basic #02-100274 BP	Plan: 1710 Two Story SFR - 1997 UBC	2002
New	Two-story duplex - 1997 UBC		2002
New	Two-story duplex - 1997 UBC		2002
New	Approved Basic #02-100273 BP	Plan: 2117 Split Level SFR - 1997 UBC	2002
New	Approved Basic #02-100832 BP	Plan: 1455 Split Level SFR - 1997 UBC	2002
New	Approved Basic #02-100273 BP	Plan: 2117 Split Level SFR - 1997 UBC	2002
New	Approved Basic #02-100831 BP	Plan: 1755 Split Level SFR - 1997 UBC	2002
New	Approved Basic #02-100832 BP	Plan: 1455 Split Level SFR - 1997 UBC	2002
New	Approved Basic #02-100273 BP	Plan: 2117 Split Level SFR - 1997 UBC	2002
New	Approved Basic #02-100274 BP	Plan: 1710 Two Story SFR - 1997 UBC	2002
New	Approved Basic #01-104133 BP	Plan: 1567 crawl Tri-Level SFR - 1997 UBC	2002
New	Approved Basic #02-100274 BP	Plan: 1710 Two Story SFR - 1997 UBC	2002
New	Approved Basic #02-100274 BP	Plan: 1710 Two Story SFR - 1997 UBC	2002
New	Approved Basic #01-104133 BP	Plan: 1567 crawl Tri-Level SFR - 1997 UBC	2002
New	Approved Basic #02-100274 BP	Plan: 1710 Two Story SFR - 1997 UBC	2002
New	Approved Basic #02-100832 BP	Plan: 1455 Split Level SFR - 1997 UBC	2002
New	Approved Basic #02-102531 BP	Plan: 1478 Two Story SFR - 1997 UBC	2002
New	Approved Basic #01-111402 BP	Plan: 1680-revised engineering Two-Story style SFR..	2002
New	Approved Basic #02-100274 BP	Plan: 1710 Two Story SFR - 1997 UBC	2002
New	Approved Basic #01-111402 BP	Plan: 1680-revised engineering Two-Story style SFR..	2002
New	Approved Basic #02-100832 BP	Plan: 1455 Split Level SFR - 1997 UBC	2002
New	Approved Basic #02-100273 BP	Plan: 2117 Split Level SFR - 1997 UBC	2002
New	Approved Basic #02-100832 BP	Plan: 1455 Split Level SFR - 1997 UBC	2002
New	Approved Basic #02-100832 BP	Plan: 1455 Split Level SFR - 1997 UBC	2002
New	Approved Basic #02-100273 BP	Plan: 2117 Split Level SFR - 1997 UBC	2002
New	Approved Basic #02-100832 BP	Plan: 1455 Split Level SFR - 1997 UBC	2002
New	Approved Basic #01-111402 BP	Plan: 1680-revised engineering Two-Story style SFR..	2002
New	Approved Basic #02-100832 BP	Plan: 1455 Split Level SFR - 1997 UBC	2002
New	Approved Basic #01-111402 BP	Plan: 1680-revised engineering Two-Story style SFR..	2002
New	Approved Basic #02-100273 BP	Plan: 2117 Split Level SFR - 1997 UBC Opti	2002
New	Approved Basic #02-100274 BP	Plan: 1710 Two Story SFR - 1997 UBC Option	2002
New	Approved Basic #01-105212 BP	Plan: 1538 Two Story SFR - 1997 UBC Option	2002
New	Approved Basic #02-100274 BP	Plan: 1710 Two Story SFR - 1997 UBC Option	2002
New	Approved Basic #01-111402 BP	Plan: 1680-revised engineering Two-Story style SFR..	2002
New	Approved Basic #02-100273 BP	Plan: 2117 Split Level SFR - 1997 UBC Opti	2002
New	Approved Basic #02-100274 BP	Plan: 1710 Two Story SFR - 1997 UBC Option	2002
New	Approved Basic #01-111402 BP	Plan: 1680-revised engineering Two-Story style SFR..	2002
New	Approved Basic #02-100274 BP	Plan: 1710 Two Story SFR - 1997 UBC Option	2002
New	Approved Basic #01-105212 BP	Plan: 1538 Two Story SFR - 1997 UBC (	2002
New	Approved Basic #01-106755 BP	Plan: 704 - revised Two Story SFR - 1997 UBC	2002



Accessory Dwelling Units

Index # - File Name: 1.0022 - Single Family Dwellings Data\_Snohomish County.pdf

New	Approved Basic #01-106756 BP	Plan: 705 - revised Two Story SFR - 1997 UBC	2002
New	Approved Basic #01-106754 BP	Plan: 703 - revised Two Story SFR - 1997 UBC	2002
New	Approved Basic #01-105838 BP	Plan: 554 R Two Story SFR.....1997 UBC	2002
New	Approved Basic #00-110868 BP	Plan: 553 - revised Two Story SFR - 1997 UBC	2002
New	Approved Basic #01-105843 BP	Plan: 556 R Two style SFR.....1997 UBC	2002
New	Approved Basic #00-110867 BP	Plan: 552 Two Story SFR - 1997 UBC	2002
New	Approved Basic #01-105842 BP	Plan: 555 R Two Story SFR.....1997 UBC	2002
New	Approved Basic #01-105843 BP	Plan: 556 R Two style SFR.....1997 UBC	2002
New	Approved Basic #01-105838 BP	Plan: 554 R Two Story SFR.....1997 UBC	2002
New	Approved Basic #00-110868 BP	Plan: 553 - revised Two Story SFR - 1997 UBC	2002
New	Approved Basic #01-105843 BP	Plan: 556 R Two style SFR.....1997 UBC	2002
New	Approved Basic #01-105842 BP	Plan: 555 R Two Story SFR.....1997 UBC	2002
New	Approved Basic #00-110867 BP	Plan: 552 Two Story SFR - 1997 UBC	2002
New	Approved Basic #01-105842 BP	Plan: 555 R Two Story SFR.....1997 UBC	2002
New	Approved Basic #01-105838 BP	Plan: 554 R Two Story SFR.....1997 UBC	2002
New	Approved Basic #00-110868 BP	Plan: 553 - revised Two Story SFR - 1997 UBC	2002
New	Approved Basic #01-105842 BP	Plan: 555 R Two Story SFR.....1997 UBC	2002
New	Approved Basic #01-105838 BP	Plan: 554 R Two Story SFR.....1997 UBC	2002
New	Approved Basic #01-105843 BP	Plan: 556 R Two style SFR.....1997 UBC	2002
New	Approved Basic #00-110868 BP	Plan: 553 - revised Two Story SFR - 1997 UBC	2002
New	Approved Basic #00-110867 BP	Plan: 552 Two Story SFR - 1997 UBC	2002
New	Approved Basic #01-105842 BP	Plan: 555 R Two Story SFR.....1997 UBC	2002
New	Approved Basic #00-110868 BP	Plan: 553 - revised Two Story SFR - 1997 UBC	2002
New	Approved Basic #01-105838 BP	Plan: 554 R Two Story SFR.....1997 UBC	2002
New	Approved Basic #01-105843 BP	Plan: 556 R Two style SFR.....1997 UBC	2002
New	Approved Basic #01-105842 BP	Plan: 555 R Two Story SFR.....1997 UBC	2002
New	Approved Basic #00-110867 BP	Plan: 552 Two Story SFR - 1997 UBC	2002
New	Approved Basic #01-106753 BP	Plan: 702 revised Two Story SFR - 1997 UBC	2002
New	Approved Basic #01-106757 BP	Plan: 706 - revised Two Story SFR - 1997 UBC	2002
New	Approved Basic #01-106754 BP	Plan: 703 - revised Two Story SFR - 1997 UBC	2002
New	Approved Basic #01-106756 BP	Plan: 705 - revised Two Story SFR - 1997 UBC	2002
New	Approved Basic #01-106757 BP	Plan: 706 - revised Two Story SFR - 1997 UBC	2002
New	Approved Basic #01-106755 BP	Plan: 704 - revised Two Story SFR - 1997 UBC	2002
New	2 Story w/ 3 Car		2002
New	Two-story duplex - 1997 UBC		2002
New	Approved Basic #02-100274 BP	Plan: 1710 Two Story SFR - 1997 UBC Option	2002
New	Approved Basic #02-100273 BP	Plan: 2117 Split Level SFR - 1997 UBC Op	2002
New	Approved Basic #02-100274 BP	Plan: 1710 Two Story SFR - 1997 UBC Option: S	2002
New	Approved Basic #01-105212 BP	Plan: 1538 Two Story SFR - 1997 UBC	2002
New	Approved Basic #01-111402 BP	Plan: 1680-revised engineering Two-Story style SFR..	2002
New	2 story SFR w/finished basement and attached 2 car garage		2002
New	Approved Basic #01-105212 BP	Plan: 1538 Two Story SFR - 1997 UBC	2002
New	Approved Basic #01-111402 BP	Plan: 1680-revised engineering Two-Story style SFR..	2002
New	Approved Basic #01-105212 BP	Plan: 1538 Two Story SFR - 1997 UBC	2002
New	Approved Basic #02-100832 BP	Plan: 1455 Split Level SFR - 1997 UBC	2002
New	Approved Basic #02-102531 BP	Plan: 1478 Two Story SFR - 1997 UBC	2002
New	Approved Basic #02-102531 BP	Plan: 1478 Two Story SFR - 1997 UBC	2002

Accessory Dwelling Units

Index # - File Name: 1.0022 - Single Family Dwellings Data\_Snohomish County.pdf

New	Approved Basic #02-100832 BP	Plan: 1455 Split Level SFR - 1997 UBC	2002
New	Approved Basic #02-100832 BP	Plan: 1455 Split Level SFR - 1997 UBC	2002
New	Approved Basic #02-109386 BP	Plan: 1710 Basement Two Story w/finished baseme	2002
New	Approved Basic #02-109386 BP	Plan: 1710 Basement Two Story SFR w/finished baser	2002
New	Approved Basic #02-100832 BP	Plan: 1455 Split Level SFR - 1997 UBC	2002
New	Approved Basic #02-100273 BP	Plan: 2117 Split Level SFR - 1997 UBC Opti	2002
New	Approved Basic #02-100273 BP	Plan: 2117 Split Level SFR - 1997 UBC	2002
New	Approved Basic #01-111402 BP	Plan: 1680-revised engineering Two-Story style SFR..	2002
New	Approved Basic #01-105212 BP	Plan: 1538 Two Story SFR - 1997 UBC	2002
New	Approved Basic #01-105212 BP	Plan: 1538 Two Story SFR - 1997 UBC	2002
New	Approved Basic #01-105212 BP	Plan: 1538 Two Story SFR - 1997 UBC	2002
New	Approved Basic #02-100273 BP	Plan: 2117 Split Level SFR - 1997 UBC	2002
New	Approved Basic 02-102507BP	Plan M2980A4FT-0 Two-story SFR - 1997 UBC	2002
New	Approved Basic #01-105631 BP	Plan: 3219 Two Story Style SFR....1997 UBC	2002
New	Approved Basic #02-103093 BP	Plan: San Juan Two Story SFR - 1997 UBC	2002
New	Approved Basic #02-103091BP	Plan: Whidbey/side entry Two Story SFR - 1997 U	2002
New	2-story w/garage and covered porch		2002
New	Approved Basic #02-103093 BP	Plan: San Juan Two Story SFR - 1997 UBC	2002
New	Approved Basic #02-103091BP	Plan: Whidbey/side entry Two Story SFR - 1997 U	2002
New	Approved Basic #02-103096 BP	Plan: Mini-Whidbey Two Story SFR - 1997 UBC	2002
New	Approved Basic #02-103093 BP	Plan: San Juan Two Story SFR - 1997 UBC	2002
New	2 Story w/ 3 Car		2002
New	Approved Basic #01-101434 BP	Plan: 2042 Two Story SFR -1 997 UBC	2002
New	Approved Basic #01-101439 BP	Plan: 2409 A Two Story SFR - 1997 UBC	2002
New	Approved Basic #01-101438 BP	Plan: 2409 C Two Story SFR - 1997 UBC	2002
New	Two Story SFR - 1997 UBC	Plan: 1434	2002
New	Two Story SFR - 1997 UBC	Plan: 1362	2002
New	Two Story SFR - 1997 UBC	Plan: Sterling	2002
New	Two Story SFR - 1997 UBC	Plan: 1434	2002
New	Two Story SFR - 1997 UBC	Plan: 1362	2002
New	Two Story SFR - 1997 UBC	Plan: 1434	2002
New	Two Story SFR - 1997 UBC	Plan: 1362	2002
New	Two Story SFR - 1997 UBC	Plan: 1434	2002
New	Two Story SFR - 1997 UBC	Plan: 1362	2002
New	Two Story SFR with Attached Garage	1997 UBC	2002
New	Two Story SFR - 1997 UBC	Plan: 1362	2002
New	Approved Basic #02-100055 BP	Plan: 1615 Two Story SFR -1997 UBC	2002
New	Approved Basic #02-100055 BP	Plan: 1615 Two Story SFR -1997 UBC	2002
New	SFR w/finished lower floor - 1997 UBC		2002
New	SFR with 559 SQ FT Finished Basement and Attached Garage		2002
New	Approved Basic #02-105418BP	Plan: 1728 Split Entry SFR - 1997 UBC	2002
New	Approved Basic #02-100055 BP	Plan: 1615 Two Story SFR -1997 UBC	2002
New	Approved Basic #02-100055 BP	Plan: 1615 Two Story SFR -1997 UBC	2002
New	Approved Basic #02-105418BP	Plan: 1728 Split Entry SFR - 1997 UBC	2002
New	26x66 (2002) Oakwood/Marlette		2002
New	2 Story SFR w/ 3 Car		2002
New	Split level SFR		2002

Accessory Dwelling Units

Index # - File Name: 1.0022 - Single Family Dwellings Data\_Snohomish County.pdf

New	Approved Basic #01-105185 BP	Plan: 2415 Two Story SFR - 1997 UBC	2002
New	Two Story SFR - 1997 UBC	Plan: 2793	2002
New	Rambler Style SFR - 1997 UBC	Plan: 2370	2002
New	Approved Basic #01-105185 BP	Plan: 2415 Two Story SFR - 1997 UBC	2002
New	2-Story SFR w/attached garage		2002
New	Approved Basic #01-105185 BP	Plan: 2415 Two Story SFR - 1997 UBC	2002
New	Approved Basic #00-101627 BP	Plan: 1221 A Two Story SFR - 1997 UBC	2002
New	Approved Basic #00-101627 BP	Plan: 1221 A Two Story SFR - 1997 UBC	2002
New	Approved Basic #00-101627 BP	Plan: 1221 A Two Story SFR - 1997 UBC	2002
New	Approved Basic #00-101627 BP	Plan: 1221 A Two Story SFR - 1997 UBC	2002
New	668-sq. ft. SFR w/attached 487-sq. ft. garage, (2-nd story to be moved onto site from nearby)		2002
New	Approved Basic #02-101122 BP	Plan: Cottonwood Split Level Duplex w/finished lc	2002
New	Approved Basic #02-101129 BP	Plan: Aspen Duplex Gable Two Story Duplex - 1997	2002
New	Approved Basic #02-101140 BP	Plan: Tamarack Two Story Duplex - 1997 UBC	2002
New	Approved Basic #02-101140 BP	Plan: Tamarack Two Story Duplex - 1997 UBC	2002
New	Approved Basic #02-101129 BP	Plan: Aspen Duplex Gable Two Story Duplex - 1997	2002
New	Approved Basic #02-101122 BP	Plan: Cottonwood Split Level Duplex w/finished lc	2002
New	Approved Basic #02-101140 BP	Plan: Tamarack Two Story Duplex - 1997 UBC	2002
New	Approved Basic #02-101129 BP	Plan: Aspen Duplex Gable Two Story Duplex - 1997	2002
New	Approved Basic #02-101140 BP	Plan: Tamarack Two Story Duplex - 1997 UBC	2002
New	Approved Basic #02-101129 BP	Plan: Aspen Duplex Gable Two Story Duplex - 1997	2002
New	Approved Basic #02-101122 BP	Plan: Cottonwood Split Level Duplex w/finished lc	2002
New	Approved Basic #02-101122 BP	Plan: Cottonwood Split Level Duplex w/finished lc	2002
New	Approved Basic #02-101129 BP	Plan: Aspen Duplex Gable Two Story Duplex - 1997	2002
New	Approved Basic #02-101122 BP	Plan: Cottonwood Split Level Duplex w/finished lc	2002
New	Approved Basic #02-101129 BP	Plan: Aspen Duplex Gable Two Story Duplex - 1997	2002
New	Approved Basic #02-101140 BP	Plan: Tamarack Two Story Duplex - 1997 UBC	2002
New	Approved Basic #02-101129 BP	Plan: Aspen Duplex Gable Two Story Duplex - 1997	2002
New	Approved Basic #02-101140 BP	Plan: Tamarack Two Story Duplex - 1997 UBC	2002
New	Approved Basic #02-101129 BP	Plan: Aspen Duplex Gable Two Story Duplex - 1997	2002
New	Approved Basic #02-101140 BP	Plan: Tamarack Two Story Duplex - 1997 UBC	2002
New	Approved Basic #02-101140 BP	Plan: Tamarack Two Story Duplex - 1997 UBC	2002
New	2-story w/attached garage & covered deck/porch		2002
New	2 story SFR with breezeway & garage		2002
New	Two-story SFR w/attached garage		2002
New	Rambler Style SFR - 1997 UBC		2002
New	28x71 2002 Palm Harbor		2002
New	Rambler with Attached Garage		2002
New	Approved Basic #02-109782 BP	Plan 1722 Rambler Style SFR - 1997 UBC	2002
New	Approved Basic #02-109015 BP	Plan: 1813 Rambler Style SFR - 1997 UBC	2002
New	Approved Basic #02-109015 BP	Plan: 1813 Rambler Style SFR - 1997 UBC	2002
New	Approved Basic #02-109610 BP	Plan: 2094 Rambler Style SFR - 1997 UBC	2002
New	Two-story SFR w/attached garage		2002
New	Rambler style SFR w/attached garage.		2002
New	rambler w/ garage, covered deck/porch and patio		2002
New	Rambler styles SFR w/attached garage.		2002
New	Rambler w/ garage and covered deck/porch & patio		2002

Accessory Dwelling Units

Index # - File Name: 1.0022 - Single Family Dwellings Data\_Snohomish County.pdf

New	2-story SFR w/attached garage.		2002
New	2-Story SFR w/attached garage.		2002
New	Rambler Style SFR - 1997 UBC		2002
New	2 Story Duplex w/ Attached Garages		2002
New	Approved Basic #02-103093 BP	Plan: San Juan Two Story SFR - 1997 UBC	2002
New	Two-story SFR w/attached garage		2002
New	Two-story SFR w/attached garage	Builders Plan: San Juan	2002
New	Approved Basic #02-103091BP	Plan: Whidbey/side entry Two Story SFR - 1997	2002
New	Approved Basic #02-103096 BP	Plan: Mini-Whidbey Two Story SFR - 1997 UBC	2002
New	One-story SFR		2002
New	Approved Basic #02-102103-BP	Plan: 1014 - Rambler Rambler Style SFR - 1997 UBC	2002
New	Approved Basic #00-101627 BP	Plan: 1221 A Two Story SFR - 1997 UBC	2002
New	Approved Basic #02-102103-BP	Plan: 1014 - Rambler Rambler Style SFR - 1997 UBC	2002
New	Approved Basic #02-105624 BP	Bldrs Plan No. 1015 Rambler Style SFR...1997 UI	2002
New	Approved Basic #00-104229 BP	Plan: 1533 revised Two Story SFR - 1997 UE	2002
New	Approved Basic #00-101627 BP	Plan: 1221 A Two Story SFR - 1997 UBC	2002
New	Approved Basic #00-104229 BP	Plan: 1533 revised Two Story SFR - 1997 UE	2002
New	Approved Basic #00-104229 BP	Plan: 1533 revised Two Story SFR - 1997 UE	2002
New	Approved Basic #00-104229 BP	Plan: 1533 revised Two Story SFR - 1997 UE	2002
New	Approved Basic #00-101627 BP	Plan: 1221 A Two Story SFR - 1997 UBC	2002
New	Approved Basic #01-101769 BP	Plan: 1290 Two Story SFR - 1997 UBC	2002
New	Approved Basic #00-101627 BP	Plan: 1221 A Two Story SFR - 1997 UBC	2002
New	Approved Basic #01-101769 BP	Plan: 1290 Two Story SFR - 1997 UBC	2002
New	Approved Basic #02-105624 BP	Plan: 1015 Rambler Style SFR - 1997 UBC	2002
New	One-story SFR	Builders Plan: 1015	2002
New	Approved Basic #00-101627 BP	Plan: 1221 A Two Story SFR - 1997 UBC	2002
New	Approved Basic #01-101769 BP	Plan: 1290 Two Story SFR - 1997 UBC	2002
New	Approved Basic #00-101627 BP	Plan: 1221 A Two Story SFR - 1997 UBC	2002
New	Approved Basic #01-101769 BP	Plan: 1290 Two Story SFR - 1997 UBC	2002
New	Approved Basic #02-102103-BP	Plan: 1014 - Rambler Rambler Style SFR - 1997 UBC	2002
New	Approved Basic #02-102103-BP	Plan: 1014 - Rambler Rambler Style SFR - 1997 UBC	2002
New	Approved Basic #00-101627 BP	Plan: 1221 A Two Story SFR - 1997 UBC	2002
New	Approved Basic #01-101769 BP	Plan: 1290 Two Story SFR - 1997 UBC	2002
New	Approved Basic #01-101769 BP	Plan: 1290 Two Story SFR - 1997 UBC	2002
New	Approved Basic #00-101627 BP	Plan: 1221 A Two Story SFR - 1997 UBC	2002
New	Approved Basic #00-101627 BP	Plan: 1221 A Two Story SFR - 1997 UBC	2002
New	Approved Basic #00-101627 BP	Plan: 1221 A Two Story SFR - 1997 UBC	2002
New	Approved Basic #00-101627 BP	Plan: 1221 A Two Story SFR - 1997 UBC	2002
New	Approved Basic #01-101769 BP	Plan: 1290 Two Story SFR - 1997 UBC	2002
New	Approved Basic #01-101769 BP	Plan: 1290 Two Story SFR - 1997 UBC	2002
New	Approved Basic #01-101769 BP	Plan: 1290 Two Story SFR - 1997 UBC	2002
New	Approved Basic #01-101769 BP	Plan: 1290 Two Story SFR - 1997 UBC	2002
New	Approved Basic #00-104229 BP	Plan: 1533 revised Two Story SFR - 1997 UE	2002
New	Approved Basic #02-105624 BP	Bldrs Plan No. 1015 Rambler Style SFR...1997 UI	2002
New	Approved Basic #02-105624 BP	Bldrs Plan No. 1015 Rambler Style SFR...1997 UI	2002
New	Approved Basic #02-105624 BP	Bldrs Plan No. 1015 Rambler Style SFR...1997 UI	2002
New	Approved Basic #00-101627 BP	Plan: 1221 A Two Story SFR - 1997 UBC	2002

Accessory Dwelling Units

Index # - File Name: 1.0022 - Single Family Dwellings Data\_Snohomish County.pdf

New	Approved Basic #01-101769 BP	Plan: 1290 Two Story SFR - 1997 UBC	2002
New	Approved Basic #00-104229 BP	Plan: 1533 revised Two Story SFR - 1997 UE	2002
New	Approved Basic #00-104229 BP	Plan: 1533 revised Two Story SFR - 1997 UE	2002
New	Approved Basic #00-104538 BP	Plan: 1478 SFR w/semi-finished basement - 1997 UE	2002
New	Approved Basic #02-107384 BP	Plan 2193 Split level SFR - 1997 UBC	2002
New	Approved Basic #00-101627 BP	Plan: 1221 A Two Story SFR - 1997 UBC	2002
New	Approved Basic #01-101769 BP	Plan: 1290 Two Story SFR - 1997 UBC	2002
New	Approved Basic #01-101769 BP	Plan: 1290 Two Story SFR - 1997 UBC	2002
New	Approved Basic #00-101627 BP	Plan: 1221 A Two Story SFR - 1997 UBC	2002
New	Approved Basic #00-101627 BP	Plan: 1221 A Two Story SFR - 1997 UBC	2002
New	Approved Basic #01-101769 BP	Plan: 1290 Two Story SFR - 1997 UBC	2002
New	Approved Basic #01-101769 BP	Plan: 1290 Two Story SFR - 1997 UBC	2002
New	Approved Basic #01-101769 BP	Plan: 1290 Two Story SFR - 1997 UBC	2002
New	Approved Basic #00-101627 BP	Plan: 1221 A Two Story SFR - 1997 UBC	2002
New	Approved Basic #00-101627 BP	Plan: 1221 A Two Story SFR - 1997 UBC	2002
New	Approved Basic #01-101769 BP	Plan: 1290 Two Story SFR - 1997 UBC	2002
New	Approved Basic #01-101769 BP	Plan: 1290 Two Story SFR - 1997 UBC	2002
New	Approved Basic #00-101627 BP	Plan: 1221 A Two Story SFR - 1997 UBC	2002
New	Approved Basic #00-101627 BP	Plan: 1221 A Two Story SFR - 1997 UBC	2002
New	Approved Basic #01-101769 BP	Plan: 1290 Two Story SFR - 1997 UBC	2002
New	Approved Basic #02-105624 BP	Bldrs Plan No. 1015 Rambler Style SFR...1997 UI	2002
New	Approved Basic #02-107381 BP	Plan 1956 Split 1160 sf SFR w/semi-finished	2002
New	Approved Basic #02-107384 BP	Plan 2193 Split level SFR - 1997 UBC	2002
New	SFR w/semi-finished lower floor - 1997 UBC	Plan: 1700	2002
New	Approved Basic #02-107384 BP	Plan 2193 Split level SFR - 1997 UBC	2002
New	Approved Basic #02-107384 BP	Plan 2193 Split level SFR - 1997 UBC	2002
New	Approved Basic #02-107380 BP	Plan 1771 Cal 1158 sf SFR w/semi-finished bas	2002
New	Approved Basic #00-104550 BP	Plan: 1220 SFR w/semi-finished basement - 1997 U	2002
New	Approved Basic #00-104538 BP	Plan: 1478 SFR w/semi-finished basement - 1997 UE	2002
New	Approved Basic #00-104550 BP	Plan: 1220 SFR w/semi-finished basement - 1997 U	2002
New	Approved Basic #00-104538 BP	Plan: 1478 SFR w/semi-finished basement - 1997 UE	2002
New	Approved Basic #00-104550 BP	Plan: 1220 SFR w/semi-finished basement - 1997 U	2002
New	Approved Basic #02-105909 BP	Plan: 1484 - revised Two Story SFR - 1997 UBC	2002
New	Approved Basic #02-105909 BP	Plan: 1484 - revised Two Story SFR - 1997 UBC	2002
New	Approved Basic #00-104550 BP	Plan: 1220 SFR w/semi-finished basement - 1997 U	2002
New	Approved Basic #00-104550 BP	Plan: 1220 SFR w/semi-finished basement - 1997 U	2002
New	Approved Basic #00-104538 BP	Plan: 1478 SFR w/semi-finished basement - 1997 UE	2002
New	Approved Basic #00-104538 BP	Plan: 1478 SFR w/semi-finished basement - 1997 UE	2002
New	Approved Basic #02-105909 BP	Plan: 1484- revised Two Story SFR - 1997 UBC	2002
New	Approved Basic #99-102547BP	Plan: 1484 Two Story SFR - 1997 UBC	2002
New	Approved Basic #00-104550 BP	Plan: 1220 SFR w/semi-finished basement - 1997 U	2002
New	Approved Basic #00-104550 BP	Plan: 1220 SFR w/semi-finished basement - 1997 U	2002
New	Approved Basic #00-104538 BP	Plan: 1478 SFR w/semi-finished basement - 1997 UE	2002
New	Approved Basic #00-104538 BP	Plan: 1478 SFR w/semi-finished basement - 1997 UBC	2002
New	Approved Basic #99-102547BP	Plan: 1484 Two Story SFR - 1997 UBC	2002
New	Approved Basic #00-104550 BP	Plan: 1220 SFR w/semi-finished basement - 1997 U	2002
New	Approved Basic #00-104538 BP	Plan: 1478 SFR w/semi-finished basement - 1997 UE	2002

Accessory Dwelling Units

Index # - File Name: 1.0022 - Single Family Dwellings Data\_Snohomish County.pdf

New	Approved Basic #00-104550 BP	Plan: 1220 SFR w/semi-finished basement - 1997 L	2002
New	Approved Basic #99-102547 BP	Plan: 1484 Two Story SFR - 1997 UBC	2002
New	Approved Basic #99-102547BP	Plan: 1484 Two Story SFR - 1997 UBC	2002
New	Approved Basic #00-104538 BP	Plan: 1478 SFR w/semi-finished basement - 1997 Uf	2002
New	Approved Basic #00-104538 BP	Plan: 1478 SFR w/semi-finished basement - 1997 Uf	2002
New	Approved Basic #00-104550 BP	Plan: 1220 SFR w/semi-finished basement - 1997 L	2002
New	Approved Basic #00-104538 BP	Plan: 1478 SFR w/semi-finished basement - 1997 Uf	2002
New	Approved Basic #00-104550 BP	Plan: 1220 SFR w/semi-finished basement - 1997 L	2002
New	Approved Basic #00-104538 BP	Plan: 1478 SFR w/semi-finished basement - 1997 Uf	2002
New	Approved Basic #00-104550 BP	Plan: 1220 SFR w/semi-finished basement - 1997 L	2002
New	Approved Basic #00-104538 BP	Plan: 1478 SFR w/semi-finished basement - 1997 Uf	2002
New	Approved Basic #02-108403 BP	Plan: 1220 SFR w/semi-finished basement - 1997 L	2002
New	Approved Basic #00-104306 BP	Plan: 1998 crawl SFR w/finished basement - 1	2002
New	2-story style SFR.....1997 UBC		2002
New	Two Story SFR - 1997 UBC	Plan: 1905	2002
New	Two Story SFR - 1997 UBC	Plan: M 1927 A-2F-0	2002
New	Approved Basic #01-111225 BP	Plan: #2098 Mid-entry style SFR...1997 UBC	2002
New	Approved Basic #02- 108966 BP	Plan #1837 A Two Story SFR - 1997 UBC	2002
New	Approved Basic #02-106470 BP	Plan: 1905 Two Story SFR - 1997 UBC	2002
New	Approved Basic #02-107090 BP	Plan: 2294 Two Story SFR - 1997 UBC	2002
New	Approved Basic #02-107090 BP	Plan: 2294 Two Story SFR - 1997 UBC	2002
New	Approved Basic #00-104306 BP	Plan: 1998 crawl SFR w/finished basement - 1	2002
New	Approved Basic #02-106468 BP	Plan: 1927 Two Story SFR - 1997 UBC	2002
New	Approved Basic #02-106470 BP	Plan: 1905 Two Story SFR - 1997 UBC	2002
New	Approved Basic #00-104306 BP	Plan: 1998 crawl SFR w/finished basement - 1	2002
New	Approved Basic #02-107090 BP	Plan: 2294 Two Story SFR - 1997 UBC	2002
New	Approved Basic #02-106468 BP	Plan: 1927 Two Story SFR - 1997 UBC	2002
New	Approved Basic #02-106470 BP	Plan: 1905 Two Story SFR - 1997 UBC	2002
New	2347 sf 2-story w/128 sf finished basement and 685 sf garage and 88 sf covered porch		2002
New	Approved Basic #02-108402 BP	Plan: 1478 SFR w/finished basement - 1997 UBC	2002
New	Approved Basic #02-108403 BP	Plan: 1220 SFR w/semi-finished basement - 1997 L	2002
New	Approved Basic #02-108403 BP	Plan: 1220 SFR w/semi-finished basement - 1997 L	2002
New	Approved Basic #02-108402 BP	Plan: 1478 SFR w/finished basement - 1997 UBC	2002
New	Approved Basic #02-108403 BP	Plan: 1220 SFR w/semi-finished basement - 1997 L	2002
New	Approved Basic #02-108402 BP	Plan: 1478 SFR w/finished basement - 1997 UBC	2002
New	Approved Basic #02-105813 BP	Plan: 2625 Two Story SFR - 1997 UBC	2002
New	1992 Redman 44 x 14		2002
New	Two story Duplex with attached single car garages.		2002
New	Two Story SFR with Attached Garage & Unfin Basement		2002
New	Approved Basic #02-103334 BP	Plan: Rainier/4 SFR w/finished lower floor - 19!	2002
New	Approved Basic #02-103348 BP	Plan: 1528/Gable Two Story SFR.....1997 UBC	2002
New	Approved Basic #02-101814 BP	Plan: Olympic/Gable (B) Two Story SFR - 1997 UBC	2002
New	Approved Basic #02-100866 BP	Plan: Whitney - Hip Two Story SFR - 1997 UBC	2002
New	Approved Basic #02-102329 BP	Plan: Stewart/Gable (B) SFR w/finished lower floor	2002
New	Approved Basic #02-101809 BP	Plan: Adams/Gable (B) Two Story SFR - 1997 UB(	2002
New	Approved Basic #02-103330 BP	Plan: Whitney/Gable Two Story SFR - 1997 UBC	2002
New	Approved Basic #02-103339 BP	Plan: Baker/Gable B SFR w/finished basement - 1997	2002

Accessory Dwelling Units

Index # - File Name: 1.0022 - Single Family Dwellings Data\_Snohomish County.pdf

New	Approved Basic #02-101814 BP	Plan: Olympic/Gable - B	Two Story SFR - 1997 UBC	2002
New	Approved Basic #02-101809 BP	Plan: Adams/Gable (B)	Two Story SFR - 1997 UBC	2002
New	Approved Basic #02-109693 BP	Plan: Whitney - Hip (D)	Two Story SFR - 1997 UBC	2002
New	Approved Basic #02-109684 BP	Plan: Jasper/Gable (A)	Two Story SFR - 1997 UBC	2002
New	Two Story SFR - 1997 UBC	Plan: Glacier/Gable		2002
New	Approved Basic #02-109683 BP	Plan: Shasta/Gable (C)	Two Story SFR - 1997 UBC	2002
New	Approved Basic #02-109683 BP	Plan: Shasta/Gable (C)	Two Story SFR - 1997 UBC	2002
New	Approved Basic #02-106229 BP	Plan: Whitney/Gable (B)	Two Story SFR - 1997 UBC	2002
New	Approved Basic #02-106229 BP	Plan: Whitney/Gable (B)	Two Story SFR - 1997 UBC	2002
New	Approved Basic #02-106229 BP	Plan: Whitney/Gable (B)	Two Story SFR - 1997 UBC	2002
New	Approved Basic #02-106231 BP	Plan: Stewart/Gable (C)	SFR w/finished lower floor	2002
New	Rambler Style SFR - 1997 UBC	Plan: Freemont/Gable		2002
New	Approved Basic #02-106233 BP	Plan: Shasta/Gable (B)	Two Story SFR - 1997 UBC	2002
New	Approved Basic #02-106236 BP	Plan: Olympic/Gable (C)	Two Story SFR - 1997 UBC	2002
New	Approved Basic #02-102796 BP	Plan: Trinity/Gable (B)	Two Story SFR - 1997 UBC	2002
New	Approved Basic #02-101814 BP	Plan: Olympic/Gable (B)	Two Story SFR - 1997 UBC	2002
New	Approved Basic #02-103330 BP	Plan: Whitney/Gable	Two Story SFR - 1997 UBC	2002
New	Tri-Level SFR - 1997 UBC	Plan: Pilchuck/Gable		2002
New	Approved Basic #02-100295 BP	Plan: Shasta/Gable	Two Story SFR - 1997 UBC	2002
New	Approved Basic #02-106228 BP	Plan: Whitney - Hip (C)	Two Story SFR - 1997 UBC	2002
New	Approved Basic #02-106236 BP	Plan: Olympic/Gable (C)	Two Story SFR - 1997 UBC	2002
New	Approved Basic #02-106233 BP	Plan: Shasta/Gable (B)	Two Story SFR - 1997 UBC	2002
New	Two Story SFR - 1997 UBC	Plan: Jasper/Gable		2002
New	Approved Basic #02-106233 BP	Plan: Shasta/Gable (B)	Two Story SFR - 1997 UBC	2002
New	Approved Basic #02-106228 BP	Plan: Whitney - Hip (C)	Two Story SFR - 1997 UBC	2002
New	Approved Basic #02-106228 BP	Plan: Whitney - Hip (C)	Two Story SFR - 1997 UBC	2002
New	Approved Basic #02-103348 BP	Plan: 1528/Gable	Two Story SFR.....1997 UBC	2002
New	Approved Basic #02-102796 BP	Plan: Trinity/Gable (B)	Two Story SFR - 1997 UBC	2002
New	Approved Basic #02-103330 BP	Plan: Whitney/Gable	Two Story SFR - 1997 UBC	2002
New	Approved Basic #02-102329 BP	Plan: Stewart/Gable (B)	SFR w/finished lower floor	2002
New	Approved Basic #02-102796 BP	Plan: Trinity/Gable (B)	Two Story SFR - 1997 UBC	2002
New	Approved Basic #02-103348 BP	Plan: 1528/Gable	Two Story SFR.....1997 UBC	2002
New	Rambler style SFR w/attached garage.			2002
New	Approved Basic #99-113971 BP	Plan: 1315	Split Level SFR - 1997 UBC	2002
New	1202sf Rambler style SFR - 1997 UBC			2002
New	Rambler style SFR w/attached garage			2002
New	Rambler style SFR w/attached garage			2002
New	Rambler style SFR w/attached garage			2002
New	Rambler w/ 1 Car			2002
New	1215sf Rambler-style SFR - 1997 UBC			2002
New	1200sf Rambler style SFR - 1997 UBC			2002
New	1202sf Rambler style SFR - 1997 UBC			2002
New	Rambler style SFR w/attached garage			2002
New	1202sf Rambler style SFR - 1997 UBC			2002
New	Rambler style SFR w/attached garage			2002
New	Rambler style SFR w/attached garage			2002
New	Rambler style SFR w/attached garage			2002

Accessory Dwelling Units

Index # - File Name: 1.0022 - Single Family Dwellings Data\_Snohomish County.pdf

New	Rambler style SFR w/attached garage		2002
New	Rambler style SFR w/attached garage		2002
New	Rambler style SFR w/attached garage		2002
New	1200sf rambler style SFR - 1997 UBC		2002
New	Rambler style SFR - 1997 UBC		2002
New	1202 sf rambler w/359 sf garage		2002
New	Rambler style SFR - 1997UBC		2002
New	1200 sf rambler w/358 sf garage		2002
New	Rambler w/ 1 Car		2002
New	Rambler w/ 1 Car		2002
New	Rambler w/ 1 Car		2002
New	2-story w/ attached garage		2002
New	Approved Basic #02-107441 BP	Plan 1130 One-story Duplex - 1997 UBC	2002
New	Approved Basic #02-107441 BP	Plan 1130 One-story Duplex - 1997 UBC	2002
New	Approved Basic #02-107441 BP	Plan 1130 One-story Duplex - 1997 UBC	2002
New	Approved Basic #02-107441 BP	Plan 1130 One-story Duplex - 1997 UBC	2002
New	2 story SFR with attached garge		2002
New	2 story SFR with attached garage		2002
New	Approved Basic #02-106236 BP	Plan: Olympic/Gable (C) Two Story SFR - 1997 UB	2002
New	Approved Basic #02-103339 BP	Plan: Baker/Gable B SFR w/finished basement - :	2002
New	Approved Basic #02-101814 BP	Plan: Olympic/Gable (B) Two Story SFR - 1997 UBC	2002
New	Approved Basic #02-101812 BP	Plan: Whitney - Hip (B) Two Story SFR - 1997 UBC	2002
New	Rambler style SFR with attached garage		2002
New	One-story SFR		2002
New	Rambler style SFR with attached garage		2002
New	One-story SFR		2002
New	Rambler style SFR with attached garage		2002
New	Approved Basic #99-113971 BP	Plan: 1315 Split Level SFR - 1997 UBC	2002
New	Approved Basic #02-104896 BP	Plan 2274 Rambler Style SFR - 1997 UBC	2002
New	Approved Basic 99-112317-BP	Bldrs. Plan #1647 Two Story SFR 1997-UBC	2002
New	Approved Basic #98-110231BP	Plan: Rutledge 1365 One-story SFR w/finisl	2002
New	2 story SFR with attached garage		2002
New	Approved Basic #02-104617 BP	Plan: 110989 Two Story SFR - 1997 UBC	2002
New	Approved Basic #02-104622 BP	Plan: 110487 Two Story SFR - 1997 UBC	2002
New	Approved Basic 99-112322-BP	Plan: #1554. Two Story SFR 1997-UBC	2002
New	Approved Basic #02-105518 BP	Plan: 1550 Two Story SFR - 1997 UBC	2002
New	Approved Basic #02-105518 BP	Plan: 1550 Two Story SFR - 1997 UBC	2002
New	Two Story SFR - 1997 UBC	Plan: 1550	2002
New	Two Story SFR - 1997 UBC	Plan: 1540	2002
New	Approved Basic #98-110231BP	Plan: Rutledge 1365 One-story SFR w/finisl	2002
New	Approved Basic #98-110231BP	Plan: Rutledge 1365 One-story SFR w/finisl	2002
New	Approved Basic #02-105518 BP	Plan: 1550 Two Story SFR - 1997 UBC	2002
New	Approved Basic #02-105518 BP	Plan: 1550 Two Story SFR - 1997 UBC	2002
New	Approved Basic #02-105518 BP	Plan: 1550 Two Story SFR - 1997 UBC	2002
New	2 Story SFR with attached garage		2002
New	Approved Basic #02-104617 BP	Plan: 110989 Two Story SFR - 1997 UBC	2002
New	Approved Basic #02-105518 BP	Plan: 1550 Two Story SFR - 1997 UBC	2002



Accessory Dwelling Units

Index # - File Name: 1.0022 - Single Family Dwellings Data\_Snohomish County.pdf

New	Approved Basic #02-105518 BP	Plan: 1550 Two Story SFR - 1997 UBC	2002
New	Approved Basic #02-104622 BP	Plan: 110487 Two Story SFR - 1997 UBC	2002
New	Approved Basic #02-104632 BP	Plan: 110293 Two Story SFR - 1997 UBC	2002
New	Approved Basic #02-104617 BP	Plan: 110989 Two Story SFR - 1997 UBC	2002
New	2 Story SFR with attached garage		2002
New	Approved Basic #02-104632 BP	Plan: 110293 Two Story SFR - 1997 UBC	2002
New	2 Story SFR with attached garage		2002
New	Approved Basic #02-104622 BP	Plan: 110487 Two Story SFR - 1997 UBC	2002
New	Approved Basic 99-112322-BP	Plan: #1554. Two Story SFR 1997-UBC	2002
New	Approved Basic 99-112317-BP	Bldrs. Plan #1647 Two Story SFR 1997-UBC	2002
New	Approved Basic 99-112317-BP	Bldrs. Plan #1647 Two Story SFR 1997-UBC	2002
New	Approved Basic 99-112322-BP	BLDRS. PLAN #1554. Two Story SFR 1997-L	2002
New	Approved Basic #01-100447 BP	Plan: 498 2A Two Story SFR - 1997 UBC	2002
New	Approved Basic #02-100011 BP	Plan: 394 (2) A post & pier fndt Tri-Level Style SFI	2002
New	Two Story SFR - 1997 UBC	Plan: 487 3A (Post & Beam)	2002
New	Approved Basic #02-101970 BP	Plan: 394 (2) C Post & Pier Tri-Level SFR - 1997 UBC	2002
New	Approved Basic #01-100447 BP	Plan: 498 2A Two Story SFR - 1997 UBC	2002
New	Two Story SFR - 1997 UBC	Plan: 486 - 2A	2002
New	Two Story SFR - 1997 UBC	Plan: 498 2b	2002
New	Two Story SFR - 1997 UBC	Plan: 487 3B (Post & Beam)	2002
New	Approved Basic #02-103178 BP	Plan: 487 3A (Post & Beam) Two Story SFR - 1997 U	2002
New	Approved Basic #01-100447 BP	Plan: 498 2A Two Story SFR - 1997 UBC	2002
New	Two Story SFR - 1997 UBC	Plan: 488 - 3AX Post & Beam	2002
New	Approved Basic #01-100447 BP	Plan: 498 2A Two Story SFR - 1997 UBC	2002
New	Tri-level SFR w/3-car garage...1997 UBC	Bldrs Plan No. 394(3)B	2002
New	Approved Basic #02-100011 BP	Plan: 394 (2) A post & pier fndt Tri-Level Style SFI	2002
New	Approved Basic #01-100449 BP	Plan: 498 2B Two Story SFR - 1997 UBC	2002
New	Approved Basic #02-103178 BP	Plan: 487 3A (Post & Beam) Two Story SFR - 1997 U	2002
New	Approved Basic #02-103786 BP	Plan: 488 - 3Ax (post & beam) Two Story SFR - 1997 U	2002
New	Approved Basic #01-100447 BP	Plan: 498 2A Two Story SFR - 1997 UBC	2002
New	Approved Basic #00-108422 BP	Plan: 394(3)A Two Story SFR w/finished lc	2002
New	Approved Basic #01-100447 BP	Plan: 498 2A Two Story SFR - 1997 UBC	2002
New	Approved Basic #02-101970 BP	Plan: 394 (2) C Post & Pier Tri-Level SFR - 1997 UBC	2002
New	Approved Basic #01-107401BP	Plan: 1520 Rambler Style SFR - 1997 UBC	2002
New	2 story SFR w/ attached garage		2002
New	2 story SFR w/ attached garage		2002
New	27 x 56 - 2001- Golden West		2002
New	Rambler w/garage		2002
New	Approved Basic #02-104896 BP	Plan 2274 Rambler Style SFR - 1997 UBC	2002
New	Approved Basic #02-104896 BP	Plan 2274 Rambler Style SFR -1997 UBC	2002
New	1437 sf SFR w/attached garage		2002
New	2-story SFR w/attached garage		2002
New	Rambler w/ 3 Car		2002
New	Approved Basic #02-105640 BP	Plan: D 1335 A2F-0 Two Story Duplex - 1997 U	2002
New	27x48, 1995 Guerdon		2002
New	One-story SFR		2002
New	2 Story w/ 3 Car		2002

Accessory Dwelling Units

Index # - File Name: 1.0022 - Single Family Dwellings Data\_Snohomish County.pdf

New	2 Story w/ unfin basement & 3 Car		2002
New	2-story w/basement, garage and covered deck/porch		2002
New	26 -8 x 58 - 2002 - Marlette		2002
New	Daylight basement SFR - 1997UBC		2002
New	2-Story SFR over daylight basement w/attached garage.		2002
New	2156 Rambler		2002
New	2 story SFR with attached garage		2002
New	Two-story SFR		2002
New	Rambler w/finished basement, garage		2002
New	Split entry style SFR w/finished basement & garage in basement.		2002
New	Approved Basic #02-107293 BP	Plan: 668 Split Level - 1997 UBC	2002
New	Approved Basic #00-109218 BP	Plan: 453 Two Story SFR - 1997 UBC	2002
New	Approved Basic #00-109215 BP	Plan: 456 Two Story SFR - 1997 UBC	2002
New	Approved Basic #00-109214 BP	Plan: 454 Two Story SFR - 1997 UBC	2002
New	Approved Basic #00-109215 BP	Plan: 456 Two Story SFR - 1997 UBC	2002
New	Approved Basic #00-109214 BP	Plan: 454 Two Story SFR - 1997 UBC	2002
New	Approved Basic #00-109216 BP	Plan: 455 Two Story SFR - 1997 UBC	2002
New	Approved Basic #00-109218 BP	Plan: 453 Two Story SFR - 1997 UBC	2002
New	Approved Basic #00-109217 BP	Plan: 451 Two Story SFR - 1997 UBC	2002
New	Approved Basic #00-109215 BP	Plan: 456 Two Story SFR - 1997 UBC	2002
New	Approved Basic #00-109214 BP	Plan: 454 Two Story SFR - 1997 UBC	2002
New	Approved Basic #00-109215 BP	Plan: 456 Two Story SFR - 1997 UBC	2002
New	Approved Basic #00-109216 BP	Plan: 455 Two Story SFR - 1997 UBC	2002
New	Approved Basic #00-109218 BP	Plan: 453 Two Story SFR - 1997 UBC	2002
New	Approved Basic #00-109215 BP	Plan: 456 Two Story SFR - 1997 UBC	2002
New	Approved Basic #00-109218 BP	Plan: 453 Two Story SFR - 1997 UBC	2002
New	Approved Basic #00-109216 BP	Plan: 455 Two Story SFR - 1997 UBC	2002
New	Approved Basic #00-109214 BP	Plan: 454 Two Story SFR - 1997 UBC	2002
New	Approved Basic #00-109217 BP	Plan: 451 Two Story SFR - 1997 UBC	2002
New	Two Story SFR - 1997 UBC	Plan: 5212-B2-L	2002
New	Two Story SFR - 1997 UBC	Plan: 5411 B-A2-RG	2002
New	Two-story SFR - 1997 UBC	Plan 4011-B-L	2002
New	Two Story SFR - 1997 UBC	Plan: 5210-A2-R	2002
New	Two Story SFR - 1997 UBC	Plan: 5411 PB-B2-LG	2002
New	Two Story SFR - 1997 UBC	Plan: 5212-C2-R	2002
New	Two Story SFR - 1997 UBC	Plan: 5210-B2-LX4D	2002
New	Two Story SFR - 1997 UBC	Plan: 5212 B-A2-RD	2002
New	Two Story SFR - 1997 UBC	Plan: 5210-A2-LX4D	2002
New	Two Story SFR - 1997 UBC	Plan: 4011-C-RGD	2002
New	Two Story SFR - 1997 UBC	Plan: 5212 B-B2-LD	2002
New	Two Story SFR - 1997 UBC	Plan: 5411 PB-A2-RG	2002
New	Two Story SFR - 1997 UBC	Plan: 4011-C-L	2002
New	Two Story SFR - 1997 UBC	Plan: 5210-B2-R	2002
New	Two Story SFR - 1997 UBC	Plan: 5212-C2-L	2002
New	Two Story SFR - 1997 UBC	Plan: 5411 B-A-2-RG	2002
New	Two Story SFR - 1997 UBC	Plan: 5212 B-B2-R	2002
New	Two Story SFR - 1997 UBC	Plan: 4011-A-L	2002

Accessory Dwelling Units

Index # - File Name: 1.0022 - Single Family Dwellings Data\_Snohomish County.pdf

New	Two Story SFR - 1997 UBC	Plan: 5210-B2-R	2002
New	Two Story SFR - 1997 UBC	Plan: 5411-A2-L	2002
New	Two Story SFR - 1997 UBC	Plan: 4011 P-C-LG	2002
New	Two Story SFR - 1997 UBC	Plan: 5411-B2-L	2002
New	Two Story SFR - 1997 UBC	Plan: 4011-B-R	2002
New	Two-story SFR - 1997 UBC	Plan 4011-C-L	2002
New	Two Story SFR - 1997 UBC	Plan: 5411- P-C2-R	2002
New	Two Story SFR - 1997 UBC	Plan: 4011-B-RG	2002
New	Two Story SFR - 1997 UBC	Plan: 5212 B-B2-R	2002
New	Two Story SFR - 1997 UBC	Plan: 4011 P-A-LG	2002
New	Two Story SFR - 1997 UBC	Plan: 5411 - A2-L	2002
New	Two Story SFR - 1997 UBC	Plan: 4011 P-A-LGD	2002
New	Two Story SFR - 1997 UBC	Plan: 5411 B-B2-RG	2002
New	2 story SFR with daylight unfinished basement and attached garage		2002
New	Approved Basic #01-111809 BP	Plan: 2722 (Revised 2656) Rambler Style SFR w/bonus	2002
New	Approved Basic #02-110118 BP	Plan: 2985 Two-story SFR - 1997 UBC	2002
New	Approved Basic #02-108385 BP	Plan: 2042 C Two Story SFR - 1997 UBC	2002
New	Approved Basic #02-109233 BP	Plan: 2444 B Two Story SFR - 1997 UBC	2002
New	Approved Basic #02-107965 BP	Plan: 2132 A Two Story SFR - 1997 UBC	2002
New	Approved Basic #02-107552 BP	Plan: 2444 A Two Story SFR - 1997 UBC	2002
New	Approved Basic #02-107552 BP	Plan: 2444 A Two Story SFR - 1997 UBC	2002
New	Two-story SFR w/attached garage	Plan 2444	2002
New	Approved Basic #02-109233 BP	Plan: 2444 B Two Story SFR - 1997 UBC	2002
New	Approved Basic #02-108385 BP	Plan: 2042 C Two Story SFR - 1997 UBC	2002
New	Approved Basic #02-107552 BP	Plan: 2444 A Two Story SFR - 1997 UBC	2002
New	Approved Basic #02-107965 BP	Plan: 2132 A Two Story SFR - 1997 UBC	2002
New	Two-story SFR w/attached garage	Plan 2132	2002
New	Approved Basic #02-107552 BP	Plan: 2444 Two Story SFR - 1997 UBC	2002
New	Approved Basic #02-107965 BP	Plan: 2132 A Two Story SFR - 1997 UBC	2002
New	Approved Basic #02-107965 BP	Plan: 2132 A Two Story SFR - 1997 UBC	2002
New	Approved Basic #02-107552 BP	Plan: 2444 A Two Story SFR - 1997 UBC	2002
New	Approved Basic #02-107552 BP	Plan: 2444 Two Story SFR - 1997 UBC	2002
New	One-story SFR with attached two-story garage/storage		2002
New	28 x 60 2002 Marlette Lakecrest		2002
New	2002 Karsten 52 x 40		2002
New	30x75 2002 Guerdon doublewide		2002
New	Approved Basic #00-109157 BP	Plan: Rainier w/finished lower floor/unfin. basement Two Sto	2002
New	Approved Basic #98-116126BP	Plan 2704 - revised Two Story SFR - 1997 UBC	2002
New	2 Story w/ 3 Car		2002
New	Approved Basic #01-105631 BP	Plan: 3219 Two Story Style SFR....1997 UBC	2002
New	Approved Basic #02-107529 BP	Plan: 3219 (smaller garage) Two Story Style SFR.....:	2002
New	Approved Basic #02-108754 BP	Plan: 2780 Two Story SFR - 1997 UBC	2002
New	Approved Basic #02-106800 BP	Plan M2980A4FT-0 Two-story SFR - 1997 UBC	2002
New	Approved Basic #02-106800 BP	Plan M2980A4FT-0 Two-story SFR - 1997 UBC	2002
New	Approved Basic #02-106800 BP	Plan M2980A4FT-0 Two-story SFR - 1997 UBC	2002
New	One-story SFR with finished basement		2002
New	Approved Basic #01-105631 BP	Plan: 3219 Two Story Style SFR....1997 UBC	2002

Accessory Dwelling Units

Index # - File Name: 1.0022 - Single Family Dwellings Data\_Snohomish County.pdf

New	Approved Basic #98-116126BP	Plan 2704 - revised	Two Story SFR - 1997 UBC	2002
New	Approved Basic #01-105631 BP	Plan: 3219	Two Story Style SFR....1997 UBC	2002
New	One-story SFR with finished basement			2002
New	Approved Basic #01-107401BP	Plan: 1520	Rambler Style SFR - 1997 UBC	2002
New	Approved Basic #02-110008 BP	Plan 2024	Two-story SFR - 1997 UBC	2002
New	Approved Basic #02-110008 BP	Plan 2024	Two-story SFR - 1997 UBC	2002
New	2-Story Rambler style SFR w/attached garage.			2002
New	Approved Basic #02-103159 BP	Plan: 2180 SSI	Two Story SFR....1997 UBC	2002
New	Approved Basic #02-103157 BP	Plan No. 2108 SSI	Two Story SFR - 1997 UBC	2002
New	Approved Basic #01-107401BP	Plan: 1520	Rambler Style SFR - 1997 UBC	2002
New	2 story SFR with attached garage and covered porch			2002
New	Approved Basic #02-103157 BP	Plan No. 2108 SSI	Two Story SFR - 1997 UBC	2002
New	Approved Basic #02-103159 BP	Plan: 2180 SSI	Two Story SFR....1997 UBC	2002
New	Approved Basic #01-107401BP	Plan: 1520	Rambler Style SFR - 1997 UBC	2002
New	Approved Basic #01-107401BP	Plan: 1520	Rambler Style SFR - 1997 UBC	2002
New	Approved Basic #01-107401BP	Plan: 1520	Rambler Style SFR - 1997 UBC	2002
New	Approved Basic #98-110504BP	Plan #2195	Split Level SFR - 1997 UBC	2002
New	Approved Basic #02-105965 BP	Plan #2084	Two Story SFR - 1997 UBC	2002
New	Approved Basic #98-110504BP	Plan #2195	Split Level SFR - 1997 UBC	2002
New	Approved Basic #01-108242 BP	Plan No. 1896	2-story style SFR....1997 UBC	2002
New	Rambler w/ 2 Car			2002
New	Two Story SFR - 1997 UBC			2002
New	Approved Basic #02-108689-BP	Plan: 2002	Rambler Style SFR - 1997 UBC	2002
New	Two-story SFR - 1997 UBC	Plan 2001		2002
New	Two-story SFR - 1997 UBC	Plan 2103		2002
New	Two-story SFR - 1997 UBC	Plan 2013		2002
New	Two-story SFR - 1997 UBC	Plan 1677		2002
New	Two-story SFR - 1997 UBC	Plan 2001		2002
New	Two-story SFR - 1997 UBC	Plan: 2013	2-car	2002
New	Two Story SFR - 1997 UBC			2002
New	Rambler style SFR with attached garage			2002
New	Approved Basic #02-108265 BP	Plan: 2116	Two Story SFR - 1997 UBC	2002
New	Approved Basic #01-108242 BP	Plan No. 1896	2-story style SFR....1997 UBC	2002
New	Two Story SFR - 1997 UBC	Plan: 2002		2002
New	2 story SFR with daylight basement			2002
New	2-Story SFR over small finished area & Garages in basement.			2002
New	2-Story SFR w/attached garage.			2002
New	Approved Basic #02-105568 BP	Plan: 1573-2	Two Story SFR - 1997 UBC	2002
New	Approved Basic #02-105576 BP	Plan: 1885	Two Story SFR - 1997 UBC	2002
New	Approved Basic #02-105568 BP	Plan: 1573-2	Two Story SFR - 1997 UBC	2002
New	Two Story SFR - 1997 UBC	Plan: 1682 - B		2002
New	Approved Basic #02-105570 BP	Plan: 1682 (side entry)	Two Story SFR - 1997 UBC	2002
New	Approved Basic #02-105576 BP	Plan: 1885	Two Story SFR - 1997 UBC	2002
New	Approved Basic #02-105571 BP	Plan: 1682 -B	Two Story SFR - 1997 UBC	2002
New	Approved Basic #02-105570 BP	Plan: 1682 (side entry)	Two Story SFR - 1997 UBC	2002
New	Approved Basic #02-105568 BP	Plan: 1573-2	Two Story SFR - 1997 UBC	2002
New	Approved Basic #02-105574 BP	Plan: 1818	Two Story SFR - 1997 UBC	2002

Accessory Dwelling Units

Index # - File Name: 1.0022 - Single Family Dwellings Data\_Snohomish County.pdf

New	Approved Basic #02-105570 BP	Plan: 1682 (side entry) Two Story SFR - 1997 UBC	2002
New	Approved Basic #02-105576 BP	Plan: 1885 Two Story SFR - 1997 UBC	2002
New	Approved Basic #02-105572 BP	Plan: 1682 -B (side entry) Two Story SFR - 1997 UB	2002
New	Approved Basic #02-105568 BP	Plan: 1573-2 Two Story SFR - 1997 UBC	2002
New	Approved Basic #02-105570 BP	Plan: 1682 (side entry) Two Story SFR - 1997 UBC	2002
New	Approved Basic #02-105568 BP	Plan: 1573-2 Two Story SFR - 1997 UBC	2002
New	Approved Basic #02-105573 BP	Plan: 1799 Two Story SFR - 1997 UBC	2002
New	Approved Basic #02-105568 BP	Plan: 1573-2 Two Story SFR - 1997 UBC	2002
New	Approved Basic #02-105569 BP	Plan: 1682 Two Story SFR - 1997 UBC	2002
New	Approved Basic #02-100055 BP	Plan: 1615 Two Story SFR -1997 UBC	2002
New	Approved Basic #02-100055 BP	Plan: 1615 Two Story SFR -1997 UBC	2002
New	28 x 60 - 2003 - Redman STOP WORK 12/20/02 by Ted Irish--Grading in a critical area		2002
New	28 x 60 - 2003 - Redman		2002
New	28x60, 2002 Redman Discovery		2002
New	2-story w/unfinished basement & garage		2002
New	Approved Basic #02 106317 BP	Plan: 1059 Duplex Rambler style duplex - 1997 UBC	2002
New	Approved Basic #02-105568 BP	Plan: 1573-2 Two Story SFR - 1997 UBC	2002
New	Approved Basic #02-105570 BP	Plan: 1682 (side entry) Two Story SFR - 1997 UBC	2002
New	Approved Basic #02-105574 BP	Plan: 1818 Two Story SFR - 1997 UBC	2002
New	Approved Basic #02-105568 BP	Plan: 1573-2 Two Story SFR - 1997 UBC	2002
New	Two Story SFR - 1997 UBC	Plan: 1799	2002
New	Approved Basic #02-105576 BP	Plan: 1885 Two Story SFR - 1997 UBC	2002
New	Two Story SFR - 1997 UBC	Plan: 1818	2002
New	Two Story SFR - 1997 UBC	Plan: 1573	2002
New	Two Story SFR - 1997 UBC	Plan: 1682	2002
New	Approved Basic #02-105576 BP	Plan: 1885 Two Story SFR - 1997 UBC	2002
New	Approved Basic #02-105568 BP	Plan: 1573-2 Two Story SFR - 1997 UBC	2002
New	Approved Basic #02-105574 BP	Plan: 1818 Two Story SFR - 1997 UBC	2002
New	Approved Basic #02-105573 BP	Plan: 1799 Two Story SFR - 1997 UBC	2002
New	Split w/ 3 Car		2002
New	Two Story SFR - 1997 UBC		2002
New	Approved Basic #02-107917 BP	Plan: 2415 Two Story SFR - 1997 UBC	2002
New	Two Story SFR - 1997 UBC	Plan 2591	2002
New	Approved Basic #02-107917 BP	Plan: 2415 Two Story SFR - 1997 UBC	2002
New	Approved Basic #99-103777BP	Plan: 2415 A/3 Two Story SFR - 1997 UBC	2002
New	Approved Basic #02-109632 BP	Plan: 2591 Two Story SFR - 1997 UBC	2002
New	26 x 66 - 1994 - Guerdian		2002
New	Two Story SFR - 1997 UBC	Plan: 2366	2002
New	Approved Basic #02-107090 BP	Plan: 2294 Two Story SFR - 1997 UBC	2002
New	Approved Basic #02-109726 BP	Plan: 2493 Two Story SFR - 1997 UBC	2002
New	Approved Basic #00-110406 BP	Plan: 2415/pony wall revision Two Story SFR - 1997 U	2002
New	Approved Basic #99-103777BP	Plan: 2415 A/3 Two Story SFR - 1997 UBC	2002
New	Approved Basic #02-109543 BP	Plan: 2366 B Two Story SFR - 1997 UBC	2002
New	Approved Basic #00-110406 BP	Plan: 2415/pony wall revision Two Story SFR - 1997 U	2002
New	Approved Basic #02-109632 BP	Plan: 2591 Two Story SFR - 1997 UBC	2002
New	Approved Basic #02-107090 BP	Plan: 2294 Two Story SFR - 1997 UBC	2002
New	Approved Basic #02-109834 BP	Plan: 2366 A Two Story SFR - 1997 UBC	2002

Accessory Dwelling Units

Index # - File Name: 1.0022 - Single Family Dwellings Data\_Snohomish County.pdf

New	Two-story SFR - 1997 UBC	Bldrs Plan 2163	2002
New	2-Story SFR w/attached garage.		2002
New	Two-story SFR - 1997UBC	Bldrs Plan 2456	2002
New	Approved Basic #02-108442 BP	Plan: 2456 Two-story SFR - 1997 UBC	2002
New	Approved Basic #02-108442 BP	Plan: 2456 Two-story SFR - 1997 UBC	2002
New	Two-story SFR	Builders Plan: 2235	2002
New	Approved Basic #02-108527 BP	Plan #2235 Two Story SFR - 1997 UBC	2002
New	Approved Basic #02-108526 BP	Plan #2456 Two Story SFR - 1997 UBC	2002
New	2-Story SFR w/attached garage.		2002
New	Approved Basic #01-104901 BP	Plan: 2415 Two Story SFR - 1997 UBC	2002
New	Approved Basic #02-108527 BP	Plan #2235 Two Story SFR - 1997 UBC	2002
New	Two-story SFR - 1997 UBC	Plan: 1586	2002
New	Approved Basic #02-109478 BP	Plan: 1586 Two Story SFR - 1997 UBC	2002
New	Two-story SFR - 1997 UBC	Plan 668 E	2002
New	Approved Basic #02- 108794 BP	Plan #668 Split Level SFR - 1997 UBC	2002
New	Rambler w/attached garage	TAYLOR	2002
New	Rambler w/ attached garage	EVERGREEN	2002
New	Rambler w/ attached garage	TAYLOR	2002
New	Rambler w/ attached Garage	AMBER-A	2002
New	Rambler w/attached garage	TAYLOR	2002
New	Rambler w/attached garage	EVERGREEN	2002
New	Rambler w/ attached garage	EVERGREEN	2002
New	2 story SFR w/attached garage	AMBER-A	2002
New	Rambler w/ attached garage	TAYLOR	2002
New	Rambler w/ attached garage	EVERGREEN	2002
New	SFR w/unfinished basement and attached garage	SHASTA	2002
New	One story SFR w/finished basement - 1997 UBC		2002
New	Approved Basic #02-109726 BP	Plan: 2493 Two Story SFR - 1997 UBC	2002
New	Approved Basic #00-100924 BP	Plan: 2405 Two Story SFR - 1997 UBC	2002
New	Approved Basic #00-100924 BP	Plan: 2405 Two Story SFR - 1997 UBC	2002
New	Approved Basic #02-109543 BP	Plan: 2366 B Two Story SFR - 1997 UBC	2002
New	2 story SFR w/ attached garage		2002
New	2 story SFR w/ attached garage		2002
New	Split-level entry SFR - 1997 UBC	Bldrs Plan 1926	2002
New	Approved Basic #02-109465 BP	Plan: 2509 Two-story SFR 1997 UBC	2002
New	Approved Basic #01-112969 BP	Plan No. 2321 Mid-entry SFR - 1997 UBC	2002
New	2 story SFR w/attached garage		2002
New	Approved Basic #01-112969 BP	Plan No. 2321 Mid-entry SFR - 1997 UBC	2002
New	Two-story SFR - 1997 UBC	Bldrs Plan 1944	2002
New	Two-story SFR - 1997 UBC	Plan: 2390 B The Chelsea	2002
New	Two-story SFR - 1997 UBC	Plan: 2448 A	2002
New	Two-story SFR - 1997 UBC	Plan: 2448 B	2002
New	2 story SFR w/attached garage		2002
New	Two-story SFR - 1997 UBC	Plan: 2390 B The Chelsea	2002
New	Two-story SFR - 1997UBC	Bldrs Plan 2311	2002
New	Two Story SFR with Attached Garage	Plan #M2980B4FT-2	2002
New	Approved Basic #02-110237 BP	Plan: 2311 Two Story SFR - 1997 UBC	2002

Accessory Dwelling Units

Index # - File Name: 1.0022 - Single Family Dwellings Data\_Snohomish County.pdf

New	Approved Basic #02-110232 BP	Plan: 1944 Two Story SFR - 1997 UBC	2002
New	Two-story SFR - 1997 UBC	Bldrs Plan 2509	2002
New	Approved Basic #02-106231 BP	Plan: Stewart/Gable (C) SFR w/finished lower floor	2002
New	Approved Basic #02-106235 BP	Plan: Adams/Gable (C) Two Story SFR - 1997 UBC	2002
New	Approved Basic #02-106229 BP	Plan: Whitney/Gable (B) Two Story SFR - 1997 UB	2002
New	Approved Basic #02-106236 BP	Plan: Olympic/Gable (C) Two Story SFR - 1997 UB	2002
New	Approved Basic #02-106232 BP	Plan: Baker/Gable (C) SFR w/finished basement -	2002
New	Approved Basic #02-106234 BP	Plan: Siskiyou/Gable Two Story SFR - 1997 UBC	2002
New	Approved Basic #02-106228 BP	Plan: Whitney - Hip (C) Two Story SFR - 1997 UBC	2002
New	Approved Basic #02-106234 BP	Plan: Siskiyou/Gable Two Story SFR - 1997 UBC	2002
New	Approved Basic #02-106235 BP	Plan: Adams/Gable (C) Two Story SFR - 1997 UBC	2002
New	Approved Basic #02-106229 BP	Plan: Whitney/Gable (B) Two Story SFR - 1997 UB	2002
New	Approved Basic #02-106235 BP	Plan: Adams/Gable (C) Two Story SFR - 1997 UBC	2002
New	Approved Basic #02-106236 BP	Plan: Olympic/Gable (C) Two Story SFR - 1997 UB	2002
New	Approved Basic #02-106227 BP	Plan: Trinity/Gable (C) Two Story SFR - 1997 UBC	2002
New	Approved Basic #02-106228 BP	Plan: Whitney - Hip (C) Two Story SFR - 1997 UBC	2002
New	Approved Basic #02-106233 BP	Plan: Shasta/Gable (B) Two Story SFR - 1997 UBC	2002
New	Approved Basic #02-106235 BP	Plan: Adams/Gable (C) Two Story SFR - 1997 UBC	2002
New	Approved Basic #02-106228 BP	Plan: Whitney - Hip (C) Two Story SFR - 1997 UBC	2002
New	Approved Basic #02-106228 BP	Plan: Whitney - Hip (C) Two Story SFR - 1997 UBC	2002
New	Approved Basic #02-106227 BP	Plan: Trinity/Gable (C) Two Story SFR - 1997 UBC	2002
New	Approved Basic #02-106236 BP	Plan: Olympic/Gable (C) Two Story SFR - 1997 UB	2002
New	Approved Basic #02-106233 BP	Plan: Shasta/Gable (B) Two Story SFR - 1997 UBC	2002
New	Approved Basic #02-107156 BP	Plan: 2155-A Two Story SFR - 1997 UBC	2002
New	Approved Basic #02-107153 BP	Plan: 2452-A Two Story SFR - 1997 UBC	2002
New	Approved Basic #02-107151 BP	Plan: 2565-B Two Story SFR - 1997 UBC	2002
New	Approved Basic #02-107152 BP	Plan: 2741 A Two Story SFR - 1997 UBC	2002
New	Approved Basic #02-107152 BP	Plan: 2741 A Two Story SFR - 1997 UBC	2002
New	Approved Basic #02-107151 BP	Plan: 2565-B Two Story SFR - 1997 UBC	2002
New	Approved Basic #01-101344 BP	Plan: 1460 S SFR w/finished lower floor - 1997 UBC	2002
New	Approved Basic #02-108290 BP	Plan: 1525 C SFR w/finished basement - 1997 U	2002
New	Approved Basic #02- 108288 BP	Plan: 1404 Two Story w/finished basement - 1	2002
New	Approved Basic #02- 1028288 BP	Plan: 1404 Two Story w/finished basement -	2002
New	Approved Basic #01-101344 BP	Plan: 1460 S SFR w/finished lower floor - 1997 UBC	2002
New	Approved Basic #01-104718 BP	Plan: 1760 S/H Split Level SFR - 1997 UBC	2002
New	Approved Basic #02-108290 BP	Plan: 1525 C SFR w/finished basement - 1997 U	2002
New	Approved Basic #02-100245 BP	Plan: 1644 Two Story SFR - 1997 UBC	2002
New	Approved Basic #02-100245 BP	Plan: 1644 Two Story SFR - 1997 UBC	2002
New	Approved Basic #01-104718 BP	Plan: 1760 S/H Split Level SFR - 1997 UBC	2002
New	Approved Basic #02-107154 BP	Plan: 2741 C Two Story SFR - 1997 UBC	2002
New	Two Story SFR - 1997 UBC	Plan: Camden II	2002
New	Two Story SFR - 1997 UBC		2002
New	Two Story SFR - 1997 UBC		2002
New	Approved Basic #02-108534 BP	Plan: Patrick II Rambler Style SFR - 1997 UBC	2002
New	Approved Basic #02-108613 BP	Plan: Auburn II Rambler Style SFR - 1997 UBC	2002
New	Approved Basic #02-108535 BP	Plan: Everett II Two Style SFR - 1997 UBC	2002
New	Approved Basic #02-107112 BP	Plan #1956 Two Story SFR - 1997 UBC	2002

Accessory Dwelling Units

Index # - File Name: 1.0022 - Single Family Dwellings Data\_Snohomish County.pdf

New	Approved Basic #02-106830 BP	Plan #2294	Two Story SFR - 1997 UBC	2002
New	Approved Basic #02-107112 BP	Plan #1956	Two Story SFR - 1997 UBC	2002
New	Approved Basic #02-106832 BP	Plan: 1974 A	Two-story SFR - 1997 UBC	2002
New	Approved Basic #02-106831 BP	Plan: 1974 B	Two-story SFR - 1997 UBC	2002
New	Approved Basic #02-107112 BP	Plan #1956	Two Story SFR - 1997 UBC	2002
New	Approved Basic #02-106830 BP	Plan #2294	Two Story SFR - 1997 UBC	2002
New	Approved Basic #02-106832 BP	Plan: 1974 A	Two-story SFR - 1997 UBC	2002
New	Approved Basic #02-106831 BP	Plan: 1974 B	Two-story SFR - 1997 UBC	2002
New	Approved Basic #02-107152 BP	Plan: 2741 A	Two Story SFR - 1997 UBC	2002
New	SFR w/finished lower floor - 1997 UBC	Plan: 2407		2002
New	Approved Basic #02-109375 BP	Plan: 2294	Two Story SFR - 1997 UBC	2002
New	Approved Basic #02-109374 BP	Plan: 2407	SFR w/finished lower floor - 1997 U	2002
New	Approved Basic #02-109375 BP	Plan: 2294	Two Story SFR - 1997 UBC	2002
New	Approved Basic #02-109374 BP	Plan: 2407	SFR w/finished lower floor - 1997 U	2002
New	Approved Basic #02-109376 BP	Plan: 2127	Two Story SFR - 1997 UBC	2002
New	Approved Basic #02-109586 BP	Plan #2016	Two Story SFR - 1997 UBC	2002
New	Approved Basic #02-109376 BP	Plan: 2127	Two Story SFR - 1997 UBC	2002
New	Approved Basic #02-109376 BP	Plan: 2127	Two Story SFR - 1997 UBC	2002
New	Approved Basic #02-109375 BP	Plan: 2294	Two Story SFR - 1997 UBC	2002
New	Approved Basic #02-109586 BP	Plan: 2016	Two Story SFR - 1997 UBC	2002
New	2-Story SFR w/attached garage.			2002
New	Two Story SFR - 1997 UBC	Plan: 2294		2002
New	Two Story SFR - 1997 UBC	Plan: 2127		2002
New	Approved Basic #02- 108794 BP	Plan #668	Split Level SFR - 1997 UBC	2002
New	Approved Basic #02-107156 BP	Plan: 2155-A	Two Story SFR - 1997 UBC	2002
New	Approved Basic #02-107151 BP	Plan: 2565-B	Two Story SFR - 1997 UBC	2002
New	Approved Basic #02-108413BP	Plan: 2006	Two-story SFR - 1997 UBC	2002
New	Approved Basic #02-107152 BP	Plan: 2741 A	Two Story SFR - 1997 UBC	2002
New	Approved Basic #02-107155 BP	Plan: 2565-A	Two Story SFR - 1997 UBC	2002
New	2003 26 x 60 Redman			2002
New	Approved Basic #02-109360 BP	Plan #2443A	Two Story SFR - 1997 UBC	2002
New	Approved Basic #02-109361 BP	Plan 2553 B	Two Story SFR - 1997 UBC	2002
New	Approved Basic #02-109360 BP	Plan #2443A	Two Story SFR - 1997 UBC	2002
New	Approved Basic #02-106289-BP	Plan: 0228-A1	Rambler style SFR - 1997 UBC, 20	2002
New	Approved Basic #02-106291-BP	Plan: 1838-A1	2-Story SFR - 1997 UBC, 2001 WSE	2002
New	2-Story SFR w/atached garage			2002
New	Approved Basic #02-106983 BP	Plan: 01108	Rambler Style SFR - 1997 UBC	2002
New	Approved Basic #02-109714 BP	Plan #1404	Rambler Style SFR - 1997 UBC	2002
New	Approved Basic #02-109714 BP	Plan #1404	Rambler Style SFR - 1997 UBC	2002
New	Approved Basic #02-109714 BP	Plan #1404	Rambler Style SFR - 1997 UBC	2002
New	Approved Basic #02-109811 BP	Plan: 1576	Rambler Style SFR - 1997 UBC	2002
New	Approved Basic #01-111402 BP	Plan: 1680-revised engineering	Two-Story style SFR..	2002
New	Approved Basic #02-100832 BP	Plan: 1455	Split Level SFR - 1997 UBC	2002
New	Approved Basic #02-100273 BP	Plan: 2117	Split Level SFR - 1997 UBC	Opti 2002
New	Approved Basic #02-100274 BP	Plan: 1710	Two Story SFR - 1997 UBC	Option 2002
New	Approved Basic #02-100832 BP	Plan: 1455	Split Level SFR - 1997 UBC	2002
New	Approved Basic #02-100273 BP	Plan: 2117	Split Level SFR - 1997 UBC	Opti 2002



Accessory Dwelling Units

Index # - File Name: 1.0022 - Single Family Dwellings Data\_Snohomish County.pdf

New	Approved Basic #01-111402 BP	Plan: 1680-revised engineering	Two-Story style SFR..	2002
New	Approved Basic #01-105212 BP	Plan: 1538	Two Story SFR - 1997 UBC	2002
New	Approved Basic #01-111402 BP	Plan: 1680-revised engineering	Two-Story style SFR..	2002
New	Approved Basic #02-109809 BP	Plan: Jessica II	Rambler Style SFR - 1997 UBC	2002
New	Rambler Style SFR - 1997 UBC	Plan: 1404-3		2002
New	Rambler Style SFR - 1997 UBC	Plan: 1404		2002
New	Two Story SFR - 1997 UBC	Plan: 1362		2002
New	2-story SFR w/attached garage.			2002
New	Rambler Style SFR - 1997 UBC			2002
New	Rambler style SFR w/attached garage.			2002
New	Rambler Style SFR - 1997 UBC			2002
New	Approved Basic #02-100274 BP	Plan: 1710	Two Story SFR - 1997 UBC	Option 2002
New	Approved Basic #02-109388 BP	Plan: 1575	Tri-Level SFR - 1997 UBC	Option 2002
New	Approved Basic #02-100274 BP	Plan: 1710	Two Story SFR - 1997 UBC	Option 2002
New	Approved Basic #02-100832 BP	Plan: 1455	Split Level SFR - 1997 UBC	2002
New	Approved Basic #02-100273 BP	Plan: 2117	Split Level SFR - 1997 UBC	Opti 2002
New	Approved Basic #02-100832 BP	Plan: 1455	Split Level SFR - 1997 UBC	2002
New	Approved Basic #02-109811 BP	Plan: 1576	Rambler Style SFR - 1997 UBC	2002
New	Approved Basic #02-109388 BP	Plan: 1575	Tri-Level SFR - 1997 UBC	Opt 2002
New	Approved Basic #02-100274 BP	Plan: 1710	Two Story SFR - 1997 UBC	Option 2002
New	Approved Basic #02-100274 BP	Plan: 1710	Two Story SFR - 1997 UBC	Option 2002
New	Approved Basic #02-100274 BP	Plan: 1710	Two Story SFR - 1997 UBC	Option 2002
New	Approved Basic #02-100274 BP	Plan: 1710	Two Story SFR - 1997 UBC	Option 2002
New	Approved Basic #02-100273 BP	Plan: 2117	Split Level SFR - 1997 UBC	Opti 2002
New	Approved Basic #02-100274 BP	Plan: 1710	Two Story SFR - 1997 UBC	Option 2002
New	Approved Basic #01-111402 BP	Plan: 1680-revised engineering	Two-Story style SFR..	2002
New	Approved Basic #02-100832 BP	Plan: 1455	Split Level SFR - 1997 UBC	2002
New	2-Story SFR w/attached garage.			2002
New	2 Story SFR w/ 3 Car gargage			2002
New	Approved Basic #02-109632 BP	Plan: 2591	Two Story SFR - 1997 UBC	2002
New	Two Story SFR - 1997 UBC	Plan: 2493		2002
New	Approved Basic #02-109543 BP	Plan: 2366 B	Two Story SFR - 1997 UBC	2002
New	Two Story SFR - 1997 UBC	Plan: 2486		2002
New	Two Story SFR - 1997 UBC	Plan: 2552		2002
New	Approved Basic #02-107917 BP	Plan: 2415	Two Story SFR - 1997 UBC	2002
New	Approved Basic #02-108950 BP	Plan: 2780	Two Story SFR - 1997 UBC	2002
New	Approved Basic #01-106082 BP	Plan: 2195-0	One-story SFR w/finished base	2002
New	Approved Basic #00-108550 BP	Plan: 2294 A	Two Story SFR - 1997 UBC	Optio 2002
New	Approved Basic #02-107532 BP	Plan: 2195 A	Split SFR w/finished lower flo	2002
New	Approved Basic #01-106082 BP	Plan: 2195-0	One-story SFR w/finished base	2002
New	Approved Basic #02-107532 BP	Plan: 2195 A	Split SFR w/finished lower flo	2002
New	Approved Basic #02-107532 BP	Plan: 2195 A	Split SFR w/finished lower flo	2002
New	Approved Basic #01-106082 BP	Plan: 2195-0	One-story SFR w/finished base	2002
New	Approved Basic #02-107532 BP	Plan: 2195 A	Split SFR w/finished lower flo	2002
New	Approved Basic #00-108550 BP	Plan: 2294 A	Two Story SFR - 1997 UBC	Optio 2002
New	Approved Basic #00-108548 BP	Plan: 2127 front garage	Two Story SFR - 1997 UE	2002
New	Approved Basic #00-108548 BP	Plan: 2127 front garage	Two Story SFR - 1997 UE	2002
New	Approved Basic #00-108551 BP	Plan: 2127 w/basement	Two Story SFR w/finishec	2002

Accessory Dwelling Units

Index # - File Name: 1.0022 - Single Family Dwellings Data\_Snohomish County.pdf

New	Approved Basic #02-109590 BP	Plan: 2683	Two Story SFR - 1997 UBC	2002
New	Approved Basic #02-109632 BP	Plan: 2591	Two Story SFR - 1997 UBC	2002
New	2-Story SFR w/attached garage.			2002
New	Approved Basic #02-109724 BP	Plan: 2486	Two Story SFR - 1997 UBC	2002
New	Two Story SFR - 1997 UBC	Plan: 2591		2002
New	Approved Basic #02-109543 BP	Plan: 2366 B	Two Story SFR - 1997 UBC	2002
New	Approved Basic #02-109726 BP	Plan: 2493	Two Story SFR - 1997 UBC	2002
New	Two Story SFR - 1997 UBC	Plan: 2510		2002
New	Approved Basic #00-108551 BP	Plan: 2127 w/basement	Two Story SFR w/finished	2002
New	Approved Basic #02-107746 BP	Plan: 1317 Duplex	Two Story Duplex - 1997 UBC	2002
New	Approved Basic #01-106082 BP	Plan: 2195-0	One-story SFR w/finished base	2002
New	Approved Basic #02-107746 BP	Plan: 1317 Duplex	Two Story Duplex - 1997 UBC	2002
New	SFR above 3 Car Garage			2002
New	Two-story SFR - 1997 UBC	Bldrs Plan 2123-3		2002
New	Approved Basic #02-107345 BP	Plan: 2461	Two Story SFR - 1997 UBC	2002
New	Approved Basic #01-105185 BP	Plan: 2415	Two Story SFR - 1997 UBC	2002
New	Approved Basic #02-107345 BP	Plan: 2461	Two Story SFR - 1997 UBC	2002
New	Approved Basic #01-105185 BP	Plan: 2415	Two Story SFR - 1997 UBC	2002
New	Split Entry w/ 2 Car			2002
New	Two Story SFR - 1997 UBC			2002
New	Approved Basic #02-109607 BP	Plan #2265 C/2-3	Two Story SFR - 1997 UBC	2002
New	Approved Basic #00-104229 BP	Plan: 1533 revised	Two Story SFR - 1997 UE	2002
New	Approved Basic #00-104229 BP	Plan: 1533 revised	Two Story SFR - 1997 UE	2002
New	Approved Basic #02-102104-BP	Plan: 1420 - Rambler	Rambler Style SFR - 1997 UBC	2002
New	Approved Basic #02-102104-BP	Plan: 1420 - Rambler	Rambler Style SFR - 1997 UBC	2002
New	Approved Basic #00-104229 BP	Plan: 1533 revised	Two Story SFR - 1997 UE	2002
New	2002 Palm Harbor 5V452E9 52 x 40			2002
New	Approved Basic #02-109015 BP	Plan: 1813	Rambler Style SFR - 1997 UBC	2002
New	Rambler Style SFR - 1997 UBC	Plan: 1722		2002
New	Approved Basic #02-109847 BP	Plan:1208 Duplex	Two Story Duplex - 1997 UBC	2002
New	Approved Basic #02-109847 BP	Plan:1208 Duplex	Two Story Duplex - 1997 UBC	2002
New	2 Story w/ covered porch			2002
New	One-story SFR			2002
New	2-story style SFR - 1997 UBC			2002
New	One-story SFR w/attached garage			2002
New	Conversion of 384sf unfinished basement to finished - 1997 UBC			2002
New	Rambler w/garage			2002
New	1834sf SFR with 832sf finished basement - 1997UBC			2002
New	2266 sf 2-story w/360 sf garage and 134 sf covered deck/porch			2002
New	2266 sf 2-story w/360 sf garage & 134 sf covered deck/porch			2002
New	Two-story SFR with attached garage - 1997 UBC			2002
New	Approved Basic #02-100483 BP	Plan: 2220S	Mid-Entry SFR - 1997 UBC	2002
New	2 Story w/ 3 Car			2002
New	3940 sf 2-story w/890 sf garage, 568 sf covered deck/porch and 280 sf open deck			2002
New	This is a renewal of the issued RK. Customer decided to come back at a later date to complete r			2002
New	Rambler style SFR....1997 UBC			2002
New	Two Story SFR with Attached Garage			2002

Accessory Dwelling Units

Index # - File Name: 1.0022 - Single Family Dwellings Data\_Snohomish County.pdf

New	Two Story SFR w/semi-finished basement - 1997 UBC		2002
New	Two-story SFR w/attached garage		2002
New	Two-story SFR w/attached garage		2002
New	Two Story SFR - 1997 UBC		2002
New	2-story SFR w/unfinished basement & attached carport.....1997 UBC		2002
New	2-story w/ garage and covered porch/deck		2002
New	Two-story SFR w/attached garage		2002
New	2-story w/garage		2002
New	Approved Basic #00-109239 BP	Plan: 1840 Elv. B Two Story SFR - 1997 UBC	2002
New	Approved Basic #01-108192BP	Plan: 2397 Two-story SFR - 1997 UBC	2002
New	Approved Basic #01-104132 BP	Plan: 2895 Two Story SFR - 1997 UBC	2002
New	Approved Basic #01-108192BP	Plan: 2397 Two-story SFR - 1997 UBC	2002
New	Approved Basic #99-113027 BP	Plan: 2621 Two Story SFR - 1997 U	2002
New	Approved Basic #99-109806 BP	Plan: 2628 Two Story SFR - 1997 UBC	2002
New	Approved Basic #01-104132 BP	Plan: 2895 Two Story SFR - 1997 UBC	2002
New	Two-story SFR w/attached garage		2002
New	Approved Basic #99-116397 BP	Plan: Trisha - Mid-Entry Mid-Entry Style SFR w/fir	2002
New	Approved Basic #01-111402 BP	Plan: 1680-revised engineering Two-Story style SFR..	2002
New	Approved Basic #98-116510BP	Plan: 1610 C/2 Two-story SFR - 1997 UBC	2002
New	Approved Basic #99-116397 BP	Plan: Trisha - Mid-Entry Mid-Entry Style SFR w/fir	2002
New	2002 27x52 Skyline/Greenbriar		2002
New	Approved Basic #99-104694BP	Plan: Georgetown Two Story SFR - 1997 UBC	2002
New	Approved Basic #99-104694BP	Plan: Georgetown Two Story SFR - 1997 UBC	2002
New	Approved Basic #99-104694BP	Plan: Georgetown Two Story SFR - 1997 UBC	2002
New	Two Story SFR w/unfinished basement - 1997 UBC		2002
New	Approved Basic #99-104694BP	Plan: Georgetown Two Story SFR - 1997 UBC	2002
New	Rambler style SFR w/attached garage.		2002
New	One-story SFR w/attached garage		2002
New	One-story SFR with attached garage & carport - 1997 UBC		2002
New	Rambler with Attached Garage		2002
New	Two Story SFR with Attached Garage		2002
New	Rambler style SFR w/attached garage.		2002
New	27x67, 2003 Fleetwood		2002
New	Two Story SFR with Attached Garage		2002
New	Two story SFR with Attached Garage		2002
New	Two-story SFR - 1997UBC	Bldr s Plan 2817	2002
New	2609 sf 2-story w/674sf garage, 52 sf covered deck/porch , and 168 sf open deck		2002
New	Two Story SFR with Attached Garage		2002
New	Approved Basic #02-100809 BP	Plan: 2002 Gable Two Story SFR - 1997 UBC	2002
New	Approved Basic #02-100810 BP	Plan: #2002 Hip Two Story SFR - 1997 UBC	2002
New	2-story SFR w/attached 2-car garage....1997 UBC	Blders Plan No. 2	2002
New	Approved Basic #00-104213 BP	Plan: 5 Two Story SFR - 1997 UBC	2002
New	52 x 27 - 2002 - Marlette		2002
New	Approved Basic #00-104213 BP	Plan: 5 Two Story SFR - 1997 UBC	2002
New	Approved Basic #01-111887 BP	Plan: 2a Two Story SFR - 1997 UBC	2002
New	Two Story SFR - 1997 UBC. REF. 99-114854.		2002
New	Two-story SFR w/unfinished basement		2002

Accessory Dwelling Units

Index # - File Name: 1.0022 - Single Family Dwellings Data\_Snohomish County.pdf

New	544 SF Living Quarters w/4016 Garage & unheated upstairs storage		2002
New	2 story SFR with attached garage		2002
New	Daylight basement rambler style SFR with attached garage/shop and covered porches.		2002
New	1847 sf 2-story w/927 sf unfinished basement, 576 sf garage, 165 sf covered deck/porch and 38		2002
New	2-Story SFR w/attached garage.		2002
New	2 story SFR with attached garage		2002
New	2499sf SFR with 463sf 2nd story bonus room - 1997 UBC		2002
New	Rambler style SFR with attached garage		2002
New	2723 Sq Ft Rambler		2002
New	1814 sf 2-story w/672 sf garage and 208 sf covered deck/porch		2002
New	Rambler style SFR w/attached garage		2002
New	40 X 60 Valley 2002		2002
New	One-story SFR with attached garage and bonus rooms - 1997 UBC		2002
New	Two story style SFR....1997 UBC		2002
New	Approved Basic #02-109499 BP	Plan: 1344 Split Level SFR - 1997 UBC	2002
New	28x48 (1976) Gordon		2002
New	Rambler Style SFR with attached garage		2002
New	Approved Basic #99-113971 BP	Plan: 1315 Split Level SFR - 1997 UBC	2002
New	Approved Basic #99-113971 BP	Plan: 1315 Split Level SFR - 1997 UBC	2002
New	816 s.f. w/468 s.f. finished basement & 1 car garage		2002
New	Two Story SFR.....1997 UBC	Plan: 2056	2002
New	Rambler w/ 3 Car		2002
New	1986 Capma Capital Cape 66 x 14		2002
New	Approved Basic #02-102778 BP	Plan: 1174 Two-Story SFR - 1997 UBC	2002
New	Approved Basic #01-111544 BP	Plan: 1008 Rambler Style SFR - 1997 UBC	2002
New	Approved Basic #01-111544 BP	Plan: 1008 Rambler Style SFR - 1997 UBC	2002
New	40 X 66 Silver Crest Manor 2002		2002
New	2-story w/garage		2002
New	3 story SFR with finished basement and attached garage		2002
New	Approved Basic #01-107443 BP	Plan: 2222 Two-story SFR w/finished basement..	2002
New	2 story SFRw/ attached garage with bonus room above	The Chateau	2002
New	2 story SFRw/ finished basement and attached garage		2002
New	Two-story SFR		2002
New	Approved Basic #01-107443 BP	Plan: 2222 Two-story SFR w/finished basement..	2002
New	Two-story SFR w/attached garage		2002
New	Two-story SFR		2002
New	Approved Basic #01-106757 BP	Plan: 706 - revised Two Story SFR - 1997 UBC	2002
New	2002 28 x 66 Golden West		2002
New	Two-story SFR w/garage		2002
New	Approved Basic #99-104545BP	Two Story SFR - 1997 UBC	2002
New	Rambler Style SFR - 1997 UBC		2002
New	Approved Basic #02-105374 BP	Plan: 2017 K Two Story SFR - 1997 UBC	2002
New	60 x 44 Two Story SFR with Attached Garage	Bldrs Plan # 2413	2002
New	Two Story SFR with Attached Garage	Builders Plan #2200	2002
New	One-story SFR - 1997UBC		2002
New	2-Story SFR w/attached garage.		2002
New	2-story SFR w/attached garage.		2002

Accessory Dwelling Units

Index # - File Name: 1.0022 - Single Family Dwellings Data\_Snohomish County.pdf

New	Approved Basic #98-110563BP	Plan 2146 Two Story SFR - 1997 UBC	2002
New	Approved Basic #00-103631 BP	Plan: 1745 Two Story SFR - 1997 UBC	2002
New	Approved Basic #99-114285 BP	Plan # Aspen 2 Two Story SFR - 1997 UBC	2002
New	Approved Basic #01-105986 BP	Plan: 2033 Two Story SFR - 1997 UBC	2002
New	Approved Basic #01-112795 BP	Plan: 1855 - revised Two Story SFR - 1997 UBC	2002
New	Approved Basic #00-109002 BP	Plan: 2008 A2 S-2 Two Story SFR - 1997 UBC	2002
New	Approved Basic #00-109378 BP	Plan: 2388 Two Story SFR - 1997 UBC	2002
New	Approved Basic #01-105987 BP	Plan: 2138 Two Story SFR - 1997 UBC	2002
New	Approved Basic #00-109378 BP	Plan: 2388 Two Story SFR - 1997 UBC	2002
New	Approved Basic #00-109002 BP	Plan: 2008 A2 S-2 Two Story SFR - 1997 UBC	2002
New	Approved Basic #00-109209 BP	Plan 2146 Two Story SFR - 1997 UBC	2002
New	Approved Basic #01-105987 BP	Plan: 2138 Two Story SFR - 1997 UBC	2002
New	Two Story SFR - 1997 UBC	Plan: 1786	2002
New	Approved Basic #01-103301 BP	Plan #2294 A2 F-2 DB Two Story SFR - 1997 U	2002
New	Approved Basic #01-100548 BP	Plan 2146 w/basement Two Story SFR w/finished	2002
New	Approved Basic #01-103301 BP	Plan #2294 A2 F-2 DB Two Story SFR - 1997 U	2002
New	Approved Basic #01-100548 BP	Plan 2146 w/basement Two Story SFR w/finished	2002
New	Approved Basic #01-105986 BP	Plan: 2033 Two Story SFR - 1997 UBC	2002
New	Approved Basic #00-109207 BP	Plan #2294 A2 F-2 Two Story SFR - 1997 UBC	2002
New	Approved Basic #00-109378 BP	Plan: 2388 Two Story SFR - 1997 UBC	2002
New	Approved Basic #01-110578 BP	Plan: 2590 A Two Story SFR - 1997 UBC	2002
New	Approved Basic #01-105986 BP	Plan: 2033 Two Story SFR - 1997 UBC	2002
New	Approved Basic #00-109378 BP	Plan: 2388 Two Story SFR - 1997 UBC	2002
New	Approved Basic #01-105987 BP	Plan: 2138 Two Story SFR - 1997 UBC	2002
New	Approved Basic #01-105986 BP	Plan: 2033 Two Story SFR - 1997 UBC	2002
New	Approved Basic #01-110578 BP	Plan: 2590 A Two Story SFR - 1997 UBC	2002
New	Approved Basic #01-110576 BP	Plan: 1905 2/3 Two Story SFR - 1997 UBC	2002
New	2-Story SFR over Basement garage.		2002
New	Approved Basic #01-106258 BP	Plan: 2032-BL Two Story SFR - 1997 UBC	2002
New	Approved Basic #01-106258 BP	Plan: 2032-BL Two Story SFR - 1997 UBC	2002
New	Approved Basic #01-106258 BP	Plan: 2032-BL Two Story SFR - 1997 UBC	2002
New	Approved Basic #01-101434 BP	Plan: 2042 Two Story SFR - 1997 UBC	2002
New	Approved Basic #01-101438 BP	Plan: 2409 C Two Story SFR - 1997 UBC	2002
New	Approved Basic #01-101439 BP	Plan: 2409 A Two Story SFR - 1997 UBC	2002
New	Approved Basic #01-106258 BP	Plan: 2032-BL Two Story SFR - 1997 UBC	2002
New	Approved Basic #01-101434 BP	Plan: 2042 Two Story SFR - 1997 UBC	2002
New	Approved Basic #01-101434 BP	Plan: 2042 Two Story SFR - 1997 UBC	2002
New	Approved Basic #01-101435 BP	Plan: 2598 Two Story SFR - 1997 UBC	2002
New	Approved Basic #01-101438 BP	Plan: 2409 C Two Story SFR - 1997 UBC	2002
New	Approved Basic #01-101438 BP	Plan: 2409 C Two Story SFR - 1997 UBC	2002
New	Approved Basic #01-101439 BP	Plan: 2409 A Two Story SFR - 1997 UBC	2002
New	Approved Basic #01-101434 BP	Plan: 2042 Two Story SFR - 1997 UBC	2002
New	Approved Basic #01-101439 BP	Plan: 2409 A Two Story SFR - 1997 UBC	2002
New	Approved Basic #01-103531 BP	Plan: 1740/A Two Story SFR - 1997 UBC	2002
New	Approved Basic #01-101438 BP	Plan: 2409 C Two Story SFR - 1997 UBC	2002
New	Approved Basic#01-112389 BP	Plan: 1740 Side Garage Two Story SFR - 1997 U	2002
New	10x55, 1964 Spacemaster		2002

Accessory Dwelling Units

Index # - File Name: 1.0022 - Single Family Dwellings Data\_Snohomish County.pdf

New	2 Story w/ 2 Car & Covered Porch		2002
New	Approved Basic #01-106258 BP	Plan: 2032-BL Two Story SFR - 1997 UBC	2002
New	Approved Basic #01-103531 BP	Plan: 1740/A Two Story SFR - 1997 UBC	2002
New	Approved Basic #01-101438 BP	Plan: 2409 C Two Story SFR - 1997 UBC	2002
New	Approved Basic #01-101438 BP	Plan: 2409 C Two Story SFR - 1997 UBC	2002
New	Approved Basic #01-106258 BP	Plan: 2032-BL Two Story SFR - 1997 UBC	2002
New	Approved Basic #01-101434 BP	Plan: 2042 Two Story SFR - 1997 UBC	2002
New	Approved Basic #01-101438 BP	Plan: 2409 C Two Story SFR - 1997 UBC	2002
New	Approved Basic #01-103531 BP	Plan: 1740/A Two Story SFR - 1997 UBC	2002
New	Approved Basic #01-101438 BP	Plan: 2409 C Two Story SFR - 1997 UBC	2002
New	Approved Basic #01-101434 BP	Plan: 2042 Two Story SFR - 1997 UBC	2002
New	Approved Basic #01-103531 BP	Plan: 1740/A Two Story SFR - 1997 UBC	2002
New	Approved Basic #01-106258 BP	Plan: 2032-BL Two Story SFR - 1997 UBC	2002
New	Approved Basic #01-101438 BP	Plan: 2409 C Two Story SFR - 1997 UBC	2002
New	Approved Basic #01-101434 BP	Plan: 2042 Two Story SFR - 1997 UBC	2002
New	Approved Basic #01-106258 BP	Plan: 2032-BL Two Story SFR - 1997 UBC	2002
New	Approved Basic #01-101438 BP	Plan: 2409 C Two Story SFR - 1997 UBC	2002
New	Approved Basic #01-106258 BP	Plan: 2032-BL Two Story SFR - 1997 UBC	2002
New	Approved Basic #01-101438 BP	Plan: 2409 C Two Story SFR - 1997 UBC	2002
New	Approved Basic #01-101434 BP	Plan: 2042 Two Story SFR - 1997 UBC	2002
New	Approved Basic #01-101435 BP	Plan: 2598 Two Story SFR - 1997 UBC	2002
New	Approved Basic #01-106258 BP	Plan: 2032-BL Two Story SFR - 1997 UBC	2002
New	Approved Basic #01-101438 BP	Plan: 2409 C Two Story SFR - 1997 UBC	2002
New	Approved Basic #01-101438 BP	Plan: 2409 C Two Story SFR - 1997 UBC	2002
New	Approved Basic #01-103531 BP	Plan: 1740/A Two Story SFR - 1997 UBC	2002
New	Approved Basic #01-106258 BP	Plan: 2032-BL Two Story SFR - 1997 UBC	2002
New	Approved Basic #01-106258 BP	Plan: 2032-BL Two Story SFR - 1997 UBC	2002
New	Approved Basic #01-111809 BP	Plan: 2722 (Revised 2656) Rambler Style SFR w/bonus	2002
New	2 story SFR w/ 3 car garage		2002
New	Approved Basic #98-150633BP	Plan: 44 er Two Story SFR - 1997	2002
New	Approved Basic #02-107029 BP	Plan: 2930 Two Story SFR - 1997 UBC	2002
New	Approved Basic #01-107342 BP	Plan: 2620 SSI Two Story SFR - 1997 UBC	2002
New	Approved Basic #98-150631BP	Plan: 47 er Two Story SFR - 1997	2002
New	Approved Basic #01-111603 BP	Bldrs Plan 2968 Two-story style SFR.....1997 UBC	2002
New	Approved Basic #01-111603 BP	Bldrs Plan 2968 Two-story style SFR.....1997 UBC	2002
New	Approved Basic #98-110516BP	Option Approved: Garage door design & entry change Two Str	2002
New	Approved Basic #01-107182 BP	Plan # SSI 2673 Two-story style SFR.....1997 UBC	2002
New	Approved Basic #01-101541BP	Plan: 2877 Two Story SFR - 1997 UBC	2002
New	2 story SFR with attached garage		2002
New	2-story w/garage		2002
New	2-story style SFR.....1997 UBC		2002
New	Two-story SFR		2002
New	2- Story SFR w/attached garage.		2002
New	Approved Basic #01-111494 BP	Bldr Plan SSI 2792 Two-story style SFR....1997 UBC	2002
New	Approved Basic #01-107342 BP	Plan: 2620 SSI Two Story SFR - 1997 UBC	2002
New	Approved Basic #02-109212 BP	Plan: 2797 Two Story SFR - 1997 UBC	2002
New	Approved Basic #01-107344 BP	Plan: TJI 2783 Two Story SFR - 1997 UBC	2002

Accessory Dwelling Units

Index # - File Name: 1.0022 - Single Family Dwellings Data\_Snohomish County.pdf

New	Approved Basic #01-101541BP	Plan: 2877	Two Story SFR - 1997 UBC	2002
New	Approved Basic #01-104632 BP	Plan: M 2980 A4FT-0	Two Story SFR - 1997 UBC	2002
New	Two-story SFR - 1997 UBC			2002
New	2-Story SFR w/attached garage.			2002
New	Two-story SFR with attached garage - 1997UBC			2002
New	3508 sf 2-story w/ 3 car garage			2002
New	2 story SFR with attached garage			2002
New	2-story SFR - 1997UBC			2002
New	Two-story SFR with attached garage -- 1997 UBC			2002
New	Rambler style SFR w/attached garage and media room			2002
New	Two-story SFR with attached garage - 1997 UBC			2002
New	Approved Basic #98-116510BP	Plan: 1610 C/2	Two-story SFR - 1997 UBC	2002
New	Approved Basic #99-104694BP	Plan: Georgetown	Two Story SFR - 1997 UBC	2002
New	Approved Basic #99-104574BP	Plan: Kirkwood	Rambler Style SFR - 1997 UBC	2002
New	Approved Basic #98-116510BP	Plan: 1610 C/2	Two-story SFR - 1997 UBC	2002
New	Approved Basic #99-116397 BP	Plan: Trisha - Mid-Entry	Mid-Entry Style SFR w/fir	2002
New	28 x 44 1995 Fleetwood			2002
New	28 X 40 Redmond 2002			2002
New	2 Story w/ semi-fished basement & 3 Car Garage			2002
New	Daylight basement style SFR w/attached garage.			2002
New	2-Story SFR, (no garage)			2002
New	Approved Basic #00-108299 BP	Plan: 1922/Covington	Two Story SF	2002
New	Approved Basic #02-106344-BP	Plan: 2838	Two Story SFR - 1997 UBC, 2001 V	2002
New	Two Story SFR - 1997 UBC	Plan: 2833		2002
New	Approved Basic #02-103480 BP	Plan: 2274	Rambler Style SFR - 1997 UBC	2002
New	Approved Basic #01-106939 BP	Plan: 3435	Two Story SFR.....1997 UBC	2002
New	2-Story SFR w/attached garages.			2002
New	Approved Basic #01-108228 BP	Plan: 2667	Two Story SFR - 1997 UBC	2002
New	Approved Basic #99-112673 BP	Plan: 3272	Two Story SFR - 1997 UBC	2002
New	Approved Basic #99-110535 BP	Plan: 2834	Two Story SFR - 1997 UBC 1st Opti	2002
New	Approved Basic #01-103904 BP	Plan: 2482 w/Basement	SFR w/semi-finished basen	2002
New	Approved Basic #01-107656 BP	Plan: 2472 w/bonus	Two Story SFR - 1997 UBC	2002
New	Approved Basic #02-103480 BP	Plan: 2370	Rambler Style SFR - 1997 UBC	2002
New	Two Story SFR - 1997 UBC	Plan: 3121		2002
New	Approved Basic #02-103480 BP	Plan: 2370	Rambler Style SFR - 1997 UBC	2002
New	2-Story SFR w/attached garage.			2002
New	Approved Basic #01-107656 BP	Plan: 2472 w/bonus	Two Story SFR - 1997 UBC	2002
New	2-Story SFR w/attached garage.			2002
New	Approved Basic #01-108228 BP	Plan No. 2667	Two Story SFR - 1997 UBC	2002
New	2 Story w/ 3 Car			2002
New	Two-story SFR with attached garage - 1997 UBC			2002
New	1 Story w/ deck			2002
New	2 story SFR w/attached 3 car garage			2002
New	Two Story SFR with Attached Garage			2002
New	2 story SFR w/ attached 3 car garage			2002
New	Two Story SFR - 1997 UBC			2002
New	2-Story SFR w/attached garage			2002

Accessory Dwelling Units

Index # - File Name: 1.0022 - Single Family Dwellings Data\_Snohomish County.pdf

New	Approved Basic #02-104447 BP	Plan: 5039 A	Two Story SFR - 1997 UBC	2002
New	SEE 01-110510. MOST INSPECTIONS DONE ON THAT PERMIT.		Two Story SFR - 1997 UBC	2002
New	Two-story SFR - 1997 UBC	Plan 127G		2002
New	Two Story SFR - 1997 UBC			2002
New	Approved Basic #02-104444 BP	Plan: 5039 M	Two Story SFR - 1997 UBC	2002
New	Two Story SFR - 1997 UBC	Plan: 936 D		2002
New	Two Story SFR - 1997 UBC	Plan: 127 G		2002
New	Approved Basic #02-104362 BP	Plan: 1939 D	Two Story SFR - 1997 UBC	2002
New	Approved Basic #02-104447 BP	Plan: 5039 A	Two Story SFR - 1997 UBC	2002
New	Two Story SFR - 1997 UBC	Plan: 2092-10		2002
New	Two-story SFR - 1997 UBC	Plan 4091B		2002
New	Two Story SFR - 1997 UBC	Plan: R 127 G		2002
New	Two Story SFR - 1997 UBC	Plan: 5039 M		2002
New	Two Story SFR - 1997 UBC	Plan: 127 G		2002
New	Two Story SFR - 1997 UBC	Plan: 1939 D		2002
New	Approved Basic #00-105848 BP	Plan: 936 A D	Two Story SFR - 1997 UBC	2002
New	Two Story SFR - 1997 UBC	Plan: 5039 A		2002
New	Two Story SFR - 1997 UBC	Plan: R 127 G		2002
New	Two Story SFR - 1997 UBC	Plan: 4045 A,M		2002
New	Two Story SFR - 1997 UBC	Plan: 5039		2002
New	Two Story SFR - 1997 UBC	Plan: 4145 M		2002
New	Approved Basic #00-105848 BP	Plan: 936 A D	Two Story SFR - 1997 UBC	2002
New	Two Story SFR - 1997 UBC	Plan: 936 D		2002
New	2053 sf rambler w/688 sf garage and 96 sf covered deck/porch - 1997 UBC			2002
New	2175 sf 2-stroy w/436 sf garage and 70 sf covered deck/porch			2002
New	Approved Basic #01-108132 BP	Plan No. 2621	Two Story SFR.....1997 UBC	2002
New	Approved Basic #02-106908 BP	Plan: 2230R/3	Rambler Style SFR - 1997 UBC	2002
New	Two Story SFR - 1997 UBC	Plan: 4145 A,M		2002
New	Two Story SFR - 1997 UBC	Plan: R 127 G		2002
New	Approved Basic #98-150628BP	Plan: 50 er	Two Story SFR - 1997 UBC	2002
New	Approved Basic #98-150633BP	Plan: 44 er	Two Story SFR - 1997	2002
New	Approved Basic #98-150633BP	Plan: 44 er	Two Story SFR - 1997	2002
New	Approved Basic #01-107342 BP	Plan: SSI 2620	Two Story SFR - 1997 UBC	2002
New	Two Story SFR - 1997 UBC	Plan: R 5039 A		2002
New	Two-story SFR w/attached 3 car garage			2002
New	2-story w/ garage,covered deck/porch and open patio			2002
New	28 x 60 - 1984 - Silvercrest Mobile Home.			2002
New	Two-story style SFR.....1997 UBC			2002
New	Approved Basic #02-102061 BP	Plan: 2010 Rambler	Rambler Style SFR - 1997 UBC	2002
New	Approved Basic #02-103658 BP	Plan 2500	Rambler Style SFR - 1997 UBC	2002
New	2010 s.f. rambler w/3 car garage			2002
New	2-Story SFR w/attached garage.			2002
New	Approved Basic #02-102061 BP	Plan: 2010 Rambler	Rambler Style SFR - 1997 UBC	2002
New	1280 sfr. w/1280 s.f. garage/shop below			2002
New	27x70, 2002 Palm Harbor			2002
New	Approved Basic #01-103739 BP	Plan: Colby	Two Story SFR - 1997 UBC	2002
New	2 story SFR w/ attached 2 car garage			2002



Accessory Dwelling Units

Index # - File Name: 1.0022 - Single Family Dwellings Data\_Snohomish County.pdf

New	1699sf SFR split-level entry - 1997 UBC		2002
New	2 story SFR with attached garage and covered porch		2002
New	Approved Basic #02-100274 BP	Plan: 1710 Two Story SFR - 1997 UBC	2002
New	Approved Basic #01-104133 BP	Plan: 1567 crawl Tri-Level SFR - 1997 UBC	2002
New	Approved Basic #02-100274 BP	Plan: 1710 Two Story SFR - 1997 UBC	2002
New	Approved Basic #01-106982 BP	Plan: 1705 crawl (revised) SFR w/finished lo	2002
New	Approved Basic #01-105743 BP	Plan: 1644 crawl Split Level SFR - 1997 UBC	2002
New	Approved Basic #01-105212 BP	Plan: 1538 Two Story SFR - 1997 UBC	2002
New	Approved Basic #01-104235 BP	Plan: 1573 Two Story SFR - 1997 UBC	2002
New	Approved Basic #01-111402 BP	Plan: 1680-revised engineering Two-Story style SFR..	2002
New	Approved Basic #01-106982 BP	Plan: 1705 crawl (revised) SFR w/finished lower floor -	2002
New	Approved Basic #01-105212 BP	Plan: 1538 Two Story SFR - 1997 UBC	2002
New	Approved Basic #01-104235 BP	Plan: 1573 Two Story SFR - 1997 UBC	2002
New	Approved Basic #01-111402 BP	Plan: 1680-revised engineering Two-Story style SFR..	2002
New	Approved Basic #02-100830 BP	Plan: 1686 Split Level SFR - 1997 UBC	2002
New	Approved Basic #01-105212 BP	Plan: 1538 Two Story SFR - 1997 UBC	2002
New	Approved Basic #01-111402 BP	Plan: 1680-revised engineering Two-Story style SFR..	2002
New	Approved Basic #01-105212 BP	Plan: 1538 Two Story SFR - 1997 UBC	2002
New	Approved Basic #02-100833 BP	Plan: 1573 revised Two Story SFR - 1997 UBC	2002
New	Approved Basic #01-111402 BP	Plan: 1680-revised engineering Two-Story style SFR..	2002
New	Approved Basic #01-106982 BP	Plan: 1705 crawl (revised) SFR w/finished lo	2002
New	Approved Basic #02-100830 BP	Plan: 1686 Split Level SFR - 1997 UBC	2002
New	Approved Basic #01-105212 BP	Plan: 1538 Two Story SFR - 1997 UBC	2002
New	Approved Basic #01-111402 BP	Plan: 1680-revised engineering Two-Story style SFR..	2002
New	Approved Basic #01-104235 BP	Plan: 1573 Two Story SFR - 1997 UBC	2002
New	Approved Basic #01-105212 BP	Plan: 1538 Two Story SFR - 1997 UBC	2002
New	Approved Basic #01-105212 BP	Plan: 1538 Two Story SFR - 1997 UBC	2002
New	Approved Basic #01-111402 BP	Plan: 1680-revised engineering Two-Story style SFR..	2002
New	Two Story SFR - 1997 UBC	Plan: 1710	2002
New	Approved Basic #02-100274 BP	Plan: 1710 Two Story SFR - 1997 UBC	2002
New	Approved Basic #01-111402 BP	Plan: 1680-revised engineering Two-Story style SFR..	2002
New	Approved Basic #02-100274 BP	Plan: 1710 Two Story SFR - 1997 UBC	2002
New	Approved Basic #02-100274 BP	Plan: 1710 Two Story SFR - 1997 UBC	2002
New	Approved Basic #01-111402 BP	Plan: 1680-revised engineering Two-Story style SFR..	2002
New	Approved Basic #01-106982 BP	Plan: 1705 crawl (revised) SFR w/finished lo	2002
New	Approved Basic #01-104133 BP	Plan: 1567 crawl Tri-Level SFR - 1997 UBC	2002
New	Approved Basic #02-100274 BP	Plan: 1710 Two Story SFR - 1997 UBC	2002
New	Approved Basic #02-100833 BP	Plan: 1573 revised Two Story SFR - 1997 UBC	2002
New	Approved Basic #01-105212 BP	Plan: 1538 Two Story SFR - 1997 UBC	2002
New	Approved Basic #01-111402 BP	Plan: 1680-revised engineering Two-Story style SFR..	2002
New	Approved Basic #02-100274 BP	Plan: 1710 Two Story SFR - 1997 UBC	2002
New	Approved Basic #01-104133 BP	Plan: 1567 crawl Tri-Level SFR - 1997 UBC	2002
New	Approved Basic #02-100274 BP	Plan: 1710 Two Story SFR - 1997 UBC	2002
New	Approved Basic #01-111402 BP	Plan: 1680-revised engineering Two-Story style SFR..	2002
New	Approved Basic #02-100274 BP	Plan: 1710 Two Story SFR - 1997 UBC	2002
New	Approved Basic #01-104133 BP	Plan: 1567 crawl Tri-Level SFR - 1997 UBC	2002
New	Approved Basic #02-100274 BP	Plan: 1710 Two Story SFR - 1997 UBC	2002

Accessory Dwelling Units

Index # - File Name: 1.0022 - Single Family Dwellings Data\_Snohomish County.pdf

New	Approved Basic #01-104133 BP	Plan: 1567 crawl Tri-Level SFR - 1997 UBC	2002
New	Approved Basic #02-100274 BP	Plan: 1710 Two Story SFR - 1997 UBC	2002
New	2-story style SFR...1997 UBC	Bldrs Plan: 2452 A	2002
New	Approved Basic #02-103204 BP	Plan: Balmoral B Two Story SFR - 1997 UBC	2002
New	Approved Basic #02-100339 BP	Plan: Windsor Two Story SFR - 1997 UBC	2002
New	2-story style SFR...1997 UBC	Bldrs Plan: 2565 B	2002
New	2-story style SFR...1997 UBC	Bldrs Plan: 2155-3	2002
New	Approved Basic #02-104945 BP	Plan: Windsor A/2741-A (revised) Two Story SFF	2002
New	Approved Basic #02-103204 BP	Plan: Balmoral B Two Story SFR - 1997 UBC	2002
New	Approved Basic #02-104945 BP	Plan: Windsor A/2741-A (revised) Two Story SFF	2002
New	Approved Basic #02-103207 BP	Plan: Ashbury A Two Story SFR - 1997 UBC	2002
New	Approved Basic #02-103204 BP	Plan: Balmoral B Two Story SFR - 1997 UBC	2002
New	Approved Basic #02-103204 BP	Plan: Balmoral B Two Story SFR - 1997 UBC	2002
New	Two Story SFR - 1997 UBC	Plan: Richmond - A	2002
New	Approved Basic #02-103207 BP	Plan: Ashbury A Two Story SFR - 1997 UBC	2002
New	Approved Basic #02-103203 BP	Plan: Canterbury A Two Story SFR - 1997 UBC	2002
New	Approved Basic #02-103207 BP	Plan: Ashbury A Two Story SFR - 1997 UBC	2002
New	Approved Basic #02-103206 BP	Plan: Westcott A Two Story SFR - 1997 UBC	2002
New	Approved Basic #02-103204 BP	Plan: Balmoral B Two Story SFR - 1997 UBC	2002
New	Approved Basic #01-106982 BP	Plan: 1705 crawl (revised) SFR w/finished lo	2002
New	Approved Basic #01-105212 BP	Plan: 1538 Two Story SFR - 1997 UBC	2002
New	Approved Basic #01-111402 BP	Plan: 1680-revised engineering Two-Story style SFR..	2002
New	Approved Basic #01-106982 BP	Plan: 1705 crawl (revised) SFR w/finished lo	2002
New	Approved Basic #01-105212 BP	Plan: 1538 Two Story SFR - 1997 UBC	2002
New	Approved Basic #01-106982 BP	Plan: 1705 crawl (revised) SFR w/finished lo	2002
New	Approved Basic #02-100833 BP	Plan: 1573 revised Two Story SFR - 1997 UBC	2002
New	Approved Basic #01-105212 BP	Plan: 1538 Two Story SFR - 1997 UBC	2002
New	Approved Basic #01-106982 BP	Plan: 1705 crawl (revised) SFR w/finished lo	2002
New	Approved Basic #01-111402 BP	Plan: 1680-revised engineering Two-Story style SFR..	2002
New	Approved Basic #02-100412 BP	Plan: 2155-3 Two Story SFR - 1997 UBC	2002
New	Approved Basic #02-100412 BP	Plan: 2155-3 Two Story SFR - 1997 UBC	2002
New	Approved Basic 02 105632 BP	Plan: Richmond Two-story SFR - 1997 UBC	2002
New	Two Story SFR - 1997 UBC	Plan: Windsor - C	2002
New	Two Story SFR - 1997 UBC	Plan: Ashbury - B	2002
New	Approved Basic #02-103203 BP	Plan: Canterbury A Two Story SFR - 1997 UBC	2002
New	Approved Basic #02-103204 BP	Plan: Balmoral B Two Story SFR - 1997 UBC	2002
New	Approved Basic #02-100339 BP	Plan: Windsor Two Story SFR - 1997 UBC	2002
New	Approved Basic #02-100337 BP	Plan: Westcott Two Story SFR - 1997 UBC	2002
New	Approved Basic #02-103204 BP	Plan: Balmoral B Two Story SFR - 1997 UBC	2002
New	Approved Basic #02-100339 BP	Plan: Windsor Two Story SFR - 1997 UBC	2002
New	Approved Basic #02-100337 BP	Plan: Westcott Two Story SFR - 1997 UBC	2002
New	Approved Basic #02-103203 BP	Plan: Canterbury A Two Story SFR - 1997 UBC	2002
New	Approved Basic #02-103201 BP	Plan: Manchester A Two Story SFR - 1997 UBC	2002
New	Approved Basic #02-103642 BP	Plan: Balmoral-A Two-story SFR - 1997	2002
New	Approved Basic #02-104945 BP	Plan: Windsor A/2741-A (revised) Two Story SFF	2002
New	Approved Basic #02-103204 BP	Plan: Balmoral B Two Story SFR - 1997 UBC	2002
New	Approved Basic #02-103207 BP	Plan: Ashbury A Two Story SFR - 1997 UBC	2002

Accessory Dwelling Units

Index # - File Name: 1.0022 - Single Family Dwellings Data\_Snohomish County.pdf

New	Approved Basic #02-103204 BP	Plan: Balmoral B Two Story SFR - 1997 UBC	2002
New	Approved Basic #02-100337 BP	Plan: Westcott Two Story SFR - 1997 UBC	2002
New	Approved Basic #02-100412 BP	Plan: Ashbury Two Story SFR - 1997 UBC	2002
New	Approved Basic #02-104945 BP	Plan: Windsor A/2741-A (revised) Two Story SFF	2002
New	Approved Basic #02-100412 BP	Plan: Ashbury Two Story SFR - 1997 UBC	2002
New	Approved Basic #02-100413 BP	Plan: Balmoral Two Story SFR - 1997 UBC	2002
New	Approved Basic #02-100339 BP	Plan: Windsor Two Story SFR - 1997 UBC	2002
New	Approved Basic #02-100413 BP	Plan: Balmoral Two Story SFR - 1997 UBC	2002
New	Approved Basic #02-100412 BP	Plan: Ashbury Two Story SFR - 1997 UBC	2002
New	Approved Basic #02-100339 BP	Plan: Windsor Two Story SFR - 1997 UBC	2002
New	Approved Basic #02-100412-BP	Plan: 2155-3 Two Story SFR - 1997 UBC	2002
New	2-story style SFR...1997 UBC	Bldrs Plan: 2741 A	2002
New	Approved Basic #02-100413 BP	Plan 2565 Two-story SFR w/attached garage	2002
New	2-story style SFR...1997 UBC	Bldrs Plan: 2383 A	2002
New	Approved Basic #02-100339 BP	Plan: Windsor Two Story SFR - 1997 UBC	2002
New	Approved Basic #02-100413 BP	Plan: Balmoral Two Story SFR - 1997 UBC	2002
New	Approved Basic #02-100413 BP	Plan: Balmoral Two Story SFR - 1997 UBC	2002
New	2-story style SFR...1997 UBC	Bldrs Plan: 2373 A	2002
New	Approved Basic #02-100339 BP	Plan: Windsor Two Story SFR - 1997 UBC	2002
New	Approved Basic #02-100413 BP	Plan: Balmoral Two Story SFR - 1997 UBC	2002
New	Approved Basic #02-105632 BP	Plan: Richmond Two-story SFR - 1997 UBC	2002
New	Two Story SFR - 1997 UBC	Plan: Balmoral - A	2002
New	Approved Basic #02-103201 BP	Plan: Manchester A Two Story SFR - 1997 UBC	2002
New	Approved Basic #02-103204 BP	Plan: Balmoral B Two Story SFR - 1997 UBC	2002
New	Approved Basic #02-103638 BP	Plan: Ashbury-B Two-story SFR - 1997 UBC	2002
New	Approved Basic #01-104235 BP	Plan: 1573 Two Story SFR - 1997 UBC	2002
New	Two-story SFR - 1997 UBC		2002
New	One-story SFR - 1997 UBC		2002
New	1605sf one-story SFR - 1997 UBC		2002
New	2 Story w/ 2 Car		2002
New	One-story SFR -1997UBC		2002
New	Approved Basic #02-100821 BP	Plan: Jessica II Rambler Style SFR - 1997 UBC	2002
New	Approved Basic #01-106641 BP	Plan: KayDee Rambler Style SFR - 1997 UBC	2002
New	Approved Basic #02-100759-BP	Plan: Madison Rambler style SFR - 1997 UBC	2002
New	Approved Basic #01-106641 BP	Plan: KayDee Rambler Style SFR - 1997 UBC	2002
New	2 Story w/ 2 Car		2002
New	Approved Basic #00-108051 BP	Plan: #1818/Getchell Rambler style SFR 1997 UBC	2002
New	Approved Basic #01-113747 BP	Plan: 2024 Two Story SFR - 1997 UBC	2002
New	Approved Basic #00-108051 BP	Plan: #1818/Getchell Rambler style SFR 1997 UBC	2002
New	Approved Basic #00-106822 BP	Bldrs Plan: Kayak Two Story SFR.....1997 UBC	2002
New	Rambler Style SFR - 1997 UBC	Plan: Tate II	2002
New	Approved Basic #02-109089 BP	Plan: 1420 Rambler Style SFR - 1997 UBC	2002
New	Approved Basic 00 104401 BP	Builders Plan 6410 Two-story SFR w/attached ga	2002
New	2 Story w/ Daylight Basement, 3 Car Garage		2002
New	Two Story SFR - 1997 UBC	Plan: Summit 2	2002
New	Approved Basic #02-100818 BP	Plan: M1759A2F-ODB Two story SFR w/finished baserr	2002
New	2-story style SFR - 1997 UBC		2002

Accessory Dwelling Units

Index # - File Name: 1.0022 - Single Family Dwellings Data\_Snohomish County.pdf

New	Approved Basic #02-100818 BP	Plan: M1759A2F-ODB	Two story SFR w/finished basem	2002
New	Daylight basement style SFR w/attached garage & unfinished basement.			2002
New	2 Story SFR w/ deck			2002
New	Approved Basic #01-103744 BP	Plan: Willow	Two Style SFR - 1997 UBC	2002
New	Approved Basic #01-103740 BP	Plan: Aspen	Rambler Style SFR - 1997 UBC	2002
New	Approved Basic #01-103742 BP	Plan: Patrick	Rambler Style SFR - 1997 UBC	2002
New	Two Story SFR - 1997 UBC	Plan: Shiloh 2		2002
New	Approved Basic #01-103737 BP	Plan: Topeka	Two Story SFR - 1997 UBC	2002
New	Approved Basic #01-103739 BP	Plan: Colby	Two Story SFR - 1997 UBC	2002
New	Approved Basic #01-103743 BP	Plan: Everett	Two Style SFR - 1997 UBC	2002
New	Approved Basic #01-103744 BP	Plan: Willow	Two Style SFR - 1997 UBC	2002
New	1 story SFR w/ attached garage			2002
New	2 story SFR w/ attached garage			2002
New	1335 2-story w/680 sf semi basement, 440 sf garage, 114 sf covered deck/porch and 100 sf ope			2002
New	Approved Basic #01-103737 BP	Plan: Topeka	Two Story SFR - 1997 UBC	2002
New	2 Story w/ 2 Car			2002
New	2 story SFR w/ attached garage			2002
New	Rambler Style SFR - 1997 UBC	Plan: Tate II		2002
New	Approved Basic #01-103744 BP	Plan: Willow	Two Style SFR - 1997 UBC	2002
New	Approved Basic #01-103742 BP	Plan: Patrick	Rambler Style SFR - 1997 UBC	2002
New	Approved Basic #01-103740 BP	Plan: Aspen	Rambler Style SFR - 1997 UBC	2002
New	Approved Basic #01-103737 BP	Plan: Topeka	Two Story SFR - 1997 UBC	2002
New	Approved Basic #01-103740 BP	Plan: Aspen	Rambler Style SFR - 1997 UBC	2002
New	Approved Basic #01-103740 BP	Plan: Aspen	Rambler Style SFR - 1997 UBC	2002
New	One-story SFR			2002
New	Rambler w/ 2 Car			2002
New	Approved Basic #01-103737 BP	Plan: Topeka	Two Story SFR - 1997 UBC	2002
New	Approved Basic #01-103743 BP	Plan: Everett	Two Style SFR - 1997 UBC	2002
New	Approved Basic #01-103742 BP	Plan: Patrick	Rambler Style SFR - 1997 UBC	2002
New	Split Entry style SFR with basement garage -1997-UBC			2002
New	Approved Basic 02 105980 BP		Builders Plan: 9114 One-story SFF	2002
New	Approved Basic #02-104119 BP	Plan: 0124 - revised	Two Story SFR w/finished bas	2002
New	Approved Basic #02-100818 BP	Plan: M1759A2F-ODB	Two story SFR w/finished basem	2002
New	Approved Basic #02-101429-BP	Plan: 0124	Two Story SFR w/finished basement -	2002
New	Two Story SFR w/finished basement - 1997 UBC			2002
New	Approved Basic #00-100867 BP		Plan: 2220 Mid Entry SFR - 1997 UBC	2002
New	Approved Basic 99105003 BP		Builders Plan 9410-A Two-story SFR w/	2002
New	Approved Basic #01-112898 BP	Bldrs Plan 9905	Mid-Entry SFR - 1997 UBC	2002
New	Approved Basic #00-100867 BP		Plan: 2220 Mid Entry SFR - 1997 UBC	2002
New	Approved Basic #02-100818 BP	Plan: M1759A2F-ODB	Two story SFR w/finished basem	2002
New	Approved Basic #02-100818 BP	Plan: M1759A2F-ODB	Two story SFR w/finished basem	2002
New	Approved Basic #02-100818 BP	Plan: M1759A2F-ODB	Two story SFR w/finished basem	2002
New	Approved Basic #01-103672 BP	Plan: #2002	Two Story SFR - 1997 UBC Opti	2002
New	Two-story SFR with 2/3 car option & daylight basement		Builder s Plan 2284 daylight	2002
New	Two-story SFR with finished basement		Builder s Plan 2342 Basement	2002
New	Approved Basic #98-108806BP		Plan 1936 Split 1174 sf SFR w/semi-fini	2002
New	Approved Basic #98-108803BP		Plan 1771 Cal 1158 sf SFR w/semi-finished	2002

Accessory Dwelling Units

Index # - File Name: 1.0022 - Single Family Dwellings Data\_Snohomish County.pdf

New	Approved Basic #02-104796 BP	Plan: 1932 B (concrete) SFR w/unfinished lower floor -	2002
New	Approved Basic #98-108803BP	Plan 1771 Cal 1158 sf SFR w/semi-finished	2002
New	Approved Basic #98-108806BP	Plan 1936 Split 1174 sf SFR w/semi-fini	2002
New	Approved Basic #01-113099 BP	Plan 2193 Split level SFR - 1997 UBC	2002
New	Approved Basic #01-113722 BP	Plan: 1130 Two Story SFR - 1997 UBC	2002
New	Approved Basic #01-113722 BP	Plan: 1130 Two Story SFR - 1997 UBC	2002
New	Approved Basic #01-113099 BP	Plan 2193 Split level SFR - 1997 UBC	2002
New	Approved Basic #01-113099 BP	Plan 2193 Split level SFR - 1997 UBC	2002
New	Approved Basic #98-108806BP	Plan 1936 Split 1174 sf SFR w/semi-fini	2002
New	Approved Basic #98-108803BP	Plan 1771 Cal 1158 sf SFR w/semi-finished	2002
New	Approved Basic #98-108806BP	Plan 1936 Split 1174 sf SFR w/semi-fini	2002
New	Approved Basic #98-108803BP	Plan 1771 Cal 1158 sf SFR w/semi-finished	2002
New	Approved Basic #02-104529 BP	Plan: 1932 A SFR w/unfinished lower floor - 199	2002
New	Approved Basic #98-108806BP	Plan 1936 Split 1174 sf SFR w/semi-fini	2002
New	Approved Basic #98-108803BP	Plan 1771 Cal 1158 sf SFR w/semi-finished	2002
New	Approved Basic #98-108806BP	Plan 1936 Split 1174 sf SFR w/semi-fini	2002
New	Approved Basic #98-108803BP	Plan 1771 Cal 1158 sf SFR w/semi-finished	2002
New	Approved Basic #98-108806BP	Plan 1936 Split 1174 sf SFR w/semi-fini	2002
New	Approved Basic #01-113099 BP	Plan 2193 Split level SFR - 1997 UBC	2002
New	Approved Basic #98-108806BP	Plan 1936 Split 1174 sf SFR w/semi-fini	2002
New	Approved Basic #01-113099 BP	Plan 2193 Split level SFR - 1997 UBC	2002
New	Approved Basic #98-108803BP	Plan 1771 Cal 1158 sf SFR w/semi-finished	2002
New	Approved Basic #98-108806BP	Plan 1936 Split 1174 sf SFR w/semi-fini	2002
New	Approved Basic #98-108803BP	Plan 1771 Cal 1158 sf SFR w/semi-finished	2002
New	Approved Basic #98-108806BP	Plan 1936 Split 1174 sf SFR w/semi-fini	2002
New	Approved Basic #98-108803BP	Plan 1771 Cal 1158 sf SFR w/semi-finished	2002
New	Approved Basic #98-108806BP	Plan 1936 Split 1174 sf SFR w/semi-fini	2002
New	Approved Basic #02-104796 BP	Plan: 1932 B (concrete) SFR w/unfinished lower floor	2002
New	Approved Basic #98-108803BP	Plan 1771 Cal 1158 sf SFR w/semi-finished	2002
New	Approved Basic #98-108803BP	Plan 1771 Cal 1158 sf SFR w/semi-finished	2002
New	Approved Basic #98-108806BP	Plan 1936 Split 1174 sf SFR w/semi-fini	2002
New	Approved Basic #98-108803BP	Plan 1771 Cal 1158 sf SFR w/semi-finished	2002
New	Approved Basic #01-113099 BP	Plan 2193 Split level SFR - 1997 UBC	2002
New	Approved Basic #98-108806BP	Plan 1936 Split 1174 sf SFR w/semi-fini	2002
New	Approved Basic #98-108806BP	Plan 1936 Split 1174 sf SFR w/semi-fini	2002
New	Approved Basic #98-108806BP	Plan 1936 Split 1174 sf SFR w/semi-fini	2002
New	Approved Basic #98-108803BP	Plan 1771 Cal 1158 sf SFR w/semi-finished	2002
New	SFR w/unfinished lower floor - 1997 UBC	Plan: 1932 A (wood)	2002
New	Approved Basic #98-108806BP	Plan 1936 Split 1174 sf SFR w/semi-fini	2002
New	Approved Basic #98-108803BP	Plan 1750 Cal 1174 sf SFR w/semi-finished	2002
New	Approved Basic #01-113099 BP	Plan 2193 Split level SFR - 1997 UBC	2002
New	Approved Basic #98-108806BP	Plan 1936 Split 1174 sf SFR w/semi-fini	2002
New	Approved Basic #98-108803BP	Plan 1750 Cal 1174 sf SFR w/semi-finished	2002
New	Approved Basic #98-108806BP	Plan 1936 Split 1174 sf SFR w/semi-fini	2002
New	Approved Basic #98-108806BP	Plan 1936 Split 1174 sf SFR w/semi-fini	2002
New	SFR w/unfinished lower floor - 1997 UBC	Plan: 1932 B (concrete)	2002
New	Approved Basic #98-108803BP	Plan 1750 Cal 1174 sf SFR w/semi-finished	2002

Accessory Dwelling Units

Index # - File Name: 1.0022 - Single Family Dwellings Data\_Snohomish County.pdf

New	Approved Basic #98-108806BP	Plan 1936 Split 1174 sf SFR w/semi-fini	2002
New	Approved Basic #98-108803BP	Plan 1750 Cal 1174 sf SFR w/semi-finished	2002
New	Approved Basic #01-113099 BP	Plan 2193 Split level SFR - 1997 UBC	2002
New	Approved Basic #98-108803BP	Plan 1771 Cal 1158 sf SFR w/semi-finished	2002
New	Approved Basic #98-108806BP	Plan 1936 Split 1174 sf SFR w/semi-fini	2002
New	Approved Basic #01-113722 BP	Plan: 1130 Two Story SFR - 1997 UBC	2002
New	Approved Basic #01-112836 BP	Plan: 1221 Two Story SFR - 1997 UBC	2002
New	Approved Basic #01-113722 BP	Plan: 1130 Two Story SFR - 1997 UBC	2002
New	Approved Basic #01-112836 BP	Plan: 1221 Two Story SFR - 1997 UBC	2002
New	Approved Basic #01-113722 BP	Plan: 1130 Two Story SFR - 1997 UBC	2002
New	Approved Basic #01-112836 BP	Plan: 1221 Two Story SFR - 1997 UBC	2002
New	Approved Basic #01-113722 BP	Plan: 1130 Two Story SFR - 1997 UBC	2002
New	Approved Basic #01-112836 BP	Plan: 1221 Two Story SFR - 1997 UBC	2002
New	Approved Basic #01-113722 BP	Plan: 1130 Two Story SFR - 1997 UBC	2002
New	Approved Basic #01-112836 BP	Plan: 1221 Two Story SFR - 1997 UBC	2002
New	Approved Basic #01-113722 BP	Plan: 1130 Two Story SFR - 1997 UBC	2002
New	Approved Basic #01-112836 BP	Plan: 1221 Two Story SFR - 1997 UBC	2002
New	Approved Basic #01-113722 BP	Plan: 1130 Two Story SFR - 1997 UBCC	2002
New	Approved Basic #01-113099 BP	Plan 2193 Split level SFR - 1997 UBC	2002
New	Approved Basic #98-108806BP	Plan 1936 Split 1174 sf SFR w/semi-fini	2002
New	Approved Basic #01-113099 BP	Plan 2193 Split level SFR - 1997 UBC	2002
New	Approved Basic #98-108803BP	Plan 1750 Cal 1174 sf SFR w/semi-finished	2002
New	Rambler w/690 sf garage and 312 sf covered deck/porch		2002
New	2-story w/covered porch		2002
New	2-story w/ attached garage		2002
New	2 Story SFR w/ 3 car		2002
New	Approved Basic #98-108803BP	Plan 1771 Cal 1158 sf SFR w/semi-finished	2002
New	2700 sf 2-stroy w/garage, covered deck/porch and open deck		2002
New	Two-story SFR with Attached Accessory Apartment	New plans and calculations submitted 10/0	2002
New	2 story SFR with attached garage		2002
New	One-story SFR		2002
New	2952 sf 2-story w/576 sf garage and 296 sf covered deck/porch		2002
New	Approved Basic #02 100439 BP	SFR w/finshed basement - 1997 UBC	2002
New	Two-story SFR w/attached garage		2002
New	One-story SFR w/attached garage		2002
New	Two Story SFR with Attached Garage		2002
New	Approved Basic #01-112734 BP	Plan: 2164 Hip Two Story SFR - 1997 UBC	2002
New	Approved Basic #01-112384 BP	Plan: 1253 slab (Elev B) Rambler Style SFR - 199	2002
New	Approved Basic #00-103621 BP	Plan: 1199 (slab) Rambler Style SFR - 1997 UB	2002
New	Approved Basic #00-103622 BP	Plan: 1399 (slab) Rambler Style SFR - 1997 UBC	2002
New	Approved Basic #00-103622 BP	Plan: 1399 (slab) Rambler Style SFR - 1997 UBC	2002
New	Approved Basic #00-103622 BP	Plan: 1399 (slab) Rambler Style SFR - 1997 UBC	2002
New	Approved Basic #01-112384 BP	Plan: 1253 slab (Elev B) Rambler Style SFR - 199	2002
New	Approved Basic #00-103621 BP	Plan: 1199 (slab) Rambler Style SFR - 1997 UB	2002
New	Approved Basic #01-112384 BP	Plan: 1253 slab (Elev B) Rambler Style SFR - 199	2002
New	Approved Basic #00-103622 BP	Plan: 1399 (slab) Rambler Style SFR - 1997 UBC	2002
New	Approved Basic #01-112384 BP	Plan: 1253 slab (Elev B) Rambler Style SFR - 199	2002

Accessory Dwelling Units

Index # - File Name: 1.0022 - Single Family Dwellings Data\_Snohomish County.pdf

New	Approved Basic #00-103621 BP	Plan: 1199 (slab) Rambler Style SFR - 1997 UB	2002
New	Approved Basic #00-103622 BP	Plan: 1399 (slab) Rambler Style SFR - 1997 UBC	2002
New	Approved Basic #01-112384 BP	Plan: 1253 slab (Elev B) Rambler Style SFR - 199	2002
New	Approved Basic #00-103622 BP	Plan: 1399 (slab) Rambler Style SFR - 1997 UBC	2002
New	Approved Basic #00-103622 BP	Plan: 1399 (slab) Rambler Style SFR - 1997 UBC	2002
New	Approved Basic #00-103622 BP	Plan: 1399 (slab) Rambler Style SFR - 1997 UBC	2002
New	Approved Basic #00-103622 BP	Plan: 1399 (slab) Rambler Style SFR - 1997 UBC	2002
New	Approved Basic #00-103621 BP	Plan: 1199 (slab) Rambler Style SFR - 1997 UB	2002
New	Approved Basic #00-103622 BP	Plan: 1399 (slab) Rambler Style SFR - 1997 UBC	2002
New	Approved Basic #00-103621 BP	Plan: 1199 (slab) Rambler Style SFR - 1997 UB	2002
New	Approved Basic #00-103622 BP	Plan: 1399 (slab) Rambler Style SFR - 1997 UBC	2002
New	Approved Basic #01-112384 BP	Plan: 1253 slab (Elev B) Rambler Style SFR - 199	2002
New	Approved Basic #00-103621 BP	Plan: 1199 (slab) Rambler Style SFR - 1997 UB	2002
New	Approved Basic #99-103817BP	Plan: 1200 (Floor Framing Change) Rambler Style SFR -	2002
New	Approved Basic #00-103622 BP	Plan: 1399 (slab) Rambler Style SFR - 1997 UBC	2002
New	Approved Basic #00-103621 BP	Plan: 1199 (slab) Rambler Style SFR - 1997 UB	2002
New	Approved Basic #01-112384 BP	Plan: 1253 slab (Elev B) Rambler Style SFR - 199	2002
New	*****STOP WORK PLACED 3-1-02 by GS***** - erosion control measures failing - Char		2002
New	Two Story SFR with Attached Garage		2002
New	Approved Basic #02-101388 BP	Plan: 2189 (Ruston) Two Story SFR - 1997 UBC	2002
New	Approved Basic #02-101372 BP	Plan: 22107A Ruston Two Story SFR - 1997 UBC	2002
New	Approved Basic #00-103621 BP	Plan: 1199 (slab) Rambler Style SFR - 1997 UB	2002
New	Approved Basic #00-103621 BP	Plan: 1199 (slab) Rambler Style SFR - 1997 UB	2002
New	Approved Basic #02-101372 BP	Plan: 22107A Ruston Two Story SFR - 1997 UBC	2002
New	Two Story SFR - 1997 UBC		2002
New	*****STOP WORK PLACED 3-1-02 by GS***** - erosion control measures failing - Char		2002
New	Approved Basic #02-101388 BP	Plan: 2189 (Ruston) Two Story SFR - 1997 UBC	2002
New	Approved Basic #00-103622 BP	Plan: 1399 (slab) Rambler Style SFR - 1997 UBC	2002
New	Approved Basic #01-112384 BP	Plan: 1253 slab (Elev B) Rambler Style SFR - 199	2002
New	Approved Basic #00-103622 BP	Plan: 1399 (slab) Rambler Style SFR - 1997 UBC	2002
New	Approved Basic #00-103621 BP	Plan: 1199 (slab) Rambler Style SFR - 1997 UB	2002
New	Approved Basic #00-103622 BP	Plan: 1399 (slab) Rambler Style SFR - 1997 UBC	2002
New	Approved Basic #00-103621 BP	Plan: 1199 (slab) Rambler Style SFR - 1997 UB	2002
New	Approved Basic #00-103622 BP	Plan: 1399 (slab) Rambler Style SFR - 1997 UBC	2002
New	Approved Basic #00-103621 BP	Plan: 1199 (slab) Rambler Style SFR - 1997 UB	2002
New	Approved Basic #01-112384 BP	Plan: 1253 slab (Elev B) Rambler Style SFR - 199	2002
New	Approved Basic #00-103622 BP	Plan: 1399 (slab) Rambler Style SFR - 1997 UBC	2002
New	Approved Basic #01-112384 BP	Plan: 1253 slab (Elev B) Rambler Style SFR - 199	2002
New	Approved Basic #00-103621 BP	Plan: 1199 (slab) Rambler Style SFR - 1997 UB	2002
New	Approved Basic #00-103622 BP	Plan: 1399 (slab) Rambler Style SFR - 1997 UBC	2002
New	Approved Basic #01-112384 BP	Plan: 1253 slab (Elev B) Rambler Style SFR - 199	2002
New	Approved Basic #00-103622 BP	Plan: 1399 (slab) Rambler Style SFR - 1997 UBC	2002
New	Approved Basic #00-103621 BP	Plan: 1199 (slab) Rambler Style SFR - 1997 UB	2002
New	Approved Basic #00-103621 BP	Plan: 1199 (slab) Rambler Style SFR - 1997 UB	2002
New	Approved Basic #00-103622 BP	Plan: 1399 (slab) Rambler Style SFR - 1997 UBC	2002
New	Approved Basic #01-112384 BP	Plan: 1253 slab (Elev B) Rambler Style SFR - 199	2002
New	Approved Basic #00-103622 BP	Plan: 1399 (slab) Rambler Style SFR - 1997 UBC	2002

Accessory Dwelling Units

Index # - File Name: 1.0022 - Single Family Dwellings Data\_Snohomish County.pdf

New	Approved Basic #01-112384 BP	Plan: 1253 slab (Elev B) Rambler Style SFR - 199	2002
New	Approved Basic #00-103622 BP	Plan: 1399 (slab) Rambler Style SFR - 1997 UBC	2002
New	Approved Basic #00-103621 BP	Plan: 1199 (slab) Rambler Style SFR - 1997 UB	2002
New	Approved Basic #01-112384 BP	Plan: 1253 slab (Elev B) Rambler Style SFR - 199	2002
New	Approved Basic #00-103621 BP	Plan: 1199 (slab) Rambler Style SFR - 1997 UBC	2002
New	Approved Basic #99-103817BP	Plan: 1200 (Floor Framing Change) Rambler Style SFR -	2002
New	Approved Basic #99-103817BP	Plan: 1200 (Floor Framing Change) Rambler Style SFR -	2002
New	Approved Basic #01-112384 BP	Plan: 1253 slab (Elev B) Rambler Style SFR - 199	2002
New	Approved Basic #00-103622 BP	Plan: 1399 (slab) Rambler Style SFR - 1997 UBC	2002
New	Approved Basic #01-112384 BP	Plan: 1253 slab (Elev B) Rambler Style SFR - 199	2002
New	Approved Basic #00-103621 BP	Plan: 1199 (slab) Rambler Style SFR - 1997 UB	2002
New	Approved Basic #01-112384 BP	Plan: 1253 slab (Elev B) Rambler Style SFR - 199	2002
New	Approved Basic #00-103621 BP	Plan: 1199 (slab) Rambler Style SFR - 1997 UB	2002
New	Approved Basic #01-112384 BP	Plan: 1253 slab (Elev B) Rambler Style SFR - 199	2002
New	Approved Basic #00-103621 BP	Plan: 1199 (slab) Rambler Style SFR - 1997 UB	2002
New	Approved Basic #00-103622 BP	Plan: 1399 (slab) Rambler Style SFR - 1997 UBC	2002
New	Approved Basic #00-103621 BP	Plan: 1199 (slab) Rambler Style SFR - 1997 UB	2002
New	Approved Basic #01-112384 BP	Plan: 1253 slab (Elev B) Rambler Style SFR - 199	2002
New	Approved Basic #00-103621 BP	Plan: 1199 (slab) Rambler Style SFR - 1997 UB	2002
New	Approved Basic #01-112384 BP	Plan: 1253 slab (Elev B) Rambler Style SFR - 199	2002
New	Approved Basic #00-103621 BP	Plan: 1199 (slab) Rambler Style SFR - 1997 UB	2002
New	Approved Basic #01-112384 BP	Plan: 1253 slab (Elev B) Rambler Style SFR - 199	2002
New	Approved Basic #00-103622 BP	Plan: 1399 (slab) Rambler Style SFR - 1997 UBC	2002
New	Approved Basic #00-103622 BP	Plan: 1399 (slab) Rambler Style SFR - 1997 UBC	2002
New	Approved Basic #00-103621 BP	Plan: 1199 (slab) Rambler Style SFR - 1997 UB	2002
New	Approved Basic #00-103622 BP	Plan: 1399 (slab) Rambler Style SFR - 1997 UBC	2002
New	Approved Basic #00-103621 BP	Plan: 1199 (slab) Rambler Style SFR - 1997 UB	2002
New	Approved Basic #00-103621 BP	Plan: 1199 (slab) Rambler Style SFR - 1997 UB	2002
New	Approved Basic #00-103622 BP	Plan: 1399 (slab) Rambler Style SFR - 1997 UBC	2002
New	Approved Basic #01-112384 BP	Plan: 1253 slab (Elev B) Rambler Style SFR - 199	2002
New	Approved Basic #00-103621 BP	Plan: 1199 (slab) Rambler Style SFR - 1997 UB	2002
New	Approved Basic 99-115184 BP	Plan: 1399 Rambler Style SFR - 1997 UBC	2002
New	Approved Basic 99-115181BP	Plan: 1199 Rambler Style SFR - 1997 U	2002
New	Approved Basic 99-115184 BP	Plan: 1399 Rambler Style SFR - 1997 UBC	2002
New	Approved Basic 99-115184 BP	Plan: 1399 Rambler Style SFR - 1997 UBC	2002
New	Approved Basic #01-112384 BP	Plan: 1253 slab (Elev B) Rambler Style SFR - 199	2002
New	Approved Basic #00-103621 BP	Plan: 1199 (slab) Rambler Style SFR - 1997 UB	2002
New	Approved Basic #01-112384 BP	Plan: 1253 slab (Elev B) Rambler Style SFR - 199	2002
New	Approved Basic #01-112736 BP	Plan: 2288 Hip Two Story SFR - 1997 UBC	2002
New	Approved Basic #98-110563BP	Plan 2146 Two Story SFR - 1997 UBC	2002
New	Approved Basic #98-110563BP	Plan 2146 Two Story SFR - 1997 UBC	2002
New	Approved Basic #02-101373 BP	Pan: 2164A Oberlin Two Story SFR - 1997 UBC	2002
New	Approved Basic #02-101388 BP	Plan: 2189 (Ruston) Two Story SFR - 1997 UBC	2002
New	Approved Basic #02-101372 BP	Plan: 22107A Ruston Two Story SFR - 1997 UBC	2002
New	Approved Basic #01-112732 BP	Plan: 1920 Gable Two Story SFR - 1997 UBC	2002
New	Approved Basic #01-112737 BP	Plan: 2170 Hip Two Story SFR - 1997 UBC	2002
New	Approved Basic #02-100055 BP	Plan: 1615 Two Story SFR -1997 UBC	2002



Accessory Dwelling Units

Index # - File Name: 1.0022 - Single Family Dwellings Data\_Snohomish County.pdf

New	Approved Basic #01-108242 BP	Plan No. 1896 Two Story SFR.....1997 UBC	2002
New	Approved Basic #01-108239 BP	Plan No. 1792 2-story style SFR.....1997 UBC	2002
New	Approved Basic #01-108244 BP	Plan No. 2021 2-story style SFR.....1997 UBC	2002
New	Approved Basic #01-108239 BP	Plan No. 1792 2-story style SFR.....1997 UBC	2002
New	Approved Basic #02-100055 BP	Plan: 1615 Two Story SFR -1997 UBC	2002
New	Approved Basic #02-101372 BP	Plan: 22107A Ruston Two Story SFR - 1997 UBC	2002
New	Mid-Entry style SFR.....1997 UBC	Plan No. 2321-H	2002
New	Approved Basic #01-112737 BP	Plan: 2170 Hip Two Story SFR - 1997 UBC	2002
New	Approved Basic #01-112730 BP	Plan: 1920 Hip Two Story SFR - 1997 UBC	2002
New	Approved Basic #01-112731 BP	Plan: 2164 Gable Two Story SFR - 1997 UBC	2002
New	Approved Basic #01-112735 BP	Plan: 2288 Gable Two Story SFR - 1997 UBC	2002
New	Approved Basic #01-112732 BP	Plan: 1920 Gable Two Story SFR - 1997 UBC	2002
New	Approved Basic #01-112735 BP	Plan: 2288 Gable Two Story SFR - 1997 UBC	2002
New	Approved Basic #01-112730 BP	Plan: 1920 Hip Two Story SFR - 1997 UBC	2002
New	Approved Basic #01-112729 BP	Plan No. 2321-Hip Split level SFR w/finished	2002
New	Approved Basic #01-112969 BP	Plan No. 2321 Mid-entry SFR - 1997 UBC	2002
New	Approved Basic #01-112967 BP	Plan No. 1920 Two Story SFR - 1997 UBC	2002
New	Approved Basic #01-112969 BP	Plan No. 2321 Mid-entry SFR - 1997 UBC	2002
New	Approved Basic #01-112738 BP	Plan: 2170 Gable Two Story SFR - 1997 UBC	2002
New	2001 Golden West 01-441F 27 x 44		2002
New	Approved Basic #99-109776 BP	Plan: 2397 w/bonus Two Story SFR - 1997 UBC	C 2002
New	Approved Basic #02-101388 BP	Plan: 2189 (Sherwin) Two Story SFR - 1997 UBC	2002
New	Approved Basic #01-107262 BP	Plan: . 2342 Two Story SFR.....1997 UBC	2002
New	Approved Basic #01-107262 BP	Plan: . 2342 Two Story SFR.....1997 UBC	2002
New	27 x 50 2001 Greenbrier		2002
New	2 story SFR		2002
New	Approved Basic #01-111345 BP	Plan 1965-K Two-story style SFR.....1997 UBC	2002
New	Rambler w/basement		2002
New	Rambler w/garage		2002
New	Approved Basic #02-103160 BP	Plan 1965-K SSI Two-story style SFR.....1997 UBC	2002
New	Approved Basic #01-107262 BP	Plan: . 2342 Two Story SFR.....1997 UBC	2002
New	Approved Basic #01-111345 BP	Plan 1965-K Two-story style SFR.....1997 UBC	2002
New	Approved Basic #02-103158 BP	Plan 2342 SSI Two-story style SFR.....1997 UBC	2002
New	Approved Basic #02-103157 BP	Plan No. 2108 SSI Two Story SFR - 1997 UBC	2002
New	Approved Basic #01-107263 BP	Plan:. 2180 Two Story SFR.....1997 UBC	2002
New	Approved Basic #02-103160 BP	Plan 1965-K SSI Two-story style SFR.....1997 UBC	2002
New	Approved Basic #01-111345 BP	Plan 1965-K Two-story style SFR.....1997 UBC	2002
New	Approved Basic #01-107262 BP	Plan: . 2342 Two Story SFR.....1997 UBC	2002
New	Approved Basic #01-107263 BP	Plan:. 2180 Two Story SFR.....1997 UBC	2002
New	Approved Basic #01-107263 BP	Plan:. 2180 Two Story SFR.....1997 UBC	2002
New	Approved Basic #01-111345 BP	Plan 1965-K Two-story style SFR.....1997 UBC	2002
New	Approved Basic #01-107264 BP	Plan No. 2108 Two Story SFR - 1997 UBC	2002
New	Approved Basic #01-107262 BP	Plan: . 2342 Two Story SFR.....1997 UBC	2002
New	Approved Basic #01-111345 BP	Plan 1965-K Two-story style SFR.....1997 UBC	2002
New	Approved Basic #01-107263 BP	Plan:. 2180 Two Story SFR.....1997 UBC	2002
New	Two Story SFR - 1997 UBC	Plan: 2108	2002
New	Approved Basic #01-111345 BP	Plan 1965-K Two-story style SFR.....1997 UBC	2002

Accessory Dwelling Units

Index # - File Name: 1.0022 - Single Family Dwellings Data\_Snohomish County.pdf

New	Approved Basic #01-107263 BP	Plan:. 2180 Two Story SFR....1997 UBC	2002
New	Approved Basic #01-107263 BP	Plan:. 2180 Two Story SFR....1997 UBC	2002
New	Approved Basic #02-103157 BP	Plan No. 2108 SSI Two Story SFR - 1997 UBC	2002
New	Two-story SFR - 1997 UBC		2002
New	2-Story SFR w/attached garage and covered porches.		2002
New	Two-story SFR - 1997UBC	Plan M2590A2F-0	2002
New	Approved Basic #99-109776 BP	Plan: 2397 w/bonus Two Story SFR - 1997 UBC	O 2002
New	Approved Basic #99-109776 BP	Plan: 2397 w/bonus Two Story SFR - 1997 UBC	O 2002
New	Two Story SFR - 1997 UBC	Plan: 1887 - side	2002
New	Two Story SFR - 1997 UBC	Plan: 1887	2002
New	Approved Basic #01-113640 BP	Plan: 1887-side Two Story SFR - 1997 UBC	2002
New	Two-story SFR - 1997 UBC	Plan M2590A2F-0	2002
New	Approved Basic #01-113642 BP	Plan: 1887- front Two Story SFR - 1997 UBC	2002
New	Two Story SFR with Attached Garage 1997UBC	Plan # M2415A3F	2002
New	Approved Basic #02-101809 BP	Plan: Adams/Gable (B) Two Story SFR - 1997 UBC	2002
New	Approved Basic #02-100866 BP	Plan: Whitney - Hip Two Story SFR - 1997 UBC	2002
New	Approved Basic #02-100290 BP	Plan: Adams/Gable Two Story SFR - 1997 UBC	2002
New	Approved Basic #02-100875 BP	Plan: Olympic/Gable Two Story SFR - 1997 UBC	2002
New	Approved Basic #02-100295 BP	Plan: Shasta/Gable Two Story SFR - 1997 UBC	2002
New	Approved Basic #02-101809 BP	Plan: Adams/Gable (B) Two Story SFR - 1997 UBC	2002
New	Approved Basic #01-113070 BP	Plan: Stewart/Gable SFR w/finished lower floor - 1997	2002
New	Approved Basic #02-101812 BP	Plan: Whitney - Hip (B) Two Story SFR - 1997 UBC	2002
New	Approved Basic #02-101809 BP	Plan: Adams/Gable (B) Two Story SFR - 1997 UBC	2002
New	Approved Basic #02-100866 BP	Plan: Whitney - Hip Two Story SFR - 1997 UBC	2002
New	Approved Basic #02-101814 BP	Plan: Olympic/Gable (B) Two Story SFR - 1997 UBC	2002
New	Approved Basic #02-100295 BP	Plan: Shasta/Gable Two Story SFR - 1997 UBC	2002
New	Approved Basic #02-102796 BP	Plan: Trinity/Gable (B) Two Story SFR - 1997 UBC	2002
New	Approved Basic #02-102329 BP	Plan: Stewart/Gable (B) SFR w/finished lower floor	2002
New	Approved Basic #02-101809 BP	Plan: Adams/Gable (B) Two Story SFR - 1997 UBC	2002
New	Approved Basic #02-100295 BP	Plan: Shasta/Gable Two Story SFR - 1997 UBC	2002
New	Approved Basic #02-102796 BP	Plan: Trinity/Gable (B) Two Story SFR - 1997 UBC	2002
New	Approved Basic #01-101569 BP	Plan: 1885 T/A Tri-Level SFR - 1997 UBC	2002
New	Approved Basic #02-103330 BP	Plan: Whitney/Gable Two Story SFR - 1997 UBC	2002
New	Approved Basic #02-101812 BP	Plan: Whitney - Hip (B) Two Story SFR - 1997 UBC	2002
New	Approved Basic #02-102796 BP	Plan: Trinity/Gable (B) Two Story SFR - 1997 UBC	2002
New	Approved Basic #02-100295 BP	Plan: Shasta/Gable Two Story SFR - 1997 UBC	2002
New	Approved Basic #02-100295 BP	Plan: Shasta/Gable Two Story SFR - 1997 UBC	2002
New	Approved Basic #02-102796 BP	Plan: Trinity/Gable (B) Two Story SFR - 1997 UBC	2002
New	Approved Basic #02-102796 BP	Plan: Trinity/Gable (B) Two Story SFR - 1997 UBC	2002
New	Approved Basic #02-101812 BP	Plan: Whitney - Hip (B) Two Story SFR - 1997 UBC	2002
New	Approved Basic #02-100295 BP	Plan: Shasta/Gable Two Story SFR - 1997 UBC	2002
New	Approved Basic #01-101569 BP	Plan: 1885 T/A Tri-Level SFR - 1997 UBC	2002
New	Approved Basic #01-113070 BP	Plan: Stewart/Gable SFR w/finished lower floor - 1997	2002
New	Approved Basic #02-100290 BP	Plan: Adams/Gable Two Story SFR - 1997 UBC	2002
New	Two Story SFR - 1997 UBC	Plan: Shasta/Gable	2002
New	Approved Basic #02-100293 BP	Plan: Trinity/Gable Two Story SFR - 1997 UBC	2002
New	Approved Basic #01-113070 BP	Plan: Stewart/Gable SFR w/finished lower floor - 1997	2002

Accessory Dwelling Units

Index # - File Name: 1.0022 - Single Family Dwellings Data\_Snohomish County.pdf

New	2 story sfr w/unfinished basement & 3 car garage		2002
New	27x44, 2002 Marlette		2002
New	Two-story SFR with finished basement - 1997 UBC		2002
New	27x58 2002 Marlette		2002
New	1192 sf Rambler w/484 sf garage and 48 sf open deck		2002
New	Approved Basic #02-101235 BP	Plan: 1192 Rambler Style SFR - 1997 UBC	2002
New	Approved Basic #02-101235 BP	Plan: 1192 Rambler Style SFR - 1997 UBC	2002
New	Approved Basic #02-101235 BP	Plan: 1192 Rambler Style SFR - 1997 UBC	2002
New	Rambler Style SFR - 1997 UBC		2002
New	Approved Basic #02-101235 BP	Plan: 1192 Rambler Style SFR - 1997 UBC	2002
New	Approved Basic #02-101235 BP	Plan: 1192 Rambler Style SFR - 1997 UBC	2002
New	Two-story SFR with 784sf finished & 234 unfinished basement		2002
New	Approved Basic #00-105331 BP	Bldrs Plan No. 1932 Two Story SFR - 1997 UBC	2002
New	Approved Basic #00-103052-BP	Plan:1621-3C Two Story SFR - 1997 UBC	2002
New	Approved Basic #00-104229 BP	Plan: 1533 revised Two Story SFR - 1997 UE	2002
New	Rambler w/attached garage		2002
New	Rambler w/garage and covered deck/porch		2002
New	Two Story SFR with Attached Garage		2002
New	Approved Basic #00-103052-BP	Plan:1621-3C Two Story SFR - 1997 UBC	2002
New	Approved Basic #00-104229 BP	Plan: 1533 revised Two Story SFR - 1997 UE	2002
New	Approved Basic #00-105333 BP	Plan: 1502 Rambler Style SFR - 1997 UBC	2002
New	Approved Basic #02-109089 BP	Plans #1420 Rambler Style SFR - 1997 UBC	2002
New	Approved Basic #00-100660 BP	Plan: 1803 Rambler Style SFR - 1997 UBC	2002
New	One-story SFR w/attached garage		2002
New	Approved Basic #00-105331 BP	Bldrs Plan No. 1932 Two Story SFR - 1997 UBC	2002
New	SFR with Finished Basement and Attached Garage		2002
New	Approved Basic #02-107995 BP	Plan #1810 Rambler Style SFR - 1997 UBC	2002
New	2-Story SFR w/attached garage.		2002
New	2-story SFR w/attached garage.		2002
New	One-story SFR with semi-finished basement		2002
New	Two SFR with Finished Basement and Attached Garage		2002
New	Rambler Style SFR w/attached garage. - 1997 UBC		2002
New	Rambler Style SFR - 1997 UBC		2002
New	2-story SFR w/attached garage.		2002
New	Approved Basic #99-113027 BP	Plan: 2621 Two Story SFR - 1997 U	2002
New	2-Story SFR w/attached garage.		2002
New	Approved Basic #01-108101 BP	Plan: 2386 Two Story SFR - 1997 UBC	2002
New	Approved Basic #00-111020 BP	Plan: 1980 - revised interior floor plan Rambler Sty	2002
New	Approved Basic #01-111895 BP	Rambler Style SFR - 1997	2002
New	Two-story SFR w/attached garage		2002
New	Two-story SFR w/attached garage		2002
New	Rambler style SFR with attached garage		2002
New	2 Story w/ 3 Car		2002
New	2-story SFR w/garage and covered deck/porch		2002
New	2 story SFR with unfinished basement		2002
New	27 x 52 2002 Fleetwood Blackline		2002
New	Approved Basic #01-107405 BP	Plan: 1446 Rambler Style SFR - 1997 UBC	2002

Accessory Dwelling Units

Index # - File Name: 1.0022 - Single Family Dwellings Data\_Snohomish County.pdf

New	Approved Basic #01-107401BP	Plan: 1520 Rambler Style SFR - 1997 UBC	2002
New	Approved Basic #01-107401BP	Plan: 1520 Rambler Style SFR - 1997 UBC	2002
New	Approved Basic #01-107401BP	Plan: 1520 Rambler Style SFR - 1997 UBC	2002
New	Approved Basic #01-107401BP	Plan: 1520 Rambler Style SFR - 1997 UBC	2002
New	Approved Basic #01-104132 BP	Plan: 2895 Two Story SFR - 1997 UBC	2002
New	Approved Basic #99-113027 BP	Plan: 2621 Two Story SFR - 1997 UBC	2002
New	Approved Basic #99-109807 BP	Plan: 2768 Two Story SFR - 1997 UBC	Of 2002
New	Approved Basic #01-103350 BP	Bldrs Plan No. 2990 Two-story style SFR.....19	2002
New	Approved Basic #99-109807 BP	Plan: 2768 Two Story SFR - 1997 UBC	Of 2002
New	Approved Basic #01-104132 BP	Plan: 2895 Two Story SFR - 1997 UBC	2002
New	Approved Basic #99-109807 BP	Plan: 2768 Two Story SFR - 1997 UBC	Of 2002
New	Approved Basic #01-104132 BP	Plan: 2895 Two Story SFR - 1997 UBC	2002
New	Approved Basic #01-111895 BP	Rambler Style SFR - 1997	2002
New	2 Story SFR w/attached garage.		2002
New	2508 Rambler w/730 sf garage & 120 sf patio		2002
New	Approved Basic #01-103350 BP	Bldrs Plan No. 2990 Two-story style SFR.....19	2002
New	Approved Basic #99-109807 BP	Plan: 2768 Two Story SFR - 1997 UBC	Of 2002
New	Approved Basic #01-107401BP	Plan: 1520 Rambler Style SFR - 1997 UBC	2002
New	Approved Basic #01-107405 BP	Plan: 1446 Rambler Style SFR - 1997 UBC	2002
New	Approved Basic #01-107405 BP	Plan: 1446 Rambler Style SFR - 1997 UBC	2002
New	Approved Basic #01-107401BP	Plan: 1520 Rambler Style SFR - 1997 UBC	2002
New	Approved Basic #01-107405 BP	Plan: 1446 Rambler Style SFR - 1997 UBC	2002
New	Approved Basic #01-107405 BP	Plan: 1446 Rambler Style SFR - 1997 UBC	2002
New	Approved Basic #01-107401BP	Plan: 1520 Rambler Style SFR - 1997 UBC	2002
New	Approved Basic #01-107401BP	Plan: 1520 Rambler Style SFR - 1997 UBC	2002
New	2002 Valley Mansion 40 x 60		2002
New	Approved Basic #02-106706 BP	Plan: 9964-A1 Two Story SFR - 1997 UBC	2002
New	Approved Basic #99-113027 BP	Plan: 2621 Two Story SFR - 1997 UBC	2002
New	Approved Basic #99-109807 BP	Plan: 2768 Two Story SFR - 1997 UBC	Of 2002
New	Approved Basic #99-109807 BP	Plan: 2768 Two Story SFR - 1997 UBC	Of 2002
New	Approved Basic #01-108192BP	Plan: 2397 Two-story SFR - 1997 UBC	2002
New	Approved Basic #01-103350 BP	Bldrs Plan No. 2990 Two-story style SFR.....19	2002
New	Approved Basic #02-101164 BP	Plan: 5252 Two Story SFR - 1997 UBC	2002
New	Approved Basic #02-101164 BP	Plan: 5252 Two Story SFR - 1997 UBC	2002
New	Two Story SFR - 1997 UBC	Plan: 5252	2002
New	Two Story SFR - 1997 UBC	Plan: 5552 B	2002
New	Approved Basic #01-111230 BP	Plan: 5250 Two Story SFR - 1997 UBC	2002
New	Approved Basic #01-111230 BP	Plan: 5250 Two Story SFR - 1997 UBC	2002
New	Approved Basic #01-111230 BP	Plan: 5250 Two Story SFR - 1997 UBC	2002
New	Two Story SFR - 1997 UBC	Plan: 5554-B	2002
New	One story SFR - 1997 UBC	Bldrs Plan #R3-2118B	2002
New	Approved Basic #01-111269 BP	Plan: 5118 B (bath) - revised Two Story SFR - 1997	2002
New	Two-story SFR	Builder s Plan 5023-A-RK	2002
New	Two-story SFR w/attached garage		2002
New	Two-story SFR		2002
New	Approved Basic #99-113971 BP	Plan: 1315 Split Level SFR - 1997 UBC	2002
New	Two-story SFR		2002

Accessory Dwelling Units

Index # - File Name: 1.0022 - Single Family Dwellings Data\_Snohomish County.pdf

New	Approved Basic #99-113971 BP	Plan: 1315 Split Level SFR - 1997 UBC	2002
New	Approved Basic #02-104714 BP	Plan: R 3-3118 B Rambler Style SFR - 1997 UBC	2002
New	Rambler style SFR w/attached garage.		2002
New	Rambler Style SFR - 1997 UBC		2002
New	Two Story SFR - 1997 UBC	Plan: 5411 A	2002
New	2-Story SFR w/attached garage.		2002
New	Approved Basic #02-108181 BP	Plan MU2/3-2767/3028 Two-Story SFR - 1997 UBC	2002
New	1965 sf 2-story w/448 sf garage		2002
New	2 story SFR with attached garage		2002
New	Two-story SFR		2002
New	Approved Basic #01-112724 BP	Plan: 5222 C-2 Two Story SFR - 1997 UBC	2002
New	Two-story SFR		2002
New	Two-story SFR		2002
New	2 story SFR with attached garage		2002
New	Approved Basic #01-111259 BP	Plan: 5018 A (bath) -revised Two Story SFR - 199	2002
New	Two Story SFR - 1997 UBC	Plan: 5018 B-C-RS	2002
New	Approved Basic #99-114152 BP	Plan: 5522 w/bonus Two Story SFR - 1997 UBC	2002
New	Two Story SFR - 1997 UBC	Plan: 5018 B-B-LS	2002
New	Two Story SFR - 1997 UBC	Plan: 5022 FB-B2-LG	2002
New	Approved Basic #01-111261 BP	Plan: 5018 C (bath)-revised Two Story SFR - 1997	2002
New	28 x 60 2003 Goldenwest		2002
New	Rambler w/ 3 Car		2002
New	Two Story SFR - 1997 UBC		2002
New	Two Story SFR - 1997 UBC	Plan: 5511	2002
New	Approved Basic #99-101211BP	Plan: 5023/5123 w/bonus rm Two Story SFR - 1997 UBC	2002
New	Approved Basic #99-101211BP	Plan: 5023/5123 w/bonus rm Two Story SFR - 1997 UBC	2002
New	Approved Basic #01-111264 BP	Plan: 5018 C - revised Two Story SFR - 1997 UBC	2002
New	Approved Basic #99-114152 BP	Plan: 5522 w/bonus Two Story SFR - 1997 UBC	2002
New	Two Story SFR - 1997 UBC		2002
New	Two Story SFR - 1997 UBC		2002
New	Approved Basic #99-103342BP	Plan: 5222 Two Story SFR - 1997 UBC	2002
New	Two Story SFR - 1997 UBC	Plan: 5511 A-3L	2002
New	Approved Basic #99-103342 BP	Plan: 5222 Two Story SFR - 1997 UBC Option	2002
New	Approved Basic #99-101211BP	Plan: 5023/5123 w/bonus rm Two Story SFR - 1997 UBC	2002
New	Approved Basic #99-103342BP	Plan: 5222 Two Story SFR - 1997 UBC	2002
New	Two Story SFR - 1997 UBC	Plan: 5412 C-2L	2002
New	Approved Basic #02-103683 BP	Plan: 5522 B- L (dropped) Two Story SFR - 1997 UBC	2002
New	2 Story w/ 2 Car		2002
New	Approved Basic #99-101211BP	Plan: 5023/5123 w/bonus rm Two Story SFR - 1997 UBC	2002
New	Two Story SFR - 1997 UBC	Plan: 5210	2002
New	Two Story SFR - 1997 UBC	Plan: 5411	2002
New	Approved Basic #99-103342BP	Plan: 5222 Two Story SFR - 1997 UBC	2002
New	Two Story SFR - 1997 UBC	Bldrs Plan #MU3-2732A	2002
New	Rambler style SFR w/attached garage.		2002
New	One story SFR - 1997 UBC	Bldrs Plan #R3-2118A	2002
New	2 story SFR w/attached garage.		2002
New	Approved Basic #02-108765 BP	Plan: MU2732A Two Story SFR - 1997 UBC	2002

Accessory Dwelling Units

Index # - File Name: 1.0022 - Single Family Dwellings Data\_Snohomish County.pdf

New	Approved Basic #02-109035-BP	Plan: R3-2118A	Rambler Style SFR - 1997 UBC	2002
New	Two Story SFR with Attached Garage			2002
New	Approved Basic #01-111266 BP	Plan: 5118 B - revised	Two Story SFR - 1997 UBC	2002
New	Approved Basic #99-101211BP	Plan: 5023/5123 w/bonus rm	Two Story SFR - 1997 UBC	2002
New	2 Story W/ 3 Car			2002
New	2 story SFR w/attached garage		Plan #5023-B-L	2002
New	2 story SFR w/ attached garage		Plan #5022-F-C-LD	2002
New	2 story SFR w/ attached garage		Plan #5022F-C-LD	2002
New	2 story SFR w/ attached garage		Plan #5022-BF-B-R	2002
New	Two Story SFR - 1997 UBC	Plan: 5511 A		2002
New	Two Story SFR - 1997 UBC	Plan: 5412 B		2002
New	1920 sf 2-story w/350 sf garage and 96 sf open deck/patio			2002
New	Two Story SFR - 1997 UBC	Plan: 5210 B		2002
New	Two-story SFR - 1997 UBC			2002
New	Two-story SFR - 1997UBC			2002
New	Approved Basic #01-113535 BP	Bldrs Plan: 2150 Rambler	Rambler style SFR - 1997 UBC	2002
New	Approved Basic #01-113535 BP	Bldrs Plan: 2150 Rambler	Rambler style SFR - 1997 UBC	2002
New	One-story SFR over garage/storage			2002
New	2-Story SFR w/attached garage			2002
New	3 story SFR with attached garage			2002
New	Two-story SFR with attached 3-car garage - 1997 UBC			2002
New	Two-story SFR with attached 3-car garage - 1997 UBC			2002
New	2-story w/ garage			2002
New	Approved Basic #01-108244 BP	Plan No. 2021	2-story style SFR.....1997 UBC	2002
New	Rambler w/basement & attached garage			2002
New	Tri-level SFR w/attached garage.			2002
New	2-story w/attached garage			2002
New	Two-story SFR w/unfinished basement			2002
New	2002 Palm Harbor 71 x 41			2002
New	Approved Basic #01-106755 BP	Plan: 704 - revised	Two Story SFR - 1997 UBC	2002
New	Approved Basic #01-106756 BP	Plan: 705 - revised	Two Story SFR - 1997 UBC	2002
New	Approved Basic #01-106754 BP	Plan: 703 - revised	Two Story SFR - 1997 UBC	2002
New	Approved Basic #01-106753 BP	Plan: 702 revised	Two Story SFR - 1997 UBC	2002
New	Approved Basic #01-106756 BP	Plan: 705 - revised	Two Story SFR - 1997 UBC	2002
New	Approved Basic #01-106757 BP	Plan: 706 - revised	Two Story SFR - 1997 UBC	2002
New	Approved Basic #01-106756 BP	Plan: 705 - revised	Two Story SFR - 1997 UBC	2002
New	Approved Basic #01-106757 BP	Plan: 706 - revised	Two Story SFR - 1997 UBC	2002
New	Approved Basic #01-106754 BP	Plan: 703 - revised	Two Story SFR - 1997 UBC	2002
New	Approved Basic #01-106756 BP	Plan: 705 - revised	Two Story SFR - 1997 UBC	2002
New	Approved Basic #01-106754 BP	Plan: 703 - revised	Two Story SFR - 1997 UBC	2002
New	Approved Basic #01-106755 BP	Plan: 704 - revised	Two Story SFR - 1997 UBC	2002
New	Approved Basic #01-106753 BP	Plan: 702 revised	Two Story SFR - 1997 UBC	2002
New	Approved Basic #01-106756 BP	Plan: 705 - revised	Two Story SFR - 1997 UBC	2002
New	Approved Basic #01-105838 BP	Plan: 554 R	Two Story SFR.....1997 UBC	2002
New	Approved Basic #01-105843 BP	Plan: 556 R	Two style SFR.....1997 UBC	2002
New	Approved Basic #01-106889 BP	Plan: 1905	Rambler Style SFR - 1997 UBC	2002
New	Two-story SFR - 1997 UBC			2002

Accessory Dwelling Units

Index # - File Name: 1.0022 - Single Family Dwellings Data\_Snohomish County.pdf

New	Approved Basic #01-105838 BP	Plan: 554 R	Two Story SFR.....1997 UBC	2002
New	Approved Basic #01-106757 BP	Plan: 706 - revised	Two Story SFR - 1997 UBC	2002
New	Approved Basic #01-106757 BP	Plan: 706 - revised	Two Story SFR - 1997 UBC	2002
New	Approved Basic #01-106756 BP	Plan: 705 - revised	Two Story SFR - 1997 UBC	2002
New	Rambler style SFR with attached garage			2002
New	Approved Basic #00-107717 BP	Bldrs Plan No. 1890	Rambler style SFR.....1997 U	2002
New	Two-story SFR - 1997 UBC			2002
New	Two Story SFR - 1997 UBC			2002
New	Two Story SFR - 1997 UBC			2002
New	Two Story SFR - 1997 UBC			2002
New	Two Story SFR - 1997 UBC			2002
New	Two Story SFR w/finished basement - 1997 UBC			2002
New	Two Story SFR - 1997 UBC			2002
New	Two-story SFR - 1997 UBC			2002
New	Two Story SFR - 1997 UBC			2002
New	Two Story SFR - 1997 UBC			2002
New	Two Story SFR - 1997 UBC			2002
New	Two Story SFR - 1997 UBC			2002
New	Two Story SFR - 1997 UBC			2002
New	Two Story SFR - 1997 UBC			2002
New	3392 sf 2-story w/616sf garage, & 67 sf covered deck/porch			2002
New	Two Story SFR - 1997 UBC			2002
New	50 X 40 2002 Meadow View			2002
New	Two-story SFR w/attached garage			2002
New	2-Story SFR w/attached garage			2002
New	2-story w/ garage, covered deck & porch			2002
New	2415 SF SFR W/3 car garage			2002
New	Approved Basic #01-106945 BP	Plan #2265 C/2-3	Two Story SFR - 1997 UBC	2002
New	Approved Basic #99-109807 BP	Plan: 2768	Two Story SFR - 1997 UBC	Of 2002
New	2 story log house w/ attached garage			2002
New	2 Story w/ 3 Car			2002
New	SFR w/attached garage			2002
New	SFR w/ Semi-finished Basement & 2 Car Garage			2002
New	Approved Basic #01-113535 BP	Plan: 2150 Rambler	Rambler style SFR - 1997 UBC	2002
New	2320sf rambler with attached garage - 1997UBC			2002
New	Approved Basic #99-109698 BP	Builder Plan # 7840-A w/Bonus Rm	Two Story SFR - 1997	2002
New	Approved Basic #99-110065-BP	Bldrs Plan # 7360.	2-Story SFR w/attached 3	2002
New	Approved Basic #99-109701 BP	Plan # 7856	Two Story SFR - 1997 UBC	2002
New	Approved Basic #02-107764 BP	Plan # 7840-A w/Bonus Rm	Two Story SFR - 1997 UBC	2002
New	2-story w/ unfinished basement, garage			2002
New	Approved Basic #02-104947 BP	Plan: 7362	Two-story SFR - 1997 UBC	2002
New	Approved Basic #99-109698 BP	Builder Plan # 7840-A w/Bonus Rm	Two Story SFR - 1997	2002
New	Approved Basic #02-108745 BP	Plan 7360	Two Story SFR - 1997 UBC	2002
New	2 Story SFR with attached garage			2002
New	Approved Basic #99-109328BP	Plan: 8270	Two Story SFR - 1997 UBC	2002
New	Approved Basic #99-112337 BP	Plan: 7260	Two Story SFR - 1997 UBC	2002
New	Approved Basic #99-110065-BP	Bldrs Plan # 7360.	2-Story SFR w/attached 3	2002
New	Approved Basic #99-109701 BP	Plan # 7856	Two Story SFR - 1997 UBC	2002
New	Approved Basic #99-110420 BP	Bldrs Plan 8230-A	2-Story SFR w/attache	2002

Accessory Dwelling Units

Index # - File Name: 1.0022 - Single Family Dwellings Data\_Snohomish County.pdf

New	Approved Basic #99-109701 BP	Plan # 7856	Two Story SFR - 1997 UBC	2002
New	Approved Basic #99-110065-BP	Bldr's Plan # 7360.	2-Story SFR w/attached 3	2002
New	Two Story 900 Sq Ft Garage with 690 Sq Ft SFR Second Floor			2002
New	Rambler style SFR w/attached garage.			2002
New	1728sf one-story SFR -- 1997 UBC			2002
New	2-story SFR - 1997UBC			2002
New	Rambler Style SFR - 1997 UBC			2002
New	2-Story SFR w/attached garage			2002
New	2-story style SFR.....1997 UBC			2002
New	Rambler style SFR w/attached garage.			2002
New	2 Story SFR with covered porch			2002
New	2 story SFR w/unfinished basement and attached garage.			2002
New	Convert 844 sf of 2nd floor storage to detached accessory Apartment - 1997 UBC			2002
New	SFR w/ Partially Finished Basement, 2 Car Garage			2002
New	1402 sf w/1227 sf finished basement, 595 sf garage, 192 sf covered deck/porch and 370 sf open			2002
New	Rambler Style SFR - 1997 UBC			2002
New	2-Story SFR w/attached garage.			2002
New	Approved Basic #01-110781 BP	Plan: 1315 Side Garage	Split Level SFR - 1997 U	2002
New	Two Story SFR - 1997 UBC. EXPIRED W/O COUNTY APPROVAL TO OCCUPY OR USE. PERMIT SEN			2002
New	2-story w/unfinished basement & garage			2002
New	Two-story SFR w/attached garage			2002
New	40 x 52 2003 Skyline			2002
New	2-story style SFR w/attached garage & carport, with 208 sq ft sunroom & storage space over the			2002
New	Convert existing MH/TD to permanent residence			2002
New	Daylight basement style SFR.			2002
New	2834 2-story w/876 garage, and 24 sf covered deck/porch			2002
New	Two Story SFR w/unfinished basement - 1994 UBC	Plan #Amherst		2002
New	2 Story w/ semi finished basement & 3 Car Garage			2002
New	Approved Basic #99-109698 BP	Builder Plan # 7840-A w/Bonus Rm	Two Story SFR - 1997	2002
New	Approved Basic #99-110420 BP	Bldr's Plan 8230-A	2-Story SFR w/attache	2002
New	2 Story w/ 3 Car & Unfin Basement			2002
New	14 x 52 1978 Fleetwood			2002
New	Two-story SFR - 1997 UBC			2002
New	Two Story SFR - 1997 UBC			2002
New	One-story SFR with semi-finished basement. Basement plumbing to be rough-in only.			2002
New	Two-story SFR w/attached garage			2002
New	28x70, 2002 Palm Harbor			2002
New	Rambler style SFR w/finished basement & 3-car garage...1997 UBC			2002
New	Two-story SFR with attached garage - 1997 UBC. Closed and combined with Permit #03-10117			2002
New	Approved Basic #01-106899 BP	Plan #1810	Rambler Style SFR - 1997 UBC	2002
New	Approved Basic #01-106899 BP	Plan #1810	Rambler Style SFR - 1997 UBC	2002
New	2 Story w/ 3 Car			2002
New	2-story SFR w/attached 3-car garage.....1997 UBC			2002
New	Two-story SFR - 1997 UBC			2002
New	Rambler style SFR w/attached garage.			2002
New	2378 Rambler w/950 sf garage and 56 sf covered porch			2002
New	2 story sfr w/attached 3 car garage			2002



Accessory Dwelling Units

Index # - File Name: 1.0022 - Single Family Dwellings Data\_Snohomish County.pdf

New	Approved Basic #01-111544 BP	Plan: 1008	Rambler Style SFR - 1997 UBC	2002
New	2 Story w/ 3/Car	*Applicant needs to apply for a FP permit- needs DNR permit prior to framing		2002
New	2002 Golden West 28x66			2002
New	2 story sfr w/3 car garage			2002
New	SFR over garage			2002
New	2 Story with 3 Car Garage			2002
New	SFR w/finished basement, 2056 sf garage, 216 sf covered deck/porch and 224 sf open deck			2002
New	27x56, 1990 Orchard Cove			2002
New	2-story SFR w/attached garage			2002
New	One-story SFR w/attached garage			2002
New	One-story SFR			2002
New	Rambler w/garage, bonus room, and covered deck/porch			2002
New	28 x 40 2002 Redman Discovery			2002
New	2 story SFR with semi-finished basement			2002
New	Rambler Style SFR - 1997 UBC			2002
New	27x52, 2002 Fleetwood			2002
New	2-story Dupex with attached garages and covered porches.			2002
New	2 Story Single Family Residence w/ fin bsmt & 4 Car Garage			2002
New	Two-story SFR with semi-finished basement - 1997 UBC			2002
New	Conversion of existing Mobile Home to Guesthouse			2002
New	Two-story SFR			2002
New	692 sf Accessory Apartment with attached shop			2002
New	Two-story SFR w/attached garage			2002
New	14 x 56 1977 Kentwood			2002
New	1630 sf 2-story w/400 sf garage , 150 sf covered deck/porch and 144 sf patio			2002
New	2-Story garage with heated living space (office & bath) on 2-nd floor.			2002
New	Two Story SFR with Attached Garage			2002
New	56 x 39 Two Story SFR with Attached Garage			2002
New	Two-story SFR			2002
New	Rambler style SFR w/attached garage.			2002
New	Rambler Style SFR with attached garage. EXPIRED W/O COUNTY APPROVAL TO OCCUPY OR U!			2002
New	2 Story SFR w/ Loft			2002
New	Convert existing MH to Guest House			2002
New	66 x 28 1998 Golden West			2002
New	3262 sf 2-story w/744 sf garage and 42 sf covered deck/porch			2002
New	Convert Existing 1992, Marlette Mobile Home to Guesthouse			2002
New	1971sf one-story SFR with attached garage with 417sf unfinished storage area - 1997 UBC			2002
New	28x40 (1998) Liberty			2002
New	27 4 x 66 -- 2001 -- Redman			2002
New	Approved Basic #02-106330 BP	Plan: 1144	Rambler Style SFR - 1997 UBC	2002
New	Two Story SFR - 1997 UBC			2002
New	Two Story SFR - 1997 UBC			2002
New	2 story SFR with attached garage			2002
New	Convert existing Temporary Dwelling approved under 95-107119TD into permanent residence.			2002
New	Two Story SFR with Attached Garage and 242 Sq Ft Fin and 460 Sq Ft Unfinished Basement			2002
New	Rambler w/garage			2002
New	Two Story SFR with Unfinished Basement and Attached Garage			2002

Accessory Dwelling Units

Index # - File Name: 1.0022 - Single Family Dwellings Data\_Snohomish County.pdf

New	2472 sf 2-story w/480 sf garage		2002
New	Two-story SFR with attached garage - 1997 UBC		2002
New	Approved Basic #98-110504BP	Plan #2195 Split Level SFR - 1997 UBC	2002
New	3922 sf 2-story w/1258 sf garage and 605 sf covered deck/porch		2002
New	Convert Existing SFR to Duplex - 1997 UBC		2002
New	Duplex with attached garages and covered porches		2002
New	Two-story SFR - 1997 UBC		2002
New	28x56 1986 Champion Gurdian		2002
New	Two Story SFR- 1997 UBC		2002
New	Two Story w/finished basement - 1997 UBC		2002
New	Approved Basic #99-115750 BP	Two Story SFR - 1997 UBC	2002
New	Rambler style SFR w/attached garage.		2002
New	56 x 27 2002 Palm Harbor		2002
New	1054 s.f. sfr w/492 s.f. finished basement & 2 car garage		2002
New	Two-story SFR w/attached garage		2002
New	Two-story SFR. PERMIT OWNERSHIP TRANSFERRED TO E. & P. ADRIAN FROM S. JOHNSON, JULY		2002
New	2002 28 x 50 Silvercrest		2002
New	24x40 (1978) Champion #4784		2002
New	28 X 60 Fleetwood 1984		2002
New	Approved Basic #01-104109 BP	Plan: 1236 Mid Entry SFR - 1997 UBC	2002
New	Two-story SFR		2002
New	2002 Palm Harbor 52 x 41		2002
New	2002 Goldenwest 27 x 56		2002
New	625 sq ft Rambler SFR - 1997 UBC		2002
New	2 story SFR with unfinished daylight basement		2002
New	Two Story SFR with Attached Garage and Unfinished Basement		2002
New	Two-story SFR w/attached garage		2002
New	Rambler with Attached Garage		2002
New	1990 Golden West 28 x 66		2002
New	2 Story w/ Unfin Basement, replacing SFR destroyed by fire, being placed on existing foundation		2002
New	Approved Basic #01-111312 BP	Plan: 2431 Two Story SFR - 1997 UBC	2002
New	2808 2 story w/833 sf unfinished basement and 81 sf covered deck/porch (no garage)		2002
New	Rambler style SFR w/attached garage.		2002
New	One-story SFR		2002
New	27 X 44 Fleetwood 2002		2002
New	Rambler w/ Daylight Basement - 1997 UBC		2002
New	41x60, 2002 Ridgedale		2002
New	Convert existing MH to Guesthouse		2002
New	Two-story SFR		2002
New	2-story SFR w/attached garage.		2002
New	Two-story SFR w/attached garage		2002
New	2 Story w/ Finished Basement		2002
New	2-Story SFR w/attached garage, 180-sf covered porch and 120-sf solarium.		2002
New	2-Story SFR w/attached garage and covered porch.		2002
New	Rambler Style SFR - 1997 UBC		2002
New	2-Story SFR w/attached garage		2002
New	1698sf SFR with 540sf 2nd story unheated storage area - 1997 UBC		2002

Accessory Dwelling Units

Index # - File Name: 1.0022 - Single Family Dwellings Data\_Snohomish County.pdf

New	40 x 64	2002	Marlette		2002
New	28 x 64	1977	Sahar		2002
New	2 story SFR with attached garage and covered porch				2002
New	1815sf rambler with attached garage - 1997 UBC				2002
New	2 story SFR with attached garage				2002
New	Two story style SFR.....1997 UBC				2002
New	Convert 720 s.f. detached garage to accessory apartment				2002
New	Two Story SFR				2002
New	Two Story SFR - 1997 UBC		Plan: Frazier Residence		2002
New	63 x 27	2002	Westwood		2002
New	2 story SFR with 2 attached garages, two covered porches and a pool building. 12-03-02, PER CH				2002
New	24x50, 1972 Kenwood				2002
New	27 x 48	2002	Palm Harbor		2002
New	2-story - over daylight basement SFR w/attached garage and covered decks.				2002
New	Conversion of existing 950sf shop to living area to convert ex. SFR into duplex and proposed 138				2002
New	2047 split level w/garage				2002
New	Split-level entry SFR - 1997UBC				2002
New	SFR w/ finished basement and attached garage				2002
New	27x44, 1988 Fleetwood				2002
New	2350 sf 2-story w/garage				2002
New	Two Story SFR with Attached Garage/Shop				2002
New	36x64, 1979 Silvercrest Chalet				2002
New	Approved Basic #98-110213BP		Plan #1333 Two Story Duplex - 19		2002
New	Approved Basic #98-110213BP		Plan #1333 Two Story Duplex - 1997 UBC		2002
New	2002 Fleetwood 27 x 44				2002
New	2 story SFR with attached garage				2002
New	1824 sf rambler w/593 sf garage and 42 sf covered deck/porch w/120 sf patio				2002
New	Rambler w/ basement, covered deck/porch and open deck				2002
New	One story SFR Rambler				2002
New	3102 SF SFR w/ attached garage Pre-Construction Meeting held by Norm Nersten 7/16/02				2002
New	Approved Basic #01-110518 BP		Plan: 1587 SFR w/finished lower floor - 1997 UBC		2002
New	Convert existing 28x56 (1990) Fleetwood mobile home temporary dwelling to guesthouse				2002
New	52x40, 2002 Golden West				2002
New	SFR				2002
New	One-story SFR w/finished basement				2002
New	2 Story w/ finished basement & 2 Car Garage				2002
New	SFR Split-level entry - 1997 UBC		Plan 1926		2002
New	Rambler w/ 2 Car				2002
New	780 sf Accessory Apartment with attached garage				2002
New	2 story sfr w/semi-finished basement & 2 car garage				2002
New	2 Story SFR w/ unheated sunroom				2002
New	2 Story Duplex w Attched Garages				2002
New	Conversion of temporary dwelling to guesthouse				2002
New	850 sf Detached Accessory Apartment - 1997 UBC				2002
New	2 story SFR with attached garage				2002
New	2-Story SFR w/attached garage				2002
New	Rambler Style SFR - 1997 UBC				2002

Accessory Dwelling Units

Index # - File Name: 1.0022 - Single Family Dwellings Data\_Snohomish County.pdf

New	1906sf one-story SFR with attached garage - 1997UBC		2002
New	Convert Existing SFR to DetachedAccessory Apt, convert portion of 2nd floor to attic space		2002
New	Two Story SFR with Attached Garage		2002
New	28x70 (1982) Liberty		2002
New	28x40 1986 Fleetwood		2002
New	Rambler with Attached Garage		2002
New	One-story SFR with finished basement & deck		2002
New	Two-story SFR - 1997UBC		2002
New	20x50, 1968 Van Dyke		2002
New	2 story sfr w/ finished basement		2002
New	Two-story SFR with finished basement - 1997 UBC		2002
New	2 story sfr w/2 car garage		2002
New	Two Story SFR with Attached Garage and 756 Sq Ft Unfinished Basement		2002
New	2 story SFR with breezeway and attached garage and covered porch		2002
New	Rambler w/ Unfin Bsmt & 3 Car Garage		2002
New	2 story sfr w/finished basement & 2 car garage		2002
New	27 x 64 - 2000 Palm Harbor		2002
New	Approved Basic #99-115639 BP	Plan:1356 Two Story Duplex - 1997 UBC	2002
New	Two-story SFR with attached garage - 1997 UBC		2002
New	Rambler Style SFR - 1997 UBC		2002
New	Two Story SFR - 1997 UBC		2002
New	1 story SFR w/ attached garage		2002
New	28 x 66 2002 Golden West		2002
New	Approved Basic #98-110058BP	Plan #1214/2 OPTION Approved: alt. upper floor	2002
New	Two-story SFR		2002
New	Two-story SFR - 1997 UBC		2002
New	Approved Basic #02-109124 BP	Plan: 1214 SFR w/semi-finished lower floor - 1997	2002
New	Approved Basic #98-110058BP	Plan #1214/2 OPTION Approved: alt. upper floor	2002
New	Approved Basic #98-110058BP	Plan #1214/2 OPTION Approved: alt. upper floor	2002
New	24 x 50 1985 Fleetwood Mobile Home		2002
New	1978 Kozy 14x70 single wide		2002
New	832 sf Accessory Apt. w/280 sf attached carport & 246 sf covered deck/porch		2002
New	2 Story SFR w/ 2 Car		2002
New	2244sf two-story SRF with attached garage - 1997 UBC		2002
New	Split-level entry SFR - 1997 UBC		2002
New	Two Story SFR - 1997 UBC		2002
New	Split Level SFR with finished basement and attached garage		2002
New	OK to renew per Gloria Baker, 6/20/02 - jls 2 Story w/3 Car		2002
New	Two Story SFR w/unfinished basement - 1997 UBC		2002
New	Rambler Style SFR - 1997 UBC		2002
New	24 x 60 1977 Bayfront		2002
New	One-story SFR with unfinished basement (rough in only for laundry and future bathroom)		2002
New	2 story SFR with attached garage and covered porch		2002
New	Two Story SFR with 896 Sq Ft Unfinished Basement		2002
New	Daylight basement SFR w/ 2 Car		2002
New	2-Story SFR over daylight basement SFR w/attached garage & attached retaining wall		2002
New	2 story SFR with finished basement and attached garage		2002

Accessory Dwelling Units

Index # - File Name: 1.0022 - Single Family Dwellings Data\_Snohomish County.pdf

New	1488 rambler w/624 sf garage	2002
New	27 4 X 52 Redman 2002	2002
New	Rambler Style SFR - 1997 UBC	2002
New	One-story SFR w/attached garage	2002
New	3256 sf 2-story w/544 sf covered deck/porch, and 58 sf open decks	2002
New	Plans revised 4-5-04, approved by Alan Husby Rambler w/ Loft	2002
New	Approved Basic #00-108051 BP Plan: #1818/Getchell Rambler style SFR 1997 UBC	2002
New	Rambler style SFR w/attached garage.	2002
New	Move SFR form old location to this location with 1056 Sq Ft New Basement and 13 Square Rero	2002
New	Two Story SFR with Attached Garage	2002
New	One-story SFR w/attached garage	2002
New	27x66, 2002 Greenhill #466-3G	2002
New	One-story SFR w/attached garage	2002
New	2-story SFR w/unfinished basement.....1997 UBC	2002
New	Approved Basic #01-112026 BP Plan: 1220 Rambler Style SFR - 1997 UBC	2002
New	One-story SFR w/attached garage	2002
New	Approved Basic #01-111924 BP Rambler Style SFR - 1997 UBC	2002
New	Approved Basic #02-100878-BP Rambler Style SFR - 1997 UBC	2002
New	Approved Basic #02-100878-BP Rambler Style SFR - 1997 UBC	2002
New	Approved Basic #02-100878-BP Rambler Style SFR - 1997 UBC	2002
New	Approved Basic #02-105360 BP Plan: 1315 Mid Entry Split SFR- 1997 UBC	2002
New	1830 sf rambler w/528 sf garage. 09/27/02 No inspections to be done until FP permit is issued I	2002
New	2-Story SFR w/attached garage.	2002
New	Rambler with Attached Garage	2002
New	SFR Rambler w/ Unfin Basement & 2 Car Garage	2002
New	Rambler w/ 2 Car	2002
New	24 x 52 1985 - Brigadier Mansion	2002
New	Two Story SFR - 1997 UBC	2002
New	2576 sf SFR replacing & expanding burnt down SFR	2002
New	2 story SFR with attached garge	2002
New	40 -6 x 52 - 2003 - Golden West	2002
New	2-Story SFR w/covered porch	2002
New	Two Story SFR - 1997 UBC	2002
New	2 Story w/ 2 Car	2002
New	Rambler w/ 2 Car	2002
New	2000 27 x 66 Goldenwest - VillaWest	2002
New	SFR with Attached Garage	2002
New	2-Story SFR with semi-finished basement and attached garage.	2002
New	Rambler Style SFR - 1997 UBC	2002
New	Two-story SFR	2002
New	SFR w/attached garage	2002
New	Two Story SFR - 1997 UBC	2002
New	Detached Accessory Apartment - 1997 UBC	2002
New	One-story SFR with Attached Garage	2002
New	1990 Skyline Woodfield doublewide Application for expired permit No. 242588	2002
New	1120 rambler w/ garage and finished basement	2002
New	Rambler with Attached Garage	2002

Accessory Dwelling Units

Index # - File Name: 1.0022 - Single Family Dwellings Data\_Snohomish County.pdf

New	Approved Basic 02 100439 BP SFR w/finished basement - 1997 UBC	2002
New	Rambler style SFR with attached garage	2002
New	Two-story SFR w/attached garage	2002
New	24 x 44 - 1995 - Golden West.	2002
New	2-Story SFR w/attached garage over Daylight (203-fin. 849-unfin) Basement. ---->>> STOP WOR	2002
New	14 x 66 - 1986 - Fleetwood	2002
New	2620 sf 2-story w/550 sf garage and 240 sf covered deck/porch	2002
New	4800 Sq Ft Garage with 960 Sq Ft SFR on Second Floor	2002
New	Two-story SFR w/attached garage	2002
New	14 x 60 - 1975 - Paramount	2002
New	Two-story SFR	2002
New	Two-story Log SFR w/unfinished basement storage	2002
New	Two-story SFR w/basement	2002
New	2540sf SFR with 300sf loft for office space - 1997 UBC	2002
New	3 story SFR with unfinished basement and covered porch	2002
New	Two-story SFR - 1997 UBC	2002
New	39x60 Liberty KL286445 2000	2002
New	2 story sfr w/unfinished basement. Closed in error 2/13/04. Re-opened and OK for renewal. gt	2002
New	2-story w/unfinished basement, garage, covered deck/porch	2002
New	2002 Liberty 40 x 27	2002
New	Approved Basic #99-105399BP Plan: M2490C3F-0 Two Story SFR - 1997 UBC	2002
New	Rambler style SFR w/unfin. Basement & attached garage.	2002
New	SFR w/ attached Accessory Apartment - 1997 UBC	2002
New	Approved Basic #99-113971 BP Plan: 1315 Split Level SFR - 1997 UBC	2002
New	Two-story SFR w/garage in basement	2002
New	Rambler Style SFR - 1997 UBC	2002
New	2 story SFR with attached garage	2002
New	Two Story SFR with Basement	2002
New	Two-story SFR with daylight basement	2002
New	Rambler w/unfinished daylight basement....1997 UBC	2002
New	2 story SFR with covered porch	2002
New	28 x 48 2002 Oakwood	2002
New	Rambler style SFR with attached garage	2002
New	Two-story SFR - 1997 UBC Bldrs Plan: Rose 3	2002
New	Two-story SFR	2002
New	2064 s.f. w/1152 s.f. finished basement & 2 car garage	2002
New	Split-level entry SFR - 1997 UBC	2002
New	2001 24x44 Marlette	2002
New	28x66 1984 Ridgewood This application is to complete final inspection of expired permit no. 2	2002
New	Split level entry SFR - 1997 UBC	2002
New	2176 sf one-story SFR - 1997 UBC	2002
New	35 x 60 Accessory apartment and garage	2002
New	Two Story SFR - 1997 UBC. Finald permit with Dennis Meston s approval. Grading inspection v	2002
New	Rambler style SFR with attached garage	2002
New	Split level style SFR with fininshed basement	2002
New	Two Story SFR - 1997 UBC	2002
New	Two Story SFR w/storage area below - 1997 UBC	2002

Accessory Dwelling Units

Index # - File Name: 1.0022 - Single Family Dwellings Data\_Snohomish County.pdf

New	Accessory Apt on top of garage		2002
New	2 story SFR with attached garage		2002
New	28 X 44 Fleetwood LakePointe 2001		2002
New	Garage with living area above - 1997 UBC		2002
New	14 x 64 1976 Kentwood		2002
New	Rambler style SFR w/attached garage.		2002
New	2 story SFR with unfinished daylight basement		2002
New	Approved Basic #01-103343 BP	Plan: TS-2303 Two Story SFR ....1997 UBC	2002
New	1156 sf w/2710 sf garage and 314 sf covered deck/porch		2002
New	1144 sf rambler w/covered deck/porch		2002
New	Two-story SFR w/finished basement		2002
New	Two Story SFR		2002
New	28x56 Redman Ridgedale Classic 2001		2002
New	1712 s.f. sfr w/1187 s.f finished basement & 525 s.f. unfinished basement		2002
New	2 story SFR with attached garage		2002
New	Approved Basic #02-105360 BP	Plan: 1315 Mid Entry Split SFR - 1997 UBC	2002
New	1830 sf rambler w/528 sf garage		2002
New	2 story sfr w/3 car garage		2002
New	Approved Basic #02-100324-BP	Plan: 1396 Rambler style SFR - 1997 UBC	2002
New	Rambler with Attached Garage		2002
New	Rambler style SFR with attached garage		2002
New	Approved Basic #01-104109 BP	Plan: 1236 Mid Entry SFR - 1997 UBC	2002
New	Approved Basic #02-100324-BP	Plan: 1396 Rambler style SFR - 1997 UBC	2002
New	Approved Basic #01-104109 BP	Plan: 1236 Mid Entry SFR - 1997 UBC	2002
New	Approved Basic #02-100324-BP	Plan: 1396 Rambler style SFR - 1997 UBC	2002
New	Two Story SFR with Attached Garage		2002
New	SFR rambler style - 1997 UBC		2002
New	2-story SFR w/unfinished basement.....1997 UBC		2002
New	Approved Basic #01-103343 BP	Plan: TS-2303 Two Story SFR ....1997 UBC	2002
New	Approved Basic #01-103343 BP	Plan: TS-2303 Two Story SFR ....1997 UBC	2002
New	2-Story SFR w/attached garage.		2002
New	Two-story SFR - 1997 UBC		2002
New	Approved Basic #98-110058BP	Plan #1214/2 OPTION Approved: alt. upper floor	2002
New	2-Story SFR w/attached garage		2002
New	Approved Basic #99-113971 BP	Plan: 1315 Split Level SFR - 1997 UBC	2002
New	Rambler with Attached Garage		2002
New	2 Story w/ 3 Car		2002
New	Rambler with Attached Garage		2002
New	27x64 (2002) Palm Harbor 4P46409		2002
New	28 X 60 2003 Redman		2002
New	Rambler style SFR with attached garage and covered porch		2002
New	Approved Basic #02-108946 BP	Two Story SFR - 1997 UBC	2002
New	Rambler w/attached 3 Car Garage.		2002
New	2-story w/semi-finished basement, 421 sf garage & 300 sf open deck		2002
New	3038 sf 2-story w/888 sf garage & 32 sf covered porch		2002
New	Rambler style SFR w/loft.....1997 UBC		2002
New	Rambler Style SFR - 1997 UBC		2002

Accessory Dwelling Units

Index # - File Name: 1.0022 - Single Family Dwellings Data\_Snohomish County.pdf

New	SFR Rambler w/ 2 Car w/ unheated storage area above garage			2002
New	1740 sf Two-story SFR - 1997 UBC See Comments file in GR 03/16/2004 DKN			2002
New	Two-story SFR -- 1997 UBC			2002
New	One-story SFR/w attached garage			2002
New	Rambler style SFR....1997 UBC			2002
New	2 Story w/ 3 Car			2002
New	One-story SFR w/semi-finished basement			2002
New	Duplex split level enty - 1997 UBC			2002
New	1369sf rambler with attached garage - 1997 UBC			2002
New	SFR with semi-finished daylight basement - 1997UBC			2003
New	Split entry SFR with attached garage - 1997 UBC			2003
New	Rambler style SFR w/attached Garage. 20 psf snow load area			2003
New	One-story SFR with 2000sf unfinished basement with roughed-in plumbing - 1997UBC			2003
New	2-Story SFR w/attached garage - 1997 UBC			2003
New	Two-story SFR over garage - 1997 UBC LIZ BURNS HAS THE INSPECTOR PACKET - WAITING FOR			2003
New	2 Story SFR with attached garage & carport			2003
New	Rambler Style SFR - 1997 UBC			2003
New	Rambler w/ 3 Car			2003
New	2 Story w/ 4 Car Garage			2003
New	Two Story SFR - 1997 UBC			2003
New	Rambler w/ 3 Car - 1997 UBC			2003
New	Two-story SFR - 1997UBC			2003
New	One-story SFR w/semi-finished basement			2003
New	Two Story SFR with Semi Finished Basement and Attached Garage			2003
New	28 X 70 Redman 1983			2003
New	Rambler style SFR w/basement & garage			2003
New	2 Story w/ 2 Car			2003
New	New SFR w/attached garage			2003
New	Two-story SFR with attached garage-1997UBC			2003
New	1842sf rambler with 1010sf finished daylight basement - 1997UBC			2003
New	2 Story w/ 3 Car Garage			2003
New	28x71, 2003 Palm Harbor			2003
New	1924 Sq Ft Rambler with 1305 Sq Ft Attached Garage			2003
New	2-Story SFR over unfinished basement w/attached garage.			2003
New	2 story SFR with partial unfinished basement and attached garage			2003
New	2 story SFR with attached garage, covered porch and greenhouse			2003
New	Approved Basic #02-100324-BP Plan: 1396 Rambler style SFR - 1997 UBC	C		2003
New	Approved Basic #02-100324-BP Plan: 1396 Rambler style SFR - 1997 UBC	C		2003
New	Approved Basic #02-100324-BP Plan: 1396 Rambler style SFR - 1997 UBC	C		2003
New	Approved Basic #02-100324-BP Plan: 1396 Rambler style SFR - 1997 UBC	C		2003
New	Rambler Style SFR - 1997 UBC			2003
New	2-story w/ unfinished basement, attached garage			2003
New	2-story w/ garage			2003
New	2132sf Rambler with attached garage - 1997 UBC			2003
New	14x70, 1974 Governor			2003
New	Two Story SFR - 1997 UBC			2003
New	2-story SFR w/attached 3-car garage...1997 UBC			2003



Accessory Dwelling Units

Index # - File Name: 1.0022 - Single Family Dwellings Data\_Snohomish County.pdf

New	Two Story SFR - 1997 UBC		2003
New	Two-story SFR - 1997 UBC	Plan M3510A3S-0	2003
New	Two Story SFR - 1997 UBC		2003
New	2003 Palm Harbour 41 x 68`		2003
New	Two Story SFR with Attached Garage		2003
New	28x66 1978 Redman		2003
New	Rambler style SFR w/attached garage - 1997 UBC		2003
New	One-story SFR with semi-finished basement		2003
New	28 x 60 - 2003 - Silvercrest Clasic - Mobile Home.		2003
New	Two-story SFR - 1997 UBC		2003
New	Rambler style SFR with attached garage; covered porch and covered deck		2003
New	26 8 x52 (2003) Silver Crest Classic 45221		2003
New	One-story SFR w/basement		2003
New	27x53 (2003) Marlette		2003
New	850 sq. ft. detached accessory apartment - 1997 UBC		2003
New	Rambler style SFR		2003
New	One-story SFR with unfinished basement		2003
New	Rambler style SFR w/attached garage.		2003
New	Rambler Style SFR - 1997 UBC		2003
New	Rambler with Attached Garage - 1997 UBC		2003
New	Daylight Basement Rambler w/ 2 Car Garage		2003
New	771 s.f. sfr w/771 s.f. unfinished basement		2003
New	3360 sf 2-story w/garage		2003
New	Two-Story SFR - 1997UBC		2003
New	28x52, 1994 Guerdon		2003
New	One story SFR with 3 Car		2003
New	27x60 2001 Goldenwest		2003
New	One-story SFR w/attached garage		2003
New	2 story SFR with garage as main floor and living space on top		2003
New	Rambler Style SFR - 1997 UBC		2003
New	One-story SFR - 1997UBC		2003
New	Daylight Basement SFR w/attached garage & unfinished basement.		2003
New	14x66, 1995 Fleetwood Medford		2003
New	Two Story SFR - 1997 UBC	Plan Check Revision 12-23-03	2003
New	Approved Basic #01-104109 BP	Plan: 1236 Mid Entry SFR - 1997 UBC	2003
New	Approved Basic #01-104109 BP	Plan: 1236 Mid Entry SFR - 1997 UBC	2003
New	Approved Basic #01-104109 BP	Plan: 1236 Mid Entry SFR - 1997 UBC	2003
New	Two Story SFR - 1997 UBC		2003
New	2344 s.f. sfr w/703 s.f. unheated storage, 155 s.f. unheated sunroom, 3 car garage		2003
New	One-story SFR		2003
New	Split Entry style SFR w/finished basement and garage in basement.		2003
New	2-Story SFR w/attached garage.		2003
New	Two-story SFR - 1997UBC		2003
New	SFR with unfinished basement and attached garage - 1997 UBC		2003
New	SFR w/finished basement - 1997 UBC		2003
New	Two Story SFR - 1997 UBC		2003
New	27 x 56 Fleetwood 2003		2003

Accessory Dwelling Units

Index # - File Name: 1.0022 - Single Family Dwellings Data\_Snohomish County.pdf

New	Rambler style SFR w/attached garage and breezeway connecting to existing garage.	2003
New	2 story SFR with unfinished basement and attached garage	2003
New	Two-story SFR - 1997 UBC	2003
New	Approved Basic #03-100446 BP Plan: 2838 Two Story SFR - 1997 UBC	2003
New	Two Story SFR - 1997 UBC	2003
New	Converting 40 x 44 1998 Fuqua to permanent residence.	2003
New	2-story SFR w/attached garage.	2003
New	Two-story SFR - 1997 UBC	2003
New	26x60 (2003) Marlette	2003
New	Approved Basic #00-107111 BP Rambler style SFR.....1997 UBC	2003
New	27 x 44 2003 Fleetwood Lake Pointe	2003
New	Split entry style SFR w/finished basement-&-garage - 1997 UBC	2003
New	Two Story SFR w/unfinished basement - 1997 UBC	2003
New	27x44 2000 Redmond	2003
New	Two Story w/semi-finished basement - 1997 UBC	2003
New	Rambler Style SFR - 1997 UBC	2003
New	Two Story SFR - 1997 UBC	2003
New	Two story SFR with attached garage - 1997UBC	2003
New	Rambler w/ Daylight Fin Bsmt & Unfin Bsmt & 3 Car	2003
New	Rambler Style SFR - 1997 UBC	2003
New	Approved Basic #02-100878-BP Rambler Style SFR - 1997 UBC	2003
New	2-Story SFR w/attached garage.	2003
New	Two Story SFR with Attached Garage	2003
New	27x52, 2003 Rivercrest	2003
New	Two-story SFR	2003
New	Two Story SFR - 1997 UBC 20 psf snow load	2003
New	Rambler w/ Finished Basement & 2 Car Garage	2003
New	Rambler Style SFR with attached garage	2003
New	Rambler style SFR w/attached garage.	2003
New	One-story SFR w/finished basement - 1997 UBC	2003
New	1984 Barrington 56 x 28	2003
New	Two Story SFR - 1997 UBC	2003
New	Two Story SFR - 1997 UBC	2003
New	1678sf SFR with unfinished daylight basement - 1997 UBC	2003
New	1 story SFR w/heated storage area above garage - 1997 UBC	2003
New	1987 Fleetwood 56 x 14	2003
New	Approved Basic #03-108899 BP Two Story SFR - 1997 UBC	2003
New	2 Story w/ 3 Car Garage	2003
New	Rambler Style SFR - 1997 UBC	2003
New	Rambler style SFR with attached garage	2003
New	New 2 Story SFR w/attached garage	2003
New	Rambler with Attached Garage	2003
New	1972 Kentwood Princeton 24 x 32	2003
New	Rambler style SFR w/attached garage - 1997 UBC	2003
New	Two-story SFR w/finished basement	2003
New	27 x 52 - 2003 - Silvercrest	2003
New	Two Story SFR with Attached Garage - 1997 UBC	2003

Accessory Dwelling Units

Index # - File Name: 1.0022 - Single Family Dwellings Data\_Snohomish County.pdf

New	28 x 66 - 2003 - Karsten			2003
New	SFR w/ attached garage			2003
New	Single story SFR w/daylight basement & loft.....1997 UBC. OK to renew per N. Anderson, 9/9/0			2003
New	Two Story SFR - 1997 UBC			2003
New	Two Story SFR - 1997 UBC			2003
New	2-Story SFR w/attached garage.			2003
New	27x60 Double-wide Mobile Marlette Desert Manor 2003			2003
New	Approved Basic #02-109124 BP	Plan: 1214	SFR w/semi-finished lower floor - 1997	2003
New	Approved Basic #03-104023BP	Builders Plan 1699	Split Entry Style SFR	2003
New	Split Entry Style SFR - 1997 UBC			2003
New	27x66 (2003) Redmond			2003
New	2-story SFR w/garage			2003
New	Rambler Style SFR - 1997 UBC			2003
New	Rambler Style SFR - 1997 UBC			2003
New	Convert existing shop on property to a 848 sq ft Detached Apartment...1997 UBC			2003
New	26x44 (2003) Marlette			2003
New	26x44 (2003) Marlette			2003
New	One-story SFR			2003
New	Two Story SFR with Finished Basement			2003
New	Two-story SFR - 1997UBC			2003
New	2-Story SFR over finished basement w/attached garage - 1997 UBC			2003
New	Two Story SFR - 1997 UBC			2003
New	2-Story SFR over Unfinished Basement w/attached garage - 1997 UBC			2003
New	2-Story over finished daylight basement SFR			2003
New	24x40 2002 Marlett Limited			2003
New	2-story w/covered deck/porch			2003
New	Rambler style SFR - 1997 UBC			2003
New	Approved Basic #98-110213BP	Plan #1333	Two Story Duplex - 19	2003
New	Rambler Style SFR - 1997 UBC			2003
New	SFR with Basement and Attached Garage			2003
New	SFR w/finished basement & attached garage			2003
New	2003 Palm Harbor 71 x 27			2003
New	28x60, 1979 Radco			2003
New	Two Story SFR with Attached Garage			2003
New	Two Story SFR - 1997 UBC			2003
New	Rambler w/ 3 Car Garage			2003
New	Convert SFR & detached studio into duplex - 1997 UBC			2003
New	Two Story Duplex - 1997 UBC	Plan: GB 31		2003
New	Two Story SFR -1997 UBC			2003
New	Rambler style w/unfinished basement & garage - 1997 UBC			2003
New	2-Story SFR w/attached garage.			2003
New	Two Story SFR - 1997 UBC			2003
New	27 X 56 Fleetwood 2003			2003
New	Rambler Style SFR - 1997 UBC			2003
New	Two Story SFR w/unfinished basement - 1997 UBC			2003
New	Rambler Style SFR - 1997 UBC			2003
New	Two-story SFR - 1997 UBC			2003

Accessory Dwelling Units

Index # - File Name: 1.0022 - Single Family Dwellings Data\_Snohomish County.pdf

New	Two Story SFR - 1997 UBC	2003
New	28 x 64 1988 Fuqua	2003
New	Two-story SFR w/ attached garage with unheated storage area above garage 1997 UBC	2003
New	Detached Garage and Carport with Second Floor Recreation Room with Bath	2003
New	2-Story SFR	2003
New	Two-story SFR - 1997UBC	2003
New	41 x 66 Triple Wide 2004 Silvercrest	2003
New	24x50 1968 El Karr	2003
New	2-story w/finished basement & garage	2003
New	Rambler style SFR w/attached garage.	2003
New	Two-Story SFR - 1997 UBC	2003
New	28 x 60 Palm Harbor Mobile Home	2003
New	Two-story SFR with semi-finished basement - 1997 UBC	2003
New	Two-story SFR with unfinished basement - 1997 UBC	2003
New	60 X 40, 2003 Marlette	2003
New	Converting duplex to single family residence - 1997 UBC	2003
New	1980 24 x 52 Liberty Oakbrook	2003
New	Two-story SFR - 1997 UBC	2003
New	2 Story Rambler w/ fin daylight basement & 2 Car Garage	2003
New	Approved Basic #01-105979 BP Plan: 1680 Two Story Duplex - 1997 UBC	2003
New	Approved Basic #01-105979 BP Plan: 1680 Two Story Duplex - 1997 UBC	2003
New	2-story w/ garage & unfinished basement - 1997 UBC	2003
New	Two Story SFR with Finished Basement and Attached Garage	2003
New	1250 sq ft Rambler	2003
New	2-Story SFR over daylight basement SFR w/attached garage.	2003
New	Two Story SFR - 1997 UBC	2003
New	Approved Basic #02-109499 BP Plan: 1344 Split Level SFR - 1997 UBC	2003
New	Approved Basic #03-104070 BP Plan: 1677 Two-Story SFR - 1997 UBC	2003
New	Approved Basic #03-104070 BP Plan: 1677 Two-Story SFR - 1997 UBC	2003
New	Two-story SFR with 3-car garage - 1997 UBC	2003
New	Two Story SFR w/attached accessory apartment - 1997 UBC	2003
New	Two Story SFR - 1997 UBC	2003
New	Approved Basic #98-110231BP Plan: Rutledge 1365 One-story SFR w/finisl	2003
New	Approved Basic # 01-106966 BP Plan #1741 Two Story SFR - 1997 UBC 2001 E	2003
New	Two-story SFR	2003
New	2 Story w Covered Deck & Unfinished Basement	2003
New	2 story SFR w/ attached garage	2003
New	Accessory apartment over garage - 1997 UBC	2003
New	27x44, 1990 Champion Taharack	2003
New	Two-story Duplex - 1997UBC	2003
New	Rambler w/ unfinished daylight bsmt, unheated solarium & 2 Car Garage	2003
New	40 x 56 - 1993 - Marlette	2003
New	One-story SFR w/semi-finished basement	2003
New	40x52 2002 Waverly Crest XLE 7523F	2003
New	27x56, 2002 Greenbrier	2003
New	2 Story SFR with unfinished basement	2003
New	Two Story SFR - 1997 UBC	2003

Accessory Dwelling Units

Index # - File Name: 1.0022 - Single Family Dwellings Data\_Snohomish County.pdf

New	Two Story SFR - 1997 UBC		2003
New	Rambler Style SFR - 1997 UBC		2003
New	Converting 24x40 1978 Corinthian mobile home to guesthouse.		2003
New	2-Story SFR w/attached garage.		2003
New	2-story SFR over semi-finished daylight basement replacing existing mobile home.		2003
New	Two story SFR with attached garage		2003
New	40x66, 2000 Golden West Villa		2003
New	2-story SFR w/attached garage.		2003
New	Approved Basic #02-107746 BP	Plan: 1317 Duplex Two Story Duplex - 1997 UBC	2003
New	Approved Basic #03-100765 BP	Plan: 1704 Split Entry - 1997 UBC	2003
New	Split Level SFR - 1997 UBC		2003
New	Split Entry style SFR w/finished basement.		2003
New	Two-story SFR - 1997 UBC		2003
New	Two story SFR		2003
New	28x56, 2003 First Edition		2003
New	Two Story SFR - 1997 UBC		2003
New	Permit changed ownership from Scott Burke, 7/29/03. gb	2-story house w/unfinished daylight	2003
New	2002 Fleetwood 4684B 27 x 66		2003
New	Split level entry SFR - 1997UBC		2003
New	Split-level entry SFR - 1997UBC		2003
New	24x52, 1972 Allen Homes Bon Prix		2003
New	40x44, 2003 Pacifica #8221		2003
New	28 x 44 - 2003 - Skyline		2003
New	SFR w/semi-finished basement - 1997 UBC		2003
New	1362 rambler with attached garage - 1997UBC		2003
New	Two-story SFR		2003
New	2-story Duplex w/attached garages.		2003
New	26x66 1984 Glen River		2003
New	Two-story SFR w/finished basement		2003
New	28 x 64 - 1978 - Goldenwest-Sunnybrook		2003
New	2-story w/garage		2003
New	2 story SFR with attached carport		2003
New	2 Story SFR w/ 3 Car		2003
New	14x60, 1982 Homette		2003
New	Daylight Basement Rambler w/attached garage.		2003
New	Multi-level SFR w/ garage		2003
New	Two Story SFR - 1997 UBC		2003
New	Two story SFR with attached Garage/Bonus Room		2003
New	Garage/Shop with second floor office space - 1997 UBC		2003
New	Two Story SFR - 1997 UBC		2003
New	Rambler style SFR w/garage - 1997 UBC		2003
New	Rambler w/ garage - 1997 UBC		2003
New	Two-story SFR - 1997UBC replacing existing residence		2003
New	Two Story SFR w/unfinished basement - 1997 UBC		2003
New	Rambler Style SFR - 1997 UBC		2003
New	Two story SFR - 1997 UBC		2003
New	Two-story Duplex - 1997 UBC		2003

Accessory Dwelling Units

Index # - File Name: 1.0022 - Single Family Dwellings Data\_Snohomish County.pdf

New	Rambler Style SFR - 1997 UBC			2003
New	720 sf Accessory Apartment w/garage and covered deck			2003
New	27 x 66 - 2001 Oakwood			2003
New	SFR with Attached Garage - 1997 UBC			2003
New	2-story w/garage			2003
New	Two Story SFR - 1997 UBC			2003
New	Two-story log home with finished basement - 1997 UBC			2003
New	24 x 60 1968 Rex			2003
New	27x71, 2003 Palm Harbor			2003
New	Rambler style w/garage - 1997 UBC			2003
New	Rambler Style SFR - 1997 UBC			2003
New	Two Story SFR - 1997 UBC			2003
New	14 x 56 1980 Kozy Final supersedes previous Expired status A Husby 6/4/14 Expired without C			2003
New	Two Story SFR - 1997 UBC			2003
New	Two Story SFR - 1997 UBC			2003
New	Two Story SFR - 1997 UBC			2003
New	Approved Basic #01-111544 BP	Plan: 1008	Rambler Style SFR - 1997 UBC	( 2003
New	Approved Basic #01-111544 BP	Plan: 1008	Rambler Style SFR - 1997 UBC	( 2003
New	Approved Basic #03-102796 BP	Plan: 1307 - revised	Basement Rambler SFR - 199	2003
New	Rambler style w/ garage 20 psf snow load area			2003
New	Two story SFR			2003
New	Approved Basic # 03-101040 BP	Plan: Katie	Two Story SFR - 1997 UBC	2003
New	SFR with Attached Garage with Second Story Rec Room			2003
New	Two Story SFR - 1997 UBC			2003
New	Two Story SFR - 1997 UBC Okay to final permit with open flood hazard per Liz Burns on 02/08/C			2003
New	Rambler Style SFR - 1997 UBC			2003
New	2-Story over unfinished daylight basement w/attached garage.			2003
New	Two-story SFR w/finished basement - 1997 UBC			2003
New	Altering an existing SFR into upper & lower Duplex units. Permit transferred to M. Sullivan from			2003
New	2-story style SFR w/unfinished basement/storage & 3-car garage....1997 UBC			2003
New	Rambler Style SFR - 1997 UBC			2003
New	28x56 2003 Skyline 4146CT			2003
New	SFR with Unfinished Basement and Attached Garage			2003
New	Two-story SFR w/semi-finished basement Correction Notice 6/16/03 Must apply for a retaining			2003
New	One-story SFR - 1997 UBC			2003
New	Two Story SFR - 1997 UBC			2003
New	Two Story SFR w/unfinished basement - 1997 UBC			2003
New	740 sf Detached Accessory Apartment w/attached garage			2003
New	Approved Basic #99-109328BP	Plan: 8270	Two Story SFR - 1997 UBC	2003
New	Two Story SFR - 1997 UBC			2003
New	2 Story SFR with Bonus Room & 2 Car Garage			2003
New	Rambler Style SFR - 1997 UBC			2003
New	Two-story SFR with semi- & unfinished basement			2003
New	22 6 x 44 2003 Marlette			2003
New	Two-story SFR - 1997 UBC			2003
New	1680sf SFR with unfinished bonus room above garage - 1997UBC			2003
New	Two-story SFR - 1997 UBC			2003

Accessory Dwelling Units

Index # - File Name: 1.0022 - Single Family Dwellings Data\_Snohomish County.pdf

New	Two-story SFR - 1997 UBC		2003
New	Two-story SFR - 1997 UBC		2003
New	2 story SFR with attached garage		2003
New	2-Story SFR w/attached garage.		2003
New	Approved Basic #01-113672 BP	Plan: 2002 Two Story SFR - 1997 UBC	Op 2003
New	2-story w/garage and covered deck/porch	grading permit issuance is allowed for installation of	2003
New	Two-story Cabin		2003
New	Two Story SFR - 1997 UBC		2003
New	2-story SFR.....1997 UBC.	Wetaca Homes transferred permit to builder Darryl Peterson, 11/2	2003
New	Approved Basic #02-107764 BP	Plan # 7840-A w/Bonus Rm Two Story SFR - 1997 UBC	2003
New	Approved Basic #99-112337 BP	Plan: 7260 Two Story SFR - 1997 UBC	2003
New	Approved Basic #03-103472BP	Plan: 7365 Two Story SFR - 1997 UBC	2003
New	2-Story SFR w/attached garage		2003
New	Two Story SFR - 1997 UBC		2003
New	Approved Basic #01-105456 BP	Plan: 2650A-DB/3SG Two-story SFR w/unfinish	2003
New	Approved Basic #99-110420 BP	Plan 8230-A 2-Story SFR w/attached garage	2003
New	Approved Basic #02-108536 BP	Plan 7856 Two Story SFR - 1997 UBC	2003
New	2 story SFR with unfinished basement and attached garage		2003
New	Approved Basic #02-108745 BP	Plan: 7360 Two Story SFR - 1997 UBC	2003
New	One-story SFR with 1512sf finished daylight basement	4 bedrooms plus study	2003
New	Two-story SFR - 1997UBC		2003
New	65 4 X 26 8 Karsten 2003		2003
New	Convert existing 24 X 60 Golden West Mobile Home to 2 bedroom guesthouse.		2003
New	850sf detached accessory apartment with 720sf garage - 1997UBC		2003
New	Rambler Style SFR - 1997 UBC		2003
New	2446 Sq Ft SFR with 840 Sq Ft Finished Basement and 830 Sq Ft Attached Carport		2003
New	2-story SFR w/ garage & finished basement		2003
New	Rambler w/attached garage		2003
New	Rambler style SFR with attached garage		2003
New	56 X 24 Glsner 1978		2003
New	Rambler style SFR with attached garage		2003
New	Approved Basic #99-113971 BP	Plan: 1315 Split Level SFR - 1997 UBC	2003
New	Approved Basic #03-101983 BP	Plan: 1985 SFR w/finished lower floor - 1997	2003
New	Approved Basic #03-105182 BP	Plan: 1320 Two Story SFR - 1997 UBC	2003
New	Approved Basic #03-101983 BP	Plan: 1985 SFR w/finished lower floor - 1997	2003
New	Approved Basic #00-110871 BP	Plan: 556 Two Story SFR - 1997 UBC	2003
New	Approved Basic #00-110868 BP	Plan: 553 Two Story SFR - 1997 UBC	2003
New	2078 Sq Ft Rambler - 1997 UBC		2003
New	Rambler Style SFR - 1997 UBC		2003
New	Two Story SFR - 1997 UBC	Plan: 706	2003
New	Two Story SFR - 1997 UBC	Plan: 703	2003
New	27x71, 2002 Palm Harbor	On 1/6/05 Melissa Cavender changed to a Skyline 1252CT/6828 - see	2003
New	1988 Barrington 67x27		2003
New	2000 Fleetwood 67x24		2003
New	2-Story SFR w/attached garage - 1997 UBC		2003
New	2 Story w/ Finished Daylight Basement & 3 Car Garage		2003
New	2-Story Duplex w/attached double garages.		2003

Accessory Dwelling Units

Index # - File Name: 1.0022 - Single Family Dwellings Data\_Snohomish County.pdf

New	One-story SFR with daylight basement - 1997UBC		2003
New	2 Story w/ Daylight Unfinished Basement & 3 Car - 1997 UBC		2003
New	Two Story SFR - 1997 UBC		2003
New	Rambler with 2/ car & 2nd Floor Bonus Room		2003
New	Approved Basic #03-100749 BP	Plan - Jessica III Rambler Style SFR - 1997 UBC	2003
New	2-Story SFR w/attached garage.		2003
New	Approved Basic #03-105808 BP	Plan: 2450 Two-story SFR - 1997 UBC	2003
New	Two-story SFR		2003
New	Rambler Style SFR - 1997 UBC		2003
New	Two Story SFR - 1997 UBC		2003
New	Approved Basic #03-102539 BP	Plan: R3 T/S-2606 A Two-story SFR - 1997 UBC	2003
New	2 story SFR w/attached garage - 1997 UBC		2003
New	Two Story SFR with 1260 Sq Ft Unfinished Basement and Attached Garage		2003
New	Approved Basic 02-108967BP	Plan: R 3-2118 B Rambler Style SFR - 1997 UBC	2003
New	Rambler Style SFR - 1997 UBC		2003
New	Two-story SFR - 1997 UBC		2003
New	Approved Basic #03-100185 BP	Plan: R3/S-2118 B Rambler Style SFR - 1997 UBC	2003
New	2-story SFR w/semi-finished basement &/attached garage.		2003
New	Two Story SFR with Unfinished Basement and Attached Garage		2003
New	Approved Basic #00-101994 BP	Plan: 2330 Two Story SFR - 1997 UBC	2003
New	Approved Basic #98-150985BP	Plan # 5911E Two Story SFR - 1997 UBC	2003
New	Approved Basic #99-113246 BP	Plan: 2632 Two Story SFR - 1997 UBC	2003
New	Two Story SFR - 1997 UBC		2003
New	One-story SFR w/semi-finished basement		2003
New	Two Story SFR w/ attached garage - 1997 UBC		2003
New	2-Story SFR w/attached garage		2003
New	Approved Basic #00-100660 BP	Plan: 1803 Rambler Style SFR - 1997 UBC	2003
New	Approved Basic #00-100660 BP	Plan: 1803 Rambler Style SFR - 1997 UBC	2003
New	Approved Basic #02-110607-BP	. Plan: 1966 Rambler Style SFR - 1997 UBC	2003
New	Approved Basic #00-100660 BP	Plan: 1803 Rambler Style SFR - 1997 UBC	2003
New	Approved Basic #00-100660 BP	Plan: 1803 Rambler Style SFR - 1997 UBC	2003
New	Approved Basic #02-110607-BP	. Plan: 1966 Rambler Style SFR - 1997 UBC	2003
New	2-Story SFR w/attached garage.		2003
New	Rambler Style SFR - 1997 UBC		2003
New	Rambler Style SFR - 1997 UBC	Bldr s. Plan: 1914	2003
New	Two Story SFR - 1997 UBC		2003
New	2675sf 2-story w/898 sf garage		2003
New	Approved Basic #02-110607-BP	Plan: 1966 Rambler Style SFR - 1997 UBC	2003
New	Two-story SFR - 1997 UBC		2003
New	Approved Basic #03-100030 BP	Plan: 1307 SFR w/unfinished & partial finished base	2003
New	26 8 x 66 2002 Marlette Elation		2003
New	Two Story SFR - 1997 UBC		2003
New	Rambler w/garage		2003
New	2-Story SFR w/breezeway and attached garage with living space above.		2003
New	SFR w/finished basement - 1997 UBC		2003
New	Two Story SFR - 1997 UBC		2003
New	Two Story SFR with Attached Garage		2003



Accessory Dwelling Units

Index # - File Name: 1.0022 - Single Family Dwellings Data\_Snohomish County.pdf

New	Approved Basic #01-107312 BP	Plan: 1731	Two Story SFR - 1997 UBC	2003
New	Two Story SFR - 1997 UBC			2003
New	Approved Basic #01-112969 BP	Plan No. 2321	Mid-entry SFR - 1997 UBC	2003
New	Two Story SFR - 1997 UBC			2003
New	2-Story SFR w/attached garage.			2003
New	2-Story Duplex w/attached double garages.			2003
New	Daylight Rambler with attached garage			2003
New	Approved Basic #03-100030 BP	Plan: 1307	SFR w/partial finished & unfinished bas	2003
New	Approved Basic #03-102794 BP	Plan: 1966 - revised	Rambler Style SFR - 1997 UBC	2003
New	Approved Basic #03-100030 BP	Plan: 1307	SFR w/partial finished & unfinished bas	2003
New	Approved Basic #02-107151 BP	Plan: 2565-B	Two Story SFR - 1997 UBC	2003
New	Approved Basic #02-107151 BP	Plan: 2565-B	Two Story SFR - 1997 UBC	2003
New	Two Story SFR with Attached Garage - 1997 UBC			2003
New	Approved Basic #03-100749 BP	Plan - Jessica III	Rambler Style SFR - 1997 UBC	2003
New	Approved Basic #03-104592 BP	Plan 2003	Rambler Style SFR - 1997 UBC	2003
New	Approved Basic #03-100020 BP	Plan: 1549	Rambler Style SFR - 1997 UBC	2003
New	Two Story SFR - 1997 UBC			2003
New	Two-Story SFR - 1997 UBC	Plan: 2216		2003
New	Approved Basic #03-107307 BP	Plan 2317	Rambler Style SFR w/unfinished daylight	2003
New	Approved Basic #03-100483 BP	Plan: 1604	Rambler Style SFR - 1997 UBC	2003
New	Two- Story SFR - 1997 UBC	Plan: 2216		2003
New	Approved Basic #03-107307 BP	Plan 2317	Rambler Style SFR w/unfinished daylight	2003
New	Two Story SFR - 1997 UBC			2003
New	Approved Basic #00-100660 BP	Plan: 1803	Rambler Style SFR - 1997 UBC	2003
New	Approved Basic #00-104229 BP	Plan: 1533 revised	Two Story SFR - 1997 UBC	2003
New	Approved Basic #01-112901 BP	Plan 1962	Rambler style SFR - 1997 UBC	2003
New	Approved Basic #02-110314 BP	Plan: 2281-3	Rambler Style SFR - 1997 UBC	2003
New	Approved Basic #03-102794 BP	Plan: 1966 - revised	Rambler Style SFR - 1997 UBC	2003
New	Approved Basic #03-108705 BP	Plan #2009	Two Story SFR - 1997 UBC	2003
New	Approved Basic #02-110429 BP	Plan 2600	Tri-Level Tri-Level SFR - 1997 UBC	2003
New	Two story SFR w/unfinished basement - 1997 UBC			2003
New	1570 s.f. rambler w/2 car garage/shop			2003
New	576 sf studio style living space w/ attached garage and unheated 2nd floor storage			2003
New	Two-story SFR - 1997 UBC	Bldrs Plan 5039AM		2003
New	Approved Basic #01-110907 BP		Two Story SFR - 1997 UBC	2003
New	2 Story w/ Attached Garage			2003
New	Rambler style SFR w/attached garage.			2003
New	Two-story SFR - 1997 UBC	Plan 5039AM		2003
New	Two Story SFR - 1997 UBC			2003
New	One-story SFR w/attached garage			2003
New	Two-story SFR with 4-car garage - 1997 UBC			2003
New	2-Story SFR w/attached garage.			2003
New	Two-story SFR with 760 sf finished basement - 1997 UBC			2003
New	Approved Basic #03-105996 BP	Plan: 2833	Two Story SFR - 1997 UBC	2003
New	Two Story SFR - 1997 UBC			2003
New	Approved Basic #03-102854-BP	Plan: 2472 w/bonus	Two Story SFR - 1997 UBC	2003
New	Approved Basic #03-105993 BP	Plan: 3272	Two Story SFR - 1997 UBC	2003

Accessory Dwelling Units

Index # - File Name: 1.0022 - Single Family Dwellings Data\_Snohomish County.pdf

New	Two Story SFR with Attached Garage		2003
New	Two Story w/semi-finished basement - 1997 UBC		2003
New	Approved Basic #03-105993 BP	Plan: 3272 Two Story SFR - 1997 UBC	2003
New	Two-story SFR - 1997 UBC	Plan: 2984	2003
New	One-story SFR w/attached garage		2003
New	2-Story SFR over unfinished daylight basement w/attached garage		2003
New	Rambler w/unfinished basement & garage		2003
New	2-story SFR		2003
New	Approved Basic 02 110429 BP	Plan 2600 Tri-Level Tri-Level SFR - 1997 UBC	2003
New	Approved Basic #02-110422BP	Plan 2500 Rambler-style SFR - 1997UBC	2003
New	Approved Basic #02-102061 BP	Plan: 2010 Rambler Rambler Style SFR - 1997 UBC	2003
New	Approved Basic #02-110422BP	Plan 2500 Rambler-style SFR - 1997UBC	2003
New	Approved Basic #02-102061 BP	Plan: 2010 Rambler Rambler Style SFR - 1997 UBC	2003
New	Approved Basic #02-110422BP	Plan 2500 Rambler-style SFR - 1997UBC	2003
New	Approved Basic #02-110429 BP	Plan 2600 Tri-Level Tri-Level SFR - 1997 UBC	2003
New	Approved Basic #02-110422BP	Plan 2500 Rambler-style SFR - 1997UBC	2003
New	2256sf rambler with attached garage - 1997UBC		2003
New	1843 rambler w/garage		2003
New	Approved Basic #03-102794 BP	Plan: 1966 - revised Rambler Style SFR - 1997 UBC	2003
New	1008 SF SFR		2003
New	2-story SFR w/attached garage.		2003
New	Approved Basic #03-101867BP	Two Story SFR - 1997 UBC	2003
New	Two-story SFR - 1997 UBC		2003
New	2-Story SFR w/attached Garage.		2003
New	2-story w/ garage		2003
New	Approved Basic #01-111603 BP	Bldrs Plan 2968 Two-story style SFR.....1997 UBC	2003
New	Approved Basic #01-101541 BP	Plan: 2877 Two Story SFR - 1997 UBC	2003
New	Approved Basic #98-150633BP	Plan: 2555 Two Story SFR - 1997 UBC	2003
New	2-story w/ garage and unfinished basement		2003
New	Two Story SFR - 1997 UBC		2003
New	Two-story style SFR....1997 UBC	Plan: 3175	2003
New	Two Story SFR - 1997 UBC	Plan: 2588	2003
New	Approved Basic #01-107346 BP	Plan: SSI 2783 Two Story SFR - 1997 UBC	2003
New	Two-story SFR - 1997UBC		2003
New	Approved Basic #01-111603 BP	Bldrs Plan 2968 Two-story style SFR.....1997 UBC	2003
New	Approved Basic #03-105191 BP	Plan: 2783 Two Story SFR - 1997 UBC	2003
New	Approved Basic #01-101544 BP	Plan: 2611 (51 2656) Two Story SFR - 1997 UBC	2003
New	Approved Basic #01-101541BP	Plan: 2877 Two Story SFR - 1997 UBC	2003
New	Approved Basic #99-109495 BP	Plan: 2771 Two Story SFR - 1997 U	2003
New	Approved Basic #01-111603 BP	Bldrs Plan 2968 Two-story style SFR.....1997 UBC	2003
New	Approved Basic #01-107346 BP	Plan: SSI 2783 Two Story SFR - 1997 UBC	2003
New	Approved Basic #03-105191 BP	Plan: 2783 Two Story SFR - 1997 UBC	2003
New	Approved Basic #98-150632BP	Plan: 45 er Two Story SFR - 1997	2003
New	Approved Basic #01-111493 BP	Bldr Plan SSI 2727 Two-story style SFR.....1997 UBC	2003
New	28x60 1978 Fleetwood		2003
New	Rambler Style SFR - 1997 UBC		2003
New	Tri-Level SFR with Attached Garage		2003

Accessory Dwelling Units

Index # - File Name: 1.0022 - Single Family Dwellings Data\_Snohomish County.pdf

New	Rambler style SFR w/attached garage & covered porch.		2003	
New	Approved Basic #03-105447 BP	Plan: 2222	Two-story SFR w/finished basement....1997	2003
New	28 x 56		2003 Skyline	2003
New	Rambler w/ unfinished Basement			2003
New	SFR Rambler w/ 3 Car - 1997 UBC			2003
New	26 8 x66		2002 Marlette Elation	2003
New	SFR 1830 sf		w/garage	2003
New	Two Story SFR with Attached Garage			2003
New	Approved Basic #02-109499 BP	Plan: 1344	Split Level SFR - 1997 UBC	2003
New	Approved Basic #01-103343 BP	Plan: TS-2303	Two Story SFR ....1997 UBC	2003
New	Approved Basic #03-104593 BP	Plan: 2058	Rambler Style SFR - 1997 UBC	2003
New	26 8 x66		2002 Marlette Elation	2003
New	Two Story SFR w/Unfinished Basement - 1997 UBC			2003
New	28 x 60		- 2003 - Karsten	2003
New	SFR w/walk out bsmt & 2nd story loft - 1997 UBC			2003
New	Two-story SFR - 1997UBC			2003
New	2-Story SFR w/attached garage & Covered porch - 1997 UBC			2003
New	Two Story w/unfinished basement - 1997 UBC			2003
New	2 story SFR with attached garage			2003
New	Daylight Basement style Rambler w/attached garage.			2003
New	Two Story SFR with Attached Garage			2003
New	2 story SFR with unfinished basement and attached garage			2003
New	Daylight basement SFR w/attached garage. Per Dwayne Overhosler, agreed to provide ftg and			2003
New	Two-story SFR			2003
New	Two Story SFR - 1997 UBC			2003
New	Rambler w/ garage - 1997 UBC			2003
New	Approved Basic #03-104791BP	Plan: Getchell	Rambler Style SFR - 1997 UBC	2003
New	Two-story SFR - 1997 UBC			2003
New	2003 Fleetwood 27 x 68			2003
New	Two Story SFR with Attached Garage			2003
New	Two-story SFR - 1997 UBC			2003
New	Two-story SFR - 1997 UBC			2003
New	2 story SFR w/unfinished basement & attached garage			2003
New	Approved Basic #98-116988BP	Option Approved:	Main floor plan layout 2 story s	2003
New	2 Story 2/ Finished Basement - 1997 UBC			2003
New	2-story SFR w/finished basement....1997 UBC			2003
New	Approved Basic #03-108441 BP	Plan 2276	Two-Story SFR w/finished baseme	2003
New	2 story SFR with crow s nest	See Comments	file to right 08/16/2004 DKN	2003
New	Two-story SFR - 1997UBC			2003
New	2 story sfr w/2 car garage			2003
New	2-story w/garage		*SEE COMMENTS	2003
New	2-Story SFR w/attached garage.			2003
New	2002 sf rambler - 1997UBC			2003
New	2-story w/garage			2003
New	Rambler style SFR with attached garage			2003
New	2 story SFR w/attached 3 car garage			2003
New	Approved Basic #02-109607 BP	Plan #2265 C/2-3	Two Story SFR - 1997 UBC	2003

Accessory Dwelling Units

Index # - File Name: 1.0022 - Single Family Dwellings Data\_Snohomish County.pdf

New	Approved Basic #03-104048 BP	Plan: 2493	Two-story SFR w/attached garage	2003
New	2-Story SFR w/attached garage.			2003
New	Approved Basic #02-104896 BP	Plan 2274	Rambler Style SFR -1997 UBC	2003
New	Approved Basic #03-105966 BP	Plan 2952	Two Story SFR - 1997 UBC	2003
New	Approved Basic 03 109545 BP	Plan: M2535A3F-25	Two Story SFR - 1997 UBC	2003
New	Approved Basic 03 109545 BP	Plan: M2535A3F-25	Two Story SFR - 1997 UBC	2003
New	Approved Basic 03-106696-BP	Plan 2760	Two Story SFR - 1997 UBC	2003
New	Two-story SFR - 1997UBC			2003
New	One-story SFR - 1997UBC			2003
New	Two-story SFR			2003
New	2-story w/ garage			2003
New	Rambler style SFR w/attached garage.			2003
New	1-story w/ finished basement & garage			2003
New	Two Story SFR - 1997 UBC			2003
New	One-story SFR			2003
New	Approved Basic #02-109607 BP	Plan #2265 C/2-3	Two Story SFR - 1997 UBC	2003
New	Two-story SFR - 1997 UBC			2003
New	Two-story SFR - 1997 UBC			2003
New	Two Story SFR - 1997 UBC			2003
New	2-story SFR w/garage			2003
New	Two Story SFR - 1997 UBC			2003
New	Two Story SFR with Attached Garage			2003
New	Approved Basic #03-104264 BP	Plan: 2815	Two Story SFR - 1997 UBC	2003
New	Approved Basic #03-103351 BP	Plan: 0122	Two-story SFR - 1997UBC	2003
New	Two-story SFR - 1997UBC			2003
New	2354sf Rambler - 1997UBC			2003
New	Approved Basic #03-101554 BP	Plan 0305	Two-story SFR - 1997 UBC	2003
New	Two Story SFR w/semi-finished basement - 1997 UBC			2003
New	One-story SFR with finished basement - 1997 UBC			2003
New	2 story SFr w/attached garage- 1997 UBC			2003
New	Approved Basic #03-102911-BP	Plan: 2195	Split Entry SFR - 1997 UBC	2003
New	Approved Basic #03-105182 BP	Plan: 1320	Two Story SFR - 1997 UBC	2003
New	Approved Basic #03-102911-BP	Plan: 2195	Split Entry SFR - 1997 UBC	2003
New	Tri-Level w/garage			2003
New	2-story w/garage			2003
New	Approved Basic #03-101983 BP	Plan: 1985	SFR w/finished lower floor - 1997	2003
New	Approved Basic #03-10291-BP	Plan: 2195	Split Entry SFR - 1997 UBC	2003
New	Approved Basic #03-101983 BP	Plan: 1985	SFR w/finished lower floor - 1997	2003
New	Split Entry Style SFR w/basement garage.			2003
New	Approved Basic #03-102744 BP	Plan: 1482 front load	Two Story SFR - 1997 UBC	2003
New	Approved Basic #03-102744 BP	Plan: 1482 front load	Two Story SFR - 1997 UBC	2003
New	Approved Basic #03-102744 BP	Plan: 1482 front load	Two Story SFR - 1997 UBC	2003
New	SFR with Finished Basement and Attached Garage			2003
New	Rambler with Attached Garage			2003
New	Two Story SFR - 1997 UBC			2003
New	Approved Basic #03-105182 BP	Plan: 1320	Two Story SFR - 1997 UBC	2003
New	Approved Basic #03-102740 BP	Plan: 1482 side load	Two Story SFR - 1997 UBC	2003

Accessory Dwelling Units

Index # - File Name: 1.0022 - Single Family Dwellings Data\_Snohomish County.pdf

New	Approved Basic #03-102733 BP	Plan: 1040 Rambler Style SFR - 1997 UBC	2003
New	Approved Basic #03-102733 BP	Plan: 1040 Rambler Style SFR - 1997 UBC	2003
New	Approved Basic #03-102740 BP	Plan: 1482 side load Two Story SFR - 1997 UBC	2003
New	Approved Basic #03-102911-BP	Plan: 2195 Split Entry SFR - 1997 UBC	2003
New	Approved Basic #03-101106 BP	Plan: Lopez Two Story SFR - 1997 UBC	2003
New	Approved Basic #03-101106 BP	Plan: Lopez Two Story SFR - 1997 UBC	2003
New	Approved Basic #03-101010 BP	Plan: San Juan Two Story SFR - 1997 UBC	2003
New	Approved Basic #03 101400 BP	Plan: Whidbey/side entry Two Story SFR - 1997 UBC	2003
New	Approved Basic #03-101010 BP	Plan: San Juan Two Story SFR - 1997 UBC	2003
New	Approved Basic #03 101400 BP	Plan: Whidbey/side entry Two Story SFR - 1997 UBC	2003
New	Two-story SFR - 1997UBC		2003
New	Approved Basic #03-102421 BP	Plan: 1725 B Two Story SFR - 1997 UBC	2003
New	Approved Basic #03-101155 BP	Plan #2188 side load Two Story SFR - 1997 UBC	2003
New	Approved Basic #03-101155 BP	Plan #2188 side load Two Story SFR - 1997 UBC	2003
New	Two Story SFR - 1997 UBC	Plan: Jefferson Bay A	2003
New	Two Story SFR - 1997 UBC	Plan: Jefferson Bay B	2003
New	Approved Basic #03-101155 BP	Plan #2188 side load Two Story SFR - 1997 UBC	2003
New	Approved Basic #03-101159 BP	Plan: 2127 - side load Two Story SFR - 1997 UBC	2003
New	Approved Basic #03-101159 BP	Plan: 2127 - side load Two Story SFR - 1997 UBC	2003
New	Approved Basic #02-109374 BP	Plan: 2407 SFR w/finished lower floor - 1997 UBC	2003
New	Approved Basic #02-109375 BP	Plan: 2294 Two Story SFR - 1997 UBC	2003
New	2 story sfr w/basement & attached garage		2003
New	Approved Basic #02-108384 BP	Plan: 2598 A Two Story SFR - 1997 UBC	2003
New	Two Story SFR - 1997 UBC		2003
New	Approved Basic #02-104896 BP	Plan 2274 Rambler Style SFR -1997 UBC	2003
New	2-Story SFR w/attached garage.		2003
New	2-Story SFR w/attached garage.		2003
New	Two Story SFR - 1997 UBC	Plan: 2535	2003
New	One-story SFR w/attached garage		2003
New	One-story SFR w/attached garage		2003
New	Two Story SFR - 1997 UBC		2003
New	Rambler w/ 3 Car Garage		2003
New	Approved Basic #03-105966 BP	Plan 2952 Two Story SFR - 1997 UBC	2003
New	Two Story SFR - 1997 UBC		2003
New	Approved Basic #02-104896 BP	Plan 2274 Rambler Style SFR -1997 UBC	2003
New	Approved Basic 03-106696-BP	Plan 2760 Two Story SFR - 1997 UBC	2003
New	Approved Basic #03-103337 BP	Plan: 2409 A Two Story SFR - 1997 UBC	2003
New	Approved Basic #03-107891 BP	Plan: 2300 A Two Story SFR - 1997 UBC	2003
New	Approved Basic #02-109074 BP	Plan: 1740 Two Story SFR - 1997 UBC	2003
New	Approved Basic #03-107891 BP	Plan: 2300 A Two Story SFR - 1997 UBC	2003
New	Approved Basic #02-109074 BP	Plan: 1740 Two Story SFR - 1997 UBC	2003
New	Approved Basic #02-108384 BP	Plan: 2598 A Two Story SFR - 1997 UBC	2003
New	Approved Basic #03-103339 BP	Plan: 2042 A Two Story SFR - 1997 UBC	2003
New	Approved Basic #03-103337 BP	Plan: 2409 A Two Story SFR - 1997 UBC	2003
New	Approved Basic #02-109074 BP	Plan: 1740 Two Story SFR - 1997 UBC	2003
New	Approved Basic #02-108383 BP	Plan: 2409 C Two Story SFR - 1997 UBC	2003
New	Approved Basic #02-108384 BP	Plan: 2598 A Two Story SFR - 1997 UBC	2003

Accessory Dwelling Units

Index # - File Name: 1.0022 - Single Family Dwellings Data\_Snohomish County.pdf

New	Approved Basic #02-109074 BP	Plan: 1740 Two Story SFR - 1997 UBC	2003
New	Approved Basic #02-108383 BP	Plan: 2409 C Two Story SFR - 1997 UBC	2003
New	Approved Basic #02-108383 BP	Plan: 2409 C Two Story SFR - 1997 UBC	2003
New	Approved Basic #02-108384 BP	Plan: 2598 A Two Story SFR - 1997 UBC	2003
New	Approved Basic #02-109074 BP	Plan: 1740 Two Story SFR - 1997 UBC	2003
New	Approved Basic #02-108383 BP	Plan: 2409 C Two Story SFR - 1997 UBC	2003
New	Approved Basic #02-108385 BP	Plan: 2042 C Two Story SFR - 1997 UBC	2003
New	Approved Basic #02-108383 BP	Plan: 2409 C Two Story SFR - 1997 UBC	2003
New	Approved Basic #02-109074 BP	Plan: 1740 Two Story SFR - 1997 UBC	2003
New	Approved Basic #03-103339 BP	Plan: 2042 A Two Story SFR - 1997 UBC	2003
New	Approved Basic #02-108385 BP	Plan: 2042 C Two Story SFR - 1997 UBC	2003
New	Approved Basic #02-108383 BP	Plan: 2409 C Two Story SFR - 1997 UBC	2003
New	Approved Basic #02-109074 BP	Plan: 1740 Two Story SFR - 1997 UBC	2003
New	Approved Basic #02-108385 BP	Plan: 2042 C Two Story SFR - 1997 UBC	2003
New	Approved Basic #03-103340 BP	Plan: 2598 B Two Story SFR - 1997 UBC	2003
New	Approved Basic #01-110518 BP	Plan: 1587 SFR w/finished lower floor - 1997 UBC	2003
New	Approved Basic #01-112969 BP	Plan No. 2321 Mid-entry SFR - 1997 UBC	2003
New	Two Story Duplex - 1997 UBC		2003
New	Two-story SFR - 1997 UBC		2003
New	Rambler Style SFR - 1997 UBC		2003
New	27 x 66 Palm Harbor 2003		2003
New	27x52, 2003 Liberty		2003
New	Two Story SFR - 1997 UBC		2003
New	Two Story SFR - 1997 UBC		2003
New	SFR w/finished basement - 1997 UBC		2003
New	2-Story SFR w/attached garage		2003
New	982sf SFR with 870sf finished daylight basement with roughed-in plumbing - 1997UBC		2003
New	Rambler w/ 2 Car & Covered Deck		2003
New	2-Story SFR w/attached garage.		2003
New	New SFR w/finished daylight basement & attached garage		2003
New	2-Story SFR w/attached garage.		2003
New	Two Story SFR - 1997 UBC		2003
New	Two Story SFR - 1997 UBC		2003
New	Two Story SFR - 1997 UBC		2003
New	Two Story SFR - 1997 UBC	Plan #3151	2003
New	Approved Basic #03-108122 BP	Plan # 3259-3 Two Story SFR - 1997 UBC	2003
New	Approved Basic #03-104235 BP	Plan: 3151 Two Story SFR - 1997 UBC	2003
New	2-Story SFR w/attached garage.		2003
New	Approved Basic #03-107261 BP	Plan: 1292 Rambler Style SFR - 1997 UBC	2003
New	Approved Basic #03-105495 BP	Plan: 1482 front load (SSI) Two Story SFR - 1997 U	2003
New	Approved Basic #03-105654 BP	Plan: 1040 Alternate Joists Rambler Style SFR - 1997	2003
New	Approved Basic #03-105654 BP	Plan: 1040 Alternate Joists Rambler Style SFR - 1997	2003
New	Approved Basic #03-105495 BP	Plan: 1482 front load Two Story SFR - 1997 UBC	2003
New	Approved Basic #03-105495 BP	Plan: 1482 front load Two Story SFR - 1997 UBC	2003
New	Two Story SFR - 1997 UBC	Plan #2117	2003
New	Approved Basic #03-101982 BP	Plan No. 2119 Two Story SFR - 1997 UBC	2003
New	Approved Basic #03-101980 BP	Plan No. 1786 Two Story SFR - 1997 UBC	2003

Accessory Dwelling Units

Index # - File Name: 1.0022 - Single Family Dwellings Data\_Snohomish County.pdf

New	Approved Basic #03-101983 BP	Plan: 1985	SFR w/finished lower floor - 1997	2003
New	1538sf rambler - 1997 UBC	Plan 1538		2003
New	Approved Basic #03-101981 BP	Plan: 2471	Two-story style SFR.....1997 U	2003
New	Approved Basic #03-101981 BP	Plan: 2471	Two-story style SFR.....1997	2003
New	Approved Basic #03-101980 BP	Plan No. 1786	Two Story SFR - 1997 UBC	2003
New	Approved Basic #03-101980 BP	Plan: 1786	Two Story SFR - 1997 UBC	2003
New	Approved Basic #03-101978 BP	Plan No. 2360	Two Story SFR - 1997 UBC	2003
New	Approved Basic #03-101981 BP	Plan: 2471	Two-story style SFR.....1997 U	2003
New	Approved Basic #03-101980 BP	Plan No. 1786	Two Story SFR - 1997 UBC	2003
New	Approved Basic #03-101982 BP	Plan No. 2119	Two Story SFR - 1997 UBC	2003
New	Approved Basic #03-101978 BP	Plan No. 2360	Two Story SFR - 1997 UBC	2003
New	Approved Basic #03-101978 BP	Plan No. 2360	Two Story SFR - 1997 UBC	2003
New	Approved Basic #03-101982 BP	Plan No. 2119	Two Story SFR - 1997 UBC	2003
New	Approved Basic #03-101978 BP	Plan No. 2360	Two Story SFR - 1997 UBC	2003
New	Approved Basic #03-107261 BP	Plan: 1292	Rambler Style SFR - 1997 UBC	2003
New	Approved Basic #03-105497 BP	Plan: 1482 end load	Two Story SFR - 1997 UBC	2003
New	Rambler Style SFR - 1997 UBC			2003
New	Approved Basic #03-102733 BP	Plan: 1040	Rambler Style SFR - 1997 UBC	2003
New	Approved Basic #03-102744 BP	Plan: 1482 front load (Split Entry)	Two Story SFR - 19	2003
New	Approved Basic #03-102733 BP	Plan: 1040	Rambler Style SFR - 1997 UBC	2003
New	Approved Basic #03-107261 BP	Plan: 1292	Rambler Style SFR - 1997 UBC	2003
New	Approved Basic #03-105495 BP	Plan: 1482 front load	Two Story SFR - 1997 UBC	2003
New	Approved Basic #03-103826 BP	Plan: 1906	Two Story SFR - 1997 UBC	2003
New	Approved Basic #01-108242 BP	Plan No. 1896	2-story style SFR....1997 UBC	2003
New	Approved Basic #02-109483 BP	Plan: 1839	Two Story SFR - 1997 UBC	2003
New	Approved Basic #02-108690-BP	Plan: 1677	Rambler Style SFR - 1997 UBC	2003
New	Approved Basic #03-103826 BP	Plan: 1906	Two Story SFR - 1997 UBC	2003
New	Approved Basic #01-108242 BP	Plan No. 1896	Two Story SFR....1997 UBC	2003
New	Approved Basic #03-103826 BP	Plan: 1906	Two Story SFR - 1997 UBC	2003
New	Approved Basic #02-100055 BP	Plan: 1615	Two Story SFR -1997 UBC	2003
New	Approved Basic #02-109483 BP	Plan: 1839	Two Story SFR - 1997 UBC	2003
New	Approved Basic #01-108242 BP	Plan No. 1896	2-story style SFR....1997 UBC	2003
New	Approved Basic #02-108689-BP	Plan: 2002	Rambler Style SFR - 1997 UBC	2003
New	Approved Basic #02-109483 BP	Plan: 1839	Two Story SFR - 1997 UBC	2003
New	Approved Basic #02-108689-BP	Plan: 2002	Rambler Style SFR - 1997 UBC	2003
New	Approved Basic #02-109483 BP	Plan: 1839	Two Story SFR - 1997 UBC	2003
New	Approved Basic #02-100055 BP	Plan: 1615	Two Story SFR -1997 UBC	2003
New	Two Story SFR - 1997 UBC			2003
New	Approved Basic #02-108690-BP	Plan: 1677	Rambler Style SFR - 1997 UBC	2003
New	SFR w/garage PERMIT RENEWED 1/5/05 Sandy Sullivan			2003
New	Two Story SFR with Attached Garage			2003
New	2 Story w/ 3 Car			2003
New	Two Story SFR - 1997 UBC			2003
New	Two Story SFR - 1997 UBC			2003
New	Two Story SFR - 1997 UBC			2003
New	Two-story SFR - 1997UBC Plan 2864			2003
New	Approved Basic #03-109166 BP	Plan: 3236	Two Story SFR - 1997 UBC	2003

Accessory Dwelling Units

Index # - File Name: 1.0022 - Single Family Dwellings Data\_Snohomish County.pdf

New	Two Story SFR - 1997 UBC	Plan: Tate	2003
New	Approved Basic #01-103742 BP	Plan: Patrick Rambler Style SFR - 1997 UBC	2003
New	Two Story SFR - 1997 UBC	Plan: Camden	2003
New	Two Story SFR - 1997 UBC	Plan: Amber	2003
New	Two Story SFR - 1997 UBC	Plan: Amber	2003
New	Two Story SFR - 1997 UBC	Plan: Clairborne	2003
New	Two Story SFR - 1997 UBC	Plan: Camden	2003
New	Two Story SFR - 1997 UBC	Plan: Sterling	2003
New	Two Story SFR - 1997 UBC	Plan: Sterling	2003
New	Approved Basic #01-103742 BP	Plan: Patrick Rambler Style SFR - 1997 UBC	2003
New	Two Story SFR - 1997 UBC	Plan: Evergreen	2003
New	Two Story SFR - 1997 UBC	Plan: Taylor	2003
New	Two Story SFR - 1997 UBC	Plan: Clairborne	2003
New	Approved Basic #01-103744 BP	Plan: Willow Two Style SFR - 1997 UBC	2003
New	Two Story SFR - 1997 UBC	Plan: Sterling	2003
New	Approved Basic #01-103742 BP	Plan: Patrick Rambler Style SFR - 1997 UBC	2003
New	Approved Basic #01-103740 BP	Plan: Aspen Rambler Style SFR - 1997 UBC	2003
New	26x56 (2002) Marlette		2003
New	26x52 (2002) Marlette		2003
New	Approved Basic #03-109166-BP	Plan: 3236 Two Story SFR - 1997 UBC	2003
New	Approved Basic #03-108122 BP	Plan # 3259-3 Two Story SFR - 1997 UBC	2003
New	Approved Basic #03-104236 BP	Plan: 3046 Two Story SFR - 1997 UBC	2003
New	Approved Basic #03-1033561 BP	Plan: 2224 A Two Story SFR - 1997 UBC	2003
New	2-story w/finished basement and garage		2003
New	40 x 70 2003 Palm Harbor		2003
New	Rambler styler SFR w/attached breezeway/carport.		2003
New	Approved Basic #03-104593 BP	Plan: 2058 Rambler Style SFR -1997 UBC	2003
New	2-Story SFR over finished daylight basement + w/attached garage.		2003
New	Two-story SFR - 1997 UBC		2003
New	2 Story w/ 2 Car		2003
New	2 Story w/ 3 Car		2003
New	Two Story SFR - 1997 UBC		2003
New	2 story SFR w/attached garage	Plan #2817	2003
New	2 story SFR w/attached garage	Plan #3142	2003
New	Two Story SFR - 1997 UBC		2003
New	Approved Basic #03-103265 BP	Plan: 2817 Two Story SFR - 1997 UBC	2003
New	Approved Basic #03-104906 BP	Plan #3210 Side Two Story SFR - 1997 UBC	2003
New	Approved Basic #03-104911 BP	Plan #3105 Two Story SFR - 1997 UBC	2003
New	Two-story SFR - 1997 UBC	Plan 1683	2003
New	Two-story SFR - 1997 UBC	Plan 1677	2003
New	Two Story SFR - 1997 UBC	Plan: 1792 - Bump	2003
New	Two Story SFR - 1997 UBC	Plan: 1792	2003
New	Two Story SFR - 1997 UBC	Plan: 1673 -T	2003
New	Rambler Style SFR - 1997 UBC	Plan #1522	2003
New	Rambler Style SFR - 1997 UBC	Plan #1447	2003
New	Approved Basic #03-104418 BP	Plan: 1522 Rambler Style SFR - 1997 UBC	2003
New	Approved Basic #03-104421 BP	Plan: 1447 Rambler Style SFR - 1997 UBC	2003



Accessory Dwelling Units

Index # - File Name: 1.0022 - Single Family Dwellings Data\_Snohomish County.pdf

New	Approved Basic #02-100273 BP	Plan: 2117 Split Level SFR - 1997 UBC	Opti	2003
New	Approved Basic #02-100274 BP	Plan: 1710 Two Story SFR - 1997 UBC	Option	2003
New	Approved Basic #02-109388 BP	Plan: 1575 Tri-Level SFR - 1997 UBC	Opt	2003
New	Approved Basic #02-100273 BP	Plan: 2117 Split Level SFR - 1997 UBC	Opti	2003
New	Approved Basic #02-109388 BP	Plan: 1575 Tri-Level SFR - 1997 UBC	Opt	2003
New	Approved Basic #02-100274 BP	Plan: 1710 Two Story SFR - 1997 UBC	Option	2003
New	Approved Basic #02-100273 BP	Plan: 2117 Split Level SFR - 1997 UBC	Opti	2003
New	Approved Basic #02-100274 BP	Plan: 1710 Two Story SFR - 1997 UBC	Option	2003
New	Approved Basic #02-109388 BP	Plan: 1575 Tri-Level SFR - 1997 UBC	Opt	2003
New	Approved Basic #02-100274 BP	Plan: 1710 Two Story SFR - 1997 UBC	Option	2003
New	Approved Basic #02-100273 BP	Plan: 2117 Split Level SFR - 1997 UBC	Opti	2003
New	Approved Basic #02-100274 BP	Plan: 1710 Two Story SFR - 1997 UBC	Option	2003
New	2-story w/ garage			2003
New	2-Story SFR w/attached garage			2003
New	Approved Basic #03-102218 BP	Two Story SFR - 1997 UBC		2003
New	Approved Basic 99-115181BP	Plan: 1199 (wood) Rambler Style SFR - 1997 UB		2003
New	Approved Basic #03-104579 BP	Plan: 1339 Rambler Style SFR - 1997 UBC		2003
New	Approved Basic 99-115181BP	Plan: 1199 (wood) Rambler Style SFR - 1997 UB		2003
New	Approved Basic #00-103622 BP	Plan: 1399 (slab) Rambler Style SFR - 1997 UBC		2003
New	Approved Basic #01-112384 BP	Plan: 1253 slab (Elev B) Rambler Style SFR - 199		2003
New	Approved Basic #03-104579 BP	Plan: 1339 Rambler Style SFR - 1997 UBC		2003
New	Approved Basic #03-104579 BP	Plan: 1339 Rambler Style SFR - 1997 UBC		2003
New	Approved Basic #00-103622 BP	Plan: 1399 (slab) Rambler Style SFR - 1997 UBC		2003
New	Approved Basic #01-112384 BP	Plan: 1253 slab (Elev B) Rambler Style SFR - 199		2003
New	Approved Basic #00-103622 BP	Plan: 1399 (slab) Rambler Style SFR - 1997 UBC		2003
New	Approved Basic #00-103622 BP	Plan: 1399 (slab) Rambler Style SFR - 1997 UBC		2003
New	Approved Basic #00-103622 BP	Plan: 1399 (slab) Rambler Style SFR - 1997 UBC		2003
New	Approved Basic #03-104579 BP	Plan: 1339 Rambler Style SFR - 1997 UBC		2003
New	Approved Basic #03-104579 BP	Plan: 1339 Rambler Style SFR - 1997 UBC		2003
New	Approved Basic #03-104579 BP	Plan: 1339 Rambler Style SFR - 1997 UBC		2003
New	Approved Basic #01-112384 BP	Plan: 1253 slab (Elev B) Rambler Style SFR - 199		2003
New	Approved Basic #00-103622 BP	Plan: 1399 (slab) Rambler Style SFR - 1997 UBC		2003
New	Approved Basic #01-112384 BP	Plan: 1253 slab (Elev B) Rambler Style SFR - 199		2003
New	Approved Basic #03-104579 BP	Plan: 1339 Rambler Style SFR - 1997 UBC		2003
New	Approved Basic #00-103622 BP	Plan: 1399 (slab) Rambler Style SFR - 1997 UBC		2003
New	Rambler Style SFR - 1997 UBC	Plan: 1339		2003
New	Approved Basic #01-112384 BP	Plan: 1253 slab (Elev B) Rambler Style SFR - 199		2003
New	Approved Basic #00-103621 BP	Plan: 1199 (slab) Rambler Style SFR - 1997 UB		2003
New	Approved Basic #01-112384 BP	Plan: 1253 slab (Elev B) Rambler Style SFR - 199		2003
New	Approved Basic #00-103621 BP	Plan: 1199 (slab) Rambler Style SFR - 1997 UB		2003
New	Approved Basic #00-103622 BP	Plan: 1399 (slab) Rambler Style SFR - 1997 UBC		2003
New	Approved Basic #01-112384 BP	Plan: 1253 slab (Elev B) Rambler Style SFR - 199		2003
New	Approved Basic #03-104579 BP	Plan: 1339 Rambler Style SFR - 1997 UBC		2003
New	Approved Basic #00-103621 BP	Plan: 1199 (slab) Rambler Style SFR - 1997 UB		2003
New	Approved Basic #01-112384 BP	Plan: 1253 slab (Elev B) Rambler Style SFR - 199		2003
New	Approved Basic #00-103622 BP	Plan: 1399 (slab) Rambler Style SFR - 1997 UBC		2003
New	Approved Basic #00-103621 BP	Plan: 1199 (slab) Rambler Style SFR - 1997 UB		2003

Accessory Dwelling Units

Index # - File Name: 1.0022 - Single Family Dwellings Data\_Snohomish County.pdf

New	Approved Basic #00-103621 BP	Plan: 1199 (slab) Rambler Style SFR - 1997 UBC	2003
New	Approved Basic #00-103622 BP	Plan: 1399 (slab) Rambler Style SFR - 1997 UBC	2003
New	Approved Basic #00-103622 BP	Plan: 1399 (slab) Rambler Style SFR - 1997 UBC	2003
New	Approved Basic #00-103622 BP	Plan: 1399 (slab) Rambler Style SFR - 1997 UBC	2003
New	Approved Basic #01-112384 BP	Plan: 1253 slab (Elev B) Rambler Style SFR - 1997 UBC	2003
New	Approved Basic #00-103622 BP	Plan: 1399 (slab) Rambler Style SFR - 1997 UBC	2003
New	Two Story SFR - 1997 UBC	Plan: 1793 Gable	2003
New	Approved Basic 03-106658BP	Plan: 1793 Two Story Two-story SFR - 1997UBC	2003
New	Approved Basic 03-106658BP	Plan: 1793 Two Story Two-story SFR - 1997UBC	2003
New	Approved Basic 03-106658BP	Plan: 1793 Two Story Two-story SFR - 1997UBC	2003
New	Approved Basic 03-106658BP	Plan: 1793 Two Story Two-story SFR - 1997UBC	2003
New	Approved Basic 03-106658BP	Plan: 1793 Two Story Two-story SFR - 1997UBC	2003
New	Approved Basic 03-106658BP	Plan: 1793 Two Story Two-story SFR - 1997UBC	2003
New	Approved Basic 03-106658BP	Plan: 1793 Two Story Two-story SFR - 1997UBC	2003
New	Approved Basic #00-103621 BP	Plan: 1199 (slab) Rambler Style SFR - 1997 UB	2003
New	Mid Entry SFR - 1997 UBC	Plan: 2089	2003
New	Approved Basic 03-106674BP	Plan 2089 Mid-Entry Mid-Entry SFR - 1997 UBC	2003
New	Approved Basic 03-106674BP	Plan 2089 Mid-Entry Mid-Entry SFR - 1997 UBC	2003
New	Approved Basic 03-106674BP	Plan 2089 Mid-Entry Mid-Entry SFR - 1997 UBC	2003
New	Approved Basic 03-106674BP	Plan 2089 Mid-Entry Mid-Entry SFR - 1997 UBC	2003
New	Approved Basic 03-106674BP	Plan 2089 Mid-Entry Mid-Entry SFR - 1997 UBC	2003
New	Approved Basic 03-106674BP	Plan 2089 Mid-Entry Mid-Entry SFR - 1997 UBC	2003
New	Approved Basic 03-106674BP	Plan 2089 Mid-Entry Mid-Entry SFR - 1997 UBC	2003
New	Approved Basic 03-106674BP	Plan 2089 Mid-Entry Mid-Entry SFR - 1997 UBC	2003
New	Approved Basic 03-106674BP	Plan 2089 Mid-Entry Mid-Entry SFR - 1997 UBC	2003
New	Approved Basic 03-106674BP	Plan 2089 Mid-Entry Mid-Entry SFR - 1997 UBC	2003
New	Approved Basic 03-106674BP	Plan 2089 Mid-Entry Mid-Entry SFR - 1997 UBC	2003
New	Approved Basic 03-106674BP	Plan 2089 Mid-Entry Mid-Entry SFR - 1997 UBC	2003
New	Approved Basic 03-106658BP	Plan: 1793 Two Story Two-story SFR - 1997UBC	2003
New	Approved Basic 03-106674BP	Plan 2089 Mid-Entry Mid-Entry SFR - 1997 UBC	2003
New	Approved Basic 03-106674BP	Plan 2089 Mid-Entry Mid-Entry SFR - 1997 UBC	2003
New	Approved Basic 03-106674BP	Plan 2089 Mid-Entry Mid-Entry SFR - 1997 UBC	2003
New	Approved Basic 03-106674BP	Plan 2089 Mid-Entry Mid-Entry SFR - 1997 UBC	2003
New	Approved Basic 03-106674BP	Plan 2089 Mid-Entry Mid-Entry SFR - 1997 UBC	2003
New	Approved Basic 03-106674BP	Plan 2089 Mid-Entry Mid-Entry SFR - 1997 UBC	2003
New	Approved Basic 03-106658BP	Plan: 1793 Two Story Two-story SFR - 1997UBC	2003
New	Approved Basic 03-106658BP	Plan: 1793 Two Story Two-story SFR - 1997UBC	2003
New	Approved Basic 03-106658BP	Plan: 1793 Two Story Two-story SFR - 1997UBC	2003
New	Approved Basic #01-112384 BP	Plan: 1253 slab (Elev B) Rambler Style SFR - 1997 UBC	2003
New	Approved Basic #00-103622 BP	Plan: 1399 (slab) Rambler Style SFR - 1997 UBC	2003
New	Approved Basic #01-112384 BP	Plan: 1253 slab (Elev B) Rambler Style SFR - 1997 UBC	2003
New	Approved Basic #03-104579 BP	Plan: 1339 Rambler Style SFR - 1997 UBC	2003
New	Approved Basic #00-103622 BP	Plan: 1399 (slab) Rambler Style SFR - 1997 UBC	2003
New	Approved Basic #00-103622 BP	Plan: 1399 (slab) Rambler Style SFR - 1997 UBC	2003
New	Approved Basic #00-103622 BP	Plan: 1399 (slab) Rambler Style SFR - 1997 UBC	2003
New	Approved Basic 99-115181BP	Plan: 1199 (wood) Rambler Style SFR - 1997 UB	2003
New	Approved Basic #03-104579 BP	Plan: 1339 Rambler Style SFR - 1997 UBC	2003
New	Approved Basic #01-112384 BP	Plan: 1253 slab (Elev B) Rambler Style SFR - 1997 UBC	2003
New	Two Story SFR - 1997 UBC		2003
New	Approved Basic #03-101483 BP	Plan: 1674-B-3 Two Story SFR - 1997 UBC	2003
New	Approved Basic #03-104321 BP	Plan: 2300 B Two Story SFR - 1997 UBC	2003
New	Approved Basic #03-106887 BP	Plan: Columbia B Two-story SFR - 1997 UBC	2003

Accessory Dwelling Units

Index # - File Name: 1.0022 - Single Family Dwellings Data\_Snohomish County.pdf

New	Two-story SFR - 1997 UBC	Plan 1703.3 w/Bonus Room	2003
New	Approved Basic #03-105161 BP	Plan: Pilchuck Two Story SFR - 1997 UBC	2003
New	Rambler Style SFR - 1997 UBC		2003
New	Approved Basic #03-101483 BP	Plan: 1674-B-3 Rambler Style SFR - 1997 UBC	2003
New	Approved Basic #03-105172 BP	Plan: Skagit BG Two Story SFR - 1997 UBC	2003
New	Approved Basic #03-104321 BP	Plan: 2300 B Two Story SFR - 1997 UBC	2003
New	Approved Basic #03-104321 BP	Plan: 2300 B Two Story SFR - 1997 UBC	2003
New	Two Story SFR - 1997 UBC	Plan: 2300 B	2003
New	Approved Basic #03-104321 BP	Plan: 2300 B Two Story SFR - 1997 UBC	2003
New	One-story SFR - 1997UBC	Plan: Eagle One	2003
New	Two Story SFR - 1997 UBC	Plan: Columbia B	2003
New	Two Story SFR - 1997 UBC	Plan: Columbia B	2003
New	Two Story SFR - 1997 UBC	Plan: Columbia B	2003
New	Approved Basic #03-104321 BP	Plan: 2300 B Two Story SFR - 1997 UBC	2003
New	Approved Basic #03-104321 BP	Plan: 2300 B Two Story SFR - 1997 UBC	2003
New	Approved Basic #03-105161 BP	Plan: Pilchuck Two Story SFR - 1997 UBC	2003
New	Approved Basic #03-104321 BP	Plan: 2300 B Two Story SFR - 1997 UBC	2003
New	Approved Basic #03-106887 BP	Plan: Columbia B Two Story SFR - 1997 UBC	2003
New	Two Story SFR - 1997 UBC		2003
New	SFR w/garage & finished basement		2003
New	SFR w/finished basement and attached garage	Plan #1339 Daylight	2003
New	Approved Basic #03-106965 BP	Plan: 1339 Daylight SFR w/finished basement - :	2003
New	Approved Basic #03-104579 BP	Plan: 1339 Rambler Style SFR - 1997 UBC	2003
New	SFR w/finished basement and attache garage	Plan #1266 Daylight	2003
New	Approved Basic #03-106965 BP	Plan: 1339 Daylight SFR w/finished basement - :	2003
New	Two Story SFR - 1997 UBC		2003
New	Approved Basic #01-111402 BP	Plan: 1680-revised engineering Two-Story style SFR..	2003
New	Approved Basic #01-105212 BP	Plan: 1538 Two Story SFR - 1997 UBC	2003
New	Approved Basic #01-106982 BP	Plan: 1705 crawl (revised) SFR w/finished lo	2003
New	Approved Basic #01-111402 BP	Plan: 1680-revised engineering Two-Story style SFR..	2003
New	Approved Basic #02-100273 BP	Plan: 2117 Split Level SFR - 1997 UBC Opti	2003
New	Approved Basic #02-100274 BP	Plan: 1710 Two Story SFR - 1997 UBC Option	2003
New	Approved Basic #02-100273 BP	Plan: 2117 Split Level SFR - 1997 UBC Opti	2003
New	Approved Basic #01-105212 BP	Plan: 1538 Two Story SFR - 1997 UBC	2003
New	Approved Basic #03-104676 BP	Plan: 1680 w/basement Two Story SFR w/finished ba	2003
New	Approved Basic #03-106608 BP	Plan: 1538 Bsmt Two Story SFR w/finished basemer	2003
New	Approved Basic #03-105143 BP	Plan # J2060 Two Story SFR - 1997 UBC	2003
New	Approved Basic #01-106982 BP	Plan: 1705 crawl (revised) SFR w/finished lo	2003
New	Approved Basic #02-100830 BP	Plan: 1686 Split Level SFR - 1997 UBC	2003
New	Approved Basic #01-106982 BP	Plan: 1705 crawl (revised) SFR w/finished lo	2003
New	Approved Basic #02-100830 BP	Plan: 1686 Split Level SFR - 1997 UBC	2003
New	Approved Basic #01-106982 BP	Plan: 1705 crawl (revised) SFR w/finished lo	2003
New	Approved Basic #03-101064 BP	Plan: 1733 Two Story SFR - 1997 UBC	2003
New	Approved Basic #02-109388 BP	Plan: 1575 Tri-Level SFR - 1997 UBC Opt	2003
New	Approved Basic #01-111402BP	Plan:1680-revised engineering Two Story style SFR -	2003
New	Approved Basic #03-110686 BP	Plan: 1680 w/basement & 5 piece bath Two Story w/finis	2003
New	Two Story SFR w/finished basement - 1997 UBC		2003

Accessory Dwelling Units

Index # - File Name: 1.0022 - Single Family Dwellings Data\_Snohomish County.pdf

New	Approved Basic #03-104676 BP	Plan: 1680 w/basement	Two Story SFR w/finished b	2003
New	Approved Basic #02-109386 BP	Plan: 1710 Basement	Two Story SFR w/finished b	2003
New	Approved Basic #02-109386 BP	Plan: 1710 Basement	Two Story SFR w/finished b	2003
New	Approved Basic #03-104676 BP	Plan: 1680 w/basement	Two Story SFR w/finished b	2003
New	Approved Basic #03-106608 BP	Plan: 1538 Bsmt	Two Story SFR w/finished basemer	2003
New	Approved Basic #03-106608 BP	Plan: 1538 Bsmt	Two Story SFR - 1997 UBC	2003
New	Approved Basic #03-104676 BP	Plan: 1680 w/basement	Two Story SFR w/finished b	2003
New	Approved Basic #02-102531 BP	Plan: 1478	Two Story SFR - 1997 UBC C	2003
New	Approved Basic #03-102744 BP	Plan: 1482 front load (Split Entry)	Two Story SFR	2003
New	Approved Basic #03-105497 BP	Plan: 1482 end load	Two Story SFR - 1997 UBC	2003
New	Approved Basic #03-105495 BP	Plan: 1482 front load (SSI)	Two Story SFR - 1997 U	2003
New	Approved Basic #03-104676 BP	Plan: 1680 w/basement	Two Story SFR w/finished b	2003
New	Approved Basic #03-106608 BP	Plan: 1538 Bsmt	Two Story SFR w/finished basemer	2003
New	Approved Basic #03-106608 BP	Plan: 1538 Bsmt	Two Story SFR w/finished basemer	2003
New	Approved Basic #02-109124 BP	Plan: 1214	SFR w/semi-finished lower floor - 1997	2003
New	27x68 2003 Fleetwood 4684B with 308sf pod			2003
New	Rambler w/garage - 1997 UBC			2003
New	41 x 66 2003 Oakwood 7664Q			2003
New	Two Story SFR with Attached Garage			2003
New	Rambler Style SFR - 1997 UBC			2003
New	1330 Sq Ft Garage with 1050 Sq Ft Second Story SFR			2003
New	Two Story SFR - 1997 UBC	Plan: 5022 FB-B		2003
New	Two Story SFR - 1997 UBC	Plan: 4008 B-L		2003
New	Two Story SFR - 1997 UBC	Plan: 1010D-B-LX		2003
New	Two Story SFR - 1997 UBC	Plan: 5022-C		2003
New	Two Story SFR - 1997 UBC	Plan: 4008-A-L		2003
New	Two Story SFR - 1997 UBC	Plan: 4020 B-B-LG		2003
New	Two Story SFR - 1997 UBC	Plan: 5022 BF		2003
New	Two Story SFR - 1997 UBC	Plan: 4010 DB-C		2003
New	Two Story SFR - 1997 UBC	Plan: 4111		2003
New	Two Story SFR - 1997 UBC	Plan: 4008 B		2003
New	Two Story SFR - 1997 UBC	Plan: 3012		2003
New	Two Story SFR - 1997 UBC	Plan: 4002 B-A		2003
New	Two Story SFR - 1997 UBC	Plan: 3012-B-RG		2003
New	Two Story SFR - 1997 UBC	Plan: 4020-A-LX		2003
New	Two Story SFR - 1997 UBC	Plan: 4002 B-C-RXD		2003
New	Two Story SFR - 1997 UBC	Plan: 3-11 C-RG		2003
New	Two Story SFR - 1997 UBC	Plan: 4111 B-RX		2003
New	Two Story SFR - 1997 UBC	Plan: 4002B- A-RXD		2003
New	Two Story SFR - 1997 UBC	Plan: 3012 A-RG		2003
New	Two Story SFR - 1997 UBC	Plan: 5022 F-B-R		2003
New	Two Story SFR - 1997 UBC	Plan: 4008-A-RG		2003
New	Two Story SFR - 1997 UBC	Plan: 5022 FB-C-R		2003
New	Two Story SFR - 1997 UBC	Plan: 4010-DB-C-RG		2003
New	Two Story SFR - 1997 UBC	Plan: 5022 FB-B-R		2003
New	Approved Basic #03-105272 BP	Plan: 2571	Two Story SFR - 1997 UBC	2003
New	Approved Basic #03-105131 BP	Plan: 2130	Two Story SFR - 1997 UBC	2003

Accessory Dwelling Units

Index # - File Name: 1.0022 - Single Family Dwellings Data\_Snohomish County.pdf

New	Approved Basic #03-105131 BP	Plan: 2130	Two Story SFR - 1997 UBC	2003
New	Two Story SFR - 1997 UBC	Plan: 2571		2003
New	Approved Basic #03-105272 BP	Plan: 2571	Two Story SFR - 1997 UBC	2003
New	Approved Basic #98-150961 BP	Plan: 2203-3	Two Story SFR - 1997 UBC	2003
New	Approved Basic #98-150959BP		Two Story SFR w/unfinished basement - 1997 UBC	2003
New	Approved Basic #03-105987 BP	Plan: 2143	Two Story SFR w/finished basement -	2003
New	Two Story SFR w/finished basement - 1997 UBC	Plan: 2143		2003
New	Approved Basic #99-103777BP	Plan: 2415 A/3	Two Story SFR - 1997 UBC	2003
New	Approved Basic #98-150961 BP	Plan: 2203-3	Two Story SFR - 1997 UBC	2003
New	Two Story SFR - 1997 UBC			2003
New	Two Story SFR - 1997 UBC	Plan: 2130		2003
New	Two Story SFR - 1997 UBC	Plan: 2414		2003
New	Approved Basic #02-107090 BP	Plan: 2294	Two Story SFR - 1997 UBC	2003
New	Approved Basic #02-107917 BP	Plan: 2415	Two Story SFR - 1997 UBC	2003
New	Approved Basic #02-107917 BP	Plan: 2415	Two Story SFR - 1997 UBC	2003
New	27 x 56 Skyline Mobile Home.			2003
New	28x60, 2002 Redmond			2003
New	Rambler w/finished basement - 1997 UBC			2003
New	2 Story Duplex with 2 Car Garages			2003
New	Rambler Style SFR - 1997 UBC			2003
New	Approved Basic #03-108822 BP	Plan: 110293	Two Story SFR - 1997 UBC	2003
New	Two Story SFR - 1997 UBC	Plan: 1395 Hip		2003
New	Basic #03-106578 BP	Plan: 1395 G	Two Story SFR - 1997 UBC	2003
New	Basic #03-106577 BP	Plan: 1395 H	Two Story SFR - 1997 UBC	2003
New	Basic #03-106578 BP	Plan: 1395 G	Two Story SFR - 1997 UBC	2003
New	Basic #03-106577 BP	Plan: 1395 H	Two Story SFR - 1997 UBC	2003
New	Two Story SFR - 1997 UBC	Plan: 1395 Gable		2003
New	Approved Basic #03-101348 BP	Plan: 0222	SFR w/finished basement - 1997 UI	2003
New	Approved Basic #03-101348 BP	Plan: 0222	SFR w/finished basement - 1997 UI	2003
New	Approved Basic #00-108551 BP	Plan: 2127 w/basement	Two Story SFR w/finishec	2003
New	Approved Basic #03-100832 BP	Plan: 2390	Two Story SFR - 1997 UBC	2003
New	Two-story SFR - 1997 UBC	Plan: 2472		2003
New	Two Story SFR - 1997 UBC	Plan: 2504		2003
New	Two Story SFR - 1997 UBC	Plan: 2956		2003
New	2 story SFR with attached garage and covered porch			2003
New	Approved Basic #03-101148 BP	Plan: Amherst II/2472	Two-story SFR - 1997 UBC	2003
New	Approved Basic #03-100268 BP	Plan: 2591	Two Story SFR - 1997 UBC	2003
New	Approved Basic #03-100268 BP	Plan: 2591	Two Story SFR - 1997 UBC	2003
New	Approved Basic #03-101148 BP	Plan: Amherst II/2472	Two-story SFR - 1997 UBC	2003
New	Approved Basic #02-109632 BP	Plan: 2591	Two Story SFR - 1997 UBC	2003
New	Approved Basic #02-110641BP	Plan: 2300	Two-story SFR - 1997 UBC	2003
New	Two-story SFR - 1997 UBC	Plan M2450A3F-0		2003
New	Two-story SFR - 1997 UBC	Plan M3040A4F-1		2003
New	Two-story SFR - 1997 UBC	Plan M2400A3F-0		2003
New	Approved Basic #02-109388 BP	Plan: 1575	Tri-Level SFR - 1997 UBC	Option 2003
New	Approved Basic #01-111402 BP	Plan: 1680-revised engineering	Two-Story style SFR..	2003
New	Approved Basic #02-100274 BP	Plan: 1710	Two Story SFR - 1997 UBC	Option 2003

Accessory Dwelling Units

Index # - File Name: 1.0022 - Single Family Dwellings Data\_Snohomish County.pdf

New	Approved Basic #02-100273 BP	Plan: 2117 Split Level SFR - 1997 UBC	Opti	2003
New	Approved Basic #02-100274 BP	Plan: 1710 Two Story SFR - 1997 UBC	Option	2003
New	Approved Basic #02-100831 BP	Plan: 1755 Split Level SFR - 1997 UBC		2003
New	Approved Basic #03-106612 BP	Plan: 2117 Bsmt. Two Story SFR w/finished baseme		2003
New	Approved Basic #02-109386 BP	Plan: 1710 Basement Two Story SFR w/finished b		2003
New	Approved Basic #01-105212 BP	Plan: 1538 Two Story SFR - 1997 UBC		2003
New	Approved Basic #02-100273 BP	Plan: 2117 Split Level SFR - 1997 UBC	Opti	2003
New	Approved Basic #02-100274 BP	Plan: 1710 Two Story SFR - 1997 UBC	Option	2003
New	Approved Basic #02-100273 BP	Plan: 2117 Split Level SFR - 1997 UBC	Opti	2003
New	Approved Basic #02-100274 BP	Plan: 1710 Two Story SFR - 1997 UBC	Option	2003
New	Approved Basic #01-106982 BP	Plan: 1705 crawl (revised) SFR w/finished lo		2003
New	Approved Basic #02-100273 BP	Plan: 2117 Split Level SFR - 1997 UBC	Opti	2003
New	Approved Basic #02-100274 BP	Plan: 1710 Two Story SFR - 1997 UBC	Option	2003
New	Approved Basic #02-100832 BP	Plan: 1455 Split Level SFR - 1997 UBC		2003
New	Approved Basic #02-100273 BP	Plan: 2117 Split Level SFR - 1997 UBC	Opti	2003
New	Approved Basic #02-109388 BP	Plan: 1575 Tri-Level SFR - 1997 UBC	Opt	2003
New	Approved Basic #02-100832 BP	Plan: 1455 Split Level SFR - 1997 UBC		2003
New	Two Story SFR w/finished basement - 1997 UBC	Plan: 2117 BSM		2003
New	Approved Basic #02-109386 BP	Plan: 1710 Basement Two Story SFR w/finished b		2003
New	Approved Basic #02-109386 BP	Plan: 1710 Basement Two Story SFR w/finished b		2003
New	Approved Basic #03-110686 BP	Plan: 1680 w/basement & 5 piece bath Two Story SF		2003
New	Approved Basic #02-100274 BP	Plan: 1710 Two Story SFR - 1997 UBC	Option	2003
New	Approved Basic #02-100274 BP	Plan: 1710 Two Story SFR - 1997 UBC	Option	2003
New	Approved Basic #02-100831 BP	Plan: 1755 Split Level SFR - 1997 UBC		2003
New	Approved Basic #02-100831 BP	Plan: 1755 Split Level SFR - 1997 UBC		2003
New	Approved Basic #03-101064 BP	Plan: 1733 Two Story SFR - 1997 UBC		2003
New	Two-story SFR w/attached garage			2003
New	Approved Basic #02-100832 BP	Plan: 1455 Split Level SFR - 1997 UBC		2003
New	Approved Basic #02-109388 BP	Plan: 1575 Tri-Level SFR - 1997 UBC	Opt	2003
New	Approved Basic #02-100832 BP	Plan: 1455 Split Level SFR - 1997 UBC		2003
New	Approved Basic #02-100273 BP	Plan: 2117 Split Level SFR - 1997 UBC	Opti	2003
New	Approved Basic #01-105212 BP	Plan: 1538 Two Story SFR - 1997 UBC		2003
New	Two-story SFR - 1997 UBC			2003
New	Approved Basic #01-106982 BP	Plan: 1705 crawl (revised) SFR w/finished lo		2003
New	Rambler Style SFR - 1997 UBC	Plan: 1492		2003
New	Approved Basic #02-109811 BP	Plan: 1576 Rambler Style SFR - 1997 UBC		2003
New	Approved Basic #02-109809 BP	Plan: Jessica II Rambler Style SFR - 1997 UBC		2003
New	Approved Basic #01-105212 BP	Plan: 1538 Two Story SFR - 1997 UBC		2003
New	Approved Basic #01-106982 BP	Plan: 1705 crawl (revised) SFR w/finished lo		2003
New	Approved Basic #01-111402 BP	Plan: 1680-revised engineering Two-Story style SFR..		2003
New	Approved Basic #01-105212 BP	Plan: 1538 Two Story SFR - 1997 UBC		2003
New	Approved Basic #01-106982 BP	Plan: 1705 crawl (revised) SFR w/finished lo		2003
New	Approved Basic #01-105212 BP	Plan: 1538 Two Story SFR - 1997 UBC		2003
New	Approved Basic #01-105212 BP	Plan: 1538 Two Story SFR - 1997 UBC		2003
New	Approved Basic #01-106982 BP	Plan: 1705 crawl (revised) SFR w/finished lo		2003
New	Approved Basic #01-105212 BP	Plan: 1538 Two Story SFR - 1997 UBC		2003
New	Approved Basic #01-111402 BP	Plan: 1680-revised engineering Two-Story style SFR..		2003

Accessory Dwelling Units

Index # - File Name: 1.0022 - Single Family Dwellings Data\_Snohomish County.pdf

New	Approved Basic #01-105212 BP	Plan: 1538	Two Story SFR - 1997 UBC	2003
New	Approved Basic #02-100274 BP	Plan: 1710	Two Story SFR - 1997 UBC Option	2003
New	2 story SFR			2003
New	Approved Basic #00-104229 BP	Plan: 1533 revised	Two Story SFR - 1997 UE	2003
New	Approved Basic #02-102104-BP	Plan: 1420 - Rambler	Rambler Style SFR - 1997 UBC	2003
New	Approved Basic #00-105331 BP	Bldrs Plan No. 1932	Two Story SFR - 1997 UBC	2003
New	Approved Basic #02 110623-BP	Plan: 1621-3C	Two Story SFR - 2001 UBC	2003
New	Approved Basic #00-105331 BP	Bldrs Plan No. 1932	Two Story SFR - 1997 UBC	2003
New	Approved Basic #02 110623-BP	Plan: 1621-3C	Two Story SFR - 2001 UBC	2003
New	Approved Basic #00-105331 BP	Bldrs Plan No. 1932	Two Story SFR - 1997 UBC	2003
New	Approved Basic #02-110623-BP	Plan: 1621-3C	Two Story SFR - 2001 UBC	2003
New	Approved Basic #00-105331 BP	Bldrs Plan No. 1932	Two Story SFR - 1997 UBC	2003
New	Approved Basic #02 110623-BP	Plan: 1621-3C	Two Story SFR - 2001 UBC	2003
New	Approved Basic #02 110623-BP	Plan: 1621-3C	Two Story SFR - 2001 UBC	2003
New	Approved Basic #00-104229 BP	Plan: 1533 revised	Two Story SFR - 1997 UE	2003
New	Approved Basic #00-105331 BP	Bldrs Plan No. 1932	Two Story SFR - 1997 UBC	2003
New	Approved Basic #02 110623-BP	Plan: 1621-3C	Two Story SFR - 2001 UBC	2003
New	Approved Basic #00-105331 BP	Bldrs Plan No. 1932	Two Story SFR - 1997 UBC	2003
New	Approved Basic #00-104229 BP	Plan: 1533 revised	Two Story SFR - 1997 O	2003
New	Approved Basic #02-110623-BP	Plan: 1621-3C	Two Story SFR - 2001 UBC	2003
New	Approved Basic #00-104229 BP	Plan: 1533 revised	Two Story SFR - 1997 UE	2003
New	Approved Basic #00-105331 BP	Bldrs Plan No. 1932	Two Story SFR - 1997 UBC	2003
New	Approved Basic #02 110623-BP	Plan: 1621-3C	Two Story SFR - 2001 UBC	2003
New	Approved Basic #00-104229 BP	Plan: 1533 revised	Two Story SFR - 1997 UE	2003
New	Tri-Level SFR -1997 UBC	Plan: 1443		2003
New	Rambler Style SFR - 1997 UBC	Plan: 1420 (C)		2003
New	SFR w/finished basement - 1997 UBC	Plan: 2066		2003
New	SFR w/finished basement - 1997 UBC	Plan: 2058		2003
New	SFR w/finished basement - 1997 UBC	Plan: 2058		2003
New	SFR w/finished basement - 1997 UBC	Plan: 2058		2003
New	SFR w/finished basement - 1997 UBC	Plan: 2058		2003
New	SFR w/finished basement - 1997 UBC	Plan: 2058		2003
New	SFR w/finished basement - 1997 UBC	Plan: 2058		2003
New	SFR w/finished basement - 1997 UBC	Plan: 2066		2003
New	SFR w/finished basement - 1997 UBC	Plan: 2066		2003
New	Rambler Style SFR - 1997 UBC	Plan: 1357 - end		2003
New	Rambler Style SFR - 1997 UBC	Plan: 1357 - end		2003
New	Rambler Style SFR - 1997 UBC	Plan: 1357 - front		2003
New	Rambler Style SFR - 1997 UBC	Plan: 1604 - end		2003
New	Rambler Style SFR - 1997 UBC	Plan: 1357 - end		2003
New	Approved Basic #02-110621 BP	Plan: 1512	Rambler Style SFR - 1997 UBC	2003
New	Rambler Style SFR - 1997 UBC	Plan: 1357 - front		2003
New	Rambler Style SFR - 1997 UBC	Plan: 1357 - end		2003
New	Rambler Style SFR - 1997 UBC	Plan: 1604 - end		2003
New	Approved Basic #02-110737 BP	Plan: 1512 S	Rambler Style SFR - 1997 UBC	2003
New	Approved Basic 02-110737 BP	Plan: 1512 S	Rambler Style SFR - 1997 UBC	2003

Accessory Dwelling Units

Index # - File Name: 1.0022 - Single Family Dwellings Data\_Snohomish County.pdf

New	Approved Basic #00-100660 BP	Plan: 1803	Rambler Style SFR - 1997 UBC	2003
New	Approved Basic #02-110621 BP	Plan: 1512	Rambler Style SFR - 1997 UBC	2003
New	Approved Basic #00-100660 BP	Plan: 1803	Rambler Style SFR - 1997 UBC	2003
New	Approved Basic #03-100483 BP	Plan: 1604	Rambler Style SFR - 1997 UBC	2003
New	Approved Basic #00-100660 BP	Plan: 1803	Rambler Style SFR - 1997 UBC	2003
New	Approved Basic #02-110621 BP	Plan: 1512	Rambler Style SFR - 1997 UBC	2003
New	Approved Basic #00-100660 BP	Plan: 1803	Rambler Style SFR - 1997 UBC	2003
New	Rambler Style SFR - 1997 UBC	Plan: 1357 - front		2003
New	Approved Basic #02-110621 BP	Plan: 1512	Rambler Style SFR - 1997 UBC	2003
New	27x56 2002 Oakwood Homes Grand			2003
New	Split Entry Style SFR w/finished basement & basement garage.			2003
New	Split Entry style SFR w/finished basement & basement garage.			2003
New	Approved Basic #02-109376 BP	Plan: 2127	Two Story SFR - 1997 UBC	2003
New	Approved Basic #02-109374 BP	Plan: 2407	SFR w/finished lower floor - 1997 U	2003
New	Approved Basic #02-109375 BP	Plan: 2294	Two Story SFR - 1997 UBC	2003
New	Approved Basic #02-109374 BP	Plan: 2407	SFR w/finished lower floor - 1997 U	2003
New	Approved Basic #02-109376 BP	Plan: 2127	Two Story SFR - 1997 UBC	2003
New	Approved Basic 03-102527 BP	Plan: M2043A2F-1BD	Two Story SFR w/finished base	2003
New	Two Story SFR with 827 Sq Ft Finished Basement and Attached Garage			2003
New	Approved Basic 03-102527 BP	Plan: M2043A2F-1BD	Two Story SFR w/finished basem	2003
New	Two Story w/finished basement - 1997 UBC	Plan: 2043		2003
New	Rambler style SFR w/attached garage.			2003
New	Two Story SFR - 1997 UBC			2003
New	Two Story SFR - 1997 UBC			2003
New	Two Story SFR - 1997 UBC			2003
New	Two Story SFR - 1997 UBC			2003
New	Approved Basic #03-100663 BP	Plan: Sienna	Two Story SFR - 1997 UBC	2003
New	Approved Basic #03-101140 BP	Plan: Sahalee	Two Story SFR - 1997 UBC	2003
New	Approved Basic #03-101144 BP	Plan: Legacy	Two Story SFR - 1997 UBC	2003
New	Two Story SFR - 1997 UBC			2003
New	Approved Basic #03-101140 BP	Plan: Sahalee	Two Story SFR - 1997 UBC	2003
New	Approved Basic #03-100222 BP	Plan: A-5 1747	Two Story SFR - 1997 UBC	2003
New	Approved Basic #03-100226 BP	Plan: A-2 1785	Two Story SFR - 1997 UBC	2003
New	Approved Basic #03-1002230 BP	Plan: A-6 1556	SFR w/finished basement - 19	2003
New	Approved Basic #02-108413BP	Plan: 2006	Two-story SFR - 1997 UBC	2003
New	Approved Basic #03-100222 BP	Plan: A-5 1747	Two Story SFR - 1997 UBC	2003
New	Approved Basic #03-1002230 BP	Plan: A-6 1556	SFR w/finished basement - 19	2003
New	Approved Basic #03-100228 BP	Plan: A-1 1666	Two Story SFR - 1997 UBC	2003
New	Approved Basic #03-100226 BP	Plan: A-2 1785	Two Story SFR - 1997 UBC	2003
New	Approved Basic #03-100228 BP	Plan: A-1 1666	Two Story SFR - 1997 UBC	2003
New	Approved Basic #03-100222 BP	Plan: A-5 1747	Two Story SFR - 1997 UBC	2003
New	Approved Basic #02-108413BP	Plan: 2006	Two-story SFR - 1997 UBC	2003
New	Approved Basic #03-102180 BP	Plan: A-7 1899	Two Story SFR - 1997 UBC	2003
New	Two Story SFR - 1997 UBC	Plan: A-9 (2141)		2003
New	Approved Basic #03-100222 BP	Plan: A-5 1747	Two Story SFR - 1997 UBC	2003
New	Approved Basic #02-108413BP	Plan: 2006	Two-story SFR - 1997 UBC	2003
New	Approved Basic #03-105893 BP	Plan: A-9 (2141)	Two Story SFR - 1997 UBC	2003



Accessory Dwelling Units

Index # - File Name: 1.0022 - Single Family Dwellings Data\_Snohomish County.pdf

New	Approved Basic #03-100230 BP	Plan: A-6 1556 SFR w/finished basement - 1997 UBC	2003
New	Approved Basic #03-100222 BP	Plan: A-5 1747 Two Story SFR - 1997 UBC	2003
New	Approved Basic #03-100222 BP	Plan: A-5 1747 Two Story SFR - 1997 UBC	2003
New	Approved Basic #03-100230 BP	Plan: A-6 1556 SFR w/finished basement - 199	2003
New	Approved Basic #03-100222 BP	Plan: A-5 1747 Two Story SFR - 1997 UBC	2003
New	Approved Basic #03-100222 BP	Plan: A-5 1747 Two Story SFR - 1997 UBC	2003
New	Approved Basic #03-105893 BP	Plan: A-9 (2141) Two Story SFR - 1997 UBC	2003
New	Approved Basic #03-100222 BP	Plan: A-5 1747 Two Story SFR - 1997 UBC	2003
New	Approved Basic #03-1002230 BP	Plan: A-6 1556 SFR w/finished basement - 19	2003
New	Approved Basic #03-100222 BP	Plan: A-5 1747 Two Story SFR - 1997 UBC	2003
New	Approved Basic #03-100222 BP	Plan: A-5 (1747) Two Story SFR - 1997 UBC	2003
New	Approved Basic #02-108413 BP	Plan: 2006 Two Story SFR -1997 UBC	Opti 2003
New	Approved Basic #02-108413 BP	Plan: 2006 Two Story SFR - 1997 UBC	Optioi 2003
New	Approved Basic #03-100222 BP	Plan: A-5 1747 Two Story SFR - 1997 UBC	2003
New	Approved Basic #03-100222 BP	Plan: A-5 1747 Two Story SFR - 1997 UBC	2003
New	Approved Basic #02-108413BP	Plan: 2006 Two-story SFR - 1997 UBC	2003
New	Approved Basic #03-105893 BP	Plan: A-9 (2141) Two Story SFR - 1997 UBC	2003
New	Two Story SFR - 1997 UBC	Plan: A 2	2003
New	Two Story SFR - 1997 UBC	Plan: A 1	2003
New	Split Entry SFR - 1997 UBC	Plan: A 4	2003
New	Approved Basic #03-100224 BP	Plan: A-4 1893 SFR w/finished basement - 199	2003
New	Approved Basic #03-100224 BP	Plan: A-4 1893 SFR w/finished basement - 199	2003
New	Approved Basic #03-100222 BP	Plan: A-5 1747 Two Story SFR - 1997 UBC	2003
New	Approved Basic #03-105893 BP	Plan: A-9 (2141) Two Story SFR - 1997 UBC	2003
New	Approved Basic #02-108413BP	Plan: 2006 Two-story SFR - 1997 UBC	2003
New	Approved Basic #03-100224 BP	Plan: A-4 1893 SFR w/finished basement - 1997	2003
New	Approved Basic #03-100222 BP	Plan: A-5 1747 Two Story SFR - 1997 UBC	2003
New	Approved Basic #03-100225 BP	Plan: A-3 - 1700 Two Story SFR - 1997 UBC	2003
New	Approved Basic #03-100225 BP	Plan: A-3 - 1700 Two Story SFR - 1997 UBC	2003
New	Two Story SFR - 1997 UBC	Plan: A 3	2003
New	Two Story SFR - 1997 UBC	Plan: A 5	2003
New	Approved Basic #03-100225 BP	Plan: A-3 - 1700 Two Story SFR - 1997 UBC	2003
New	Approved Basic #03-100222 BP	Plan: A-5 1747 Two Story SFR - 1997 UBC	2003
New	Approved Basic #03-100224 BP	Plan: A-4 1893 SFR w/finished basement - 199	2003
New	Approved Basic #02-105673 BP	Plan: 1799 Two Story SFR - 1997	2003
New	Approved Basic #02-105667 BP	Plan: 1818 Two Story SFR - 1997 UBC	2003
New	Approved Basic #02-105667 BP	Plan: 1818 Two Story SFR - 1997 UBC	2003
New	Approved Basic #02-105673 BP	Plan: 1799 Two Story SFR - 1997	2003
New	Approved Basic #02-105665 BP	Plan: 1573 Two Story SFR - 1997 UBC	2003
New	Approved Basic #02-105668 BP	Plan: 1885 Two Story SFR - 1997 UBC	2003
New	Approved Basic #02-105673 BP	Plan: 1799 Two Story SFR - 1997	2003
New	Approved Basic #02-105666 BP	Plan: 1799 Two Story SFR - 1997 UBC	2003
New	Approved Basic #02-105665 BP	Plan: 1573 Two Story SFR - 1997 UBC	2003
New	Approved Basic #02-105673 BP	Plan: 1799 Two Story SFR - 1997	2003
New	Approved Basic #02-105673 BP	Plan: 1799 Two Story SFR - 1997	2003
New	Approved Basic #02-105668 BP	Plan: 1885 Two Story SFR - 1997 UBC	2003
New	Approved Basic #02-105665 BP	Plan: 1573 Two Story SFR - 1997 UBC	2003

Accessory Dwelling Units

Index # - File Name: 1.0022 - Single Family Dwellings Data\_Snohomish County.pdf

New	Approved Basic #02-105673 BP	Plan: 1799 Two Story SFR - 1997	2003
New	Approved Basic #02-105665 BP	Plan: 1573 Two Story SFR - 1997 UBC	2003
New	Approved Basic #02-105667 BP	Plan: 1818 Two Story SFR - 1997 UBC	2003
New	Approved Basic #02-105667 BP	Plan: 1818 Two Story SFR - 1997 UBC	2003
New	Approved Basic #02-105668 BP	Plan: 1885 Two Story SFR - 1997 UBC	2003
New	Approved Basic #02-105673 BP	Plan: 1799 Two Story SFR - 1997	2003
New	Approved Basic #03-100552 BP	Plan: 1885-2 Two Story SFR - 1997 UBC	Opt 2003
New	Approved Basic #02-105667 BP	Plan: 1818 Two Story SFR - 1997 UBC	2003
New	Approved Basic #02-105667 BP	Plan: 1818 Two Story SFR - 1997 UBC	2003
New	Approved Basic #02-105667 BP	Plan: 1818 Two Story SFR - 1997 UBC	2003
New	Approved Basic #03-100552 BP	Plan: 1885-2 Two Story SFR - 1997 UBC	Opt 2003
New	Approved Basic #02-105665 BP	Plan: 1573 Two Story SFR - 1997 UBC	2003
New	Approved Basic #03-100552 BP	Plan: 1885-2 Two Story SFR - 1997 UBC	Opti 2003
New	Approved Basic #02-105666 BP	Plan: 1799 Two Story SFR - 1997 UBC	2003
New	Approved Basic #03-110428-BP	Plan: Madison Rambler style SFR - 1997 UBC	2003
New	Two Story Duplex - 1997 UBC		2003
New	Rambler Style SFR - 1997 UBC	Plan: 1833	2003
New	Rambler Style SFR - 1997 UBC	Plan: 1833	2003
New	Approved Basic #02-109809 BP	Plan: Jessica II Rambler Style SFR - 1997 UBC	2003
New	Approved Basic #03-110428-BP	Plan: Madison Rambler style SFR - 1997 UBC	2003
New	Approved Basic #02-109811 BP	Plan: 1576 Rambler Style SFR - 1997 UBC	2003
New	Approved Basic #02-109809 BP	Plan: Jessica II Rambler Style SFR - 1997 UBC	2003
New	Approved Basic #02-109811 BP	Plan: 1576 Rambler Style SFR - 1997 UBC	2003
New	Approved Basic #02-109809 BP	Plan: Jessica II Rambler Style SFR - 1997 UBC	2003
New	Approved Basic #02-109811 BP	Plan: 1576 Rambler Style SFR - 1997 UBC	2003
New	Approved Basic #02-109361 BP	Plan 2553 B Two Story SFR - 1997 UBC	2003
New	28x56 Marlette/Sierra Vista 2003		2003
New	Two-story SFR - 1997 UBC		2003
New	Approved Basic #02-110641BP	Plan: 2300 Two-story SFR - 1997 UBC	2003
New	Approved Basic #02-110376 BP	Plan: Auburn (revised) Rambler Style SFR - 1997 UBC	2003
New	Approved Basic #01-113747 BP	Plan: 2024 Two Story SFR - 1997 UBC	2003
New	Rambler w/ 2 Car		2003
New	Rambler Style SFR - 1997 UBC	Plan: 1833	2003
New	Rambler Style SFR - 1997 UBC	Plan: 1833	2003
New	Approved Basic #02-106983 BP	Plan: 01108 Rambler Style SFR - 1997 UBC	C 2003
New	Approved Basic # 03-101040 BP	Plan: Katie Two Story SFR - 1997 UBC	2003
New	Rambler Style SFR - 1997 UBC		2003
New	Approved Basic # 03-101040 BP	Plan: Katie Two Story SFR - 1997 UBC	2003
New	Approved Basic #02-109359 BP	Plan: 2443 B Two Story SFR - 1997 UBC	2003
New	Approved Basic #02-110641BP	Plan: 2300 Two-story SFR - 1997 UBC	2003
New	2 story SFR with attached garage		2003
New	2-story SFR w/garage		2003
New	Approved Basic #02-109967 BP	Plan 2121 SFR w/finished lower floor - 1997 UBC	2003
New	Approved Basic #02-107152 BP	Plan: 2741 A Two Story SFR - 1997 UBC	2003
New	Approved Basic #03-100209 BP	Plan: 2452 - Westcott - A Two Story SFR - 1997 UBC	2003
New	Approved Basic #03-100209 BP	Plan: 2452 - Westcott - A Two Story SFR - 1997 UBC	2003
New	SFR with 470 Sq Ft Finished Basement and Attached Garage- 1997 UBC		2003

Accessory Dwelling Units

Index # - File Name: 1.0022 - Single Family Dwellings Data\_Snohomish County.pdf

New	Two-story SFR w/attached garage		2003
New	Approved Basic #02-100245 BP	Plan: 1644 Two Story SFR - 1997 UBC	2003
New	Approved Basic #02-108290 BP	Plan: 1525 C SFR w/finished basement - 1997 UBC	2003
New	Approved Basic #01-104718 BP	Plan: 1760 S/H Split Level SFR - 1997 UBC	2003
New	Approved Basic #02-108290 BP	Plan: 1525 C SFR w/finished basement - 1997 UBC	2003
New	Two Story SFR with Attached Garage - 1997 UBC		2003
New	Approved Basic #02-110652 BP	Plan: 1301 Rambler Style SFR - 1997 UBC	2003
New	Approved Basic #02-110652 BP	Plan: 1301 Rambler Style SFR - 1997 UBC	2003
New	Approved Basic #03-105919 BP	Plan: 1301 Rambler Style SFR - 1997 UBC	2003
New	2 Story w/ 3 Car		2003
New	2 Story SFR w/ 2 Car		2003
New	2 Story SFR w/ 2 Car		2003
New	2 Story SFR w/ 3 Car		2003
New	Approved Basic #03-103357 BP	Plan: 2370 A Two Story SFR - 1997 UBC	2003
New	Approved Basic #03- 103362 BP	Plan: 2224 B Two Story SFR - 1997 UBC	2003
New	Approved Basic #03- 103359 BP	Plan: 2370 B Two Story SFR - 1997 UBC	2003
New	Two Story SFR - 1997 UBC		2003
New	Approved Basic #02-110641BP	Plan: 2300 Two-story SFR - 1997 UBC	2003
New	Approved Basic #02-109359 BP	Plan: 2443 B Two Story SFR - 1997 UBC	2003
New	Approved Basic #02-109967 BP	Plan 2121 SFR w/finished lower floor - 1997 UBC	2003
New	Approved Basic #02-109967 BP	Plan 2121 SFR w/finished lower floor - 1997 UBC	2003
New	Approved Basic #01-101344 BP	Plan: 1460 S SFR w/finished lower floor - 1997 UBC	2003
New	Approved Basic #02-107156 BP	Plan: 2155-A Two Story SFR - 1997 UBC	2003
New	Approved Basic #02-107152 BP	Plan: 2741 A Two Story SFR - 1997 UBC	2003
New	Approved Basic #02-107151 BP	Plan: 2565-B Two Story SFR - 1997 UBC	2003
New	Approved Basic #02-107155 BP	Plan: 2565-A Two Story SFR - 1997 UBC	2003
New	Approved Basic #02-109967 BP	Plan 2121 SFR w/finished lower floor - 1997 UBC	2003
New	Approved Basic #03-100209 BP	Plan: 2452 - Westcott - A Two Story SFR - 1997 UBC	2003
New	Approved Basic #02-108413BP	Plan: 2006 Two-story SFR - 1997 UBC	2003
New	Approved Basic #02-108413BP	Plan: 2006 Two-story SFR - 1997 UBC	2003
New	Approved Basic #02-107151 BP	Plan: 2565-B Two Story SFR - 1997 UBC	2003
New	Approved Basic #02-107158 BP	Plan: 2373 A Two Story SFR - 1997 UBC	2003
New	Approved Basic #02-107154 BP	Plan: 2741 C Two Story SFR - 1997 UBC	2003
New	Approved Basic #02-107155 BP	Plan: 2565-A Two Story SFR - 1997 UBC	2003
New	Approved Basic #02-107152 BP	Plan: 2741 A Two Story SFR - 1997 UBC	2003
New	Approved Basic #02-107151 BP	Plan: 2565-B Two Story SFR - 1997 UBC	2003
New	Approved Basic #03-100209 BP	Plan: 2452 - Westcott - A Two Story SFR - 1997 UBC	2003
New	Approved Basic #02-107158 BP	Plan: 2373 A Two Story SFR - 1997 UBC	2003
New	Approved Basic #02-107155 BP	Plan: 2565-A Two Story SFR - 1997 UBC	2003
New	Approved Basic #02-107156 BP	Plan: 2155-A Two Story SFR - 1997 UBC	2003
New	Approved Basic #03-100209 BP	Plan: 2452 - Westcott - A Two Story SFR - 1997 UBC	2003
New	Approved Basic #03-100209 BP	Plan: 2452 - Westcott - A Two Story SFR - 1997 UBC	2003
New	Approved Basic #02-107156 BP	Plan: 2155-A Two Story SFR - 1997 UBC	2003
New	Rambler Style SFR w/finished basement - 1997 UBC		2003
New	Rambler w/ garage		2003
New	Rambler w/ garage		2003
New	28x60, 2002 Karsten		2003

Accessory Dwelling Units

Index # - File Name: 1.0022 - Single Family Dwellings Data\_Snohomish County.pdf

New	2 story sfr/w attached garage		2003
New	2 Story SFR w/ 2 Car		2003
New	SFR Rambler w/ Daylight basement & 2 Car Garage		2003
New	Approved Basic #03-100503 BP	Plan 2504 Two-story SFR - 1997 UBC	2003
New	SFR with finished basement - 1997 UBC		2003
New	Two Story SFR with 575 Sq Ft Finished Basement and Attached Garage		2003
New	Approved Basic #02- 108794 BP	Plan #668 Split Level SFR - 1997 UBC	2003
New	2 Story w/ Finished Basement & 2 Car Garage		2003
New	Approved Basic #03-105005 BP	Plan: 2651-A Two Story w/finished basement - 1997 UBC	2003
New	SFR with finished basement - 1997UBC		2003
New	Approved Basic #03-100849 BP	Plan: 2486 Two Story SFR - 1997 UBC	2003
New	Approved Basic #02-109726 BP	Plan: 2493 Two Story SFR - 1997 UBC	2003
New	Approved Basic #02-110396 BP	Plan: 2387 Two Story SFR - 1997 UBC	2003
New	Two Story SFR - 1997 UBC	Plan: 2171	2003
New	One story SFR w/semi-finished basement & attached garage		2003
New	Approved Basic #02-105573 BP	Plan: 1799 Two Story SFR - 1997 UBC	2003
New	Approved Basic #02-105572 BP	Plan: 1682 -B (side entry) Two Story SFR - 1997 UB	2003
New	Two Story SFR - 1997 UBC	Plan: 2387	2003
New	2-story w/garage		2003
New	Approved Basic #02-105576 BP	Plan: 1885 Two Story SFR - 1997 UBC	2003
New	Approved Basic #02-105576 BP	Plan: 1885 Two Story SFR - 1997 UBC	2003
New	Approved Basic #02-105568 BP	Plan: 1573-2 Two Story SFR - 1997 UBC	2003
New	Approved Basic #02-105568 BP	Plan: 1573-2 Two Story SFR - 1997 UBC	2003
New	Approved Basic #02-105573 BP	Plan: 1799 Two Story SFR - 1997 UBC	2003
New	Approved Basic #02-105574 BP	Plan: 1818 Two Story SFR - 1997 UBC	2003
New	Approved Basic #02-105568 BP	Plan: 1573-2 Two Story SFR - 1997 UBC	2003
New	Approved Basic #02-105572 BP	Plan: 1682 -B (side entry) Two Story SFR - 1997 UB	2003
New	Approved Basic #02-105576 BP	Plan: 1885 Two Story SFR - 1997 UBC	2003
New	Approved Basic #02-105576 BP	Plan: 1885 Two Story SFR - 1997 UBC	2003
New	Approved Basic #02-108690-BP	Plan: 1677 Rambler Style SFR - 1997 UBC	2003
New	Approved Basic #02-108690-BP	Plan: 1677 Rambler Style SFR - 1997 UBC	2003
New	Approved Basic #02-108265 BP	Plan: 2116 Two Story SFR - 1997 UBC	2003
New	Approved Basic #02-109483 BP	Plan: 1839 Two Story SFR - 1997 UBC	2003
New	Approved Basic #02-108689-BP	Plan: 2002 Rambler Style SFR - 1997 UBC	2003
New	Approved Basic #02-109483 BP	Plan: 1839 Two Story SFR - 1997 UBC	2003
New	Approved Basic #01-107401BP	Plan: 1520 Rambler Style SFR - 1997 UBC	2003
New	Approved Basic #03-100446 BP	Plan: 2838 Two Story SFR - 1997 UBC	2003
New	Approved Basic #01-107401BP	Plan: 1520 Rambler Style SFR - 1997 UBC	2003
New	Approved Basic #01-107401BP	Plan: 1520 Rambler Style SFR - 1997 UBC	2003
New	Approved Basic 02-110377 BP	Plan 2006 Two Story SFR - 1997 UBC	2003
New	Approved Basic #02-103157 BP	Plan No. 2108 SSI Two Story SFR - 1997 UBC	2003
New	Approved Basic #02-110008 BP	Plan 2024 Two-story SFR - 1997 UBC	2003
New	Approved Basic #02-110008 BP	Plan 2024 Two-story SFR - 1997 UBC	2003
New	Approved Basic 02-110377 BP	Plan 2006 Two Story SFR - 1997 UBC	2003
New	Approved Basic #02-103157 BP	Plan No. 2108 SSI Two Story SFR - 1997 UBC	2003
New	Approved Basic #02-110377 BP	Plan 2006 Two Story SFR - 1997 UBC	2003
New	Approved Basic #02-103159 BP	Plan: 2180 SSI Two Story SFR....1997 UBC	2003

Accessory Dwelling Units

Index # - File Name: 1.0022 - Single Family Dwellings Data\_Snohomish County.pdf

New	Approved	Basic 02-110377 BP	Plan 2006	Two Story SFR - 1997 UBC	2003
New	Approved	Basic #02-103157 BP	Plan No. 2108 SSI	Two Story SFR - 1997 UBC	2003
New	Approved	Basic #02-110377 BP	Plan 2006	Two Story SFR - 1997 UBC	2003
New	Approved	Basic #02-103157 BP	Plan No. 2108 SSI	Two Story SFR - 1997 UBC	2003
New	Approved	Basic 02-110377 BP	Plan 2006	Two Story SFR - 1997 UBC	2003
New	Approved	Basic #02-103157 BP	Plan No. 2108 SSI	Two Story SFR - 1997 UBC	2003
New	Approved	Basic 02-110377 BP	Plan 2006	Two Story SFR - 1997 UBC	2003
New	Approved	Basic 02-110377 BP	Plan 2006	Two Story SFR - 1997 UBC	2003
New	Approved	Basic #01-107405 BP	Plan: 1446	Rambler Style SFR - 1997 UBC	2003
New	Approved	Basic #02-103157 BP	Plan No. 2108 SSI	Two Story SFR - 1997 UBC	2003
New	Approved	Basic 02-110377 BP	Plan 2006	Two Story SFR - 1997 UBC	2003
New	Approved	Basic 02-110377 BP	Plan 2006	Two Story SFR - 1997 UBC	2003
New	Approved	Basic 02-110377 BP	Plan 2006	Two Story SFR - 1997 UBC	2003
New	Approved	Basic #02-110377 BP	Plan 2006	Two Story SFR - 1997 UBC	2003
New	Approved	Basic #02-103159 BP	Plan: 2180 SSI	Two Story SFR....1997 UBC	2003
New	Approved	Basic #02-110377 BP	Plan 2006	Two Story SFR - 1997 UBC	2003
New	Approved	Basic #02-103159 BP	Plan: 2180 SSI	Two Story SFR....1997 UBC	2003
New	Approved	Basic 02-110377 BP	Plan 2006	Two Story SFR - 1997 UBC	2003
New	Approved	Basic #02-103159 BP	Plan: 2180 SSI	Two Story SFR....1997 UBC	2003
New	Approved	Basic #02-110008 BP	Plan 2024	Two-story SFR - 1997 UBC	2003
New	Approved	Basic 02-110377 BP	Plan 2006	Two Story SFR - 1997 UBC	2003
New	Approved	Basic #01-107405 BP	Plan: 1446	Rambler Style SFR - 1997 UBC	2003
New	Approved	Basic 02-110377 BP	Plan 2006	Two Story SFR - 1997 UBC	2003
New	Approved	Basic #02-107552 BP	Plan: 2444 A	Two Story SFR - 1997 UBC	2003
New	Approved	Basic #02-107552 BP	Plan: 2444 A	Two Story SFR - 1997 UBC	2003
New	Approved	Basic #02-108385 BP	Plan: 2042 C	Two Story SFR - 1997 UBC	2003
New	Approved	Basic #02-109233 BP	Plan: 2444 B	Two Story SFR - 1997 UBC	2003
New	Approved	Basic #02-108385 BP	Plan: 2042 C	Two Story SFR - 1997 UBC	2003
New	Approved	Basic #01-111603 BP	Bldrs Plan 2968	Two-story style SFR.....1997 UBC	2003
New	Approved	Basic #03-107936 BP	Plan: 3175	Two-story SFR - 1997 UBC	2003
New	Approved	Basic #01-111603 BP	Bldrs Plan 2968	Two-story style SFR.....1997 UBC	2003
New		1997 Fleetwood 27 x 52			2003
New	Approved	Basic #00-110376 BP	Plan 1833 w/bonus & nook	Two Story SFR - 1997 UB	2003
New	Approved	Basic #01-111603 BP	Bldrs Plan 2968	Two-story style SFR.....1997 UBC	2003
New	Approved	Basic #00-109218 BP	Plan: 453	Two Story SFR - 1997 UBC	2003
New	Approved	Basic #03-100629 BP	Plan: 458	Two Story SFR - 1997 UBC	2003
New	Approved	Basic #03-100630 BP	Plan: 457	Two Story SFR - 1997 UBC	2003
New	Approved	Basic #00-109216 BP	Plan: 455	Two Story SFR - 1997 UBC	2003
New	Approved	Basic #00-109215 BP	Plan: 456	Two Story SFR - 1997 UBC	2003
New		Two Story SFR - 1997 UBC	Plan: 458		2003
New	Approved	Basic #00-109216 BP	Plan: 455	Two Story SFR - 1997 UBC	2003
New	Approved	Basic #00-109215 BP	Plan: 456	Two Story SFR - 1997 UBC	2003
New		Two Story SFR - 1997 UBC	Plan: 457		2003
New	Approved	Basic #00-109217 BP	Plan: 451	Two Story SFR - 1997 UBC	2003
New	Approved	Basic #03-100630 BP	Plan: 457	Two Story SFR - 1997 UBC	2003

Accessory Dwelling Units

Index # - File Name: 1.0022 - Single Family Dwellings Data\_Snohomish County.pdf

New	Approved Basic #00-109218 BP	Plan: 453	Two Story SFR - 1997 UBC	2003
New	Approved Basic #00-109217 BP	Plan: 451	Two Story SFR - 1997 UBC	2003
New	Approved Basic #00-109218 BP	Plan: 453	Two Story SFR - 1997 UBC	2003
New	Approved Basic #03-100629 BP	Plan: 458	Two Story SFR - 1997 UBC	2003
New	Approved Basic #00-109215 BP	Plan: 456	Two Story SFR - 1997 UBC	2003
New	Approved Basic #00-109214 BP	Plan: 454	Two Story SFR - 1997 UBC	2003
New	Approved Basic #00-109216 BP	Plan: 455	Two Story SFR - 1997 UBC	2003
New	2592sf one-story SFR - 1997 UBC			2003
New	SFR with unfinished daylight basement - 1997 UBC			2003
New	Approved Basic #00-109214 BP	Plan: 454	Two Story SFR - 1997 UBC	2003
New	Approved Basic #00-109216 BP	Plan: 455	Two Story SFR - 1997 UBC	2003
New	Approved Basic #00-109214 BP	Plan: 454	Two Story SFR - 1997 UBC	2003
New	Approved Basic #00-109215 BP	Plan: 456	Two Story SFR - 1997 UBC	2003
New	Approved Basic #00-109214 BP	Plan: 454	Two Story SFR - 1997 UBC	2003
New	Approved Basic #00-109215 BP	Plan: 456	Two Story SFR - 1997 UBC	2003
New	Approved Basic #00-109218 BP	Plan: 453	Two Story SFR - 1997 UBC	2003
New	Approved Basic #00-109216 BP	Plan: 455	Two Story SFR - 1997 UBC	2003
New	Approved Basic #00-109214 BP	Plan: 454	Two Story SFR - 1997 UBC	2003
New	Approved Basic #00-109215 BP	Plan: 456	Two Story SFR - 1997 UBC	2003
New	Approved Basic #00-109218 BP	Plan: 453	Two Story SFR - 1997 UBC	2003
New	Approved Basic #03-100629 BP	Plan: 458	Two Story SFR - 1997 UBC	2003
New	Approved Basic #00-109215 BP	Plan: 456	Two Story SFR - 1997 UBC	2003
New	Approved Basic #03-100630 BP	Plan: 457	Two Story SFR - 1997 UBC	2003
New	Approved Basic #00-109216 BP	Plan: 455	Two Story SFR - 1997 UBC	2003
New	Approved Basic #00-109215 BP	Plan: 456	Two Story SFR - 1997 UBC	2003
New	Approved Basic #00-109217 BP	Plan: 451	Two Story SFR - 1997 UBC	2003
New	Approved Basic #02-107293 BP	Plan: 668	Split Level - 1997 UBC	2003
New	Two-story SFR - 1997 UBC			2003
New	Approved Basic #03-102875 BP	Plan: 457-revised	Two Story SFR - 1997 UBC	2003
New	Two-story SFR with bonus room over garage - 1997 UBC			2003
New	26 -8 x 66 - 2002 - Marlette			2003
New	2 story SFR w/attached garage			2003
New	2-Story SFR w/attached garage and bonus room above garage w/attached 507 sq. ft. accessory ;			2003
New	SFR w/basement - 1997 UBC			2003
New	Two Story SFR - 1997 UBC			2003
New	Two Story SFR w/semi finished basement - 1997 UBC			2003
New	Rambler Style SFR - 1997 UBC			2003
New	Rambler Style SFR - 1997 UBC			2003
New	One-story SFR rambler-style 1997 UBC			2003
New	Two-story SFR mid-level entry 1997 UBC	Plan 1344		2003
New	Two-story SFR - 1997 UBC			2003
New	Rambler style SFR w/attached garage.			2003
New	Approved Basic #03-100749 BP	Plan: Jessica III	Rambler Style SFR - 1997 UBC	2003
New	Rambler Style SFR - 1997 UBC			2003
New	Approved Basic #02-109690 BP	Plan: Olympic/Gable (D)	Two Story SFR - 1997 UE	2003
New	Approved Basic #02-109694 BP	Plan: Stewart/Gable (D)	SFR w/finished lower floor	2003
New	Approved Basic #02-109693 BP	Plan: Whitney - Hip (D)	Two Story SFR - 1997 UBC	2003

Accessory Dwelling Units

Index # - File Name: 1.0022 - Single Family Dwellings Data\_Snohomish County.pdf

New	Two-story SFR - 1997 UBC		2003
New	Approved Basic #02-109684BP	Plan: Jasper/Gable (A) Two Story SFR - 1997 UBC	2003
New	Approved Basic #02-110070 BP	Plan: Trinity/Gable (D) Two Story SFR - 1997 UBC	2003
New	Approved Basic #02-109694 BP	Plan: Stewart/Gable (D) SFR w/finished lower floor	2003
New	Approved Basic #02-110069 BP	Plan: Adams/Gable (D) Two Story SFR - 1997 UBC	2003
New	Approved Basic #02-109690 BP	Plan: Olympic/Gable (D) Two Story SFR - 1997 UE	2003
New	Approved Basic #02-109693 BP	Plan: Whitney - Hip (D) Two Story SFR - 1997 UBC	2003
New	Approved Basic #02-110072 BP	Plan: Pilchuck Gable (B) Two Story SFR - 1997 UBC	2003
New	Approved Basic #02-109683 BP	Plan: Shasta/Gable (C) Two Story SFR - 1997 UBC	2003
New	Approved Basic #02-109684 BP	Plan: Jasper/Gable (A) Two Story SFR - 1997 UBC	2003
New	Approved Basic #02-110070 BP	Plan: Trinity/Gable (D) Two Story SFR - 1997 UBC	2003
New	Approved Basic #02-109690 BP	Plan: Olympic/Gable (D) Two Story SFR - 1997 UE	2003
New	Approved Basic #03-101083 BP	Plan: Siskiyou/Gable (B) Two Story SFR - 1997 UB	2003
New	Approved Basic #02-110070 BP	Plan: Trinity/Gable (D) Two Story SFR - 1997 UBC	2003
New	Approved Basic #02-109683 BP	Plan: Shasta/Gable (C) Two Story SFR - 1997 UBC	2003
New	Approved Basic #02-109684 BP	Plan: Jasper/Gable (A) Two Story SFR - 1997 UBC	2003
New	Approved Basic #02-109694 BP	Plan: Stewart/Gable (D) SFR w/finished lower floor	2003
New	Approved Basic #03-101083 BP	Plan: Siskiyou/Gable (B) Two Story SFR - 1997 UB	2003
New	Approved Basic #02-109683 BP	Plan: Shasta/Gable (C) Two Story SFR - 1997 UBC	2003
New	Approved Basic #02-109687 BP	Plan: Whitney/Gable (C) Two Story SFR - 1997 UBC	2003
New	Approved Basic #02-109683 BP	Plan: Shasta/Gable (C) Two Story SFR - 1997 UBC	2003
New	Approved Basic #02-109690 BP	Plan: Olympic/Gable (D) Two Story SFR - 1997 UBC	2003
New	Approved Basic #02-109684 BP	Plan: Jasper/Gable (A) Two Story SFR - 1997 UBC	2003
New	Approved Basic #02-109686 BP	Plan: Glacier/Gable (A) Two Story SFR - 1997 UBC	2003
New	Approved Basic #02-109694 BP	Plan: Stewart/Gable (D) SFR w/finished lower floor	2003
New	Approved Basic #02-110070 BP	Plan: Trinity/Gable (D) Two Story SFR - 1997 UBC	2003
New	Approved Basic #02-109683 BP	Plan: Shasta/Gable (C) Two Story SFR - 1997 UBC	2003
New	Approved Basic #02-109067 BP	Plan: Siskiyou/Gable - Side Two Story SFR - 1997 UB	2003
New	Approved Basic #02-109693 BP	Plan: Whitney - Hip (D) Two Story SFR - 1997 UBC	2003
New	Approved Basic #02-109683 BP	Plan: Shasta/Gable (C) Two Story SFR - 1997 UBC	2003
New	Approved Basic #02-106234 BP	Plan: Siskiyou/Gable Two Story SFR - 1997 UBC	2003
New	2-story SFR w/garage		2003
New	2 story SFR w/attached 3 car garage		2003
New	Two Story SFR - 1997 UBC		2003
New	Approved Basic #03-100353 BP	Plan: 1484 - revised Two Story SFR - 1997 UBC	2003
New	2-Story SFR w/attached garage.		2003
New	Approved Basic #02-108403 BP	Plan: 1220 SFR w/semi-finished basement - 1997 L	2003
New	Approved Basic #02-108403 BP	Plan: 1220 SFR w/semi-finished basement - 1997 L	2003
New	Approved Basic #02-108403 BP	Plan: 1220 SFR w/semi-finished basement - 1997 L	2003
New	RE-INSPECT FEE MUST BE PAID PRIOR TO ANOTHER INSPECTION. -per Mick 2/24/03	Approved	2003
New	Approved Basic #03-101337 BP	Plan: 1597 Two-story SFR - 1997 UBC	2003
New	Approved Basic #02-108403 BP	Plan: 1220 SFR w/semi-finished basement - 1997 L	2003
New	Approved Basic #02-108402 BP	Plan: 1478 SFR w/finished basement - 1997 UBC	2003
New	Approved Basic #03-100353BP	Plan 1484 - revised Two-story SFR - 1997UBC	2003
New	Approved Basic #02-108403 BP	Plan: 1220 SFR w/semi-finished basement - 1997 L	2003
New	Approved Basic #03-101337 BP	Plan: 1597 Two-story SFR - 1997 UBC	2003
New	Approved Basic #03-100765 BP	Plan: 1704 Split Entry SFR - 1997 UBC	2003

Accessory Dwelling Units

Index # - File Name: 1.0022 - Single Family Dwellings Data\_Snohomish County.pdf

New	Two-story SFR - 1997 UBC	Plan 1597	PER APPROVAL FROM FAITH LUMSDEN ON 2/	2003
New	Approved Basic #03-101337 BP	Plan: 1597	Two-story SFR - 1997 UBC	2003
New	Approved Basic #03-100353 BP	Plan: 1484 - revised	Two Story SFR - 1997 UBC	2003
New	2 story SFR w/attached garage 1997 UBC	Plan #3824	4 bedroom design	2003
New	Approved Basic #01-111603 BP	Bldrs Plan 2968	Two-story style SFR.....1997 UBC	2003
New	One-story SFR w/finished basement			2003
New	Approved Basic #03-101092 BP	Plan: 1827/2	Rambler style SFR - 1997 UBC	2003
New	Rambler Style SFR - 1997 UBC			2003
New	Approved Basic #03-109592 BP	Plan: 1733	Rambler Style SFR - 1997 UBC	2003
New	One-story SFR - 1997 UBC	Plan: EC1966		2003
New	Rambler Style SFR - 1997 UBC			2003
New	Approved Basic #03-101092 BP	Plan: 1827/2	Rambler style SFR - 1997 UBC	2003
New	Approved Basic #03-102734 BP	Plan: 2200	Rambler style SFR - 1997 UBC	2003
New	Rambler Style SFR - 1997 UBC			2003
New	Rambler w/ 3 Car			2003
New	Approved Basic #99-109495 BP	Plan: 2771	Two Story SFR - 1997 U	2003
New	2 story SFR w/attached garage 1997 UBC			2003
New	2-story w/ garage			2003
New	2 story SFR with covered porch			2003
New	Two Story SFR - 1997 UBC			2003
New	Approved Basic #03-104263 BP	Plan #EC1966	Rambler Style SFR - 1997 UBC	2003
New	Approved Basic #03-102734 BP	Plan: 2200	Rambler style SFR - 1997 UBC	2003
New	Approved Basic #03-102418 BP	Plan: South Carolina w/den	Two Story SFR - 1997 UBC	2003
New	Approved Basic #03-1066446 BP	Plan: Rainier 2	Two-story SFR - 1997UBC	2003
New	SFR with finished basement - 1997 UBC	Rainier Plan		2003
New	Two Story SFR - 1997 UBC			2003
New	27x66 2003 Skyline 6313			2003
New	Approved Basic #03-105764 BP	Plan: Cascade	SFR split level entry - 1997 UE	2003
New	Approved Basic #03-105768 BP	Plan: Rainier	Two-story SFR with 1042sf finishe	2003
New	Approved Basic #03-105768 BP	Plan: Rainier	Two-story SFR with 1042 sf finishe	2003
New	Approved Basic #03-105764 BP	Plan: Cascade	SFR split level entry - 1997 UBC	2003
New	Two Story SFR - 1997 UBC			2003
New	Two Story SFR with Attached Garage			2003
New	Rambler Style SFR - 1997 UBC			2003
New	Rambler Style SFR - 1997 UBC			2003
New	Two Story SFR - 1997 UBC			2003
New	Two Story SFR - 1997 UBC	Plan: 4145 AM		2003
New	Two Story SFR - 1997 UBC	Plan: 5055 A		2003
New	Two-story SFR with 3-car garage - 1997UBC			2003
New	Two Story SFR - 1997 UBC			2003
New	Two Story SFR with Attached Garage			2003
New	Approved Basic #03-102382 BP	Plan: 1974	Two Story SFR w/unfinished basement	2003
New	Two Story SFR with Attached Gargage			2003
New	2-story w/ 1042sf finished basement - 1997 UBC	Rainier 2		2003
New	Approved Basic #03-102987BP	Plan 2663	Two-story SFR - 1997UBC	2003
New	Two Story SFR - 1997 UBC			2003
New	Two Story SFR - 1997 UBC			2003



Accessory Dwelling Units

Index # - File Name: 1.0022 - Single Family Dwellings Data\_Snohomish County.pdf

New	SFR mid-entry - 1997UBC	Cascade Plan		2003
New	Approved Basic 03-102987BP	Plan 2663	Two-story SFR - 1997UBC	2003
New	Approved Basic 03-102977BP	Plan 2359	Two-story SFR - 1997UBC	2003
New	2-story SFR with Attached Garage			2003
New	Two Story SFR - 1997 UBC			2003
New	Rambler with Attached Garage			2003
New	Two Story SFR - 1997 UBC			2003
New	Two Story SFR with Attached Garage			2003
New	Two Story SFR - 1997 UBC			2003
New	Two-story SFR - 1997 UBC	Plan 3040A3F-0		2003
New	Approved Basic #00-109999 BP	Plan: 2063 A-1	Rambler Style SFR - 1997 UBC	2003
New	Approved Basic #02-103091BP	Plan: Whidbey/side entry	Two Story SFR - 1997 UBC	2003
New	Approved Basic #03-101010 BP	Plan: San Juan	Two Story SFR - 1997 UBC	2003
New	Approved Basic #02-100832 BP	Plan: 1455	Split Level SFR - 1997 UBC	2003
New	Approved Basic #02-100273 BP	Plan: 2117	Split Level SFR - 1997 UBC	Opti 2003
New	Approved Basic #02-100832 BP	Plan: 1455	Split Level SFR - 1997 UBC	C 2003
New	Two Story SFR - 1997 UBC			2003
New	2 story SFR w/attached garage			2003
New	Approved Basic #01-106757 BP	Plan: 706 - revised	Two Story SFR - 1997 UBC	2003
New	Approved Basic #01-106756 BP	Plan: 705 - revised	Two Story SFR - 1997 UBC	2003
New	Approved Basic #01-106754 BP	Plan: 703 - revised	Two Story SFR - 1997 UBC	2003
New	Approved Basic #01-106757 BP	Plan: 706 - revised	Two Story SFR - 1997 UBC	2003
New	Approved Basic #01-106753 BP	Plan: 702 revised	Two Story SFR - 1997 UBC	2003
New	Approved Basic #01-106757 BP	Plan: 706 - revised	Two Story SFR - 1997 UBC	2003
New	Two Story Duplex with Attached Garage			2003
New	Approved Basic #02-100273 BP	Plan: 2117	Split Level SFR - 1997 UBC	Opti 2003
New	Approved Basic #00-110867 BP	Plan: 552	Two Story SFR - 1997 UBC	2003
New	Approved Basic #01-105838 BP	Plan: 554 R	Two Story SFR.....1997 UBC	2003
New	Approved Basic #01-105843 BP	Plan: 556 R	Two style SFR.....1997 UBC	2003
New	Approved Basic #01-105842 BP	Plan: 555 R	Two Story SFR.....1997 UBC	2003
New	Approved Basic #00-110868 BP	Plan: 553 - revised	Two Story SFR - 1997 UBC	2003
New	Approved Basic #00-110867 BP	Plan: 552	Two Story SFR - 1997 UBC	2003
New	Approved Basic #00-110868 BP	Plan: 553 - revised	Two Story SFR - 1997 UBC	2003
New	Approved Basic #01-105842 BP	Plan: 555 R	Two Story SFR.....1997 UBC	2003
New	Approved Basic #00-110867 BP	Plan: 552	Two Story SFR - 1997 UBC	2003
New	Approved Basic #00-110868 BP	Plan: 553 - revised	Two Story SFR - 1997 UBC	2003
New	Approved Basic #01-105842 BP	Plan: 555 R	Two Story SFR.....1997 UBC	2003
New	Approved Basic #00-110867 BP	Plan: 552	Two Story SFR - 1997 UBC	2003
New	Approved Basic #00-110868 BP	Plan: 553 - revised	Two Story SFR - 1997 UBC	2003
New	Approved Basic #01-105843 BP	Plan: 556 R	Two style SFR.....1997 UBC	2003
New	Approved Basic #01-105838 BP	Plan: 554 R	Two Story SFR.....1997 UBC	2003
New	Approved Basic #01-105843 BP	Plan: 556 R	Two style SFR.....1997 UBC	2003
New	Approved Basic #01-105842 BP	Plan: 555 R	Two Story SFR.....1997 UBC	2003
New	Approved Basic #00-110868 BP	Plan: 553 - revised	Two Story SFR - 1997 UBC	2003
New	Approved Basic #00-110867 BP	Plan: 552	Two Story SFR - 1997 UBC	2003
New	Approved Basic #00-110868 BP	Plan: 553 - revised	Two Story SFR - 1997 UBC	2003
New	Approved Basic #00-110867 BP	Plan: 552	Two Story SFR - 1997 UBC	2003



Accessory Dwelling Units

Index # - File Name: 1.0022 - Single Family Dwellings Data\_Snohomish County.pdf

New	Rambler Style SFR - 1997 UBC		2003
New	Two-story SFR - 1997 UBC		2003
New	Rambler Style SFR - 1997 UBC		2003
New	Two-story SFR - 1997 UBC		2003
New	Rambler w/garage		2003
New	Approved Basic #03-104022 BP	Plan: 2675 Rambler Style SFR - 1997 UBC	2003
New	Approved Basic #03-102794 BP	Plan: 1966 - revised Rambler Style SFR - 1997 UBC	2003
New	Approved Basic #02-104896 BP	Plan: 2274 Rambler Style SFR - 1997 UBC	2003
New	Two Story SFR w/attached garage, over unfinished basement - 1997 UBC		2003
New	Two Story SFR with Attached Garage		2003
New	Approved Basic #02-104896 BP	Plan: 2274 Rambler Style SFR - 1997 UBC	2003
New	Two Story SFR with Attached Garage		2003
New	2-Story SFR w/attached garage.		2003
New	Two Story SFR - 1997 UBC		2003
New	2-Story SFR w/attached garage.		2003
New	Rambler w/finished basement & garage - 1997 UBC		2003
New	2-Story SFR w/attached garage.		2003
New	Rambler style SFR w/attached garages.		2003
New	2 story SFR with attached garage		2003
New	Two-story SFR - 1997 UBC		2003
New	2-Story SFR w/attached garage.		2003
New	Two-story SFR - 1997 UBC		2003
New	2 story SFR w/attached garage		2003
New	Approved Basic #03-109433 BP	Two Story SFR - 1997 UBC	2003
New	2 Story w. 3 Car Garage		2003
New	Two-story SFR - 1997 UBC		2003
New	Approved Basic #03-108590 BP	Plan: 3488 Two-story SFR - 1997 UBC	2003
New	Two Story SFR - 1997 UBC		2003
New	Approved Basic #99-113246 BP	Plan: 2632 Two Story SFR - 1997 UBC	2003
New	Two Story SFR - 1997 UBC	Plan: 2790	2003
New	Two Story SFR - 1997 UBC	Plan: 5911-F	2003
New	Approved Basic #98-150985BP	Plan # 5911E Two Story SFR - 1997 UBC	2003
New	Approved Basic #00-101994 BP	Plan: 2330 Two Story SFR - 1997 UBC	2003
New	Approved Basic #98-150984BP	Plan: 5911-B Two Story SFR - 1997 UBC	2003
New	Two Story SFR - 1997 UBC		2003
New	Rambler w/finished daylight basement & attached garage.		2003
New	Two Story SFR - 1997 UBC		2003
New	Approved Basic #02-100273 BP	Plan: 2117 Split Level SFR - 1997 UBC	Opti 2003
New	Approved Basic #02-100274 BP	Plan: 1710 Two Story SFR - 1997 UBC	Option 2003
New	Approved Basic #02-100274 BP	Plan: 1710 Two Story SFR - 1997 UBC	Option 2003
New	Approved Basic #01-106982 BP	Plan: 1705 crawl (revised) SFR w/finished lo	2003
New	Approved Basic #01-105212 BP	Plan: 1538 Two Story SFR - 1997 UBC	2003
New	Approved Basic #01-105212 BP	Plan: 1538 Two Story SFR - 1997 UBC	2003
New	Approved Basic #02-100274 BP	Plan: 1710 Two Story SFR - 1997 UBC	Option 2003
New	Approved Basic #01-105212 BP	Plan: 1538 Two Story SFR - 1997 UBC	2003
New	Approved Basic #02-100830 BP	Plan: 1686 Split Level SFR - 1997 UBC	2003
New	Approved Basic #01-105212 BP	Plan: 1538 Two Story SFR - 1997 UBC	2003

Accessory Dwelling Units

Index # - File Name: 1.0022 - Single Family Dwellings Data\_Snohomish County.pdf

New	Approved Basic #01-106982 BP	Plan: 1705 crawl (revised) SFR w/finished lo	2003
New	Approved Basic #02-100831 BP	Plan: 1755 Split Level SFR - 1997 UBC	2003
New	Approved Basic #02-100830 BP	Plan: 1686 Split Level SFR - 1997 UBC	2003
New	Approved Basic #02-100273 BP	Plan: 2117 Split Level SFR - 1997 UBC Opti	2003
New	Approved Basic #01-111402 BP	Plan: 1680-revised engineering Two-Story style SFR..	2003
New	Approved Basic #02-100274 BP	Plan: 1710 Two Story SFR - 1997 UBC Option	2003
New	Approved Basic #02-100273 BP	Plan: 2117 Split Level SFR - 1997 UBC Opti	2003
New	Approved Basic #01-105212 BP	Plan: 1538 Two Story SFR - 1997 UBC	2003
New	Approved Basic #01-105212 BP	Plan: 1538 Two Story SFR - 1997 UBC	2003
New	Approved Basic #01-106982 BP	Plan: 1705 crawl (revised) SFR w/finished lo	2003
New	Approved Basic #01-106982 BP	Plan: 1705 crawl (revised) SFR w/finished lo	2003
New	Approved Basic #01-105212 BP	Plan: 1538 Two Story SFR - 1997 UBC	2003
New	Approved Basic #02-100830 BP	Plan: 1686 Split Level SFR - 1997 UBC	2003
New	Approved Basic #01-105212 BP	Plan: 1538 Two Story SFR - 1997 UBC	2003
New	Approved Basic #01-105212 BP	Plan: 1538 Two Story SFR - 1997 UBC	2003
New	Approved Basic #02-107152 BP	Plan: 2741 A Two Story SFR - 1997 UBC	2003
New	Approved Basic #02-108413BP	Plan: 2006 Two-story SFR - 1997 UBC	2003
New	Approved Basic #02-107156 BP	Plan: 2155-A Two Story SFR - 1997 UBC	2003
New	Approved Basic #02-108413BP	Plan: 2006 Two-story SFR - 1997 UBC	2003
New	Approved Basic #02-107158 BP	Plan: 2373 A Two Story SFR - 1997 UBC	2003
New	Approved Basic #03-100209 BP	Plan: 2452 - Westcott - A Two Story SFR - 1997 UB	2003
New	Approved Basic #02-107152 BP	Plan: 2741 A Two Story SFR - 1997 UBC	2003
New	Approved Basic #02-107151 BP	Plan: 2565-B Two Story SFR - 1997 UBC	2003
New	Approved Basic #03-100209 BP	Plan: 2452 - Westcott - A Two Story SFR - 1997 UB	2003
New	Approved Basic #03-100209 BP	Plan: 2452 - Westcott - A Two Story SFR - 1997 UB	2003
New	Approved Basic #02-107156 BP	Plan: 2155-A Two Story SFR - 1997 UBC	2003
New	Approved Basic #02-107152 BP	Plan: 2741 A Two Story SFR - 1997 UBC	2003
New	Approved Basic #02-107151 BP	Plan: 2565-B Two Story SFR - 1997 UBC	2003
New	Approved Basic #02-108413BP	Plan: 2006 Two-story SFR - 1997 UBC	2003
New	Approved Basic #02-107151 BP	Plan: 2565-B Two Story SFR - 1997 UBC	2003
New	Approved Basic #02-107152 BP	Plan: 2741 A Two Story SFR - 1997 UBC	2003
New	Approved Basic #02-107151 BP	Plan: 2565-B Two Story SFR - 1997 UBC	2003
New	Approved Basic #02-107152 BP	Plan: 2741 A Two Story SFR - 1997 UBC	2003
New	Approved Basic #02-107152 BP	Plan: 2741 A Two Story SFR - 1997 UBC	2003
New	Approved Basic #02-107151 BP	Plan: 2565-B Two Story SFR - 1997 UBC	2003
New	Approved Basic #02-107154 BP	Plan: 2741 C Two Story SFR - 1997 UBC	2003
New	Approved Basic #02-107158 BP	Plan: 2373 A Two Story SFR - 1997 UBC	2003
New	Approved Basic #02-107152 BP	Plan: 2741 A Two Story SFR - 1997 UBC	2003
New	Approved Basic #02-107154 BP	Plan: 2741 C Two Story SFR - 1997 UBC	2003
New	Approved Basic #02-107151 BP	Plan: 2565-B Two Story SFR - 1997 UBC	2003
New	Approved Basic #02-107158 BP	Plan: 2373 A Two Story SFR - 1997 UBC	2003
New	Approved Basic #02-107154 BP	Plan: 2741 C Two Story SFR - 1997 UBC	2003
New	Approved Basic #02-107151 BP	Plan: 2565-B Two Story SFR - 1997 UBC	2003
New	Approved Basic #02-107152 BP	Plan: 2741 A Two Story SFR - 1997 UBC	2003
New	Approved Basic #02-107154 BP	Plan: 2741 C Two Story SFR - 1997 UBC	2003
New	Approved Basic #02-107155 BP	Plan: 2565-A Two Story SFR - 1997 UBC	2003
New	Approved Basic #02-107151 BP	Plan: 2565-B Two Story SFR - 1997 UBC	2003

Accessory Dwelling Units

Index # - File Name: 1.0022 - Single Family Dwellings Data\_Snohomish County.pdf

New	Approved Basic #02-108413BP	Plan: 2006 Two-story SFR - 1997 UBC	2003
New	Approved Basic #02-107157 BP	Plan: 2155-B Two Story SFR - 1997 UBC	2003
New	Approved Basic #02-107158 BP	Plan: 2373 A Two Story SFR - 1997 UBC	2003
New	Approved Basic #02-107156 BP	Plan: 2155-A Two Story SFR - 1997 UBC	2003
New	Approved Basic #02-107152 BP	Plan: 2741 A Two Story SFR - 1997 UBC	2003
New	Approved Basic #02-107158 BP	Plan: 2373 A Two Story SFR - 1997 UBC	2003
New	Approved Basic #03-106933 BP	Plan: 23025 SFR w/finished lower floor - 1997 UBC	2003
New	Approved Basic #03-106933 BP	Plan: 23025 SFR w/finished lower floor - 1997 UBC	2003
New	Two Story SFR - 1997 UBC	Plan: 2132	2003
New	Approved Basic #01-107401BP	Plan: 1520 Rambler Style SFR - 1997 UBC	2003
New	Approved Basic #01-107401BP	Plan: 1520 Rambler Style SFR - 1997 UBC	2003
New	Approved Basic #01-107401BP	Plan: 1520 Rambler Style SFR - 1997 UBC	2003
New	Approved Basic #01-107405 BP	Plan: 1446 Rambler Style SFR - 1997 UBC	2003
New	Approved Basic #01-107401BP	Plan: 1520 Rambler Style SFR - 1997 UBC	2003
New	Approved Basic #03-104635 BP	Plan: 2222 Two-story SFR - 1997 UBC	2003
New	Approved Basic #01-107401BP	Plan: 1520 Rambler Style SFR - 1997 UBC	2003
New	Approved Basic #01-107401BP	Plan: 1520 Rambler Style SFR - 1997 UBC	2003
New	Approved Basic #01-107401BP	Plan: 1520 Rambler Style SFR - 1997 UBC	2003
New	Approved Basic #01-107405 BP	Plan: 1446 Rambler Style SFR - 1997 UBC	2003
New	Approved Basic #01-107401BP	Plan: 1520 Rambler Style SFR - 1997 UBC	2003
New	Approved Basic #03-104635 BP	Plan: 2222 Two-story SFR - 1997 UBC	2003
New	Approved Basic #01-107401BP	Plan: 1520 Rambler Style SFR - 1997 UBC	2003
New	Approved Basic #01-107405 BP	Plan: 1446 Rambler Style SFR - 1997 UBC	2003
New	Approved Basic #01-107401BP	Plan: 1520 Rambler Style SFR - 1997 UBC	2003
New	Approved Basic #01-107401BP	Plan: 1520 Rambler Style SFR - 1997 UBC	2003
New	Approved Basic #01-107405 BP	Plan: 1446 Rambler Style SFR - 1997 UBC	2003
New	Approved Basic #03-104635 BP	Plan: 2222 Two-story SFR - 1997 UBC	2003
New	Approved Basic #01-107405 BP	Plan: 1446 Rambler Style SFR - 1997 UBC	2003
New	Two Story SFR with Attached Garage		2003
New	Approved Basic #01-107405 BP	Plan: 1446 Rambler Style SFR - 1997 UBC	2003
New	Approved Basic #01-107401BP	Plan: 1520 Rambler Style SFR - 1997 UBC	2003
New	Approved Basic #01-107401BP	Plan: 1520 Rambler Style SFR - 1997 UBC	2003
New	Approved Basic #01-107405 BP	Plan: 1446 Rambler Style SFR - 1997 UBC	2003
New	Approved Basic #01-107405 BP	Plan: 1446 Rambler Style SFR - 1997 UBC	2003
New	Approved Basic #01-107405 BP	Plan: 1446 Rambler Style SFR - 1997 UBC	2003
New	Approved Basic #03-104635 BP	Plan: 2222 Two-story SFR - 1997 UBC	2003
New	Approved Basic #03-104635 BP	Plan: 2222 Two-story SFR - 1997 UBC	2003
New	Approved Basic #03-104635 BP	Plan: 2222 Two-story SFR - 1997 UBC	2003
New	Approved Basic #01-107405 BP	Plan: 1446 Rambler Style SFR - 1997 UBC	2003
New	Two Story SFR - 1997 UBC	Plan: 4010 D-B-LG	2003
New	Two Story SFR - 1997 UBC	Plan: 5022 F-C	2003
New	Two Story SFR - 1997 UBC	Plan: 4008 C-RGD	2003
New	Two Story SFR - 1997 UBC	Plan: 4111-B	2003
New	Two Story SFR - 1997 UBC	Plan: 3012-C	2003
New	Two Story SFR - 1997 UBC	Plan: 3011 B-A-G	2003
New	2-Story SFR w/attached garage.		2003
New	Two Story SFR - 1997 UBC	Plan: 3010 A	2003

Accessory Dwelling Units

Index # - File Name: 1.0022 - Single Family Dwellings Data\_Snohomish County.pdf

New	Two Story SFR - 1997 UBC	Plan: 4020 A	2003
New	Two Story SFR - 1997 UBC	Plan: 5022 BF-B	2003
New	Two Story SFR - 1997 UBC	Plan: 4008-C-RG	2003
New	Two Story SFR - 1997 UBC	Plan: 5022 F-C-R	2003
New	Two Story SFR - 1997 UBC	Plan: 4010 DB-B-L	2003
New	Two Story SFR - 1997 UBC	Plan: 4002 B-A-RG	2003
New	Two Story SFR - 1997 UBC	Plan: 3010 C-LG	2003
New	Two Story SFR - 1997 UBC	Plan: 5022 FB-B-L	2003
New	Two Story SFR - 1997 UBC	Plan: 4111 - A - LX	2003
New	Two Story SFR - 1997 UBC	Plan: 3010	2003
New	Two Story SFR - 1997 UBC	Plan: 4020	2003
New	Two Story SFR - 1997 UBC	Plan: 4111	2003
New	Two Story SFR - 1997 UBC	Plan: 3011 B-B	2003
New	Two Story SFR - 1997 UBC	Plan: 4010 D-B-LG	2003
New	Two Story SFR - 1997 UBC	Plan: 4002 B-B	2003
New	Two Story SFR - 1997 UBC	Plan: 5022 B	2003
New	Two Story SFR - 1997 UBC	Plan: 5022 F	2003
New	Two Story SFR - 1997 UBC	Plan: 4002 - B - G	2003
New	Two Story SFR - 1997 UBC	Plan: 4008 - B - G	2003
New	2-story SFR w/attached garage.		2003
New	42 x 60 - 2003 - Fleetwood		2003
New	SFR w/unfinished basement - 1997 UBC	See comment 6/28/2007	2003
New	Approved Basic #03-101155 BP	Plan #2188 side load Two Story SFR - 1997 UBC	2003
New	Approved Basic #03-101155 BP	Plan #2188 side load Two Story SFR - 1997 UBC	2003
New	Approved Basic #03-102417 BP	Plan: North Carolina w/den Two Story SFR - 1997 UBC	2003
New	Two Story SFR - 1997 UBC	Plan: 2415	2003
New	Approved Basic #03-104080 BP	Plan: M2415 A3F-3 Two Story SFR - 1997 UBC	2003
New	Approved Basic #03-102418 BP	Plan: South Carolina w/den Two Story SFR - 1997 UBC	2003
New	Approved Basic #03-104080 BP	Plan: M2415 A3F-3 Two Story SFR - 1997 UBC	2003
New	Approved Basic #03-104080 BP	Plan: M2415 A3F-3 Two Story SFR - 1997 UBC	2003
New	Two Story SFR - 1997 UBC	Plan: Vermont w/Den	2003
New	Rambler w/ garage		2003
New	Approved Basic #100446 BP	Plan: 2838 Two Story SFR - 1997 UBC	2003
New	Approved Basic #01-111494 BP	Bldr Plan SSI 2792 Two-story style SFR....1997 UBC	2003
New	Approved Basic #01-104100 BP	Plan SSI/2497 Two story SFR w/attached garage	2003
New	Approved Basic #01-104100 BP	Plan SSI/2497 Two story SFR w/attached garage	2003
New	Approved Basic #01-101542 BP	Plan: 2349 (56 -2656) Rambler Style SFR - 1997 UBC	2003
New	Approved Basic #01-111494 BP	Bldr Plan SSI 2792 Two-story style SFR....1997 UBC	2003
New	Approved Basic #98-150633BP	Plan: 2555 Two Story SFR - 1997 UBC	2003
New	Approved Basic #01-101541BP	Plan: 2877 Two Story SFR - 1997 UBC	2003
New	Two Story SFR w/finished basement - 1997 UBC	Plan: 4690	2003
New	Approved Basic #02-109212 BP	Plan: 2797 Two Story SFR - 1997 UBC	2003
New	Approved Basic #98-150628 BP	Plan: 50 er Two Story SFR - 1997 UBC	2003
New	One-story SFR with unfinished daylight basement - 1997UBC		2003
New	Rambler Style SFR - 1997 UBC		2003
New	Approved Basic #02-110232 BP	Plan: 1944 Two Story SFR - 1997 UBC	2003
New	Approved Basic #02-110237 BP	Plan: 2311 Two Story SFR - 1997 UBC	2003

Accessory Dwelling Units

Index # - File Name: 1.0022 - Single Family Dwellings Data\_Snohomish County.pdf

New	Approved Basic #01-112969 BP	Plan No. 2321	Mid-entry SFR - 1997 UBC	2003
New	Approved Basic #02-110237 BP	Plan: 2311	Two Story SFR - 1997 UBC	2003
New	Approved Basic #02-110232 BP	Plan: 1944	Two Story SFR - 1997 UBC	2003
New	Approved Basic Plan 03-104873BP	Plan 1926-E	Split-level entry SFR - 1997UBC	2003
New	Approved Basic #01-107312 BP	Plan: 1731	Two Story SFR - 1997 UBC	2003
New	Approved Basic #01-107312 BP	Plan: 1731	Two Story SFR - 1997 UBC	2003
New	Rambler Style SFR - 1997 UBC, 20 psf Snow load area			2003
New	One-story SFR w/finished basement - 1997 UBC			2003
New	Approved Basic #03-105650 BP	Plan E	Two Story SFR - 1997 UBC	2003
New	Two Story SFR - 1997 UBC	Plan: C		2003
New	Two Story SFR - 1997 UBC	Plan: B		2003
New	Two Story SFR - 1997 UBC	Plan: D		2003
New	Approved Basic #03-105215 BP	Plan: D	Two Story SFR - 1997 UBC	2003
New	2-story SFR w/garage			2003
New	Rambler Style SFR - 1997 UBC	Plan: A		2003
New	Approved Basic #03-105075 BP	Plan: A	Rambler Style SFR - 1997 UBC	2003
New	Two Story SFR - 1997 UBC	Plan: C-4		2003
New	Approved Basic #03-105075 BP	Plan: A	Rambler Style SFR - 1997 UBC	2003
New	Approved Basic #03-105075 BP	Plan: A	Rambler Style SFR - 1997 UBC	2003
New	Approved Basic #03-105077 BP	Plan: B	Two Story SFR - 1997 UBC	2003
New	Approved Basic #03-105075 BP	Plan: A	Rambler Style SFR - 1997 UBC	2003
New	Approved Basic #03-105076 BP	Plan: C-4	Two Story SFR - 1997 UBC	2003
New	Approved Basic #03-105077 BP	Plan: B	Two Story SFR - 1997 UBC	2003
New	Approved Basic #03-105077 BP	Plan: B	Two Story SFR - 1997 UBC	2003
New	Approved Basic #03-105078 BP	Plan: C	Two Story SFR - 1997 UBC	2003
New	Approved Basic #03-105215 BP	Plan: D	Two Story SFR - 1997 UBC	2003
New	Approved Basic #03-105650 BP	Plan E	Two Story SFR - 1997 UBC	2003
New	Approved Basic #03-105650 BP	Plan E	Two Story SFR - 1997 UBC	2003
New	Approved Basic #02-100274 BP	Plan: 1710	Two Story SFR - 1997 UBC	Option 2003
New	Approved Basic #02-100273 BP	Plan: 2117	Split Level SFR - 1997 UBC	Opti 2003
New	Approved Basic #02-109388 BP	Plan: 1575	Tri-Level SFR - 1997 UBC	Opt 2003
New	Approved Basic #03-104421 BP	Plan: 1447	Rambler Style SFR - 1997 UBC	2003
New	Approved Basic #03-105143 BP	Plan #J2060	Two Story SFR - 1997 UBC	2003
New	Approved Basic #03-104421 BP	Plan: 1447	Rambler Style SFR - 1997 UBC	2003
New	Approved Basic #02-100274 BP	Plan: 1710	Two Story SFR - 1997 UBC	Option 2003
New	Approved Basic #02-100273 BP	Plan: 2117	Split Level SFR - 1997 UBC	Opti 2003
New	Approved Basic #02-100832 BP	Plan: 1455	Split Level SFR - 1997 UBC	2003
New	Approved Basic #02-100274 BP	Plan: 1710	Two Story SFR - 1997 UBC	Option 2003
New	2 story SFR w/attached garage - 1997 UBC	Plan: 1703	Tri	2003
New	Approved Basic #02-100273 BP	Plan: 2117	Split Level SFR - 1997 UBC	Opti 2003
New	Approved Basic #02-100832 BP	Plan: 1455	Split Level SFR - 1997 UBC	2003
New	Approved Basic #02-100273 BP	Plan: 2117	Split Level SFR - 1997 UBC	Opti 2003
New	Approved Basic #02-109388 BP	Plan: 1575	Tri-Level SFR - 1997 UBC	Opt 2003
New	Approved Basic #01-111402 BP	Plan: 1680-revised engineering	Two-Story style SFR..	2003
New	Approved Basic #03-109315 BP	Plan: 1575 BSMT	Two Story SFR w/ finished basement-	2003
New	Approved Basic #02-100274 BP	Plan: 1710	Two Story SFR - 1997 UBC	Option 2003
New	Approved Basic #03-105143 BP	Plan # J2060	Two Story SFR - 1997 UBC	2003

Accessory Dwelling Units

Index # - File Name: 1.0022 - Single Family Dwellings Data\_Snohomish County.pdf

New	Approved Basic #02-100274 BP	Plan: 1710	Two Story SFR - 1997 UBC	Option	2003
New	Approved Basic #02-100273 BP	Plan: 2117	Split Level SFR - 1997 UBC	Opti	2003
New	Approved Basic #03-109315 BP	Plan: 1575 BSMT	Two Story SFR w/ finished basement-		2003
New	Approved Basic #02-100273 BP	Plan: 2117	Split Level SFR - 1997 UBC	Opti	2003
New	Approved Basic #02-100832 BP	Plan: 1455	Split Level SFR - 1997 UBC		2003
New	Approved Basic #02-100274 BP	Plan: 1710	Two Story SFR - 1997 UBC	Option	2003
New	Approved Basic #02-100273 BP	Plan: 2117	Split Level SFR - 1997 UBC	Opti	2003
New	Approved Basic #02-100274 BP	Plan: 1710	Two Story SFR - 1997 UBC	Option	2003
New	Approved Basic #02-109388 BP	Plan: 1575	Tri-Level SFR - 1997 UBC	Opt	2003
New	Approved Basic #02-100832 BP	Plan: 1455	Split Level SFR - 1997 UBC		2003
New	Approved Basic #02-100832 BP	Plan: 1455	Split Level SFR - 1997 UBC		2003
New	Approved Basic #02-100273 BP	Plan: 2117	Split Level SFR - 1997 UBC	Opti	2003
New	Approved Basic #02-109388 BP	Plan: 1575	Tri-Level SFR - 1997 UBC	Opt	2003
New	Rambler w/ semi finished daylight basement				2003
New	2 story sfr w/attached garage				2003
New	Approved Basic #03-105078 BP	Plan: C	Two Story SFR - 1997 UBC		2003
New	Two Story SFR - 1997 UBC	Plan: E			2003
New	Approved Basic 03-109466 BP	Plan:D1703	Two Story SFR - 1997 UBC		2003
New	Two Story SFR w/finished basement -1997 UBC	Plan:1575-4 level			2003
New	Approved Basic #02-100273 BP	Plan: 2117	Split Level SFR - 1997 UBC	Opti	2003
New	Approved Basic #02-100274 BP	Plan: 1710	Two Story SFR - 1997 UBC	Option	2003
New	Approved Basic #02-100832 BP	Plan: 1455	Split Level SFR - 1997 UBC		2003
New	Approved Basic #02-100273 BP	Plan: 2117	Split Level SFR - 1997 UBC	Opti	2003
New	Approved Basic #02-109388 BP	Plan: 1575	Tri-Level SFR - 1997 UBC	Opt	2003
New	Two Story SFR - 1997 UBC				2003
New	Approved Basic #02-100274 BP	Plan: 1710	Two Story SFR - 1997 UBC	Option	2003
New	Two-story duplex - 1997UBC	Plan: Duplex 1337			2003
New	Approved Basic #01-110578 BP	Plan: 2590 A	Two Story SFR - 1997 UBC		2003
New	Approved Basic #01-110578 BP	Plan: 2590 A	Two Story SFR - 1997 UBC		2003
New	Approved Basic #02-100274 BP	Plan: 1710	Two Story SFR - 1997 UBC	Option	2003
New	Two Story SFR - 1997 UBC				2003
New	Approved Basic #03-103390 BP	Plan M2535A3F-1	Two-story SFR with 3-car ga		2003
New	2-Story SFR w/finished daylight basement & attached garage.				2003
New	SFR with Semi-Finished Basement and Attached Garage				2003
New	2312 sq ft Rambler with Attached Garage.				2003
New	SFR w/attached garage 1997 UBC				2003
New	27 x 68 -2003- Fleetwood-Berkshire XLE				2003
New	Approved Basic #03-103164 BP	Plan: 20084	Rambler Style SFR - 1997 UBC		2003
New	Two-story Duplex - 1997 UBC				2003
New	Approved Basic #02-110377 BP	Plan 2006	Two Story SFR - 1997 UBC		2003
New	Approved Basic #02-103159 BP	Plan: 2180 SSI	Two Story SFR....1997 UBC		2003
New	Approved Basic #02-110008 BP	Plan 2024	Two-story SFR - 1997 UBC		2003
New	Approved Basic #02-110008 BP	Plan 2024	Two-story SFR - 1997 UBC		2003
New	Approved Basic #02-110377 BP	Plan 2006	Two Story SFR - 1997 UBC		2003
New	Approved Basic #02-103159 BP	Plan: 2180 SSI	Two Story SFR....1997 UBC		2003
New	Approved Basic #02-110377 BP	Plan 2006	Two Story SFR - 1997 UBC		2003
New	Approved Basic #01-107262 BP	Plan: 2342	Two-story SFR - 1997 UBC		2003



Accessory Dwelling Units

Index # - File Name: 1.0022 - Single Family Dwellings Data\_Snohomish County.pdf

New	Approved Basic #02-110377 BP	Plan 2006	Two Story SFR - 1997 UBC	2003
New	Approved Basic #02-110008 BP	Plan 2024	Two-story SFR - 1997 UBC	2003
New	Approved Basic #02-110008 BP	Plan 2024	Two-story SFR - 1997 UBC	2003
New	Approved Basic #02-103159 BP	Plan: 2180 SSI	Two Story SFR....1997 UBC	2003
New	Approved Basic #02-110377 BP	Plan 2006	Two Story SFR - 1997 UBC	2003
New	Approved Basic #02-110377 BP	Plan 2006	Two Story SFR - 1997 UBC	2003
New	Approved Basic #02-103159 BP	Plan: 2180 SSI	Two Story SFR....1997 UBC	2003
New	Approved Basic #02-103159 BP	Plan: 2180 SSI	Two Story SFR....1997 UBC	2003
New	Approved Basic #02-110377 BP	Plan 2006	Two Story SFR - 1997 UBC	2003
New	Approved Basic #02-103159 BP	Plan: 2180 SSI	Two Story SFR....1997 UBC	2003
New	Approved Basic #02-110377 BP	Plan 2006	Two Story SFR - 1997 UBC	2003
New	Approved Basic #02-110377 BP	Plan 2006	Two Story SFR - 1997 UBC	2003
New	Approved Basic #02-103159 BP	Plan: 2180 SSI	Two Story SFR....1997 UBC	2003
New	Approved Basic #02-110377 BP	Plan 2006	Two Story SFR - 1997 UBC	2003
New	Approved Basic #02-103159 BP	Plan: 2180 SSI	Two Story SFR....1997 UBC	2003
New	Approved Basic #02-110377 BP	Plan 2006	Two Story SFR - 1997 UBC	2003
New	Approved Basic #02-110008 BP	Plan 2024	Two-story SFR - 1997 UBC	2003
New	Approved Basic #02-110008 BP	Plan 2024	Two-story SFR - 1997 UBC	2003
New	Approved Basic #02-103159 BP	Plan: 2180 SSI	Two Story SFR....1997 UBC	2003
New	Approved Basic #02-110377 BP	Plan 2006	Two Story SFR - 1997 UBC	2003
New	Approved Basic #02-103159 BP	Plan: 2180 SSI	Two Story SFR....1997 UBC	2003
New	Approved Basic #02-110377 BP	Plan 2006	Two Story SFR - 1997 UBC	2003
New	Approved Basic #01-107262 BP	Plan: 2342	Two Story SFR....1997 UBC	2003
New	Approved Basic #02-110377 BP	Plan 2006	Two Story SFR - 1997 UBC	2003
New	Approved Basic #03-110681 BP	Plan: 1706	Two Story SFR - 1997 UBC	2003
New	Approved Basic #02-103157 BP	Plan No. 2108 SSI	Two Story SFR - 1997 UBC	2003
New	Approved Basic #02-103159 BP	Plan: 2180 SSI	Two Story SFR....1997 UBC	2003
New	Two Story SFR - 1997 UBC	Plan: 1706		2003
New	Approved Basic #02-110008 BP	Plan 2024	Two-story SFR - 1997 UBC	2003
New	Two Story Duplex - 1997 UBC			2003
New	Approved Basic 03-106090BP	Plan: Nantucket/1142-03	Two-story SFR - 1997U	2003
New	Approved Basic 03-106085 BP	Plan: Berkshire 2232-02	Two-story SFR - 1997UBC v	2003
New	Two Story SFR - 1997 UBC	Plan: Rochester / 2345		2003
New	Two Story SFR - 1997 UBC	Plan: Nantucket/ 1142-03		2003
New	Two Story SFR - 1997 UBC	Plan: Camden / 2261		2003
New	Two Story SFR - 1997 UBC	Plan: Berkshire/2232-02		2003
New	Two Story SFR - 1997 UBC	Plan: Sterling II		2003
New	Two Story Duplex - 1997 UBC	Plan: GB 29		2003
New	Split level-Mid Entry SFR			2003
New	28x56, 2003 Marlette			2003
New	Approved Basic #01-106553 BP	Plan # R2420B3GB	Rambler Style SFR - 1997 UBC	2003
New	Approved Basic #03-104807 BP	Plan: Camden/2261	Two Story SFR - 1997 UBC	2003
New	Two Story SFR with Attached Garage			2003
New	Rambler Style SFR -1997 UBC			2003
New	Approved Basic #03-108821 BP	Plan: 1228 - Gable	Rambler Style SFR - 1997 UBC	2003
New	Rambler Style SFR - 1997 UBC	Plan: 1228		2003
New	26x64 2003 Nashua 702			2003

Accessory Dwelling Units

Index # - File Name: 1.0022 - Single Family Dwellings Data\_Snohomish County.pdf

New	Two Story SFR - 1997 UBC		2003
New	Two Story SFR - 1997 UBC		2003
New	Rambler w/ 3 Car - 1997 UBC		2003
New	Approved Basic #03-104592BP	Plan 2003 Rambler Style SFR - 1997 UBC	2003
New	Two Story SFR - 1997 UBC	Plan: 2516	2003
New	Two Story SFR - 1997 UBC	Plan: 2516	2003
New	Two Story SFR - 1997 UBC	Plan: 2297	2003
New	28x64 (2003) Marlette		2003
New	Two-story SFR - 1997 UBC	Plan: B2A	2003
New	Two Story SFR - 1997 UBC	Plan B3A	2003
New	2-Story SFR over unfin. basement w/attached garage.		2003
New	Two Story SFR - 1997 UBC		2003
New	Approved Basic #03-105121 BP	Plan: B2a Two-story SFR - 1997 UBC	2003
New	Approved Basic #03-105119 BP	Plan: B1b Two-story SFR - 1997 UBC	2003
New	Approved Basic #03-105123 BP	Plan: B3a Two-story SFR - 1997 UBC	2003
New	Rambler Style SFR - 1997 UBC	Plan: B 4a	2003
New	Approved Basic #03-105119 BP	Plan: B1b Two-story SFR - 1997 UBC	2003
New	Two Story SFR - 1997 UBC	Plan: D1a	2003
New	Two Story SFR - 1997 UBC	Plan: B-1b	2003
New	Approved Basic #03-105121 BP	Plan: B2a Two-story SFR - 1997 UBC	2003
New	Approved Basic #03-105123 BP	Plan: B3a Two-story SFR - 1997 UBC	2003
New	Approved Basic #03-102958 BP	Plan: B-1a Two-story SFR - 1997 UBC	2003
New	Two Story SFR - 1997 UBC	Plan: A1-A	2003
New	Approved Basic 03-102959BP	Plan A2a Two-story SFR - 1997 UBC	2003
New	Two Story SFR - 1997 UBC	Plan: B-5	2003
New	Approved Basic #03-105121 BP	Plan: B2a Two-story SFR - 1997 UBC	2003
New	Approved Basic #03-105123 BP	Plan: B3a Two-story SFR - 1997 UBC	2003
New	Approved Basic #03-105121 BP	Plan: B2a Two-story SFR - 1997 UBC	2003
New	Approved Basic #03-105123 BP	Plan: B3a Two-story SFR - 1997 UBC	2003
New	Approved Basic #03-105123 BP	Plan: B3a Two-story SFR - 1997 UBC	2003
New	Approved Basic 03-102960 BP	Plan: D1a Two-story SFR - 1997 UBC	2003
New	Approved Basic #02-110377 BP	Plan 2006 Two Story SFR - 1997 UBC	2003
New	Approved Basic #02-110005 BP	Plan 1784 Rambler-style SFR - 1997 UBC	C 2003
New	Approved Basic #02-110005 BP	Plan 1784 Rambler-style SFR - 1997 UBC	C 2003
New	Approved Basic #02-103159 BP	Plan: 2180 SSI Two Story SFR....1997 UBC	2003
New	Approved Basic #02-110005 BP	Plan 1784 Rambler-style SFR - 1997 UBC	C 2003
New	Approved Basic #02-110377 BP	Plan 2006 Two Story SFR - 1997 UBC	2003
New	Approved Basic #02-103159 BP	Plan: 2180 SSI Two Story SFR....1997 UBC	2003
New	Approved Basic #02-110377 BP	Plan 2006 Two Story SFR - 1997 UBC	2003
New	Approved Basic #02-110005 BP	Plan 1784 Rambler-style SFR - 1997 UBC	C 2003
New	Approved Basic #02-110377 BP	Plan 2006 Two Story SFR - 1997 UBC	2003
New	Approved Basic #02-103159 BP	Plan: 2180 SSI Two Story SFR....1997 UBC	2003
New	Approved Basic #02-110377 BP	Plan 2006 Two Story SFR - 1997 UBC	2003
New	Approved Basic #02-103159 BP	Plan: 2180 SSI Two Story SFR....1997 UBC	2003
New	Approved Basic #02-110377 BP	Plan 2006 Two Story SFR - 1997 UBC	2003
New	Approved Basic #03-110681 BP	Plan: 1706 Two Story SFR - 1997 UBC	2003
New	Approved Basic #02-110377 BP	Plan 2006 Two Story SFR - 1997 UBC	2003

Accessory Dwelling Units

Index # - File Name: 1.0022 - Single Family Dwellings Data\_Snohomish County.pdf

New	Approved Basic #02-110008 BP	Plan 2024	Two-story SFR - 1997 UBC	2003
New	Approved Basic #02-110008 BP	Plan 2024	Two-story SFR - 1997 UBC	2003
New	Approved Basic #02-103157 BP	Plan No. 2108 SSI	Two Story SFR - 1997 UBC	2003
New	Approved Basic #02-103157 BP	Plan No. 2108 SSI	Two Story SFR - 1997 UBC	2003
New	Approved Basic #02-103159 BP	Plan: 2180 SSI	Two Story SFR....1997 UBC	2003
New	Approved Basic #02-103157 BP	Plan No. 2108 SSI	Two Story SFR - 1997 UBC	2003
New	Approved Basic #02-110377 BP	Plan 2006	Two Story SFR - 1997 UBC	2003
New	Approved Basic #02-103157 BP	Plan No. 2108 SSI	Two Story SFR - 1997 UBC	2003
New	Approved Basic #02-110008 BP	Plan 2024	Two-story SFR - 1997 UBC	2003
New	Approved Basic #02-110008 BP	Plan 2024	Two-story SFR - 1997 UBC	2003
New	Approved Basic #02-103159 BP	Plan: 2180 SSI	Two Story SFR....1997 UBC	2003
New	Approved Basic #02-110377 BP	Plan 2006	Two Story SFR - 1997 UBC	2003
New	Approved Basic #02-103157 BP	Plan No. 2108 SSI	Two Story SFR - 1997 UBC	2003
New	Approved Basic #02-103157 BP	Plan No. 2108 SSI	Two Story SFR - 1997 UBC	2003
New	Approved Basic #02-103157 BP	Plan No. 2108 SSI	Two Story SFR - 1997 UBC	2003
New	Approved Basic #02-103159 BP	Plan: 2180 SSI	Two Story SFR....1997 UBC	2003
New	Approved Basic #02-110377 BP	Plan 2006	Two Story SFR - 1997 UBC	2003
New	Approved Basic #02-110008 BP	Plan 2024	Two-story SFR - 1997 UBC	2003
New	Approved Basic #03-110681 BP	Plan: 1706	Two Story SFR - 1997 UBC	2003
New	Approved Basic #02-103157 BP	Plan No. 2108 SSI	Two Story SFR - 1997 UBC	2003
New	Approved Basic #02-103159 BP	Plan: 2180 SSI	Two Story SFR....1997 UBC	2003
New	Approved Basic #02-110377 BP	Plan 2006	Two Story SFR - 1997 UBC	2003
New	Approved Basic #02-103158 BP	Plan: 2342 SSI	Two Story SFR....1997 UBC	2003
New	Approved Basic #02-103157 BP	Plan No. 2108 SSI	Two Story SFR - 1997 UBC	2003
New	Approved Basic #02-110377 BP	Plan 2006	Two Story SFR - 1997 UBC	2003
New	Approved Basic #02-110377 BP	Plan 2006	Two Story SFR - 1997 UBC	2003
New	Approved Basic #02-110377 BP	Plan 2006	Two Story SFR - 1997 UBC	2003
New	Approved Basic #02-103159 BP	Plan: 2180 SSI	Two Story SFR....1997 UBC	2003
New	Approved Basic #02-103159 BP	Plan: 2180 SSI	Two Story SFR....1997 UBC	2003
New	Approved Basic #02-110377 BP	Plan 2006	Two Story SFR - 1997 UBC	2003
New	2003 Oakwood Yorkshire 27 x 52			2003
New	One-story SFR - 1997 UBC			2003
New	Approved Basic #03-105122 BP	Plan: A1a	Two-story SFR - 1997 UBC	2003
New	Rambler Style SFR - 1997 UBC			2003
New	SFR with semi-finished basement and attached garage			2003
New	One-story SFR w/unfinished basement			2003
New	Split Entry with 1 Car			2003
New	Approved Basic #02-110377 BP	Plan 2006	Two Story SFR - 1997 UBC	2003
New	Approved Basic #02-110377 BP	Plan 2006	Two Story SFR - 1997 UBC	2003
New	Approved Basic #02-103159 BP	Plan: 2180 SSI	Two Story SFR....1997 UBC	2003
New	Approved Basic #02-110377 BP	Plan 2006	Two Story SFR - 1997 UBC	2003
New	Two-story SFR w/finished garage			2003
New	Approved Basic #02-110377 BP	Plan 2006	Two Story SFR - 1997 UBC	2003
New	Approved Basic #02-110005 BP	Plan 1784	Rambler-style SFR - 1997 UBC	C 2003
New	Story SFR Above Attached Garage - 1997 UBC			2003
New	Two Story SFR - 1997 UBC	Plan: 3000 A		2003
New	Two Story SFR - 1997 UBC	Plan: 2493 -B		2003

Accessory Dwelling Units

Index # - File Name: 1.0022 - Single Family Dwellings Data\_Snohomish County.pdf

New	Two Story SFR - 1997 UBC	Plan: 2842 - B	2003
New	Two Story SFR - 1997 UBC	Plan: 2355-A	2003
New	Approved Basic #03-108827 BP	Plan: 2842 - A Two Story SFR - 1997 UBC	2003
New	Approved Basic #03-109293 BP	Plan: 2996 B Two Story SFR - 1997 UBC	2003
New	Approved Basic #02-109124 BP	Plan: 1214 SFR w/semi-finished lower floor - 1997	2003
New	Two Story SFR - 1997 UBC	Plan 3095	2003
New	Two Story SFR - 1997 UBC	Plan: 2355 -B	2003
New	Two Story SFR - 1997 UBC		2003
New	Approved Basic #03-108237 BP	Two Story Duplex - 1997 UBC	2003
New	Approved Basic #03-108237 BP	Two Story Duplex - 1997 UBC	2003
New	Two Story Duplex - 1997 UBC		2003
New	Two Story Duplex - 1997 UBC		2003
New	Approved Basic #03-108237 BP	Two Story Duplex - 1997 UBC	2003
New	2 Story w/ 2 Car & Bonus Room Above Garage		2003
New	Approved Basic #03-109258 BP	Plan: 3000 A Two Story SFR - 1997 UBC	2003
New	Two Story SFR - 1997 UBC	Plan: 2996 A	2003
New	Two Story SFR - 1997 UBC	Plan: 2996 B	2003
New	Approved Basic #03-107117 BP	Plan: 1631 Two Story SFR - 1997 UBC	2003
New	Approved Basic #03-107115 BP	Plan: 1932 SFRw/semi-finsihed basement - 1997 L	2003
New	Approved Basic #03-107116 BP	Plan: 1257 Rambler Style SFR- 1997 UBC	2003
New	Approved Basic #03-107115 BP	Plan: 1932 SFRw/semi-finsihed basement - 1997 L	2003
New	Approved Basic #03-109535 BP	Plan #1829 Two Story SFR - 1997 UBC	2003
New	Approved Basic #99-103777BP	Plan: 2415 A/3 Two Story SFR - 1997 UBC	2003
New	Approved Basic #00-100924 BP	Plan: 2405 Two Story SFR - 1997 UBC	2003
New	Approved Basic #99-103777BP	Plan: 2415 A/3 Two Story SFR - 1997 UBC	2003
New	Approved Basic #03-106818 BP	Plan: 2896 Two-story SFR - 1997 UBC	2003
New	Two Story SFR w/atached garage. - 1997 UBC	Plan: 2630 (Elev. A)	2003
New	Two Story SFR w/attached garage	Plan: 2630 (Elev. B)	2003
New	Two Story SFR - 1997 UBC	Plan: 2830	2003
New	Two Story SFR - 1997 UBC	Plan: 2896	2003
New	Two Story SFR - 1997 UBC		2003
New	Approved Basic #03-106818 BP	Plan: 2896 Two-story SFR - 1997 UBC	2003
New	Approved Basic #02-108950 BP	Plan: 2780 Two Story SFR - 1997 UBC	2003
New	Approved Basic #99-103777BP	Plan: 2415 A/3 Two Story SFR - 1997 UBC	2003
New	Approved Basic #02-108950 BP	Plan: 2780 Two Story SFR - 1997 UBC	2003
New	Two Story SFR - 1997 UBC		2003
New	Rambler-style SFR - 1997UBC		2003
New	Approved Basic #02-107746 BP	Plan: 1317 Duplex Two Story Duplex - 1997 UBC	2003
New	Two-story SFR with 1196sf attached garage - 1997UBC		2003
New	Two Story SFR - 1997 UBC		2003
New	Two Story SFR with Unfinished Basement - 1997 UBC		2003
New	Two Story SFR - 1997 UBC	Plan: 2425	2003
New	Two Story SFR - 1997 UBC	Plan: 2402	2003
New	Rambler Style SFR - 1997 UBC		2003
New	Rambler Style SFR - 1997 UBC		2003
New	Rambler Style SFR - 1997 UBC		2003
New	Rambler Style SFR - 1997 UBC		2003

Accessory Dwelling Units

Index # - File Name: 1.0022 - Single Family Dwellings Data\_Snohomish County.pdf

New	Approved Basic #03-108774 BP	Plan #2402	Two Story SFR - 1997 UBC	2003
New	Approved Basic #03-108774 BP	Plan #2402	Two Story SFR - 1997 UBC	2003
New	Rambler Style SFR - 1997 UBC			2003
New	Two-story SFR			2003
New	2-story SFR w/garage			2003
New	Two-story SFR - 1997 UBC			2003
New	27 X 70 Silvercrest Classic 2003			2003
New	Two-story SFR - 1997 UBC			2003
New	Two-story SFR - 1997 UBC			2003
New	Two-story SFR - 1997 UBC			2003
New	Rambler Style SFR - 1997 UBC			2003
New	Two Story SFR - 1997 UBC			2003
New	Two Story SFR - 1997 UBC	Plan: The Orcas		2003
New	Two Story SFR - 1997 UBC	Plan: 2516		2003
New	Approved Basic #99-103777BP	Plan: 2415 A/3	Two Story SFR - 1997 UBC	2003
New	Approved Basic #03-107633 BP	Plan: The Orcas	Two Story SFR - 1997 UBC	2003
New	Two Story SFR - 1997 UBC	Plan: 2366 B		2003
New	Approved Basic #00-110406 BP	Plan: 2415/pony wall revision	Two Story SFR - 1997 U	2003
New	Two Story SFR w/attached Accessory Apartment - 1997 UBC			2003
New	Two Story SFR - 1997 UBC	Plan: Amherst IV		2003
New	Approved Basic #02-109726 BP	Plan: 2493	Two Story SFR - 1997 UBC	2003
New	Two Story SFR - 1997 UBC	Plan: 2564		2003
New	Two Story SFR - 1997 UBC			2003
New	Approved Basic #03-106818 BP	Plan: 2896	Two-story SFR - 1997 UBC	2003
New	Two Story SFR - 1997 UBC	Plan: 2830		2003
New	Approved Basic #00-110406 BP	Plan: 2415/pony wall revision	Two Story SFR - 1997 U	2003
New	Approved Basic #03-109236 BP	Plan: 2830	Two Story SFR - 1997 UBC	2003
New	Approved Basic #00-100924 BP	Plan: 2405	Two Story SFR - 1997 UBC	2003
New	Two Story SFR - 1997 UBC	Plan: 2763		2003
New	Approved Basic #03-105820 BP	Plan: 2830	Two Story SFR - 1997 UBC	2003
New	Approved Basic #03-107633BP	Plan: The Orcas	Two Story SFR - 1997 UBC	2003
New	Approved Basic #03-100832 BP	Plan: 2390	Two Story SFR - 1997 UBC	2003
New	Approved Basic #03-109237 BP	Plan: 2581	Two Story SFR - 1997 UBC	2003
New	Approved Basic #03-107666 BP	Plan #2552	Two Story SFR - 1997 UBC	2003
New	Approved Basic #03-105820 BP	Plan: 2830	Two Story SFR - 1997 UBC	2003
New	Approved Basic #03-107662 BP	Plan: 2674	Two Story SFR - 1997 UBC	2003
New	Approved Basic #99-103777BP	Plan: 2415 A/3	Two Story SFR - 1997 UBC	2003
New	Rambler Style SFR - 1997 UBC	Plan: 1827		2003
New	Approved Basic #03-105131 BP	Plan: 2130	Two Story SFR - 1997 UBC	2003
New	Two Story Duplex w/ 1 Car & 2 Car Garage - 1997 UBC			2003
New	Rambler Style SFR -1997 UBC			2003
New	Two Story SFR - 1997 UBC			2003
New	Two Story SFR - 1997 UBC			2003
New	Two Story SFR - 1997 UBC			2003
New	Two Story SFR - 1997 UBC			2003
New	26x56 1987 Glen River 404			2003

Accessory Dwelling Units

Index # - File Name: 1.0022 - Single Family Dwellings Data\_Snohomish County.pdf

New	Approved Basic #03-106298 BP	Plan: So Carolina w/o Den	Two Story SFR - 1997 UB	2003
New	Approved Basic #03-106299 BP	Plan: No Carolina w/o Den	Two Story SFR - 1997 UE	2003
New	Two Story SFR - 1997 UBC			2003
New	Approved Basic #02-110237 BP	Plan: 2311	Two Story SFR - 1997 UBC OPTIO	2003
New	Approved Basic #03-108992 BP	Plan: M 2590 A2F-1	Two-story SFR - 1997 UBC	2003
New	Approved Basic #02-110237 BP	Plan: 2311	Two Story SFR - 1997 UBC OPTIO	2003
New	Approved Basic #03-108995 BP	Plan: 2338	Two Story SFR - 1997 UBC	2003
New	Approved Basic #03-108994 BP	Plan: 2297	Two-story SFR - 1997 UBC	2003
New	Two Story SFR with Attached Garage - 1997 UBC	Plan: 2338		2003
New	Two Story SFR with Attached Garage			2003
New	Approved Basic #02-110237 BP	Plan: 2311	Two Story SFR - 1997 UBC OPTIO	2003
New	Approved Basic #03-106298 BP	Plan: So Carolina w/o Den	Two Story SFR - 1997 UB	2003
New	Approved Basic #03-106300 BP	Plan: 2170 - Hip Louisiana	Two Story SFR - 1997 UBC	2003
New	Approved Basic #03-106298 BP	Plan: So Carolina w/o Den	Two Story SFR - 1997 UB	2003
New	Approved Basic #03-106299 BP	Plan: No Carolina w/o Den	Two Story SFR - 1997 UE	2003
New	Approved Basic #03-101159 BP	Plan: 2127 - side load	Two Story SFR - 1997 UBC	2003
New	Approved Basic #03-101159 BP	Plan: 2127 - side load	Two Story SFR - 1997 UBC	2003
New	Approved Basic #03-101159 BP	Plan: 2127 - side load	Two Story SFR - 1997 UBC	2003
New	Approved Basic #03-106299 BP	Plan: No Carolina w/o Den	Two Story SFR - 1997 UE	2003
New	Approved Basic #03-106297 BP	Plan: 2288-Gable/Georgia	Two Story SFR - 1997 UE	2003
New	Approved Basic #03-106298 BP	Plan: So Carolina w/o Den	Two Story SFR - 1997 UB	2003
New	Approved Basic #03-101155 BP	Plan #2188 side load	Two Story SFR - 1997 UBC	2003
New	Approved Basic #03-101155 BP	Plan #2188 side load	Two Story SFR - 1997 UBC	2003
New	Approved Basic #03-106299 BP	Plan: No Carolina w/o Den	Two Story SFR - 1997 UE	2003
New	Approved Basic #03-106297 BP	Plan: 2288-Gable/Georgia	Two Story SFR - 1997 UE	2003
New	Approved Basic #03-106298 BP	Plan: So Carolina w/o Den	Two Story SFR - 1997 UB	2003
New	Split entry 2 story SFR			2003
New	Two-story SFR			2003
New	SFR Rambler w/garage			2003
New	Daylight Basement Rambler w/51-sf finished/1027-sf unfinished basement & attached Garage.			2003
New	Daylight Basement Rambler w/51-sf finished/1027-sf unfinished basement & attached Garage.			2003
New	Two-story SFR - 1997 UBC			2003
New	Two Story SFR - 1997 UBC			2003
New	Two Story SFR - 1997 UBC			2003
New	Approved Basic #03-105279-BP	Plan: 2535	Two Story SFR - 1997 UBC	2003
New	Two Story SFR - 1997 UBC	Plan 2982		2003
New	Two Story SFR with Attached Garage	Plan: 2760		2003
New	2 Story SFR w/ 3 Car & Covered Porch			2003
New	Approved Basic #02-100274 BP	Plan: 1710	Two Story SFR - 1997 UBC Option	2003
New	Approved Basic #02-109388 BP	Plan: 1575	Tri-Level SFR - 1997 UBC Opt	2003
New	Approved Basic #02-100274 BP	Plan: 1710	Two Story SFR - 1997 UBC Option	2003
New	Two Story SFR - 1997 UBC	Plan: 1758		2003
New	Rambler Style SFR - 1997 UBC			2003
New	Two-story SFR - 1997 UBC			2003
New	Approved Basic 03-109466 BP	Plan: D1703	Two Story SFR - 1997 UBC	2003
New	Approved Basic #03-104418 BP	Plan: 1522	Rambler Style SFR - 1997 UBC	2003
New	Approved Basic #03-104421 BP	Plan: 1447	Rambler Style SFR - 1997 UBC	2003



Accessory Dwelling Units

Index # - File Name: 1.0022 - Single Family Dwellings Data\_Snohomish County.pdf

New	Approved Basic #02-110621 BP	Plan: 1512	Rambler Style SFR - 1997 UBC	2003
New	Approved Basic #03-109934 BP	Plan: 2216	Two Story SFR - 1997 UBC	2003
New	Approved Basic #02-110621 BP	Plan: 1512	Rambler Style SFR - 1997 UBC	2003
New	Rambler Style SFR - 1997 UBC			2003
New	Rambler Style Duplex - 1997 UBC			2003
New	Rambler Style Duplex - 1997 UBC			2003
New	Two Story SFR - 1997 UBC	Plan: 4013	C-L	2003
New	Two Story SFR - 1997 UBC	Plan: 3006	B-C-R	2003
New	Two Story SFR - 1997 UBC	Plan: 5025	B-R	2003
New	2 story SFR w/attached garage	1997 UBC	Plan#4120	2003
New	Two Story SFR - 1997 UBC	Plan: 5252		2003
New	Two Story SFR - 1997 UBC	Plan: 5123		2003
New	2 story SFR w/attached garage	1997 UBC	Plan: The Ashland	2003
New	2 story SFR w/attached garage	1997 UBC	Plan:The Waldron II	2003
New	Two Story SFR - 1997 UBC	Plan: 2790	A 2 S-0	2003
New	Approved Basic #03-109485 BP	Plan: M 2790	A 25-0 Two Story SFR - 1997 UBC	2003
New	Two Story SFR - 1997 UBC	Plan: 4010	DB-B-R	2003
New	Two Story SFR - 1997 UBC	Plan: 5026	B-R	2003
New	Two Story SFR - 1997 UBC	Plan: 5124		2003
New	Approved Basic #03-106445 BP	Plan: 595	A Two Story w/finished basement - 19	2003
New	Approved Basic #03-106445 BP	Plan: 595	A Two Story w/finished basement - 19	2003
New	Approved Basic #03-106445 BP	Plan: 595	A Two Story w/finished basement - 19	2003
New	Two Story SFR - 1997 UBC	Plan: 3011	B-C-LG	2003
New	Two Story SFR - 1997 UBC	Plan: 3010	A-L	2003
New	Two-story SFR - 1997UBC	Plan: Waterford	3302	2003
New	Two-story SFR - 1997UBC	Plan: Oxford		2003
New	Two Story SFR - 1997 UBC	Plan: 5022	F-B-R	2003
New	Two story SFR - 1997 UBC			2003
New	Single story SFR with attached garage			2003
New	Daylight Basement style SFR w/attached garage.			2003
New	Two Story SFR with Attached Garage			2003
New	Two Story SFR - 1997 UBC	Plan #3314		2003
New	Two Story SFR - 1997 UBC	Plan: 2655		2003
New	Two Story SFR - 1997 UBC	Plan #3087/5350		2003
New	Two Story SFR - 1997 UBC			2003
New	Two Story SFR - 1997 UBC			2003
New	Two Story SFR with Attached Garage			2003
New	Two Story SFR with Attached Garage			2003
New	Two Story SFR - 1997 UBC	Plan #3422		2003
New	Two Story SFR - 1997 UBC	Plan: Tyndall	Gable (A)	2003
New	Two-story SFR - 1997UBC	Plan: Madison	Hip (A)	2003
New	Approved Basic #02-109686 BP	Plan: Glacier/Gable (A)	Two Story SFR - 1997 UBC	2003
New	Rambler Style SFR - 1997 UBC	Plan: A-5		2003
New	Approved Basic #02-109015 BP	Plan: 1813	Rambler Style SFR - 1997 UBC	2003
New	Approved Basic #03-108977 BP		Two Story SFR - 1997 UBC	2003
New	Approved Basic #03-108976 BP	Plan: 2268	Rambler Style SFR - 1997 UBC	2003
New	Approved Basic #03-108976 BP	Plan: 2268	Rambler Style SFR - 1997 UBC	2003



Accessory Dwelling Units

Index # - File Name: 1.0022 - Single Family Dwellings Data\_Snohomish County.pdf

New	Approved Basic #03-108977 BP	Two Story SFR - 1997 UBC	2003
New	Approved Basic #03-101981 BP	Plan: 2471 Two-story style SFR.....1997 U	2003
New	Rambler Style SFR - 1997 UBC		2003
New	Approved Basic #03-110578 BP	Plan: 1864 Rambler Style SFR - 1997 UBC	2003
New	New SFR with Basement		2003
New	Two Story SFR - 1997 UBC	Plan: 4	2003
New	Two Story SFR - 1997 UBC	Plan: 5	2003
New	Approved Basic #03-101983 BP	Plan: 1985 SFR w/finished lower floor - 1997	2003
New	Two Story SFR - 1997 UBC	Plan: 1807 B	2003
New	Two Story SFR - 1997 UBC	Plan: 2161	2003
New	Two Story SFR - 1997 UBC	Plan: 2018 A	2003
New	Approved Basic #03-110992 BP	Plan: 2590 A2F-12 Two Story SFR - 1997 UBC	2003
New	Approved Basic #03-110672 BP	Plan: 1784 B2 F-4 Two Story SFR - 1997 UBC	2003
New	Two Story SFR - 1997 UBC	Plan: 2183 A	2003
New	Approved Basic #03-109377 BP	Plan: 2018 A Two Story SFR - 1997 UBC	2003
New	Two Story SFR - 1997 UBC	Plan: 2590 A2F-12	2003
New	Approved Basic #02-106830 BP	Plan #2294 Two Story SFR - 1997 UBC	2003
New	Two Story SFR - 1997 UBC	Plan: 1784 A2 F-4	2003
New	Approved Basic #03-109378 BP	Plan: 2018 B Two Story SFR - 1997 UBC	2003
New	Two Story SFR - 1997 UBC	Plan: 1784 B2 F-4	2003
New	Approved Basic #03-110670 BP	Plan: 2161 Two Story SFR - 1997 UBC	2003
New	Approved Basic #03-108821 BP	Plan: 1228 Gable Rambler Style SFR - 1997 UB	2003
New	Approved Basic #03-108821 BP	Plan: 1228 Gable Rambler Style SFR - 1997 UB	2003
New	One-story SFR with bonus room over garage		2004
New	Two story Log Cabin SFR - 1997 UBC		2004
New	2 Story w/ Semi Finished Bsmt & 2 Car		2004
New	Approved Basic #03-108705 BP	Plan #2009 Two Story SFR - 1997 UBC	2004
New	Approved Basic 04-110348BP	2 story SFR w/attached garage 1997 UBC Plan:2452	2004
New	Approved Basic 04-110351BP	2 story SFR w/attached garage 1997 UBC Plan:2460B	2004
New	Approved Basic 04-110349BP	2 story SFR w/attached garage 1997 UBC Plan:2558.	2004
New	Approved Basic 04-110348BP	2 story SFR w/attached garage 1997 UBC Plan:2452	2004
New	Approved Basic #02-109683 BP	Plan: Shasta/Gable (C) Two Story SFR - 1997 UBC	2004
New	2 Story SFR w/ 3 Car		2004
New	Approved Basic #04-100349 BP	Plan 3314 Two Story SFR - 1997 UBC	2004
New	Approved Basic #03-108826 BP	Plan: 1228 Hip Rambler Style SFR - 1997 UBC	2004
New	Approved Basic 04-110349BP	2 story SFR w/attached garage 1997 UBC Plan:2558.	2004
New	Approved Basic 04-110351BP	2 story SFR w/attached garage 1997 UBC Plan:2460B	2004
New	Approved Basic 04-110356BP, Ref. 04-109878.	2 story SFR w/attached garage 1997 UBC P	2004
New	2 story SFR w/attached garage	1997 UBC Plan :#2452	2004
New	2 story SFR w/attached garage	1997 UBC Plan :#2460A	2004
New	2 story SFR w/attached garage	1997 UBC Plan :#2558A	2004
New	2 story SFRw/attached garage	1997 UBC Plan #2591	2004
New	Approved Basic 04-110353BP	2 story sfr w/attached garage 1997 UBC Plan:2582A Option	2004
New	Approved Basic 04-110345BP	2 story SFR w/attached garage 1997 UBC Plan:2591	2004
New	2 story SFR w/attached garage	2003 IRC Plan:1890	2004
New	2 story SFR w/attached garage	1997 UBC Plan :#2460	2004
New	Approved Basic #01-112969 BP	Plan No. 2321 Mid-entry SFR - 1997 UBC	2004

Accessory Dwelling Units

Index # - File Name: 1.0022 - Single Family Dwellings Data\_Snohomish County.pdf

New	Approved Basic #02-106330 BP	Plan: 1144	Rambler Style SFR - 1997 UBC	2004
New	Two Story SFR - 1997 UBC			2004
New	2-story w/garage			2004
New	Two-story SFR - 1997UBC			2004
New	2-story SFRw/garage			2004
New	Daylight Basement SFR w/attached garage			2004
New	Approved Basic 04-114908BP	Two Story SFR w/attached Garage	1997 UBC Plan: 1908/9	2004
New	Approved Basic #00-100864 BP	Plan: 1601	Two Story SFR - 1997 UBC	2004
New	2-story DUPLEX w garage			2004
New	Two-story SFR - 1997 UBC			2004
New	2-Story SFR w/attached garage.			2004
New	27x56, 2004 Oakwood Grand			2004
New	2 Story SFR w/ 3 Car Garage			2004
New	Approved Basic #04-109195 BP	Plan: Eagle 1	Rambler Style SFR - 1997 UBC	2004
New	Two Story SFR - 1997 UBC	Plan: 2535		2004
New	Approved Basic #03-104321 BP	Plan: 2300 B	Two Story SFR - 1997 UBC	2004
New	Approved Basic #04-109195 BP	Plan: Eagle 1	Rambler Style SFR - 1997 UBC	2004
New	Approved Basic #04-109196 BP	Plan: 2535	Two Story SFR - 1997 UBC	2004
New	Approved Basic 04-113768BP	2 story SFR w/attached garage	2003 IRC Plan:3040	2004
New	Approved Basic #03-104321 BP	Plan: 2300 B	Two Story SFR - 1997 UBC	2004
New	Approved Basic 04-113768BP	2 story SFR w/attached garage	2003 IRC Plan:3040	2004
New	Approved Basic #04-109196 BP	Plan: 2535	Two Story SFR - 1997 UBC	2004
New	Approved Basic #03-104321 BP	Plan: 2300 B	Two Story SFR - 1997 UBC	2004
New	2-Story SFR over unfinished daylight basement w/attached garage.			2004
New	27x68, 2004 Fleetwood			2004
New	Approved Basic #99-115103 BP	Plan: 1452	Rambler Style SFR - 1997 UBC	2004
New	Approved Basic #99-115103 BP	Plan: 1452	Rambler Style SFR - 1997 UBC	2004
New	1 story duplex	2003 IRC		2004
New	Approved Basic #99-115103 BP	Plan: 1452	Rambler Style SFR - 1997 UBC	2004
New	2-Story SFR w/attached garage.			2004
New	SFR w/attached garage	1997 UBC		2004
New	Approved Basic 04-111161BP	Plan: 1932	Two-story SFR - 2003 IRC	2004
New	Approved Basic #02-100273 BP	Plan: 2117	Split Level SFR - 1997 UBC	Opti 2004
New	Approved Basic #03-105143 BP	Plan # J2060	Two Story SFR - 1997 UBC	2004
New	Approved Basic 04-111161BP	Plan: 1932	Two-story SFR - 2003 IRC	2004
New	Approved Basic 04-113137BP	2 story SFR w/attached garage	2003 IRC Plan:2117	2004
New	Approved Basic #03-105143 BP	Plan # J2060	Two Story SFR - 1997 UBC	2004
New	Approved Basic 04-111161BP	Plan: 1932	Two-story SFR - 2003 IRC	2004
New	Approved Basic 04-113137BP	2 story SFR w/attached garage	2003 IRC Plan:2117	2004
New	Approved Basic #03-105143 BP	Plan # J2060	Two Story SFR - 1997 UBC	2004
New	Approved Basic 04-113137BP	2 story SFR w/attached garage	2003 IRC Plan:2117	2004
New	Approved Basic 04-111161BP	Plan: 1932	Two-story SFR - 2003 IRC	2004
New	Approved Basic 04-115323BP	Plan: Cape Cod/BU-04-0133a	Two-story SFR w	2004
New	Two-story SFR - 1997UBC	Plan: Pemberton 2653		2004
New	Two-story SFR - 1997UBC	Plan: Windhaven 4143-03		2004
New	Two-story SFR with finished basement & attached 3-car garage - 2003 IRC			2004
New	Two-story SFR - 1997UBC	Plan: Windhaven 4143-03		2004

Accessory Dwelling Units

Index # - File Name: 1.0022 - Single Family Dwellings Data\_Snohomish County.pdf

New	Approved Basic 04-115323BP	Plan: Cape Cod/BU-04-0133a	Two-story SFR w	2004
New	Approved Basic 04-114954 BP	Plan: Prairie Wind	Two-story SFR - 2003 IRC	2004
New	Two-story SFR - 1997UBC	Plan: Pemberton 2653		2004
New	Approved Basic 04-114954BP	Plan: Prairie Wind	Two-story SFR - 2003 IRC	2004
New	2-story SFR w/garage			2004
New	2-story SFR w/garage			2004
New	Approved Basic 04-113026BP	Builders #2350	2 Story w/ 3 Car	2004
New	Approved Basic 04-114486BP	Plan: 2377	Two-story SFR - 2003 IRC	2004
New	Two Story SFR with Attached Garage	Builders Plan 2591		2004
New	Approved Basic 04-114486BP	Plan: 2377	Two-story SFR - 2003 IRC	2004
New	Approved Basic #04-113156 BP	Plan:2591	2-story w/garage - (2003IRC/IBC)	2004
New	Approved Basic #04-111702 BP	2-story w/garage	2003 IRC Plan:2823	2004
New	2-Story SFR w/attached garage.	1997 UBC		2004
New	Approved Basic #04-111702 BP	2-story w/garage	2003 IRC Plan:2823	2004
New	Approved Basic 04-113028BP	2 story SFR w/ 2 Car	2003 IRC Plan 2539	2004
New	Approved Basic #04-113156 BP	Plan:2591	2-story w/attached garage	2004
New	Approved Basic #04-111702 BP	2-story w/garage	2003 IRC Plan:2823	2004
New	Approved Basic 04- 113026 BP	Builders #2350	2 Story w/ 3 Car	2004
New	Approved Basic 04-116451BP	2 Story SFR w/attached garage	2003 IRC Plan:2415	2004
New	Approved Basic #04-111702 BP	2-story w/garage	2003 IRC Plan:2823	2004
New	2-story SFR w/garage	1997 UBC		2004
New	Two-story SFR - 1997UBC	Plan: M2590C2F-1		2004
New	2 story SFR w/attached garage	1997 UBC	Plan:2822	2004
New	2 story SFR w/attached garage	1997 UBC	Plan :#2885	2004
New	2 story SFR w/attached garage	1997 UBC	Plan:2760	2004
New	2 story SFR w/ attached garage	1997 UBC	Plan:2808	2004
New	Two-story SFR - 1997UBC	Plan 2350		2004
New	Two-story SFR - 1997 UBC	Plan: 2844		2004
New	2 story SFR w/attached garage	1997 UBC	Plan:#2486	2004
New	Two-story SFR - 1997 UBC	Plan: 2844		2004
New	Two-story SFR - 1997UBC			2004
New	2 story SFR w/attached garage	1997 UBC	Plan :#2885	2004
New	2 story SFR w/attached garage	1997 UBC	Plan:2808	2004
New	2 story SFR w/attached garage	1997 UBC	Plan:#2350	2004
New	Two-story SFR - 1997UBC			2004
New	2-Story SFR w/attached Garage.			2004
New	Approved Basic 04-114486BP	Plan: 2377	Two-story SFR - 2003 IRC	2004
New	Approved Basic #04-111702 BP	2-story w/garage	2003 IRC Plan:2823	2004
New	Approved Basic 04-114486BP	Plan: 2377	Two-story SFR - 2003 IRC	2004
New	Approved Basic #04-111702 BP	2-story w/garage	2003 IRC Plan:2823	2004
New	Approved Basic 04-116248 BP	Builder Plan 2823DB	2 story single family wit	2004
New	Two story SFR - 1997 UBC	Plan: #2377		2004
New	Approved Basic #04-111702 BP	2-story w/garage	2003 IRC Plan:2823	2004
New	2-Story SFR w/attached garage.	1997 UBC		2004
New	Two-story SFR - 1997 UBC	Plan: 2493 (Orcas)		2004
New	Approved Basic 04-110562BP	2 story SFR w/attached garage	1997 UBC Plan #2452	2004
New	Approved 04-110564	2 story SFR w/attached garage	1997 UBC Plan:2460	2004

Accessory Dwelling Units

Index # - File Name: 1.0022 - Single Family Dwellings Data\_Snohomish County.pdf

New	Approved Basic #04-111422-BP	Bldr s. Plan 2472	2-Story SFR	1997 UBC	2004
New	Approved Basic 04 111418 BP		Builder s Plan:2400	Two-story SFF	2004
New	Approved Basic #04-111420-BP	Bldr s. Plan 2362	2-Story SFR -	1997 UBC	2004
New	Approved Basic #04-111420-BP	Bldr s. Plan 2362	2-Story SFR -	1997 UBC	2004
New	Approved Basic #04-111421-BP	Bldr s. plan 2424	2-Story SFR -	1997 UBC	2004
New	Approved Basic #04-111422-BP	Bldr s. Plan 2472	2-Story SFR	1997 UBC	2004
New	Two Story SFR -			1997 UBC	2004
New	Approved 04-110564	2 story SFR w/attached garage	1997 UBC	Plan:2460	2004
New	Approved Basic 04-110568BP	2 story SFR w/attached garage	1997 UBC	Plan:249:	2004
New	Approved Basic 04-110562BP	2 story SFR w/attached garage	1997 UBC	Plan #2452	2004
New	2 story SFR w/attached garage	1997 UBC	Plan#:2400-	The Hampton	2004
New	2 story SFR w/attached garage	1997 UBC	Plan#: 2472-	The Amherst II	2004
New	2 story SFR w/attached garage	19997 UBC	Plan#:2424		2004
New	Approved 04-110564	2 story SFR w/attached garage	1997 UBC	Plan:2460	2004
New	Approved Basic 04-110562BP	2 story SFR w/attached garage	1997 UBC	Plan #2452	2004
New	2 story SFRw/attached garage	1997 UBC	Plan: #2362-	The Chateau	2004
New	Approved Basic #03-109380 BP	Plan: 2183 B	Two Story SFR -	1997 UBC	2004
New	Approved Basic #04-109549 BP	Plan: 2196 B	Two Story SFR -	1997 UBC	2004
New	Approved Basic #04-109549 BP	Plan: 2196 B	Two Story SFR -	1997 UBC	2004
New	Approved 04-109995BP	2 story SFRw/attached garage	1997 UBC	Plan:#2460A	2004
New	Approved Basic #04-109576 BP	Plan: 2540 A	Two Story SFR -	1997 UBC	2004
New	Approved Basic 04-109992BP	2 story SFR w/attached garage	1997 UBC	Plan :2	2004
New	Approved Basic 04-109988BP	2 story SFR w/attached garage	1997 UBC	Plan:#2165B	2004
New	Approved Basic #04-109573 BP	Plan: 2196 A	Two Story SFR -	1997 UBC	2004
New	Approved Basic #04-109576 BP	Plan: 2540 A	Two Story SFR -	1997 UBC	2004
New	2-story w/garage				2004
New	2 story single family with 3 car garage				2004
New	Approved Basic #04-109576 BP	Plan: 2540 A	Two Story SFR -	1997 UBC	2004
New	Approved Basic 04-109995BP	2 story SFRw/attached garage	1997 UBC	Plan:#2460A	2004
New	2-story w/attached garage	2003 IRC			2004
New	Two Story SFR -	1997 UBC	Plan: Camden		2004
New	Two-story SFR -	1997 UBC	Plan: Rochester		2004
New	Approved Basic 04-110594BP	SFR w/finished basement & attached garage	1997 UBC	Pla	2004
New	Approved Basic 04-110252BP	2 story SFR w/finished basement	1997 UBC	Plan:1830-Win	2004
New	2 Story SFR w/finished bsmt area & attached garage	1997 UBC	Plan:Newport B-	12345	2004
New	Approved Basic #03-106090 BP	Plan: Nantucket/1142-03	Two-story SFR -	1997 U	2004
New	Approved Basic 04-110249BP	2 story SFR w/finished basement	1997 UBC	Plan:2295-Quinc	2004
New	Approved Basic 04-110252BP	2 story SFR w/finished basement	1997 UBC	Plan:1830-Win	2004
New	Two-story SFR -	1997 UBC	Plan: Quincy		2004
New	Approved Basic 04-110316BP	2 story SFR w/attached garage	1997 UBC	Plan:2182-Rochest	2004
New	Approved Basic 04-110252BP	2 story SFR w/finished basement	1997 UBC	Plan:1830-Win	2004
New	Approved Basic 04-110249BP	2 story SFR w/finished basement	1997 UBC	Plan:2295-Quinc	2004
New	Approved Basic 04-110313BP	2 story SFR w/attached garage	1997 UBC	Plan:2261-Camde	2004
New	Approved Basic 04-110313BP	2 story SFR w/attached garage	1997 UBC	Plan:2261-Camde	2004
New	Approved Basic 04-110249BP	2 story SFR w/finished basement	1997 UBC	Plan:2295-Quinc	2004
New	Approved Basic 04-110316BP	2 story SFR w/attached garage	1997 UBC	Plan :2182-Rc	2004
New	Approved Basic 04-110313BP	2 story SFR w/attached garage	1997 UBC	Plan:2261-Camde	2004

Accessory Dwelling Units

Index # - File Name: 1.0022 - Single Family Dwellings Data\_Snohomish County.pdf

New	Approved Basic 04-110252BP	2 story SFR w/finished basement	1997 UBC	Plan:1830-Win	2004
New	Approved Basic 04-110249BP	2 story SFR w/finished basement	1997 UBC	Plan:2295-Qu	2004
New	Approved Basic 04-110249BP	2 story SFR w/finished basement	1997 UBC	Plan:2295-Quinc	2004
New	SFR w/finsihed basement & attached garage		1997 UBC	Plan:Ashford B-1685	2004
New	Approved Basic 04-110249BP	2 story SFR w/finished basement	1997 UBC	Plan:2295-Quinc	2004
New	SFR w/finished basement -		1997 UBC	Plan: 1685	2004
New	Approved Basic 04-110252BP	2 story SFR w/finished basement	1997 UBC	Plan:1830-Win	2004
New	Approved Basic 04-110313BP	2 story SFR w/attached garage	1997 UBC	Plan:2261-Camde	2004
New	Approved Basic 04-110313BP	2 story SFR w/attached garage	1997 UBC	Plan:2261-Camde	2004
New	Approved Basic 04-110249BP	2 story SFR w/finished basement	1997 UBC	Plan:2295-Quinc	2004
New	Approved Basic 04-110252BP	2 story SFRw/finished basement	1997 UBC	Plan:1830-Winds	2004
New	Approved Basic 04-110316BP	2 story SFR w/attached garage	1997 UBC	Plan:2182-Rochest	2004
New	Two Story SFR w/semi-finished -		1997 UBC	Plan: 2295	2004
New	Two Story SFR -		1997 UBC	Plan: Rochester	2004
New	Tri-Level SFR w/finished lower floor -		1997 UBC	Plan: 2345-A	2004
New	Two Story SFR w/semi-finished basment -		1997 UBC	Plan: 1830	2004
New	Approved Basic 04-110594BP	SFR w/finished basement & attached garage	1997 UBC	Plan	2004
New	Approved Basic 04-110353BP	2 story sfr w/attached garage	1997 UBC	Plan:2582A Option	2004
New	Approved Basic 04-110356BP	2 story SFR w/attached garage	1997 UBC	Plan:2582B Opt	2004
New	Approved Basic 04-110353BP	2 story sfr w/attached garage	1997 UBC	Plan:2582A Option	2004
New	Approved Basic 04-110351BP	2 story SFR w/attached garage	1997 UBC	Plan:2460B	2004
New	Two Story SFR -		1997 UBC	Plan: 2582 A	2004
New	Approved Basic 04-112097BP	2 story SFR w/attached garage	1997 UBC	Plan:2196B	2004
New	Approved Basic #04-108719 BP			Plan: 2460 B Two Story SFR - 1997 UBC	2004
New	Approved Basic 04-110536BP	2 story SFRw/attached garage	1997 UBC	Plan:2446A	2004
New	Two Story SFR -		1997 UBC	Plan: 2300 B	2004
New	Two Story SFR -		1997 UBC	Plan: 2460 A	2004
New	Approved Basic 04-110544BP	2 story SFRw/attached garage	1997 UBC	Plan#2460	2004
New	Approved Basic 04-112097BP	2 story SFR w/attached garage	1997 UBC	Plan:2196B	2004
New	Approved Basic #04-109549 BP			Plan: 2196 B Two Story SFR - 1997 UBC	2004
New	Approved Basic #04-109573 BP			Plan: 2196 A Two Story SFR - 1997 UBC	2004
New	Approved Basic #04-109573 BP			Plan: 2196 A Two Story SFR - 1997 UBC	2004
New	Approved Basic 04-110356BP	2 story SFR w/attached garage	1997 UBC	Plan:2582B	2004
New	Approved Basic 04-110353BP	2 story sfr w/attached garage	1997 UBC	Plan:2582A	2004
New	2 story SFR w/attached garage		1997 UBC	Plan:#2582B	2004
New	2 story SFRw/attached garage		1997 UBC	Plan :#25582A	2004
New	Approved Basic #04-109576 BP			Plan: 2540 A Two Story SFR - 1997 UBC	2004
New	Plan: 2540 B Two Story SFR -			1997 UBC	2004
New	Approved Basic #03-110670 BP			Plan: 2161 Two Story SFR - 1997 UBC	2004
New	Approved Basic #03-110671 BP			Plan: 1784 A2 F-4 Two Story SFR - 1997 UBC	2004
New	Approved Basic #03-109379 BP			Plan: 2183 A Two Story SFR - 1997 UBC	2004
New	Approved Basic #03-110672 BP			Plan: 1784 B2 F-4 Two Story SFR - 1997 UBC	2004
New	Approved Basic #03-110671 BP			Plan: 1784 A2 F-4 Two Story SFR - 1997 UBC	2004
New	Approved Basic #03-109377 BP			Plan: 2018 A Two Story SFR - 1997 UBC	2004
New	Approved Basic #02-106830 BP			Plan #2294 Two Story SFR - 1997 UBC	2004
New	Approved Basic #03-109378 BP			Plan: 2018 B Two Story SFR - 1997 UBC	2004
New	Approved Basic #03-110992 BP			Plan: 2590 A2F-12 Two Story SFR - 1997 UBC	2004

Accessory Dwelling Units

Index # - File Name: 1.0022 - Single Family Dwellings Data\_Snohomish County.pdf

New	Approved Basic #03-109377 BP		Plan: 2018 A	Two Story SFR - 1997 UBC	2004
New	Approved Basic #03-110672 BP		Plan: 1784 B2 F-4	Two Story SFR - 1997 UBC	2004
New	Two Story SFR - 1997 UBC		Plan: 2018 B		2004
New	Two Story SFR - 1997 UBC		Plan: 2183-B		2004
New	Two Story SFR - 1997 UBC		Plan: 1807 -A		2004
New	Approved Basic #02-106830 BP		Plan #2294	Two Story SFR - 1997 UBC	2004
New	Two Story SFR - 1997 UBC		Plan: 2300 A		2004
New	2 story SFR w/attached garage	1997 UBC	Plan:2365A		2004
New	Two-story SFR - 1997 UBC				2004
New	2 story SFR w/attached garage	1997 UBC	Plan:2365B		2004
New	2 story SFR w/attached garage	1997 UBC	Plan #2365C		2004
New	Two-story SFR - 1997UBC				2004
New	Approval Basic 04-113992BP	2 story SFR w/attached garage	1997 UBC	Plan:2110	2004
New	Two Story SFR - 1997 UBC		Plan: 2300 C		2004
New	Approved Basic #04-109549 BP		Plan: 2196 B	Two Story SFR - 1997 UBC	2004
New	Two Story SFR - 1997 UBC		Plan: 2540 B		2004
New	Two story SFR - 1997 UBC		Plan #: 2460-B		2004
New	Two Story SFR - 1997 UBC		Plan: 2590 A		2004
New	Two Story SFR - 1997 UBC		Plan: 2196 B		2004
New	Approved Basic 04-110544BP	2 story SFRw/attached garage	1997 UBC	Plan#2460	2004
New	Approved Basic #04-108717 BP		Plan: 2540 C	Two Story SFR - 1997 UBC	2004
New	Two Story SFR - 1997 UBC		Plan: 2446 A		2004
New	Two Story SFR - 1997 UBC		Plan: 2460 C		2004
New	Approved Basic #04-108744 BP		Plan: 2540 A	Two Story SFR - 1997 UBC	2004
New	Approved Basic #04-108885 BP		Plan: 2196 B	Two Story SFR - 1997 UBC	2004
New	Two-story SFR		Builders Plan: 2165B		2004
New	Approved Basic 04-110542BP	2 story SFR w/attached garage	1997 UBC	Plan :2300A	2004
New	Two Story SFR - 1997 UBC		Plan: 2196 C		2004
New	2 story SFR w/attached garage	1997 UBC	Plan:2136		2004
New	2 story sfr w/attached garage	1997 UBC	Plan:2110		2004
New	Approved Basic #04-109449 BP		Plan: 2446 A	Two Story SFR - 1997 UBC	2004
New	Two-story SFR - 1997 UBC		Plan: 2540 C		2004
New	Approved Basic #04-108719 BP		Plan: 2460 B	Two Story SFR - 1997 UBC	2004
New	Approved Basic #04-109450 BP		Plan: 2460 A	Two Story SFR - 1997 UBC	2004
New	Approved Basic #04-108744 BP		Plan: 2540 A	Two Story SFR - 1997 UBC	2004
New	Approved Basic #04-109456 BP		Plan: 2300 B	Two Story SFR - 1997 UBC	2004
New	2 story SFR w/ attached garage	1997 UBC	Plan:2590A		2004
New	Approved Basic 04-113432BP	2 story SFR w/attached garage	1997 UBC	Plan2540 A	2004
New	Approved Basic 04-110536BP	2 story SFRw/attached garage	1997 UBC	Plan:2446A	2004
New	Approved Basic #04-108744 BP		Plan: 2540 A	Two Story SFR - 1997 UBC	2004
New	Approved Basic #04-109450 BP		Plan: 2460 A	Two Story SFR - 1997 UBC	2004
New	Approved Basic #04-108885 BP		Plan: 2196 B	Two Story SFR - 1997 UBC	2004
New	Approved Basic #04-109449 BP		Plan: 2446 A	Two Story SFR - 1997 UBC	2004
New	2-Story SFR w/attached garage	Builders Plan 2540-A	1997-UBC		2004
New	2 story SFR w/attached garage	1997 UBC	Plan:#2540A		2004
New	Approved Basic 04-109473BP	2 story SFR w/attached garage	1997 UBC	Plan #2165B	2004
New	2 story sfrw/attached garage	1997 UBC	Plan:2590C		2004

Accessory Dwelling Units

Index # - File Name: 1.0022 - Single Family Dwellings Data\_Snohomish County.pdf

New	Approved Basic #04-109455 BP	Plan: 2540 B	Two Story SFR - 1997 UBC	2004
New	Approved Basic 04-110536BP	2 story SFRw/attached garage	1997 UBC Plan:2446A	2004
New	Approved Basic #04-108885 BP	Plan: 2196 B	Two Story SFR - 1997 UBC	2004
New	Approved Basic #04-108719 BP	Plan: 2460 B	Two Story SFR - 1997 UBC	2004
New	Approved Basic #04-109450 BP	Plan: 2460 A	Two Story SFR - 1997 UBC	2004
New	2 story SFR w/attached garage	1997 UBC	Plan:2722	2004
New	2-story w/finished basement & garage	2003 IRC		2004
New	2-story SFR w/attached garage	2003 IRC		2004
New	Two-story SFR - 1997 UBC	Plans: 6420		2004
New	2-story w/garage			2004
New	2 story SFR w/attached garage	1997 UBC	Plan:4224	2004
New	2-story sfr w/garage			2004
New	2-Story SFR w/attached garage.	1997 UBC		2004
New	2 story single family residence			2004
New	Two-story SFR - 1997 UBC	Plan: 4424		2004
New	Two-story SFR - 1997 UBC	Plan: 4422		2004
New	Two-story SFR - 1997 UBC	Plan: 4424		2004
New	2-story SFR w/garage			2004
New	2 story single family residence			2004
New	Approved Basic 04-111694BP	Plan: 4520	Two-story SFR - 1997UBC	2004
New	2 Story SFR w/ 2 Car Garage			2004
New	2 Story SFR w/ 2 Car Garage			2004
New	Two story SFR			2004
New	Two story SFR			2004
New	2 Story w/ 2 Car Garage			2004
New	2 story SFR w/attached garage	1997 UBC	Plan:4224	2004
New	Approved Basic #03-108859 BP	Plan: 2008 A2 S-2	Two Story SFR - 1997 UBC	2004
New	SFR Rambler with attached 3-car garage			2004
New	40 x 66 - 2004 - Golden West - Mobile Home.			2004
New	Two-story SFR - 1997 UBC	Plan: 4224		2004
New	Two-story SFR with attached 2-car garage - 2003 IRC	Plan: 3522		2004
New	Two-story SFR - 1997 UBC	Plan: 4520		2004
New	Two-story SFR - 1997 UBC	Plan: 4422		2004
New	Two-story SFR - 1997 UBC	Plan: 4224		2004
New	2 story single family residence with 3 car garage			2004
New	Two-story SFR - 1997 UBC	Plan 4224		2004
New	Two-story SFR - 1997 UBC	Plan: 4424		2004
New	Two-story SFR - 1997 UBC	Plan: 4424		2004
New	2 story single family residence w/ 2 car garage			2004
New	Approved Basic #03-101982 BP	Plan: 2119	Two Story SFR - 1997 UBC	2004
New	Approved Basic #03-101978 BP	Plan: 2360	Two Story SFR - 1997 UBC	2004
New	1949sf SFR with 1949sf semi-finished daylight basement - 1997UBC			2004
New	Daylight Rambler SFR			2004
New	Approved Basic #04-109156 BP	Plan: 3218	SFR w/finished basement - 1997 UBC	2004
New	Approved Basic #03-108976 BP	Plan: 2268	Rambler Style SFR - 1997	2004
New	Approved Basic #03-108977 BP		Two Story SFR - 1997 UBC	2004
New	Approved Basic #03-108976 BP	Plan: 2268	Rambler Style SFR - 1997 UBC	2004

Accessory Dwelling Units

Index # - File Name: 1.0022 - Single Family Dwellings Data\_Snohomish County.pdf

New	Approved Basic #02-109015 BP	Plan: 1813	Rambler Style SFR - 1997 UBC	(	2004
New	Approved Basic #03-108976 BP	Plan: 2268	Rambler Style SFR - 1997 UBC		2004
New	Approved Basic 04-111879BP	2 story SFR w/attached garage	2003 IRC	Plan:2023	2004
New	Approved Basic 04-111879BP	2 story SFR w/attached garage	2003 IRC	Plan:2023	2004
New	Approved Basic 04-111879BP	2 story SFR w/attached garage	2003 IRC	Plan:2023	2004
New	Approved Basic 04-111872BP	2 story SFR w/attached garage	2003IRC	P	2004
New	Approved Basic 04-111878	Plan: 2370	2 story SFR w/attached garage	2C	2004
New	Approved Basic 04-111878	Plan: 2370	2 story SFR w/attached garage	2C	2004
New	Approved Basic 04-111879BP	2 story SFR w/attached garage	2003 IRC	Plan:2023	2004
New	Approved Basic 04-111879BP	2 story SFR w/attached garage	2003 IRC	Plan:2023	2004
New	Approved Basic 04-111879BP	2 story SFR w/attached garage	2003 IRC	Plan:2023	2004
New	Approved Basic 04-111873BP	2 story SFR w/attached garage	2003 IRC	Plan:2217w/ loft	2004
New	Approved Basic 04-111879BP	2 story SFR w/attached garage	2003 IRC	Plan:2023	2004
New	2 story SFR w/attached garage	2003 IRC	Plan:2023		2004
New	Approved Basic 04-111878	Plan: 2370	2 story SFR w/attached garage	2C	2004
New	Approved Basic 04-111875BP	2 story SFR w/attached garage	2003 IRC	Plan:2217	2004
New	Approved Basic 04-111875BP	2 story SFR w/attached garage	2003 IRC	Plan:2217	2004
New	Approved Basic 04-111879BP	2 story SFR w/attached garage	2003 IRC	Plan:2023	2004
New	Approved Basic 04-111878	Plan: 2370	2 story SFR w/attached garage	2C	2004
New	Approved Basic 04-111879BP	2 story SFR w/attached garage	2003 IRC	Plan:2023	2004
New	Approved Basic 04-111873BP	2 story SFR w/attached garage	2003 IRC	Plan:2217w/ loft	2004
New	Approved Basic 04-111873BP	2 story SFR w/attached garage	1997 UBC	Plan:2217w/ loft	2004
New	Approved Basic 04-111872BP	2 story SFR w/attached garage	1997 UBC		2004
New	Two story SFR - 1997 UBC	Plan # 1544			2004
New	Two Story SFR - 1997 UBC	Plan # 1695			2004
New	Approved Basic 04-111879BP	2 story SFR w/attached garage	1997 UBC	Plan:2023	2004
New	2-Story SFR w/attached garage.				2004
New	2-Story SFR w/attached garage.				2004
New	SFR with Finished Basement - 1997 UBC				2004
New	Two-story SFR				2004
New	Two Story SFR - 1997 UBC	Plan: 3012-B-R			2004
New	Two Story SFR - 1997 UBC	Plan: 3010 A-L			2004
New	Two Story SFR - 1997 UBC	Plan: 3012 C-R			2004
New	Two Story SFR - 1997 UBC	Plan: 3011 B-A-L			2004
New	Two Story SFR - 1997 UBC	Plan: 3010 C-R			2004
New	2 story SFR w/attached garage	1997 UB	Plan:#3012		2004
New	2 story SFR w/attached garage	1997 UBC	Plan:#3010		2004
New	2 story SFR w/attached garage	1997 UBC	Plan:#3011		2004
New	2 story SFR w/attached garage	1997 UBC	Plan :3010		2004
New	Two Story SFR - 1997 UBC	Plan: 3012 B-R			2004
New	2 story SFR w/attached garage	1997 UBC	Plan:3011B		2004
New	2 story SFR w/attached garage	1997 UBC	Plan:3012 A		2004
New	2 story SFR w/attached garage	1997 UBC	Plan:3010 B		2004
New	2 story SFR w/attached garage	1997 UBC	Plan:3012C		2004
New	Two-story SFR - 1997 UBC	Plan: 3111B-B-X			2004
New	2 story SFR w/attached garage	1997 UBC	Plan:3010-A		2004
New	2 story SFR w/attached garage	1997 UBC	Plan:3012B		2004



Accessory Dwelling Units

Index # - File Name: 1.0022 - Single Family Dwellings Data\_Snohomish County.pdf

New	2 story SFR w/attached garage	1997 UBC	Plan:3111B-C	2004
New	Two-story SFR - 1997 UBC		Plan: 3010-C	2004
New	2 story SFR w/attached garage	1997 UBC	Plan:3105-A	2004
New	2 story SFR w/attached garage	1997 UBC	Plan:3--6B-A-X	2004
New	2 story SFR w/attached garage	1997 UBC	Plan:4013B	2004
New	2 story SFR w/attached garage	1997 UBC	Plan:4012B-B	2004
New	2 story SFR w/attached garage	1997 UBC	Plan:5025A	2004
New	2 story SFR w/attached garage	1997 UBC	Plan:3006B-B-X	2004
New	2 Story SFR w/attached garage	1997 UBC	Plan:4013B-C elevation	2004
New	Two-story SFR - 1997 UBC		Plan 3105-C	2004
New	Two-story SFR - 1997UBC		Plan: 4012B-C-L	2004
New	2 Story SFR w/attached garage	1997 UBC	Plan:5025B	2004
New	2 story SFR w/attached garage	1997 UBC	Plan:3006C-X	2004
New	2 Story SFR w/attached garage	1997 UBC	Plan:4010D-C	2004
New	2 story SFR w/attached garage	1997 UBC	Plan:4013-B	2004
New	2 story SFR w/attached garage	1997 UBC	Plan:5025-A	2004
New	2 story SFR w/attached garage	1997 UBC	Plan:4010B-C	2004
New	2 story SFR w/attached garage	1997 UBC	Plan:3105A	2004
New	Two-story SFR - 1997 UBC		Plan 4010 DB-B	2004
New	2 story SFR w/attached garage	1997 UBC	Plan:3105B	2004
New	2 story SFR w/attached garage	1997 UBC	Plan:3006A-X	2004
New	Two-story SFR - 1997 UBC		Plan 4012-C-L	2004
New	2 story SFR w/attached garage	1997 UBC	Plan:3105C	2004
New	2 story SFR w/attached garage	1997 UBC	Plan: 4013B-C elevation	2004
New	2 story SFR w/attached garage	1997 UBC	Plan:3006B	2004
New	2 story SFR w/attached garage	1997 UBC	Plan:4010 DB-C	2004
New	2 story SFR w/attached garage	1997 UBC	Plan:4012B-A	2004
New	2 story SFR w/attached garage	1997 UBC	Plan:4013C	2004
New	2 story SFR w/attached garage	1997 UBC	Plan:3010	2004
New	2 story SFR w/attached garage	1997 UBC	Plan:3012	2004
New	**Structural Plans not issued: Pulled Structural Plans & Destroyed 12/03/07 - jla 2 story SFR w/			2004
New	2 story SFR w/attached garage	1997 UBC	Plan:3012 B	2004
New	2 story Sfr w/attached garage	1997 UBC	Plan:3010 C	2004
New	Two Story SFRw/attached garage	1997 UBC	Plan: 3011 C	2004
New	2 story SFR w/attached garage	1997 UBC	Plan:3012A	2004
New	2 story SFR w/attached garage	1997 UBC	Plan:3111-A	2004
New	2 story SFR w/attached garage	1997 UBC	Plan:3010-B	2004
New	2 story SFR w/attached garage	1997 UBC	Plan:3012-C	2004
New	2 story SFR w/attached garage	1997 UBC	Plan:3010-A	2004
New	Approved Basic #03-110928 BP		Plan: Keystone Two Story SFR - 1997 UBC	2004
New	2 story SFR w/attached garage	1997 UBC	Plan :Keystone	2004
New	Approved Basic #03-110930 BP		Plan: Glendale Two Story SFR - 1997 UBC	2004
New	Two-story SFR		Builder s Plan: Glendale II	2004
New	2 story SFR w/attached garage	1997 UBC	Plan:Glendale	2004
New	Two-story SFR	Plan Check Only (Approved)	Builder s Plan: Decatur	2004
New	Two-story SFR - 1997 UBC		Plan: 2579	2004
New	Two-story SFR	Builders Plan: Possession	2415	2004

Accessory Dwelling Units

Index # - File Name: 1.0022 - Single Family Dwellings Data\_Snohomish County.pdf

New	Approved Basic #04-109641BP	Bldr s. plan #2520	2-Story SFR w/attached garage. - 1997 UBC	2004
New	Two-story SFR - 1997 UBC	Plan #2579		2004
New	Two-story SFR	Builders Plan 2520 (Guemes)		2004
New	Approved Basic #04-109640-BP	Bldr s. Plan #2415	2-Story SFR w/attached garage -	2004
New	Two Story SFR - 1997 UBC	Plan: The Shaw		2004
New	Approved Basic #04-109640-BP	Bldr s. Plan #2415	2-Story SFR w/attached garage -	2004
New	Approved Basic #04-109641BP	Bldr s. plan #2520	2-Story SFR w/attached garage. - 1997 UBC	2004
New	Two-story SFR - 1997UBC	Plan: 2276 San Juan		2004
New	Approved Basic #04-109640-BP	Bldr s. Plan #2415	2-Story SFR w/attached garage -	2004
New	Approved Basic #04-109641BP	Bldr s. plan #2520	2-Story SFR w/attached garage. - 1997 UBC	2004
New	Approved Basic #04-109641BP	Bldr s. plan #2520	2-Story SFR w/attached garage. - 1997 UBC	2004
New	Approved Basic #04-109640-BP	Bldr s. Plan #2415	2-Story SFR w/attached garage -	2004
New	Two Story SFR - 1997 UBC	Plan: The Shaw		2004
New	Approved Basic #04-109640-BP	Bldr s. Plan #2415	2-Story SFR w/attached garage -	2004
New	Approved Basic #04-109641BP	Bldr s. plan #2520	2-Story SFR w/attached garage. - 1997 UBC	2004
New	Two-story SFR	Plan Check Only(Approved)	Builder s Plan: Decatur	2004
New	Approved Basic #03-110650 BP	Plan: Tyndall Gable (A)	Two Story SFR - 1997 UBC	2004
New	Approved Basic #02-110069 BP	Plan: Adams/Gable (D)	Two Story SFR - 1997 UBC	2004
New	Approved Basic #03-110645 BP	Plan: Hazelwood Gable (A)	Two Story SFR - 1997 UBC	2004
New	Approved Basic 04-114592BP	2 story SFR w/attached garage	2003 IRC Plan:Monroe Gable	2004
New	Approved Basic #03-110645 BP	Plan: Hazelwood Gable (A)	Two Story SFR - 1997 UBC	2004
New	Approved Basic #03-110649 BP	Plan: Appleton Gable (A)	Two Story SFR - 1997 UBC	2004
New	Approved Basic #02-110068 BP	Plan: Waterton Gable (A)	Two Story SFR - 1997 UBC	2004
New	Approved Basic #03-110649 BP	Plan: Appleton Gable (A)	Two Story SFR - 1997 UBC	2004
New	Approved Basic #02-109687 BP	Plan: Whitney/Gable (C)	Two Story SFR - 1997 UBC	2004
New	Approved Basic #03-110644 BP	Plan: Langley Hip (A)	Two Story SFR - 1997 UBC	2004
New	Approved Basic #03-110649 BP	Plan: Appleton Gable (A)	Two Story SFR - 1997 UBC	2004
New	Approved Basic #02-109693 BP	Plan: Whitney - Hip (D)	Two Story SFR - 1997 UBC	2004
New	Approved Basic #02-109683 BP	Plan: Shasta/Gable (C)	Two Story SFR - 1997 UBC	2004
New	Approved Basic #03-104903 BP	Plan: Granite Hip (A)	Two Story SFR - 1997 UBC	2004
New	Approved Basic #02-109683 BP	Plan: Shasta/Gable (C)	Two Story SFR - 1997 UBC	2004
New	Approved Basic #03-110650 BP	Plan: Tyndall Gable (A)	Two Story SFR - 1997 UBC	2004
New	Approved Basic #02-109067 BP	Plan: Siskiyou/Gable - Side	Two Story SFR - 1997 UBC	2004
New	Approved Basic #02-109693 BP	Plan: Whitney - Hip (D)	Two Story SFR - 1997 UBC	2004
New	Approved Basic #02-109690 BP	Plan: Olympic/Gable (D)	Two Story SFR - 1997 UBC	2004
New	Approved Basic #02-109687 BP	Plan: Whitney/Gable (C)	Two Story SFR - 1997 UBC	2004
New	Approved Basic #03-110644 BP	Plan: Langley Hip (A)	Two Story SFR - 1997 UBC	2004
New	Approved Basic #03-104903 BP	Plan: Granite Hip (A)	Two Story SFR - 1997 UBC	2004
New	Approved Basic #02-110070 BP	Plan: Trinity/Gable (D)	Two Story SFR - 1997 UBC	2004
New	Approved Basic #02-109690 BP	Plan: Olympic/Gable (D)	Two Story SFR - 1997 UBC	2004
New	Approved Basic #02-109693 BP	Plan: Whitney - Hip (D)	Two Story SFR - 1997 UBC	2004
New	Approved Basic #02-109690 BP	Plan: Olympic/Gable (D)	Two Story SFR - 1997 UBC	2004
New	Approved Basic #03-110644 BP	Plan: Langley Hip (A)	Two Story SFR - 1997 UBC	2004
New	Approved Basic #02-109694 BP	Plan: Stewart/Gable (D)	SFR w/finished lower floor	2004
New	Approved Basic #03-110649 BP	Plan: Appleton Gable (A)	Two Story SFR - 1997 UBC	2004
New	Approved Basic #02-110068 BP	Plan: Waterton Gable (A)	Two Story SFR - 1997 UBC	2004
New	Approved Basic #03-110647 BP	Plan: Teton Hip (B)	Two Story SFR - 1997 UBC	2004

Accessory Dwelling Units

Index # - File Name: 1.0022 - Single Family Dwellings Data\_Snohomish County.pdf

New	Approved Basic #03-110645 BP	Plan: Hazelwood Gable (A)	Two Story SFR - 1997	2004
New	Approved Basic #02-109683 BP	Plan: Shasta/Gable (C)	Two Story SFR - 1997 UBC	2004
New	Approved Basic #02-109690 BP	Plan: Olympic/Gable (D)	Two Story SFR - 1997 UBC	2004
New	Approved Basic #02-110069 BP	Plan: Adams/Gable (D)	Two Story SFR - 1997 UBC	2004
New	Approved Basic #03-110645 BP	Plan: Hazelwood Gable (A)	Two Story SFR - 1997	2004
New	Approved Basic 04-117864BP	Plan: G523-B	Two-story SFR with attached	2004
New	Approved Basic 04-117562BP	Plan: G522-A	Two-story SFR with attached	2004
New	Approved Basic 04-108983BP	Plan: G 523 A	Two Story SFR - 1997 UBC	2004
New	Approved Basic #04-109187 BP	Plan: G 522 C	Two Story SFR - 1997 UBC	2004
New	Two Story SFR - 1997 UBC	Plan: G.523-B		2004
New	Two Story SFR - 1997 UBC	Plan: G.522-A		2004
New	Approved Basic #02-109686 BP	Plan: Glacier/Gable (A)	Two Story SFR - 1997 UBC	2004
New	Approved Basic #03-110650 BP	Plan: Tyndall Gable (A)	Two Story SFR - 1997 UBC	2004
New	Approved Basic 04-110187BP	2 story SFR w/attached garage	1997 UBC	Plan:Appalachian 2004
New	Approved Basic #02-109683 BP	Plan: Shasta/Gable (C)	Two Story SFR - 1997 UBC	2004
New	Approved 04-113274BP	Two Story SFR with Attached Garage	1997 UBC	Plan :306 2004
New	26 -8 x 44 - 2004 - Marlette, 9599-3 - Mobile Home.			2004
New	2 Story SFR with attached garage	50PSF maximum designed snow load.		2004
New	SFR with unfinished basement. Rough-in only for future duplex unit in basement.			2004
New	Revised drained. SFR with unfinished basement. Rough-in only for future duplex unit in base			2004
New	Approved Basic #04-108981 BP	Plan: G 524 C	Two Story SFR - 1997 UBC	2004
New	Daylight basement style SFR w/attached garage.			2004
New	Rambler with 2nd story Bonus Room			2004
New	27x 42 Marlette First Edition			2004
New	Approved Basic 04-116880BP	Plan: G524-C	Two-story SFR with attached	2004
New	Two-story SFR - 1997 UBC	Plan: G.524-C		2004
New	Two Story SFR - 1997 UBC	Plan: B-125-A		2004
New	Approved Basic #04-108980 BP	Plan: G 524 A	Two Story SFR - 1997 UBC	2004
New	Approved Basic #04-109183 BP	Plan: B 125 B	Two Story SFR - 1997 UBC	2004
New	Approved Basic 04-116881BP	Plan: G524-C	Two-story SFR with attached	2004
New	Approved Basic 04-116879BP	Plan: G524-A	Two-story SFR with attached	2004
New	Approved Basic 04-117864BP	Plan: G523-B	Two-story SFR with attached	2004
New	Approved Basic 04-119040BP	Plan: 5350	Two-story SFR with attach	2004
New	Approved Basic 04-119040BP	Plan: 5350	Two-story SFR with attach	2004
New	Rambler Style SFR - 1997 UBC	3 bedroom design		2004
New	Two-story SFR with attached garage - 2003 IRC			2004
New	Approved Basic #04-100349 BP	Plan 3314	Two Story SFR - 1997 UBC	2004
New	2-story SFR w/garage	1197 UBC		2004
New	Approved Basic #04-100347 BP	Plan 3087/5350	Two Story SFR - 1997 UBC	2004
New	Approved Basic #04-100347 BP	Plan 3087/5350	Two Story SFR - 1997 UBC	2004
New	Approved Basic #04-100347 BP	Plan 3087/5350	Two Story SFR - 1997 UBC	2004
New	Approved Basic #04-100347 BP	Plan 3087/5350	Two Story SFR - 1997 UBC	2004
New	Approved Basic 04-113274BP	Two Story SFR w/ Attached Garage	1997 UBC	Plan: 2004
New	Two-story SFR - 1997 UBC			2004
New	2 Story w/ 3 Car - 2003 IRC			2004
New	2 Story w/ 3 Car - 2003 IRC			2004
New	Two-story SFR with attached garage - 2003 IRC			2004

Accessory Dwelling Units

Index # - File Name: 1.0022 - Single Family Dwellings Data\_Snohomish County.pdf

New	Approved Basic #04-100347 BP	Plan 3087/5350	Two Story SFR - 1997 UBC	2004
New	Approved Basic #02-100274 BP	Plan: 1710	Two Story SFR - 1997 UBC Option	2004
New	Approved Basic 04-117593BP	2 story SFR w/attached garage	2003 IRC Plan:1529	2004
New	Approved Basic 04-113137BP	2 story SFR w/attached garage	2003 IRC Plan:2117	2004
New	2-Story SFR w/attached garage.			2004
New	1525sf Rambler - 1997UBC			2004
New	One story SFR w/attached garage			2004
New	2 Story Single Family Residence			2004
New	Rambler style SFR - 1997UBC			2004
New	Two-story SFR - 1997 UBC			2004
New	Approved Basic #03-100446 BP	Plan: 2838	Two Story SFR - 1997 UBC	2004
New	Two-story SFR	Builder s Plan: 2415		2004
New	Approved Basic #04-111702 BP	2-story w/garage	2003 IRC Plan:2823	2004
New	Approved Basic 04-114486BP	Plan: 2377	Two-story SFR - 2003 IRC	2004
New	2 story single family w/attached garage	- 2003 IRC		2004
New	2-Story SFR w/attached garage.			2004
New	Approved Basic 04-114495BP	Plan: 2328	Two-story SFR - 2003 IRC	2004
New	Two-story SFR - 1997 UBC	Builders Plan: 2743		2004
New	Two-story SFRw/attached garage - 1997UBC			2004
New	813 Sq Ft SFR Above 960 Sq Ft Garage			2004
New	Approved Basic 04 111326 BP	-Structure must be built in 29 or more hght allowed zone	3 st	2004
New	Two-story SFR			2004
New	Two-story SFR w/unfinished basement			2004
New	2-Story SFR w/attached garage.			2004
New	26 -8 x 60 - 2004 - Silvercrest Mobile Home.			2004
New	2-story w/garage			2004
New	SFR Rambler w/garage			2004
New	Approved Basic 04-119217BP	2 story SFR w/attached garage	2003 IRC Plan:1931A	2004
New	Approved Basic 04-119219BP	2 story SFR w/attached garage	2003 IRC Plan:2475B	2004
New	Approved Basic 04-116860BP	2 stroy SFR w/attached garage	2003 IRC Plan:1931B	2004
New	Approved Basic 04-117433BP	2 story SFR w/attached garage	2003 IRC Plan:1921A	2004
New	Approved Basic 04-117960BP	Plan Number 2251	2 story with 2 car garage - 2003 IRC	2004
New	Approved Basic 04-117253BP	2 story SFR w/attached garage	2003 IRC Plan:2485A	2004
New	Approved Basic 04-116860BP	2 stroy SFR w/attached garage	2003 IRC Plan:1931B	2004
New	Approved Basic 04-119217BP	2 story SFR w/attached garage	2003 IRC Plan:1931A	2004
New	Approved Basic 04-117258BP	2 story SFR w/attached garage	2003 IRC Plan:1951C	2004
New	Approved Basic 04-116858BP	2 story SFR w/attached garage	2003 IRC Plan1951B	2004
New	Approved Basic 04-116513BP	Plan: 2421 A & B	Two-story SFR with atta	2004
New	Approved Basic 04-116493BP	Plan: 2421 C	Two-story SFR with attached	2004
New	Approved Basic #03-106909 BP	Plan: 1821 B	Two Story SFR - 1997 UBC	2004
New	Approved Basic #03-105251 BP	Plan: 1611 A	Two Story SFR - 1997 UBC	2004
New	Approved Basic 04-116503BP	Plan: 1811B	Two-story SFR with attached	2004
New	Two Story SFR - 1997 UBC	Plan: 2831 (Elev. C)		2004
New	Approved Basic 04- 115883BP	Builders Plan #2431C	2 Story w/ 2 Car Garage	2004
New	Approved Basic 04-116517BP	Plan: 2221 B	Two-story SFR with attached gara	2004
New	Approved Basic #03-105252 BP	Plan: 1611 (Elev C)	Two Story SFR - 1997 UBC	2004
New	Two Story SFR - 1997 UBC	Plan: 2021 (Elev B)		2004

Accessory Dwelling Units

Index # - File Name: 1.0022 - Single Family Dwellings Data\_Snohomish County.pdf

New	Two Story SFR - 1997 UBC	Plan: 2211 (Elev A)		2004
New	Two Story SFR - 1997 UBC	Plan: 2111 Elev. (A)		2004
New	Two Story SFR - 1997 UBC	Plan: 2841 (Elev B)		2004
New	Two Story SFR - 1997 UBC	Plan: 2295 B		2004
New	Approved Basic #04-100112 BP	Plan: 2011 C	Two Story SFR - 1997 UBC	2004
New	Approved Basic #03-105913 BP	Plan: 2585 (Elev A)	Two Story SFR - 1997 UBC	2004
New	Approved Basic #03-106908 BP	Plan: 1821 (Elev A)	Two Story SFR - 1997 UBC	2004
New	Approved Basic 04-116509BP	Plan: 1821B	Two-story SFR with attached	2004
New	Approved Basic 04-116853BP	2 Stroy SFR w/attached garage	2003 IRC Plan:2721B	2004
New	Approved Basic #04-100103 BP	Plan: 2021 C	Two Story SFR - 1997 UBC	2004
New	Approved Basic 04-116509BP	Plan: 1821B	Two-story SFR with attached	2004
New	Approved Basic 04-117244BP	2 story SFR w/attached garage	2003 IRC Plan:2141A	2004
New	2 story single family residence	1997 UBC		2004
New	Rambler style SFR w/garage			2004
New	Approved Basic 04-116860BP	2 stroy SFR w/attached garage	2003 IRC Plan:1931B	2004
New	Approved Basic 04-118607BP	2 Story SFR w/attached garage	2003 IRC Plan:2261B	2004
New	Approved Basic 04-116860BP	2 stroy SFR w/attached garage	2003 IRC Plan:1931B	2004
New	Approved Basic 04-116858BP	2 story SFR w/attached garage	2003 IRC Plan:1951B	2004
New	Approved Basic 04-117219BP	2 story SFR w/attached garage	2003 IRC Plan:1931C	2004
New	Approved Basic 04-119214BP	2 story SFR w/attached garage	2003 IRC Plan:2831 A & C	2004
New	Approved Basic 04-118605BP	2 story SFR w/attached garage	2003 IRC Plan:1731A	2004
New	Approved Basic 04-111190BP	2 story SFR w/attached garage	1997 UBC Plan :2777	2004
New	Approved Basic 04-111188BP	2 story SFR w/attached garage	1997 UBC Plan #2775A	2004
New	Two Story SFR - 1997 UBC	Plan: 2540 B		2004
New	Approved Basic 04-111189BP	2 story SFR w/ attached garage	1997 UBC Plan:2775B	2004
New	Approved Basic 04-111188BP	2 story SFR w/attached garage	1997 UBC Plan #2775A	2004
New	Approved Basic 04-111187BP	2 story SFR w/attached garage	1997 UBC Plan:2540B	2004
New	Approved Basic 04-111190BP	2 story SFR w/attached garage	1997 UBC Plan :2777	2004
New	Two Story SFR - 1997 UBC	Plan: 2775 B		2004
New	Approved Basic 04-111191BP	2 story SFR w/attached garage	1997 UBC Plan:2883A	2004
New	Two Story SFR - 1997 UBC	Plan: 2777 A		2004
New	Approved Basic 04-111189BP	2 story SFR w/ attached garage	1997 UBC Plan:2775B	2004
New	Two Story SFR - 1997 UBC	Plan: 2883 B		2004
New	Approved Basic 04-111192BP	2 story SFR w/attached garage	1997 UBC Plan:3060A	2004
New	Two Story SFR - 1997 UBC	Plan: 3060 B		2004
New	Approved Basic 04-111194BP	2 story SFR w/attached garage	1997 UBC Plan #3060B	2004
New	Two-story SFR with attached	2-car garage - 2003 IRC		2004
New	Approved Basic #03-110681 BP	Plan: 1706	Two Story SFR - 1997 UBC	2004
New	Approved Basic #02-110377 BP	Plan 2006	Two Story SFR-1997 UBC - Option	2004
New	Approved Basic #02-103159 BP	Plan: 2180 SSI	Two Story SFR....1997 UBC	2004
New	Approved Basic #02-103157 BP	Plan No. 2108 SSI	Two Story SFRw attached garage-	2004
New	Approved Basic #02-103159 BP	Plan: 2180 SSI	Two Story SFR....1997 UBC	2004
New	Approved Basic #02-110377 BP	Plan 2006	Two Story SFR - 1997 UBC	2004
New	Approved Basic #02-103159 BP	Plan: 2180 SSI	Two Story SFR....1997 UBC	2004
New	Approved Basic #02-103157 BP	Plan No. 2108 SSI	Two Story SFRw attached garage-	2004
New	Approved Basic #02-110377 BP	Plan 2006	Two Story SFR - 1997 UBC	2004
New	Approved Basic #02-103159 BP	Plan: 2180 SSI	Two Story SFR....1997 UBC	2004

Accessory Dwelling Units

Index # - File Name: 1.0022 - Single Family Dwellings Data\_Snohomish County.pdf

New	Approved Basic #03-110681 BP		Plan: 1706 Two Story SFR - 1997 UBC	2004
New	Approved Basic #02-103159 BP		Plan: 2180 SSI Two Story SFR....1997 UBC	2004
New	Approved Basic #02-103157 BP		Plan No. 2108 SSI Two Story SFRw attached garage-	2004
New	Approved Basic #02-110377 BP	Plan 2006	Two Story SFR - 1997 UBC Option #1: TC	2004
New	Approved Basic #02-103159 BP		Plan: 2180 SSI Two Story SFR....1997 UBC	2004
New	Approved Basic #02-110377 BP		Plan 2006 Two Story SFR - 1997 UBC	2004
New	Approved Basic #04-112448 BP		Plan: 2180 2-story w/garage - (2003 IRC/IBC)	2004
New	Approved Basic #02-103159 BP		Plan: 2180 SSI Two Story SFR....1997 UBC	2004
New	Approved Basic #02-110377BP	Plan 2006	Two Story SFR - 1997 UBC Option #1: 1	2004
New	Approved Basic #02-110377 BP		Plan 2006 Two Story SFR - 1997 UBC	2004
New	Approved Basic #02-103159 BP		Plan: 2180 SSI Two Story SFR....1997 UBC	2004
New	Approved Basic #02-110377 BP		Plan 2006 Two Story SFR - 1997 UBC	2004
New	Approved Basic #02-103158 BP		Plan: 2342 SSI Two Story SFR....1997 UBC	2004
New	Approved Basic #02-103159 BP		Plan: 2180 SSI Two Story SFR....1997 UBC	2004
New	Approved Basic #02-110377 BP		Plan 2006 Two Story SFR - 1997 UBC	2004
New	Approved Basic #02-103159 BP		Plan: 2180 SSI Two Story SFR....1997 UBC	2004
New	Approved Basic #02-103157 BP		Plan No. 2108 SSI Two Story SFRw attached garage-	2004
New	Approved Basic #02-103157 BP		Plan No. 2108 SSI Two Story SFRw attached garage-	2004
New	Approved Basic #02-110377 BP		Plan 2006 Two Story SFR - 1997 UBC	2004
New	Approved Basic #04-112452 BP		Plan: 2736 2-story w/garage (2003 IRC/IBC)	2004
New	Approved Basic #02-103159 BP		Plan: 2180 SSI Two Story SFR....1997 UBC	2004
New	Approved Basic #02-103157 BP		Plan No. 2108 SSI Two Story SFRw attached garage-	2004
New	Approved Basic #02-103158 BP		Plan: 2342 SSI Two Story SFR....1997 UBC	2004
New	Approved Basic #02-110377 BP		Plan 2006 Two Story SFR - 1997 UBC	2004
New	Approved Basic #02-110377 BP	Plan 2006	Two Story SFR - 1997 UBC Option #1: TGI fl	2004
New	Approved Basic #02-103157 BP		Plan No. 2108 SSI Two Story SFRw attached garage-	2004
New	Approved Basic #02-110377 BP		Plan 2006 Two Story SFR - 1997 UBC	2004
New	Approved Basic #02-103159 BP		Plan: 2180 SSI Two Story SFR....1997 UBC	2004
New	Approved Basic #02-110377 BP		Plan 2006 Two Story SFR - 1997 UBC	2004
New	Approved Basic #02-110377 BP		Plan 2006 Two Story SFR - 1997 UBC	2004
New	Approved Basic #03-110681 BP		Plan: 1706 Two Story SFR - 1997 UBC	2004
New	Approved Basic #02-103159 BP		Plan: 2180 SSI Two Story SFR....1997 UBC	2004
New	2 story SFR w/attached garage	2003 IRC	Plan:2575	2004
New	Approved Basic #02-103159 BP		Plan: 2180 SSI Two Story SFR....1997 UBC	2004
New	Approved Basic #02-110377 BP		Plan 2006 Two Story SFR - 1997 UBC	2004
New	Approved Basic #02-103159 BP		Plan: 2180 SSI Two Story SFR....1997 UBC	2004
New	Approved Basic #02-110377 BP		Plan 2006 Two Story SFR - 1997 UBC	2004
New	2 story SFR w/attached garage	2003 IRC	Plan 2461	2004
New	Approved Basic #02-110005 BP		Plan 1784 Rambler-style SFR - 1997 UBC C	2004
New	Approved Basic #02-110377 BP		Plan 2006 Two Story SFR - 1997 UBC	2004
New	Approved Basic #02-110005 BP		Plan 1784 Rambler-style SFR - 1997 UBC C	2004
New	Approved Basic #02-103157 BP		Plan No. 2108 SSI Two Story SFRw attached garage-	2004
New	Approved Basic #02-110377 BP		Plan 2006 Two Story SFR - 1997 UBC	2004
New	Approved Basic #03-110550 BP		Plan: 1172 - ORO Two Story SFR - 1997 UBC	2004
New	Approved Basic #04-100230-BP		Plan 1174 ORO- flat lot Two Story SFR - 1997 UBC	2004
New	Two Story SFR - 1997 UBC		Plan: 1177-ORO-N	2004
New	Approved Basic 04-113594BP		This structure must be built in a 32 or more height zone 2 stor	2004

Accessory Dwelling Units

Index # - File Name: 1.0022 - Single Family Dwellings Data\_Snohomish County.pdf

New	Approved Basic 04-113546BP	Structure must be built in 34 height or more zone	2 story	2004
New	Approved Basic #04-109306 BP	Plan: 1177 ORO-N	Two Story SFR - 1997 UBC	2004
New	Approved Basic #04-109306 BP	Plan: 1177 ORO-N	Two Story SFR - 1997 UBC	2004
New	Approved Basic #03-110553 BP	Plan: 1175	Two Story SFR - 1997 UBC	2004
New	Approved Basic #04-109306 BP	Plan: 1177 ORO-N	Two Story SFR - 1997 UBC	2004
New	Approved Basic #04-109306 BP	Plan: 1177 ORO-N	Two Story SFR - 1997 UBC	2004
New	Approved Basic #03-110544 BP	Plan: 1176 ORO (FB)	Two Story SFR w/finished basen	2004
New	Approved Basic #03-110544 BP	Plan: 1176 ORO (FB)	Two Story SFR w/finished basen	2004
New	Approved Basic #03-110549 BP	Plan: 1174 ORO (B)	Two Story SFR w/finished baser	2004
New	One-story SFR over basement garage/rec room			2004
New	2-Story SFR w/attached garage.			2004
New	Tri-level SFR - 1997UBC			2004
New	Two-story SFR - 1997UBC			2004
New	Approved Basic #03-104650 BP	Plan: Amber	Two-story SFR - 1997 UBC	2004
New	Approved Basic #01-103742 BP	Plan: Patrick	Rambler Style SFR - 1997 UBC	2004
New	Approved Basic #03-104643 BP	Plan: Bartlett	Two-story SFR - 1997 UBC	2004
New	Approved Basic #03-104637 BP	Plan: Albany	Two-story SFR - 1997 UBC	2004
New	Approved Basic #01-103740 BP	Plan: Aspen	Rambler Style SFR - 1997 UBC	2004
New	Approved Basic #01-103742 BP	Plan: Patrick	Rambler Style SFR - 1997 UBC	2004
New	Approved Basic #03-104637 BP	Plan: Albany	Two-story SFR - 1997 UBC	2004
New	Approved Basic #01-103742 BP	Plan: Patrick	Rambler Style SFR - 1997 UBC	2004
New	Approved Basic #03-104643 BP	Plan: Bartlett	Two-story SFR - 1997 UBC	2004
New	Two Story Duplex with attached 2-car garage		1997 UBC	2004
New	Two story duplex w/ attached garage		1997 UBC	2004
New	One Story SFR		1997 UBC	2004
New	Approved Basic #03-110544 BP	Plan: 1176 ORO (FB)	Two Story SFR w/finished basen	2004
New	Two Story SFR w/finished basement - 1997 UBC	Plan: 1176 ORO		2004
New	Approved Basic #03-110549 BP	Plan: 1174 ORO (B)	Two Story SFR w/finished baser	2004
New	Approved Basic #03-110544 BP	Plan: 1176 ORO (FB)	Two Story SFR w/finished basen	2004
New	Approved Basic #03-110549 BP	Plan: 1174 ORO (B)	Two Story SFR w/finished baser	2004
New	Approved Basic #03-110544 BP	Plan: 1176 ORO (FB)	Two Story SFR w/finished basen	2004
New	Approved Basic #04-109306 BP	Plan: 1177 ORO-N	Two Story SFR - 1997 UBC	2004
New	Approved Basic #03-110553 BP	Plan: 1175	Two Story SFR - 1997 UBC	2004
New	Approved Basic #04-109306 BP	Plan: 1177 ORO-N	Two Story SFR - 1997 UBC	2004
New	Approved Basic #03-110553 BP	Plan: 1175	Two Story SFR - 1997 UBC	2004
New	Approved Basic #04-109306 BP	Plan: 1177 ORO-N	Two Story SFR - 1997 UBC	2004
New	Approved Basic #04-109306 BP	Plan: 1177 ORO-N	Two Story SFR - 1997 UBC	2004
New	2-story SFR over garage - 1997 UBC	11/30/07	Plan job copy destroyed. Permit issued. shuggins	2004
New	Approved Basic #03-110544 BP	Plan: 1176 ORO (FB)	Two Story SFR w/finished basen	2004
New	Approved Basic #03-110549 BP	Plan: 1174 ORO (B)	Two Story SFR w/finished baser	2004
New	Approved Basic #03-110544 BP	Plan: 1176 ORO (FB)	Two Story SFR w/finished basen	2004
New	Approved Basic #03-110544 BP	Plan: 1176 ORO (FB)	Two Story SFR w/finished basen	2004
New	Approved Basic #03-110549 BP	Plan: 1174 ORO (B)	Two Story SFR w/finished baser	2004
New	Approved Basic #03-110544 BP	Plan: 1176 ORO (FB)	Two Story SFR w/finished basen	2004
New	Approved Basic 04-118667BP	2 story SFR w/attached garage	2003 IRC Plan:1172 ORO	2004
New	Approved Basic 04-113593BP	Plan: 1760 Flat	Two-story SFR - 2003 IRC	2004
New	Approved Basic 04-113570BP	Plan 1174	Two-story SFR 2003 IRC	2004

Accessory Dwelling Units

Index # - File Name: 1.0022 - Single Family Dwellings Data\_Snohomish County.pdf

New	Approved Basic 04-113593BP	Plan: 1760 Flat Two-story SFR - 2003 IRC	2004
New	Approved Basic 04-113750BP	Two-story SFRw/attached garage	2004
New	Approved Basic 04-118667BP	2 story SFR w/attached garage 2003 IRC Plan:1172 ORO	2004
New	2-story SFR w/attached garage	2003 IRC	2004
New	2-Story Duplex w/attached double garages.		2004
New	Approved Basic #03-110550 BP	Plan: 1172 - ORO Two Story SFR - 1997 UBC	2004
New	Approved Basic #04-100229 BP	Plan 1176 ORO Two Story SFR - 1997 UBC	2004
New	Two-story SFR w/unfinished basement		2004
New	Two Story SFR - 1997 UBC	Plan: 2475 (Elev C)	2004
New	One-story SFR - 1997 UBC	Builder s Plan: 2225	2004
New	Approved Basic #03-104592 BP	Plan 2003 Rambler Style SFR - 1997UBC	2004
New	Approved Basic #04-100230-BP	Plan 1174 ORO- flat lot Two Story SFR - 1997 UBC	2004
New	Approved Basic #04-100229 BP	Plan 1176 ORO Two Story SFR - 1997 UBC	2004
New	Approved Basic #03-110550 BP	Plan: 1172 - ORO Two Story SFR - 1997 UBC	2004
New	Approved Basic #04-100229 BP	Plan 1176 ORO Two Story SFR - 1997 UBC	2004
New	Approved Basic #03-110550 BP	Plan: 1172 - ORO Two Story SFR - 1997 UBC	2004
New	Approved Basic #04-100229 BP	Plan 1176 ORO Two Story SFR - 1997 UBC	2004
New	Approved Basic #03-110550 BP	Plan: 1172 - ORO Two Story SFR - 1997 UBC	2004
New	Approved Basic #04-100230-BP	Plan 1174 ORO- flat lot Two Story SFR - 1997 UBC	2004
New	Approved Basic #04-100229 BP	Plan 1176 ORO Two Story SFR - 1997 UBC	2004
New	Approved Basic 04-114621 BP	Builder s Plan: 1677 Two-story SFR	2004
New	Two-story SFR- 1997 UBC		2004
New	2-story SFR w/garage		2004
New	Two Story Duplex with Attached Garages	2003 IRC	2004
New	Two Story SFR - 1997 UBC	Plan: B 125 B	2004
New	Pending Basic #04-112893 BP	Plan: B 125 A Two Story SFR - 1997 UBC	2004
New	Approved Basic 04-112101BP	Plan: B-128-A Two-story SFR - 1997UBC	2004
New	Approved Basic 04-112105BP	Plan: B-127-A Two-story SFR - 1997UBC	2004
New	Approved Basic 04-112891BP	Plan: B 125 B Two-story SFR - 1997UBC	2004
New	Approved Basic 04-118540BP	Plan: B-128-B Two-story SFR with attac	2004
New	Approved Basic 04-113549BP	Plan: B 127 C Two-story SFR - 1997 UBC	2004
New	Approved Basic 04-112891BP	Plan: B 125 B Two-story SFR - 1997UBC	2004
New	Approved Basic #04-113156 BP	Plan:2591 2-story w/attached garage	2 2004
New	Approved Basic 04-113026BP	Builders #2350 2 Story w/ 3 Car	2 2004
New	Approved Basic #04-113156 BP	Plan:2591 2-story w/attached garage	2 2004
New	Approved Basic 04-114486BP	Plan: 2377 Two-story SFR - 2003IRC	2004
New	Approved Basic #04-113156 BP	Plan:2591 2-story w/attached garage	2 2004
New	Two story SFR - 1997 UBC	Plan: #2311	2004
New	Two-story SFR - 1997UBC		2004
New	Approved Basic 04-114486BP	Plan: 2377 Two-story SFR - 2003IRC	2004
New	Approved Basic 04-115715BP	Plan: 2949 Two-story SFR - 2003 IRC	2004
New	Approved Basic 04-115715BP	Plan: 2949 Two-story SFR - 2003 IRC	2004
New	Approved Basic 04-116008BP	2 story SFR w/attached garage 2003 IRC Plan:2160	2004
New	Approved Basic 04-116008BP	2 story SFR w/attached garage 2003 IRC Plan:2160	2004
New	Approved Basic 04-116008BP	2 story SFR w/attached garage 2003 IRC Plan:2160	2004
New	Approved Basic 04-1125956BP	2 story SFR w/attached garage 2003 IRC Plan:2054	2004
New	Approved Basic 04-115715BP	Plan: 2949 Two-story SFR - 2003 IRC	2004



Accessory Dwelling Units

Index # - File Name: 1.0022 - Single Family Dwellings Data\_Snohomish County.pdf

New	Approved Basic #04-108826 BP	Plan: 2949 R-3 Two Story SFR - 1997 UBC	2004
New	Approved Basic #04-108831 BP	Plan: 3232 R-3 Two Story SFR - 1997 UBC	2004
New	Approved Basic #04-108782 BP	Plan: 1856 R-2 Rambler Style SFR - 1997 UBC	2004
New	Approved Basic 04-115715BP	Plan: 2949 Two-story SFR - 2003 IRC	2004
New	Approved Basic 04-116007BP	2 story SFR w/attached garage 2003 IRC Plan:2242	2004
New	Approved Basic 04-116007BP	2 story SFR w/attached garage 2003 IRC Plan:2242	2004
New	Approved Basic 04-115710BP	Plan: 2677 Two-story SFR - 2003 IRC	2004
New	Approved Basic 04-116008BP	2 story SFR w/attached garage 2003 IRC Plan:2160	2004
New	Approved Basic 04-116008BP	2 story SFR w/attached garage 2003 IRC Plan:2160	2004
New	Approved Basic #04-108823 BP	Plan: 2469 R-3 Two-story SFR - 1997UBC	2004
New	Approved Basic 04-114570BP	2 story SFR w/attached garage 1997 UBC Plan:3052R1	2004
New	Approved Basic #04-108818 BP	Plan: 2677 R-1 Two Story SFR - 1997 UBC	2004
New	Approved Basic #04-108829 BP	Plan: 3232 R-1 Two Story SFR - 1997 UBC	2004
New	Approved Basic #04-108770 BP	Plan: 1211 R-1 Rambler Style SFR - 1997 UI	2004
New	Approved Basic #04-108824 BP	Plan: 2949 R-1 Two Story SFR - 1997 UBC	2004
New	Approved Basic 04-116008BP	2 story SFR w/attached garage 2003 IRC Plan:2160	2004
New	Approved Basic #04-108826 BP	Plan: 2949 R-3 Two Story SFR - 1997 UBC	2004
New	Approved Basic 04-115715BP	Plan: 2949 Two-story SFR - 2003 IRC	2004
New	Approved Basic 04-114123BP	Plan: 3232B R1, R2, R4 Two-story SFR - 199	2004
New	Approved Basic 04-115724BP	Plan: 2949B Two-story SFR with daylight	2004
New	Approved Basic 04-113707BP	Bldr s. Plan 2677B 2-Story w/finished basement	2004
New	One-story SFR w/finished basement - 1997 UBC		2004
New	Rambler with attached garage		2004
New	Approved Basic 04-112155BP	2 story Duplex w/attached garage 1997 UBC Plan:1549x2	2004
New	2274sf Rambler - 1997 UBC		2004
New	Two-story SFR - 1997 UBC		2004
New	Two Story SFR - 1997 UBC	Plan: M2241C3F-2	2004
New	Approved Basic #04-111334 BP	Bldrs plan #M2535A3F-O 2-story w/garage -	2004
New	Two Story SFR with Attached Garage	Plan: M2605A3S-0	2004
New	Approved Basic 04-111343 BP	Bldrs #M2870A3F-O 2-story w/garage	2004
New	Approved Basic 04 111448 BP	Builder s plan: 2-3000-3 Two-story S	2004
New	Approved Basic #04-114316-BP	Bldrs. Plan #2-3079-3 2-Story SFR	2004
New	Approved Basic #04-111334 BP	Bldrs plan #M2535A3F-O 2-story w/garage -	2004
New	Approved Basic 04 111448 BP	Builder s plan: 2-3000-3 Two-story S	2004
New	Approved Basic #04-111341 BP	Bldrs plan #2755 2-story w/garage.....1997 l	2004
New	Approved Basic 03-108093 BP	Bldrs #M2870A3F-O 2-story w/garage	2004
New	Approved Basic 04 -111448 BP	Builder s plan: 2-3000-3 Two-story	2004
New	Approved Basic 04-115153BP	Plan: M2605A3S-O 2-story w/garage - 1997 UBC	2004
New	Approved Basic 03-111343 BP	Bldrs #M2870A3F-O 2-story w/garage	2004
New	Approved Basic #04-111341 BP	Bldrs plan #2755 2-story w/garage.....1997 l	2004
New	Approved Basic #04-111339 BP	Plan #M2625A3F-O 2-story w/garage -	2004
New	Approved Basic #04-113133 BP	Bldrs plan #M2535A3F-O 2-story w/garage -	2004
New	Approved Basic #04-111341 BP	Bldrs plan #2755 2-story w/garage.....1997 l	2004
New	Approved Basic #04-111448-BP	Bldrs. Plan #2-3000-3 2-Story SFR	2004
New	Approved Basic 04 111450 BP	Builder s plan: 2580 A & B Two-story SFR -	2004
New	Approved Basic 04 114316 BP	Builder s plan: 2-3079-3 Two-story SFR - 20	2004
New	Approved Basic #04-111339 BP	Plan #M2625A3F-O 2-story w/garage -	2004

Accessory Dwelling Units

Index # - File Name: 1.0022 - Single Family Dwellings Data\_Snohomish County.pdf

New	Approved Basic 04-120560BP	Plan: M2415A3F-4	Two-story SFR with att:	2004
New	Rambler with 254 square foot bonus room above garage			2004
New	2-story SFR			2004
New	2 Story w/ 4 car garages & covered porch			2004
New	1 Bedroom Accessory Apt			2004
New	Approved Basic 04-116008BP	2 story SFR w/attached garage	2003 IRC Plan:2160	2004
New	Approved Basic 04-116008BP	2 story SFR w/attached garage	2003 IRC Plan:2160	2004
New	Approved Basic 04-115724BP	Plan: 2949B	Two-story SFR with daylight	2004
New	Approved Basic 04-116007BP	2 story SFR w/attached garage	2003 IRC Plan:2242	2004
New	Mid Entry SFR			2004
New	Mid Entry SFR			2004
New	2869sf rambler - 1997 UBC			2004
New	Approved Basic 04-118540BP	Plan: B-128-B	Two-story SFR with attac	2004
New	Approved Basic 04-118698BP	2 story SFR w/attached garage	2003 IRC Plan:B127A	2004
New	Approved Basic 04 -119331 BP		Two-story SFRw/attached garage	2004
New	Approved Basic 04 -119331 BP		Two-story SFRw/attached garage	2004
New	Approved Basic #04-108819 BP	Plan: 2677 R-2	Two Story SFR - 1997 UBC	2004
New	1386 one-story SFR with 1296sf garage - 1997 UBC			2004
New	Two story SFR with attached 2-car garage	1997 UBC	Plan1565A	2004
New	Two story SFR with attached 2 car garage	1997 UBC	Plan:1368A	2004
New	Approved Basic 04-113488 BP		2 story SFRw/attached garage - 1	2004
New	Approved Basic 04 113494 BP		2 story SFRw/attached garage 1	2004
New	Approved Basic 04 113488 BP		Two-story SFRw/attached garage	2004
New	Approved Basic 04-113494 BP		Two-story SFRw/attached garag	2004
New	Approved Basic 04-112103BP	2 story SFR w/attached garage	2003 IRC Plan:Glacier Peak	2004
New	Approved Basic 04-112107BP	2 story SFR w/attached car	2003 IRC Plar	2004
New	Approved Basic 04-112107BP	2 story SFR w/attached car	2003 IRC Plar	2004
New	Approved Basic 04-112108-BP	Rambler w/attached garage	2003-IRC	2004
New	Approved Basic 04-112756BP	2 story SFR w/attached garage	2003 IRC Plan:Mt Rainier B	2004
New	Approved Basic #112108-BP	Ramblerw/attached garage	2003-IRC E	2004
New	Approved Basic 04-112102-BP	Mid-Entry w/finished basement	2003-IRC	2004
New	Approved Basic #02-109499 BP	Plan: 1344	Split Level SFR - 1997 UBC	2004
New	Approved Basic 04-112103BP	2 story SFR w/attached garage	2003 IRC Plan:Glacier Peak	2004
New	Approved Basic 04-1120161 BP	Plan: Mt. Index	2 story sfr w/attached 3-ca	2004
New	Approved Basic 04-112103BP	2 story SFR w/attached garage	2003 IRC Plan:Glacier Peak	2004
New	Approved Basic 04-112756BP	2 story SFR w/attached garage	2003 IRC Plan: Mt Rainier	2004
New	Approved Basic 04-112103BP	2 story SFR w/attached garage	2003 IRC Plan:Glacier Peak	2004
New	Approved Basic #04-112108-BP	Rambler w/attached garage	2003-IRC	2004
New	Approved Basic 04-112107BP	2 story SFR w/attached car	2003 IRC Pla	2004
New	Approved Basic 04-112103BP	2 story SFR w/attached garage	2003 IRC Plan:Glacier Pea	2004
New	Approved Basic 04-112108-BP	Rambler w/attached garage	2003-IRC	2004
New	Approved Basic 04-112756BP	2 story SFR w/attached garage	2003 IRC Plan: Mt Rainier	2004
New	Approved Basic 04-112103BP	2 story SFR w/attached garage	2003 IRC Plan:Glacier Peak	2004
New	Rambler w/ 2 Car and second floor storage .			2004
New	Approved Basic 04 -112228 BP		Two Story SFR w/attached garag	2004
New	Approved Basic 04-112229 BP		Two Story SFR w/attached garage- 199	2004
New	Approved Basic 04-113791BP	Plan: 1943	Two-story SFR - 2003 IRC	2004

Accessory Dwelling Units

Index # - File Name: 1.0022 - Single Family Dwellings Data\_Snohomish County.pdf

New	Approved	04-114575BP	2 story SFR w/attached garage	2003 IRC	Plan:2215	2004
New	Approved	Basic 04 112226 BP			Two Story SFRw/attached garage	2004
New	Approved	Basic 04 -112228 BP			Two Story SFR w/attached garag	2004
New	Approved	04-114575BP	2 story SFR w/attached garage	2003 IRC	Plan:2215	2004
New	Approved	Basic 04-112229 BP			Two Story SFR w/attached garage- 199	2004
New	Approved	04-114575BP	2 story SFR w/attached garage	2003 IRC	Plan:2215	2004
New	Approved	Basic 04 -112228 BP			Two Story SFR w/attached garag	2004
New	Approved	Basic #04-118535 BP	2-story w/garage	2003 IRC	Plan: E	2004
New	Approved	Basic #03-105121 BP		Plan: B2a	Two-story SFR - 1997 UBC	2004
New	Approved	Basic #03-105123 BP		Plan: B3a	Two-story SFR - 1997 UBC	2004
New	Approved	Basic #03-105119 BP		Plan: B1b	Two-story SFR - 1997 UBC	2004
New	Approved	Basic #03-105121 BP		Plan: B2a	Two-story SFR - 1997 UBC	2004
New	Approved	Basic #03-105123 BP		Plan: B3a	Two-story SFR - 1997 UBC	2004
New	Approved	Basic #03-105119 BP		Plan: B1b	Two-story SFR - 1997 UBC	2004
New	Approved	Basic #03-105123 BP		Plan: B3a	Two-story SFR - 1997 UBC	2004
New	Approved	Basic #03-105123 BP		Plan: B3a	Two-story SFR - 1997 UBC	2004
New	Approved	Basic #03-105121 BP		Plan: B2a	Two-story SFR - 1997 UBC	2004
New	Approved	Basic #03-105119 BP		Plan: B1b	Two-story SFR - 1997 UBC	2004
New	Approved	Basic #03-105123 BP		Plan: B3a	Two-story SFR - 1997 UBC	2004
New	Approved	Basic #03-105123 BP		Plan: B3a	Two-story SFR - 1997 UBC	2004
New	Approved	Basic #03-105121 BP		Plan: B2a	Two-story SFR - 1997 UBC	2004
New	Approved	Basic #03-105123 BP		Plan: B3a	Two-story SFR - 1997 UBC	2004
New	Approved	Basic #04-118535 BP	2-story w/garage	2003 IRC	Plan: E	2004
New	Approved	Basic 03-102960 BP		Plan: D1a	Two-story SFR - 1997UBC	2004
New	Approved	Basic 04-112229 BP			Two Story SFR w/attached garage- 199	2004
New	Approved	Basic 04-112229BP	2 story SFR w/attached garage	1997 UBC	Plan:2204	2004
New	Approved	04-114575BP	2 story SFR w/attached garage	2003 IRC	Plan:2215	2004
New	Approved	Basic 04-11302BP		Plan: 2132A	Two-story SFR - 2003 IRC	2004
New	approved	Basic 04-113791BP		Plan: 1943	Two-story SFR - 2003 IRC	2004
New	Approved	Basic 04 -112228 BP			Two Story SFR w/attached garag	2004
New	Approved	Basic #03-105122 BP		Plan: A1a	Two-story SFR - 1997 UBC	2004
New	Approved	Basic #03-105122 BP		Plan: A1a	Two-story SFR - 1997 UBC	2004
New	Approved	Basic 03-102959BP		Plan A2a	Two-story SFR - 1997 UBC	2004
New	Approved	Basic #03-105122 BP		Plan: A1a	Two-story SFR - 1997 UBC	2004
New	Approved	Basic #03-105119 BP		Plan: B1b	Two-story SFR - 1997 UBC	2004
New	Approved	Basic 03-102960 BP		Plan: D1a	Two-story SFR - 1997UBC	2004
New	Approved	Basic 04-113801BP		Plan 2143	Two-story SFR - 2003 IRC	2004
New	Approved	Basic 04-113791BP		Plan: 1943	Two-story SFR - 2003 IRC	2004
New	Approved	basic 04-114575BP	2 story SFR w/attached garage	2003 IRC	Plan:2215	2004
New	Approved	Basic 04-11302BP		Plan: 2132A	Two-story SFR - 2003 IRC	2004
New	Approved	Basic 04-113791BP		Plan: 1943	Two-story SFR - 2003 IRC	2004
New	Approved	Basic 04-113801BP		Plan 2143	Two-story SFR - 2003 IRC	2004
New	Approved	Basic 04-112229 BP			Two Story SFR w/attached garage- 199	2004
New	Approved	Basic 04 -112228 BP			Two Story SFR w/attached garag	2004
New	Approved	Basic 04-112226 BP			Two Story SFRw/attached garage	2004
New	Approved	Basic 04-113801BP		Plan 2143	Two-story SFR - 2003 IRC	2004
New	Approved	Basic #03-105123 BP		Plan: B3a	Two-story SFR - 1997 UBC	2004

Accessory Dwelling Units

Index # - File Name: 1.0022 - Single Family Dwellings Data\_Snohomish County.pdf

New	Approved Basic 04 112226 BP		Two Story SFRw/attached garage	2004
New	Approved Basic 04 -112228 BP		Two Story SFR w/attached garag	2004
New	Approved Basic 04-113791BP	Plan: 1943	Two-story SFR - 2003 IRC	2004
New	Approved basic 04-114575BP	2 story SFR w/attached garage	2003 IRC Plan:2215	2004
New	Approved Basic #03-105123 BP		Plan: B3a Two-story SFR - 1997 UBC	2004
New	Approved Basic #05-116442BP	2003 IRC	Plan:C-GN 2 story SFR w/attached garage	2004
New	Approved Basic #03-105121 BP		Plan: B2a Two-story SFR - 1997 UBC	2004
New	Approved Basic #03-105121 BP		Plan: B2a Two-story SFR - 1997 UBC	2004
New	Approved Basic #05-116442BP	2003 IRC	Plan: C-GN 2 story SFR w/attached garage	2004
New	Approved Basic #03-105123 BP		Plan: B3a Two-story SFR - 1997 UBC	2004
New	Approved Basic 03-102960 BP		Plan: D1a Two-story SFR - 1997UBC	2004
New	Rambler style SFR w/attached garage	1997 UBC	Plan: Clear Creek	2004
New	Approved Basic #02-109811 BP	Plan: 1576	Rambler Style SFR - 1997 UBC	2004
New	Approved Basic 04-113407BP	2 story SFR w/attached garage	1997 UBC Plan:Appleton	2004
New	Approved Basic #02-109809 BP		Plan: Jessica II Rambler Style SFR - 1997 UBC	2004
New	Approved Basic #03-110428-BP	1997 UBC	Plan: Madison Rambler style SFR - 19	2004
New	Approved Basic #02-109811 BP	Plan: 1576	Rambler Style SFR - 1997 UBC	2004
New	Approved Basic #03-110428-BP	1997 UBC	Plan: Madison Rambler style SFR - 19	2004
New	Approved Basic #02-109811 BP	Plan: 1576	Rambler Style SFR - 1997 UBC	2004
New	Single family residence - Rambler -		1997 UBC	2004
New	Approved Basic # 03-101040 BP	Plan: Katie	Two Story SFR - 1997 UBC	2004
New	Approved Basic #03-104791 BP	Plan: Getchell	Rambler Style SFR - 1997 UBC	2004
New	Approved Basic 04-113472-BP	Bldr s. Plan 2197	Rambler Style SFR - 2003-IR	2004
New	Approved Basic #01-113747 BP	Plan: 2024	Two Story SFR - 1997 UBC	2004
New	Approved Basic #03-104791 BP	Plan: Getchell	Rambler Style SFR - 1997 UBC	2004
New	Approved Basic #01-113747 BP	Plan: 2024	Two Story SFR - 1997 UBC	2004
New	SFR Rambler w/attached garage -		1997UBC	2004
New	Rambler w/ Daylight basement & 2 Car Garage			2004
New	Two-story SFR with 651sf unfinished basement -		2003 IRC	2004
New	1861 sq ft SFR with 1861 sq ft Semi-finished Basement			2004
New	Rambler style SFR w/attached garage	1997 UBC	Plan: Richland	2004
New	Approved Basic # 03-101040 BP	Plan: Katie	Two Story SFR - 1997 UBC	2004
New	Rambler style SFR w/attached garage	1997 UBC	Plan:Eaglecrest	2004
New	2 story SFR w/attached garage	1997 UBC	Plan: Appleton	2004
New	Approved Basic # 03-101040 BP	Plan: Katie	Two Story SFR - 1997 UBC	2004
New	Rambler style SFR w/attached garage	1997 UBC	Plan: Ridgeview	2004
New	Approved Basic #02-109811 BP	Plan: 1576	Rambler Style SFR - 1997 UBC	2004
New	Approved Basic #02-109809 BP	Plan: Jessica II	Rambler Style SFR - 1997 UBC	2004
New	Approved Basic #02-109811 BP	Plan: 1576	Rambler Style SFR - 1997 UBC	2004
New	2 Story SFRw/attached garage	1997 UBC	Plan #3011	2004
New	Two Story SFR - 1997 UBC	Plan: 4111 C-LG		2004
New	Rambler style SFR w/attached garage.			2004
New	Rambler style SFR w/attached garage			2004
New	Approved Basic #00-107111 BP		Rambler style SFR.....1997 UBC	2004
New	2861 square foot rambler			2004
New	Rambler style SFR w/attached garage.			2004
New	Two-story SFR - 1997 UBC	Plan: Magnolia		2004

Accessory Dwelling Units

Index # - File Name: 1.0022 - Single Family Dwellings Data\_Snohomish County.pdf

New	2-story w/garage			2004
New	Two Story SFR - 1997 UBC	Plan: 4111 C-L		2004
New	2 Story SFR w/attached garage	1997 UBC	Plan #4008	2004
New	2 story SFR w/attached garage	1997 UBC	Plan #5022	2004
New	Two Story SFR - 1997 UBC	Plan: 4010 DB-A		2004
New	2 story SFR w/attached garage	1997 UBC	Plan:5022F-B	2004
New	2 story SFR w/attached garage	1997 UBC	Plan :4111B	2004
New	2 story SFR w/attached garage	1997 UBC	Plan:4010/4410	2004
New	2 story SFR w/attached garage	1997 UBC	Plan:4008C	2004
New	Two Story SFR w/attached garage	1997 UBC	Plan: 5022 F-C	2004
New	2 story SFR w/attached garage	1997 UBC	Plan:4010 B elevation	2004
New	2 story SFR w/attached garage	1997 UBC	Plan:4111	2004
New	2 story SFR w/attached garage	1997 UBC	Plan:4008/4408	2004
New	2 story SFR w/attached garage	1997 UBC	Plan:4010/4410	2004
New	2 story SFR w/attached garage	1997 UBC	Plan #4111	2004
New	2 story SFR w/attached garage	1997 UBC	Plan:4008/4408	2004
New	2 story SFR w/attached garage	1997 UBC	Plan#5X22	2004
New	2 Story SFR w/attached garage	1997 UBC	Plan #5022-opt BF,F	2004
New	2 Story SFR w/attached garage	1997 UBC	Plans #4008	2004
New	2 story SFR w/attached garage	1997 UBC	Plan :#5X22	2004
New	Two Story SFR - 1997 UBC	Plan: 4111 C-LGD		2004
New	Two Story SFR - 1997 UBC	Plan: 4010 D-C-RD		2004
New	Two Story SFR - 1997 UBC	Plan: 4008 B-L		2004
New	Two Story SFR - 1997 UBC	Plan: 5022 FB-B-L		2004
New	2 story SFR w/attached garage	1997 UBC	Plan:#4111	2004
New	2 story SFR w/attached garage	1997 UBC	Plan: #4008/4408	2004
New	2 story SFR w/attached garage	1997 UBC	Plan #5022	2004
New	2 story sfr w/attached garage	1997 UBC	Plan #4010-Opt. DB	2004
New	Two Story SFR - 1997 UBC	Plan: 4008 A-RX		2004
New	2-story SFR w/garage			2004
New	Approved Basic 04-111710 BP		Builder s Plan: Sierra 3-Car Two-story SFR	2004
New	Two-story SFR w/attached garage.		Builder s Plan: Richmond	2004
New	2-story w/garage	1997 UBC		2004
New	Approved Basic #04-100240 BP	Plan: Magnolia, 2-car	Two Story SFR - 1997 UBC	2004
New	Two-story SFR - 1997UBC	Crawford Plan		2004
New	Two-story SFR - 1997UBC	Plan: Prescott B		2004
New	Quad-level style SFR including/attached garage.			2004
New	2 story SFR w/attached garage	1997 UBC		2004
New	Two Story SFR - 1997 UBC	Plan: 5025 B-L		2004
New	2 Story w/ Finished Basement and 3 Car Garage			2004
New	Two story SFR with attached garage			2004
New	Two-story SFR - 1997 UBC			2004
New	Two Story SFR - 1997 UBC	Plan: 5554		2004
New	2 story single family residence			2004
New	Rambler style SFR w/garage			2004
New	Rambler style SFR w/attached garage.			2004
New	2 story SFR w/attached garage	1997 UBC	Plan:#2009	2004

Accessory Dwelling Units

Index # - File Name: 1.0022 - Single Family Dwellings Data\_Snohomish County.pdf

New	Two Story SFR - 1997 UBC	Plan: 4013 B-A-R	2004
New	Two Story SFR - 1997 UBC	Plan: 3105-C-L	2004
New	Two Story SFR - 1997 UBC	Plan: 3006 B-A-L	2004
New	Two Story SFR - 1997 UBC	Plan: 4013 B-C-L	2004
New	Two Story SFR - 1997 UBC	Plan: 4012 B-A-R	2004
New	Two Story SFR - 1997 UBC	Plan: 5025 L-C-L	2004
New	Two Story SFR - 1997 UBC	Plan: 3006 B-B-LX	2004
New	Two Story SFR - 1997 UBC	Plan: 4013 B-B-R	2004
New	Two Story SFR - 1997 UBC	Plan: 3105 C-L	2004
New	Two Story SFR - 1997 UBC	Plan: 4012 B-A-R	2004
New	27 x 54 - 2004 - Marlette Mobile home.		2004
New	Two Story SFR - 1997 UBC	Plan: 3010 C-R	2004
New	Two Story SFR - 1997 UBC	Plan: 3011 C-L	2004
New	Approved Basic #04-108936 BP	Plan #2577 Two Story SFR - 1997 UBC	2004
New	2 Story SFR with attached garage		2004
New	Two Story SFR - 1997 UBC		2004
New	Two Story SFR - 1997 UBC		2004
New	1525sf Rambler - 1997UBC		2004
New	Approved Basic 04-116503BP	Plan: 1811B Two-story SFR with attached	2004
New	Approved Basic 04-11744BP	2 story SFR w/attached garage 2003 IRC Plan:1821A	2004
New	Approved Basic 04-117012BP	2 story SFR w/attached garage 2003 IRC Plan:2111A	2004
New	Approved Basic 04-117442BP	2 story SFR w/attached garage 2003 IRC Plan:1611C	2004
New	Approved Basic 04-116509BP	Plan: 1821B Two-story SFR with attached	2004
New	Approved Basic 04-117246BP	2 story SFR w/attached garage 2003 IRC Plan:2221A	2004
New	Approved Basic 04-117251BP	2 story SFR w/attached garage 2003 IRC Plan :1621A	2004
New	Approved Basic 04-116515BP	Plan: 2031A Two-story SFR with attached gara	2004
New	Approved Basic 04-116493BP	Plan: 2421C Two-story SFR with attached	2004
New	Approved Basic 04-116513BP	Plan: 2421 A & B Two-story SRR with atta	2004
New	Approved Basic 04-117263BP	2 story SFR w/attached garage 2003 IRC Plan:3131B	2004
New	Approved Basic 04-119551BP	2 story SFR w/attached garage 2003 IRC Plan:3541B	2004
New	Approved Basic 04-117263BP	2 story SFR w/attached garage 2003 IRC Plan:3131B	2004
New	Approved Basic 04-116513BP	Plan: 2421 A & B Two-story SFR with atta	2004
New	Approved Basic 04-116493BP	Plan: 2421 C Two-story SFR with attached	2004
New	Approved Basic 04-120594BP	2 story SFR w/attached garage 2003 IRC Plan:2011A	2004
New	Approved Basic 04-117012BP	2 story SFR w/attached garage 2003 IRC Plan:2111A	2004
New	Approved Basic 04-119795BP	2 story SFR w/attached garage 2003 IRC Plan:1821C	2004
New	Approved Basic 04-116509BP	Plan: 1821B Two-story SFR with attached	2004
New	Approved Basic 04-11744BP	2 story SFR w/attached garage 2003 IRC Plan:1821A	2004
New	Approved Basic 04-117244BP	2 story SFR w/attached garage 2003 IRC Plan:2141A	2004
New	Approved Basic 04-117244BP	2 story SFR w/attached garage 2003 IRC Plan:2141A	2004
New	Approved Basic 04-120464BP	2 story SFR w/attached garage 2003 IRC Plan:2565B	2004
New	Approved Basic 04-116509BP	Plan: 1821B Two-story SFR with attached	2004
New	Approved Basic 04-120107BP	2 story SFR w/attached garage 2003 IRC Plan:3121C	2004
New	Approved Basic 04-116513BP	Plan: 2421 A & B Two-story SFR with atta	2004
New	Approved Basic 04-116493BP	Plan: 2421 C Two-story SFR with attached	2004
New	Approved Basic #04-109596 BP	Plan: 2611 A Two Story SFR - 1997 UBC	2004
New	Approved Basic #03-104827 BP	Plan: 2421 (Elev. C) Two Story SFR - 1997 UBC	2004

Accessory Dwelling Units

Index # - File Name: 1.0022 - Single Family Dwellings Data\_Snohomish County.pdf

New	Two Story SFR - 1997 UBC	Plan: 2611 A	2004
New	Approved Basic #04-109606 BP	Plan: 2611 C Two Story SFR - 1997 UBC	2004
New	Two Story SFR - 1997 UBC	Plan: 2031 (Elev B)	2004
New	Approved Basic #03-104831 BP	Plan: 2811 (Elev. C) Two Story SFR - 1997 UBC	2004
New	Approved Basic #03-104826 BP	Plan: 2421 (Elev. B) Two Story SFR - 1997 UBC	2004
New	Two Story SFR - 1997 UBC	Plan: 2421 (Elev. A)	2004
New	Two Story SFR - 1997 UBC	Plan: 2531 C	2004
New	Approved Basic #03-106396 BP	Plan: 1821 (Elev A) Two Story SFR - 1997 UBC	2004
New	Approved Basic #03-105913 BP	Plan: 2585 (Elev A) Two Story SFR - 1997 UBC	2004
New	Two Story SFR - 1997 UBC	Plan: 1821 Elev. (B)	2004
New	Approved Basic #03-104827 BP	Plan: 2421 (Elev. C) Two Story SFR - 1997 UBC	2004
New	Approved Basic #03-106400 BP	Plan: 1841 (Elev A) Two Story SFR - 1997 UBC	2004
New	Approved Basic #03-105251 BP	Plan: 1611 A Two Story SFR - 1997 UBC	2004
New	Approved Basic #03-104826 BP	Plan: 2421 (Elev. B) Two Story SFR - 1997 UBC	2004
New	Approved Basic #03-106908 BP	Plan: 1821 (Elev A) Two Story SFR - 1997 UBC	2004
New	Two Story SFR - 1997 UBC	Plan: 2811 (Elev. C)	2004
New	Two Story SFR - 1997 UBC	Plan: 2411 (Elev. C)	2004
New	Approved Basic #03-106909 BP	Plan: 1821 B Two Story SFR - 1997 UBC	2004
New	Approved Basic #03-106910 BP	Plan: 1821 (Elev C) Two Story SFR - 1997 UBC	2004
New	Two Story SFR - 1997 UBC	Plan: 1631 (Elev A)	2004
New	Approved Basic #03-106910 BP	Plan: 1821 (Elev C) Two Story SFR - 1997 UBC	2004
New	Two Story SFR - 1997 UBC	Plan: 2021 A	2004
New	Approved Basic #03-106910 BP	Plan: 1821 (Elev C) Two Story SFR - 1997 UBC	2004
New	Two Story SFR - 1997 UBC	Plan: 2131(A)	2004
New	Two Story SFR - 1997 UBC	Plan: 1611 A	2004
New	Two Story SFR - 1997 UBC	Plan: 1511 C	2004
New	Approved Basic #03-105252 BP	Plan: 1611 C Two Story SFR - 1997 UBC	2004
New	Two Story SFR - 1997 UBC	Plan: 2141 Elev. (C)	2004
New	Two Story SFR - 1997 UBC	Plan: 2011 (Elev C)	2004
New	Approved Basic #03-105251 BP	Plan: 1611 A Two Story SFR - 1997 UBC	2004
New	Two Story SFR - 1997 UBC	Plan: 1821 A	2004
New	Approved Basic #03-106909 BP	Plan: 1821 B Two Story SFR - 1997 UBC	2004
New	Two Story SFR - 1997 UBC	Plan: 1531 (Elev C)	2004
New	Two Story SFR - 1997 UBC	Plan: 2295 (Elev A)	2004
New	Two Story SFR - 1997 UBC	Plan: 2721 A	2004
New	Two Story SFR - 1997 UBC	Plan: 2255 (Elev A)	2004
New	Two Story SFR - 1997 UBC	Plan: 2021 (Elev C)	2004
New	Two Story SFR - 1997 UBC	Plan: 2265 (Elev A)	2004
New	Two Story SFR - 1997 UBC	Plan: 2111 Elev. (B)	2004
New	Approved Basic #03-106402 BP	Plan: 1841 C Two Story SFR - 1997 UBC	2004
New	Two Story SFR - 1997 UBC	Plan: 2141 B	2004
New	Two Story SFR - 1997 UBC	Plan: 3541 (Elev C)	2004
New	Approved Basic #03-104827 BP	Plan: 2421 (Elev. C) Two Story SFR - 1997 UBC	2004
New	Two Story SFR - 1997 UBC	Plan: 2811 B	2004
New	Two Story SFRw/attached garage	1997 UBC Plan: 3111 (Elev. C)	2004
New	Approved Basic #03-104826 BP	Plan: 2421 (Elev. B) Two Story SFR - 1997 UBC	2004
New	Approved Basic 04-118418BP 2 story SFR w/attached garage	2003 IRC Plan:2141C	2004

Accessory Dwelling Units

Index # - File Name: 1.0022 - Single Family Dwellings Data\_Snohomish County.pdf

New	Two Story SFR - 1997 UBC	Plan: 2421 (Elev. B)	2004
New	Two Story SFR - 1997 UBC	Plan: 3531 (Elev C)	2004
New	Two Story SFR - 1997 UBC	Plan: 3511 (Elev B)	2004
New	Approved Basic #04-100111 BP	Plan: 2011 A Two Story SFR - 1997 UBC	2004
New	Two Story SFR - 1997 UBC	Plan: 2585 (Elev A)	2004
New	Approved Basic #03-104827 BP	Plan: 2421 (Elev. C) Two Story SFR - 1997 UBC	2004
New	Two Story SFR - 1997 UBC	Plan: 2011 A	2004
New	Approved Basic #03-106910 BP	Plan: 1821 (Elev C) Two Story SFR - 1997 UBC	2004
New	Two Story SFR - 1997 UBC	Plan: 2011 (Elev B)	2004
New	Approved Basic #03-106908 BP	Plan: 1821 (Elev A) Two Story SFR - 1997 UBC	2004
New	Approved Basic #03-106910 BP	Plan: 1821 (Elev C) Two Story SFR - 1997 UBC	2004
New	Approved Basic 04-120111BP	2 story SFR w/attached garage 2003 IRC Plan:3551B	2004
New	Two Story SFR - 1997 UBC	Plan: 3511 (Elev C)	2004
New	Two Story SFR - 1997 UBC	Plan: 2821 (Elev. B)	2004
New	Approved Basic #03-105913 BP	Plan: 2585 (Elev A) Two Story SFR - 1997 UBC	2004
New	Approved Basic #03-106910 BP	Plan: 1821 (Elev C) Two Story SFR - 1997 UBC	2004
New	Approved Basic #04-100393 BP	Plan 3025 A Two Story SFR - 1997 UBC	2004
New	Approved Basic 04-120242BP	Plan: 3210A3F-1 Two-story SFR with 3-car g	2004
New	Approved Basic #03-108244 BP	Plan: 2870 Two Story SFR - 1997 UBC	2004
New	Approved Basic #04-108606 BP	Plan 3210 A3F-1 Two Story SFR - 1997 UBC	2004
New	Approved Basic 04-117597BP	2 story SFR w/attached garage 2003 IRC Plan:3575	2004
New	Approved Basic #03-104911 BP	Plan #3105 Two Story SFR - 1997 UBC	2004
New	Approved Basic #03-102794 BP	Plan: 1966 - revised Rambler Style SFR - 1997 UE	2004
New	Approved Basic 04-120237BP	Plan: 3510 Two-story SFR with attached 3-car	2004
New	Approved Basic #04-100142 BP	Plan: 1758 Two Story SFR - 1997 UBC	2004
New	Approved Basic #02-100274 BP	Plan: 1710 Two Story SFR - 1997 UBC Option	2004
New	Approved Basic 03-109466 BP	Plan:D1703 Two Story SFR - 1997 UBC	2004
New	Approved Basic 04-111161BP	Plan: 1932 Two-story SFR - 2003 IRC	2004
New	Approved Basic #02-100274 BP	Plan: 1710 Two Story SFR - 1997 UBC Option	2004
New	Approved Basic #02-100832 BP	Plan: 1455 Split Level SFR - 1997 UBC	2004
New	Approved Basic #03-108344 BP	Plan: 1680 - 3 Two Story SFR - 1997 UBC	2004
New	Approved Basic #03-104421 BP	Plan: 1447 Rambler Style SFR - 1997 UBC	2004
New	Approved Basic #03-108344 BP	Plan: 1680 - 3 Two Story SFR - 1997 UBC	2004
New	Approved Basic #03-104421 BP	Plan: 1447 Rambler Style SFR - 1997 UBC	2004
New	Approved Basic #02-100273 BP	Plan: 2117 Split Level SFR - 1997 UBC Opti	2004
New	Approved Basic #03-104421 BP	Plan: 1447 Rambler Style SFR - 1997 UBC	2004
New	Approved Basic #02-100274 BP	Plan: 1710 Two Story SFR - 1997 UBC Option	2004
New	Approved Basic #02-100273 BP	Plan: 2117 Split Level SFR - 1997 UBC Opti	2004
New	Approved Basic #03-104418 BP	Plan: 1522 Rambler Style SFR - 1997 UBC	2004
New	Approved Basic #01-105212 BP	Plan: 1538 Two Story SFR - 1997 UBC	2004
New	Approved Basic #02-100274 BP	Plan: 1710 Two Story SFR - 1997 UBC Option	2004
New	Approved Basic #02-100273 BP	Plan: 2117 Split Level SFR - 1997 UBC Opti	2004
New	Approved Basic #01-105212 BP	Plan: 1538 Two Story SFR - 1997 UBC	2004
New	Two story SFR with Attached garage - 2003 IBC		2004
New	2-story SFR w/garage		2004
New	2-story SFR w/garage		2004
New	2-story SFR w/garage		2004



Accessory Dwelling Units

Index # - File Name: 1.0022 - Single Family Dwellings Data\_Snohomish County.pdf

New	Approved Basic 04-109404BP	1197 UBC	Plan #3484A	2 Story SFR with attached garage	2004
New	2-Story SFR w/attached garage.				2004
New	Approved Basic 04-109402BP	1997 UBC	Plan #3370	2 Story SFR with attached	2004
New	2-Story SFR w/attached garage.				2004
New	2-Story SFR w/attached garage.				2004
New	Two Story SFR - 1997 UBC		Plan: M3180A3S-IR		2004
New	Two Story SFR - 1997 UBC		Plan: M3210A3S-3		2004
New	2-story w/garage				2004
New	2-story SFR w/garage				2004
New	Rambler style SFR w/attached garage.				2004
New	2-story SFR w/garage				2004
New	Two Story SFR - 1997 UBC				2004
New	Two Story SFR - 1997 UBC				2004
New	Three bedroom SFR rambler				2004
New	2-story w/garage				2004
New	Two-story SFR - 1997 UBC		Plan: 2539		2004
New	Approved Basic #03-106298 BP		Plan: So Carolina w/o Den	Two Story SFR - 1997 UB	2004
New	Two Story SFR - 1997 UBC		Plan: 2539-S		2004
New	2 Story w/ 3 Car				2004
New	2-Story SFR over finished daylight basement w/attached garage.				2004
New	2-story w/garage - 2003 IRC				2004
New	2-story w/garage				2004
New	Two-story SFR - 1997UBC		Plan: MU3-2636		2004
New	Two-story SFR - 1997UBC		Plan: MU3-2850		2004
New	Approved Basic #03-104264 BP		Plan: 2815	Two Story SFR - 1997 UBC	2004
New	Two Story SFR with Attached Garage				2004
New	Two-story SFR with finished daylight basement - 1997 UBC		Plan: 3568 A		2004
New	2-story SFR w/garage				2004
New	2-story w/garage				2004
New	2-Story SFR w/attached garage.				2004
New	2-story w/garage				2004
New	2-Story SFR w/attached garage.				2004
New	Approved Basic #04-108819 BP		Plan: 2677 R-2	Two Story SFR - 1997 UBC	2004
New	Approved Basic 04-114123BP		Plan: 3232B R1, R2, R4	Two-story SFR - 199	2004
New	Approved Basic 04-114119BP		Plan: 3232 R3	Two-story SFR - 1997UBC	2004
New	Approved Basic #04-108831 BP		Plan: 3232 R-3	Two Story SFR - 1997 UBC	2004
New	Approved Basic #04-108831 BP		Plan: 3232 R-3	Two Story SFR - 1997 UBC	2004
New	Approved Basic 04-114119BP		Plan: 3232 R3	Two-story SFR - 1997UBC	2004
New	2 Story SFR with attached garage - 1997 UBC				2004
New	Two story SFR		Plan # 2275		2004
New	Two story SFR		Plan # 2275		2004
New	1480sf Rambler - 1997UBC				2004
New	Two Story SFR with 324 Sq Ft Unfinished Basement and Attached Garages				2004
New	Approved Basic #04-108796 BP		Plan: 2160 R-3	Two Story SFR - 1997 UBC	2004
New	Approved Basic #04-108831 BP		Plan: 3232 R-3	Two Story SFR - 1997 UBC	2004
New	Two Story SFR - 1997 UBC		Plan 2676 R-2		2004
New	Two Story SFR - 1997 UBC		Plan: 2949 R-3		2004

Accessory Dwelling Units

Index # - File Name: 1.0022 - Single Family Dwellings Data\_Snohomish County.pdf

New	Two Story SFR - 1997 UBC	Plan: 3232 R-3	2004
New	2-Story SFR w/attached garage.		2004
New	2 Story SFR w/ 3 Car		2004
New	Two Story SFR with Attached Garage		2004
New	Two Story Single Family Residence		2004
New	2 story single family with 3 car garage		2004
New	Two-story SFR - 1997UBC	Plan: 3550	2004
New	Approved Basic #04-108831 BP	Plan: 3232 R-3 Two Story SFR - 1997 UBC	2004
New	Approved Basic #04-108819 BP	Plan: 2677 R-2 Two Story SFR - 1997 UBC	2004
New	Two Story SFR - 1997 UBC	Plan: 2677 R-1	2004
New	Approved Basic #04-108787 BP	Plan: 2054 R-1 Two Story SFR 1997 UBC	2004
New	Two Story SFR - 1997 UBC	Plan: 2054 R-1	2004
New	Approved Basic #04-108826 BP	Plan: 2949 R-3 Two Story SFR - 1997 UBC	2004
New	Approved Basic #04-108791 BP	Plan: 2054 R-3 Two Story SFR 1997 UBC	2004
New	Approved Basic #04-108819 BP	Plan: 2677 R-2 Two Story SFR - 1997 UBC	2004
New	Approved Basic #04-108791 BP	Plan: 2054 R-3 Two Story SFR 1997 UBC	2004
New	Two Story SFR - 1997 UBC	Plan: 2160 R-3	2004
New	Approved Basic #04-108793 BP	Plan: 2160 R-1 Two Story SFR - 1997 UBC	2004
New	Approved Basic #04-108831 BP	Plan: 3232 R-3 Two Story SFR - 1997 UBC	2004
New	Approved Basic #04-108831 BP	Plan: 3232 R-3 Two Story SFR - 1997 UBC	2004
New	Two Story Duplex - 1997 UBC	Plan: D-301	2004
New	Approved Basic #04-100233 BP	Plan: D 301 Two Story Duplex - 1997 UBC	2004
New	Approved Basic #04-100233 BP	Plan: D 301 Two Story Duplex - 1997 UBC	2004
New	Approved Basic #04-100233 BP	Plan: D 301 Two Story Duplex - 1997 UBC	2004
New	Approved Basic #04-100233 BP	Plan: D 301 Two Story Duplex - 1997 UBC	2004
New	Approved Basic #04-100233 BP	Plan: D 301 Two Story Duplex - 1997 UBC	2004
New	Approved Basic #04-100233 BP	Plan: D 301 Two Story Duplex - 1997 UBC	2004
New	Approved Basic #04-100233 BP	Plan: D 301 Two Story Duplex - 1997 UBC	2004
New	Approved Basic #04-100233 BP	Plan: D 301 Two Story Duplex - 1997 UBC	2004
New	Two story - 1997 UBC		2004
New	Daylight Rambler SFR		2004
New	2-Story SFR w/attached garage.		2004
New	2 story single family residence		2004
New	Two-story SFR with attached 3-car garage		2004
New	Two Story SFR - 1997 UBC		2004
New	Two-story SFR - 1997UBC		2004
New	40 x 70 2004 Champion		2004
New	Approved Basic #04-108826 BP	Plan: 2949 R-3 Two Story SFR - 1997 UBC	2004
New	Approved Basic #04-108826 BP	Plan: 2949 R-3 Two Story SFR - 1997 UBC	2004
New	Approved Basic #04-108831 BP	Plan: 3232 R-3 Two Story SFR - 1997 UBC	2004
New	Approved Basic #04-108831 BP	Plan: 3232 R-3 Two Story SFR - 1997 UBC	2004
New	Approved Basic #04-108826 BP	Plan: 2949 R-3 Two Story SFR - 1997 UBC	2004
New	Approved Basic #04-108831 BP	Plan: 3232 R-3 Two Story SFR - 1997 UBC	2004
New	Approved Basic #04-108823 BP	Plan: 2469 R-3 Two-story SFR - 1997UBC	2004
New	Approved Basic #04-108826 BP	Plan: 2949 R-3 Two Story SFR - 1997 UBC	2004
New	Approved Basic 04-115720BP	Plan: 3232 Two-story SFR - 2003 IRC	2004
New	Approved Basic #04-108831 BP	Plan: 3232 R-3 Two Story SFR - 1997 UBC	2004

Accessory Dwelling Units

Index # - File Name: 1.0022 - Single Family Dwellings Data\_Snohomish County.pdf

New	Approved Basic #04-108831 BP	Plan: 3232 R-3	Two Story SFR - 1997 UBC	2004
New	Approved Basic #04-108826 BP	Plan: 2949 R-3	Two Story SFR - 1997 UBC	2004
New	Approved Basic #04-108831 BP	Plan: 3232 R-3	Two Story SFR - 1997 UBC	2004
New	Rambler Style SFR - 1997 UBC	Plan: 1856 R-1		2004
New	Approved Basic #04-108796 BP	Plan: 2160 R-3	Two Story SFR - 1997 UBC	2004
New	Tri Level SFR with 728 SF Fin Basement and 375 SF Unfinished and Attached Garage		2003 IRC	2004
New	Approved Basic #03-108705 BP	Plan #2009	Two Story SFR - 1997 UBC	2004
New	2-Story SFR w/attached garage.			2004
New	Two Story SFR with Basement and Attached Garage			2004
New	Two Story SFR with Finished Basement and Attached Garage			2004
New	Approved Basic #03-110621 BP	Plan: 2396	Two Story SFR - 1997 UBC	2004
New	2 story single family with garage			2004
New	Approved Basic #03-108774 BP	Plan #2402	Two Story SFR - 1997 UBC	2004
New	2 Story Single Family Residence 1997 UBC	builder plan number DJ36A		2004
New	Approved Basic #03-110621 BP	Plan: 2396	Two Story SFR - 1997 UBC	2004
New	2 story single family residence 1997 UBC	builder plan 37		2004
New	Rambler style single family residence UBC 1997	Plan 34		2004
New	Rambler style single family residence 1997 UBC	Builder plan number 35		2004
New	Approved Basic #03-108774 BP	Plan #2402	Two Story SFR - 1997 UBC	2004
New	Approved Basic #03-110621 BP	Plan: 2396	Two Story SFR - 1997 UBC	2004
New	Rambler style SFR w/attached garage.			2004
New	2 story single family residence 1997 UBC	builders plan DJ37		2004
New	Two Story SFR with Attached Garage			2004
New	2 story SFR w/attached garage	2003 UBC		2004
New	2 story single family residence 1997 UBC	Builder plan number		2004
New	SFR with 1040 sq ft Ufinished Basement and 1000 sq ft Garage			2004
New	Approved Basic 04-109541BP	Plan: 2459 A3F-0	Two Story SFR - 1997 UBC	2004
New	Two Story SFR with Attached Garage			2004
New	2 story single family residence 1997 UBC			2004
New	Two-story Duplex - 1997UBC			2004
New	Two-story duplex - 1997UBC			2004
New	1903sf SFR with 1832sf semi-finished daylight basement - 1997UBC			2004
New	MICRO 03/07 2 story SFR w/attached garage	2003 IRC		2004
New	Approved Basic 04-109541BP	Plan: 2459 A3F-0	Two Story SFR - 1997 UBC	2004
New	Two Story SFR with Attached Garage	Builders Plan #2459		2004
New	2 story single family residence			2004
New	Approved Basic 04-109541BP	Plan: 2459 A3F-0	Two Story SFR - 1997 UBC	2004
New	2-Story SFR w/attached garage.			2004
New	Two Story Duplex with Attached Garage			2004
New	1986 27x52 Fleetwood			2004
New	Approved Basic #03-105820 BP	Plan: 2830	Two Story SFR - 1997 UBC	2004
New	Approved Basic #03-105820 BP	Plan: 2830	Two Story SFR - 1997 UBC	2004
New	28 x 44 1988 Guerdon Esquire Mobile Home			2004
New	Approved Basic #03-106818 BP	Plan: 2896	Two-story SFR - 1997 UBC	2004
New	Approved Basic #99-103777BP	Plan: 2415 A/3	Two Story SFR - 1997 UBC	2004
New	Two Story SFR - 1997 UBC	Plan: 2403		2004
New	Approved Basic #99-103777BP	Plan: 2415 A/3	Two Story SFR - 1997 UBC	2004

Accessory Dwelling Units

Index # - File Name: 1.0022 - Single Family Dwellings Data\_Snohomish County.pdf

New	Approved Basic #03-106818 BP	Plan: 2896 Two-story SFR - 1997 UBC	2004
New	Approved Basic #99-103777BP	Plan: 2415 A/3 Two Story SFR - 1997 UBC	2004
New	Approved Basic #03-106818 BP	Plan: 2896 Two-story SFR - 1997 UBC	2004
New	Approved Basic #03-105820 BP	Plan: 2830 Two Story SFR - 1997 UBC	2004
New	Approved Basic #03-107115 BP	Plan: 1932 SFRw/semi-finsihed basement - 1997 U	2004
New	Two-story SFR - 1997UBC		2004
New	Approved Basic #03-107115 BP	Plan: 1932 SFRw/semi-finsihed basement - 1997 U	2004
New	Two Story SFR - 1997 UBC	Plan: 2842 - A	2004
New	Approved Basic #03-106921 BP	Plan: 2760 Two Story SFR - 1997 UBC	2004
New	Approved Basic #03-105279-BP	Plan: 2535 Two Story SFR - 1997 UBC	2004
New	Two Story SFR - 1997 UBC	Plan: 2982	2004
New	Ramber with attached garage		2004
New	Approved Basic #03-109293 BP	Plan: 3271 B Two Story SFR - 1997 UBC	2004
New	Approved Basic #03-109294 BP	Plan: 2996 A Two Story SFR - 1997 UBC	2004
New	Approved Basic #03-109295 BP	Plan: 2996 B Two Story SFR - 1997 UBC	2004
New	Approved Basic #03-109294 BP	Plan: 2996 A Two Story SFR - 1997 UBC	2004
New	Two Story SFR - 1997 UBC	Plan: 3000 B	2004
New	Approved Basic #03-109293 BP	Plan: 3271 B Two Story SFR - 1997 UBC	2004
New	Approved Basic #03-108830 BP	Plan: 2842 - B Two Story SFR - 1997 UBC	2004
New	Approved Basic #03-109295 BP	Plan: 2996 B Two Story SFR - 1997 UBC	2004
New	Approved Basic #03-109258 BP	Plan: 3000 A Two Story SFR - 1997 UBC	2004
New	Approved Basic #03-109292 BP	Plan: 3271 A Two Story SFR - 1997	2004
New	Approved Basic #03-109293 BP	Plan: 3271 B Two Story SFR - 1997 UBC	2004
New	Approved Basic #02-110377 BP	Plan 2006 Two Story SFR - 1997 UBC	2004
New	Approved Basic #02-110377 BP	Plan 2006 Two Story SFR - 1997 UBC	2004
New	Approved Basic #02-103159 BP	Plan: 2180 SSI Two Story SFR - 1997 UBC	O1 2004
New	28 x 68 2002 Redman Discovery		2004
New	Approved Basic #03-105123 BP	Plan: B3a Two-story SFR - 1997 UBC	2004
New	Approved Basic #03-105121 BP	Plan: B2a Two-story SFR - 1997 UBC	2004
New	Approved Basic #03-105123 BP	Plan: B3a Two-story SFR - 1997 UBC	2004
New	Approved Basic #03-105121 BP	Plan: B2a Two-story SFR - 1997 UBC	2004
New	Approved Basic #03-105123 BP	Plan: B3a Two-story SFR - 1997 UBC	2004
New	Approved Basic 03-102960 BP	Plan: D1a Two-story SFR - 1997UBC	2004
New	Approved Basic #03-105123 BP	Plan: B3a Two-story SFR - 1997 UBC	2004
New	Approved Basic #03-105122 BP	Plan: A1a Two-story SFR - 1997 UBC	2004
New	Approved Basic 03-102959BP	Plan A2a Two-story SFR - 1997 UBC	2004
New	Approved Basic #03-105123 BP	Plan: B3a Two-story SFR - 1997 UBC	2004
New	Approved Basic #03-105121 BP	Plan: B2a Two-story SFR - 1997 UBC	2004
New	Approved Basic #03-105121 BP	Plan: B2a Two-story SFR - 1997 UBC	2004
New	Approved Basic #03-108231 BP	Plan: B-5 Two Story SFR - 1997 UBC	2004
New	Approved Basic #03-105119 BP	Plan: B1b Two-story SFR - 1997 UBC	2004
New	Approved Basic #03-105123 BP	Plan: B3a Two-story SFR - 1997 UBC	2004
New	Approved Basic #03-105121 BP	Plan: B2a Two-story SFR - 1997 UBC	2004
New	2-story w/garage		2004
New	2-level SFR + loft and attached garage on top..		2004
New	Two Story SFR with Attached Garage		2004
New	Approved Basic #03-104321 BP	Plan: 2300 B Two Story SFR - 1997 UBC	2004

Accessory Dwelling Units

Index # - File Name: 1.0022 - Single Family Dwellings Data\_Snohomish County.pdf

New	2 story single family residence	2003 IRC				2004
New	Two-story SFR	- 1997UBC				2004
New	Rambler style SFR	w/attached garage.				2004
New	2-story w/unfinished basement					2004
New	28 x 70	- 1996 - Redmond - Mobile home.				2004
New	Approved Basic 04-109960BP	2 story SFR - 1997UBC	1997 UBC	Plan:#18C		2004
New	Approved Basic 04-109958BP	2 story SFR	1997 UBC	Plan:#21		2004
New	Approved Basic 04-109960BP	2 story SFR - 1997UBC	1997 UBC	Plan:#18C		2004
New	Approved Basic 04-110668BP	2 story SFR w/attached garage	1997 UBC	Plan#2295A Sta		2004
New	Approved Basic 04-110662BP	2 story SFR w/attached garage	1997 UBC	Plan :2125 A		2004
New	Approved Basic 04-109960BP	2 story SFR - 1997UBC	1997 UBC	Plan:#18C		2004
New	Approved Basic 04-109958BP	2 story SFR	1997 UBC	Plan:#21		2004
New	Approved Basic #03-107210 BP	Plan: 1763 A	Two Story SFR - 1997 UBC			2004
New	Approved Basic 04-110668BP	2 story SFR w/attached garage	1997 UBC	Plan#2295A St		2004
New	Approved Basic 04-109958BP	2 story SFR	1997 UBC	Plan:#21		2004
New	Approved Basic #01-101344 BP	Plan: 1460 S	SFR w/finished lower floor - 1997 UBC			2004
New	Rambler Style SFR	- 1997 UBC				2004
New	Approved Basic #02-108111 BP	Plan: #1818/Getchell - RFPI joist	Rambler style SFR 1997			2004
New	Approved Basic #03-104791 BP	Plan: Getchell	Rambler Style SFR - 1997 UBC			2004
New	Two story SFR with attached garage and finished basement					2004
New	Rambler style SFR	w/garage				2004
New	2-Story SFR	w/attached garage.				2004
New	Approved Basic #03-109466 BP	Plan: D 1703	Two Story SFR - 1997 UBC			2004
New	2-story SFR with unfinished basement	- 1997UBC				2004
New	Approved Basic 04-111161BP	Plan: 1932	Two-story SFR - 2003 IRC			2004
New	Approved Basic 04-111161BP	Plan: 1932	Two-story SFR - 2003 IRC			2004
New	Approved Basic 04-117593BP	2 story SFR w/attached garage	2003 IRC	Plan:1529		2004
New	Approved Basic #03-105078 BP	Plan: C	Two Story SFR - 1997 UBC			2004
New	Approved Basic #03-105077 BP	Plan: B	Two Story SFR - 1997 UBC			2004
New	2 story SFR w/attached garage	1997 UBC	Plan:Rose 8			2004
New	Approved Basic #03-105078 BP	Plan: C	Two Story SFR - 1997 UBC			2004
New	Approved Basic #03-105077 BP	Plan: B	Two Story SFR - 1997 UBC			2004
New	Two Story SFR	- 1997 UBC				2004
New	Approved Basic #02-100274 BP	Plan: 1710	Two Story SFR - 1997 UBC	Option		2004
New	Approved Basic #03-105143 BP	Plan # J2060	Two Story SFR - 1997 UBC			2004
New	Approved Basic #02-100274 BP	Plan: 1710	Two Story SFR - 1997 UBC	Option		2004
New	Approved Basic #02-100274 BP	Plan: 1710	Two Story SFR - 1997 UBC	Option		2004
New	Approved Basic 04-115367BP	2 story SFR w/attached garage	2003 IRC	Plan:1932 ALT		2004
New	Approved Basic 04-115367BP	2 story SFR w/attached garage	2003 IRC	Plan:1932 ALT		2004
New	Approved Basic #02-100274 BP	Plan: 1710	Two Story SFR - 1997 UBC	Option		2004
New	Approved Basic #01-111402 BP	Plan: 1680-revised engineering	Two-Story style SFR..			2004
New	Approved Basic #02-100274 BP	Plan: 1710	Two Story SFR - 1997 UBC	Option		2004
New	Approved Basic #02-100274 BP	Plan: 1710	Two Story SFR - 1997 UBC	Option		2004
New	Approved Basic 04-111161BP	Plan: 1932	Two-story SFR - 2003 IRC			2004
New	Approved Basic #02-100274 BP	Plan: 1710	Two Story SFR - 1997 UBC	Option		2004
New	Approved Basic 04-115367BP	2 story SFR w/attached garage	2003 IRC	Plan:1932 ALT		2004
New	Approved Basic 04-115367BP	2 story SFR w/attached garage	2003 IRC	Plan:1932 ALT		2004

Accessory Dwelling Units

Index # - File Name: 1.0022 - Single Family Dwellings Data\_Snohomish County.pdf

New	Approved Basic #02-100273 BP	Plan: 2117 Split Level SFR	1997 UBC	2004
New	Approved Basic #02-100274 BP	Plan: 1710 Two Story SFR -	1997 UBC Option	2004
New	Approved Basic 04-115367BP	2 story SFR w/attached garage	2003 IRC Plan:1932 ALT	2004
New	Approved Basic #02-100274 BP	Plan: 1710 Two Story SFR -	1997 UBC Option	2004
New	Approved Basic #03-105143 BP	Plan # J2060 Two Story SFR -	1997 UBC	2004
New	Approved Basic 04-116614BP	2 story SFR w/attached garage	2003 IRC Plan#1710ALT	2004
New	Approved Basic 04-111161BP	Plan: 1932 Two-story SFR -	2003 IRC	2004
New	Approved Basic #02-100832 BP	Plan: 1455 Split Level SFR -	1997 UBC	2004
New	Approved Basic #03-105143 BP	Plan # J2060 Two Story SFR -	1997 UBC	2004
New	Approved Basic #03-104421 BP	Plan: 1447 Rambler Style SFR -	1997 UBC	2004
New	Approved Basic #01-105212 BP	Plan: 1538 Two Story SFR -	1997 UBC	2004
New	Approved Basic #02-109388 BP	Plan: 1575 Tri-Level SFR -	1997 UBC Opt	2004
New	Approved Basic #02-100273 BP	Plan: 2117 Split Level SFR -	1997 UBC Opti	2004
New	Approved Basic #02-100273	Plan: 2117 Split Level SFR	1997 UBC Option: Sound Rec	2004
New	Approved Basic 03-109466 BP	Plan: D1703 Two Story SFR -	1997 UBC	2004
New	Approved Basic #01-111402 BP	Plan: 1680-revised engineering	Two-Story style SFR..	2004
New	Approved Basic #03-109315 BP	Plan: 1575 BSMT Two Story SFR w/	finished basement-	2004
New	Approved Basic #02-100274 BP	Plan: 1710 Two Story SFR -	1997 UBC Option	2004
New	Approved Basic 03-109466 BP	Plan: D1703 Two Story SFR -	1997 UBC	2004
New	Approved Basic #02-100274 BP	Plan: 1710 Two Story SFR -	1997 UBC Option	2004
New	Approved Basic #03-109315 BP	Plan: 1575 BSMT Two Story SFR w/	finished basement-	2004
New	Approved Basic #01-111402 BP	Plan: 1680-revised engineering	Two-Story style SFR..	2004
New	Approved Basic #03-105215 BP	Plan: D Two Story SFR -	1997 UBC	2004
New	Approved Basic #03-105215 BP	Plan: D Two Story SFR -	1997 UBC	2004
New	Approved Basic #03-105215 BP	Plan: D Two Story SFR -	1997 UBC	2004
New	Approved Basic #03-105215 BP	Plan: D Two Story SFR -	1997 UBC	2004
New	Approved Basic #03-105077 BP	Plan: B Two Story SFR -	1997 UBC	2004
New	Approved Basic #03-105076 BP	Plan: C-4 Two Story SFR -	1997 UBC	2004
New	Approved Basic #03-105078 BP	Plan: C Two Story SFR -	1997 UBC	2004
New	Approved Basic #03-105076 BP	Plan: C-4 Two Story SFR -	1997 UBC	2004
New	Approved Basic #03-105215 BP	Plan: D Two Story SFR -	1997 UBC	2004
New	Approved Basic #03-105077 BP	Plan: B Two Story SFR -	1997 UBC	2004
New	Approved Basic #03-105078 BP	Plan: C Two Story SFR -	1997 UBC	2004
New	Approved Basic #03-105077 BP	Plan: B Two Story SFR -	1997 UBC	2004
New	Approved Basic #03-105215 BP	Plan: D Two Story SFR -	1997 UBC	2004
New	Approved Basic #03-105077 BP	Plan: B Two Story SFR -	1997 UBC	2004
New	Approved Basic 04-116045-BP	2 story SFR w/attached 3-car garage	2003 IRC Bldr s. P	2004
New	Approved Basic #98-150628BP	Plan: 50 er Two Story SFR -	1997 UBC	2004
New	2004 27x66 Silvercrest			2004
New	Two story SFR with attached garage	2003 IRC		2004
New	2130 sq ft Daylight Rambler -	1997 UBC		2004
New	Approved Basic #01-106982 BP	Plan: 1705 crawl (revised)	SFR w/finished lo	2004
New	Two Story SFR with Attached Garage			2004
New	Approved Basic #01-111494 BP	Bldr Plan SSI 2792 Two-story style SFR....	1997 UBC	2004
New	Approved Basic #01-111603 BP	Bldr Plan 2968 Two-story style SFR.....	1997 UBC	2004
New	Approved Basic #01-104726 BP	Plan # 45 2673 Two-story style SFR.....	1997 UBC	2004
New	Rambler Style SFR -	1997 UBC		2004

Accessory Dwelling Units

Index # - File Name: 1.0022 - Single Family Dwellings Data\_Snohomish County.pdf

New	2 Story SFR with attached garage and enclosed pool		2004
New	Two Story SFR - 1997 UBC	Plan #3012	2004
New	2 story SFR w/attached garage	1997 UBC Plan:4010DB-C	2004
New	2 story SFR w/attached garage	1997 UBC Plan :4008C	2004
New	2-story SFR w/garage		2004
New	Two-story SFR - 1997 UBC		2004
New	2-Story SFR over finished daylight basement w/attached garage -	1997 UBC	2004
New	2-Story SFR w/attached garage.		2004
New	Approved Basic #98-150984BP	Plan: 5911-B Two Story SFR - 1997 UBC	2004
New	Rambler with Bonus Room above Garage		2004
New	Four bedroom single family rambler		2004
New	Four bedroom 2 story single family residence		2004
New	2-story w/garage		2004
New	2-story w/semi-finished basement & garage		2004
New	2 story single family residence with unfinished basement	1997 UBC	2004
New	SFR Rambler w/(unfinished) walk-out basement -	1997 UBC	2004
New	2-story SFR w/garage and unfinished basement		2004
New	Rambler style SFR -	1997 UBC	2004
New	Approved Basic 04-109361BP	2 story SFR w/attached garage 19997 UBC	2004
New	Approved Basic #03-106696 BP	Plan 2760 Two Story SFR - 1997 UBC	2004
New	Two story SFR with basement & attached garage	1997-UBC	2004
New	2 story SFR w/attached garage	1997 UBC	2004
New	Two-story SFR		2004
New	2656sf rambler -	1997UBC	2004
New	2 Story SFR with daylight basement and 3 car garage		2004
New	Rambler w/ finished basement	Called again and left message re: unpaid driveway fees 1-5-04 ;	2004
New	Single Family Residence		2004
New	Two-story SFR with attached garage -	2003 IRC	2004
New	Two Story SFR -	1997 UBC	2004
New	Two-story SFR w/garage	Plan: 3280	2004
New	Two Story SFR with attached garage		2004
New	Two Story SFR w/unfinished basement -	1997 UBC	2004
New	Daylight basement Rambler w/attached garage.		2004
New	Approved Basic #04-115976BP	Rambler with Attached Garage	2004
New	Approved Basic #03-104321 BP	Plan: 2300 B Two Story SFR - 1997 UBC	2004
New	Rambler style w/garage		2004
New	Two-story SFR -	1997 UBC	2004
New	Two Story SFR with attached garage		2004
New	Approved Basic #03-105768 BP	Plan: Rainier Two-story SFR with 1042 sf finish	2004
New	Approved Basic #03-105768 BP	Plan: Rainier Two-story SFR with 1042 sf finish	2004
New	2-Story SFR w/attached garage.	1997 UBC	2004
New	Rambler style SFR w/attached garage.		2004
New	Approved Basic #03-105768 BP	Plan: Rainier Two-story SFR with 1042 sf finish	2004
New	Approved Basic #04-100304 BP	Plan: Olympus II (Elev A) Two Stroy SFR w/semi-finish	2004
New	Two Story SFR with Finished Basement and Attached Garage		2004
New	Two Story SFR with Finished Basement and Attached Garage	2003 IRC	2004
New	Approved Basic #04-100304 BP	Plan: Olympus 1 Elev B Two Story SFR w/semi-finished	2004

Accessory Dwelling Units

Index # - File Name: 1.0022 - Single Family Dwellings Data\_Snohomish County.pdf

New	Approved Basic #04-100304 BP	Plan: Olympus II (Elev A)	Two Story SFR w/semi-finish	2004
New	Approved Basic #04-100301 BP	Plan: Olympus 1 (Elev. B)	Two Story SFR w/semi-finish	2004
New	Approved Basic #04-100304 BP	Plan: Olympus II (Elev A)	Two Story SFR w/semi-fir	2004
New	Two-story SFR with 1080sf semi-finished basement - 1997 UBC	Plan: Olympus		2004
New	Approved Basic #04-100304 BP	Plan: Olympus II (Elev A)	Two Story SFR w/semi-finish	2004
New	2270 Sq Ft SFR with Attached Garage			2004
New	Approved Basic #03-105768 BP	Plan: Rainier	Two-story SFR with 1042 sf finish	2004
New	Rambler style w/garage			2004
New	Two story SFR with attached garage			2004
New	Approved Basic 04-115827BP	2 story SFR w/attached garage	2003 IRC Plan:2968	2004
New	Two-story SFR -1997 UBC			2004
New	2-story SFR w/garage			2004
New	Approved 04-115824BP	2 story SFR w/attached garage	2003 IRC Plan:2611	2004
New	Approved Basic #01-111494 BP	Bldr Plan SSI 2792	Two-story style SFR....1997 UBC	2004
New	Two Story SFR with Attached Garage	1997 UBC		2004
New	Approved Basic 04-115827BP	2 story SFR w/attached garage	2003 IRC Plan:2968	2004
New	Approved Basic #01-107346 BP	Plan: SSI 2783	Two Story SFR - 1997 UBC	2004
New	Approved Basic 04-115827BP	2 story SFR w/attached garage	2003 IRC Plan:2968	2004
New	2-Story SFR w/garage	Plan # 3152	IBC 2003	2004
New	2-story SFR w/garage			2004
New	2 Story Single Family residence	Plan lot 27-4		2004
New	Two Story SFR with Attached Garage			2004
New	2660 square foot SFR with 3 car garage			2004
New	Approved Basic 04-115824BP	2 story SFR w/attached garage	2003 IRC Plan:2611	2004
New	2 Story w/ 3 Car			2004
New	Two Story SFR with Attached Garage			2004
New	Rambler w/ Semi finished Daylight basement & 3 Car Garage			2004
New	2 Story SFR w/garage	Plan #2722	2003 IBC	2004
New	2 story SFR with attached garage	---	1997 UBC	2004
New	Approved Basic #03-110297 BP	Plan 1130	Rambler Style Duplex - 1997 UBC	2004
New	66 X 30 mobile home			2004
New	Approved Basic #01-101544 BP	Plan: 2611 (51 2656)	Two Story SFR - 1997 UBC	2004
New	Two Story SFR - 1997 UBC	Plan: 3152		2004
New	Approved Basic #01-111603 BP	Bldr Plan 2968	Two-story style SFR....1997 UBC	2004
New	Approved Basic #01-101542 BP	Plan: 2349 (56 -2656)	Rambler Style SFR - 1997 UBC	2004
New	Approved Basic #03-105191 BP	Plan: 2783	Two Story SFR - 1997 UBC	2004
New	2-story w/garage			2004
New	Approved Basic #02-109212 BP	Plan: 2797	Two Story SFR - 1997 UBC	2004
New	Two Story SFR with Attached Garage			2004
New	Approved Basic #01-111603 BP	Bldr Plan 2968	Two-story style SFR....1997 UBC	2004
New	30x75 2002 Guerdon doublewide			2004
New	Approved Basic #03-110681 BP	Plan: 1706	Two Story SFR - 1997 UBC	2004
New	One-story SFR w/attached garage	1997 UBC		2004
New	SFR rambler with attached garage			2004
New	2 Story w/ 3 Car			2004
New	Approved Basic #02-109359 BP	Plan: 2443 B	Two Story SFR - 1997 UBC	2004
New	Approved Basic #98-110516BP	Option Approved:	Garage door design & entry cha	2004



Accessory Dwelling Units

Index # - File Name: 1.0022 - Single Family Dwellings Data\_Snohomish County.pdf

New	Approved Basic #02-109361 BP	Plan 2553 B	Two Story SFR - 1997 UBC	2004
New	Two Story SFR with 460 sq ft Finished Basement and Garage		1997 UBC	2004
New	Two Story SFR with 460 sq ft Finished Basement and Attached Garage		1997 UBC	2004
New	Approved Basic #02-109360 BP	Plan #2443A	Two Story SFR - 1997 UBC	2004
New	Approved Basic #02-109359 BP	Plan: 2443 B	Two Story SFR - 1997 UBC	2004
New	Two-story SFR w/attached garage -		1997 UBC	2004
New	Approved Basic #04-109142BP	Plan #2611	Two Story SFR - 1997 UBC	2004
New	2-story SFR w/garage			2004
New	Approved Basic #03-108344 BP	Plan: 1680 - 3 Bedroom	Two Story SFR - 1997 UBC	2004
New	Approved Basic #03-108822 BP	Plan: 1384	Two Story SFR - 1997 UBC	2004
New	1976 Gibraltar 12x60			2004
New	2 story SFR w/attached garage	2003 IRC	Plan: 4010DB-C-LG	2004
New	Rambler Style SFR -			2004
New	Two Story SFR with 1286 sq ft Unfinished Basement			2004
New	Approved Basic #01-105212 BP	Plan: 1538	Two Story SFR - 1997 UBC	2004
New	Approved Basic #01-105212 BP	Plan: 1538	Two Story SFR - 1997 UBC	2004
New	SFR w/finished basement & attached garage	2003 IRC	Plan:1909 Bsmt	2004
New	Approved Basic #03-104676 BP	Plan: 1680 w/basement	Two Story SFR w/finished ba	2004
New	2-story SFR w/finished basement & garage			2004
New	Two Story SFR -			2004
New	Approved Basic #03-108344 BP	Plan: 1680 - 3	Two Story SFR - 1997 UBC	2004
New	Approved Basic 04-116616BBP	2 story SFR w/attached garage	2003 IRC	Plan:1841
New	Approved Basic 04-116616BP	2 story SFR w/attached garage	2003 IRC	Plan:1841
New	Approved Basic 04-116616BP	2 story SFR w/attached garage	2003 IRC	Plan:1841
New	Approved Basic #03-106965 BP	Plan: 1339 Daylight	SFR w/finished basement - :	2004
New	Approved Basic 04-116090BP	Plan: 1339 Daylight	One-story SFR with unfini	2004
New	Approved Basic #03-106965 BP	Plan: 1339 Daylight	SFR w/finished basement - :	2004
New	Approved Basic #03-106965 BP	Plan: 1339 Daylight	SFR w/finished basement - :	2004
New	Approved Basic 04-116090BP	Plan: 1339 Daylight	One-story SFR with unfini	2004
New	Approved Basic #03-106965 BP	Plan: 1339 Daylight	SFR w/finished basement - :	2004
New	Approved Basic 04-116464BP	Plan: 1266 Daylight	SFR with finished daylig	2004
New	Approved Basic #03-106965 BP	Plan: 1339 Daylight	SFR w/finished basement - :	2004
New	Approved Basic 04-116464BP	Plan: 1266 Daylight	SFR with finished daylig	2004
New	Approved Basic 04-116464BP	Plan: 1266 Daylight	SFR with finished daylig	2004
New	Approved Basic 04-116464BP	Plan: 1266 Daylight	SFR with finished daylig	2004
New	Approved Basic 04-116464BP	Plan: 1266	SFR with finished daylight basem	2004
New	Approved Basic #03-106965 BP	Plan: 1339 Daylight	SFR w/finished basement - :	2004
New	Approved Basic #03-104579 BP	Plan: 1339	Rambler Style SFR - 1997 UBC	2004
New	Approved Basic #03-104579 BP	Plan: 1339	Rambler Style SFR - 1997 UBC	2004
New	Approved Basic #00-103622 BP	Plan: 1399 (slab)	Rambler Style SFR - 1997 UBC	2004
New	Approved Basic #01-112384 BP	Plan: 1253 slab (Elev B)	Rambler Style SFR - 199	2004
New	Approved Basic #00-103622 BP	Plan: 1399 (slab)	Rambler Style SFR - 1997 UBC	2004
New	Approved Basic #00-103621 BP	Plan: 1199 (slab)	Rambler Style SFR - 1997 UB	2004
New	Approved Basic #01-112384 BP	Plan: 1253 slab (Elev B)	Rambler Style SFR - 199	2004
New	Approved Basic #00-103622 BP	Plan: 1399 (slab)	Rambler Style SFR - 1997 UBC	2004
New	Approved Basic #00-103622 BP	Plan: 1399 (slab)	Rambler Style SFR - 1997 UBC	2004
New	Approved Basic 99-115181BP	Plan: 1199 (wood)	Rambler Style SFR - 1997 UB	2004

Accessory Dwelling Units

Index # - File Name: 1.0022 - Single Family Dwellings Data\_Snohomish County.pdf

New	Approved Basic #00-103622 BP	Plan: 1399 (slab) Rambler Style SFR - 1997 UBC	2004
New	Approved Basic #00-103622 BP	Plan: 1399 (slab) Rambler Style SFR - 1997 UBC	2004
New	Approved Basic #00-103622 BP	Plan: 1399 (slab) Rambler Style SFR - 1997 UBC	2004
New	Approved Basic #01-112384 BP	Plan: 1253 slab (Elev B) Rambler Style SFR - 1997 UBC	2004
New	Approved Basic #04-115875 BP	Rambler style w/garage...(2003 IRC/IBC)	2004
New	Approved Basic #04-115876 BP	Rambler style w/garage 2003 IRC	2004
New	Approved Basic 99-115181BP	Plan: 1199 (wood) Rambler Style SFR - 1997 UB	2004
New	Approved Basic #03-104579 BP	Plan: 1339 Rambler Style SFR - 1997 UBC	2004
New	Approved Basic #03-104579 BP	Plan: 1339 Rambler Style SFR - 1997 UBC	2004
New	Approved Basic 99-115184 BP	Plan: 1399 Rambler Style SFR - 1997 UBC	2004
New	Approved Basic #01-112384 BP	Plan: 1253 slab (Elev B) Rambler Style SFR - 1997 UBC	2004
New	Approved Basic #03-104579 BP	Plan: 1339 Rambler Style SFR - 1997 UBC	2004
New	Approved Basic #00-103622 BP	Plan: 1399 (slab) Rambler Style SFR - 1997 UBC	2004
New	Approved Basic #03-104579 BP	Plan: 1339 Rambler Style SFR - 1997 UBC	2004
New	Approved Basic #01-112384 BP	Plan: 1253 slab (Elev B) Rambler Style SFR - 1997 UBC	2004
New	Approved Basic #03-104579 BP	Plan: 1339 Rambler Style SFR - 1997 UBC	2004
New	Approved Basic #04-115875 BP	Plan: 1339 Rambler style w/garage...(2003 IRC/IBC)	2004
New	Approved Basic #04-115876 BP	Plan: 1253 Rambler style w/garage 2003 IRC	2004
New	Approved Basic 04-116091BP	Plan: 1300 Rambler with attached garage	2004
New	Approved Basic 04-116091BP	Plan: 1300 Rambler with attached garage	2004
New	Approved Basic 04-116091BP	Plan: 1300 Rambler with attached garage	2004
New	Approved Basic #04-115875 BP	Plan: 1339 Rambler style w/garage...(2003 IRC/IBC)	2004
New	Approved Basic 04-116091BP	Plan: 1300 Rambler with attached garage	2004
New	Approved Basic #04-115875 BP	Plan: 1339 Rambler style w/garage...(2003 IRC/IBC)	2004
New	Approved Basic 99-115181BP	Plan: 1199 (wood) Rambler Style SFR - 1997 UB	2004
New	Approved Basic #01-112384 BP	Plan: 1253 slab (Elev B) Rambler Style SFR - 1997 UBC	2004
New	Approved Basic #00-103622 BP	Plan: 1399 (slab) Rambler Style SFR - 1997 UBC	2004
New	Approved Basic #01-112384 BP	Plan: 1253 slab (Elev B) Rambler Style SFR - 1997 UBC	2004
New	Approved Basic #00-103622 BP	Plan: 1399 (slab) Rambler Style SFR - 1997 UBC	2004
New	Approved Basic #03-104579 BP	Plan: 1339 Rambler Style SFR - 1997 UBC	2004
New	Approved Basic #01-112384 BP	Plan: 1253 slab (Elev B) Rambler Style SFR - 1997 UBC	2004
New	Approved Basic #03-104579 BP	Plan: 1339 Rambler Style SFR - 1997 UBC	2004
New	Approved Basic #00-103621 BP	Plan: 1199 (slab) Rambler Style SFR - 1997 UB	2004
New	Approved Basic #03-108244 BP	Plan: 2870 Two Story SFR - 1997 UBC	2004
New	Approved Basic #04-108873 BP	Plan: 2802 conv Two-story SFR - 1997 UBC	2004
New	2442 sq ft Rambler with attached garage		2004
New	Two Story SFR - 1997 UBC		2004
New	Rambler w/ 3 Car Garage - 1997 UBC		2004
New	1977 14 X 70 Single Wide MH		2004
New	Approved Basic 04-115048BP	Plan: 3106-3 2-story w/garage - 1997 UBC	2004
New	Approved Basic 04-115044BP	Plan: 3077-3 2-story w/garage - 1997 UBC	2004
New	Approved Basic #04-109013 BP	Plan: 3101 Two-story SFR - 1997 UBC	2004
New	Approved Basic 04-115050BP	Plan: 3352 2-story w/garage - 1997 UBC	2004
New	Two-story SFR - 1997UBC	Plan: 3106	2004
New	Approved Basic #03-104235 BP	Plan: 3151 Two Story SFR - 1997 UBC	2004
New	Approved Basic #03-104235 BP	Plan: 3151 Two Story SFR - 1997 UBC	2004
New	2-story SFR w/attached garage	1997 UBC Plan:3122	2004

Accessory Dwelling Units

Index # - File Name: 1.0022 - Single Family Dwellings Data\_Snohomish County.pdf

New	Two-story SFR - 1997 UBC	Plan: 3148	2004
New	Approved Basic # 04-110114 BP	Plan: 3324 Two Story SFR with attached garage - 19	2004
New	2-story SFR w/garage		2004
New	Approved Basic #03-108122 BP	Plan # 3259-3 Two Story SFR - 1997 UBC	2004
New	Approved Basic #04-109009 BP	Plan: 3101 Two-story SFR - 1997 UBC	2004
New	Approved Basic #03-108122 BP	Plan # 3259-3 Two Story SFR - 1997 UBC	2004
New	Two-story SFR 1997 UBC	Builder s Plan: 3683	2004
New	Two-story SFR - 1997UBC	Plan: 3352	2004
New	Two-story SFR - 1997 UBC		2004
New	Approved Basic #03-108122 BP	Plan # 3259-3 Two Story SFR - 1997 UBC	2004
New	Two story SFR with attached 3-car garage	1997 UBC	2004
New	Two-story SFR - 1997 UBC	Plan: 3077	2004
New	Approved Basic #03-108122 BP	Plan # 3259-3 Two Story SFR - 1997 UBC	2004
New	Two story SFR - 1997 UBC	Plan #: 3101	2004
New	Two story SFR		2004
New	Rambler style w/garage		2004
New	2-Story SFR w/attached garage.		2004
New	Two Story SFR - 1997 UBC		2004
New	Two-story SFR - 1997 UBC	Plan: M 2645 B3F-0	2004
New	1987 Liberty 28 x 70 Manufactured home		2004
New	29 L x 52 w. 1999 Palm Harbor Mobile		2004
New	Two Story SFR with Attached Garage		2004
New	SFR with finished daylight basement & attached garage - 2003 IRC		2004
New	Approved Basic #02-108383 BP	Plan: 2409 C Two Story SFR - 1997 UBC	2004
New	Approved Basic #03-107891 BP	Plan: 2300 A Two Story SFR - 1997 UBC	2004
New	Approved Basic #03-103340 BP	Plan: 2598 B Two Story SFR - 1997 UBC	2004
New	Approved Basic #03-107891 BP	Plan: 2300 A Two Story SFR - 1997 UBC	2004
New	Approved Basic #03-107891 BP	Plan: 2300 A Two Story SFR - 1997 UBC	2004
New	Rambler Style SFR with attached garage		2004
New	Two-story SFR	Builder s Plan 3279	2004
New	Two-story SFR - 1997 UBC	Builders Plan: Plan 1	2004
New	Rambler SFR		2004
New	new SFR, w/attached garage & 2-nd floor bonus room		2004
New	Approved Basic #04-116534BP	Plan:2274 Rambler style w/garage (2003 IRC	2004
New	Approved Basic 04- 117174BP	Builders Plan #2952 2 Story w/attached	2004
New	Approved Basic #04-116534BP	Plan:2274 Rambler style w/garage (2003 IRC	2004
New	2-Story SFR w/attached garage.		2004
New	One-story SFR	Builders Plan: R2822A3F-0	2004
New	One-story SFR with finished daylight basement - 1997UBC		2004
New	Approved Basic #02-104896 BP	Plan 2274 Rambler Style SFR -1997 UBC	2004
New	Two-story SFR - 1997 UBC	Builders Plan: Plan 1	2004
New	Two story SFR with Attached Garage		2004
New	Rambler Style SFR w/attached garage.		2004
New	Rambler style SFR w/garage		2004
New	Rambler Style SFR with attached garage		2004
New	Rambler with Atached Garage		2004
New	Two-story SFRw/attached garage 1997 UBC		2004

Accessory Dwelling Units

Index # - File Name: 1.0022 - Single Family Dwellings Data\_Snohomish County.pdf

New	2-Story over semi-finished daylight basement w/attached garage.			2004
New	2-Story SFR w/attached garage.			2004
New	Two Story SFR with Attached Garage - 1997 UBC	Plan: 2300		2004
New	Daylight Basement Rambler w/attached garage.	1997 UBC		2004
New	SFR with Daylight basement with Bonus room over garage			2004
New	Approved Basic #00-110423 BP	Bldrs Plan No. 9929	Two-story SFR.....1997 UBC	2004
New	Two story SFR with attached 4-car garage			2004
New	Approved Basic #02-109607 BP	Plan #2265 C/2-3	Two Story SFR - 1997 UBC	This pe 2004
New	Rambler w/semi fin bsmt & 3 Car			2004
New	Two Story SFR with Attached Garage	1997 UBC		2004
New	SFR with attached 3-car garage			2004
New	Approved Basic #03-105119 BP	Plan: B1b	Two-story SFR - 1997 UBC	2004
New	Approved Basic 05-116442BP	2003 IRC	Plan: C-GN 2 story SFR w/attached garage	2004
New	Approved Basic #03-105123 BP	Plan: B3a	Two-story SFR - 1997 UBC	2004
New	Approved Basic #03-105119 BP	Plan: B1b	Two-story SFR - 1997 UBC	2004
New	Approved Basic #03-105123 BP	Plan: B3a	Two-story SFR - 1997 UBC	2004
New	Approved Basic #03-105123 BP	Plan: B3a	Two-story SFR - 1997 UBC	2004
New	Approved Basic 03-102960 BP	Plan: D1a	Two-story SFR - 1997UBC	2004
New	2-Story SFR w/attached garage.			2004
New	2 Story w/ 3 Car			2004
New	Rambler w/ unfinished basement & 3 Car Garage			2004
New	2 story SFR w/attached garage	2003 IRC	Plan:CAMAS	2004
New	2-Story SFR over unfinished basement w/attached garage.			2004
New	2 story SFR w/attached garage	2003 IRC	Plan:Brooklyn	2004
New	Two-story SFR with attached garage - 2003 IRC	Plan: Harrington II		2004
New	Two Story with unfinished basement & attached garage			2004
New	Two-story SFR - 1997 UBC			2004
New	Approved Basic 04-118702BP	Plan: 0122	Two Story SFR w/attached 3-car gara	2004
New	2 Story w/ 3 Car			2004
New	2 Story w/ 3 Car Garage			2004
New	2-story SFR w/garage			2004
New	Approved Basic 04- 115894BP	Builders Plan #03012	2 Story w/ # Car	2004
New	Approved Basic 04-115896BP	Builders Plan #2271AC	2 Story w/ 3 Car	2004
New	Approved Basic #04-114690 BP	Plan: 04002-1	2-story w/garage (2003IRC/IBC)	2004
New	Approved Basic 04-115896BP	Builders Plan #2271AC	2 Story w/ 3 Car	2004
New	Approved Basic #04-114683 BP	Plan: 03120	2-story w/garage 2003 IRC	2004
New	Approved Basic 04-119744BP	2 story sfr w/attached 3 car garage	2003 IRC	Plan:22141 2004
New	Approved Basic 04- 115894BP	Builders Plan #03012	2 Story w/ # Car	2004
New	Approved basic #04-114690 BP	2-story w/attached garage	2003 IRC	2004
New	Approved Basic #04-114683 BP	Plan: 03120	2-story w/attached garage	2 2004
New	Two-story SFR - 2003 IRC			2004
New	Approved Basic #02-110621 BP	Plan: 1512	Rambler Style SFR - 1997 UBC	2004
New	Approved Basic #02-110621 BP	Plan: 1512	Rambler Style SFR - 1997 UBC	2004
New	Approved Basic #03-109934 BP	Plan: 2216	Two Story SFR - 1997 UBC	2004
New	Approved Basic #02-110621 BP	Plan: 1512	Rambler Style SFR - 1997 UBC	2004
New	Approved Basic #02-110621 BP	Plan: 1512	Rambler Style SFR - 1997 UBC	2004
New	Approved Basic #02-110621 BP	Plan: 1512	Rambler Style SFR - 1997 UBC	2004

Accessory Dwelling Units

Index # - File Name: 1.0022 - Single Family Dwellings Data\_Snohomish County.pdf

New	Approved Basic #03-109934 BP	Plan: 2216 Two Story SFR - 1997 UBC	2004
New	Approved Basic #03-109934 BP	Plan: 2216 Two Story SFR - 1997 UBC	2004
New	Approved Basic #02-110621 BP	Plan: 1512 Rambler Style SFR - 1997 UBC	2004
New	Approved 04-118946BP	Plan: 1791 Rambler-style SFR with attached	2004
New	Two-story SFR with attached 2-car garage - 2003IRC		2004
New	Approved Basic #02-110621 BP	Plan: 1512 Rambler Style SFR - 1997 UBC	2004
New	Approved Basic #03-109934 BP	Plan: 2216 Two Story SFR - 1997 UBC	2004
New	Approved Basic #02-110621 BP	Plan: 1512 Rambler Style SFR - 1997 UBC	2004
New	Approved Basic #02-110621 BP	Plan: 1512 Rambler Style SFR - 1997 UBC	2004
New	Approved Basic #03-109934 BP	Plan: 2216 Two Story SFR - 1997 UBC	2004
New	Approved Basic #02-110621 BP	Plan: 1512 Rambler Style SFR - 1997 UBC	2004
New	Approved Basic #03-109934 BP	Plan: 2216 Two Story SFR - 1997 UBC	2004
New	Approved Basic #02-110621 BP	Plan: 1512 Rambler Style SFR - 1997 UBC	2004
New	Approved Basic #03-109934 BP	Plan: 2216 Two Story SFR - 1997 UBC	2004
New	Approved Basic #02-110621 BP	Plan: 1512 Rambler Style SFR - 1997 UBC	2004
New	Approved Basic #02-110621 BP	Plan: 1512 Rambler Style SFR - 1997 UBC	2004
New	Approved Basic #03-109934 BP	Plan: 2216 Two Story SFR - 1997 UBC	2004
New	2 story (2363 square foot) single family residence		2004
New	2-Story SFR w/attached garage.		2004
New	SFR Rambler		2004
New	Split level style w/finished basement & garage		2004
New	Split level style w/finished basement & garage		2004
New	2 story SFR w/attached garage 2003 IRC	Plan:Aldarra II	2004
New	2 story SFR w/attached garage 2003 IRC	Plan:Legacy Plus	2004
New	Two Story SFR with 783 Sq Ft w/ unfinished Basement & Attached Garage	2003 IRC	2004
New	2-story SFR w/unfinished basement & attached garage		2004
New	2-story SFR w/garage		2004
New	Two-story SFR with attached garage - 2003 IRC	Camas Plan	2004
New	2 story SFR w/attached garage 2003 IRC	Plan:Legacy Plus	2004
New	2 story SFR w/attached garage 2003 IRC		2004
New	Approved Basic 04-117372BP	Builders Plan #24098 Rambler w/ 3 Car	2004
New	2-Story SFR w/attached garage.		2004
New	Two Story SFR with Attached Garage		2004
New	Two Story SFR with Attached Garage		2004
New	Approved Basic #03-104264 BP	Plan: 2815 Two Story SFR - 1997 UBC	Basic 2004
New	Two-story SFR with attached 3-car garage - 2003 IRC		2004
New	Approved Basic 04-111800BP	Plan: 3133 Two-story SFR - 1997 UBC	2004
New	2-story w/garage		2004
New	2-Story SFR w/attached garage.		2004
New	Approved Basic #04-108936 BP	Plan #2577 Two Story SFR - 1997 UBC	2004
New	Two Story SFR with Attached Garage		2004
New	Approved Basic #04-114683 BP	Plan: 03120 2-story w/garage	2003 IRC 2004
New	Two-story SFR - 1997 UBC		2004
New	Two Story SFR with 430 SF Finished and 689 SF Unfinished Basement and Garage		2004
New	Approved Basic 04-117372BP	Builders Plan #24098 Rambler w/ 3 Car	2004
New	2-Story SFR w/attached garage. 1997 UBC		2004
New	2 story SFR w/attached garage 2003 IRC	Plan: Roslyn A	2004

Accessory Dwelling Units

Index # - File Name: 1.0022 - Single Family Dwellings Data\_Snohomish County.pdf

New	Approved Basic 04-113513BP	2-story sfr w/garage	1997 UBC	Plan:Richmond	2004
New	2 story SFR w/attached garage	2003 IRC	Plan:Roslyn		2004
New	Approved Basic 04-111710 BP		Builder s Plan: Sierra 3-Car	Two-story SFR	2004
New	Approved Basic #03-110043 BP		Plan: Prescott B	Two-story SFR - 1997 UBC	2004
New	Approved Basic 04-113512BP	2-story sfr w/garage	1997 UBC	Plan:Presc	2004
New	Approved Basic 04-111710 BP		Builder s Plan: Sierra 3-Car	Two-story SFR	2004
New	Approved Basic 04-113513BP	2-story sfr w/garage	1997 UBC	Plan:Richmond	2004
New	2 story SFR w/attached garage	2003 IRC	Plan:Roslyn		2004
New	Approved Basic 04-115760BP		Plan: 2287	Two-story SFR - 2003 IRC	2004
New	Approved Basic #03-108992 BP		Plan: M 2590 A2F-1	Two-story SFR - 1997 UBC	2004
New	Approved Basic 04-115763BP		Plan: 2880	Two-story SFR - 2003 IRC	2004
New	Approved Basic 04-115760BP		Plan: 2287	Two-story SFR - 2003 IRC	2004
New	Approved Basic #03-108992 BP		Plan: M 2590 A2F-1	Two-story SFR - 1997 UBC	2004
New	Approved Basic 04-117616BP	2 story SFR w/attached garage	2003 IRC	Plan:2627	2004
New	Approved Basic 04-116585BP	2 story SFR w/attached garage	2003 IRC	Plan:2590A2F-11	2004
New	Approved Basic 04-116582BP	2 story SFR w/attached garage	2003 IRC	Plan:2274	2004
New	2-story SFR w/garage				2004
New	Approved Basic 04-111710 BP		Builder s Plan: Sierra 3-Car	Two-story SFR	2004
New	2 story SFR w/attached garage	2003 IRC	Plan: Roslyn B		2004
New	2 story single family residence with 2 car garage				2004
New	Approved Basic 04-115760BP		Plan: 2287	Two-story SFR - 2003 IRC	2004
New	Approved Basic 04-115763BP		Plan: 2880	Two-story SFR - 2003 IRC	2004
New	2 story SFR w/attached garage	2003 IRC			2004
New	Two story SFR with attached garage				2004
New	Two story SFR with attached garage				2004
New	2-story SFR w/attached garage	1997 UBC			2004
New	2 story single family residence with 2 car garage				2004
New	Two Story SFR with Attached Garage	2003 IRC			2004
New	Two-story SFR - 1997 UBC		Builders Plan: Pilchuck		2004
New	Two-story SFR - 1997 UBC		Builders Plan: Shucksan		2004
New	Two-story SFR - 1997 UBC		Builders Plan: Pilchuck		2004
New	Two-story SFR - 1997 UBC		Builders Plan: Shucksan		2004
New	Two-story SFR - 1997 UBC		Builders Plan: Shucksan		2004
New	Split entry style SFR w/finished basement				2004
New	Rambler style SFR				2004
New	2 story single family residence - 1997 UBC				2004
New	2-story SFR w/garage				2004
New	Approved Basic #01-100636 BP		Plan: GSC Duplex 1	Rambler Style Duplex - 199	2004
New	Approved Basic #01-100636 BP		Plan: GSC Duplex 1	Rambler Style Duplex - 199	2004
New	Approved Basic #01-100636 BP		Plan: GSC Duplex 1	Rambler Style Duplex - 199	2004
New	Approved Basic #04-109196 BP		Plan: 2535	Two Story SFR - 1997 UBC	2004
New	2 story SFR w/attached garage	1997 UBC	Plan:4020B-C		2004
New	2 story SFR w/attached garage	1997 UBC	Plan:3011B-C-G		2004
New	Two Story SFR - 1997 UBC		Plan: 5022 FB-C		2004
New	2 story SFR w/attached garage	1997 UBC	Plan:4010DB-B		2004
New	2 story SFR w/attached garage	1997 UBC	Plan:5022F-B		2004
New	2 story SFR w/attached garage	1997 UBC	Plan:411-B-LG		2004

Accessory Dwelling Units

Index # - File Name: 1.0022 - Single Family Dwellings Data\_Snohomish County.pdf

New	2 story SFR w/attached garage	1997 UBC	Plan:4008-B	2004
New	2 story SFR w/attached garage	1997 UBC	Plan:5022FB-A	2004
New	Two-story SFRw/attached garage	1997UBC	Plan: 4111-C	2004
New	2 story SFR w/attached garage	1997 UBC	Plan:3111B-C	2004
New	2 story SFR w/attached garage	1997 UBC	Plan:4008-C	2004
New	Two-story SFR - 1997 UBC		Plan: 5022FB-A	2004
New	2 story SFR w/attached garge	1997 UBC	Plan:4010DB-C-LG	2004
New	Two-story SFRw/attached garage	1997UBC	Plan 4008-C-LG	2004
New	Two-story SFR - 1997UBC		Plan 5022F-C-L	2004
New	2 story SFR w/attached garage	1997 UBC	Plan:3010-A	2004
New	2 story SFR w/attached garage	1997 UBC	Plan:3010B	2004
New	Two-story SFRw/attached garage	1997 UBC	Plan: 4008-B	2004
New	2 story SFR w/attached garage	1997 UBC	Plan: 3012B	2004
New	2 story SFR w/finished basement & attached garage	1997 UBC	Plan:6001B	2004
New	2 story SFR w/finished basement & attached garage	1997 UBC	Plan:6003A	2004
New	2 story SFR w/finished basement & attached garage	1997 UBC	Plan:6001A	2004
New	SFR w/finished basement & attached garage	1997 UBC	Plan:6002A	2004
New	2 story SFR w/finished basement & attached garage	1997 UBC	Plan:6003B	2004
New	SFR w/finished basement & attached garage	1997 UBC	Plan:6002B	2004
New	2 story SFRw/attached garage	1997 UBC	Plan:5022BF A-G	2004
New	2 story SFR w/attached garage	1997 UBC	Plan:4010 DB-C	2004
New	2 story SFR w/attached garage	1997 UBC	Plan :4111C-RG	2004
New	2 story SFR w/attached garage	1997 UBC	Plan:5022 F-B	2004
New	2 story SFR w/attached garage	1997 UBC	Plan 4010 D-A-G	2004
New	2 story SFR w/attached garage	2003 IRC	Plan:5022FB-B-R	2004
New	2 story SFR w/attached garage	2003 IRC	Plan:4008-A-RX	2004
New	2 story SFR w/attached garage	2003 IRC	Plan:4010D-C-LXK	2004
New	2 story SFR w/attached garage	2003 IRC	Plan:4008-C-RXK	2004
New	2 story SFR w/attached garage	1997 UBC	Plan:5022FB-A	2004
New	2 story SFR w/attached garage	1997 UBC	Plan:4008A-G	2004
New	2 story SFR w/attached garage	1997 UBC	Plan:4010DB-C	2004
New	2 story SFR w/attached garage	1997 UBC	Plan:4111 B-X	2004
New	2 story SFR w/attached garage	1997 UBC	Plan:3111B	2004
New	2 story SFR w/attached garage	1997 UBC	Plan:5022F-C	2004
New	2 story SFR w/attached garage	1997 UBC	Plan:4010D-A-X	2004
New	2 story SFR w/attached garage	1997 UBC	Plan:4008-B-X	2004
New	2 story SFR w/attached garage	1997 UBC	Plan:4020 B-C-X	2004
New	2 story SFR w/attached garage	1997 UBC	Plan:3012C-X	2004
New	2 story SFR w/attached garage	1997 UBC	Plan:4002B-X	2004
New	2 story SFR w/attached garage	1997 UBC	Plan:4010 D-A-G	2004
New	2 story SFR w/attached garage	1997 UBC	Plan:4111B-G	2004
New	2 story SFR w/attached garage	1997 UBC	Plan:4008A-G	2004
New	2 story SFR w/attached garage	1997 UBC	Plan:5022F-B	2004
New	2 story SFR w/attached garage	2003 IRC	Plan:3010-C-R	2004
New	2 story SFR w/attached garage	2003 IRC	Plan:4020A-LX	2004
New	2 story SFR w/attached garage	2003 IRC	Plan4111-A	2004
New	2 story SFR w/attached garage	2003 IRC	Plan:4111-B-RD	2004

Accessory Dwelling Units

Index # - File Name: 1.0022 - Single Family Dwellings Data\_Snohomish County.pdf

New	2 story SFR w/attached garage	2003 IRC	Plan:4008-C-L	2004
New	2 story SFR w/attached garage	2003 IRC	Plan:4002 B-B-L	2004
New	Two-story SFR with attached 3-car garage -	2003 IRC		2004
New	Two-story SFR with attached 3-car garage -	2003 IRC		2004
New	Two-story SFR with attached 2-car garage -	2003 IRC		2004
New	Two-story SFR with attached 2-car garage -	2003 IRC		2004
New	Two-story SFR with attached 3-car garage -	2003 IRC		2004
New	Two-story SFR with attached 3-car garage -	2003 IRC		2004
New	Two-story SFR with attached 3-car garage -	2003 IRC		2004
New	Two-story SFR with attached 2-car garage -	2003 IRC		2004
New	Approved Basic 04-114578BP	2 story SFR w/attached garage	2003 IRC Plan:2978	2004
New	2 story SFR w/attached garage	1997 UBC	Plan:2473	2004
New	Approved Basic 04-112274BP	2 story SFR w/ attached garage	2003 IRC Plan#2205 A & B	2004
New	Approved Basic 04-111504BP		Plan: 2863-B Two-story SFR - 2003 IRC	2004
New	Approved Basic 04-111508BP		Plan 3387-C Two-story SFR - 2003 IRC	2004
New	Approved Basic 04-114926BP	2 story SFR w/attached garage	2003 IRC Plan 2451A & B	2004
New	Approved Basic 04-111510BP		Plan 3387-A Two-story SFR - 2003 IRC	2004
New	Approved Basic 04-116427BP		Plan: 3512 A & B Two-story SFR with attach	2004
New	Approved Basic 04-116177BP		Builders plan# 2575-A&B 2-Story SFR w/atta	2004
New	Approved Basic 04-116418BP		Plan: 2149 B Two-story SFR with attached garag	2004
New	Approved Basic 04-111506BP		Plan: 2863-C Two-story SFR - 2003 IRC	2004
New	Approved Basic 04-116177BP		Builders plan# 2575-B 2-Story SFR w/attach	2004
New	Approved Basic 04-113874PB	Two Story SFR w/attached 2 Car Garage	2003 IRC Builder	2004
New	Approved Basic 04-111511BP		Plan 3387-B Two-story SFR - 2003 IRC	2004
New	2 story w/unfin basememnt, 1 car garage & Carport/Portico			2004
New	Approved Basic 04-116427BP		Plan: 3512 A & B Two-story SFR with attach	2004
New	Approved Basic 04-111504BP		Plan: 2863-B Two-story SFR - 2003 IRC	2004
New	Approved Basic 04-116427BP		Plan: 3512 A & B Two-story SFR with attach	2004
New	Approved Basic 04-111511BP		Plan 3387-B Two-story SFR - 2003 IRC	2004
New	Approved Basic 04-113874BP	Two Story SFR with Attached 2 Car Garage	2003 IRC	2004
New	Approved Basic 04-111510BP		Plan 3387-A Two-story SFR - 2003 IRC	2004
New	Approved Basic 04-112274BP	2 story SFR w/ attached garage	2003 IRC Plan#2205 A & B	2004
New	Approved Basic 04-111511BP		Plan 3387-B Two-story SFR - 2003 IRC	2004
New	Approved Basic 04-114264BP		Plan: 3192A Two-story SFR - 2003 IRC	2004
New	Approved Basic 04-116177BP		Builders plan# 2575-A&B 2-Story SFR w/atta	2004
New	Approved Basic 04-116427BP		Plan: 3512 A & B Two-story SFR with attach	2004
New	Approved Basic 04-112274BP	2 story SFR w/ attached garage	2003 IRC Plan#2205 A & B	2004
New	Approved Basic 04-115241BP		Plan: 2473 Two-story SFR - 2003 IRC	2004
New	Approved Basic 04-118514BP	2 story SFR w/attached garage	2003 IRC Plan:2068	2004
New	Approved Basic 04-115238BP		Plan: 2201T/2 Two-story SFR - 2003 I	2004
New	2 story SFR w/attached garage	1997 UBC	Plan:2473	2004
New	Approved Basic 04-114578BP	2 story SFR w/attached garage	2003 IRC Plan:2978	2004
New	Approved Basic 04-115238BP		Plan: 2201 Two-story SFR - 2003 IRC	2004
New	Approved Basic 04-114578BP	2 story SFR w/attached garage	2003 IRC Plan:2978	2004
New	Approved Basic 04-115241BP		Plan: 2473 Two-story SFR - 2003 IRC	2004
New	Approved Basic 04-118514BP	2 story SFR w/attached garage	2003 IRC Plan:2068	2004
New	Approved Basic 04-115241BP		Plan: 2473 Two-story SFR - 2003 IRC	2004



Accessory Dwelling Units

Index # - File Name: 1.0022 - Single Family Dwellings Data\_Snohomish County.pdf

New	Approved Basic 04-114578BP	2 story SFR w/attached garage	2003 IRC	Plan:2978	2004
New	Approved Basic 04-117671BP	2 story SFR w/attached garage	2003 IRC	Plan:2153	2004
New	Approved Basic 04-118514BP	2 story SFR w/attached garage	2003 IRC	Plan:2068	2004
New	Approved Basic 04-114574BP	2 story SFRw/attached garage	2003 IRC	Plan:1861	2004
New	Approved Basic 04-112274BP	2 story SFR w/ attached garage	2003 IRC	Plan#2205 A & B	2004
New	Approved Basic 04-113874PB	Two Story SFR w/attached 2 Car Garage	2003 IRC	Builder	2004
New	Approved Basic 04-111504BP		Plan: 2863-B	Two-story SFR - 2003 IRC	2004
New	Approved Basic 04-114926BP	2 story SFR w/attached garage	2003 IRC	Plan 2451A & B	2004
New	Approved Basic 04-111504BP		Plan: 2863-B	Two-story SFR - 2003 IRC	2004
New	Approved Basic 04-115241BP		Plan: 2473	Two-story SFR - 2003 IRC	2004
New	Approved Basic 04-117671BP	2 story SFR w/attached garage	2003 IRC	Plan:2153	2004
New	Approved Basic 04-115238BP		Plan: 2201	Two-story SFR - 2003 IRC	2004
New	Approved Basic 04-117671BP	2 story SFR w/attached garage	2003 IRC	Plan:2153	2004
New	Approved Basic 04-115241BP		Plan: 2473	Two-story SFR - 2003 IRC	2004
New	Approved Basic 04-114578BP	2 story SFR w/attached garage	2003 IRC	Plan:2978	2004
New	Approved Basic 04-118514BP	2 story SFR w/attached garage	2003 IRC	Plan:2068	2004
New	Approved Basic 04-115238BP		Plan: 2201	Two-story SFR - 2003 IRC	2004
New	Approved Basic #04-109587 BP		Builders Plan 2-2066	Two Story SFR - 1997 UB	2004
New	Approved Basic 04 110492 BP			Rambler Style SFR w/attac	2004
New	Approved Basic 04-111510BP		Plan 3387-A	Two-story SFR - 2003 IRC	2004
New	Approved Basic 04-111506BP		Plan: 2863-C	Two-story SFR - 2003 IRC	2004
New	Approved Basic 04-113874PB	Two Story SFR w/attached 2 Car Garage	2003 IRC	Builder	2004
New	Approved Basic 04-111504BP		Plan: 2863-B	Two-story SFR - 2003 IRC	2004
New	Approved Basic 04-114264BP		Plan: 3192A	Two-story SFR - 2003 IRC	2004
New	Approved Basic 04-116177BP		Builders plan# 2575-A&B	2-Story SFR w/atta	2004
New	2 story SFR w/attached garage	2003 IRC	Plan:4010D-C-G		2004
New	27 x 60 - 2004 Oakwood Mobile Home.				2004
New	2 story w/garage - 2003 IRC	Bldrs plan number M2222A3S-10			2004
New	Approved Basic #02-107345 BP		Plan: 2461	Two Story SFR - 1997 UBC	2004
New	2 story SFR w/attached garage	2003 IRC			2004
New	2-story w/garage				2004
New	Approved Basic #02-107345 BP		Plan: 2461	Two Story SFR - 1997 UBC	2004
New	Approved basic 01-106492BP	Plan 2590	Two Story SFR - 1997 UBC		2004
New	2 story SFR w/attached garage	1997 UBC	Plan:#2415		2004
New	2 story SFR w/attached garage	1997 UBC	Plan:#2400		2004
New	2 story SFR w/attached garage	1997 UBC	Plan:#2415		2004
New	2 story SFR w/attached garage	1997 UBC	Plan:#2490		2004
New	2 story SFR w/attached garage	1997 UBC	Plan:#2490		2004
New	2 story SFR w/attached garage	1997 UBC	Plan:#2490		2004
New	2 story SFR w/attached garage	1997 UBC	Plan:#2415		2004
New	2 story SFR w/attached garage	1997 UBC	Plan:#2400		2004
New	2 story SFR w/attached garage	1997 UBC	Plan:#2415		2004
New	2 story SFR w/attached garage	2003 IRC			2004
New	2-story w/attached garage	2003 IRC			2004
New	2 story SFR w/attached garage	2003 IRC	Plan: M2490B3F-0		2004
New	2 Story w/ Attached 2 Car Garage and unfinished 2nd floor storage areas above garage and part				2004
New	Approved Basic #01-107405 BP		Plan: 1446	Rambler Style SFR - 1997 UBC	2004

Accessory Dwelling Units

Index # - File Name: 1.0022 - Single Family Dwellings Data\_Snohomish County.pdf

New	Approved Basic #01-107405 BP	Plan: 1446 Rambler Style SFR - 1997 UBC	2004
New	Approved Basic #03-104635 BP	Plan: 2222 Two-story SFR - 1997 UBC	2004
New	Approved Basic #01-107401BP	Plan: 1520 Rambler Style SFR - 1997 UBC	2004
New	Approved Basic #01-107405 BP	Plan: 1446 Rambler Style SFR - 1997 UBC	2004
New	Approved Basic #01-107401BP	Plan: 1520 Rambler Style SFR - 1997 UBC	2004
New	Approved Basic #01-107405 BP	Plan: 1446 Rambler Style SFR - 1997 UBC	2004
New	Approved Basic #01-107401BP	Plan: 1520 Rambler Style SFR - 1997 UBC	2004
New	Approved Basic #01-107401BP	Plan: 1520 Rambler Style SFR - 1997 UBC	2004
New	Approved Basic #01-107405 BP	Plan: 1446 Rambler Style SFR - 1997 UBC	2004
New	Approved Basic #01-107401BP	Plan: 1520 Rambler Style SFR - 1997 UBC	2004
New	Approved Basic #01-107401BP	Plan: 1520 Rambler Style SFR - 1997 UBC	2004
New	Approved Basic #01-107401BP	Plan: 1520 Rambler Style SFR - 1997 UBC	2004
New	Approved Basic #01-107401BP	Plan: 1520 Rambler Style SFR - 1997 UBC	2004
New	Approved Basic #01-107405 BP	Plan: 1446 Rambler Style SFR - 1997 UBC	2004
New	Approved Basic #01-107401BP	Plan: 1520 Rambler Style SFR - 1997 UBC	2004
New	Approved Basic #01-107405BP	Plan: 1446 Rambler Style SFR - 1997 UBC	2004
New	Approved Basic 04-111502BP	Plan 2863-A Two-story SFR - 2003 IR	2004
New	Approved Basic 04-114926BP	2 story SFR w/attached garage 2003 IRC Plan 2451A & B	2004
New	Approved Basic 04-114264BP	Plan: 3192A Two-story SFR - 2003 IRC	2004
New	Approved Basic 04-111506BP	Plan: 2863-C Two-story SFR - 2003 IRC	2004
New	Approved Basic 04-116418BP	Plan: 2149 A & B Two-story SFR with attached g	2004
New	Approved Basic 04-111502BP	Plan 2863-A Two-story SFR - 2003 IR	2004
New	Approved Basic 04-114926BP	2 story SFR w/attached garage 2003 IRC Plan 2451A & B	2004
New	Approved Basic 04-116418BP	Plan: 2149 A & B Two-story SFR with attached g	2004
New	Approved Basic 04-114926 BP	2 story SFR w/attached garage 2003 IRC Plan 2451A & B	2004
New	Approved Basic 04-116418BP	Plan: 2149 A & B Two-story SFR with attached g	2004
New	Approved Basic 04-116418BP	Plan: 2149 A & B Two-story SFR with attached g	2004
New	Approved Basic 04-116418BP	Plan: 2149 A & B Two-story SFR with attached g	2004
New	Approved Basic 04-115137BP	2 story SFR w/attached garage 2003 IRC Plan:50070-A3T	2004
New	Approved Basic 04-115845BP	2 story SFR w/attached garage 2003 IRC Plan:70010-A4T	2004
New	Approved Basic 04-115845BP	2 story SFR w/attached garage 2003 IRC Plan:70010-A4T	2004
New	Approved Basic 04-115852BP	2 story SFR w/attached garage 2003 IRC Plan:65010-A3	2004
New	Approved Basic 04-115849BP	2 story SFR w/attached garage 2003 IRC Plan:40030-A3T	2004
New	Approved Basic 04-114427BP	Plan: 50080-A3 Two-story SFR - 2003 IRC	2004
New	Approved Basic 04-114424BP	Plan: 50050-A4T Two-story SFR - 2003 IRC	2004
New	Approved Basic 04-115137BP	2 story SFR w/attached garage 2003 IRC Plan:50070-A3T	2004
New	Approved Basic 04-115134BP	2 story SFR w/attached garage 2003 IRC Plan:50090-A3	2004
New	Approved Basic 04-115134BP	2 story SFR w/attached garage 2003 IRC Plan:50090-A3	2004
New	Approved Basic 04-114800BP	Plan: 40020-A2 Two-story SFR - 2003 IRC	2004
New	Approved Basic 04-114424BP	Plan: 50050-A4T Two-story SFR - 2003 IRC	2004
New	Approved Basic 04-114427BP	Plan: 50080-A3 Two-story SFR - 2003 IRC	2004
New	Approved Basic 04-114800BP	Plan: 40020-A2 Two-story SFR - 2003 IRC	2004
New	Approved Basic 04-115137BP	2 story SFR w/attached garage 2003 IRC Plan:50070-A3T	2004
New	Approved Basic 04-114424BP	Plan: 50050-A4T Two-story SFR - 2003 IRC	2004
New	Approved Basic 04-115137BP	2 story SFR w/attached garage 2003 IRC Plan:50070-A3T	2004
New	Approved Basic 04-114424BP	Plan: 50050-A4T Two-story SFR - 2003 IRC	2004
New	Approved Basic 04-114800BP	Plan: 40020-A2 Two-story SFR - 2003 IRC	2004

Accessory Dwelling Units

Index # - File Name: 1.0022 - Single Family Dwellings Data\_Snohomish County.pdf

New	Approved Basic 04-116489BP	2 story SFR w/attached garage	2003 IRC	Plan:Whitney Hip (I)	2004
New	Approved Basic 04-116494BP	2 story SFR w/attached garage	2003 IRC	Plan:Shasta Gable	2004
New	Approved Basic #02-109686 BP	Plan: Glacier/Gable (A)	Two Story SFR - 1997 UBC		2004
New	Approved Basic 04-116494BP	2 story SFR w/attached garage	2003 IRC	Plan:Shasta Gable	2004
New	Approved Basic 04-116499BP	2 story SFR w/attached garage	2003 IRC	Plan:Tyndall Gable (	2004
New	Approved Basic 04-116494BP	2 story SFR w/attached garage	2003 IRC	Plan:Shasta Gable	2004
New	Approved Basic 04-117066BP	2 story SFR w/attached garage	2003 IRC	Plan:Trinity Gab	2004
New	Approved Basic 04-116501BP	2 story SFR w/attached garage	2003 IRC	Plan:Glacier Gable	2004
New	Approved Basic 04-116505BP	2 sstory SFR w/attached garage	2003 IRC	Plan:Appleton Gabl	2004
New	Approved Basic 04-116508BP	2 story SFR w/attached garage	2003 IRC	Plan:Langley Hip (I)	2004
New	Approved Basic #02-109683 BP	Plan: Shasta/Gable (C)	Two Story SFR - 1997 UBC		2004
New	Approved Basic 04-115973BP	2 sztory SFR w/attached garage	2003 IRC	Plan:4855AB	2004
New	Approved Basic 04-117940BP	2 story SFR w/attached garage	2003 IRC	Plan:755 CM	2004
New	Approved Basic 04-116377BP	2 story SFR w/attached garage	2003 IRC	Plan:5055A	2004
New	Approved Basic #03-108899 BP	Two Story SFR - 1997 UBC			2004
New	Rambler style SFR w/garage				2004
New	Approved Basic #03-100681 BP	Plan: 2195-A	Split Entry SFR - 1997 UBC		2004
New	Approved Basic 04-117940BP	2 story SFR w/attached garage	2003 IRC	Plan:755 CM	2004
New	Approved Basic 04-120673BP	Plan: 5039 AM	Two-story SFR with 3-car/4		2004
New	Approved Basic 04-115973BP	2 sztory SFR w/attached garage	2003 IRC	Plan:4855AB	2004
New	Approved Basic 04-117938BP	2 story SFR w/attached garage	2003 IRC	Plan:F5055A	2004
New	Approved Basic 04-115973BP	2 sztory SFR w/attached garage	2003 IRC	Plan:4855AB	2004
New	Two-story SFR - 1997 UBC	Plan: 5055A			2004
New	Two-story SFR - 1997 UBC	Plan: 5039 M			2004
New	2 story SFR w/attached garage	2003 IRC	Plan:Turnberry		2004
New	2 story SFR w/attached garage	2003 IRC	Plan: Manchester		2004
New	Approved Basic 04-110090BP	2 story sfr w/attached garage	1997 UBC	Plan:Water	2004
New	2 story SFR w/attached garage	2003 IRC	Plan: Manchester B		2004
New	2 story SFR w/attached garage	2003 IRC	Plan:Valhalla B		2004
New	Two-story SFR - 1997 UBC	Plan: 5039 M			2004
New	Approved Basic 04-116377BP	2 story SFR w/attached garage	2003 IRC	Plan:5055A	2004
New	Two-story SFR - 1997 UBC	Plan: 5055A			2004
New	Approved Basic 04-120673BP	Plan: 5039 AM	Two-story SFR with 3-car/4		2004
New	Approved Basic 04-120673BP	Plan: 5039 AM	Two-story SFR with 3-car/4		2004
New	2 story SFR w/attached garage	2003 IRC	Plan:Sammamish		2004
New	2 story SFR w/attached garage	2003 IRC	Plan:Waterford A		2004
New	2 story SFR w/attached garage	2003 IRC	Plan: Turnberry		2004
New	2 story SFR w/attached garage	2003 IRC	Plan: Manchester B		2004
New	2 story SFR w/attached garage	2003 IRC	Plan:Turnberry		2004
New	Approved Basic 04-110090BP	2 story sfr w/attached garage	1997 UBC	Plan:Water	2004
New	2 story SFR w/attached garage	2003 IRC	Plan: Manchester		2004
New	Approved Basic 04-120673BP	Plan: 5039 AM	Two-story SFR with 3-car/4		2004
New	Approved Basic 04-116008BP	2 story SFR w/attached garage	2003 IRC	Plan:2160	2004
New	Approved Basic 04-115720BP	Plan: 3232	Two-story SFR - 2003 IRC		2004
New	Approved Basic 04 -119331 BP	Two-story SFRw/attached garage			2004
New	Approved Basic 04-115715BP	Plan: 2949	Two-story SFR - 2003 IRC		2004
New	Approved Basic 04-115720BP	Plan: 3232	Two-story SFR - 2003 IRC		2004

Accessory Dwelling Units

Index # - File Name: 1.0022 - Single Family Dwellings Data\_Snohomish County.pdf

New	Approved Basic 04-115715BP	Plan: 2949	Two-story SFR - 2003 IRC	2004
New	Approved Basic 04-115710BP	Plan: 2677	Two-story SFR - 2003 IRC	2004
New	Approved Basic 04 -119331 BP		Two-story SFRw/attached garage	2004
New	Approved Basic 04-115715BP	Plan: 2949	Two-story SFR - 2003 IRC	2004
New	Approved Basic 04-115715BP	Plan: 2949	Two-story SFR - 2003 IRC	2004
New	Approved Basic 04 -119331 BP		Two-story SFRw/attached garage	2004
New	Approved Basic 04-115715BP	Plan: 2949	Two-story SFR - 2003 IRC	2004
New	Approved Basic 04-115715BP	Plan: 2949	Two-story SFR - 2003 IRC	2004
New	Approved Basic 04-115715BP	Plan: 2949	Two-story SFR - 2003 IRC	2004
New	Approved Basic 04-115710BP	Plan: 2677	Two-story SFR - 2003 IRC	2004
New	Approved Basic 04-115720BP	Plan: 3232	Two-story SFR - 2003 IRC	2004
New	Approved Basic 04-1125956BP	2 story SFR w/attached garage	2003 IRC Plan:2054	2004
New	2 Story Single Family Residence w/attached garage			2004
New	2 Story Single Family Residence W/garage			2004
New	Approved Basic 04-114805 BP	Plan 50010-A3	Two-story SFR - 2003 IRC	2004
New	Approved Basic 04-114805 BP	Plan 50010-A3	Two-story SFR - 2003 IRC	2004
New	Approved Basic 04-117295BP	2 story SFR w/attached garage	2003 IRC Plan:50030-A2	2004
New	Approved Basic 04-114805 BP	Plan 50010-A3	Two-story SFR - 2003 IRC	2004
New	Approved Basic 04-114805 BP	Plan 50010-A3	Two-story SFR - 2003 IRC	2004
New	Approved Basic 04-117194BP	2 story SFR w/attached garage	2003 IRC Plan:50040-A2	2004
New	Approved Basic 04-117295BP	2 story SFR w/attached garage	2003 IRC Plan:50030-A2	2004
New	Approved Basic 04-116375BP	Plan: 50020	Two-story SFR with attached garage	2004
New	Approved Basic 04-117295BP	2 story SFR w/attached garage	2003 IRC Plan:50030-A2	2004
New	Approved Basic 04-117194BP	2 story SFR w/attached garage	2003 IRC Plan:50040-A2	2004
New	Approved Basic 04-116375BP	Plan: 50020	Two-story SFR with attached garage	2004
New	Approved Basic 04-117194BP	2 story SFR w/attached garage	2003 IRC Plan:50040-A2	2004
New	Approved Basic #03-110650 BP	Plan: Tyndall Gable (A)	Two Story SFR - 1997 UBC	2004
New	Approved Basic 04-116501BP	2 story SFR w/attached garage	2003 IRC Plan:Glacier Gable	2004
New	Approved Basic 04-116501BP	2 story SFR w/attached garage	2003 IRC Plan:Glacier Gable	2004
New	Approved Basic 04-116494BP	2 story SFR w/attached garage	2003 IRC Plan:Shasta Gable	2004
New	Approved Basic 04-117066BP	2 story SFR w/attached garage	2003 IRC Plan:Trinity Gable	2004
New	Approved Basic 04-116501BP	2 story SFR w/attached garage	2003 IRC Plan:Glacier Gable	2004
New	Approved Basic 04-116505BP	2 sstory SFR w/attached garage	2003 IRC Plan:Appleton Gable	2004
New	Approved Basic 04-117066BP	2 story SFR w/attached garage	2003 IRC Plan:Trinity Gable	2004
New	Approved Basic 04-116499BP	2 story SFR w/attached garage	2003 IRC Plan:Tyndall Gable (	2004
New	Approved Basic 04-116699BP	2 story SFR w/attached garage	2003 IRC Plan: Madison Hip	2004
New	Approved Basic 04-116494BP	2 story SFR w/attached garage	2003 IRC Plan:Shasta Gable	2004
New	Approved Basic 04-117034BP	2 story SFR w/attached garage	2003 IRC Plan:2590C	2004
New	Approved Basic 04-117039BP	2 story SFR w/attached garage	2003 IRC Plan:2332	2004
New	Approved Basic 04-117034BP	2 story SFR w/attached garage	2003 IRC Plan:2590C	2004
New	2 story SFR w/attached garage	2003 IRC	Plan:2562	2004
New	Approved Basic 04-117039BP	2 story SFR w/attached garage	2003 IRC Plan:2332	2004
New	Approved Basic 04-117034BP	2 story SFR w/attached garage	2003 IRC Plan:2590C	2004
New	2 story SFR w/attached garage	2003 IRC	Plan:3105-C	2004
New	Two-story SFR with attached 2-car garage -	2003 IRC	Plan: 3012-C	2004
New	2 story SFR w/attached garage	2003 IRC	Plan:4013A	2004
New	2 Story w/attached garage	2003 IRC	Plan:4010 D-C	2004

Accessory Dwelling Units

Index # - File Name: 1.0022 - Single Family Dwellings Data\_Snohomish County.pdf

New	2 - story SFR w/attached garage	2003 IBC	Plan # 5025 L- A	2004
New	Two-story SFR with attached 2-car garage -	2003 IRC	Plan 4010DB-A	2004
New	2 - Story SFR w/attached garage	2003 IBC	Plan 5025 - B	2004
New	2 story SFR w/attached garage	2003 IRC	Plan:3012-A-RX	2004
New	2 story SFR w/attached garage	2003 IRC	Plan:3010-B	2004
New	2 story SFR w/attached garage	2003 IRC	Plan:3011-C	2004
New	2 story SFR w/attached garage	2003 IRC	Plan:3012 C-X	2004
New	2 story SFR w/attached garage	2003 IRC	Plan:311 B-B2	2004
New	2 story SFR w/attached garage	2003 IRC	Plan:3012 B-RX	2004
New	2 story SFR w/attached garage	2003 IRC	Plan:311-C-L	2004
New	2 story SFR w/attached garage	2003 IRC	Plan:3010-C-RX	2004
New	2 story SFR w/attached garage	2003 IRC	Plan:3012-A-L	2004
New	2 story SFR w/attached garage	2003 IRC	Plan:3011-B-R	2004
New	2 story SFR w/attached garage	2003 IRC	Plan:3010-B-R	2004
New	2 - Story SFR w/attached garage	2003 IBC	Plan # 3105 - C	2004
New	Two-story SFR with attached 2-car garage -	2003 IRC	Plan: 4012-A	2004
New	2 - Story SFR w/attached garage	2003 IBC	Plan: 3006 - C	2004
New	2 story SFR w/attached garage	2003 IRC	Plan:4013B-C-R	2004
New	2 story SFR w/attached garage	2003 IRC	Plan:3006-B	2004
New	2 story SFR w/attached garage	2003 IRC	Plan:4012B-B	2004
New	2 story SFR w/attached garage	2003 IRC	Plan:3012-B	2004
New	2 story SFR w/attached garage	2003 IRC	Plan:5025-A	2004
New	Approved Basic 04-115715BP		Plan: 2949 Two-story SFR - 2003 IRC	2004
New	Approved Basic 04-115960BP	2 story SFR w/attached garage	2003 IRC Plan:2289	2004
New	2 - Story SFR w/attached garage	2003 IRC	Plan: 3012 - C	2004
New	2 story SFR w/attached garage	2003 IRC	Plan: Valhalla	2004
New	2 story SFR w/attached garage	2003 IRC	Plan:3010-B	2004
New	2 story SFR w/attached garage	2003 IRC	Plan:3111-B	2004
New	28 x 56 - 2002 Redmond Mobile Home			2004
New	Single family residence with finished basement & attached garage -	2003 IRC		2004
New	SFR with 573 sq ft Second Floor and Attached Garage			2004
New	Approved Basic 04-119788BP		Plan 2184 Quad level SFR with semi-fini:	2004
New	Approved Basic 04-117114BP		Plan: 1538 Rambler with attached garage - 20	2004
New	Approved Basic # 04-116650BP		Plan:2360 Two Story SFR with Att	2004
New	Approved Basic 04-117114BP		Plan: 1538 Rambler with attached garage - 20	2004
New	Approved Basic 04-119145BP		Plan 1786 Two-story SFR with attached	2004
New	Approved Basic 04-116655BP		Plan :1864 Rambler with Attached Gara	2004
New	Approved Basic # 04-116650BP		Plan 2360 Two Story SFR with Att	2004
New	Single story SFR with attached garage			2004
New	Approved Basic #04-116770 BP		Plan:2119 2-story w/garage	2004
New	Approved Basic #04-116771 BP	2-story w/attached garage	2003 IRC Plan:2117	2004
New	Approved Basic 04-116655BP		Plan:1864 Rambler with Attached Gara	2004
New	Approved Basic #04-116770 BP		Plan:2119 2-story w/attached garage	2004
New	Approved Basic 04-119788BP		Plan 2184 Quad level SFR with semi-fini:	2004
New	Approved Basic 04-119788BP		Plan 2184 Quad level SFR with semi-fini:	2004
New	Approved Basic #04-116771 BP	2-story w/attached garage	2003 IRC Plan:2117	2004
New	Approved Basic # 04-116650BP		Plan:2360 Two Story SFR with Att	2004

Accessory Dwelling Units

Index # - File Name: 1.0022 - Single Family Dwellings Data\_Snohomish County.pdf

New	Approved Basic 04-117111BP	Plan: 2471	Two-story SFR with attached ga	2004
New	Approved Basic 04-119145BP	Plan 1786	Two-story SFR with attached	2004
New	Two Story SFR with Attached Garage	2003 IRC		2004
New	Two Story SFR with Attached Garage	2003 IRC		2004
New	Two story sfr w/attached garage	2003 IRC	Plan:Harrington III	2004
New	Two story SFR with attached garage	2003 IRC	Plan :Willow II	2004
New	2 story single family w 3 car garage			2004
New	2-story SFR w/attached garage	2003 IRC	Plan	2004
New	Approved Basic 04-117111BP	Plan: 2471	Two-story SFR with attached ga	2004
New	2 story single family with basement and 2 car garage			2004
New	Two story sfr w/attached garage	2003 IRC	Plan:Harrington III	2004
New	Two story SFR with attached garage	2003 IRC	Plan:Pomeroy	2004
New	Approved Basic 04-115047BP	1 story SFR w/attached garage	2003 IRC Plan:Eagle 2	2004
New	Approved Basic 04-111634BP	Plan: 3420-D	Two-story Duplex - 1997UBC	2004
New	Approved Basic 04-111634BP	Plan: 3420-D	Two-story Duplex - 1997UBC	2004
New	2 story SFR w/attached garage	2003 IRC	Plan:Aldarra	2004
New	Two story SFR with attached garage			2004
New	2 story SFR w/attached garage	2003 IRC	Plan:1734	2004
New	2 Story SFR w/attached garage	2003 IRC	Plan:1819	2004
New	2 Story SFR w/attached garage	2003 IRC	Plan:2381	2004
New	2 story SFR w/attached garage	2003 IRC	Plan:2381	2004
New	2 Story SFR w/attached garage	2003 IRC	Plan:1734	2004
New	2 story SFR w/attached garage	2003 IRC	Plan:1734	2004
New	2 story SFR w/attached garage	2003 IRC	Plan:1819	2004
New	2 story SFR w/attached garage	2003 IRC	Plan:2381	2004
New	2 story SFR w/attached garage	2003 IRC	Plan:1819	2004
New	Two Story SFR - 1997 UBC			2004
New	Two story SFR with attached garage			2004
New	Rambler style w/garage			2004
New	Rambler style SFR w/garage			2004
New	Approved Basic 04-116585BP	2 story SFR w/attached garage	2003 IRC Plan:2590A2F-11	2004
New	Approved Basic 04-119037BP	1 story SFR w/attached garage	2003 IRC Plan:2095	2004
New	Approved Basic 04-119583BP	2 story SFR w/attached garage	2003 IRC Plan:2311	2004
New	Approved Basic #04-119009BP		Shuksan - 3 Car Two Story SFI	2004
New	Approved Basic #04- 119005BP		Shuksan - 2 Car Two Story	2004
New	Approved Basic #04-119004BP		Mt Baker - 3 Car Two Story SFR with l	2004
New	Approved Basic #04-119004BP		Mt Baker - 3 Car Two Story SFR with l	2004
New	Approved Basic #04- 119005BP		Shuksan - 2 Car Two Story SFR with Finishe	2004
New	Approved Basic 04-116584BP	2 story SFR w/attached garage	2003 IRC Plan:2338A3FT-:	2004
New	Approved Basic 04-115758BP	Plan: 2922	Two-story SFR - 2003 IRC	2004
New	Approved Basic 04- 118786BP	Plan: 2690	Two-story SFR with attached 3-c;	2004
New	Approved Basic 04-119801BP	Builders Plan #2488-B	2-Story SFR w/attached gar	2004
New	Approved Basic 04-119803BP	Builders Plan #2509-B	2-Story SFR w/attached garage	2004
New	Approved Basic 04- 119008BP	Plan: 2488	Two-story SFR with attached 2-	2004
New	Approved Basic 04-119006BP	Plan: 2509	Two-story SFR with attached	2004
New	Approved Basic 04-119006BP	Plan: 2509	Two-story SFR with attached	2004
New	Approved Basic 04-116301BP	2 story SFR w/attached garage	2003 IRC Plan:2590	2004

Accessory Dwelling Units

Index # - File Name: 1.0022 - Single Family Dwellings Data\_Snohomish County.pdf

New	Approved Basic 04-116301BP	2 story SFR w/attached garage	2003 IRC	Plan:2590	2004	
New	Approved Basic 04-119011BP			Plan: 2423	Two-story SFR with attached 2-ca	2004
New		2 story single family residence with 3 car garage				2004
New	Approved Basic 04-115758BP			Plan: 2922	Two-story SFR - 2003 IRC	2004
New	Approved Basic 04-119006BP			Plan: 2509	Two-story SFR with attached	2004
New	Approved Basic 04-119802BP	Builders Plan #2423			2-Story SFR w/attached garage	2004
New	Approved Basic #04-115976BP				Rambler with Attached Garage	2004
New		2-Story SFR w/attached garage.	FYI contractor may change			2004
New	Approved 04-117094BP			Plan: 2125B	Two-story SFR with attached garage	2004
New	Approved Basic 04-117090BP			Plan: 2104A	Two-story SFR with attached ga	2004
New	Approved Basic 04-117095BP			Plan: 2295A	Two-story SFR with attached gara	2004
New	Approved Basic 04-117093BP			Plan: 2125A	Two-story SFR with attached gi	2004
New	Approved Basic 04-117095BP			Plan: 2295A	Two-story SFR with attached gara	2004
New	Approved Basic 04-117090BP			Plan: 2104A	Two-story SFR with attached ga	2004
New	Approved Basic 04-117265BP			Plan: 2295B	Two-story SFR with attached ga	2004
New	Approved Basic 04-117091BP			Plan: 2104B	Two-story SFR with attached ga	2004
New	Approved Basic 04-117095BP			Plan: 2295A	Two-story SFR with attached gara	2004
New	Approved 04-117094BP			Plan: 2125B	Two-story SFR with attached garage	2004
New	Approved Basic 04-117093BP			Plan: 2125A	Two-story SFR with attached gi	2004
New	Approved Basic 04-117091BP			Plan: 2104B	Two-story SFR with attached ga	2004
New	Approved Basic 04-117265BP			Plan: 2295B	Two-story SFR with attached ga	2004
New	Approved Basic 04-117090BP			Plan: 2104A	Two-story SFR with attached ga	2004
New	Approved Basic 04-117095BP			Plan: 2295A	Two-story SFR with attached gara	2004
New	Approved Basic 04-117093BP			Plan: 2125A	Two-story SFR with attached gi	2004
New	Approved Basic 04-117091BP			Plan: 2104B	Two-story SFR with attached ga	2004
New	Approved Basic 04-117265BP			Plan: 2295B	Two-story SFR with attached ga	2004
New	Approved Basic 04-120496	split plan w/attached garage	2003 IRC	Plan:2000S		2004
New	Approved Basic 04-117095BP			Plan: 2295A	Two-story SFR with attached gara	2004
New	Approved Basic 04-117091BP			Plan: 2104B	Two-story SFR with attached ga	2004
New	Approved Basic 04-120496BP	split plan w/attached garage	2003 IRC	Plan:2000'		2004
New	Approved Basic 04-120495BP	cal - split plan	2003 IRC	Plan:1800C		2004
New	Approved Basic 04-117093BP			Plan: 2125A	Two-story SFR with attached gi	2004
New	Approved 04-117094BP			Plan: 2125B	Two-story SFR with attached garage	2004
New	Approved Basic 04-117095BP			Plan: 2295A	Two-story SFR with attached gara	2004
New	Approved Basic 04-117090BP			Plan: 2104A	Two-story SFR with attached ga	2004
New	Approved Basic 04-117265BP			Plan: 2295B	Two-story SFR with attached ga	2004
New	Approved Basic 04-117093BP			Plan: 2125A	Two-story SFR with attached gi	2004
New	Approved Basic 04-117091BP			Plan: 2104B	Two-story SFR with attached ga	2004
New	Approved Basic 04-117093BP			Plan: 2125A	Two-story SFR with attached gi	2004
New	Approved Basic 04-117095BP			Plan: 2295A	Two-story SFR with attached gara	2004
New	Approved Basic 04-117090BP			Plan: 2104A	Two-story SFR with attached ga	2004
New	Approved Basic 04-117095BP			Plan: 2295A	Two-story SFR with attached gara	2004
New	Approved Basic 04-117091BP			Plan: 2104B	Two-story SFR with attached ga	2004
New		2-Story Duplex over garages.				2004
New	Approved 04-117094BP			Plan: 2125B	Two-story SFR with attached garage	2004
New	Approved Basic 04-120496BP	split plan w/attached garage	2003 IRC	Plan:2000		2004
New	Approved Basic 04-116585BP	2 story SFR w/attached garage	2003 IRC	Plan:2590A2F-11		2004

Accessory Dwelling Units

Index # - File Name: 1.0022 - Single Family Dwellings Data\_Snohomish County.pdf

New	Approved Basic 04-115758BP	Plan: 2922	Two-story SFR - 2003 IRC	2004
New	Approved Basic 04-119583BP	2 story SFR w/attached garage	2003 IRC Plan:2311	2004
New	1 story SFR w/attached garage	2003 IRC	Plan:2522	2004
New	Approved Basic 04-115758BP	Plan: 2922	Two-story SFR - 2003 IRC	2004
New	Approved Basic 04-120834BP	Plan: M2605A350	Two-story SFR with a	2004
New	Approved Basic 04-120563BP	Plan: M2455A3F-0	Two-story SFR with attache	2004
New	Approved Basic 04-111161BP	Plan: 1932	Two-story SFR - 2003 IRC	2004
New	Approved Basic 04-116616BP	2 story SFR w/attached garage	2003 IRC Plan:1841	2004
New	Approved Basic 04-120167BP	2 story SFR w/attached garage	2003 IRC Plan:2597	2004
New	Approved Basic 04-118845BP	2 story SFR w/attached garage	2003 IRC Plan:2294	2004
New	Approved Basic 04-120167BP	2 story SFR w/attached garage	2003 IRC Plan:2597	2004
New	Approved Basic 04-120167BP	2 story SFR w/attached garage	2003 IRC Plan:2597	2004
New	Approved Basic 04-111161BP	Plan: 1932	Two-story SFR - 2003 IRC	2004
New	Approved Basic 04-116994BP	Plan: 2060	Two-story SFR with attached garage	2004
New	Approved Basic 04-118845BP	2 story SFR w/attached garage	2003 IRC Plan:2294	2004
New	Approved Basic 04-120543BP	Plan: M2330C3F0	Two-Story SFR with attache	2004
New	Approved Basic 04-120827BP	Plan: 2241C3F-2	Two-story SFR with attac	2004
New	Approved Basic 04-121229BP	Plan: R2035A3F-O	Rambler Style SFR with a	2004
New	Approved Basic 04-120560BP	Plan: M2415A3F-4	Two-story SFR with atta	2004
New	2 story single family with 2 car garage			2004
New	Rambler with attached garage - 1997 UBC			2004
New	2-Story SFR over daylight-basement garage.			2004
New	Two-story SFR with attached garage - 2003 IRC			2004
New	Approved Basic 04-119058BP	Plan 1930	Two-story SFR with attached 2	2004
New	Approved Basic 04-119058BP	Plan 1930	Two-story SFR with attached 2	2004
New	One-story SFR with finished basement & attached garage - 2003 IRC			2004
New	Two-story SFR with attached 2-car garage - 2003 IRC			2004
New	Approved Basic 04-119058BP	Plan 1930	Two-story SFR with attached 2	2004
New	Two-story SFR with basement Garage/Shop			2004
New	Two story SFR with attached garage			2004
New	2 story SFR w/attached garage	2003 IRC	Plan: 4	2004
New	2 story SFR w/attached garage	2003 IRC	Plan:2786	2004
New	Approved Basic 04-116621BP	2 Story SFR w/attached garage	2003 IRC Plan:1909	2004
New	Approved Basic 04-118845BP	2 story SFR w/attached garage	2003 IRC Plan:2294	2004
New	Two story SFR with attached garage			2004
New	2 story SFR w/attached garage	2003 IRC	Plan: 3	2004
New	2 story SFR w/attached garage	2003 IRC	Plan:Prescott B	2004
New	2 story SFR w/attached garage	2003 IRC	Plan:Presten B	2004
New	2 story SFR w/attached garage	2003 IRC	Plan:4	2004
New	Two story SFR with attached Garage			2004
New	Approved Basic #04- 118330BP	Plan 2846	Rambler with Attached Gara	2004
New	Approved Basic 04-118493BP	Plan: 1757	Two-story SFR with attached 2-car	2004
New	2-Story SFR over unfinished basement w/attached garage.			2004
New	Approved Basic 04-116091BP	Plan: 1300	Rambler with attached garage	2004
New	Approved Basic #04- 118330BP	Plan 2846	Rambler with Attached Gara	2004
New	Approved basic #04-116876 BP	Plan 2268A	Rambler w/attached garage	2004
New	Approved Basic 04-118734BP	2 story SFR w/attached garage	2003 IRC Plan:2763	2004



Accessory Dwelling Units

Index # - File Name: 1.0022 - Single Family Dwellings Data\_Snohomish County.pdf

New	Approved Basic 04-118733BP	2 story SFR w/attached garage	2003 IRC	Plan:3162	2004
New	Approved Basic 04-118732BP	2 story SFR w/attached garage	2003 IRC	Plan: 2896	2004
New	Approved Basic 04-118734BP	2 story SFR w/attached garage	2003 IRC	Plan:2763	2004
New	Approved Basic 04-118735BP	2 story SFR w/attached garage	2003 IRC	Plan:2830	2004
New	Approved Basic 04-120092BP	2 story SFR w/attached garage	2003 IRC	Plan:2842-A	2004
New	Approved Basic 04-120086BP	2 story SFR w/attached garage	2003 IRC	Plan:3000-B	2004
New	Approved Basic 04-120084BP	2 story SFR w/attached garage	2003 IRC	Plan:3000A	2004
New	Approved Basic 04-120092BP	2 story SFR w/attached garage	2003 IRC	Plan:2842-A	2004
New	New 2-story SFR w/garage				2004
New	Approved Basic 04-118732BP	2 story SFR w/attached garage	2003 IRC	Plan: 2896	2004
New	Approved Basic 04-120087BP	2 story SFR w/attached garage	2003 IRC	Plan:2996-B	2004
New	Approved Basic 04-120085BP	2 story SFR w/attached garage	2003 IRC	Plan:3271-B	2004
New	2-story SFR w/garage				2004
New	Two-story SFR with attached 3-car garage - 2003 IRC		Plan: 2698		2004
New	Two Story SFR with Attached Garage		San Juan		2004
New	Two-story SFR with attached 3-car garage - 2003 IRC		Plan: 2930		2004
New	2-story SFR w/garage				2004
New	Approved Basic 04-116919BP	SFR w/semifinished basement & attached garage	2003 IRC	Pla	2004
New	Approved Basic 04-116915BP	SFR w/semifinished basement w/attached garage	2003 IRC		2004
New	Approved Basic 04-116920BP	SFR w/semifinished basement & attached garage	2003 IRC	Pli	2004
New	Approved Basic 04-116920BP	SFR w/semifinished basement & attached garage	2003 IRC	Pli	2004
New	Approved Basic 04-116915BP	SFR w/semifinished basement w/attached garage	2003 IRC		2004
New	Approved Basic 04-116917BP	SFR w/semifinished basement & attached garage	2003 IRC	Pl	2004
New	Approved Basic 04-116922BP	SFR w/semifinished basement & attached garage	2003 IRC	Pli	2004
New	Approved Basic 04-116920BP	SFR w/semifinished basement & attached garage	2003 IRC	Pli	2004
New	Approved Basic 04-116915BP	SFR w/semifinished basement w/attached garage	2003 IRC		2004
New	Approved Basic 04-120450BP	2 Story SFR w/attached garage	2003 IRC	Plan:30030-A3T	2004
New	Approved Basic 04-120446BP	2 story SFR w/attached garage	2003 IRC	Plan:50040-A3T	2004
New	Approved Basic 04-117295BP	2 story SFR w/attached garage	2003 IRC	Plan:50030-A2	2004
New	Approved Basic 04-114805 BP	Plan 50010-A3 Two-story SFR - 2003 IRC			2004
New	Approved Basic 04-114805 BP	Plan 50010-A3 Two-story SFR - 2003 IRC			2004
New	Approved Basic 04-120450BP	2 Story SFR w/attached garage	2003 IRC	Plan:50030-A3T	2004
New	Two-story SFR - 1997 UBC		Builder s Plan:5055A		2004
New	Approved Basic 04-117194BP	2 story SFR w/attached garage	2003 IRC	Plan:50040-A2	2004
New	Approved Basic 04-117295BP	2 story SFR w/attached garage	2003 IRC	Plan:50030-A2	2004
New	Approved Basic 04-114805 BP	Plan 50010-A3 Two-story SFR - 2003 IRC			2004
New	Approved Basic 04-120446BP	2 story SFR w/attached garage	2003 IRC	Plan:50040-A3T	2004
New	Approved Basic 04-120446BP	2 story SFR w/attached garage	2003 IRC	Plan:50040-A3T	2004
New	2-Story SFR w/attached garage.				2004
New	Approved Basic 04-116374BP	2 story SFR w/attached garage	2003 IRC	Plan:5055A	2004
New	Approved Basic 04-117108BP	Plan: 5038 AM Two-story SFR with attached ga			2004
New	Approved Basic 04-120673BP	Plan: 5039 AM Two-story SFR with 3-car/			2004
New	Approved Basic 04-118453BP	2 story w/attached garage	2003 IRC	Plan:5050A	2004
New	Approved Basic 04-117108BP	Plan: 5038 AM Two-story SFR with attached ga			2004
New	Approved Basic 04-117108BP	Plan: 5038 AM Two-story SFR with attached ga			2004
New	Approved Basic 04-117574BP	Plan: 5060A Two-story SFR with attached gar			2004
New	Approved Basic 04-120673BP	Plan: 5039 AM Two-story SFR with 3-car/			2004

Accessory Dwelling Units

Index # - File Name: 1.0022 - Single Family Dwellings Data\_Snohomish County.pdf

New	Approved Basic 04-118454BP	2 story SFR w/attached garage	2003 IRC	Plan:4855AB	2004
New	Approved Basic 04-117574BP		Plan: 5060A	Two-story SFR with attached gar	2004
New	Approved Basic 04-118454BP	2 story SFR w/attached garage	2003 IRC	Plan:4855AB	2004
New	Approved Basic 04-119423BP		Plan: 2868	Two-story SFR with attach	2004
New	Approved Basic 04-119421BP		Plan: 2740	Two-story SFR with attached	2004
New	Approved Basic 04-119421BP		Plan: 2740	Two-story SFR with attached	2004
New	Approved Basic 04-119637BP		Plan: 2716	Two-story SFR with attached 3-	2004
New	Approved Basic 04-119423BP		Plan: 2868	Two-story SFR with attach	2004
New	Approved Basic 04-120673BP		Plan: 5039 AM	Two-story SFR with 3-car/4	2004
New	Approved Basic 04-116374BP	2 story SFR w/attached garage	2003 IRC	Plan:5055A	2004
New		2 story single family with unfinished basement and 3 car garage			2004
New	Approved Basic 04-120662BP		Plan: 1677	Two-story SFR with attached 3	2004
New	Approved Basic 04-120662BP		Plan: 1677	Two-story SFR with attached 3	2004
New	Approved Basic 04-120662BP		Plan: 1677	Two-story SFR with attached 3	2004
New	Approved Basic 04-120662BP		Plan: 1677	Two-story SFR with attached 3	2004
New		Two-story SFR with attached garage - 2003 IRC			2004
New		2 story SFR w/unfinished basement & attached garage	1997 UBC		2004
New		2 Story SFR with attached garage			2004
New		Two-story SFR w/Attached Accessory Apartment - 1997 UBC			2004
New		2 story SFR w/attached garage	1997 UBC		2004
New		2 Story SFR with attached garage and covered porch			2004
New		Two story SFR with attached 3 car garage			2004
New		2-story sfr			2004
New		2 Story SFR-1997 UBC			2004
New		2 story single family			2004
New		One-story SFR			2004
New		Rambler-style SFR with attached garage - 2003 IRC			2004
New		2145sf rambler with attached garage - 2003 IRC			2004
New		Rambler Style SFR w/attached garage.			2004
New		SFR rambler w/garage			2004
New		SFR Rambler with 4-car garage			2004
New	Approved Basic #03-106139 BP		Plan: 3579	Two Story SFR - 1997 UBC	2004
New		2-Story SFR w/attached garage.			2004
New		NO INSPECTIONS UNTIL GRADING/DRAINAGE REVIEW AND RESTORATION APPROVED 04/28/20			2004
New		2-story w/ garage and unfinished basement			2004
New		Two story SFR with attached garage & 448 sq ft deck			2004
New		480 sf Attic conversion to heated living area in SFR under construction	1997 UBC		2004
New		27x66, 2004 Oakwood			2004
New	Approved Basic #03-103164 BP		Plan: 20084	Rambler Style SFR - 1997 UBC	2004
New		One-story SFR w/semi-finished basement - 1997 UBC			2004
New		2 Story SFR w/ 3 Car			2004
New		One-story SFR - 1997 UBC			2004
New	Approved Basic #03-108705 BP		Plan #2009	Two Story SFR - 1997 UBC	2004
New		28 x 66 - 2003 - Karsten			2004
New		27x52 2004 Golden West Manufactured Home--01-52LF			2004
New		Detached Accessory Apartment			2004
New	Approved Basic #03-102794 BP		Plan: 1966 - revised	Rambler Style SFR - 1997 UE	2004

Accessory Dwelling Units

Index # - File Name: 1.0022 - Single Family Dwellings Data\_Snohomish County.pdf

New	Two-story SFR - 1997 UBC			2004
New	Rambler Style SFR - 1997 UBC. See 04-115318 for inspections done prior to July 31, 2004. (04-1			2004
New	SFR w/2nd floor loft			2004
New	Two-story SFR with attached garage - 2003 IRC			2004
New	Two story SFR - 1997 UBC			2004
New	2-story w/garage			2004
New	Duplex with attached garage --- 1997 UBC			2004
New	Rambler style w/basement - 1997 UBC	Plan: 2274		2004
New	Duplex with attached garage --- 1997 UBC			2004
New	2-story SFR			2004
New	2-Story SFR w/attached garage.			2004
New	Rambler w/ 2 Car			2004
New	Rambler style SFR + attached garage w/storage on 2-nd floor.			2004
New	841 Sq Ft Main Wing SFR - Building B	2003 IRC		2004
New	REVERSED EXPIRED STATUS TO FINAL PER INSPECTION CARD RECEIVED FROM LESLIE RUITER ON			2004
New	2 Story w/ 2 Car & Covered Porch			2004
New	Approved Basic #98-150633BP	Plan: 2555	Two Story SFR - 1997 UBC	2004
New	Approved Basic #01-111494 BP	Bldr Plan SSI 2792	Two-story style SFR....1997 UBC	2004
New	Approved Basic #01-107342 BP	Plan: 2620 SSI	Two Story SFR - 1997 UBC	2004
New	Approved Basic #01-111494 BP	Bldr Plan SSI 2792	Two-story style SFR....1997 UBC	2004
New	Two-story SFR - 1997 UBC			2004
New	Two-story SFR - 1997 UBC			2004
New	Rambler w/basement & garage			2004
New	Two-story SFR w/semi-finished basement - 1997 UBC			2004
New	Rambler Style - 1997 UBC	Plan: 2200	Rambler	2004
New	Rambler with Attached Accessory Apartment			2004
New	Approved Basic #02-102061 BP	Plan: 2010 Rambler	Rambler Style SFR - 1997 UBC	2004
New	Two-story SFR			2004
New	2 story sfr w/finished basement & attached garage	1997 UBC	Plan:2208	2004
New	Rambler with Attached Garage			2004
New	Apporved Basic 04-110978BP	2 story sfr w/attached garage	1997 UBC	Plan:2582A
New	Approved Basic 04-117597BP	2 story SFR w/attached garage	2003 IRC	Plan:3575
New	2 story SFR w/attached garage	2003 IRC	Plan:M3450A3S-2	2004
New	Two Story SFR			2004
New	Rambler with Attached Garage with Second Floor Unheated Storage			2004
New	One-story SFR w/semi-finished basement - 1997 UBC			2004
New	2-story SFR w/garage			2004
New	Approved Basic #02-110422BP	Plan 2500	Rambler-style SFR - 1997 UBC	2004
New	Approved Basic #02-110429 BP	Plan 2600	Tri-Level Tri-Level SFR - 1997 UBC	2004
New	Two story SFR w/ attached garage - 1997 UBC			2004
New	Rambler style w/garage			2004
New	Rambler style w/garage			2004
New	Two Story SFR with Attached Garage	1997 UBC		2004
New	Pending Basic 04 112074 BP	Builder s Plan 2304	2-Story Two-story SFR -	2004
New	See Permit # 06-133820	2 Story SFR w/ deck		2004
New	2 Story SFR with unfinished basement			2004
New	Two-story SFR - 1997 UBC			2004

Accessory Dwelling Units

Index # - File Name: 1.0022 - Single Family Dwellings Data\_Snohomish County.pdf

New	2-story SFR		2004
New	2-story SFR w/garage		2004
New	26 8 X 64 Marlette Pacifica in Park		2004
New	2-Story SFR w/attached basement garage.		2004
New	2022sf rambler - 1997 UBC		2004
New	Rambler Style SFR		2004
New	One-story SFR		2004
New	Rambler style w/garage		2004
New	2 Story SFR with unfinished basement and attached garage		2004
New	Rambler w/attached garage 1997 UBC		2004
New	52 x 28 - 2004 Marlette Lakecrest Mobile Home		2004
New	40x69, 2004 Desert Manor		2004
New	Two Story SFR - 1997 UBC		2004
New	Rambler Style SFR - 1997 UBC		2004
New	2-story SFR w/garage		2004
New	Two Story SFR- 1997UBC		2004
New	Two-story SFR with attached garage - 2003 IRC		2004
New	Rambler with attached garage - 2003 IRC		2004
New	Approved Basic #99-113971 BP	Plan: 1315 Split Level SFR - 1997 UBC	2004
New	Approved Basic #99-113971 BP	Plan: 1315 Split Level SFR - 1997 UBC	2004
New	Approved Basic #99-113971 BP	Plan: 1315 Split Level SFR - 1997 UBC	2004
New	Approved Basic #99-113971 BP	Plan: 1315 Split Level SFR - 1997 UBC	2004
New	2-Story SFR w/attached garage.		2004
New	Approved Basic #03-104593 BP	Plan: 2058 Rambler Style SFR - 1997 UBC	2004
New	Approved Basic #01-103343 BP	Plan: TS-2303 Two Story SFR ....1997 UBC	2004
New	2-story w/ unfinished basement & garage		2004
New	2 story SFR w/attached garage 1997 UBC		2004
New	One-story SFR		2004
New	One-story SFR over garage/storage		2004
New	Two story SFR with attached garage		2004
New	1 story SFR w/ unfinished basement & attached garage		2004
New	Two Story SFR - 1997 UBC		2004
New	Tri-level w/garage		2004
New	Two Story SFR with Attached Garage	2003 IRC	2004
New	2 Story sfr with 3 car garage		2004
New	Two-story SFR - 1997UBC	Plan: 2870A3F-2	2004
New	Approved Basic #01-106757 BP	Plan: 706 - revised Two Story SFR - 1997 UBC	2004
New	Approved Basic #01-106753 BP	Plan: 702 revised Two Story SFR - 1997 UBC	2004
New	Approved Basic #01-106754 BP	Plan: 703 - revised Two Story SFR - 1997 UBC	2004
New	2-story w/garage		2004
New	Approved Basic #01-106756 BP	Plan: 705 - revised Two Story SFR - 1997 UBC	2004
New	Approved Basic #01-106755 BP	Plan: 704 - revised Two Story SFR - 1997 UBC	2004
New	2-Story SFR w/attached garage.		2004
New	27x56, 2004 Marlette		2004
New	24x52, 2004 Marlette		2004
New	Two Story SFR with Attached Garage		2004
New	Rambler style SFR w/garage		2004

Accessory Dwelling Units

Index # - File Name: 1.0022 - Single Family Dwellings Data\_Snohomish County.pdf

New	Two Story SFR with Attached Garage		2004
New	2 story single family residence	1997 UBC	2004
New	2 Story SFR w/ 2 Car Garage		2004
New	Rambler with attached 2 car garage		2004
New	Approved Basic 04 110492 BP	Rambler Style SFR w/attac	2004
New	Rambler with Attached Garage		2004
New	Two-story SFR - 1997UBC		2004
New	2 Story SFR with attached garage		2004
New	Approved Basic #03-110854 BP	Plan: Sterling Two Story SFR - 1997 UBC	2004
New	Approved Basic 04-113768BP	2 story SFR w/attached garage 2003 IRC Plan:3040	2004
New	14x64, 1972 Barrington		2004
New	Two story SFR with unfinished basement & attached garage		2004
New	Two story SFR with daylight basement & attached 3-car garage		2004
New	Approved Basic 04-113768BP	2 story SFR w/attached garage 2003 IRC Plan:3040	2004
New	Approved Basic #04-109195 BP	Plan: Eagle 1 Rambler Style SFR - 1997 UBC	2004
New	Approved Basic 04-115047BP.	Underfloor foundation design meets 1997 UBC per A. Husby. 1 :	2004
New	Approved Basic #03-104321 BP	Plan: 2300 B Two Story SFR - 1997 UBC	2004
New	Rambler with Daylight basement		2004
New	1728sf one-story SFR -- 1997 UBC		2004
New	Install triple wide mobile home		2004
New	2-Story SFR w/attached garage.		2004
New	40x68, 2004 Marlette		2004
New	Approved Basic #02-109607 BP	Plan #2265 C/2-3 Two Story SFR - 1997 UBC	2004
New	Two story SFR		2004
New	Approved Basic #03-110854 BP	Plan: Sterling Two Story SFR - 1997 UBC	2004
New	SFR with 2nd floor home office & attached garage - 2003 IRC		2004
New	Two Story SFR with Attached Garage		2004
New	Rambler w/ 4 car Garage		2004
New	SFR with attached garage		2004
New	Rambler with Attached Garage		2004
New	2 story single family		2004
New	One-story SFR -1997 UBC	Builder s Plan: R-2150-3G	2004
New	2-story w/unfinished basement & garage		2004
New	Two-story SFR - 1997 UBC		2004
New	27x56, 2003 Lexington		2004
New	Two-story SFR w/unfinished basement - 1997 UBC		2004
New	Rambler w/ 3 car		2004
New	Rambler style SFR		2004
New	2 Story w/ 2 Car & Basement Garage		2004
New	3 story single family residence		2004
New	Two Story SFR with Attached Garage		2004
New	Approved Basic #03-110297 BP	Plan 1130 Rambler Style Duplex - 1997 UBC	2004
New	Two-story SFR with attached garage - 2003 IRC		2004
New	1950sf 2 story , 4 garage single family residence		2004
New	2 story sfr w/attached 3 car garage		2004
New	Two-story SFR - 1997 UBC		2004
New	2-Story SFR over unfinished daylight basement - 1997 UBC		2004

Accessory Dwelling Units

Index # - File Name: 1.0022 - Single Family Dwellings Data\_Snohomish County.pdf

New	Reversed status to Issued to allow for a one time final inspection per T Rowe request 5/7/12 d				2004
New	Rambler style SFR w/attached garage.				2004
New	Approved Basic #01-112969 BP	Plan No. 2321	Mid-entry SFR - 1997 UBC		2004
New	Approved Basic #01-112969 BP	Plan No. 2321	Mid-entry SFR - 1997 UBC		2004
New	Approved Basic #01-112969 BP	Plan No. 2321	Mid-entry SFR - 1997 UBC		2004
New	27x56, 1997 Palm Harbour				2004
New	2-story w/garage				2004
New	Approved Basic #03-104321 BP	Plan: 2300 B	Two Story SFR - 1997 UBC		2004
New	2-story w/garage				2004
New	Rambler-style SFR with attached garage - 2003 IRC				2004
New	2 story garage with accessory apartment				2004
New	40 X 64 Marlette 2004				2004
New	Two-story SFR - 1997 UBC				2004
New	850 sf detached AA w/ 2 Car Garage				2004
New	2-Story garage with heated living space (office & bath) on 2-nd floor.				2004
New	2-story SFR replacing existing mobile home.				2004
New	2-Story SFR w/attached garage.				2004
New	Rambler style w/garage				2004
New	14 x 70 1979 Skyline				2004
New	2 Story SFR w/ 2 Car				2004
New	2-story w/garage and finished basement				2004
New	1742sf rambler with attached garage - 2003 IRC				2004
New	2-Story SFR w/attached garage.				2004
New	Two-story SFR - 1997 UBC				2004
New	Approved Basic 04-11350BP	2 story SFR w/attached garage	2003 IRC	Plan:2403 Cambridge	2004
New	Approved Basic 04-11350BP	2 story SFR w/attached garage	2003 IRC	Plan:2403 Cambridge	2004
New	Approved Basic 04-11350BP	2 story SFR w/attached garage	2003 IRC	Plan:2403 Cambridge	2004
New	Pending Basic 04-11350BP	2 story SFR w/attached garage	2003 IRC	Plan:2403 Cambridge	2004
New	Approved Basic #03-108705 BP	Plan #2009	Two Story SFR - 1997 UBC		2004
New	SFR- rambler - 1997UBC	Plan: 2218			2004
New	Approved Basic #03-104592 BP	Plan 2003	Rambler Style SFR - 1997UBC		2004
New	2 Story w/ 2 Car Garage				2004
New	2-story SFR w/garage				2004
New	Two-story SFR - 1997UBC				2004
New	One story SFR with unfinished basement				2004
New	Two Story SFR - 1997 UBC				2004
New	Two Story SFR with Attached Garage				2004
New	2-Story SFR w/attached garage.				2004
New	Rambler style SFR				2004
New	2-story w/garage				2004
New	848 square foot accessory apartment				2004
New	2 Story w/attached garage 1997 UBC				2004
New	850 sf Detached Accessory Apartment over Garage				2004
New	Rambler style SFR w/attached garage				2004
New	Three story SFR with attached 3-car garage				2004
New	Two-story SFR - 1997 UBC				2004
New	Two-story SFR w/semi-finished basement				2004

Accessory Dwelling Units

Index # - File Name: 1.0022 - Single Family Dwellings Data\_Snohomish County.pdf

New	Two-story SFR - 1997UBC		2004
New	66 x 28 Marlette 1990 Mobile Home		2004
New	2380 sf Finished Basement w/attached 3-car garage - 1997 UBC		2004
New	2-story w/garage		2004
New	SFR		2004
New	2 story SFR w/unfinished basement & attached garage		2004
New	40 x 60 - 2004 - Marlette - Pacifica Mobile home		2004
New	Ramble Style SFR - 1997 UBC	Plan: 2274	2004
New	Two-story SFR - 1997 UBC	Plan: 2486	2004
New	Two-story SFR - 1997 UBC	Plan: 2486	2004
New	Two Story SFR over Garage	1997 UBC	2004
New	Two Story SFR - 1997 UBC		2004
New	1973 Marlette		2004
New	SFR 1440 with 645 sq ft Finished Basement and 764 Sq Ft Unfinished Basement.		2004
New	28 x 66 1992 Fleetwood		2004
New	Two-story SFR	Plan: M251OB3F-ODB	2004
New	Two Story SFR with basement 1997 UBC		2004
New	24x63, 1991 Dartmouth for Detached Accessory Apartment		2004
New	Two story SFR with attached garage		2004
New	Two-story SFR - 2003 IRC		2004
New	Approved Basic #98-110213BP	Plan #1333 Two Story Duplex - 1997 UBC	2004
New	2- Story SFR		2004
New	Triple wide mobile home		2004
New	2-Story SFR over finished daylight basement		2004
New	2-Story Duplex over Daylight basements w/attached garages.		2004
New	Rambler with Attached Garage		2004
New	2 story single family res with 2 car garage		2004
New	2-Story SFR w/finished Daylight basement & attached garage.		2004
New	SFR Rambler -1997 UBC		2004
New	24 X 48 Double-wide		2004
New	Two-story SFR		2004
New	2-story SFR w/garage		2004
New	Rambler Style SFR w/attached garage.		2004
New	Rambler with Attached Garage		2004
New	Conversion of Temporary Dwelling MH to Accessory Apartment 27 x 40 1985 Fleetwood - Grey		2004
New	2 Story w/ Finished Basement		2004
New	2-story w/covered porch		2004
New	2 Story w/ 3 Car Garage		2004
New	Rambler style SFR with attached 2 car garage		2004
New	2nd Story Accessory Apartment with garage		2004
New	2004 Champion MH		2004
New	Rambler style detached AA w/garage & covered deck		2004
New	Rambler with attached 3-car garage		2004
New	28x33, 2004 Marlette First Edition MH		2004
New	2 Story SFR with Semi-Finished Basement and attached garage		2004
New	Two story SFR: Main story over garage - 1997 UBC		2004
New	2-Story SFR over unfinished basement		2004

Accessory Dwelling Units

Index # - File Name: 1.0022 - Single Family Dwellings Data\_Snohomish County.pdf

New	Rambler style w/garage		2004
New	Two story SFR with attached garage		2004
New	Two Story SFR with Attached Garage	1997 UBC	2004
New	One Story Duplex with Attached Garage		2004
New	Approved Basic #03-100020 BP	Plan: 1549 Rambler Style SFR - 1997 UBC	2004
New	808 sf Detached Accessory Apt		2004
New	2-story w/garage		2004
New	Approved Basic #03-108826 BP	Plan: 1228 Hip Rambler Style SFR - 1997 UBC	2004
New	1400 sq ft Rambler with Attached Garage		2004
New	2-story DUPLEX w/garage		2004
New	Two-story SFR		2004
New	Detached living space w/attached garage		2004
New	Rambler style w/garage & finished basement		2004
New	Rambler Style SFR with attached garage & attached carport.		2004
New	2 story single family residence	1997 UBC	2004
New	EXPIRED WITHOUT COUNTY APPROVAL TO USE OR OCCUPY. SENT TO MICROFICHE. 4/11/07 56		2004
New	Rambler w/garage		2004
New	Approved Basic 04-112373 BP	Two-story SFRw/attached garage	2004
New	2 Story SFR with attached garage		2004
New	36x64, 1979 Silvercrest Chalet		2004
New	Approved Basic 04-114590BP	Plan: 1597 Duplex Two-story Duplex - 1997U	2004
New	Approved Basic 04-114590BP	Plan: 1597 Duplex Two-story Duplex - 1997U	2004
New	Two Story SFR - 1997 UBC		2004
New	Rambler Style SFR - 1997 UBC		2004
New	2004 - 27 X 58 Mobile Home used for Accessory Apartment		2004
New	Rambler Style SFR - 1997 UBC		2004
New	2 Story SFR w/ 4 Car		2004
New	Rambler style SFR w/attached garage and covered porch		2004
New	1999 Goldenwest 28 x 60		2004
New	2-Story SFR w/covered porch.		2004
New	Rambler style w/unfinished basement - 1997 UBC		2004
New	Approved Basic 04 115397 BP	Builders Plan: 1742 One-story SFR - 19	2004
New	Approved Basic #03-108093 BP	Plan: 1968 Mid-Entry w/ finished basememnt	2004
New	2-Story SFR w/attached garage.		2004
New	Two story SFR		2004
New	640 Sq Ft Second Story Detached Accessory Apt Over 2080 Sq Ft Detached Garage		2004
New	2 story SFR w/attached garage IRC 2003		2004
New	Two-story SFR - 1997 UBC	Builder s Plan: 2526	2004
New	28 x 52 2004 Palm Harbor		2004
New	Two-story SFR with attached garage - 1997 UBC		2004
New	2004 26 8 X 60 Marlette Pacifica MH		2004
New	66 x 14 - 1983 - Single Wide Fleetwood Mobile Home for Temporary Dwelling		2004
New	One-story SFR - 1997UBC		2004
New	Approved Basic #00-107111 BP	Rambler style SFR.....1997 UBC	2004
New	One-story SFR		2004
New	2004, 40x60, KMC,		2004
New	850 sf Detached Accessory Apartment - 1997 UBC		2004



Accessory Dwelling Units

Index # - File Name: 1.0022 - Single Family Dwellings Data\_Snohomish County.pdf

New	30 x 70 - 2004 Marlette - Mobile home.	2004
New	Rambler style SFR w/attached garage.	2004
New	Rambler style SFR w/attached garage.	2004
New	Approved Basic #99-115639 BP Plan: 1356 Two Story Duplex - 1997 UBC	2004
New	Two Story SFR with Attached Garage	2004
New	Two story SFR with attached 2-car garage	2004
New	1978 Skyline 24 x 56	2004
New	Rambler with attached 3 car garage	2004
New	Approved Basic #03-108550 BP Plan: Plan 1549 Two-story Duplex - 1997 UB	2004
New	Approved Basic #98-110231BP Plan: Rutledge 1365 One-story SFR w/finisl	2004
New	Single story w/ semi finished basement & 1 car garage	2004
New	Two Story SFR w/finished basement - 1997 UBC	2004
New	2 story sfr w/2 car garage	2004
New	Rambler style w/finished basement & garage	2004
New	26 8 x 57 4 2004 Marlette Sierra Vista	2004
New	2-Story SFR w/attached garage.	2004
New	Two Story SFR with Semi-finished Basement and Attached Garage	2004
New	One-story SFR - 1997 UBC	2004
New	Convert Existing Temporary Mobile Home to Main Dwelling Unit on Property	2004
New	27x52, 1993 Golden West	2004
New	40 x 48 - 2004 - Marlette - Mobile Home.	2004
New	27 X 52 MH	2004
New	2 Story SFR with unfinished basement 1997 UBC	2004
New	Rambler style w/finished basement & garage	2004
New	2 story sfr w/finished basement & 2 car garage	2004
New	Rambler style w/garage	2004
New	Two-story SFR w/attached garage	2004
New	Rambler style w/garage	2004
New	Rambler-style SFR with attached garage - 2003 IRC	2004
New	27x64 2000 Palm Harbor Deschutes	2004
New	2-story w/finished basement and covered porch + attic as un-heated storage	2004
New	Two-story SFR with basement Garage/Shop	2004
New	Two-story SFR with basement Garage/Shop	2004
New	27x57, 2004 Sierra Vista	2004
New	1824-sq. ft Rambler style SFR w/attached garage -AND- w/attached 494-sq. ft. accessory apartnr	2004
New	2-Story SFR.	2004
New	27x44, 2003 Greenbrier	2004
New	27 x 52 2004 Fleetwood Mobile Home	2004
New	2004sf SFR Rambler - 1997UBC 3 bedroom design	2004
New	28x44 (2001) Goldenwest	2004
New	600sf SFR with daylight garage - 2003 IRC	2004
New	38x60, 2004 Fuqua Mobile home	2004
New	2 Story SFR with attached garage	2004
New	Two strory SFR with attached Garage	2004
New	Rambler Style duplex - 1997 UBC	2004
New	One-story SFR	2004
New	40x60, 2005 Karsten	2004

Accessory Dwelling Units

Index # - File Name: 1.0022 - Single Family Dwellings Data\_Snohomish County.pdf

New	2-Story SFR over daylight basement SFR w/attached garage & attached retaining wall	2004
New	3139 square foot duplex	2004
New	Two Story SFR with Attached Garage 2003 IRC	2004
New	2 Story w/ Finished Basement	2004
New	2225 sf rambler-style SFR - 1997 UBC	2004
New	2-Story SFR w/attached garage.	2004
New	2-Story SFR w/attached 3-car garage.	2004
New	SFR over 2-car garage	2004
New	28 x 60 - 1992 - Kit - Mobile Home.	2004
New	Two Story SFR - 1997 UBC	2004
New	3256 sf 2-story w/544 sf covered deck/porch, and 58 sf open decks	2004
New	Rambler style SFR w/attached garage & 290-sq ft, 2-nd floor bonus room .	2004
New	28 x 70 - 2004 - Champion Silvercrest	2004
New	Approved Basic 04-118656BP Plan: 2-1755-2 Two-story SFR with attache	2004
New	480 sf Detached Accessory Apt w/ Covered Porches	2004
New	2-story SFR w/garage	2004
New	One-story SFR - 1997 UBC	2004
New	One-story SFR with finished & unfinished basement - 1997 UBC	2004
New	2 Story SFR with attached garage, carport, covered porch and deck	2004
New	864 sf SFR	2004
New	This permit is a revision to issued permit (04-114524) by deleting 2nd floor (384 sf) and removir	2004
New	SFR Rambler w/attached garage 1997 UBC	2004
New	Approved Basic #01-111924 BP Rambler Style SFR - 1997 UBC	2004
New	Mid Entry SFR	2004
New	Two Story SFR - 1997 UBC	2004
New	2272 square foot rambler	2004
New	Rambler with Attached Garage	2004
New	24 x 40 - 2001 - Redman - Mobile Home.	2004
New	SFR--	2004
New	2004 27 X 56 Grand doublewide MH	2004
New	SFR with attached Garage/Shop - 1997 UBC	2004
New	2-Story SFR w/attached garage.	2004
New	Two Story SFR with 800 Sq Ft Semi-finished Basement and Attached Garage	2004
New	2-story w/garage	2004
New	Two-story SFR - 1997UBC	2004
New	26 x 48 2004 Champion Mobile Home	2004
New	2-Story SFR w/attached garage & covered porch.	2004
New	Rambler style SFR w/garage	2004
New	850 sf detached accessory apartment	2004
New	2-story w/unfin. basement	2004
New	Rambler with Attached Garage	2004
New	Rambler style SFR w/attached garage.	2004
New	Rambler style SFR w/attached garage.	2004
New	2 story SFR with finished basement and 3 car garage	2004
New	2 Story SFR with attached garage and covered porch	2004
New	One-story SFR w/attached carport	2004
New	2-story SFR w/garage	2004

Accessory Dwelling Units

Index # - File Name: 1.0022 - Single Family Dwellings Data\_Snohomish County.pdf

New	Rambler style SFR w/attached garage.		2004
New	1655 sf rambler bldrs plan number 1655	1997 UBC	2004
New	2004 Marlette 27 x 68		2004
New	2-Story SFR.		2004
New	28x66, 1988 Liberty MH		2004
New	Rambler Style SFR - 1997 UBC		2004
New	28 x 44 Redman Ridgedale	1990	2004
New	Rambler style SFR		2004
New	Rambler style SFR w/attached garage.		2004
New	Approved Basic 04-116984BP	Plan: 1697 Daylight SFR with daylight	2004
New	Two-story SFR		2004
New	Permit to complete inspection (final) under previous permits 236362 and 250817.		2004
New	24 x 44	1984 USA	2004
New	2 Story w/ 3rd Floor Loft and Unfin Basement		2004
New	Rambler style SFR - 1997 UBC		2004
New	2 story single family residence		2004
New	Split Entry SFR - 1997 UBC		2004
New	1100 sf rambler style SFR w/ 173 sf covered porch		2004
New	2-Story SFR w/attached garage.		2004
New	2005 66 X 42 w/ tag unit 22 X 14	Skyline	2004
New	2-Story SFR w/attached garage replacing existing mobile home.		2004
New	2002 Liberty 40 x 27		2004
New	2272sf Rambler-stye SFR - 1997 UBC		2004
New	Two Story SFR with Basement		2004
New	1696sf rambler with attached garage - 2003 IRC		2004
New	2-story w/garage		2004
New	2001 24x44 Marlette		2004
New	2-Story SFR over basement garage/shop.		2004
New	2 story single family residence		2004
New	Two Story SFR with Attached garage		2004
New	SFR with Attached Garage	2003 IRC	2004
New	Approved Basic 04-113407BP	2 story SFR w/attached garage 1997 UBC	Plan:Appleton 2004
New	Conversion of Temporary Dwelling to main residence	41x68 2003 Palm Harbor	2004
New	Approved Basic #03-104592 BP	Plan 2003 Rambler Style SFR - 1997UBC	2004
New	Two story SFR		2004
New	58 X 28 Palm Harbor 58A4	2004	2004
New	850 sf Rambler style w/garage accessory apartment		2004
New	Approved Basic #03-106139 BP	Plan: 3579 Two Story SFR - 1997 UBC	2004
New	2-story w/garage		2004
New	28 x 44 1999 Marlette		2004
New	2 story single family residence		2004
New	2-Story SFR w/attached garage.		2004
New	2 story SFR with unfinished daylight basement		2004
New	Approved Basic #00-100660 BP	Plan: 1803 Rambler Style SFR - 1997 UBC	2004
New	Approved Basic #00-105331 BP	Bldrs Plan No. 1932 Two Story SFR - 1997 UBC	2004
New	SFR w/unfinished basement	1997 UBC	2004
New	Approved Basic #00-100660 BP	Plan: 1803 Rambler Style SFR - 1997 UBC	2004

Accessory Dwelling Units

Index # - File Name: 1.0022 - Single Family Dwellings Data\_Snohomish County.pdf

New	2 story SFR with attached garage	2004
New	28 x 38 - 2004 - Skyline Mobile Home.	2004
New	Two Story SFR w/semi-finished basement - 1997 UBC	2004
New	EXPIRED WITHOUT COUNTY APPROVAL TO USE OR OCCUPY. SENT TO MICORFISHE 4/2/07 1144	2004
New	Two Story SFR	2004
New	2 Story w/ 3 Car	2004
New	Detached Garage w/ 2nd Floor Accessory Apartment - 1997 UBC	2004
New	Approved Basic #03-100446 BP Plan: 2838 Two Story SFR - 1997 UBC	2004
New	1712 s.f. sfr w/1187 s.f finished basement & 525 s.f. unfinished basement	2004
New	27x56 2003 Skyline Lexington	2004
New	2-Story SFR over unfinished basement w/attached Garage	2004
New	2-story SFR w/garage	2004
New	Two-story SFR w/finished basement & attached garage - 1997 UBC	2004
New	Two story SFR with attached garage	2004
New	2 story SFR with attached garage	2004
New	2-story SFR w/unfinished basement.....1997 UBC	2004
New	Rambler style SFR w/covered porch.	2004
New	2004 Golden West - CM663K 66 x 40	2004
New	Rambler style SFR w/attached garage.	2004
New	Two-story SFR w/garage	2004
New	28 x 68 2005 Fleetwood Entertainer Mobile Home	2004
New	Two story SFR	2004
New	Rambler style SFR w/garage	2004
New	Two story SFR with daylight basement	2004
New	24 x 52 - 1981 - Gibraltar	2004
New	Approved Basic #03-104593 BP Plan: 2058 Rambler Style SFR - 1997 UBC	2004
New	Convert 1200 sf of shop and 400 sf of hanger space to Living Area	2004
New	27x57, 2004 Marlette	2004
New	Two story SFR with attached 2-car garage	2004
New	Approved Basic #03-104593 BP Plan: 2058 Rambler Style SFR - 1997 UBC	2004
New	Two-story SFR	2004
New	2543sf ramblar with attached garage - 2003 IRC	2004
New	2-Story SFR w/attached garage.	2004
New	Approved Basic #98-150985BP Plan # 5911E Two Story SFR - 1997 UBC	2004
New	28x56, 2004 Fleetwood	2004
New	Two story SFR - 1997 UBC	2004
New	2 Story SFR w/ 3 Car Garage	2004
New	Two Story SFR with Attached Garage	2004
New	SFR 1168 Sq ft with 492 sq ft uncovered deck	2004
New	SFR with Finished Basement and Garage	2004
New	Two Story SFR with Semit Finished Basement and Attached Garage	2004
New	Two-story w/finished & unfinished basement	2004
New	1740 sf Two-story SFR - 1997 UBC See Comments file in GR 03/16/2004 DKN	2004
New	Two-story SFR with attached garage - 2003 IRC	2004
New	One-story SFR/w attached garage	2004
New	66 X 40 Karsten (2004)	2004
New	27 x 60 with 14 x 36 Pod 2004 Fleetwood Mobile Home	2004

Accessory Dwelling Units

Index # - File Name: 1.0022 - Single Family Dwellings Data\_Snohomish County.pdf

New	Daylight Basement Rambler					2005
New	Two Story SFR					2005
New	2 story sfr with unfinished basement and 2 car garage					2005
New	2-Story SFR w/attached garage.					2005
New	Rambler style w/loft & attached garage					2005
New	2-Story SFR w/attached garage - 1997 UBC					2005
New	1685 sf rambler style SFR - 1997UBC					2005
New	2-Story SFR over garage					2005
New	2005 40 X 56 Triple Wide MH					2005
New	One-story sfr with garage					2005
New	1983 Single-wide 12 x 60					2005
New	Approved basic 05-101046 BP	2003 IRC	Plan # 1361-2+DLB (2 1/2 car)			2005
New	Approved Basic 05-100129		Builder Plan Name Cypress	2 story single family - 2		2005
New	2548 sq ft SFR with 2548 sq ft unfinished Basement & attached Garage					2005
New	3rd floor 593 sq ft storage/heated living space					2005
New	Rambler w/ 3 car garage					2005
New	2-story SFR w/garage					2005
New	2005 27 X 46 8 Doublewide MH					2005
New	2-Story SFR w/attached garage.					2005
New	2 Story w/ 2 Car					2005
New	Two story with attached 2-car garage					2005
New	Approved Basic 04-121030BP	2003 IRC	Plan:One	SFR w/ attached garage		2005
New	Expired w/o County approval to use or occupy 8-30-07			New SFR w/attached garage		2005
New	Approved 04-118946BP		Plan: 1791	Rambler-style SFR with attached		2005
New	Two Story SFR with attached Garage					2005
New	2-story w/garage					2005
New	Approved Basic 04-121240 BP		Mid entry w/attached garage	2003 IRC	PI	2005
New	Approved Basic 04-113593BP		Plan: 176O Flat	Two-story SFR - 2003 IRC		2005
New	Approved Basic 04-113593BP		Plan: 1176 Flat	Two-story SFR - 2003 IRC		2005
New	Approved Basic 04-118667BP	2 story SFR w/attached garage	2003 IRC	Plan:1172 ORO		2005
New	Approved Basic 04-113750BP		Plan 1174	Two-story SFR	2003 IRC	2005
New	Approved Basic 04-113593BP		Plan: 176O Flat	Two-story SFR - 2003 IRC		2005
New	Approved Basic 04-118667BP	2 story SFR w/attached garage	2003 IRC	Plan:1172 ORO		2005
New	Rambler sfr with garage attached via a breezeway					2005
New	2-Story SFR w/attached garage.					2005
New	Two Story SFR - 1997 UBC					2005
New	2-story sfr w/attached garage					2005
New	Fleetwood - Barrington 1986 Mobile Home					2005
New	1994 14x66					2005
New	3 bedroom 2 story w/ attchd 2 car garage					2005
New	One story SFR - 2003 IRC					2005
New	Split Entry style SFR w/attached garage and finished lower level.					2005
New	Two-story SFR					2005
New	2005 Karsten 68 x 41					2005
New	Two story SFR with attached Garage					2005
New	Two story SFR with attached Garage					2005
New	Two story SFR with attached Garage					2005

Accessory Dwelling Units

Index # - File Name: 1.0022 - Single Family Dwellings Data\_Snohomish County.pdf

New	Two story SFR with attached Garage				2005
New	One story SFR with attached garage				2005
New	1978 - 20 x 48 Brookwood - Mobile Home.				2005
New	Rambler style SFR w/attached garage.				2005
New	Approved Basic 05-124338 BP	2003 IRC	Plan # 2454	Rambler w/attached Ga	2005
New	Rambler w/ attchd 2 car garage				2005
New	SFR with finished daylight basement - 2003 IRC				2005
New	3 - story sfr w/attached garage				2005
New	Duplex 2 story duplex w/garage	2003 IRC	Plan:1777 Duplex		2005
New	768 sq ft Vacation Cabin				2005
New	839 square foot detached accessory apartment				2005
New	Two story sfr with garage.				2005
New	Two-Story SFR - 1997UBC				2005
New	Approved Basic 04-121335BP	Rambler style SFR w/garage	2003 IRC	Plan:1798 Rambler	2005
New	2-Story SFR w/attached garage				2005
New	Two-story SFR w/attic storage				2005
New	2-story SFR w/basement and garage				2005
New	1000 sq ft SFR above 1200 sq ft Garage				2005
New	Two Story SFR with Attached Garage	2003 IRC			2005
New	SFR Rambler w/ attchd 2 car garage (1776 sqft)				2005
New	Two story SFR with attached Garage				2005
New	2-story sfr w/ attached garage.				2005
New	Rambler w/ basement & attchd. 2 car garage				2005
New	2005 Marlette 27 x 57				2005
New	Rambler style w/garage				2005
New	1,922 sf Rambler with attached garage				2005
New	Approved Basic #117192BP		Plan 2225 - 3 Car	Rambler with A	2005
New	Rambler sfr with attached garage				2005
New	Two Story SFR with Attached Garage				2005
New	2116 rambler style single family residence				2005
New	SFR w/garage				2005
New	Two story SFR with Unfinished Basement				2005
New	One-story SFR w/finished basement				2005
New	Two story SFR with attached garage				2005
New	Two story SFR with attached garage				2005
New	One story SFR with attached garage				2005
New	2005 44 X 27 Doublewide MH				2005
New	Two-story sfr				2005
New	2-story w/unfinished basement & garage				2005
New	40 x 68 Fleetwood 2005				2005
New	720 sq ft SFR with attached garage				2005
New	Rambler style w/garage				2005
New	Approved Basic 04-117192BP	2003 IRC		Plan 2225 - 3 Car Ram	2005
New	1984 - 14 X 64 Single Wide MH for Accessory Apartment				2005
New	2-story SFR w/garage				2005
New	MH as Accessory Apartment , 27 x 48	2002 Fleetwood			2005
New	40x52 AA/MH				2005

Accessory Dwelling Units

Index # - File Name: 1.0022 - Single Family Dwellings Data\_Snohomish County.pdf

New	1466 sq ft Rambler with attached Garage	2005
New	Single-wide 1978 Ridgewood Mobile Home	2005
New	2,350 sf Rambler with attached garage	2005
New	Two=story SFR - 2003 IRC	2005
New	2-Story SFR w/attached garage	2005
New	788 SF Detached Accessory Apartment with 513 SF Attached Garage	2005
New	Rambler w/ attchd 3 car garage	2005
New	1995 28 X 60 Fleetwood Gilbralter MH	2005
New	Two story SFR with Attached Garage	2005
New	Two-story SFR	2005
New	624-sq. ft. GUESTHOUSE + 1296-sq. ft. attached garage.	2005
New	27 x 65 2005 Fleetwood	2005
New	Rambler style SFR w/garage & covered porch/deck	2005
New	One-story sfr with garage	2005
New	Rambler sfr w/attached garage	2005
New	2-story sfr w/attached garage	2005
New	Approved Basic 05-118343 BP 2003 IRC Plan 3146 SFR w/attached 3 car gara	2005
New	Garage w/ 2nd story living space and storage	2005
New	Two-story SFR	2005
New	Two story SFR with attached garage	2005
New	1855 sq ft SFR with attached Garage	2005
New	Accessory Apartment Manufactured Home	2005
New	1416 sq ft Rambler	2005
New	Two story SFR with attached garage	2005
New	One-story sfr with basement and garage	2005
New	Mobile home 2005 Golden West, Country Manor 40 x 68	2005
New	2-story SFR	2005
New	Double-Wide Moble Home to be used as a detached accessory apartment	2005
New	Rambler w/ attchd 3 car garage	2005
New	2 story single family residence with 2 car garage	2005
New	2-story SFR w/garage	2005
New	Approved Basic 05- 122321BP 2003 IRC 2 story SFR w/attached garage Plan: 252	2005
New	2-story SFR w/garage	2005
New	Approved Basic 05-118340BP 2003 iIRC Plan:3146 rambler style single family	2005
New	Rambler (2,365 sqft)	2005
New	Two story SFR with attached Garage	2005
New	Basement Rambler	2005
New	One-story SFR	2005
New	2492 sq ft Rambler with attached Garage	2005
New	Ramber w/attached garage	2005
New	28 x 66 1986 Goldenwest	2005
New	One-story sfr	2005
New	Two-story sfr	2005
New	Two story SFR with attached Garage	2005
New	2276 sq ft daylight rambler with attached garage	2005
New	2 story w/ attched 2 car garage	2005
New	Two story SFR with attached Garage	2005

Accessory Dwelling Units

Index # - File Name: 1.0022 - Single Family Dwellings Data\_Snohomish County.pdf

New	One story SFR with attached garage	2005
New	One story SFR - 2003 IRC	2005
New	Detached Accessory apartment w/ covered porch & atcthd carport	2005
New	1 story SFR w/ atcthd. 3 car garage	2005
New	840-sq. ft. detached accessory apartment w/attached 792-sq.ft. carport & attached 528 sq.ft. ga	2005
New	Two story SFR with attached Garage	2005
New	Two story SFR with attached garage	2005
New	Rambler style w/garage	2005
New	Rambler style SFR w/attached garage.	2005
New	Two-story SFR w/attached garage.	2005
New	28x44, 1999 Palm Harbor	2005
New	Two-story SFR with attached garage - 2003 IRC	2005
New	Rambler with attached garage - 2003 IRC	2005
New	2,542 sq ft SFR with attached Garage	2005
New	SFR with 794sf finished daylight basement - 2003 IRC	2005
New	Mobile Home	2005
New	2-story sfr w/attached garage	2005
New	Two-story sfr with attached garage	2005
New	Rambler with basement and attached garage	2005
New	SFR over Garage	2005
New	2600 sq ft Duplex with attached Garage	2005
New	2-Story SFR w/attached garage.	2005
New	Two story SFR with attached Garage	2005
New	One-story SFR w/finished basement	2005
New	Two-story SFR	2005
New	One story SFR - 2003 IRC	2005
New	2-Story SFR over unfinished basement w/attached garage	2005
New	Two Story SFR with Attched Garage	2005
New	split entry sfr w/attached garage	2005
New	2 story split level sfr 2003 IRC.	2005
New	Two-story sfr with garage	2005
New	SFR with Unfinished Basement and Attached Garage	2005
New	Two story SFR with unfinished basement	2005
New	SFR with 504-SF Unfinished Basement and Attached Garage.	2005
New	2005 Golden West Doublewide MH	2005
New	SFR over Garage	2005
New	Two story SFR with attached garage	2005
New	Multi-story SFR w/ partial unfinished basement & attached garage	2005
New	1548 sf rambler style SFR	2005
New	Two-story SFR	2005
New	Rambler style SFR w/attached garage.	2005
New	Two story SFR with attached Garage	2005
New	2 story SFR w/ fininshed basement & 3 car attached garage / shop	2005
New	One story SFR - 2003 IRC	2005
New	SFR Rambler w/ 3 Car	2005
New	2 - story SFR w/attached garage	2005
New	2694 sq ft rambler with semi finished basement & attached garage	2005



Accessory Dwelling Units

Index # - File Name: 1.0022 - Single Family Dwellings Data\_Snohomish County.pdf

New	Two-story SFR w/unfinished basement	Builders Plan: 2B-	2005
New	Two-story SFR - 2003 IRC		2005
New	Two-story sfr with attached garage		2005
New	Rambler w/finished basement/attached garage		2005
New	1214 sq ft SFR with 521 sq ft unfinished Basement		2005
New	1214 sq ft SFR with 521 sq ft unfinished Basement		2005
New	2-Story SFR w/attached garage.		2005
New	Daylight basement rambler with semi-finished basement, attached garage and covered porches		2005
New	2005 64 X 27 Doublewide MH		2005
New	One-story SFR w/basement garage/shop		2005
New	SFR with Finished Basement and Attached Garage		2005
New	Rambler StyleSFR w/attached garage.		2005
New	Rambler with 3 car garage		2005
New	2-story w/covered deck/porch		2005
New	Two-story sfr.		2005
New	2-story SFR w/garage		2005
New	2 story SFR w/ 2 car garage		2005
New	2-Story SFR w/attached garage.		2005
New	Rambler with attached garage		2005
New	2004 26 8 X 44 Doublewide MH		2005
New	One-story sfr with 3-car garage		2005
New	Rambler style SFR		2005
New	2-story SFR w/garage		2005
New	2301 sq ft Rambler with attached garage		2005
New	2014 sq ft Rambler with 484 sq ft Basement & attached Garage		2005
New	27 x 64 (27 x 56 living) Marlette 2005 Accessory Dwelling		2005
New	SFR. Main floor over daylight basement		2005
New	Two-story sfr with garage		2005
New	Rambler style SFR w/covered porch		2005
New	2 story sfr		2005
New	2459 Rambler		2005
New	One-story SFR		2005
New	2006 Oakwood Manufactured Home		2005
New	2005 Greenbriar 27 x 44		2005
New	2-Story SFR w/attached garage		2005
New	Rambler w/attached garage		2005
New	2007 sq ft Rambler with attached garage		2005
New	One-story sfr with 2-car garage replacing mobile home		2005
New	SFR Rambler w/attached garage		2005
New	27 x 56 - 2006 - Karsten - Mobile home.		2005
New	2-Story SFR w/attached garage.		2005
New	2-story SFR w/garage		2005
New	2597 sq ft Rambler with attached garage		2005
New	Rambler w/attached garage		2005
New	Convert existing temporary dwelling mobile home to detached accessory apartment		2005
New	SFR with 559 SF Finished Basement and Attached Garage		2005
New	Approved Basic 05-100241BP 2003 IRC Plan: 1561 2 story Duplex w/attached garage		2005

Accessory Dwelling Units

Index # - File Name: 1.0022 - Single Family Dwellings Data\_Snohomish County.pdf

New	Rambler style SFR w/attached single garage.		2005	
New	Two Story SFR with Attached Garage	2003 IRC	2005	
New	2 story SFR w/ attchd garage		2005	
New	Approved Basic 05-100241BP	2003 IRC Plan: 1561	2 story Duplex w/attached ga	2005
New	2 Story SFR w/attached garage.		2005	
New	2 story single family residence with 3 car garage		2005	
New	Two-story sfr with attached garage		2005	
New	Two story SFR with attached garage		2005	
New	2 story (2131 sf) SFR w/ attchd 2 car garage		2005	
New	2 story single family with 3 car garage		2005	
New	rebuild 3440 SF 2 story single family residence with attached 2 car garage (original burned-using		2005	
New	Two story SFR with attached garage - 2003 IRC		2005	
New	2450 sq ft SFR with attached Garage		2005	
New	2 Story w Covered Deck & Unfinished Basement		2005	
New	Mobile Home		2005	
New	Single Family Residence Main floor and semi finished daylight basement		2005	
New	LETTER RESCINDING (LIFTING) OF STOP WORK ORDER Recieved 8/10/06 OK to Inspect Mick 9/2		2005	
New	Champion Mobile Home 66 x 26 8		2005	
New	Accessory apartment over garage - 1997 UBC		2005	
New	40x54, 2005 Lexington		2005	
New	2 story SFR w/attached garage		2005	
New	Two story SFR with Daylight Basement & attached Garage		2005	
New	2005 Palm Harbor 4P366A1 Doublewide MH		2005	
New	One-story sfr with attached garage		2005	
New	840sf guest house with 1536sf attached garage - 2003 IRC		2005	
New	Two-story SFR with attached 2-car garage - 2003 IRC		2005	
New	1196 sq ft Rambler		2005	
New	2136 sq ft Rambler		2005	
New	2 story single family residence with garage		2005	
New	2004 Palm Harbor 41 x 68		2005	
New	Two story SFR w/semi-finished basement	Builders Plan; 3215	2005	
New	2-story w/finished basement and garage		2005	
New	2005 27 X 66 Mobile Home		2005	
New	2004 - 40 X 42 Oakwood Elite/Cascade Villa		2005	
New	2-Story SFR over unfinished daylight basement.		2005	
New	2-story sfr		2005	
New	4,714 sf rambler with attached garage		2005	
New	Two story SFR		2005	
New	2-Stroy SFR w/attached garage replacing existing Mobile home.		2005	
New	Two story SFR with attached Garage		2005	
New	double wide mobile home to be used as a detached accessory apartment		2005	
New	2 story w/ attchd. 2 car garage		2005	
New	2 story w/ attchd. 2 car garage		2005	
New	Two Story SFR with 3397 SF Unfinished Basement and Attached Garage		2005	
New	2-story SFR w/attached garage		2005	
New	Two story SFR		2005	
New	Approved Basic 04-118493BP	Plan: 1757	Two-story SFR with attached 2-car	2005

Accessory Dwelling Units

Index # - File Name: 1.0022 - Single Family Dwellings Data\_Snohomish County.pdf

New	2 story sfr w/attached garage				2005
New	Approved Basic 04-118493BP		Plan: 1757	Two-story SFR with attached 2-car	2005
New	Two story SFR with attached Garage				2005
New	Two story SFR with attached Garage				2005
New	Two story SFR with Semi-finished Basement & attached Garage				2005
New	2-story SFR w/semi-finished basement & garage				2005
New	2-story SFR w/garage				2005
New	One-story sfr with loft and attached garage				2005
New	2006 26 8 X 32 Champion Double Wide MH				2005
New	2-Story SFR				2005
New	27 x 67 - 2005 Marlette Mobile Home.				2005
New	Two story duplex with attached single car garage				2005
New	Approved Basic #05-117501 BP	2003 IRC	Plan: 2268		2005
New	Approved Basic #05-117501 BP	2003 IRC	Plan: 2268		2005
New	Approved Basic #05-117501 BP	2003 IRC	Plan: 2268		2005
New	Approved Basic 05- 117501 BP			Builder s Plan: :	2005
New	Approved Basic #05-117501 BP	2003 IRC	Plan: 2268		2005
New	Rambler style SFR w/attached garage.	BFE = 296.5	NGVD		2005
New	Rambler w/attached garage				2005
New	Detached Accessory Apt				2005
New	Two story SFR				2005
New	MOBILE HOME MAKE/YEAR/DIMENSIONS & TYPE OF HEAT ---to be determined.				2005
New	SFR with Attached Garage				2005
New	2-story w/garage				2005
New	Two Story SFR with Semi Finished Basement and Attached Garage				2005
New	2 story SFR w/ basement w/ Attchd 2 car garage				2005
New	2 story w/ attchd. 3 car garage.	(12/6/05, Bentzens changed contractors from Jensen Homes N			2005
New	840 sq ft Accessory Apartment				2005
New	Two story SFR with attached Garage				2005
New	Two story SFR with attached Garage				2005
New	Approved Basic 05-100241BP	2003 IRC	Plan: 1561	Duplex - 2003 IRC	2005
New	Approved Basic 05-100241BP	2003 IRC	Plan: 1561	2 story Duplex w/attached ga	2005
New	Approved Basic 05-100241BP	2003 IRC	Plan: 1561	2 story Duplex w/attached garag	2005
New	760 sq ft recreation room with 1905 sq ft attached garage				2005
New	Two-story sfr with attached garage				2005
New	Two-story sfr with attached garage				2005
New	Rambler - 3,643 sqft w/ 3 car garage & 300 sqft cov d porch				2005
New	Two-story SFR with finished daylight basement & attached garage - 2003 IRC				2005
New	Two-story sfr with attached garage				2005
New	Two-story sfr with attached garage				2005
New	2 story Duplex w/ attchd garage				2005
New	*** closed permit and opened new permit 07-112005-RK to finish work jla 10/9/07 *****247				2005
New	1784 sq ft Rambler				2005
New	550 sqft Detchd Accessory Apt, w/ 475 sqft garage				2005
New	2-story SFR with attached Garage				2005
New	Two-story sfr with garage and a heated and finished bonus room over the garage.				2005
New	2-story SFR w/garage				2005

Accessory Dwelling Units

Index # - File Name: 1.0022 - Single Family Dwellings Data\_Snohomish County.pdf

New	Two story SFR with attached garage		2005
New	SFR w/finished basement & attached garage	2003 IRC	2005
New	Two-story SFR with Attached Garage	2003 IRC	2005
		Plan: 2645B3F-OR	
New	780 sf detached accessory apartment		2005
New	rambler style 2137 square foot SFR		2005
New	2-story w/covered deck/porch		2005
New	Two story SFR	Builders Plan: 2870	2005
New	2 story SFR w/ finished basement		2005
New	Two story SFR with attached garage		2005
New	Two-story SFR		2005
New	26x66, 1981 Goldenwest		2005
New	Two story SFR with attached garage		2005
New	Two story SFR with attached Garage		2005
New	2137 SF Rambler with Attached Garage		2005
New	Rambler sfr with attached covered porch/patio and attached garage		2005
New	Two story SFR		2005
New	Two Story SFR		2005
New	Rambler style SFR w/attached garage.		2005
New	26 8 x 66 2002 Marlette Elation		2005
New	40 x 66 - 2005 -Oakwood - Villa Park Mobile Home.		2005
New	Rambler style w/garage		2005
New	One-story sfr with garage		2005
New	Two story SFR with Attached Garage		2005
New	2-story SFR w/covered porch		2005
New	Two Story SFR with Attached Garage		2005
New	Rambler Style SFR - 1997 UBC		2005
New	2363 sq ft Rambler with attached Garage		2005
New	SFR with finished daylight basement & attached garage - 2003 IRC		2005
New	Approved Basic 05 127330 BP	Builder s Plan: 2470 One-s	2005
New	Rambler with finished bonus room over garage - 2003 IRC		2005
New	Approved Basic #04-115976BP	Rambler with Attached Garage	2005
New	28 x 60 - 2006 - Karsten - Mobile Home		2005
New	One-story SFR		2005
New	26 -8 x 60 - 2005 - Karsten Mobile home		2005
New	Two story sfr with garage		2005
New	2005 27 X 52 Doublewide MH		2005
New	2 story with semi finished basement and attached 2 car garage		2005
New	SFR with Semi Finished Basement and Attached Garage		2005
New	Rambler style w/garage & covered porch		2005
New	Approved Basic #04-115978BP	Plan R-2009-3 Two Story SFR with Ati	2005
New	3373 sf rambler w/1132 sf garage, w/481sf covered porch/lanai		2005
New	Two-story sfr with garage		2005
New	2-Story SFR w/attached garage.		2005
New	2-story SFR w/garage		2005
New	Rambler style SFR w/attached garage.		2005
New	Rambler style SFR w/attached garage.		2005
New	2 story SFR w/ atatched 3 car garage		2005

Accessory Dwelling Units

Index # - File Name: 1.0022 - Single Family Dwellings Data\_Snohomish County.pdf

New	27 x 57 -4 - 2005 Marlette Sierra Vista - Mobile Home.	2005
New	2005 60 X 40 Triple Wide MH	2005
New	Rambler style SFR w/attached garage.	2005
New	Two-story Cabin	2005
New	Two Story SFR - 1997 UBC	2005
New	53 4 x 40 6 Skyline 2005 MH	2005
New	2 Story Single Family with 2 car garage	2005
New	2686 sq ft Rambler with attached Garage	2005
New	2866 sq ft Rambler with attached garage	2005
New	Originally a Duplex 2,788 sqft (NOTE: 05-116790 MO issued on November 16, 2005 to change f	2005
New	2 story SFR with unfinished basement	2005
New	SFR with Attached Garage	2005
New	Two-story SFR with attached 3-car garage - 2003 IRC	2005
New	56 X 24 Glsner 1978	2005
New	One-story rambler with 3-car garage.	2005
New	Two story sfr with attached garage	2005
New	2-story SFR w/garage	2005
New	Two-story sfr with attached garage	2005
New	Rambler with attached garage 2003 IRC	2005
New	Two-story SFR with breezeway to attached garage - 2003IRC	2005
New	Two story SFR with attached garage	2005
New	Two story SFR with attached Garage	2005
New	Approved basic 04-121335 BP Rambler style w/garage 2003 IRC Plan	2005
New	Rambler 2,283 sqft w/ atcthd 3 car garage	2005
New	Approved Basic 05-100129BP Builder Plan Name Cypress 2 story single family	2005
New	Rambler w/ semi finished basement & atcthd 3 car garage	2005
New	Approved Basic 05-100129 Builder Plan Name Cypress 2 story single family - 2	2005
New	Approved Basic 05-100129BP Plan: Cypress 2 story single family - 2003 IRC	2005
New	Approved basic 04-121335 BP Rambler style w/garage 2003 IRC Plan	2005
New	2-Story SFR w/attached garage.	2005
New	Two-story Duplex with attached garage - 2003 IRC	2005
New	2-story SFR w/semi-finished basement	2005
New	Duplex	2005
New	Approved Basic 05-100640BP 2003 IRC Plan:Covington 2540	2005
New	One-story sfr with garage	2005
New	PERMIT OWNERSHIP TRANSFERRED FROM NOTABLE ENTERPRISES, LLC, TO CASCADE PACIFIC BU	2005
New	PERMIT OWNERSHIP TRANSFERRED FROM NOTABLE ENTERPRISES, LLC, TO CASCADE PACIFIC BU	2005
New	Rambler style w/garage	2005
New	Two story SFR with attached garage	2005
New	Two story SFR with attached Garage	2005
New	Approved Basic 05-121BP 2003 IRC Rambler style SFR w/attached garage Plan: 216	2005
New	Approved basic 05-117114 BP 2003 IRC Plan# 1369 2 story w/attached garage	2005
New	Approved basic 05-117114 BP 2003 IRC Plan# 1369 2 story w/attached garage	2005
New	27 x 52 2002 Golden West Permit to finish work on expired permit 01-112380MH	2005
New	Approved Basic 05-121291BP 2003 IRC Rambler style SFR w/attached garage Plan:	2005
New	Two-story sfr with garage	2005
New	2-story sfr w/attached garage	2005

Accessory Dwelling Units

Index # - File Name: 1.0022 - Single Family Dwellings Data\_Snohomish County.pdf

New	Approved Basic #05-118962 BP	2003 IRC	2 story SFR w/attached garage	Plan:M2625A3	2005
New	2-Story SFR w/attached garage				2005
New	Rambler style SFR w/attached garage.				2005
New	Two story SFR				2005
New	Rambler style w/garage & covered porch				2005
New	Two Story SFR with Attached Garage	2003 IRC			2005
New	Mobile Home				2005
New	26 8 x66 2002 Marlette Elation				2005
New	2 story single family residence				2005
New	triple wide mobile home				2005
New	Approved Basic # 05-122197 BP	2003 IRC	Plan: 2994		2005
New	2524 sq ft SFR with attached Garage *** NSF CHECK 11/04/05. QUESTIONS CONTACT A/R.***				2005
New	2-story SFR w/basement & carport				2005
New	2225 sq ft Rambler with attached garage				2005
New	26 8 x66 2002 Marlette Elation				2005
New	Two Story SFR w/Unfinished Basement - 1997 UBC				2005
New	Two story SFR with attached garage				2005
New	Rambler style SFR w/attached carport.				2005
New	Two-story SFR w/garage				2005
New	Two Story SFR with Attached Garage				2005
New	Rambler w/ attch 3 car garage				2005
New	One-story sfr with attached garage				2005
New	Rambler w/ attchd. 2 car garage reinspection fee reduced to \$60.00 per Mickiewicz 05-19-06 TI				2005
New	Approved Basic #04-115976BP		Rambler with Attached Garage		2005
New	One-story SFR				2005
New	Convert semi-finished basement to finished				2005
New	Rambler w/ finished basement & attchd 3 car garage				2005
New	Approved basic 05-101044 BP	2003 IRC	Plan 1361-2 DLB (2 car)		2005
New	Rambler with Attached Garage				2005
New	Two-story sfr with attached garage				2005
New	rambler style w/garage				2005
New	Daylight Rambler semi finished basment w/attached garage				2005
New	Two story SFR with attached garage				2005
New	Two story SFR with attached Garage				2005
New	Approved Basic 04-121240 BP		Mid-entry w/attached garage	2003 IRC P	2005
New	Approved Basic 05-121174-BP	2003 IRC	2 story SFR w/attached garage	Plan: 3464-A	2005
New	Approved Basic 05-117816 BP	2003 IRC	Plan# 3153	2-story sfr w/attached garage	2005
New	Approved Basic Plan 05-101251BP	2003 IRC	Plan: M3050B2F1		2005
New	Approved Basic 04-121723BP		Plan: M3049A3F-0	Two-story SFR with attacl	2005
New	Approveed Basic 05-100726BP	2003 IRC	Plan: M2805A3FT-2		2005
New	Approved Basic 04-121723BP		Plan: M3049A3F-0	Two-story SFR with attac	2005
New	Approved Basic 05-100186BP		Plan: M3295A2F-0	Two-story SFR with atta	2005
New	Approved Basic 05-100614BP		Plan: 3455B3FT-0		2005
New	Approved Basic 04-121548BP		Plan: M3415A3FT-0	Two-story SFR with atta	2005
New	Approved Basic 04-121539BP		Plan: M3700C3FT-0	Two-story SFR with attacl	2005
New	Approved Basic 04-121543BP		Plans: M2960A3FT-0	Two-story SFR with attacl	2005
New	Approved Basic 04-121551BP		Plan: M3700D3FT-0	Two-story SFR with at	2005

Accessory Dwelling Units

Index # - File Name: 1.0022 - Single Family Dwellings Data\_Snohomish County.pdf

New	Two-story SFR with attached 2-car garage - 2003 IRC		Plan: M3295A2F-0	2005	
New	Approved Basic 04-121723BP		Plan: M3049A3F-0	Two-story SFR with attacl	2005
New	Approved Basic 05-100182BP		Plan: M3300D3FT-1	Two-story SFR with att	2005
New	Approved Basic 04-121543BP		Plan: 2960A3FT-0	Two-story SFR with attache	2005
New	Approved Basic 05-100905BP	2003 IRC	Plan: M2876A2F-0		2005
New	Approved Basic 05-100715BP	2003 IRC	Plan: M3615A3F		2005
New	Approved Basic 04- 121543BP		Plan: M2960A3FT-0	Two-story SFR with atta	2005
New	Approved Basic 05-100186BP		Plan: M3295A2F-0	Two-story SFR with att	2005
New	Approved Basic #05-120010 BP,	2003 IRC,	Plan #M2740A2F-0,	2-story SFR w/ Attchd 2-ci	2005
New	Approved Basic 05-100905BP		2003 IRC	Plan: M2876A2F-0	2005
New	Approved Basic 05-100715BP		2003 IRC	Plan: M3615A3F	2005
New	Approved Basic 05-118783 BP	2003 IRC	Plan: M3438A2F-0	2 story SFR w/attached G	2005
New	Approved Basic 04-121535BP		Plan: M3130A3S-7	Two-story SFR with attacl	2005
New	Approved Basic 05-100619BP		Plan: M3305A4FT-0		2005
New	1992 sq ft Rambler with attached garage				2005
New	Approved basic 05-117307 BP	2003 IRC	Plan# 2195A2F 10	Split entry w/attache	2005
New	Approved basic 05-117307 BP	2003 IRC	Plan# 2195A2F 10	Split entry w/attache	2005
New	Approved Basic 04 -120672 BP			2 story SFRw/attached garage	2005
New	Approved Basic #04-118802			SFR with Attac	2005
New	Approved basic 05-117305 BP	2003 IRC	Plan# 0419-A	2-story sfr w/attached gar	2005
New	Approved basic 05-117305 BP	2003 IRC	Plan# 0419-A	2-story sfr w/attached gar	2005
New	Approved Basic 04-120732BP	SFR with Finished Basement and Attached Garage	2003 IRC		2005
New	Approved basic 05-117305 BP	2003 IRC	Plan# 0419-A	2-story sfr w/attached gar	2005
New	Approved Basic 04 -120672 BP			2 story SFRw/attached garage	2005
New	Approved Basic #04-118802			SFR with Attac	2005
New	Approved Basic 04-120732BP	SFR with Finished Basement and Attached Garage	2003 IRC		2005
New	Rambler style SFR w/attached garage.				2005
New	2 story SFR daylight w/attached garage				2005
New	double wide mobile home				2005
New	Rambler with daylight basement and garage				2005
New	Approved Basic 05-117697BP	2003 IRC	Plan:161-03A	2 story SFR w/attached garag	2005
New	Approved basic 05-124334 BP	2003 IRC	Plan# 2125	2-story sfr w/attached gara	2005
New	Approved basic 05-124334 BP	2003 IRC	Plan# 2125	2-story sfr w/attached gara	2005
New	Approved basic 05-124334 BP	2003 IRC	Plan# 2125	2-story sfr w/attached gara	2005
New	Two story SFR with attached garage				2005
New	Approved Basic 05-101076BP	2003 IRC	Plan:210		2005
New	Rambler style w/finished basement & garage				2005
New	2525 sq ft Rambler with attached garage				2005
New	Approved basic 05-101403 BP	2003 IRC	Plan# 3352-3	2 story sfr w/attached garage	2005
New	Two story SFR with unfinished Basement & attached Garage				2005
New	One-story sfr with garage and unheated storage room above garage (swimming pool 05-116333				2005
New	Approved Basic #05-124117 BP	2003 IRC	2 story SFR w/attached garage	Plan:3101	2005
New	Approved Basic 05-116878BP		2003 IRC	Plan: 3370-3	2005
New	Approved basic 05-101398 BP	2003 IRC	Plan # 3259-3	2 story sfr w/attached garag	2005
New	Approved basic 06-102580 BP	2003 IRC	Plan# 3352-3	Elev B 2 story sfr w/attached g	2005
New	Approved basic 05-101403 BP	2003 IRC	Plan# 3352-3	2 story sfr w/attached garage	2005
New	Approved basic 05-101398 BP	2003 IRC	Plan # 3259-3	2 story sfr w/attached garag	2005

Accessory Dwelling Units

Index # - File Name: 1.0022 - Single Family Dwellings Data\_Snohomish County.pdf

New	Approved	Basic #05-124117 BP	2003 IRC	2 story SFR w/attached garage	Plan:3101	2005
New	Approved	Basic 05-119810 BP	Plan: 3420-3	2003 IRC	2 story SFR w/Attached Garag	2005
New	Approved	Basic 05-116878BP		2003 IRC	Plan: 3370-3	2005
New	Approved	basic 05-101398 BP	2003 IRC	Plan # 3259-3	2 story sfr w/attached garag	2005
New		2-story w/garage	2003 IRC			2005
New	Approved	Basic 05-116878BP		2003 IRC	Plan: 3370-3	2005
New	Approved	basic 05-101404 BP	2003 IRC	Plan # 3324-3	2 story sfr w/attached garage	2005
New	Approved	basic 05-101398 BP	2003 IRC	Plan # 3259-3	2 story sfr w/attached garag	2005
New	Approved	basic 05-101403 BP	2003 IRC	Plan# 3352-3	2 story sfr w/attached garage	2005
New	Approved	Basic 04-119639BP		Plan: Eagle-1	Rambler-style SFR with attach	2005
New	Approved	Basic 04-119641BP		Plan: Skagit B	Two-story SFR with attach	2005
New	Approved	Basic 04-119639BP		Plan: Eagle-1	Rambler-style SFR with attach	2005
New	Approved	Basic 05-101953BP	2003 IRC	2 story SFR w/attached garage	Plan:Rainier	2005
New	Approved	Basic 04-119641BP		Plan: Skagit B	Two-story SFR with attach	2005
New	Approved	Basic 04-115047BP	1 story SFR w/attached garage	2003 IRC	Plan:Eagle 2	2005
New	Approved	Basic 05-116166BP	2003 IRC	Plan: Tyhaka		2005
New	Approved	Basic 04-113768BP	2 story SFR w/attached garage	2003 IRC	Plan:3040	2005
New	Approved	Basic 05-116166BP	2003 IRC	Plan: Tyhaka		2005
New	Approved	Basic 04-119639BP		Plan: Eagle-1	Rambler-style SFR with attach	2005
New	Approved	Basic 04-113768BP	2 story SFR w/attached garage	2003 IRC	Plan:3040	2005
New	Approved	Basic 04-119639BP		Plan: Eagle-1	Rambler-style SFR with attach	2005
New		Two story SFR with attached garage				2005
New	Approved	basic 05-116431 BP	2003 IRC	Plan: 1192	2-story sfr w/attached garag	2005
New	Approved	basic 05-116431 BP	2003 IRC	Plan: 1192	2-story sfr w/attached garag	2005
New	Approved	basic 05-116431 BP	2003 IRC	Plan: 1192	2-story sfr w/attached garag	2005
New	Approved	basic 05-116431 BP	2003 IRC	Plan: 1192	2-story sfr w/attached garag	2005
New	Approved	basic 05-116432 BP	2003 IRC	Plan: 1438	2-story sfr w/attached garage	2005
New	Approved	Basic 04-121430BP	2 story SFR w/attached garage	2003 IRC	Plan:2024	2005
New	Approved	basic 05-116432 BP	2003 IRC	Plan: 1438	2-story sfr w/attached garage	2005
New	Approved	Basic 04-121429BP	2 story SFR w/attached garage	2003 IRC	Plan:1702	2005
New	Approved	basic 05-116431 BP	2003 IRC	Plan: 1192	2-story sfr w/attached garag	2005
New	Approved	basic 05-116432 BP	2003 IRC	Plan: 1438	2-story sfr w/attached garage	2005
New	Approved	Basic 04-121430BP	2 story SFR w/attached garage	2003 IRC	Plan:2024	2005
New	Approved	Basic 04-121429BP	2 story SFR w/attached garage	2003 IRC	Plan:1702	2005
New	Approved	basic 05-116432 BP	2003 IRC	Plan: 1438	2-story sfr w/attached garage	2005
New	Approved	Basic 04-121429BP	2 story SFR w/attached garage	2003 IRC	Plan:1702	2005
New	Approved	basic 05-116431 BP	2003 IRC	Plan: 1192	2-story sfr w/attached garag	2005
New	Approved	Basic 04-121432BP	2 story SFR w/attached garage	2003 IRC	Plan:1904	2005
New	Approved	Basic 04-121431BP	2 story SFr w/attached garage	2003 IRC	Plan:1823	2005
New	Approved	Basic 04-121429BP	2 story SFR w/attached garage	2003 IRC	Plan:1702	2005
New	Approved	Basic 04-121431BP	2 story SFr w/attached garage	2003 IRC	Plan:1823	2005
New	Approved	Basic 04-121429BP	2 story SFR w/attached garage	2003 IRC	Plan:1702	2005
New	Approved	Basic 04-121431BP	2 story SFr w/attached garage	2003 IRC	Plan:1823	2005
New	Approved	Basic 04-121429BP	2 story SFR w/attached garage	2003 IRC	Plan:1702	2005
New	Approved	Basic 04-121431BP	2 story SFr w/attached garage	2003 IRC	Plan:1823	2005
New	Approved	Basic 04-121429BP	2 story SFR w/attached garage	2003 IRC	Plan:1702	2005
New	Approved	Basic 04-121431BP	2 story SFr w/attached garage	2003 IRC	Plan:1823	2005



Accessory Dwelling Units

Index # - File Name: 1.0022 - Single Family Dwellings Data\_Snohomish County.pdf

New	Approved	Basic 04-121429BP	2 story SFR w/attached garage	2003 IRC	Plan:1702	2005
New	Approved	Basic 04-121430BP	2 story SFR w/attached garage	2003 IRC	Plan:2024	2005
New	Approved	Basic 04-121430BP	2 story SFR w/attached garage	2003 IRC	Plan:2024	2005
New	Approved	Basic 04-121432BP	2 story SFR w/attached garage	2003 IRC	Plan:1904	2005
New	Approved	basic 05-116431 BP	2003 IRC	Plan: 1192	2-story sfr w/attached garag	2005
New	Approved	basic 05-116432 BP	2003 IRC	Plan: 1438	2-story sfr w/attached garage	2005
New	Approved	basic 05-116432 BP	2003 IRC	Plan: 1438	2-story sfr w/attached garage	2005
New	Approved	basic 05-116432 BP	2003 IRC	Plan: 1438	2-story sfr w/attached garage	2005
New	Approved	basic 05-116431 BP	2003 IRC	Plan: 1192	2-story sfr w/attached garag	2005
New	Approved	basic 05-116432 BP	2003 IRC	Plan: 1438	2-story sfr w/attached garage	2005
New	Approved	basic 05-116431 BP	2003 IRC	Plan: 1192	2-story sfr w/attached garag	2005
New	Approved	basic 05-116431 BP	2003 IRC	Plan: 1192	2-story sfr w/attached garag	2005
New	Approved	basic 05-116431 BP	2003 IRC	Plan: 1192	2-story sfr w/attached garag	2005
New	Approved	basic 05-116432 BP	2003 IRC	Plan: 1438	2-story sfr w/attached garage	2005
New	Approved	Basic 04-121429BP	2 story SFR w/attached garage	2003 IRC	Plan:1702	2005
New	Approved	basic 05-116431 BP	2003 IRC	Plan: 1192	2-story sfr w/attached garag	2005
New	Approved	basic 05-116431 BP	2003 IRC	Plan: 1192	2-story sfr w/attached garag	2005
New	Approved	basic 05-116432 BP	2003 IRC	Plan: 1438	2-story sfr w/attached garage	2005
New	Approved	Basic 04-121430BP	2 story SFR w/attached garage	2003 IRC	Plan:2024	2005
New	Approved	basic 05-116432 BP	2003 IRC	Plan: 1438	2-story sfr w/attached garage	2005
New	Approved	Basic 04-121429BP	2 story SFR w/attached garage	2003 IRC	Plan:1702	2005
New	Approved	Basic 04-121429BP	2 story SFR w/attached garage	2003 IRC	Plan:1702	2005
New	Approved	basic 05-116432 BP	2003 IRC	Plan: 1438	2-story sfr w/attached garage	2005
New	Approved	basic 05-116431 BP	2003 IRC	Plan: 1192	2-story sfr w/attached garag	2005
New	Approved	basic 05-116432 BP	2003 IRC	Plan: 1438	2-story sfr w/attached garage	2005
New	Approved	Basic 04-121429BP	2 story SFR w/attached garage	2003 IRC	Plan:1702	2005
New	Approved	basic 05-116432 BP	2003 IRC	Plan: 1438	2-story sfr w/attached garage	2005
New	Approved	basic 05-116432 BP	2003 IRC	Plan: 1438	2-story sfr w/attached garage	2005
New	Approved	Basic 04-121432BP	2 story SFR w/attached garage	2003 IRC	Plan:1904	2005
New	Approved	Basic 04-121430BP	2 story SFR w/attached garage	2003 IRC	Plan:2024	2005
New	Approved	Basic 04-121432BP	2 story SFR w/attached garage	2003 IRC	Plan:1904	2005
New	Approved	Basic 05-100640BP	2003 IRC	Plan:Covington 2540		2005
New	Approved	Basic 05-117840BP	2003 IRC	Plan:Nantucket	2 story SFR w/attached g	2005
New	Approved	Basic 05-100640BP	2003 IRC	Plan:Covington 12540		2005
New	Approved	Basic 05-100634BP	2003 IRC	Plan:Rochester 12182		2005
New	Approved	Basic 05-118237-BP	2003 IRC	2 story SFR w/attached garage	Plan: Camde	2005
New	Approved	Basic 05-100640BP	2003 IRC	Plan:Covington 2540		2005
New	Approved	Basic 05-100637 BP	2003 IRC	Plan:Ashford Day 2365		2005
New	Approved	Basic 05-100632BP	2003 IRC	Plan:Quincy Day B		2005
New	Approved	Basic 05-100628BP	2003 IRC	Plan:Quincy Day A		2005
New	Approved	Basic 05-100637BP	2003 IRC	Plan:Ashford Day 2365		2005
New	Approved	Basic 05-101030BP	2003 IRC	Plan:Windsor Day		2005
New	Approved	Basic #04-117193BP		Plan 1859-3 Car Rambler with Attache		2005
New	Approved	Basic 04-116978BP		Plan: 2-1755-3 Two-story SFR with attached ga		2005
New	Approved	Basic #04-115976BP		Rambler with Attached Garage		2005
New	Approved	Basic 04-116978BP		Plan: 2-1755-3 Two-story SFR with attached ga		2005
New	Approved	basic 05-101044 BP	2003 IRC	Plan 1361-2 DLB (2 car)		2005

Accessory Dwelling Units

Index # - File Name: 1.0022 - Single Family Dwellings Data\_Snohomish County.pdf

New	Approved Basic #04-115976BP			Rambler with Attached Garage	2005
New	Approved Basic #04-115978BP			Plan R-2009-3 Two Story SFR with Att	2005
New	Approved Basic #04-115976BP			Rambler with Attached Garage	2005
New	Approved Basic #04-117193BP			Plan 1859-3 Car Rambler with Attache	2005
New	Approved Basic 05-101077BP		2003 IRC	Plan:360	2005
New	Approved Basic 05-117697BP	2003 IRC	Plan:161-03A	2 story SFR w/attached gara	2005
New	Approved Basic 05-116370BP	2003 IRC	Plan:108	2 story SFR w/attached g	2005
New	Approved Basic 05-117703BP	2003 IRC	Plan:350-13A	2 story SFR w/attached garage	2005
New	Approved Basic 05-101076BP		2003 IRC	Plan:210	2005
New	Approved basic 05-124333 BP	2003 IRC	Plan# 1733	2-story sfr w/attached garage	2005
New	Approved basic 05-124337BP	2003 IRC	Plan #1552	2-story sfr w/attached garage	2005
New	Approved basic 05-124337BP	2003 IRC	Plan #1552	2-story sfr w/attached garage	2005
New	Approved basic 05-124332 BP	2003 IRC	Plan# 1763	2-story sfr w/attached gara	2005
New	Approved basic 05-124337BP	2003 IRC	Plan #1552	2-story sfr w/attached garage	2005
New	Approved basic 05-124332 BP	2003 IRC	Plan# 1763	2-story sfr w/attached gara	2005
New	Approved basic 05-124332 BP	2003 IRC	Plan# 1763	2-story sfr w/attached gara	2005
New	Approved basic 05-124332 BP	2003 IRC	Plan# 1763	2-story sfr w/attached gara	2005
New	Approved basic 05-124332 BP	2003 IRC	Plan# 1763	2-story sfr w/attached gara	2005
New	Approved basic 05-124332 BP	2003 IRC	Plan# 1763	2-story sfr w/attached gara	2005
New	Approved basic 05-124332 BP	2003 IRC	Plan# 1763	2-story sfr w/attached gara	2005
New	Approved basic 05-124332 BP	2003 IRC	Plan# 1763	2-story sfr w/attached gara	2005
New	Approved basic 05-124332 BP	2003 IRC	Plan# 1763	2-story sfr w/attached gara	2005
New	Approved basic 05-124332 BP	2003 IRC	Plan# 1763	2-story sfr w/attached gara	2005
New	Approved basic 05-124333 BP	2003 IRC	Plan# 1733	2-story sfr w/attached garage	2005
New	Approved basic 05-124337BP	2003 IRC	Plan #1552	2-story sfr w/attached garage	2005
New	Approved basic 05-124337BP	2003 IRC	Plan #1552	2-story sfr w/attached garage	2005
New	Two-story sfr with garage				2005
New	Approved Basic 05-101022BP		2003 IRC	Plan:5069A	2005
New	Approved basic 05-100212BP			2 story w/attached garage 2003 IRC Plan:50	2005
New	Approved Basic 05-121636BP	2003 IRC		2 story SFR w/attached garage Plan:4055A	2005
New	aPPROVED Basic 05-101022BP		2003 IRC	Plan:5069A	2005
New	Approved Basic 04-117938BP	2 story SFR w/attached garage	2003 IRC	Plan:F5055A	2005
New	Approved basic 05-100212BP			2 story w/attached garage 2003 IRC Plan:50	2005
New	Approved Basic 04-117574BP			Plan: 5060A Two-story SFR with attached gar	2005
New	Approved Basic 05-101022BP		2003 IRC	Plan:5069A	2005
New	Approved Basic 05-116276BP	2003 IRC		Plan: 2870	2005
New	Approved Basic 04-117574BP	2003IRC		Plan: 5060A Two-story SFR with attai	2005
New	2005 Marlette triple wide				2005
New	Approved Basic 05-100166BP			Plan: 35010-A2 Two-story SFR with attach	2005
New	Approved Basic 04-115972BP	2 story SFR w/attached garage	2003 IRC	Plan:4051A	2005
New	Approved Basic 04-117108BP			Plan: 5038 AM Two-story SFR with attached ga	2005
New	Approved Basic 04-116374BP	2 story SFR w/attached garage	2003 IRC	Plan:5055A	2005
New	Approved Basic 05-101022BP		2003 IRC	Plan:5069A	2005
New	Approved Basic 04-118454BP	2 story SFR w/attached garage	2003 IRC	Plan:4855AB	2005
New	Approved Basic 04-117574BP			Plan: 5060A Two-story SFR with attached gar	2005
New	Approved Basic 04-117108BP			Plan: 5038 AM Two-story SFR with attached ga	2005
New	Approved Basic 05-101022BP		2003 IRC	Plan:5069A	2005
New	Approved Basic 04-117574BP			Plan: 5060A Two-story SFR with attached gar	2005
New	Approved Basic 04-118454BP	2 story SFR w/attached garage	2003 IRC	Plan:4855AB	2005

Accessory Dwelling Units

Index # - File Name: 1.0022 - Single Family Dwellings Data\_Snohomish County.pdf

New	Approved Basic 04-120673BP	Plan: 5039 AM	Two-story SFR with 3-car/4	2005
New	Approved Basic 04-117574BP	Plan: 5060A	Two-story SFR with attached gar	2005
New	Approved Basic 04-118454BP	2 story SFR w/attached garage	2003 IRC Plan:4855AB	2005
New	Approved Basic 04-120673BP	Plan: 5039 AM	2story SFR with 3-car/4-car option - 2003 IRC	2005
New	Approved Basic 04-116374BP	2 story SFR w/attached garage	2003 IRC Plan:5055A	2005
New	Approved Basic 04-117574BP	Plan: 5060A	Two-story SFR with attached gar	2005
New	Approved Basic 04-120673BP	Plan: 5039 AM	Two-story SFR with 3-car/4	2005
New	Approved Basic 04-118454BP	2 story SFR w/attached garage	2003 IRC Plan:4855AB	2005
New	Approved Basic 05-121636BP	2003 IRC	2 story SFR w/attached garage Plan:4055A	2005
New	Approved Basic 04-117108BP	Plan: 5038 AM	Two-story SFR with attached ga	2005
New	Approved Basic 04-118454BP	2 story SFR w/attached garage	2003 IRC Plan:4855AB	2005
New	Approved Basic 04-116374BP	2 story SFR w/attached garage	2003 IRC Plan:5055A	2005
New	Approved Basic 05-121636BP	2003 IRC	2 story SFR w/attached garage Plan:4055A	2005
New	Approved Basic 04-116374BP	2 story SFR w/attached garage	2003 IRC Plan:5055A	2005
New	Approved Basic 05-120904BP	2003 IRC	2 story SFRw/attached garage Plan:505	2005
New	Approved Basic 05-120902BP	2003 IRC	2 story SFRw/attached garage Plan:5050A	2005
New	Approved Basic 05-121636BP	2003 IRC	2 story SFR w/attached garage Plan:4055A	2005
New	Approved Basic 04-120673BP	Plan: 5039 AM	Two-story SFR with 3-car/4	2005
New	Approved Basic 04-11669BP	2 story SFR w/attached garage	2003 IRC Plan:4062AB	2005
New	Approved Basic 04-117572BP	Plan 4063	Two-story SFR with attached g	2005
New	Approved Basic 05-101022BP	2003 IRC	Plan:5069A	2005
New	Approved Basic 04-116374BP	2 story SFR w/attached garage	2003 IRC Plan:5055A	2005
New	Approved Basic 04-118454BP	2 story SFR w/attached garage	2003 IRC Plan:4855AB	2005
New	Approved Basic 04-117108BP	Plan: 5038 AM	Two-story SFR with attached ga	2005
New	Approved Basic 04-117574BP	Plan: 5060A	Two-story SFR with attached gar	2005
New	Approved Basic 05-120902BP	2003 IRC	2 story SFRw/attached garage Plan:5050A	2005
New	Approved Basic 04-120673BP	Plan: 5039 AM	Two-story SFR with 3-car/4	2005
New	Approved Basic 04-116374BP	2 story SFR w/attached garage	2003 IRC Plan:5055A	2005
New	Approved Basic 05-120904BP	2003 IRC	2 story SFRw/attached garage Plan:505	2005
New	Approved Basic 04-120673BP	Plan: 5039 AM	Two-story SFR with 3-car/4	2005
New	Approved Basic 04-116374BP	2 story SFR w/attached garage	2003 IRC Plan:5055A	2005
New	Approved Basic 04-118454BP	2 story SFR w/attached garage	2003 IRC Plan:4855AB	2005
New	Approved Basic 04-117574BP	Plan: 5060A	Two-story SFR with attached gar	2005
New	Approved Basic 04-118454BP	2 story SFR w/attached garage	2003 IRC Plan:4855AB	2005
New	Approved Basic 04-120673BP	Plan: 5039 AM	Two-story SFR with 3-car/4	2005
New	Approved Basic 04-116374BP	2 story SFR w/attached garage	2003 IRC Plan:5055A	2005
New	Approved Basic 04-117574BP	Plan: 5060A	Two-story SFR with attached gar	2005
New	Approved Basic 05-101022BP	2003 IRC	Plan:5069A	2005
New	Approved Basic 04-120673BP	Plan: 5039 AM	Two-story SFR with 3-car/4	2005
New	Approved Basic 04-117574BP	Plan: 5060A	Two-story SFR with attached gar	2005
New	Approved Basic 04-116374BP	2 story SFR w/attached garage	2003 IRC Plan:5055A	2005
New	Approved Basic 05-101022BP	2003 IRC	Plan:5069A	2005
New	Approved Basic 04-117574BP	Plan: 5060A	Two-story SFR with attached gar	2005
New	Approved Basic 04-117108BP	Plan: 5038 AM	Two-story SFR with attached ga	2005
New	Approved Basic 04-116374BP	2 story SFR w/attached garage	2003 IRC Plan:5055A	2005
New	Approved Basic 04-120673BP	Plan: 5039 AM	Two-story SFR with 3-car/4	2005
New	Approved Basic 04-117574BP	Plan: 5060A	Two-story SFR with attached gar	2005

Accessory Dwelling Units

Index # - File Name: 1.0022 - Single Family Dwellings Data\_Snohomish County.pdf

New	Approved Basic 04-118454BP	2 story SFR w/attached garage	2003 IRC	Plan:4855AB	2005
New	Approved Basic 05-101022BP		2003 IRC	Plan:5069A	2005
New	Approved Basic 04-116374BP	2 story SFR w/attached garage	2003 IRC	Plan:5055A	2005
New	Approved Basic 04-117574BP		Plan: 5060A	Two-story SFR with attached gar	2005
New	Approved Basic 04-117108BP		Plan: 5038 AM	Two-story SFR with attached ga	2005
New	Approved basic 05-100212BP	2 story w/attached garage	2003 IRC	Plan:50	2005
New	Approved Basic 04-117108BP		Plan: 5038 AM	Two-story SFR with attached ga	2005
New	Approved Basic 04-117574BP		Plan: 5060A	Two-story SFR with attached gar	2005
New	Approved Basic 04-117938BP	2 story SFR w/attached garage	2003 IRC	Plan:F5055A	2005
New	Approved Basic 04-120673BP		Plan: 5039 AM	Two-story SFR with 3-car/4	2005
New	Double wide MH				2005
New	Approved Basic 04 120975 BP			2 story SFRw/attached garage	2005
New	Approved Basic 04 120975 BP			2 story SFRw/attached garage	2005
New	Approved basic 05- 100689		Plan: 474-2-3	2 story single family - 2003 IRC	2005
New	Approved basic 05- 100689BP	2003 IRC		Plan: 474-2-3 2 story single family	2005
New	Approved basic 05-100689BP	2003 IRC		Plan: 474-2-3 2 story single family	2005
New	Approved Basic 04 120975 BP			2 story SFRw/attached garage	2005
New	Approved basic 05-100694 BP	2003 IRC		Plan: 475-3 2 story SFR w/attached gara	2005
New	Approved Basic 04 120975 BP			2 story SFRw/attached garage	2005
New	Approved basic #05-100246 BP		2003 IRC	Plan:M2960A3FT-12	2-story
New	2 story SFR w/attached garage	2003 IRC	Plan:2823		2005
New	Approved Basic 04-117034BP	2 story SFR w/attached garage	2003 IRC	Plan:2590C	2005
New	Two Story SFR with Attached Garage		2003 IRC		2005
New	2-Story SFR w/attached garage				2005
New	Approved basic #05-100246 BP		2003 IRC	Plan:M2960A3FT-12	2-story
New	Two-story SFR with attached garage -	2003 IRC			2005
New	Two-story SFR with attached garage -	2003 IRC			2005
New	Two-story SFR with attached 4-car tandem garage -	2003 IRC			2005
New	Approved Basic 04-114805 BP		Plan 50010-A3	Two-story SFR - 2003 IRC	2005
New	Approved Basic 04-114805 BP		Plan 50010-A3	Two-story SFR - 2003 IRC	2005
New	Approved Basic 05-100166BP		Plan: 35010-A2	Two-story SFR with attach	2005
New	Approved Basic 04-114805 BP		Plan 50010-A3	Two-story SFR - 2003 IRC	2005
New	Approved Basic 04-114805 BP		Plan 50010-A3	Two-story SFR - 2003 IRC	2005
New	Approved Basic 04-114805 BP		Plan 50010-A3	Two-story SFR - 2003 IRC	2005
New	Two story SFR with attached garage				2005
New	Approved Basic 04-117295BP	2 story SFR w/attached garage	2003 IRC	Plan:50030-A2	2005
New	Approved Basic 05-100164BP	2003 IRC		Plan: 40040-A2S	Two-story SFR w
New	Approved Basic 04-117194BP	2003 IRC	Plan:50040-A2	2 story SFR w/attached garage	2005
New	Approved Basic 05-100164BP	2003 IRC		Plan: 40040-A2S	Two-story SFR w
New	Approved Basic 04-117194BP	2 story SFR w/attached garage	2003 IRC	Plan:50040-A2	2005
New	Approved Basic 05-100164BP	2003 IRC		Plan: 40040-A2S	Two-story SFR wi
New	Approved Basic 04-117295BP	2 story SFR w/attached garage	2003 IRC	Plan:50030-A2	2005
New	Approved Basic 04-117194BP	2 story SFR w/attached garage	2003 IRC	Plan:50040-A2	2005
New	Approved Basic 05-122327BP	2003 IRC		2 story SFR w/attached garage	Plan:3042B
New	Approved Basic 04-121745BP	2 Story SFR w/attached garage	2003 IRC	Plan:4040AB	2005
New	Approved basic 05-101956 BP	2003 IRC	Plan: 4044ABC	2 story w/attached garage	2005
New	Approved Basic 05-122327BP	2003 IRC		2 story SFR w/attached garage	Plan:3042B

Accessory Dwelling Units

Index # - File Name: 1.0022 - Single Family Dwellings Data\_Snohomish County.pdf

New	Approved	Basic 04-121596BP	2 Story SFR w/attached garage	2003 IRC	Plan:4044ABC	2005
New	Approved	Basic 04-121745BP	2 Story SFR w/attached garage	2003 IRC	Plan:4040AB	2005
New	Approved	Basic 04-121745BP	2003 IRC	Plan:4040AB	2 Story SFR w/at	2005
New	Approved	Basic 05-117610BP	2003 IRC	Plan:3840 ABC		2005
New	Approved	Basic 05-117609BP	2003 IRC	Plan:3840 B		2005
New	Approved	Basic 04-121596BP	2 Story SFR w/attached garage	2003 IRC	Plan:4044ABC	2005
New			Two story SFR with attached Garage			2005
New	Approved	Basic 04-11669BP	2 story SFR w/attached garage	2003 IRC	Plan:4062AB	2005
New	Approved	Basic 04-121305BP	2 story SFR w/attached garage	2003 IRC	Plan:3060AB	2005
New	Approved	Basic 04-118859BP	2 story SFR w/attached garage	2003 IRC	Plan:4063AB	2005
New	Approved	Basic 04-11669BP	2 story SFR w/attached garage	2003 IRC	Plan:4062AB	2005
New	Approved	Basic 05-121636BP	2003 IRC	2 story SFR w/attached garage	Plan:4055/	2005
New	Approved	Basic 05-116596BP	2003 IRC	Plan:3840 A		2005
New	Approved	basic 05-101956 BP	2003 IRC	Plan: 4044ABC	2 story w/attached garage	2005
New	Approved	Basic 05-117609BP	2003 IRC	Plan:3840 B		2005
New	Approved	basic 05-101956 BP	2003 IRC	Plan: 4044ABC	2 story w/attached garage	2005
New	Approved	Basic 04-11669BP	2 story SFR w/attached garage	2003 IRC	Plan:4062AB	2005
New	Approved	Basic 05-117610BP	2003 IRC	Plan:3840 ABC		2005
New	Approved	Basic 04-121596BP	2 Story SFR w/attached garage	2003 IRC	Plan:4044ABC	2005
New	Approved	Basic 05-116869BP	2003 IRC	Plan:7032AB		2005
New	Approved	Basic 04-118856BP	2 story SFR w/attached garage	2003 IRC	Plan:3062AB	2005
New	Approved	Basic 04-121305BP	2 story SFR w/attached garage	2003 IRC	Plan:3060AB	2005
New	Approved	Basic 04-118856BP	2 story SFR w/attached garage	2003 IRC	Plan:3062AB	2005
New	Approved	Basic 05-116869BP	2003 IRC	Plan:7032AB		2005
New	Approved	Basic 05-116869BP	2003 IRC	Plan:7032AB		2005
New	Approved	Basic 04-118856BP	2 story SFR w/attached garage	2003 IRC	Plan:3062AB	2005
New	Approved	Basic 04-121305BP	2 story SFR w/attached garage	2003 IRC	Plan:3060AB	2005
New	Approved	Basic 04-118856BP	2 story SFR w/attached garage	2003 IRC	Plan:3062AB	2005
New	Approved	Basic 04-121596BP	2 Story SFR w/attached garage	2003 IRC	Plan:4044ABC	2005
New	Approved	Basic 05-116869BP	2003 IRC	Plan:7032AB		2005
New	Approved	Basic 04-121745BP	2003 IRC	Plan:4040AB	2 Story SFR w/att	2005
New	Approved	Basic 04-118858BP	2 story SFR w/attached garage	2003 IRC	Plan:4062AB	2005
New	Approved	Basic 05-117610BP	2003 IRC	Plan:3840 ABC		2005
New	Approved	Basic 04-121745BP	2003 IRC	Plan:4040AB	2 Story SFR w/att	2005
New	Approved	basic 05-101956 BP	2003 IRC	Plan: 4044ABC	2 story w/attached garage	2005
New	Approved	basic 05-101956 BP	2003 IRC	Plan: 4044ABC	2 story w/attached garage	2005
New	Approved	Basic 04-11669BP	2 story SFR w/attached garage	2003 IRC	Plan:4062AB	2005
New	Approved	Basic 04-118859BP	2 story SFR w/attached garage	2003 IRC	Plan:4063AB	2005
New	Approved	Basic 04-121305BP	2 story SFR w/attached garage	2003 IRC	Plan:3060AB	2005
New	Approved	Basic 05-121637BP	2003 IRC	2 story SFR w/attached garage	Plan:4055B	2005
New	Approved	basic 05-101956 BP	2003 IRC	Plan: 4044ABC	2 story w/attached garage	2005
New	Approved	basic 05-121434 BP	2003 IRC	Plan# 3052A	2-story sfr w/attached garage	2005
New	Approved	Basic 04-121596BP	2 Story SFR w/attached garage	2003 IRC	Plan:4044ABC	2005
New	Approved	Basic 04-121745BP	2 Story SFR w/attached garage	2003 IRC	Plan:4040AB	2005
New	Approved	Basic 04-121596BP	2003 IRC	Plan:4044ABC		2005
New	Approved	basic 05-121435 BP	2003 IRC	Plan# 3052B	2-story sfr w/attached garage	2005
New	Approved	Basic 04-121745BP	2 Story SFR w/attached garage	2003 IRC	Plan:4040AB	2005

Accessory Dwelling Units

Index # - File Name: 1.0022 - Single Family Dwellings Data\_Snohomish County.pdf

New	Approved Basic 05-117610BP		2003 IRC	Plan:3840 ABC	2005
New	Approved Basic 04-118856BP	2 story SFR w/attached garage	2003 IRC	Plan:3062AB	2005
New	Approved basic 05-101958BP		2003 IRC	Plan: 3063A 2 story w/attached garage	2005
New	Approved Basic 04-121305BP	2 story SFR w/attached garage	2003 IRC	Plan:3060AB	2005
New	Approved basic 05-121434 BP		2003 IRC	Plan# 3052A 2-story sfr w/attached garage	2005
New	Approved Basic 04-121305BP	2 story SFR w/attached garage	2003 IRC	Plan:3060AB	2005
New	Approved Basic 04-121305BP	2 story SFR w/attached garage	2003 IRC	Plan:3060AB	2005
New	Two-story Duplex with attached garages - 2003 IRC				2005
New	Approved Basic 05-100687BP		2003 IRC	Plan: 2112 A&B	2005
New	Approved Basic 05-100687BP		2003 IRC	Plan: 2112 A&B	2005
New	Approved Basic 04-114926BP	2 story SFR w/attached garage	2003 IRC	Plan 2451A & B	2005
New	Approved Basic 04-111506BP		Plan: 2863-C	Two-story SFR - 2003 IRC	2005
New	Approved Basic 04-116177BP		Builders plan# 2575-A&B	2-Story SFR w/atta	2005
New	Approved Basic 05-100213BP		2003 IRC	Plan: 2640 A & B Two-story SFR wit	2005
New	Approved Basic 05-100213BP		2003 IRC	Plan: 2640 A & B Two-story SFR wit	2005
New	Approved Basic 04-114926BP	2 story SFR w/attached garage	2003 IRC	Plan 2451A & B	2005
New	Approved Basic 04-116177BP		Builders plan# 2575-A&B	2-Story SFR w/atta	2005
New	Approved Basic 04-111502BP		Plan 2863-A	Two-story SFR - 2003 IR	2005
New	Approved Basic 04-116177BP		Builders plan# 2575-A&B	2-Story SFR w/atta	2005
New	Approved Basic 04-111511BP		Plan 3387-B	Two-story SFR - 2003 IRC	2005
New	Approved Basic 05-100399BP	2 story SFR w/attached garage	2003 IRC	Plan:2996C	2005
New	Approved Basic 05-101298BP		2003 IRC	Plan:2958	2005
New	Rambler style Duplex w/garage				2005
New	Rambler style duplex with attached garage - 2003 IRC				2005
New	Split-level entry SFR - 2003 IRC				2005
New	Two-story SFR with attached garage - 2003 IRC				2005
New	2-story SFR w/garage				2005
New	Approved basic 05-118810 BP		2003 IRC	Plan# 2112 A&B 3 - car 2 - story SFR w/a	2005
New	Approved Basic 05-118004 BP	2003 IRC	Plan: 2451A/B 3 car	2-story sfr w/attached ga	2005
New	Approved Basic 04-111508BP		Plan 3387-C	Two-story SFR - 2003 IRC	2005
New	Approved Basic 05-100687BP		2003 IRC	Plan: 2112 A&B	2005
New	Approved 05-100692BP		2003 IRC	Plan: 3192B-3car	2005
New	Approved basic 05-124271 BP		2003 IRC	Plan# 2863B 3-car 2-story sfr w/attache	2005
New	Approved basic 05-116239BP		2003 IRC	Plan: 2863C-3 car 2 story sfr w/attached }	2005
New	Approved basic 05-124271 BP		2003 IRC	Plan# 2863B 3-car 2-story sfr w/attache	2005
New	Approved Basic 04-111506BP		Plan: 2863-C	Two-story SFR - 2003 IRC	2005
New	Approved Basic 05-100213BP		2003 IRC	Plan: 2640 A & B Two-story SFR	2005
New	Approved Basic 04-111508BP		Plan 3387-C	Two-story SFR - 2003 IRC	2005
New	Approved Basic 04-111510BP		Plan 3387-A	Two-story SFR - 2003 IRC	2005
New	Approved Basic 05-100213BP		2003 IRC	Plan: 2640 A & B Two-story SFR wit	2005
New	Approved Basic 05-100213BP		2003 IRC	Plan: 2640 A & B Two-story SFR wit	2005
New	Approved Basic 04-116177BP		Builders plan# 2575-A&B	2-Story SFR w/atta	2005
New	Approved Basic 04-116177BP		Builders plan# 2575-A&B	2-Story SFR w/atta	2005
New	Approved Basic 04-116427BP		Plan: 3512 A & B	Two-story SFR with attach	2005
New	Approved Basic 04-113874PB	Two Story SFR w/attached 2 Car Garage	2003 IRC	Builder	2005
New	Approved Basic 04-111510BP		Plan 3387-A	Two-story SFR - 2003 IRC	2005
New	Approved Basic 04-111511BP		Plan 3387-B	Two-story SFR - 2003 IRC	2005

Accessory Dwelling Units

Index # - File Name: 1.0022 - Single Family Dwellings Data\_Snohomish County.pdf

New	Approved Basic 04-116177BP		Builders plan# 2575-A&B	2-Story SFR w/atta	2005
New	Approved Basic 04-111506BP		Plan: 2863-C	Two-story SFR - 2003 IRC	2005
New	Approved Basic 05-100213BP	2003 IRC	Plan: 2640 A & B	Two-story SFR wit	2005
New	Approved Basic 04-111510BP		Plan 3387-A	Two-story SFR - 2003 IRC	2005
New	Approved Basic 04-113874PB	Two Story SFR w/attached 2 Car Garage	2003 IRC	Builder	2005
New	Approved Basic 04-112274BP	2 story SFR w/ attached garage	2003 IRC	Plan#2205 A & B	2005
New	Approved Basic 04-111508BP		Plan 3387-C	Two-story SFR - 2003 IRC	2005
New	Approved Basic 04-114574BP	2 story SFRw/attached garage	2003 IRC	Plan:1861	2005
New	Approved Basic 04-118514BP	2 story SFR w/attached garage	2003 IRC	Plan:2068	2005
New	Approved Basic 04-114578BP	2 story SFR w/attached garage	2003 IRC	Plan:2978	2005
New	Approved Basic 04-114578BP	2 story SFR w/attached garage	2003 IRC	Plan:2978	2005
New	Approved Basic 04-115241BP		Plan: 2473	Two-story SFR - 2003 IRC	2005
New	Approved Basic 04-118514BP	2 story SFR w/attached garage	2003 IRC	Plan:2068	2005
New	Approved Basic 04-115241BP		Plan: 2473	Two-story SFR - 2003 IRC	2005
New	Approved Basic 04-115238BP		Plan: 2201	Two-story SFR - 2003 IRC	2005
New	Approved Basic 04-120674BP	2 story SFR w/attached garage	2003 IRC	Plan:2440	2005
New	Approved Basic 04-115241BP		Plan: 2473	Two-story SFR - 2003 IRC	2005
New	Approved Basic 04-114578BP	2 story SFR w/attached garage	2003 IRC	Plan:2978	2005
New	Approved Basic 04-116177BP		Builders plan# 2575-A&B	2-Story SFR w/atta	2005
New	Approved Basic 04-114926BP	2 story SFR w/attached garage	2003 IRC	Plan 2451A & B	2005
New	Approved Basic 05-100687BP		2003 IRC	Plan: 2112 A&B	2005
New	Approved Basic 05-100687BP		2003 IRC	Plan: 2112 A&B	2005
New	Approved Basic 04-114926BP	2 story SFR w/attached garage	2003 IRC	Plan 2451A & B	2005
New	Approved basic 05-127356 BP	2003 IRC	Plan# 2306 A&B	2-story sfr w/attache	2005
New	Approved Basic 04-116177BP		Builders plan# 2575-A&B	2-Story SFR w/atta	2005
New	Approved Basic 04-116177BP		Builders plan# 2575-A&B	2-Story SFR w/atta	2005
New	Approved Basic 04-114926BP	2 story SFR w/attached garage	2003 IRC	Plan 2451A & B	2005
New	Approved Basic 04-116177BP		Builders plan# 2575-A&B	2-Story SFR w/atta	2005
New	Approved Basic 04-111502BP		Plan 2863-A	Two-story SFR - 2003 IR	2005
New	Approved Basic 04-113874PB	Two Story SFR w/attached 2 Car Garage	2003 IRC	Builder	2005
New	Approved Basic 04-112274BP	2 story SFR w/ attached garage	2003 IRC	Plan#2205 A & B	2005
New	Approved basic 05-127356 BP	2003 IRC	Plan# 2306 A&B	2-story sfr w/attached gar	2005
New	Approved Basic 04-111510BP		Plan 3387-A	Two-story SFR - 2003 IRC	2005
New	Approved Basic 04-111506BP		Plan: 2863-C	Two-story SFR - 2003 IRC	2005
New	Approved Basic 04-111511BP		Plan 3387-B	Two-story SFR - 2003 IRC	2005
New	1888 sq ft Rambler				2005
New	Approved Basic 05-101953BP	2003 IRC	2 story SFR w/attached garage	Plan:Rainier	2005
New	Reversed expire status to allow for a final inspection per A. Husby 7/19/13 dm			Expired without	2005
New	Approved Basic 04-118859BP	2 story SFR w/attached garage	2003 IRC	Plan:4063AB	2005
New	Approved Basic 04-121745BP	2 Story SFR w/attached garage	2003 IRC	Plan:4040AB	2005
New	Approved Basic 04-101956BP	2 Story SFR w/attached garage	2003 IRC	Plan:4044ABC	2005
New	Approved basic 05-121434 BP	2003 IRC	Plan# 3052A	2-story sfr w/attached garage	2005
New	Approved basic 05-121435 BP	2003 IRC	Plan# 3052B	2-story sfr w/attached garage	2005
New	Approved Basic 04-120907BP	2 stroy SFR w/attached garage	2003 IRC	Plan:2140B	2005
New	Approved Basic 04-120906BP	2 story SFR w/attached garage	2003 IRC	Plan:2140A	2005
New	Approved Basic 04-120907BP	2 stroy SFR w/attached garage	2003 IRC	Plan:2140B	2005
New	Approved Basic 04-120906BP	2 story SFR w/attached garage	2003 IRC	Plan:2140A	2005

Accessory Dwelling Units

Index # - File Name: 1.0022 - Single Family Dwellings Data\_Snohomish County.pdf

New	Approved Basic 04-120907BP	2 stroy SFR w/attached garage	2003 IRC	Plan:2140B	2005
New	Approved Basic 04-120905BP	2 story SFR w/attached garage	2003 IRC	Plan:2598	2005
New	Approved Basic 04-120905BP	2 story SFR w/attached garage	2003 IRC	Plan:2598	2005
New	Approved Basic 04-120905BP	2 story SFR w/attached garage	2003 IRC	Plan:2598	2005
New	Approved Basic 04-120912BP	2 story SFR w/attached garage	2003 IRC	Plan:2409B	2005
New	Approved Basic 04-120905BP	2 story SFR w/attached garage	2003 IRC	Plan:2598	2005
New	Approved Basic 04-120907BP	2 story SFR w/attached garage	2003 IRC	Plan:2140B	2005
New	Approved Basic 05-100004BP	2 story SFR w/attached garage	2003 IRC	Plan:2042B	2005
New	Approved Basic 04-120910BP	2 story SFR w/attached garage	2003 IRC	Plan:2409A	2005
New	Approved Basic 04-120906BP	2 story SFR w/attached garage	2003 IRC	Plan:2140A	2005
New	Approved Basic 05-100006BP	2003 IRC Plan:2472A	2 story SFR w/attached garage		2005
New	Approved Basic 05-100004BP	2 story SFR w/attached garage	2003 IRC	Plan:2042B	2005
New	Approved Basic 05-100006BP	2003 IRC Plan:2472A	2 story SFR w/attached garage		2005
New	Approved Basic 04-120912BP	2 story SFR w/attached garage	2003 IRC	Plan:2409B	2005
New	Approved Basic 04-120909BP	2 story SFR w/attached garage	2003 IRC	Plan:2042C	2005
New	Approved Basic 05-100008BP	2 story SFR w/attached garage	2003 IRC	Plan:2472B	2005
New	Approved Basic 04-120910BP	2 story SFR w/attached garage	2003 IRC	Plan:2409A	2005
New	Approved Basic 05-100004BP	2 story SFR w/attached garage	2003 IRC	Plan:2042B	2005
New	Approved Basic 04-120908BP	2 story SFR w/attached garage	2003 IRC	Plan:2140C	2005
New	Approved Basic 04-120905BP	2 story SFR w/attached garage	2003 IRC	Plan:2598	2005
New	Approved Basic 04-120912BP	2 story SFR w/attached garage	2003 IRC	Plan:2409B	2005
New	Approved Basic 05-100006BP	2003 IRC Plan:2472A	2 story SFR w/attached garage		2005
New	Approved Basic 04-120905BP	2 story SFR w/attached garage	2003 IRC	Plan:2598	2005
New	Approved Basic 05-100008BP	2 story SFR w/attached garage	2003 IRC	Plan:2472B	2005
New	Approved Basic 05-100006BP	2003 IRC Plan:2472A	2 story SFR w/attached garage		2005
New	Approved Basic 05-100008BP	2 story SFR w/attached garage	2003 IRC	Plan:2472B	2005
New	Approved Basic 05-100006BP	2003 IRC Plan:2472A	2 story SFR w/attached garage		2005
New	Approved Basic 05-100008BP	2 story SFR w/attached garage	2003 IRC	Plan:2472B	2005
New	Approved Basic 05-100006BP	2003 IRC Plan:2472A	2 story SFR w/attached garage		2005
New	Approved Basic 04-120906BP	2 story SFR w/attached garage	2003 IRC	Plan:2140A	2005
New	3 story SFR w/ attchd. 3 car garage				2005
New	Two story SFR with attached garage				2005
New	2114 sf rambler with attached garage				2005
New	One-story SFR w/finished basement				2005
New	Approved Basic 04-118812BP	SFR w/attached garage	2003 IRC	Plan:F	2005
New	Approved Basic 04-121427 BP	2003 IRC	Plan:Elevations	Rambler style w/attach	2005
New	Approved Basic 04-121423 BP	2003 IRC	Plan C - Starlite Point	2-story w/attache	2005
New	Approved Basic 04-118819BP	2 story SFR w/attached garage	2003 IRC	Plan:C4	2005
New	Approved Basic 04-121427 BP	2003 IRC	Plan:Elevations	Rambler style w/attach	2005
New	Approved Basic 04-118822BP	2 story SFR w/attached garage	2003 IRC	Plan: Rose 8	2005
New	Approved Basic 04-121423 BP	plan C - Starlite Point	2-story w/attached garage		2005
New	Approved Basic 04-121423 BP	2003 IRC	Plan C - Starlite Point	2-story w/attache	2005
New	Approved Basic 04-121423 BP	2003 IRC	Plan C - Starlite Point	2-story w/attache	2005
New	Approved Basic 04-118822BP	2 story SFR w/attached garage	2003 IRC	Plan: Rose 8	2005
New	Approved Basic 04-121423 BP	2003 IRC	Plan C - Starlite Point	2-story w/attache	2005
New	Approved Basic 04-121428 BP	Rambler style w/attached garage	2003 IRC		2005
New	Approved Basic 04-118812BP	SFR w/attached garage	2003 IRC	Plan:F	2005



Accessory Dwelling Units

Index # - File Name: 1.0022 - Single Family Dwellings Data\_Snohomish County.pdf

New	Approved Basic 04-121428 BP		Rambler style w/attached garage	2003 IRC		2005
New	Approved Basic 04-118822BP	2 story SFR w/attached garage	2003 IRC	Plan: Rose 8		2005
New	Approved Basic 04-121428 BP		Rambler style w/attached garage	2003 IRC		2005
New	Approved Basic 04-121423 BP		plan C - Starlite Point	2-story w/attached garage		2005
New	Two-story SFR			Builders Plan: 3402-A		2005
New	Two-story SFR			Builders Plan: 3402-B		2005
New	Approved basic 05-101398 BP	2003 IRC	Plan # 3259-3	2 story sfr w/attached garag		2005
New	Approved basic 05-101403 BP	2003 IRC	Plan# 3352-3	2 story sfr w/attached garage		2005
New	Two-story sfr with garage.					2005
New	Approved basic 05-101398 BP	2003 IRC	Plan # 3259-3	2 story sfr w/attached garag		2005
New	Approved Basic 05-116878BP		2003 IRC	Plan: 3370-3		2005
New	2 story SFR w/ attchd. 3 car garage					2005
New	Approved Basic 05-116878BP		2003 IRC	Plan: 3370-3		2005
New	Approved Basic 05-116878BP		2003 IRC	Plan: 3370-3		2005
New	Approved Basic 04-113768BP	2 story SFR w/attached garage	2003 IRC	Plan:3040		2005
New	Approved basic 05-116351 BP	2003 IRC	Plan: 2130	2-story SFR w/attached garag		2005
New	Approved Basic 05-100400BP	2 story SFR w/attached garage	2003 IRC	Plan:2952		2005
New	Approved Basic 05-116844 BP	2003 IRC		Plan #3313		2005
New	Approved Basic 05-116844BP	2003 IRC		Plan #3313		2005
New	2-story sfr w/attached garage					2005
New	2-story sfr w/attached garage					2005
New	Approved Basic 05-117566 BP	2003 IRC	Plan#3024 A	2-story SFR w/attached gara		2005
New	Approved Basic 05-119062	2003 IRC	2 story SFR w/attached garage	Plan: 3024B		2005
New	Approved Basic 05-117566 BP	2003 IRC	Plan#3024 A	2-story SFR w/attached gara		2005
New	Approved Basic 05-119062BP	2003 IRC	2 story SFR w/attached garage	Plan:3024B		2005
New	2-story sfr w/attached garage					2005
New	2-Story SFR w/attached garage					2005
New	2-Story SFR w/attached garage.					2005
New	2-Story SFR w/attached garage.					2005
New	Rambler w/ 3 car garage					2005
New	Approved Basic 05-101130BP	2003 IRC		Plan:2812		2005
New	Approved Basic 05-101827 BP	2003 IRC		Plan: 2591-3	Two Story SFR w	2005
New	Approved Basic 05-101130BP	2003 IRC		Plan:2812		2005
New	Approved Basic 05-101130BP	2003 IRC		Plan:2812		2005
New	Approved Basic 05-101129BP		2003 IRC	Plan:2819	2 story single family with	2005
New	Approved Basic 05-101130BP	2003 IRC		Plan:2812		2005
New	Approved Basic 05-117652BP	2003 IRC	Plan: 2612	2 story W/ attached garage		2005
New	Approved Basic 05-101130BP	2003 IRC		Plan:2812		2005
New	Approved Basic 05-117652BP	2003 IRC	Plan: 2612	2 story SFR w/attached garag		2005
New	2-story sfr w/attached garage					2005
New	2 story Duplex					2005
New	Two-story SFR with attached garage					2005
New	Two-story SFR with attached garage					2005
New	Two-story SFR with attached garage - 2003 IRC			Plan: 2559		2005
New	Approved Basic 05-127365BP	2003 IRC	2 story SFR w/attached garage	Plan:3131A & I		2005
New	Approved Basic 04-116493BP			Plan: 2421 C	Two-story SFR with attached	2005
New	Approved Basic 05-126842BP	2003 IRC	2 story SFR w/attached garage	Plan:2521A & I		2005

Accessory Dwelling Units

Index # - File Name: 1.0022 - Single Family Dwellings Data\_Snohomish County.pdf

New	Approved	Basic 05-127999BP	2003 IRC	2 story SFR w/attached garage	Plan:3411C	2005
New	Approved	Basic 05-121242BP	2003 IRC	2 story SFR w/attached garage	Plan:3641C	2005
New	Approved	Basic 04-116513BP		Plan: 2421 A & B Two-story SFR with atta		2005
New	Approved	Basic 05-126842BP	2003 IRC	2 story SFR w/attached garage	Plan:2521A	2005
New	Approved	Basic 05-126340BP	2003 IRC	2 story SFR w/attached garage	Plan:31265A	2005
New	Approved	Basic 05-119426BP	2003 IRC	2 story SFR w/attached garage	Plan:2441	2005
New	Approved	Basic #04-109118 BP		Plan: 2511 C Two Story SFR - 1997 UBC		2005
New	Approved	Basic 05-126847BP	2003 IRC	2 story SFR w/attached garage	Plan:3175B	2005
New	Approved	Basic 05-123442BP	2003 IRC	2 story SFR w/attached garage	Plan:3531C	2005
New	Approved	Basic 04-117263BP	2 story SFR w/attached garage	2003 IRC	Plan:3131B	2005
New	Approved	Basic 05-123446BP	2003 IRC	2 story SFR w/attached garage	Plan:3611C	2005
New	Approved	Basic 04-116513BP		Plan: 2421 A & B Two-story SFR with atta		2005
New	Approved	Basic 04-116493BP		Plan: 2421 C Two-story SFR with attached		2005
New	Approved	Basic 04-121383BP	2 story SFR w/attached garage	2003 IRC	Plan:3121B	2005
New	Approved	Basic 04-116513BP		Plan: 2421 A & B Two-story SFR with atta		2005
New	Approved	Basic 05-123446BP	2003 IRC	2 story SFR w/attached garage	Plan:3611C	2005
New	Approved	Basic 04-116493BP		Plan: 2421 C Two-story SFR with attached		2005
New	Approved	Basic 05-119426BP	2003 IRC	2 story SFR w/attached garage	Plan:2441	2005
New	Approved	Basic 05-128002BP	2003 IRC	2 story SFR w/attached garage	Plan:2841C	2005
New	Approved	Basic 05-121242BP	2003 IRC	2 story SFR w/attached garage	Plan:3641C	2005
New	Approved	Basic 05-101912BP	2003 IRC		Plan:2234A	2005
New	Approved	Basic 05-101917BP	2003 IRC		Plan:2742B	2005
New	Approved	Basic 05-101918BP	2003 IRC		Plan:2742A	2005
New	Approved	Basic 05-101916BP	2003 IRC		Plan:2994A	2005
New	Approved	Basic 05-101914BP	2003 IRC		Plan:2530A	2005
New	Approved	Basic 05-101918BP	2003 IRC		Plan:2742A	2005
New	Approved	Basic 05-101912BP	2003 IRC		Plan:2234A	2005
New	Approved	Basic 05-101919BP	2003 IRC		Plan:2595B	2005
New	Approved	Basic 05-101912BP	2003 IRC		Plan:2234A	2005
New	Approved	Basic 05-101912BP	2003 IRC		Plan:2234A	2005
New	Approved	Basic 05-101914BP	2003 IRC		Plan:2530A	2005
New	Approved	Basic 05-101914BP	2003 IRC		Plan:2530A	2005
New	Approved	Basic 05-101920BP	2003 IRC		Plan:2595A	2005
New	Approved	Basic 05-101918BP	2003 IRC		Plan:2742A	2005
New	Approved	Basic 05-118924BP	2003 IRC	2 story SFR w/attached garage	Plan:2621C	2005
New	Approved	Basic 05-122161 BP	2003 IRC	Plan# 3131C 2 - story sfr w/attached ga		2005
New	Approved	Basic 04-117263BP	2 story SFR w/attached garage	2003 IRC	Plan:3131B	2005
New	Approved	Basic 04- 115883BP		Builders Plan #2431C 2 Story w/ 2 Car Garage		2005
New	Approved	Basic 04-116513BP		Plan: 2421 A & B Two-story SFR with atta		2005
New	Approved	Basic 04-117263BP	2 story SFR w/attached garage	2003 IRC	Plan:3131B	2005
New	Approved	Basic 05-126842BP	2003 IRC	2 story SFR w/attached garage	Plan: 2521A	2005
New	Approved	Basic 05-127365BP	2003 IRC	2 story SFR w/attached garage	Plan:3131A &	2005
New	Approved	Basic 05-127684BP BP	2003 IRC	2 story SFR w/attached garage	Plan: 32	2005
New	Approved	Basic 05-121678BP	2003 IRC	2 story SFR w/attached garage	Plan:241	2005
New	Approved	Basic 05-123185BP	2003 IRC	2 story Sfr w/attached garage	Plan:2611C	2005
New	Approved	Basic 05-101914BP	2003 IRC		Plan:2530A	2005
New	Approved	Basic 05-101912BP	2003 IRC		Plan:2234A	2005

Accessory Dwelling Units

Index # - File Name: 1.0022 - Single Family Dwellings Data\_Snohomish County.pdf

New	Approved Basic 05-101919BP		2003 IRC	Plan:2595B	2005
New	Approved Basic 05-101917BP		2003 IRC	Plan:2742B	2005
New	Approved Basic 05-101912BP		2003 IRC	Plan:2234A	2005
New	Approved Basic 04-120626BP	2 story SFR w/attached garage	2003 IRC	Plan:2209	2005
New	Approved Basic 05-101920BP		2003 IRC	Plan:2595A	2005
New	Approved Basic 05- 101915BP		2003 IRC	Plan:2994B	2005
New	Approved Basic 05-101912BP		2003 IRC	Plan:2234A	2005
New	Approved Basic 05- 101915BP		2003 IRC	Plan:2994B	2005
New	Approved Basic 05-101912BP		2003 IRC	Plan:2234A	2005
New	Approved Basic 05- 101915BP		2003 IRC	Plan:2994B	2005
New	Approved Basic 05-101909BP		2003 IRC	Plan:2234B	2005
New	Approved Basic 05-101919BP		2003 IRC	Plan:2595B	2005
New	Approved Basic 05-101914BP		2003 IRC	Plan:2530A	2005
New	Approved Basic 05-101913BP		2003 IRC	Plan:2530B	2005
New	Approved Basic 05-101920BP		2003 IRC	Plan:2595A	2005
New	Approved Basic 05-101917BP		2003 IRC	Plan:2742B	2005
New	Approved Basic 05-101912BP		2003 IRC	Plan:2234A	2005
New	Approved Basic 05- 101915BP		2003 IRC	Plan:2994B	2005
New	Approved Basic 05-101920BP		2003 IRC	Plan:2595A	2005
New	Approved Basic 05-101912BP		2003 IRC	Plan:2234A	2005
New	Approved Basic 05-101913BP		2003 IRC	Plan:2530B	2005
New	Rambler style SFR w/attached garage.				2005
New	Approved Basic 05-119590BP	2003 IRC	2 story SFR w/attached garage	Plan:3023A	2005
New	1962 sq ft SFR with attached Garage				2005
New	Approved Basic 04-117064BP	2 story SFR w/attached garage	2003 IRC	Plan:Appalachian I	2005
New	Approved Basic 04-116494BP	2 story SFR w/attached garage	2003 IRC	Plan:Shasta Gable	2005
New	Approved Basic 04-116699BP	2 story SFR w/attached garage	2003 IRC	Plan: Madison Hip	2005
New	Approved Basic 04-116505BP	2 story SFR w/attached garage	2003 IRC	Plan:Appleton Gable	2005
New	Approved Basic 04-116700BP	2 story SFR w/attached garage	2003 IRC	Plan:Palisade Gable	2005
New	Approved Basic 04-116494BP	2 story SFR w/attached garage	2003 IRC	Plan:Shasta Gable	2005
New	Approved Basic 04-116700BP	2 story SFR w/attached garage	2003 IRC	Plan:Palisade Gable	2005
New	Approved Basic 04-116499BP	2 story SFR w/attached garage	2003 IRC	Plan:Tyndall Gable (	2005
New	Approved Basic 04-120920BP	2 story SFR w/attached	2003 IRC	Plan: Adams Gable(I)	2005
New	Approved Basic 04-118019BP	2 story SFR w/attached garage	2003 IRC	Plan:Teton Hip (I)	2005
New	Approved Basic 04-118013BP	2 story SFR w/attached garage	2003 IRC	Plan:Hazelwood Ga	2005
New	Approved Basic 04-118019BP	2 story SFR w/attached garage	2003 IRC	Plan:Teton Hip (I)	2005
New	Approved Basic 04-117066BP	2 story SFR w/attached garage	2003 IRC	Plan:Trinity Gab	2005
New	Approved Basic 04-118009BP	2 story SFR w/attached garage	2003 IRC	Plan:Granite Hip	2005
New	Approved Basic 04-117065BP	2 Story SFR w/attached garage	2003 IRC	Plan:Jasper G	2005
New	Approved Basic 04-116501BP	2 story SFR w/attached garage	2003 IRC	Plan:Glacier Gable	2005
New	Approved Basic 04-118009BP	2 story SFR w/attached garage	2003 IRC	Plan:Granite Hip	2005
New	Approved Basic 04-116489BP	2 story SFR w/attached garage	2003 IRC	Plan:Whitney Hip (I	2005
New	Approved Basic 04-116494BP	2 story SFR w/attached garage	2003 IRC	Plan:Shasta Gable	2005
New	Approved Basic 04-118013BP	2 story SFR w/attached garage	2003 IRC	Plan:Hazelwood Ga	2005
New	Approved Basic 04-116505BP	2 story SFR w/attached garage	2003 IRC	Plan:Appleton Gable	2005
New	Approved Basic 04-118013BP	2 story SFR w/attached garage	2003 IRC	Plan:Hazelwood Ga	2005
New	Approved Basic 04-118009BP	2 story SFR w/attached garage	2003 IRC	Plan:Granite Hip	2005

Accessory Dwelling Units

Index # - File Name: 1.0022 - Single Family Dwellings Data\_Snohomish County.pdf

New	Approved	Basic 04-116508BP	2 story SFR w/attached garage	2003 IRC	Plan:Langley Hip (I)	2005
New	Approved	Basic 04-118337BP	2 story sfr w/attached garage	2003 IRC	Plan:Olympic Gabl	2005
New	Approved	Basic 04-120922BP	SFR w/finished basement & attached garage	2003 IRC	Pla	2005
New	Approved	Basic 04-118337BP	2 story sfr w/attached garage	2003 IRC	Plan:Olympic Gabl	2005
New	Approved	Basic 04-116505BP	2 story SFR w/attached garage	2003 IRC	Plan:Appleton Gable	2005
New	Approved	Basic 04-117062BP	2 story SFR w/attached garage	2003 IRC	Plan:Whitney Gable	2005
New	Approved	Basic 04-118337BP	2 story sfr w/attached garage	2003 IRC	Plan:Olympic Gabl	2005
New	Approved	Basic 05-100768BP		2003 IRC	Plan:Columbia Gable(I)	2005
New	Approved	Basic 04-118009BP	2 story SFR w/attached garage	2003 IRC	Plan:Granite Hip	2005
New	Approved	Basic 04-116508BP	2 story SFR w/attached garage	2003 IRC	Plan:Langley Hip (I)	2005
New	Approved	Basic 04-116499BP	2 story SFR w/attached garage	2003 IRC	Plan:Tyndall Gable (	2005
New	Approved	Basic 04-116494BP	2 story SFR w/attached garage	2003 IRC	Plan:Shasta Gable	2005
New	Approved	Basic 04-117062BP	2 story SFR w/attached garage	2003 IRC	Plan:Whitney Gable	2005
New	Approved	Basic 05-100768BP		2003 IRC	Plan:Columbia Gable(I)	2005
New	Approved	Basic 04-116699BP	2 story SFR w/attached garage	2003 IRC	Plan: Madison Hip	2005
New	Approved	Basic 04-116508BP	2 story SFR w/attached garage	2003 IRC	Plan:Langley Hip (I)	2005
New	Approved	Basic 04-118013BP	2 story SFR w/attached garage	2003 IRC	Plan:Hazelwood Ga	2005
New	Approved	Basic 04-117063BP	Tri w/finished basement & attached garage	2003 IRC	Plan: F	2005
New	Approved	Basic 04-118019BP	2 story SFR w/attached garage	2003 IRC	Plan:Teton Hip (I)	2005
New	Approved	Basic 04-120922BP	SFR w/finished basement & attached garage	2003 IRC	Pla	2005
New	Approved	Basic 04-117066BP	2 story SFR w/attached garage	2003 IRC	Plan:Trinity Gab	2005
New	Approved	Basic 04-116508BP	2 story SFR w/attached garage	2003 IRC	Plan:Langley Hip (I)	2005
New	Approved	Basic 04-118019BP	2 story SFR w/attached garage	2003 IRC	Plan:Teton Hip (I)	2005
New	Approved	Basic 04-116494BP	2 story SFR w/attached garage	2003 IRC	Plan:Shasta Gable	2005
New	Approved	Basic 04-118013BP	2 story SFR w/attached garage	2003 IRC	Plan:Hazelwood Ga	2005
New	Approved	Basic 04-117066BP	2 story SFR w/attached garage	2003 IRC	Plan:Trinity Gab	2005
New	Approved	Basic 04-116501BP	2 story SFR w/attached garage	2003 IRC	Plan:Glacier Gable	2005
New	Approved	Basic 04-117062BP	2 story SFR w/attached garage	2003 IRC	Plan:Whitney Gable	2005
New	Approved	Basic 04-116505BP	2 story SFR w/attached garage	2003 IRC	Plan:Appleton Gable	2005
New	Approved	Basic 04-120920BP	2 story SFR w/attached	2003 IRC	Plan: Adams Gable(I)	2005
New	Approved	Basic 04-116699BP	2 story SFR w/attached garage	2003 IRC	Plan: Madison Hip	2005
New	Approved	Basic 04-116508BP	2 story SFR w/attached garage	2003 IRC	Plan:Langley Hip (I)	2005
New	Approved	Basic 04-116494BP	2 story SFR w/attached garage	2003 IRC	Plan:Shasta Gable	2005
New	Approved	Basic 04-118013BP	2 story SFR w/attached garage	2003 IRC	Plan:Hazelwood Ga	2005
New	Approved	Basic 04-116501BP	2 story SFR w/attached garage	2003 IRC	Plan:Glacier Gable	2005
New	Approved	Basic 04-120922BP	SFR w/finished basement & attached garage	2003 IRC	Pla	2005
New	Approved	Basic 04-118334BP	2 story SFR w/attached garage	2003 IRC	Plan:Waterton Gabl	2005
New	Approved	Basic 04-118019BP	2 story SFR w/attached garage	2003 IRC	Plan:Teton Hip (I)	2005
New	Approved	Basic 04-114589BP	2 story sfr w/attached garage	2003 IRC	Plan:Jefferson Gabl	2005
New	Approved	Basic 04-117066BP	2 story SFR w/attached garage	2003 IRC	Plan:Trinity Gab	2005
New	Approved	Basic 04-118334BP	2 story SFR w/attached garage	2003 IRC	Plan:Waterton Gabl	2005
New	Approved	Basic 04-118013BP	2 story SFR w/attached garage	2003 IRC	Plan:Hazelwood Ga	2005
New	Approved	Basic 04-116501BP	2 story SFR w/attached garage	2003 IRC	Plan:Glacier Gable	2005
New	Approved	Basic 04-118009BP	2 story SFR w/attached garage	2003 IRC	Plan:Granite Hip	2005
New	Approved	Basic 04-120921BP	2 story SFR w/attached garage	2003 IRC	Plan:Siskiyou	2005
New	Approved	Basic 04-116494BP	2 story SFR w/attached garage	2003 IRC	Plan:Shasta Gable	2005
New	Approved	Basic 04-117065BP	2 Story SFR w/attached garage	2003 IRC	Plan:Jasper G	2005

Accessory Dwelling Units

Index # - File Name: 1.0022 - Single Family Dwellings Data\_Snohomish County.pdf

New	Approved	Basic 04-116494BP	2 story SFR w/attached garage	2003 IRC	Plan:Shasta Gable	2005
New	Approved	Basic 04-117065BP	2 Story SFR w/attached garage	2003 IRC	Plan:Jasper G	2005
New	Approved	Basic 04-117066BP	2 story SFR w/attached garage	2003 IRC	Plan:Trinity Gab	2005
New	Approved	Basic 04-118019BP	2 story SFR w/attached garage	2003 IRC	Plan:Teton Hip (I)	2005
New	Approved	Basic 04-117065BP	2 Story SFR w/attached garage	2003 IRC	Plan:Jasper G	2005
New	Approved	Basic 04-120922BP	SFR w/finished basement & attached garage	2003 IRC	Pla	2005
New	Approved	Basic 04-116505BP	2 story SFR w/attached garage	2003 IRC	Plan:Appleton Gable	2005
New	Approved	Basic 04-116494BP	2 story SFR w/attached garage	2003 IRC	Plan:Shasta Gable	2005
New	Approved	Basic 04-116501BP	2 story SFR w/attached garage	2003 IRC	Plan:Glacier Gable	2005
New	Approved	Basic 04-116494BP	2 story SFR w/attached garage	2003 IRC	Plan:Shasta Gable	2005
New	Approved	Basic 04-116508BP	2 story SFR w/attached garage	2003 IRC	Plan:Langley Hip (I)	2005
New	Approved	Basic 04-118019BP	2 story SFR w/attached garage	2003 IRC	Plan:Teton Hip (I)	2005
New	Approved	Basic 04-117066BP	2 story SFR w/attached garage	2003 IRC	Plan:Trinity Gab	2005
New	Approved	Basic 04-117065BP	2 Story SFR w/attached garage	2003 IRC	Plan:Jasper G	2005
New	Approved	Basic 04-116505BP	2 story SFR w/attached garage	2003 IRC	Plan:Appleton Gable	2005
New	Approved	Basic 04-117065BP	2 Story SFR w/attached garage	2003 IRC	Plan:Jasper G	2005
New	Approved	Basic 04-117064BP	2 story SFR w/attached garage	2003 IRC	Plan:Appalachian F	2005
New	Approved	Basic 04-116501BP	2 story SFR w/attached garage	2003 IRC	Plan:Glacier Gable	2005
New	Approved	Basic 04-118013BP	2 story SFR w/attached garage	2003 IRC	Plan:Hazelwood Ga	2005
New	Approved	Basic 04-118009BP	2 story SFR w/attached garage	2003 IRC	Plan:Granite Hip	2005
New	Approved	Basic 04-118334BP	2 story SFR w/attached garage	2003 IRC	Plan:Waterton Gabl	2005
New	Approved	Basic 04-116505BP	2 story SFR w/attached garage	2003 IRC	Plan:Appleton Gable	2005
New	Approved	Basic 04-116494BP	2 story SFR w/attached garage	2003 IRC	Plan:Shasta Gable	2005
New	Approved	Basic 04-116499BP	2 story SFR w/attached garage	2003 IRC	Plan:Tyndall Gable (	2005
New	Approved	Basic 04-116508BP	2 story SFR w/attached garage	2003 IRC	Plan:Langley Hip (I)	2005
New	Approved	Basic 04-117062BP	2 story SFR w/attached garage	2003 IRC	Plan:Whitney Gable	2005
New	Approved	Basic 04-118013BP	2 story SFR w/attached garage	2003 IRC	Plan:Hazelwood Ga	2005
New	Approved	Basic 04-116501BP	2 story SFR w/attached garage	2003 IRC	Plan:Glacier Gable	2005
New	Approved	Basic 04-116494BP	2 story SFR w/attached garage	2003 IRC	Plan:Shasta Gable	2005
New	Approved	Basic 04-116499BP	2 story SFR w/attached garage	2003 IRC	Plan:Tyndall Gable (	2005
New	Approved	Basic 04-116505BP	2 sstory SFR w/attached garage	2003 IRC	Plan:Appleton Gabl	2005
New	Approved	Basic 04-117066BP	2 story SFR w/attached garage	2003 IRC	Plan:Trinity Gab	2005
New	Approved	Basic 04-116508BP	2 story SFR w/attached garage	2003 IRC	Plan:Langley Hip (I)	2005
New	Approved	Basic 04-118334BP	2 story SFR w/attached garage	2003 IRC	Plan:Waterton Gabl	2005
New	Approved	Basic 04-118013BP	2 story SFR w/attached garage	2003 IRC	Plan:Hazelwood Ga	2005
New	Approved	Basic 04-116501BP	2 story SFR w/attached garage	2003 IRC	Plan:Glacier Gable	2005
New	Approved	Basic 04-120920BP	2 story SFR w/attached	2003 IRC	Plan: Adams Gable(I)	2005
New	Approved	Basic 04-116489BP	2 story SFR w/attached garage	2003 IRC	Plan:Whitney Hip (I)	2005
New	Approved	Basic 04-116501BP	2 story SFR w/attached garage	2003 IRC	Plan:Glacier Gable	2005
New	Approved	Basic 04-116508BP	2 story SFR w/attached garage	2003 IRC	Plan:Langley Hip (I)	2005
New	Approved	Basic 04-117066BP	2 story SFR w/attached garage	2003 IRC	Plan:Trinity Gab	2005
New	Approved	Basic 04-120922BP	SFR w/finished basement & attached garage	2003 IRC	Pla	2005
New	Approved	Basic 04-118013BP	2 story SFR w/attached garage	2003 IRC	Plan:Hazelwood Ga	2005
New	Approved	Basic 04-120920BP	2 story SFR w/attached	2003 IRC	Plan: Adams Gable(I)	2005
New	Approved	Basic 04-116494BP	2 story SFR w/attached garage	2003 IRC	Plan:Shasta Gable	2005
New	Approved	Basic 04-118019BP	2 story SFR w/attached garage	2003 IRC	Plan:Teton Hip (I)	2005
New	Approved	Basic 04-120920BP	2 story SFR w/attached	2003 IRC	Plan: Adams Gable(I)	2005

Accessory Dwelling Units

Index # - File Name: 1.0022 - Single Family Dwellings Data\_Snohomish County.pdf

New	Approved Basic 04-116494BP	2 story SFR w/attached garage	2003 IRC	Plan:Shasta Gable	2005
New	Approved Basic 04-116501BP	2 story SFR w/attached garage	2003 IRC	Plan:Glacier Gable	2005
New	Approved Basic 04-116508BP	2 story SFR w/attached garage	2003 IRC	Plan:Langley Hip (I)	2005
New	Approved Basic 04-116501BP	2 story SFR w/attached garage	2003 IRC	Plan:Glacier Gable	2005
New	Approved Basic 04-116494BP	2 story SFR w/attached garage	2003 IRC	Plan:Shasta Gable	2005
New	Approved Basic 04-118337BP	2 story sfr w/attached garage	2003 IRC	Plan:Olympic Gabl	2005
New	Approved Basic 04-116489BP	2 story SFR w/attached garage	2003 IRC	Plan:Whitney Hip (I)	2005
New	Approved Basic 04-120920BP	2 story SFR w/attached	2003 IRC	Plan: Adams Gable(I)	2005
New	Approved Basic 04-116494BP	2 story SFR w/attached garage	2003 IRC	Plan:Shasta Gable	2005
New	Approved Basic 04-118013BP	2 story SFR w/attached garage	2003 IRC	Plan:Hazelwood Ga	2005
New	Approved Basic 04-116508BP	2 story SFR w/attached garage	2003 IRC	Plan:Langley Hip (I)	2005
New	Approved Basic 04-117062BP	2 story SFR w/attached garage	2003 IRC	Plan:Whitney Gable	2005
New	Approved Basic 05-121678BP	2003 IRC 2 story SFR w/attached garage		Plan:241	2005
New	Approved Basic 05-118924BP	2003 IRC 2 story SFR w/attached garage		Plan:2621C	2005
New	Approved Basic 04-117263BP	2 story SFR w/attached garage	2003 IRC	Plan:3131B	2005
New	Approved Basic 04-119214BP	2 story SFR w/attached garage	2003 IRC	Plan:2831 A & C	2005
New	Approved Basic 04-116513BP			Plan: 2421 A & B Two-story SFR with atta	2005
New	Approved Basic 05-120007BP	2003 IRC 2 story SFR w/attached garage		Plan:3531	2005
New	Approved Basic 05-121242BP	2003 IRC 2 story SFR w/attached garage		Plan:3641C	2005
New	Approved Basic 04-116493BP			Plan: 2421 C Two-story SFR with attached	2005
New	Approved basic 05-122161 BP	2003 IRC Plan# 3131C		2 - story sfr w/attached garag	2005
New	2-Story SFR w/attached garage.				2005
New	Approved Basic 04-116513BP			Plan: 2421 A & B Two-story SFR with atta	2005
New	Approved Basic 04-120107BP	2 story SFR w/attached garage	2003 IRC	Plan:3121C	2005
New	Two story SFR with attached garage				2005
New	2 story unfinished basmt w/attached garage				2005
New	2-Story SFR w/attached garage.				2005
New	Two story SFR with attached Garage				2005
New	Two-story SFR				2005
New	Two-story SFR with unfinished basement and attached garage -	2003 IRC			2005
New	One-story SFR with 285sf unfinished basement and attached garage -	2003 IRC			2005
New	Approved Basic 05-118736BP	2003 IRC 2 story SFR w/attached garage		Plan:2999w/	2005
New	Approved Basic 05-118736BP	2003 IRC 2 story SFR w/attached garage		Plan:2999w/	2005
New	Approved Basic 05-118728BP	2003 IRC 2 story SFR w/attached garage		Plan:3;	2005
New	Approved Basic 05-118728BP	2003 IRC 2 story SFR w/attached garage		Plan:3;	2005
New	Approved Basic 05-118736BP	2003 IRC 2 story SFR w/attached garage		Plan:2999w	2005
New	Approved Basic 05-118740BP	2003 IRC 2 story SFR w/attached garage		Plan:2786	2005
New	Approved Basic 05-118736BP	2003 IRC 2 story SFR w/attached garage		Plan:2999w/	2005
New	Approved Basic 05-118728BP	2003 IRC 2 story SFR w/attached garage		Plan:3;	2005
New	Approved Basic 05-118736BP	2003 IRC 2 story SFR w/attached garage		Plan:2999w/	2005
New	Approved Basic 05-118736BP	2003 IRC 2 story SFR w/attached garage		Plan:2999w/	2005
New	Approved Basic 05-118728BP	2003 IRC 2 story SFR w/attached garage		Plan:3;	2005
New	Approved Basic 05-118736BP	2003 IRC 2 story SFR w/attached garage		Plan:2999w/	2005
New	Approved Basic 05-118728BP	2003 IRC 2 story SFR w/attached garage		Plan:3;	2005
New	INSPECTIONS WERE BEGUN ON 05-121668. gb 10/13/05	Approved Basic 05-118734BP			2005
New	Approved Basic 05-118740BP	2003 IRC 2 story SFR w/attached garage		Plan:2786	2005
New	Approved Basic 05-118736BP	2003 IRC 2 story SFR w/attached garage		Plan:2999w/	2005

Accessory Dwelling Units

Index # - File Name: 1.0022 - Single Family Dwellings Data\_Snohomish County.pdf

New	Approved Basic 05-118728BP	2003 IRC	2 story SFR w/attached garage	Plan:31	2005
New	Approved Basic 05-118740BP	2003 IRC	2 story SFR w/attached garage	Plan:2786	2005
New	Approved Basic 05-118734BP	2003 IRC	2 story SFR w/attached garage	Plan:2999	2005
New	Approved Basic 05-118728BP	2003 IRC	2 story SFR w/attached garage	Plan:31	2005
New	Approved Basic 05-118740BP	2003 IRC	2 story SFR w/attached garage	Plan:2786	2005
New	Approved Basic 05-118732BP	2003 IRC	2 story SFR w/attached garage	Plan:3007	2005
New	Approved Basic 05-118736BP	2003 IRC	2 story SFR w/attached garage	Plan:2999w/	2005
New	Approved Basic 05-118741BP	2003 IRC	2 story SFR w/attached garage	Plan:2786	2005
New	Two story SFR with attached garage				2005
New	Two story SFR with attached Garage				2005
New	Two-story sfr with garage				2005
New	Approved Basic 05-118736BP	2003 IRC	2 story SFR w/attached garage	Plan:2999w/	2005
New	Two-story sfr with garage				2005
New	2 story w/ attached 3 car garage				2005
New	Approved basic 05-123186 BP	2003 IRC	Plan# 2760	2-story sfr w/attached garage	2005
New	Approved basic 05-124812 BP	2003 IRC	Plan# 2802 conv	2-story sfr w/attached	2005
New	Approved basic 05-123186 BP	2003 IRC	Plan#2760	2-story sfr w/attached garage	2005
New	Approved Basic 05-122932 BP	2003 IRC	Plan# 9514	2-story sfr w/attached gara	2005
New	Two Story SFR with Semi Finished Basement and Attached Garage				2005
New	Duplex w/garage & covered porch	2003 IRC			2005
New	Approved Basic 04-117192BP,	2003 IRC, Plan 2225 -	SFR Rambler with Attached Garage		2005
New	2-Story SFR w/attached garage.				2005
New	2-Story SFR w/attached garage.				2005
New	Approved Basic 04-115896BP		Builders Plan #2271AC	2 Story w/ 3 Car	2005
New	Approved Basic 04-119744 BP	2 story SFR w/attached garage	2003 IRC	Plan:2214	2005
New	2-Story SFR w/attached garage.				2005
New	Approved Basic #04-114690 BP		Plan: 04002-1	2-story w/garage (2003IRC/IBC)	2005
New	Approved Basic 05-100998BP	2003 IRC	2 story SFR w/attached garage	Plan:2610A	2005
New	Approved Basic 05-100998BP	2003 IRC	2 story SFR w/attached garage	Plan:2610A	2005
New	Approved Basic 05-100995BP	2003 IRC	2 story SFR w/attached garage	Plan:2707	2005
New	Approved Basic 05-100995BP	2003 IRC	2 story SFR w/attached garage	Plan:2	2005
New	Approved Basic 05-100995BP	2003 IRC	2 story SFR w/attached garage	Plan:2707	2005
New	Approved Basic 100993BP				2005
New	Approved basic 05-119739 BP	2003 IRC	Plan# 1804 A	Rambler w/attached gara	2005
New	Approved basic 05-117305 BP	2003 IRC	Plan# 0419-A	2-story sfr w/attached gar	2005
New	Approved Basic 04 -120672 BP			2 story SFRw/attached garage	2005
New	Approved basic 05-117305 BP	2003 IRC	Plan# 0419-A	2-story sfr w/attached gar	2005
New	Approved Basic 04 -120672 BP			2 story SFRw/attached garage	2005
New	Approved basic 05-117305 BP	2003 IRC	Plan# 0419-A	2-story sfr w/attached gar	2005
New	Approved basic 05-117305 BP	2003 IRC	Plan# 0419-A	2-story sfr w/attached gar	2005
New	Approved Basic 05-121184BP	2003 IRC	Two-story SFR with attached garage	Plan: 0509	2005
New	Approved Basic 04-120734BP	SFR w/ Finished Basement & Attached Garage	2003 IRC		2005
New	Approved Basic 05-117307 BP	2003 IRC	Plan# 2195A2F 10	Split entry w/attache	2005
New	Approved Basic 04-120734BP	SFR w/ Finished Basement & Attached Garage	2003 IRC		2005
New	Approved Basic 05-117307 BP	2003 IRC	Plan# 2195A2F 10	Split entry w/attache	2005
New	Two-story SFR with attached garage -	2003 IRC	Plan: Bennington		2005
New	Approved Basic 05 120851 BP			Builder s Plan 2452/3 C	2005

Accessory Dwelling Units

Index # - File Name: 1.0022 - Single Family Dwellings Data\_Snohomish County.pdf

New	Approved Basic 05-120000BP	2003 IRC	Plan: Rochester	2 story SFR w/attached garage	2005
New	Approved Basic #05-118418 BP	2003 IRC	Plan #2452	Two story SFR w/ Attached Garage	2005
New	Approved Basic 05-120000BP	2003 IRC	Plan: Rochester	2 story SFR w/attached garage	2005
New	Two story SFR with attached Garage				2005
New	Two-story sfr with garage				2005
New	Approved Basic 05 120851 BP			Builder s Plan 2452/3 Ca	2005
New	Approved Basic 05-120000BP	2003 IRC	Plan: Rochester	2 story SFR w/attached garage	2005
New	Two story SFR with attached Garage				2005
New	2 - story sfr w/attached garage				2005
New	Approved basic 05-118890 BP	2003 IRC	Plan #2520	2 - story SFR w/attached garage	2005
New	Approved basic 05-118890 BP	2003 IRC	Plan #2520	2 - story SFR w/attached garage	2005
New	Two-story sfr with garage				2005
New	Approved basic 05-118624 BP	2003 IRC	Plan# Hawthorne	2 - story SFR w/attached garage	2005
New	Approved basic 05-118880 BP	2003IRC	Plan #2490	2 - story SFR w/attached garage	2005
New	Approved basic 05-118880 BP	2003IRC	Plan #2490	2 - story SFR w/attached garage	2005
New	Approved Basic 04-116584BP	2 story SFR w/attached garage	2003 IRC	Plan:2338A3FT-	2005
New	Approved basic 05-118890 BP	2003 IRC	Plan #2520	2 - story SFR w/attached garage	2005
New	2 story SFR w/attached garage	2003 IRC	Plan:2698		2005
New	Approved Basic 04-116584BP	2 story SFR w/attached garage	2003 IRC	Plan:2338A3FT-	2005
New	Approved basic 05-122156 BP	2003 IRC	Plan# 2780	2 - story sfr w/attached garage	2005
New	Approved 05-122154 BP	2003 IRC	Plan# 2645	2 - story sfr w/attached garage	2005
New	2 - story SFR w/attached garage				2005
New	Approved Basic 05-118624 BP	2003 IRC	Plan# Hawthorne	2 - story SFR w/attached garage	2005
New	Two-story sfr with garage				2005
New	Two story SFR with attached Garage				2005
New	2-story SFR w/garage				2005
New	One story sfr with garage (prior sfr burned down).				2005
New	Daylight basement SFR w/attached garage.				2005
New	2 story SFR w/attached garage	2003 IRC	Plan:Senica A		2005
New	2 story SFR w/attached garage	2003 IRC	Plan:Salish A		2005
New	2 - story sfr w/attached garage				2005
New	2-story sfr w/attached garage				2005
New	2-story sfr w/attached garage				2005
New	2-story sfr w/attached garage				2005
New	2-story sfr w/attached garage				2005
New	2386 sqft Rambler w/ attchd 3 car garage				2005
New	Two Story SFR with Attached Garage	2003 IRC		*****PLA	2005
New	2498 Sq Ft Rambler with Attached Garage	2003 IRC		*****	2005
New	Approved basic 05-123184 BP	2003 IRC	Plan 3025	2-story sfr w/attached garage	2005
New	2-story sfr w/attached garage				2005
New	2-story sfr w/attached garage				2005
New	2-story sfr w/attached garage				2005
New	2-story sfr w/attached garage				2005
New	2-story sfr w/attached garage				2005
New	2 - story sfr w/attached garage				2005
New	2-story sfr w/attached garage				2005
New	Duplex with Attached Garages				2005
		2003 IRC			



Accessory Dwelling Units

Index # - File Name: 1.0022 - Single Family Dwellings Data\_Snohomish County.pdf

New	Approved	Basic 04-114589BP	2 story sfr w/attached garage	2003 IRC	Plan:Jefferson Gable	2005
New	Approved	Basic 04-118009BP	2 story SFR w/attached garage	2003 IRC	Plan:Granite Hip	2005
New	Approved	Basic 04-118019BP	2 story SFR w/attached garage	2003 IRC	Plan:Teton Hip (I)	2005
New	Approved	Basic 04-120920BP	2 story SFR w/attached	2003 IRC	Plan: Adams Gable(I)	2005
New	Approved	Basic 04-118334BP	2 story SFR w/attached garage	2003 IRC	Plan:Waterton Gable	2005
New	Approved	Basic 04-116505BP	2 story SFR w/attached garage	2003 IRC	Plan:Appleton Gable	2005
New	Approved	Basic 04-116494BP	2 story SFR w/attached garage	2003 IRC	Plan:Shasta Gable	2005
New	Approved	Basic 04-117066BP	2 story SFR w/attached garage	2003 IRC	Plan:Trinity Gab	2005
New	Approved	Basic 04-118334BP	INSPECTIONS STARTED ON 05-117657RK.	2 story SFR w/attach		2005
New	Approved	Basic 04-120920BP	2 story SFR w/attached	2003 IRC	Plan: Adams Gable(I)	2005
New	Approved	Basic 04-118337BP	2 story sfr w/attached garage	2003 IRC	Plan:Olympic Gable	2005
New	Approved	Basic 04-116489BP	2 story SFR w/attached garage	2003 IRC	Plan:Whitney Hip (I)	2005
New	Approved	Basic 04-118009BP	2 story SFR w/attached garage	2003 IRC	Plan:Granite Hip	2005
New	Approved	Basic 04-117062BP	2 story SFR w/attached garage	2003 IRC	Plan:Whitney Gable	2005
New	Approved	Basic 04-118337BP	2 story sfr w/attached garage	2003 IRC	Plan:Olympic Gable	2005
New	Approved	Basic 04-118009BP	2 story SFR w/attached garage	2003 IRC	Plan:Granite Hip	2005
New	Approved	Basic 04-120920BP	2 story SFR w/attached	2003 IRC	Plan: Adams Gable(I)	2005
New	Approved	Basic 04-118334BP	2 story SFR w/attached garage	2003 IRC	Plan:Waterton Gable	2005
New	Approved	Basic 04-118013BP	2 story SFR w/attached garage	2003 IRC	Plan:Hazelwood Ga	2005
New	Approved	Basic 04-116505BP	2 story SFR w/attached garage	2003 IRC	Plan:Appleton Gable	2005
New	Approved	Basic 04-116489BP	2 story SFR w/attached garage	2003 IRC	Plan:Whitney Hip (I)	2005
New	Approved	Basic 05-118204BP	2003 IRC	2 story SFR w/attached garage	Plan:3	2005
New	Approved	Basic 05-116903BP	2003 IRC		Plan:3027A	2005
New	Approved	Basic 05-118281BP	2003 IRC	2 story SFR w/attached garage	Plan:289	2005
New	Approved	Basic 05-118204BP	2003 IRC	2 story SFR w/attached garage	Plan:3	2005
New	Approved	Basic 05-116904BP	2003 IRC		Plan:2892A	2005
New	Approved	Basic 05-120912BP	2003 IRC	2 story SFR w/attached garage	Plan:2706A	2005
New	Approved	Basic 05-118199BP	2003 IRC	2 story SFR w/attached garage	Plan:2892/	2005
New	Approved	Basic 05-118204BP	2003 IRC	2 story SFR w/attached garage	Plan:3	2005
New	Approved	Basic 05-121224BP	2003 IRC	2 story SFR w/attached garage	Plan:291.	2005
New	Approved	Basic 05-118284BP	2003 IRC	2 story SFR w/attached garage	Plan:3027B	2005
New	Approved	Basic 05-116898	2005 IRC		Plan:3114A	2005
New	Approved	Basic 05-120468BP	2003 IRC	2 story SFR w/attached garage	Plan:3027B	2005
New	Approved	Basic 05-125684BP	2003 IRC	2 story SFR w/attached garage	Plan:3027A	2005
New			2 story SFR w/attached garage	2003 IRC	Plan:2753	2005
New			foundation for SFR being moved onto site & work as per inspection report #05-119671IR			2005
New	Approved	Basic 05-118209BP	2003 IRC	2 story SFR w/attached garage	Plan:302	2005
New	Approved	Basic 05- 124155BP	2003 IRC	2 story SFR w/attached garage	Plan:3114B	2005
New	Approved	Basic 05-116903BP	2003 IRC		Plan:3027A	2005
New	Approved	Basic 05-118204BP	2003 IRC	2 story SFR w/attached garage	Plan:3	2005
New	Approved	Basic 05-120912BP	2003 IRC	2 story SFR w/attached garage	Plan:2706A	2005
New	Approved	Basic 05-116898	2005 IRC		Plan:3114A	2005
New	Approved	Basic 05-119894BP	2003 IRC	2 story SFR w/attached garage	Plan:3162	2005
New	Approved	Basic 05-118883BP	2003 IRC	2 story SFR w/attached garage	Plan:324	2005
New	Approved	Basic 05-116903BP	2003 IRC		Plan:3027A	2005
New	Approved	Basic 05-116898	2005 IRC		Plan:3114A	2005
New	Approved	Basic 05-116903BP	2003 IRC		Plan:3027A	2005

Accessory Dwelling Units

Index # - File Name: 1.0022 - Single Family Dwellings Data\_Snohomish County.pdf

New	Approved Basic 05-121224BP	2003 IRC	2 story SFR w/attached garage	Plan:2914	2005
New	Approved Basic 05-120912BP	2003 IRC	2 story SFR w/attached garage	Plan:2706A	2005
New	Approved Basic 05-11204BP	2003 IRC	2 story SFR w/attached garage	Plan:	2005
New	Approved Basic 05-118202BP	2003 IRC	2 story SFR w/attatched garage	Plan:289	2005
New	Approved Basic 05-118209BP	2003 IRC	2 story SFR w/attached garage	Plan:302	2005
New	2 story SFR w/attached garage	2003 IRC	Plan:3027B		2005
New	Approved Basic 05-118204BP	2003 IRC	2 story SFR w/attached garage	Plan:3	2005
New	Approved Basic 05-118278BP	2003 IRC	2 story SFR w/attached garage	Plan:32	2005
New	Approved Basic 05-118281BP	2003 IRC	2 story SFR w/attached garage	Plan:2892	2005
New	Approved Basic 05-116898	2005 IRC	Plan:3114A		2005
New	Approved Basic 05-116903BP	2003 IRC	Plan:3027A		2005
New	Approved Basic 05-127542BP	2003 IRC	2 story SFR w/attached garage	Plan:2505B	2005
New	Approved Basic 05-118281BP	2003 IRC	2 story SFR w/attached garage	Plan:2892	2005
New	Approved Basic 05-120468BP	2003 IRC	2 story SFR w/attached garage	Plan:3027B	2005
New	Approved Basic 05-119894BP	2003 IRC	2 story SFR w/attached garage	Plan:3162	2005
New	Approved Basic 05-127542BP	2003 IRC	2 story SFR w/attached garage	Plan:2505B	2005
New	Approved Basic 05-118204BP	2003 IRC	2 story SFR w/attached garage	Plan:3	2005
New	Approved Basic 05-118284BP	2003 IRC	2 story SFR w/attached garage	Plan:3027B	2005
New	Approved Basic 05-116898	2005 IRC	Plan:3114A		2005
New	2 story SFR w/attached garage	2003 IRC	PlanM2415A3F-4		2005
New	Approved Basic 05-118204BP	2003 IRC	2 story SFR w/attached garage	Plan:3	2005
New	Approved Basic 05-118209BP	2003 IRC	2 story SFR w/attached garage	Plan:302	2005
New	Approved Basic 05-116904BP	2003 IRC	Plan:2892A		2005
New	Approved Basic 05-118284BP	2003 IRC	2 story SFR w/attached garage	Plan:3027B	2005
New	Approved Basic 05-118278BP	2003 IRC	2 story SFR w/attached garage	Plan:324	2005
New	Approved Basic 05-116903BP	2003 IRC	Plan:3027A		2005
New	Approved Basic 05-118284BP	2003 IRC	2 story SFR w/attached garage	Plan:3027B	2005
New	Approved Basic 05-118204BP	2003 IRC	2 story SFR w/attached garage	Plan:3	2005
New	Approved Basic 05-116898	2005 IRC	Plan:3114A		2005
New	Approved Basic 05-119991BP	2003 IRC	2 story SFR w/attached garage	Plan:3027C	2005
New	Approved Basic 05-127545BP	2003 IRC	2 story SFR w/attached garage	Plan:2892B	2005
New	Approved Basic 05-120468BP	2003 IRC	2 story SFR w/attached garage	Plan:3027B	2005
New	Approved Basic 05-118284BP	2003 IRC	2 story SFR w/attached garage	Plan:3027B	2005
New	Approved Basic 05-119894BP	2003 IRC	2 story SFR w/attached garage	Plan:3162	2005
New	Approved Basic 05-118204BP	2003 IRC	2 story SFR w/attached garage	Plan:3	2005
New	Approved Basic 05-118854BP	2003 IRC	Plan:2914A		2005
New	Approved Basic 05-116903BP	2003 IRC	Plan:3027A		2005
New	Approved Basic 05-119894BP	2003 IRC	2 story SFR w/attached garage	Plan:3162	2005
New	Approved Basic 05-118284BP	2003 IRC	2 story SFR w/attached garage	Plan:3027B	2005
New	Approved Basic 05-118209BP	2003 IRC	2 story SFR w/attached garage	Plan:302	2005
New	Approved Basic 05-118883BP	2003 IRC	2 story SFR w/attached garage	Plan:324C	2005
New	Approved Basic 05-118204BP	2003 IRC	2 story SFR w/attached garage	Plan:3	2005
New	Approved Basic 05-116903BP	2003 IRC	Plan:3027A		2005
New	Approved Basic 05-118854BP	2003 IRC	Plan:2914A		2005
New	2 story single family residence with attached 2 car garage				2005
New	Approved Basic #04-118889 BP		2-story w/garage	2003 IRC	2005
New	Approved Basic 04-119755BP	2 story SFR w/attached garage	2003 IRC	Plan:1325	2005

Accessory Dwelling Units

Index # - File Name: 1.0022 - Single Family Dwellings Data\_Snohomish County.pdf

New	Approved Basic #04-118889 BP			2-story w/garage	2003 IRC	2005
New	Approved Basic 05-121428 BP	2003 IRC	Plan# 1825	2-story sfr w/attached garage		2005
New	Approved Basic 05-121428 BP	2003 IRC	Plan# 1825	2-story sfr w/attached garage		2005
New	Approved Basic #04-118889 BP			2-story w/garage	2003 IRC	2005
New	Approved Basic #04-118889 BP			2-story w/garage	2003 IRC	2005
New	Approved Basic #04-118889 BP			2-story w/garage	2003 IRC	2005
New	Approved Basic 05-121428 BP	2003 IRC	Plan# 1825	2-story sfr w/attached garage		2005
New	Approved Basic #04-118889 BP			2-story w/garage	2003 IRC	2005
New	Approved basic 05-120842 BP	2003 IRC	Plan #: 1885	2-story sfr w/attached garage		2005
New	Approved Basic 05-121428 BP	2003 IRC	Plan# 1825	2-story sfr w/attached garage		2005
New	Approved Basic #04-118889 BP			2-story w/garage	2003 IRC	2005
New	Approved basic 05-120842 BP	2003 IRC	Plan #: 1885	2-story sfr w/attached garage		2005
New	Approved Basic #04-118889 BP			2-story w/garage	2003 IRC	2005
New	Approved 05-121428 BP	2003 IRC	Plan# 1825	2-story sfr w/attached garage		2005
New	Approved Basic 04-119755BP	2 story SFR w/attached garage		2003 IRC	Plan:1325	2005
New	Approved Basic #04-118889 BP			2-story w/garage	2003 IRC	2005
New	Approved Basic 04-119755BP	2 story SFR w/attached garage		2003 IRC	Plan:1325	2005
New	Approved Basic #04-118889 BP			2-story w/garage	2003 IRC	2005
New	Approved Basic #04-118889 BP			2-story w/garage	2003 IRC	2005
New	Approved Basic #04-118889 BP			2-story w/garage	2003 IRC	2005
New	Approved Basic 04-119755BP	2 story SFR w/attached garage		2003 IRC	Plan:1325 n	2005
New	Approved Basic #04-118889 BP			2-story w/garage	2003 IRC	2005
New	Approved Basic #04-118889 BP			2-story w/garage	2003 IRC	2005
New	Approved Basic #04-118889 BP			2-story w/garage	2003 IRC	2005
New	Approved Basic #04-118889 BP			2-story w/garage	2003 IRC	2005
New	Approved Basic #04-118889 BP			2-story w/garage	2003 IRC	2005
New	Approved Basic #04-118889 BP			2-story w/garage	2003 IRC	2005
New	Approved Basic #04-118889 BP			2-story w/garage	2003 IRC	2005
New	Approved Basic 05-121428 BP	2003 IRC	Plan# 1825	2-story sfr w/attached garage		2005
New	Approved Basic #04-118889 BP			2-story w/garage	2003 IRC	2005
New	Approved Basic #04-118889 BP			2-story w/garage	2003 IRC	2005
New	Approved Basic #04-118889 BP			2-story w/garage	2003 IRC	2005
New	Approved Basic 04-119755BP	2 story SFR w/attached garage		2003 IRC	Plan:1325 n	2005
New	Approved Basic #04-118889 BP			2-story w/garage	2003 IRC	2005
New	Approved Basic 04-119755BP	2 story SFR w/attached garage		2003 IRC	Plan:1325	2005
New	Approved Basic #04-118889 BP			2-story w/garage	2003 IRC	2005
New	Approved Basic 04-119755BP	2 story SFR w/attached garage		2003 IRC	Plan:1325	2005
New	Approved Basic #04-118889 BP			2-story w/garage	2003 IRC	2005
New	Approved Basic 05-121428 BP	2003 IRC	Plan# 1825	2-story sfr w/attached garage		2005
New	Approved Basic 05-121428 BP	2003 IRC	Plan# 1825	2-story sfr w/attached garage		2005
New	Approved basic 05-120842 BP	2003 IRC	Plan #: 1885	2-story sfr w/attached garage		2005
New	Approved Basic #04-118889 BP			2-story w/garage	2003 IRC	2005
New	Approved Basic #04-118889 BP			2-story w/garage	2003 IRC	2005
New	Approved Basic #04-118889 BP			2-story w/garage	2003 IRC	2005
New	2-story SFR w/garage					2005
New	Approved Basic 04-120090BP	2 story SFR w/attached garage		2003 IRC	Plan:2355-A	2005
New	Approved Basic 04-120821BP	2 Story SFR w/attached garage		2003 IRC	Plan:3271-A	2005

Accessory Dwelling Units

Index # - File Name: 1.0022 - Single Family Dwellings Data\_Snohomish County.pdf

New	Approved	Basic 05-100399BP	2 story SFR w/attached garage	2003 IRC	Plan:2996C	2005
New	Approved	Basic 04-120083BP	2 story SFR w/attached garage	2003 IRC	Plan:2355-B	2005
New	Approved	Basic 04-120087BP	2 story SFR w/attached garage	2003 IRC	Plan:2996-B	2005
New	Approved	Basic 04-120821BP	2 Story SFR w/attached garage	2003 IRC	Plan:3271-A	2005
New	Approved	Basic 05-100399BP	2 story SFR w/attached garage	2003 IRC	Plan:2996C	2005
New	Approved	Basic 04-120086BP	2 story SFR w/attached garage	2003 IRC	Plan:3000-B	2005
New	Approved	Basic 04-120085BP	2 story SFR w/attached garage	2003 IRC	Plan:3271-B	2005
New	Approved	Basic 04-111506BP	Plan: 2863-C Two-story SFR -	2003 IRC		2005
New	Approved	Basic 04-114926BP	2 story SFR w/attached garage	2003 IRC	Plan 2451A & B	2005
New	Approved	Basic 04-116177BP	Builders plan# 2575-A&B	2-Story SFR w/atta		2005
New	Approved	Basic 04-111504BP	Plan: 2863-B Two-story SFR -	2003 IRC		2005
New	Approved	Basic 04-118514BP	2 story SFR w/attached garage	2003 IRC	Plan:2068	2005
New	Approved	Basic 04-115241BP	Plan: 2473 Two-story SFR -	2003 IRC		2005
New	Approved	Basic 05-121062BP	2003 IRC 2 story SFR w/attached garage		Plan:2060	2005
New	Approved	Basic 04-114574BP	2 story SFRw/attached garage	2003 IRC	Plan:1861	2005
New	Approved	Basic 04-114578BP	2 story SFR w/attached garage	2003 IRC	Plan:2978	2005
New	Approved	Basic 04-118514BP	2 story SFR w/attached garage	2003 IRC	Plan:2068	2005
New	Approved	Basic 04-118514BP	2 story SFR w/attached garage	2003 IRC	Plan:2068	2005
New	Approved	Basic 04-120674BP	2 story SFR w/attached garage	2003 IRC	Plan:2440	2005
New	Approved	Basic 04-114578BP	2 story SFR w/attached garage	2003 IRC	Plan:2978	2005
New	Approved	Basic 04-115241BP	Plan: 2473 Two-story SFR -	2003 IRC		2005
New	Approved	Basic 04-115241BP	Plan: 2473 Two-story SFR -	2003 IRC		2005
New	Approved	Basic 04-120674BP	2 story SFR w/attached garage	2003 IRC	Plan:2440	2005
New	Approved	Basic 05-100687BP	2003 IRC		Plan: 2112 A&B	2005
New	Approved	Basic 04-114926BP	2 story SFR w/attached garage	2003 IRC	Plan 2451A & B	2005
New	Approved	Basic 04-114926BP	2 story SFR w/attached garage	2003 IRC	Plan 2451A & B	2005
New	Approved	Basic 05-100687BP	2003 IRC		Plan: 2112 A&B	2005
New	Approved	Basic 05-100687BP	2003 IRC		Plan: 2112 A&B	2005
New	Approved	Basic 04-114926BP	2 story SFR w/attached garage	2003 IRC	Plan 2451A & B	2005
New	Approved	Basic 04-116177BP	Builders plan# 2575-A&B	2-Story SFR w/atta		2005
New	Approved	Basic 04-111506BP	Plan: 2863-C Two-story SFR -	2003 IRC		2005
New	Approved	Basic 04-116177BP	Builders plan# 2575-A&B	2-Story SFR w/atta		2005
New	Approved	Basic 04-114926BP	2 story SFR w/attached garage	2003 IRC	Plan 2451A & B	2005
New	Approved	Basic 05-100687BP	2003 IRC		Plan: 2112 A&B	2005
New	Approved	Basic 04-114926BP	2 story SFR w/attached garage	2003 IRC	Plan 2451A & B	2005
New	Approved	Basic 04-116177BP	Builders plan# 2575-A&B	2-Story SFR w/atta		2005
New	Approved	Basic 04-114926BP	2 story SFR w/attached garage	2003 IRC	Plan 2451A & B	2005
New	Approved	Basic 05-100687BP	2003 IRC		Plan: 2112 A&B	2005
New	Approved	Basic 04-111506BP	Plan: 2863-C Two-story SFR -	2003 IRC		2005
New	Approved	Basic 05-100213BP	2003 IRC		Plan: 2640 A & B Two-story SFR wit	2005
New	Approved	Basic 05-100213BP	2003 IRC		Plan: 2640 A & B Two-story SFR with	2005
New	Approved	Basic 05-116960 BP	2003 IRC	Plan #203 A & B	2 story sfr w/attached ga	2005
New	Approved	Basic 05-100687BP	2003 IRC		Plan: 2112 A&B	2005
New	Approved	Basic 05-100687BP	2003 IRC		Plan: 2112 A&B	2005
New	Approved	Basic 05-100213BP	2003 IRC		Plan: 2640 A & B Two-story SFR	2005
New	Approved	Basic 05-100213BP	2003 IRC		Plan: 2640 A & B Two-story SFR wi	2005
New	Approved	Basic 05-101095BP	2003 IRC		Plan 3387-B 3-car Two-story SFR v	2005

Accessory Dwelling Units

Index # - File Name: 1.0022 - Single Family Dwellings Data\_Snohomish County.pdf

New	Approved	basic 05-124271 BP	2003 IRC	Plan# 2863B 3-car	2-story sfr w/attache	2005
New	Approved	Basic 04-116177BP		Builders plan# 2575-A&B	2-Story SFR w/atta	2005
New	Approved	Basic 05-100687BP		2003 IRC	Plan: 2112 A&B	2005
New	Approved	Basic 05-100213BP	2003 IRC	Plan: 2640 A & B	Two-story SFR wit	2005
New	Approved	basic 05-116239BP	2003 IRC	Plan: 2863C-3 car	2 story sfr w/attached }	2005
New	Approved	Basic 04-111510BP		Plan 3387-A	Two-story SFR - 2003 IRC	2005
New	Approved	Basic 04-113874PB	Two Story SFR w/attached 2 Car Garage	2003 IRC	Builder	2005
New	Approved	Basic 04-116177BP		Builders plan# 2575-A&B	2-Story SFR w/atta	2005
New	Approved	Basic 04-114926BP	2 story SFR w/attached garage	2003 IRC	Plan 2451A & B	2005
New	Approved	Basic 05-100687BP		2003 IRC	Plan: 2112 A&B	2005
New	Approved	Basic 04-116427BP		Plan: 3512 A & B	Two-story SFR with attache	2005
New	Approved	Basic 05-116239BP	2003 IRC	Plan: 2863C-3 car	2 story sfr w/attached }	2005
New		2 story SFR w/attached garage	2003 IRC	3016A		2005
New		2 story SFR w/attached garage	2003 IRC			2005
New	Approved	Basic 05-100740BP	Two Story SFR with Attached Garage	2003 IRC	Plan 327	2005
New	Approved	Basic 04-120084BP	2 story SFR w/attached garage	2003 IRC	Plan:3000A	2005
New	Approved	Basic 04-120086BP	2 story SFR w/attached garage	2003 IRC	Plan:3000-B	2005
New	Approved	Basic 05-101967BP	2003IRC	Plan: 2842-A2	2 story SFR w/atta	2005
New	Approved	Basic 05-100740BP	Two Story SFR with Attached Garage	2003 IRC	Plan 327	2005
New	Approved	Basic 04-120086BP	2 story SFR w/attached garage	2003 IRC	Plan:3000-B	2005
New	Approved	Basic 04-120087BP	2 story SFR w/attached garage	2003 IRC	Plan:2996-B	2005
New	Approved	Basic 04-120822BP	2 Story w/attached garage -	2003 IRC	Plan:2535-C	2005
New	Approved	Basic 05-100399BP	2 story SFR w/attached garage	2003 IRC	Plan:2996C	2005
New	Approved	Basic 04-120085BP	2 story SFR w/attached garage	2003 IRC	Plan:3271-B	2005
New	Approved	Basic 04-120091BP	2 story SFR w/attached garage	2003 IRC	Plan:2996-A	2005
New	Approved	Basic 04-120085BP	2 story SFR w/attached garage	2003 IRC	Plan:3271-B	2005
New	Approved	Basic 05-101967BP	2003IRC	Plan: 2842-A2	2 story SFR w/atta	2005
New	Approved	Basic 04-120823BP	2 story w/attached garage	2003 IRC	Plan:2535B	2005
New	Approved	Basic 04-120087BP	2 story SFR w/attached garage	2003 IRC	Plan:2996-B	2005
New	Approved	Basic 05-100740BP	Two Story SFR with Attached Garage	2003 IRC	Plan 327	2005
New	Approved	Basic 05-101967BP	2003IRC	Plan: 2842-A2	2 story SFR w/atta	2005
New	Approved	Basic 04-120091BP	2 story SFR w/attached garage	2003 IRC	Plan:2996-A	2005
New	Approved	Basic 05-100740BP	Two Story SFR with Attached Garage	2003 IRC	Plan 327	2005
New	Approved	Basic 04-120822BP	2 Story w/attached garage -	2003 IRC	Plan:2535-C	2005
New	Approved	Basic 04-120091BP	2 story SFR w/attached garage	2003 IRC	Plan:2996-A	2005
New	Approved	Basic 04-120085BP	2 story SFR w/attached garage	2003 IRC	Plan:3271-B	2005
New	Approved	Basic 04-120821BP	2 Story SFR w/attached garage	2003 IRC	Plan:3271-A	2005
New	Approved	Basic 05-100399BP	2 story SFR w/attached garage	2003 IRC	Plan:2996C	2005
New	Approved	Basic 04-120083BP	2 story SFR w/attached garage	2003 IRC	Plan:2355-B	2005
New	Approved	Basic 04-120086BP	2 story SFR w/attached garage	2003 IRC	Plan:3000-B	2005
New		2 story SFR w/attached garage	2003 IRC	Plan:2741C		2005
New	Approved	Basic 04-120084BP	2 story SFR w/attached garage	2003 IRC	Plan:3000A	2005
New	Approved	Basic 04-120090BP	2 story SFR w/attached garage	2003 IRC	Plan:2355-A	2005
New	Approved	Basic 04-120087BP	2 story SFR w/attached garage	2003 IRC	Plan:2996-B	2005
New	Approved	Basic 05-100740BP	Two Story SFR with Attached Garage	2003 IRC	Plan 327	2005
New	Approved	Basic 04-120091BP	2 story SFR w/attached garage	2003 IRC	Plan:2996-A	2005
New	Approved	Basic 05-100399BP	2 story SFR w/attached garage	2003 IRC	Plan:2996C	2005

Accessory Dwelling Units

Index # - File Name: 1.0022 - Single Family Dwellings Data\_Snohomish County.pdf

New	Two-story SFR - 2003 IRC					2005
New	Approved Basic 04-121279BP	Rambler style SFR w/garage	2003 IRC	Plan:2608		2005
New	Approved Basic 05-100011BP	2 stroy SFR w/attached garage	2003 IRC	Plan:2892		2005
New	Approved Basic 05-101295BP		2003 IRC	Plan:2774B		2005
New	Approved Basic 05-101298BP		2003 IRC	Plan:2958		2005
New	Two-story SFRw/attached garage		2003 IRC	Plan ;1650	PLAN CHECK ONLY	2005
New	2-story Duplex w/garage		2003 IRC	Plan:2018	PLAN CHECK ONLY	2005
New	Two-story SFR w/attached garage		2003 IRC	Builder s Plan: 1650 Duplex A	PLAN CHEC	2005
New	27 x 48 - 2004 - Marlette Mobile Home.					2005
New	Two-story SFR with attached two-car garage - 2003 IRC					2005
New	Rambler style w/garage					2005
New	Approved Basic 04- 117174BP			Builders Plan #2952	2 Story w/attached	2005
New	Approved Basic 04-121279BP	Rambler style SFR w/garage	2003 IRC	Plan:2608		2005
New	Approved Basic 05-118728BP		2003 IRC	2 story SFR w/attached garage	Plan:3;	2005
New	Approved Basic 05-118728BP		2003 IRC	2 story SFR w/attached garage	Plan:3;	2005
New	Approved Basic 05-118728BP		2003 IRC	2 story SFR w/attached garage	Plan:3;	2005
New	Approved Basic 05-118736BP		2003 IRC	2 story SFR w/attached garage	Plan:2999w/	2005
New	Approved Basic 05-118728BP		2003 IRC	2 story SFR w/attached garage	Plan:3;	2005
New	Approved Basic 05-118736BP		2003 IRC	2 story SFR w/attached garage	Plan:2999w/	2005
New	2 story SFR w/attached garage			Plan:Poulsbo A 3 Car		2005
New	2-story sfr w/attached garage					2005
New	2 story SFR w/attached garage		2003 IRC	Paln:2706B		2005
New	Approved Basic 05-118728BP		2003 IRC	2 story SFR w/attached garage	Plan:3;	2005
New	2 story SFR w/attached garage		2003 IRC	Plan:3165B		2005
New	2 story SFR w/attached garage		2003 IRC	Plan:2706A		2005
New	Approved Basic 05-118736BP		2003 IRC	2 story SFR w/attached garage	Plan:2999w/	2005
New	Approved Basic 05-118741BP		2003 IRC	2 story SFR w/attached garage	Plan:2786w/lof	2005
New	Approved Basic 05-118734BP		2003 IRC	2 story SFR w/attached garage	Plan:2999	2005
New	Approved Basic 05-118741BP		2003 IRC	2 story SFR w/attached garage	Plan:2786\	2005
New	2 story SFR w/attached garage		2003 IRC	Plan:Richmond A 3-car		2005
New	2 story SFR w/attached garage		2003 IRC	Plan:Rcihmond B 3- car		2005
New	Two-story SFR with attached garage - 2003 IRC			Plan: Preston B		2005
New	2 story single family residence with 3 car garge					2005
New	2 story SFR w/attached garage		2003 IRC	Plan:Presten A		2005
New	2-story SFR w/garage					2005
New	2-story sfr w/attached garage					2005
New	Two story SFR			Builder s Plan:Breckendale B		2005
New	2-Story SFR w/attached garage.					2005
New	2-story sfr w/attached garage					2005
New	2-story sfr w/attached garage					2005
New	Approved Basic 05-118736BP		2003 IRC	2 story SFR w/attached garage	Plan:2999w/	2005
New	Approved Basic 05-118728BP		2003 IRC	2 story SFR w/attached garage	Plan:3;	2005
New	Approved Basic 05-118728BP		2003 IRC	2 story SFR w/attached garage	Plan:3;	2005
New	Approved Basic 05-118741BP		2003 IRC	2 story SFR w/attached garage	Plan:2786\	2005
New	Approved Basic 05-118736BP		2003 IRC	2 story SFR w/attached garage	Plan:2999w/	2005
New	Approved Basic 05-118728BP		2003 IRC	2 story SFR w/attached garage	Plan:3;	2005
New	Approved Basic 05-118732BP		2003 IRC	2 story SFR w/attached garage	Plan:3007	2005

Accessory Dwelling Units

Index # - File Name: 1.0022 - Single Family Dwellings Data\_Snohomish County.pdf

New	Approved Basic 05-118728BP	2003 IRC	2 story SFR w/attached garage	Plan:3;	2005
New	2 story SFR w/attached garage	2003 IRC	Plan:Richmond		2005
New	2 story SFR w/attached garage	2003 IRC	Plan:Prescott-A		2005
New	2 story SFR w/attached garage	2003 IRC	Plan:Prescott B		2005
New	2 story SFR w/attached garage	2003 IRC	Plan:Sierra 3 car		2005
New	Approved Basic 05-118728BP	2003 IRC	2 story SFR w/attached garage	Plan:3;	2005
New	Approved Basic 05-118736BP	2003 IRC	2 story SFR w/attached garage	Plan:2999w/	2005
New	Approved Basic 05-118736BP	2003 IRC	2 story SFR w/attached garage	Plan:2999w/	2005
New	Approved Basic 05-118728BP	2003 IRC	2 story SFR w/attached garage	Plan:3;	2005
New	2 story SFR w/attached garage	2003 IRC	Plan:2505C		2005
New	Approved Basic 05-118728BP	2003 IRC	2 story SFR w/attached garage	Plan:3;	2005
New	Approved Basic 05-118736BP	2003 IRC	2 story SFR w/attached garage	Plan:2999w/	2005
New	Approved Basic 05-118728BP	2003 IRC	2 story SFR w/attached garage	Plan:3;	2005
New	2 story SFR w/attached garage	2003 IRC	Plan:Waterford B		2005
New	2 - story sfr w/attached garage				2005
New	Two-story sfr with attached garage				2005
New	2 story SFR w/attached garage	2003 IRC	Plan:Manchester A		2005
New	2 story SFR w/attached garage	2003 IRC	Plan:Waterford		2005
New	2 story SFR w/attached garage	2003 IRC	Plan:Olympic A 3-car		2005
New	2 story SFR w/attached garage	2003 IRC	Plan:Sierra 3-car		2005
New	2 story SFR w/attached garage	2003 IRC	Plan:2999		2005
New	2 story SFR w/attached garage	2003 IRC	Plan:2786		2005
New	2 story SFR w/attached garage	2003 IRC	Plan:3203B		2005
New	2 story SFR w/attached garage	2003 IRC	Plan:2999A		2005
New	2 story SFR w/attached garage	2003 IRC	Plan:2999C		2005
New	2 story SFR w/attached garage	2003 IRC	Plan:3203C		2005
New	2-story sfr w/attached garage				2005
New	2 story sfr w/attached garage				2005
New	2 story SFR w/attached garage	2003 IRC	Plan:Sierra A		2005
New	2 story SFR w/attached garage	2003 IRC	Plan:Sierra 3-Car w/nook		2005
New	2 story SFR w/attached garage	2003 IRC			2005
New	2 story SFR w/attached garage	2003 IRC			2005
New	2 story SFR w/attached garage	2003 IRC			2005
New	2 story SFR w/attached garage	2003 IRC	Plan:Prescott		2005
New	2 story SFR w/attached garage				2005
New	2-story sfr w/attached garage	2003 IRC	Plan:Preston A		2005
New	Approved Basic 05-118736BP	2003 IRC	2 story SFR w/attached garage	Plan:2999w/	2005
New	Approved Basic 05-118736BP	2003 IRC	2 story SFR w/attached garage	Plan:2999w/	2005
New	2 story SFR w/attached garage	2003 IRC	Plan:3165A		2005
New	Approved Basic 05-117036 BP	2003 IRC	Plan: Mary Ann		2005
New	2 story SFR w/attached garage	2003 IRC			2005
New	Approved Basic 05-118728BP	2003 IRC	2 story SFR w/attached garage	Plan:3;	2005
New	Two-story SFR		Builders Plan: Preston B		2005
New	2 story SFR w/attached garage	2003 IRC	Plan:2706A		2005
New	2 story SFR w/attached garage	2003 IRC	Plan:2999A		2005
New	2 story SFR w/attached garage	2003 IRC	Plan:3007		2005

Accessory Dwelling Units

Index # - File Name: 1.0022 - Single Family Dwellings Data\_Snohomish County.pdf

New	2 story sfr w/attachec garage	2003 IRC	Plan:3203		2005
New	2 story SFR w/attached garage	2003 IRC	Plan:2786		2005
New	Approved Basic 05-118736BP	2003 IRC	2 story SFR w/attached garage	Plan:2999w/	2005
New	Approved Basic 05-118740BP	2003 IRC	2 story SFR w/attached garage	Plan:2786	2005
New	2 story SFR w/attached garage	2003 IRC	Plan:2999 C		2005
New	2 story SFR w/attached garage	2003 IRC	Plan:3203 A		2005
New	2 story SFR w/attached garage	2003 IRC	Plan:2786B		2005
New	2 story SFR w/attached garage	2003 IRC	Plan:2786A		2005
New	Approved Basic 05-118728BP	2003 IRC	2 story SFR w/attached garage	Plan:3;	2005
New	Approved Basic 05-118728BP	2003 IRC	2 story SFR w/attached garage	Plan:3;	2005
New	Approved Basic 05-118734BP	2003 IRC	2 story SFR w/attached garage	Plan:2999	2005
New	Approved Basic 05-118728BP	2003 IRC	2 story SFR w/attached garage	Plan:3;	2005
New	Approved Basic 05-118736BP	2003 IRC	2 story SFR w/attached garage	Plan:2999w/	2005
New	Approved Basic 05-118728BP	2003 IRC	2 story SFR w/attached garage	Plan:3;	2005
New	2 story w/ attached 3 car garage				2005
New	Construct 800 sf garage; with 800 sf apartment; with 157 sf covered porch				2005
New	Approved Basic 04-116621BP	2 Story SFR w/attached garage	2003 IRC	Plan:1909	2005
New	Approved Basic 04-118845BP	2 story SFR w/attached garage	2003 IRC	Plan:2294	2005
New	Approved Basic 04-111161BP		Plan: 1932 Two-story SFR - 2003 IRC		2005
New	Approved Basic 05-101228BP		2004 IRC	Plan:2294HIP	2005
New	Approved Basic 04-116621BP	2 Story SFR w/attached garage	2003 IRC	Plan:1909	2005
New	Approved Basic 04-111161BP		Plan: 1932 Two-story SFR - 2003 IRC		2005
New	Approved Basic 05-101228BP		2004 IRC	Plan:2294HIP	2005
New	Approved Basic 04-116621BP	2 Story SFR w/attached garage	2003 IRC	Plan:1909	2005
New	Approved Basic 04-118845BP	2 story SFR w/attached garage	2003 IRC	Plan:2294	2005
New	Approved Basic 04-120167BP	2 story SFR w/attached garage	2003 IRC	Plan:2597	2005
New	Approved Basic 04-116621BP	2003 IRC	Plan:1909	2 story SFR w/attached garage	2005
New	Approved Basic 04-120167BP	2 story SFR w/attached garage	2003 IRC	Plan:2597	2005
New	Approved Basic 04-118845BP	2 story SFR w/attached garage	2003 IRC	Plan:2294	2005
New	Approved Basic 05-101228BP		2004 IRC	Plan:2294HIP	2005
New	Approved Basic 04-111161BP		Plan: 1932 Two-story SFR - 2003 IRC		2005
New	Approved Basic 04-116621BP	2 Story SFR w/attached garage	2003 IRC	Plan:1909	2005
New	Approved Basic 04-111161BP		Plan: 1932 Two-story SFR - 2003 IRC		2005
New	Approved Basic 05-101228BP		2004 IRC	Plan:2294HIP	2005
New	Approved Basic 04-111161BP	2003 IRC	Plan: 1932 Two-story SFR w/attached ga		2005
New	Approved Basic 04-120167BP	2 story SFR w/attached garage	2003 IRC	Plan:2597	2005
New	Approved Basic 05-101228BP		2004 IRC	Plan:2294HIP	2005
New	Approved Basic 04-118845BP	2 story SFR w/attached garage	2003 IRC	Plan:2294	2005
New	Approved Basic 04-120167BP	2 story SFR w/attached garage	2003 IRC	Plan:2597	2005
New	Approved Basic 04-111161BP		Plan: 1932 Two-story SFR - 2003 IRC		2005
New	Approved Basic 05-100536BP	2003 IRC		Plan: 2235	2005
New	Approved Basic 04-120827BP		Plan: 2241C3F-2 Two-story SFR with attac		2005
New	Approved Basic 04-120563BP		Plan: M2455A3F-0 Two-story SFR with attache		2005
New	Approved Basic 04-120841BP		Plan: M2650A350 Two-story SFR with attac		2005
New	Approved Basic 05-100536BP		Plan: 2235		2005
New	Approved Basic 04-120834BP		Plan: M2605A350 Two-story SFR with a		2005
New	Approved Basic 04-120841BP		Plan: M2650A350 Two-story SFR with attac		2005



Accessory Dwelling Units

Index # - File Name: 1.0022 - Single Family Dwellings Data\_Snohomish County.pdf

New	Approved Basic 04-120567BP		Plan: M2535A3F-0	Two-story SFR with attac	2005
New	Approved Basic 04-121229BP		Plan: R2035A3F-O	Rambler Style SFR with a	2005
New	Approved Basic 04-120543BP		Plan: M2330C3F0	Two-Story SFR with attache	2005
New	Rambler with Attached Garage	2003 IRC			2005
New	Two story SFR with attached Garage				2005
New	Approved Basic 04-120109-BP	2 story SFR w/attached garage	2003 IRC	Bldrs. Plan: Jos	2005
New	Approved Basic 04-118633BP	2 story SFR w/attached garage	2003 IRC	Plan: Autumnwood	2005
New	Approved Basic 04-118633BP	2 story SFR w/attached garage	2003 IRC	Plan: Autumnwood	2005
New	Approved Basic 04-118633BP	2 story SFR w/attached garage	2003 IRC	Plan: Autumnwood	2005
New	Two-story sfr with garage				2005
New	Approved Basic 04-119745BP	2 story SFR w/attached garage	2003 IRC	Plan:B1	2005
New	Approved Basic 04-117788BP	2 story SFR w/ attached garage	2003 IRC	Plan:B-2	2005
New	Two Story with attached Garage				2005
New	Approved Basic 04-117788BP	2 story SFR w/ attached garage	2003 IRC	Plan:B-2	2005
New	Approved Basic 04-119745BP	2 story SFR w/attached garage	2003 IRC	Plan:B1	2005
New	Approved Basic 04-119749BP	2 story SFR w/attached garage	2003 IRC	Plan:D	2005
New	Approved Basic 04-119745BP	2 story SFR w/attached garage	2003 IRC	Plan:B1	2005
New	Approved Basic 04-117788BP	2 story SFR w/ attached garage	2003 IRC	Plan:B-2	2005
New	Approved Basic 04-119749BP	2 story SFR w/attached garage	2003 IRC	Plan:D	2005
New	Approved Basic 04-117788BP	2 story SFR w/ attached garage	2003 IRC	Plan:B-2	2005
New	Approved Basic 04-119749BP	2 story SFR w/attached garage	2003 IRC	Plan:D	2005
New	Approved Basic 04-119745BP	2 story SFR w/attached garage	2003 IRC	Plan:B1	2005
New	Two story SFR with attached Garage				2005
New	Approved Basic 04-119749BP	2 story SFR w/attached garage	2003 IRC	Plan:D	2005
New	Approved Basic 04-117788BP	2 story SFR w/ attached garage	2003 IRC	Plan:B-2	2005
New	Approved Basic 04-119745BP	2 story SFR w/attached garage	2003 IRC	Plan:B1	2005
New	Approved Basic 04-117788BP	2 story SFR w/ attached garage	2003 IRC	Plan:B-2	2005
New	Two-story SFR			Builders Plan: A29	2005
New	Approved basic 05-116215 BP	2003 IRC	Plan: G	2 story sfr w/attached garage	2005
New	Approved basic 05-116215 BP	2003 IRC	Plan: G	2 story sfr w/attached garage	2005
New	Approved Basic 05-116215 BP	2003 IRC	Plan: G	2 story sfr w/attached garage	2005
New	Approved Basic 05-116215 BP	2003 IRC	Plan: G	2 story sfr w/attached garage	2005
New	Approved Basic 05-116215 BP	2003 IRC	Plan: G	2 story sfr w/attached garage	2005
New	Approved Basic 04-120532BP	2 story SFR w/attached garage	2003 IRC	Plan:124-I	2005
New	Approved Basic 04-120532BP	2 story SFR w/attached garage	2003 IRC	Plan:124-I	2005
New	Approved Basic 04-120532BP	2 story SFR w/attached garage	2003 IRC	Plan:124-I	2005
New	Approved Basic 04-120532BP	2 story SFR w/attached garage	2003 IRC	Plan:124-I	2005
New	Approved Basic 04-120532BP	2 story SFR w/attached garage	2003 IRC	Plan:124-I	2005
New	Two-story sfr with attached garage				2005
New	Two story sfr with garage				2005
New	2 story SFR w/attached garage	2003 IRC			2005
New	2 story SFR w/attached garage	2003 IRC			2005
New	2 story SFR w/attached garage	2003 IRC			2005
New	2 story SFR w/attached garage	2003 IRC			2005
New	2 story SFR w/attached garage	2003 IRC			2005
New	2 story SFR w/attached garage	2003 IRC			2005
New	2 story SFR w/attached garage	2003 IRC			2005
New	Duplex				2005

Accessory Dwelling Units

Index # - File Name: 1.0022 - Single Family Dwellings Data\_Snohomish County.pdf

New	Double Wide Mobile Home for guest house				2005
New	Approved Basic 04-116301BP	2 story SFR w/attached garage	2003 IRC	Plan:2590	2005
New	2-story sfr w/attached garage				2005
New	Approved Basic 04-116301BP	2 story SFR w/attached garage	2003 IRC	Plan:2590	2005
New	Approved Basic 04- 119008BP		Plan: 2488	Two-story SFR with attached 2-	2005
New	Approved Basic 04-115758BP		Plan: 2922	Two-story SFR - 2003 IRC	2005
New	Approved Basic 04- 118786BP		Plan: 2690	Two-story SFR with attached 3-ca	2005
New	Approved Basic 04-116584BP	2 story SFR w/attached garage	2003 IRC	Plan:2338A3FT-	2005
New	Approved Basic 04-118786BP		Plan: 2690	Two-story SFR with attached 3-ca	2005
New	Approved Basic 04-119037BP	1 story SFR w/attached garage	2003 IRC	Plan:2095	2005
New	Two story SFR with unfinished basement & attached garage				2005
New	Two story SFR with attached garage				2005
New	Approved Basic 04-115758BP		Plan: 2922	Two-story SFR - 2003 IRC	2005
New	Approved Basic #05-100005BP	Two Story SFR with Attached Garage		2003 IRC	2005
New	Approved Basic #05-100005BP	Two Story SFR with Attached Garage		2003 IRC	2005
New	2-story SFR w/garage				2005
New	2 story single family				2005
New	Two-story SFR with unfinished basement - 2003 IRC				2005
New	2-story SFR w/garage				2005
New	1870 sq ft SFR with 562 sq ft Garage				2005
New	One-story SFR with garage				2005
New	Approved Basic 05-122311 BP	2003 IRC	Rambler w/attached garage	Plan:2622	2005
New	Two story SFR with attached garage				2005
New	Two-story SFR with unfinished basement & attached garage - 2003 IRC				2005
New	Approved Basic 05-116166BP	2003 IRC		Plan: Tyhaka	2005
New	Approved Basic 05-101953BP	2003 IRC	2 story SFR w/attached garage	Plan:Rainier	2005
New	Approved Basic 04-119639BP		Plan: Eagle-1	Rambler-style SFR with attach	2005
New	Approved Basic 04-113768BP	2 story SFR w/attached garage	2003 IRC	Plan:3040	2005
New	Two-story SFR w/unfin basement			Builders Plan : Willow	2005
New	732 unfinished to finish basement				2005
New	Single Family Residence				2005
New	2-story w/unfinished basement & attached garage				2005
New	Two story SFR with Unfinished Basement & attached Garage				2005
New	Rambler style SFR w/attached garage				2005
New	Two-story sfr with garage.				2005
New	2-story SFR w/garage				2005
New	2 story single family residence with 3 car garage				2005
New	2 story single family (2394 sf) residence with attached garage				2005
New	2-story SFR w/attached garage				2005
New	2 - story sfr w/attached garage				2005
New	2 - story SFR w/attached garage				2005
New	2-story SFR/garage				2005
New	2-story sfr w/attached garage				2005
New	Two-story sfr with garage				2005
New	2-story SFR w/garage				2005
New	2 - story sfr w/attached garage				2005
New	2 - story SFR w/attached garage				2005

Accessory Dwelling Units

Index # - File Name: 1.0022 - Single Family Dwellings Data\_Snohomish County.pdf

New	Two story SFR with attached garage				2005
New	2-Story SFR w/attached garage				2005
New	Approved Basic 04-117114BP	Plan: 1538	Rambler with attached garage - 20		2005
New	Approved Basic # 04-116650BP		Plan:2360 Two Story SFR with Att		2005
New	Approved Basic #04-116771 BP	2-story w/attached garage	2003 IRC	Plan:2117	2005
New	Approved Basic 04-121488BP	2 story SFR wfinished basement & attached garage	2003 IRC		2005
New	Approved Basic 04-117114BP	Plan: 1538	Rambler with attached garage - 20		2005
New	Approved Basic 04-121485BP	2 Story SFR w/attached garage	2003 IRC	Plan:2460	2005
New	Approved Basic 04-121485BP	2 Story SFR w/attached garage	2003 IRC	Plan:2460	2005
New	Approved Basic #04-116770 BP	Plan:2119	2-story w/attached garage		2005
New	Approved Basic # 04-116650BP		Plan:2360 Two Story SFR with Att		2005
New	Rambler style w/garage				2005
New	Approved Basic 04-121488BP	2 story SFR wfinished basement & attached garage	2003 IRC		2005
New	Daylight Basement rambler w/semi-finished basement & attached garage.				2005
New	Approved Basic 04-119788BP	Plan 2184	Quad level SFR with semi-fini		2005
New	Approved Basic 04-119145BP	Plan 1786	Two-story SFR with attached		2005
New	Approved Basic 04-120322BP	2 story SFR w/attached garage	2003 IRC	Plan:923AB	2005
New	2-story SFR w/garage				2005
New	2 story SFR w/attahed garage	2003 IRC	Plan:5025-B		2005
New	28x56, 2004 Fleetwood				2005
New	2 story SFR w/attached garage	2003 IRC	Plan:4013-A		2005
New	2 story SFR w/attached garage	2003 IRC	Plan:4010-C		2005
New	2 story sfr w/attached garage				2005
New	2 story SFR w/attached garage	2003 IRC	Plan:Waterford B-4 car		2005
New	2 story SFR w/attached garage	2003 IRC	Plan:5020F-C French Door		2005
New	2 story SFR w/attached garage	2003 IRC	Plan:3105-A		2005
New	2 story SFR w/attached garage	2003 IRC	Plan:4012RK		2005
New	2 story SFR w/attahed garage	2003 IRC	Plan:5025-B		2005
New	Approved Basic 04-116007BP	2 story SFR w/attached garage	2003 IRC	Plan:2242	2005
New	Approved Basic 04-1125956BP	2 story SFR w/attached garage	2003 IRC	Plan:2054	2005
New	Approved Basic 04-115956BP	2 story SFR w/attached garage	2003 IRC	Plan:2054	2005
New	Approved Basic 04 -119331 BP		Two-story SFRw/attached garage		2005
New	Approved Basic 04-116008BP	2 story SFR w/attached garage	2003 IRC	Plan:2160	2005
New	2 story SFR w/ attached garage	2003 IRC	Plan:4012B-C		2005
New	2 story SFR w/attached garage	2003 IRC	Plan:3006-C		2005
New	2 story SFR w/attached garage	2003 IRC	Plan:4013B-A		2005
New	2 story SFR w/attached garage	2003 IRC	Plan:3006		2005
New	2 story SFR w/attached garage	2003 IRC	Plan:3105B		2005
New	2 story SFR w/attached garage	2003 IRC	Plan:4012-B		2005
New	Approved Basic 04 -119331 BP		Two-story SFRw/attached garage		2005
New	Approved Basic 04-116007BP	2 story SFR w/attached garage	2003 IRC	Plan:2242	2005
New	Approved Basic 04-115956BP	2 story SFR w/attached garage	2003 IRC	Plan:2054	2005
New	Approved Basic 04 -119331 BP		Two-story SFRw/attached garage		2005
New	Approved Basic 04 -119331 BP		Two-story SFRw/attached garage		2005
New	2 story sfr w/attached garage				2005
New	Approved Basic 04-120673BP	Plan: 5039 AM	Two-story SFR with 3-car/		2005
New	Approved Basic 05-100211BP	2003 IRC	Plan:937AB	2 story w/attached	2005

Accessory Dwelling Units

Index # - File Name: 1.0022 - Single Family Dwellings Data\_Snohomish County.pdf

New	Approved Basic 04-120673BP		Plan: 5039 AM	Two-story SFR with 3-car/	2005
New	Approved Basic 04-116377BP	2 story SFR w/attached garage	2003 IRC	Plan:5055A	2005
New	Approved Basic 04-120673BP		Plan: 5039 AM	Two-story SFR with 3-car/	2005
New	Approved Basic 04-115973BP	2 sztory SFR w/attached garage	2003 IRC	Plan:4855AB	2005
New	Approved Basic 04-120322BP	2 story SFR w/attached garage	2003 IRC	Plan:923AB	2005
New	Approved Basic 05-100211BP	2 story w/attached garage	2003 IRC	Plan:!	2005
New	Approved Basic 04-120322BP	2 story SFR w/attached garage	2003 IRC	Plan:923AB	2005
New	Approved Basic 04-120322BP	2003 IRC	Plan:923AB	2 story SFR w/attached garage	2005
New	2-story w/garage				2005
New	2 story SFR w/attached garage	2003 IRC	Plan: Waterford A-4 car		2005
New	Two-story sfr with attached garage				2005
New	2 story SFR w/attached garage	2003 IRC	Plan:Waterford B		2005
New	2 story SFR w/attached garage	2003 IRC	Plan:Waterford B		2005
New	2-story w/ attchd. 3 car garage				2005
New	Two-story sfr with attached garage				2005
New	Two story SFR with attached Garage				2005
New	Two-story sfr with attached garage				2005
New	2 story sfr w/attached garage				2005
New	2-Story SFR w/attached garage				2005
New	2-story w/garage				2005
New	Approved Basic 05-100211BP	2003IRC	Plan:937AB	2 story w/attache	2005
New	2-story SFR w/ semi-finished basement				2005
New	Approved Basic 05-100213BP	2003 IRC	Plan: 2640 A & B	Two-story S	2005
New	Two story SFR with attached Garage				2005
New	Two Story SFR with Attached Garage				2005
New	Two Story SFR with Attached Garage				2005
New	2-story sfr w/attached garage				2005
New	Two-story SFR		Builders Plan: Waterford B		2005
New	2-Story SFR w/attached garage.				2005
New	Approved Basic 04-120673BP		Plan: 5039 AM	Two-story SFR with 3-car/	2005
New	Approved Basic 04-120322BP	2 story SFR w/attached garage	2003 IRC	Plan:923AB	2005
New	Approved Basic 04-118454BP	2 story SFR w/attached garage	2003 IRC	Plan:4855AB	2005
New	Approved Basic 04-117573BP		Plan: 5060 B	Two-story SFR with attached gar	2005
New	Approved Basic 04-118454BP	2 story SFR w/attached garage	2003 IRC	Plan:4855AB	2005
New	Approved Basic 04-120673BP		Plan: 5039 AM	Two-story SFR with 3-car/	2005
New	Approved Basic 04-120322BP	2003 IRC	Plan:923AB	2 story SFR w/attached garage	2005
New	Approved Basic 04-118454BP	2 story SFR w/attached garage	2003 IRC	Plan:4855AB	2005
New	Approved Basic 04-117938BP	2 story SFR w/attached garage	2003 IRC	Plan:F5055A	2005
New	Approved Basic 04-117574BP		Plan: 5060A	Two-story SFR with attached gar	2005
New	Approved Basic 04-120673BP		Plan: 5039 AM	Two-story SFR with 3-car/	2005
New	Approved Basic 04-116377BP	2 story SFR w/attached garage	2003 IRC	Plan:5055A	2005
New	Approved Basic 05-101022BP		2003 IRC	Plan:5069A	2005
New	Approved Basic 04-117574BP		Plan: 5060A	Two-story SFR with attached gar	2005
New	Approved Basic 04-117574BP		Plan: 5060A	Two-story SFR with attached gar	2005
New	Approved Basic 04-117108BP		Plan: 5038 AM	Two-story SFR with attached ga	2005
New	Approved Basic 04-117938BP	2 story SFR w/attached garage	2003 IRC	Plan:F5055A	2005
New	Approved Basic 04-117574BP		Plan: 5060A	Two-story SFR with attached gar	2005

Accessory Dwelling Units

Index # - File Name: 1.0022 - Single Family Dwellings Data\_Snohomish County.pdf

New	Approved Basic 05-101022BP	2003 IRC	Plan:5069A	2005
New	Approved Basic 04-117573BP	Plan: 5060 B	Two-story SFR with attached garage	2005
New	Approved Basic 04-117108BP	Plan: 5038 AM	Two-story SFR with attached garage	2005
New	Approved Basic 04-120673BP	Plan: 5039 AM	Two-story SFR with 3-car garage	2005
New	Approved Basic 04-117574BP	Plan: 5060A	Two-story SFR with attached garage	2005
New	Approved Basic 04-115134BP	2 story SFR w/attached garage	2003 IRC Plan:50090-A3	2005
New	Approved Basic 04-114424BP	Plan: 50050-A4T	Two-story SFR - 2003 IRC	2005
New	Approved Basic 04-115849BP	2 story SFR w/attached garage	2003 IRC Plan:40030-A3T	2005
New	Approved Basic 04-114427BP	Plan: 50080-A3	Two-story SFR - 2003 IRC	2005
New	Approved Basic 04-114424BP	Plan: 50050-A4T	Two-story SFR - 2003 IRC	2005
New	Approved Basic 04-114427BP	Plan: 50080-A3	Two-story SFR - 2003 IRC	2005
New	Approved Basic 04-115137BP	2 story SFR w/attached garage	2003 IRC Plan:50070-A3T	2005
New	Two story SFR with attached 3 car garage			2005
New	Approved Basic 04-112274BP	2 story SFR w/ attached garage	2003 IRC Plan#2205 A & B	2005
New	Approved Basic 04-112274BP	2 story SFR w/ attached garage	2003 IRC Plan#2205 A & B	2005
New	Approved Basic 04-116418BP	Plan: 2149 A & B	Two-story SFR with attached garage	2005
New	Approved Basic 04-112274BP	2 story SFR w/ attached garage	2003 IRC Plan#2205 A & B	2005
New	Approved Basic 04-112274BP	2 story SFR w/ attached garage	2003 IRC Plan#2205 A & B	2005
New	Approved Basic 05-100213BP	2003 IRC	Plan: 2640 A & B Two-story SFR with	2005
New	Approved Basic 05-100213BP	2003 IRC	Plan: 2640 A & B Two-story SFR with	2005
New	Approved Basic 04-116177BP		Builders plan# 2575-A&B 2-Story SFR w/attached	2005
New	Approved Basic 04-114574BP	2 story SFRw/attached garage	2003 IRC Plan:1861	2005
New	Approved Basic 04-115241BP	Plan: 2473	Two-story SFR - 2003 IRC	2005
New	Approved Basic 04-115238BP	2003 IRC	Plan: 2201 Two-story SFR	2005
New	Approved Basic 05-116991BP	2003 IRC	Plan:2068B	2005
New	Approved Basic 04-115241BP	Plan: 2473	Two-story SFR - 2003 IRC	2005
New	Approved Basic 05-116992BP	2003 IRC	Plan:2068C elevation	2005
New	Approved Basic 04-115241BP	Plan: 2473	Two-story SFR - 2003 IRC	2005
New	Approved Basic 04-114578BP	2 story SFR w/attached garage	2003 IRC Plan:2978	2005
New	Approved Basic 04-115241BP	Plan: 2473	Two-story SFR - 2003 IRC	2005
New	Approved Basic 04-115241BP	Plan: 2473	Two-story SFR - 2003 IRC	2005
New	Approved Basic 04-118514BP	2 story SFR w/attached garage	2003 IRC Plan:2068	2005
New	2 story SFR w/attached garage	2003 IRC	Plan:5022 F-B	2005
New	Approved Basic 04-115241BP	Plan: 2473	Two-story SFR - 2003 IRC	2005
New	Approved Basic 04-118514BP	2 story SFR w/attached garage	2003 IRC Plan:2068	2005
New	Approved Basic 04-115241BP	Plan: 2473	Two-story SFR - 2003 IRC	2005
New	Approved Basic 04-115241BP	Plan: 2473	Two-story SFR - 2003 IRC	2005
New	Approved Basic 04-120674BP	2003 IRC	Plan:2440 2 story SFR w/attached garage	2005
New	Approved Basic 04-115241BP	Plan: 2473	Two-story SFR - 2003 IRC	2005
New	Approved Basic 04-118514BP	2 story SFR w/attached garage	2003 IRC Plan:2068	2005
New	Approved Basic 04-114578BP	2 story SFR w/attached garage	2003 IRC Plan:2978	2005
New	Approved Basic 04-115238BP	Plan: 2201	Two-story SFR - 2003 IRC	2005
New	Approved Basic 04-115241BP	Plan: 2473	Two-story SFR - 2003 IRC	2005
New	Approved Basic 05-100213BP	2003 IRC	Plan: 2640 A & B Two-story	2005
New	Approved Basic 04-116177BP		Builders plan# 2575-A&B 2-Story SFR w/attached	2005
New	Approved Basic 04-116427BP	Plan: 3512 A & B	Two-story SFR with attached	2005
New	Approved Basic 05-100213BP	2003 IRC	Plan: 2640 A & B Two-story SF	2005

Accessory Dwelling Units

Index # - File Name: 1.0022 - Single Family Dwellings Data\_Snohomish County.pdf

New	Approved Basic 04-114574BP	2 story SFRw/attached garage	2003 IRC	Plan:1861	2005
New	Approved Basic 04-115238BP			Plan: 2201 Two-story SFR - 2003 IRC	2005
New	Approved Basic 04-118514BP	2 story SFR w/attached garage	2003 IRC	Plan:2068	2005
New	Approved Basic 04-117671BP	2 story SFR w/attached garage	2003 IRC	Plan:2153	2005
New	Approved Basic 04-115238BP			Plan: 2201 Two-story SFR - 2003 IRC	2005
New	Approved Basic 04-115241BP			Plan: 2473 Two-story SFR - 2003 IRC	2005
New	Approved Basic 04-118514BP	2 story SFR w/attached garage	2003 IRC	Plan:2068	2005
New	Approved Basic 04-115238BP			Plan: 2201 Two-story SFR - 2003 IRC	2005
New	Approved Basic 04-114578BP	2 story SFR w/attached garage	2003 IRC	Plan:2978	2005
New	Approved Basic 04-115241BP			Plan: 2473 Two-story SFR - 2003 IRC	2005
New	Approved Basic 04-117671BP	2 story SFR w/attached garage	2003 IRC	Plan:2153	2005
New	Approved Basic 04-114574BP	2 story SFRw/attached garage	2003 IRC	Plan:1861	2005
New	Approved Basic 04-118514BP	2 story SFR w/attached garage	2003 IRC	Plan:2068	2005
New	Approved Basic 04-115241BP			Plan: 2473 Two-story SFR - 2003 IRC	2005
New	Approved Basic 04-115238BP			Plan: 2201 Two-story SFR - 2003 IRC	2005
New	Approved Basic 04-115241BP			Plan: 2473 Two-story SFR - 2003 IRC	2005
New	Approved Basic 04-114578BP	2 story SFR w/attached garage	2003 IRC	Plan:2978	2005
New	Approved Basic 04-115241BP			Plan: 2473 Two-story SFR - 2003 IRC	2005
New	Approved Basic 04-115241BP			Plan: 2473 Two-story SFR - 2003 IRC	2005
New	2 story SFR w/attached garage	2003 IRC		Plan:4008-C	2005
New	Two-story SFR with attached garage - 2003 IRC				2005
New	Two-story SFR with attached garage - 2003 IRC			Plan 4010D-B-X	2005
New	Two-story SFR with attached garage - 2003 IRC			Plan: 3010-A	2005
New	Two-story SFR with attached garage - 2003 IRC			Plan 5022F-B	2005
New	2 story SFR w/attached garage	2003 IRC		5022F-C	2005
New	2 story SFR w/attached garage	2003 IRC		Plan:4008-A-G	2005
New	2 Story SFR w/attached garage	2003 IRC		Plan:4010DB-B	2005
New	2 story SFR w/attached garage	2003 IRC		Plan:4008-A-D	2005
New	2 story SFR w/attached garage	2003 IRC		Plan 4111-B-RD	2005
New	2 story SFR w/attached garage	2003 IRC		Plan:3010-B	2005
New	Two-story SFR with attached garage - 2003 IRC				2005
New	Two-story SFR with attached garage - 2003 IRC				2005
New	2 story SFR w/attached garage	2003 IRC		Plan:3012-B	2005
New	2 story SFR w/attached garage	2003 IRC		Plan:4010D-B-X	2005
New	2 story SFR w/attached garage	2003 IRC		Plan:3111B-A-G	2005
New	2 story SFR w/attached garage	2003 IRC		Plan:5022F-C	2005
New	2 story SFR w/attached garage	2003 IRC		Plan:4002-B-L	2005
New	2 story SFR w/attached garage	2003 IRC		Plan:5022FB-B	2005
New	2 story SFR w/attached garage	2003 IRC		Plan:4008-C-G	2005
New	3634 sq ft Rambler with daylight basement & attached garage				2005
New	Approved Basic 04-115763BP			Plan: 2880 Two-story SFR - 2003 IRC	2005
New	Approved Basic 04-116582BP	2 story SFR w/attached garage	2003 IRC	Plan:2274	2005
New	2-Story SFR w/attached garage.				2005
New	Approved Basic #05-100005BP	Two Story SFR with Attached Garage	2003 IRC		2005
New	Approved Basic 04-116582BP	2 story SFR w/attached garage	2003 IRC	Plan:2274	2005
New	2 story SFR w/attached garage	2003 IRC		Plan:Sierra B 2-car	2005
New	2 story SFR w/attached garage	2003 IRC		Plan:Olympic A-2 car	2005

Accessory Dwelling Units

Index # - File Name: 1.0022 - Single Family Dwellings Data\_Snohomish County.pdf

New	2 story SFR w/attached garage	2003 IRC	Plan:Meridian 2 Car	2005
New	2-story SFR w/garage	2003 IRC	Plan:Preston A	2005
New	2 story SFR w/attached garage	2003 IRC	Plan:Roslyn B	2005
New	2 story SFR w/attached garage			2005
New	2 story SFR w/attached garage	2003 IRC	Plan: Richmond B	2005
New	2 story SFR w/attached garage	2003 IRC	Plan:Roslyn B-3 Car	2005
New	2 story SFR w/attached garage	2003 IRC	Plan:Meridian-2 car	2005
New	2 story SFR w/attached garage	2003 IRC	Plan:Meridian A End	2005
New	2 - story SFR w/attached garage			2005
New	Two story SFR with attached Garage			2005
New	Two-story sfr with garage.			2005
New	2-Story SFR w/attached garage.			2005
New	Two-story sfr with attached garage			2005
New	2-story w/garage	2003 IRC	Plan:Preston A	2005
New	2-story SFR w/garage			2005
New	2-story SFR w/garage			2005
New	Approved basic 05-122313BP	2003 IRC	Plan# M2625A-3F-5 2 story sfr w/attached ga	2005
New	Approved Basic 04-120560BP		Plan: M2415A3F-4 Two-story SFR with att:	2005
New	Approved Basic 04-120841BP		Plan: M2650A350 Two-story SFR with attac	2005
New	Approved Basic 04-120834BP		Plan: M2605A350 Two-story SFR with a	2005
New	Approved Basic 04 -111448 BP		Builder s plan: 2-3000-3 Two-story	2005
New	2-story sfr w/attached garage			2005
New	Two-story sfr with attached garage			2005
New	Two-story SFR		Builder s Plan: Preston A	2005
New	Two story SFR with attached Garage			2005
New	Two-story SFR - 2003 IRC		Builders Plan: :	2005
New	Approved Basic 05-116604 BP	2003 IRC	Plan: 2089	2005
New	Approved Basic 04-120841BP		Plan: M2650A350 Two-story SFR with attac	2005
New	Approved basic 05-122314 BP	2003 IRC	Plan#M2780B3F-0 2-story sfr w/attached	2005
New	Two-story SFR - 2003 IRC		Builders Plan: :	2005
New	2 story single family residence			2005
New	Two Story SFR with Attached Garage	2003 IRC		2005
New	Two-story SFR with 1030sf finished daylight basement and attached garage - 2003 IRC			2005
New	2-story sfr with 3-car garage			2005
New	Two-story SFR - split level entry - 1997UBC. Ref 04-115312 GR			2005
New	One-story SFR w/finished basement - 2003 IRC			2005
New	2 story sfr w/attached garage			2005
New	Two-story SFR with 266sf unfinished basement and attached garage 2003 IRC			2005
New	Three story SFR			2005
New	2-story SFR w/attached garage			2005
New	2-story SFR w/attavhed garage			2005
New	Approved Basic #05-101837 BP	2003 IRC	Plan:1979	2005
New	Approved Basic 04-116274BP	2003 IRC	Plan:The HillcrestT	2005
New	Approved Basic 04-120030BP		Plan :The Chandler 1 Story SFR w/semifinished basement	2005
New	Approved Basic 04-120030BP	2003 IRC	Plan :The Chandler 1 Story SFR w/semifinist	2005
New	Approved Basic 04-116274BP	2003 IRC	Plan:The HillcrestT	2005
New	1392 sf rambler FHA - see comment .			2005

Accessory Dwelling Units

Index # - File Name: 1.0022 - Single Family Dwellings Data\_Snohomish County.pdf

New	Approved Basic #02-109809 BP		Plan: Jessica II Rambler Style SFR - 1997 UBC		2005
New	Two-story SFR with attached garage - 2003 IRC				2005
New	Approved Basic 04-120024	2003 IRC	Plan Northridge rambler style w/3 car g		2005
New	Approved Basic 04-116275BP	2003 IRC	Plan:Eagle Crest		2005
New	rambler style SFR w/garage				2005
New	Approved BASIC 04-113472-BP		Bldr s. Plan 2197 Rambler Style SFR - 2003-IR		2005
New	Two story SFR with attached garage				2005
New	Approved Basic 04-120030BP	2003 IRC	Plan :The Chandler 1 Story SFR w/semifinished		2005
New	Approved Basic 04-116274BP	2003 IRC	Plan:The HillcrestT		2005
New	Approved Basic 04-120026 BP		rambler style w/3 car garage	2003 IRC	Plan: The Ric
New	Approved Basic 05-126242BP		Plan: Basic 4	2003 IRC	Rambler-styl
New	Approved Basic 05-125233BP	2 story SFR w/attch garage	2003 IRC	Plan: Accolade #3	2005
New	Approved Basic 05-123477 BP	2003 IRC	Plan: Bryant	2 story SFR w/attached garage	2005
New	Rambler w/attached garage				2005
New	Rambler w/attached garage				2005
New	Rambler w/attached garage				2005
New	Rambler with Attached Garage				2005
New	1146 sq ft Ramble with 558 sq ft basement & attached Garage				2005
New	Approved Basic 05-118952 BP	2003IRC	Plan # 1642 split	2 - story SFR w/attache	2005
New	Approved basic 05-118952 BP	2003IRC	Plan # 1642 split	2 - story SFR w/attache	2005
New	Approved basic 05-118952 BP	2003IRC	Plan # 1642 split	2 - story SFR w/attache	2005
New	Approved basic 05-118952 BP	2003IRC	Plan # 1642 split	2 - story SFR w/attache	2005
New	Approved basic 05-118952 BP	2003IRC	Plan # 1642 split	2 - story SFR w/attache	2005
New	Approved basic 05-118952 BP	2003IRC	Plan # 1642 split	2 - story SFR w/attache	2005
New	Approved basic 05-118952 BP	2003IRC	Plan # 1642 split	2 - story SFR w/attache	2005
New	Approved Basic 05-116786BP	Two story SFR with Attached Garage	2003 IRC	Plan 159	2005
New	Approved Basic #05-116784BP	2003 IRC		Plan:1510	2005
New	Approved Basic 05-116786BP	Two story SFR with Attached Garage	2003 IRC	Plan 1590	2005
New	Approved Basic #05-116784BP	2003 IRC		Plan:1510	2005
New	Approved Basic 05-116786BP	Two story SFR with Attached Garage	2003 IRC	Plan 1590	2005
New	Approved Basic #05-116784BP	2003 IRC		Plan:1510	2005
New	2 story SFR w/attached garage	2003 IRC	Plan:3006 C-RG		2005
New	2-story sfr finished basment w/attached garage				2005
New	Two-story sfr with garage				2005
New	2 story sfr w/attached garage				2005
New	Approved Basic 05-119451BP	2003 IRC	2 story SFR w/attached garage	Plan:20	2005
New	Approved Basic 05-119450BP	2003 IRC	2 story SFR w/attached garage	Plan:2370	2005
New	Approved Basic 05-119456BP	2003 IRC	2 story SFR w/attached garage	Plan: 2217	2005
New	Approved Basic 05-119452BP	2003 IRC	2 story SFR w/attached garage	Plan:249	2005
New	Approved Basic 05-119451BP	2003 IRC	2 story SFR w/attached garage	Plan:20	2005
New	Approved Basic 05-119452BP	2003 IRC	2 story SFR w/attached garage	Plan:249	2005
New	Approved Basic 05-119452BP	2003 IRC	2 story SFR w/attached garage	Plan:249	2005
New	Approved Basic 05-119450BP	2003 IRC	2 story SFR w/attached garage	Plan:2370	2005
New	Approved Basic 05-119450BP	2003 IRC	2 story SFR w/attached garage	Plan:2370	2005
New	Approved Basic 05-119456BP	2003 IRC	2 story SFR w/attached garage	Plan: 2217	2005
New	Approved Basic 05-119452BP	2003 IRC	2 story SFR w/attached garage	Plan:249	2005



Accessory Dwelling Units

Index # - File Name: 1.0022 - Single Family Dwellings Data\_Snohomish County.pdf

New	Approved Basic 05-119451BP	2003 IRC	2 story SFR w/attached garage	Plan:20	2005
New	Approved Basic 05-119451BP	2003 IRC	2 story SFR w/attached garage	Plan:20	2005
New	Approved Basic 05-119451BP	2003 IRC	2 story SFR w/attached garage	Plan:20	2005
New	Approved Basic 05-119451BP	2003 IRC	2 story SFR w/attached garage	Plan:20	2005
New	Approved Basic 05-119451BP	2003 IRC	2 story SFR w/attached garage	Plan:20	2005
New	Approved Basic 05-119451BP	2003 IRC	2 story SFR w/attached garage	Plan:20	2005
New	Approved Basic 05-119450BP	2003 IRC	2 story SFR w/attached garage	Plan:2370	2005
New	Approved Basic 05-119450BP	2003 IRC	2 story SFR w/attached garage	Plan:2370	2005
New	Approved Basic 05-119452BP	2003 IRC	2 story SFR w/attached garage	Plan:249	2005
New	Approved Basic 05-119451BP	2003 IRC	2 story SFR w/attached garage	Plan:20	2005
New	Approved Basic 05-119451BP	2003 IRC	2 story SFR w/attached garage	Plan:20	2005
New	Approved Basic 05-119450BP	2003 IRC	2 story SFR w/attached garage	Plan:2370	2005
New	Approved Basic 05-119452BP	2003 IRC	2 story SFR w/attached garage	Plan:249	2005
New	Approved Basic #04-118889 BP		2-story w/garage	2003 IRC	2005
New	Approved basic 05-120842 BP	2003 IRC	Plan #: 1885 2-story sfr w/attached garage		2005
New	Approved Basic #04-118889 BP		2-story w/garage	2003 IRC	2005
New	Approved basic 05-120842 BP	2003 IRC	Plan #: 1885 2-story sfr w/attached garage		2005
New	Approved Basic #04-118889 BP		2-story w/garage	2003 IRC	2005
New	Approved basic 05-120842 BP	2003 IRC	Plan #: 1885 2-story sfr w/attached garage		2005
New	Approved Basic #04-118889 BP		2-story w/garage	2003 IRC	2005
New	2-Story SFR w/attached garage				2005
New	Two-story SFR with attached garage -	2003 IRC			2005
New	Rambler w/ unfin. basement, & 2 car garage				2005
New	Approved Basic 05-100936-BP	2003 IRC		Plan:1703-Bonus	2005
New	Approved Basic 05-100936-BP	2003 IRC		Plan:1703-Bonus	2005
New	Two-story SFR with attached garage -	2003 IRC			2005
New	Two-story SFR with attached garage -	2003 IRC			2005
New	2 story SFR w/attached garage				2005
New	Plan #: R 2930B3S-0		2-story SFR w/attached garage		2005
New	2-story sfr w/attached garage				2005
New	2 story sfr w/attached garage				2005
New	Plan# M3220A3R-0		2 story SFR w/attached garage		2005
New	Two story SFR with attached Garage				2005
New	Two story SFR with attached Garage				2005
New	Two-story sfr with attached garage				2005
New	Two-story SFR with unfinished basement and attached garage -	2003 IRC			2005
New	2 story SFR w/ 3 car garage				2005
New	Approved #05-128143 BP	2003 IRC		Plan: 1728 1	2005
New	Approved #05-128143 BP	2003 IRC		Plan: 1728 1	2005
New	Approved basic 05-119630 BP	2003 IRC	Plan# 2195 SFR Mid-entry w/attached g;		2005
New	Approved Basic #05-117513BP	2003 IRC	2 story SFR w/attachedGarage	Plan:2780IRC	2005
New	Approved basic 05-119630 BP	2003 IRC	Plan# 2195 SFR Mid-entry w/attached gara		2005
New	Approved basic 05-119630 BP	2003 IRC	Plan# 2195 SFR Mid-entry w/attached g;		2005
New	Approved Basic #05-117513BP	2003 IRC	2 story SFR w/attachedGarage	Plan:2780IR	2005
New	One-story SFR w/finished basement		Builders Plan: 2407		2005
New	Approved Basic 04-120167BP	2 story SFR w/attached garage	2003 IRC	Plan:2597	2005
New	Approved Basic 05-117030BP	2003 IRC	Plan:2294-3 car G		2005

Accessory Dwelling Units

Index # - File Name: 1.0022 - Single Family Dwellings Data\_Snohomish County.pdf

New	Approved Basic 05-116799BP		2003 IRC	Plan:2597 3 Car	2005
New	Approved Basic 05-117030BP		2003 IRC	Plan:2294-3 car G	2005
New	Approved Basic 05-116799BP		2003 IRC	Plan:2597 3 Car	2005
New	Approved Basic 05-116800BP		2003 IRC	Plan:1932- 3 Car	2005
New	2-Story SFR w/attached garage.				2005
New	Two-story sfr w/attached garage				2005
New	Two story SFR with attached Garage				2005
New	2 story SFR w/attached garage				2005
New	Approved Basic 05-116799BP		2003 IRC	Plan:2597 3 Car	2005
New	Approved Basic 05-117030BP		2003 IRC	Plan:2294-3 car G	2005
New	Approved Basic 05-119780BP	2003 IRC	2 story SFR w/attached garage	Plan:2463	2005
New	Approved Basic 05-116800BP		2003 IRC	Plan:1932- 3 Car	2005
New	Approved Basic 05-119780BP	2003 IRC	2 story SFR w/attached garage	Plan:2463	2005
New	Approved Basic 04-111161BP	2003 IRC	Plan: 1932	Two-story SFR w/attached ga	2005
New	Approved Basic 04-115367BP	2 story SFR w/attached garage	2003 IRC	Plan:1932 ALT	2005
New	Approved Basic 04-116621BP	2 Story SFR w/attached garage	2003 IRC	Plan:1909	2005
New	Approved Basic 04-120167BP	2 story SFR w/attached garage	2003 IRC	Plan:2597	2005
New	Approved Basic 04-111161BP	2003 IRC	Plan: 1932	Two-story SFR w/attached ga	2005
New	Approved Basic 04-120167BP	2 story SFR w/attached garage	2003 IRC	Plan:2597	2005
New	Approved Basic 04-111161BP	2003 IRC	Plan: 1932	Two-story SFR w/attached ga	2005
New	Approved Basic 05-118338BP	2003 IRC	Plan:1909BSM		2005
New	Approved Basic 05-118338BP	2003 IRC	Plan:1909BSM		2005
New	Approved Basic 05-118338BP	2003 IRC	Plan:1909BSM		2005
New	Approved Basic 05-118338BP	2003 IRC	Plan:1909BSM		2005
New	Approved Basic 04-118845BP	2 story SFR w/attached garage	2003 IRC	Plan:2294	2005
New	Approved Basic 04-111161BP	2003 IRC	Plan: 1932	Two-story SFR w/attached ga	2005
New	Approved Basic 04-120167BP	2 story SFR w/attached garage	2003 IRC	Plan:2597	2005
New	Approved Basic 04-118845BP	2 story SFR w/attached garage	2003 IRC	Plan:2294	2005
New	Approved Basic 04-118845BP	2 story SFR w/attached garage	2003 IRC	Plan:2294	2005
New	Approved Basic 05-118338BP	2003 IRC	Plan:1909BSM		2005
New	Approved Basic 05-118338BP	2003 IRC	Plan:1909BSM		2005
New	Approved Basic 04-118845BP	2 story SFR w/attached garage	2003 IRC	Plan:2294	2005
New	Approved Basic 04-120167BP	2 story SFR w/attached garage	2003 IRC	Plan:2597	2005
New	Approved Basic 04-118845BP	2 story SFR w/attached garage	2003 IRC	Plan:2294	2005
New	Approved Basic 04-120167BP	2 story SFR w/attached garage	2003 IRC	Plan:2597	2005
New	Approved Basic 05-118338BP	2003 IRC	Plan:1909BSM		2005
New	Approved Basic 05-118338BP	2003 IRC	Plan:1909BSM		2005
New	Approved Basic 05-118338BP	2003 IRC	Plan:1909BSM		2005
New	Approved Basic 05-118338BP	2003 IRC	Plan:1909BSM		2005
New	2005 27 X 68 Double Wide MH				2005
New	2-story SFR w/garage				2005
New	Approved Basic 04-120167BP	2 story SFR w/attached garage	2003 IRC	Plan:2597	2005
New	Approved Basic 05-118335BP	2003 IRC	Plan:1932 BSM		2005
New	Approved Basic 05-118335BP	2003 IRC	Plan:1932 BSM		2005
New	2 story SFR w/finished basement	2003 IRC	Plan:2597		2005
New	Approved Basic 05-118335BP	2003 IRC	Plan:1932 BSM		2005
New	2 story SFR w/finished basement & attached garage	2003 IRC			2005

Accessory Dwelling Units

Index # - File Name: 1.0022 - Single Family Dwellings Data\_Snohomish County.pdf

New	Two Story SFR with 180 SF Finished Basement and Attached Garage					2005
New	Approved Basic 05-116799BP		2003 IRC		Plan:2597 3 Car	2005
New	Approved Basic 05-119780BP	2003 IRC	2 story SFR w/attached garage		Plan:2463	2005
New	Approved Basic 05-124146BP	2003 IRC	2 story SFR w/attached garage		Plan: 2541	2005
New	Approved Basic 05-124146BP	2003 IRC	2 story SFR w/attached garage		Plan: 2541	2005
New	Approved Basic 05-119780BP	2003 IRC	2 story SFR w/attached garage		Plan:2463	2005
New	Approved Basic 05-119780BP	2003 IRC	2 story SFR w/attached garage		Plan:2463	2005
New	Approved Basic 05-119780BP	2003 IRC	2 story SFR w/attached garage		Plan:2463	2005
New	Approved Basic 05-119780BP	2003 IRC	2 story SFR w/attached garage		Plan:2463	2005
New	Approved Basic 05-119780BP	2003 IRC	2 story SFR w/attached garage		Plan:2463	2005
New	Approved Basic 05-117030BP	2003 IRC	Plan:2294-3 car G			2005
New	Approved Basic 05-116799BP		2003 IRC		Plan:2597 3 Car	2005
New	Approved Basic 05-117030BP	2003 IRC	Plan:2294-3 car G			2005
New	Approved Basic 05-116799BP		2003 IRC		Plan:2597 3 Car	2005
New	Approved Basic 04-120167BP	2 story SFR w/attached garage	2003 IRC		Plan:2597	2005
New	Approved basic #05-120993 BP	2003 IRC	SFR w/attached garage		Plan #24	2005
New	Approved basic #05-120994 BP	2003 IRC	2 story SFR w/attached garage		Plan: 2792	2005
New	Approved basic #05-120994 BP	2003 IRC	2 story SFR w/attached garage		Plan: 2792	2005
New	Approved basic #05-120993 BP	2003 IRC	SFR w/attached garage		Plan #24	2005
New	Approved Basic # 05-123468 BP	2003 IRC	Plan: 3065	2 Story SFR w/ attached Gar		2005
New	SFR with 1235 SF Semi Finished Basement and Attached Garage					2005
New	Approved basic #05-120994 BP	2003 IRC	2 story SFR w/attached garage		Plan: 2792	2005
New	Approved basic #05-120993 BP	2003 IRC	SFR w/attached garage		Plan #24	2005
New	Approved Basic 04-116621BP	2 Story SFR w/attached garage	2003 IRC		Plan:1909	2005
New	Approved Basic 04-118845BP	2 story SFR w/attached garage	2003 IRC		Plan:2294	2005
New	Approved Basic 04-120167BP	2 story SFR w/attached garage	2003 IRC		Plan:2597	2005
New	Approved Basic 04-118845BP	2 story SFR w/attached garage	2003 IRC		Plan:2294	2005
New	Approved Basic 04-120167BP	2 story SFR w/attached garage	2003 IRC		Plan:2597	2005
New	Approved Basic 04-118845BP	2 story SFR w/attached garage	2003 IRC		Plan:2294	2005
New	Approved Basic 04-116621BP	2 Story SFR w/attached garage	2003 IRC		Plan:1909	2005
New	Approved Basic 04-120167BP	2 story SFR w/attached garage	2003 IRC		Plan:2597	2005
New	Approved Basic 04-115367BP	2 story SFR w/attached garage	2003 IRC		Plan:1932 ALT	2005
New	Approved Basic 04-116621BP	2 Story SFR w/attached garage	2003 IRC		Plan:1909	2005
New	Approved Basic 04-118845BP	2 story SFR w/attached garage	2003 IRC		Plan:2294	2005
New	Approved Basic 04-118845BP	2 story SFR w/attached garage	2003 IRC		Plan:2294	2005
New	Approved Basic 04-120167BP	2 story SFR w/attached garage	2003 IRC		Plan:2597	2005
New	Approved Basic 04-118845BP	2 story SFR w/attached garage	2003 IRC		Plan:2294	2005
New	Approved Basic 04-115367BP	2 story SFR w/attached garage	2003 IRC		Plan:1932 ALT	2005
New	Approved Basic 04-118845BP	2 story SFR w/attached garage	2003 IRC		Plan:2294	2005
New	Approved Basic 05-124386BP	2003 IRC	2 story SFR w/attached garage		Plan:2065	2005
New	Approved Basic 04-120167BP	2 story SFR w/attached garage	2003 IRC		Plan:2597	2005
New	Approved Basic 04-111161BP	2003 IRC	Plan: 1932	Two-story SFR w/attached ga		2005
New	Approved Basic 04-118845BP	2 story SFR w/attached garage	2003 IRC		Plan:2294	2005
New	2 story SFR w/attached garage	2003 IRC	Plan:2291			2005
New	Approved Basic 04-120167BP	2 story SFR w/attached garage	2003 IRC		Plan:2597	2005
New	Approved Basic 04-120167BP	2 story SFR w/attached garage	2003 IRC		Plan:2597	2005
New	Approved Basic 04-120167BP	2 story SFR w/attached garage	2003 IRC		Plan:2597	2005

Accessory Dwelling Units

Index # - File Name: 1.0022 - Single Family Dwellings Data\_Snohomish County.pdf

New	Approved Basic 04-118845BP	2 story SFR w/attached garage	2003 IRC	Plan:2294	2005
New	Approved Basic 04-120167BP	2 story SFR w/attached garage	2003 IRC	Plan:2597	2005
New	Approved Basic 04-118845BP	2 story SFR w/attached garage	2003 IRC	Plan:2294	2005
New	Approved Basic 04-111161BP	2003 IRC	Plan: 1932	Two-story SFR w/attached ga	2005
New	Approved Basic 04-118845BP	2 story SFR w/attached garage	2003 IRC	Plan:2294	2005
New	Approved Basic 04-120167BP	2 story SFR w/attached garage	2003 IRC	Plan:2597	2005
New	Approved Basic 04-118845BP	2 story SFR w/attached garage	2003 IRC	Plan:2294	2005
New	Approved Basic 04-111161BP	2003 IRC	Plan: 1932	Two-story SFR w/attached ga	2005
New	Approved Basic 04-118845BP	2 story SFR w/attached garage	2003 IRC	Plan:2294	2005
New	Approved Basic 04-120167BP	2 story SFR w/attached garage	2003 IRC	Plan:2597	2005
New	Approved basic 05-125878BP	2003 IRC	Plan# 2216	2-story sfr w/attached gara	2005
New	Approved Basic 04-111161BP	2003 IRC	Plan: 1932	Two-story SFR w/attached ga	2005
New	Approved Basic 05-116799BP		2003 IRC	Plan:2597 3 Car	2005
New	Approved Basic 05-117030BP		2003 IRC	Plan:2294-3 car G	2005
New	Approved Basic 05-116799BP		2003 IRC	Plan:2597 3 Car	2005
New	Approved Basic 05-117030BP		2003 IRC	Plan:2294-3 car G	2005
New	approved Basic 05-121196BP		2003 IRC	Plan: 1710 Two-story SF	2005
New	Approved Basic 05-121025-BP	2003 IRC	2 story SFR w/attached garage	Bldrs. Plan: 214	2005
New	Approved Basic 05-121025-BP	2003 IRC	2 story SFR w/attached garage	Bldrs. Plan: 214	2005
New	Approved Basic 05-121196BP		2003 IRC	Plan: 1710 Two-story SF	2005
New	Approved Basic 05-120823BP	2003 IRC	2 story SFR w/attached garage	Plan:1890	2005
New	Approved Basic 05-121196BP		2003 IRC	Plan: 1710 Two-story SF	2005
New	Approved Basic 05-121025-BP	2003 IRC	2 story SFR w/attached garage	Bldrs. Plan: 214	2005
New	Approved Basic 05-120713BP	2003 IRC	2 story SFR w/attached garage	Plan:2224F	2005
New	Approved Basic #05-118418 BP	2003 IRC	Plan #2452	Two story SFR w/ Attached G	2005
New	Approved Basic 05-120701 BP		2003 IRC	Plan: 2591	2005
New	Approved Basic 05-120713BP	2003 IRC	2 story SFR w/attached garage	Plan:2224F	2005
New	Approved Basic 05-120707BP	2003 IRC	2 story SFR w/attached garage	Plan:2155	2005
New	Approved Basic #05-118418 BP	2003 IRC	Plan #2452	Two story SFR w/ Attached G	2005
New	Approved Basic 05-120701 BP		2003 IRC	Plan: 2591	2005
New	Approved Basic 05-120715BP	2 story SFR w/attached garage	2003 IRC	Plan:2224S/Westo	2005
New	SFR w/attached garage	2003 IRC	Plan:1971		2005
New	SFR w/attached garage	2003 IRC	Plan:1971		2005
New	Approved Basic 05-120707BP	2003 IRC	2 story SFR w/attached garage	Plan:2155	2005
New	Two story SFR with attached Garage				2005
New	Approved Basic #05-118418 BP	2003 IRC	Plan #2452	Two story SFR w/ Attached G	2005
New	2 - story sfr w/attached garage				2005
New	2 - story sfr w/attached garage				2005
New	2 - story sfr w/attached garage				2005
New	2-story sfr w/attached garage				2005
New	2 - story sfr w/attached garage				2005
New	2 story sfr w/attached garage				2005
New	**PERMIT CLOSED ON A COPY.	Approved basic 05-121525 BP	2003 IRC	Plan# 2591	2005
New	2-story sfr w/attached garage				2005
New	Approved basic 05-121526 BP	2003 IRC	Plan#2452	2-story sfr w/attached garage	2005
New	2-story sfr w/attached garage				2005
New	Approved Basic 05-121525 BP	2003 IRC	Plan# 2591	2-story sfr w/attached garage	2005

Accessory Dwelling Units

Index # - File Name: 1.0022 - Single Family Dwellings Data\_Snohomish County.pdf

New	2 story sfr w/attached garage					2005
New	Approved basic 05-121526 BP	2003 IRC	Plan#2452	2-story sfr w/attached garage		2005
New	2 story SFR w/attached garage	2003 IRC				2005
New	Approved Basic 05-121000BP	2003 IRC	2 story SFR w/attached garage	Plan:2224		2005
New	Approved Basic 05-121008BP	2003 IRC	2 story SFR w/attached garage	Plan:2294-B		2005
New	Approved Basic 05-121007BP	2003 IRC	2 story SFR w/attached garage	Plan:2294-A		2005
New	Approved Basic 05-121010BP	2003 IRC	2 story SFR w/attached garage	Plan:2452		2005
New	Approved Basic 05-121010BP	2003 IRC	2 story SFR w/attached garage	Plan:2452		2005
New	Approved Basic 05-121010BP	2003 IRC	2 story SFR w/attached garage	Plan:2452		2005
New	Approved Basic 05-121007BP	2003 IRC	2 story SFR w/attached garage	Plan:2294-A		2005
New	Approved Basic 05-121003BP	2003 IRC	2 story SFR w/attached garage	Plan:259		2005
New	Approved Basic 05-121008BP	2003 IRC	2 story SFR w/attached garage	Plan:2294-I		2005
New	2 story SFR w/attached garage	2003 IRC				2005
New	2 story SFR w/attached garage	2003 IRC				2005
New	2 story SFR w/attached garage	2003 IRC				2005
New	2 story SFR w/attached garage	2003 IRC				2005
New	2 story SFR w/attached garage	2003 IRC				2005
New	2 story SFR w/attached garage	2003 IRC				2005
New	2 story SFR w/attached garage	2003 IRC				2005
New	2 story SFR w/attached garage	2003 IRC				2005
New	Two-story SFR with attached garage					2005
New	Approved basic 05-120411 BP	2003 IRC	Plan# 2300	2-story sfr w/attached garage		2005
New	Approved basic 05-120412 BP	2003 IRC	Plan# 2600	2-story sfr w/attached garage		2005
New	Approved basic 05-120412 BP	2003 IRC	Plan# 2600	2-story sfr w/attached garage		2005
New	Approved basic 05-120411 BP	2003 IRC	Plan# 2300	2-story sfr w/attached garage		2005
New	Approved basic 05-120412 BP	2003 IRC	Plan# 2600	2-story sfr w/attached garage		2005
New	Approved basic 05-120412 BP	2003 IRC	Plan# 2600	2-story sfr w/attached garage		2005
New	Approved Basic 05-123237 BP	2003 IRC	Plan# 2211	2-story sfr w/attached garage		2005
New	Approved Basic 05-123237 BP	2003 IRC	Plan# 2211	2-story sfr w/attached garage		2005
New	Approved Basic 05-123237 BP	2003 IRC	Plan# 2211	2-story sfr w/attached garage		2005
New	Approved Basic 05-123237 BP	2003 IRC	Plan# 2211	2-story sfr w/attached garage		2005
New	Approved Basic 05-123237 BP	2003 IRC	Plan# 2211	2-story sfr w/attached garage		2005
New	Approved basic 05-120412 BP	2003 IRC	Plan# 2600	2-story sfr w/attached garage		2005
New	Approved Basic 05-120823 BP		2003 IRC	Plan: 1890		2005
New	Approved Basic 05-121196BP		2003 IRC	Plan: 1710	Two-story SF	2005
New	Approved Basic 05-121025-BP	2003 IRC	2 story SFR w/attached garage	Bldrs. Plan: 214		2005
New	Approved Basic 05-121025-BP	2003 IRC	2 story SFR w/attached garage	Bldrs. Plan: 214		2005
New	Approved Basic 05-121025-BP	2003 IRC	2 story SFR w/attached garage	Bldrs. Plan: 214		2005
New	Approved Basic 05-121196BP		2003 IRC	Plan: 1710	Two-story SF	2005
New	Approved Basic 05-121025-BP	2003 IRC	2 story SFR w/attached garage	Bldrs. Plan: 214		2005
New	Two story SFR with attached Garage					2005
New	Two-story sfr with garage					2005
New	Two-story sfr with garage					2005
New	Approved Basic 05-120707BP	2003 IRC	2 story SFR w/attached garage	Plan:2155		2005
New	Approved basic 05-120412 BP	2003 IRC	Plan# 2600	2-story sfr w/attached garage		2005
New	Approved Basic 05-120702BP	2003 IRC	2 story SFR w/attached garage	Plan:2728-B		2005
New	Approved Basic 05-127952BP	2003 IRC	2 story SFR w/attached garage	Plan 2615FC		2005

Accessory Dwelling Units

Index # - File Name: 1.0022 - Single Family Dwellings Data\_Snohomish County.pdf

New	Approved	Basic 05-127952BP	2003 IRC	2 story SFR w/attached garage	Plan 2615FC	2005
New	Approved	basic 05-122464 BP	2003 IRC	Plan# 2211 FC	2-story sfr w/attached garage	2005
New	Approved	basic 05-122463 BP	2003 IRC	Plan# 2206 FC	2-story sfr w/attached garage	2005
New	Approved	basic 05-122464 BP	2003 IRC	Plan# 2211 FC	2-story sfr w/attached garage	2005
New	Approved	basic 05-122463 BP	2003 IRC	Plan# 2206 FC	2-story sfr w/attached garage	2005
New	Approved	basic 05-122464 BP	2003 IRC	Plan# 2211 FC	2-story sfr w/attached garage	2005
New	Approved	basic 05-122463 BP	2003 IRC	Plan# 2206 FC	2-story sfr w/attached garage	2005
New	Approved	basic 05-122464 BP	2003 IRC	Plan# 2211 FC	2-story sfr w/attached garage	2005
New	Approved	Basic 05-120704BP	2003 IRC	2 story SFR w/attached garage	Plan:2877-A	2005
New	Approved	Basic 05-120703BP	2003 IRC	2 story SFR w/attached garage	Plan:2755-A	2005
New	Approved	basic 05-124684 BP	2003 IRC	Plan: 2283 FC	2-story sfr w/attached garage	2005
New	Approved	Basic 05-120703BP	2003 IRC	2 story SFR w/attached garage	Plan:2755-A	2005
New	Approved	Basic 05-120704BP	2003 IRC	2 story SFR w/attached garage	Plan:2877-A	2005
New	Approved	Basic 05-120700BP	2003 IRC	2 story SFR w/attached garage	Plan:2828-B	2005
New	Approved	Basic 05-120703BP	2003 IRC	2 story SFR w/attached garage	Plan:2755-A	2005
New	Approved	Basic 05-120704BP	2003 IRC	2 story SFR w/attached garage	Plan:2877-A	2005
New	Approved	Basic 05-120702BP	2003 IRC	2 story SFR w/attached garage	Plan:2728-B	2005
New	Approved	Basic 05-120700BP	2003 IRC	2 story SFR w/attached garage	Plan:2828-B	2005
New	Approved	Basic 05-120703BP	2003 IRC	2 story SFR w/attached garage	Plan:2755-A	2005
New	Approved	Basic 05-120702BP	2003 IRC	2 story SFR w/attached garage	Plan:2728-B	2005
New	Approved	Basic 05-120704BP	2003 IRC	2 story SFR w/attached garage	Plan:2877-A	2005
New	approved	basic 05-124684 BP	2003 IRC	Plan# 2283 FC	2-story sfr w/attached	2005
New	Approved	basic 05-120411 BP	2003 IRC	Plan# 2300	2-story sfr w/attached garage	2005
New	Approved	basic 05-120412 BP	2003 IRC	Plan# 2600	2-story sfr w/attached garage	2005
New	Approved	basic 05-120411 BP	2003 IRC	Plan# 2300	2-story sfr w/attached garage	2005
New	Approved	basic 05-120412 BP	2003 IRC	Plan# 2600	2-story sfr w/attached garage	2005
New	Approved	basic 05-120411 BP	2003 IRC	Plan# 2300	2-story sfr w/attached garage	2005
New	Approved	basic 05-120412 BP	2003 IRC	Plan# 2600	2-story sfr w/attached garage	2005
New	Approved	basic 05-120411 BP	2003 IRC	Plan# 2300	2-story sfr w/attached garage	2005
New	Approved	basic 05-120412 BP	2003 IRC	Plan# 2600	2-story sfr w/attached garage	2005
New	Approved	basic 05-120411 BP	2003 IRC	Plan# 2300	2-story sfr w/attached garage	2005
New	Approved	basic 05-120412 BP	2003 IRC	Plan# 2600	2-story sfr w/attached garage	2005
New	Approved	basic 05-120412 BP	2003 IRC	Plan# 2600	2-story sfr w/attached garage	2005
New	Approved	basic 05-125156 BP	2003 IRC	Plan# 2700	2-story sfr w/attached	2005
New	Approved	Basic 05-120704BP	2003 IRC	2 story SFR w/attached garage	Plan:2877-A	2005
New	Approved	basic 05-124686 BP	2003 IRC	Plan 2236 FC	2-story sfr w/attached gara	2005
New	Approved	basic 05-124686 BP	2003 IRC	Plan 2236 FC	2-story sfr w/attached garage	2005
New	Approved	basic 05-122464 BP	2003 IRC	Plan# 2211 FC	2-story sfr w/attached garage	2005
New	2-story sfr w/attached garage					2005
New	Approved	Basic 05-118698BP	2005 IRC	2 story SFR w/attached garage	Plan:BA	2005
New	Approved	Basic 04-118812BP	SFR w/attached garage	2003 IRC	Plan:F	2005
New	Approved	Basic 05-122739BP	2003 IRC	3 story SFR w/attached garage	Plan:Preston	2005
New	Approved	Basic 05-122739BP	2003 IRC	3 story SFR w/attached garage	Plan:Preston	2005
New	Approved	Basic 05-122739BP	2003 IRC	3 story SFR w/attached garage	Plan:Preston	2005
New	Approved	Basic 05-122739BP	2003 IRC	3 story SFR w/attached garage	Plan:Preston	2005
New	Approved	Basic 05-118707BP	2003 IRC	2 story SFR w/attached garage	Plan:KC	2005
New	Approved	Basic 05-122739BP	2003 IRC	3 story SFR w/attached garage	Plan:Preston	2005



Accessory Dwelling Units

Index # - File Name: 1.0022 - Single Family Dwellings Data\_Snohomish County.pdf

New	Approved Basic 05-119590BP	2003 IRC	2 story SFR w/attached garage	Plan:3023A	2005
New	Approved Basic 05-119591BP	2003 IRC	2 story SFR w/attached garage	Plan:302	2005
New	Approved Basic 05-119825BP	2005 IRC	2 story SFR w/attached garage	Plan:3026	2005
New	Approved Basic 05-119584BP	2003 IRC	2 story SFR w/attached garage	Plan:3022A	2005
New	Approved Basic 05-119588BP	2003 IRC	2 story SFR w/attached garage	Plan:302	2005
New	Approved Basic 05-119972BP	2003 IRC	2 story SFR w/attached garage	Plan:3111E	2005
New	Approved Basic 05-119592BP	2003 IRC	2 story SFR w/attached garage	Plan:3024B	2005
New	Approved Basic 05-119586BP	2003 IRC	2 story SFR w/attached garage	Plan:3022E	2005
New	Approved Basic 05-119829BP	2003 IRC	2 story SFR w/attached garage	Plan:3012A	2005
New	Approved Basic 05-119824BP	2003 IRC	2 story SFR w/attached garage	Plan:3026A	2005
New	Approved Basis 05-120301BP	2003 IRC	2 story SFR w/attached garage	Plan:3111B-	2005
New	Approved Basic 05-119588BP	2003 IRC	2 story SFR w/attached garage	Plan:302	2005
New	Approved Basic 05-119591BP	2003 IRC	2 story SFR w/attached garage	Plan:302	2005
New	Approved Basic 05-119584BP	2003 IRC	2 story SFR w/attached garage	Plan:3022A	2005
New	Approved Basic 05-119586BP	2003 IRC	2 story SFR w/attached garage	Plan:3022E	2005
New	Approved Basic 05-119592BP	2003 IRC	2 story SFR w/attached garage	Plan:3024B	2005
New	Approved Basic 05-119588BP	2003 IRC	2 story SFR w/attached garage	Plan:302	2005
New	Approved Basic 05-119584BP	2003 IRC	2 story SFR w/attached garage	Plan:3022A	2005
New	Approved Basic 05-119591BP	2003 IRC	2 story SFR w/attached garage	Plan:302	2005
New	Approved Basic 05-119825BP	2005 IRC	2 story SFR w/attached garage	Plan:3026	2005
New	Approved Basic 05-119826BP	2003 IRC	2 story SFR w/attached garage	Plan:3111	2005
New	Approved Basic 05-119829BP	2003 IRC	2 story SFR w/attached garage	Plan:3012A	2005
New	Approved Basic 05-119588BP	2003 IRC	2 story SFR w/attached garage	Plan:302	2005
New	Approved Basic 05-119824BP	2005 IRC	2 story SFR w/attached garage	Plan:3026A	2005
New	Approved Basic 05-119829BP	2003 IRC	2 story SFR w/attached garage	Plan:3012A	2005
New	Approved Basic 05-11997 3BP	2003 IRC	2 story SFR w/attached garage	Plan:3111B-	2005
New	Approved Basic 05-119584BP	2003 IRC	2 story SFR w/attached garage	Plan:3022A	2005
New	Approved Basic 05-119592BP	2003 IRC	2 story SFR w/attached garage	Plan:3024B	2005
New	Approved Basic 05-119829BP	2003 IRC	2 story SFR w/attached garage	Plan:3012A	2005
New	Approved Basic 05-119972BP	2003 IRC	2 story SFR w/attached garage	Plan:3111E	2005
New	Approved Basic 05-119588BP	2003 IRC	2 story SFR w/attached garage	Plan:302	2005
New	Approved Basic 05-119591BP	2003 IRC	2 story SFR w/attached garage	Plan:302	2005
New	Approved Basic 05-119827BP	2003 IRC	2 story SFR w/attached garage	Plan:3111	2005
New	Approved Basic 05-119586BP	2003 IRC	2 story SFR w/attached garage	Plan:3022E	2005
New	Approved Basic 05-119829BP	2003 IRC	2 story SFR w/attached garage	Plan:3012A	2005
New	Approved Basic 05-119584BP	2003 IRC	2 story SFR w/attached garage	Plan:3022A	2005
New	Approved Basic 05-119591BP	2003 IRC	2 story SFR w/attached garage	Plan:302	2005
New	Approved Basic 05-119824BP	2003 IRC	2 story SFR w/attached garage	Plan:3026A	2005
New	Approved Basis 05-120301BP	2003 IRC	2 story SFR w/attached garage	Plan:3111B-	2005
New	Approved Basic 05-119828BP	2003 IRC	2 story SFR w/attached garage	Plan:301	2005
New	Approved Basic 05-119588BP	2003 IRC	2 story SFR w/attached garage	Plan:302	2005
New	Approved Basic 05-119584BP	2003 IRC	2 story SFR w/attached garage	Plan:3022A	2005
New	Approved Basic 05-119825BP	2005 IRC	2 story SFR w/attached garage	Plan:3026	2005
New	Approved Basic 05-119591BP	2003 IRC	2 story SFR w/attached garage	Plan:302	2005
New	Approved Basic 05-119588BP	2003 IRC	2 story SFR w/attached garage	Plan:302	2005
New	Approved Basic 05-119592BP	2003 IRC	2 story SFR w/attached garage	Plan:3024B	2005
New	Approved Basic 05-119590BP	2003 IRC	2 story SFR w/attached garage	Plan:3023A	2005



Accessory Dwelling Units

Index # - File Name: 1.0022 - Single Family Dwellings Data\_Snohomish County.pdf

New	Approved Basic 05-119824BP	2003 IRC	2 story SFR w/attached garage	Plan:3026A	2005
New	Approved Basic 05-127302BP	2003 IRC	2 story SFR w/attached garage	Plan:4060	2005
New	Two Story SFR with Finished Basement and Attached Garage				2005
New	Two story SFR & finished Basement with detached Garage				2005
New	Two Story SFR with Finished Basement and Attached Garage				2005
New	Two story SFR with Attached Garage				2005
New	Two Story SFR with Attached Garage				2005
New	Two-story SFR				Buildes Plan: M3445A
New	Approved Basic 04-120237BP		Plan: 3510 Two-story SFR with attached 3-car		2005
New	Approved Basic 05-127302BP	2003 IRC	2 story SFR w/attached garage	Plan:4060	2005
New	Approved Basic 04-117597BP	2003 IRC	2 story SFR w/attached garage	2003 IRC Plan:3575	2005
New	Two-story SFR with finished basement				Builders Plan; M328
New	Approved Basic 04-117597BP	2003 IRC	2 story SFR w/attached garage	2003 IRC Plan:3575	2005
New	Approved Basic 05-119566-BP	2003 IRC	2 story Duplex w/attached garages		2005
New	Approve Basic 05-119566-BP	2003 IRC	2 story Duplex w/attached garages		2005
New	1896 sq ft Rambler with 616 sq ft finished & 1,264 sq ft Unfinished Basement				2005
New	Two-story sfr with garage				2005
New	2-story sfr w/attached garage				2005
New	2 story sfr w/attached garage				2005
New	Approved basic 05-121154 BP	2003 IRC	Plan# 2500 Rambler w/attached garage		2005
New	Approved basic 05-120420 BP	2003 IRC	Plan# 2760 2-story sfr w/attached garage		2005
New	Approved basic 05-120421 BP	2003 IRC	Plan# 2470 2-story SFR w/attached gara		2005
New	Approved basic 05-121152 BP	2003 IRC	Plan# 2791 2-story sfr w/attached garage		2005
New	Approved basic 05-120420 BP	2003 IRC	Plan# 2760 2-story sfr w/attached garag		2005
New	Approved basic 05-120421 BP	2003 IRC	Plan# 2470 2-story SFR w/attached gara		2005
New	Approved basic 05-121152 BP	2003 IRC	Plan# 2791 2-story sfr w/attached garage		2005
New	Approved basic 05-121155 BP	2003 IRC	Plan# 2414 Rambler w/attached garage		2005
New	Approved basic 05-121154 BP	2003 IRC	Plan# 2500 Rambler w/attached garage		2005
New	Approved basic 05-121155 BP	2003 IRC	Plan# 2414 Rambler w/attached garage		2005
New	2 story single family with semi finished daylight basement and 3 car garage				2005
New	2 story w/ attchd 3 car garage				2005
New	Two story SFR with attached Garage				2005
New	Approved Basic 05-121907-BP	2003 IRC	SFR w/attached garage	Plan: 2700	2005
New	Approved basic #04-116876 BP		Plan 2268A Rambler w/attached garage		2005
New	Approved Basic 04-121278BP	2003 IRC	SFR w/attached garage	Plan:2846-B	2005
New	Approved basic #04-116876 BP		Plan 2268A Rambler w/attached garage		2005
New	Approved BASIC 05-122244BP	2003 IRC	Rambler style SFR w/attached garage	Plan: 24	2005
New	Approved Basic 04-121278BP	2003 IRC	SFR w/attached garage	Plan:2846-B	2005
New	Approved Basic 05-121907BP	2003 IRC	SFR w/attached garage	Plan: 2700	2005
New	Approved Basic 04-121278BP	2003 IRC	SFR w/attached garage	Plan:2846-B	2005
New	Approved Basic 05-122244BP	2003 IRC	Rambler style SFR w/attached garage	Plan: 244	2005
New	2440 sq ft SFR with 1110 sq ft unfinished Basement				2005
New	2-Story SFR w/attached garage.				2005
New	Approved Basic 05-100835BP	2003 IRC		Plan:Victoria	2005
New	Approved Basic 05-100835BP	2003 IRC		Plan:Victoria	2005
New	Approved Basic 05-101255BP	2003 IRC		Plan:Hamilton	2005
New	Approved Basic 05-101255BP	2003 IRC		Plan:Hamilton	2005

Accessory Dwelling Units

Index # - File Name: 1.0022 - Single Family Dwellings Data\_Snohomish County.pdf

New	Approved Basic 05-101253BP		2003 IRC	Plan:Madison	2005
New	Approved Basic 05-101255BP	2003 IRC	2 story SFR w/semifinished bsmt & attached garag		2005
New	Approved Basic 05-101253BP		2003 IRC	Plan:Madison	2005
New	Approved Basic 05-101255BP	2003 IRC	2 story SFR w/semifinished bsmt & attached garag		2005
New	Approved Basic 05-101253BP		2003 IRC	Plan:Madison	2005
New	Approved Basic 05-101255BP	2003 IRC	2 story SFR w/semifinished bsmt & attached garag		2005
New	Approved Basic 05- 101658BP		2003 IRC	Plan:GV 38-	2005
New	Approved Basic 05- 101658BP		2003 IRC	Plan:GV 38-	2005
New	Approved Basic 05-101252BP		2003 IRC	Plan:Rainier	2005
New	Approved Basic 05-101258BP		2003 IRC	Plan:Bentley	2005
New	Approved Basic 05- 100830BP		2003 IRC	Plan:Newport	2005
New	Approved Basic 05-100837BP		2003 IRC	Plan:Kincade	2005
New	Approved Basic 05-100837BP		2003 IRC	Plan:Kincade	2005
New	Approved Basic 05-100837BP		2003 IRC	Plan:Kincade	2005
New	Approved Basic 05- 101658BP		2003 IRC	Plan:GV 38-	2005
New	Approved Basic 05- 100830BP		2003 IRC	Plan:Newport	2005
New	Approved Basic 05- 100830BP		2003 IRC	Plan:Newport	2005
New	Approved Basic 05-101258BP		2003 IRC	Plan:Bentley	2005
New	Approved Basic 05- 101261BP		2003 IRC	Plan:Danbury	2005
New	Approved Basic 05-100839BP		2003 IRC	Plan:Tuscany	2005
New	Approved Basic 05-101255BP	2003 IRC	2 story SFR w/semifinished bsmt & attached garag		2005
New	Approved Basic 05-100839BP		2003 IRC	Plan:Tuscany	2005
New	2-Story SFR w/attached garage.				2005
New	Detached Accessory Apt - 845 sqft liv g space w/ 1840 sqft garage with 560 SF 2nd Floor Storage				2005
New	Double-wide MH 2006 27 x 56				2005
New	Approved basic 05-125156 BP	2003 IRC	Plan# 2700	2-story sfr w/attached g	2005
New	Rambler style w/garage & finished basement				2005
New	Two-story sfr with attached garage				2005
New	Rambler style w/finished basement & garage				2005
New	2-story SFR w/garage				2005
New	Two story SFR with attached Garage				2005
New	Two-story SFR with attached Garage				2005
New	One-story SFR w/unfinished basement	BFE=221	NGVD		2005
New	2 - story sfr w/attached garage				2005
New	2-Story SFR w/attached garage and bonus room on 2nd floor of garage and 184 sq ft storage.				2005
New	27 x 57 Marlette 2005				2005
New	1936 sq ft SFR with unfinished Basement & attached Garage				2005
New	One-story SFR				2005
New	Rambler with Attached Garage				2005
New	Two Story SFR with Attached Garage				2005
New	Two Story SFR with Attached Garage				2005
New	Approved Basic 05-120109BP	2003 IRC	2 story SFR w/attached garage	Plan:3025A	2005
New	Approved basic 05-120613BP	2003 IRC	Plan # 4916-A	2-story sfr w/attached garag	2005
New	Approved Basic 05-120103BP	2003 IRC	2 story SFR w/attached garage	Plan:4021-(	2005
New	Approved Basic 05-120106BP	2003 IRC	2 story SFR w/attached garage	Plan:30	2005
New	Approved basic 05-121189 BP	2003 IRC	Plan# 4010DB-A	2-story sfr w/attached gara	2005
New	Approved Basic 05-120109BP	2003 IRC	2 story SFR w/attached garage	Plan:3025A	2005

Accessory Dwelling Units

Index # - File Name: 1.0022 - Single Family Dwellings Data\_Snohomish County.pdf

New	Approved	Basic 05-120102BP	2003 IRC	2 story SFR w/attached garage	Plan:4021-A	2005
New	Approved	Basic 05-120105BP	2003 IRC	2 story SFR w/attached garage	Plan:30	2005
New	Approved	Basic 05-124413BP	2003 IRC	2 story SFR w/attached garage	Plan:5025	2005
New	Approved	basic 05-121185 BP	2003 IRC	Plkan#4010D-A	2 story sfr w/attached gara	2005
New	Approved	basic 05-120611 BP	2003 IRC	Plan # 4916 - B	2 story sfr w/attached gara	2005
New	Approved	basic 05-121191 BP	2003 IRC	Plan# 4010DB-C	2-story sfr w/attached ga	2005
New	Approved	Basic 05-119825BP	2005 IRC	2 story SFR w/attached garage	Plan:3026	2005
New	Approved	Basic 05-122718BP	2003 IRC	2 story SFR w/attached garage	Plan:5025L-A	2005
New	Approved	basic 05-121182 BP	2003 IRC	Plan# 3006B-A	2 story sfr w/attached garag	2005
New	Approved	basic 05-120611 BP	2003 IRC	Plan # 4916 - B	2 story sfr w/attached gara	2005
New	Approved	Basic 05-126191BP	2003 IRC	2 story SFR w/attached basic	Plan:3006B-	2005
New	Approved	Basic 05-120105BP	2003 IRC	2 story SFR w/attached garage	Plan:30	2005
New	Approved	basic 05-121183BP	2003 IRC	Plan# 3006B-B	2-story sfr w/attached gar	2005
New	Approved	Basic 05-119824BP	2003 IRC	2 story SFR w/attached garage	Plan:3026A	2005
New	Approved	basic 05-121188 BP	2003 IRC	Plan# 4010D-C	2-story sfr w/attached garag	2005
New	Approved	Basic 05-120108BP	2003 IRC	2 story SFR w/attached garage	Plan:3027I	2005
New	Approved	Basic 05-123535BP	2003 IRC	2 story SFR w/attached garage	Plan:50	2005
New	Approved	Basic 05-120110BP	2003 IRC	2 story SFR w/attached garage	Plan:302	2005
New	Approved	basic 05-121189 BP	2003 IRC	Plan# 4010DB-A	2-story sfr w/attached gara	2005
New	Approved	basic 05-120611 BP	2003 IRC	Plan # 4916 - B	2 story sfr w/attached gara	2005
New	Approved	Basic 05-122718BP	2003 IRC	2 story SFR w/attached garage	Plan:5025L-A	2005
New	Approved	Basic 05-120108BP	2003 IRC	2 story SFR w/attached garage	Plan:3027I	2005
New	Approved	basic 05-121191 BP	2003 IRC	Plan# 4010DB-C	2-story sfr w/attached ga	2005
New	Approved	basic 05-120613BP	2003 IRC	Plan # 4916-A	2-story sfr w/attached garag	2005
New	Approved	Basic 05-123534BP	2003 IRC	2 story SFR w/attached garage	Plan:5025	2005
New	Approved	Basic 05-120106BP	2003 IRC	2 story SFR w/attached garage	Plan:30	2005
New	Approved	Basic 05-119824BP	2003 IRC	2 story SFR w/attached garage	Plan:3026A	2005
New	Approved	basic 05-121190 BP	2003 IRC	Plan# 4010DB-B	2-story sfr w/attached gara	2005
New	Approved	basic 05-120611 BP	2003 IRC	Plan # 4916 - B	2 story sfr w/attached gara	2005
New	Approved	Basic 05-120102BP	2003 IRC	2 story SFR w/attached garage	Plan:4021-A	2005
New	Approved	Basic 05-123005BP	2003 IRC	2 story SFR w/attached garage	Plan:4010	2005
New	Approved	Basic 05-119825BP	2005 IRC	2 story SFR w/attached garage	Plan:3026	2005
New	Approved	basic 05-121187 BP	2003 IRC	Plan#4010D-B	2-story sfr w/attached garag	2005
New	Approved	basic 05-120611 BP	2003 IRC	Plan # 4916 - B	2 story sfr w/attached gara	2005
New	Approved	Basic 05-122718BP	2003 IRC	2 story SFR w/attached garage	Plan:5025L-	2005
New	Approved	basic 05-121182 BP	2003 IRC	Plan# 3006B-A	2 story sfr w/attached garag	2005
New	Approved	basic 05-121192 BP	2003 IRC	Plan# 4021-B	2-story sfr w/attached garage	2005
New	Approved	Basic 05-120107BP	2003 IRC	2 story SFR w/attached garage	Plan:3027-B	2005
New	Approved	Basic 05-119824BP	2003 IRC	2 story SFR w/attached garage	Plan:3026A	2005
New	Approved	Basic 05-120106BP	2003 IRC	2 story SFR w/attached garage	Plan:30	2005
New	Approved	Basic 05-126194BP	2003 IRC	2 story SFR w/attached garage	Plan:3006-A	2005
New	Approved	Basic 05-120110BP	2003 IRC	2 story SFR w/attached garage	Plan:302	2005
New	Approved	Basic 05-126191BP	2003 IRC	2 story SFR w/attached basic	Plan:3006B-	2005
New	Approved	Basic 05-126391BP	2003 IRC	2 story SFR w/attached garage	Plan:4010B-E	2005
New	Approved	basic 05-121192 BP	2003 IRC	Plan# 4021-B	2-story sfr w/attached garage	2005
New	Approved	Basic 05-120110BP	2003 IRC	2 story SFR w/attached garage	Plan:302	2005
New		2-story sfr w/attached garage				2005

Accessory Dwelling Units

Index # - File Name: 1.0022 - Single Family Dwellings Data\_Snohomish County.pdf

New	Two-story SFR					2005
New	Approved basic 05-125057 BP	2003 IRC	Plan # 2433 A & B	2-story sfr w/attached ga		2005
New	Approved basic 05-124883 BP	2003 IRC	Plan# 2423-A & B	2-story sfr w/attached		2005
New	Approved basic 05-125058 BP	2003 IRC	Plan# 2604 A & B	2-story sfr w/attached		2005
New	Two-story sfr with attached garage					2005
New	Approved basic 05-125057 BP	2003 IRC	Plan # 2433 A & B	2-story sfr w/attached ga		2005
New	Approved basic 05-125057 BP	2003 IRC	Plan # 2433 A & B	2-story sfr w/attached ga		2005
New	Approved basic 05-124883 BP	2003 IRC	Plan# 2423-A & B	2-story sfr w/attached g		2005
New	Approved basic 05-125058 BP	2003 IRC	Plan# 2604 A & B	2-story sfr w/attached g		2005
New	Approved basic 05-125058 BP	2003 IRC	Plan# 2604 A & B	2-story sfr w/attached g		2005
New	Approved Basic 04-116301BP	2 story SFR w/attached garage	2003 IRC	Plan:2590		2005
New	Two-story sfr with attached garage					2005
New	Approved basic 05-125057 BP	2003 IRC	Plan # 2433 A & B	2-story sfr w/attached ga		2005
New	Approved basic 05-124883 BP	2003 IRC	Plan# 2423-A & B	2-story sfr w/attached		2005
New	Approved basic 05-125057 BP	2003 IRC	Plan # 2433 A & B	2-story sfr w/attached ga		2005
New	Approved basic 05-125058 BP	2003 IRC	Plan# 2604 A & B	2-story sfr w/attached		2005
New	Approved basic 05-124883 BP	2003 IRC	Plan# 2423-A & B	2-story sfr w/attache		2005
New	Approved basic 05-125057 BP	2003 IRC	Plan # 2433 A & B	2-story sfr w/attached ga		2005
New	Approved basic 05-125057 BP	2003 IRC	Plan # 2433 A & B	2-story sfr w/attached ga		2005
New	Approved basic 05-125058 BP	2003 IRC	Plan# 2604 A & B	2-story sfr w/attached		2005
New	Approved Basic 04- 119008BP		Plan: 2488	Two-story SFR with attached 2-		2005
New	2,725 sf Rambler with attached garage					2005
New	1 story SFR w/attached garage	2003 IRC				2005
New	Approved Basic 04-116301BP	2 story SFR w/attached garage	2003 IRC	Plan:2590		2005
New	Approved basic 05-125057 BP	2003 IRC	Plan # 2433 A & B	2-story sfr w/attached ga		2005
New	Approved basic 05-124883 BP	2003 IRC	Plan# 2423-A & B	2-story sfr w/attache		2005
New	Duplex with attached Garage					2005
New	Two Story SFR with Attached Garage					2005
New	2-Story SFR w/attached garage.	2003 IRC				2005
New	Approved basic 05-123201 BP	2003 IRC	Plan # M2415A3F-5	2 story SFR w/ attchd ga		2005
New	Approved basic 05-123201 BP	2003 IRC	Plan # M2415A3F-5	2 story SFR w/att garage		2005
New	Approved Basic 05-122459 BP	2003 IRC	Two-story SFR	Plan:M2520		2005
New	Approved basic 05-123201 BP	2003 IRC	Plan # M2415A3F-5	2 story SFR w/ attachd gar		2005
New	Approved Basic 05-122459 BP	2003 IRC	Two-story SFR	Plan:M2520		2005
New	2-Story SFR w/attached garage	2003 IRC				2005
New	Approved basic 05-126370 BP	2003 IRC	Plan # 226-1007	2-story sfr w/attached gara		2005
New	Approved basic 05-1296374 BP	2003 IRC	Plan # 2394	2-story sfr w/attached garage		2005
New	Approved basic 05-1296374 BP	2003 IRC	Plan # 2394	2-story sfr w/attached garage		2005
New	Approved basic 05-126370 BP	2003 IRC	Plan # 226-1007	2-story sfr w/attached gara		2005
New	Approved basic 05-1296374 BP	2003 IRC	Plan # 2394	2-story sfr w/attached garage		2005
New	Approved basic 05-1296374 BP	2003 IRC	Plan # 2394	2-story sfr w/attached garage		2005
New	Approved basic 05-126370 BP	2003 IRC	Plan # 226-1007	2-story sfr w/attached gara		2005
New	Approved basic 05-1296374 BP	2003 IRC	Plan # 2394	2-story sfr w/attached garage		2005
New	Approved basic 05-1296374 BP	2003 IRC	Plan # 2394	2-story sfr w/attached garage		2005
New	Approved basic 05-1296374 BP	2003 IRC	Plan # 2394	2-story sfr w/attached garage		2005
New	Approved basic 05-1296374 BP	2003 IRC	Plan # 2394	2-story sfr w/attached garage		2005
New	Approved basic 05-1296374 BP	2003 IRC	Plan # 2394	2-story sfr w/attached garage		2005
New	Two-story sfr with attached garage					2005

Accessory Dwelling Units

Index # - File Name: 1.0022 - Single Family Dwellings Data\_Snohomish County.pdf

New	1760 sf Rambler					2005
New	Approved basic 05-126366 BP	2003 IRC	Plan # 226-1005	2-story sfr w/attached gar		2005
New	Approved basic 05-126368 BP	2003 IRC	Plan # 226-1002	2-story sfr w/attached gara		2005
New	Approved basic 05-126373 BP	2003 IRC	Plan # 226-1001	2-story sfr w/attached gara		2005
New	Approved basic 05-126367 BA	2003 IRC	Plan# 226-1004	2-story sfr w/attached garag		2005
New	Approved basic 05-126366 BP	2003 IRC	Plan # 226-1005	2-story sfr w/attached gar		2005
New	Approved basic 05-126373 BP	2003 IRC	Plan # 226-1001	2-story sfr w/attached gara		2005
New	Approved basic 05-126367 BA	2003 IRC	Plan# 226-1004	2-story sfr w/attached garag		2005
New	Approved basic 05-126373 BP	2003 IRC	Plan # 226-1001	2-story sfr w/attached gara		2005
New	Approved basic 05-126366 BP	2003 IRC	Plan # 226-1005	2-story sfr w/attached gar		2005
New	Approved basic 05-126368 BP	2003 IRC	Plan # 226-1002	2-story sfr w/attached gara		2005
New	Approved basic 05-126365 BP	2003 IRC	Plan# 226-1003	2-story sfr w/attached gi		2005
New	Approved basic 05-126368 BP	2003 IRC	Plan # 226-1002	2-story sfr w/attached gara		2005
New	Approved basic 05-1296374 BP	2003 IRC	Plan # 2394	2-story sfr w/attached garage		2005
New	Approved basic 05-1296374 BP	2003 IRC	Plan # 2394	2-story sfr w/attached garage		2005
New	Approved basic 05-1296374 BP	2003 IRC	Plan # 2394	2-story sfr w/attached garage		2005
New	Approved basic 05-1296374 BP	2003 IRC	Plan # 2394	2-story sfr w/attached garage		2005
New	Approved basic 05-1296374 BP	2003 IRC	Plan # 2394	2-story sfr w/attached garage		2005
New	Approved Basic 05-124813 BP	2003 IRC	2 story SFR w/attached garage	Plan:1720 3		2005
New	Approved basic 05-120159 BP	2003 IRC	Plan# TS JEB	2 story SFR w/attached gar		2005
New	*issued under tax roll # 003737-008-015-00*		2-story sfr w/attached garage			2005
New	*issued under tax roll # 003737-008-015-00*		2-story sfr w/attached garage	(lot 3)		2005
New	*issued under tax roll # 003737-008-015-00*		2-story sfr w/attached garage			2005
New	*issued under tax roll # 003737-008-015-00*		2- story sfr w/attached garage			2005
New	*issued under tax roll # 003737-008-015-00*		2-story sfr w/attached garage			2005
New	*issued under tax roll # 003737-008-015-00*		2-story sfr w/attached garage			2005
New	2005 54 X 26 8 Double Wide MH					2005
New	Approved Basic 05-122829BP	2003 IRC	2 story SFR w/attached garage	Plan:1809		2005
New	2 story w/ attchd. garage As of 10/18/06 it is ok to final the SFR and the prescribed paved area.					2005
New	Approved Basic 05-122829BP	2003 IRC	2 story SFR w/attached garage	Plan:1809		2005
New	Approved Basic 05- 123059BP		2003 IRC	Plan: 2160 Two-story SFR w		2005
New	Approved Basic 05- 123059BP		2003 IRC	Plan: 2160 Two-story SFR w		2005
New	Approved Basic 05-122831BP	2003 IRC	2 story SFR w/attached garage	Plan:2026		2005
New	Approved Basic 05- 123059BP		2003 IRC	Plan: 2160 Two-story SFR w		2005
New	Approved Basic 05-122829BP	2003 IRC	2 story SFR w/attached garage	Plan:1809		2005
New	Approved Basic 05-122829BP	2003 IRC	2 story SFR w/attached garage	Plan:1809		2005
New	Approved Basic 05- 123059BP		2003 IRC	Plan: 2160 Two-story SFR w		2005
New	Approved Basic 05-122827BP	2003 IRC	2 story SFR w/attached garage	Plan:1878		2005
New	Approved Basic 05-122827BP	2003 IRC	2 story SFR w/attached garage	Plan:1878		2005
New	Approved Basic 05-122831BP	2003 IRC	2 story SFR w/attached garage	Plan:2026		2005
New	Approved Basic 05- 123059BP		2003 IRC	Plan: 2160 Two-story SFR w		2005
New	Approved Basic 05-124781 BP	2003 IRC	Plan# 35011-A2	2-story sfr w/attached gara		2005
New	Approved basic 05-123556 BP	2003 IRC	Plan# 30030-A2	2-story sfr w/attached ;		2005
New	Approved basic 05-123555 BP	2003 IRC	Plan# 30010-A2	2-story sfr w/attached gar		2005
New	Approved basic 05-124782 BP	2003 IRC	Plan #50065-A2	2-story sfr w/attached gara		2005
New	Approved basic 05-124782 BP	2003 IRC	Plan #50065-A2	2-story sfr w/attached gara		2005
New	Approved basic 05-127403 BP	2003 IRC	Plan# 50060 A-2	2-story sfr w/attached gara		2005

Accessory Dwelling Units

Index # - File Name: 1.0022 - Single Family Dwellings Data\_Snohomish County.pdf

New	Approved	basic 05-124782 BP	2003 IRC	Plan #50065-A2	2-story sfr w/attached gara	2005
New	Approved	basic 05-127403 BP	2003 IRC	Plan# 50060 A-2	2-story sfr w/attached g	2005
New	Approved	basic 05-124323 BP	2003 IRC	Plan#30020-A2	2-story sfr w/attache	2005
New	Approved	basic 05-123556 BP	2003 IRC	Plan# 30030-A2	2-story sfr w/attached g	2005
New	Approved	basic 05-123555 BP	2003 IRC	Plan# 30010-A2	2-story sfr w/attached gar	2005
New	Approved	basic 05-123556 BP	2003 IRC	Plan# 30030-A2	2-story sfr w/attached g	2005
New	Approved	basic 05-123555 BP	2003 IRC	Plan# 30010-A2	2-story sfr w/attached ga	2005
New	Approved	basic 05-123556 BP	2003 IRC	Plan# 30030-A2	2-story sfr w/attached g	2005
New	Approved	basic 05-123555 BP	2003 IRC	Plan# 30010-A2	2-story sfr w/attached gar	2005
New	Approved	basic 05-123556 BP	2003 IRC	Plan# 30030-A2	2-story sfr w/attached g	2005
New	Approved	Basic 05-124781 BP	2003 IRC	Plan# 35011-A2	2-story sfr w/attached gara	2005
New	Approved	basic 05-123555 BP	2003 IRC	Plan# 30010-A2	2-story sfr w/attached gar	2005
New	approved	basic 05-123556 BP	2003 IRC	Plan# 30030-A2	2-story sfr w/attached g	2005
New	Approved	Basic 05-124781 BP	2003 IRC	Plan# 35011-A2	2-story sfr w/attached gara	2005
New	Approved	basic 05-124781 BP	2003 IRC	Plan# 35011-A2	2-story sfr w/attached gara	2005
New	Approved	basic 05-127402 BP	2003 IRC	Plan # 50055 A-2	2-story sfr w/attached gara	2005
New	Approved	Basic 05-122829BP	2003 IRC	2 story SFR w/attached garage	Plan:1809	2005
New	Approved	Basic 05-122831BP	2003 IRC	2 story SFR w/attached garage	Plan:2026	2005
New	Approved	Basic 05-122829BP	2003 IRC	2 story SFR w/attached garage	Plan:1809	2005
New	Approved	Basic 05-122829BP	2003 IRC	2 story SFR w/attached garage	Plan:1809	2005
New	Approved	Basic 05-122829BP	2003 IRC	2 story SFR w/attached garage	Plan:1809	2005
New		Marlette Mobile home				2005
New		Two story SFR with attached Garage				2005
New		*issued under tax roll # 003737-008-004-01*		2-story sfr w/attached garage		2005
New		*issued under tax roll # 003737-008-004-01*		2-story sfr w/attached garage		2005
New		2 story SFR w/ attchd Garage				2005
New	Approved	basic 05-101398 BP	2003 IRC	Plan # 3259-3	2 story sfr w/attached garag	2005
New		2 story SFR w/ attached 3 car garage				2005
New	Approved	basic 05-101398 BP	2003 IRC	Plan # 3259-3	2 story sfr w/attached garag	2005
New		Two story SFR with attached Garage				2005
New	Approved	Basic #05-124117 BP	2003 IRC	2 story SFR w/attached garage	Plan:3101	2005
New	Approved	Basic 05-126102BP	2003 IRC	2 story SFR w/attached garage	Plan:2147	2005
New	Approved	Basic 05-126102BP	2003 IRC	2 story SFR w/attached garage	Plan:2147	2005
New	Approved	Basic 04-117091BP		Plan: 2104B	Two-story SFR with attached ga	2005
New	Approved	Basic 04-117091BP		Plan: 2104B	Two-story SFR with attached ga	2005
New	Approved	Basic 05-126102BP	2003 IRC	2 story SFR w/attached garage	Plan:2147	2005
New	Approved	Basic 05-126102BP	2003 IRC	2 story SFR w/attached garage	Plan:2147	2005
New	Approved	Basic 05-126102BP	2003 IRC	2 story SFR w/attached garage	Plan:2147	2005
New	Approved	Basic 05-126094BP	2003 IRC	2 story SFR w/attached garage	Plan:2104H	2005
New	Approved	Basic 05-126102BP	2003 IRC	2 story SFR w/attached garage	Plan:2147	2005
New	Approved	Basic 04-117091BP		Plan: 2104B	Two-story SFR with attached ga	2005
New	Approved	Basic 05-126099BP	2003 IRC	2 story SFR w/attached garage	Plan:1598	2005
New	Approved	Basic 05-121624BP	2003 IRC	2 story SFR w/ attached garage	Plan:1733	2005
New	Approved	Basic 05-126099BP	2003 IRC	2 story SFR w/attached garage	Plan:1598	2005
New	Approved	Basic 05-121624BP	2003 IRC	2 story SFR w/ attached garage	Plan:1733	2005
New	Approved	Basic 05-123957BP	2003 IRC	Plan:1852	SFR w/finished basement & attache	2005
New	Approved	Basic 04-117091BP		Plan: 2104B	Two-story SFR with attached ga	2005

Accessory Dwelling Units

Index # - File Name: 1.0022 - Single Family Dwellings Data\_Snohomish County.pdf

New	Approved Basic 05-121624BP	2003 IRC	2 story SFR w/ attached garage	Plan:1733	2005
New	Approved Basic 05-126099BP	2003 IRC	2 story SFR w/attached garage	Plan:1598	2005
New	Approved Basic 05-123957BP	2003 IRC	Plan:1852 SFR w/finished basement & attache		2005
New	Approved Basic 05-123957BP	2003 IRC	Plan:1852 SFR w/finished basement & attache		2005
New	Approved Basic 05-126099BP	2003 IRC	2 story SFR w/attached garage	Plan:1598	2005
New	Approved Basic 05-123957BP	2003 IRC	Plan:1852 SFR w/finished basement & attache		2005
New	Approved Basic 05-126099BP	2003 IRC	2 story SFR w/attached garage	Plan:1598	2005
New	Approved Basic 05-123957BP	2003 IRC	Plan:1852 SFR w/finished basement & attache		2005
New	Approved Basic 05-121624BP	2003 IRC	2 story SFR w/ attached garage	Plan:1733	2005
New	Approved Basic 05-126099BP	2003 IRC	2 story SFR w/attached garage	Plan:1598	2005
New	Approved Basic 05-121624BP	2003 IRC	2 story SFR w/ attached garage	Plan:1733	2005
New	Approved Basic 05-123957BP	2003 IRC	Plan:1852 SFR w/finished basement & attache		2005
New	heated storage above garage and 150 ft covered porch				2005
New	160 sq ft bump out (expanding 1 sq ft out of original footprint)				2005
New	Two story SFR with attached Garage				2005
New	Approved Basic 05-121624BP	2003 IRC	2 story SFR w/ attached garage	Plan:1733	2005
New	PERMIT VOIDED AND PLACED IN 05-124690RK. gb 9/28/05 Approved Basic 04-117091BP				2005
New	Approved Basic 05-121624BP	2003 IRC	2 story SFR w/ attached garage	Plan:1733	2005
New	Approved Basic 05-126102BP	2003 IRC	2 story SFR w/attached garage	Plan:2147	2005
New	Approved Basic 05-126102BP	2003 IRC	2 story SFR w/attached garage	Plan:2147	2005
New	2-Story SFR w/attached garage.				2005
New	Approved Basic 05-126102BP	2003 IRC	2 story SFR w/attached garage	Plan:2147	2005
New	Rambler style SFR w/attached garage.				2005
New	Rambler style w/garage				2005
New	Rambler style w/garage				2005
New	2-Story SFR w/7 x 19 Breezeway attached to 20 x 28 garage w/500-sq. ft. 2-nd story storage ar				2005
New	BASIC CAN ONLY BE USED IN ZONING ALLOWING 30 HEIGHT Approved Basic 05-122760BP 20				2005
New	Two story SFR with attached Garage				2005
New	Approved basic 05-124305 BP	2003 IRC	Plan# 0123 2-story sfr w/attached gar		2005
New	Approved Basic 05- 122321BP	2003 IRC	2 story SFR w/attached garage	Plan: 252	2005
New	Approved Basic 05-125238BP	2003 IRC	2 story SFR w/attached garage	Plan:3041	2005
New	Approved Basic 04-115827BP	2003 IRC	2 story SFR w/attached garage	2003 IRC Plan:2968	2005
New	Approved basic 05-118084 BP	2003 IRC	Plan# 3048 2-story sfr w/attached garage		2005
New	SFR with 566 SF Finished Basement and Attached Garage PLAN 1758				2005
New	Approved Basic 05-128071 BP	2003 IRC	2 story SFR w/attached garage	Plan: 29	2005
New	2-story sfr w/attached garage				2005
New	Approved basic 05-125304 BP	2003 IRC	Plan # 2969 2-story sfr w/attached gara		2005
New	Approved basic 05-125310 BP	2003 IRC	Plan# 3006 2-story sfr w/attached garage		2005
New	2-story sfr w/attached garage				2005
New	Approved basic 05-124781 BP	2003 IRC	Plan# 35011-A2 2-story sfr w/attached gara		2005
New	Approved Basic 05-100164BP	2003 IRC	Plan: 40040-A2S Two-story SFR wi		2005
New	Approved basic 05-129117 BP	2003 IRC	Plan# 45010-A-3 2-story sfr w/attached gar		2005
New	Approved Basic 04-115137BP	2003 IRC	2 story SFR w/attached garage	2003 IRC Plan:50070-A3T	2005
New	Approved basic 05-124781 BP	2003 IRC	Plan# 35011-A2 2-story sfr w/attached gara		2005
New	Approved basic 05-129117 BP	2003 IRC	Plan# 45010-A3 2-story sfr w/attached gar		2005
New	Approved Basic 04-115849BP	2003 IRC	2 story SFR w/attached garage	2003 IRC Plan:40030-A3T	2005
New	Approved basic 05-129117 BP	2003 IRC	Plan# 45010-A3 2-story sfr w/attached gara		2005

Accessory Dwelling Units

Index # - File Name: 1.0022 - Single Family Dwellings Data\_Snohomish County.pdf

New	Approved basic 05-124781 BP	2003 IRC	Plan# 35011-A2	2-story sfr w/attached garage	2005
New	Approved basic 05-127403 BP	2003 IRC	Plan# 50060 A-2	2-story sfr w/attached garage	2005
New	Approved Basic 04-115845BP	2003 IRC	Plan:70010-A4T	2 story SFR w/attached garage	2005
New	Approved basic 05-126970 BP	2003 IRC	Plan# 40050-A2	2-story sfr w/attached garage	2005
New	Approved Basic 04-114800BP		Plan: 40020-A2	Two-story SFR - 2003 IRC	2005
New	Approved Basic 04-115845BP	2003 IRC	Plan:70010-A4T	2 story SFR w/attached garage	2005
New	Approved Basic 04-115137BP	2003 IRC	Plan:50070-A3T	2 story SFR w/attached garage	2005
New	2 - story sfr w/attached garage				2005
New	Approved Basic 05-127366 BP	2003 IRC	Plan: 3008	2 story SFR w/attached garage	2005
New	Two-story SFR				2005
New	Approved Basic 05-125782BP	2003 IRC	Plan:2946	Two story SFR with attached Garage	2005
New	Approved Basic 05-125782BP	2003 IRC	Plan:2946	Two story SFR with attached Garage	2005
New	Approved Basic 05-125782BP	2003 IRC	Plan:2946	Two story SFR with attached Garage	2005
New	Two-story sfr with attached garage	2003 IRC			2005
New	Two-story sfr with attached garage	2003 IRC			2005
New	Approved Basic 05-125299BP	2003 IRC	Plan:2452	2 story SFR w/attached garage	2005
New	Approved Basic 05-126594BP	2003 IRC	Plan:1775	2 story SFR w/attached garage	2005
New	Approved Basic 05-126597BP	2005 IRC	Plan:1759	2 story SFR w/attached garage	2005
New	Approved Basic 05-125785BP	2003 IRC	Plan:1935	Two story SFR with attached Garage	2005
New	Approved Basic 05-125299BP	2003 IRC	Plan:1906	2 story SFR w/attached garage	2005
New	Approved Basic 05-127366 BP	2003 IRC	Plan: 3008	2 story SFR w/attached garage	2005
New	Two story SFR				2005
New	Rambler style w/garage				2005
New	Two story SFR w/semi-finished basement				2005
New	2606sf Tri-level SFR with attached garage	2003 IRC			2005
New	Approved Basic 05-125238BP	2003 IRC	Plan:3041	2 story SFR w/attached garage	2005
New	Two-story SFR with garage & basement garage				2005
New	Approved Basic #04-115976BP			Rambler with Attached Garage	2005
New	Approved Basic 04-115827BP	2003 IRC	Plan:2968	2 story SFR w/attached garage	2005
New	Approved Basic 05-101013BP	2003 IRC	Plan: 2722		2005
New	Approved Basic 04-115824BP	2003 IRC	Plan:2611	2 story SFR w/attached garage	2005
New	Approved Basic 05-125238BP	2003 IRC	Plan:3041	2 story SFR w/attached garage	2005
New	2-story sfr w/attached garage	2003 IRC	Plan:3175		2005
New	Approved basic 05-124400 BP	2003 IRC	Plan# 3098	2-story sfr w/attached garage	2005
New	Approved basic 05-126197 BP	2003 IRC	Plan# 2620	2-story sfr w/attached garage	2005
New	Approved basic 05-119649 BP	2003 IRC	Plan # 2588	2 story sfr w/attached garage	2005
New	Approved basic 05-119652 BP	2003 IRC	Plan# 3066	2-story SFR w/attached garage	2005
New	Approved Basic 04-115826BP	2003 IRC	Plan:2783	2 story SFR w/attached garage	2005
New	Approved Basic 04-115824BP	2003 IRC	Plan:2611	2 story SFR w/attached garage	2005
New	Approved basic 05-124400 BP	2003 IRC	Plan# 3098	2-story sfr w/attached garage	2005
New	Approved Basic 04-115827BP	2003 IRC	Plan:2968	2 story SFR w/attached garage	2005
New	Approved Basic 04-120732BP	2003 IRC		SFR with Finished Basement and Attached Garage	2005
New	Approved basic 05-117305 BP	2003 IRC	Plan# 0419-A	2-story sfr w/attached garage	2005
New	Approved basic 05-117305 BP	2003 IRC	Plan# 0419-A	2-story sfr w/attached garage	2005
New	Approved basic 05-117305 BP	2003 IRC	Plan# 0419-A	2-story sfr w/attached garage	2005
New	Approved Basic #04-118802			SFR with Attached Garage	2005
New	Approved basic 05-117305 BP	2003 IRC	Plan# 0419-A	2-story sfr w/attached garage	2005



Accessory Dwelling Units

Index # - File Name: 1.0022 - Single Family Dwellings Data\_Snohomish County.pdf

New	Approved	Basic 05-117307 BP	2003 IRC	Plan# 2195A2F 10	Split entry w/attached	2005
New	Approved	Basic 05-126891BP	2003 IRC	2 story SFR w/attached garage	Plan:2840A	2005
New	Approved	Basic 05-126965BP	2003 IRC	2 story SFR w/attached garage	Plan:2564A	2005
New	Approved	Basic 05-126895BP	2003 IRC	2 story SFR w/attached garage	Plan:2733	2005
New	Approved	Basic 05-126963BP	2003 IRC	2 story SFR w/attached garage	Plan:2672A	2005
New	Approved	Basic 05-126965BP	2003 IRC	2 story SFR w/attached garage	Plan:2564A	2005
New	Approved	Basic 05-126964BP	2003 IRC	2 story SFR w/attached garage	Plan:2672B	2005
New	Approved	Basic 05-126894BP	2003 IRC	2 story SFR w/attached garage	Plan:2733	2005
New	Approved	Basic 05-126895BP	2003 IRC	2 story SFR w/attached garage	Plan:2733	2005
New		2-story sfr w/attached garage				2005
New		Rambler with Attached Garage				2005
New	Approved	Basic 05-126182BP	2003 IRC	2 story SFR w/attached garage	Plan:1703	2005
New	Approved	Basic 05-126182BP	2003 IRC	2 story SFR w/attached garage	Plan:1703	2005
New	Approved	Basic 05-126182BP	2003 IRC	2 story SFR w/attached garage	Plan:1703	2005
New	Approved	Basic 05-126182BP	2003 IRC	2 story SFR w/attached garage	Plan:1703	2005
New	Approved	Basic 05-126182BP	2003 IRC	2 story SFR w/attached garage	Plan:1703	2005
New		2 story SFR w/attached garage	2003 IRC			2005
New		2 story Duplex w/ attached garage	2003 IRC			2005
New		2 story Duplex w/attached garage	2003 IRC			2005
New		2 story Duplex w/attached garage	2003 IRC			2005
New	Approved	Basic 05-127779BP	2003 IRC	2 story SFR w/attached garage	Plan:2278	2005
New	Approved	Basic 05-127779BP	2003 IRC	2 story SFR w/attached garage	Plan:2278	2005
New	Approved	Basic 04-116621BP	2003 IRC	2 Story SFR w/attached garage	Plan:1909	2005
New		Rambler style w/garage				2005
New		2234sf rambler with attached garage -	2003 IRC			2005
New	Approved	Basic 05-119590BP	2003 IRC	2 story SFR w/attached garage	Plan:3023A	2005
New	Approved	Basic 05-123018BP	2003 IRC	2 story SFR w/attached garage	Plan:3913B	2005
New	Approved	Basic 05-119592BP	2003 IRC	2 story SFR w/attached garage	Plan:3024B	2005
New	Approved	Basic 05-123011BP	2003 IRC	2 story SFR w/attached garage	Plan:3913B	2005
New	Approved	Basic 05-119586BP	2003 IRC	2 story SFR w/attached garage	Plan:3022E	2005
New	Approved	Basic 05-123013BP	2003 IRC	2 story SFR w/attached garage	Plan:3914A	2005
New	Approved	Basic 05-119588BP	2003 IRC	2 story SFR w/attached garage	Plan:302	2005
New	Approved	Basic 05-1203020BP	2003 IRC	2 story SFR w/attached garage	Plan:3915B	2005
New	Approved	Basic 05-123011BP	2003 IRC	2 story SFR w/attached garage	Plan:3913B	2005
New	Approved	Basic 05-123015BP	2003 IRC	2 story SFR w/attached garage	Plan:3914B	2005
New	Approved	Basic 05-119590BP	2003 IRC	2 story SFR w/attached garage	Plan:3023A	2005
New	Approved	Basic 05-123011BP	2003 IRC	2 story SFR w/attached garage	Plan:3913B	2005
New	Approved	Basic 05-119586BP	2003 IRC	2 story SFR w/attached garage	Plan:3022E	2005
New	Approved	Basic 05-1203020BP	2003 IRC	2 story SFR w/attached garage	Plan:3915B	2005
New	Approved	Basic 05-123011BP	2003 IRC	2 story SFR w/attached garage	Plan:3913B	2005
New	Approved	Basic 05-119591BP	2003 IRC	2 story SFR w/attached garage	Plan:302	2005
New	Approved	Basic 05-123011BP	2003 IRC	2 story SFR w/attached garage	Plan:3913B	2005
New	Approved	Basic 05-119584BP	2003 IRC	2 story SFR w/attached garage	Plan:3022A	2005
New	Approved	Basic 05-123015BP	2003 IRC	2 story SFR w/attached garage	Plan:3914B	2005
New	Approved	Basic 05-119588BP	2003 IRC	2 story SFR w/attached garage	Plan:302	2005
New	Approved	Basic 05-1203020BP	2003 IRC	2 story SFR w/attached garage	Plan:3915B	2005
New	Approved	Basic 05-123011BP	2003 IRC	2 story SFR w/attached garage	Plan:3913B	2005

Accessory Dwelling Units

Index # - File Name: 1.0022 - Single Family Dwellings Data\_Snohomish County.pdf

New	Approved Basic 05-119591BP	2003 IRC	2 story SFR w/attached garage	Plan:302	2005
New	Approved Basic 05-123013BP	2003 IRC	2 story SFR w/attached garage	Plan:3914A	2005
New	Approved Basic 05-123010BP	2003 IRC	2 story SFR w/attached garage	Plan:3913A	2005
New	Approved Basic 05-1203020BP	2003 IRC	2 story SFR w/attached garage	Plan:3915B	2005
New	Approved Basic 05-123015BP	2003 IRC	2 story SFR w/attached garage	Plan:3914B	2005
New	Approved Basic 05-123011BP	2003 IRC	2 story SFR w/attached garage	Plan:3913B	2005
New	Approved Basic 05-119584BP	2003 IRC	2 story SFR w/attached garage	Plan:3022A	2005
New	Approved Basic 05-123010BP	2003 IRC	2 story SFR w/attached garage	Plan:3913A	2005
New	Approved Basic 05-123015BP	2003 IRC	2 story SFR w/attached garage	Plan:3914B	2005
New	Approved Basic 05-119584BP	2003 IRC	2 story SFR w/attached garage	Plan:3022A	2005
New	Approved Basic 05-123010BP	2003 IRC	2 story SFR w/attached garage	Plan:3913A	2005
New	Approved Basic 05-119592BP	2003 IRC	2 story SFR w/attached garage	Plan:3024B	2005
New	Approved Basic 05-1203020BP	2003 IRC	2 story SFR w/attached garage	Plan:3915B	2005
New	Approved Basic # 05-122197 BP	2003 IRC	Plan: 2994		2005
New	Approved Basic 05-100019BP		2 Story SFR w/attached garage	2003 IRC Plan: N	2005
New	Approved Basic #04-115976BP		Rambler with Attached Garage		2005
New	Approved Basic 04-118493BP		Plan: 1757 Two-story SFR with attached 2-car		2005
New	Approved Basic 05-119591BP	2003 IRC	2 story SFR w/attached garage	Plan:302	2005
New	Approved Basic 05-123010BP	2003 IRC	2 story SFR w/attached garage	Plan:3913A	2005
New	Rambler style sfr w/attached garage				2005
New	Rambler style sfr w/attached garage				2005
New	Two-story SFR with attached garage and unheated garage/storage area -	2005 IRC			2005
New	Approved Basic 04-115896BP		Builders Plan #2271AC 2 Story w/ 3 Car		2005
New	Approved basic 05-128013 BP	2003 IRC	Plan# 2590	2-story sfr w/attached gara	2005
New	Approved basic 05-127862	2003 IRC	Plan # 2425	2-story sfr w/attached garage	2005
New	Approved basic 05-128017 BP	2003 IRC	Plan # 2283	2-story sfr w/attached gara	2005
New	Approved basic 05-127859 BP	2003 IRC	Plan # 2345	2-story sfr w/attached garage	2005
New	Approved basic 05-128013 BP	2003 IRC	Plan# 2590	2-story sfr w/attached gara	2005
New	Approved basic 05-127477 BP	2003 IRC	Plan# Berkshire	2-story sfr w/attached garage	2005
New	Approved basic 05-127055 BP	2003 IRC	Plan# Camden	2-story sfr w/attached garag	2005
New	Approved 05-127056 bp	2003 IRC	Plan# Brookfield	2-story sfr w/attached garag	2005
New	Approved basic 05-127053 BP	2003 IRC	Plan# Covington	2-story sfr w/attached ga	2005
New	Approved basic 05-127478 BP	2003 IRC	Plan# Leren	2-story sfr w/attached garage	2005
New	Approved basic 05-127053 BP	2003 IRC	Plan# Covington	2-story sfr w/attached ga	2005
New	Approved basic 05-127476 BP	2003 IRC	Plan # Quincy B	2-story sfr w/attached gar	2005
New	Approved 05-127056 bp	2003 IRC	Plan# Brookfield	2-story sfr w/attached garag	2005
New	Approved basic 05-127055 BP	2003 IRC	Plan# Camden	2-story sfr w/attached garag	2005
New	Approved basic 05-127053 BP	2003 IRC	Plan# Covington	2-story sfr w/attached ga	2005
New	Approved 05-127056 bp	2003 IRC	Plan# Brookfield	2-story sfr w/attached garag	2005
New	Approved basic 05-127477 BP	2003 IRC	Plan# Berkshire	2-story sfr w/attached garage	2005
New	Approved basic 05-127474 BP	2003 IRC	Plan # Quincy A	2-story sfr w/attached gar	2005
New	Approved basic 05-127055 BP	2003 IRC	Plan# Camden	2-story sfr w/attached garag	2005
New	Approved basic 05-127053 BP	2003 IRC	Plan# Covington	2-story sfr w/attached ga	2005
New	Approved basic 05-127478 BP	2003 IRC	Plan# Leren	2-story sfr w/attached garage	2005
New	Approved basic 05-127054 BP	2003 IRC	Plan# Nantucket	2-story sfr w/attached gar	2005
New	Approved basic 05-127053 BP	2003 IRC	Plan# Covington	2-story sfr w/attached ga	2005
New	Approved 05-127056 bp	2003 IRC	Plan# Brookfield	2-story sfr w/attached garag	2005

Accessory Dwelling Units

Index # - File Name: 1.0022 - Single Family Dwellings Data\_Snohomish County.pdf

New	Approved basic 05-127477 BP	2003 IRC	Plan# Berkshire	2-story sfr w/attached garage	2005
New	Rambler w/ 3 car garage				2005
New	2226 sq ft Rambler with attached Garage				2005
New	Approved Basic 05-126183BP	2003 IRC	Duplex w/attached garage	Plan:3847	2005
New	Approved Basic 05-126183BP	2003 IRC	Duplex w/attached garage	Plan:3847	2005
New	SFR Rambler with daylight basement				2005
New	SFR with Basement and attached Garage				2005
New	4 bedroom two story SFR w/ attchd. 3 car garage				2005
New	Rambler 2656 sq ft SFR w/ 3 car garage				2005
New	Rambler style SFR w/garage & semi-finished basement				2005
New	Two Strory SFR with Attached Garage	2003 IRC			2005
New	One story SFR				2005
New	One-story SFR				2005
New	SFR w/attached garage.				2005
New	1226 sq ft SFR with Attached Garage -				2005
New	2 story sfr w/attached garage				2005
New	2205 sq ft SFR with attached Garage				2005
New	SFR/ finished basement & attached garage	2003 IRC			2005
New	2 story SFR w/attached garage	2003 IRC			2005
New	Approved Basic 05-119546BP	2003 IRC	2 story SFR w/attached garage	Plan:1770/2536	2005
New	Approved Basic 05-119546BP	2003 IRC	2 story SFR w/attached garage	Plan:1770/2536	2005
New	Approved Basic 05-119546BP	2003 IRC	2 story SFR w/attached garage	Plan:1770/2536	2005
New	2-story w/garage				2005
New	Two-story SFR - 1997 UBC		Plan: M2605A3S-0		2005
New	Two-story sfr with attached garage				2005
New	2 story single family with attached garage				2005
New	One-story rambler with attached garage				2005
New	Rambler style w/unfin basement & garage				2005
New	Approved Basic 05-118084 BP	2003 IRC	Plan# 3048	2-story sfr w/attached garage	2005
New	Approved basic 05-126197 BP	2003 IRC	Plan# 2620	2-story sfr w/attached garage	2005
New	Approved Basic 04-116048-BP	2 story SFR w/attached 3 car garage	2003 IRC	Bldr s. Plan	2005
New	Approved basic 05-118084 BP	2003 IRC	Plan# 3048	2-story sfr w/attached garage	2005
New	Rambler style SFR w/daylight basement & garage				2005
New	2805 sf Rambler w/ 797 sf of unfinished basement & 3 car attchd. garage				2005
New	Two-story sfr with garage				2005
New	2 story SFR w/attached garage	2003 IRC	Plan:3042		2005
New	2 story sfr w/attached gargage				2005
New	Approved Basic 04-115827BP	2 story SFR w/attached garage	2003 IRC	Plan:2968	2005
New	Approved basic 05-118084 BP	2003 IRC	Plan# 3048	2-story sfr w/attached garage	2005
New	Approved Basic 04-115827BP	2 story SFR w/attached garage	2003 IRC	Plan:2968	2005
New	Approved Basic 04-115826BP	2 story SFR w/attached garage	2003 IRC	Plan:2783	2005
New	Approved Basic 05-118084 BP	2003 IRC	Plan# 3048	2-story sfr w/attached garage	2005
New	Approved Basic 04-116048-BP	2 story SFR w/attached 3 car garage	2003 IRC	Bldr s. Plan	2005
New	Approved Basic 04-115826BP	2 story SFR w/attached garage	2003 IRC	Plan:2783	2005
New	Approved Basic 04-115827BP	2 story SFR w/attached garage	2003 IRC	Plan:2968	2005
New	Approved Basic 04-116048-BP	2 story SFR w/attached 3 car garage	2003 IRC	Bldr s. Plan	2005
New	Two-story SFR with attached garage -	2003 IRC			2005

Accessory Dwelling Units

Index # - File Name: 1.0022 - Single Family Dwellings Data\_Snohomish County.pdf

New	Approved basic 05-119652 BP	2003 IRC	Plan# 3066	2-story SFR w/attached gara	2005
New	Approved Basic 05-101013BP		2003 IRC	Plan: 2722	2005
New	2 story sfr w/attached garage				2005
New	Approved Basic 04-115831 BP	2 story SFR w/attached garage	2003 IRC	Plan:2797	2005
New	Approved Basic 04-115824BP	2 story SFR w/attached garage	2003 IRC	Plan:2611	2005
New	Approved Basic 04-115826BP	2 story SFR w/attached garage	2003 IRC	Plan:2783	2005
New	Two-story SFR with attached garage -	2003 IRC			2005
New	Approved Basic 04-115826BP	2 story SFR w/attached garage	2003 IRC	Plan:2783	2005
New	Approved Basic 04-116048-BP	2 story SFR w/attached 3 car garage	2003 IRC	Bldr s. Plar	2005
New	Two-story SFR with attached garage -	2003 IRC	Plan: 3874		2005
New	Approved Basic 04-115827BP	2 story SFR w/attached garage	2003 IRC	Plan:2968	2005
New	Approved basic 05-119652 BP	2003 IRC	Plan# 3066	2-story SFR w/attached gara	2005
New	Two Story SFR with Attached Garage	2003 IRC			2005
New	Rambler style SFR w/garage				2005
New	Approved Basic 04-115831 BP	2 story SFR w/attached garage	2003 IRC	Plan:2797	2005
New	Approved Basic 04-115827BP	2 story SFR w/attached garage	2003 IRC	Plan:2968	2005
New	Two Story SFR with Finished Basement and Attached Garage				2005
New	Two Story SFR with Attached Garage and 1080 SF Semi Finished Basement	2003 IRC			2005
New	Two story SFR with attached Garage				2005
New	1400 sq ft Rambler with finished Basement				2005
New	Two Story SFR with Attached Garage				2005
New	2-Story SFR w/attached garage.				2005
New	1767 sq ft Rambler with attached Garage				2005
New	Approved basic 05-125476 BP	2003 IRC	Plan# 3240	2-story sfr w/attached gara	2005
New	Approved basic 05-125476 BP	2003 IRC	Plan# 3240	2-story sfr w/attached gara	2005
New	1674 sq ft rambler with attached garage				2005
New	Two-story SFR				2005
New	Convert semi-finished to finished				2005
New	Two Story SFR - 1997 UBC				2005
New	Two-story SFR				2005
New	Two-story sfr with garage				2005
New	Two story SFR with attached two story garage				2005
New	Two-story sfr with attached garage				2005
New	Two Story SFR with 637 SF Semi-Finished Basement				2005
New	2-story sfr w/attached garage				2005
New	2- story sfr w/attached garage				2005
New	2 story SFR w/ atcthd 3 car garage				2005
New	1997 Marlette 40 x 62				2005
New	Approved Basic 04-115827BP	2 story SFR w/attached garage	2003 IRC	Plan:2968	2005
New	Approved Basic 04-115827BP	2 story SFR w/attached garage	2003 IRC	Plan:2968	2005
New	Rambler Style SFR - 1997 UBC				2005
New	Approved basic 05-119649 BP	2003IRC	Plan # 2588	2 story sfr w/attached garag	2005
New	Approved Basic 04-115827BP	2 story SFR w/attached garage	2003 IRC	Plan:2968	2005
New	2 story SFR w/ atcthd 2 car garage				2005
New	2 story SFR w/attached garage	2003 IRC			2005
New	2-Story SFR w/attached garage.				2005
New	Two Story SFR with 1254 Sq Ft Unfinished Basement and Attached Garage				2005

Accessory Dwelling Units

Index # - File Name: 1.0022 - Single Family Dwellings Data\_Snohomish County.pdf

New	Approved Basic #03-105122 BP	Plan: A1a	Two-story SFR - 1997 UBC	2005
New	Approved Basic #03-105122 BP	Plan: A1a	Two-story SFR - 1997 UBC	2005
New	Approved Basic 03-102960 BP	Plan: D1a	Two-story SFR - 1997UBC	2005
New	Approved Basic #04-118537 BP	2-story w/garage	2003 IRC Plan: C	2005
New	Approved Basic #03-105121 BP	Plan: B2a	Two-story SFR - 1997 UBC	2005
New	Approved Basic #03-105123 BP	Plan: B3a	Two-story SFR - 1997 UBC	2005
New	Approved Basic #03-105123 BP	Plan: B3a	Two-story SFR - 1997 UBC	2005
New	2 story story duplex w/ 2 car garage	NEEDS GRADING FEES TO BE COLLECTED PRIOR TO ISSUAN		2005
New	Two Story SFR with Attached Garage	2003 IRC		2005
New	Two Story SFR - 1997 UBC	Plan B3A		2005
New	Approved Basic 05- 117124BP	2003 IRC	Plan:1870 2 story SFR w/attached gar	2005
New	Approved Basic #04-118537 BP	2-story w/garage	2003 IRC Plan: C	2005
New	Two-story SFR w/finished garage			2005
New	2-Story SFR over finished basement area w/attached garage.			2005
New	2 story SFR w/attached garage	2003 IRC		2005
New	Rambler style w/garage			2005
New	Rambler w/attached garage			2005
New	1826 sf rambler with attached 2-car garage -	2003 IRC		2005
New	Two story SFR with attached Garage			2005
New	2 story sfr w/attached garage			2005
New	2 story single family with unfinished basement and attached garage			2005
New	Duplex			2005
New	Two story SFR with attached Garage			2005
New	2-Story SFR w/attached garage			2005
New	2005 - 68 x 40 Fleetwood Mobile home.			2005
New	Approved basic 05-120274 BP	2003 IRC	Plan # 1625 2-story sfr w/attached gara	2005
New	2-story SFR w/garage & covered deck			2005
New	2-story SFR w/garage & covered deck			2005
New	2-story w/garage & covered deck/porch			2005
New	2-story w/unfinished basement & garage			2005
New	Two Story SFR with attached garage			2005
New	Two story SFR with attached Garage			2005
New	Two story SFR with attached Garage			2005
New	STOP WORK 10/7/05 AT REQUEST OF SHD. DO NOT RESUME UNTIL RESOLVED (see SHD ltr in r			2005
New	2 story w/ basement w/ attchd. 3-car garage			2005
New	2-story w/ attchd. 3-car garage			2005
New	Two story SFR with attached Garage			2005
New	Two-story sfr with attached garage			2005
New	2 story SFR w/attached garage	2003 IRC	Plan:	2005
New	Approved Basic 04-117597BP	2 story SFR w/attached garage	2003 IRC Plan:3575	2005
New	24 x 34 1977 Guerdon-Camelot Mobile Home			2005
New	Approved Basic 05-100046BP	2003 IRC	Plan:2811 A & C 2 story SFR w/attached gara	2005
New	Approved Basic 04-120594BP	2 story SFR w/attached garage	2003 IRC Plan:2011A	2005
New	Approved Basic 05-125222BP	2003 IRC	2 story SFR w/attached garage Plan:2313C	2005
New	Approved Basic 05-124091BP	2003 IRC	2 story SFR w/attached garage Plan:2723B	2005
New	Approved Basic 04-116513BP		Plan: 2421 A & B Two-story SFR with atta	2005
New	Approved Basic 05-100046BP	2003 IRC	Plan:2811 A & C 2 story SFR w/attached gara	2005

Accessory Dwelling Units

Index # - File Name: 1.0022 - Single Family Dwellings Data\_Snohomish County.pdf

New	Approved	Basic 05-125224BP	2003 IRC	2 story SFR w/attached garage	Plan:2413A	2005
New	Approved	Basic 05-126115BP	2003 IRC	2 story SFR w/attached garage	Plan:2433A	2005
New	Approved	Basic 04-116503BP		Plan: 1811B Two-story SFR with attached		2005
New	Approved	Basic 05-128467BP	2003 IRC	2 story SFR w/attached garage	Plan:2831B	2005
New	Approved	Basic 05-118924BP	2003 IRC	2 story SFR w/attached garage	Plan:2621C	2005
New	Approved	Basic 04-117263BP	2003 IRC	2 story SFR w/attached garage	Plan:3131B	2005
New	Approved	Basic #04-100360 BP		Plan: 2221 B Two story SFR w/attached garage	19	2005
New	Approved	Basic 05-125226BP	2003 IRC	2 story SFR w/attached garage	Plan:3241B & C	2005
New	Approved	basic 05-125532BP	2003 IRC	Plan# 2811 B 2-story sfr w/attached garage		2005
New	Approved	Basic 05-121678BP	2003 IRC	2 story SFR w/attached garage	Plan:241	2005
New	Approved	Basic 04-119214BP	2003 IRC	2 story SFR w/attached garage	Plan:2831 A & C	2005
New	Approved	Basic 04-116493BP		Plan: 2421 C Two-story SFR with attached		2005
New	Approved	Basic 04-116513BP		Plan: 2421 A & B Two-story SFR with atta		2005
New	Approved	Basic 05-100046BP	2003 IRC	Plan:2811A & C 2 story SFR w/attac		2005
New	Approved	Basic 04-121383BP	2003 IRC	2 story SFR w/attached garage	Plan:3121B	2005
New	Approved	Basic 05-117086BP	2003IRC		Plan:1711C	2005
New	Approved	Basic #05-127682BP	2003 IRC	Plan: 2641 C 2 Story SFR w/attached gara		2005
New	Approved	Basic 05-101426BP	2003 IRC	Plan:2721A		2005
New	Approved	Basic 05-100758BP	2003 IRC	Plan:2021A		2005
New	Approved	Basic 04-116503BP		Plan: 1811B Two-story SFR with attached		2005
New	Approved	Basic 04-121383BP	2003 IRC	2 story SFR w/attached garage	Plan:3121B	2005
New	Approved	Basic 05-117923BP	2003 IRC	Plan:2585A 2 story SFR w/attached gara		2005
New	Approved	Basic 04-116493BP		Plan: 2421 C Two-story SFR with attached		2005
New	Approved	Basic 04-116509BP		Plan: 1821B Two-story SFR with attached		2005
New	Approved	Basic 04-120594BP	2003 IRC	2 story SFR w/attached garage	Plan:2011A	2005
New	Approved	Basic 04-116509BP		Plan: 1821B Two-story SFR with attached		2005
New	Approved	Basic 04-116493BP		Plan: 2421 C Two-story SFR with attached		2005
New	Approved	Basic 04-116513BP		Plan: 2421 A & B Two-story SFR with atta		2005
New	Approved	Basic 04-116493BP		Plan: 2421 C Two-story SFR with attached		2005
New	Approved	Basic 04-116513BP		Plan: 2421 A & B Two-story SFR with atta		2005
New	Approved	Basic 05-121682BP	2003 IRC	2 story SFR w/attached garage	Plan:2141	2005
New	Approved	Basic 04-116513BP		Plan: 2421 A & B Two-story SFR with atta		2005
New	Approved	Basic 04-116493BP		Plan: 2421 C Two-story SFR with attached		2005
New	Approved	Basic 05-122910BP	2003 IRC	2 story SFR w/attached garage	Plan:2651	2005
New	Approved	Basic 04-116493BP		Plan: 2421 C Two-story SFR with attached		2005
New	Approved	Basic 04-117442BP	2003 IRC	2 story SFR w/attached garage	Plan:1611C	2005
New	Approved	Basic 05-117988BP	2003 IRC	Plan:1811C		2005
New	Approved	Basic 05-118265BP	2003 IRC	2 story SFR w/attached garage	Plan:1611A	2005
New	Approved	Basic 04-116509BP		Plan: 1821B Two-story SFR with attached		2005
New	Approved	Basic 04-116493BP		Plan: 2421 C Two-story SFR with attached		2005
New	Approved	Basic 05-123185BP	2003 IRC	2 story SFR w/attached garage	Plan:2611C	2005
New		2 story SFR with attached garage				2005
New		2-story w/garage				2005
New	Approved	Basic 04-119795BP	2003 IRC	2 story SFR w/attached garage	Plan:1821C	2005
New		rambler style w/garage				2005
New		2 story SFR w/attached garage	2003 IRC	Plan:4012-A-LX		2005
New	Approved	Basic 05-124091BP	2003 IRC	2 story SFR w/attached garage	Plan:2723B	2005

Accessory Dwelling Units

Index # - File Name: 1.0022 - Single Family Dwellings Data\_Snohomish County.pdf

New	Approved Basic 04-116493BP		Plan: 2421 C	Two-story SFR with attached	2005
New	Approved Basic 04-116513BP		Plan: 2421 A & B	Two-story SFR with atta	2005
New	Approved Basic 05-123440BP	2003 IRC		2 story SFR w/attached garage	2005
New	2729 sq ft Rambler with Attached Garage				2005
New	One-story sfr with attached garage				2005
New	Approved Basic 05-123194BP	2003 IRC		1 story SFR w/storage above garage	2005
New	2 story SFR with unfinished basement & attached Carport				2005
New	Approved Basic 04-112756BP	2003 IRC	Plan: Mt Rainier	2 story SFR w/attached garage	2005
New	Approved Basic 04-120030BP	2003 IRC	Plan :The Chandler	1 Story SFR w/semifinished	2005
New	Two-story SFR with 3-car garage			*original permit issued under parent tax #280632-001-006-00'	2005
New	Two-story SFR w/unfinished basement		Builder s Plan: 94700		2005
New	Approved Basic #05-116442BP	2003 IRC	Plan C-GN	2 story SFR w/attached garage	2005
New	Approved Basic #05-116442BP	2003 IRC	Plan: C	2 story SFR w/attached garage	2005
New	Approved Basic 03-102960 BP		Plan: D1a	Two-story SFR - 1997UBC	2005
New	Approved Basic 05- 117124BP	2003 IRC	Plan:1870	2 story SFR w/attached gar	2005
New	Approved Basic #04-118537 BP	2-story w/garage	2003 IRC	Plan: C	2005
New	Approved Basic 05- 117124BP	2003 IRC	Plan:1870	2 story SFR w/attached gar	2005
New	Approved Basic #04-118537 BP	2-story w/garage	2003 IRC	Plan: C	2005
New	Approved Basic 05- 117124BP	2003 IRC	Plan:1870	2 story SFR w/attached gar	2005
New	Approved Basic #04-118537 BP	2-story w/garage	2003 IRC	Plan: C	2005
New	Approved Basic 05- 117124BP	2003 IRC	Plan:1870	2 story SFR w/attached gar	2005
New	Approved basic 05-102045 BP	2003 IRC	Plan: B3a	2-story sfr w/attached garage	2005
New	Approved Basic #05-116442BP	2003 IRC	Plan:C-GN	2 story SFR w/attached garage	2005
New	Approved Basic #03-105123 BP		Plan: B3a	Two-story SFR - 1997 UBC	2005
New	Approved Basic #03-105121 BP		Plan: B2a	Two-story SFR - 1997 UBC	2005
New	Approved Basic #03-105123 BP		Plan: B3a	Two-story SFR - 1997 UBC	2005
New	Approved Basic #03-105121 BP		Plan: B2a	Two-story SFR - 1997 UBC	2005
New	Approved Basic #03-105123 BP		Plan: B3a	Two-story SFR - 1997 UBC	2005
New	Approved Basic #03-105121 BP		Plan: B2a	Two-story SFR - 1997 UBC	2005
New	Approved basic 05-102045 BP	2003 IRC	Plan: B3a	2-story sfr w/attached garage	2005
New	Approved Basic #03-105121 BP		Plan: B2a	Two-story SFR - 1997 UBC	2005
New	Approved Basic #03-105123 BP		Plan: B3a	Two-story SFR - 1997 UBC	2005
New	Approved Basic #03-105119 BP		Plan: B1b	Two-story SFR - 1997 UBC	2005
New	Approved Basic #03-105121 BP		Plan: B2a	Two-story SFR - 1997 UBC	2005
New	Approved Basic #03-105123 BP		Plan: B3a	Two-story SFR - 1997 UBC	2005
New	Approved Basic #05-116442BP	2003 IRC	Plan: C-GN	2 story SFR w/attached garage	2005
New	Approved Basic 04-112108-BP			Rambler w/attached garage	2005
New	Approved Basic 04-112103BP	2 story SFR w/attached garage	2003 IRC	Plan:Glacier Peak	2005
New	Approved Basic 04-112108-BP			Rambler w/attached garage	2005
New	Approved Basic 05-119760BP	2003 IRC		2 story SFR w/attached garage	2005
New	Approved Basic 04-112102-BP			Mid-Entry w/finished basement	2005
New	Approved Basic 04-112108-BP			Rambler w/attached garage	2005
New	Approved Basic 04-112103BP	2 story SFR w/attached garage	2003 IRC	Plan:Glacier Peak	2005
New	Approved Basic 04-112108-BP			Rambler w/attached garage	2005
New	Approved Basic 04-121395 BP			2-story w/attached garage	2005
New	Approved Basic 04-112108-BP			Rambler w/attached garage	2005
New	Approved Basic 04-112103BP	2 story SFR w/attached garage	2003 IRC	Plan:Glacier Peak	2005

Accessory Dwelling Units

Index # - File Name: 1.0022 - Single Family Dwellings Data\_Snohomish County.pdf

New	Approved Basic 04-112108-BP	Rambler w/attached garage	2003-IRC	2005
New	Approved Basic 04-1120161 BP	Plan: Mt. Index 2 story sfr w/attached 3-ca		2005
New	Approved Basic 04-112108-BP	Rambler w/attached garage	2003-IRC	2005
New	Approved Basic 04-112108-BP	Rambler w/attached garage	2003-IRC	2005
New	Approved Basic 05-119760BP	2003 IRC 2 story SFR w/attached garage	Plan: Mt Adams	2005
New	Approved Basic 04-112107BP	Bldr. Plan: Mt Rainer A	2003 - IBC 2 story SFF	2005
New	Approved Basic 04-1120161 BP	Plan: Mt. Index 2 story sfr w/attached 3-ca		2005
New	Approved Basic 04-112103BP	2 story SFR w/attached garage	2003 IRC Plan: Glacier Peak	2005
New	Approved Basic 04-112108-BP	Rambler w/attached garage	2003-IRC	2005
New	Approved Basic 04-112107BP	2 story SFR w/attached car	2003 IRC Plan	2005
New	Approved Basic 04-112108-BP	Rambler w/attached garage	2003-IRC	2005
New	Approved Basic 04-112103BP	2 story SFR w/attached garage	2003 IRC Plan: Glacier Peak	2005
New	Approved Basic 04-112108-BP	Rambler w/attached garage	2003-IRC	2005
New	Approved Basic 04-1120161 BP	Plan: Mt. Index 2 story sfr w/attached 3-ca		2005
New	Approved Basic 04-116008BP	2 story SFR w/attached garage	2003 IRC Plan: 2160	2005
New	Approved Basic 04-116008BP	2 story SFR w/attached garage	2003 IRC Plan: 2160	2005
New	Approved Basic 04-1125956BP	2 story SFR w/attached garage	2003 IRC Plan: 2054	2005
New	Approved Basic 04-118154BP	2 story SFR w/attached garage	2003 IRC Bldr s Plan #B1:	2005
New	Two-story SFR-split level - 1997 UBC	New RSP recieved 4/20/06, for MO. mn		2005
New	Approved Basic 05-120271 BP	2003 IRC Plan #2160 - B	2-story sfr w/attached gar	2005
New	Approved Basic 04-116008BP	2 story SFR w/attached garage	2003 IRC Plan: 2160	2005
New	Approved Basic 04-116008BP	2 story SFR w/attached garage	2003 IRC Plan: 2160	2005
New	Approved Basic 04-118699BP	2 story SFR w/attached garage	2003 IRC Plan: B127B	2005
New	Approved Basic 04-118154BP	2 story SFR w/attached garage	2003 IRC Bldr s Plan #B1:	2005
New	Approved Basic 04-118907BP	2 story SFR w/attached garage	2003 IRC Plan: G531-A	2005
New	Approved basic 05-124145 BP	2003 IRC Plan # B.134.B	2-story sfr w/attached g	2005
New	Approved Basic 04-118154BP	2 story SFR w/attached garage	2003 IRC Bldr s Plan #B1:	2005
New	Approved Basic 04-118701BP	2 story SFR w/attached garage	2003 IRC Plan: B127C	2005
New	Approved Basic 04-118907BP	2 story SFR w/attached garage	2003 IRC Plan: G531-A	2005
New	Approved Basic 04-118156BP	2 story SFR w/attached garage	2003 IRC Bldr s. Plan# B1	2005
New	Approved Basic 05-122717 BP	2003 IRC Plan# B 135 B		2005
New	Approved Basic 04-118154BP	2 story SFR w/attached garage	2003 IRC Bldr s Plan #B1:	2005
New	Approved basic 05-124149 BP	2003 IRC Plan# B 135 A	2-story sfr w/attached g	2005
New	Approved Basic 04-118154BP	2 story SFR w/attached garage	2003 IRC Bldr s Plan #B1:	2005
New	Approved Basic 04-118699BP	2 story SFR w/attached garage	2003 IRC Plan: B127B	2005
New	Approved Basic 04-118156BP	2 story SFR w/attached garage	2003 IRC Bldr s. Plan# B1	2005
New	Approved basic 05-123494 BP	2003 IRC Plan B-134-A	2-story sfr w/attached garag	2005
New	Approved basic 05-122717 BP	2003 IRC 2 story SFR w/attached garage	Plan# B 135	2005
New	Approved Basic 04-118154BP	2 story SFR w/attached garage	2003 IRC Bldr s Plan #B1:	2005
New	Approved basic 05-124145 BP	2003 IRC Plan # B.134.B	2-story sfr w/attached g	2005
New	Approved Basic 04-118154BP	2 story SFR w/attached garage	2003 IRC Bldr s Plan #B1:	2005
New	Approved basic 05-124149 BP	2003 IRC Plan# B 135 A	2-story sfr w/attached g	2005
New	Approved Basic 04-118156BP	2 story SFR w/attached garage	2003 IRC Bldr s. Plan# B1	2005
New	Approved basic 05-123494 BP	2003 IRC Plan B-134-A	2-story sfr w/attached garag	2005
New	Approved basic 05-122717 BP	2003 IRC 2 story SFR w/attached garage	Plan# B 135	2005
New	Approved Basic 04-118156BP	2 story SFR w/attached garage	2003 IRC Bldr s. Plan# B1	2005
New	Approved Basic 04-118698BP	2 story SFR w/attached garage	2003 IRC Plan: B127A	2005



Accessory Dwelling Units

Index # - File Name: 1.0022 - Single Family Dwellings Data\_Snohomish County.pdf

New	Approved Basic 04-118154BP	2 story SFR w/attached garage	2003 IRC	Bldr s Plan #B1:	2005
New		2-Story SFR over daylight basement			2005
New	Approved Basic 04-116860BP	2 stroy SFR w/attached garage	2003 IRC	Plan:1931B	2005
New	Approved Basic 05-100390BP	2 stroy SFR w/attached garage	2003 IRC	Plan:1941A	2005
New	Approved Basic 04-118667BP	2 story SFR w/attached garage	2003 IRC	Plan:1172 ORO	2005
New	Approved Basic 04-113593BP		Plan: 1760 Flat	Two-story SFR - 2003 IRC	2005
New	Approved Basic 04-113750BP		Plan 1174	Two-story SFR 2003 IRC	2005
New	Approved Basic 04-113593BP		Plan: 1760 Flat	Two-story SFR - 2003 IRC	2005
New	Approved Basic 04-113750BP		Plan 1174	Two-story SFR 2003 IRC	2005
New	Approved Basic 04-113593BP		Plan: 1760 Flat	Two-story SFR - 2003 IRC	2005
New	Approved Basic 04-113587BP		Plan: 1176 Basement 1	Two-story SFR with day	2005
New	Approved Basic 04-112412BP	2 story SFR w/finished basement & attached garage	2003 IRC		2005
New	Approved Basic 04-113587BP		Plan: 1176 Basement 1	Two-story SFR with day	2005
New	Approved Basic 04-112412BP	2 story SFR w/finished basement & attached garage	2003 IRC		2005
New	Approved Basic 04-112412BP	2 story SFR w/finished basement & attached garage	2003 IRC		2005
New	Approved Basic 04-113587BP		Plan: 1176 Basement 1	Two-story SFR with day	2005
New	Approved Basic 04-113587BP		Plan: 1176 Basement 1	Two-story SFR with day	2005
New	Approved Basic 04-112412BP	2 story SFR w/finished basement & attached garage	2003 IRC		2005
New	Approved Basic 04-113587BP		Plan: 1176 Basement 1	Two-story SFR with day	2005
New	Approved Basic 04-112412BP	2 story SFR w/finished basement & attached garage	2003 IRC		2005
New	Approved Basic 04-113594BP	This structure must be built in a 32 or more height zone	2 stor		2005
New	Approved Basic 04-113594BP	This structure must be built in a 32 or more height zone	2 stor		2005
New	Approved Basic 04-113546BP	Structure must be built in 34 height or more zone	2 story		2005
New	Approved Basic 04-113594BP	This structure must be built in a 32 or more height zone	2 stor		2005
New	Approved Basic 04-113546BP	Structure must be built in 34 height or more zone	2 story		2005
New	Approved Basic 04-113594BP	This structure must be built in a 32 or more height zone	2 stor		2005
New	Approved Basic 04-113546BP	Structure must be built in 34 height or more zone	2 story		2005
New		One-story sfr with garage.			2005
New		Two-story sfr with attached garage			2005
New		Rambler style w/garage			2005
New	Approved Basic 05- 1000527BP				2005
New	Approved Basic 04-117012BP	2 story SFR w/attached garage	2003 IRC	Plan:2111A	2005
New	Approved Basic 05-116656BP		2003 IRC	Plan:2741A	2005
New	Approved Basic 04-116853BP	2 Stroy SFR w/attached garage	2003 IRC	Plan:2721B	2005
New	Approved Basic 05-117083BP		2003 IRC	Plan:2021C	2005
New	Approved Basic 04-116493BP		Plan: 2421 C	Two-story SFR with attached	2005
New	Approved Basic 05-120763BP		2003 IRC	2 story SFR w/attached garage	Plan:2211 2005
New	Approved Basic 04-116853BP	2 Stroy SFR w/attached garage	2003 IRC	Plan:2721B	2005
New	Approved Basic 04-116513BP		Plan: 2421 A & B	Two-story SFR with atta	2005
New	Approved Basic 04-116509BP		Plan: 1821B	Two-story SFR with attached	2005
New	Approved Basic 04-121554BP	2 story SFR w/attached garage	2003 IRC	Plan:1941B	2005
New	Approved Basic 04-116853BP	2 Stroy SFR w/attached garage	2003 IRC	Plan:2721B	2005
New	Approved Basic 05-101187BP		2003 IRC	Plan:1721A	2005
New	Approved Basic 05-117923BP		2003 IRC	Plan:2585A	2 story SFR w/attached gar: 2005
New	Approved Basic 05-121682BP		2003 IRC	2 story SFR w/attached garage	Plan:2141A 2005

Accessory Dwelling Units

Index # - File Name: 1.0022 - Single Family Dwellings Data\_Snohomish County.pdf

New	Approved	Basic 05-117341BP	2003 IRC	Plan:1631C	2 story SFR w/attached garage	2005
New	Approved	Basic 05-118601BP	2003 IRC		2 story SFR w/attached garage Plan:1731E	2005
New	Approved	Basic 05-100758BP		2003 IRC	Plan:2021A	2005
New	Approved	Basic 05-100962BP		2003 IRC	Plan:2841B	2005
New	Approved	Basic 05-101187BP		2003 IRC	Plan:1721A	2005
New	Approved	Basic 05-116050BP		2003 IRC	Plan:2031C	2005
New	Approved	Basic 05-118591BP	2003 IRC		2 story SFR w/attached garage Plan:2011	2005
New	Approved	Basic 04-117251BP		2003 IRC	Plan :1621A	2005
New	Approved	Basic 05-118268BP	2003 IRC		2 story SFR w/attached garage Plan:2031B	2005
New	Approved	Basic 04-11744BP		2003 IRC	Plan:1821A	2005
New	Approved	Basic 05-117988BP		2003 IRC	Plan:1811C	2005
New	Approved	Basic 05-118609BP	2003 IRC		2 story SFR w/attached garage Plan:2231B	2005
New	Approved	Basic 05-117668BP	2003 IRC	Plan:1665A	2 story SFR w/attached ga	2005
New	Approved	Basic 05-119428BP	2003 IRC		2 story SFR w/attached garage Plan:1621C	2005
New	Approved	Basic 05-118265BP	2003 IRC		2 story SFR w/attached garage Pl	2005
New	Approved	Basic 05-100386BP	2003 IRC	Plan:1811A	2 story SFR w/attached garage	2005
New	Approved	Basic 04-119795BP		2003 IRC	Plan:1821C	2005
New	Approved	Basic 05-117923BP	2003 IRC	Plan:2585A	2 story SFR w/attached gara	2005
New	Approved	Basic 05-100758BP		2003 IRC	Plan:2021A	2005
New	Approved	Basic 04-118418BP		2003 IRC	Plan:2141C	2005
New	Approved	Basic 04-116853BP		2003 IRC	Plan:2721B	2005
New	Approved	Basic 05-118596BP	2003 IRC		2 story SFR w/attached garage Plan:2211B	2005
New	Approved	Basic 05-101426BP		2003 IRC	Plan:2721A	2005
New	Approved	Basic 05-119712BP	2003 IRC		2 story SFR w/attached garage Plan:1865A	2005
New	Approved	Basic 04-116513BP			Plan: 2421 A & B Two-story SFR with atta	2005
New	Approved	Basic 04-116493BP			Plan: 2421 C Two-story SFR with attached	2005
New	Approved	Basic 05-117665BP	2003 IRC	Plan:2295C	2 story SFR w/attached gar	2005
New	Approved	Basic 05-100386BP	2003 IRC	Plan:1811A	2 story SFR w/attached garage	2005
New	Approved	Basic 04-116493BP			Plan: 2421 C Two-story SFR with attached	2005
New	Approved	Basic 05-119426BP	2003 IRC		2 story SFR w/attached garage Plan:2441B	2005
New	Approved	Basic 05-118924BP	2003 IRC		2 story SFR w/attached garage Plan:2621C	2005
New	Approved	Basic 04-116503BP			Plan: 1811B Two-story SFR with attached	2005
New	Approved	Basic 04-116513BP			Plan: 2421 A & B Two-story SFR with atta	2005
New	Approved	Basic 04-116493BP			Plan: 2421 C Two-story SFR with attached	2005
New	Approved	Basic 05-100756BP		2003 IRC	Plan:2295B	2005
New	Approved	Basic 04-116860BP		2003 IRC	Plan:1931B	2005
New	Approved	Basic 05-100394BP		2003 IRC	Plan:2271B 2 story SFR w/attached g	2005
New	Approved	Basic 04-119217BP		2003 IRC	Plan:1931A	2005
New	Approved	Basic 05- 101825BP		2003 IRC	Plan:2475A	2005
New	Approved	Basic 05- 101833BP		2003 IRC	Plan:1951A	2005
New	Approved	Basic 05-116349BP		2003 IRC	Plan:2271A	2005
New	Approved	Basic 05-118931BP	2003 IRC		2 story SFR w/attached garage Plan:2271C	2005
New	Approved	Basic 04-116503BP			Plan: 1811B Two-story SFR with attached	2005
New	Approved	basic 05-121454 BP	2003 IRC	Plan# 3111 C	2-story sfr w/attached garag	2005
New	Approved	Basic 04-116493BP			Plan: 2421 C Two-story SFR with attached	2005
New	Approved	Basic 04-116513BP			Plan: 2421 A & B Two-story SFR with atta	2005
New	Approved	basic 05-121453 BP	2003 IRC	Plan# 2565 C	2-story sfr w/attached garag	2005

Accessory Dwelling Units

Index # - File Name: 1.0022 - Single Family Dwellings Data\_Snohomish County.pdf

New	Approved Basic 05-120481BP	2003 IRC	2 story SFR w/attached garage	Plan:2131	2005
New	Approved Basic 05-100386BP	2003 IRC	2 story SFR w/attached garage	Plan:1811A	2005
New	Two-story sfr with attached garage				2005
New	Rambler w/ attchd 3 car garage				2005
New	2-story sfr w/attached garage				2005
New	Rambler style SFR w/garage				2005
New	One-story sfr with garage				2005
New	Two story SFR with attached Garage				2005
New	Approved Basic #04-116534BP		Plan:2274 Rambler style w/garage (2003 IRC)		2005
New	Approved Basic 04- 117174BP		Builders Plan #2952 2 Story w/attached		2005
New	2663 sq ft Rambler with attached Garage				2005
New	Two story SFR with attached garage				2005
New	Two story SFR with attached Garage				2005
New	Two story SFR with attached garage				2005
New	2-story SFR w/garage				2005
New	Two story SFR with attached Garage				2005
New	Rambler w/ daylight basement				2005
New	2 story SFR w/attached garage 2003 IRC				2005
New	Approved Basic 04-114495BP	Plan: 2328	Two-story SFR - 2003 IRC		2005
New	2 story single family residence with 2 car garage				2005
New	Approved Basic 04-114495BP	Plan: 2328	Two-story SFR - 2003 IRC		2005
New	Two-story SFR - 2003 IRC		Builders Plan: 2743		2005
New	Two story with basement garage		Plan: 1525		2005
New	2 story SFR w/attached garage				2005
New	2-Story SFR w/attached garage				2005
New	2-story SFR w/basement &				2005
New	One-story rambler sfr with garage				2005
New	Rambler w/daylight basement & attached garage				2005
New	Rambler w/ 3 car garage				2005
New	2-story SFR w/attached garage				2005
New	One-story sfr with garage				2005
New	Two-story SFR - 2003 IRC				2005
New	Two-story SFR - 2003 IRC				2005
New	Daylight Basement style SFR w/attached 3-car garage.				2005
New	4 bedroom Rambler w/ attchd. 4 car garage				2005
New	Two story SFR with attached garage				2005
New	Two story SFR with attached Garage				2005
New	2-Story SFR w/attached garage				2005
New	4 bedroom two story SFR w/ attchd. 3 car garage				2005
New	Two-story sfr with garage				2005
New	Two-story sfr with garage				2005
New	Two-story sfr with garage				2005
New	Two Story SFR with Attached Garage				2005
New	Daylight Basement Rambler (over unfinished basement) w/attached garage.				2005
New	2 story sfr w/attached garage				2005
New	2 story SFR w/finished basement & attached garage		2003 IRC		2005
New	One-story sfr with daylight basement and garage				2005

Accessory Dwelling Units

Index # - File Name: 1.0022 - Single Family Dwellings Data\_Snohomish County.pdf

New	2 - story SFR semi finished basement w/attached garage				2005
New	2 - story sfr w/attached garage				2005
New	2 story single family residence with 3 car garage				2005
New	Rambler style single family residence				2005
New	Approved basic #05-117623	2 Story SFR with Attached Garage	2003 IRC		2005
New	2 story SFR SFR w/attached garage	2003 IRC	Plan: Edgemont		2005
New	Two story SFR with attached Garage				2005
New	Approved basic #05-117623	2 Story SFR with Attached Garage	2003 IRC		2005
New	Approved Basic 04-121278BP	SFR w/attached garage	2003 IRC	Plan:2846-B	2005
New	Approved basic 04-121279 BP	Rambler style w/garage	2003 IRC	Plan:2	2005
New	One-story SFR - 2003 IRC			Builders Plan:	2005
New	2 - story sfr w/attached garage				2005
New	Approved Basic 04-119040BP		Plan: 5350	Two-story SFR with attach	2005
New	Approved Basic 04-119040BP		Plan: 5350	Two-story SFR with attach	2005
New	Approved Basic 04-119040BP		Plan: 5350	Two-story SFR with attach	2005
New	Approved Basic 05-126401 BP	2003 IRC	Plan#6280-ECI	2-story SFR w/attached gara	2005
New	Approved basic 05-126401BP	2003 IRC	Plan#6280-ECI	2-story SFR w/attached gara	2005
New	Approved 05-121648 BP	2003 IRC	Plan# G-540-A	2-story sfr w/attached garage	2005
New	Approved Basic 04-117382BP		Plan B.125.B	Two Story SF	2005
New	Approved basic 05-123494 BP	2003 IRC	Plan B-134-A	2-story sfr w/attached garag	2005
New	Approved Basic 04-117862BP		Plan: G523-A	Two-story SFR with attached	2005
New	Approved Basic 04-117862BP		Plan: G523-A	Two-story SFR with attached	2005
New	Approved Basic 04-117566BP		Plan: G522-C	Two-story SFR with attached	2005
New	Approved Basic 04-117864BP		Plan: G523-B	Two-story SFR with attached	2005
New	Approved Basic 04-116879BP		Plan: G524-A	Two-story SFR with attached	2005
New	Approved Basic 04-117565BP		Plan: G522-B	Two-story SFR with attached	2005
New	Approved Basic 04-117565BP		Plan: G522-B	Two-story SFR with attached	2005
New	Approved Basic 04-117385BP		Plan B.125.A	Two Story SFR with Attachi	2005
New	2-story sfr w/attached garage				2005
New	Approved Basic 04-117862BP		Plan: G523-A	Two-story SFR with attached	2005
New	Approved Basic 04-117565BP		Plan: G522-B	Two-story SFR with attached	2005
New	Approved Basic 04-116881BP		Plan: G524-C	Two-story SFR with attached	2005
New	Approved Basic 04-116879BP		Plan: G524-A	Two-story SFR with attached	2005
New	Approved Basic 04-117565BP		Plan: G522-B	Two-story SFR with attached	2005
New	Approved Basic 04-117385BP		Plan B.125.A	Two Story SFR with Attachi	2005
New	Approved Basic 04-117565BP		Plan: G522-B	Two-story SFR with attached	2005
New	Approved Basic 04-116879BP		Plan: G524-A	Two-story SFR with attached	2005
New	Approved Basic 04-116879BP		Plan: G524-A	Two-story SFR with attached	2005
New	Approved Basic 04-117562BP		Plan: G522-A	Two-story SFR with attached	2005
New	Approved Basic 04-116881BP		Plan: G524-C	Two-story SFR with attached	2005
New	Rambler w/ Unfinished daylight basement & 3-car attached Garage				2005
New	Approved Basic 04-117022BP	2 story SFR w/attached garage	2003 IRC	Plan:2217 w/lof	2005
New	Approved Basic 04-117020BP	2 story SFR w/attached garage	2003 IRC	Plan:2370 (VE)	2005
New	Two story SFR with attached Garage				2005
New	2-story SFR w/garage				2005
New	2 story single family residence				2005
New	2-story SFR w/garage				2005

Accessory Dwelling Units

Index # - File Name: 1.0022 - Single Family Dwellings Data\_Snohomish County.pdf

New	Two story sfr with attached 2-car garage				2005
New	2 story single family with 2 car garage				2005
New	2 story single family with attached garage				2005
New	2 story Single Family Residence with 3 Car Garage				2005
New	Approved Basic 05-100867 BP			Builders Plan: MU3DB-3170	2005
New	2 story SFR w/attached garage	2003 IRC			2005
New	2 stroy SFR w/attached garage	2003 IRC			2005
New	2 story SFR w/attached garage				2005
New	2 story SFR w/attached garage	2003 IRC			2005
New	Approved Basic # 05-126861BP	2003 IRC	SFR w/finished basement	Plan: R3DB-42	2005
New	Approved Basic #05-126865BP		2003 IRC	Plan: MV3-3568 AB Two	2005
New	Approved Basic #05-126865BP		2003 IRC	Plan: MV3-3568 AB Two	2005
New	Approved Basic 05-126861 BP	2003 IRC	SFR with finished Basement	Plan: R3DB-42	2005
New	2 story w/ 3 car RV garage				2005
New	Two-story SFR with attached garage -2003 IRC		Plan: Adams		2005
New	2-story SFR w/garage				2005
New	2 story single family residence with attached 3 car garage				2005
New	Two story SFR with attached Garage				2005
New	Approved Basic 05-100867 BP	2003 IRC		Plan: MU3DB-3170 Two-stor	2005
New	Two-story sfr with attached garage				2005
New	Approved Basic 05-101086BP	2003 IRC	Plan:R4T-2533A		2005
New	Approved Basic 05-100867 BP	2003 IRC		Plan: MU3DB-3170 Two-stor	2005
New	2-story SFR w/garage				2005
New	Two story SFR with attached Garage				2005
New	Approved Basic 05-101086BP	2003 IRC	Plan:R4T-2533A		2005
New	2-story w/garage				2005
New	Two Story SFR with 932 SF Finished Basement and Attached Garage		2003 IRC		2005
New	Two-story SFR - 2003 IRC			Builder s Plan: MU#-3105	2005
New	2-story w/garage				2005
New	Approved Basic 04-109988BP	2 story SFR w/attached garage	1997 UBC	Plan:#2165B	2005
New	2-story sfr w/attached garage				2005
New	2 story SFR w/attached garage	2003 IRC			2005
New	2 story SFR w/attached garage	2003 IRC			2005
New	2 story single family residence				2005
New	Approved Basic #04-113156 BP		Plan:2591	2-story w/attached garage 2	2005
New	Approved Basic 04-120862BP	2 story SFR w/attached garage	2003 IRC	Plan:2743-04 B	2005
New	Approved Basic 05-116434BP	2003IRC	Plan:Prairie Wind	38#snow load de	2005
New	Approved Basic 04-120862BP	2 story SFR w/attached garage	2003 IRC	Plan:2743-04 B	2005
New	Approved Basic 04-120862BP	2 story SFR w/attached garage	2003 IRC	Plan:2743-04 B	2005
New	Approved Basic 04-120862BP	2 story SFR w/attached garage	2003 IRC	Plan:2743-04 B	2005
New	2 story SFR w/attached garage	2003 IRC			2005
New	Approved Basic 05-116434 BP	2003 IRC	Plan: Prairie Wind	38# snow load de	2005
New	2 story SFR w/finished basement & attached garage	2003 IRC			2005
New	2 story SFR w/finished basement & attached garage		Plan:Pemberton w/finished Basement		2005
New	Two story SFR with attached Garage				2005
New	2 - story sfr w/attached garage				2005
New	Approved Basic #05-126865 BP	2003 IRC		Plan: MV3-3568 AB Two	2005

Accessory Dwelling Units

Index # - File Name: 1.0022 - Single Family Dwellings Data\_Snohomish County.pdf

New	2 story SFR w/attached garage				2005
New	Rambler style duplex w/ 2 Car Garages				2005
New	Two story SFR with attached Garage				2006
New	Two story SFR with attached Garage				2006
New	Approved Basic 05-116799BP	2003 IRC		Plan:2597 3 Car	2006
New	Approved Basic 06-103981BP	2003 IRC	2 story SFR w/attached garage	Plan:304	2006
New	Approved basic 06-126947 BP	2003 IRC	Plan# 3126	2-story sfr w/attached garage	2006
New	Approved basic 06-126631 BP	2003 IRC	Plan# 2278 Alt	2-story sfr w/attached gara	2006
New	Approved basic 06-126631 BP	2003 IRC	Plan# 2278 Alt	2-story sfr w/attached gara	2006
New	Approved Basic 05-116799BP	2003 IRC		Plan:2597 3 Car	2006
New	Approved Basic 04-118845BP	2 story SFR w/attached garage	2003 IRC	Plan:2294	2006
New	Approved Basic 05-127779BP	2003 IRC	2 story SFR w/attached garage	Plan:2278	2006
New	Approved Basic 05-118338BP	2003 IRC	Plan:1909BSM		2006
New	Approved Basic 06-102716BP	2003 IRC	2 story SFRw/finished bsmt & garage	Plan	2006
New	Approved Basic 04-120167BP	2 story SFR w/attached garage	2003 IRC	Plan:2597	2006
New	Approved Basic 05-128525 BP	2003 IRC	2 story SFR w/attached garage	Plan:245	2006
New	Approved Basic 04-120167BP	2 story SFR w/attached garage	2003 IRC	Plan:2597	2006
New	Approved Basic 05-128525 BP	2003 IRC	2 story SFR w/attached garage	Plan:245	2006
New	Approved Basic 06-103957BP	2003 IRC	2 sotry SFR w/attached garage	Plan:3049A	2006
New	Approved basic 06-127836 BP	2003 IRC	Plan# 3280	2-story sfr w/attached gara	2006
New	Approved basic 06-126947 BP	2003 IRC	Plan# 3126	2-story sfr w/attached garage	2006
New	Approved basic 06-126287 BP	2003 IRC	Plan# 3105	2-story sfr w/attached garage	2006
New	Approved basic 06-126947 BP	2003 IRC	Plan# 3126	2-story sfr w/attached garage	2006
New	Approved Basic 05-116799BP	2003 IRC		Plan:2597 3 Car	2006
New	Approved basic 06-127836 BP	2003 IRC	Plan# 3280	2-story sfr w/attached gara	2006
New	Approved basic 06-126947 BP	2003 IRC	Plan# 3126	2-story sfr w/attached garage	2006
New	Approved Basic 06-103981BP	2003 IRC	2 story SFR w/attached garage	Plan:304	2006
New	Approved Basic 05-116799BP	2003 IRC		Plan:2597 3 Car	2006
New	Approved Basic 06-103957BP	2003 IRC	2 sotry SFR w/attached garage	Plan:3049A	2006
New	Approved Basic 05-116166BP	2003 IRC	Plan: Tyhaka		2006
New	Approved basic 06-126947 BP	2003 IRC	Plan# 3126	2-story sfr w/attached garage	2006
New	Approved Basic 06-103957BP	2003 IRC	2 sotry SFR w/attached garage	Plan:3049A	2006
New	Approved basic 06-127836 BP	2003 IRC	Plan# 3280	2-story sfr w/attached gara	2006
New	1500 sq ft SFR				2006
New	2654 sq ft SFR				2006
New	2 story SFR w/ atcthd 3 car garage				2006
New	Approved Basic 04-118845BP	2 story SFR w/attached garage	2003 IRC	Plan:2294	2006
New	Approved basic 06-126631 BP	2003 IRC	Plan# 2278 Alt	2-story sfr w/attached gara	2006
New	Two story SFR with attached Garage				2006
New	EXPIRED WITHOUT COUNTY APPROVAL TO USE OR OCCUPY. SENT TO MICROFICHE 8/12/08 DM				2006
New	2166 sq. ft. SFR with 480 sq. ft. attached garage				2006
New	2166 sq. ft. SFR with 480 sq. ft. attached garage				2006
New	2-story w/garage				2006
New	3656 sq ft single family residence with 912 sq ft attached garage.				2006
New	1998 28 X 66 Double-wide MH				2006
New	2-story SFR w/garage				2006
New	30 x 40 two story SFR				2006

Accessory Dwelling Units

Index # - File Name: 1.0022 - Single Family Dwellings Data\_Snohomish County.pdf

New	SFR w/finished basement	2003 IRC			2006
New	2006 sq ft home with attached	724 sq ft garage.			2006
New	Approved Basic 06-125093-BP	2003 IRC	2 story SFRw/attached garage	Plan: 2802	2006
New	Approved Basic 06-102416BP	2003 IRC	Rambler w/attached 3 car garage	Plan:265	2006
New	Approved Basic 06-125093-BP	2003 IRC	2 story SFRw/attached garage	Plan: 2802	2006
New	Two-story residence with attached garage				2006
New	Two-story SFR with side 3-car garage -	2003 IRC			2006
New	*Issued under tax roll # 003730-023-004-02*	Approved basic 05-123201 BP	2003 IRC		2006
New	*Issued under tax roll # 003730-023-004-02*	Approved Basic Plan 05-128170BP			2006
New	*Issued under tax roll # 003730-023-004-02*	Approved basic 05-117681 BP	2003 IRC	F	2006
New	*Issued under tax roll # 003730-023-004-02*	Approved basic 05-123201 BP	2003 IRC		2006
New	Approved Basic 06-102416BP	2003 IRC	Rambler w/attached 3 car garage	Plan:265	2006
New	Approved basic 05-126157 BP	2003 IRC	Plan# 2700 B	2-story sfr w/attached g	2006
New	Approved basic 05-125349 BP	2003 IRC	Plan# 2440 A	2-story sfr w/attache	2006
New	Approved basic 05-126157 BP	2003 IRC	Plan# 2700 B	2-story sfr w/attached g	2006
New	Approved basic 05-126157 BP	2003 IRC	Plan# 2700 B	2-story sfr w/attached g	2006
New	Approved basic 05-128452 BP	2003 IRC	Plan# 2440 BE	2-story sfr w/attached gar	2006
New	Approved basic 05-126160 BP	2003 IRC	Plan# 3036 B	2-story sfr w/attached ga	2006
New	Approved basic 05-126158 BP	2003IRC	Plan# 2700 A	2-story sfr w/attached g	2006
New	Approved Basic 05-126785 BP			Plan: T2734-03A-N	2006
New	Approved Basic 06-127990BP		Plan: 5060A	Two-story SFR with attached gar	2006
New	Approved basic 05-100212BP		2 story w/attached garage	2003 IRC	Plan:50
New	Approved Basic 04-117108BP	2003 IRC	Plan: 5038 AM	Two-story SFR with att	2006
New	Approved Basic 04-117108BP		Plan: 5038 AM	Two-story SFR with attached ga	2006
New	Approved Basic 06-127990 BP		Plan: 5060A	Two-story SFR with attached ga	2006
New	Approved Basic 04-117108BP		Plan: 5038 AM	Two-story SFR with attached ga	2006
New	Approved basic 06-130426 BP	2003 IRC	Plan# 2160	2-story sfr w/attached garage	2006
New	Approved basic 06-130422 BP	2003 IRC	Plan# 1571 Rambler	2-story sfr w/attached	2006
New	Rambler with Attached Garage				2006
New	Single family residence with attached garage				2006
New	Approved Basic 06-126364 BP	2003 IRC	Plan # 2792	2-story sfr w/attached gara	2006
New	Approved basic 06-100736 BP	2003 IRC	Plan# 2564	2-story sfr w/attached gara	2006
New	Approved 06-100737 BP	2003 IRC	Plan # 2486	2-story sfr w/attached garage	2006
New	Approved basic 06-100736 BP	2003 IRC	Plan# 2564	2-story sfr w/attached gara	2006
New	Approved basic 06-100734 BP	2003 IRC	Plan# 2115	2-story sfr w/attached garag	2006
New	Approved basic 06-100734 BP	2003 IRC	Plan# 2115	2-story sfr w/attached garag	2006
New	Approved Basic 06-126364 BP	2003 IRC	Plan # 2792	2-story sfr w/attached ga	2006
New	Approved 06-100737 BP	2003 IRC	Plan # 2486	2-story sfr w/attached garage	2006
New	Approved basic 06-100736 BP	2003 IRC	Plan# 2564	2-story sfr w/attached gara	2006
New	Approved basic 06-100734 BP	2003 IRC	Plan# 2115	2-story sfr w/attached garag	2006
New	Approved basic 06-100736 BP	2003 IRC	Plan# 2564	2-story sfr w/attached gara	2006
New	Approved 06-100737 BP	2003 IRC	Plan # 2486	2-story sfr w/attached garage	2006
New	Approved Basic 06-104052BP	2003 IRC	2 story SFRw/attached garage	Plan:3376A2	2006
New	Approved Basic 06-104046BP	2003 IRC	2 story SFRw/finished bsmt & garage		2006
New	3-story sfr w/attached garage				2006
New	3 - story sfr w/attached garage				2006
New	3-story sfr w/attached garage				2006

Accessory Dwelling Units

Index # - File Name: 1.0022 - Single Family Dwellings Data\_Snohomish County.pdf

New	3-story sfr w/attached garage					2006
New	3-story sfr w/attached garage					2006
New	3-story sfr w/attached garage					2006
New	3-story sfr w/attached garage					2006
New	3-story sfr w/attached garage					2006
New	3-story sfr w/attached garage					2006
New	3-story sfr w/attached garage					2006
New	3-story sfr w/attached garage					2006
New	3-story sfr w/attached garage					2006
New	2 story SFR with finished basement and attached garage					2006
New	Approved Basic 05-118698BP	2005 IRC	2 story SFR w/attached garage	Plan:BA		2006
New	Approved Basic 05-118703BP	2003 IRC	2 story SFR w/attached garage	Plan:K-B		2006
New	Approved Basic 05-118701BP	2003 IRC	2 story SFR w/attached garage	Plan:KA		2006
New	Approved Basic 05-118706BP	2003 IRC	2 story SFR w/attached garage	Plan:DA		2006
New	Approved Basic 05-118703BP	2003 IRC	2 story SFR w/attached garage	Plan:K-B		2006
New	Approved Basic 05-118706BP	2003 IRC	2 story SFR w/attached garage	Plan:DA *		2006
New	Approved Basic 05-118701BP	2003 IRC	2 story SFR w/attached garage	Plan:KA		2006
New	Approved Basic 05-118706BP	2003 IRC	2 story SFR w/attached garage	Plan:DA		2006
New	Approved Basic 05-118703BP	2003 IRC	2 story SFR w/attached garage	Plan:K-B		2006
New	Approved Basic 05-118706BP	2003 IRC	2 story SFR w/attached garage	Plan:DA		2006
New	Approved Basic 05-118703BP	2003 IRC	2 story SFR w/attached garage	Plan:K-B		2006
New	Approved Basic 05-118706BP	2003 IRC	2 story SFR w/attached garage	Plan:DA		2006
New	Approved Basic 05-118703BP	2003 IRC	2 story SFR w/attached garage	Plan:K-B		2006
New	Approved Basic 06-102493BP	2003 IRC	2 story SFR w/attached garage	Plan:Portma		2006
New	Approved Basic 05-118701BP	2003 IRC	2 story SFR w/attached garage	Plan:KA		2006
New	Approved Basic 05-118706BP	2003 IRC	2 story SFR w/attached garage	Plan:DA		2006
New	Approved Basic 05-118703BP	2003 IRC	2 story SFR w/attached garage	Plan:K-B		2006
New	Two-story sfr with 2-story attached garage					2006
New	Approved Basic #06-104060 BP	2003 IRC		Plan: 2023	2023 sq ft	2006
New	Approved Basic #06-104060 BP	2003 IRC		Plan: 2023	2023 sq ft	2006
New	Approved Basic 06-102493BP	2003 IRC	2 story SFR w/attached garage	Plan:Portma		2006
New	Approved Basic 06-102493BP	2003 IRC	2 story SFR w/attached garage	Plan:Portma		2006
New	Approved Basic 05-122739BP	2003 IRC	3 story SFR w/attached garage	Plan:Preston		2006
New	Approved Basic 06-102497BP	2003 IRC	2 story SFR w/attached garage	Plan:Sloane		2006
New	Approved Basic 06-102494BP	2003 IRC	2 story SFR w/attached garage	Plan:Montag		2006
New	Approved Basic 06-102497BP	2003 IRC	2 story SFR w/attached garage	Plan:Sloane		2006
New	Approved Basic 05-122739BP	2003 IRC	3 story SFR w/attached garage	Plan:Preston		2006
New	Approved Basic 06-102494BP	2003 IRC	2 story SFR w/attached garage	Plan:Montag		2006
New	Approved Basic 06-102497BP	2003 IRC	2 story SFR w/attached garage	Plan:Sloane		2006
New	Approved Basic 06-102494BP	2003 IRC	2 story SFR w/attached garage	Plan:Montag		2006
New	Approved Basic 05-122739BP	2003 IRC	3 story SFR w/attached garage	Plan:Preston		2006
New	Approved Basic 06-102494BP	2003 IRC	2 story SFR w/attached garage	Plan:Montag		2006
New	Approved Basic 06-102493BP	2003 IRC	2 story SFR w/attached garage	Plan:Portma		2006
New	Approved Basic 06-126462BP		Two-story SFR with 3-car garage -	2003 IRC	Plan: 303	2006
New	Approved Basic 06-126476BP		Two-story SFR with 3-car garage	2003 IRC	Plan: 2777	2006
New	Approved basic 06-134370 BP	2003 IRC	Plan# Amesbury		2-story sfr w/attached g	2006
New	Approved Basic 06-126481BP		Two-story SFR with 3-car garage	2003 IRC	Plan: 26	2006
New	Approved Basic 06-126467BP		Two-story SFR with 3-car garage	2003 IRC	Plan: 28	2006
New	Approved Basic 06-126481BP		Two-story SFR with 3-car garage	2003 IRC	Plan: 26	2006



Accessory Dwelling Units

Index # - File Name: 1.0022 - Single Family Dwellings Data\_Snohomish County.pdf

New	Approved Basic 06-126481BP		Two-story SFR with 3-car garage	2003 IRC	Plan: 26	2006
New	Approved Basic 06-126470BP		Two-story SFR with 3-car garage	2003IRC	Plan: 2958	2006
New	Approved Basic 06-126951BP		2003 IRC	Two-story SFR with 3-car garage	Plan: 2687	2006
New	2-story sfr w/attached garage					2006
New	2-story sfr w/attached garage					2006
New	Two-story SFR with attached garage -			2003 IRC		2006
New	Approved Basic 05-121525 BP	2003 IRC	Plan# 2591		2-story sfr w/attached garage	2006
New	Two-story SFR with attached garage -			2003 IRC		2006
New	2-story sfr w/attached garage					2006
New	Approved Basic 05-121525 BP	2003 IRC	Plan# 2591		2-story sfr w/attached garage	2006
New	2-story sfr w/attached garage					2006
New	Approved basic 06-130363 BP	2003 IRC	Plan# 3016 A/B		2-story sfr w/attached ga	2006
New	Approved basic 06-130361 BP	2003 IRC	Plan# 3200 A/B		2-story sfr w/attached ga	2006
New	Approved basic 06-131199 BP	2003 IRC	Plan# 3016 B		2-story sfr w/attached gar	2006
New	Approved basic 06-130361 BP	2003 IRC	Plan# 3200 A/B		2-story sfr w/attached ga	2006
New	Approved basic 06-130363 BP	2003 IRC	Plan# 3016 A		2-story sfr w/attached gara	2006
New	Approved basic 06-130362 BP	2003 IRC	Plan# 2741 A/C		2-story sfr w/attached g	2006
New	Approved basic 06-130362 BP	2003 IRC	Plan# 2741 A/C		2-story sfr w/attached g	2006
New	2-story sfr w/attached garage					2006
New	Approved basic 06-130362 BP	2003 IRC	Plan# 2741 A/C		2-story sfr w/attached g	2006
New	Approved basic 06-130362 BP	2003 IRC	Plan# 2741 A/C		2-story sfr w/attached g	2006
New	Approved basic 06-130361 BP	2003 IRC	Plan# 3200 A/B		2-story sfr w/attached ga	2006
New	Approved basic 06-131199 BP	2003 IRC	Plan# 3016 B		2-story sfr w/attached gar	2006
New	Approved basic 06-132618 BP	2003 IRC	Plan# 2625 B		2-story sfr w/attached gara	2006
New	Approved Basic 05-120000BP	2003 IRC	Plan# Rochester		2-story sfr w/attached garage	2006
New	Two-story single family residence with attached garage					2006
New	44 ft x 64 ft two story SFR with attached garage					2006
New	Rambler with Attached Garage					2006
New	Rambler w/ attached 3 car garage					2006
New	Approved basic 06-132618 BP	2003 IRC	Plan# 2625 B		2-story sfr w/attached gara	2006
New	Approved basic 06-130360 BP	2003 IRC	Plan# 2588 A/B		2-story sfr w/attached ga	2006
New	2-story sfr w/attached garage					2006
New	Two-story residence with attached garage					2006
New	Approved Basic # 06-133071 BP		2003 IRC		Plan: Larch-248	2006
New	Approved Basic 06-134726 BP		2003 IRC		Plan: 2294	2006
New	Approved Basic 06-134846 BP		2003 IRC		Plan: 2495 Sahalee2	2006
New	Approved basic 06-132156 BP	2003 IRC	Plan# 2840		2-story sfr w/attached gara	2006
New	Approved Basic 05-116604 BP		2003 IRC		Plan: 2089	2006
New	Two Story SFR with 532sf finished attic space & attached Garage -			2003IRC		2006
New	Approved basic 06-128719 BP	2003 IRC	Plan# Plan C 2		2-story w/attic & attached	2006
New	Approved basic 06-127488 BP	2003 IRC	Plan# Plan B alt 2		2-story sfr w/attached	2006
New	Approved Basic 06- 127228BP	2003 IRC	Two-story SFR with finished attic area		Plan: B Alt. :	2006
New	Approved 06-128721 BP	2003 IRC	Plan # C Alt 1		2-story w/attic w/attached gara	2006
New	Approved basic 06-127488 BP	2003 IRC	Plan# Plan B alt 2		2-story sfr w/attached	2006
New	Approved Basic 06- 127228BP	2003 IRC	Two-story SFR with finished attic area		Plan: B Alt. :	2006
New	Approved basic 06-128719 BP	2003 IRC	Plan# Plan C 2		2-story w/attic & attached	2006
New	Approved Basic 06- 127228BP	2003 IRC	Two-story SFR with finished attic area		Plan: B Alt. :	2006

Accessory Dwelling Units

Index # - File Name: 1.0022 - Single Family Dwellings Data\_Snohomish County.pdf

New	Approved basic 06-128721 BP	2003 IRC	Plan # C Alt 1	2-story w/attic w/attached	2006
New	Approved basic 06-127488 BP	2003 IRC	Plan# Plan B alt 2	2-story sfr w/attached	2006
New	Approved basic 06-128719 BP	2003 IRC	Plan# Plan C 2	2-story w/attic & attached	2006
New	Approved basic 06-127488 BP	2003 IRC	Plan# Plan B alt 2	2-story sfr w/attached	2006
New	Approved Basic 06- 127228BP	2003 IRC	Two-story SFR with finished attic area	Plan: B Alt. :	2006
New	Approved basic 06-128721 BP	2003 IRC	Plan # C Alt 1	2-story w/attic w/attache	2006
New	Approved basic 06-127488 BP	2003 IRC	Plan# Plan B alt 2	2-story sfr w/attached	2006
New	Approved Basic 06- 127228BP	2003 IRC	Two-story SFR with finished attic area	Plan: B Alt. :	2006
New	Approved basic 06-128719 BP	2003 IRC	Plan# Plan C 2	2-story w/attic & attached	2006
New	Approved basic 06-127488 BP	2003 IRC	Plan# Plan B alt 2	2-story sfr w/attached	2006
New	Approved basic 06-129394 BP	2003 IRC	Plan Alt 2 A slab	2-story w attic sfr w/at	2006
New	Approved basic 06-129392 BP	2003 IRC	Plan Alt 1 A slab	2-story w attic sfr w/atta	2006
New	Approved basic 06-129394 BP	2003 IRC	Plan Alt 2 A slab	2-story w attic sfr w/at	2006
New	Approved basic 06-129392 BP	2003 IRC	Plan Alt 1 A slab	2-story w attic sfr w/atta	2006
New	Approved basic 06-129395 BP	2003 IRC	Plan # Alt 2 A crawlspace	2-story w attic sf	2006
New	Approved basic 06-129393 BP	2003 IRC	Plan Alt 1 A crawlspace	2-story w attic sfr w/at	2006
New	Approved basic 06-129395 BP	2003 IRC	Plan # Alt 2 A crawlspace	2-story w attic sf	2006
New	Approved basic 06-129393 BP	2003 IRC	Plan Alt 1 A crawlspace	2-story w attic sfr w/at	2006
New	Approved Basic 06-125569	2003 IRC		Plan: 2009-2 CAI	2006
New	**permits located in parent tax # 320410-004-027-00** SFR with 664 SF Finished Basement and				2006
New	2-story sfr w/attached garage				2006
New	Two-story SFR with attached garage - 2003 IRC				2006
New	Approved basic 06-132156 BP	2003 IRC	Plan# 2840	2-story sfr w/attached gara	2006
New	2006 27 X 56 Doublewide MH				2006
New	Two-story SFR with attached garage - 2003 IRC				2006
New	Two-story sfr with garage in lower level				2006
New	Two story SFR with attached Garage				2006
New	Approved basic 06-130291 BP	2003 IRC	Plan# 3531	2-story sfr w/attached gi	2006
New	Approved basic 06-125198 BP	2003 IRC	Plan# 2736	2-story sfr w/attached garage	2006
New	Approved basic 06-125198 BP	2003 IRC	Plan# 2736	2-story sfr w/attached garage	2006
New	Approved basic 06-125198 BP	2003 IRC	Plan# 2736	2-story sfr w/attached garage	2006
New	Approved basic 06-125198 BP	2003 IRC	Plan# 2736	2-story sfr w/attached garage	2006
New	Approved basic 06-125198 BP	2003 IRC	Plan# 2736	2-story sfr w/attached garage	2006
New	Approved basic 06-130291 BP	2003 IRC	Plan# 3531	2-story sfr w/attached gi	2006
New	Approved basic 06-130291 BP	2003 IRC	Plan# 3531	2-story sfr w/attached gi	2006
New	Approved basic 06-126880 BP	2003 IRC	Plan# TS 110 B/C	2-story sfr w/attached gara	2006
New	Approved basic 06-126880 BP	2003 IRC	Plan# TS 110 B/C	2-story sfr w/attached gara	2006
New	Approved basic 06-126880 BP	2003 IRC	Plan# TS 110 B/C	2-story sfr w/attached gar	2006
New	Approved basic 06-124984 BP	2003 IRC	Plan# TS 114 B	2-story sfr w/attached gar	2006
New	Approved basic 06-124987 BP	2003 IRC	Plan# TS 115 B	2-story sfr w/attached gara	2006
New	NOTE: permit finalled with permit fees still owing. Approved basic 06-124976 BP				2003 IF
New	Approved basic 06-124987 BP	2003 IRC	Plan# TS 115 B	2-story sfr w/attached gara	2006
New	Approved basic 06-126882 BP	2003 IRC	Plan# DP 117 A	2-story duplex w/attached	2006
New	Approved basic 06-124985 BP	2003 IRC	Plan# TS 115 A	2-story sfr w/attached ga	2006
New	Approved basic 06-124987 BP	2003 IRC	Plan# TS 115 B	2-story sfr w/attached gara	2006
New	Approved basic 06-124976 BP	2003 IRC	Plan #TS 113 A/B	2-story sfr w/attached	2006
New	Approved basic 06-124985 BP	2003 IRC	Plan# TS 115 A	2-story sfr w/attached ga	2006

Accessory Dwelling Units

Index # - File Name: 1.0022 - Single Family Dwellings Data\_Snohomish County.pdf

New	Approved basic 06-124983 BP	2003 IRC	Plan# TS 114 A	2-story sfr w/attached ga	2006
New	Approved basic 06-124984 BP	2003 IRC	Plan# TS 114 B	2-story sfr w/attached gar	2006
New	Approved basic 06-124985 BP	2003 IRC	Plan# TS 115 A	2-story sfr w/attached ga	2006
New	Approved basic 06-124976 BP	2003 IRC	Plan #TS 113 A/B	2-story sfr w/attached	2006
New	Approved basic 06-124985 BP	2003 IRC	Plan# TS 115 A	2-story sfr w/attached ga	2006
New	Approved basic 06-124983 BP	2003 IRC	Plan# TS 114 A	2-story sfr w/attached ga	2006
New	Approved basic 06-124976 BP	2003 IRC	Plan #TS 113 A/B	2-story sfr w/attached	2006
New	Two-story sfr with attached garage				2006
New	Approved basic 06-124980 BP	2003 IRC	Plan# TS 111 B	2-story sfr w/attached ;	2006
New	Approved basic 06-124982 BP	2003 IRC	Plan # TS 112 A	2-story sfr w/attache	2006
New	Approved basic 06-124977 BP	2003 IRC	Plan# TS 111 A	2-story sfr w/attache	2006
New	Approved basic 06-124982 BP	2003 IRC	Plan # TS 112 A	2-story sfr w/attache	2006
New	Approved basic 06-124980 BP	2003 IRC	Plan# TS 111 B	2-story sfr w/attached ;	2006
New	Approved basic 06-126882 BP	2003 IRC	Plan# DP 117 A	2-story duplex w/attached	2006
New	Approved basic 06-124981 BP	2003 IRC	Plan TS 110 A	2-story sfr w/attached garag	2006
New	Approved basic 06-126880 BP	2003 IRC	Plan# TS 110 B/C	2-story sfr w/attached gar	2006
New	Approved basic 06-124981 BP	2003 IRC	Plan TS 110 A	2-story sfr w/attached garag	2006
New	Two-story sfr with attached garage				2006
New	Two-story sfr with attached garage				2006
New	Two story SFR with attached Garage				2006
New	Two-story residence with attached garage				2006
New	3079 sq ft single family residence with attached 1014 sq ft garge.				2006
New	*Issued under tax roll # 008578-000-013-01*	Approved Basic 06-133333BP	2003 IRC	Tw	2006
New	*Issued under tax roll # 008578-000-013-01*	Approved Basic 05-124072BP	2003 IRC	2	2006
New	*Issued under tax roll # 008578-000-013-01*	Approved Basic 05-124072BP	2003 IRC	2	2006
New	See 08-102271 *Issued under tax roll # 008578-000-013-01* Approved Basic 06 127331 BP				2006
New	EXPIRED WITHOUT COUNTY APPROVAL TO USE OR OCCUPY. SENT TO MICROFICHE. 7/17/08 Tw				2006
New	Rambler w/ attchd 3 car garage				2006
New	Approved Basic 05-121010BP	2003 IRC	2 story SFR w/attached garage	Plan:2452	2006
New	2-story SFR w/attached garage.				2006
New	2-Story SFR w/attached garage.				2006
New	Approved Basic 05-121010BP	2003 IRC	2 story SFR w/attached garage	Plan:2452	2006
New	Rambler style SFR w/attached garage				2006
New	Two-story residence with attached garage				2006
New	Two-story sfr with attached garage				2006
New	Rambler with attached garage				2006
New	2 story SFR w/ attached 3 car garage				2006
New	98 ft x 132 ft irregular two story SFR with attached garage				2006
New	Approved basic 05-128493 BP	2003 IRC	Plan# Jackson	2-story sfr w/attached	2006
New	Approved basic 06-129807 BP	2003 IRC	Plan# Roselyn	2-story sfr w/attached	2006
New	Approved basic 06-129803 BP	2003 IRC	Plan# Harrington	2-story sfr w/attached	2006
New	Approved basic 05-128758 BP	2003 IRC	Plan# Elanor	2-story sfr w/attached garag	2006
New	Approved basic 06-129807 BP	2003 IRC	Plan# Roselyn	2-story sfr w/attached	2006
New	Approved basic 05-128493 BP	2003 IRC	Plan# Jackson	2-story sfr w/attached	2006
New	Approved basic 05-128758 BP	2003 IRC	Plan# Elanor	2-story sfr w/attached garag	2006
New	Approved basic 06-129803 BP	2003 IRC	Plan# Harrington	2-story sfr w/attached	2006
New	*Issued under tax roll # 005385-000-013-01* Approved Basic 05-124813 BP				2003 IRC 2 2006

Accessory Dwelling Units

Index # - File Name: 1.0022 - Single Family Dwellings Data\_Snohomish County.pdf

New	*Issued under tax roll # 005385-000-013-01* ? filed under TA#300516-004-003-00	Approved Basic	06-128084 BP	2003 IRC	Plan: 2076	2-story sfr w/ attached garage	2006
New	Approved Basic 06-128084 BP	2003 IRC					2006
New	*Issued under tax roll # 005385-000-013-01*	Approved Basic	06-128084 BP	2003 IRC	PI		2006
New	*Issued under tax roll # 005385-000-013-01*	Approved Basic	06-128084 BP	2003 IRC	PI		2006
New	Two-story SFR w/ attchd. 2 car garage						2006
New	2-story SFR w/unfinished basement and garage						2006
New	Approved basic 06-126164 BP	2003 IRC		Plan# 1418 A		2-story sfr w/attached garage	2006
New	Approved Basic 05-126112BP	2003 IRC				2 story SFR w/attached garage Plan:1418B	2006
New	Approved Basic 05-126112BP	2003 IRC				2 story SFR w/attached garage Plan:1418B	2006
New	Approved basic 06-127347 BP	2003 IRC		Plan# 1318 A		2-story sfr w/attached gar	2006
New	Approved Basic 05- 1000527BP						2006
New	Approved basic 06-127347 BP	2003 IRC		Plan# 1318 A		2-story sfr w/attached gar	2006
New	Approved Basic 05-118601BP	2003 IRC				2 story SFR w/attached garage Plan:1731B	2006
New	Approved Basic 05-126112BP	2003 IRC				2 story SFR w/attached garage Plan:1418B	2006
New	Approved basic 06-125342 BP	2003 IRC		Plan# 1319 A		2-story sfr w/attached	2006
New	Approved basic 06-126164 BP	2003 IRC		Plan# 1418 A		2-story sfr w/attached garage	2006
New	Approved Basic 05-126112BP	2003 IRC				2 story SFR w/attached garage Plan:1418B	2006
New	Approved Basic 06-130347-BP	2003 IRC		Plan# 1717 A		2-story sfr w/attached gara	2006
New	Approved Basic 06-130350-BP	2003 IRC		Plan# 1717 C		2-story sfr w/attached gara	2006
New	Approved Basic 06-130347-BP	2003 IRC		Plan# 1717 A		2-story sfr w/attached gara	2006
New	Approved Basic 06-130350-BP	2003 IRC		Plan# 1717 C		2-story sfr w/attached gara	2006
New	Approved basic 06-128446 BP	2003 IRC		Plan# 1117 B		2-story sfr w/attached gara	2006
New	Approved basic 06-125882 BP	2003 IRC		Plan# 1618 A		2-story sfr w/attached gara	2006
New	Approved basic 06-126164 BP	2003 IRC		Plan# 1418 A		2-story sfr w/attached garage	2006
New	Approved Basic 06-130350-BP	2003 IRC		Plan# 1717 C		2-story sfr w/attached gara	2006
New	Approved basic 06-131905 BP	2003 IRC		Plan# 1319 C		2-story sfr w/attached gara	2006
New	Approved Basic 06-134458BP	2003 IRC				Two story SFR with attached garage Plan: 2365A	2006
New	Approved Basic 06-128073 BP	2003 IRC		Plan: #2733		2-story sfr w/attached garage *issu	2006
New	Approved Basic 06-128808 BP	2003 IRC		Plan: #2672		2-story sfr w/attached garage *issu	2006
New	Approved Basic 06-128073 BP	2003 IRC		Plan: #2733		2-story sfr w/attached garage *issu	2006
New	Approved Basic 06-128080 BP	2003 IRC		Plan: #2672		2-story sfr w/attached garage *issu	2006
New	Quadruple-wide 2006 Barrington Mobile Home on a foundation						2006
New	Approved Basic 06-102497BP	2003 IRC				2 story SFR w/attached garage Plan:Sloane	2006
New	Approved Basic 06-102497BP	2003 IRC				2 story SFR w/attached garage Plan:Sloane	2006
New	Approved Basic 06-102495BP	2003 IRC				2 story SFR w/attached garage Plan:Soho	2006
New	Approved Basic 06-102491BP	2003 IRC				2 story SFR w/attached garage Plan:Cadago	2006
New	*Issued under tax roll # 270516-002-005-00*	Approved Basic	05-128615BP	2003 IRC	2		2006
New	*Issued under tax roll # 270516-002-005-00*	Approved basic	06-125104 BP	2003 IRC			2006
New	*Issued under tax roll # 270516-002-005-00*	Approved Basic	06-101697BP	2003 IRC	2		2006
New	*Issued under tax roll # 270516-002-005-00*	Approved Basic	05-128624BP	2003 IRC	2 sto		2006
New	*Issued under tax roll # 270516-002-005-00*	Approved Basic	06-101697BP	2003 IRC	2		2006
New	*Issued under tax roll # 270516-002-005-00*	Approved Basic	06-101697BP	2003 IRC	2		2006
New	*Issued under tax roll # 270516-002-005-00*	Approved Basic	05-128615BP	2003 IRC	2		2006
New	*Issued under tax roll # 270516-002-005-00*	Approved basic	06-125104 BP	2003 IRC			2006
New	*Issued under tax roll # 270516-002-005-00*	Approved Basic	05-128625	2003 IRC	2 stor		2006
New	*Issued under tax roll # 270516-002-005-00*	Approved Basic	05-128615BP	2003 IRC	2		2006
New	Approved Basic 05-128625	2003 IRC				2 story SFR w/attached garage Plan:1189	2006

Accessory Dwelling Units

Index # - File Name: 1.0022 - Single Family Dwellings Data\_Snohomish County.pdf

New	*Issued under tax roll # 270516-002-005-00*	Approved Basic 06-101697BP	2003 IRC	2	2006
New	*Issued under tax roll # 270516-002-005-00*	Approved basic 06-125104 BP	2003 IRC		2006
New	*Issued under tax roll # 270516-002-005-00*	Approved Basic 05-128615BP	2003 IRC	2	2006
New	*Issued under tax roll # 270516-002-005-00*	Approved Basic 06-101697BP	2003 IRC	2	2006
New	*Issued under tax roll # 270516-002-005-00*	Approved Basic 05-128625	2003 IRC	2 stor	2006
New	*Issued under tax roll # 270516-002-005-00*	Approved Basic 05-128838BP	2003 IRC		2006
New	*Issued under tax roll # 270516-002-005-00*	Approved Basic 05-128622BP	2003 IRC	2 s	2006
New	*Issued under tax roll # 270516-002-005-00*	Approved Basic 06-101697BP	2003 IRC	2	2006
New	*Issued under tax roll # 270516-002-005-00*	Approved Basic 05-128625	2003 IRC	2 stor	2006
New	*Issued under tax roll # 270516-002-005-00*	Approved Basic 05-128838BP	2003 IRC		2006
New	*Issued under tax roll # 270516-002-005-00*	Approved Basic 05-128622BP	2003 IRC	2 s	2006
New	*Issued under tax roll # 270516-002-005-00*	Approved Basic 05-128838BP	2003 IRC		2006
New	*Issued under tax roll # 270516-002-005-00*	Approved Basic 05-128624BP	2003 IRC	2 sto	2006
New	*Issued under tax roll # 270516-002-005-00*	Approved Basic 05-128838BP	2003 IRC		2006
New	*Issued under tax roll # 270516-002-005-00*	Approved Basic 06-101697BP	2003 IRC	2	2006
New	*Issued under tax roll # 270516-002-005-00*	Approved Basic 05-128625	2003 IRC	2 stor	2006
New	*Issued under tax roll # 270516-002-005-00*	Approved Basic 05-128838BP	2003 IRC		2006
New	*Issued under tax roll # 270516-002-005-00*	Approved Basic 05-128625	2003 IRC	2 stor	2006
New	*Issued under tax roll # 270516-002-005-00*	Approved Basic 05-128615BP	2003 IRC	2	2006
New	*Issued under tax roll # 270516-002-005-00*	Approved basic 06-125104 BP	2003 IRC		2006
New	*Issued under tax roll # 270516-002-005-00*	Approved Basic 05-128615BP	2003 IRC	2	2006
New	*Issued under tax roll # 270516-002-005-00*	Approved Basic 05-128625	2003 IRC	2 stor	2006
New	*Issued under tax roll # 270516-002-005-00*	Approved basic 06-125104 BP	2003 IRC		2006
New	*Issued under tax roll # 270516-002-005-00*	Approved basic 06-125104 BP	2003 IRC		2006
New	*Issued under tax roll # 270516-002-005-00*	Approved Basic 05-128615BP	2003 IRC	2	2006
New	*Issued under tax roll # 270516-002-005-00*	Approved Basic 05-128615BP	2003 IRC	2	2006
New	*Issued under tax roll # 270516-002-005-00*	Approved Basic 05-128615BP	2003 IRC	2	2006
New	*Issued under tax roll # 270516-002-005-00*	Approved basic 06-125104 BP	2003 IRC		2006
New	*Issued under tax roll # 270516-002-005-00*	Approved Basic 05-128625	2003 IRC	2 stor	2006
New	Approved Basic 06-102495BP	2003 IRC	2 story SFR w/attached garage	Plan:Soho	2006
New	Approved Basic 06-102494BP	2003 IRC	2 story SFR w/attached garage	Plan:Montag	2006
New	Approved Basic 06-102495BP	2003 IRC	2 story SFR w/attached garage	Plan:Soho	2006
New	Approved Basic 06-102491BP	2003 IRC	2 story SFR w/attached garage	Plan:Cadago	2006
New	Approved Basic 06-102495BP	2003 IRC	2 story SFR w/attached garage	Plan:Soho	2006
New	Approved Basic 06-102491BP	2003 IRC	2 story SFR w/attached garage	Plan:Cadago	2006
New	Approved Basic 06-102494BP	2003 IRC	2 story SFR w/attached garage	Plan:Montag	2006
New	Approved Basic 06-102494BP	2003 IRC	2 story SFR w/attached garage	Plan:Montag	2006
New	Approved Basic 06-102491BP	2003 IRC	2 story SFR w/attached garage	Plan:Cadago	2006
New	Approved Basic 06-102497BP	2003 IRC	2 story SFR w/attached garage	Plan:Sloane	2006
New	Approved Basic 06-102495BP	2003 IRC	2 story SFR w/attached garage	Plan:Soho	2006
New	Approved Basic 06-102494BP	2003 IRC	2 story SFR w/attached garage	Plan:Montag	2006
New	Approved Basic 05-122739BP	2003 IRC	3 story SFR w/attached garage	Plan:Preston	2006
New	Applicants copy of inspection card was signed by Rick Roberts 2-27-07(he did not sign Co. copy)				2006
New	*Issued under tax roll # 270516-002-005-00*	Approved Basic 05-128615BP	2003 IRC	2	2006
New	*Issued under tax roll # 270516-002-005-00*	Approved basic 06-125104 BP	2003 IRC		2006
New	*Issued under tax roll # 270516-002-005-00*	Approved Basic 06-101697BP	2003 IRC	2	2006
New	*Issued under tax roll # 270516-002-005-00*	Approved Basic 05-128838BP	2003 IRC		2006

Accessory Dwelling Units

Index # - File Name: 1.0022 - Single Family Dwellings Data\_Snohomish County.pdf

New	*Issued under tax roll # 270516-002-005-00*	Approved Basic 05-128615BP	2003 IRC	2	2006
New	*Issued under tax roll # 270516-002-005-00*	Approved basic 06-125104 BP	2003 IRC		2006
New	*Issued under tax roll # 270516-002-005-00*	Approved Basic 05-128622BP	2003 IRC	2 s	2006
New	EXPIRED WITHOUT COUNTY APPROVAL TO USE OR OCCUPY 12/01/08 DM	*Issued under tax ro			2006
New	*Issued under tax roll # 270516-002-005-00*	Approved basic 06-125104 BP	2003 IRC		2006
New	*Issued under tax roll # 270516-002-005-00*	Approved Basic 05-128622BP	2003 IRC	2 s	2006
New	*Issued under tax roll # 270516-002-005-00*	Approved Basic 05-128624BP	2003 IRC	2 sto	2006
New	*Issued under tax roll # 270516-002-005-00*	Approved Basic 06-101697BP	2003 IRC	2	2006
New	*Issued under tax roll # 270516-002-005-00*	Approved basic 06-125104 BP	2003 IRC		2006
New	*Issued under tax roll # 270516-002-005-00*	Approved Basic 05-128625	2003 IRC	2 stor	2006
New	*Issued under tax roll # 270516-002-005-00*	Approved Basic 05-128625	2003 IRC	2 stor	2006
New	*Issued under tax roll # 270516-002-005-00*	Approved Basic 05-128615BP	2003 IRC	2	2006
New	*Issued under tax roll # 270516-002-005-00*	Approved Basic 05-128625	2003 IRC	2 stor	2006
New	*Issued under tax roll # 270516-002-005-00*	Approved basic 06-125104 BP	2003 IRC		2006
New	*Issued under tax roll # 270516-002-005-00*	Approved Basic 05-128625	2003 IRC	2 stor	2006
New	*Issued under tax roll # 270516-002-005-00*	Approved basic 06-125104 BP	2003 IRC		2006
New	*Issued under tax roll # 270516-002-005-00*	Approved basic 06-125104 BP	2003 IRC		2006
New	*Issued under tax roll # 270516-002-005-00*	Approved Basic 05-128615BP	2003 IRC	2	2006
New	*Issued under tax roll # 270516-002-005-00*	Approved Basic 05-128625	2003 IRC	2 stor	2006
New	*Issued under tax roll # 270516-002-005-00*	Approved basic 06-125104 BP	2003 IRC		2006
New	*Issued under tax roll # 270516-002-005-00*	Approved Basic 05-128615BP	2003 IRC	2	2006
New	Two-story SFR with attached garage -	2003 IRC			2006
New	Rambler with Attached Garage				2006
New	*Issued under tax roll # 005338-000-022-00*	Two-story duplex with attached garages			2006
New	Approved Basic 05-100241BP	2003 IRC	Plan: 1561	2 story Duplex w/attached ga	2006
New	Two story SFR with Attached Garage				2006
New	Two Story SFR with Attached Garage				2006
New	Rambler with attached 3 car garage				2006
New	Rambler style w/garage and covered deck				2006
New	2,318 sq ft Rambler with attached Garage				2006
New	Rambler style w/garage and covered porch				2006
New	2 story Duplex w/ 2 car attached garage & covered porch				2006
New	Approved Basic 06-129277 BP	2003 IRC	Plan 2805	2-story sfr w/attached gar	2006
New	Approved Basic 06-129276 BP	2003 IRC	Plan: 2840	Two-story home with attached 2 ca	2006
New	2-story w/garage				2006
New	Approved basic 06-124917 BP	2003 IRC	Plan 3200 A	2-story sfr w/attached gara	2006
New	Approved basic 06-124911 BP	2003 IRC	Plan 2588 B	2-story sfr w/attached ga	2006
New	Approved basic 06-124917 BP	2003 IRC	Plan 3200 A	2-story sfr w/attached gara	2006
New	Approved basic 06-124912 BP	2003 IRC	Plan 2588 A	2-story sfr w/attached ;	2006
New	Approved basic 06-129261 BP	2003 IRC	Plan 3016 A	2-story sfr w/attached garage	2006
New	Two story SFR with attached Garage				2006
New	2 story SFR w/ attached 2 car garage				2006
New	Rambler with attached garage				2006
New	70 x 24 doublewide 1974 MH				2006
New	2-story w/garage				2006
New	Approved basic 06-124911 BP	2003 IRC	Plan 2588 B	2-story sfr w/attached ga	2006
New	Approved basic 06-129261 BP	2003 IRC	Plan 3016 A	2-story sfr w/attached garage	2006

Accessory Dwelling Units

Index # - File Name: 1.0022 - Single Family Dwellings Data\_Snohomish County.pdf

New	Approved basic 06-124917 BP	2003 IRC	Plan 3200 A	2-story sfr w/attached gara	2006
New	Approved Basic # 06-102156 BP	2003 IRC	Plan: 2996-B	Two story SFR w/ attached Gara	2006
New	2-story sfr w/attached garage				2006
New	Approved basic 06-124918 BP	2003 IRC	Plan 2996 A	2-story sfr w/attached gara	2006
New	Approved basic 06-124919 BP	2003 IRC	Plan 3271 B	2-story sfr w/attached j	2006
New	2-story sfr w/attached garage				2006
New	Approved basic 06-133571 BP	2003 IRC	Plan# 2658 A	2-story sfr w/attached garage	2006
New	Approved Basic 05-120703BP	2003 IRC	2 story SFR w/attached garage	Plan:2755-A	2006
New	Approved basic 06-124908 BP	2003 IRC	Plan 2842 A	2-story sfr w/attached garage	2006
New	2-story sfr w/attached garage				2006
New	Approved basic 06-124917 BP	2003 IRC	Plan 3200 A	2-story sfr w/attached gara	2006
New	Rambler w/ attached 3 car garage				2006
New	Approved basic 06-132144 BP	2003 IRC	Plan# 2838	2-story sfr w/attached garage	2006
New	Approved basic 06-132144 BP	2003 IRC	Plan# 2838	2-story sfr w/attached garage	2006
New	Approved basic 06-132143 BP	2003 IRC	Plan # 2482	2-story sfr w/attached garage	2006
New	Approved basic 06-132163 BP	2003 IRC	Plan# 2680	2-story sfr w/attached gara	2006
New	Approved basic 06-132163 BP	2003 IRC	Plan# 2680	2-story sfr w/attached garag	2006
New	Rambler with attached garage				2006
New	Two story SFR with attached Garage				2006
New	Approved basic 06-132163 BP	2003 IRC	Plan# 2680	2-story sfr w/attached gara	2006
New	Approved basic 06-132143 BP	2003 IRC	Plan # 2482	2-story sfr w/attached garage	2006
New	Approved basic 06-132144 BP	2003 IRC	Plan# 2838	2-story sfr w/attached garage	2006
New	Approved basic 06-132143 BP	2003 IRC	Plan # 2482	2-story sfr w/attached garage	2006
New	Approved basic 06-132144 BP	2003 IRC	Plan# 2838	2-story sfr w/attached garage	2006
New	Approved basic 05-126160 BP	2003 IRC	Plan# 3036 B	2-story sfr w/attached ga	2006
New	Approved basic 05-126157 BP	2003 IRC	Plan# 2700 B	2-story sfr w/attached g	2006
New	Approved basic 05-128449 BP	2003 IRC	Plan# 2440 AE	2-story sfr w/attached g	2006
New	Approved Basic 06-132059BP	2003 IRC	Two-story SFR with attached garage	Plan: T2472-02A-	2006
New	Approved Basic 06-127063-BP	2003 IRC	2 story SFR w/attached garage	Plan:2498	2006
New	Approved Basic 06-127061-BP	2003 IRC	2 story SFR w/attached garage	Plan:2295	2006
New	Approved Basic 06-127066-BP	2003 IRC	2 story SFR w/attached garage	Plan:2420	2006
New	SENT PERMIT FOLDER TO RECORDS ROOM 10/27/08 DM	Approved Basic 06-127063-BP	2003 I		2006
New	Two story SFR with attached Garage				2006
New	1152 sq ft SFR in Town of Index. (No garage)				2006
New	1152 sq ft SFR in Town of Index. (No garage)				2006
New	1992 Fleetwood mobile home				2006
New	1989 Skyline mobile home				2006
New	48 x 26 SFR with garage				2006
New	30 x 40 two story SFR with garage				2006
New	30 x 40 two story SFR with garage				2006
New	Approved Basic 05-117923BP	2003 IRC	Plan:2585A	2 story SFR w/attached gara	2006
New	Approved Basic 05-124786BP	2003 IRC	2 story SFR w/attached garage	Plan:2175A	2006
New	Approved Basic 05-122161 BP	2003 IRC	Plan# 3131C	2 - story sfr w/attached ga	2006
New	Approved Basic 05-117923BP	2003 IRC	Plan:2585A	2 story SFR w/attached gara	2006
New	Approved Basic 05-118591BP	2003 IRC	2 story SFR w/attached garage	Plan:2011	2006
New	Approved Basic 05-100758BP	2003 IRC	Plan:2021A		2006
New	Approved Basic 05-119426BP	2003 IRC	2 story SFR w/attached garage	Plan:2441	2006

Accessory Dwelling Units

Index # - File Name: 1.0022 - Single Family Dwellings Data\_Snohomish County.pdf

New	Approved Basic 06-133269BP - 2003 IRC	Two-story SFR with attached garage	Plan: 2441 C	2006
New	Approved Basic 05-124092BP	2003 IRC	2 story SFR w/attached garage	Plan:2511 A & C 2006
New	Approved basic 06-132293 BP	2003 IRC	Plan# 2155 A	2-story sfr w/attached gara 2006
New	Approved Basic 06-134965 BP	2003 IRC	Builder Plan# 1613 A	Ramble 2006
New	Approved basic 06-130553 BP	2003 IRC	Plan# 2740	2-story sfr w/attached garage 2006
New	2-story SFR w/garage			2006
New	Rambler style w/garage			2006
New	Approved Basic 06-131359-BP	2003 IRC	Plan#1214-Split	Split Entry SFR w/unfin. bsr 2006
New	Approved basic 06-130546 BP	2003 IRC	Plan# 2130	2-story sfr w/attached garage 2006
New	Approved basic 06-130552 BP	2003 IRC	Plan# 2126	2-story sfr w/attached garage 2006
New	Approved basic 06-131596 BP	2003 IRC	Plan# 1840	2-story sfr w/attached ga 2006
New	Approved basic 06-130552 BP	2003 IRC	Plan# 2126	2-story sfr w/attached garage 2006
New	Approved basic 06-130541 BP	2003 IRC	Plan# 2305	2-story sfr w/attached garage 2006
New	Approved basic 06-130543 BP	2003 IRC	Plan# 2315	2-story sfr w/attached garage 2006
New	Approved basic 06-130552 BP	2003 IRC	Plan# 2126	2-story sfr w/attached garage 2006
New	Approved Basic 04-115831 BP	2 story SFR w/attached garage	2003 IRC	Plan:2797 ref: vo 2006
New	Approved basic 06-131791 BP	2003 IRC	Plan# 2620	2-story sfr w/attache 2006
New	Approved basic 06-134177 BP	2003 IRC	Plan# Waterton Gable B (I)	2-story sfr w/attac 2006
New	Approved basic 06-134179 BP	2003 IRC	Plan# Lafayette Gable B (I)	2-story sfr w/atta 2006
New	Approved basic 06-133592 BP	2003 IRC	Plan# Shasta Gable	2-story sfr w/attached ga 2006
New	Approved basic 06-134178 BP	2003 IRC	Plan# Purcell Gable A (I)	2-story sfr w/attached 2006
New	Approved basic 06-134664 BP	2003 IRC	Plan # 2464	2-story sfr w/attached garage 2006
New	2-story sfr w/attached garage			2006
New	Approved Basic 06-134968BP - 2003IRC	Two-story SFR with attached garage	Plan: Langley Hip	2006
New	Approved basic 06-133934 BP	2003 IRC	Plan# Shasta Gable A (I)	2-story sfr w/attache 2006
New	Approved basic 06-133935 BP	2003 IRC	Plan# Adams Gable A (I)	2-story sfr w/attac 2006
New	Approved basic 06-133592 BP	2003 IRC	Plan# Shasta Gable	2-story sfr w/attached ga 2006
New	Approved basic 06-133591 BP	2003 IRC	Plan# Madison Hip A	2-story sfr w/attached gi 2006
New	Approved basic 06-129078 BP	2003 IRC	Plan# 2838	2 story with attached 3 car gara 2006
New	2-Story SFR w/attached garage			2006
New	82 ft x 88 ft irregular SFR with unfinished daylight basement			2006
New	Two-story SFR with attached garage - 2003 IRC		Plan: 2774B	2006
New	Two-story SFR with attached garage - 2003 IRC		Plan: 2976	2006
New	Two-story SFR with attached garage - 2003 IRC		Plan: 3162	2006
New	Two-story SFR with attached garage - 2003 IRC		Plan: 2967	2006
New	Two-story SFR with attached garage - 2003 IRC		Plan: 3162	2006
New	2-Story SFR w/attached garage.			2006
New	Approved Basic 06-128686BP	2003IRC	Two-story SFR with attached garage	Plan: 2 2006
New	Approved Basic # 06-133200 BP	2003 IRC	Plan: 2396 DD	2-story SFR w/attached gara 2006
New	Approved basic 06-131285 BP	2003 IRC	Plan# 2396 (2)	2-story sfr w/attached gara 2006
New	Approved Basic 06-128686BP	2003IRC	Two-story SFR with attached garage	Plan: 2 2006
New	Approved basic 06-131285 BP	2003 IRC	Plan# 2396 (2)	2-story sfr w/attached gara 2006
New	Approved basic 06-127957 BP	2003 IRC	Plan# 2381	2-story sfr w/attached garage 2006
New	Approved Basic # 06-133200 BP	2003 IRC	Plan: 2396 DD	2-story SFR w/attached gara 2006
New	Approved basic 06-101007 BP	2003 IRC	Plan# 2212	2-story sfr w/attached garag 2006
New	Approved basic 06-128299 BP	2003 IRC	Plan# 2454	2-story sfr w/attached garag 2006
New	Approved basic 06-127957 BP	2003 IRC	Plan# 2381	2-story sfr w/attached garag 2006



Accessory Dwelling Units

Index # - File Name: 1.0022 - Single Family Dwellings Data\_Snohomish County.pdf

New	*Issued under tax roll # 005092-002-016-00*	Approved basic 06-134216 BP	2003 IRC	Pl:	2006
New	*Issued under tax roll # 005092-002-016-00*	Approved Basic 06-124907BP	2003 IRC	2 st	2006
New	STOP WORK ORDER 8/4/06 Lifted by Mick 9/21/06 One-story SFR				2006
New	2-story SFR w/garage				2006
New	3219 sq ft single family residence with 1493 sq ft unfinished basement and 828 sq ft attached garage				2006
New	Approved Basic 06-100605-BP		2003 IRC	Plan:Belmont 2-Story SFRw/	2006
New	2 Story SFR w/ 3 Car				2006
New	3 bedroom Rambler, 2383 sqft				2006
New	Convert existing building to Detached Accessory Apt				2006
New	Approved Basic 06-100605-BP		2003 IRC	Bldr. Plan MU3DB-454	2006
New	Approved Basic # 05-126861BP	2003 IRC	SFR w/finished basement	Plan: R3DB-426	2006
New	Approved Basic 06-100605-BP	2003 IRC		Plan:Belmont. 2-Story SFR over	2006
New	Approved Basic 04-117562BP		Plan: G522-A	Two-story SFR with attached	2006
New	Approved Basic 04-116879BP		Plan: G524-A	Two-story SFR with attached	2006
New	Approved Basic 04-117864BP		Plan: G523-B	Two-story SFR with attached	2006
New	Approved Basic 04-117566BP		Plan: G522-C	Two-story SFR with attached	2006
New	Approved Basic 04-118907BP	2 story SFR w/attached garage	2003 IRC	Plan:G531-A	2006
New	Approved Basic 04-117862BP		Plan: G523-A	Two-story SFR with attached	2006
New	Approved Basic 04-117864BP		Plan: G523-B	Two-story SFR with attached	2006
New	Approved Basic 04-116881BP		Plan: G524-C	Two-story SFR with attached	2006
New	Approved Basic 04-117565BP		Plan: G522-B	Two-story SFR with attached	2006
New	Approved Basic 04-118907BP	2 story SFR w/attached garage	2003 IRC	Plan:G531-A	2006
New	Approved Basic 04-118908BP	2 story SFR w/attached garage	2003 IRC	Plan:G531-B	2006
New	Approved Basic 04-117862BP		Plan: G523-A	Two-story SFR with attached	2006
New	Approved Basic 04-116881BP		Plan: G524-C	Two-story SFR with attached	2006
New	Approved Basic 04-117382BP		Plan B.125.B	Two Story SF	2006
New	Approved Basic 04-117562BP		Plan: G522-A	Two-story SFR with attached	2006
New	Approved Basic 04-117862BP		Plan: G523-A	Two-story SFR with attached	2006
New	Approved basic 05-123494 BP	2003 IRC	Plan B-134-A	2-story sfr w/attached garage	2006
New	Approved Basic 04-117562BP		Plan: G522-A	Two-story SFR with attached	2006
New	Approved Basic 04-117385BP		Plan B.125.A	Two Story SFR with Attached	2006
New	Approved Basic 04-117864BP		Plan: G523-B	Two-story SFR with attached	2006
New	Approved Basic 04-117382BP		Plan B.125.B	Two Story SF	2006
New	One-story SFR with attached Garage. Inspections up to sheetrock were finalized on 03-109220RK				2006
New	Ramble style SFR w/attached garage				2006
New	2-story sfr w/attached garage				2006
New	2 story SFR w/ unfinished basement, attchd 3 car garage				2006
New	2-Story SFR w/attached garage and covered porch				2006
New	Approved Basic 06-102416BP	2003 IRC	Rambler w/attached 3 car garage	Plan:265	2006
New	Approved Basic 05 129105 BP			Builder s Plan: 2650 2 S	2006
New	3369 sq ft SFR with 1102 sq ft attached garage.				2006
New	2 story w/ attached 3 car garage				2006
New	One Story SFR		1997 UBC		2006
New	Rambler style SFR w/bonus room over attached garage.				2006
New	Approved Basic 06-100024BP	2003 IRC	2 story SFR w/attached garage	Plan:255	2006
New	Approved Basic 05-117923BP	2003 IRC	Plan:2585A	2 story SFR w/attached gara	2006
New	Approved Basic 06-10021BP	2003 IRC	2 story SFR w/attached garage	Plan:2155B	2006

Accessory Dwelling Units

Index # - File Name: 1.0022 - Single Family Dwellings Data\_Snohomish County.pdf

New	Approved Basic 05-122161 BP	2003 IRC	Plan# 3131C	2 - story sfr w/attached ga	2006
New	2 story SFR w/attached garage	2003 IRC			2006
New	2847 sq ft Rambler with attached Garage				2006
New	2005 48 ft X 26 ft 8 in Doublewide MH				2006
New	2 story SFR w/ attchd 3 car garage				2006
New	Approved Basic # 06-100585 BP	2003 IRC		Plan: 0215 T	2006
New	Approved Basic 05- 128571BP	2003 IRC		Plan: 0123 Two-story S	2006
New	Approved Basic 05-126853 BP		2003 IRC	Plan: 9617-A-B T	2006
New	2-story sfr w/attached garage				2006
New	Split level sfr w/attached garage				2006
New	Two story SFR with attached Garage				2006
New	Two Story SFR with attached Garage				2006
New	40 x 70 2004 Champion				2006
New	Two-story SFR with attached garage - 2003 IRC				2006
New	3297 sq. ft. 2 story SFR with 1338 sq. ft. attached garage				2006
New	2-Story SFR w/attached 3 car garage.				2006
New	2-story w/unfinished basement				2006
New	One-story SFR	2003 IRC			2006
New	Two story SFR with attached garage				2006
New	Rambler style w/finished basement & garage				2006
New	Two story SFR with attached Garage				2006
New	Two-story SFR - 1997 UBC				2006
New	3308 sq ft 2-story single family residence with attached 821 sq ft three-car garage.				2006
New	Two-story SFR with attached garage - 2003 IRC				2006
New	1728 sq. ft. SFR with garage				2006
New	97 ft x 112 ft one story SFR with attached garage				2006
New	Approved Basic 06-100586 BP	2003 IRC	SFR w/finished daylight bsmt	Plan:	2006
New	Approved basic 06-129078 BP	2003 IRC	Plan# 2838	2 story with attached 3 car gara	2006
New	2-story sfr w/attached garage				2006
New	Two Story SFR with attached Garage				2006
New	Tri-level sfr with attached garage				2006
New	2-story SFR w/covered entry				2006
New	2 story SFR & covered porch w/ attached 3 car garage & storage above.				2006
New	Two story SFR with Semi-Finished Basement & attached Garage				2006
New	35 ft x 61 ft SFR with attached garage				2006
New	Two-story sfr with attached garage				2006
New	Two Stroy SFR with Attached Garage				2006
New	Rambler Style SFR - 1997 UBC				2006
New	Approved basic 06-127809 BP	2003 IRC	Plan# 1629	2-story sfr w/attached gara	2006
New	Approved basic 06-127809 BP	2003 IRC	Plan# 1629	2-story sfr w/attached gara	2006
New	Approved basic 06-127809 BP	2003 IRC	Plan# 1629	2-story sfr w/attached gara	2006
New	Two-story SFR - 2003 IRC		Plan: 1374		2006
New	2 story SFR w/ attchd 2 car garage				2006
New	Approved basic 06-102966 BP	2003 IRC	Plan # 2086	Split level entry w/attached ga	2006
New	Approved basic 06-102966 BP	2003 IRC	Plan # 2086	Split level entry w/attached ga	2006
New	Two-story sfr with garage				2006
New	Two-story SFR	2003 IRC			2006

Accessory Dwelling Units

Index # - File Name: 1.0022 - Single Family Dwellings Data\_Snohomish County.pdf

New	Approved Basic 05-126183BP	2003 IRC	Duplex w/attached garage	Plan:3847	2006
New	Approved Basic 05-126183BP	2003 IRC	Duplex w/attached garage	Plan:3847	2006
New	Approved Basic 05-129072BP	2003 IRC	Plan 3856 2 story Duplex w/attached garage		2006
New	2 story SFR w/attached garage	2003 IRC	Plan:1956		2006
New	Approved Basic 05-129072BP	2003 IRC	Plan 3856 2 story Duplex w/attached garage		2006
New	Approved Basic 05-126183BP	2003 IRC	Duplex w/attached garage	Plan:3847	2006
New	Approved Basic 05-129072BP	2003 IRC	Plan 3856 2 story Duplex w/attached garage		2006
New	Approved Basic 05-126183BP	2003 IRC	Duplex w/attached garage	Plan:3847	2006
New	Approved Basic 05-126183BP	2003 IRC	Duplex w/attached garage	Plan:3847	2006
New	Rambler w/attached garage				2006
New	Approved basic 05-128202 BP	2003 IRC	Plan: Newport A	2-story w/attached garage	2006
New	Approved basic 05-128203 BP	2003 IRC	Plan# Newport B	2-story w/finished bsmt & attached garage	2006
New	Approved basic 05-127478 BP	2003 IRC	Plan# Leren	2-story sfr w/attached garage	2006
New	Approved Basic 05-100637BP	2003 IRC	Plan:Ashford Day 2365		2006
New	Approved basic 05-127474 BP	2003 IRC	Plan # Quincy A	2-story sfr w/attached garage	2006
New	One-story SFR w/finished basement				2006
New	One-story SFR w/finished basement				2006
New	One-story SFR w/finished basement				2006
New	Approved basic 05-127476 BP	2003 IRC	Plan # Quincy B	2-story sfr w/attached garage	2006
New	Approved basic 05-127478 BP	2003 IRC	Plan# Leren	2-story sfr w/attached garage	2006
New	Approved basic 06-104069 BP	2003 IRC	Plan# Rochester	2-story sfr w/attached garage	2006
New	Approved basic 05-128203 BP	2003 IRC	Plan# Newport B	2-story w/finished bsmt & attached garage	2006
New	Approved basic 05-127474 BP	2003 IRC	Plan # Quincy A	2-story sfr w/attached garage	2006
New	Approved basic 05-128202 BP	2003 IRC	Plan: Newport A	2-story w/attached garage	2006
New	Approved Basic 05-126183BP	2003 IRC	Duplex w/attached garage	Plan:3847	2006
New	Approved Basic 05-126183BP	2003 IRC	Duplex w/attached garage	Plan:3847	2006
New	Two-story sfr with attached garage				2006
New	Approved Basic 06-128592BP	2003 IRC	Two-story SFR with attached garage	Plan: 2807	2006
New	Approved Basic 06-128592BP	2003 IRC	Two-story SFR with attached garage	Plan: 2807	2006
New	Pending Basic 06-133433-BP	2003 IRC	Plan # 2662	2-story SFR w/attached garage	2006
New	Approved Basic 06-128592BP	2003 IRC	Two-story SFR with attached garage	Plan: 2807	2006
New	Two-story sfr with attached garage				2006
New	Approved Basic 06-128595BP	2003 IRC	Two-story SFR with attached garage	Plan: 2807	2006
New	Approved Basic 05-123957BP	2003 IRC	Plan:1852	SFR w/finished basement & attached garage	2006
New	Approved Basic 05-123957BP	2003 IRC	Plan:1852	SFR w/finished basement & attached garage	2006
New	Approved Basic 05-123957BP	2003 IRC	Plan:1852	SFR w/finished basement & attached garage	2006
New	Approved Basic 06-134811 BP	2003 IRC	Plan: 2490G	Two-story SFR w/attached garage	2006
New	Approved Basic 06-134815 BP	2003 IRC	Plan: 2554H	Two-story SFR w/attached garage	2006
New	Approved Basic 06-134814 BP	2003 IRC	Plan # 2490H	2-story SFR w/ basement and attached garage	2006
New	Approved Basic 06-134812-BP	2003 IRC	Plan # 2554G	2-Story SFR w/basement and attached garage	2006
New	Approved Basic 05-123957BP	2003 IRC	Plan:1852	SFR w/finished basement & attached garage	2006
New	*Issued under tax roll # 005090-000-041-02*		2 story w/ attchd 3 car garage	Plan #2753	2006
New	*Issued under tax roll # 005090-000-041-02*		2 story w/ attached 3 car garage	Wyngate II plan	2006
New	*Issued under tax roll # 005090-000-041-02*		2 story SFR w/ attchd 3 car garage	Plan #2753	2006
New	Approved Basic 05-128211BP	2003 IRC	1 story SFR w/attached garage	Plan:2185	2006
New	Approved Basic 05-128208BP	2003 IRC	2 story SFR w/attached garage	Plan:2400	2006
New	Approved Basic 05-124079BP	2003 IRC	1 story SFR w/attached garage	Plan:1860	2006

Accessory Dwelling Units

Index # - File Name: 1.0022 - Single Family Dwellings Data\_Snohomish County.pdf

New	Approved Basic 05-124077BP	2003 IRC	1 story SFR w/attached garage	Plan:1625	2006
New	Approved Basic 05-128211BP	2003 IRC	1 story SFR w/attached garage	Plan:2185	2006
New	Approved Basic 05-124075BP	2003 IRC	1 story SFR w/attached garage	Plan:1857	2006
New	Approved Basic 05-124076BP	2003 IRC	1 story SFR w/attached garage	Plan:181.	2006
New	Approved Basic 05-128211BP	2003 IRC	1 story SFR w/attached garage	Plan:2185	2006
New	Approved Basic 05-124077BP	2003 IRC	1 story SFR w/attached garage	Plan:1625	2006
New	Approved Basic 05-128209BP	2003 IRC	2 story SFR w/attached garage	Plan:2155	2006
New	Approved Basic 05-124077BP	2003 IRC	1 story SFR w/attached garage	Plan:1625	2006
New	Approved Basic 05-124072BP	2003 IRC	2 story SFR w/attached garage	Plan:2092	2006
New	Approved Basic 05-124076BP	2003 IRC	1 story SFR w/attached garage	Plan:181.	2006
New	Approved Basic 06 127331 BP	Builders Plan: 1922	Two-story SFR	2003 IRC	2006
New	Approved Basic 05-128207BP	2003 IRC	2 story SFR w/attached garage	Plan:2591	2006
New	Approved Basic 05-128211BP	2003 IRC	1 story SFR w/attached garage	Plan:2185	2006
New	Approved Basic 05-124076BP	2003 IRC	1 story SFR w/attached garage	Plan:181.	2006
New	Approved Basic 05-128209BP	2003 IRC	2 story SFR w/attached garage	Plan:2155	2006
New	Approved Basic 05-124072BP	2003 IRC	2 story SFR w/attached garage	Plan:2092	2006
New	Approved Basic 05-124072BP	2003 IRC	2 story SFR w/attached garage	Plan:2092	2006
New	Approved Basic 05-124076BP	2003 IRC	1 story SFR w/attached garage	Plan:181.	2006
New	Approved Basic 05-128209BP	2003 IRC	2 story SFR w/attached garage	Plan:2155	2006
New	Approved Basic 05-124075BP	2003 IRC	1 story SFR w/attached garage	Plan:1857	2006
New	Approved Basic 05-124076BP	2003 IRC	1 story SFR w/attached garage	Plan:181.	2006
New	Two-story SFR with attached garage				2006
New	Approved basic 05-127055 BP	2003 IRC	Plan# Camden	2-story sfr w/attached garag	2006
New	Approved basic 05-127053 BP	2003 IRC	Plan# Covington	2-story sfr w/attached ga	2006
New	Approved basic 05-127474 BP	2003 IRC	Plan # Quincy A	2-story sfr w/attached gar	2006
New	Approved basic 05-127055 BP	2003 IRC	Plan# Camden	2-story sfr w/attached garag	2006
New	Approved basic 05-127478 BP	2003 IRC	Plan# Leren	2-story sfr w/attached garage	2006
New	Approved basic 05-127055 BP	2003 IRC	Plan# Camden	2-story sfr w/attached garag	2006
New	Approved basic 05-127053 BP	2003 IRC	Plan# Covington	2-story sfr w/attached ga	2006
New	Approved 05-127056 bp	2003 IRC	Plan# Brookfield	2-story sfr w/attached garag	2006
New	Approved basic 05-127055 BP	2003 IRC	Plan# Camden	2-story sfr w/attached garag	2006
New	Approved basic 05-127478 BP	2003 IRC	Plan# Leren	2-story sfr w/attached garage	2006
New	Approved basic 05-127476 BP	2003 IRC	Plan # Quincy B	2-story sfr w/attached gar	2006
New	Approved basic 05-127053 BP	2003 IRC	Plan# Covington	2-story sfr w/attached ga	2006
New	Approved 05-127056 bp	2003 IRC	Plan# Brookfield	2-story sfr w/attached garag	2006
New	Approved basic 05-127478 BP	2003 IRC	Plan# Leren	2-story sfr w/attached garage	2006
New	Approved basic 05-127053 BP	2003 IRC	Plan# Covington	2-story sfr w/attached ga	2006
New	Approved basic 05-127476 BP	2003 IRC	Plan # Quincy B	2-story sfr w/attached gar	2006
New	Approved basic 05-127478 BP	2003 IRC	Plan# Leren	2-story sfr w/attached garage	2006
New	Approved basic 05-127474 BP	2003 IRC	Plan # Quincy A	2-story sfr w/attached gar	2006
New	Approved basic 05-127053 BP	2003 IRC	Plan# Covington	2-story sfr w/attached ga	2006
New	Approved basic 05-127478 BP	2003 IRC	Plan# Leren	2-story sfr w/attached garage	2006
New	Approved Basic 06-101801 BP	2003 IRC	Plan: Blakely	Two-s	2006
New	Approved Basic 06-101807 BP	2003 IRC	Plan: Orcas	Two-stoi	2006
New	Approved Basic 06-101801 BP	2003 IRC	Plan: Blakely	Two-story sfr v	2006
New	Approved Basic 06-101812 BP	2003 IRC	Plan: Cypress	Two-s	2006
New	Approved Basic 06-101807 BP	2003 IRC	Plan: Orcas	Two-stoi	2006

Accessory Dwelling Units

Index # - File Name: 1.0022 - Single Family Dwellings Data\_Snohomish County.pdf

New	Approved Basic 06-101812 BP	2003 IRC	Plan: Cypress	Two-	2006
New	Approved Basic 06-101812 BP	2003 IRC	Plan: Cypress	Two-	2006
New	Approved Basic 06-101812 BP	2003 IRC	Plan: Cypress	Two-	2006
New	Approved basic 05-127054 BP	2003 IRC	Plan# Nantucket	2-story sfr w/attached gara	2006
New	Approved basic 05-127478 BP	2003 IRC	Plan# Leren	2-story sfr w/attached garage	2006
New	Approved basic 05-127474 BP	2003 IRC	Plan # Quincy A	2-story sfr w/attached gar	2006
New	Approved basic 05-127478 BP	2003 IRC	Plan# Leren	2-story sfr w/attached garage	2006
New	Approved basic 05-127053 BP	2003 IRC	Plan# Covington	2-story sfr w/attached ga	2006
New	Approved 05-127056 bp	2003 IRC	Plan# Brookfield	2-story sfr w/attached garag	2006
New	Approved basic 05-127054 BP	2003 IRC	Plan# Nantucket	2-story sfr w/attached gara	2006
New	Approved basic 05-127478 BP	2003 IRC	Plan# Leren	2-story sfr w/attached garage	2006
New	Approved basic 06-104069 BP	2003 IRC	Plan# Rochester	2-story sfr w/atta	2006
New	Approved basic 05-127478 BP	2003 IRC	Plan# Leren	2-story sfr w/attached garage	2006
New	Approved basic 06-104069 BP	2003 IRC	Plan# 2182	2-story sfr w/attache	2006
New	Approved basic 05-127862	2003 IRC	Plan # 2425	2-story sfr w/attached garage	2006
New	Approved Basic 06-131030-BP	2003 IRC	Plan No. 1440	1-story w/attached	2006
New	Two-story sfr with attached garage				2006
New	Approved Basic 06-129890-BP	2003 IRC	Plan # 1482	Split SFR w/attached gara	2006
New	Approved Basic 06-131030 BP	2003 IRC	Plan No. 1440	1-story w/attached	2006
New	Approved Basic 06-129890-BP	2003 IRC	Plan # 1482	Split SFR w/attached gara	2006
New	Approved Basic 06-132509BP	2003 IRC	Plan: 1482 Side Load	Split SFR w/attached gar	2006
New	40 x 48 2006 Fleetwood Barrington 7493K				
New	Approved Basic 06-102383BP	2003 IRC	2 story SFR w/attached garage		Plan:2 2006
New	Approved Basic #04-112452 BP	2003 IRC	Plan: 2736	2-story w/garage	2006
New	Approved Basic 06-101138BP	2003 IRC	2 story SFR w/attached garage		Plan: 2967 2006
New	Approved Basic 06-1-1139BP	2003 IRC	2 story SFR w/attached garage		Plan:2556 2006
New	Approved Basic 06-101137BP	2003 IRC	2 story SFR w/attached garage		Plan:2443 2006
New	2 story SFR w/attached garage		2003 IRC	Plan:3531	2006
New	Approved Basic 06-101138BP	2003 IRC	2 story SFR w/attached garage		Plan: 2967 2006
New	Approved Basic #04-112452 BP	Plan: 2736 2-story w/garage (2003 IRC/IBC)			2006
New	Approved Basic 06-101140BP	2003 IRC	2 story SFR w/attached garage		Plan:2461 2006
New	Approved Basic #04-112452 BP	Plan: 2736 2-story w/garage (2003 IRC/IBC)			2006
New	Approved Basic 06-101138BP	2003 IRC	2 story SFR w/attached garage		Plan: 2967 2006
New	Approved Basic #04-112452 BP	Plan: 2736 2-story w/garage (2003 IRC)			2006
New	Approved Basic 06-101138BP	2003 IRC	2 story SFR w/attached garage		Plan: 2967 2006
New	Approved Basic #04-112452 BP	Plan: 2736 2-story w/garage (2003 IRC)			2006
New	Approved Basic 06-102383BP	2003 IRC	2 story SFR w/attached garage		Plan:2 2006
New	Approved basic 06-103242 BP	2003 IRC	Plan# 2028	2-story sfr w/attached gara	2006
New	Approved Basic #04-112452 BP	Plan: 2736 2-story w/garage (2003 IRC/IBC)			2006
New	Approved Basic 06-102383BP	2003 IRC	2 story SFR w/attached garage		Plan:2 2006
New	Approved Basic #04-112452 BP	Plan: 2736 2-story w/garage (2003 IRC/IBC)			2006
New	Approved basic 06-126164 BP	2003 IRC	Plan# 2305	2-story sfr w/attached gara	2006
New	Approved Basic 06-101140BP	2003 IRC	2 story SFR w/attached garage		Plan:2461 2006
New	Approved basic 06-103242 BP	2003 IRC	Plan# 2028	2-story sfr w/attached gara	2006
New	Approved Basic 06-101138BP	2003 IRC	2 story SFR w/attached garage		Plan: 2967 2006
New	Approved basic 06-103242 BP	2003 IRC	Plan# 2028	2-story sfr w/attached gara	2006
New	Approved Basic #04-112448 BP	Plan: 2180 2-story w/garage			20 2006

Accessory Dwelling Units

Index # - File Name: 1.0022 - Single Family Dwellings Data\_Snohomish County.pdf

New	Approved basic 06-126164 BP	2003 IRC	Plan# 2305	2-story sfr w/attached garage	2006
New	Approved Basic 04-117358BP	2003 IRC	Plan:2206	2 story SFR w/attached garage	2006
New	Approved basic 06-103242 BP	2003 IRC	Plan# 2028	2-story sfr w/attached gara	2006
New	Approved Basic 06-101140BP	2003 IRC	Plan:2461	2 story SFR w/attached garage	2006
New	Approved basic 06-126164 BP	2003 IRC	Plan# 2305	2-story sfr w/attached gara	2006
New	Approved Basic 06-1-1139BP	2003 IRC	Plan:2556	2 story SFR w/attached garage	2006
New	Approved basic 06-103242 BP	2003 IRC	Plan# 2028	2-story sfr w/attached gara	2006
New	2005 Marlette Moblie Home				2006
New	Approved basic 05-123328 BP	2003 IRC	Plan#M1610A2F-3	2-story sfr w/attached	2006
New	Approved basic 05-123328 BP	2003 IRC	Plan#M1610A2F-3	2-story sfr w/attached	2006
New	Approved basic 05-123328 BP	2003 IRC	Plan#M1610A2F-3	2-story sfr w/attached	2006
New	Approved basic 05-123328 BP	2003 IRC	Plan#M1610A2F-3	2-story sfr w/attached	2006
New	Approved basic 05-123328 BP	2003 IRC	Plan#M1610A2F-3	2-story sfr w/attached	2006
New	Approved basic 05-123328 BP	2003 IRC	Plan#M1610A2F-3	2-story sfr w/attached	2006
New	Approved basic 05-123328 BP	2003 IRC	Plan#M1610A2F-3	2-story sfr w/attached	2006
New	Approved basic 05-123328 BP	2003 IRC	Plan#M1610A2F-3	2-story sfr w/attached	2006
New	Approved basic 05-123328 BP	2003 IRC	Plan#M1610A2F-3	2-story sfr w/attached	2006
New	Approved Basic 05-126785 BP			Plan: T2734-03A-N	2006
New	Approved basic 05-126160 BP	2003 IRC	Plan# 3036 B	2-story sfr w/attached ga	2006
New	Approved basic 05-125351 BP	2003 IRC	Plan# 3117 A	2-story sfr w/attached gar	2006
New	Approved basic 05-126160 BP	2003 IRC	Plan# 3036 B	2-story sfr w/attached ga	2006
New	Approved basic 05-126158 BP	2003IRC	Plan# 2700 A	2-story sfr w/attached g	2006
New	Approved basic 05-128452 BP	2003 IRC	Plan# 2440 BE	2-story sfr w/attached gar	2006
New	Approved Basic 04-120908BP	2003 IRC	Plan:2140C	2 story SFR w/attached garage	2006
New	Approved basic 05-125348 BP	2003 IRC	Plan# 2440 B	2-story sfr w/attached g	2006
New	Approved basic 05-127859 BP	2003 IRC	Plan # 2345	2-story sfr w/attached garage	2006
New	Approved basic 05-128013 BP	2003 IRC	Plan# 2590	2-story sfr w/attached gara	2006
New	Approved basic 05-127863 BP	2003 IRC	Plan# 2294	2-story sfr w/attached gara	2006
New	Approved basic 05-127862	2003 IRC	Plan # 2425	2-story sfr w/attached garage	2006
New	Approved basic 05-127863 BP	2003 IRC	Plan# 2294	2-story sfr w/attached gara	2006
New	Approved basic 05-128013 BP	2003 IRC	Plan# 2590	2-story sfr w/attached gara	2006
New	Approved basic 05-128017 BP	2003 IRC	Plan # 2283	2-story sfr w/attached gara	2006
New	Approved basic 05-128013 BP	2003 IRC	Plan# 2590	2-story sfr w/attached gara	2006
New	Approved basic 05-127862	2003 IRC	Plan # 2425	2-story sfr w/attached garage	2006
New	Approved basic 05-128013 BP	2003 IRC	Plan# 2590	2-story sfr w/attached gara	2006
New	Approved basic 05-127863 BP	2003 IRC	Plan# 2294	2-story sfr w/attached gara	2006
New	Approved basic 05-127863 BP	2003 IRC	Plan# 2294	2-story sfr w/attached gara	2006
New	Approved basic 05-127859 BP	2003 IRC	Plan # 2345	2-story sfr w/attached garage	2006
New	Approved basic 05-127863 BP	2003 IRC	Plan# 2294	2-story sfr w/attached gara	2006
New	Approved basic 05-127862	2003 IRC	Plan # 2425	2-story sfr w/attached garage	2006
New	Approved basic 05-127859 BP	2003 IRC	Plan # 2345	2-story sfr w/attached garage	2006
New	Approved basic 05-127863 BP	2003 IRC	Plan# 2294	2-story sfr w/attached gara	2006
New	Approved basic 05-127859 BP	2003 IRC	Plan # 2345	2-story sfr w/attached garage	2006
New	Approved basic 05-127863 BP	2003 IRC	Plan# 2294	2-story sfr w/attached gara	2006
New	Approved basic 05-127862	2003 IRC	Plan # 2425	2-story sfr w/attached garage	2006
New	Approved basic 05-127859 BP	2003 IRC	Plan # 2345	2-story sfr w/attached garage	2006
New	Approved basic 05-128017 BP	2003 IRC	Plan # 2283	2-story sfr w/attached gara	2006

Accessory Dwelling Units

Index # - File Name: 1.0022 - Single Family Dwellings Data\_Snohomish County.pdf

New	Approved basic 05-126160 BP	2003 IRC	Plan# 3036 B	2-story sfr w/attached ga	2006
New	Approved basic 05-126157 BP	2003 IRC	Plan# 2700 B	2-story sfr w/attached g	2006
New	Approved Basic 04-120908BP	2 story SFR w/attached garage	2003 IRC	Plan:2140C	2006
New	Approved basic 05-125348 BP	2003 IRC	Plan# 2440 B	2-story sfr w/attached g	2006
New	Approved Basic 04-120908BP	2 story SFR w/attached garage	2003 IRC	Plan:2140C	2006
New	Rambler style SFR w/covered deck/porch				2006
New	Two story SFR with attached Garage				2006
New	2-story sfr w/attached garage				2006
New	2-story sfr w/attached garage				2006
New	2-story sfr w/attached garage				2006
New	2-story sfr w/attached garage				2006
New	2-story sfr w/attached garage				2006
New	Two-story sfr with attached garage				2006
New	2-Story SFR w/attached garage.				2006
New	Approved Basic 05-100006BP	2003 IRC	Plan:2472A	2 story SFR w/attached garage	2006
New	Approved Basic 04-120905BP	2 story SFR w/attached garage	2003 IRC	Plan:2598	2006
New	Approved Basic 04-120909BP	2 story SFR w/attached garage	2003 IRC	Plan:2042C	2006
New	Approved Basic 05-100004BP	2 story SFR w/attached garage	2003 IRC	Plan:2042B	2006
New	Approved Basic 04-120910BP	2 story SFR w/attached garage	2003 IRC	Plan:2409A	2006
New	Approved Basic 04-120905BP	2 story SFR w/attached garage	2003 IRC	Plan:2598	2006
New	Approved Basic 04-120905BP	2 story SFR w/attached garage	2003 IRC	Plan:2598	2006
New	Approved Basic 05-100008BP	2 story SFR w/attached garage	2003 IRC	Plan:2472B	2006
New	Approved Basic 05-100006BP	2003 IRC	Plan:2472A	2 story SFR w/attached garage	2006
New	Approved Basic 05-100008BP	2 story SFR w/attached garage	2003 IRC	Plan:2472B	2006
New	Approved Basic 05-100006BP	2003 IRC	Plan:2472A	2 story SFR w/attached garage	2006
New	Approved Basic 04-120909BP	2 story SFR w/attached garage	2003 IRC	Plan:2042C	2006
New	Approved Basic 04-120912BP	2 story SFR w/attached garage	2003 IRC	Plan:2409B	2006
New	Approved Basic 04-120905BP	2 story SFR w/attached garage	2003 IRC	Plan:2598	2006
New	Approved Basic 04-120905BP	2 story SFR w/attached garage	2003 IRC	Plan:2598	2006
New	Approved Basic 04-120912BP	2 story SFR w/attached garage	2003 IRC	Plan:2409B	2006
New	Approved Basic 04-120905BP	2 story SFR w/attached garage	2003 IRC	Plan:2598	2006
New	Approved Basic 05-100004BP	2 story SFR w/attached garage	2003 IRC	Plan:2042B	2006
New	Approved Basic 04-120910BP	2 story SFR w/attached garage	2003 IRC	Plan:2409A	2006
New	Approved Basic 04-120905BP	2 story SFR w/attached garage	2003 IRC	Plan:2598	2006
New	Approved Basic 04-120905BP	2 story SFR w/attached garage	2003 IRC	Plan:2598	2006
New	Approved Basic 05-100008BP	2 story SFR w/attached garage	2003 IRC	Plan:2472B	2006
New	Rambler style SFR w/attached garage.				2006
New	Approved Basic 06-101856 BP		2003 IRC	Plan: 2846	2006
New	Approved basic 06-129611 BP	2003 IRC	Plan# 2567	2-story sfr w/attached gara	2006
New	Approved Basic 04-115896BP		Builders Plan #2271AC	2 Story w/ 3 Car	2006
New	Approved Basic 04-119744 BP	2 story SFR w/attached garage		2003 IRC Plan:2214	2006
New	Approved basic 06-129611 BP	2003 IRC	Plan# 2567	2-story sfr w/attached gara	2006
New	2 story SFR w/ basement & attchd 3 car garage				2006
New	2-story sfr w/attached garage				2006
New	Approved basic 06-102556 BP	2003 IRC	Plan# 2814 L	2-story SFR w/attached garage	2006
New	Approved Basic #05-118962 BP	2003 IRC	2 story SFR w/attached garage	Plan:M2625A3	2006

Accessory Dwelling Units

Index # - File Name: 1.0022 - Single Family Dwellings Data\_Snohomish County.pdf

New	Approved Basic 05-129393 BP	2003 IRC	2 story SFR w/attached Basic	Plan 17	2006
New	Approved Basic #05-126875 BP	2003 IRC	2 story SFR w/attached garage	Plan: Ashford	2006
New	Approved basic 06-101639 BP	2003 IRC	Plan# M2605A35-2R	2-story sfr w/attached g	2006
New	Aprvoved basic 06-101639 BP	2003 IRC	Plan# M2605A35-2R	2-story sfr w/attached g	2006
New	Approved Basic 05-128938BP	2003 IRC	Plan: 174-A The Alder	Two-story SFR	2006
New	Approved Basic #05-126875 BP	2003 IRC	2 story SFR w/attached garage	Plan: Ashford	2006
New	Approved Basic 05-129393 BP	2003 IRC	2 story SFR w/attached garage	Plan 1	2006
New	Approved Basic #05-118962 BP	2003 IRC	2 story SFR w/attached garage	Plan:M2625A3	2006
New	Approved basic 06-129638 BP	2003 IRC	Plan# 2213	2-story sfr w/attached gara	2006
New	Approved basic 06-102556 BP	2003 IRC	Plan# 2814 L	2-story SFR w/attached garag	2006
New	Approved Basic 06-101856 BP	2003 IRC	Plan: 2846	Two story SFR with attached Gar	2006
New	Approved Basic #05-118962 BP	2003 IRC	2 story SFR w/attached garage	Plan:M2625A3	2006
New	2-story sfr w/attached garage		Plan#41		2006
New	2-story sfr w/attahced garage		Plan 42		2006
New	Approved basic 06-101639 BP	2003 IRC	Plan# M2605A35-2R	2-story sfr w/attached g:	2006
New	2-story sfr w/attached garage		Plan# 44		2006
New	2-story sfr w/attached garage		Plan# 45		2006
New	2-story sfr w/attached garage		Plan# 46		2006
New	Approved Basic 05-127779BP	2003 IRC	2 story SFR w/attached garage	Plan:2278	2006
New	Approved Basic 06-102844BP	2003 IRC	2 story SFR w/attached garage	Plan:215	2006
New	Approved Basic 06-102716BP	2003 IRC	2 story SFRw/finished bsmt & garage	Plan	2006
New	Approved Basic 06-127031BP	2003 IRC	2 story SFR w/finished bsmt	Plan: 2125 bsmt Rev	2006
New	Approved Basic 06-102716BP	2003 IRC	2 story SFRw/finished bsmt & garage	Plan	2006
New	Approved Basic 06-127031BP	2003 IRC	2 story SFR w/finished bsmt	Plan: 2125 bsmt Rev	2006
New	Approved Basic 06-102716BP	2003 IRC	2 story SFRw/finished bsmt & garage	Plan	2006
New	Approved Basic 06-102716BP	2003 IRC	2 story SFRw/finished bsmt & garage	Plan	2006
New	Approved Basic 06-127031BP	2003 IRC	2 story SFR w/finished bsmt	Plan: 2125 bsmt Rev	2006
New	Approved Basic 06-102716BP	2003 IRC	2 story SFRw/finished bsmt & garage	Plan	2006
New	Approved Basic 06-127031BP	2003 IRC	2 story SFR w/finished bsmt & garage	Plan:2125 I	2006
New	Approved Basic 06-102716BP	2003 IRC	2 story SFRw/finished bsmt & garage	Plan	2006
New	Approved Basic 06-102719BP	2003 IRC	2 story SFR w/finished bsmt & garage	Plan:2125 I	2006
New	Approved Basic 06-102716BP	2003 IRC	2 story SFRw/finished bsmt & garage	Plan	2006
New	Approved Basic 06-102716BP	2003 IRC	2 story SFRw/finished bsmt & garage	Plan	2006
New	Approved Basic 06-102639BP	2003 IRC	2 story SFRw/attached garage	Plan:2248	2006
New	Approved Basic 06-102639BP	2003 IRC	2 story SFRw/attached garage	Plan:2248	2006
New	Approved Basic 06-102639BP	2003 IRC	2 story SFRw/attached garage	Plan:2248	2006
New	Approved basic 06-125932 BP	2003 IRC	Plan# 2248	2-story sfr w/attached gara	2006
New	Approved basic 06-125932 BP	2003 IRC	Plan# 2248	2-story sfr w/attached gara	2006
New	Approved basic 06-129645 BP	2003 IRC	Plan# 2254	2-story sfr w/attached garag	2006
New	Approved basic 05-129159 BP	2003 IRC	Plan# 3280	2-story sfr w/attached garage	2006
New	Approved basic 06-129638 BP	2003 IRC	Plan# 2213	2-story sfr w/attached gara	2006
New	Approved basic 05-129350 BP	2003 IRC	Plan# 2752 B	2-story sfr w/semfinished bsmt	2006
New	Approved basic 05-129159 BP	2003 IRC	Plan# 3280	2-story sfr w/attached garage	2006
New	Approved basic 06-129638 BP	2003 IRC	Plan# 2213	2-story sfr w/attached gara	2006
New	Approved basic 05-129350 BP	2003 IRC	Plan# 2752 B	2-story sfr w/semifinished bsmt	2006
New	Approved basic 06-102556 BP	2003 IRC	Plan# 2814 L	2-story SFR w/attached garag	2006



Accessory Dwelling Units

Index # - File Name: 1.0022 - Single Family Dwellings Data\_Snohomish County.pdf

New	Two-story SFR				2006
New	Approved Basic 05-116276BP	2003 IRC	Plan: 2870		2006
New	Approved Basic 04-116923BP	2 story SFR w/attached garage	2003 IRC	Plan:1631 - 2 story	2006
New	Approved Basic 05-128486BP	2003 IRC	2 story SFR w/attached garage	Plan:1933	2006
New	Approved Basic 05-127766BP	2003 IRC	2 story SFR w/attached garage	Plan:1865	2006
New	Approved Basic 05-128486BP	2003 IRC	2 story SFR w/attached garage	Plan:1933	2006
New	Approved Basic 05-127766BP	2003 IRC	2 story SFR w/attached garage	Plan:1865	2006
New	2-story sfr w/attached garage				2006
New	2-story sfr w/attached garage				2006
New	Approved Basic 05-128160BP	2003 IRC	2 story SFR w/attached garage	Plan:2487	2006
New	Approved Basic 05-128486BP	2003 IRC	2 story SFR w/attached garage	Plan:1933	2006
New	Approved Basic 05-128160BP	2003 IRC	2 story SFR w/attached garage	Plan:2487	2006
New	Approved Basic 05-128483BP	2003 IRC	2 story SFR w/attached garage	Plan:2052	2006
New	Approved Basic 05-128486BP	2003 IRC	2 story SFR w/attached garage	Plan:1933	2006
New	2-story sfr w/attached garage				2006
New	Approved Basic 05-128483BP	2003 IRC	2 story SFR w/attached garage	Plan:2052	2006
New	2-story sfr w/attached garage				2006
New	Approved Basic 05-128485BP	2003 IRC	2 story SFR w/attached garage	Plan:2171	2006
New	Approved Basic 05-127766BP	2003 IRC	2 story SFR w/attached garage	Plan:1865	2006
New	Approved Basic 05-127771BP	2003 IRC	2 story SFR w/attached garage	Plan:2337	2006
New	Approved Basic 05-128486BP	2003 IRC	2 story SFR w/attached garage	Plan:1933	2006
New	Approved Basic 05-128485BP	2003 IRC	2 story SFR w/attached garage	Plan:2171	2006
New	Approved Basic 05-128483BP	2003 IRC	2 story SFR w/attached garage	Plan:2052	2006
New	Approved Basic 05-128485BP	2003 IRC	2 story SFR w/attached garage	Plan:2171	2006
New	Approved Basic 05-128483BP	2003 IRC	2 story SFR w/attached garage	Plan:2052	2006
New	Approved Basic 05-128486BP	2003 IRC	2 story SFR w/attached garage	Plan:1933	2006
New	Approved Basic 05-128486BP	2003 IRC	2 story SFR w/attached garage	Plan:1933	2006
New	Approved Basic 05-128486BP	2003 IRC	2 story SFR w/attached garage	Plan:1933	2006
New	Approved Basic 05-127766BP	2003 IRC	2 story SFR w/attached garage	Plan:1865	2006
New	2-story sfr w/attached garage				2006
New	Approved Basic 06-103349BP	2003 IRC	2 sotry SFR w/attached garage	Plan:2645	2006
New	Approved Basic 05-128160BP	2003 IRC	2 story SFR w/attached garage	Plan:2487	2006
New	Approved Basic 05-128486BP	2003 IRC	2 story SFR w/attached garage	Plan:1933	2006
New	2-story sfr w/attached garage				2006
New	Approved Basic 05-128488BP	2003 IRC	2 story SFR w/attached garage	Plan:1965	2006
New	Approved Basic 05-128160BP	2003 IRC	2 story SFR w/attached garage	Plan:2487	2006
New	Approved Basic 05-128483BP	2003 IRC	2 story SFR w/attached garage	Plan:2052	2006
New	Approved Basic 04-116923BP	2 story SFR w/attached garage	2003 IRC	Plan:1631 - 2 story	2006
New	Approved Basic 05-128485BP	2003 IRC	2 story SFR w/attached garage	Plan:2171	2006
New	Approved Basic 05-128483BP	2003 IRC	2 story SFR w/attached garage	Plan:2052	2006
New	Approved Basic 04-120907BP	2 story SFR w/attached garage	2003 IRC	Plan:2140B	2006
New	2-Story over daylight basement.				2006
New	Approved basic 05-125349 BP	2003 IRC	Plan# 2440 A	2-story sfr w/attache	2006
New	Approved basic 05-125351 BP	2003 IRC	Plan# 3117 A	2-story sfr w/attached gar	2006
New	Approved Basic 05-126785 BP			Plan: T2734-03A-N	2006
New	Approved basic 05-128449 BP	2003 IRC	Plan# 2440 AE	2-story sfr w/attached g	2006
New	Approved Basic 04-120907BP	2 story SFR w/attached garage	2003 IRC	Plan: 214	2006

Accessory Dwelling Units

Index # - File Name: 1.0022 - Single Family Dwellings Data\_Snohomish County.pdf

New	Approved basic 05-125351 BP	2003 IRC	Plan# 3117 A	2-story sfr w/attached gar	2006
New	Approved Basic 04-120907BP	2 story SFR w/attached garage	2003 IRC	Plan:2140B	2006
New	Approved basic 05-125348 BP	2003 IRC	Plan# 2440 B	2-story sfr w/attached g	2006
New	Approved basic 05-128452 BP	2003 IRC	Plan# 2440 BE	2-story sfr w/attached gar	2006
New	Approved basic 05-125348 BP	2003 IRC	Plan# 2440 B	2-story sfr w/attached g	2006
New	Approved Basic 05-126785 BP			Plan: T2734-03A-N	2006
New	Approved basic 05-125351 BP	2003 IRC	Plan# 3117 A	2-story sfr w/attached gar	2006
New	Approved Basic 05-100008BP	2 story SFR w/attached garage	2003 IRC	Plan:2472B	2006
New	Approved Basic 04-120908BP	2 story SFR w/attached garage	2003 IRC	Plan:2140C	2006
New	Approved basic 05-128449 BP	2003 IRC	Plan# 2440 AE	2-story sfr w/attached g	2006
New	Approved basic 05-125349 BP	2003 IRC	Plan# 2440 A	2-story sfr w/attache	2006
New	Approved Basic 04-120908BP	2 story SFR w/attached garage	2003 IRC	Plan:2140C	2006
New	Approved basic 05-125349 BP	2003 IRC	Plan# 2440 A	2-story sfr w/attache	2006
New	Approved basic 05-125351 BP	2003 IRC	Plan# 3117 A	2-story sfr w/attached gar	2006
New	Approved Basic 05-126785 BP			Plan: T2734-03A-N	2006
New	Approved basic 05-125351 BP	2003 IRC	Plan# 3117 A	2-story sfr w/attached gar	2006
New	Approved basic 05-128452 BP	2003 IRC	Plan# 2440 BE	2-story sfr w/attached gar	2006
New	Approved Basic 04-120908BP	2 story SFR w/attached garage	2003 IRC	Plan:2140C	2006
New	Two-story SFR with attached garage -	2003 IRC			2006
New	One-story SFR	2003 IRC			2006
New	Two-story SFR with attached garage	2003 IRC	Plan: 2523		2006
New	Approved basic 06-128098 BP	2003 IRC	Plan# 1848 Bsmt	2-story sfr w/attached ga	2006
New	Approved Basic 05-127779BP	2003 IRC	2 story SFR w/attached garage	Plan:2278	2006
New	Approved Basic 06-100083BP	2003 IRC	2 story SFR w/attached garage	Plan:2140	2006
New	Approved Basic 06-102846BP	2003 IRC	2 story SFR w/attached garage	Plan:1848	2006
New	Approved Basic 05-127779BP	2003 IRC	2 story SFR w/attached garage	Plan:2278	2006
New	Approved basic 06-125931 BP	2003 IRC	Plan # 2125 Rev	2-story sfr w/attached gara	2006
New	Approved basic 06-125931 BP	2003 IRC	Plan # 2125 Rev	2-story sfr w/attache	2006
New	Approved Basic 04-116621BP	2 Story SFR w/attached garage	2003 IRC	Plan:1909	2006
New	Approved basic 06-129273 BP	2003 IRC	Plan # 1762	2-story sfr w/attached garage	2006
New	Approved basic 06-129274 BP	2003 IRC	Plan# 1854	2-story sfr w/attached garage	2006
New	1732 sq ft SFR with 747 sq ft attached garage.				2006
New	38 x 81 SFR with attached garage				2006
New	Rambler with attached garage				2006
New	1722 sf Rambler with attached garage				2006
New	One-story SFR	2003 IRC			2006
New	Two-story SFR with attached garage -	2003 IRC			2006
New	Approved Basic #04-115978BP		Plan R-2009-3	- PLEASE SEE LIZ BURNS. 4-25-06 Tw	2006
New	Approved Basic 05-125785BP	2003 IRC	Two story SFR with attached Garage	Plan:1935	2006
New	Approved Basic 05-126594BP	2003 IRC	2 story SFR w/attached garage	Plan:1775	2006
New	Approved Basic 05-125785BP	2003 IRC	Two story SFR with attached Garage	Plan:1935	2006
New	Approved Basic 05-125299BP	2003 IRC	2 story SFR w/attached garage	Plan:1906	2006
New	Rambler style SFR w/attached garage.				2006
New	Two story SFR with unfinished Basement and Attached Garage				2006
New	Approved Basic 04-116621BP	2 Story SFR w/attached garage	2003 IRC	Plan:1909	2006
New	Approved Basic 04-116621BP	2 Story SFR w/attached garage	2003 IRC	Plan:1909	2006
New	Approved basic 06-129273 BP	2003 IRC	Plan # 1762	2-story sfr w/attached garage	2006

Accessory Dwelling Units

Index # - File Name: 1.0022 - Single Family Dwellings Data\_Snohomish County.pdf

New	Approved Basic 04-116621BP	2 Story SFR w/attached garage	2003 IRC	Plan:1909	2006
New	Approved basic 06-129274 BP	2003 IRC	Plan# 1854	2-story sfr w/attached garage	2006
New	Approved basic 06-129274 BP	2003 IRC	Plan# 1854	2-story sfr w/attached garage	2006
New	Approved Basic 05-127779BP	2003 IRC	2 story SFR w/attached garage	Plan:2278	2006
New	Approved Basic 06-102844BP	2003 IRC	2 story SFR w/attached garage	Plan:215	2006
New	Approved Basic 05-127779BP	2003 IRC	2 story SFR w/attached garage	Plan:2278	2006
New	Approved Basic 06-102844BP	2003 IRC	2 story SFR w/attached garage	Plan:215	2006
New	Approved Basic 06-102846BP	2003 IRC	2 story SFR w/attached garage	Plan:1848	2006
New	Approved Basic 05-127779BP	2003 IRC	2 story SFR w/attached garage	Plan:2278	2006
New	Approved Basic 06-102846BP	2003 IRC	2 story SFR w/attached garage	Plan:1848	2006
New	Approved Basic 05-127779BP	2003 IRC	2 story SFR w/attached garage	Plan:2278	2006
New	Approved Basic 06-102846BP	2003 IRC	2 story SFR w/attached garage	Plan:1848	2006
New	Approved Basic 06-102844BP	2003 IRC	2 story SFR w/attached garage	Plan:215	2006
New	Approved Basic 05-127779BP	2003 IRC	2 story SFR w/attached garage	Plan:2278	2006
New	Approved Basic 05-127779BP	2003 IRC	2 story SFR w/attached garage	Plan:2278	2006
New	Approved Basic 06-102844BP	2003 IRC	2 story SFR w/attached garage	Plan:215	2006
New	Approved Basic 06-102846BP	2003 IRC	2 story SFR w/attached garage	Plan:1848	2006
New	Approved Basic 05-127779BP	2003 IRC	2 story SFR w/attached garage	Plan:2278	2006
New	Approved basic 06-126631 BP	2003 IRC	Plan# 2278 Alt	2-story sfr w/attached gara	2006
New	Approved Basic 06-102844BP	2003 IRC	2 story SFR w/attached garage	Plan:215	2006
New	Approved Basic 05-127779BP	2003 IRC	2 story SFR w/attached garage	Plan:2278	2006
New	Approved basic 06-126631 BP	2003 IRC	Plan# 2278 Alt	2-story sfr w/attached gara	2006
New	Approved basic 06-126631 BP	2003 IRC	Plan# 2278 Alt	2-story sfr w/attached gara	2006
New	Approved Basic 05-119584BP	2003 IRC	2 story SFR w/attached garage	Plan:3022A	2006
New	Approved Basic 05-123013BP	2003 IRC	2 story SFR w/attached garage	Plan:3914A	2006
New	Approved Basic 05-123011BP	2003 IRC	2 story SFR w/attached garage	Plan:3913B	2006
New	Approved Basic 05-119588BP	2003 IRC	2 story SFR w/attached garage	Plan:302	2006
New	Approved Basic 05-123018BP	2003 IRC	2 story SFR w/attached garage	Plan:39	2006
New	Approved Basic 05-119586BP	2003 IRC	2 story SFR w/attached garage	Plan:3022E	2006
New	Approved Basic 05-123013BP	2003 IRC	2 story SFR w/attached garage	Plan:3914A	2006
New	Approved Basic 05-123015BP	2003 IRC	2 story SFR w/attached garage	Plan:3914B	2006
New	Approved Basic 05-119592BP	2003 IRC	2 story SFR w/attached garage	Plan:3024B	2006
New	Approved Basic 05-1203020BP	2003 IRC	2 story SFR w/attached garage	Plan:3915B	2006
New	Approved Basic 05-119584BP	2003 IRC	2 story SFR w/attached garage	Plan:3022A	2006
New	Approved Basic 05-123010BP	2003 IRC	2 story SFR w/attached garage	Plan:3913A	2006
New	Approved Basic 05-119588BP	2003 IRC	2 story SFR w/attached garage	Plan:302	2006
New	Approved Basic 05-123015BP	2003 IRC	2 story SFR w/attached garage	Plan:3914B	2006
New	Approved Basic 05-123018BP	2003 IRC	2 story SFR w/attached garage	Plan:39	2006
New	Approved Basic 05-123011BP	2003 IRC	2 story SFR w/attached garage	Plan:3913B	2006
New	Approved Basic 05-123013BP	2003 IRC	2 story SFR w/attached garage	Plan:3914A	2006
New	Approved Basic 05-1203020BP	2003 IRC	2 story SFR w/attached garage	Plan:3915B	2006
New	Approved Basic 05-119591BP	2003 IRC	2 story SFR w/attached garage	Plan:302	2006
New	Approved Basic 05-123018BP	2003 IRC	2 story SFR w/attached garage	Plan:39	2006
New	Approved Basic 05-119592BP	2003 IRC	2 story SFR w/attached garage	Plan:3024B	2006
New	Approved Basic 05-119588BP	2003 IRC	2 story SFR w/attached garage	Plan:302	2006
New	Approved Basic 05-123015BP	2003 IRC	2 story SFR w/attached garage	Plan:3914B	2006
New	Approved Basic 05-1203020BP	2003 IRC	2 story SFR w/attached garage	Plan:3915B	2006

Accessory Dwelling Units

Index # - File Name: 1.0022 - Single Family Dwellings Data\_Snohomish County.pdf

New	Approved Basic 05-123013BP	2003 IRC	2 story SFR w/attached garage	Plan:3914A	2006
New	Approved Basic 05-123010BP	2003 IRC	2 story SFR w/attached garage	Plan:3913A	2006
New	Approved Basic 05-119590BP	2003 IRC	2 story SFR w/attached garage	Plan:3023A	2006
New	Approved Basic 05-123011BP	2003 IRC	2 story SFR w/attached garage	Plan:3913B	2006
New	Approved Basic 05-119586BP	2003 IRC	2 story SFR w/attached garage	Plan:3022E	2006
New	Approved Basic 05-123013BP	2003 IRC	2 story SFR w/attached garage	Plan:3914A	2006
New	Approved Basic 05-123010BP	2003 IRC	2 story SFR w/attached garage	Plan:3913A	2006
New	Approved Basic 06-101807 BP	2003 IRC		Plan: Orcas Two-story	2006
New	Approved Basic 06-101815 BP	2003 IRC		Plan: San Juan Two-story	2006
New	Approved Basic 06-101812 BP	2003 IRC		Plan: Cypress Two-story	2006
New	Approved Basic 06-101807 BP	2003 IRC		Plan: Orcas Two-story	2006
New	Approved Basic 06-101801 BP	2003 IRC		Plan: Blakely Two-story sfr w	2006
New	Approved Basic 06-101801 BP	2003 IRC		Plan: Blakely Two-story sfr w	2006
New	Approved Basic 06-101812 BP	2003 IRC		Plan: Cypress Two-story	2006
New	Approved Basic 06-101807 BP	2003 IRC		Plan: Orcas Two-story	2006
New	Approved Basic 06-101815 BP	2003 IRC		Plan: San Juan Two-story	2006
New	Approved Basic 06-101818 BP	2003 IRC		Plan: Lopez Two-story	2006
New	Approved Basic 06-101812 BP	2003 IRC		Plan: Cypress Two-story	2006
New	Approved Basic 06-101807 BP	2003 IRC		Plan: Orcas Two-story	2006
New	Approved Basic 06-101818 BP	2003 IRC		Plan: Lopez Two-story	2006
New	Approved Basic 06-101818 BP	2003 IRC		Plan: Lopez Two-story	2006
New	Approved Basic 06-101812 BP	2003 IRC		Plan: Cypress Two-story	2006
New	Approved Basic 06-101807 BP	2003 IRC		Plan: Orcas Two-story	2006
New	Approved Basic 06-101818 BP	2003 IRC		Plan: Lopez Two-story	2006
New	Approved Basic 06-101815 BP	2003 IRC		Plan: San Juan Two-story	2006
New	2272 sq ft Rambler with attached Garage				2006
New	Approved Basic 05-126094BP	2003 IRC	2 story SFR w/attached garage	Plan:2104H	2006
New	Approved Basic 06-135218BP	2003 IRC	Plan: 2319 2-story SFR with attached Gar		2006
New	Approved Basic 05-128207BP	2003 IRC	2 story SFR w/attached garage	Plan:2591	2006
New	Approved Basic 06 127329 BP	Builders Plan: 2211	Two-story SFR	2003 IRC	2006
New	Approved Basic 05-128205BP	2003 IRC	2 story SFR w/attached garage	Plan:2460	2006
New	Approved Basic 05-124076BP	2003 IRC	1 story SFR w/attached garage	Plan:181	2006
New	Approved Basic 05-128207BP	2003 IRC	2 story SFR w/attached garage	Plan:2591	2006
New	2-Story SFR w/attached garage.				2006
New	Two story SFR with unfinished Basement & attached Garage				2006
New	Approved Basic #05-101050 BP	2003 IRC	Plan #M2265C2F-0		2006
New	Approved Basic 05- 1000527BP				2006
New	Approved basic 06-125129 BP	2003 IRC	Plan# 2585 B	2-story sfr w/attached	2006
New	Approved Basic 06-127137BP	2003 IRC	Two-story SFR with attached garage	Plan: 1531C	2006
New	Approved Basic 06-104142BP	2003 IRC	2 story SFR w/attached garage	Plan:1721B	2006
New	Approved Basic 05-117086BP	2003IRC		Plan:1711C	2006
New	Approved basic 06-126164 BP	2003 IRC	Plan# 1418 A	2-story sfr w/attached garage	2006
New	Approved Basic 05-127689BP	2003 IRC	2 story SFR w/attached garage	Plan:1618	2006
New	Approved basic 06-125885 BP	2003 IRC	Plan# 2295 A	2-story sfr w/attached	2006
New	Approved Basic 04-116503BP		Plan: 1811B	Two-story SFR with attached	2006
New	Approved basic 06-126164 BP	2003 IRC	Plan# 1418 A	2-story sfr w/attached garage	2006
New	Approved Basic 05-127689BP	2003 IRC	2 story SFR w/attached garage	Plan:1618	2006

Accessory Dwelling Units

Index # - File Name: 1.0022 - Single Family Dwellings Data\_Snohomish County.pdf

New	Approved basic 06-126203 BP	2003 IRC	Plan# 1638 C	2-story sfr NO garage	2006
New	Approved Basic 05-126114BP	2003 IRC	2 story SFR w/attached garage	Plan:1127A	2006
New	Approved basic 06-126164 BP	2003 IRC	Plan# 1418 A	2-story sfr w/attached garage	2006
New	Approved Basic 06-104136BP	2003 IRC	2 story SFR (no garage)	Plan:11	2006
New	Approved basic 06-125677 BP	2003 IRC	Plan# 1618 B	2-story sfr w/attached gar	2006
New	Approved basic 06-125882 BP	2003 IRC	Plan# 1618 A	2-story sfr w/attached gara	2006
New	Approved basic 06-125342 BP	2003 IRC	Plan# 1319 A	2-story sfr w/attached	2006
New	Approved basic 06-103783 BP	2003 IRC	Plan# 2265 C	2-story sfr w/attached g	2006
New	Approved Basic 05-117988BP	2003 IRC	Plan:1811C		2006
New	Pending Basic 06-104157BP	2003 IRC	2 story SFR w/attached garage	Plan:1955A	2006
New	Approved basic 06-125344 BP	2003 IRC	Plan# 1329 C	2-story sfr no garage	2006
New	Approved Basic 05-117923BP	2003 IRC	Plan:2585A	2 story SFR w/attached gara	2006
New	Approved Basic 04-116503BP		Plan: 1811B	Two-story SFR with attached	2006
New	Approved Basic 04-116509BP		Plan: 1821B	Two-story SFR with attached	2006
New	Approved basic 06-125880 BP	2003 IRC	Plan # 1638 A	2-story sfr NO garage	2006
New	Approved Basic 05-126112BP	2003 IRC	2 story SFR w/attached garage	Plan:1418B	2006
New	Approved Basic 06-104139BP	2003 IRC	2 story SFR	Plan:1329A	2006
New	Approved Basic 06-126209BP	2003 IRC	Plan# 1328 A	2-story sfr NO garage	2006
New	Approved basic 06-127775 BP	2003 IRC	Plan# 1318 B	2-story sfr w/attached	2006
New	Approved basic 06-128047 BP	2003 IRC	Plan# 1017 A	2-story sfr w/attached ga	2006
New	Approved basic 06-126204 BP	2003 IRC	Plan# 1338 A	2-story sfr NO garage	2006
New	Approved Basic 05-126112BP	2003 IRC	2 story SFR w/attached garage	Plan:1418B	2006
New	Approved basic 06-125342 BP	2003 IRC	Plan# 1319 A	2-story sfr w/attached	2006
New	Approved Basic 06-104142BP	2003 IRC	2 story SFR w/attached garage	Plan:1721B	2006
New	Approved basic 06-126164 BP	2003 IRC	Plan# 1418 A	2-story sfr w/attached garage	2006
New	Approved basic 06-126205 BP	2003 IRC	Plan# 1328 A	2-story sfr NO garage	2006
New	2-Story SFR w/attached garage				2006
New	Approved basic 06-126164 BP	2003 IRC	Plan# 1418 A	2-story sfr w/attached garage	2006
New	Approved Basic 05-101187BP		2003 IRC	Plan:1721A	2006
New	Approved Basic 05-127689BP	2003 IRC	2 story SFR w/attached garage	Plan:1618	2006
New	Approved basic 06-128446 BP	2003 IRC	Plan# 1117 B	2-story sfr w/attached gara	2006
New	Approved Basic 05-126112BP	2003 IRC	2 story SFR w/attached garage	Plan:1418B	2006
New	Approved basic 06-130092 BP	2003 IRC	Plan# 1329 B	2-story sfr NO garage	2006
New	Approved basic 06-125342 BP	2003 IRC	Plan# 1319 A	2-story sfr w/attached	2006
New	Approved basic 06-126164 BP	2003 IRC	Plan# 1418 A	2-story sfr w/attached garage	2006
New	Approved basic 05-128452 BP	2003 IRC	Plan# 2440 BE	2-story sfr w/attached gar	2006
New	Approved Basic 04-120908BP	2 story SFR w/attached garage	2003 IRC	Plan:2140C	2006
New	Approved Basic 04-120907BP	2 story SFR w/attached garage	2003 IRC	Plan:2140B	2006
New	Two story SFR with attached Garage				2006
New	Approved Basic 06-128686BP	2003IRC	Two-story SFR with attached garage	Plan: 2	2006
New	Approved Basic 06-128696BP	2003 IRC	Two-story SFR with attached garage	Plan: 2396	2006
New	Approved Basic 06-128686BP	2003IRC	Two-story SFR with attached garage	Plan: 2	2006
New	Approved basic 06-127957 BP	2003 IRC	Plan# 2381	2-story sfr w/attached garage	2006
New	Approved Basic 06-128696BP	2003 IRC	Two-story SFR with attached garage	Plan: 2396	2006
New	Approved Basic 06-128686BP	2003IRC	Two-story SFR with attached garage	Plan: 2	2006
New	Approved Basic 06 126575 BP	2003 IRC	Builders Plan: 2052	Two-story SFR	2006
New	Approved Basic 06-128686BP	2003IRC	Two-story SFR with attached garage	Plan: 2	2006

Accessory Dwelling Units

Index # - File Name: 1.0022 - Single Family Dwellings Data\_Snohomish County.pdf

New	Approved basic 06-127957 BP	2003 IRC	Plan# 2381	2-story sfr w/attached garage	2006
New	Approved Basic 06-128696BP	2003 IRC	Two-story SFR with attached garage	Plan: 2396	2006
New	Approved Basic 06 126575 BP	2003 IRC	Builders Plan: 2052	Two-story SFR	2006
New	Approved Basic 06 126575 BP	2003 IRC	Builders Plan: 2052	Two-story SFR	2006
New	Approved basic 06-127777 BP	2003 IRC	Plan# 1027 A	2-story sfr w/attached garage	2006
New	Approved basic 06-127347 BP	2003 IRC	Plan# 1318 A	2-story sfr w/attached garage	2006
New	Approved basic 06-129520 BP	2003 IRC	Plan# 2733 B	2-story sfr w/attached garage	2006
New	Approved basic 06-126164 BP	2003 IRC	Plan# 1418 A	2-story sfr w/attached garage	2006
New	Approved Basic 05- 1000527BP				2006
New	Approved basic 06-127777 BP	2003 IRC	Plan# 1027 A	2-story sfr w/attached garage	2006
New	2-story sfr w/attached garage				2006
New	2-story sfr /attached garage				2006
New	Pending Basic 06-12689BP	Rambler with Attached Garage		Plan - Cascade View	2006
New	Rambler with attached garage				2006
New	Two-story SFR				2006
New	Approved Basic #04-115976BP		Please See Liz B. prior to issuance.		2006
New	Approved Basic 06-128686BP	2003IRC	Two-story SFR with attached garage	Plan: 2	2006
New	Approved Basic 06-128696BP	2003 IRC	Two-story SFR with attached garage	Plan: 2396	2006
New	Two-story SFR with attached garage - 2003 IRC				2006
New	Approved Basic 06-126462BP	Two-story SFR with 3-car garage - 2003 IRC		Plan: 303	2006
New	Approved Basic 06-126951BP	2003 IRC	Two-story SFR with 3-car garage	Plan: 2687	2006
New	Approved Basic #05-118418 BP	2003 IRC	Plan #2452	Two story SFR w/ Attached G	2006
New	Approved Basic 06-126476BP	Two-story SFR with 3-car garage 2003 IRC		Plan: 2777	2006
New	Approved Basic 06-126462BP	Two-story SFR with 3-car garage - 2003 IRC		Plan: 303	2006
New	Approved Basic 06-126476BP	Two-story SFR with 3-car garage 2003 IRC		Plan: 2777	2006
New	Approved Basic #05-118418 BP	2003 IRC	Plan #2452	Two story SFR w/ Attached G	2006
New	Approved Basic 06-126481BP	Two-story SFR with 3-car garage 2003 IRC		Plan: 26	2006
New	Approved Basic 06-126481BP	Two-story SFR with 3-car garage 2003 IRC		Plan: 26	2006
New	Approved Basic 06-125576BP	Rambler Style SFR - 2003 IRC		Plan: 1971	2006
New	Approved Basic 06-126467BP	Two-story SFR with 3-car garage 2003 IRC		Plan: 2863	2006
New	2 story sfr w/attached garage				2006
New	Approved Basic 06-126470BP	Two-story SFR with 3-car garage 2003IRC		Plan: 2958	2006
New	Approved Basic 06-126481BP	Two-story SFR with 3-car garage 2003 IRC		Plan: 26	2006
New	Approved Basic #05-118418 BP	2003 IRC	Plan #2452	Two story SFR w/ Attached G	2006
New	2-story w/finished basement & garage				2006
New	approved basic 06-103616 BP	2003 IRC	Plan# 2478G	2-story sfr w/attached garage	2006
New	Approved basic 06-103610 BP	2003 IRC	Plan# 2372 H 1	2-story sfr w/attached garage	2006
New	Approved basic 06-103607 BP	2003 IRC	Plan# 2478 H	2-story sfr w/attached garage	2006
New	Approved basic 06-126123 BP	2003 IRC	Plan # 2564G	2-story sfr w/attached garage	2006
New	Approved basic 06-126117 BP	2003 IRC	Plan # 2564H1	2-story sfr w/attached garage	2006
New	Approved Basic # 06-133461 BP	2003 IRC		Plan: 2130 Two story SFR	2006
New	Approved basic 06-126121 BP	2003 IRC	Plan # 2564H2	2-story sfr w/attached garage	2006
New	Approved basic 06-126117 BP	2003 IRC	Plan # 2564H1	2-story sfr w/attached garage	2006
New	Approved basic 06-103610 BP	2003 IRC	Plan# 2372 H 1	2-story sfr w/attached garage	2006
New	approved basic 06-103614 BP	2003 IRC	Plan #2372 H2	2-story sfr w/attached garage	2006
New	Approved basic 06-103607 BP	2003 IRC	Plan# 2478 H	2-story sfr w/attached garage	2006
New	Approved Basic 05-118698BP	2005 IRC	2 story SFR w/attached garage	Plan:BA	2006

Accessory Dwelling Units

Index # - File Name: 1.0022 - Single Family Dwellings Data\_Snohomish County.pdf

New	Approved Basic 05-118706BP	2003 IRC	2 story SFR w/attached garage	Plan:DA	2006
New	Approved Basic 05-118701BP	2003 IRC	2 story SFR w/attached garage	Plan:KA	2006
New	Approved Basic 04-118819BP	2003 IRC	2 story SFR w/attached garage	Plan:C4	2006
New	Approved Basic 05-122739BP	2003 IRC	3 story SFR w/attached garage	Plan:Preston	2006
New	Approved Basic 05-122739BP	2003 IRC	3 story SFR w/attached garage	Plan:Preston	2006
New	Approved Basic 05-118703BP	2003 IRC	2 story SFR w/attached garage	Plan:K-B	2006
New	Approved Basic 05-118707BP	2003 IRC	2 story SFR w/attached garage	Plan:KC	2006
New	Approved Basic 05-118703BP	2003 IRC	2 story SFR w/attached garage	Plan:K-B	2006
New	Approved Basic 05-122739BP	2003 IRC	3 story SFR w/attached garage	Plan:Preston	2006
New	Approved Basic 05-122739BP	2003 IRC	3 story SFR w/attached garage	Plan:Preston	2006
New	Approved Basic 05-118706BP	2003 IRC	2 story SFR w/attached garage	Plan:DA	2006
New	Approved Basic 05-118701BP	2003 IRC	2 story SFR w/attached garage	Plan:KA	2006
New	Applicant hs copy of final conducted by Rick Roberts 8/29/06 Approved Basic 04-118812BP SF				2006
New	Approved Basic 06-101605 BP	2003 IRC	Builder s Plan: Mt. Index - 2 (2 car/3 car) Tw		2006
New	Approved Basic 06-101194BP	2003 IRC	Rambler with attached garage	Plan:Pilchuck 2/E	2006
New	Approved Basic 06-101605 BP	2003 IRC	Builder s Plan: Mt. Index - 2 (2 car/3 car) Tw		2006
New	Approved Basic 06 101605 BP	2003 IRC	Builder s Plan: Mt. Index - 2 (2 ca		2006
New	Approved Basic 06-101605 BP	2003 IRC	Builder s Plan: Mt. Index - 2 (2 car/3 car) Tw		2006
New	Approved Basic 04-112103BP	2003 IRC	2 story SFR w/attached garage	Plan:Glacier Peak	2006
New	Approved Basic 04-112756BP	2003 IRC	2 story SFR w/attached garage	Plan: Mt Rainier	2006
New	Approved Basic 06-101605 BP	2003 IRC	Builder s Plan: Mt. Index - 2 (2 car/3 car) Tw		2006
New	Approved Basic 06 101605 BP	2003 IRC	Builder s Plan: Mt. Index - 2 (2 c		2006
New	Approved Basic 05-119760BP	2003 IRC	2 story SFR w/attached garage	Plan: Mt Adz	2006
New	Approved Basic 04-1120161 BP		Plan: Mt. Index 2 story sfr w/attached 3-ca		2006
New	Approved Basic 04-112108-BP		Rambler w/attached garage	2003-IRC	2006
New	Approved Basic 06-101194BP	2003 IRC	Rambler with attached garage	Plan:Pilchuck 3/B	2006
New	Approved Basic 04-112756BP	2003 IRC	2 story SFR w/attached garage	Plan: Mt Rainier	2006
New	Approved Basic 05-119760BP	2003 IRC	2 story SFR w/attached garage	Plan: Mt Adz	2006
New	Approved Basic 04-112103BP	2003 IRC	2 story SFR w/attached garage	Plan:Glacier Peak	2006
New	Approved Basic 06-101194BP	2003 IRC	Rambler with attached garage	Plan:Pilchuck 2/E	2006
New	Approved Basic 06-101194BP	2003 IRC	Rambler with attached garage	Plan:Pilchuck 2/B	2006
New	Approved Basic 04-112756BP	2003 IRC	2 story SFR w/attached garage	Plan: Mt Rainier	2006
New	Approved Basic 06-125770BP	2003 IRC	Two-story SFR with 3-car garage	Plan: Cascade #1	2006
New	Approved Basic 04-1120161 BP		Plan: Mt. Index 2 story sfr w/attached 3-ca		2006
New	Approved Basic 04-112107BP		2 story SFR w/attached car	2003 IRC Plan	2006
New	Approved Basic 06-101194BP	2003 IRC	Rambler with attached garage	Rambler: Pilchuck	2006
New	Approved Basic 06-101605 BP	2003 IRC	Builder s Plan: Mt. Index - 2 (2 car/3 car) Tw		2006
New	Approved Basic 06-101194BP	2003 IRC	Rambler with attached garage	Plan:Pilchuck 3/B	2006
New	Approved Basic 06-125770BP	2003 IRC	Two-story SFR with 3-car garage	Plan: Cascade #1	2006
New	Approved Basic 06-101605 BP	2003 IRC	Builder s Plan: Mt. Index - 2 (2 car/3 car) Tw		2006
New	Approved Basic 06-101194BP	2003 IRC	Rambler with attached garage	Plan:Pilchuck 2/E	2006
New	Approved Basic 04-112756BP	2003 IRC	2 story SFR w/attached garage	Plan: Mt Rainier	2006
New	Approved Basic 06-101849BP	2003 IRC		Plan: Dahlia 2553 Ra	2006
New	Approved Basic 06-102242BP	2003 IRC	Rambler style SFR with 3-car garage -	Plan: Wisteri	2006
New	2-Story SFR w/attached garage.				2006
New	Approved Basic 06-102242BP	2003 IRC	Rambler style SFR with 3-car garage -	Plan: Wisteri	2006
New	Approved Basic 06-101849BP	2003 IRC		Plan: Dahlia 2553 Ra	2006

Accessory Dwelling Units

Index # - File Name: 1.0022 - Single Family Dwellings Data\_Snohomish County.pdf

New	Approved Basic 06-101605 BP	2003 IRC	Builder s Plan: Mt. Index - 2 (2 car/3 car) Tw	2006
New	Approved Basic 06-125770BP	Two-story SFR with 3-car garage	2003 IRC Plan: Cascade #1	2006
New	Approved Basic 04-112756BP	2 story SFR w/attached garage	2003 IRC Plan: Mt Rainier	2006
New	Approved Basic 04-1120161 BP		Plan: Mt. Index 2 story sfr w/attached 3-ca	2006
New	Approved Basic 06-102242BP	Rambler style SFR with 3-car garage - 2003 IRC	Plan: Wisteri	2006
New	Approved Basic 06-101849BP	2003 IRC	Plan: Dahlia 2553 Ra	2006
New	1966 sq. ft. one story SFR with garage			2006
New	Two Story SFR with Attached Garage			2006
New	Approved Basic 06-102152-BP	2003 IRC	Rambler w/attached garage Plan	2006
New	Approved Basic 05-124338 BP	2003 IRC	Plan # 2454 Rambler w/ attached Garage	2006
New	Approved Basic 06-102154-BP	2003 IRC	2-Story SFR w/attached garage Plan:20	2006
New	Approved Basic 05-124338 BP	2003 IRC	Plan # 2454 Rambler w/ attached Garage	2006
New	Approved Basic 06-102154-BP	2003 IRC	2-Story SFR w/attached garage Plan:20	2006
New	Rambler with Attached Garage			2006
New	Approved Basic 06-100631 BP	2003 IRC	Plan # 2005 Rambler with a	2006
New	Approved Basic 05-124338 BP	2003 IRC	Plan # 2454 Rambler w/ attached Garage	2006
New	Approved Basic 05-124338 BP	2003 IRC	Plan # 2454 Rambler w/ attached Garage	2006
New	Approved Basic 06-102154-BP	2003 IRC	2-Story SFR w/attached garage Plan:2	2006
New	Approved Basic 04-1120161 BP		Plan: Mt. Index 2 story sfr w/attached 3-ca	2006
New	Approved Basic 04-112756BP	2 story SFR w/attached garage	2003 IRC Plan: Mt Rainier	2006
New	Approved Basic 06-125770BP	Two-story SFR with 3-car garage	2003 IRC Plan: Cascade #1	2006
New	Approved Basic 06-101605 BP	2003 IRC	Builder s Plan: Mt. Index - 2 (2 car/3 car) Tw	2006
New	Approved Basic 04-112107BP	2 story SFR w/attached car	2003 IRC Plan: Mt Ranier	2006
New	Approved Basic 04-1120161 BP		Plan: Mt. Index 2 story sfr w/attached 3-ca	2006
New	Approved Basic 06-101194 BP	2003 IRC	Rambler with attached garage Plan:Pilchuck 2/E	2006
New	Approved Basic 06-101605 BP	2003 IRC	Builder s Plan: Mt. Index - 2 (2 c	2006
New	Approved Basic 04-1120161 BP		Plan: Mt. Index 2 story sfr w/attached 3-ca	2006
New	Approved Basic 04-112108-BP	2003-IRC	Rambler w/attached garage Plan 99111/Mt. Pil	2006
New	Two Story SFR with Attached Garage			2006
New	2163sf rambler with attached garage - 2003 IRC			2006
New	Approved Basic 05-128525 BP	2003 IRC	2 story SFR w/attached garage Plan:245	2006
New	Approved Basic 05-124338 BP	2003 IRC	Plan # 2454 Rambler w/ attached Garage	2006
New	Approved Basic 05-124338 BP	2003 IRC	Plan # 2454 Rambler w/ attached Garage	2006
New	Approved Basic 06-102154-BP	2003 IRC	2-Story SFR w/attached garage Plan:20	2006
New	Approved Basic 06-102152-BP	2003 IRC	Rambler w/attached garage Plan	2006
New	Approved Basic 06-102154-BP	2003 IRC	2-Story SFR w/attached garage Plan:20	2006
New	Approved Basic 05-124338 BP	2003 IRC	Plan # 2454 Rambler w/ attached Garage	2006
New	Approved Basic 05-124338 BP	2003 IRC	Plan # 2454 Rambler w/ attached Garage	2006
New	Approved Basic 06-102154-BP	2003 IRC	2-Story SFR w/attached garage Plan:20	2006
New	Approved Basic 05-124338 BP	2003 IRC	Plan # 2454 Rambler w/ attached Garage	2006
New	Approved Basic 05-124338 BP	2003 IRC	Plan # 2454 Rambler w/ attached Garage	2006
New	Approved Basic 04-118845BP	2 story SFR w/attached garage	2003 IRC Plan:2294	2006
New	Approved basic 06-126631 BP	2003 IRC	Plan# 2278 Alt 2-story sfr w/attached gara	2006
New	Approved Basic 05-116898	2005 IRC	Plan:3114A	2006
New	Approved Basic 05-118278BP	2003 IRC	2 story SFR w/attached garage Plan:324	2006
New	Approved Basic 05-118204BP	2003 IRC	2 story SFR w/attached garage Plan:3	2006
New	Approved Basic 05-118883BP	2003 IRC	2 story SFR w/attached garage Plan:3240	2006



Accessory Dwelling Units

Index # - File Name: 1.0022 - Single Family Dwellings Data\_Snohomish County.pdf

New	Pending basic 06-125498 BP	2003 IRC	Plan# 3392	2-story sfr w/attached garag	2006
New	Two-story sfr with attached garage				2006
New	Approved Basic 06-102189BP	2003 IRC	2 story SFR w/attached garage	Plan:3392	2006
New	Approved Basic 06-127791BP	2003IRC	Two-story SFR with attached garage	Plan: 3431	2006
New	Approved Basic 06-101430BP	2003 IRC	2 story SFR w/attached garage	Plan:3397	2006
New	Approved Basic 06-102872BP	2003 IRC	2 story SFR w/attached garage	Plan:2969	2006
New	2-story sfr w/attached garage				2006
New	Approved Basic 06 127780BP	2003 IRC	2-story SFR with attached garage	Plan: 3027B	2006
New	Approved Basic 06-127780BP	2003 IRC	2-story SFR with attached garage	Plan: 3027B	2006
New	Approved Basic 06-102872BP	2003 IRC	2 story SFR w/attached garage	Plan:2969	2006
New	Approved Basic 06-127780BP	2003 IRC	2-story SFR with attached garage	Plan: 3027B	2006
New	Approved Basic 05-128525 BP	2003 IRC	2 story SFR w/attached garage	Plan:245	2006
New	Split level SFR w/ 2 car garage				2006
New	Approved Basic 06-101572BP	2003 IRC	2 story SFR w/attached garage	Plan:3439	2006
New	Approved Basic 06-101574BP	2003 IRC	2 story SFR w/attached garage	Plan:3397	2006
New	Approved Basic 06-101761BP	2003 IRC	2 story SFR w/attached garage	Plan:3397	2006
New	Approved Basic 06-101430BP	2003 IRC	2 story SFR w/attached garage	Plan:3397	2006
New	Approved Basic 06-101761BP	2003 IRC	2 story SFR w/attached garage	Plan:3397	2006
New	Approved Basic 06-101430BP	2003 IRC	2 story SFR w/attached garage	Plan:3397	2006
New	Approved Basic 06-101572BP	2003 IRC	2 story SFR w/attached garage	Plan:3439	2006
New	Approved Basic 06-101761BP	2003 IRC	2 story SFR w/attached garage	Plan:3397	2006
New	Approved Basic 06-101572BP	2003 IRC	2 story SFR w/attached garage	Plan:3439	2006
New	Approved basic 06-132170 BP	2003 IRC	Plan# 2911	2-story sfr w/attached garage	2006
New	Approved Basic 04-120167BP	2 story SFR w/attached garage	2003 IRC	Plan:2597	2006
New	Approved Basic 04-116621BP	2 Story SFR w/attached garage	2003 IRC	Plan:1909	2006
New	Approved Basic 04-116621BP	2 Story SFR w/attached garage	2003 IRC	Plan:1909	2006
New	Approved Basic 04-116513BP		Plan: 2421 A & B	Two-story SFR with atta	2006
New	Approved Basic 05-123442BP	2003 IRC	2 story SFR w/attached garage	Plan:3531C	2006
New	Approved Basic 05-117923BP	2003 IRC	Plan:2585A	2 story SFR w/attached gara	2006
New	Approved Basic 06-133259BP	2003 IRC	Two-story SFR with attached garage	Plan: 2075 A	2006
New	Approved Basic 05-127365BP	2003 IRC	2 story SFR w/attached garage	Plan:3131A & B	2006
New	Approved Basic 05-120007BP	2003 IRC	2 story SFR w/attached garage	Plan:3531B	2006
New	Approved Basic 05-127365BP	2003 IRC	2 story SFR w/attached garage	Plan:3131A & B	2006
New	Approved Basic 05-121678BP	2003 IRC	2 story SFR w/attached garage	Plan:241	2006
New	Approved Basic 04-116513BP		Plan: 2421 A & B	Two-story SFR with attached two-car garag	2006
New	Approved Basic 04-120594BP	2 story SFR w/attached garage	2003 IRC	Plan:2011A	2006
New	Approved Basic 05-118591BP	2003 IRC	2 story SFR w/attached garage	Plan:2011	2006
New	Approved Basic 06-132948BP	2003 IRC	Two-Story SFR with attached garage	Plan: 3531A	2006
New	Approved Basic 04-116513BP		Plan: 2421 A & B	Two-story SFR with atta	2006
New	Approved Basic 05-127365BP	2003 IRC	2 story SFR w/attached garage	Plan:3131A & B	2006
New	Approved Basic 04-120594BP	2 story SFR w/attached garage	2003 IRC	Plan:2011A	2006
New	Approved basic 06-131452 BP	2003 IRC	Plan# 2055 A	2-story sfr w/attached gar	2006
New	Approved basic 06-103783 BP	2003 IRC	Plan# 2265 C	2-story sfr w/attached g	2006
New	Approved basic 06-131899 BP	2003 IRC	Plan# 2065 A	2-story sfr w/attached gar	2006
New	Approved Basic 04-116517BP		Plan: 2221 B	Two-story SFR with attached gara	2006
New	Approved basic 06-131903 BP	2003 IRC	Plan# 2065 B	2-story sfr w/attached garag	2006
New	Approved basic 06-131899 BP	2003 IRC	Plan# 2065 A	2-story sfr w/attached gar	2006

Accessory Dwelling Units

Index # - File Name: 1.0022 - Single Family Dwellings Data\_Snohomish County.pdf

New	Approved	Basic 05-123442BP	2003 IRC	2 story SFR w/attached garage	Plan:3531C	2006
New	Approved	basic 06-130094 BP	2003 IRC	Plan# 3531 A	2-story sfr w/attached gara	2006
New	Approved	basic 06-129522 BP	2003 IRC	Plan# 2265 A	2-story sfr w/attached	2006
New	Approved	basic 06-130641 RK	2003 IRC	Plan# 3027 (E)	2-story sfr w/attache	2006
New	Approved	Basic 05-116898	2005 IRC		Plan:3114A	2006
New	Approved	basic 06-126609 BP	2003 IRC	Plan# 3044 A	2-story sfr w/attached g	2006
New	Approved	Basic 05-118278BP	2003 IRC	2 story SFR w/attached garage	Plan:324	2006
New	Approved	Basic 06-103500BP	2003 IRC	2 story SFR w/attached garage	Plan:3439	2006
New	Approved	Basic 06-101761BP	2003 IRC	2 story SFR w/attatched garage	Plan:3397	2006
New	Approved	Basic 06-101574BP	2003 IRC	2 story SFR w/attached garage	Plan:3397	2006
New	Approved	Basic 05-125684BP	2003 IRC	2 story SFR w/attached garage	Plan:3027A	2006
New	Approved	Basic 05-118204BP	2003 IRC	2 story SFR w/attached garage	Plan:3	2006
New	Approved	basic 06-126609 BP	2003 IRC	Plan# 3044 A	2-story sfr w/attached g	2006
New	Approved	Basic 05-118284BP	2003 IRC	2 story SFR w/attached garage	Plan:3027B	2006
New	Approved	Basic 05-116898	2005 IRC		Plan:3114A	2006
New	Approved	Basic 05-118204BP	2003 IRC	2 story SFR w/attached garage	Plan:3	2006
New	Approved	basic 06-130641 RK	2003 IRC	Plan# 3027 (E)	2-story sfr w/attache	2006
New	Approved	Basic 05- 124155BP	2003 IRC	2 story SFR w/attached garage	Plan:3114B	2006
New	Approved	Basic 05-118204BP	2003 IRC	2 story SFR w/attached garage	Plan:3	2006
New	Approved	basic 06-126609 BP	2003 IRC	Plan# 3044 A	2-story sfr w/attached gar:	2006
New	Approved	Basic 06-101572BP	2003 IRC	2 story SFR w/attached garage	Plan:3439	2006
New	Approved	Basic 06-101430BP	2003 IRC	2 story SFR w/attached garage	Plan:3397	2006
New	Approved	Basic 05-120468BP	2003 IRC	2 story SFR w/attached garage	Plan:3027B	2006
New	Approved	Basic 05-120468BP	2003 IRC	2 story SFR w/attached garage	Plan:3027B	2006
New	Approved	Basic 05-116898	2005 IRC		Plan:3114A	2006
New	Approved	Basic 05-118284BP	2003 IRC	2 story SFR w/attached garage	Plan:3027B	2006
New	Approved	Basic 06-101430BP	2003 IRC	2 story SFR w/attached garage	Plan:3397	2006
New	Two-story SFR with attached garage - 2003 IRC					2006
New	Approved	Basic 06-101572BP	2003 IRC	2 story SFR w/attached garage	Plan:3439	2006
New	Approved	basic 06-134213 BP	2003 IRC	Plan# 3027-E	2-story sft w/attached garag	2006
New	Approved	Basic 05-120468BP	2003 IRC	2 story SFR w/attached garage	Plan:3027B	2006
New	Approved	basic 06-134213 BP	2003 IRC	Plan# 3027-E	2-story sft w/attached garag	2006
New	Approved	basic 06-130643 BP	2003 IRC	Plan# 3027 (C)	2-story sfr w/attached	2006
New	Approved	Basic 05-120468BP	2003 IRC	2 story SFR w/attached garage	Plan:3027B	2006
New	Approved	Basic 05-118204BP	2003 IRC	2 story SFR w/attached garage	Plan:3	2006
New	Approved	Basic 05-120468BP	2003 IRC	2 story SFR w/attached garage	Plan:3027B	2006
New	Approved	Basic 04-120167BP	2 story SFR w/attached garage	2003 IRC	Plan:2597	2006
New	Approved	Basic 05-128525 BP	2003 IRC	2 story SFR w/attached garage	Plan:245	2006
New	Approved	Basic 06-127032BP	2003 IRC	2 story SFR w/attached garage	Plan:2323 Revised	2006
New	Approved	Basic 05-128525 BP	2003 IRC	2 story SFR w/attached garage	Plan:245	2006
New	Approved	Basic 06-127032BP	2003 IRC	2 story SFR w/attached garage	Plan:2323 Revised	2006
New	Approved	Basic 05-128525 BP	2003 IRC	2 story SFR w/attached garage	Plan:245	2006
New	Approved	Basic 04-120167BP	2 story SFR w/attached garage	2003 IRC	Plan:2597	2006
New	Approved	Basic 05-128525 BP	2003 IRC	2 story SFR w/attached garage	Plan:245	2006
New	Approved	Basic 04-115367BP	2 story SFR w/attached garage	2003 IRC	Plan:1932 ALT	2006
New	Approved	Basic 04-120167BP	2 story SFR w/attached garage	2003 IRC	Plan:2597	2006
New	Approved	Basic 05-128525 BP	2003 IRC	2 story SFR w/attached garage	Plan:245	2006

Accessory Dwelling Units

Index # - File Name: 1.0022 - Single Family Dwellings Data\_Snohomish County.pdf

New	Three story SFR with attached Garage				2006
New	Rambler style w/semi-finished basement and garage				2006
New	2645sf rambler with 691sf attached garage - 2003 IRC				2006
New	Approved Basic 04-120167BP	2 story SFR w/attached garage	2003 IRC	Plan:2597	2006
New	Approved Basic 04-115367BP	2 story SFR w/attached garage	2003 IRC	Plan:1932 ALT	2006
New	Approved Basic 04-120167BP	2 story SFR w/attached garage	2003 IRC	Plan:2597	2006
New	Approved Basic 04-115367BP	2 story SFR w/attached garage	2003 IRC	Plan:1932 ALT	2006
New	Approved Basic 05-128525 BP	2003 IRC	2 story SFR w/attached garage	Plan:245	2006
New	Approved Basic 04-115367BP	2 story SFR w/attached garage	2003 IRC	Plan:1932 ALT	2006
New	Approved basic 06-126609 BP	2003 IRC	Plan# 3044 A	2-story sfr w/attached g	2006
New	Approved Basic 05-118204BP	2003 IRC	2 story SFR w/attached garage	Plan:3	2006
New	Approved Basic 06-127791BP	2003IRC	Two-story SFR with attached garage	Plan: 34	2006
New	Approved Basic 06-101574BP	2003 IRC	2 story SFR w/attached garage	Plan:3397	2006
New	Approved Basic 04-120026 BP	rambler style w/3 car garage	2003 IRC	Plan: The Ric	2006
New	Approved Basic 04-120024	Plan Northridge	rambler style w/3 car garage	- 2003 IRC	2006
New	Approved Basic 06-101735 BP	2003 IRC	Plan: The Appleton	Two-stc	2006
New	EXPIRED WITHOUT COUNTY APPROVAL TO USE OR OCCUPY. SENT TO MICROFICHE. 5/9/08 App				2006
New	Approved Basic 04-116274BP	2003 IRC	Plan:The HillcrestT		2006
New	Approved BASIC 04-113472-BP		Bldr s. Plan 2197	Rambler Style SFR - 2003-IR	2006
New	Approved Basic 06-102459 BP	2003 IRC	2-story w/garage	Plan:2680	2006
New	Approved Basic 06-127032BP	2003 IRC	2 story SFR w/attached garage	Plan:2323 Revised	2006
New	Approved Basic 04-116274BP	2003 IRC	Plan:The HillcrestT		2006
New	Approved Basic 04-120026 BP	rambler style w/3 car garage	2003 IRC	Plan: The Ric	2006
New	Approved Basic 06-101858 BP	2003 IRC	Plan: The Appleton 2	Two-si	2006
New	Approved Basic #06-129185 BP	2003 IRC	Plan: 2095	2-story SFR w/attached Garage	2006
New	Approved Basic 06-125106BP	2003 IRC	Plan: 2420		2006
New	Approved Basic 06-125106BP	2003 IRC	Plan: 2420		2006
New	Approved Basic 06-125106BP	2003 IRC	Plan: 2420		2006
New	Approved Basic 06-125106BP	2003 IRC	Plan: 2420		2006
New	Approved Basic 06-125106BP	2003 IRC	Plan: 2420		2006
New	Approved Basic 06-125106BP	2003 IRC	Plan: 2420		2006
New	Pending Basic 06-127259BP	2003IRC	Two-story SFR with attached garage	Plan: 214	2006
New	Approved Basic 06-127264BP	2003 IRC	2-story SFR with attached garage	Plan 246	2006
New	Approved Basic 06-127264BP	2003 IRC	2-story SFR with attached garage	Plan 246	2006
New	Approved Basic 06-127264BP	2003 IRC	2-story SFR with attached garage	Plan 246	2006
New	Approved Basic 06-127264BP	2003 IRC	2-story SFR with attached garage	Plan 246	2006
New	Approved Basic 06-127259BP	2003IRC	Two-story SFR with attached garage	Plan: 21	2006
New	Approved Basic 05-122829BP	2003 IRC	2 story SFR w/attached garage	Plan:1809	2006
New	Approved Basic 06-127259BP	2003IRC	Two-story SFR with attached garage	Plan: 21	2006
New	Approved Basic 06-127264BP	2003 IRC	2-story SFR with attached garage	Plan 246	2006
New	Approved Basic 04-120167BP	2 story SFR w/attached garage	2003 IRC	Plan:2597	2006
New	Approved Basic 05-128525 BP	2003 IRC	2 story SFR w/attached garage	Plan:245	2006
New	Approved Basic 04-115367BP	2 story SFR w/attached garage	2003 IRC	Plan:1932 ALT	2006
New	Approved Basic 06-127032BP	2003 IRC	2 story SFR w/attached garage	Plan:2323 Revised	2006
New	Approved Basic 04-120167BP	2 story SFR w/attached garage	2003 IRC	Plan:2597	2006
New	Approved basic 06-132321 BP	2003 IRC	Plan# 2420	2-story sfr w/attached garage	2006
New	Approved Basic #06-129185 BP	2003 IRC	Plan: 2095	2- story SFR w/attached (	2006

Accessory Dwelling Units

Index # - File Name: 1.0022 - Single Family Dwellings Data\_Snohomish County.pdf

New	Approved Basic 06-127264BP	2003 IRC	2-story SFR with attached garage	Plan 246	2006
New	Approved Basic 06-127264BP	2003 IRC	2-story SFR with attached garage	Plan 246	2006
New	Approved Basic 06-127264BP	2003 IRC	2-story SFR with attached garage	Plan 246	2006
New	Approved Basic 06-127259BP	2003IRC	Two-story SFR with attached garage	Plan: 21	2006
New	Approved Basic 06-125675BP		Two Story SFR with Attached Garage	Plan 2965	2006
New	Approved Basic #06-100618	2003 IRC		Plan: 2885 Two st	2006
New	Approved Basic #06-100618	2003 IRC		Plan: 2885 Two st	2006
New	Approved Basic 06-125675BP		Two Story SFR with Attached Garage	Plan 2965	2006
New	Approved Basic #06-129185 BP	2003 IRC	Plan: 2095	2- story SFR w/attached (	2006
New	Approved Basic 06-127264BP	2003 IRC	2-story SFR with attached garage	Plan 2469	2006
New	Approved Basic 06-127264BP	2003 IRC	2-story SFR with attached garage	Plan 246	2006
New	Approved Basic 06-127264BP	2003 IRC	2-story SFR with attached garage	Plan 246	2006
New	Approved Basic 06-101137BP	2003 IRC	2 story SFR w/attached garage	Plan:2443	2006
New	Approved Basic 06-1-1139BP	2003 IRC	2 story SFR w/attached garage	Plan:2556	2006
New	Approved basic 06-125198 BP	2003 IRC	Plan# 2736	2-story sfr w/attached garage	2006
New	Approved Basic 06-101137BP	2003 IRC	2 story SFR w/attached garage	Plan:2443	2006
New	Two-story single family residence with attached garage				2006
New	Approved Basic 06-1-1139BP	2003 IRC	2 story SFR w/attached garage	Plan:2556	2006
New	Approved Basic 06-101138BP	2003 IRC	2 story SFR w/attached garage	Plan: 2967	2006
New	Approved basic 06-125198 BP	2003 IRC	Plan# 2736	2-story sfr w/attached garage	2006
New	Approved basic 06-126164 BP	2003 IRC	Plan# 2305	2-story sfr w/attached gara	2006
New	Approved basic 06-126542 BP	2003 IRC	Plan # 2119	2-story sfr w/attached gara	2006
New	Approved basic 06-126164 BP	2003 IRC	Plan# 2305	2-story sfr w/attached gara	2006
New	Approved basic 06-126542 BP	2003 IRC	Plan # 2119	2-story sfr w/attached gara	2006
New	Approved basic 06-125198 BP	2003 IRC	Plan# 2736	2-story sfr w/attached garage	2006
New	Approved Basic 06-101138BP	2003 IRC	2 story SFR w/attached garage	Plan: 2967	2006
New	Approved basic 06-130291	2003 IRC	Plan# 3531	2-story sfr w/attached gara	2006
New	Approved Basic 06-101138BP	2003 IRC	2 story SFR w/attached garage	Plan: 2967	2006
New	Approved Basic 06-101138BP	2003 IRC	2 story SFR w/attached garage	Plan: 2967	2006
New	Approved Basic 06-101140BP	2003 IRC	2 story SFR w/attached garage	Plan:2461	2006
New	Approved basic 06-130291 BP	2003 IRC	Plan# 3531	2-story sfr w/attached gi	2006
New	Approved basic 06-125198 BP	2003 IRC	Plan# 2736	2-story sfr w/attached garage	2006
New	Approved Basic 06-101137BP	2003 IRC	2 story SFR w/attached garage	Plan:2443	2006
New	Approved basic 06-126542 BP	2003 IRC	Plan # 2119	2-story sfr w/attached garage	2006
New	Approved basic 06-126164 BP	2003 IRC	Plan# 2305	2-story sfr w/attached gara	2006
New	2-story sfr w/attached garage				2006
New	Approved basic 06-126164 BP	2003 IRC	Plan# 2305	2-story sfr w/attached gara	2006
New	Approved basic 06-126542 BP	2003 IRC	Plan # 2119	2-story sfr w/attached gara	2006
New	Approved basic 06-125198 BP	2003 IRC	Plan# 2736	2-story sfr w/attached garage	2006
New	Approved basic 06-126164 BP	2003 IRC	Plan# 2305	2-story sfr w/attached gara	2006
New	Approved basic 06-130291 BP	2003 IRC	Plan# 3531	2-story sfr w/attached gi	2006
New	Approved Basic 06-101138BP	2003 IRC	2 story SFR w/attached garage	Plan: 2967	2006
New	Split entry sfr w/attached garage				2006
New	Approved Basic 06-101138BP	2003 IRC	2 story SFR w/attached garage	Plan: 2967	2006
New	Approved Basic 06-101137BP	2003 IRC	2 story SFR w/attached garage	Plan:2443	2006
New	Approved basic 06-125198 BP	2003 IRC	Plan# 2736	2-story sfr w/attached garage	2006
New	Two story SFR with attached Garage				2006

Accessory Dwelling Units

Index # - File Name: 1.0022 - Single Family Dwellings Data\_Snohomish County.pdf

New	Approved basic 06-126164 BP	2003 IRC	Plan# 2305	2-story sfr w/attached gara	2006
New	Approved basic 06-126542 BP	2003 IRC	Plan # 2119	2-story sfr w/attached gara	2006
New	2 story SFR w/ atchd 3 car garage				2006
New	Approved Basic 04-120167BP	2 story SFR w/attached garage	2003 IRC	Plan:2597	2006
New	Approved Basic 04-116621BP	2 Story SFR w/attached garage	2003 IRC	Plan:1909	2006
New	Approved Basic 05-116799BP	2003 IRC		Plan:2597 3 Car	2006
New	Approved Basic 04-120167BP	2 story SFR w/attached garage	2003 IRC	Plan:2597	2006
New	Approved Basic 04-120167BP	2 story SFR w/attached garage	2003 IRC	Plan:2597	2006
New	Approved Basic 05-128525 BP	2003 IRC	2 story SFR w/attached garage	Plan:245	2006
New	Approved basic 06-126631 BP	2003 IRC	Plan# 2278 Alt	2-story sfr w/attached gara	2006
New	Approved basic 06-126631 BP	2003 IRC	Plan# 2278 Alt	2-story sfr w/attached gara	2006
New	Approved Basic 04-118845BP	2 story SFR w/attached garage	2003 IRC	Plan:2294	2006
New	Approved basic 06-126631 BP	2003 IRC	Plan# 2278 Alt	2-story sfr w/attached gara	2006
New	Approved basic 06-126631 BP	2003 IRC	Plan# 2278 Alt	2-story sfr w/attached gara	2006
New	Approved basic 06-126631 BP	2003 IRC	Plan# 2278 Alt	2-story sfr w/attached gara	2006
New	Approved Basic 05-116799BP	2003 IRC		Plan:2597 3 Car	2006
New	Approved Basic 05-127779BP	2003 IRC	2 story SFR w/attached garage	Plan:2278	2006
New	Approved Basic 05-127779BP	2003 IRC	2 story SFR w/attached garage	Plan:2278	2006
New	Approved Basic 05-127779BP	2003 IRC	2 story SFR w/attached garage	Plan:2278	2006
New	Approved basic 06-126631 BP	2003 IRC	Plan# 2278 Alt	2-story sfr w/attached gara	2006
New	Approved Basic 05-127779BP	2003 IRC	2 story SFR w/attached garage	Plan:2278	2006
New	Approved basic 06-126631 BP	2003 IRC	Plan# 2278 Alt	2-story sfr w/attached gara	2006
New	Approved Basic 04-118845BP	2 story SFR w/attached garage	2003 IRC	Plan:2294	2006
New	Approved Basic 04-119639BP		Plan: Eagle-1	Rambler-style SFR with attach	2006
New	Approved Basic 04-119639BP		Plan: Eagle-1	Rambler-style SFR with attach	2006
New	Approved Basic 04-113768BP	2 story SFR w/attached garage	2003 IRC	Plan:3040	2006
New	Approved Basic 05-116166BP	2003 IRC		Plan: Tyhaka	2006
New	Approved Basic 04-119639BP		Plan: Eagle-1	Rambler-style SFR with attach	2006
New	Approved Basic 05-101953BP	2003 IRC	2 story SFR w/attached garage	Plan:Rainier	2006
New	Approved Basic 05-116166BP	2003 IRC		Plan: Tyhaka	2006
New	Approved Basic 04-113768BP	2 story SFR w/attached garage	2003 IRC	Plan:3040	2006
New	Approved Basic 04-119639BP		Plan: Eagle-1	Rambler-style SFR with attach	2006
New	Approved Basic 05-116166BP	2003 IRC		Plan: Tyhaka	2006
New	Approved Basic 04-113768BP	2 story SFR w/attached garage	2003 IRC	Plan:3040	2006
New	Approved Basic 06-101406BP	Two-story SFR w/attached garage	2003 IRC	Plan: Eagle 3	2006
New	Approved Basic 04-119639BP		Plan: Eagle-1	Rambler-style SFR with attach	2006
New	Approved Basic 05-116166BP	2003 IRC		Plan: Tyhaka	2006
New	Approved Basic 04-119639BP		Plan: Eagle-1	Rambler-style SFR with attach	2006
New	Approved Basic 04-116621BP	2 Story SFR w/attached garage	2003 IRC	Plan:1909	2006
New	Two-story SFR with attached garage - 2003 IRC				2006
New	Approved Basic 05-128525 BP	2003 IRC	2 story SFR w/attached garage	Plan:245	2006
New	Approved Basic 05-116799BP	2003 IRC		Plan:2597 3 Car	2006
New	Approved Basic 05-127779BP	2003 IRC	2 story SFR w/attached garage	Plan:2278	2006
New	Approved Basic 06-100083BP	2003 IRC	2 story SFR w/attached garage	Plan:21.	2006
New	Approved Basic 05-127779BP	2003 IRC	2 story SFR w/attached garage	Plan:2278	2006
New	Approved Basic 04-116621BP	2 Story SFR w/attached garage	2003 IRC	Plan:1909	2006
New	Approved Basic 05-128525 BP	2003 IRC	2 story SFR w/attached garage	Plan:245	2006

Accessory Dwelling Units

Index # - File Name: 1.0022 - Single Family Dwellings Data\_Snohomish County.pdf

New	Approved	Basic 05-128525 BP	2003 IRC	2 story SFR w/attached garage	Plan:245	2006	
New	Approved	Basic 04-111161BP	2003 IRC	Plan: 1932 Two-story SFR w/attached ga		2006	
New	Approved	Basic 05-128525 BP	2003 IRC	2 story SFR w/attached garage	Plan:245	2006	
New	2-Story SFR w/attached garage.						2006
New	EXPIRED WITHOUT COUNTY APPROVAL TO USE OR OCCUPY. SENT TO MICROFICHE 7/31/08 DM						2006
New	Approved	basic 06-126684 BP	2003 IRC	Plan# 3552	2-story sfr w/attached garage	2006	
New	Approved	basic 06-126685 BP	2003 IRC	Plan# 3082	2-story sfr w/attached garage	2006	
New	2-story SFR w/attached garage.						2006
New	Two story SFR with attached Garage						2006
New	Approved	Basic 05-127779BP	2003 IRC	2 story SFR w/attached garage	Plan:2278	2006	
New	Approved	Basic 06-100083BP	2003 IRC	2 story SFR w/attached garage	Plan:21:	2006	
New	Approved	Basic 05-127779BP	2003 IRC	2 story SFR w/attached garage	Plan:2278	2006	
New	Approved	Basic 06-100083BP	2003 IRC	2 story SFR w/attached garage	Plan:21:	2006	
New	Approved	Basic 05-127779BP	2003 IRC	2 story SFR w/attached garage	Plan:2278	2006	
New	Approved	Basic 06-100083BP	2003 IRC	2 story SFR w/attached garage	Plan:21:	2006	
New	Approved	Basic 05-127779BP	2003 IRC	2 story SFR w/attached garage	Plan:2278	2006	
New	Approved	Basic 06-100083BP	2003 IRC	2 story SFR w/attached garage	Plan:21:	2006	
New	Approved	basic 05-124430 BP	2003 IRC	Plan# 3078-C	2-story sfr w/attached gara	2006	
New	Two Story SFR with attached Garage						2006
New	Two-story single family residence with attached garage						2006
New	Approved	Basic 05-125299BP	2003 IRC	2 story SFR w/attached garage	Plan:1906	2006	
New	Two-story sfr with attached garage						2006
New	Two Story SFR with 761 SF Finished Basement and Attached Garage						2006
New	Approved	basic 06-126684 BP	2003 IRC	Plan# 3552	2-story sfr w/attached garage	2006	
New	Approved	basic 06-130645 BP	2003 IRC	Plan# 2402	Rambler style sfr w/attach	2006	
New	Approved	basic 06-132168 BP	2003 IRC	Plan# 2869	Rambler style sfr w/attached g	2006	
New	2 story SFR w/ attached 3 car garage						2006
New	Rambler style SFR w/attached garage.						2006
New	2-Story SFR w/attached garage.						2006
New	Two story SFR with attached Garage						2006
New	Two story SFR with attached Garage						2006
New	Two Story SFR with attached Garage						2006
New	Two story SFR with attached Garage						2006
New	Two story SFR with attached Garage						2006
New	Two story SFR with attached Garage						2006
New	Two-story SFR with attached garage - 2003 IRC Plan: Cambridge A						2006
New	Two story SFR with attached Garage						2006
New	Rambler with attached garage ON 10/30/07 THIS PERMIT WAS TRANSFERRED FROM JAMES BRI						2006
New	*Issued under tax roll # 270528-002-019-00* Pending Basic 06-124907BP 2003 IRC 2 sto						2006
New	*Issued under tax roll # 270528-002-019-00* Approved Basic 05-118204BP 2003 IRC						2006
New	2-story sfr w/attached garage						2006
New	Approved	basic 05-128658 BP	2003 IRC	Plan# 3180	2-story sfr w/attached garaç	2006	
New	2 story home w/ attached garage						2006
New	*Issued under tax roll 003730-031-001-08* Two Story SFR with Attached Garage						2006
New	*Issued under tax roll 003730-031-001-08* Two Story SFR with Attached Garage						2006
New	*Issued under tax roll 003730-031-001-08* Two Story SFR with Attached Garage						2006
New	Approved	Basic 05-126594BP	2003 IRC	2 story SFR w/attached garage	Plan:1775	2006	

Accessory Dwelling Units

Index # - File Name: 1.0022 - Single Family Dwellings Data\_Snohomish County.pdf

New	Approved Basic 05-125782BP	2003 IRC	Two story SFR with attached Garage	Plan:2946	2006	
New	Approved Basic 05-125299BP	2003 IRC	2 story SFR w/attached garage	Plan:1906	2006	
New	Approved Basic 05-125785BP	2003 IRC	Two story SFR with attached Garage	Plan:1935	2006	
New	Approved Basic 05-125299BP	2003 IRC	2 story SFR w/attached garage	Plan:1906	2006	
New	Approved Basic 05-126594BP	2003 IRC	2 story SFR w/attached garage	Plan:1775	2006	
New	Approved Basic 05-125785BP	2003 IRC	Two story SFR with attached Garage	Plan:1935	2006	
New	Approved Basic 05-125299BP	2003 IRC	2 story SFR w/attached garage	Plan:1906	2006	
New	Approved Basic 05-125785BP	2003 IRC	Two story SFR with attached Garage	Plan:1935	2006	
New	Approved basic 05-128658 BP	2003 IRC	Plan# 3180	2-story sfr w/attached garage	2006	
New	2-story SFR w/garage				2006	
New	2-story sfr w/attached garage				2006	
New	Two-story SFR with finished basement - 2003 IRC				2006	
New	Two-story SFR w/finished basement				2006	
New	Two story SFR with attached Garage				2006	
New	2-story sfr w/attached garage				2006	
New	Two-story SFR	2003 IRC	Builder s Plan:3162		2006	
New	Two-story sfr with attached garage				2006	
New	Approved basic 05-128658 BP	2003 IRC	Plan# 3180	2-story sfr w/attached garage	2006	
New	Approved basic 05-127403 BP	2003 IRC	Plan# 50060 A-2	2-story sfr w/attached garage	2006	
New	Two-story sfr with attached garage				2006	
New	Approved basic 05-128658 BP	2003 IRC	Plan# 3180	2-story sfr w/attached garage	2006	
New	Two-story SFR with attached garage - 2003 IRC				2006	
New	Approved basic 05-126970 BP	2003 IRC	Plan# 40050-A2	2-story sfr w/attached garage	2006	
New	Approved Basic 05-100164BP	2003 IRC	Plan: 40040-A2S Two-story SFR w		2006	
New	Approved basic 05-126970 BP	2003 IRC	Plan# 40050-A2	2-story sfr w/attached	2006	
New	Approved basic 05-126970 BP	2003 IRC	Plan# 40050-A2	2-story sfr w/attached	2006	
New	Approved Basic 04-115137BP	2003 IRC	2 story SFR w/attached garage	Plan:50070-A3T	2006	
New	Approved Basic 05-129345BP	2003 IRC	Plan: 2054	Two-story SFR with attached	2006	
New	2-story SFR w/garage				2006	
New	Approved basic 05-124781 BP	2003 IRC	Plan# 35011-A2	2-story sfr w/attached garage	2006	
New	Approved basic 05-127403 BP	2003 IRC	Plan# 50060 A-2	2-story sfr w/attached garage	2006	
New	Approved basic 05-124781 BP	2003 IRC	Plan# 35011-A2	2-story sfr w/attached garage	2006	
New	Approved basic 05-127778 BP	2003 IRC	Plan# 40060-AZ	2-story sfr w/attached garage	2006	
New	Approved basic 05-127778 BP	2003 IRC	Plan# 40060-AZ	2-story sfr w/attached garage	2006	
New	Approved Basic 04-114800BP	Plan: 40020-A2 Two-story SFR - 2003 IRC			2006	
New	Approved basic 05-126970 BP	2003 IRC	Plan# 40050-A2	2-story sfr w/attached	2006	
New	Approved Basic 04-114800BP	Plan: 40020-A2 Two-story SFR - 2003 IRC			2006	
New	Approved basic 04-115849 BP					2006
New	Approved Basic 04-120496BP	split plan w/attached garage	2003 IRC	Plan:2000S	2006	
New	Approved basic 05-126438 BP	2003 IRC	Plan# Unit type B	2-story sfr w/out garage	2006	
New	Approved basic 05-126437 BP	2003 IRC	Plan# Unit type A	2-story sfr w/out garage	2006	
New	Approved basic 05-126441 BP	2003 IRC	Plan# Unit type D	2-story sfr w/out garage	2006	
New	Approved basic 05-126441 BP	2003 IRC	Plan# Unit type D	2-story sfr w/out garage	2006	
New	Approved basic 05-126438 BP	2003 IRC	Plan# Unit type B	2-story sfr w/out garage	2006	
New	Approved basic 05-126439 BP	2003 IRC	Plan# Unit type C	2-story sfr w/out garage	2006	
New	Approved basic 05-126438 BP	2003 IRC	Plan# Unit type B	2-story sfr w/out garage	2006	
New	Approved basic 05-126438 BP	2003 IRC	Plan# Unit type B	2-story sfr w/out garage	2006	

Accessory Dwelling Units

Index # - File Name: 1.0022 - Single Family Dwellings Data\_Snohomish County.pdf

New	Approved basic	05-126441 BP	2003 IRC	Plan# Unit type D	2-story sfr w/out ga	2006
New	Approved basic	05-126441 BP	2003 IRC	Plan# Unit type D	2-story sfr w/out ga	2006
New	Approved basic	05-126438 BP	2003 IRC	Plan# Unit type B	2-story sfr w/out gar	2006
New	Approved basic	05-126438 BP	2003 IRC	Plan# Unit type B	2-story sfr w/out gar	2006
New	Approved basic	05-126438 BP	2003 IRC	Plan# Unit type B	2-story sfr w/out gar	2006
New	Approved basic	05-126438 BP	2003 IRC	Plan# Unit type B	2-story sfr w/out gar	2006
New	Approved basic	05-126437 BP	2003 IRC	Plan# Unit type A	2-story sfr w/out gara	2006
New	Approved basic	05-126439 BP	2003 IRC	Plan# Unit type C	2-story sfr w/out garage	2006
New	Approved basic	05-126438 BP	2003 IRC	Plan# Unit type B	2-story sfr w/out gar	2006
New	Approved basic	05-126438 BP	2003 IRC	Plan# Unit type B	2-story sfr w/out gar	2006
New	Approved basic	05-126439 BP	2003 IRC	Plan# Unit type C	2-story sfr w/out garage	2006
New	Approved basic	05-126437 BP	2003 IRC	Plan# Unit type A	2-story sfr w/out gara	2006
New	Approved basic	05-126438 BP	2003 IRC	Plan# Unit type B	2-story sfr w/out gar	2006
New	Approved basic	05-126438 BP	2003 IRC	Plan# Unit type B	2-story sfr w/out gar	2006
New	Approved basic	05-126438 BP	2003 IRC	Plan# Unit type B	2-story sfr w/out gar	2006
New	Approved basic	05-126437 BP	2003 IRC	Plan# Unit type A	2-story sfr w/out gara	2006
New	Approved basic	05-126441 BP	2003 IRC	Plan# Unit type D	2-story sfr w/out ga	2006
New	Approved basic	05-126439 BP	2003 IRC	Plan# Unit type C	2-story sfr w/out garage	2006
New	Approved basic	05-126438 BP	2003 IRC	Plan# Unit type B	2-story sfr w/out ga	2006
New	Approved Basic	05-124140 BP	2003 IRC	Plan: 3188	One-story SFR w/finished baseme	2006
New	Two-story SFR with attached garage - 2003 IRC					2006
New	Approved Basic	05-129347BP	2003 IRC	Plan: 2001	Two-story SFR w/attached garage	2006
New	Approved Basic	05-129344BP	2003 IRC	Plan 2104	Two-story SFR w/attached garage	2006
New	Approved Basic	05-129346BP	2003 IRC	Plan: 2136	Two-story SFR w/attached garage	2006
New	Approved Basic	05-129344BP	2003 IRC	Plan 2104	Two-story SFR w/attached garage	2006
New	Approved Basic	05-129346BP	2003 IRC	Plan: 2136	Two-story SFR w/attached garage	2006
New	Approved Basic	05-129347BP	2003 IRC	Plan: 2001	Two-story SFR w/attached garage	2006
New	Approved Basic	05-129347BP	2003 IRC	Plan: 2001	Two-story SFR w/attached garage	2006
New	Approved Basic	05-129346BP	2003 IRC	Plan: 2136	Two-story SFR w/attached garage	2006
New	Approved Basic	05-129344BP	2003 IRC	Plan 2104	Two-story SFR w/attached garage	2006
New	Approved Basic	05-129346BP	2003 IRC	Plan: 2136	Two-story SFR w/attached garage	2006
New	Approved Basic	05-129345BP	2003 IRC	Plan: 2054	Two-story SFR w/attached garage	2006
New	Approved Basic	05-129347BP	2003 IRC	Plan: 2001	Two-story SFR w/attached garage	2006
New	Approved Basic	05-129346BP	2003 IRC	Plan: 2136	Two-story SFR w/attached garage	2006
New	Approved Basic	05-129345BP	2003 IRC	Plan: 2054	Two-story SFR w/attached garage	2006
New	Approved Basic	05-129344BP	2003 IRC	Plan 2104	Two-story SFR w/attached garage	2006
New	Approved Basic	05-129346BP	2003 IRC	Plan: 2136	Two-story SFR w/attached garage	2006
New	Approved Basic	05-129344BP	2003 IRC	Plan 2104	Two-story SFR w/attached garage	2006
New	Approved Basic	05-129346BP	2003 IRC	Plan: 2136	Two-story SFR w/attached garage	2006
New	Approved Basic	05-129345BP	2003 IRC	Plan: 2054	Two-story SFR w/attached garage	2006
New	Approved basic #05-	120993 BP	2003 IRC	SFR w/attached garage	Plan #244	2006
New	Approved basic #05-	120993 BP	2003 IRC	SFR w/attached garage	Plan #244	2006
New	Two-story sfr with attached garage					2006
New	Approved Basic	04-117064BP	2003 IRC	Plan:Appalachian I	Two-story SFR w/attached garage	2006
New	Approved basic	05-126441 BP	2003 IRC	Plan# Unit type D	2-story sfr w/out ga	2006
New	Approved basic	05-126439 BP	2003 IRC	Plan# Unit type C	2-story sfr w/out garage	2006
New	Approved basic	05-126441 BP	2003 IRC	Plan# Unit type D	2-story sfr w/out ga	2006



Accessory Dwelling Units

Index # - File Name: 1.0022 - Single Family Dwellings Data\_Snohomish County.pdf

New	Approved basic	05-126441 BP	2003 IRC	Plan#	Unit type D	2-story sfr w/out ga	2006
New	Approved basic	05-126437 BP	2003 IRC	Plan#	Unit type A	2-story sfr w/out gara	2006
New	Approved basic	05-126441 BP	2003 IRC	Plan#	Unit type D	2-story sfr w/out ga	2006
New	Approved basic	05-126441 BP	2003 IRC	Plan#	Unit type D	2-story sfr w/out ga	2006
New	Approved basic	05-126438 BP	2003 IRC	Plan#	Unit type B	2-story sfr w/out gar	2006
New	Approved basic	05-126441 BP	2003 IRC	Plan#	Unit type D	2-story sfr w/out ga	2006
New	Approved basic	05-126441 BP	2003 IRC	Plan#	Unit type D	2-story sfr w/out ga	2006
New	Approved basic	05-126438 BP	2003 IRC	Plan#	Unit type B	2-story sfr w/out gar	2006
New	Approved basic	05-126441 BP	2003 IRC	Plan#	Unit type D	2-story sfr w/out ga	2006
New	Approved basic	05-126437 BP	2003 IRC	Plan#	Unit type A	2-story sfr w/out gara	2006
New	Approved basic	05-126437 BP	2003 IRC	Plan#	Unit type A	2-story sfr w/out gara	2006
New	Approved basic	05-126441 BP	2003 IRC	Plan#	Unit type D	2-story sfr w/out ga	2006
New	Approved basic	05-126438 BP	2003 IRC	Plan#	Unit type B	2-story sfr w/out gar	2006
New	Approved basic	05-126441 BP	2003 IRC	Plan#	Unit type D	2-story sfr w/out ga	2006
New	Approved basic	05-126437 BP	2003 IRC	Plan#	Unit type A	2-story sfr w/out gara	2006
New	Approved basic	05-126439 BP	2003 IRC	Plan#	Unit type C	2-story sfr w/out garage	2006
New	Approved basic	05-126438 BP	2003 IRC	Plan#	Unit type B	2-story sfr w/out gar	2006
New	Two-story SFR		2003 IRC				2006
New	Two-story SFR w/finished basement						2006
New	Rambler with daylight basement & attached garage						2006
New	REINSPECTION FEE OF \$60 NEEDS TO BE PAID PRIOR TO NEXT SITE VISIT, please notify Donna N						2006
New	One story SFR						2006
New	1340 square foot split level SFR						2006
New	Approved Basic	05-121797BP	2003 IRC		Rambler style SFR w/attached garage	Plan:	2006
New	Approved basic	06-129078 BP	2003 IRC	Plan# 2838	2 story with attached 3 car gara		2006
New	82 x 54 SFR with attached garage						2006
New	Approved Basic	05-126102BP	2003 IRC		2 story SFR w/attached garage	Plan:2147	2006
New	Approved Basic	05-121624BP	2003 IRC		2 story SFR w/ attached garage	Plan:1733	2006
New	Approved Basic	06-102296 BP		2003 IRC		Builders Plan: 2717 T	2006
New	Approved Basic	05-126094BP	2003 IRC		2 story SFR w/attached garage	Plan:2104H	2006
New	Approved Basic	05-126092BP	2003 IRC		2 story SFR w/attached garage	Plan:2104	2006
New	Unfinished basement						2006
New	Two-story SFR						2006
New	Approved Basic	05-123957BP	2003 IRC	Plan:1852	SFR w/finished basement & attache		2006
New	Approved Basic	05-126094BP	2003 IRC		2 story SFR w/attached garage	Plan:2104H	2006
New	Approved Basic	06-102296 BP		2003 IRC		Builders Plan: 2717 T	2006
New	Approved Basic	05-123957BP	2003 IRC	Plan:1852	SFR w/finished basement & attache		2006
New	Approved Basic	06-100780 BP		2003 IRC		Builders Plan: 2023 T	2006
New	Approved Basic	06-102296 BP		2003 IRC		Builders Plan: 2717 T	2006
New	Approved Basic	06-100780 BP		2003 IRC		Builders Plan: 2023 T	2006
New	Approved Basic	06-102296 BP		2003 IRC		Builders Plan: 2717 T	2006
New	Approved Basic	06 102296 BP		2003 IRC		Builders Plan: 2717 Two-story S	2006
New	Approved basic	05-101403 BP	2003 IRC	Plan# 3352-3	2 story sfr w/attached garage		2006
New	Approved Basic	06-100780BP	Two-story SFR with attached garage -2003 IRC	Plan:	2023 Pin P		2006
New	Approved Basic	06-100780BP	Two-story SFR with attached garage -2003 IRC	Plan:	2023 Pin P		2006
New	Approved Basic	06-100780BP	Two-story SFR with attached garage -2003 IRC	Plan:	2023 Pin P		2006
New	Approved Basic	06-100780BP	Two-story SFR with attached garage -2003 IRC	Plan:	2023 Pin P		2006

Accessory Dwelling Units

Index # - File Name: 1.0022 - Single Family Dwellings Data\_Snohomish County.pdf

New	Approved Basic 05-126102BP	2003 IRC	2 story SFR w/attached garage	Plan:2147	2006
New	Approved basic 05-101403 BP	2003 IRC	Plan# 3352-3	2 story sfr w/attached garage	2006
New	Approved Basic 06-129955 BP	2003 IRC	Plan: 3331	Two story SFR with attached Garag	2006
New	Approved Basic # 06-129951 BP	2003 IRC	Plan: 3427	Two	2006
New	*issued under tax roll # 003737-008-004-01* 2-story sfr w/attached garage				2006
New	Approved Basic 05-129349BP	2003 IRC	2 story SFR w/attached garage	Plan:3358	2006
New	Approved Basic 05-116878BP	2003 IRC	Plan: 3370-3		2006
New	Approved Basic # 06-129951 BP	2003 IRC	Plan: 3427	2-story sfr w/attached Gara	2006
New	Two story SFR with attached Garage				2006
New	Approved basic 05-101403 BP	2003 IRC	Plan# 3352-3	2 story sfr w/attached garage	2006
New	Approved Basic 06-129955 BP	2003 IRC	Plan: 3331	Two story SFR with attached Garag	2006
New	Approved Basic 06-126829 BP	2003 IRC	2 story w/ attached 3 car garage	Bldr Plan: 3	2006
New	Approved Basic #05-124117 BP	2003 IRC	2 story SFR w/attached garage	Plan:3101	2006
New	Approved basic 05-101403 BP	2003 IRC	Plan# 3352-3	2 story sfr w/attached garage	2006
New	Approved Basic #05-124117 BP	2003 IRC	2 story SFR w/attached garage	Plan:3101	2006
New	Approved Basic # 06-126052 BP	2003 IRC	Plan:3082A	Two story SFR with attached Ga	2006
New	Approved basic 05-101398 BP	2003 IRC	Plan # 3259-3	2 story sfr w/attached garag	2006
New	Approved basic 05-101403 BP	2003 IRC	Plan# 3352-3	2 story sfr w/attached garage	2006
New	Approved Basic 06-1266829 BP	2003 IRC	2 story w/ attached 3 car garage	Bldr Plan:	2006
New	Approved basic 05-101403 BP	2003 IRC	Plan# 3352-3	2 story sfr w/attached garage	2006
New	55 ft x 63 ft two story SFR with attached garage				2006
New	SENT PERMIT FOLDER TO RECORDS ROOM 10/23/08 DM Approved basic 06-131791 BP				2006
New	2-story SFR w/attached garage.				2006
New	Approved Basic 05-122829BP	2003 IRC	2 story SFR w/attached garage	Plan:1809	2006
New	Approved basic 05-124323 BP	2003 IRC	Plan#30020-A2	2-story sfr w/attache	2006
New	Approved basic 05-123556 BP	2003 IRC	Plan# 30030-A2	2-story sfr w/attached g	2006
New	Approved basic 05-127404 BP	2003 IRC	Plan# 30040 A-2	2-story sfr w/attache	2006
New	Two story SFR with Attached Garage BFE = 45				2006
New	2-story sfr w/attached garage				2006
New	Approved basic 05-126370 BP	2003 IRC	Plan # 226-1007	2-story sfr w/attached gara	2006
New	Approved basic 05-124781 BP	2003 IRC	Plan# 35011-A2	2-story sfr w/attached gara	2006
New	Approved basic 05-123555 BP	2003 IRC	Plan# 30010-A2	2-story sfr w/attached gar	2006
New	2-story sfr w/attached garage				2006
New	Approved Basic 05- 123059BP	2003 IRC	Plan: 2160	Two-story SFR w	2006
New	Approved Basic 05- 123059BP	2003 IRC	Plan: 2160	Two-story SFR w	2006
New	Approved Basic 05- 123059BP	2003 IRC	Plan: 2160	Two-story SFR w	2006
New	Approved Basic 05- 123059BP	2003 IRC	Plan: 2160	Two-story SFR w	2006
New	Approved Basic 05- 123059BP	2003 IRC	Plan: 2160	Two-story SFR w	2006
New	Approved Basic 05- 123059BP	2003 IRC	Plan: 2160	Two-story SFR w	2006
New	Approved Basic 05- 123059BP	2003 IRC	Plan: 2160	Two-story SFR w	2006
New	Approved Basic 05-122829BP	2003 IRC	2 story SFR w/attached garage	Plan:1809	2006
New	Approved Basic 05-122829BP	2003 IRC	2 story SFR w/attached garage	Plan:1809	2006
New	Approved Basic 05-122829BP	2003 IRC	2 story SFR w/attached garage	Plan:1809	2006
New	Approved Basic 05-122829BP	2003 IRC	2 story SFR w/attached garage	Plan:1809	2006
New	Approved Basic 05- 123059BP	2003 IRC	Plan: 2160	Two-story SFR w	2006
New	Approved Basic 05-122829BP	2003 IRC	2 story SFR w/attached garage	Plan:1809	2006
New	Approved basic 05-126370 BP	2003 IRC	Plan # 226-1007	2-story sfr w/attached gara	2006

Accessory Dwelling Units

Index # - File Name: 1.0022 - Single Family Dwellings Data\_Snohomish County.pdf

New	Approved basic 05-126368 BP	2003 IRC	Plan # 226-1002	2-story sfr w/attached gara	2006
New	Approved basic 05-126373 BP	2003 IRC	Plan # 226-1001	2-story sfr w/attached gara	2006
New	Approved basic 05-126373 BP	2003 IRC	Plan # 226-1001	2-story sfr w/attached gara	2006
New	Approved basic 05-126370 BP	2003 IRC	Plan # 226-1007	2-story sfr w/attached gara	2006
New	Approved basic 05-126368 BP	2003 IRC	Plan # 226-1002	2-story sfr w/attached gara	2006
New	Approved basic 05-126370 BP	2003 IRC	Plan # 226-1007	2-story sfr w/attached gara	2006
New	Approved basic 05-126368 BP	2003 IRC	Plan # 226-1002	2-story sfr w/attached gara	2006
New	2-story sfr w/attached garage				2006
New	2741 sq ft Rambler with attached Garage				2006
New	Two-story SFR				2006
New	Approved basic 05-126370 BP	2003 IRC	Plan # 226-1007	2-story sfr w/attached gara	2006
New	Approved basic 05-126370 BP	2003 IRC	Plan # 226-1007	2-story sfr w/attached gara	2006
New	Approved basic 05-125057 BP	2003 IRC	Plan # 2433 A & B	2-story sfr w/attached ga	2006
New	Approved basic 05-125057 BP	2003 IRC	Plan # 2433 A & B	2-story sfr w/attached ga	2006
New	Approved basic 05-124883 BP	2003 IRC	Plan# 2423-A & B	2-story sfr w/attache	2006
New	Approved basic 05-125057 BP	2003 IRC	Plan # 2433 A & B	2-story sfr w/attached ga	2006
New	Approved basic 05-124883 BP	2003 IRC	Plan# 2423-A & B	2-story sfr w/attache	2006
New	Approved basic 05-125057 BP	2003 IRC	Plan # 2433 A & B	2-story sfr w/attached ga	2006
New	Approved Basic 04- 119008BP		Plan: 2488	Two-story SFR with attached 2-	2006
New	Approved basic 05-125057 BP	2003 IRC	Plan # 2433 A & B	2-story sfr w/attached ga	2006
New	Rambler w/2nd floor bonus room and attached garage				2006
New	2-story sfr w/attached garage				2006
New	Approved Basic 06-101760BP	2003 IRC	2 story SFR w/attached garage	Plan:35	2006
New	2 story SFR w/attached garage	2003 IRC	Plan:3532- The Cedar River		2006
New	One story SFR	2003 IRC			2006
New	Approved Basic 04-116301BP	2003 IRC	2 story SFR w/attached garage	Plan:2590	2006
New	Approved Basic 05-123535BP	2003 IRC	2 story SFR w/attached garage	Plan:50	2006
New	Approved basic 05-121183BP	2003 IRC	Plan# 3006B-B	2-story sfr w/attached gar	2006
New	Approved Basic 05-120109BP	2003 IRC	2 story SFR w/attached garage	Plan:3025A	2006
New	Approved Basic 05-120107BP	2003 IRC	2 story SFR w/attached garage	Plan:3027-B	2006
New	Approved Basic 05-119824BP	2003 IRC	2 story SFR w/attached garage	Plan:3026A	2006
New	Approved basic 05-120613BP	2003 IRC	Plan # 4916-A	2-story sfr w/attached garage	2006
New	Approved Basic 05-120106BP	2003 IRC	2 story SFR w/attached garage	Plan:30	2006
New	Approved Basic 05-122718BP	2003 IRC	2 story SFR w/attached garage	Plan:5025L-A	2006
New	Approved Basic 05-119824BP	2003 IRC	2 story SFR w/attached garage	Plan:3026A	2006
New	Approved Basic 05-120110BP	2003 IRC	2 story SFR w/attached garage	Plan:302	2006
New	Approved Basic 05-124413BP	2003 IRC	2 story SFR w/attached garage	Plan:5025L	2006
New	Approved basic 05-121187 BP	2003 IRC	Plan#4010D-B	2-story sfr w/attached garage	2006
New	Approved basic 05-120611 BP	2003 IRC	Plan # 4916 - B	2 story sfr w/attached gara	2006
New	Two story SFR with attached Garage				2006
New	Approved Basic 06-102416BP	2003 IRC	Rambler w/attached 3 car garage	Plan:26	2006
New	Rambler with daylight basement and attached garage				2006
New	Two story SFR with attached Garage				2006
New	2585 sq ft Rambler with daylite Basement & attached Garage				2006
New	Approved Basic 06-101760BP	2003 IRC	2 story SFR w/attached garage	Plan:35	2006
New	2-story sfr w/attached garage				2006
New	Rambler style SFR w/attached garage.				2006

Accessory Dwelling Units

Index # - File Name: 1.0022 - Single Family Dwellings Data\_Snohomish County.pdf

New	Rambler w/daylight basement attached garage					2006
New	2-story sfr w/attached garage					2006
New	One-story SFR with semi-finished basement	2003 IRC				2006
New	SFR w/finished basement & attached garage	2003 IRC				2006
New	2 story SFR w/finished basement & attached garage	2003 IRC				2006
New	Rambler w/ attached 3 car garage					2006
New	Two story SFR - 2003 IRC			Builders Plan: 3105		2006
New	Two story SFR with attached Garage					2006
New	Approved Basic 06-126671BP	Rambler-style SFR	2003 IRC	Plan: 2759		2006
New	Approved Basic 06-126671BP	Rambler-style SFR	2003 IRC	Plan: 2759		2006
New	Rambler w/ attached 3 car garage					2006
New	1 story SFR w/attached garage	2003IRC				2006
New	SENT PERMIT FOLDER TO RECORDS ROOM 10/27/08 DM	76 ft x 80 ft SFR with attached garage				2006
New	SFR with Finished Basement and Attached Garage					2006
New	Approved Basic 05 129105 BP			Builder s Plan: 2650 2 S		2006
New	Approved basic 05-128494 BP	2003 IRC	Plan# Belair	2-story sfr w/attached gar		2006
New	Approved basic 05-128758 BP	2003 IRC	Plan# Elanor	2-story sfr w/attached garag		2006
New	Approved basic 05-128493 BP	2003 IRC	Plan# Jackson	2-story sfr w/attached		2006
New	Approved basic 05-128758 BP	2003 IRC	Plan# Elanor	2-story sfr w/attached garag		2006
New	THIS BASIC CAN ONLY BE USED IN ZONES ALLOWING 30 HEIGHT OR MORE	Approved basic 05-				2006
New	Approved Basic 05-122760BP	2003 IRC	2 story SFR, unfin. bsmnt w/ 2 car garage	Plan: Blak		2006
New	Approved basic 05-128493 BP	2003 IRC	Plan# Jackson	2-story sfr w/attached		2006
New	THIS BASIC CAN ONLY BE USED IN ZONES ALLOWING 30 HEIGHT OR MORE	Approved basic 05-				2006
New	Approved Basic 05-101253BP		2003 IRC	Plan:Madison		2006
New	approved 06-100678 BP	2003 IRC	Plan# Gregory	2-story sfr w/attached garage		2006
New	Approved basic 06-100658 BP	2003 IRC	Plan# Langston	2-story sfr w/attached garage		2006
New	2-story sfr w/attached garage					2006
New	Approved basic 05-128756 BP	2003 IRC	Plan# Austin	2-story sfr w/semi fin bsmt & atchd ga		2006
New	Approved basic 06-101344 BP	2003 IRC	Plan# Easton	2-story sfr w/attached		2006
New	Approved basic 05-128756 BP	2003 IRC	Plan# Austin	2-story sfr w/semi fin bsmt & atchd ga		2006
New	Approved basic 06-101344 BP	2003 IRC	Plan# Easton	2-story sfr w/attached		2006
New	Approved basic 05-128756 BP	2003 IRC	Plan# Austin	2-story sfr w/semi fin bsmt & atchd ga		2006
New	Approved basic 06-101344 BP	2003 IRC	Plan# Easton	2-story sfr w/attached		2006
New	Approved basic 05-128756 BP	2003 IRC	Plan# Austin	2-story sfr w/semi fin bsmt & atchd ga		2006
New	Approved Basic 05-122760BP	2003 IRC	2 story SFR, unfin. bsmnt w/ 2 car garage	Plan: Blak		2006
New	Approved basic 05-128493 BP	2003 IRC	Plan# Jackson	2-story sfr w/attached		2006
New	THIS BASIC CAN ONLY BE USED IN ZONES ALLOWING 30 HEIGHT OR MORE	Approved basic 05-				2006
New	Approved basic 05-128493 BP	2003 IRC	Plan# Jackson	2-story sfr w/attached		2006
New	Approved basic 05-128758 BP	2003 IRC	Plan# Elanor	2-story sfr w/attached garag		2006
New	Approved basic 05-128493 BP	2003 IRC	Plan# Jackson	2-story sfr w/attached		2006
New	2 story w/ attchd. 3 car garage					2006
New	Approved basic 05-125016 BP	2003 IRC	Plan# 2800	2-story sfr w/attached ga		2006
New	Approved Basic 05-123237 BP	2003 IRC	Plan# 2211	2-story sfr w/attached garage		2006
New	2-story sfr w/attached garage					2006
New	2-story sfr w/attached garage					2006
New	2-story sfr w/attached garage					2006
New	Approved Basic 04-120237BP		Plan: 3510	Two-story SFR with attached 3-car		2006

Accessory Dwelling Units

Index # - File Name: 1.0022 - Single Family Dwellings Data\_Snohomish County.pdf

New	Two-story SFR with attached garage - 2003 IRC				2006
New	Approved basic 05-120412 BP	2003 IRC	Plan# 2600	2-story sfr w/attached garage	2006
New	Approved basic 05-120412 BP	2003 IRC	Plan# 2600	2-story sfr w/attached garage	2006
New	2-story sfr w/attached garage				2006
New	Approved Basic 05-123237 BP	2003 IRC	Plan# 2211	2-story sfr w/attached garage	2006
New	Approved basic 05-125156 BP	2003 IRC	Plan# 2700	2-story sfr w/attached garage	2006
New	Approved basic 05-120412 BP	2003 IRC	Plan# 2600	2-story sfr w/attached garage	2006
New	2 story SFR w/attached garage	2003 IRC	Plan:2559/Amesbury		2006
New	2-story sfr w/attached garage				2006
New	Approved basic 05-127990 BP	2003 IRC	Plan# 2-1825	2-story sfr w/attached garage	2006
New	Approved basic 05-120412 BP	2003 IRC	Plan# 2600	2-story sfr w/attached garage	2006
New	Approved basic 05-120411 BP	2003 IRC	Plan# 2300	2-story sfr w/attached garage	2006
New	Approved basic 05-125016 BP	2003 IRC	Plan# 2800	2-story sfr w/attached garage	2006
New	Approved basic 05-120412 BP	2003 IRC	Plan# 2600	2-story sfr w/attached garage	2006
New	Approved Basic 05-123237 BP	2003 IRC	Plan# 2211	2-story sfr w/attached garage	2006
New	Approved basic 05-125016 BP	2003 IRC	Plan# 2800	2-story sfr w/attached garage	2006
New	Approved basic 05-125156 BP	2003 IRC	Plan# 2700	2-story sfr w/attached garage	2006
New	Approved basic 05-125016 BP	2003 IRC	Plan# 2800	2-story sfr w/attached garage	2006
New	Approved basic 05-125016 BP	2003 IRC	Plan# 2800	2-story sfr w/attached garage	2006
New	Approved basic 05-125156 BP	2003 IRC	Plan# 2700	2-story sfr w/attached garage	2006
New	Approved basic 05-125156 BP	2003 IRC	Plan# 2700	2-story sfr w/attached garage	2006
New	Approved basic 05-125156 BP	2003 IRC	Plan# 2700	2-story sfr w/attached garage	2006
New	Two story SFR with attached Garage				2006
New	Approved basic 05-121526 BP	2003 IRC	Plan#2452	2-story sfr w/attached garage	2006
New	Approved Basic 05-121525 BP	2003 IRC	Plan# 2591	2-story sfr w/attached garage	2006
New	Approved basic 05-121526 BP	2003 IRC	Plan#2452	2-story sfr w/attached garage	2006
New	Approved basic 05-127990 BP	2003 IRC	Plan# 2-1825	2-story sfr w/attached garage	2006
New	Approved Basic 05-116799BP		2003 IRC	Plan:2597 3 Car	2006
New	*Issued under tax roll # 004733-000-016-24*			Two story SFR with finished Basement & attached	2006
New	Approved Basic 06-133789 BP		2003 IRC	Plan: 3237-3 Two s	2006
New	Approved basic 05-127990 BP	2003 IRC	Plan# 2-1825	2-story sfr w/attached garage	2006
New	Approved Basic 05-124386BP	2003 IRC		2 story SFR w/attached garage Plan:2065	2006
New	Approved Basic # 05-123468 BP	2003 IRC	Plan: 3065	2 Story SFR w/attached Garage	2006
New	Two-story SFR	2003 IRC			2006
New	2 story SFR w/attached garage	2003 IRC	Plan:2248		2006
New	One-story SFR				2006
New	Approved Basic 05-124146BP	2003 IRC		2 story SFR w/attached garage Plan: 2541	2006
New	Approved Basic 05-124146BP	2003 IRC		2 story SFR w/attached garage Plan: 2541	2006
New	Approved Basic 04-118845BP	2 story SFR w/attached garage	2003 IRC	Plan:2294	2006
New	Approved Basic 05-124146BP	2003 IRC		2 story SFR w/attached garage Plan: 2541	2006
New	Approved Basic 05-119780BP	2003 IRC		2 story SFR w/attached garage Plan:2463	2006
New	Approved Basic 05-116799BP		2003 IRC	Plan:2597 3 Car	2006
New	Approved Basic 05-116799BP		2003 IRC	Plan:2597 3 Car	2006
New	New Permit #08-107083 STOP WORK ORDER LIFTED 11/13/06 PER TIM ELDER STOP WORK OR				2006
New	Approved Basic 05-118335BP	2003 IRC	Plan:1932 BSM		2006
New	Rambler with finished daylight basement and attached garage with shop/storage area - 2003 IRC				2006
New	Approved Basic 05-100936-BP	2003 IRC		Plan:1703-Bonus	2006



Accessory Dwelling Units

Index # - File Name: 1.0022 - Single Family Dwellings Data\_Snohomish County.pdf

New	Two-story SFR		Builders Plan: Waterford B	2006
New	Two story SFR with attached Garage			2006
New	2-Story SFR w/attached garage.			2006
New	2-Story SFR w/attached garage.			2006
New	Approved Basic 05-116166BP	2003 IRC	Plan: Tyhaka	2006
New	Approved Basic 04-115047BP	1 story SFR w/attached garage	2003 IRC Plan:Eagle 2	2006
New	Approved Basic 04-113768BP	2 story SFR w/attached garage	2003 IRC Plan:3040	2006
New	Approved Basic 04-119639BP		Plan: Eagle-1 Rambler-style SFR with attach	2006
New	Two-story sfr with attached garage			2006
New	Approved basic 05-120159 BP	2003 IRC	Plan# TS JEB 2 story SFR w/attached garg	2006
New	Approved Basic 05-118736BP	2003 IRC	2 story SFR w/attached garage Plan:2999w/	2006
New	Approved Basic 05-118741BP	2003 IRC	2 story SFR w/attached garage Plan:2786\	2006
New	Approved Basic 05-118736BP	2003 IRC	2 story SFR w/attached garage Plan:2999w/	2006
New	Approved Basic 05-118736BP	2003 IRC	2 story SFR w/attached garage Plan:2999w/	2006
New	Approved Basic 06-127811BP	2003IRC	Two-story SFR with attached garage Plan: 2505	2006
New	Approved Basic 05-118741BP	2003 IRC	2 story SFR w/attached garage Plan:2786\	2006
New	2 story SFR w/attached garage	2003 IRC	Plan: 3	2006
New	Approved Basic 06-127815BP	2003IRC	Two-story SFR with attached garage Plan: 2706	2006
New	Approved Basic 05-118736BP	2003 IRC	2 story SFR w/attached garage Plan:2999w/	2006
New	2 story SFR w/attached garage	2003 IRC	Plan:2505	2006
New	2 story SFR w/attached garage	2003 IRC		2006
New	Approved Basic 05-118736BP	2003 IRC	2 story SFR w/attached garage Plan:2999w/	2006
New	Approved Basic 05-118728BP	2003 IRC	2 story SFR w/attached garage Plan:3;	2006
New	Approved Basic 05-118736BP	2003 IRC	2 story SFR w/attached garage Plan:2999w/	2006
New	Approved Basic 05-118736BP	2003 IRC	2 story SFR w/attached garage Plan:2999w/	2006
New	Two-story SFR with attached garage	2003-IRC	Plan: Preston A 3-car	2006
New	Two story SFR with attached Garage			2006
New	Two story SFR with attached Garage			2006
New	Two-story SFR with attached garage	2003 IRC	Plan: Stratford B 3-car	2006
New	Two-story SFR with attached 3-car garage	2003IRC	Rainier B 3-car	2006
New	Two-story SFR with attached 3-car garage	2003IRC	Rainier A 3-car	2006
New	2 story SFR w/attached garage	2003 IRC	Plan:4	2006
New	Approved Basic 05-118736BP	2003 IRC	2 story SFR w/attached garage Plan:2999w/	2006
New	2-story sfr w/attached garage			2006
New	2-story sfr w/attached garage			2006
New	2-story sfr w/attached garage			2006
New	Approved Basic 05-118736BP	2003 IRC	2 story SFR w/attached garage Plan:2999w/	2006
New	Approved Basic 05-118741BP	2003 IRC	2 story SFR w/attached garage Plan:2786\	2006
New	Approved Basic 05-118736BP	2003 IRC	2 story SFR w/attached garage Plan:2999w/	2006
New	Approved Basic 06-127815BP	2003IRC	Two-story SFR with attached garage Plan: 2706	2006
New	Approved Basic 05-118728BP	2003 IRC	2 story SFR w/attached garage Plan:3;	2006
New	Approved Basic 05-118734BP	2003 IRC	2 story SFR w/attached garage Plan:2999w/	2006
New	Approved Basic 05-118736BP	2003 IRC	2 story SFR w/attached garage Plan:2999w/	2006
New	Approved Basic 05-118741BP	2003 IRC	2 story SFR w/attached garage Plan:2786\	2006
New	Approved Basic 06-127811BP	2003IRC	Two-story SFR with attached garage Plan: 2505	2006
New	Approved Basic 05-118728BP	2003 IRC	2 story SFR w/attached garage Plan:3;	2006
New	Approved Basic 05-118736BP	2003 IRC	2 story SFR w/attached garage Plan:2999w/	2006

Accessory Dwelling Units

Index # - File Name: 1.0022 - Single Family Dwellings Data\_Snohomish County.pdf

New	Approved Basic 05-118741BP	2003 IRC	2 story SFR w/attached garage	Plan:2786\	2006
New	Approved Basic 05-118736BP	2003 IRC	2 story SFR w/attached garage	Plan:2999w/	2006
New	Approved Basic 06-127811BP	2003IRC	Two-story SFR with attached garage	Plan: 2505	2006
New	Approved Basic 06-127815BP	2003IRC	Two-story SFR with attached garage	Plan: 2706	2006
New	Approved Basic 06 127435 BP - 2003 IRC		Two-story SFR with attached garage	Plan: 31	2006
New	Two story SFR with attached Garage				2006
New	Two story SFR with attached Garage				2006
New	Two story SFR with attached Garage (Breckendale A )				2006
New	Two-story sfr with attached garage				2006
New	Two-story sfr with attached garage				2006
New	Two-story sfr with attached garage				2006
New	Two story SFR with attached Garage				2006
New	Two-story SFR	2003 IRC		Builder s Plan: Preston B	2006
New	Two-story SFR	2003 IRC		Builder s Plan: Brooke A	2006
New	2 story SFR w/ attached 3 car garage				2006
New	Approved Basic 06 127435 BP - 2003 IRC		Two-story SFR with attached garage	Plan: 31	2006
New	Approved Basic 05-118728BP	2003 IRC	2 story SFR w/attached garage	Plan:3:	2006
New	Approved Basic 05-118736BP	2003 IRC	2 story SFR w/attached garage	Plan:2999w/	2006
New	Approved Basic 05-118736BP	2003 IRC	2 story SFR w/attached garage	Plan:2999w/	2006
New	Approved Basic 05-118728BP	2003 IRC	2 story SFR w/attached garage	Plan:3:	2006
New	Approved Basic 05-118732BP	2003 IRC	2 story SFR w/attached garage	Plan:3007	2006
New	Approved Basic 05-118736BP	2003 IRC	2 story SFR w/attached garage	Plan:2999w/	2006
New	Approved Basic 05-118736BP	2003 IRC	2 story SFR w/attached garage	Plan:2999w/	2006
New	Approved Basic 05-118728BP	2003 IRC	2 story SFR w/attached garage	Plan:3:	2006
New	Approved Basic 06 127435 BP - 2003 IRC		Two-story SFR with attached garage	Plan: 31	2006
New	Approved Basic 05-118728BP	2003 IRC	2 story SFR w/attached garage	Plan:3:	2006
New	Approved Basic 06-127815BP	2003IRC	Two-story SFR with attached garage	Plan: 2706	2006
New	Approved Basic 05-118736BP	2003 IRC	2 story SFR w/attached garage	Plan:2999w/	2006
New	Approved Basic 05-118734BP	2003 IRC	2 story SFR w/attached garage	Plan:2999w/	2006
New	Approved Basic 05-118736BP	2003 IRC	2 story SFR w/attached garage	Plan:2999w/	2006
New	Approved Basic 05-118728BP	2003 IRC	2 story SFR w/attached garage	Plan:3:	2006
New	Approved Basic 05-118736BP	2003 IRC	2 story SFR w/attached garage	Plan:2999w/	2006
New	Approved Basic 05-118741BP	2003 IRC	2 story SFR w/attached garage	Plan:2786\	2006
New	Approved Basic 05-118736BP	2003 IRC	2 story SFR w/attached garage	Plan:2999w/	2006
New	Approved Basic 05-118736BP	2003 IRC	2 story SFR w/attached garage	Plan:2999w/	2006
New	Approved Basic 05-118728BP	2003 IRC	2 story SFR w/attached garage	Plan:3:	2006
New	Approved Basic 06-127811BP	2003IRC	Two-story SFR with attached garage	Plan: 2505	2006
New	Approved Basic 06-127811BP	2003IRC	Two-story SFR with attached garage	Plan: 2505	2006
New	Approved Basic 06-127815BP	2003IRC	Two-story SFR with attached garage	Plan: 2706	2006
New	Approved Basic 05-118736BP	2003 IRC	2 story SFR w/attached garage	Plan:2999w/	2006
New	Approved Basic 05-118741BP	2003 IRC	2 story SFR w/attached garage	Plan:2786\	2006
New	Approved Basic 05-118736BP	2003 IRC	2 story SFR w/attached garage	Plan:2999w/	2006
New	Approved Basic 05-118732BP	2003 IRC	2 story SFR w/attached garage	Plan:3007	2006
New	2-story sfr w/attached garage				2006
New	2-story sfr w/attached garage				2006
New	Approved Basic 05-118728BP	2003 IRC	2 story SFR w/attached garage	Plan:3:	2006
New	Approved Basic 05-118736BP	2003 IRC	2 story SFR w/attached garage	Plan:2999w/	2006



Accessory Dwelling Units

Index # - File Name: 1.0022 - Single Family Dwellings Data\_Snohomish County.pdf

New	Approved Basic 05-118728BP	2003 IRC	2 story SFR w/attached garage	Plan:3;	2006
New	Approved Basic 05-118736BP	2003 IRC	2 story SFR w/attached garage	Plan:2999w/	2006
New	Approved Basic 05-118728BP	2003 IRC	2 story SFR w/attached garage	Plan:3;	2006
New	Approved Basic 05-118736BP	2003 IRC	2 story SFR w/attached garage	Plan:2999w/	2006
New	Approved Basic 05-118736BP	2003 IRC	2 story SFR w/attached garage	Plan:2999w/	2006
New	Approved Basic 05-118728BP	2003 IRC	2 story SFR w/attached garage	Plan:3;	2006
New	Approved Basic 05-118728BP	2003 IRC	2 story SFR w/attached garage	Plan:3;	2006
New	Approved Basic 05-118736BP	2003 IRC	2 story SFR w/attached garage	Plan:2999w/	2006
New	2-story sfr w/attached garage				2006
New	Approved Basic 04-111511BP		Plan 3387-B Two-story SFR - 2003 IRC		2006
New	2-story sfr w/attached garage				2006
New	Approved Basic 05-122242 BP	2003 IRC	Rambler style SFR w/attached garage	Plan: 22'	2006
New	Approved Basic 05-122244BP	2003 IRC	Rambler style SFR w/attached garage	Plan: 244	2006
New	Two story SFR with attached garage				2006
New	Construction of 2598 sq ft SFR with 939 attached garage.				2006
New	Approved Basic 05-118204BP	2003 IRC	2 story SFR w/attached garage	Plan:3	2006
New	Approved Basic 06-101417BP	2003 IRC	2 story SFR w/attached garage	Plan:2505B	2006
New	Two-story Duplex - 2003 IRC	Recorded as	Leah s Estates at Silver Acres No. 6, a Condo	AF# 20C	2006
New	Approved basic 05-123186 BP	2003 IRC	Plan# 2760	2-story sfr w/attached garage	2006
New	2-story sfr w/attached garage				2006
New	2-story sfr w/attached garage				2006
New	2-story sfr w/attached garage				2006
New	2-story sfr w/attached garage				2006
New	2 - story sfr w/attached garage				2006
New	Approved basic 05-122932 BP	2003 IRC	Plan# 9514	2-story sfr w/attached gara	2006
New	Approved basic 06-129045 BP	2003 IRC	Plan# 3105	2-story sfr w/attached garage	2006
New	Approved basic 05-124812 BP	2003 IRC	Plan# 2802 conv	2-story sfr w/attached	2006
New	Approved Basic 05-118728BP	2003 IRC	2 story SFR w/attached garage	Plan:3;	2006
New	Approved basic 06-131354 BP	2003 IRC	Plan# 3210	2-story sfr w/attached gara	2006
New	Approved basic 06-131358 BP	2003 IRC	Plan# 2870	2-story sfr w/attached ga	2006
New	Approved Basic 05-118736BP	2003 IRC	2 story SFR w/attached garage	Plan:2999w/	2006
New	Approved Basic 05-118728BP	2003 IRC	2 story SFR w/attached garage	Plan:3;	2006
New	Approved Basic 05-118736BP	2003 IRC	2 story SFR w/attached garage	Plan:2999w/	2006
New	Approved Basic 05-118732BP	2003 IRC	2 story SFR w/attached garage	Plan:3007	2006
New	Approved Basic 05-118736BP	2003 IRC	2 story SFR w/attached garage	Plan:2999w/	2006
New	Approved Basic 05-118741BP	2003 IRC	2 story SFR w/attached garage	Plan:2786\	2006
New	Approved Basic 05-118736BP	2003 IRC	2 story SFR w/attached garage	Plan:2999w/	2006
New	Approved Basic 05-118736BP	2003 IRC	2 story SFR w/attached garage	Plan:2999w/	2006
New	Approved Basic 05-118736BP	2003 IRC	2 story SFR w/attached garage	Plan:2999w/	2006
New	Approved Basic 05-118741BP	2003 IRC	2 story SFR w/attached garage	Plan:2786\	2006
New	Approved Basic 05-118741BP	2003 IRC	2 story SFR w/attached garage	Plan:2786\	2006
New	Approved Basic 05-118736BP	2003 IRC	2 story SFR w/attached garage	Plan:2999w/	2006
New	To cont. work and inspections from 05-128180RK.	2/21/06 gb	Approved Basic 05-118741BP		2006
New	Approved Basic 05-118728BP	2003 IRC	2 story SFR w/attached garage	Plan:3;	2006
New	Approved Basic 05-118736BP	2003 IRC	2 story SFR w/attached garage	Plan:2999w/	2006

Accessory Dwelling Units

Index # - File Name: 1.0022 - Single Family Dwellings Data\_Snohomish County.pdf

New	Approved Basic 05-118736BP	2003 IRC	2 story SFR w/attached garage	Plan:2999w/	2006
New	Approved Basic 05-118741BP	2003 IRC	2 story SFR w/attached garage	Plan:2786\	2006
New	2-story sfr w/attached garage				2006
New	Approved Basic 05-118740BP	2003 IRC	2 story SFR w/attached garage	Plan:2786	2006
New	Approved Basic 05-118736BP	2003 IRC	2 story SFR w/attached garage	Plan:2999w/	2006
New	Approved Basic 05-118728BP	2003 IRC	2 story SFR w/attached garage	Plan:3\	2006
New	Approved Basic 05-118741BP	2003 IRC	2 story SFR w/attached garage	Plan:2786\	2006
New	Approved Basic 05-118736BP	2003 IRC	2 story SFR w/attached garage	Plan:2999w/	2006
New	Approved Basic 05-118736BP	2003 IRC	2 story SFR w/attached garage	Plan:2999w/	2006
New	Approved Basic 05-118728BP	2003 IRC	2 story SFR w/attached garage	Plan:3\	2006
New	Approved Basic 04-116493BP	2003 IRC	2 story SFR w/attached garage	Plan:2421C	2006
New	Rambler with attached garage				2006
New	Approved Basic 05-128466BP	2003 IRC	2 story SFR w/attached garage	Plan:2531A & C	2006
New	Two story SFR with attached Garage				2006
New	Approved Basic 05-101909BP	2003 IRC		Plan:2234B	2006
New	Approved Basic 05-101920BP	2003 IRC		Plan:2595A	2006
New	Approved Basic 05-101914BP	2003 IRC		Plan:2530A	2006
New	Approved Basic 05-101916BP	2003 IRC		Plan:2994A	2006
New	Approved Basic 05-101912BP	2003 IRC		Plan:2234A	2006
New	Approved Basic 05-101918BP	2003 IRC		Plan:2742A	2006
New	Approved Basic 05-101913BP	2003 IRC		Plan:2530B	2006
New	Approved Basic 05-101912BP	2003 IRC		Plan:2234A	2006
New	Approved Basic 05-101915BP	2003 IRC		Plan:2994B	2006
New	Approved Basic 05-101913BP	2003 IRC		Plan:2530B	2006
New	Approved Basic 05-101919BP	2003 IRC		Plan:2595B	2006
New	Approved Basic 05-101909BP	2003 IRC		Plan:2234B	2006
New	Approved Basic 05-101917BP	2003 IRC		Plan:2742B	2006
New	Approved Basic 05-101914BP	2003 IRC		Plan:2530A	2006
New	Approved Basic 05-101916BP	2003 IRC		Plan:2994A	2006
New	Approved Basic 05-101912BP	2003 IRC		Plan:2234A	2006
New	Approved Basic 05-101919BP	2003 IRC		Plan:2595B	2006
New	Approved Basic 06-100867BP	2003 IRC	2 story SFR w/attached garage	Plan:3421B	2006
New	Approved Basic 05-129015BP	2003 IRC	2 story SFR w/attached garage	Plan:2411C	2006
New	Approved Basic 04-116493BP		Plan: 2421 C Two-story SFR with attached		2006
New	Approved Basic 05-116878BP		2003 IRC Plan: 3370-3		2006
New	Approved Basic 05-116878BP	2003 IRC	Plan: 3370-3 Two story SFR with Attach		2006
New	Approved Basic 06-133789 BP	2003 IRC	Plan: 3237-3 Two story SFR with attached C		2006
New	Approved Basic 06-102894BP	2003 IRC	2 story SFR w/attached garage	Plan:34C	2006
New	Approved Basic 05-116878BP		2003 IRC Plan: 3370-3		2006
New	Approved basic 05-101398 BP	2003 IRC	Plan # 3259-3 2 story sfr w/attached garag		2006
New	Approved basic #06-101302 BP		Plan:3286 2-story w/garage - 2003 IRC code		2006
New	Approved basic 05-127356 BP	2003 IRC	Plan# 2306 A&B 2-story sfr w/attache		2006
New	Approved Basic 05-100213BP	2003 IRC	Plan: 2640 A & B Two-story SFR wit		2006
New	Approved Basic 04-116427BP		Plan: 3512 A & B Two-story SFR with attach		2006
New	Approved Basic 04-111502BP		Plan 2863-A Two-story SFR - 2003 IR		2006
New	Approved Basic 06-101106BP	2003 IRC	2 story SFR w/attached garage	Plan 3061AB	2006
New	Approved Basic 04-118859BP	2 story SFR w/attached garage	2003 IRC	Plan:4063AB	2006

Accessory Dwelling Units

Index # - File Name: 1.0022 - Single Family Dwellings Data\_Snohomish County.pdf

New	Approved Basic 05-121636BP	2003 IRC	2 story SFR w/attached garage	Plan:4055A	2006
New	Approved Basic 04-118859BP	2003 IRC	2 story SFR w/attached garage	Plan:4063AB	2006
New	Approved Basic 06-101106BP	2003 IRC	2 story SFR w/attached garage	Plan 3061AB	2006
New	Approved Basic 04-118858BP	2003 IRC	2 story SFR w/attached garage	Plan:4062AB	2006
New	Approved Basic 04-116177BP		Builders plan# 2575-A&B	2-Story SFR w/atta	2006
New	Approved Basic 04-114926BP	2003 IRC	2 story SFR w/attached garage	Plan 2451A & B	2006
New	Approved Basic 04-112274BP	2003 IRC	2 story SFR w/ attached garage	Plan#2205 A & B	2006
New	Approved Basic 04-112274BP	2003 IRC	2 story SFR w/ attached garage	Plan#2205 A & B	2006
New	Approved basic 05-127356 BP	2003 IRC	Plan# 2306 A&B	2-story sfr w/attache	2006
New	Approved Basic 04-111510BP		Plan 3387-A	Two-story SFR - 2003 IRC	2006
New	Approved Basic 04-116427BP		Plan: 3512 A & B	Two-story SFR with attach	2006
New	Approved Basic 04-111506BP		Plan: 2863-C	Two-story SFR - 2003 IRC	2006
New	Approved Basic 04-111510BP		Plan 3387-A	Two-story SFR - 2003 IRC	2006
New	Approved Basic 04-111510BP		Plan 3387-A	Two-story SFR - 2003 IRC	2006
New	Approved Basic 04-111506BP		Plan: 2863-C	Two-story SFR - 2003 IRC	2006
New	Approved Basic 04-116177BP		Builders plan# 2575-A&B	2-Story SFR w/atta	2006
New	Approved Basic 05-100687BP	2003 IRC		Plan: 2112 A&B	2006
New	Approved Basic 04-112274BP	2003 IRC	2 story SFR w/ attached garage	Plan#2205 A & B	2006
New	Approved Basic 05-100687BP	2003 IRC		Plan: 2112 A&B	2006
New	Approved basic 05-116239BP	2003 IRC	Plan: 2863C-3 car	2 story sfr w/attached g	2006
New	Approved Basic 05-100687BP	2003 IRC		Plan: 2112 A&B	2006
New	Approved Basic 05-100687BP	2003 IRC		Plan: 2112 A&B	2006
New	Approved Basic 05-100687BP	2003 IRC		Plan: 2112 A&B	2006
New	Approved Basic 04-114926BP	2003 IRC	2 story SFR w/attached garage	Plan 2451A & B	2006
New	Approved Basic 04-116177BP		Builders plan# 2575-A&B	2-Story SFR w/atta	2006
New	Approved Basic 04-116177BP		Builders plan# 2575-A&B	2-Story SFR w/atta	2006
New	Approved Basic 04-111506BP		Plan: 2863-C	Two-story SFR - 2003 IRC	2006
New	Approved Basic 04-116177BP		Builders plan# 2575-A&B	2-Story SFR w/atta	2006
New	Approved Basic 04-116177BP		Builders plan# 2575-A&B	2-Story SFR w/atta	2006
New	Approved Basic 04-116177BP		Builders plan# 2575-A&B	2-Story SFR w/atta	2006
New	Approved Basic 04-111511BP		Plan 3387-B	Two-story SFR - 2003 IRC	2006
New	Approved basic 05-127356 BP	2003 IRC	Plan# 2306 A&B	2-story sfr w/attache	2006
New	Approved Basic 04-116177BP		Builders plan# 2575-A&B	2-Story SFR w/atta	2006
New	Approved Basic 04-111511BP		Plan 3387-B	Two-story SFR - 2003 IRC	2006
New	Approved Basic 04-114926BP	2003 IRC	2 story SFR w/attached garage	Plan 2451A & B	2006
New	Approved Basic 06-102761BP	2003 IRC	2 story SFR w/attached garage	Plan:3063	2006
New	Approved Basic 06-101026BP	2003 IRC	2 story SFR w/attached garage	Plan:FL3063B	2006
New	Approved Basic 04-121305BP	2003 IRC	2 story SFR w/attached garage	Plan:3060AB	2006
New	Approved Basic 06-101025BP	2003 IRC	2 story SFR w/attached garage	Plan:FL3063A	2006
New	Approved Basic 04-121305BP	2003 IRC	2 story SFR w/attached garage	Plan:3060AB	2006
New	Approved Basic 06-101025BP	2003 IRC	2 story SFR w/attached garage	Plan:FL3063A	2006
New	Approved Basic 06-102439BP	2003 IRC	2 story SFR w/attached garage	Plan:4044A	2006
New	Approved Basic 06-103360BP	2003 IRC	2 story SFR w/attached garage	Plan:3840C	2006
New	Approved Basic 05-100687BP	2003 IRC		Plan: 2112 A&B	2006
New	Approved Basic 06-102439BP	2003 IRC	2 story SFR w/attached garage	Plan:4044A	2006
New	Approved Basic 06-102439BP	2003 IRC	2 story SFR w/attached garage	Plan:4044A	2006
New	Approved Basic 06-103358BP	2003 IRC	2 story SFR w/attached garage	Plan:3840A	2006

Accessory Dwelling Units

Index # - File Name: 1.0022 - Single Family Dwellings Data\_Snohomish County.pdf

New	Approved Basic 06-102439BP	2003 IRC	2 story SFR w/attached garage	Plan:4044A	2006
New	Approved Basic 06-103360BP	2003 IRC	2 story SFR w/attached garage	Plan:3840C	2006
New	Approved Basic 05-121637BP	2003 IRC	2 story SFR w/attached garage	Plan:4055B	2006
New	Approved Basic 06-101106BP	2003 IRC	2 story SFR w/attached garage	Plan 3061AB	2006
New	Approved Basic 06-101026BP	2003 IRC	2 story SFR w/attached garage	Plan:FL3063B	2006
New	Approved Basic 06-101106BP	2003 IRC	2 story SFR w/attached garage	Plan 3061AB	2006
New	Approved Basic 06-101025BP	2003 IRC	2 story SFR w/attached garage	Plan:FL3063A	2006
New	Approved Basic 06-101106BP	2003 IRC	2 story SFR w/attached garage	Plan 3061AB	2006
New	Approved basic 05-121434 BP	2003 IRC	Plan# 3052A	2-story sfr w/attached garage	2006
New	Approved Basic 04-118858BP	2003 IRC	2 story SFR w/attached garage	Plan:4062AB	2006
New	Approved Basic 04-121596BP	2003 IRC	2 Story SFR w/attached garage	Plan:4044ABC	2006
New	Approved Basic 04-121745BP	2003 IRC	2 Story SFR w/attached garage	Plan:4040AB	2006
New	Approved Basic 04-121596BP	2003 IRC	2 Story SFR w/attached garage	Plan:4044ABC	2006
New	Approved Basic 04-121745BP	2003 IRC	Plan:4040AB	2 Story SFR w/att	2006
New	Approved Basic 06-102439BP	2003 IRC	2 story SFR w/attached garage	Plan:4044A	2006
New	SENT PERMIT FOLDER TO RECORDS ROOM 10/9/08 DM Approved Basic 04-121596BP 2 Story :				2006
New	Approved Basic 04-118858BP	2003 IRC	2 story SFR w/attached garage	Plan:4062AB	2006
New	Approved Basic 04-121745BP	2003 IRC	2 Story SFR w/attached garage	Plan:4040AB	2006
New	Approved Basic 04-121596BP	2003 IRC	2 Story SFR w/attached garage	Plan:4044ABC	2006
New	Approved Basic 04-118858BP	2003 IRC	2 story SFR w/attached garage	Plan:4062AB	2006
New	Approved basic 05-124333 BP	2003 IRC	Plan# 1733	2-story sfr w/attached garage	2006
New	Approved basic 05-124337 BP	2003 IRC	Plan# 1552	2-story sfr w/attached garage	2006
New	Approved basic 05-124333 BP	2003 IRC	Plan# 1733	2-story sfr w/attached garage	2006
New	Approved basic 05-124337BP	2003 IRC	Plan #1552	2-story sfr w/attached garage	2006
New	Approved basic 05-124332 BP	2003 IRC	Plan# 1763	2-story sfr w/attached gara	2006
New	Approved basic 05-125965 BP	2003 IRC	Plan# 150-03 F	2-story sfr w/attached gara	2006
New	Approved basic 05-125966 BP	2003 IRC	Plan# 110-03 F	2-story sfr w/attached gara	2006
New	PERMIT OWNERSHIP TRANSFERRED FROM RICHARD DEMPSEY TO M.D. JONES 4/18/06 ssullivan				2006
New	Approved Basic 06-129955 BP	2003 IRC	Plan: 3331	Two story SFR with attached Garag	2006
New	Approved Basic 06-102894BP	2003 IRC	2 story SFR w/attached garage	Plan:34	2006
New	Two-story SFR	2003 IRC	Builder s Plan 3553		2006
New	Apprved basic #06-101302 BP		Plan:3286 2-story w/garage - 2003 IF		2006
New	Approved Basic #05-124117 BP	2003 IRC	2 story SFR w/attached garage	Plan:3101	2006
New	Two story SFR with attached Garage				2006
New	Approved basic #06-101302 BP		Plan:3286 2-story w/garage - 2003 I		2006
New	Approved Basic 05-116370BP	2003 IRC	Plan:108	2 story SFR w/attached g	2006
New	61 x 40 two story SFR				2006
New	Approved Basic 05-117703BP	2003 IRC	Plan:350-13A	2 story SFR w/attached garage	2006
New	Approved basic 05-125966 BP	2003 IRC	Plan# 110-03 F	2-story sfr w/attached gara	2006
New	2003 IRC	Plan# 150-03 F	2-story sfr w/attached garage		2006
New	Approved Basic 05-101076BP	2003 IRC	Plan:210		2006
New	**** 2 yr. RENEWAL ****Two-story SFR w/Attached Accessory Apartment - 1997 UBC				2006
New	One-story SFR				2006
New	2-story SFR w/garage				2006
New	2148 sq ft Rambler with attached Garage				2006
New	SFR Rambler with 4-car garage				2006
New	2-story SFR w/garage				2006

Accessory Dwelling Units

Index # - File Name: 1.0022 - Single Family Dwellings Data\_Snohomish County.pdf

New	2600 sq ft Rambler with attached Garage				2006
New	2-story SFR w/garage				2006
New	Two story SFR with finished Basement & attached Garage				2006
New	Approved basic 06-102967 BP	2003 IRC	Plan # 1910	Split level sfr w/attached	2006
New	Approved basic 06-102967 BP	2003 IRC	Plan # 1910	Split level sfr w/attached	2006
New	2006 66 X 27 Doublewide MH				2006
New	27 x 66 1989 Marlette				2006
New	2006 70 X 40 Triplewide MH				2006
New	SENT PERMIT FOLDER TO RECORDS ROOM 10/15/08 DM Rambler w/ attached 3 car garage				2006
New	** CLOSED - FINISHING ATTIC UNDER NEW PERMIT NUMBER: 07-113204-RK **2-Story SFR w/at				2006
New	REVERSED EXPIRED STATUS TO FINAL PER INSPECTION CARD RECEIVED FROM LESLIE RUITER ON				2006
New	2-Story SFR w/attached garage.				2006
New	Two-story residence with attached garage				2006
New	40 x 70 - 2006 Fleetwood Mobile Home.				2006
New	Duplex - rambler w/ attached 1 car garage (2 bedrooms per unit)				2006
New	Two-story SFR with attached garage - 2003 IRC				2006
New	Two-story SFR with finished daylight basement & attached garage - 2003 IRC				2006
New	Two-story SFR with attached garage - 2003 IRC				2006
New	Two-story SFR with attached garage - 2003 IRC				2006
New	2-story sfr w/attached garage				2006
New	2 story w/ attchd 2 car garage				2006
New	EXPIRED WITHOUT COUNTY APPROVAL TO USE OR OCCUPY. SENT TO MICROFICHE. 9/16/08 2 s				2006
New	One-story SFR	2003 IRC			2006
New	Rambler w/ attached 3 car garage with bonus room above				2006
New	26 8 X 60 2006 Mobile Home *** Fees paid under 06-125897-00 MH ***				2006
New	Two story SFR with attached Garage				2006
New	2-story SFR w/garage				2006
New	Approved Basic 04-116274BP	2003 IRC	Plan:The HillcrestT		2006
New	2-story w/unfinished basement				2006
New	40x60, 2000 Golden West				2006
New	2 story SFR w/attached garage	2003 IRC			2006
New	2 story SFR w/attached garage	2003 IRC			2006
New	2 story SFR w/attached garage	2003 IRC			2006
New	2 story SFR w/attached garage	2003 IRC			2006
New	2 story SFR w/attached garage	2003 IRC			2006
New	832 SF Detached Guesthouse with Attached Garage with Second Floor Storage NOTE: Lou Scha				2006
New	Single story home with attached Garage				2006
New	Double Wide Marlette 2005 Mobile Home 26 8 x 66				2006
New	Approved Basic 05-127960BP	Plan: 2114	2003 IRC	Two-story SFR with attac	2006
New	Approved basic 05-126654 BP	2003 IRC	Plan # 2009-3-55	2-story sfr w/attached gar	2006
New	Two-story residence with attached garage				2006
New	Rambler with attached garage				2006
New	Two-story residence with attached garage and shop				2006
New	2896 sq ft Rambler with attached Garage				2006
New	1214 sq ft SFR & 552 sq ft Semi finished Basement with attached Garage				2006
New	1214 sq ft SFR & 552 sq ft Semi Finished Basement with attached Garage				2006
New	One-story SFR		Builders Plan: 2709		2006

Accessory Dwelling Units

Index # - File Name: 1.0022 - Single Family Dwellings Data\_Snohomish County.pdf

New	Two-story SFR with attached 3-car garage - 2003 IRC	2006
New	SFR with 1576 SF Finished Basement and Attached Garage	2006
New	2-story SFR w/garage	2006
New	Two story SFR with attached Garage	2006
New	Two-story residence with attached garage	2006
New	Rambler style w/unfinished basement and attached garage	2006
New	1632sf rambler with attached garage - 2003 IRC	2006
New	Approved basic 05-126654 BP 2003 IRC Plan # 2009-3-55 2-story sfr w/attached gar	2006
New	Approved Basic 05-121468 BP 2003 IRC Plan: 2022-3-55 202	2006
New	Approved Basic 05-121468 BP 2003 IRC Plan: 2022-3-55 202	2006
New	Pending Basic 05-121468 BP 2003 IRC Plan: 2022-3-55 2022	2006
New	Approved Basic 06-101863 BP 2003 IRC Plan: 1361-2 Two-story SFR with attach	2006
New	Approved basic 05-126654 BP 2003 IRC Plan # 2009-3-55 2-story sfr w/attached gar	2006
New	1680 Sq Ft Rambler	2006
New	Rambler with attached garage	2006
New	2 story home with attached 3 car garage	2006
New	Two story SFR 2003 IRC	2006
New	Two-story residence with attached garage	2006
New	2-story SFR w/garage & covered deck	2006
New	2-Story SFR w/attached garage.	2006
New	3970 sq. ft. 2 story SFR with attached 1174 sq.ft. garage	2006
New	2195sf SFR with 1439sf finished daylight basement - 2003 IRC	2006
New	2 story SFR w/ attached 3 car garage	2006
New	Two story SFR with finished basement	2006
New	835 sf. private office (with seperate entrance) + 1325 sf garage/shop + 1440 sf covered porche	2006
New	791 Accessory Apartment with attached Garage	2006
New	3072 sq ft SFR	2006
New	SFR with Attached Garage	2006
New	2-Story SFR w/finished daylight basement & attached garage.	2006
New	Multi-level SFR w/garage	2006
New	Rambler style SFR	2006
New	Rambler Style SFR w/attached garage w/bonus room above.	2006
New	Approved Basic 05-122089BP 2003 IRC Rambler w/attached garage Plan 1764	2006
New	1950sf 2 story , 4 garage single family residence	2006
New	4425 SFR with 1077 attached garage.	2006
New	14 x 52 1977 Tamarac Mobile Home	2006
New	Two-story sfr with attached garage	2006
New	40x68, 2006, Palm Harbor	2006
New	Two story SFR with attached Garage	2006
New	2820 sq ft SFR	2006
New	2-story sfr w/attached garage	2006
New	Two-story SFR	2006
New	Convert Existing 800 SF SFR to Detached Accessory Apt	2006
New	Rambler style SFR w/garage	2006
New	SENT PERMIT FOLDER TO RECORDS ROOM 10/23/08 DM 849 sq. ft. Lindal Cedar home with 58:	2006
New	Two story SFR with attached Garage	2006
New	2006 Triple-wide MH	2006

Accessory Dwelling Units

Index # - File Name: 1.0022 - Single Family Dwellings Data\_Snohomish County.pdf

New	2-story sfr w/attached garage		2006
New	Two story SFR with attached Garage		2006
New	Two-story SFR	2003 IRC	2006
New	Two-story sfr with attached garage & daylight basement (semi-finished)		2006
New	2281sq ft SFR with 1436 sq ft unfinished basement.		2006
New	Two-story SFR	2003 IRc	2006
New	Rambler with attached garage		2006
New	Two story sfr with attached garage		2006
New	2-story daylight basment w/attached garage		2006
New	2006 Palm Harbour Discovery 59 x 64 with two pods		2006
New	Duplex		2006
New	Approved Basic 04-117111BP	Plan: 2471	Two-story SFR with attached ga 2006
New	2-story SFR w/garage & covered porch		2006
New	Triple-wide Mobile Home		2006
New	Two-story residence with attached garage		2006
New	Two-story sfr with attached garage		2006
New	41 ft x 95 ft two story SFR with attached garage		2006
New	Two story SFR with attached Garage		2006
New	Two story SFR with semi-finished basement.		2006
New	2-story sfr w/attached garage		2006
New	2- story duplex		2006
New	Two-story SFR	2003 IRC	2006
New	2 story SFR w/ attached 2 car garage		2006
New	2 story home SFR w/ attached 2 car garage		2006
New	27x48, 2006 Golden West GE 48F		2006
New	2-Story SFR w/attached garage		2006
New	Two story SFR with attached Garage		2006
New	28 x 66 1992 Fleetwood		2006
New	Rambler w/ attached 3 car garage		2006
New	Rambler style SFR w/attached garage.		2006
New	2 story SFR w/ attached 3 car garage		2006
New	SENT PERMIT FOLDER TO RECORDS ROOM 10/15/08 DM	2-Story SFR over finished basement w	2006
New	2 story Duplex	2003 IRC	2006
New	3280 sq ft SFR with 815 sq ft attached garage.		2006
New	1221 sq ft SFR with 462 sq ft attached garage.		2006
New	Approved Basic #04-119796 BP	Plan #969 x 40	2 story SFR with att 2006
New	Two-story sfr with attached garage		2006
New	Repair of Fire Damage to SFR		2006
New	Two-story sfr with attached garage		2006
New	2-Story SFR over finished daylight basement		2006
New	14 x 50 Mobile Home as Accessory Apartment		2006
New	2393 sq ft Rambler with attached Garage		2006
New	2960 sq ft Rambler with attached Garage		2006
New	Accessory Apt. - Split entry w/ unfinished basement & attchd. 1 car garage		2006
New	Two story SFR with attached Garage		2006
New	Convert 1986 Temporary Dwelling to Accessory Apartment		2006
New	27 x 48 - 2006 Double wide Fleetwood Mobile Home		2006

Accessory Dwelling Units

Index # - File Name: 1.0022 - Single Family Dwellings Data\_Snohomish County.pdf

New	Two story SFR with attached Garage				2006
New	2-Story SFR w/attached garage.				2006
New	Two-story residence with attached garages				2006
New	2-story SFR w/garage				2006
New	2 story SFR w/ attached 2 car garage				2006
New	Two story SFR with attached Garage				2006
New	Rambler style SFR with attached 2 car garage				2006
New	2-story SFR w/semi-finished basement & garage				2006
New	1st floor garage w/2nd floor SFR				2006
New	2363 sq ft Rambler with attached Garage				2006
New	Approved Basic 06-126410BP	Two Story SFR with Attached Garage		Plan: 2648	2006
New	Rambler style SFR w/garage & unfinished basement				2006
New	2006 -- 68 X 40 6 Golden West Triplewide				2006
New	Rambler style sfr w/attached garage				2006
New	Two-story SFR	2003 IRC			2006
New	53 x 73 two story SFR with finished basement and attached garage				2006
New	Two-story residence with attached garage				2006
New	Two-story SFR				2006
New	Approved basic 05-124305 BP	2003 IRC	Plan# 0123	2-story sfr w/attached gar	2006
New	784 sf garage with 840 sf residence on 2nd floor				2006
New	2-Story SFR w/attached garage				2006
New	2-story SFR w/ garage				2006
New	Approved Basic #04-115978BP - Plan R-2009-3 - Two Story SFR with Attached Garage - 2003				2006
New	2 story SFR w/ attached 3 car garage				2006
New	Approved Basic 06-103945 BP	2003 IRC		Plan 1707 Split	2006
New	Approved Basic 06-103945 BP	2003 IRC		Plan 1707 Split	2006
New	Two-story residence with attached garage				2006
New	Two story SFR with attached Garage				2006
New	2-story sfr w/attached garage				2006
New	Approved Basic 05-100241BP	2003 IRC	Plan: 1561	2 story Duplex w/attached ga	2006
New	Approved Basic 04-111161BP	2003 IRC	Plan: 1932	Two-story SFR w/attached ga	2006
New	Approved Basic 04-111161BP	2003 IRC	Plan: 1932	Two-story SFR w/attached ga	2006
New	Two Story SFR				2006
New	3663 sq. ft. SFR with garage				2006
New	2 story home w/ finished basement & attached garage				2006
New	2293 sq ft Ramber with Daylight Basement & attached Garage				2006
New	Rambler w/ attchd 3 car garage				2006
New	4,244 sq ft SFR with 530 attached garage.				2006
New	2250 rambler with attached garage - 2003 IRC				2006
New	2-story SFR over daylight finished basement.				2006
New	Rambler style w/unfinished basement - 1997 UBC				2006
New	1998 Champion Sequoia				2006
New	CORRECTED PERMIT see info screen	2-story w/ basement & garage			2006
New	2524 sf rambler with attached garage - 2003 IRC				2006
New	Two-story sfr with attached garage				2006
New	850 sf rambler style detached accessory apartment				2006
New	2006 Marlette Pacifica 66 x 27				2006



Accessory Dwelling Units

Index # - File Name: 1.0022 - Single Family Dwellings Data\_Snohomish County.pdf

New	Two-story residence with 203 sf loft	2006
New	2263 sq ft Rambler with attached Garage	2006
New	2003 Fleetwood 27 x 56	2006
New	Two story SFR with attached Garage	2006
New	2-Story SFR with Attached Garage	2006
New	784-Sq. Ft. Detached Accessory Apartment.	2006
New	2750 sf Rambler with attached garage - 2003 IRC	2006
New	Two-story SFR with attached garage	2006
New	1638 sq ft Rambler with attached Garage	2006
New	Approved Basic 06-103619 -BP 2003 IRC Plan 1752 2-story SFR w/attached garage	2006
New	Rambler w/ attached 2 car Garage	2006
New	32 ft x 55 ft SFR with attached garage	2006
New	30 x 70 - 2004 Marlette - Mobile home.	2006
New	Two story SFR with attached Garage	2006
New	Two-story single family residence	2006
New	New double wide Mobile Home, Kartsen 26 x 60	2006
New	2 story home w/ attached Garage	2006
New	Two Story SFR with Attached Deck	2006
New	2-Story SFR w/attached garage.	2006
New	2640 sq ft SFR w/ 432 sq ft covered porch and 272 covered walkway to garage. (Reference 06-:	2006
New	2-story w/garage	2006
New	Double wide MH, 2006, 27 x 52 to be used as an Accessory Apartment	2006
New	2280 sq ft SFR with 1500 sq ft finished Basement & 720 sq ft unfinished Basement with attached	2006
New	2 story SFR w/ attchd 3 car garage	2006
New	Two story Duplex with attached Garage	2006
New	2006 Marlette Pacifica Mobile Home	2006
New	2550 sq. ft. rambler with finished daylight basement and 496 sq. ft. attached garage	2006
New	2 story home with daylight basement and attached Garage	2006
New	Single story w/ semi finished basement & 1 car garage	2006
New	2 story Duplex w/ attchd Garage	2006
New	802.4 SF Detached Accessory Apt Over 802.4 SF Detached Garage	2006
New	Rambler style SFR	2006
New	Approved Basic 05-122089BP 2003 IRC Rambler w/attached garage Plan 1764	2006
New	Rambler w/ attached 2 car garage	2006
New	Rambler style w/garage & unfinished basement	2006
New	Two story SFR with attached Garage	2006
New	2720 sq ft Rambler with attached Garage	2006
New	One-story sfr with attached garage	2006
New	Rambler style sfr w/attached garage	2006
New	Rambler with attached garage	2006
New	Two story SFR above Garage	2006
New	Rambler style SFR w/attached garage replacing existing mobile home.	2006
New	2-story SFR w/garage	2006
New	2-story single-family residence w/garage	2006
New	Rambler style sfr w/attached garage	2006
New	Two-story sfr with attached garage	2006
New	1380sf Rambler with attached garage - 2003 IRC	2006

Accessory Dwelling Units

Index # - File Name: 1.0022 - Single Family Dwellings Data\_Snohomish County.pdf

New	Two-story SFR over garage	2003 IRC	2006
New	Two-story SFR with unfinished basement	2003 IRC	2006
New	1050 sq ft SFR with finished Basement & attached Garage		2006
New	Split level home w/ unfinished lower floor & attached 2 car garage		2006
New	27 x 34 - 2005 - Marlette Mobile home.		2006
New	2004sf SFR Rambler - 1997UBC	3 bedroom design	2006
New	14 x 66 - 1985 Fleetwood Mobile Home		2006
New	1923 sq ft SFR with 430 attached garage.		2006
New	1050 sq ft SFR & 492 finished Basement with attached Garage		2006
New	22 ft x 40 ft SFR with attached garage		2006
New	rambler style w/finished basement		2006
New	Two Story SFR with Attached Garage. STOP WORK 3/23/06. FAILURE TO COVER STOCKPILES, DI		2006
New	Rambler with attached garage		2006
New	Two story SFR with attached Garage		2006
New	2-Story SFR w/attached garage.		2006
New	40 x 60 2006 Fleetwood Festival 4604P		2006
New	2006 26 X 66 sq ft Fleetwood Festival MH		2006
New	2964 sq ft single family residence with 600 sq ft covered patio connecting existing detached gar		2006
New	Two story SFR with attached Garage		2006
New	Rambler with attached garage and unfinished bonus room above garage		2006
New	28x66, 2006 Fleetwood ***Owner emailed me their final signed off inspection card (Ralph Wall		2006
New	2 story home w/ unfinished basement and attached 3 car garage		2006
New	Two story SFR with attached Garage		2006
New	2007 28 ft x 66 ft Mobile Home, to be used as Accessory Apartment		2006
New	2-Story SFR w/attached garage.		2006
New	46 x 54 2 story SFR with garage attached by breezeway		2006
New	2005 Mobile home 27 x 57		2006
New	1728 sq ft Rambler with attached Garage		2006
New	New 40 ft x 72 ft triplewide MH		2006
New	2005 24 X 30 Double-wide MH to be used for Accessory Apartment		2006
New	Approved BASIC 06-132047-BP	2003 IRC Plan#1790 Rambler Style SFR w/attached gar	2006
New	Single Family Farmhouse - 27 x 66 2005 Palm Harbor Mobile Home		2006
New	Approved Basic 04-120024	Plan Northridge rambler style w/3 car garage - 2003 IRC	2006
New	Two-story duplex with attached garages		2006
New	Two-story residence		2006
New	Construction of 2700 sq ft SFR w/ 640 attached garage.		2006
New	Rambler w/ bonus room above attached 2 car garage		2006
New	Rambler style SFR w/garage		2006
New	Two-story sfr with attached garage		2006
New	Two story SFR with attached Garage		2006
New	Two-story sfr with garage attached by a covered breezeway		2006
New	3188 square foot two story SFR with 883 square foot covered porch		2006
New	1164 sf SFR - 2003 IRC		2006
New	Two-story sfr with attached garage		2006
New	Two story SFR		2006
New	Rambler-style SFR - 2003 IRC		2006
New	38 x 51 two story SFR with attached garage		2006

Accessory Dwelling Units

Index # - File Name: 1.0022 - Single Family Dwellings Data\_Snohomish County.pdf

New	Rambler style SFR w/basement			2006
New	Approved Basic #04-115978BP		Plan R-2009-3 Two Story SFR with Att	2006
New	Two-story sfr with attached garage			2006
New	2694 sq ft SFR with Attached Garage			2006
New	Rambler with attached garage			2006
New	Rambler with Attached Garage			2006
New	Two Story SFR with Attached Garage			2006
New	27 x 52 double wide mobile for Accessory Apartment.			2006
New	Rambler style w/garage, carport, & covered deck			2006
New	2005 Fleetwood Mobile Home - to be used for AA			2006
New	Two Story SFR with 724 SF Finished Basement			2006
New	1580 sq ft Rambler with attached Garage			2006
New	2005 Homebuilders Northwest, Inc. Mobile Home			2006
New	2268 sq ft Rambler with attached Garage			2006
New	842 sq ft Accessory Apartment			2006
New	1440 sq ft SFR with 480 sq ft attached garage.			2006
New	Two- story cabin			2006
New	Two-story residence with attached garage			2006
New	PERMIT TRANSFERRED FROM HOMEPRO CONSTRUCTION PER THEIR REQUEST 3/10/06. gb Two			2006
New	Two story SFR with finished Basement & attached Garage			2006
New	Single family residence with 2nd-floor bonus room and attached garage			2006
New	Rambler with attached garage			2006
New	Two story SFR with attached Garage			2006
New	Two-story single family residence with attached garage			2006
New	New home, one story with attached 2 car, attached garage			2006
New	Two Story SFR with Attached Garage			2006
New	24 x 40 Dbl wide Mobile home			2006
New	2-story SFR w/garage			2006
New	Approved Basic 04-117192BP	2003 IRC	Plan 2225 - 3 Car Ram	2006
New	SFR with finished daylight basement - 2003 IRC			2006
New	Rambler w/ attchd 2 car garage			2006
New	2714 sq ft detached garage with 850 sq ft Guest Quarters on second floor.			2006
New	Approved Basic 06-125093-BP	2003 IRC	2 story SFRw/attached garage Plan: 2802	2006
New	Two story SFR with attached Garage			2006
New	Rambler with attached garage			2006
New	Rambler style SFR with attached garage - 2003 IRC			2006
New	Rambler with Attached Garage			2006
New	Two story SFR with attached Garage			2006
New	Two--story SFR	2003 IRC		2006
New	Rambler with attached 3 car garage			2006
New	2006 27 X 62 Doublewide MH			2006
New	2006 Nashua-Villa Mobile Home			2006
New	Two story SFR with attached Garage			2006
New	3144 sq ft single family residence with 1726 sq ft attached garage.			2006
New	Two-story residence with attached garage			2006
New	1556 sq ft Rambler			2006
New	1995 28 X 56 Doublewide MH			2006

Accessory Dwelling Units

Index # - File Name: 1.0022 - Single Family Dwellings Data\_Snohomish County.pdf

New	Two-story SFR		Builder s Plan: 1752	2006
New	1755 sf Rambler - 2003 IRC			2006
New	2-Story SFR over basement garage/shop.			2006
New	664-sq. ft. accessory apartment over a 26 x 36 detached garage.			2006
New	Rambler w/ attchd 2 car garage			2006
New	Rambler style w/finished basement			2006
New	Two-story SFR			2006
New	Rambler with attached garage			2006
New	1492 sq ft Rambler with attached Garage			2006
New	Approved Basic 06-125665-BP	2003 IRC	1-Story w/attached garage Plan: 357:	2006
New	Approved Basic #06-131577 BP	2003 IRC	Plan:1289 - Split	2006
New	850 sq ft detached Accessory Apartment with attached Garage			2006
New	Rambler with Attached Garage			2006
New	Two story SFR			2006
New	Rambler with Attached Garage			2006
New	Daylight basement Rambler w/finished basement & attached garage.			2006
New	Basement Rambler w/finished basement & attached garage.			2006
New	Approved Basic #06-131577 BP	2003 IRC	Plan:1289 - Split	2006
New	2,700 sf Rambler with attached garage			2006
New	1,744 sf residence with 200 sf loft			2006
New	Two-story SFR with attached garage - 2003 IRC			2006
New	1841 sq ft Rambler with attached Garage			2006
New	1000 sq. ft. SFR over 1000 sq. ft. garage.			2006
New	2-Story SFR w/attached garage.			2006
New	1040 sq ft Garage with 1040 finished 2nd floor. Upper floor finished as two storage rooms, sou			2006
New	2 story SFR w/ attchd 3 car garage			2006
New	2006 Golden West 60 x 42			2006
New	Two-story sfr with attached garage			2006
New	Two-story sfr with attached garage			2006
New	Two-story sfr with attached garage			2006
New	One-story SFR w/attached garage			2006
New	Rambler style SFR with attached garage			2006
New	2067 sq ft SFR with 676 attached garage.			2006
New	40 x 53 4 Triple Wide Karsten Mobile Home			2006
New	2 story SFR			2006
New	Two-story sfr with attached garage			2006
New	Two-story residence with attached garage			2006
New	Two-story sfr with attached garage			2006
New	SFR with Attached Garage			2006
New	2006 sq ft SFR with attached 724 sq ft garage.			2006
New	Approved Basic 05-129317BP	2003 IRC	2-story w/attached garage Plan:#1	2006
New	2-Story SFR w/attached garage			2006
New	Single family residence with daylight basement - 2003 IRC			2006
New	Convert 1200 sf of shop and 400 sf of hanger space to Living Area			2006
New	24 x 52 - 1981 - Gibraltar			2006
New	Two story SFR with unfinished Basement			2006
New	Two-story single family residence			2006

Accessory Dwelling Units

Index # - File Name: 1.0022 - Single Family Dwellings Data\_Snohomish County.pdf

New	2-story SFR w/garage	2006
New	Two-story sfr with attached garage	2006
New	2-story w/garage and covered deck/porch	2006
New	Rambler with attached Garage	2006
New	Two SFR with attached Garage	2006
New	2,048sf Rambler w/unfinished daylight bsmnt and attchd 2 car garage	2006
New	caspr 200603281166 28 x 58 2006 Sierra Vista Marlette Mobile Home	2006
New	Two story SFR with attached Garage	2006
New	2-Story SFR w/attached garage.	2006
New	2141 sq ft Rambler with unfinished daylight Basement and attached Garage	2006
New	Rambler style SFR w/garage & unfinished basement	2006
New	Daylight Basement Rambler	2007
New	SFR Two Story with Attached Garage	2007
New	Two-story sfr with attached garage	2007
New	New 680 sq. ft detached Accessory Apartment. (Main SFR is: 1848 sq. ft)	2007
New	Rambler with attached garage	2007
New	Approved Basic No. 07- 108319 Builder s Plan No. 2267 One Story w/ attached 3 car garage	2007
New	Rambler style w/garage	2007
New	Two story SFR with attached Garage	2007
New	Duplex - 2 story w/attached garages	2007
New	SENT PERMIT FOLDER TO RECORDS ROOM 12/01/08 DM Rambler style SFR w/garage	2007
New	2-story Single Family Residence with attached 3-car garage.	2007
New	Rambler with unfinished basement	2007
New	Rambler with attached garage	2007
New	Two story SFR	2007
New	SENT PERMIT FOLDER TO RECORDS ROOM 12/01/08 DM Two story SFR with attached Garage	2007
New	Rambler w/daylight basement single family residence with attached garage.	2007
New	40 ft x 70 ft double-wide mobile home.	2007
New	Two story SFR with 1196 sq ft unfinished Basement & attached two story Garage	2007
New	2840 sq ft SFR	2007
New	SENT PERMIT FOLDER TO RECORDS ROOM 11/21/08 DM Two story SFR with attached Garage	2007
New	2-Story SFR w/attached garage.	2007
New	Two-story SFR with attached garage - 2003 IRC	2007
New	Rambler	2007
New	Two-story SFR with unfinished basement and attached garage - 2003 IRC	2007
New	58 ft x 84 ft two story SFR with attached garage	2007
New	New one story sfr w/ attached garage	2007
New	Rambler style w/garage and finished basement	2007
New	SENT PERMIT FOLDER TO RECORDS ROOM 10/28/08 DM 53 ft x 75 ft SFR with attached garage	2007
New	Two Story SFR with Semi Finished Basement	2007
New	SENT PERMIT FOLDER TO RECORDS ROOM 11/24/08 DM Two-story residence	2007
New	SENT PERMIT FOLDER TO RECORDS ROOM 10/15/08 DM Rambler style SFR w/attached garage.	2007
New	Rambler style SFR w/garage	2007
New	SENT PERMIT FOLDER TO RECORDS ROOM 11/21/08 DM 103 ft x 106 ft two story SFR with attached garage	2007
New	52 ft x 61 ft SFR with attached garage	2007
New	Two-story residence with daylight basement and attached garage	2007
New	Two story SFR with attached Garage	2007

Accessory Dwelling Units

Index # - File Name: 1.0022 - Single Family Dwellings Data\_Snohomish County.pdf

New	SENT PERMIT FOLDER TO RECORDS ROOM 12/01/08 DM	2-story SFR w/covered deck/porch	2007
New	Rambler with attached garage		2007
New	2-story sfr w/attached garage		2007
New	2-story SFR w/garage		2007
New	1308 sq ft rambler single family residence with 430 sq ft attached garage.		2007
New	Two story SFR		2007
New	SENT PERMIT FOLDER TO RECORDS ROOM 12/01/08 DM	2-story Single Family Residence w/gar	2007
New	***Do not void - application time extended per Stephanie Lyon 3/8/07 - D Crossman	Conversic	2007
New	Two-story residence with attached garage		2007
New	Rambler, 3 bedroom, 2 bath (no garage)		2007
New	New 2 story SFR w/ attached garage		2007
New	1000 sq ft SFR above 1200 sq ft Garage		2007
New	SFR Rambler w/ attchd 2 car garage (1776 sqft)		2007
New	2 story SFR w/ Attached Garage		2007
New	Daylight basement SFR w/attached garage.		2007
New	SENT PERMIT FOLDER TO RECORDS ROOM 10/22/08 DM	Two story SFR with finished Basement	2007
New	480 sf guest house attached to 624 sf garage and 576sf shop		2007
New	2-story SFR w/garage		2007
New	SENT PERMIT FOLDER TO RECORDS ROOM 12/01/08 DM	2-story SFR w/garage	2007
New	To finish work on expired permit #03-106829 RK for Rambler		2007
New	2 story sfr with finished basement 1685 sq. ft.		2007
New	Changing from a larger SFR to a smaller two story SFR with finished Basement		2007
New	Two-story residence with attached garage		2007
New	New Two Story SFR with attached garage		2007
New	2-story SFR w/ attached carport.		2007
New	2006 West Ridge Mobile home 27 x 56		2007
New	SENT PERMIT FOLDER TO RECORDS ROOM 10/28/08 DM	Replacing destroyed MH with Ramble	2007
New	28 x 64 - 1999 - Redmond Mobile Home.		2007
New	Reversed EXPIRED STATUS - MH has been removed from property 10/25/12 dm	Two story SFR	2007
New	SENT PERMIT FOLDER TO RECORDS ROOM 10/27/08 DM	1-story sfr	2007
New	Detached Accessory Apartment		2007
New	One-story residence with daylight basement		2007
New	Single-wide 1978 Ridgewood Mobile Home		2007
New	Rambler with attached garage		2007
New	27 x 62 2007 Greenbrier Mobile Home		2007
New	SENT PERMIT FOLDER TO RECORDS ROOM 10/15/08 DM	1995 28 X 60 Fleetwood Gilbralter	2007
New	2-story SFR w/garage		2007
New	2-Story single family residence with attached garage		2007
New	Two story SFR with unfinished Basement & attached Garage		2007
New	2553 sq ft single family residence with attached 768 sq ft garage.		2007
New	1991 sq ft Rambler with attached Garage		2007
New	Two story SFR with Unfinished Basement & attached Garage		2007
New	Approved Basic #04-115976BP	Rambler with Attached Garage - 2003 IRC	Plan:R-2022-3
New	Two story SFR with attached Garage		2007
New	2040 sq ft Rambler with attached Garage		2007
New	Rambler style w/ semi finished basement & garage		2007
New	Two story SFR with attached Garage		2007

Accessory Dwelling Units

Index # - File Name: 1.0022 - Single Family Dwellings Data\_Snohomish County.pdf

New	SENT PERMIT FOLDER TO RECORDS ROOM 11/21/08 DM	Two story SFR with attached Garage	2007		
New	SENT PERMIT FOLDER TO RECORDS ROOM 11/26/08 DM	Rambler with attached garage	2007		
New		New one story SFR w/ attached garage (replacing existing mobile)	2007		
New	SENT PERMIT FOLDER TO RECORDS ROOM 11/21/08 DM	Rambler style SFR w/garage	2007		
New		2 story SFR w/ attached 3 car garage	2007		
New		28x66, 1990 Forest Manor	2007		
New		2006 Mobile home 27 x 52 Marlette First Edition to be used as a temporary dwelling	2007		
New		2-story SFR w/attached garage.	2007		
New		2-story SFR w/garage	2007		
New		55 ft x 87 ft two story SFR with attached garage	2007		
New	SENT PERMIT FOLDER TO RECORDS ROOM 10/15/08 DM	Rambler (2,365 sqft)	2007		
New		PERMIT WAS TRANSFERRED FROM LIDIA SANTIESTEBAN TO HARDY R. & KATRINA E. DAVIDSON	2007		
New		2-story w/garage	2007		
New		2-story w/garage	2007		
New	SENT PERMIT FOLDER TO RECORDS ROOM 11/24/08 DM	2-Story SFR w/attached garage.	2007		
New		1986 Fuqua Mobile Home	2007		
New		2 story home with attached 3 car garage (3 bedrooms plus bonus room)	2007		
New		Two-story residence	2007		
New	SENT PERMIT FOLDER TO RECORDS ROOM 10/15/08 DM	2-story sfr w/attached garage	2007		
New	MICRO 6/25/07	Installation of a 924 square foot Cottage building (single wide mobile home).	2007		
New		Mobile home 2006 Fleetwood 40 x 60 triplewide, for a temporary dwelling	2007		
New		Construction of 2262 sq ft single family residence with 484 sq ft attached garage.	2007		
New		Two story SFR with attached Garage	2007		
New		Two-story residence with attached garage	2007		
New		Two story home w/ attached Garage	2007		
New		Two Story SFR with attached Garage	2007		
New		2007 60 X 40 Triplewide Manufactured home	2007		
New		46 ft x 70 ft SFR with attached garage	2007		
New	Approved Basic 06-130320BP	2003 IRC	2 story SFR w/attached 2 car garage	Plan:C	2007
New		2007 23 ft 4 In X 44 ft	Double-wide MH		2007
New		2006 Marlette Mobile Home			2007
New		New SFR - 2 story split level with attached garage			2007
New		MICROFILMED TO TA# & VERIFIED 3/1/2012 kjarnett.	1987 66 X 28	Double Wide MH	2007
New	Approved Basic 07-103268-BP	2003 IRC	Plan # 06.12.113	2-Story SFR w/ attached g	2007
New		2-Story single family residence w/ attached garage.			2007
New	Approved Basic 07-102961-BP	2003 IRC	Plan: 07.01.108	2-story SFR w/attached gar	2007
New		2-story w/garage			2007
New		Two-story sfr w/finished basement			2007
New		Rambler			2007
New		Split level home w/ unfinished lower floor & attached 2 car garage			2007
New		54 ft x 76 ft two story SFR with semi-finished basement and attached garage			2007
New		2-story SFR w/garage			2007
New		Two story SFR with Semi-Finished Lower Level & attached Garage			2007
New		Two story SFR with attached Garage			2007
New	SENT PERMIT FOLDER TO RECORDS ROOM 12/01/08 DM	Two-story residence with attached ga			2007
New	SENT PERMIT FOLDER TO RECORDS ROOM 11/26/08 DM	Two Story SFR w/ unfinished basemer			2007
New		SFR with 1136 SF Basement (unfinished) and Attached Garage			2007

Accessory Dwelling Units

Index # - File Name: 1.0022 - Single Family Dwellings Data\_Snohomish County.pdf

New	SFR with 1136 SF Unfinished Basement and Attached Garage	2007
New	2-story sfr finished basement w/attached garage	2007
New	Rambler style w/unfinished basement & garage	2007
New	Two story Duplex with attached Garage.	2007
New	Two story SFR w/ attached garage	2007
New	Rambler style sfr w/attached garage	2007
New	2-story single family residence.	2007
New	1548 sf rambler style SFR	2007
New	EXPIRED WITHOUT COUNTY APPROVAL TO USE OR OCCUPY 3/17/09 DM Supercede expired co	2007
New	2-story SFR w/ semi-finished basement and garage	2007
New	SENT PERMIT FOLDER TO RECORDS ROOM 11/26/08 DM Two-story residence with attached ga	2007
New	Approved Basic No. 07- 108319 Builder s Plan No. 2267 One Story w/ attached 3 car ga	2007
New	Triple wide MH	2007
New	2 story home w/ semi-finished basement & attached 3 car garage	2007
New	Rambler style w/finished basement and garage	2007
New	Two story SFR & finished Basement with attached Garage	2007
New	Approved Basic 06-137095 BP 2003 IRC Split level style SFR w/ 2-car garage Plan: S1715A2I	2007
New	Approved Basic 06-137095 BP 2003 IRC Split level style SFR w/ 2-car garage Plan: S1715A2I	2007
New	Approved Basic 06-137095 BP 2003 IRC Split level style SFR w/ 2-car garage Plan: S1715A2I	2007
New	32 ft x 52 ft two story SFR with attached garage	2007
New	2 story SFR home w/ finished basement & attached garage	2007
New	Two-story Duplex with garage	2007
New	Rambler with attached garage	2007
New	SFR, single story w/ attached 3 car garage	2007
New	22 ft x 40 ft SFR with attached garage	2007
New	SENT PERMIT FOLDER TO RECORDS ROOM 11/21/08 DM Two-story SFR - 2003 IRC	2007
New	Duplex, 2 story with attached garage	2007
New	Rambler style w/finished basement and garage	2007
New	2-story Duplex w/garage & finished basement	2007
New	2007 CMH 01-522F (27x52) Mobile Home, used as a Temporary Dwelling for family in need of r	2007
New	3080 sq ft Duplex with attached Garage	2007
New	SENT PERMIT FOLDER TO RECORDS ROOM 11/24/08 DM 2-Story SFR w/attached garage.	2007
New	Two story SFR with Unfinished Basement	2007
New	SENT PERMIT FOLDER TO RECORDS ROOM 10/15/08 DM 1988 Double Wide Mobile Home	2007
New	2007 Kit Mgt	2007
New	Approved Basic 05-116604 BP 2003 IRC Plan: 2089	2007
New	SENT PERMIT FOLDER TO RECORDS ROOM 10/23/08 DM 1985 28 X 60 Double-Wide MH	2007
New	SENT PERMIT FOLDER TO RECORDS ROOM 10/22/08 DM 2,442 sf Rambler with attached garag	2007
New	Rambler style w/garage and covered porch	2007
New	New 2163 sq. ft rambler sfr w/ attached garage	2007
New	672 sq ft Guesthouse with attached two story Garage	2007
New	2135 sq ft single family residence with 704 sq ft attached garage.	2007
New	SENT PERMIT FOLDER TO RECORDS ROOM 10/28/08 DM 840 sq ft detached assessorly apartme	2007
New	Two-story residence with attached garage	2007
New	SENT PERMIT FOLDER TO RECORDS ROOM 12/01/08 DM CASP AF# 200709190621 2 story SFR	2007
New	2007 Fleetwood Mobile Home	2007
New	Two-story residence with attached garage	2007



Accessory Dwelling Units

Index # - File Name: 1.0022 - Single Family Dwellings Data\_Snohomish County.pdf

New	Two story SFR with attached Garage	2007
New	new two story SFR (detached garage)	2007
New	Rambler style SFR w/attached garage.	2007
New	Two story SFR with attached Garage	2007
New	Two story SFR with attached Garage	2007
New	Two story SFR with attached Garage	2007
New	2279 sq ft single family residence with attached 419 sq ft garage.	2007
New	Two-story SFR with unfinished basement and attached garage - 2003 IRC	2007
New	Two Story SFR with attached Garage	2007
New	RAMBLER STYLE SFR WITH 1443 SF ATTACHED GARAGE - 2003 IRC	2007
New	Two-story residence with attached garage	2007
New	Mobile home 2006 Triple wide	2007
New	Two-story SFR with attached garage	2007
New	Rambler with Attached Garage	2007
New	SENT PERMIT FOLDER TO RECORDS ROOM 11/21/08 DM Two story SFR with attached Garage	2007
New	Two story SFR with Semi-Finished Basement & attached Garage	2007
New	Approved Basic 05-100241BP 2003 IRC Plan: 1561 2 story Duplex w/attached ga	2007
New	Approved basic 07-109086 BP 2006 IRC Plan: 1561	2007
New	Approved Basic 05-100241BP 2003 IRC Plan: 1561 2 story Duplex w/attached ga	2007
New	SENT PERMIT FOLDER TO RECORDS ROOM 12/01/08 DM 1950 sq ft 2-story single family residen	2007
New	Finish work on expired permit: 04-113479-RK - rambler SFR w/ attached garage	2007
New	2-story SFR w/garage	2007
New	Approved Basic 05-100241BP 2003 IRC Plan: 1561 2 story Duplex w/attached ga	2007
New	2-story SFR w/garage	2007
New	Two-story residence with attached garage	2007
New	Rambler style SFR with finished daylight basement - 2003 IRC	2007
New	Rambler style SFR with finished daylight basement - 2003 IRC	2007
New	61 x 40 two story SFR with unfinished basement & attached garage	2007
New	2 story single family with 3 car garage	2007
New	2006 27 ft X 60 ft Double-wide MH	2007
New	New SFR one story with attached garage and bonus room over garage Replacing existing	2007
New	Two story SFR & Semi-Finished Basement with attached Garage	2007
New	Rambler style, 3 bedroom home with attached 2 car garage	2007
New	817 sf Accessory Apartment w/1232 sf garage and 415 sf 2nd floor storage	2007
New	Rambler with attached garage	2007
New	SENT PERMIT FOLDER TO RECORDS ROOM 12/01/08 DM Two-story residence with attached ga	2007
New	40 ft x 56 ft Triple wide with 14 ft x 22 ft Pod.	2007
New	2-Story SFR w/attached garage.	2007
New	SENT PERMIT FOLDER TO RECORDS ROOM 11/24/08 DM Rambler with daylight basement with	2007
New	2 story single family residence with garage	2007
New	Two story SFR	2007
New	1196 sq ft Rambler	2007
New	Two-story SFR with attached garage - 2003 IRC	2007
New	To complete final on 02-105983 RK	2007
New	New residence with garage in lower level and livable space in lower and upper level	2007
New	3133 sq ft single family residence	2007
New	Detached Accessory Apartment	2007

Accessory Dwelling Units

Index # - File Name: 1.0022 - Single Family Dwellings Data\_Snohomish County.pdf

New	SENT PERMIT FOLDER TO RECORDS ROOM 12/01/08 DM	Single Story SFR with Attached Garage	2007
New	SENT PERMIT FOLDER TO RECORDS ROOM 10/15/08 DM	2 story sfr w/attached garage	2007
New	27 x 60 2007 Karsten KMCK-60862		2007
New	2-story sfr w/garage		2007
New	Conversion permit - converting existing SFR to detached Accessory Apartment (816 sqft main flc		2007
New	Two story SFR with attached Garage		2007
New	SENT PERMIT FOLDER TO RECORDS ROOM 10/15/08 DM	double wide mobile home to be used	2007
New	SENT PERMIT FOLDER TO RECORDS ROOM 11/26/08 DM	As of 12/20/07 Allan and Sherry McVa	2007
New	2-Story SFR w/attached garage replacing existing mobile home to be removed.		2007
New	2-story w/garage		2007
New	Approved Basic 07-102961-BP	2003 IRC Plan: 07.01.108 2-story SFR w/attached gar	2007
New	Split Entry style SFR w/basement garage.		2007
New	2- Story SFR w/attached garage		2007
New	28 x 48 double wide manufactured home		2007
New	SENT PERMIT FOLDER TO RECORDS ROOM 12/01/08 DM	Two story SFR w/ attached garage	2007
New	SENT PERMIT FOLDER TO RECORDS ROOM 10/15/08 DM	2-Story SFR w/attached garage.	2007
New	28x66, 1996 Palm Harbor		2007
New	44 ft x 60 ft Two Story SFR with attached garage		2007
New	Single story single family residence with no garage - 2003 IRC		2007
New	2-story duplex		2007
New	Approved Basic 07-102961-BP	2003 IRC Plan: 07.01.108 2-story SFR w/attached gar	2007
New	Approved Basic 07-102961 BP	2003 IRC Plan: 07.01.108 2-story SFR w/attached gar	2007
New	Approved basic 05-101044 BP	2003 IRC Plan 1361-2 DLB (2 car)	2007
New	New two story SFR w/ attached garage		2007
New	Two Story SFR w/ attached garage ( existing mobile to be removed)(MH removed. Abooth 2/9/c		2007
New	2 story SFR with attached 3 car garage		2007
New	Two-story SFR with attached garage - 2003 IRC(MH removed. Abooth 2/9/09)		2007
New	Rambler with attached garage		2007
New	2-story SFR w/garage		2007
New	SENT PERMIT FOLDER TO RECORDS ROOM 10/22/08 DM	Two-story SFR with finished basement	2007
New	SENT PERMIT FOLDER TO RECORDS ROOM 11/24/08 DM	Rambler style sfr w/attached garage	2007
New	Rambler style sfr w/attached garage		2007
New	Two Story SFR with Attached Garage		2007
New	Two story SFR with attached Garage		2007
New	New SFR w/ attached garage		2007
New	SENT PERMIT FOLDER TO RECORDS ROOM 11/26/08 DM	Two Story SFR with Attached Garage	2007
New	2-story single family residence w/ attached garage.	2003 IRC	2007
New	Rambler w/ unfinished basement & attached 3 car garage		2007
New	Two Story SFR with Attached Garage		2007
New	SENT PERMIT FOLDER TO RECORDS ROOM 10/15/08 DM	1020 sf Garage with residential dwelli	2007
New	SENT PERMIT FOLDER TO RECORDS ROOM 10/23/08 DM	Two-story residence with attached ga	2007
New	Two story SFR with Finished Basement & attached Garage		2007
New	1563 sq ft Rambler with attached Garage		2007
New	Two story SFR with attached Garage		2007
New	Rambler style SFR with attached single car garage.		2007
New	2 story SFR with attached garage		2007
New	New 1 story 848 sq. ft. new SFR (future guest cottage) with 10 x 10 unheated crawl space for u		2007

Accessory Dwelling Units

Index # - File Name: 1.0022 - Single Family Dwellings Data\_Snohomish County.pdf

New	2-story SFR w/garage and unfinished basement	2007
New	New two story SFR (w/ detached garage) replacing existing SFR w/ new	2007
New	two story SFR w/ finished basement and attached garage	2007
New	2-story sfr w/attached garage	2007
New	Two story single family residence.	2007
New	2067 sq ft single family residence with 543 sq ft attached garage.	2007
New	27 ft x 56 ft double wide MH	2007
New	SENT PERMIT FOLDER TO RECORDS ROOM 11/21/08 DM Two story SFR with attached Garage	2007
New	SENT PERMIT FOLDER TO RECORDS ROOM 10/15/08 DM 550 sqft Detchd Accessory Apt, w/ 47	2007
New	SENT PERMIT FOLDER TO RECORDS ROOM 12/01/08 DM Two story SFR with attached Garage	2007
New	Rambler with attached Garage	2007
New	Rambler style Duplex w/attached garages.	2007
New	Building permit for Detached Accessory Apartment	2007
New	SENT PERMIT FOLDER TO RECORDS ROOM 11/24/08 DM Two-story residence with attached ga	2007
New	RSP to SHD 4/11/07 TLilly(Exisiting 1940 s house removed) 2 story home with attached 3 car ga	2007
New	2363 sq ft Rambler with attached Garage	2007
New	Replacing mobile home with Two Story SFR w/ attached garage	2007
New	SENT PERMIT FOLDER TO RECORDS ROOM 12/01/08 DM new 2 story SFR w/ attached garage	2007
New	Rambler with attached garage	2007
New	2,800 sq ft SFR with 500 sq ft attached garage	2007
New	Two-story residence	2007
New	28 ft x 32 ft two story sfr with unfinished basement	2007
New	SENT PERMIT FOLDER TO RECORDS ROOM 11/24/08 DM 861sq ft Garage with 837 sq ft 2nd flo	2007
New	2-Story SFR w/attached garage	2007
New	SENT PERMIT FOLDER TO RECORDS ROOM 11/21/08 DM 51 ft x 86 ft SFR with attached garage	2007
New	Proposed detached garage and accessory apartment.	2007
New	new two stor SFR w/ attached garage	2007
New	Detached Accessory Apartment 22 x 26= 572 sqft	2007
New	Two story SFR with Attached Garage	2007
New	New detached accessory apartment and two car garage	2007
New	2-story SFR w/garage	2007
New	Approved basic 06-129078 BP 2003 IRC Plan# 2838 2 story with attached 3 car garağ	2007
New	3037 sq ft single family residence with 940 sq ft attached garage.	2007
New	Rambler style SFR w/garage	2007
New	2 story Duplex with attached garage	2007
New	SENT PERMIT FOLDER TO RECORDS ROOM 10/27/08 DM 61 ft x 70 ft two story SFR with basem	2007
New	2-Story SFR w/attached garage.	2007
New	SENT PERMIT FOLDER TO RECORDS ROOM 11/26/08 DM 2-Story SFR w/attached garage.	2007
New	Approved Basic 06-101863 BP 2003 IRC Plan: 1361-2 Two-story SFR with attach	2007
New	SENT PERMIT FOLDER TO RECORDS ROOM 11/24/08 DM New 2 story SFR w/ semi finished 2nd	2007
New	residence with garage on lower level	2007
New	SENT PERMIT FOLDER TO RECORDS ROOM 10/27/08 DM Two-story SFR with attached garage -	2007
New	Two story SFR w/ attached garage unfinished basement and unfinished attic	2007
New	Rambler with attached garage	2007
New	Patio cover 12 x 20	2007
New	Two story SFR with unfinished Basement & attached Garage	2007
New	Two story SFR with unfinished Basement & attached Garage	2007

Accessory Dwelling Units

Index # - File Name: 1.0022 - Single Family Dwellings Data\_Snohomish County.pdf

New	SENT PERMIT FOLDER TO RECORDS ROOM 11/26/08 DM	2-story SFR w/garage	2007
New		2-Story SFR w/attached garage.	2007
New	SENT PERMIT FOLDER TO RECORDS ROOM 10/15/08 DM	450sf cob house with 168sf loft	2007
New		2272 sq ft Rambler with attached Garage	2007
New		Rambler with attached 3 car garage	2007
New		Two-story residence with attached garage	2007
New		14x66 2007 Fleetwood Broadmore	2007
New		1746 sf rambler with attached garage - 2003 IRC	2007
New	SENT PERMIT FOLDER TO RECORDS ROOM 11/24/08 DM	2-story w/finished basement and gara	2007
New	CASP # 200707240899	27 x 71 2002 Palm Harbor Mobile Home	2007
New		two story sfr w/ semi-finished upstairs bonus and attached garage	2007
New		Change two story SFR to one story SFR with attached Garage	2007
New		Rambler style w/garage	2007
New		2 story SFR w/ attached garage and unfinished basement	2007
New		1218 sq ft SFR with Semi-Finished Basement	2007
New		1960 sq ft Rambler with attached Garage	2007
New		2-story sfr w/attached garage	2007
New		Two story SFR with attached Garage	2007
New		2006 27 x 52 double wide Mobile Home	2007
New		2-story SFR w/garage	2007
New	Approved Basic 04-116655BP	Plan:1864 Rambler with Attached Garage	2003 IRC 2007
New		Rambler style w/garage and covered deck/entry	2007
New	Approved Basic 04-116655BP	Plan:1864 Rambler with Attached Gara	2007
New	SENT PERMIT FOLDER TO RECORDS ROOM 12/01/08 DM	720 sq ft detached accessory apartme	2007
New		56 ft x 59 ft two story SFR with attached 3 car garage	2007
New		2-story SFR w/garage CASP AF#200704260287	2007
New	Permit transfered to Birdsong Construction 05-26-2009 jr lind	SENT PERMIT FOLDER TO RECC	2007
New		850 sq ft detached accessory apartment.	2007
New	Approved Basic # 07-100824BP	2003 IRC Plan: 3216 Two story SFR with attached Ga	2007
New		Rambler with daylight basement and garage	2007
New	SENT PERMIT FOLDER TO RECORDS ROOM 10/27/08 DM	Two story SFR with attached garage	2007
New	Approved Basic 06-103360BP	2003 IRC 2 story SFR w/attached garage Plan:3840C	2007
New	Approved Basic 06-103358BP	2003 IRC 2 story SFR w/attached garage Plan:3840A	2007
New	Approved Basic 04-121596BP	2 Story SFR w/attached garage 2003 IRC Plan:4044ABC	2007
New	Approved basic 05-121434 BP	2003 IRC Plan# 3052A 2-story sfr w/attached garage	2007
New	Approved Basic 06-102439BP	2003 IRC 2 story SFR w/attached garage Plan:4044A	2007
New	SENT PERMIT FOLDER TO RECORDS ROOM 10/28/08 DM	Approved basic 06-130542 BP 2	2007
New	Approved Basic 06-102439BP	2003 IRC 2 story SFR w/attached garage Plan:4044A	2007
New	Approved Basic 06-103360BP	2003 IRC 2 story SFR w/attached garage Plan:3840C	2007
New	SENT PERMIT FOLDER TO RECORDS ROOM 10/28/08 DM	Approved Basic 06-103360BP 2003 I	2007
New	Approved Basic 06-101023BP	2003 IRC 2 story SFR w/attached garage P Lan:7032AB	2007
New	Approved basic 05-121435 BP	2003 IRC Plan# 3052B 2-story sfr w/attached garage	2007
New	Approved Basic 06-102439BP	2003 IRC 2 story SFR w/attached garage Plan:4044A	2007
New	Approved Basic 06-102439BP	2003 IRC 2 story SFR w/attached garage Plan:4044A	2007
New	Approved basic 05-121434 BP	2003 IRC Plan# 3052A 2-story sfr w/attached garage	2007
New	Approved Basic 04-121305BP	2 story SFR w/attached garage 2003 IRC Plan:3060AB	2007
New	Approved basic 05-127356 BP	2003 IRC Plan# 2306 A&B 2-story sfr w/attache	2007

Accessory Dwelling Units

Index # - File Name: 1.0022 - Single Family Dwellings Data\_Snohomish County.pdf

New	SENT PERMIT FOLDER TO RECORDS ROOM 12/01/08 DM	Rambler with attached garage	2007
New	Approved Basic 06-101023BP	2003 IRC 2 story SFR w/attached garage	2007
New		2-Story SFR w/attached garage.	2007
New		Two-story residence with attached garage	2007
New	Approved Basic 04-111511BP	Plan 3387-B Two-story SFR - 2003 IRC	2007
New	Approved Basic 04-114264BP	Plan: 3192A Two-story SFR - 2003 IRC	2007
New	Approved Basic 04-112274BP	2 story SFR w/ attached garage 2003 IRC	2007
New	Approved Basic 05-100687BP	2003 IRC Plan: 2112 A&B	2007
New	Approved Basic 04-116177BP	Builders plan# 2575-A&B 2-Story SFR w/atta	2007
New	Approved Basic 04-112274BP	2 story SFR w/ attached garage 2003 IRC	2007
New	Approved Basic 04-111504BP	Plan: 2863-B Two-story SFR - 2003 IRC	2007
New	Approved Basic 04-116427BP	Plan: 3512 A & B Two-story SFR with attach	2007
New	Approved Basic 04-111506BP	Plan: 2863-C Two-story SFR - 2003 IRC	2007
New	Approved Basic 05-100213BP	2003 IRC Plan: 2640 A & B	2007
New	Approved basic 05-127356 BP	2003 IRC Plan# 2306 A&B	2007
New	Approved Basic 04-114926BP	2 story SFR w/attached garage 2003 IRC	2007
New	Approved Basic 04-114926BP	2 story SFR w/attached garage 2003 IRC	2007
New		Two story SFR with finished Basement & attached Garage	2007
New	Approved Basic 05-118728BP	2003 IRC 2 story SFR w/attached garage	2007
New	Approved Basic 05-118736BP	2003 IRC 2 story SFR w/attached garage	2007
New	Approved Basic 05-118728BP	2003 IRC 2 story SFR w/attached garage	2007
New		New SFR	2007
New		Two-story sfr with garage	2007
New	SENT PERMIT FOLDER TO RECORDS ROOM 12/01/08 DM	new two story SFR w/ attached garage	2007
New		2-story sft w/attached garage	2007
New		2-story sfr w/attached garage	2007
New	Approved Basic 04-111504BP	Plan: 2863-B Two-story SFR - 2003 IRC	2007
New	Approved Basic 05-100213BP	2003 IRC Plan: 2640 A & B	2007
New		Rambler with daylight basement	2007
New		Single story rambler style SFR with attached garage	2007
New	SENT PERMIT FOLDER TO RECORDS ROOM 12/01/08 DM	Two Story SFR with Finished Basemen	2007
New	SENT PERMIT FOLDER TO RECORDS ROOM 11/24/08 DM	Two-story SFR with unfinished basem	2007
New		796 sq ft Guesthouse with attached Garage	2007
New	SENT PERMIT FOLDER TO RECORDS ROOM 11/26/08 DM	Approved basic 05-127356 BP	2007
New	SENT PERMIT FOLDER TO RECORDS ROOM 11/26/08 DM	Approved Basic 05-100213BP	2007
New		Two Story SFR - 2003 IRC	2007
New		2 story SFR w/ attached garage garage	2007
New	Approved Basic 05-100936-BP	2003 IRC Plan:1703-Bonus	2007
New		660 sq ft SFR with attached Garage	2007
New	SENT PERMIT FOLDER TO RECORDS ROOM 11/26/08 DM	Rambler with attached garage	2007
New	SENT PERMIT FOLDER TO RECORDS ROOM 10/15/08 DM	1045 sq ft SFR with 980 sq ft Unfinishe	2007
New		2 story home with attached 2 car garage (4 bedrooms plus bonus room)	2007
New		4483 sq ft single family residence with attached garage.	2007
New		Two story SFR with attached Garage	2007
New	SENT PERMIT FOLDER TO RECORDS ROOM 12/01/08 DM	Two story SFR with attached Garage	2007
New	Approved Basic 04-117192BP	2003 IRC Plan 2225 - 3 Car Ram	2007
New		2904sf SFR with 1336sf finished daylight basement and 644sf unfinished basement	2007

Accessory Dwelling Units

Index # - File Name: 1.0022 - Single Family Dwellings Data\_Snohomish County.pdf

New	Approved Basic 06-135398 BP	2003 IRC	Plan: 2338	2-story residence with garag	2007
New	Approved basic 05-1296374 BP	2003 IRC	Plan # 2394	2-story sfr w/attached garage	2007
New	Approved Basic 06-135398 BP	2003 IRC	Plan: 2338	2-story residence with garag	2007
New	Approved basic 05-1296374 BP	2003 IRC	Plan # 2394	2-story sfr w/attached garage	2007
New	Approved basic 05-126370 BP	2003 IRC	Plan # 226-1007	2-story sfr w/attached gara	2007
New	Approved basic 05-126370 BP	2003 IRC	Plan # 226-1007	2-story sfr w/attached gara	2007
New	Approved basic 05-126368 BP	2003 IRC	Plan # 226-1002	2-story sfr w/attached gara	2007
New	Approved basic 05-1296374 BP	2003 IRC	Plan # 2394	2-story sfr w/attached garage	2007
New	Approved Basic 06-135398 BP	2003 IRC	Plan: 2338	2-story residence with ga	2007
New	2-Story SFR over semi-finished daylight basement w/attached garage.				2007
New	Approved Basic 06-135398 BP	2003 IRC	Plan: 2338	2-story residence with garag	2007
New	Approved basic 05-1296374 BP	2003 IRC	Plan # 2394	2-story sfr w/attached garage	2007
New	Approved basic 05-126368 BP	2003 IRC	Plan # 226-1002	2-story sfr w/attached gara	2007
New	Approved basic 05-126373 BP	2003 IRC	Plan # 226-1001	2-story sfr w/attached gara	2007
New	Approved basic 05-126368 BP	2003 IRC	Plan # 226-1002	2-story sfr w/attached gara	2007
New	Approved basic 05-126370 BP	2003 IRC	Plan # 226-1007	2-story sfr w/attached gara	2007
New	Approved Basic 06-135398 BP	2003 IRC	Plan: 2338	2-story residence with garag	2007
New	Approved basic 05-126370 BP	2003 IRC	Plan # 226-1007	2-story sfr w/attached gara	2007
New	Approved Basic 06-135398 BP	2003 IRC	Plan: 2338	2-story residence with garag	2007
New	Approved basic 05-126370 BP	2003 IRC	Plan # 226-1007	2-story sfr w/attached gara	2007
New	Approved basic 05-1296374 BP	2003 IRC	Plan # 2394	2-story sfr w/attached garage	2007
New	Approved Basic 06-135398 BP	2003 IRC	Plan: 2338	2-story residence with garag	2007
New	Approved Basic 06-135398 BP	2003 IRC	Plan: 2338	2-story residence with garag	2007
New	Two-story SFR with attached garage - 2003 IRC			The Amherst VIII	2007
New	Approved Basic # 07-100824BP	2003 IRC	Plan: 3216	Two story SFR with attached Ga	2007
New	Two story SFR with attached Garage				2007
New	2-story SFR w/garage				2007
New	Two-story SFR with attached garage - 2003 IRC				2007
New	Reversed Expired Status Sturgeon s sent a copy of the signed off permit dated 7/18/7 by MARKC				2007
New	Approved Basic # 06-126058 BP	2003 IRC	Plan:3082A	Two story SFR with attached C	2007
New	Rambler style, 3 bedroom home with attached 3 car garage				2007
New	New SFR 2 story w/ attachcd garage				2007
New	Two story SFR with attached Garage				2007
New	New Two story SFR w/ attached garage				2007
New	Rambler style SFR w/garage				2007
New	Two story SFR with attached Garage				2007
New	36 ft x 70 ft two storySFR with finished basement and attached 3 car garage				2007
New	2-story SFR w/attached garage.				2007
New	New one story SFR w/ Unfinished basement and attached garage				2007
New	Two-story residence with daylight basement and with attached garage				2007
New	Approved basic 05-126438 BP	2003 IRC	Plan# Unit type B	2-story sfr w/out gar	2007
New	Rambler with daylight basement & attached garage				2007
New	Two-story residence with attached garage				2007
New	Approved Basic 04-114800BP		Plan: 40020-A2	Two-story SFR - 2003 IRC	2007
New	2-story sfr w/attached garage				2007
New	New 2 Story SFR w/ attachcd garage				2007
New	Two-story SFR with attached garage - 2003 IRC				2007

Accessory Dwelling Units

Index # - File Name: 1.0022 - Single Family Dwellings Data\_Snohomish County.pdf

New	2 Story SFR w/ semi basement and attached garage				2007
New	Two-story residence with attached garage				2007
New	58 ft x 66 ft two story SFR with attached garage				2007
New	Two story SFR with attached Garage				2007
New	Approved Basic 04-113768BP	2 story SFR w/attached garage	2003 IRC	Plan:3040	2007
New	Approved Basic 04-119639BP			Plan: Eagle-1 Rambler-style SFR with attach	2007
New	Approved Basic 04-118845BP	2 story SFR w/attached garage	2003 IRC	Plan:2294	2007
New	Approved Basic 06-135057BP	2003 IRC	Two-story SFR with attached garage	Plan: 3070-40-9	2007
New	Approved Basic 06-135057BP	2003 IRC	Two-story SFR with attached garage	Plan: 3070-40-9	2007
New	Approved Basic 04-120030BP			Plan :The Chandler 1 Story SFR w/semifinished basement	2007
New	Approved Basic 06-135064BP	2003 IRC	Two-story SFR with attached garage	Plan: 3189-39	2007
New	Approved Basic 06-135064BP	2003 IRC	Two-story SFR with attached garage	Plan: 3189-39	2007
New	Approved Basic 06-135057BP	2003 IRC	Two-story SFR with attached garage	Plan: 3070-40-9	2007
New	Approved Basic 06-127259BP	2003IRC	Two-story SFR with attached garage	Plan: 21	2007
New	Approved Basic 06-127259BP	2003IRC	Two-story SFR with attached garage	Plan: 21	2007
New	Approved Basic 06-127259BP	2003IRC	Two-story SFR with attached garage	Plan: 21	2007
New	Approved Basic #06-129185 BP	2003 IRC	Plan: 2095	2- story SFR w/attached	2007
New	Approved Basic 04-116493BP			Plan: 2421 C Two-story SFR with attached	2007
New	Approved Basic 06-102459 BP	2003 IRC	2-story w/garage	Plan:2680	2007
New	Approved Basic 05-122829BP	2003 IRC	2 story SFR w/attached garage	Plan:1809	2007
New	Approved Basic 06-127259BP	2003IRC	Two-story SFR with attached garage	Plan: 21	2007
New	Approved Basic 06-103500BP	2003 IRC	2 story SFR w/attached garage	Plan:3439	2007
New	Approved Basic 05-118211BP	2003 IRC	2 story SFR w/attached garage	Plan:3114-A	2007
New	Approved Basic 07-109650-BP	Builder No. 2621 C	2006 IRC / WSEC	2 story SFR with a	2007
New	Two story SFR with Basement & attached Garage				2007
New	Approved basic 06-130641 RK	2003 IRC	Plan# 3027 (E)	2-story sfr w/attache	2007
New	Approved Basic 06-103500BP	2003 IRC	2 story SFR w/attached garage	Plan:3439	2007
New	Approved Basic 06-132951BP	2003 IRC	Two-Story SFR with attached garage	Plan: 3511C	2007
New	Approved Basic 05-116050BP		20003 IRC	Plan:2031C	2007
New	Approved Basic 07-101227-BP	2003 IRC	Two-story SFR with attached garage	Plan 1521A	2007
New	Approved Basic 04-119795BP	2 story SFR w/attached garage	2003 IRC	Plan:1821C	2007
New	Approved Basic 07-110119-BP	2006 IRC	Plan # 2421 A	2-Story SFR w/ attached	2007
New	Approved Basic 06-133265BP -	2003 IRC	Two-story SFR with attached garage	Plan: 2411 A	2007
New	Approved Basic 06-132292BP	2003 IRC	Two-story SFR with attached garage	Plan: 3541A	2007
New	Approved Basic 07-109650-BP	Builder No. 2621 C	2006 IRC / WSEC	2 story SFR with a	2007
New	Approved 07-109130-BP	2006 IRC	Plan # 2011 A	2-Story SFR w/ attached garag	2007
New	Approved Basic 04-117263BP	2 story SFR w/attached garage	2003 IRC	Plan:3131B	2007
New	Approved Basic 07-113568-BP	Plan No 2441 B	2006 IRC	2 story SFR w/ 2 or 3 car optio	2007
New	Approved Basic 06-133260BP -	2003 IRC	Two-story SFR with attached garage	Plan: 2075 B	2007
New	Approved Basic 05-118338 BP	2003 IRC	Plan:1909BSM		2007
New	Approved Basic 07-109130-BP	2006 IRC	Plan # 2011 A	2-Story SFR w/ attached	2007
New	Approved Basic 07-109650-BP	Builder No. 2621 C	2006 IRC / WSEC	2 story SFR with a	2007
New	Approved Basic 07-112525-BP	2006 IRC	Plan # 2265 C	2-Story SFR w/attached	2007
New	Approved Basic 07-112526-BP	2006 IRC	Plan # 2295 B	2- Story SFR w/ attached	2007
New	Approved Basic 06-132658BP	2003 IRC	Two-story SFR with attached garage	Plan: 2211A	2007
New	Approved Basic 06-133263BP -	2003 IRC	Two-story SFR with attached garage	Plan: 2055 B	2007
New	Approved Basic 07-110118-BP	2006 IRC	Plan # 3111 C	2-Story SFR w/ attached	2007

Accessory Dwelling Units

Index # - File Name: 1.0022 - Single Family Dwellings Data\_Snohomish County.pdf

New	Approved Basic 04-120167BP	2 story SFR w/attached garage	2003 IRC	Plan:2597	2007
New	Approved basic 06-126631 BP	2003 IRC	Plan# 2278 Alt	2-story sfr w/attached gar	2007
New	Approved basic # 07-108468 BP	2006 IRC	Plan # 2747	2 story SFR w/ attached 2 car gar	2007
New	Approved basic # 07-108468 BP	2006 IRC	Plan # 2747	2 story SFR w/ attached 2 car gar	2007
New	Approved Basic 05-127365BP	2003 IRC	2 story SFR w/attached garage	Plan:3131A & l	2007
New	Approved Basic 05-100756BP		2003 IRC	Plan:2295B	2007
New	Approved Basic 05-121678BP	2003 IRC	2 story SFR w/attached garage	Plan:241	2007
New	Approved Basic 07-103802-BP	2003 IRC	Plan # 2265B	2-Story SFR w/ attached {	2007
New	Approved Basic 04-116503BP		Plan: 1811B	Two-story SFR with attached {	2007
New	Approved Basic 05-125684BP	2003 IRC	2 story SFR w/attached garage	Plan:3027A	2007
New	Approved Basic 04-120107BP	2 story SFR w/attached garage	2003 IRC	Plan:3121C	2007
New	Approved Basic 04-117263BP	2 story SFR w/attached garage	2003 IRC	Plan:3131B	2007
New	Approved Basic 05-122161 BP	2003 IRC	Plan# 3131C	2 - story sfr w/attached ga	2007
New	Approved Basic 05-117923BP	2003 IRC	Plan:2585A	2 story SFR w/attached gara	2007
New	Approved basic 07-107576 BP	2006 IRC	Plan# 2255 C	2-story sfr w/attached ga	2007
New	Approved Basic 04-116513BP	Plan: 2421 A & B	Two-story SFR with attached two-car garage		2007
New	Approved Basic 05-117923BP	2003 IRC	Plan:2585A	2 story SFR w/attached gara	2007
New	Approved Basic 07-109362-BP	Builder No. 2295 A	2006 IRC / WSEC	2 story SFR with ;	2007
New	Approved Basic 04-116517BP		Plan: 2221 B	Two-story SFR with attached gara	2007
New	Approved Basic 04-116503BP		Plan: 1811B	Two-story SFR with attached garage -	2007
New	Approved Basic 05-117923BP	2003 IRC	Plan:2585A	2 story SFR w/attached gara	2007
New	Approved Basic 04-120167BP	2 story SFR w/attached garage	2003 IRC	Plan:2597	2007
New	Approved Basic 05-128525 BP	2003 IRC	2 story SFR w/attached garage	Plan:245	2007
New	Approved Basic # 07-101197 BP	2003 IRC	Plan 2747	Two story SFR with attached Gar	2007
New	Approved Basic # 07-101197 BP	2003 IRC	Plan 2747	Two story SFR with attached Gar	2007
New	Approved Basic # 07-101197 BP	2003 IRC	Plan 2747	Two story SFR with attached Gar	2007
New	SENT PERMIT FOLDER TO RECORDS ROOM 11/26/08 DM Approved Basic 05-128525 BP				2
New	Approved Basic # 07-101197 BP	2003 IRC	Plan 2747	Two story SFR with attached Gar	2007
New	Approved Basic 05-124338 BP	2003 IRC	Plan # 2454	Rambler w/ attached Garage	2007
New	Approved Basic 05-124338 BP	2003 IRC	Plan # 2454	Rambler w/ attached Garage	2007
New	Approved Basic 05-124338 BP	2003 IRC	Plan # 2454	Rambler w/ attached Garage	2007
New	88 ft x 92 ft SFR with attached garage				2007
New	Approved Basic 06-127032BP	2003 IRC	2 story SFR w/attached garage	Plan:2323 Revised	2007
New	Approved Basic 05-124338 BP	2003 IRC	Plan # 2454	Rambler w/ attached Garage	2007
New	2-story SFR w/attached garage. NSF CHECK. Accept only cash, cc or cashier s check.				2007
New	Approved Basic 06-102242BP	Rambler style SFR with 3-car garage -	2003 IRC	Plan: Wisteri	2007
New	Approved Basic 06-125770BP	Two-story SFR with 3-car garage	2003 IRC	Plan: Cascade #1	2007
New	Approved Basic 06-101849BP		2003 IRC	Plan: Dahlia 2553 Ra	2007
New	52 ft x 80 ft 2 story SFR with attached garage				2007
New	Approved Basic 06-125770BP	Two-story SFR with 3-car garage	2003 IRC	Plan: Cascade #1	2007
New	Approved Basic #05-118418 BP	2003 IRC	Plan #2452	Two story SFR w/ Attached G	2007
New	Approved Basic 05-120701BP	2003 IRC	2 story SFR w/attached garage	Plan: 25!	2007
New	Approved Basic 05-120701BP	2003 IRC	2 story SFR w/attached garage	Plan: 25!	2007
New	Approved Basic #05-118418 BP	2003 IRC	Plan #2452	Two story SFR w/ Attached G	2007
New	Approved Basic 06-126476BP	Two-story SFR with 3-car garage	2003 IRC	Plan: 2777	2007
New	Approved Basic 06-126470BP	Two-story SFR with 3-car garage	2003IRC	Plan: 2958	2007
New	Approved Basic 06-126476BP	Two-story SFR with 3-car garage	2003 IRC	Plan: 2777	2007



Accessory Dwelling Units

Index # - File Name: 1.0022 - Single Family Dwellings Data\_Snohomish County.pdf

New	Approved Basic 06-126951BP	2003 IRC	Two-story SFR with 3-car garage	Plan: 2687	2007
New	Approved Basic 06-126951BP	2003 IRC	Two-story SFR with 3-car garage	Plan: 2687	2007
New	Approved Basic 05-120701BP	2003 IRC	2 story SFR w/attached garage	Plan: 259	2007
New	Approved Basic 05-120713BP	2003 IRC	2 story SFR w/attached garage	Plan:2224F	2007
New	Approved Basic #05-118418 BP	2003 IRC	Plan #2452 Two story SFR w/ Attached G		2007
New	Two-story SFR with attached garage -	2003 IRC	Plan: 2960/ Beaumont		2007
New	Approved basic 06-125342 BP	2003 IRC	Plan# 1319 A 2-story sfr w/attached		2007
New	Approved Basic # 06-133200 BP	2003 IRC	Plan: 2396 DD 2-story SFR w/attached gar		2007
New	Approved Basic 06-128699BP	2003 IRC	Two-story SFR with attached garage	Plan: 2465	2007
New	Approved basic 06-101007 BP	2003 IRC	Plan# 2212 2-story sfr w/attached garag		2007
New	Approved basic 06-131285 BP	2003 IRC	Plan# 2396 (2) 2-story sfr w/attached gara		2007
New	Approved Basic 06-128686BP	2003IRC	Two-story SFR with attached garage	Plan: 2	2007
New	Approved basic 06-127957 BP	2003 IRC	Plan# 2381 2-story sfr w/attached garage		2007
New	Approved basic 06-101007 BP	2003 IRC	Plan# 2212 2-story sfr w/attached garag		2007
New	Approved Basic # 06-133200 BP	2003 IRC	Plan: 2396 DD 2-story SFR w/attached gar		2007
New	Approved Basic 06 126575 BP	2003 IRC	Builders Plan: 2052 Two-story SFR		2007
New	Approved basic 06-127957 BP	2003 IRC	Plan# 2381 2-story sfr w/attached garage		2007
New	Approved Basic: 07-110125-BP	Plan No. 1017 B	2006 IBC/IRC 2 story SFR w/ attached 1 ca		2007
New	Approved Basic 07-104232 BP	2003 IRC	Plan: 1600G Two-story SFR with attached ga		2007
New	Approved Basic 06-134812BP	2003 IRC	Plan # 2554G 2-Story SFR w/basement & atta		2007
New	Approved Basic 07-104232 BP	2003 IRC	Plan: 1600G Two-story SFR with attached ga		2007
New	Approved Basic 07-104225 BP	2003 IRC	Plan: 1600H Two-story sfr with attached gara		2007
New	Approved Basic 07-107238BP	2003 IRC	Plan: 1356H 2-story sfr w/ attached garage		2007
New	Approved Basic 07-104225 BP	2003 IRC	Plan: 1600H Two-story sfr with attached gara		2007
New	Approved Basic 08-100056-BP	2006 IRC	Plan: 1600G 2-story sfr w/ attached garage		2007
New	Approved Basic 04-116621 BP	2 Story SFR w/attached garage	2003 IRC	Plan:1909	2007
New	Approved basic # 07-108469 BP	2006 IRC	Plan # 2188 2 story SFR w/ attached 2 car gar		2007
New	Approved Basic 06-100083BP	2003 IRC	2 story SFR w/attached garage	Plan:21	2007
New	Approved basic 06-129273 BP	2003 IRC	Plan # 1762 2-story sfr w/attached garag		2007
New	Approved basic 06-129274 BP	2003 IRC	Plan# 1854 2-story sfr w/attached garage		2007
New	44 ft x 56 ft one story SFR with attached garage		*issued under tax roll 003944-062-013-00*		2007
New	Two story SFR with Basement & attached Garage				2007
New	Split Level style home w/ unfinished basement & 2 car attchd Garage				2007
New	SENT PERMIT FOLDER TO RECORDS ROOM 12/01/08 DM		Two story SFR with attached Garage		2007
New	Approved Basic 05-126785 BP	Plan: T2734-03A-N	Two-story SFR w/ attached 2 car Gar		2007
New	Approved basic 05-125351 BP	2003 IRC	Plan# 3117 A 2-story sfr w/attached gar		2007
New	Approved basic 05-128452 BP	2003 IRC	Plan# 2440 BE 2-story sfr w/attached gar		2007
New	Approved basic 05-125351 BP	2003 IRC	Plan# 3117 A 2-story sfr w/attached gar		2007
New	Approved Basic 04-120907BP	2 story SFR w/attached garage	2003 IRC	Plan:2140B	2007
New	Approved basic 05-128452 BP	2003 IRC	Plan# 2440 BE 2-story sfr w/attached gar		2007
New	Approved Basic 04-120908BP	2 story SFR w/attached garage	2003 IRC	Plan:2140C	2007
New	Approved basic 05-128452 BP	2003 IRC	Plan# 2440 BE 2-story sfr w/attached gar		2007
New	Approved basic 05-126160 BP	2003 IRC	Plan# 3036 B 2-story sfr w/attached ga		2007
New	Approved basic 05-125349 BP	2003 IRC	Plan# 2440 A 2-story sfr w/attache		2007
New	Approved Basic 04-120908BP	2 story SFR w/attached garage	2003 IRC	Plan:2140C	2007
New	Approved basic 05-126157 BP	2003 IRC	Plan# 2700 B 2-story sfr w/attached g		2007
New	Two story SFR with attached Garage				2007

Accessory Dwelling Units

Index # - File Name: 1.0022 - Single Family Dwellings Data\_Snohomish County.pdf

New	Two story SFR with attached Garage				2007
New	Approved Basic 07-112556-BP	2006 IRC	Plan # 1840	2- Story SFR w/ attached gar	2007
New	Approved Basic 04-116655BP		Plan:1864	Rambler with Attached Gara	2007
New	Approved Basic #04-116770 BP	Plan:2119	2-story w/attached garage	2003 IRC	2007
New	Approved Basic 04-117114BP	Plan: 1538	Rambler with attached garage -	2003 IRC	2007
New	Approved Basic 06-127031BP	2003 IRC	2 story SFR w/finished bsmt	Plan: 2125 bsmt Rev	2007
New	Two Story SFR with finished Basement & attached Garage				2007
New	Two-story SFR over 1723 Finished daylight basement & garage -	2003 IRC	Plan 3040DB		2007
New	Approved Basic 06-101856 BP	2003 IRC	Plan: 2846	Two story SFR with attached Gar	2007
New	Approved Basic 04-115896BP		Builders Plan #2271AC	2 Story w/ 3 Car	2007
New	SENT PERMIT FOLDER TO RECORDS ROOM 11/24/08 DM			Two-story SFR with attached garage	2007
New	Approved Basic #05-126875 BP	2003 IRC	2 story SFR w/attached garage	Pla	2007
New	Approved Basic 05-129393 BP	2003 IRC	2 story SFR w/attached garage	Plan:1.	2007
New	Approved Basic #05-118962 BP	2003 IRC	2 story SFR w/attached garage	Plan:M2625A3	2007
New	Approved Basic #05-126875 BP	2003 IRC	2 story SFR w/attached garage	Plan	2007
New	Approved Basic 04-119744 BP	2 story SFR w/attached garage	2003 IRC	Plan:2214	2007
New	SENT PERMIT FOLDER TO RECORDS ROOM 11/24/08 DM			2-story w/garage	2007
New	Approved Basic 04-115896BP		Builders Plan #2271AC	2 Story w/ 3 Car	2007
New	SENT PERMIT FOLDER TO RECORDS ROOM 11/24/08 DM			Two-story SFR with attached garage 2	2007
New	SENT PERMIT FOLDER TO RECORDS ROOM 11/24/08 DM			Two-story SFR over finished daylight b	2007
New	Approved Basic 04-120908BP	2 story SFR w/attached garage	2003 IRC	Plan:2140C	2007
New	Approved Basic 06-131030 BP	2003 IRC	Plan No. 1440	1-story w/	2007
New	Approved Basic 06-131030 BP	2003 IRC	Plan No. 1440	1-story w/attached	2007
New	Approved Basic 06-131030 BP	2003 IRC	Plan No. 1440	1-story w/	2007
New	Approved Basic 06-131030 BP	2003 IRC	Plan No. 1440	1-story w/attached	2007
New	Approved Basic 06-131030 BP	2003 IRC	Plan No. 1440	1-story w/attached	2007
New	Approved Basic 06-131030 BP	2003 IRC	Plan No. 1440	1-story w/attached	2007
New	New Split SFR w/ attached garage from Approved Basic 06-129890-BP	2003 IRC	Plan		2007
New	52 ft x 58 ft two story SFR over attached garage				2007
New	Approved Basic 06-101807 BP	2003 IRC	Plan: Orcas	Two-stor	2007
New	Approved Basic 07-104225 BP	2003 IRC	Plan: 1600H	Two-story sfr with attached gara	2007
New	Approved Basic 05-123957BP	2003 IRC	Plan:1852	SFR w/finished basement & attache	2007
New	Approved Basic 05-126099BP	2003 IRC	2 story SFR w/attached garage	Plan:1598	2007
New	Approved basic 07-107742 BP	2003 IRC	Plan# 1981 H	2-story sfr w/attached gar fi	2007
New	Approved Basic 07-104232 BP	2003 IRC	Plan: 1600G		2007
New	Rambler w/ daylight basement and attached 2 car garage				2007
New	Rambler w/ daylight basement and attached 2 car garage				2007
New	SENT PERMIT FOLDER TO RECORDS ROOM 11/24/08 DM			New 2 story SFR w/ attached garage	2007
New	Two Story SFR w/attached garage	2003 IRC	Plan: 1507		2007
New	Approved Basic 06-102296 BP	2003 IRC	Builders Plan: 2717 T		2007
New	APPROVED basic 07-107737 BP	2003 IRC	Plan# 1981 G	2-story sfr w/attached	2007
New	Approved Basic 07-104225 BP	2003 IRC	Plan: 1600H	Two-story sfr with attached gara	2007
New	Approved Basic 07-104232 BP	2003 IRC	Plan: 1600G	Two-story SFR with attached ga	2007
New	Approved Basic 05-123957BP	2003 IRC	Plan:1852	SFR w/finished basement & attache	2007
New	APPROVED basic 07-107737 BP	2003 IRC	Plan# 1981 G	2-story sfr w/attached	2007
New	Approved Basic 07-104225 BP	2003 IRC	Plan: 1600H	Two-story sfr with attached gara	2007
New	Approved Basic 05-123957BP	2003 IRC	Plan:1852	SFR w/finished basement & attache	2007

Accessory Dwelling Units

Index # - File Name: 1.0022 - Single Family Dwellings Data\_Snohomish County.pdf

New	Approved Basic 07-104225 BP	2003 IRC	Plan: 1600H	2007
New	2-Story SFR w/attached breezeway/garage.			2007
New	ACCESS BOND OK Duplex with attached garage and woodshop			2007
New	2-story sfr w/attached garage			2007
New	New one story SFR w/ attached garage			2007
New	Approved Basic 04-112102-BP	Mid-Entry w/finished basement	2003-IRC	2007
New	2143 sq ft Rambler with attached Garage			2007
New	Rambler style SFR w/ daylight finished basement and attached garage			2007
New	Approved basic 05-126654 BP	2003 IRC	Plan # 2009-3-55	2-story sfr w/attached gar
New	SENT PERMIT FOLDER TO RECORDS ROOM 11/26/08 DM	Two story SFR with attached Garage		2007
New	48 ft x 82 ft two story SFR with attached garage			2007
New	782 sq ft Finished Basement to SFR			2007
New	EXTENDED TO 7-15-09 TO OBTAIN FINAL INSPECTION 6/30/09 dm	Two Story SFR with Attached		2007
New	Rambler with daylight basement & attached garage			2007
New	On 2/20/08, this permit was transferred from Max Smith to Jay F. McArthur & Stacy I. Young	Tv		2007
New	Two-story sfr with attached garage			2007
New	EXPIRED WITHOUT COUNTY APPROVAL TO USE OR OCCUPY DM	Rambler style w/garage		2007
New	SFR with Attached Garage			2007
New	Two Story SFR with 637 SF Semi-Finished Basement			2007
New	54 ft x 80 ft two story SFR with attached garage	Future Reviews see comments		2007
New	2-story SFR w/garage			2007
New	2006 McKenzie Mobile Home			2007
New	4321 sq ft single family residence with 1462 basement and 724 sq ft garage.	Refunded \$60 re-ir		2007
New	2024sf rambler with attached 939sf garage - 2003 IRC			2007
New	one story SFR with attached garage, and rough in plumbing for radiant heat in unfinished basem			2007
New	Approved Basic 05- 128571BP	2003 IRC	Plan: 0123	Two-story S
New	SENT PERMIT FOLDER TO RECORDS ROOM 10/15/08 DM	Two-story sfr with attached garage		2007
New	SENT PERMIT FOLDER TO RECORDS ROOM 10/22/08 DM	Split-entry SFR residence with attache		2007
New	1978 14 ft X 52 ft Single-Wide MH			2007
New	2482 sq ft Rambler with attached Garage and 1365sf finished daylight basement	2003 IRC		2007
New	Approved Basic 05-116800BP	2003 IRC	Plan:1932- 3 Car	2 story SFR w/attached garage
New	Approved Basic 05-127779BP	2003 IRC	2 story SFR w/attached garage	Plan:2278
New	Approved Basic 04-120167BP	2 story SFR w/attached garage	2003 IRC	Plan:2597
New	Approved Basic 04-120167BP	2 story SFR w/attached garage	2003 IRC	Plan:2597
New	Approved Basic 05-116800BP	2003 IRC	Plan:1932- 3 Car	2007
New	Approved Basic 05-116799BP	2003 IRC	Plan:2597 3 Car	2 story SFR w/attached g
New	Approved Basic 05-116800BP	2003 IRC	Plan:1932- 3 Car	2007
New	Rambler style w/garage			2007
New	27 x 70 double wide MH			2007
New	Rambler style SFR w/garage			2007
New	Rambler-style SFR with attached garage - 2003 IRC			2007
New	2 story SFR w/ attached 3 car garage			2007
New	Proposed 27 x 60, 2006, Marlette Pacifica mobile home accessory apartment			2007
New	2 story home w/ attached 3 car garage			2007
New	40 ft x 40 ft SFR with attached garage			2007
New	New rambler with attached garage			2007
New	SENT PERMIT FOLDER TO RECORDS ROOM 11/26/08 DM	Approved Basic 07-103243 BP	2003 I	2007

Accessory Dwelling Units

Index # - File Name: 1.0022 - Single Family Dwellings Data\_Snohomish County.pdf

New	Approved Basic 07-103241 BP	2003 IRC	Plan: 35	2007
New	Approved Basic 07-103243 BP	2003 IRC	Plan: 30	2007
New	SENT PERMIT FOLDER TO RECORDS ROOM 12/01/08 DM Approved Basic 07-103241 BP			2007
New	Approved Basic 07-103241 BP	2003 IRC	Plan: 35	2007
New	*Issued under tax roll # 003731-005-002-01* 2 story SFR w/ attached garage			2007
New	*Issued under tax roll # 003731-005-002-01* 2 story SFR w/ attached garage			2007
New	SENT PERMIT FOLDER TO RECORDS ROOM 11/26/08 DM 2 story SFR w/ attached garage			2007
New	*Issued under tax roll # 003731-005-002-01* 2 story SFR w/ attached garage			2007
New	SENT PERMIT FOLDER TO RECORDS ROOM 11/26/08 DM *Issued under tax roll # 003731-005-0			2007
New	*Issued under tax roll # 003731-005-002-01* 2 Story SFR w/ finished basement and attached ga			2007
New	SENT PERMIT FOLDER TO RECORDS ROOM 10/27/08 DM 73 ft x 134 ft one story SFR with unfin			2007
New	Two-story SFR with attached garage & home office - 2003 IRC			2007
New	Approved Basic # 07--102424 BP	2003 IRC	Plan: 2011	Two story SFR with attached Garage 2007
New	Approved Basic # 07-102421-BP	2003 IRC	Plan: 2104	Two story SFR with attached Garage 2007
New	Approved Basic # 07--102424 BP	2003 IRC	Plan: 2011	Two story SFR with attached Garage 2007
New	Approved Basic # 07--102424 BP	2003 IRC	Plan: 2011	Two story SFR with attached Garage 2007
New	Approved Basic # 07- 102331-BP	2003 IRC	Plan: 1809	Two story SFR with attached Gara 2007
New	Approved Basic # 07--102424 BP	2003 IRC	Plan: 2011	Two story SFR with attached Garage 2007
New	Approved Basic # 07-102421-BP	2003 IRC	Plan: 2104	Two story SFR with attached Garage 2007
New	Approved Basic # 07-102421-BP	2003 IRC	Plan: 2104	Two story SFR with attached Garage 2007
New	Approved Basic # 07--102424 BP	2003 IRC	Plan: 2011	Two story SFR with attached Garage 2007
New	Approved Basic # 07- 102331-BP	2003 IRC	Plan: 1809	Two story SFR with attached Gara 2007
New	Approved Basic # 07-102421-BP	2003 IRC	Plan: 2104	Two story SFR with attached Garage 2007
New	Approved Basic # 07- 102331-BP	2003 IRC	Plan: 1809	Two story SFR with attached Gara 2007
New	Approved Basic # 07-102421-BP	2003 IRC	Plan: 2104	Two story SFR with attached Garage 2007
New	Approved Basic # 07- 102331-BP	2003 IRC	Plan: 1809	Two story SFR with attached Gara 2007
New	Approved Basic # 07-102421-BP	2003 IRC	Plan: 2104	Two story SFR with attached Garage 2007
New	SENT PERMIT FOLDER TO RECORDS ROOM 11/24/08 DM Approved Basic # 07- 102331-BP 200			2007
New	Approved Basic # 07--102424 BP	2003 IRC	Plan: 2011	Two story SFR with attached Garage 2007
New	SENT PERMIT FOLDER TO RECORDS ROOM 11/24/08 DM Approved Basic # 07- 102331-BP 200			2007
New	SENT PERMIT FOLDER TO RECORDS ROOM 11/26/08 DM Approved Basic # 07- 102331-BP 200			2007
New	SENT PERMIT FOLDER TO RECORDS ROOM 11/26/08 DM Approved Basic # 07--102424 BP 200			2007
New	SENT PERMIT FOLDER TO RECORDS ROOM 11/26/08 DM Approved Basic # 07-102421-BP 200			2007
New	SENT PERMIT FOLDER TO RECORDS ROOM 11/26/08 DM Approved Basic # 07- 102331-BP 200			2007
New	Approved Basic # 07--102424 BP	2003 IRC	Plan: 2011	Two story SFR with attached Garage 2007
New	SENT PERMIT FOLDER TO RECORDS ROOM 11/26/08 DM Approved Basic # 07-102421-BP 200			2007
New	SENT PERMIT FOLDER TO RECORDS ROOM 11/26/08 DM Single Story single family residence wi			2007
New	SENT PERMIT FOLDER TO RECORDS ROOM 12/01/08 DM Rambler with Attached Garage			2007
New	SENT PERMIT FOLDER TO RECORDS ROOM 12/01/08 DM 2-story SFR w/garage			2007
New	SENT PERMIT FOLDER TO RECORDS ROOM 12/01/08 DM Approved Basic 07-111768-BP PI			2007
New	SENT PERMIT FOLDER TO RECORDS ROOM 12/01/08 DM Approved Basic 07-111771-BP Pla			2007
New	SENT PERMIT FOLDER TO RECORDS ROOM 12/01/08 DM Approved Basic 07-111764-BP Plan N			2007
New	Approved Basic 06-104052BP	2003 IRC	2 story SFRw/attached garage	Paln:3376A2 2007
New	Rambler w/ finished daylight basement & attached 3 car Garage			2007
New	Approved Basic #05-126865BP	2003 IRC	Plan: MV3-3568 AB	2-story SFR with finished E 2007
New	SENT PERMIT FOLDER TO RECORDS ROOM 11/24/08 DM Approved Basic #05-126865BP 200			2007
New	SENT PERMIT FOLDER TO RECORDS ROOM 11/21/08 DM Two-story SFR with attached garage -			2007

Accessory Dwelling Units

Index # - File Name: 1.0022 - Single Family Dwellings Data\_Snohomish County.pdf

New	SENT PERMIT FOLDER TO RECORDS ROOM 11/21/08 DM	Two story home, 4 bedroom w/ bonu	2007
New	Approved Basic 04-115137BP	2 story SFR w/attached garage 2003 IRC Plan:50070-A3T	2007
New	SENT PERMIT FOLDER TO RECORDS ROOM 11/21/08 DM	Two story home, 4 bedroom w/ bonu	2007
New	Two-story residence with attached garage		2007
New	Approved Basic # 07- 102331-BP	2003 IRC Plan: 1809 Two story SFR with attached Gara	2007
New	2478 sq ft single family residence		2007
New	2 story SFR w/ attached garage		2007
New	Approved basic 06-133178 BP	2003 IRC Plan# 2648 2-story sfr w/attached garage	2007
New	Approved basic 05-124400 BP	2003 IRC Plan# 3098 2-story sfr w/attached garage	2007
New	Approved Basic 04-115824BP	2 story SFR w/attached garage 2003 IRC Plan:2611	2007
New	SENT PERMIT FOLDER TO RECORDS ROOM 12/01/08 DM	Approved Basic 04-115827BP 2 story	2007
New	Approved Basic 05-125238BP	2003 IRC 2 story SFR w/attached garage Plan:3041	2007
New	Approved Basic # 07-101943 BP	2003 IRC Plan: 3514 Two story SFR with attached C	2007
New	Approved Basic 07-113305-BP	Plan No. 2401 C 2006 IRC 2 story SFR w/ attached garage	2007
New	Approved Basic 07-112337-BP	Plan No. 2021 A 2006 IRC 2 story SFR w/ 2 or 3 car garage o	2007
New	Approved Basic 07-111145-BP	2006 IRC Plan # 2155 B 2- Story SFR w/ attached g	2007
New	Approved Basic 04-117263BP	2 story SFR w/attached garage 2003 IRC Plan:3131B	2007
New	Approved Basic 07-109673-BP	Builder No. 1623 C 2006 IRC / WSEC Rambler SFR w/ attac	2007
New	Approved Basic 07-109652-BP	Builder No. 2343 A 2006 IRC / WSEC 2 story SFR with :	2007
New	Approved basic 07-112908 BP	2006 IRC Plan# 2731 B 2-story sfr w/attached	2007
New	Approved basic 07-110761 BP	2006 IRC Plan# 2531 C 2-story sfr w/attached gara	2007
New	Approved Basic 07-109652-BP	Builder No. 2343 A 2006 IRC / WSEC 2 story SFR with :	2007
New	Approved basic 06-129773 BP	2003 IRC Plan# 2957 B 2-story sfr w/attached g	2007
New	Approved basic 06-129771 BP	2003 IRC Plan # 3154 B 2-story sfr w/attached gara	2007
New	Approved basic 06-129775 BP	2003 IRC Plan# 3216 A 2-story sfr w/attached garage	2007
New	Approved basic 06-129776 BP	2003 IRC Plan# 3216 A 2-story sfr w/attache	2007
New	Approved Basic #07-110533	2006 IRC Plan:3154 A & B 2 story SFR	2007
New	Approved Basic #07-110533	2006 IRC Plan:3154 A & B 2 story SFR	2007
New	Two-story residence		2007
New	Approved Basic #07-110534BP	2006 IRC Plan:3216A 2 story SFR	2007
New	Approved Basic 06-130854-BP	2003 IRC Plan # 2-1516 2-story sfr w/ attached garage	2007
New	Single family residence w/attached garage.		2007
New	Approved Basic 06-130854-BP	2003 IRC Plan # 2-1516 2-story sfr w/ attached garage	2007
New	Approved Basic 04-118819BP	2 story SFR w/attached garage 2003 IRC Plan:C4	2007
New	Approved Basic 05-118698BP	2005 IRC 2 story SFR w/attached garage Plan:BA	2007
New	Approved Basic 05-118703BP	2003 IRC 2 story SFR w/attached garage Plan:K-B	2007
New	Approved Basic 05-118698BP	2003 IRC 2 story SFR w/attached garage Plan:BA	2007
New	Approved Basic 07-106359-BP	2006 IRC Plan # Bordeaux 2-story SFR w/ atta	2007
New	*Issued under tax roll # 005092-002-016-00*	New SFR 2 story w/ attached garage ( similar to k	2007
New	*Issued under tax roll # 005092-002-016-00*	New SFR 2 story with attached garage	2007
New	Two-story SFR with finished basement with attached garage with 841sf	2nd floor guest loft - 20	2007
New	*Issued under tax roll # 003731-005-002-01*	2 Story SFR w/ attached garage	2007
New	2-story SFR w/garage		2007
New	2 story home w/ attached 3 car garage		2007
New	70 ft x 88 ft two story SFR with attached garage		2007
New	Approved basic 06-129078 BP	2003 IRC Plan# 2838 2 story with attached 3 car gara	2007
New	Approved Basic 07-110149 BP	2006 IRC Plan: 3016A Two-st	2007

Accessory Dwelling Units

Index # - File Name: 1.0022 - Single Family Dwellings Data\_Snohomish County.pdf

New	Approved Basic 07-110857-BP	2006 IRC	Plan # 2996 A	2-Story SFR w/ attached g	2007
New	Approved Basic 07-110856-BP	2006 IRC	Plan #2996B	2-Story SFR w/ attached	2007
New	2 story SFR w/ attached garage				2007
New	Rambler with attached garage				2007
New	SENT PERMIT FOLDER TO RECORDS ROOM 11/26/08 DM			2-story SFR w/garage	2007
New	64 ft x 66 ft one story SFR with attached garage				2007
New	42 ft x 60 ft two story SFR with attached garage				2007
New	Rambler with daylight basement and attached garage				2007
New	Two-story residence with attached garage				2007
New	Two-story residence with attached garage				2007
New	Approved Basic 04-118819BP	2 story SFR w/attached garage	2003 IRC	Plan:C4	2007
New	Approved Basic 05-118703BP	2003 IRC	2 story SFR w/attached garage	Plan:K-B	2007
New	Approved Basic 05-118701BP	2003 IRC	2 story SFR w/attached garage	Plan:KA	2007
New	SENT PERMIT FOLDER TO RECORDS ROOM 11/24/08 DM			2 Story SFR w/attached garage.	2007
New	Two story SFR with attached Garage				2007
New	New two story SFR w/ attached garage				2007
New	SENT PERMIT FOLDER TO RECORDS ROOM 11/21/08 DM	Approved basic 06-133428 BP	2003		2007
New	Approved basic 06-133428 BP	2003 IRC	Plan# 497 - 2 A, B, C	2-story sfr w/attached	2007
New	Approved basic 06-133128 BP	2003 IRC	Plan# 496-2 A,B,C	2-story sfr w/attached	2007
New	Approved basic 06-133124 BP	2003 IRC	Plan# 494-2 A,B,C	2-story sfr w/attached	2007
New	Approved basic 06-133428 BP	2003 IRC	Plan# 497 - 2 A, B, C	2-story sfr w/attached	2007
New	Approved basic 06-133128 BP	2003 IRC	Plan# 496-2 A,B,C	2-story sfr w/attached	2007
New	Approved basic 06-133124 BP	2003 IRC	Plan# 494-2 A,B,C	2-story sfr w/attached	2007
New	Approved basic 06-133128 BP	2003 IRC	Plan# 496-2 A,B,C	2-story sfr w/attached	2007
New	Approved Basic 06-135715BP	2003 IRC	Two-story SFR with 2-car garage	Plan: 625-2A-B-C	2007
New	Approved basic 06-133124 BP	2003 IRC	Plan# 494-2 A,B,C	2-story sfr w/attached	2007
New	Approved basic 06-133428 BP	2003 IRC	Plan# 497 - 2 A, B, C	2-story sfr w/attached	2007
New	Approved basic 06-133124 BP	2003 IRC	Plan# 494-2 A,B,C	2-story sfr w/attached	2007
New	Approved basic 06-133128 BP	2003 IRC	Plan# 496-2 A,B,C	2-story sfr w/attached	2007
New	Approved basic 06-133428 BP	2003 IRC	Plan# 497 - 2 A, B, C	2-story sfr w/attached	2007
New	Approved basic 06-133128 BP	2003 IRC	Plan# 496-2 A,B,C	2-story sfr w/attached	2007
New	Approved basic 06-133124 BP	2003 IRC	Plan# 494-2 A,B,C	2-story sfr w/attached	2007
New	Approved basic 06-133428 BP	2003 IRC	Plan# 497 - 2 A, B, C	2-story sfr w/attached	2007
New	Approved basic 06-133128 BP	2003 IRC	Plan# 496-2 A,B,C	2-story sfr w/attached	2007
New	Approved basic 06-133124 BP	2003 IRC	Plan# 494-2 A,B,C	2-story sfr w/attached	2007
New	Approved basic 06-133428 BP	2003 IRC	Plan# 497 - 2 A, B, C	2-story sfr w/attached	2007
New	Approved basic 06-133128 BP	2003 IRC	Plan# 496-2 A,B,C	2-story sfr w/attached	2007
New	Approved basic 06-133124 BP	2003 IRC	Plan# 494-2 A,B,C	2-story sfr w/attached	2007
New	Approved basic 06-133428 BP	2003 IRC	Plan# 497 - 2 A, B, C	2-story sfr w/attached	2007
New	Approved basic 06-133128 BP	2003 IRC	Plan# 496-2 A,B,C	2-story sfr w/attached	2007
New	Approved Basic 06-135715BP	2003 IRC	Two-story SFR with 2-car garage	Plan: 625-2A-B-C	2007
New	Approved Basic 06-135715BP	2003 IRC	Two-story SFR with 2-car garage	Plan: 625-2A-B-C	2007
New	Approved basic 06-133428 BP	2003 IRC	Plan# 497 - 2 A, B, C	2-story sfr w/attached	2007
New	Approved basic 06-133124 BP	2003 IRC	Plan# 494-2 A,B,C	2-story sfr w/attached	2007

Accessory Dwelling Units

Index # - File Name: 1.0022 - Single Family Dwellings Data\_Snohomish County.pdf

New	Approved basic 06-133128 BP	2003 IRC	Plan# 496-2 A,B,C	2-story sfr w/attached	2007
New	Approved Basic 06-135715BP	2003 IRC	Two-story SFR with 2-car garage	Plan: 625-2A-B-C	2007
New	2,637 sq ft Rambler with attached Garage				2007
New	2 Story SFR w/ attached garage.	2006 IRC			2007
New	SENT PERMIT FOLDER TO RECORDS ROOM 10/28/08 DM			2-story sfr w/attached garage	2007
New	SENT PERMIT FOLDER TO RECORDS ROOM 10/28/08 DM			2-story sfr w/attached garage	2007
New	2-story sfr w/attached garage				2007
New	SENT PERMIT FOLDER TO RECORDS ROOM 10/28/08 DM			2-story sfr w/attached garage	2007
New	2-story sfr w/attached garage				2007
New	*Issued under tax roll # 004708-000-008-00*			2 story duplex with attached garage	2007
New	*Issued under tax roll # 004708-000-008-00*	Approved Basic # 07-	110070-BP	2006 IRC	P 2007
New	Approved basic 06-129045 BP	2003 IRC	Plan# 3105	2-story sfr w/attached garage	2007
New	2-Story SFR w/attached garage.				2007
New	Two story SFR with attached Garage				2007
New	Rambler style, 4 bedroom home with attached 3 car garage				2007
New	Approved Basic # 06-129178 BP	2003 IRC	Plan: 2370	Rambler w/ attached Garage	2007
New	Approved basic 05-124812 BP	2003 IRC	Plan# 2802 conv	2-story sfr w/attached	2007
New	Approved basic 05-123186 BP	2003 IRC	Plan# 2760	2-story sfr w/attached garage	2007
New	Approved basic 05-123186 BP	2003 IRC	Plan# 2760	2-story sfr w/attached garage	2007
New	SENT PERMIT FOLDER TO RECORDS ROOM 11/24/08 DM			Approved basic 06-131358 BP	2007
New	SENT PERMIT FOLDER TO RECORDS ROOM 12/01/08 DM			Approved basic 05-122932 BP	2007
New	Approved Basic 07-104092-BP	2003 IRC	Plan # Palisade Gable B	2-story SFR w/ att	2007
New	Approved basic 06-133587 BP	2003 IRC	Plan# Hazelwood Gable B	2-story sfr w/attach	2007
New	Approved basic 07-102610 BP	2003 IRC	Plan# Jefferson Gable B (I)	2-story sfr	2007
New	Approved Basic # 07-100656 BP	2003 IRC	Plan: Wrangell Gable A (I)	Two story SFR with attac	2007
New	Approved basic 07-102607 BP	2003 IRC	Plan# Mansfield Hip B (I)	2-story sfr w/ai	2007
New	Approved basic 07-102610 BP	2003 IRC	Plan# Jefferson Gable B (I)	2-story sfr	2007
New	Approved Basic 07-100659 BP	2003 IRC	Plan: Gable A (I)	Two story SFR with attached G	2007
New	Approved basic 07-102608 BP	2003 IRC	Plan# Jefferson Gable A (I)	2-story sfr w	2007
New	Approved basic 07-102603 BP	2003 IRC	Plan# Appleton Gable A (I)	2-story sfr w/at	2007
New	Approved Basic 07-100143 BP	2003 IRC	Plan: Logan Gable B(I)	1	2007
New	Approved Basic 07-100145 BP	2003 IRC	Plan: Langley Hip A(I)	T	2007
New	Approved Basic 07-100142 BP	2003 IRC	Plan: Granite Hip A(I)	T	2007
New	Approved Basic 07-100143 BP	2003 IRC	Plan: Logan Gable B(I)	1	2007
New	Approved Basic # 07-100660 BP	2003 IRC	Plan: Wrangell Gable B (I)	Two story SFR with attac	2007
New	Approved basic 07-102611BP -	2003 IRC	Plan# Monroe Gable A (1)	2-story sfr w/attached	2007
New	Approved Basic #07-107188 BP	Plan: Crestone Gable II A	2003 IRC	2-Story SFR w/ attach	2007
New	Approved 07-102605 BP	2003 IRC	Plan# Glacier Gable B (I)	2-story sfr w/attached	2007
New	Approved Basic 07-104090-BP	2003 IRC	Plan # Appalachian Hip B	2-story SFR w/ at	2007
New	Approved basic 06-133592 BP	2003 IRC	Plan# Shasta Gable	2-story sfr w/attached ga	2007
New	Approved Basic # 07-100656 BP	2003 IRC	Plan: Wrangell Gable A (I)	Two story SFR with attac	2007
New	Approved basic 07-102606 BP	2003 IRC	Plan# Mansfield Hip A (I)	2-story sfr w/a	2007
New	Approved Basic # 07-100660 BP	2003 IRC	Plan: Wrangell B	2-story SFR with attached Garag	2007
New	Approved Basic 07-100135 BP	2003 IRC	Plan: Hazelwood Gable A(I)	Two-story SFR w/attach	2007
New	Approved Basic # 07-100656 BP	2003 IRC	Plan: Wrangell Gable A (I)	Two story SFR with attac	2007
New	Approved basic 06-133592 BP	2003 IRC	Plan# Shasta Gable	2-story sfr w/attached ga	2007
New	Approved Basic 07-100145 BP	2003 IRC	Plan: Langley Hip A(I)	T	2007

Accessory Dwelling Units

Index # - File Name: 1.0022 - Single Family Dwellings Data\_Snohomish County.pdf

New	156 sq ft 2nd floor bonus room				2007
New	Approved basic 06-134178 BP	2003 IRC	Plan# Purcell Gable A (I)	2-story sfr w/attached	2007
New	Approved Basic 07-101418 BP	2003 IRC	Plan: Waterton Gable A (I)	Two-story home w/atta	2007
New	Approved Basic 07-101419 BP	2003 IRC	Plan: Madison Hip B (I)	Two-story home w/attache	2007
New	Approved Basic 07-104092-BP	2003 IRC	Plan # Palisade Gable B(I)	2-story SFR w/ a	2007
New	Approved basic 07-102605 BP -	2003 IRC	Plan# Glacier Gable B (I)	2-story sfr w/attached ga	2007
New	Approved Basic 07-101419 BP	2003 IRC	Plan: Madison Hip B (I)	Two-story home w/attache	2007
New	Approved basic 06-133592 BP	2003 IRC	Plan# Shasta Gable	2-story sfr w/attached ga	2007
New	Approved 07-102605 BP	2003 IRC	Plan# Glacier Gable B (I)	2-story sfr w/attached	2007
New	Approved Basic #07-105839 BP	Plan: Langley II Hip B (I)	2003 IRC	Two Story SFR	2007
New	Approved 07-102605 BP	2003 IRC	Plan# Glacier Gable B (I)	2-story sfr w/attached	2007
New	Approved basic 06-133592 BP	2003 IRC	Plan# Shasta Gable	2-story sfr w/attached ga	2007
New	Approved Basic 07-100145 BP	2003 IRC	Plan: Langley Hip A(I)	T	2007
New	Approved basic 06-133587 BP	2003 IRC	Plan# Hazelwood Gable B	2-story sfr w/attached gar	2007
New	Approved Basic 07-100131BP	2003 IRC	Two-story SFR	Plan: Lafayette Gable A (I)	App
New	Approved Basic 07-104094-BP	2003 IRC	Plan # Granite Hip B	2-Story SFR w/ a	2007
New	Approved basic 06-134179 BP	2003 IRC	Plan# Lafayette Gable B (I)	2-story sfr w/atta	2007
New	Approved Basic 07-100147 BP	2003 IRC	Plan: Selkirk Gable A(I)		2007
New	Approved Basic 07-100148 BP	2003 IRC	Plan: Crestone Gable B(I)		2007
New	Approved basic 07-102608 BP	2003 IRC	Plan# Jefferson Gable A (I)	2-story sfr w	2007
New	Approved basic 07-102611 BP -	2003 IRC	Plan# Monroe Gable A (I)	2-story sfr w/attached g	2007
New	SENT PERMIT FOLDER TO RECORDS ROOM 11/26/08 DM	Approved Basic 07-105839 BP	Pla		2007
New	Approved Basic #07-107188 BP	Plan: Crestone Gable II A	2003 IRC	2-Story SFR w/ attach	2007
New	Approved 07-102605 BP	2003 IRC	Plan# Glacier Gable B (I)	2-story sfr w/attached	2007
New	Approved Basic 07-104092-BP	2003 IRC	Plan # Palisade Gable B(I)	2-story SFR w/ a	2007
New	Approved basic 07-102605 BP -	2003 IRC	Plan# Glacier Gable B (I)	2-story sfr w/attached g	2007
New	Approved Basic 07-100145 BP	2003 IRC	Plan: Langley Hip A(I)	T	2007
New	Approved Basic 07-100138 BP	2003 IRC	Plan: Adams Gable B(I)		2007
New	Approved Basic 06-134968BP -	2003IRC	Two-story SFR with attached garage	Plan: Langley Hip	2007
New	Approved basic 06-133935 BP	2003 IRC	Plan# Adams Gable A (I)	2-story sfr w/attacl	2007
New	Approved basic 06-134178 BP	2003 IRC	Plan# Purcell Gable A (I)	2-story sfr w/attached	2007
New	Approved Basic # 07-100660 BP	2003 IRC	Plan: Wrangell Gable B (I)	Two story SFR with attacl	2007
New	Approved basic 06-134178 BP	2003 IRC	Plan# Purcell Gable A (I)	2-story sfr w/attached	2007
New	Approved Basic 07-100141 BP	2003 IRC	Plan: Trinity Gable A(I)		2007
New	Approved basic 06-133587 BP	2003 IRC	Plan# Hazelwood Gable B	2-story sfr w/attac	2007
New	Approved basic 06-133934 BP	2003 IRC	Plan# Shasta Gable A (I)	2-story sfr w/attache	2007
New	1930 sq ft SFR with 523 sq ft finished Basement & attached Garage				2007
New	Approved Basic 07-100131BP	2003 IRC	Two-story SFR	Plan: Lafayette Gable A (I)	2007
New	Approved Basic 07-100132 BP	2003 IRC	Plan: Purcell Gable B(I)		2007
New	Approved Basic 07-100135 BP	2003 IRC	Plan: Hazelwood Gable A(I)		2007
New	1030 sq ft single family residence.				2007
New	Approved basic 06-130545 BP	2003 IRC	Plan# 2060	2-story sfr w/attached garage	2007
New	890 square foot garage with 791 square foot SFR above				2007
New	Approved basic 07-101882 BP	2003 IRC	Plan# ARM1	2-story sfr w/attached garage	2007
New	Approved basic 07-101882 BP	2003 IRC	Plan# ARM1	2-story sfr w/attached garage	2007
New	1957 sq ft SFR with 392 sq ft attached garage.				2007
New	Two story SFR with attached Garage				2007



Accessory Dwelling Units

Index # - File Name: 1.0022 - Single Family Dwellings Data\_Snohomish County.pdf

New	Approved basic 05-124400 BP	2003 IRC	Plan# 3098	2-story sfr w/attached garage	2007
New	27x48, 2006 Palm Harbor				2007
New	Approved basic 05-119652 BP	2003 IRC	Plan# 3066	2-story SFR w/attached gara	2007
New	Approved basic 06-133178 BP	2003 IRC	Plan# 2648	2-story sfr w/attached garage	2007
New	2665 sq ft single family residence with 690 sq ft attached garage.				2007
New	Approved basic 06-130553 BP	2003 IRC	Plan# 2740	2-story sfr w/attached garage	2007
New	2-story sfr w/attached garge				2007
New	Approved basic 06-130879 BP	2003 IRC	Plan# 2648-2400	Rambler w/attached ga	2007
New	Approved basic 06-133587 BP	2003 IRC	Plan# Hazelwood Gable B	2-story sfr w/attached gar:	2007
New	Approved basic 06-134179 BP	2003 IRC	Plan# Lafayette Gable B (I)	2-story sfr w/atta	2007
New	Approved basic 06-134177 BP	2003 IRC	Plan# Waterton Gable B (I)	2-story sfr w/attach	2007
New	Approved Basic #07-105838 BP	Plan: Langley Hip II A (I)	2003 IRC	Two Story SFR	2007
New	Approved basic 07-102604 BP	2003 IRC	Plan# Appleton Gable B (I)	2-story sfr w/at	2007
New	Approved Basic #07-105838 BP	Plan: Langley Hip II A (I)	2003 IRC	Two Story SFR	2007
New	Approved Basic # 07-100656 BP	2003 IRC	Plan: Wrangell Gable A (I)	Two story SFR with attach	2007
New	APPROVED Basic #07-105840 BP	Plan: Monroe Gable B (I)	2003 IRC	Two Story SFR **or	2007
New	Approved basic 06-133592 BP	2003 IRC	Plan# Shasta Gable	2-story sfr w/attached ga	2007
New	Two-story residence with attached garage				2007
New	SENT PERMIT FOLDER TO RECORDS ROOM 12/01/08 DM	Approved Basic # 07-110601 BP	2006		2007
New	EXPIRED WITHOUT COUNTY APPROVAL TO USE OR OCCUPY 6/2/09 DM	Approved Basic # 07-110601 BP	2006		2007
New	2-Story single family residence with attached 3-car garage,				2007
New	Approved Basic 05-100867 BP	2003 IRC	Plan: MU3DB-3170	Two-stor	2007
New	Approved Basic 05-120109BP	2003 IRC	2 story SFR w/attached garage	Plan:3025A	2007
New	SENT PERMIT FOLDER TO RECORDS ROOM 11/26/08 DM	Two story SFR with attached Garage			2007
New	SENT PERMIT FOLDER TO RECORDS ROOM 11/26/08 DM	2-Story SFR w/attached garage.			2007
New	SENT PERMIT FOLDER TO RECORDS ROOM 11/24/08 DM	Approved basic 05-127371 BP	2006		2007
New	Approved basic 07-110023 BP	2006 IRC	Plan# 2046A	2-story sfr w/attached g	2007
New	Approved Basic #07-106844 BP	2006 IRC	Plan: 2912 A	Two Story SFR w/attached garage	2007
New	SENT PERMIT FOLDER TO RECORDS ROOM 12/01/08 DM	Approved basic 07-108994 BP	2006		2007
New	Approved basic 07-106996 BP	2006 IRC	Plan# 2243 B	2-story sfr w/attached ga	2007
New	Approved basic 07-106990 BP	2006 IRC	Plan# 2520 B	2-story sfr w/attache	2007
New	Approved Basic #07-106843 BP	2006 IRC	Plan: 2520 B	Two Story SFR w/attached garage	2007
New	Approved Basic #07-106846 BP	2006 IRC	Plan: 2344 A	Two Story SFR w/attached garage	2007
New	Approved Basic 07-106362-BP	2006 IRC	Plan #2685A	2-Story SFR w/ attached gar	2007
New	Approved Basic 07-106992 BP	2006 IRC	Plan# 2912 B	2-story sfr w/attached ga	2007
New	Approved Basic 07-106355-BP	2006 IRC	Plan #2685B	2-Story SFR w/ attached gar	2007
New	Approved Basic #07-106842 BP	2006 IRC	Plan: 2520 A	Two Story SFR w/attached garage	2007
New	Two-story SFR with attached garage - 2003 IRC				2007
New	Approved basic 07-106996 BP	2006 IRC	Plan# 2243 B	2-story sfr w/attached ga	2007
New	Approved basic 07-106990 BP	2006 IRC	Plan# 2520 B	2-story sfr w/attache	2007
New	Approved Basic 07-109288-BP	2006 IRC	Plan # 2243A	2-Story SFR w/ attached ga	2007
New	Approved Basic #07-106842 BP	2006 IRC	Plan: 2520 A	Two Story SFR w/attached garage	2007
New	Approved basic 07-110023 BP	2006 IRC	Plan# 2046A	2-story sfr w/attached ga	2007
New	Approved Basic #07-106842 BP	2006 IRC	Plan: 2520 A	Two Story SFR w/attached garage	2007
New	Approved Basic 07-109288-BP	2006 IRC	Plan # 2243A	2-Story SFR w/ attached ga	2007
New	Approved basic 07-110027 BP	2006 IRC	Plan# 1934A	2-story sfr w/attached g	2007
New	Approved Basic 07-102420 BP	2003 IRC	Plan: 3023 B		2007

Accessory Dwelling Units

Index # - File Name: 1.0022 - Single Family Dwellings Data\_Snohomish County.pdf

New	Approved Basic 05-119591BP	2003 IRC	2 story SFR w/attached garage	Plan:302	2007
New	Approved Basic 05-120110BP	2003 IRC	2 story SFR w/attached garage	Plan:302	2007
New	Approved basic 05-121188 BP	2003 IRC	Plan# 4010D-C 2-story sfr w/attached garage		2007
New	Approved Basic 05-119592BP	2003 IRC	2 story SFR w/attached garage	Plan:3024B	2007
New	Approved Basic 05-119586BP	2003 IRC	2 story SFR w/attached garage	Plan:3022E	2007
New	Approved Basic 05-119584BP	2003 IRC	2 story SFR w/attached garage	Plan:3022A	2007
New	Approved Basic 07- BP	2003 IRC	Plan: 3028 A Two-story sfr with attached garage		2007
New	Approved Basic 07-106363-BP	2006 IRC	Plan #2685B 2-Story SFR w/ attached garage		2007
New	Approved basic 07-110959 BP	2006 IRC	Plan# 1934 B 2-story sfr w/attached garage		2007
New	Approved Basic 05-119590BP	2003 IRC	2 story SFR w/attached garage	Plan:3023A	2007
New	Approved Basic 07-102404 BP	2003 IRC	Plan: 3028 B Two-story sfr with attached garage		2007
New	Approved Basic 05-119584BP	2003 IRC	2 story SFR w/attached garage	Plan:3022A	2007
New	SENT PERMIT FOLDER TO RECORDS ROOM 11/26/08 DM Approved Basic 05-120109BP				2007
New	Approved Basic 05-119586BP	2003 IRC	2 story SFR w/attached garage	Plan:3022E	2007
New	Approved Basic 07-102404 BP	2003 IRC	Plan: 3028 B Two-story sfr with attached garage		2007
New	Approved Basic 05-119824BP	2003 IRC	2 story SFR w/attached garage	Plan:3026A	2007
New	Approved Basic 05-119591BP	2003 IRC	2 story SFR w/attached garage	Plan:302	2007
New	Approved Basic 05-119584BP	2003 IRC	2 story SFR w/attached garage	Plan:3022A	2007
New	Approved Basic 05-119588BP	2003 IRC	2 story SFR w/attached garage	Plan:302	2007
New	Approved Basic 05-120107BP	2003 IRC	2 story SFR w/attached garage	Plan:3027-B	2007
New	Approved Basic 05-119591BP	2003 IRC	2 story SFR w/attached garage	Plan:302	2007
New	Approved basic 05-121188 BP	2003 IRC	Plan# 4010D-C 2-story sfr w/attached garage		2007
New	Approved Basic 05-119825BP	2005 IRC	2 story SFR w/attached garage	Plan:3026	2007
New	Approved Basic 05-119586BP	2003 IRC	2 story SFR w/attached garage	Plan:3022E	2007
New	Approved Basic 05-119592BP	2003 IRC	2 story SFR w/attached garage	Plan:3024B	2007
New	Approved Basic 05-120110BP	2003 IRC	2 story SFR w/attached garage	Plan:302	2007
New	Approved basic 05-121187 BP	2003 IRC	Plan#4010D-B 2-story sfr w/attached garage		2007
New	Approved Basic 05-120105BP	2003 IRC	2 story SFR w/attached garage	Plan:30	2007
New	Approved Basic 05-120109BP	2003 IRC	2 story SFR w/attached garage	Plan:3025A	2007
New	Approved Basic 05-119825BP	2005 IRC	2 story SFR w/attached garage	Plan:3026	2007
New	Approved Basic 05-120105BP	2003 IRC	2 story SFR w/attached garage	Plan:30	2007
New	Approved basic 05-121187 BP	2003 IRC	Plan# 4010D-B 2-story sfr w/attached garage		2007
New	Approved Basic 05-119592BP	2003 IRC	2 story SFR w/attached garage	Plan:3024B	2007
New	Approved Basic # 07-102658 BP	2003 IRC	Plan: 3914-B Two story SFR with attached Garage		2007
New	Approved Basic # 07-102659 BP	2003 IRC	Plan: 3915-A Two story SFR with attached Garage		2007
New	Approved Basic 05-119591BP	2003 IRC	2 story SFR w/attached garage	Plan:302	2007
New	Approved Basic # 07-102657 BP	2003 IRC	Plan: 3914-A Two story SFR with attached Garage		2007
New	Approved Basic 05-119586BP	2003 IRC	2 story SFR w/attached garage	Plan:3022E	2007
New	Approved Basic # 07-102656 BP	2003 IRC	Plan: 3913-B Two story SFR with attached Garage		2007
New	Approved Basic #05-119590 BP	2003 IRC	2 story SFR w/attached garage	Plan: 2023 A	2007
New	Approved Basic # 07-102659 BP	2003 IRC	Plan: 3915-A Two story SFR with attached Garage		2007
New	Approved Basic 05-119584BP	2003 IRC	2 story SFR w/attached garage	Plan:3022A	2007
New	Approved Basic #05-119588 BP	2003 IRC	2 story SFR w/attached garage	Plan: 3023 B	2007
New	Approved Basic 05-119591BP	2003 IRC	2 story SFR w/attached garage	Plan:302	2007
New	Approved Basic 05-119586BP	2003 IRC	2 story SFR w/attached garage	Plan:3022E	2007
New	Approved Basic # 07-102659 BP	2003 IRC	Plan: 3915-A Two story SFR with attached Garage		2007
New	Approved Basic #05-119590 BP	2003 IRC	2 story SFR w/attached garage	Plan: 3023 A	2007

Accessory Dwelling Units

Index # - File Name: 1.0022 - Single Family Dwellings Data\_Snohomish County.pdf

New	Approved Basic # 07-102658 BP	2003 IRC	Plan: 3914-B	Two story SFR with attached Garage	2007
New	Approved Basic # 07-102660 BP	2003 IRC	Plan: 3915-B	Two story SFR with attached Garage	2007
New	Approved Basic 05-119584BP	2003 IRC		2 story SFR w/attached garage Plan:3022A	2007
New	Approved Basic # 07-102653 BP	2003 IRC	Plan: 3913-A	Two story SFR with attached Gara	2007
New	Approved Basic # 07-102657 BP	2003 IRC	Plan: 3914-A	Two story SFR with attached Garage	2007
New	Approved Basic 05-119584BP	2003 IRC		2 story SFR w/attached garage Plan:3022A	2007
New	Approved Basic # 07-102660 BP	2003 IRC	Plan: 3915-B	Two story SFR with attached Garage	2007
New	Approved Basic #05-119588 BP	2003 IRC		2 story SFR w/attached garage Plan: 2023 B	2007
New	Approved Basic # 07-102658 BP	2003 IRC	Plan: 3914-B	Two story SFR with attached Garage	2007
New	Approved Basic 05-119592BP	2003 IRC		2 story SFR w/attached garage Plan:3024B	2007
New	Approved Basic # 07-102653 BP	2003 IRC	Plan: 3913-A	Two story SFR with attached Gara	2007
New	Approved Basic 05-119590 BP	2003 IRC	Plan: 3023 A	2-story sfr with attached garage	2007
New	Approved Basic 07-104665-BP	2003 IRC	Plan # 4010D-B	2-Story SFR w/ attached g	2007
New	Two story SFR with attached Garage				2007
New	Approved Basic 06-135398 BP	2003 IRC	Plan: 2338	2-story residence with garag	2007
New	Approved basic 05-126370 BP	2003 IRC	Plan # 226-1007	2-story sfr w/attached gara	2007
New	SENT PERMIT FOLDER TO RECORDS ROOM 12/01/08 DM Approved Basic 06-135398 BP 200				2007
New	Approved basic 05-126373 BP	2003 IRC	Plan # 226-1001	2-story sfr w/attached gara	2007
New	Approved basic 05-126373 BP	2003 IRC	Plan # 226-1001	2-story sfr w/attached gara	2007
New	Approved basic 05-126370 BP	2003 IRC	Plan # 226-1007	2-story sfr w/attached gara	2007
New	Approved Basic 06-135398 BP	2003 IRC	Plan: 2338	2-story residence with garag	2007
New	2-story sfr w/attached garage				2007
New	2-story sfr w/attached garage				2007
New	Two-story residence with attached garage				2007
New	SENT PERMIT FOLDER TO RECORDS ROOM 12/01/08 DM Two-story residence with attached ga				2007
New	Two story SFR with attached Garage				2007
New	Rambler with attached garage				2007
New	SENT PERMIT FOLDER TO RECORDS ROOM 12/01/08 DM 2 Story SFR w/ attached garage				2007
New	Two-story residence with attached garage				2007
New	2-Story SFR w/attached garage.				2007
New	2-story sfr w/attached garage				2007
New	2-story sfr w/attached garage				2007
New	15 ft x 38 ft 2 story SFR				2007
New	2-story sfr w/attached garage				2007
New	Proposed 2535 sq ft single family residence with 785 sq ft attached garage.				2007
New	Two story SFR with attached Garage				2007
New	SENT PERMIT FOLDER TO RECORDS ROOM 12/01/08 DM 2-story sfr w/attached garage				2007
New	2 story sfr w/attached garage				2007
New	2-Story SFR w/attached garage				2007
New	Approved basic 07-101900 BP	2003 IRC	Plan# 2929	2-story sfr w/attached garage	2007
New	SENT PERMIT FOLDER TO RECORDS ROOM 10/23/08 DM Two-story SFR with unfinished basem				2007
New	Approved basic 07-101900 BP	2003 IRC	Plan# 2929	2-story sfr w/attached garage	2007
New	2-story, 4 bedroom, home with attached 3-car garage.				2007
New	SENT PERMIT FOLDER TO RECORDS ROOM 11/24/08 DM 2003 IRC - 2-Story SFR w/ attache				2007
New	SENT PERMIT FOLDER TO RECORDS ROOM 11/24/08 DM 2003 IRC - 2-Story SFR w/ attached				2007
New	SENT PERMIT FOLDER TO RECORDS ROOM 11/24/08 DM 2003 IRC - 2-Story SFR w/ attache				2007
New	2003 IRC - 2-Story SFR w/ attached garage				2007

Accessory Dwelling Units

Index # - File Name: 1.0022 - Single Family Dwellings Data\_Snohomish County.pdf

New	2003 IRC	-	2-Story SFR w/ attached garage	2007
New	2003 IRC	-	2-Story SFR w/ attached garage	2007
New	41 ft x 50 ft	two story SFR with daylight basement & attached garage		2007
New	SENT PERMIT FOLDER TO RECORDS ROOM 11/24/08 DM Approved Basic 04-115896BP			2007
New	SENT PERMIT FOLDER TO RECORDS ROOM 11/24/08 DM	2003 IRC	2-Story SFR w/ attache	2007
New	SENT PERMIT FOLDER TO RECORDS ROOM 11/24/08 DM	2003 IRC	2-Story SFR w/ attache	2007
New	SENT PERMIT FOLDER TO RECORDS ROOM 11/24/08 DM	Two-story SFR with attached garage a		2007
New	1767 sq ft Rambler			2007
New	SENT PERMIT FOLDER TO RECORDS ROOM 11/21/08 DM	3207 sq fat Rambler with attached Ga		2007
New	2-story w/garage 2003 IRC			2007
New	Approved Basic 06-127259BP	2003IRC	Two-story SFR with attached garage Plan: 21	2007
New	Approved Basic 07-105270-BP	2006 IRC	Bldr. Plan # 2486 2-Story SFR w/ attached garage	2007
New	SENT PERMIT FOLDER TO RECORDS ROOM 12/01/08 DM Approved basic 06-134566 BP 200			2007
New	Approved Basic 07-10362 BP	2006 IRC	Plan: 2486G 2-story home w/ attached 2 car gara	2007
New	Approved basic 06-134566 BP	2003 IRC	Plan# 2267 2-story sfr w/attached garage	2007
New	Approved Basic 07-10364 BP	2006 IRC	Plan: 2160G 2-story home w/ attached 2 car gara	2007
New	Approved Basic 07-10364 BP	2006 IRC	Plan: 2160G 2-story home w/ attached 2 car gara	2007
New	Permit transfered from PDR to Family Pryde Homes LLC docs sent to film. 04-07-09 jrind SENT			2007
New	Two-story SFR with semi-finished basement			2007
New	Approved Basic 04-119145BP		Plan 1786 Two-story SFR with attached	2007
New	Approved Basic 05- 123059BP	2003 IRC	Plan: 2160 Two-story SFR w	2007
New	Approved basic 06-134566 BP	2003 IRC	Plan# 2267 2-story sfr w/attached garage	2007
New	Approved basic 06-134566 BP	2003 IRC	Plan# 2267 2-story sfr w/attached garage	2007
New	Approved basic 06-134566 BP	2003 IRC	Plan# 2267 2-story sfr w/attached garage	2007
New	Approved Basic 07-105270-BP	2006 IRC	Bldr. Plan # 2486 2 Story SFR w/ attached garage	2007
New	Approved basic 06-134566 BP	2003 IRC	Plan# 2267 2-story sfr w/attached garage	2007
New	Approved Basic 07-106477 BP	2006 IRC	Plan: 2002 2-story residence with attached ga	2007
New	Approved basic 07-109644 BP	2006 IRC	Plan# 2968 2-story sfr w/attached garage w/ bon	2007
New	Approved Basic 04-115826BP	2 story SFR w/attached garage	2003 IRC Plan:2783	2007
New	1922 sq ft single family residence with 438 sq ft attached garage.			2007
New	2 story w/ finished basement & attached 2 car garage			2007
New	RSD to SHD 3/28/2007 TLilly Two story SFR with attached Garage			2007
New	Approved Basic 07-100630 BP	2003 IRC	Plan: 145-2 Rambler w/ attached 2 car garage	2007
New	SFR with attached garage			2007
New	Approved Basic #05-126875 BP	2003 IRC	2 story SFR w/attached garage Plan: Ashford	2007
New	Approved Basic #05-118962 BP	2003 IRC	2 story SFR w/attached garage Plan:M2625A3	2007
New	Approved 07-110198-BP	2006 IRC	Plan # M2605A35-2 2-Story SFR w/ attached	2007
New	New 2 story SFR w/ unfinished basement and attached garage			2007
New	Two-story residence with attached garage			2007
New	32 ft x 64 ft SFR			2007
New	Rambler style SFR w/attached garage			2007
New	62 ft x 67 ft SFR with attached garage			2007
New	Approved basic 06-137167 BP	2003 IRC	Plan# Glenbrook 2-story sfr w/attached ga	2007
New	Approved Basic # 06-136132 BP -	2003 IRC	Two story SFR with attached Garage Plan: Bridge	2007
New	Approved Basic 06-136125 BP -	2003 IRC	Two story SFR with attached Garage Plan: Summe	2007
New	Approved basic 06-137167 BP	2003 IRC	Plan# Glenbrook 2-story sfr w/attached ga	2007
New	Approved Basic 06-136133 BP	2003 IRC	Two story SFR with attached Garage Plan: Brennan	2007

Accessory Dwelling Units

Index # - File Name: 1.0022 - Single Family Dwellings Data\_Snohomish County.pdf

New	Approved Basic 06-136125 BP - 2003 IRC	Two story SFR with attached Garage	Plan: Summer	2007
New	Approved Basic 06-136125 BP - 2003 IRC	Two story SFR with attached Garage	Plan: Summer	2007
New	Approved Basic # 06-136132 BP - 2003 IRC	Two story SFR with attached Garage	Plan: Bridge	2007
New	Approved Basic 06-136130 BP 2003 IRC	Two story SFR with attached Garage	Plan: Hampto	2007
New	Approved basic 06-137167 BP 2003 IRC	Plan# Glenbrook 2-story sfr w/attached ga		2007
New	Approved Basic 06-136135 BP - 2003 IRC	Two story SFR with attached Garage	Plan: Elliston	2007
New	SENT PERMIT FOLDER TO RECORDS ROOM 11/21/08 DM	New SFR two story w/ attached car-pc		2007
New	SENT PERMIT FOLDER TO RECORDS ROOM 11/26/08 DM	2007 Karsten Mobile Home		2007
New	Rambler with Attached Garage			2007
New	Proposed 2-story single family residence.			2007
New	Approved Basic 07-100629 BP 2003 IRC	Plan: 2352 FC (B) Two Story SFR with attched Ga		2007
New	Approved Basic 07-100629 BP 2003 IRC	Plan: 2352 FC (B) Two Story SFR with attched Ga		2007
New	SENT PERMIT FOLDER TO RECORDS ROOM 11/24/08 DM	Approved Basic 07-100629 BP 200		2007
New	Approved Basic 06-136130 BP 2003 IRC	Two story SFR with attached Garage	Plan: Hampto	2007
New	2 story, four bedroom home with attached 3 car garage			2007
New	SENT PERMIT FOLDER TO RECORDS ROOM 11/24/08 DM	2 story, three bedroom home with off		2007
New	SENT PERMIT FOLDER TO RECORDS ROOM 10/27/08 DM	Approved Basic 05-116276BP		2007
New	New two story SFR w/ attached garage			2007
New	SENT PERMIT FOLDER TO RECORDS ROOM 11/26/08 DM	two story w/finished basement and ga		2007
New	SENT PERMIT FOLDER TO RECORDS ROOM 11/24/08 DM	New SFR 2 story w/ attached garage		2007
New	SENT PERMIT FOLDER TO RECORDS ROOM 11/24/08 DM	New SFR - 2 stroy w/ attached garage		2007
New	2-Story Single Family Residence with attached garage.			2007
New	Approved Basic 07-101621-BP 2003 IRC	Plan # 1858A 2-story sfr w/ attached gar		2007
New	2 story SFR w/ attached garage			2007
New	Approved Basic 07-101624-BP 2003 IRC	Plan #1935A 2-story sfr w/ attached gara		2007
New	Approved Basic 07-101625-BP 2003 IRC	Plan #1935B 2-story sfr w/ attached g		2007
New	Approved Basic 07-101620-BP 2003 IRC	Plan # 1825B 2-story sfr w/ attached		2007
New	SENT PERMIT FOLDER TO RECORDS ROOM 12/01/08 DM	Approved Basic 07-101619-BP 2		2007
New	SENT PERMIT FOLDER TO RECORDS ROOM 12/01/08 DM	Approved Basic 07-101620-BP 2		2007
New	Approved Basic 07-101625-BP 2003 IRC	Plan #1935B 2-story sfr w/ attached g		2007
New	Approved Basic 07-101619-BP 2003 IRC	Plan #1825A 2-story sfr w/ attached		2007
New	Approved Basic 07-101624-BP 2003 IRC	Plan #1935A 2-story sfr w/ attached gara		2007
New	Approved Basic 07-101624-BP 2003 IRC	Plan #1935A 2-story sfr w/ attached gara		2007
New	Approved Basic 07-101616-BP 2003 IRC	Plan # 1507C 2-story sfr w/ attached gara		2007
New	Approved Basic 07-101615-BP 2003 IRC	Plan # 1507B 2-story sfr w/ attached gara		2007
New	Approved Basic 07-101612-BP 2003 IRC	Plan #1507A 2-story sfr w/ attache		2007
New	Approved Basic 07-101621-BP 2003 IRC	Plan # 1858A 2-story sfr w/ attached gar		2007
New	Approved basic 06-129078 BP 2003 IRC	Plan# 2838 2 story with attached 3 car gara		2007
New	2-story w/garage			2007
New	Approved Basic 07-101619-BP 2003 IRC	Plan #1825A 2-story sfr w/ attached		2007
New	Approved Basic 07-101622-BP 2003 IRC	Plan # 1858B 2-story sfr w/ attached gara		2007
New	d_rpt_inspection_card Approved Basic #07-107306 BP	2006 IRC Plan B-2781 Two Story SF		2007
New	New 2 Story SFR w/ attachced garage			2007
New	2-story w/garage			2007
New	2-story SFR w/ garage			2007
New	Approved Basic 07-104797-BP 2003 IRC	Plan # Master Down 2718 2-story sfr v		2007
New	Approved Basic: 07-104797-BP 2003 IRC - Contractor s #:	Master Down 2718 - Two Story SFR		2007

Accessory Dwelling Units

Index # - File Name: 1.0022 - Single Family Dwellings Data\_Snohomish County.pdf

New	Approved basic 07-102338 BP	2003 IRC	Plan# 2780	2-story sfr w/attached garage	2007
New	Approved basic 07-102336 BP	2003 IRC	Plan# 2520	2-story sfr w/attached	2007
New	Approved basic 07-102338 BP	2003 IRC	Plan# 2780	2-story sfr w/attached garage	2007
New	Approved basic 07-102336 BP	2003 IRC	Plan# 2520	2-story sfr w/attached	2007
New	Approved Basic #07-107306 BP	2006 IRC	Plan B-2781	Two Story SFR w/attached garage	2007
New	*Issued under tax roll 003730-021-011-02*	Approved Basic # 04-114427BP	Plan: 50080-		2007
New	*Issued under tax roll 003730-021-011-02*	Approved Basic # 04-115134BP	2 story SFR w/atta		2007
New	*Issued under tax roll 003730-021-011-02*	Approved Basic #04-114800BP	Plan: 40020-A2		2007
New	*Issued under tax roll 003730-021-011-02*	Approved basic 05-129117 BP	2003 IRC	Plan #	2007
New	*Issued under tax roll 003730-021-011-02*	Approved Basic 04-115134 BP	2 story SFR w/attac		2007
New	*Issued under tax roll 003730-021-011-02*	Approved Basic 04-114427 BP	Plan: 50080-A3		2007
New	*Issued under tax roll 003730-021-011-02*	Approved basic 05-129117 BP	2003 IRC	Plan #	2007
New	*Issued under tax roll 003730-021-011-02*	Approved Basic 04-114800 BP	Plan: 40020-A2	T	2007
New	SENT PERMIT FOLDER TO RECORDS ROOM 11/24/08 DM			Two story SFR with finished Basement	2007
New	SENT PERMIT FOLDER TO RECORDS ROOM 12/01/08 DM			2-story SFR w/garage	2007
New	New SFR - 2 story split level w/ attached garage				2007
New	Two-story residence with attached garage				2007
New	Approved Basic 06-100083BP	2003 IRC	2 story SFR w/attached garage	Plan:21:	2007
New	Approved Basic # 07-101197 BP	2003 IRC	Plan 2747	Two story SFR with attached Gar	2007
New	Approved basic 06-126631 BP	2003 IRC	Plan# 2278 Alt	2-story sfr w/attached gara	2007
New	Approved Basic 04-120167BP	2 story SFR w/attached garage	2003 IRC	Plan:2597	2007
New	Approved Basic # 07-101197 BP	2003 IRC	Plan 2747	Two story SFR with attached Gar	2007
New	SENT PERMIT FOLDER TO RECORDS ROOM 12/01/08 DM	Approved Basic 05-125233BP	2 :		2007
New	SENT PERMIT FOLDER TO RECORDS ROOM 12/01/08 DM	Approved basic #05-117623			2007
New	SENT PERMIT FOLDER TO RECORDS ROOM 12/01/08 DM	Approved Basic 05-123477 BP	200		2007
New	SENT PERMIT FOLDER TO RECORDS ROOM 12/01/08 DM	Rambler style w/garage			2007
New	New single story w/ attached garage				2007
New	2006 sq ft Rambler with attached Garage				2007
New	Two story SFR with attached Garage				2007
New	Two story SFR with attached Garage				2007
New	Rambler with attached garage				2007
New	Approved Basic # 07-101943 BP	2003 IRC	Plan: 3514	Two story SFR with attached C	2007
New	2-story sfr w/attached garage				2007
New	SENT PERMIT FOLDER TO RECORDS ROOM 12/01/08 DM	2902 SF rambler with attached garage			2007
New	2006 sq ft Rambler with attached Garage				2007
New	Rambler Style SFR w/attached garage.				2007
New	SENT PERMIT FOLDER TO RECORDS ROOM 11/26/08 DM	Rambler style w/garage			2007
New	2-story SFR w/garage				2007
New	2 story SFR w/ attachced garage				2007
New	2-story SFR w/attached garage.				2007
New	Two-story residence with attached garage				2007
New	Two-story residence with attached garage				2007
New	Two-story residence with attached garage				2007
New	SENT PERMIT FOLDER TO RECORDS ROOM 12/01/08 DM	Approved Basic # 07-1109743 BP	200		2007
New	Two Story SFR with Attached Garage	2003 IRC			2007
New	Two story SFR w/ attached garage				2007
New	Two Story SFR with Attached Garage	2003 IRC			2007

Accessory Dwelling Units

Index # - File Name: 1.0022 - Single Family Dwellings Data\_Snohomish County.pdf

New	Approved basic 05-117681 BP	2003 IRC	Plan# Lopez	2 story sfr w/attached garage	2007
New	Two-story residence with attached garage				2007
New	SENT PERMIT FOLDER TO RECORDS ROOM 11/24/08 DMwo story SFR with attached Garage				2007
New	Approved Basic 04-117012BP	2003 IRC	Plan:2111A	2 story SFR w/attached garage	2007
New	Approved Basic 07-112335-BP	2006 IRC	Plan No 2431 B	2 story SFR w/ attached 2 or 3	2007
New	Approved Basic 05-117923BP	2003 IRC	Plan:2585A	2 story SFR w/attached gara	2007
New	Approved Basic 05-124092BP	2003 IRC	Plan:2511 A & C	2 story SFR w/attached garage	2007
New	Approved basic 07-100997 BP	2003 IRC	Plan# 1711 B	2-story sfr w/attached ga	2007
New	Approved Basic 04-120594BP	2003 IRC	Plan:2011A	2 story SFR w/attached garage	2007
New	Approved Basic 05- 1000527BP				2007
New	Approved basic 07-112903 BP	2006 IRC	Plan# 2131 A	2-story sfr w/attached gar	2007
New	Approved Basic 07-113302-BP	2006 IRC	Plan No. 2401 A	2 story SFR w/ attached g	2007
New	Approved Basic 07-109651-BP	2006 IRC / WSEC	Builder No. 2343 A	2 story SFR with	2007
New	Approved Basic 07-109672-BP	2006 IRC / WSEC	Builder No. 1531 A	2 story SFR w/ attach	2007
New	Approved Basic 07-113570-BP	2006 IRC	Plan No 2201 A	2 story SFR w/ attached garag	2007
New	Approved Basic 07-109129-BP	2006 IRC	Plan # 1711 A	2- Story SFR w/ attached g	2007
New	Approved Basic 06-134965 BP	2003 IRC	Plan# 1613 A	Rambler style SFR w/attached garage	2007
New	Approved Basic 05-126842BP	2003 IRC	Plan:2521A & C	2 story SFR w/attached garage	2007
New	Approved Basic 05-117083BP	2003 IRC	Plan:2021C	2 story SFR w/attached garage	2007
New	Approved Basic 06-133265BP -	2003 IRC	Plan: 2411 A	Two-story SFR with attached garage	2007
New	Approved Basic 07-100831BP	2003 IRC	Plan: 1511C	Two-story SFR with attached garage	2007
New	Approved Basic 04-120594BP	2003 IRC	Plan:2011A	2 story SFR w/attached garage	2007
New	Approved Basic 05-120481BP	2003 IRC	Plan:2131	2 story SFR w/attached garage	2007
New	Approved Basic 05- 1000527BP				2007
New	Approved Basic 05-100758BP	2003 IRC	Plan:2021A		2007
New	Approved Basic 07-113303-BP	2006 IRC	Plan No. 2401 B	2 story SFR w/ attached gar:	2007
New	Approved Basic 07-114391-BP	2006 IRC	Plan No 2811 C	2 story SFR w/ attached garage	2007
New	Approved basic 06-126631 BP	2003 IRC	Plan# 2278 Alt	2-story sfr w/attached gara	2007
New	Approved Basic 04-118845BP	2003 IRC	Plan:2294	2 story SFR w/attached garage	2007
New	SENT PERMIT FOLDER TO RECORDS ROOM 11/18/08 DM Approved Basic 04-118845BP 2 stor				2007
New					2007
New	2710 sq ft SFR with 402 sq ft attached garage				2007
New	Approved Basic #07-101228 BP	2003 IRC		Rambler style w/semi-finished basement & garage	2007
New	2742 sq ft single family residence with atached 640 sq ft garage.				2007
New	2 story SFR w/ attached garage				2007
New	EXPIRED WITHOUT COUNTY APPROVAL TO USE OR OCCUPY 5/12/09 DM Approved Basic 06-10				2007
New	Approved basic 06-126631 BP	2003 IRC	Plan# 2278 Alt	2-story sfr w/attached gara	2007
New	SENT PERMIT FOLDER TO RECORDS ROOM 10/28/08 DM Approved Basic 06-135938-BP 20				2007
New	SENT PERMIT FOLDER TO RECORDS ROOM 11/21/08 DM Approved basic 06-126631 BP 20				2007
New	SENT PERMIT FOLDER TO RECORDS ROOM 11/18/08 DM Approved Basic 06-135938-BP 20				2007
New	Approved basic 06-126631 BP	2003 IRC	Plan# 2278 Alt	2-story sfr w/attached gara	2007
New	2-story SFR w/garage				2007
New	44 ft x 60 ft two story SFR with attached garage				2007
New	64 x 62 two story SFR				2007
New	SENT PERMIT FOLDER TO RECORDS ROOM 11/18/08 DM Approved Basic 04-120167BP 2 story				2007
New	Approved Basic 07-104082-BP	2003 IRC	Plan # 2463 Alt	2-Story SFR w/ attached garage	2007
New	Approved Basic 06-135660-BP	2003 IRC	Plan# 1804	2-Story SFR w/attached garage.	2007

Accessory Dwelling Units

Index # - File Name: 1.0022 - Single Family Dwellings Data\_Snohomish County.pdf

New	Approved Basic 06-135659-BP	2003 IRC	Builder Plan# 2115	2-Story S	2007
New	Two-story residence with attached garage				2007
New	Two-story residence with attached garage				2007
New	Approved Basic 06-135659-BP	2003 IRC	Builder Plan# 2115	2-Story SFR w/attached ga	2007
New	New 2 story SFR w/ attached garage				2007
New	New two story SFR w/ attached garage				2007
New	SENT PERMIT FOLDER TO RECORDS ROOM 11/24/08 DM	Approved Basic 06-135659-BP	2003		2007
New	SENT PERMIT FOLDER TO RECORDS ROOM 11/24/08 DM	Approved Basic 06-135660-BP	2003		2007
New	Approved Basic 06-135659-BP	2003 IRC	Builder Plan# 2115	2-Story SFR w/attached ga	2007
New	Approved Basic 06-135660-BP	2003 IRC	Plan# 1804	2-Story SFR w/attached garage.	2007
New	Two story SFR with attached Garage				2007
New	Approved basic 05-126159 BP	2003 IRC	Plan# 3036 A	2-story sfr w/attache	2007
New	Approved basic 05-126157 BP	2003 IRC	Plan# 2700 B	2-story sfr w/attached g	2007
New	Approved basic 05-126160 BP	2003 IRC	Plan# 3036 B	2-story sfr w/attached ga	2007
New	Approved Basic 06-132059BP	2003 IRC	Two-story SFR with attached garage	Plan: T2472-02A-	2007
New	Approved basic 05-126159 BP	2003IRC	Plan# 3036 A	2-story sfr w/attached g	2007
New	Approved basic 05-128452 BP	2003 IRC	Plan# 2440 BE	2-story sfr w/attached gar	2007
New	Approved basic 05-126160 BP	2003 IRC	Plan# 3036 B	2-story sfr w/attached ga	2007
New	Approved Basic 06-132059BP	2003 IRC	Two-story SFR with attached garage	Plan: T2472-02A-	2007
New	SENT PERMIT FOLDER TO RECORDS ROOM 11/21/08 DM	Approved basic 06-132143 BP	2003		2007
New	Approved basic 06-132142 BP	2003 IRC	Plan# 2100	2-story sfr w/attached garag	2007
New	Approved basic 05-125813 BP	2003 IRC	Plan# 4	2-story sfr w/attached garag	2007
New	Approved basic 05-125813 BP	2003 IRC	Plan# 4	2-story sfr w/attached garag	2007
New	Approved basic 05-125817 BP	2003 IRC	Plan# 5	2-story sfr w/attached	2007
New	Approved 05-125814 BP	2003 IRC	Plan # 1	2-story sfr w/attached garage	2007
New	Approved basic 05-125817 BP	2003 IRC	Plan# 5	2-story sfr w/attached	2007
New	Approved 05-125815 BP	2003 IRC	Plan # 3	2-story sfr w/attached gara	2007
New	Approved basic 05-125813 BP	2003 IRC	Plan# 4	2-story sfr w/attached garag	2007
New	SENT PERMIT FOLDER TO RECORDS ROOM 12/01/08 DM	Approved Basic 07-108874-BP	Buili		2007
New	Approved Basic 07-112553-BP	2006 IRC	Plan # 1592	2- Story SFR w/ attached	2007
New	Approved Basic 07-112553-BP	2006 IRC	Plan # 1592	2- Story SFR w/ attached	2007
New	Pending Basic 07-112553-BP	2006 IRC	Plan # 1592	2- Story SFR w/ attached ga	2007
New	Approved Basic 07-112553-BP	2006 IRC	Plan # 1592	2- Story SFR w/ attached	2007
New	Approved basic 05-125817 BP	2003 IRC	Plan# 5	2-story sfr w/attached	2007
New	Approved basic 05-125812 BP	2003 IRC	Plan# 2	2-story sfr w/attached g	2007
New	SENT PERMIT FOLDER TO RECORDS ROOM 11/26/08 DM	Approved basic 05-125813 BP	2003		2007
New	Approved 05-125814 BP	2003 IRC	Plan # 1	2-story sfr w/attached garage	2007
New	Approved basic 05-125817 BP	2003 IRC	Plan# 5	2-story sfr w/attached	2007
New	SENT PERMIT FOLDER TO RECORDS ROOM 11/26/08 DM	THIS BASIC CAN ONLY BE USED IN A Z			2007
New	Approved basic 06-132144 BP	2003 IRC	Plan# 2838	2-story sfr w/attached garag	2007
New	Approved basic 06-132143 BP	2003 IRC	Plan # 2482	2-story sfr w/attached garage	2007
New	Approved basic 06-132144 BP	2003 IRC	Plan# 2838	2-story sfr w/attached garag	2007
New	Approved basic 06-135098 BP	2003 IRC	Plan #2680 Woodcress	Two story SFR with atta	2007
New	Approved basic 06-132163 BP	2003 IRC	Plan# 2680	2-story sfr w/attached garag	2007
New	Approved basic 06-132143 BP	2003 IRC	Plan # 2482	2-story sfr w/attached garage	2007
New	Approved basic 06-132142 BP	2003 IRC	Plan# 2100	2-story sfr w/attached garag	2007
New	Approved basic 06-132144 BP	2003 IRC	Plan# 2838	2-story sfr w/attached garag	2007



Accessory Dwelling Units

Index # - File Name: 1.0022 - Single Family Dwellings Data\_Snohomish County.pdf

New	Approved basic 06-132143 BP	2003 IRC	Plan # 2482	2-story sfr w/attached garage	2007
New	Approved basic 06-132144 BP	2003 IRC	Plan# 2838	2-story sfr w/attached garage	2007
New	SENT PERMIT FOLDER TO RECORDS ROOM 11/21/08 DM 2 story w/covered entry				2007
New	Approved basic 06-135098 BP	2003 IRC	Plan #2680 Woodcress	Two story SFR with attached garage	2007
New	Approved basic 06-135098 BP	2003 IRC	Plan #2680 Woodcress	Two story SFR with attached garage	2007
New	Approved basic 06-133571 BP	2003 IRC	Plan# 2658 A	2-story sfr w/attached garage	2007
New	Approved basic 06-129262 BP	2003 IRC	Plan# 3016 B	2-story sfr w/attached garage	2007
New	Approved basic 06-124918 BP	2003 IRC	Plan 2996 A	2-story sfr w/attached garage	2007
New	Approved basic 06-124919 BP	2003 IRC	Plan 3271 B	2-story sfr w/attached garage	2007
New	Approved basic 06-124917 BP	2003 IRC	Plan 3200 A	2-story sfr w/attached garage	2007
New	Approved basic 06-124918 BP	2003 IRC	Plan 2996 A	2-story sfr w/attached garage	2007
New	Approved basic 06-135098 BP	2003 IRC	Plan #2680 Woodcress	Two story SFR with attached garage	2007
New	Approved basic 06-132143 BP	2003 IRC	Plan # 2482	2-story sfr w/attached garage	2007
New	Approved basic 06-135098 BP	2003 IRC	Plan #2680 Woodcress	Two story SFR with attached garage	2007
New	SENT PERMIT FOLDER TO RECORDS ROOM 12/01/08 DM Approved basic 07-109475 BP				2007
New	Approved basic 06-135098 BP	2003 IRC	Plan #2680 Woodcress	Two story SFR with attached garage	2007
New	SENT PERMIT FOLDER TO RECORDS ROOM 11/24/08 DM Approved basic 06-132143 BP				2007
New	Approved basic 07-109473 BP	2006 IRC	Plan# 2680	2-story sfr w/attached garage	2007
New	Approved basic 06-132144 BP	2003 IRC	Plan# 2838	2-story sfr w/attached garage	2007
New	Approved basic 06-135098 BP	2003 IRC	Plan #2680 Woodcress	Two story SFR with attached garage	2007
New	SENT PERMIT FOLDER TO RECORDS ROOM 12/01/08 DM 2 story SFR w/ attached garage				2007
New	Approved Basic 06-136074 BP	2003 IRC	Two Story SFR with attached Garage	Plan: 2340 FC	2007
New	Approved Basic 07-100629 BP	2003 IRC	Plan: 2352 FC (B)	Two Story SFR with attached Garage	2007
New	Approved basic 06-132647 BP	2003 IRC	Plan# 2352 FC	2-story sfr w/attached garage	2007
New	Approved basic 06-132647 BP	2003 IRC	Plan# 2352 FC	2-story sfr w/attached garage	2007
New	Approved Basic 07-100629 BP	2003 IRC	Plan: 2352 FC (B)	Two Story SFR with attached Garage	2007
New	Approved Basic # 07-100627 BP	2003 IRC	Plan: 2562 FC	Two story SFR with attached garage	2007
New	2-story w/garage				2007
New	Two-story residence with attached garage				2007
New	Approved basic 06-124918 BP	2003 IRC	Plan 2996 A	2-story sfr w/attached garage	2007
New	SENT PERMIT FOLDER TO RECORDS ROOM 12/01/08 DM 2 story SFR w/ attached garage and 2nd floor				2007
New	Approved Basic 06-136074 BP	2003 IRC	Two Story SFR with attached Garage	Plan: 2340 FC	2007
New	Approved basic 06-133571 BP	2003 IRC	Plan# 2658 A	2-story sfr w/attached garage	2007
New	Approved basic 06-133572 BP	2003 IRC	Plan# 2658 B	2-story sfr w/attached garage	2007
New	Approved basic 06-133571 BP	2003 IRC	Plan# 2658 A	2-story sfr w/attached garage	2007
New	Approved basic 06-133572 BP	2003 IRC	Plan# 2658 B	2-story sfr w/attached garage	2007
New	Approved basic 06-133571 BP	2003 IRC	Plan# 2658 A	2-story sfr w/attached garage	2007
New	Approved basic 06-129262 BP	2003 IRC	Plan# 3016 B	2-story sfr w/attached garage	2007
New	Approved basic 06-133571 BP	2003 IRC	Plan# 2658 A	2-story sfr w/attached garage	2007
New	Approved basic 06-129261 BP	2003 IRC	Plan 3016 A	2-story sfr w/attached garage	2007
New	Approved Basic 06-129276 BP	2003 IRC	Plan: 2840	Two-story home with attached 2 car garage	2007
New	Approved Basic 06-129275 BP	2003 IRC	Plan: 3005	2-story sfr w/attached garage	2007
New	Approved Basic 06-129276 BP	2003 IRC	Plan: 2840	Two-story home with attached 2 car garage	2007
New	Approved Basic 06-129275 BP	2003 IRC	Plan: 3005	2-story sfr w/attached garage	2007
New	Approved Basic 06-129277 BP	2003 IRC	Plan 2805	2-story sfr w/attached garage	2007
New	Approved Basic 06-129276 BP	2003 IRC	Plan: 2840	Two-story home with attached 2 car garage	2007
New	Approved Basic 06-129275 BP	2003 IRC	Plan: 3005	2-story sfr w/attached garage	2007

Accessory Dwelling Units

Index # - File Name: 1.0022 - Single Family Dwellings Data\_Snohomish County.pdf

New	Approved Basic 06-129275 BP	2003 IRC	Plan: 3005	2-story sfr w/attached garage	2007
New	2-Story SFR w/ attached 3 car garage	2006 IBC			2007
New	Single family residence w/attached garage	2006 IBC			2007
New	Approved basic 07-105280 BP	2006 IRC	Plan# 1493	Rambler w/attached garage	2007
New	Approved basic 07-105279 BP	2006 IRC	Plan# 1865	2-story sfr w/attached garage	2007
New	Approved basic 07-105281 BP	2006 IRC	Plan# 2189	2-story sfr w/attached garage	2007
New	2 Story SFR with attached 3 car garage.	2006 IBC			2007
New	Approved basic 07-105281 BP	2006 IRC	Plan# 2189	2-story sfr w/attached garage	2007
New	Approved basic 07-105280 BP	2006 IRC	Plan# 1493	Rambler w/attached garage	2007
New	Approved basic #07-105279 BP	2006 IRC	Plan# 1865	2-story sfr w/attached garage	2007
New	Approved basic 07-105280 BP	2006 IRC	Plan# 1493	Rambler w/attached garage	2007
New	Approved basic 07-105280 BP	2006 IRC	Plan# 1493	Rambler w/attached garage	2007
New	Approved basic 07-105280 BP	2006 IRC	Plan# 1493	Rambler w/attached garage	2007
New	EXPIRED WITHOUT COUNTY APPROVAL TO USE OR OCCUPY 9/16/09 DM SENT PERMIT FOLDER				2007
New	Approved basic 07-105280 BP	2006 IRC	Plan# 1493	Rambler w/attached garage	2007
New	Approved Basic 07-105280BP	Builder No. 149	2006 IRC	2 story SFR w/ attached garage	2007
New	SENT PERMIT FOLDER TO RECORDS ROOM 12/01/08 DM	Approved Basic 07-105281-BP	Build		2007
New	Approved basic 07-105280 BP	2006 IRC	Plan# 1493	Rambler w/attached garage	2007
New	Approved basic 07-105280 BP	2006 IRC	Plan# 1493	Rambler w/attached garage	2007
New	Approved Basic 07-109698-BP	Builder No. 2189-B	2006 IRC	2 story SFR w/ attached 2 or 3 car	2007
New	Approved basic 07-105280 BP	2006 IRC	Plan# 1493	Rambler w/attached garage	2007
New	SENT PERMIT FOLDER TO RECORDS ROOM 11/26/08 DM	Approved basic 07-105279 BP	2006 IRC		2007
New	Approved basic 07-105280 BP	2006 IRC	Plan# 1493	Rambler w/attached garage	2007
New	Approved basic 07-105280 BP	2006 IRC	Plan# 1493	Rambler w/attached garage	2007
New	Two-story sfr with attached garage				2007
New	2-story w/unfinished basement and garage				2007
New	*Issued under tax roll # 270516-002-005-00*	Approved Basic 05-128622BP	2003 IRC	2 s	2007
New	*Issued under tax roll # 270516-002-005-00*	Approved Basic 06-101697BP	2003 IRC	2 s	2007
New	*Issued under tax roll # 270516-002-005-00*	Approved Basic 06-101697BP	2003 IRC	2 s	2007
New	*Issued under tax roll # 270516-002-005-00*	Approved basic 06-125104 BP	2003 IRC		2007
New	*Issued under tax roll # 270516-002-005-00*	Approved Basic 06-101697BP	2003 IRC	2 s	2007
New	*Issued under tax roll # 270516-002-005-00*	Approved Basic 05-128622BP	2003 IRC	2 s	2007
New	*Issued under tax roll # 270516-002-005-00*	Approved Basic 05-128622BP	2003 IRC	2 s	2007
New	SENT PERMIT FOLDER TO RECORDS ROOM 11/24/08 DM	*Issued under tax roll # 270516-002-005-00*			2007
New	Approved Basic 06-102497BP	2003 IRC	2 story SFR w/attached garage	Plan:Sloane TH	2007
New	Approved Basic 06-102494BP	2003 IRC	2 story SFR w/attached garage	Plan:Montag	2007
New	Approved Basic 06-102495BP	2003 IRC	2 story SFR w/attached garage	Plan:Soho	2007
New	SENT PERMIT FOLDER TO RECORDS ROOM 11/26/08 DM	*Issued under tax roll # 270516-002-005-00*			2007
New	SENT PERMIT FOLDER TO RECORDS ROOM 11/26/08 DM	*Issued under tax roll # 270516-002-005-00*			2007
New	SENT PERMIT FOLDER TO RECORDS ROOM 11/26/08 DM	*Issued under tax roll # 270516-002-005-00*			2007
New	SENT PERMIT FOLDER TO RECORDS ROOM 11/26/08 DM	*Issued under tax roll # 270516-002-005-00*			2007
New	*Issued under tax roll # 270516-002-005-00*	Approved Basic 05-128838BP	2003 IRC		2007
New	SENT PERMIT FOLDER TO RECORDS ROOM 11/26/08 DM	*Issued under tax roll # 270516-002-005-00*			2007
New	SENT PERMIT FOLDER TO RECORDS ROOM 11/26/08 DM	*Issued under tax roll # 270516-002-005-00*			2007
New	*Issued under tax roll # 270516-002-005-00*	Approved basic 06-125104 BP	2003 IRC		2007
New	*Issued under tax roll # 270516-002-005-00*	Approved basic 06-125104 BP	2003 IRC		2007
New	*Issued under tax roll # 270516-002-005-00*	Approved basic 06-125104 BP	2003 IRC		2007

Accessory Dwelling Units

Index # - File Name: 1.0022 - Single Family Dwellings Data\_Snohomish County.pdf

New	*Issued under tax roll # 270516-002-005-00*	Approved Basic 06-101697BP	2003 IRC	2	2007
New	*Issued under tax roll # 270516-002-005-00*	Approved Basic 05-128622BP	2003 IRC	2 s	2007
New	*Issued under tax roll # 270516-002-005-00*	Approved basic 06-125104 BP	2003 IRC		2007
New	*Issued under tax roll # 270516-002-005-00*	Approved Basic 05-128625	2003 IRC	2 stor	2007
New	Approved Basic 06-102497BP	2003 IRC	2 story SFR w/attached garage	Plan:Sloane *o	2007
New	Approved Basic 06-102495BP	2003 IRC	2 story SFR w/attached garage	Plan:Soho	2007
New	Approved Basic 06-102497BP	2003 IRC	2 story SFR w/attached garage	Plan:Sloane	2007
New	Approved Basic 05-122739BP	2003 IRC	3 story SFR w/attached garage	Plan:Preston	2007
New	Approved Basic 06-102491BP	2003 IRC	2 story SFR w/attached garage	Plan:Cadago	2007
New	Approved Basic 06-102495BP	2003 IRC	2 story SFR w/attached garage	Plan:Soho	2007
New	Approved Basic 05-122739BP	2003 IRC	3 story SFR w/attached garage	Plan:Preston	2007
New	Approved Basic 06-102494BP	2003 IRC	2 story SFR w/attached garage	Plan:Montag	2007
New	Approved Basic 06-102495BP	2003 IRC	2 story SFR w/attached garage	Plan:Soho	2007
New	Approved Basic 06-102497BP	2003 IRC	2 story SFR w/attached garage	Plan:Sloane	2007
New	Approved Basic 06-102491BP	2003 IRC	2 story SFR w/attached garage	Plan:Cadago	2007
New	Approved basic 06-127347 BP	2003 IRC	Plan# 1318 A	2-story sfr w/attached gar	2007
New	Approved Basic 05-126114BP	2003 IRC	2 story SFR w/attached garage	Plan:1127A	2007
New	Approved basic 06-127347 BP	2003 IRC	Plan# 1318 A	2-story sfr w/attached gar	2007
New	Approved Basic: 07-110125-BP	Plan No. 1017 B	2006 IRC/IRC	2 story SFR w/ attached 1 ca	2007
New	Approved basic 06-127347 BP	2003 IRC	Plan# 1318 A	2-story sfr w/attached gar	2007
New	Approved Basic #07-103244 BP	2 Story SFR	Plan #1717B	2003 IRC	2007
New	Approved basic 06-128047 BP	2003 IRC	Plan# 1017 A	2-story sfr w/attached ga	2007
New	Approved Basic 06-135357BP	2003 IRC	2 story SFR w/attached garage	Plan:1117 /	2007
New	Approved Basic 07-109361-BP	Builder No. 1318 C	2006 IRC/WSEC	2 story SFR w,	2007
New	Approved Basic 07-101856-BP	2003 IRC	Plan # 1731 C	2-story sfr w/ attached ga	2007
New	Approved basic 07-101584 BP	2003 IRC	Plan# 1711 A	2-story sfr w/attached garage	2007
New	Approved Basic 05-118601BP	2003 IRC	2 story SFR w/attached garage	Plan:1731B	2007
New	Approved Basic 06-127137BP	2003 IRC	Two-story SFR with attached garage	Plan: 1531C	2007
New	Approved Basic 04-116503BP		Plan: 1811B	Two-story SFR with attached garage -	2007
New	Approved basic 07-100997 BP	2003 IRC	Plan# 1711 B	2-story sfr w/attached ga	2007
New	Approved basic 06-127347 BP	2003 IRC	Plan# 1318 A	2-story sfr w/attached gar	2007
New	Approved Basic 07-110121-BP	2006 IRC	Plan # 1418 A	2-Story SFR w/ attached g	2007
New	Approved basic 06-127347 BP	2003 IRC	Plan# 1318 A	2-story sfr w/attached gar	2007
New	Approved Basic 07-110575-BP	Builder No. 1428A	2006 IRC / WSEC	2 story SFR no gar	2007
New	Approved basic 06-127347 BP	2003 IRC	Plan# 1318 A	2-story sfr w/attached gar	2007
New	Approved Basic #07-103244BP	2 story SFR	Plan: 1717B	2003 IRC	2007
New	Approved Basic 06-130350-BP	2003 IRC	Plan# 1717 C	2-story sfr w/attached garage	2007
New	Approved basic 06-126164 BP	2003 IRC	Plan# 1418 A	2-story sfr w/attached garage	2007
New	Approved Basic 04-120594BP	2 story SFR w/attached garage	2003 IRC	Plan:2011A	2007
New	Approved basic 06-126164 BP	2003 IRC	Plan# 1418 A	2-story sfr w/attached garage	2007
New	Approved Basic 05-126112BP	2003 IRC	2 story SFR w/attached garage	Plan:1418B	2007
New	Approved basic 06-126164 BP	2003 IRC	Plan# 1418 A	2-story sfr w/attached garage	2007
New	Approved Basic 05-126112BP	2003 IRC	2 story SFR w/attached garage	Plan:1418B	2007
New	Approved basic 06-125882 BP	2003 IRC	Plan# 1618 A	2-story sfr w/attached gara	2007
New	Pending Basic 07-109125-BP	2006 IRC	Plan # 1319 A	2-story SFR w/ attached garag	2007
New	Approved basic 06-125882 BP	2003 IRC	Plan# 1618 A	2-story sfr w/attached gara	2007
New	Approved basic 06-128047 BP	2003 IRC	Plan# 1017 A	2-story sfr w/attached ga	2007

Accessory Dwelling Units

Index # - File Name: 1.0022 - Single Family Dwellings Data\_Snohomish County.pdf

New	Approved Basic 06-135357BP	2003 IRC	2 story SFR w/attached garage	Plan:1117 A	2007
New	Approved Basic 07-110575-BP	Builder No. 1428A	2006 IRC / WSEC	2 story SFR no gar	2007
New	Approved Basic 07-110567-BP	Builder No. 1418C	2006 IRC / WSEC	2 story SFR w/ att	2007
New	Approved Basic 07-110575-BP	Builder No. 1428A	2006 IRC / WSEC	2 story SFR no gar	2007
New	Approved basic 06-126164 BP	2003 IRC	Plan# 1418 A	2-story sfr w/attached garage	2007
New	Approved Basic 04-116509BP	Plan: 1821B	Two-story SFR with attached garage - 2003 IRC	O	2007
New	Approved Basic 07-110566-BP	Builder No. 1428C	2006 IRC / WSEC	2 story SFR	2007
New	Approved Basic 07-111148-BP	2006 IRC	Plan # 1127 B	2- Story SFR w/ attached g	2007
New	Approved Basic 07-100690BP	2003 IRC	Two-story SFR with attached garage	Plan 1418C	2007
New	Approved basic 06-131905 BP	2003 IRC	Plan# 1319 C	2-story sfr w/attached gara	2007
New	Approved Basic 07-101232-BP	2003 IRC	Two-story SFR with attached garage	Plan 1127 B	2007
New	Approved basic 06-126164 BP	2003 IRC	Plan# 1418 A	2-story sfr w/attached garage	2007
New	Approved basic 06-125882 BP	2003 IRC	Plan# 1618 A	2-story sfr w/attached gara	2007
New	Approved Basic 05-126112BP	2003 IRC	2 story SFR w/attached garage	Plan:1418B	2007
New	Approved basic 06-126164 BP	2003 IRC	Plan# 1418 A	2-story sfr w/attached garage	2007
New	Approved Basic 05-126112BP	2003 IRC	2 story SFR w/attached garage	Plan:1418B	2007
New	Approved Basic 07-100690BP	2003 IRC	Two-story SFR with attached garage	Plan 1418C	2007
New	Approved Basic 07-110121-BP	2006 IRC	Plan # 1418 A	2-Story SFR w/ attached g	2007
New	Approved Basic 05-126112BP	2003 IRC	2 story SFR w/attached garage	Plan:1418B	2007
New	Approved Basic 07-100690BP	2003 IRC	Two-story SFR with attached garage	Plan 1418C	2007
New	Approved Basic 07-110129-BP	2006 IRC	Plan # 1638 A	2- Story SFR w/ attached	2007
New	Approved Basic 07-110121-BP	2006 IRC	Plan # 1418 A	2-Story SFR w/ attach	2007
New	Approved Basic 07-109671-BP	Builder No. 1418 B	2006 IRC / WSEC	2 story SFR w/ attach	2007
New	Approved Basic 07-109127-BP	2006 IRC	Plan # 1717 A	2-Story SFR w/ attached ga	2007
New	Approved Basic 07-109125-BP	2006 IRC	Plan # 1319 A	2-story SFR w/ attached gara	2007
New	Approved Basic 07-110121-BP	2006 IRC	Plan # 1418 A	2-Story SFR w/ attached g	2007
New	Approved basic 06-125880 BP	2003 IRC	Plan # 1638 A	2-story sfr NO garage	2007
New	Approved Basic 07-110123-BP	2006 IRC	Plan # 1117 B	2-Story SFR w/ attached g	2007
New	Approved Basic 07-109127-BP	2006 IRC	Plan # 1717 A	2-Story SFR w/ attached ga	2007
New	Approved Basic 05-100386BP	2003 IRC	Plan:1811A	2 story SFR w/attached garage	2007
New	Approved basic 07-110754 BP	2006 IRC	Plan# 1137 A	2-story sfr w/attached g	2007
New	Approved Basic 07-109671-BP	Builder No. 1418 B	2006 IRC / WSEC	2 story SFR w/ attach	2007
New	Approved basic 06-126164 BP	2003 IRC	Plan# 1418 A	2-story sfr w/attached garage	2007
New	Approved Basic 07-110126-BP	Plan No. 1017 C	2006 IRC/IBC	2 story SFR w/ attache	2007
New	Approved Basic 07-111717-BP	Plan No. 1318 B	2006 IRC/IBC	2 story SFR w/ attached 1 car g	2007
New	Approved Basic 07-109672-BP	Builder No. 1531 A	2006 IRC / WSEC	2 story SFR w/ attach	2007
New	Approved Basic 07-110121-BP	2006 IRC	Plan # 1418 A	2-Story SFR w/ attached g	2007
New	Approved Basic 07-114378-BP	Plan No. 1338 A	2006 IRC	2 story SFR cottage	2007
New	Approved Basic 07-110575-BP	Builder No. 1428A	2006 IRC / WSEC	2 story SFR no gar	2007
New	Approved Basic 07-111716-BP	Plan No. 1318 A	2006 IRC / IBC	2 story SFR w attached 1 car	2007
New	Rambler with attached garage				2007
New	22 ft x 60 ft SFR with attached garage				2007
New	2 story SFR/garage				2007
New	2559 sq ft single family residence with 770 sq ft attached garage.				2007
New	Two-story residence with attached garage				2007
New	SENT PERMIT FOLDER TO RECORDS ROOM 12/01/08 DM	3357 sq ft Rambler with attached Gar			2007
New	Approved basic 06-126880 BP	2003 IRC	Plan# TS 110 B/C	2-story sfr w/attached gara	2007

Accessory Dwelling Units

Index # - File Name: 1.0022 - Single Family Dwellings Data\_Snohomish County.pdf

New	Approved basic 06-124981 BP	2003 IRC	Plan TS 110 A	2-story sfr w/attached garage	2007
New	Approved basic 06-126880 BP	2003 IRC	Plan# TS 110 B/C	2-story sfr w/attached garage	2007
New	Approved basic 06-126880 BP	2003 IRC	Plan# TS 110 B/C	2-story sfr w/attached garage	2007
New	Approved Basic 06-135057BP	2003 IRC	Two-story SFR with attached garage	Plan: 3070-40-9	2007
New	Approved Basic 06-135064BP	2003 IRC	Two-story SFR with attached garage	Plan: 3189-39	2007
New	Approved Basic 06-135057BP	2003 IRC	Two-story SFR with attached garage	Plan: 3070-40-9	2007
New	Approved Basic 06-134865-BP	2203 IRC	Plan # 2368	2-Story SFR w/attached garage	2007
New	Two-story residence with attached garage				2007
New	Two story SFR with attached Garage				2007
New	Approved Basic 06-134865-BP	2203 IRC	Plan # 2368	2-Story SFR w/attached garage	2007
New	Approved Basic 06-135248 BP	2003 IRC	Plan: 2292		2007
New	Approved Basic 06-134865-BP	2203 IRC	Plan # 2368	2-Story SFR w/attached garage	2007
New	Approved Basic 06-134865-BP	2203 IRC	Plan # 2368	2-Story SFR w/attached garage	2007
New	SENT PERMIT FOLDER TO RECORDS ROOM 11/24/08 DM Rambler with attached garage				2007
New	SENT PERMIT FOLDER TO RECORDS ROOM 11/24/08 DM Two-story sfr with attached garage				2007
New	Approved Basic 05-101022BP	2003 IRC	Plan:5069A		2007
New	Approved Basic 06-134726 BP	2003 IRC	Plan: 2294		2007
New	Two-story SFR with attached garage - 2003 IRC				2007
New	Approved Basic 05-121525 BP	2003 IRC	Plan# 2591	2-story sfr w/attached garage	2007
New	2224 sq ft single family residence with 413 sq ft attached garage.				2007
New	Move - relocate SFR from parcel 3-008 to 3-006				2007
New	Approved Basic 07-102057BP	Two-story SFR with attached garage - 2003 IRC		Plan: 1657	2007
New	Approved Basic 07-102057BP	Two-story SFR with attached garage - 2003 IRC		Plan: 1657	2007
New	Approved Basic 07-102057BP	Two-story SFR with attached garage - 2003 IRC		Plan: 1657	2007
New	Approved Basic 07-102057BP	Two-story SFR with attached garage - 2003 IRC		Plan: 1657	2007
New	Approved Basic 06-134744 BP	2003 IRC	Plan: 2222		2007
New	Approved Basic 06-134744 BP	2003 IRC	Plan: 2222		2007
New	Approved Basic 06-134744 BP	2003 IRC	Plan: 2222		2007
New	2-Story Single Family Residence with attached garage.				2007
New	Approved Basic # 07-102230 BP	2003 IRC	Plan: 2406	Two story SFR with attached Garage	2007
New	Approved Basic 06-134846 BP	2003 IRC	Plan: 2495 Sahalee2	Two-story SFR w/ attached Garage	2007
New	Approved Basic 06-135171BP	2003 IRC	Two-story SFR with attached garage	Plan: 2672 Beec	2007
New	Approved Basic 06-135171BP	2003 IRC	Two-story SFR with attached garage	Plan: 2672 Beec	2007
New	Approved Basic 07-100057BP	2003 IRC	Plan: Mazama 2364	2-story residence w/ attached garage	2007
New	Approved Basic 07-100057 BP	2003 IRC	Plan: Mazama 2364	Two-s	2007
New	Rambler style sfr w/attached garage				2007
New	Two story SFR with attached Garage				2007
New	Approved Basic 05-120707BP	2003 IRC	2 story SFR w/attached garage	Plan:2155	2007
New	Approved Basic #05-118418 BP	2003 IRC	Plan #2452	Two story SFR w/ Attached G	2007
New	2-story sfr w/attached garage				2007
New	Approved Basic 06-126470BP	Two-story SFR with 3-car garage	2003IRC	Plan: 2958	2007
New	Approved Basic 06-126476BP	Two-story SFR with 3-car garage	2003 IRC	Plan: 2777	2007
New	Approved Basic 06-126470BP	Two-story SFR with 3-car garage	2003IRC	Plan: 2958	2007
New	Approved Basic 06-126470BP	Two-story SFR with 3-car garage	2003IRC	Plan: 2958	2007
New	Approved Basic 05-120000BP	2003 IRC	Plan: Rochester	2 story SFR w/attached garage	2007
New	Approved Basic 06-126476BP	Two-story SFR with 3-car garage	2003 IRC	Plan: 2777	2007
New	Rambler style sfr w/attached garage				2007

Accessory Dwelling Units

Index # - File Name: 1.0022 - Single Family Dwellings Data\_Snohomish County.pdf

New	Approved Basic 07-100453BP	2003 IRC	Two-story SFR with attached garage	Plan: 2	2007
New	Approved Basic 07-100455BP	2003 IRC	Two-story SFR with attached garage	Plan: 185	2007
New	SENT PERMIT FOLDER TO RECORDS ROOM 11/21/08 DM Approved Basic # 07-100454 BP				2007
New	Approved Basic 07-100461BP	2003 IRC	Two-story SFR with attached garage	Plan: 227	2007
New	SENT PERMIT FOLDER TO RECORDS ROOM 12/01/08 DM Approved Basic 07-100462BP				2007
New	SENT PERMIT FOLDER TO RECORDS ROOM 11/21/08 DM Approved basic 06-127991 BP				2007
New	2 story home w/ attached garage				2007
New	Approved Basic 07-100463BP	2003 IRC	Two-story SFR with attached garage	Plan: 17	2007
New	SENT PERMIT FOLDER TO RECORDS ROOM 11/24/08 DM Approved Basic # 07-100452 BP				2007
New	Approved Basic 07-100453BP	2003 IRC	Two-story SFR with attached garage	Plan: 2	2007
New	Approved Basic # 07-100454 BP	2003 IRC	Plan: 1936 Two story w/ attached 2 car Ga		2007
New	SENT PERMIT FOLDER TO RECORDS ROOM 11/21/08 DM Approved Basic # 07-100454 BP				2007
New	Approved Basic # 07-100452 BP	2003 IRC	Plan: 1936 Two story w/ attached 2 car Ga		2007
New	Approved Basic # 07-100452 BP	2003 IRC	Plan: 1936 Two story w/ attached 2 car Ga		2007
New	Approved Basic # 07-100454 BP	2003 IRC	Plan: 1936 Two story w/ attached 2 car Ga		2007
New	Approved Basic 07-100463BP	2003 IRC	Two-story SFR with attached garage	Plan: 17	2007
New	Approved Basic 07-100453BP	2003 IRC	Two-story SFR with attached garage	Plan: 2	2007
New	Approved Basic # 07-100452 BP	2003 IRC	Plan: 1936 Two story w/ attached 2 car Ga		2007
New	Approved Basic # 07-100454 BP	2003 IRC	Plan: 2146 Two story w/ attached 2 car Ga		2007
New	Approved Basic 07-100455BP	2003 IRC	Two-story SFR with attached garage	Plan: 185	2007
New	Approved Basic # 07-100452 BP	2003 IRC	Plan: 1936 Two story w/ attached 2 car Ga		2007
New	Approved Basic 07-100463BP	2003 IRC	Two-story SFR with attached garage	Plan: 17	2007
New	Approved Basic 07-100463BP	2003 IRC	Two-story SFR with attached garage	Plan: 17	2007
New	2 story SFR with finished basement and attached garage				2007
New	2 story SFR with finished basement and attached garage				2007
New	Approved basic 05-100212BP		2 story w/attached garage	2003 IRC Plan:50	2007
New	Approved Basic 04-117108BP	2003 IRC	Plan: 5038 AM Two-story SFR with att		2007
New	Approved Basic 04-116374BP	2 story SFR w/attached garage		2003 IRC Plan:5055A	2007
New	Approved Basic 04-117108BP	2003 IRC	Plan: 5038 AM Two-story SFR with att		2007
New	Approved basic 05-125351 BP	2003 IRC	Plan# 3117 A	2-story sfr w/attached gar	2007
New	Approved Basic 04-120673BP		Plan: 5039 AM	Two-story SFR with 3-car/4	2007
New	Approved Basic 05-101022BP		2003 IRC	Plan:5069A	2007
New	Researched microfilm on 5/3/2019 and permit was finalled on 7/25/2007 csf EXPIRED WITHOU				2007
New	Approved basic 05-126157 BP	2003 IRC	Plan# 2700 B	2-story sfr w/attached g	2007
New	Approved Basic 05-126785 BP			Plan: T2734-03A-N	2007
New	Approved basic 05-126160 BP	2003 IRC	Plan# 3036 B	2-story sfr w/attached ga	2007
New	Approved Basic 05-126785 BP		Plan: T2734-03A-N	Two-story SFR	2007
New	Approved basic 05-128452 BP	2003 IRC	Plan# 2440 BE	2-story sfr w/attached gar	2007
New	Approved Basic 04-120907BP	2 story SFR w/attached garage		2003 IRC Plan:2140B	2007
New	Two story SFR with Semi-finished Basement & attached Garage				2007
New	Approved Basic 04-120908BP	2 story SFR w/attached garage		2003 IRC Plan:2140C	2007
New	Approved Basic 07-111790-BP	Plan No. 2440A - EF	2006 IRC	2 story SFR w/ Attached g	2007
New	Approved Basic 07-108411-BP	Builder s plan No: 2440A	2006 IRC	2 story SFR w	2007
New	Approved Basic 04-120906BP	2 story SFR w/attached garage		2003 IRC Plan:2140A	2007
New	Approved Basic 04-120908BP	2 story SFR w/attached garage		2003 IRC Plan:2140C	2007
New	Approved basic 05-126158 BP	2003IRC	Plan# 2700 A	2-story sfr w/attached g	2007
New	Approved basic 05-125351 BP	2003 IRC	Plan# 3117 A	2-story sfr w/attached gar	2007

Accessory Dwelling Units

Index # - File Name: 1.0022 - Single Family Dwellings Data\_Snohomish County.pdf

New	Approved Basic 07-111809-BP	Plan No. 3036 B	2006 IRC	2 story SFR w/ attached ga	2007
New	Approved Basic 05-126785 BP	Plan: T2734-03A-N		Two-story SFR	2007
New	74 ft x 86 ft two story SFR with attached garage				2007
New	Approved Basic #07-110629 BP	2006 IRC	Plan: Glacier B	Two Story SFR w/attached garage	2007
New	Approved Basic #07-110631 BP	2006 IRC	Plan: Whitney B	Two Story SFR w/attached garage	2007
New	Approved Basic #07-113368 BP	2006 IRC	Plan: Tyndall A	Two Story SFR w/attached gara	2007
New	2-Story SFR w/attached garage.				2007
New	Approved basic 06-126631 BP	2003 IRC	Plan# 2278 Alt	2-story sfr w/attached gara	2007
New	Approved Basic 06-135938-BP	2003 IRC	Plan # 1943-1	2-story SFR w/ attached ga	2007
New	Approved Basic 06-102846BP	2003 IRC	2 story SFR w/attached garage	Plan:1848	2007
New	Approved Basic #07-110631 BP	2006 IRC	Plan: Whitney B	Two Story SFR w/attached garage	2007
New	Approved Basic #07-110629 BP	2006 IRC	Plan: Glacier B	Two Story SFR w/attached garage	2007
New	Approved Basic #07-110630 BP	2006 IRC	Plan: Whitney A	Two Story SFR w/attached gara	2007
New	Approved Basic #07-110629 BP	2006 IRC	Plan: Glacier B	Two Story SFR w/attached garage	2007
New	Approved Basic 05-126785 BP	2003 IRC	Plan: T2734-03A-N	Two-story SFR	2007
New	Approved basic 05-126160 BP	2003 IRC	Plan# 3036 B	2-story sfr w/attached ga	2007
New	Approved Basic 05-126785 BP	2003 IRC	Plan: T2734-03A-N	Two-story SFR	2007
New	Approved basic 05-125351 BP	2003 IRC	Plan# 3117 A	2-story sfr w/attached gar	2007
New	Approved basic 05-126157 BP	2003 IRC	Plan# 2700 B	2-story sfr w/attached g	2007
New	Approved basic 05-126159 BP	2003 IRC	Plan# 3036 A	2-story sfr w/attache	2007
New	Approved Basic 05-126785 BP			Plan: T2734-03A-N	2007
New	Approved Basic 07-111803-BP	Plan No. 2472A - SL	2006 IRC	2 story SFR w/ attached gara	2007
New	837 sq ft SFR with attached Garage				2007
New	Rambler w/daylight basement & garage				2007
New	Rambler with 327 sf 2nd floor area and with attached garage				2007
New	Two story SFR with attached Garage				2007
New	Approved basic 06-126631 BP	2003 IRC	Plan# 2278 Alt	2-story sfr w/attached gara	2007
New	Two-story sfr with attached garage				2007
New	SENT PERMIT FOLDER TO RECORDS ROOM 10/22/08 DM Two-story SFR with attached garage -				2007
New	Approved Basic 05- 123059BP		2003 IRC	Plan: 2160 Two-story SFR w	2007
New	Approved Basic 06-127259BP	2003IRC		Two-story SFR with attached garage Plan: 21	2007
New	Approved Basic 05- 123059BP		2003 IRC	Plan: 2160 Two-story SFR w	2007
New	Approved Basic 06-127259BP	2003IRC		Two-story SFR with attached garage Plan: 21	2007
New	Approved basic 07-100963 BP	2003 IRC	Plan# 1784	2-story sfr w/attached gar	2007
New	Approved Basic 06-127259BP	2003IRC		Two-story SFR with attached garage Plan: 21	2007
New	Approved Basic 05-122829BP	2003 IRC		2 story SFR w/attached garage Plan:1809	2007
New	Approved Basic 05-116799BP		2003 IRC	Plan:2597 3 Car	2007
New	SENT PERMIT FOLDER TO RECORDS ROOM 11/24/08 DM Approved Basic #06-129185 BP 21				2007
New	Approved Basic 05-122829BP	2003 IRC		2 story SFR w/attached garage Plan:1809	2007
New	Approved basic 06-126287 BP	2003 IRC	Plan# 3105	2-story sfr w/attached garage	2007
New	Approved Basic 05-116166BP		2003 IRC	Plan: Tyhaka	2007
New	Approved Basic 05- 123059BP		2003 IRC	Plan: 2160 Two-story SFR w	2007
New	Approved Basic 05-122829BP	2003 IRC		2 story SFR w/attached garage Plan:1809	2007
New	Approved basic 07-100963 BP	2003 IRC	Plan# 1784	2-story sfr w/attached gar	2007
New	Approved Basic 06-127259BP	2003IRC		Two-story SFR with attached garage Plan: 21	2007
New	Approved Basic 06-103981BP		2003 IRC	2 story SFR w/attached garage Plan:304	2007
New	Approved basic 06-126287 BP	2003 IRC	Plan# 3105	2-story sfr w/attached garage	2007

Accessory Dwelling Units

Index # - File Name: 1.0022 - Single Family Dwellings Data\_Snohomish County.pdf

New	Approved Basic 04-120167BP	2 story SFR w/attached garage	2003 IRC	Plan:2597	2007
New	Approved basic 06-125932 BP	2003 IRC	Plan# 2248	2-story sfr w/attached gara	2007
New	Approved basic 06-125932 BP	2003 IRC	Plan# 2248	2-story sfr w/attached gara	2007
New	Approved basic 06-126287 BP	2003 IRC	Plan# 3105	2-story sfr w/attached garage	2007
New	SENT PERMIT FOLDER TO RECORDS ROOM 10/23/08 DM 3221 sq ft SFR with 952 attached gara				2007
New	Two story SFR w/ attached 3 car garage		2006 IRC		2007
New	SENT PERMIT FOLDER TO RECORDS ROOM 12/01/08 DM Two-story residence with attached ga				2007
New	Approved Basic 07-109360-BP	Builder No. Duplex 1764	2006 IRC	One Story	2007
New	SENT PERMIT FOLDER TO RECORDS ROOM 12/01/08 DM New SFR two story with attached gara				2007
New	*Issued under tax roll # 005380-000-139-03* 2 story Duplex w/ 2 car garage				2007
New	SENT PERMIT FOLDER TO RECORDS ROOM 12/01/08 DM Approved basic 07-112026 BP 20				2007
New	Approved Basic No. 07-109699 BP	Builder No. 1865-B	2006 IRC	2 story SFR w/ attachec	2007
New	Approved basic 07-112026 BP	2006 IRC	Plan# 1339 B	Rambler sfr w/attached ga	2007
New	Approved basic 07-111993 BP	2006 IRC	Plan# 1253	Rambler sfr w/attached garag	2007
New	Approved basic 07-105280 BP	2006 IRC	Plan# 1493	Rambler w/attached garağ	2007
New	Approved Basic No. 07-109699 BP	Builder No. 1865-B	2006 IRC	2 story SFR w/ attachec	2007
New	2250 sq ft single family residence w/ attached garage.		2006 IRC		2007
New	Approved Basic No. 07-113006-RK	Builder Plan No 3514	2006 IRC	2 story SFR w/ attac	2007
New	This structure was one of the first 6 residences completed in the Lambert Creek. Final inspector				2007
New	This structure was one of the first 6 residences completed in the Lambert Creek. Final inspector				2007
New	This structure was one of the first 6 residences completed in the Lambert Creek. Final inspector				2007
New	This structure was one of the first 6 residences completed in the Lambert Creek. Final inspector				2007
New	This structure was one of the first 6 residences completed in the Lambert Creek. Final inspector				2007
New	Two story Duplex with attached Garage				2007
New	*Issued under tax roll # 005270-000-015-01* Approved basic 07-111859 BP Plan Nu				2007
New	*Issued under tax roll # 005270-000-015-01* Approved basic 07-111859 BP Plan Numbe				2007
New	850 square foot Single Family Residence w/1944 square foot garage & 1094 storage				2007
New	2 story SFR w/ attached garage				2007
New	Two-story residence with attached garage				2007
New	Two story SFR with attached Garage				2007
New	Two story SFR with attached Garage				2007
New	Two-story residence with attached garage				2007
New	Approved Basic 07-112556-BP	2006 IRC	Plan # 1840	2- Story SFR w/ attached gar	2007
New	64 ft x 85 ft SFR with semi-finished basement and attached garage				2007
New	2003 IRC - 2 story single family residence w/ attached garage.				2007
New	28 ft x 36 ft two story SFR with attached garage				2007
New	40 ft X 70 ft Triple-Wide Mobile Home				2007
New	Approved Basic 07-108808-BP	2006 IRC	Plan #3019-A	2-Story SFR w/attached g	2007
New	Approved basic 07-108259 BP	2006 IRC	Plan# 3026-B	2-story sfr w/attached ga	2007
New	Approved Basic 07-108807-BP	2006 IRC	Plan # 3915-B	2-Story SFR w/ attached garage	2007
New	Approved Basic 07-108811-BP	2006 IRC	Plan #3022-B	2-Story SFR w/attached garag	2007
New	Approved Basic 07-108806-BP	2006 IRC	Plan # 3915-A	2- Story SFR w/ attached ga	2007
New	Approved Basic 07-108806-BP	2006 IRC	Plan # 3915-A	2- Story SFR w/ attached ga	2007
New	Approved basic 07-108262 BP	2006 IRC	Plan# 3027-C	2-story sfr w/attached ga	2007
New	SENT PERMIT FOLDER TO RECORDS ROOM 12/01/08 DM Approved Basic 07-108809-BP 200				2007
New	Approved basic 07-108257 BP	2006 IRC	Plan# 3026-A	2-story sfr w/attached ga	2007



Accessory Dwelling Units

Index # - File Name: 1.0022 - Single Family Dwellings Data\_Snohomish County.pdf

New	Approved basic 07-108274 BP	2006 IRC	Plan# 4010Den-C	2-story sfr w/ den & attached g	2007
New	Approved Basic 06-101605 BP	2003 IRC	Builder s Plan: Mt. Index - 2 (2 car/3 car) Tw		2007
New	2-Story SFR w/attached garage.				2007
New	2-Story single family residence w/ attached garage.	2003 IRC			2007
New	Approved Basic 04-112756BP	2 story SFR w/attached garage	2003 IRC	Plan: Mt Rainier	2007
New	Approved Basic 04-1120161 BP		Plan: Mt. Index	2 story sfr w/attached 3-ca	2007
New	Two-story residence with attached garage				2007
New	SENT PERMIT FOLDER TO RECORDS ROOM 11/24/08 DM	New 2 story SFR w/ attached garage 2			2007
New	2-story w/garage				2007
New	2-Story SFR w/attached garage		Bldr plan # M3025A3F-O		2007
New	2-Story SFR w/attached garage.		Bldr s. Plan# M2535A3F-1		2007
New	Approved Basic 06-101194BP	2003 IRC	Rambler with attached garage	Plan:Pilchuck 2/E	2007
New	Approved Basic 06-101605 BP	2003 IRC	Builder s Plan: Mt. Index - 2 (2 car/3 car) Tw		2007
New	SENT PERMIT FOLDER TO RECORDS ROOM 11/26/08 DM	2-story sfr w/attached garage			2007
New	Approved Basic 06-125770BP	Two-story SFR with 3-car garage	2003 IRC	Plan: Cascade #1	2007
New	Approved Basic 04-1120161 BP		Plan: Mt. Index	2 story sfr w/attached 3-ca	2007
New	Rambler with attached garage				2007
New	Approved Basic 04-112756BP	2 story SFR w/attached garage	2003 IRC	Plan: Mt Rainier	2007
New	Approved Basic 06-125770BP	Two-story SFR with 3-car garage	2003 IRC	Plan: Cascade #1	2007
New	Approved Basic 06-101194BP	2003 IRC	Rambler with attached garage	Plan:Pilchuck 2/E	2007
New	Approved Basic 04-119145BP		Plan 1786	Two-story SFR with attached	2007
New	SENT PERMIT FOLDER TO RECORDS ROOM 11/24/08 DM	New 2 bedroom home above 2 car ga			2007
New	Approved Basic #07-107187 BP	Plan: Appleton Gable B-2	2003 IRC	2-Story SFR w/ attach	2007
New	Approved 07-102605 BP	2003 IRC	Plan# Glacier Gable B (I)	2-story sfr w/attached	2007
New	Approved Basic #07-107863 BP	2003 IRC	Plan: Trinity Gable B (I)	Two Story SFR w/attache	2007
New	Approved Basic #07-107864 BP	2003 IRC	Plan: Tyndall Gable B (I)	Two Story SFR w/attache	2007
New	Approved basic 07-102603 BP	2003 IRC	Plan# Appleton Gable A (I)	2-story sfr w/at	2007
New	Approved 07-102605 BP	2003 IRC	Plan# Glacier Gable B (I)	2-story sfr w/attached	2007
New	Approved Basic #07-107859 BP	2003 IRC	Plan: Jasper Galve A (I)	Two Story w/attached gar	2007
New	Approved 07-102605 BP	2003 IRC	Plan# Glacier Gable B (I)	2-story sfr w/attached	2007
New	APPROVED Basic #07-105840 BP	Plan: Monroe Gable B (I)	2003 IRC	Two Story SFR	2007
New	Approved basic 06-133589 BP	2003 IRC	Plan# Glacier Gable	2-story sfr w/attached g	2007
New	Approved Basic 07-101419 BP	2003 IRC	Plan: Madison Hip B (I)	Two-story home w/attache	2007
New	2 story SFR w/ attached garage				2007
New	2 story SFR w/ attached garage				2007
New	SENT PERMIT FOLDER TO RECORDS ROOM 11/24/08 DM	Two-story single family residence w/ a			2007
New	*Issued under tax roll # 005741-000-062-00*	Approved Basic # 07-109717 BP	2006 IRC	Plan	2007
New	*Issued under tax roll # 008534-000-004-03*	Approved Basic 07-103268-BP	2003 IRC		2007
New	2 story SFR w/ attached 3 car garage	*Issued under tax roll 003944-062-013-00*			2007
New	2 story SFR w/ attached 3 car garage (4 bedroom plus den & bonus room)				2007
New	Two Story SFR with Attached Garage				2007
New	Two Story SFR with Attached Garage				2007
New	SENT PERMIT FOLDER TO RECORDS ROOM 12/01/08 DM	Two-story residence with attached ga			2007
New	Approved Basic 06-101849BP	2003 IRC	Plan: Dahlia 2553	Rambler style SFR with attach	2007
New	Approved Basic 06-102242BP	Rambler style SFR with 3-car garage -	2003 IRC	Plan: Wisteri	2007
New	Approved Basic 06-101849BP	2003 IRC	Plan: Dahlia 2553	Rambler style SFR with atta	2007
New	Approved basic 05-127403 BP	2003 IRC	Plan# 50060 A-2	2-story sfr w/attache	2007

Accessory Dwelling Units

Index # - File Name: 1.0022 - Single Family Dwellings Data\_Snohomish County.pdf

New	Approved Basic 07-109678 BP	2006 IRC	Plan: 621-1D	Two-story sfr with attached g	2007
New	Approved Basic 07-109302- BP	2006 IRC	3-Story-SFR with 2-car garage	Plan: 623-2D,E TH	2007
New	Approved Basic 07-109302- BP	2006 IRC	3-Story-SFR with 2-car garage	Plan: 623-2D,E TH	2007
New	Approved Basic 07-109302- BP	2006 IRC	3-Story-SFR with 2-car garage	Plan: 623-2D,E TH	2007
New	Approved Basic 07-109302- BP	2006 IRC	3-Story-SFR with 2-car garage	Plan: 623-2D,E TH	2007
New	Approved Basic 07-109678 BP	2006 IRC	Plan: 621-1D	Two	2007
New	Split Entry style SFR w/unfinished basement & basement garage.				2007
New	*Issued under tax roll # 005741-000-058-00* Approved Basic # 07-106801 BP 2006IRC Plan:				2007
New	Approved Basic 07-108627 BP	2006 IRC	Two-story SFR with 2-car garage	Plan: 625-2F	2007
New	Approved Basic 07-108506 BP	2006 IRC	Two-story SFR with 2-car garage	Plan: 624-1D,E,F	2007
New	Approved Basic 07-109302- BP	2006 IRC	3-Story-SFR with 2-car garage	Plan: 623-2D,E TH	2007
New	Approved Basic 07-109678 BP	2006 IRC	Plan: 621-1D	Two	2007
New	Approved basic 07-110800 BP	2006 IRC	Plan# 1875	2-story sfr w/attached g	2007
New	Approved basic 07-106996 BP	2006 IRC	Plan# 2243 B	2-story sfr w/attached ga	2007
New	Approved basic 07-110791 BP	2006 IRC	Plan# 2272	2-story sfr w/attached garag	2007
New	Approved basic 07-110789 BP	2006 IRC	Plan# 2537	2-story sfr w/attached garage	2007
New	Approved basic 07-110786 BP	2006 IRC	Plan# 1500	Ramber style sfr w/attache	2007
New	Approved basic 07-110795 BP	2006 IRC	Plan# 2064	2-story sfr w/attached gi	2007
New	SENT PERMIT FOLDER TO RECORDS ROOM 12/01/08 DM Approved basic 07-110797 BP 2				2007
New	SENT PERMIT FOLDER TO RECORDS ROOM 11/26/08 DM 2-Story SFR w/attached garage.				2007
New	Approved basic 07-101882 BP	2003 IRC	Plan# ARM1	2-story sfr w/attached garage *pe	2007
New	Approved basic 07-101882 BP	2003 IRC	Plan# ARM1	2-story sfr w/attached garage	2007
New	THIS FINAL SUPERSEDES THE PREVIOUS EXPIRED STATUS 2/12/16 DM EXPIRED WITHOUT COU				2007
New	1767 sq ft SFR Rambler with attached Garage				2007
New	Approved Basic 07-108142-BP	2006 IRC	Plan No. 2683	2 story SFR w/ attached gara	2007
New	Approved Basic 07-106485 BP	2006 IRC	Plan: 2774	Two-story residence with att	2007
New	Approved Basic 07-106488 BP	2006 IRC	Plan: 3016	Two-story residence with	2007
New	SENT PERMIT FOLDER TO RECORDS ROOM 12/01/08 DM Approved Basic 07-108142-BP 200				2007
New	SENT PERMIT FOLDER TO RECORDS ROOM 12/01/08 DM Approved Basic 07-106485 BP				2007
New	SENT PERMIT FOLDER TO RECORDS ROOM 11/26/08 DM *Issued under tax roll # 005973-000-0				2007
New	Two story SFR with attached Garage				2007
New	SFR Rambler with attached garage				2007
New	2 story SFR w/ attached garage				2007
New	Two story SFR with attached Garage				2007
New	SENT PERMIT FOLDER TO RECORDS ROOM 12/01/08 DM Two story home with attached 3 car g				2007
New	SENT PERMIT FOLDER TO RECORDS ROOM 12/01/08 DM Rambler style home with attached 3 c				2007
New	SENT PERMIT FOLDER TO RECORDS ROOM 12/01/08 DM New 7800 sq. ft rambler SFR w/ attac				2007
New	2 story SFR w/ first story garage and 2nd story living				2007
New	Two story SFR with attached Garage issued under tax roll number 003944-035-043-00				2007
New	SENT PERMIT FOLDER TO RECORDS ROOM 12/01/08 DM 2-story duplex				2007
New	SENT PERMIT FOLDER TO RECORDS ROOM 12/01/08 DM 2-story duplex				2007
New	SENT PERMIT FOLDER TO RECORDS ROOM 12/01/08 DM 2-story duplex				2007
New	SENT PERMIT FOLDER TO RECORDS ROOM 12/01/08 DM 2-story duplex				2007
New	Two-story residence with attached garage				2007
New	2-Story SFR w/attached garage. **Permits issued under tax#290709-003-014-00**				2007
New	SENT PERMIT FOLDER TO RECORDS ROOM 12/01/08 DM 2-Story SFR over finished daylight basi				2007
New	2 story home with 3 car attached garage, 3 bedrooms with playroom, library & den				2008

Accessory Dwelling Units

Index # - File Name: 1.0022 - Single Family Dwellings Data\_Snohomish County.pdf

New	Two story SFR					2008
New	Approved Basic 08-108881-BP	Plan No 1300 / 2097 A	2006 IRC	Split Level SFR w/ at		2008
New	Approved Basic: 08-108885-BP	Plan No. 1991 B	2006 IRC	2 story SFR w/ attachec		2008
New	Approved Basic 08-110302-BP	Plan No 1992	2006 IRC	2 story SFR w/ attached garage		2008
New	Approved Basic 08-110301-BP	Plan No. 1414 / 2106	2006 IRC	Split Level SFR w/ attached ga		2008
New	SFR with Attached Garage					2008
New	SFR with Attached Garage					2008
New	2 story sfr w/attached garage					2008
New	2-story sfr w/attached garage					2008
New	2 story sfr w/attached garage					2008
New	Approved Basic 08-105019-BP	Plan No. Glenbrook 2	2006 IRC	2 story SFR w/ attached garage		2008
New	Approved Basic 08-105020-BP	Plan No. Brennan 2	2006 IRC	2 story SFR w/attached garage		2008
New	2 story SFR with attached garage					2008
New	SENT PERMIT FOLDER TO RECORDS ROOM 11/04/08 DM New two story Duplex w/ attached ga					2008
New	Approved basic 08-100888 BP	2006 IRC	Plan# 1781-2car	2-story sfr w/attached		2008
New	New SFR w/ attached garage					2008
New	Approved Basic 08-105018-BP	Plan No. Edgewood 2	2006 IRC	2 story SFR w/attached ga		2008
New	Approved Basic 07- 108877 BP	2006 IRC	Plan #2020-A	2 story SFR w/ attached Garage		2008
New	Approved Basic 07- 108877 BP	2006 IRC	Plan #2020-A	2 story SFR w/ attached Garage		2008
New	Approved Basic 07- 108877 BP	2006 IRC	Plan #2020-A	2 story SFR w/ attached Garage		2008
New	Approved Basic 07- 108877 BP	2006 IRC	Plan #2020-A	2 story SFR w/ attached Garage		2008
New	2 story SFR w/ attached garage					2008
New	Approved Basic #08-100055 BP	2006 IRC	Plan: 1380 H	Two Story SFR with attached Garage		2008
New	Approved Basic 08-100694-BP	Plan No 1852H	2006 IRC	two story SFR w/ attached garage		2008
New	Approved basic 08-100505 BP	2006 IRC	Plan# 1852 G	2-story sfr w/attached		2008
New	Approved Basic 08-100694-BP	Plan No 1852H	2006 IRC	two story SFR w/ attached garage		2008
New	Approved Basic 07-115006-BP	Plan No 2104H	2006 IRC	two story SFR w/ attached garage		2008
New	Approved Basic 07-115007-BP	Plan No 2104G	2006 IRC	2 story SFR w/ attached garage		2008
New	Approved Basic 07-115006-BP	Plan No 2104H	2006 IRC	two story SFR w/ attached garage		2008
New	Approved basic 08-100505 BP	2006 IRC	Plan# 1852 G	2-story sfr w/attached		2008
New	Approved Basic 08-100056-BP	Plan No. 1600G	2006 IRC	2 story SFR w/ attached gara		2008
New	Approved Basic 08-100053-BP	Plan No. 1124	2006 IRC	1 story SFR w/ attached garage		2008
New	Approved Basic 08-100057-BP	Plan No. 1600H	2006 IRC	2 story SFR w/ attached gara		2008
New	Approved Basic 08-100694-BP	Plan No 1852H	2006 IRC	two story SFR w/ attached garage		2008
New	Approved Basic 08-100056-BP	Plan No. 1600G	2006 IRC	2 story SFR w/ attached gara		2008
New	(1) Approved Basic 08-100057-BP	Plan No. 1600H	2006 IRC	2 story SFR w/ attached g		2008
New	Approved basic 07-111867 BP	2006 IRC	Plan# 2003 H	2-story sfr w/attached gara		2008
New	Approved Basic 07-115007-BP	Plan No 2104G	2006 IRC	2 story SFR w/ attached garage		2008
New	Approved basic 07-111867 BP	2006 IRC	Plan# 2003 H	2-story sfr w/attached gara		2008
New	Approved Basic 07-115006-BP	Plan No 2104H	2006 IRC	two story SFR w/ attached garage		2008
New	Approved Basic 08-100107-BP	Plan No. 2225H	2006 IRC	2 story SFR w/attached garag		2008
New	Approved Basic 08-100105-BP	Plan No. 2005 H	2006 IRC	2 story SFR w/ attached gar		2008
New	Approved Basic 08-100107-BP	Plan No. 2225 H	2006 IRC	2 story SFR w/ attached gar		2008
New	Approved Basic 08-101495 BP		2006 IBC	Plan 2043 Rambl		2008
New	Approved Basic 08-100057-BP	Plan No. 1600H	2006 IRC	2 story SFR w/ attached gara		2008
New	Permit cancelled per applicant 09-28-09 jrlind no refund inspections Approved Basic 08-100053					2008
New	Approved Basic 07- 108877 BP	2006 IRC	Plan #2020-A	2 story SFR w/ attached Garage		2008

Accessory Dwelling Units

Index # - File Name: 1.0022 - Single Family Dwellings Data\_Snohomish County.pdf

New	Approved Basic 08-100056-BP	Plan No. 1600G	2006 IRC	2 story SFR w/ attached gara	2008
New	Approved Basic 08-100694-BP	Plan No 1852H	2006 IRC	two story SFR w/ attached gara	2008
New	Approved basic 08-100505 BP	2006 IRC	Plan# 1852 G	2-story sfr w/attached	2008
New	Approved Basic 08-100694-BP	Plan No 1852H	2006 IRC	two story SFR w/ attached gara	2008
New	Approved basic 08-100505 BP	2006 IRC	Plan# 1852 G	2-story sfr w/attached	2008
New	Approved Basic 08-100057-BP	Plan No. 1600H	2006 IRC	2 story SFR w/ attached gara	2008
New	Approved Basic 08-100694-BP	Plan No 1852H	2006 IRC	two story SFR w/ attached gara	2008
New	Approved Basic 08-100053-BP	Plan No. 1124	2006 IRC	1 story SFR w/ attached garage	2008
New	Approved Basic 08-100053-BP	Plan No. 1124	2006 IRC	1 story SFR w/ attached garage	2008
New	Approved Basic 08-100053-BP	Plan No. 1124	2006 IRC	1 story SFR w/ attached garage	2008
New	Approved Basic 08-100053-BP	Plan No. 1124	2006 IRC	1 story SFR w/ attached garage	2008
New	Approved Basic 08-100053-BP	Plan No. 1124	2006 IRC	1 story SFR w/ attached garage	2008
New	Approved Basic 08-100053-BP	Plan No. 1124	2006 IRC	1 story SFR w/ attached garage	2008
New	Approved Basic 08-100053-BP	Plan No. 1124	2006 IRC	1 story SFR w/ attached garage	2008
New	Approved Basic 08-100053-BP	Plan No. 1124	2006 IRC	1 story SFR w/ attached garage	2008
New	Approved Basic 08-100053-BP	Plan No. 1124	2006 IRC	1 story SFR w/ attached garage	2008
New	Unit 3 of Building C				2008
New	Building F Unit 4, Lot 41				2008
New	Unit 4 of Building J				2008
New	Two-story residence with attached garage				2008
New	Two-story residence with attached garage				2008
New	Building F, Unit 3, Lot 42				2008
New	Building F, Unit 2, Lot 43				2008
New	Building F, Unit 1, Lot 44				2008
New	Unit 3 of Building J				2008
New	Unit 2 of Building J				2008
New	Unit 1 of Building J				2008
New	Two-story residence with attached garage				2008
New	Unit 2 of Building C				2008
New	Unit 1 of Building C				2008
New	Two story SFR				2008
New	SFR Rambler				2008
New	two story SFR with finished basement and attached garage				2008
New	2 story SFR *permit issued under 270521-003-021-00*				2008
New	Approved Basic #08-108247	2006 IRC	Plan: 1670	Two story SFR with attached Garage	2008
New	Approved Basic 07-114694-BP	2006 IRC	Plan # 2370	2-Story SFR w/ attached ga	2008
New	2-story SFR w/garage and covered porch				2008
New	SFR Rambler with attached garage				2008
New	2 story SFR w/ attached garage				2008
New	2 story SFR				2008
New	two story SFR w/ attached garage				2008
New	Rambler w/attached garage				2008
New	Rambler w/attached garage				2008
New	Rambler style SFR				2008
New	Approved Basic 08-111009 BP	Plan: 1633	2006 IRC	1633 sq ft Rambler with attached Ga	2008
New	2006 KIT Home Builders Cedar Canyon Mt. Shasta			Mobile Home	2008
New	2 story Duplex w/ attached garage				2008

Accessory Dwelling Units

Index # - File Name: 1.0022 - Single Family Dwellings Data\_Snohomish County.pdf

New	SFR w/ attached garage					2008
New	Two-story residence with attached garage					2008
New	Two-story residence with attached garage					2008
New	2 story SFR w/ attached garage					2008
New	2 story SFR w/ attached garage					2008
New	Approved Basic 08-100185-BP	Plan No. 1944	2006 IRC	2 story SFR w/attached garage		2008
New	Approved Basic 08-100772-BP		2006 IRC	Plan # 1570-02B	2- Story SFR w/ attach	2008
New	Approved Basic 08-109204-BP	Plan No. 1570-02AB	2006 IRC	2 story SFR w/ attached gara		2008
New	Approved Basic 08-100772-BP		2006 IRC	Plan # 1570-02B	2- Story SFR w/ attach	2008
New	Approved Basic 08-100775-BP		2006 IRC	Plan # 1570-42B	2- Story SFR w/ attach	2008
New	Rambler with daylight basement					2008
New	2-story SFR w/garage					2008
New	2-story SFR w/garage					2008
New	Approved Basic 08-103292-BP	Plan No 2607	2006 IRC	2 story SFR w/ attached garge		2008
New	Approved Basic 08-105709-BP	Plan No. 2280	2006 IRC	2 story SFR w/attached garage		2008
New	Approved Basic 08-103286-BP	Plan No 2744	2006 IRC	2 story SFR w/ attached garage		2008
New	Approved Basic 08-105708-BP	Plan No 2298	2006 IRC	2 story SFR w/ attached g		2008
New	Approved Basic 08-105710-BP	Plan No. 2132	2006 IRC	2 story SFR w/attached garage		2008
New	Two-story w/daylight basement & garage					2008
New	2-story sfr w/attached garage					2008
New	Approved Basic 08-110303-BP	Plan No 2234 B	2006 IRC	2 story SFR w/ attached garage		2008
New	1 story SFR w/ attached garage					2008
New	2-story sfr w/attached garage					2008
New	Two story SFR with attached Garage					2008
New	SENT PERMIT FOLDER TO RECORDS ROOM 12/01/08 DM SFR with Attached Garage					2008
New	Approved Basic 08-108872-BP	Plan No. 1991 A	2006 IRC	2 story SFR w/ attached		2008
New	Approved Basic 08-110302-BP	Plan No 1992	2006 IRC	2 story SFR w/ attached garage		2008
New	Approved Basic 07-114354 BP		2006 IBC		Plan: 1	2008
New	Approved Basic 07-114316 BP		2006 IBC		Plan: 1	2008
New	SENT PERMIT FOLDER TO RECORDS ROOM 12/01/08 DM Approved Basic 07-114321 BP					2008
New	SENT PERMIT FOLDER TO RECORDS ROOM 12/01/08 DM Approved Basic 07-114321 BP					2008
New	SENT PERMIT FOLDER TO RECORDS ROOM 12/01/08 DM Approved Basic 07-114321 BP					2008
New	SENT PERMIT FOLDER TO RECORDS ROOM 12/01/08 DM Approved Basic 07-114316 BP					2008
New	SENT PERMIT FOLDER TO RECORDS ROOM 12/01/08 DM Approved Basic 07-114316 BP					2008
New	Approved Basic 08-108883-BP	Plan No. 2023 A	2006 IRC	2 story SFR w/ attached gara		2008
New	Approved Basic 08-108879-BP	Plan No. 1300 / 2097 B	2006 IRC	Split Level SFR w/ at		2008
New	Approved Basic 08-108874-BP	Plan No. 1348 A	2006 IRC	1 story SFR w/ attached		2008
New	Approved Basic 08-108877-BP	Plan No. 2100 A	2006 IRC	2 story SFR w/attached		2008
New	Approved Basic 08-108884-BP	Plan No. 2023 B	2006 IRC	2 story SFR w/ attache		2008
New	Approved basic 07-108504 BP	2006 IRC	Plan# 2521	2-story sfr w/attached garage		2008
New	Rambler with attached garage					2008
New	Approved Basic 08-106589-BP	Plan No. 2402	2006 IRC	2 story SFR w/ attached gara		2008
New	Approved basic 07-110800 BP	2006 IRC	Plan# 1875	2-story sfr w/attached g		2008
New	2-story SFR w/garage					2008
New	Approved basic 07-110791 BP	2006 IRC	Plan# 2272	2-story sfr w/attached garag		2008
New	Approved basic 07-110789 BP	2006 IRC	Plan# 2537	2-story sfr w/attached garage		2008
New	Approved basic 07-110791 BP	2006 IRC	Plan# 2272	2-story sfr w/attached garag		2008

Accessory Dwelling Units

Index # - File Name: 1.0022 - Single Family Dwellings Data\_Snohomish County.pdf

New	SENT PERMIT FOLDER TO RECORDS ROOM 12/01/08 DM	Two Story SFR w/ attached 3 car gara	2008
New	SENT PERMIT FOLDER TO RECORDS ROOM 12/01/08 DM	Rambler style SFR w/ attached 3 car g	2008
New	Approved Basic 07-108393 BP	2006 IBC Plan: Lopez Two-story residence with attached	2008
New	Approved basic 08-100620 BP	2006 IRC Plan# 621-1D 2-story sfr w/attached gara	2008
New	Approved basic 08-100621 BP	2006 IRC Plan# 623-2D, E 3-story sfr w/attached gar	2008
New	Approved basic 08-100621 BP	2006 IRC Plan# 623-2D, E 3-story sfr w/attached gar	2008
New	Approved basic 08-100620 BP	2006 IRC Plan# 621-1D 2-story sfr w/attached gara	2008
New	Approved basic 08-100620 BP	2006 IRC Plan# 621-1D 2-story sfr w/attached gara	2008
New	Approved basic 08-100621 BP	2006 IRC Plan# 623-2D, E 3-story sfr w/attached gar	2008
New	Approved basic 08-100621 BP	2006 IRC Plan# 623-2D, E 3-story sfr w/attached gar	2008
New	Approved basic 08-100621 BP	2006 IRC Plan# 623-2D, E 3-story sfr w/attached gar	2008
New	Approved basic 08-100621 BP	2006 IRC Plan# 623-2D, E 3-story sfr w/attached gar	2008
New	Approved basic 08-100620 BP	2006 IRC Plan# 621-1D 2-story sfr w/attached gara	2008
New	Approved basic 08-100622 BP	2006 IRC Plan# 624-1D, E, F 2-story sfr w/attache	2008
New	Approved basic 08-100622 BP	2006 IRC Plan# 624-1D, E, F 2-story sfr w/attache	2008
New	Approved basic 08-100622 BP	2006 IRC Plan# 624-1D, E, F 2-story sfr w/attache	2008
New	Approved basic 08-100622 BP	2006 IRC Plan# 624-1D, E, F 2-story sfr w/attache	2008
New	Approved basic 08-100622 BP	2006 IRC Plan# 624-1D, E, F 2-story sfr w/attache	2008
New	Approved basic 08-100624 BP	2006 IRC Plan# 625-2E 2-story sfr w/attached gara	2008
New	1 story SFR w/ unfinished basement and attached garage		2008
New	single family residence		2008
New	SFR Rambler with attached garage		2008
New	2 story SFR w/ attached 3 car garage (4 bedroom plus den & bonus room)		2008
New	Two-story residence		2008
New	Two story SFR with attached Garage		2008
New	Approved Basic 07-113891-BP	Plan No. Anemone 2006 IRC 2 story SFR w/ attached g	2008
New	SENT PERMIT FOLDER TO RECORDS ROOM 11/04/08 DM	Approved Basic 07-113891-BP Plar	2008
New	SENT PERMIT FOLDER TO RECORDS ROOM 11/04/08 DM	Approved Basic 07-113891-BP Plar	2008
New	Approved Basic #07-113358 BP	2006 IRC Plan: Madison B Two Story SFR w/attached garag	2008
New	Approved Basic #07-113358 BP	2006 IRC Plan: Madison B Two Story SFR w/attached garag	2008
New	Two Story SFR with Attached Garage		2008
New	Approved Basic 07-108820-BP	2006 IRC Plan #3028-A1 & A2 2-Story SFR w/attached 2	2008
New	Approved Basic 08-100946 BP	2006 IRC Plan: 2300 Two-story sfr with attache	2008
New	Approved Basic 07-100148 BP	2003 IRC Plan: Crestone Gable B(I)	2008
New	Approved Basic 07-100145 BP	2003 IRC Plan: Langley Hip A(I) T	2008
New	Approved basic 06-134177 BP	2003 IRC Plan# Waterton Gable B (I) 2-story sfr w/attac	2008
New	Approved basic 06-133592 BP	2003 IRC Plan# Shasta Gable 2-story sfr w/attached ga	2008
New	Approved 07-102605 BP	2003 IRC Plan# Glacier Gable B (I) 2-story sfr w/attached	2008
New	Approved Basic 07-104092-BP	2003 IRC Plan # Palisade Gable B(I) 2-story SFR w/ a	2008
New	Approved Basic #07-107866 BP	2003 IRC Plan: Crestone Gable II B (I) Two Story SFR w/atta	2008
New	Approved Basic #07-113358 BP	2006 IRC Plan: Madison B Two Story SFR w/attached garag	2008
New	Rambler with attached garage		2008
New	Rambler with attached garage		2008
New	Approved Basic 08-100946 BP	2006 IRC Plan: 2300 Two-story sfr with attached	2008
New	Two-story residence with attached garage		2008
New	Approved Basic 08-101376-BP	Plan No 2590 2006 IRC 2 story SFR w/ attached garage	2008
New	SFR Rambler with attached garage		2008

Accessory Dwelling Units

Index # - File Name: 1.0022 - Single Family Dwellings Data\_Snohomish County.pdf

New	Approved	Basic # 08-102967 BP	2006 IRC	Plan: Adams B	Two story SFR with Attached Garage	2008
New	Approved	Basic 07-108800-BP	2006	Plan #3012-B	2-Story SFR w/attached garage	2008
New	Approved	basic 07-108262 BP	2006 IRC	Plan# 3027-C	2-story sfr w/attached garage	2008
New	Approved	Basic 07-108807-BP	2006 IRC	Plan # 3915-B	2-Story SFR w/ attached garage	2008
New	Approved	Basic 07-108821-BP	2006 IRC	Plan # 3025-B	2-Story SFR w/ attached garage	2008
New	Approved	basic 07-108259 BP	2006 IRC	Plan# 3026-B	2-story sfr w/attached garage	2008
New	Approved	Basic 07-108820-BP	2006 IRC	Plan #3028-A1 & A2	2-Story SFR w/attached garage	2008
New	Approved	Basic 08-109067-BP	Plan No. 3823-B	2006 IRC	2 story SFR w/ attached garage	2008
New	Approved	Basic 07-108817-BP	2006 IRC	Plan #3024-B	2-Story SFR w/attached garage	2008
New	Approved	Basic 07-108809-BP	2006 IRC	Plan #3019-B	2-Story SFR w/attached garage	2008
New	Approved	Basic 07-108804-BP	2006 IRC	Plan #3914-A	2-Story SFR w/ attached garage	2008
New	Approved	Basic 07-108812-BP	2006 IRC	Plan #3023-A	2-Story SFR w/attached garage	2008
New	Approved	basic 07-108257 BP	2006 IRC	Plan# 3026-A	2-story sfr w/attached garage	2008
New	Approved	Basic 08-109067-BP	Plan No. 3823-B	2006 IRC	2 story SFR w/ attached garage	2008
New	Approved	Basic 07-108820-BP	2006 IRC	Plan #3028-A1 & A2	2-Story SFR w/attached garage	2008
New	Approved	Basic 07-108805-BP	2006 IRC	Plan #3914-B	2-Story SFR w/attached garage	2008
New	Approved	Basic 07-108803-BP	2006 IRC	Plan #3913-B	2-Story SFR w/ attached garage	2008
New	Approved	Basic 07-108804-BP	2006 IRC	Plan #3914-A	2-Story SFR w/ attached garage	2008
New	Approved	Basic 07-108817-BP	2006 IRC	Plan #3024-B	2-Story SFR w/attached garage	2008
New	Approved	Basic 07-108821-BP	2006 IRC	Plan # 3025-B	2-Story SFR w/ attached garage	2008
New	Approved	Basic 07-108808-BP	2006 IRC	Plan #3019-A	2-Story SFR w/attached garage	2008
New	Approved	Basic 07-108817-BP	2006 IRC	Plan #3024-B	2-Story SFR w/attached garage	2008
New	Approved	Basic 07-108807-BP	2006 IRC	Plan # 3915-B	2-Story SFR w/ attached garage	2008
New	Approved	Basic 07-108803-BP	2006 IRC	Plan #3913-B	2-Story SFR w/ attached garage	2008
New	Approved	basic 07-108259 BP	2006 IRC	Plan# 3026-B	2-story sfr w/attached garage	2008
New	Approved	Basic 07-108805-BP	2006 IRC	Plan #3914-B	2-Story SFR w/attached garage	2008
New	Approved	Basic 07-108809-BP	2006 IRC	Plan #3019-B	2-Story SFR w/attached garage	2008
New	Approved	Basic 07-108806-BP	2006 IRC	Plan # 3915-A	2- Story SFR w/ attached garage	2008
New	Approved	Basic 07-108802-BP	2006 IRC	Plan #3913-A	2-Story SFR w/attached garage	2008
New	Approved	Basic 07-108804-BP	2006 IRC	Plan #3914-A	2-Story SFR w/ attached garage	2008
New	Approved	Basic 08-103216-BP	Plan No. 2120-02Bv3	2006 IRC	2 story SFR w/ attached garage	2008
New	Approved	Basic 07-112054-BP	2006 IRC	Plan # AG2100-02A	2-Story SFR w/ attached garage	2008
New	Approved	Basic 08-103215-BP	Plan No. 2120-02Av3	2006 IRC	2 story SFR w/attached garage	2008
New	Approved	Basic 07-112055-BP	2006 IRC	Plan # AG2100-02-B	2-Story SFR w/ attached garage	2008
New	Approved	Basic 07-113805-BP	Plan No. 30021-A2	2006 IRC	2 story sfr w/ attached garage	2008
New	Approved	Basic 07-113806-BP	Plan No. 30011-AB2	2006 IRC	2 story SFR w/ attached garage	2008
New	Approved	Basic 07-113807-BP	Plan No. 30031-AB2	2006 IRC	2 story sfr w/ attached garage	2008
New	Approved	Basic 07-113806-BP	Plan No. 30011-AB2	2006 IRC	2 story SFR w/ attached garage	2008
New		Rambler style SFR w/unfinished basement and garage				2008
New		SENT PERMIT FOLDER TO RECORDS ROOM 11/04/08 DM Approved Basic 07-112803 BP				2008
New		2 story SFR w/ attached garage				2008
New		2 story SFR w/ attached garage				2008
New		2 story SFR w/ attached garage				2008
New		2 story SFR w/ attached garage				2008
New		2 story SFR w/ attached garage				2008
New		2 story SFR w/ attached garage				2008
New	Approved	Basic 07-113776-BP	Plan no. 35052-AB2	2006 IRC	2 story sfr w/ attached garage	2008

Accessory Dwelling Units

Index # - File Name: 1.0022 - Single Family Dwellings Data\_Snohomish County.pdf

New	Approved Basic 07-113776-BP	Plan no. 35052-AB2	2006 IRC	2 story sfr w/ attached garage	2008
New	Approved Basic 07-113776-BP	Plan no. 35052-AB2	2006 IRC	2 story sfr w/ attached garage	2008
New	Approved Basic 07-113776-BP	Plan no. 35052-AB2	2006 IRC	2 story sfr w/ attached garage	2008
New	Approved Basic 07-113807-BP	Plan No. 30031-AB2	2006 IRC	2 story sfr w/ attached	2008
New	Approved Basic 07-112807 BP		2006 IRC	Plan: C505A Two-stor	2008
New	Approved Basic 08-100228-BP	Plan No C405	2006 IRC	2 story SFR w/ attached garage (4	2008
New	Approved Basic 07-112809 BP		2006 IRC	Plan: C505B Two-stor	2008
New	Approved Basic #08-101769 BP	Plan C401x A&B	2006 IRC	2-story w/finished	2008
New	Approved Basic 08-100920-BP	Plan No. C507x A&B	2006 IRC	2 story w/ finished basement	2008
New	Rambler with attached garage				2008
New	Approved Basic 07-111371-BP	2006 IRC	Plan # 2042	2- Story SFR w/ attached ga	2008
New	Approved Basic 07-111371-BP	2006 IRC	Plan # 2042	2- Story SFR w/ attached ga	2008
New	Approved Basic 07-111371-BP	2006 IRC	Plan # 2042	2- Story SFR w/ attached ga	2008
New	Approved Basic 07-111371-BP	2006 IRC	Plan # 2042	2- Story SFR w/ attached ga	2008
New	Approved Basic 07-111371-BP	2006 IRC	Plan # 2042	2- Story SFR w/ attached ga	2008
New	2575 sq ft Rambler with attached Garage				2008
New	two story SFR w/ attached 3 car garage				2008
New	2-story SFR w/garage				2008
New	SFR - rambler w/ bonus room over attached two car garage				2008
New	New 2 story SFR w/ attached garage				2008
New	Approved Basic 07-111859 BP	Plan Number 1388	2006 IRC	1 story w/ lo	2008
New	*Issued under tax roll # 005095-000-019-03*			2 story SFR w/ attached garage	2008
New	Approved Basic 07-112054-BP	2006 IRC	Plan # AG2100-02A	2-Story SFR w/ att	2008
New	Approved Basic 08-103215-BP	Plan No. 2120-02Av3	2006 IRC	2 story SFR w/attached	2008
New	Approved Basic 08-103216-BP	Plan No. 2120-02Bv3	2006 IRC	2 story SFR w/ attached garage	2008
New	Approved Basic 07-112054-BP	2006 IRC	Plan # AG2100-02A	2-Story SFR w/ att	2008
New	Approved Basic 08-103215-BP	Plan No. 2120-02Av3	2006 IRC	2 story SFR w/attached gar	2008
New	Approved Basic 07-112055-BP	2006 IRC	Plan # AG2100-02-B	2-Story SFR w/ ati	2008
New	Approved Basic 08-103216-BP	Plan No. 2120-02Bv3	2006 IRC	2 story SFR w/ attached garage	2008
New	Approved Basic 08-103215-BP	Plan No. 2120-02Av3	2006 IRC	2 story SFR w/attached	2008
New	Approved Basic 07-112055-BP	2006 IRC	Plan # AG2100-02-B	2-Story SFR w/ ati	2008
New	Two story SFR with attached Garage				2008
New	2-story duplex				2008
New	New rambler SFR w/ attached garage				2008
New	Approved basic 07-111257BP	2006 IRC	Plan# 1807	2-story sfr w/attached garag	2008
New	Approved basic 07-111255 BP	2006 IRC	Plan# 1785	2-story sfr w/attached gar	2008
New	Approved basic 07-111255 BP	2006 IRC	Plan# 1785	2-story sfr w/attached gar	2008
New	Approved Basic No. 07-109699 BP	Builder No. 1865-B	2006 IRC	2 story SFR w/ attachec	2008
New	Approved Basic No. 07-109699 BP	Builder No. 1865-B	2006 IRC	2 story SFR w/ attachec	2008
New	Approved basic 07-112026 BP	2006 IRC	Plan# 1339 B	Rambler sfr w/attached ga	2008
New	Approved basic 07-111993 BP	2006 IRC	Plan# 1253	Rambler sfr w/attached garag	2008
New	Approved Basic No. 07-109699 BP	Builder No. 1865-B	2006 IRC	2 story SFR w/ attachec	2008
New	Approved basic 07-112026 BP	2006 IRC	Plan# 1339 B	Rambler sfr w/attached ga	2008
New	Approved basic 07-111993 BP	2006 IRC	Plan# 1253	Rambler sfr w/attached garag	2008
New	SENT PERMIT FOLDER TO RECORDS ROOM 12/01/08 DM	Approved basic 07-112026 BP	2006 IRC		2008
New	Approved basic 07-105280 BP	2006 IRC	Plan# 1493	Rambler w/attached garag	2008
New	Changing size of mobilehome on approved permit 07-110108 MH				2008



Accessory Dwelling Units

Index # - File Name: 1.0022 - Single Family Dwellings Data\_Snohomish County.pdf

New	Approved	Basic 08-100502-BP	Plan: 1571	2006 IRC	1571 sq ft Rambler with Garage	2008
New	Approved	Basic 08-107782-BP	Plan No. 1200	2006 IRC	Rambler w/ attached garage	2008
New	Approved	Basic 08-107542-BP	Plan No. 1786	2006 IRC	Split Level SFR w/ attached garage	2008
New	Two story SFR w/ attached garage					2008
New	Approved	basic 07-105280-BP	2006 IRC	Plan# 1493	Rambler w/attached garage	2008
New	Approved	Basic No. 07-109699-BP	Builder No. 1865-B	2006 IRC	2 story SFR w/ attached garage	2008
New	Approved	Basic No. 07-109699-BP	Builder No. 1865-B	2006 IRC	2 story SFR w/ attached garage	2008
New	Approved	basic 07-112026-BP	2006 IRC	Plan# 1339 B	Rambler sfr w/attached garage	2008
New	Approved	Basic 07-109698-BP	Builder No. 2189-B	2006 IRC	2 story SFR w/ attached 2 or 3 car garage	2008
New	Approved	Basic No. 07-109699-BP	Builder No. 1865-B	2006 IRC	2 story SFR w/ attached garage	2008
New	Approved	Basic 07-109697	Builder No. 1493-B	2006 IRC	2 story SFR w/ attached garage	2008
New	Approved	basic 07-112026-BP	2006 IRC	Plan# 1339 B	Rambler sfr w/attached garage	2008
New	Approved	Basic No. 07-109699-BP	Builder No. 1865-B	2006 IRC	2 story SFR w/ attached garage	2008
New	Approved	basic 07-111993-BP	2006 IRC	Plan# 1253	Rambler sfr w/attached garage	2008
New	Approved	Basic 07-109698-BP	Builder No. 2189-B	2006 IRC	2 story SFR w/ attached 2 or 3 car garage	2008
New	Approved	Basic 08-100987-BP	Plan No. Pebble Beach	2006 IRC	2 story SFR w/ attached garage	2008
New	Approved	Basic 08-100987-BP	Plan No. Pebble Beach	2006 IRC	2 story SFR w/ attached garage	2008
New	Approved	Basic 08-107621-RK	Plan No. 1271	2006 IRC	Rambler SFR w/ attached garage	2008
New	Approved	Basic 08-100185-BP	Plan No. 1944	2006 IRC	2 story SFR w/attached garage	2008
New	Approved	Basic 08-107621-RK	Plan No. 1271	2006 IRC	Rambler SFR w/ attached garage	2008
New	Approved	Basic 08-107782-BP	Plan No. 1200	2006 IRC	Rambler w/ attached garage	2008
New	Approved	Basic 08-107782-BP	Plan No. 1200	2006 IRC	Rambler w/ attached garage	2008
New	Two Story SFR with Finished Basement and Attached Garage					2008
New	Approved	Basic 08-100772-BP	2006 IRC	Plan # 1570-02B	2- Story SFR w/ attached garage	2008
New	Approved	Basic 08-107542-BP	Plan No. 1786	2006 IRC	Split Level SFR w/ attached garage	2008
New	Approved	Basic 08-107621-RK	Plan No. 1271	2006 IRC	Rambler SFR w/ attached garage	2008
New	Approved	Basic 08-100185-BP	Plan No. 1944	2006 IRC	2 story SFR w/attached garage	2008
New	Approved	Basic 08-107542-BP	Plan No. 1786	2006 IRC	Split Level SFR w/ attached garage	2008
New	Approved	Basic 07-108804-BP	2006 IRC	Plan #3914-A	2-Story SFR w/ attached garage	2008
New	27x68, 2008 Karsten					2008
New	2008 27 ft X 70 ft Double-Wide MH					2008
New	2008 Pacifica/Marlette Manufactured Home					2008
New	27x56, 2008 Karsten					2008
New	Rambler style w/garage					2008
New	Approved	Basic 07-114170-BP	Plan 1231A	2006 IRC/IBC	One story SFR w/ attached garage	2008
New	Approved	Basic 08-109067-BP	Plan No. 3823-B	2006 IRC	2 story SFR w/ attached garage	2008
New	Approved	Basic 08-109064-BP	Plan No. 3822-A	2006 IRC	2 story SFR w/ attached garage	2008
New	SFR					2008
New	Approved	Basic 08-100886-BP	Plan No. 3048	2006 IRC	2 story SFR w/attached garage	2008
New	Approved	Basic 08-100887-BP	Plan No 2548	2006 IRC / Perscriptive	1 story w/ 3 car garage	2008
New	Approved	Basic 08-100886-BP	Plan No. 3048	2006 IRC	2 story SFR w/attached garage	2008
New	Approved	Basic 08-100887-BP	Plan No 2548	2006 IRC / Perscriptive	1 story w/ 3 car garage	2008
New	2 story SFR w/ attached 3 car garage					2008
New	Approved	Basic 08-100887-BP	Plan No 2548	2006 IRC / Perscriptive	1 story w/ 3 car garage	2008
New	Approved	Basic 08-104186-BP	Plan No 2870	2006 IRC	2 story SFR w/ attached garage	2008
New	Two Story SFR w/ attached garage					2008
New	2-story Single Family Residence					2008

Accessory Dwelling Units

Index # - File Name: 1.0022 - Single Family Dwellings Data\_Snohomish County.pdf

New	1456 sq ft Rambler				2008
New	Approved Basic 07-109325-BP	2006 IRC	Plan # 2365	Tri-Level SFR w/ attached gara	2008
New	Approved Basic 08-106992-BP	Plan No. 2533-03AB	2006 IRC	2 story SFR w/ attach	2008
New	Approved Basic 08-106999-BP	2788-02AB	2006 IRC	2 story SFR w/ attached garage	2008
New	Approved Basic 08-105360-BP	Plan No. 2357-02Av2	2006 IRC	2 story SFR w/ attached	2008
New	Approved Basic 08-104855-BP	Plan No. 2439 With Bonus Room	2006 IRC	Rambler w/ bi	2008
New	Rambler with attached garage				2008
New	Approved Basic #08-108756 BP	Plan No. Type 1	2006 IRC	2-story Duplex w/ga	2008
New	Approved Basic #08-108756 BP	Plan No. Type 1	2006 IRC	2-story Duplex w/ga	2008
New	Approved Basic #08-108756 BP	Plan No. Type 1	2006 IRC	2-story Duplex w/ga	2008
New	Approved Basic #08-108756 BP	Plan No. Type 1	2006 IRC	2-story Duplex w/ga	2008
New	Approved Basic #08-108756 BP	Plan No. Type 1	2006 IRC	2-story Duplex w/ga	2008
New	Approved Basic #08-108756 BP	Plan No. Type 1	2006 IRC	2-story Duplex w/ga	2008
New	Approved Basic #08-108756 BP	Plan No. Type 1	2006 IRC	2-story Duplex w/ga	2008
New	Approved Basic #08-108756 BP	Plan No. Type 1	2006 IRC	2-story Duplex w/ga	2008
New	SENT PERMIT FOLDER TO RECORDS ROOM 11/04/08 DM	Approved basic 07-110393 BP	2006		2008
New	Approved basic 07-110387 BP	2006 IRC	Plan# 1649	Ramber style sfr w/attache	2008
New	Approved basic 07-110387 BP	2006 IRC	Plan# 1649	Ramber style sfr w/attache	2008
New	SENT PERMIT FOLDER TO RECORDS ROOM 12/01/08 DM	Rambler style sfr w/attached garage			2008
New	SENT PERMIT FOLDER TO RECORDS ROOM 11/04/08 DM	Approved basic 07-110393 BP	2006		2008
New	Approved basic 07-110397 BP	2006 IRC	Plan# 2098	Rambler w/daylight basement attch	2008
New	Approved basic 07-110387 BP	2006 IRC	Plan# 1649	Ramber style sfr w/attache	2008
New	Approved basic 07-110387 BP	2006 IRC	Plan# 1649	Ramber style sfr w/attache	2008
New	Approved basic 07-110397 BP	2006 IRC	Plan# 2098	Rambler w/daylight basement attch	2008
New	SENT PERMIT FOLDER TO RECORDS ROOM 11/04/08 DM	Approved basic 07-110393 BP	2006		2008
New	SENT PERMIT FOLDER TO RECORDS ROOM 11/04/08 DM	Approved basic 07-110397 BP	2006		2008
New	SENT PERMIT FOLDER TO RECORDS ROOM 11/04/08 DM	Approved basic 07-110397 BP	2006		2008
New	Two story SFR with attached Garage				2008
New	2006 Fleetwood Americana Mobile Home				2008
New	Approved Basic 08-105673-BP	Plan No 1870 / 1840	2006 IRC	2 story DUPLEX w/ attache	2008
New	Approved Basic 07-109336-BP	2006 IRC	Plan # 2352.1	2-Story SFR w/ attached	2008
New	2 story SFR w/ attached garage and unfinished storage.	07=114859, 07114788FZ.			2008
New	Approved Basic 07-114816-BP	Plan No 2084	2006 IRC/IBC	2 story SFR w/	2008
New	Approved Basic 07-114816-BP	Plan No 2084	2006 IRC/IBC	2 story SFR w/	2008
New	Approved Basic 07-114816-BP	Plan No 2084	2006 IRC/IBC	2 story SFR w/	2008
New	Approved Basic 07-114816-BP	Plan No 2084	2006 IRC/IBC	2 story SFR w/	2008
New	SENT PERMIT FOLDER TO RECORDS ROOM 11/24/08 DM	Approved Basic #06-129185 BP	2006		2008
New	Rambler style SFR				2008
New	Approved Basic 07-111814-BP	Plan No 2734 A	2006 IRC	2 story SFR w/ attached g	2008
New	Approved Basic #07-113367 BP	2006 IRC	Plan: Shasta B	Two Story SFR w/attached gara	2008
New	Approved Basic 07-111790-BP	Plan No. 2440A - EF	2006 IRC	2 story SFR w/ Attached g	2008
New	Approved Basic #07-113367 BP	2006 IRC	Plan: Shasta B	Two Story SFR w/attached gara	2008
New	Approved Basic 07-111784-BP	Plan No. 2140 A	2006 IRC	2 story SFR w Attached G	2008
New	Approved Basic #07-113355 BP	2006 IRC	Plan: Langley II A	Two Story SFR w/attached gara	2008
New	Approved Basic #07-113368 BP	2006 IRC	Plan: Tyndall A	Two Story SFR w/attached gara	2008
New	Approved Basic #07-113344 BP	2006 IRC	Plan: Appleton B	Two Story SFR w/attached gara	2008
New	Approved Basic 07-111814-BP	Plan No 2734 A	2006 IRC	2 story SFR w/ attached g	2008

Accessory Dwelling Units

Index # - File Name: 1.0022 - Single Family Dwellings Data\_Snohomish County.pdf

New	Approved Basic #07-113357 BP	2006 IRC	Plan: Madison A	Two Story SFR w/attached garage	2008
New	Approved Basic #07-113364 BP	2006 IRC	Plan: Palisade B	Two Story SFR w/attached garage	2008
New	Approved Basic #07-113358 BP	2006 IRC	Plan: Madison B	Two Story SFR w/attached garage	2008
New	Approved Basic #07-113369 BP	2006 IRC	Plan: Tyndall B	Two Story SFR w/attached garage	2008
New	Approved Basic #07-113347 BP	2006 IRC	Plan: Crestone II A	Two Story SFR w/attached garage	2008
New	Approved Basic #07-113358 BP	2006 IRC	Plan: Madison B	Two Story SFR w/attached garage	2008
New	Approved Basic #07-113348 BP	2006 IRC	Plan: Crestone II B	Two Story SFR w/attached garage	2008
New	Approved Basic #07-113357 BP	2006 IRC	Plan: Madison A	Two Story SFR w/attached garage	2008
New	Approved Basic #07-113367 BP	2006 IRC	Plan: Shasta B	Two Story SFR w/attached garage	2008
New	Approved Basic #07-113363 BP	2006 IRC	Plan: Palisade A	Two Story SFR w/attached garage	2008
New	Approved Basic #07-113357 BP	2006 IRC	Plan: Madison A	Two Story SFR w/attached garage	2008
New	Approved Basic #07-113358 BP	2006 IRC	Plan: Madison B	Two Story SFR w/attached garage	2008
New	Approved Basic #07-113364 BP	2006 IRC	Plan: Palisade B	Two Story SFR w/attached garage	2008
New	Approved Basic #07-113367 BP	2006 IRC	Plan: Shasta B	Two Story SFR w/attached garage	2008
New	Approved Basic 07-111814-BP	Plan No 2734 A	2006 IRC	2 story SFR w/ attached garage	2008
New	Approved Basic 08-15626-BP	Plan:T2472-02A-N	2006 IRC	2-story SFR w/garage	2008
New	Approved BASIC: 07-108415-BP	Builder s Plan No. 3117A	2006 IRC	2 Story SFR w/ attached garage	2008
New	Approved Basic 08-104586-BP	Plan No. 2598 AB	2006 IRC	2 story sfr w/ attached 3 car garage	2008
New	Approved Basic #07-113355 BP	2006 IRC	Plan: Langley II A	Two Story SFR w/attached garage	2008
New	Approved Basic 05-100006BP	2003 IRC	Plan:2472A	2 story SFR w/attached garage	2008
New	Approved BASIC: 07-108415-BP	Builder s Plan No. 3117A	2006 IRC	2 Story SFR w/ attached garage	2008
New	Approved Basic 07-111814-BP	Plan No 2734 A	2006 IRC	2 story SFR w/ attached garage	2008
New	Approved Basic 05-100008BP	2 story SFR w/attached garage	2003 IRC	Plan:2472B	2008
New	Approved Basic 07-111794	Plan No. 2472 A	2006 IRC	2 story SFR w/attached garage	2008
New	Two story SFR w/ attached garage				2008
New	2 story SFR w/ attached garage and unfinished basement				2008
New	SENT PERMIT FOLDER TO RECORDS ROOM 10/23/08 DM			2-story sfr w/attached garage	2008
New	SENT PERMIT FOLDER TO RECORDS ROOM 10/23/08 DM			2-story sfr w/attached garage	2008
New	Approved Basic 08-105208-BP	Plan No. 1892-1	2006 IRC	2 story SFR w/attached garage	2008
New	Approved Basic 08-105625-BP	Plan No. 1714	2006 IRC	2 story SFR w/attached garage	2008
New	Approved Basic 08-104302-BP	Plan No. 1892	2006 IRC	2 story SFR w/ attached garage	2008
New	Approved Basic 08-105207-BP	Plan No 1722-1	2006 IRC	2 story SFR w/attached garage	2008
New	Approved Basic 08-104302-BP	Plan No. 1892	2006 IRC	2 story SFR w/ attached garage	2008
New	Approved Basic 08-105208-BP	Plan No. 1892-1	2006 IRC	2 story SFR w/attached garage	2008
New	Approved Basic 08-103811	Plan No. 1722	2006 IRC	2 story SFR w/attached garage	2008
New	Approved Basic 08-105208-BP	Plan No. 1892-1	2006 IRC	2 story SFR w/attached garage	2008
New	Approved Basic 08-103811	Plan No. 1722	2006 IRC	2 story SFR w/attached garage	2008
New	2 story SFR w/ attached garage				2008
New	2-story SFR w/garage				2008
New	Transfer of ownership: Notarized copy of Affidavits of Building Permit/Plans Transfer to John &				2008
New	Approved Basic 07-110567-BP	Builder No. 1418C	2006 IRC / WSEC	2 story SFR w/ attached garage	2008
New	Approved Basic 08-100794-BP	Plan No 1727 A	2006 IRC	two story cottage - no garage	2008
New	Approved Basic 07-110121-BP	2006 IRC	Plan # 1418 A	2-Story SFR w/ attached garage	2008
New	Approved Basic 07-111150-BP	2006 IRC	Plan # 1127 C	2- Story SFR w/ attached garage	2008
New	Approved Basic 07-110123-BP	2006 IRC	Plan # 1117 B	2-Story SFR w/ attached garage	2008
New	Approved Basic 07-110565-BP	Builder No. 1428B	2006 IRC	2 story SFR	2008
New	Approved Basic 07-111716-BP	Plan No. 1318 A	2006 IRC / IBC	2 story SFR w attached 1 car garage	2008

Accessory Dwelling Units

Index # - File Name: 1.0022 - Single Family Dwellings Data\_Snohomish County.pdf

New	Approved Basic 07-109361-BP	Builder No. 1318 C	2006 IRC/WSEC	2 story SFR w/	2008
New	Approved basic 07-110754 BP	2006 IRC	Plan# 1137 A	2-story sfr w/attached g	2008
New	Approved Basic 08-100794-BP	Plan No 1727 A	2006 IRC	two story cottage - no garage	2008
New	Approved Basic 07-109671-BP	Builder No. 1418 B	2006 IRC / WSEC	2 story SFR w/ attach	2008
New	Approved Basic 08-100068-BP	Plan No 1721 C	2006 IRC	2 story SFR w/ attached garage	2008
New	Approved Basic 08-100795-BP	Plan No. 1727 B	2006 IRC	2 story cottage - no garage	2008
New	Approved Basic 08-100927-BP	Plan No. 1328 A	2006 IRC	2 story Cottage - no garage	2008
New	Approved Basic 07-110363-BP	Plan No. 1027 A	2006 IBC/IRC	2 story cottage -no garage	2008
New	SENT PERMIT FOLDER TO RECORDS ROOM 10/23/08 DM *Issued under tax roll # 270516-002-0				2008
New	SENT PERMIT FOLDER TO RECORDS ROOM 10/23/08 DM *Issued under tax roll # 270516-002-0				2008
New	SFR Rambler w/ attached 3 car garage				2008
New	Approved Basic 08-100013-BP	Plan No 1721 C	2006 IRC	Two story SFR w/ attached 2 or 3 c	2008
New	Approved Basic 07-109697	Builder No. 1493-B	2006 IRC	2 story SFR w/ attached garage	2008
New	Approved Basic No. 07-109699 BP	Builder No. 1865-B	2006 IRC	2 story SFR w/ attached	2008
New	Approved Basic 07-109698-BP	Builder No. 2189-B	2006 IRC	2 story SFR w/ attached 2 or 3 c	2008
New	Approved Basic No. 07-109699 BP	Builder No. 1865-B	2006 IRC	2 story SFR w/ attached	2008
New	Approved Basic 07-109698-BP	Builder No. 2189-B	2006 IRC	2 story SFR w/ attached 2 or 3 c	2008
New	Approved Basic 07-109698-BP	Builder No. 2189-B	2006 IRC	2 story SFR w/ attached 2 or 3 c	2008
New	Approved Basic 07-109698-BP	Builder No. 2189-B	2006 IRC	2 story SFR w/ attached 2 or 3 c	2008
New	Approved Basic 08-101701-BP	Plan No 2100	2006 IRC	2 story SFR w/ attached garage	2008
New	Approved Basic 08-101701-BP	Plan No 2100	2006 IRC	2 story SFR w/ attached garage	2008
New	Approved Basic 08-101701-BP	Plan No 2100	2006 IRC	2 story SFR w/ attached garage	2008
New	Approved basic 06-132143 BP	2003 IRC	Plan # 2482	2-story sfr w/attached garage	2008
New	Approved Basic 08-101701-BP	Plan No 2100	2006 IRC	2 story SFR w/ attached garage	2008
New	Approved Basic 08-101701-BP	Plan No 2100	2006 IRC	2 story SFR w/ attached garage	2008
New	Approved Basic 08-101701-BP	Plan No 2100	2006 IRC	2 story SFR w/ attached garage	2008
New	Approved basic 06-132143 BP	2003 IRC	Plan # 2482	2-story sfr w/attached garage	2008
New	SENT PERMIT FOLDER TO RECORDS ROOM 11/24/08 DM Approved basic 06-132144 BP 200				2008
New	Approved basic 06-132143 BP	2003 IRC	Plan # 2482	2-story sfr w/attached garage	2008
New	Approved Basic 08-101701-BP	Plan No 2100	2006 IRC	2 story SFR w/ attached garage	2008
New	2007 40 ft X 60 ft Double-wide MH				2008
New	Approved Basic 08-108306 BP		2006 IBC	Plan: 18:	2008
New	Approved Basic 07-108876-BP	Builder No 5	2006 IRC	2 Story SFR w/ attached garage	2008
New	2007 26 ft 8in X 56 ft Double-wide Mobilehome				2008
New	Approved Basic 08-100147-BP	Plan No. 3101 C	2006 IRC	2 story SFR w/ attached gar	2008
New	Approved Basic 07-114382-BP	Plan No 2001 A	2006 IRC	2 story SFR w/ attached garage	2008
New	Approved Basic 07-113575-BP	Plan No. 2202 B	2006 IRC	2 story SFR w/ attached gara	2008
New	Approved Basic 07-113851-BP	Plan No. 2702 A	2006 IRC	2 story SFR w/attached garage	2008
New	Approved Basic 07-113305-BP	Plan No. 2401 C	2006 IRC	2 story SFR w/ attached garage	2008
New	Approved Basic 08-100156	Plan No 3502 C	2006 IRC	Two story sfr w/ attached garage	2008
New	Pending Basic 07-114848-BP	Plan No. 2501 B	2006 IRC	two stroy SFR w/attached ga	2008
New	Approved Basic 07-113305-BP	Plan No. 2401 C	2006 IRC	2 story SFR w/ attached garage	2008
New	SENT PERMIT FOLDER TO RECORDS ROOM 10/23/08 DM Approved basic 06-131596 BP 2				2008
New	SENT PERMIT FOLDER TO RECORDS ROOM 10/23/08 DM Approved basic 06-130553 BP 200				2008
New	SENT PERMIT FOLDER TO RECORDS ROOM 10/23/08 DM Approved basic 06-131596 BP 2				2008
New	Two story SFR with attached Garage				2008
New	SENT PERMIT FOLDER TO RECORDS ROOM 10/23/08 DM Approved basic 06-130541 BP 200				2008

Accessory Dwelling Units

Index # - File Name: 1.0022 - Single Family Dwellings Data\_Snohomish County.pdf

New	SENT PERMIT FOLDER TO RECORDS ROOM 10/23/08 DM	2-story SFR w/garage	2008
New	SENT PERMIT FOLDER TO RECORDS ROOM 10/23/08 DM	Two-story residence w/attached garage	2008
New	SENT PERMIT FOLDER TO RECORDS ROOM 10/23/08 DM	Approved basic 06-131596 BP	2008
New	1721 sq ft single family residence; 852 sq ft second story with attached 390 square foot garage		2008
New	Approved Basic 08-105360-BP	Plan No. 2357-02Av2 2006 IRC 2 story SFR w/ attached	2008
New	Approved Basic 08-103216-BP	Plan No. 2120-02Bv3 2006 IRC 2 story SFR w/ attached garage	2008
New	Approved Basic 08-105361-BP	Plan No 2245-02Av2 2006 IRC 2 story SFR w/attached garage	2008
New	Approved Basic 07-112055-BP	2006 IRC Plan # AG2100-02-B 2-Story SFR w/ attached	2008
New	Approved Basic 08-106996-BP	Plan No. 2368-03AB 2006 IRC 3 story SFR w/ 1st story garage	2008
New	Approved Basic 08-106996-BP	Plan No. 2368-03AB 2006 IRC 3 story SFR w/ 1st story garage	2008
New	SFR rambler with attached garage and second story semi-finished over garage		2008
New	Approved Basic 07-108391 BP	2006 IRC Plan: Type D 2-story sfr w/attached garage	2008
New	New 2 story SFR w/attached garage		2008
New	one story SFR w/ attached garage and attached carport		2008
New	SFR w/ attached garage		2008
New	Approved Basic # 07-1109743 BP	2006 IRC Plan: Nadine Two story SFR with attached Garage	2008
New	2 story SFR w/ attached 4 car garage		2008
New	SENT PERMIT FOLDER TO RECORDS ROOM 12/01/08 DM	2 story SFR w/ attached 4 car garage	2008
New	2 story SFR with attached garage		2008
New	2-story SFR w/garage		2008
New	Approved basic # 07-108468 BP	2006 IRC Plan # 2747 2 story SFR w/ attached 2 car garage	2008
New	Approved basic # 07-108468 BP	2006 IRC Plan # 2747 2 story SFR w/ attached 2 car garage	2008
New	Approved Basic 08-103190 BP	2006 IBC Plan #2597 Two-story residence	2008
New	Approved Basic 07-101625-BP	2003 IRC Plan #1935B 2-story sfr w/ attached garage	2008
New	Approved Basic 07-101619-BP	2003 IRC Plan #1825A 2-story sfr w/ attached garage	2008
New	Approved Basic 07-101612-BP	2003 IRC Plan #1507A 2-story sfr w/ attached garage	2008
New	Approved Basic 07-101624-BP	2003 IRC Plan #1935A 2-story sfr w/ attached garage	2008
New	Approved Basic 08-103374	Plan No. Summerlin 2006 IRC 2 story SFR w/attached garage	2008
New	Approved Basic 08-103374	Plan No. Summerlin 2006 IRC 2 story SFR w/attached garage	2008
New	Approved Basic 06-136125 BP -	2003 IRC Two story SFR with attached Garage Plan: Summerlin	2008
New	Approved Basic 08-103375-BP	Plan No. Bridgeport 2006 IRC 2 story SFR w/attached garage	2008
New	Approved Basic 08-105539 BP	2006 IBC Plan: Summerlin	2008
New	Approved Basic 06-136125 BP -	2003 IRC Two story SFR with attached Garage Plan: Summerlin	2008
New	2 story SFR w/ attached garage		2008
New	2-Story SFR w/attached garage.		2008
New	1854 SFR Rambler w/ attached garage		2008
New	Approved basic 07-111958 BP	2006 IRC Plan# 2338 2-story sfr w/attached garage	2008
New	Approved Basic 08-102973-BP	Plan No. 1646 2006 IRC 2 Story SFR w/ attached garage	2008
New	Two story SFR with attached Garage		2008
New	Approved Basic 08-102875-BP	Plan No 1748 2006 IRC 2 story SFR w/ attached garage	2008
New	Approved Basic 08-102875-BP	Plan No 1748 2006 IRC 2 story SFR w/ attached garage	2008
New	Approved Basic 07-108813-BP	2006 IRC Plan 3023-B 2-Story SFR w/attached garage	2008
New	Approved Basic 08-102871-BP	Plan No. 1602 2006 IRC 2 story SFR w/ attached garage	2008
New	Approved Basic 08-109066-BP	Plan No. 3823-A 2006 IRC 2nd story SFR w/ attached garage	2008
New	Approved Basic 07-108806-BP	2006 IRC Plan # 3915-A 2- Story SFR w/ attached garage	2008
New	Approved Basic 07-108815-BP	2006 IRC Plan #3023 Bonus-B 2-Story SFR w/attached garage	2008
New	Approved Basic 07-108814-BP	1006 IRC Plan #3023 Bonus-A 2-Story SFR w/attached garage	2008

Accessory Dwelling Units

Index # - File Name: 1.0022 - Single Family Dwellings Data\_Snohomish County.pdf

New	Approved Basic 07-108820-BP	2006 IRC	Plan #3028-A1 & A2	2-Story SFR w/attached garage	2008
New	Approved Basic 07-108817-BP	2006 IRC	Plan #3024-B	2-Story SFR w/attached garage	2008
New	Approved basic 07-108279 BP	2006 IRC	Plan# 4111-A	2-story sfr w/ attached garage	2008
New	Approved Basic 07-108807-BP	2006 IRC	Plan # 3915-B	2-Story SFR w/ attached garage	2008
New	Approved Basic 07-108816-BP	2006 IRC	Plan #3024-A	2-Story SFR w/attached garage	2008
New	Approved basic 07-106996 BP	2006 IRC	Plan# 2243 B	2-story sfr w/attached garage	2008
New	SENT PERMIT FOLDER TO RECORDS ROOM 11/04/08 DM Approved basic 07-110023 BP				2008
New	Approved Basic 08-103546-BP	Plan No 2422 A	2006 IRC	2 story SFR w/ attached garage	2008
New	Approved Basic 07-108816-BP	2006 IRC	Plan #3024-A	2-Story SFR w/attached garage	2008
New	Approved Basic 08-103686-BP	Plan No 2422A	2006 IRC	2 story SFR w/attached garage	2008
New	Approved Basic 08-103686-53	Plan No. 2422A	2006 IRC	2 story SFR w/ attached garage	2008
New	Approved Basic 08-103283-BP	Plan No 2751 A	2006 IRC	2 story SFR w/ attached garage	2008
New	Approved Basic 08-103688 BP	Plan No 2751B	2006 IBC	Two-story residence with attached garage	2008
New	SENT PERMIT FOLDER TO RECORDS ROOM 11/04/08 DM Approved Basic 07-110471-BP				2008
New	Approved Basic 07-109288-BP	2006 IRC	Plan # 2243A	2-Story SFR w/ attached garage	2008
New	Approved Basic 08-103546-BP	Plan No 2422 A	2006 IRC	2 story SFR w/ attached garage	2008
New	Approved Basic 08-103688 BP	Plan No 2751B	2006 IBC	Two-story residence with attached garage	2008
New	Approved Basic 07-109288-BP	2006 IRC	Plan # 2243A	2-Story SFR w/ attached garage	2008
New	SENT PERMIT FOLDER TO RECORDS ROOM 11/04/08 DM Approved basic 07-106996 BP				2008
New	Approved Basic 08-103546-BP	Plan No 2422 A	2006 IRC	2 story SFR w/ attached garage	2008
New	2-story sfr w/attached garage				2008
New	Approved Basic 08-107419 BP		2006 IBC	Plan: 2103	2008
New	2-story w/garage				2008
New	Two Story SFR W/attached garage				2008
New	Approved Basic 07-113565 BP	Plan No. 439-2A,B	2006 IRC		2008
New	Approved Basic 07-113565 BP		2006 IRC	Plan: 498-	2008
New	Approved Basic 07-113144 BP		2006 IRC	Plan: 496-2A,B,C	2008
New	SENT PERMIT FOLDER TO RECORDS ROOM 11/04/08 DM Approved Basic 07-113565 BP				2008
New	Approved Basic 07-113144 BP		2006 IRC	Plan: 496-2A,B,C	2008
New	2-story SFR w/garage				2008
New	Approved Basic Two Story SFR with Attached Garage		2006 IRC/IBC	Plan 497-2A,2B,2C	2008
New	Approved Basic 08-101606-BP	Plan No. 411BT-2	2006 IRC	2 story SFR w/ attached garage	2008
New	Approved Basic Two Story SFR with Attached Garage		2006 IRC/IBC	Plan 497-2A,2B,2C	2008
New	Approved Basic 07-113146 BP	Plan No. 435-2A,B,C	2006 IRC /IBC		2008
New	Approved Basic 07-113443- BP	Plan 437-2A,B,C	2006 IRC/IBC	2 story SFR w/attached garage	2008
New	Approved Basic 07-113565 BP	Plan No. 439-2A,B	2006 IRC		2008
New	Approved Basic 07-113443- BP	Plan 437-2A,B,C	2006 IRC/IBC	2 story SFR w/attached garage	2008
New	Approved Basic 08-106327-BP	Plan No. 494-2B,C	2006 IRC	2 story SFR w/ attached garage	2008
New	Approved Basic 07-113146 BP	Plan No. 435-2A,B,C	2006 IRC /IBC		2008
New	Approved Basic 07-113443- BP	Plan 437-2A,B,C	2006 IRC/IBC	2 story SFR w/attached garage	2008
New	Approved Basic 07-110148 BP	Plan 3200A	2006 IRC	2 story SFR w/ attached garage	2008
New	Approved Basic 07-110147 BP	2006 IRC	Plan: 3016B	2-story sfr w/attached garage	2008
New	Approved Basic 07-110857-BP	2006 IRC	Plan # 2996 A	2-Story SFR w/ attached garage	2008
New	Approved Basic 07-110149 BP	Plan No 3016A	2006 IRC	2 story SFR w/ attached garage	2008
New	Approved Basic 07-110856-BP	Plan 2996B	2006 IRC	2 story SFR w/ attached garage	2008
New	Approved basic 07-110369 BP	2006 IRC	Plan# 2658 B	2-story sfr w/attached two car garage	2008
New	Approved Basic 07-110149 BP		2006 IRC	Plan: 3016A Two-story SFR w/attached garage	2008

Accessory Dwelling Units

Index # - File Name: 1.0022 - Single Family Dwellings Data\_Snohomish County.pdf

New	Approved basic 07-110369 BP	2006 IRC	Plan# 2658 B	2-story sfr w/attached two ca	2008
New	Approved Basic 07-110857-BP	2006 IRC	Plan # 2996 A	2-Story SFR w/ attached g	2008
New	Approved Basic 07-110148 BP		2006 IRC	Plan: 3200A Two-str	2008
New	Approved Basic 07-110149 BP		2006 IRC	Plan: 3016A Two-str	2008
New	Approved Basic 07-110858-BP	2006 IRC	Plan # 3200 B	2-Story SFR w/attached g	2008
New	Approved Basic 07-110856-BP	2006 IRC	Plan #2996B	2-Story SFR w/ attached	2008
New	Approved Basic 07-110147 BP	2006 IRC	Plan: 3016B	2-story sfr w/attached garage	2008
New	Approved Basic 07-110367 BP	2006 IRC	Plan: 2658A	2-story sfr w/attached gara	2008
New	Approved Basic 07-110147 BP	2006 IRC	Plan: 3016B	2-story sfr w/attached garage	2008
New	Approved Basic 07-110367 BP	2006 IRC	Plan: 2658A	2-story sfr w/attached gara	2008
New	Approved Basic 07-110147 BP	2006 IRC	Plan: 3016B	2-story sfr w/attached garage	2008
New	Approved Basic 07-110148 BP		2006 IRC	Plan: 3200A Two-str	2008
New	Approved Basic #07-110534BP	2006 IRC	Plan:3216A	2 story SFR	2008
New	Approved Basic #07-110533	2006 IRC	Plan:3154 A & B	2 story SFR	2008
New	Approved Basic #07-110533	2006 IRC	Plan:3154 A & B	2 story SFR	2008
New	Approved Basic #07-110533	2006 IRC	Plan:3154 A & B	2 story SFR	2008
New	Approved Basic 07-114384-BP	Plan No. 2001 C	2006 IRC	2 story SFR w/attached garage	2008
New	Approved Basic 07-114382-BP	Plan No 2001 A	2006 IRC	2 story SFR w/ attached garage	2008
New	Approved Basic 07-114382-BP	Plan No 2001 A	2006 IRC	2 story SFR w/ attached garage	2008
New	Approved Basic 07-113305-BP	Plan No. 2401 C	2006 IRC	2 story SFR w/ attached garage	2008
New	Approved Basic 07-113303-BP	Plan No. 2401 B	2006 IRC	2 story SFR w/ attached gara	2008
New	Approved Basic 07-114391-BP	Plan No 2811 C	2006 IRC	2 story SFR w/ attached garage	2008
New	Approved Basic 08-100377-BP	Plan No. 2841 B	2006 IRC	2 story SFR w/ attachcd 3 car garage	2008
New	Approved Basic 07-113884-BP	Plan No. 2002 C	2006 IRC	2 story SFR w/ attached garage	2008
New	Approved Basic 08-100142-BP	Plan No. 2741 B	2006 IRC	2 story SFR w/ attached 2 or	2008
New	Approved Basic 07-114382-BP	Plan No 2001 A	2006 IRC	2 story SFR w/ attached garage	2008
New	Approved Basic 07-113305-BP	Plan No. 2401 C	2006 IRC	2 story SFR w/ attached garage	2008
New	Approved Basic 07-113570-BP	Plan No 2201 A	2006 IRC	2 story SFR w/ attached garag	2008
New	Approved Basic 07-114383-BP	Plan No. 2001 B	2006 IRC	2 story SFR w/ attached garage	2008
New	Approved Basic 07-114382-BP	Plan No 2001 A	2006 IRC	2 story SFR w/ attached garage	2008
New	Approved Basic 07-114841-BP	Plan No 2101 A	2006 IRC	two stroy SFR w/attached gara	2008
New	Approved Basic 07-109668-BP	Builder No. 3131 B	2006 IRC / WSEC	2 story SFR w/ attach	2008
New	Approved Basic 07-113327-BP	Plan No. 2802 B	2006 IRC	2 story SFR w/ attached garage	2008
New	Approved Basic 07-114384-BP	Plan No. 2001 C	2006 IRC	2 story SFR w/attached garage	2008
New	Approved Basic 07-114844-BP	Plan No 2102 A	2006 IRC	two stroy SFR w/attached gara	2008
New	Approved Basic 07-113570-BP	Plan No 2201 A	2006 IRC	2 story SFR w/ attached garag	2008
New	Approved Basic 07-113882-BP	Plan No. 2002 A	2006 IRC	2 story SFR w/ attached garage	2008
New	Approved Basic 07-113012	Builder Plan No 2722	2006 IRC	One story SFR w/	2008
New	Approved Basic #07-107425 BP	2006 IRC	Plan: 2400	Rambler Style SFR w/attached gara	2008
New	2-story w/garage and deck				2008
New	Approved Basic 07-113443- BP	Plan 437-2A,B,C	2006 IRC/IBC	2 story SFR w/attached g	2008
New	Approved Basic 07-113146 BP	Plan No. 435-2A,B,C	2006 IRC /IBC		2008
New	Approved Basic 07-113443- BP	Plan 437-2A,B,C	2006 IRC/IBC	2 story SFR w/attached g	2008
New	Approved Basic 07-113146 BP	Plan No. 435-2A,B,C	2006 IRC /IBC		2008
New	Approved Basic 08-101606-BP	Plan No. 411BT-2	2006 IRC	2 story SFR w/ attached garage	2008
New	Approved Basic 07-113443-BP	Plan No. 497-2A,2B,2C	2006 IRC	2 story SFR w/ attache	2008
New	two story Duplex w/ attached garage				2008

Accessory Dwelling Units

Index # - File Name: 1.0022 - Single Family Dwellings Data\_Snohomish County.pdf

New	two story Duplex w/ attached garage				2008
New	2 story SFR w/attached garage				2008
New	2-story sfr w/attached garage				2008
New	2 story sfr w/attached garage				2008
New	Two story SFR with attached Garage				2008
New	Approved Basic 08-100393-BP	2006 IRC	Plan # 1742	2-Story SFR w/ attached 2 car	2008
New	Approved Basic 08-100147-BP	Plan No. 3101 C	2006 IRC	2 story SFR w/ attached gar	2008
New	Approved Basic 07-113570-BP	Plan No 2201 A	2006 IRC	2 story SFR w/ attached garag	2008
New	Approved Basic 07-113305-BP	Plan No. 2401 C	2006 IRC	2 story SFR w/ attached garage	2008
New	Approved Basic 07-113309-BP	Plan No. 2402 C	2006 IRC	2 story SFR w/ attached garag	2008
New	Two-story residence with daylight basement and attached garage				2008
New	2 story SFR with basement & attached garage				2008
New	2-story w/garage				2008
New	Two story Duplex with attached Garages				2008
New	Two story Duplex with attached Garages				2008
New	Approved Basic 08-100393-BP	2006 IRC	Plan # 1742	2-Story SFR w/ attached 2 car	2008
New	SENT PERMIT FOLDER TO RECORDS ROOM 10/27/08 DM Approved basic 06-133783 BP				2003
New	Residence above garage				2008
New	To final Expired 05-126877 RK, construction already done				2008
New	Approved Basic 08-100189-RK	Plan no 1944	2006 IRC	2 story SFR w/ attached garage	2008
New	Approved Basic 08-100189-RK	Plan no 1944	2006 IRC	2 story SFR w/ attached garage	2008
New	Approved Basic 08-100189-RK	Plan no 1944	2006 IRC	2 story SFR w/ attached garage	2008
New	Approved Basic 08-100189-RK	Plan no 1944	2006 IRC	2 story SFR w/ attached garage	2008
New	Approved Basic 08-100189-RK	Plan no 1944	2006 IRC	2 story SFR w/ attached garage	2008
New	Approved Basic 08-100186 BP	Plan No 2137	2006 IRC	2 story SFR w/ attached gar	2008
New	Approved Basic 08-100186 BP	Plan No 2137	2006 IRC	2 story SFR w/ attached ga	2008
New	Approved Basic 08-100186 BP	Plan No 2137	2006 IRC	2 story SFR w/ attached ga	2008
New	Approved Basic 08-100186 BP	Plan No 2137	2006 IRC	2 story SFR w/ attached ga	2008
New	Approved Basic 08-100186 BP	Plan No 2137	2006 IRC	2 story SFR w/ attached gar	2008
New	Approved Basic 08-100189-RK	Plan no 1944	2006 IRC	2 story SFR w/ attached garage	2008
New	Approved Basic 08-100186 BP	Plan No 2137	2006 IRC	2 story SFR w/ attached gar	2008
New	Approved Basic 08-100185BP	Plan no 1944	2006 IRC	2 story SFR w/ attached garage	2008
New	Approved Basic 08-100185-BP	Plan no 1944	2006 IRC	2 story SFR w/ attached garage	2008
New	Approved Basic 08-100186 BP	Plan No 2137	2006 IRC	2 story SFR w/ attached gar	2008
New	Proposed 440 sq ft detached accessory apartment within a proposed 1056 sq ft detached garag				2008
New	2-story Single Family Residence w/garage and covered deck				2008
New	SENT PERMIT FOLDER TO RECORDS ROOM 12/01/08 DM Two-story residence				2008
New	SENT PERMIT FOLDER TO RECORDS ROOM 10/27/08 DM Two-story residence				2008
New	60x40, 2008 Karsten Mobile Home				2008
New	Approved Basic 06-100780BP	Two-story SFR with attached garage -2003 IRC		Plan: 2023 Pin P	2008
New	approved basic 07-107605 BP	2003 IRC	Plan# 2225 H	2-story sfr w/attached g	2008
New	SENT PERMIT FOLDER TO RECORDS ROOM 12/01/08 DM APPROVED basic 07-107737 BP				2008
New	Approved Basic 06-102296 BP	2003 IRC	Plan: 2717	Two-story SFR with attached garage	2008
New	Approved basic 07-107605 BP	2003 IRC	Plan# 2225 H	2-story sfr w/attached g	2008
New	Approved Basic 06-102296 BP	2003 IRC	Builders Plan: 2717 T		2008
New	Two story SFR with attached Garage				2008
New	Two Story SFR w/attached garage	2003 IRC	Plan: 1507		2008



Accessory Dwelling Units

Index # - File Name: 1.0022 - Single Family Dwellings Data\_Snohomish County.pdf

New	Approved Basic 07-114185-BP	Plan No: 2S-1823	2006 IRC	Split Level two story w/	2008
New	Approved Basic 07-114185-BP	Plan No: 2S-1823	2006 IRC	Split Level two story w/	2008
New	Approved Basic # 07-108154 BP	2006 IRC Plan # 06.12.113		Two story SFR with attached Gara	2008
New	Approved Basic 08-100057BP	2006 IRC Plan: 1600H		2-story sfr w/ attached garage	2008
New	Approved Basic 07-114185-BP	Plan No: 2S-1823	2006 IRC	Split Level two story w	2008
New	Approved Basic 08-110042-BP	Plan 1660 B	2006 IRC	Rambler w/ attached gar	2008
New	Approved Basic 07-110214-BP	2006 IRC Plan # 1117 A		2-Story SFR w/ attached g	2008
New	Approved Basic 07-110363-BP	Plan No. 1027 A	2006 IBC/IRC	2 story cottage -no garage	2008
New	2 story SFR w/ attached garage				2008
New	Approved Basic 08-100005-BP	Plan No 1329 A	2006 IRC	2 story Cottage - no garage	2008
New	Approved Basic 07-109127-BP	2006 IRC Plan # 1717 A		2-Story SFR w/ attached ga	2008
New	Approved Basic 07-110565-BP	Builder No. 1428B	2006 IRC	2 story SFR	2008
New	Approved Basic 07-110121-BP	2006 IRC Plan # 1418 A		2-Story SFR w/ attached g	2008
New	Approved Basic 08-100931-BP	Plan No 1618 B	2006 IRC	2 story SFR w/ attached gar	2008
New	Approved Basic 07-109361-BP	Builder No. 1318 C	2006 IRC/WSEC	2 story SFR w/	2008
New	Approved Basic 08-102872-BP	Plan No. 2059	2006 IRC	2 story SFR w/ attached garage	2008
New	Approved Basic 07-112324-BP	Plan No 2011 C	2006 IRC	2 story SFR w/ attached 2 or 3 car o	2008
New	Approved BP 07-113578-BP	Plan No 2411 A	2006 IRC	2 story SFR w/ 2 or 3 car option	2008
New	Approved Basic 08-100954-BP	Plan No. 2421 C	2006 IRC	2 story SFR w/ attached gara	2008
New	Approved Basic 08-100938-BP	Plan No 2075 C	2006 IRC	2 story SFR w/ attached gara	2008
New	Approved Basic 08-100767-BP	Plan No. 1821 C	2006 IRC	2 story SFR w/ two or three car o	2008
New	Approved Basic 08-100965-BP	Plan No 2031 A	2006 IRC	2 story SFR w/ attached garage	2008
New	Approved Basic 07-112324-BP	Plan No 2011 C	2006 IRC	2 story SFR w/ attached 2 or 3 car o	2008
New	Approved Basic 07-112525-BP	2006 IRC Plan # 2265 C		2-Story SFR w/attached g	2008
New	Approved Basic 08-100766-BP	Plan No 2565 B	2006 IRC	2 story SFR w/ attached 2 or 3 ca	2008
New	Approved basic 07-107576 BP	2006 IRC Plan# 2255 C		2-story sfr w/attached ga	2008
New	SENT PERMIT FOLDER TO RECORDS ROOM 11/04/08 DM Approved Basic 08-100767-BP Plan				2008
New	Approved Basic 07-114388-BP	Plan No. 2723 C	2006 IRC	2 story w/ attached 2 or 3 car o	2008
New	Permit to get final from expired permit # 06-102457 RK Two story SFR with attached Garage				2008
New	SENT PERMIT FOLDER TO RECORDS ROOM 10/23/08 DM Two story SFR with attached Garage (				2008
New	58 ft x 66 ft two story SFR with attached garage				2008
New	SENT PERMIT FOLDER TO RECORDS ROOM 10/23/08 DM Two story SFR with attached Garage				2008
New	Rambler with attached garage				2008
New	2 story SFR w/ attached garage				2008
New	This permit to renew expired permit 06-127950 RK. (No changes made)				2008
New	2296 sq ft Rambler with attached Garage				2008
New	2 story SFR w/ third story unfinished attic space and w/ attached garage				2008
New	SENT PERMIT FOLDER TO RECORDS ROOM 12/01/08 DM Two-story residence with attached ga				2008
New	Rambler with unfinished basement and attached 3 car garage				2008
New	SFR rambler with attached garage (main residence) and an attached accessory apartment with c				2008
New	2-story SFR w/open deck				2008
New	Two story SFR with finished Basement & attached Garage				2008
New	2008 27 x 45 4 Golden West Savannah				2008
New	EXPIRED WITHOUT COUNTY APPROVAL TO USE OR OCCUPY 11/12/09 DM 2 story Log cabin SFR				2008
New	2-story SFR w/garage and covered deck				2008
New	2 story sfr w/ attached garage				2008
New	SENT PERMIT FOLDER TO RECORDS ROOM 10/15/08 DM Daylight rambler w/attached garage				2008

Accessory Dwelling Units

Index # - File Name: 1.0022 - Single Family Dwellings Data\_Snohomish County.pdf

New	SENT PERMIT FOLDER TO RECORDS ROOM 10/22/08 DM	2 story w/ semi finished basement & ;	2008
New	*Issued under tax roll # 004733-000-016-24*	2-story SFR over finished daylight basement w/at	2008
New	New SFR	w/attached garage	2008
New	Install new 64 ft x 27 ft MH (2008 Homebuilders NW Inc)		2008
New	SENT PERMIT FOLDER TO RECORDS ROOM 10/27/08 DM	Approved basic 06-133784 BP 2003	2008
New	Rambler style single family residence w/ garage		2008
New	2-story sfr w/attached garage		2008
New	Approved Basic 05-118736BP 2003 IRC	2 story SFR w/attached garage Plan:2999w/	2008
New	2 story SFR		2008
New	Renewal of Permit 06-126726-RK - All conditions of permit 06-126726-RK shall apply to this ren		2008
New	Approved Basic 07-1052036-BP 2006 IRC	Plan # 3056C 2-Story SFR w/ attached	2008
New	Pending Basic 08-107222 BP 2006 IRC	Plan: 3061 A Two story SFR with attached Garag	2008
New	Approved Basic 08-103831 BP Plan No. 4044 B	2006 IBC Two	2008
New	1 story SFR w/ attached garage		2008
New	2-Story SFR		2008
New	To get final on expired permit 05-126442 RK	Two story SFR with attached Garage	2008
New	two story SFR w/ daylight basement and attached garage		2008
New	Rambler w/ atchd 4 car garage****Fire Damage Repair-This permit originally renewed to comp		2008
New	To get final on expired permit 05-128996 RK	Two story SFR with attached Garage	2008
New	SENT PERMIT FOLDER TO RECORDS ROOM 10/22/08 DM	2-Story over unfinished basement w/;	2008
New	2-story SFR w/garage		2008
New	2 story SFR w/ attached garage		2008
New	SENT PERMIT FOLDER TO RECORDS ROOM 10/15/08 DM	Rambler-style SFR over unfinished bas	2008
New	Two Story SFR w/ attached garage		2008
New	SFR on second story w/ attached garage first story		2008
New	2-story SFR w/ finished basement, attached garage and decks		2008
New	One story SFR with semi-finished Basement To get final on expired permit 04-115308 RK		2008
New	Rambler with attached garage		2008
New	2006 26 ft 8 in X 60 ft Double-wide MH		2008
New	Rambler style w/unfinished basement and garage		2008
New	Two-story residence with attached garage		2008
New	Two story SFR with finished Basement & attached Garage		2008
New	To finish work on expired permit 01-105273 RK	1249 sq ft Rambler with attached Garage	2008
New	Two-story residence with attached garage		2008
New	New 2 story SFR w/ attached garage		2008
New	Two story SFR with attached Garage		2008
New	Two story SFR with attached Garage		2008
New	2480 sq ft SFR Rambler with attached Garage		2008
New	Double Wide Moble Home		2008
New	New 2 story SFR w/attached garage		2008
New	2001 double wide MH		2008
New	Two-story SFR with attached garage		2008
New	New Manufactured Home		2008
New	Rambler style w/basement and garage		2008
New	doublewide manufactured home		2008
New	Demo existing SFR and rebuild a two story w/ finished basement and attached garage		2008
New	Rambler with garage attached		2008

Accessory Dwelling Units

Index # - File Name: 1.0022 - Single Family Dwellings Data\_Snohomish County.pdf

New	Do Not expire until after 4/15/10 per DM	New 2 story SFR w/ attached garage ( MH to be remc	2008
New	Rambler style sfr w/attached garage		2008
New	To get final on expired permit for 3112 sq ft SFR with 255 sq ft Unfinished Basement 00-106070		2008
New	Residence for entertaining with attached garage - built without a permit		2008
New	Two story SFR with attached Garage		2008
New	Fire Damage Repair to SFR		2008
New	2 story SFR (cabin) w/ covered deck		2008
New	Two-story SFR with attached garage - 2003 IRC		2008
New	SFR rambler w/ attached garage (see 08-104859 for guest house conversion)		2008
New	2526 sq ft SFR Rambler		2008
New	Two-story w/unfinished basement		2008
New	2-story SFR w/garage & covered deck		2008
New	2-story SFR w/garage		2008
New	SFR Rambler with attached garage		2008
New	2 - story SFR w/ attached garage		2008
New	SENT PERMIT FOLDER TO RECORDS ROOM 12/01/08 DM	2 story home w/ 2 bedroom plus boni	2008
New	2-story SFR w/garage		2008
New	2-story SFR w/garage		2008
New	1810 sq ft SFR with 1152 sq ft finished Basement & attached Garage		2008
New	1989 Fugua Sierra Lodge Mobile Home		2008
New	New 2 story SFR w/ attached garage - (remove existing mobile and detached garage)		2008
New	Approved Basic 07-110747 BP	2006 IRC	Plan: 50070-A3T Two-s
New	828 sq ft two story SFR with attached Garage		2008
New	Two story SFR with attached Garage		2008
New	Approved basic 07-109086 BP	2006 IRC	Plan: 1561 Two-story Duplex with attac
New	2 story SFR w/ attached garage (Construction has begun, see 08-102634 CT)		2008
New	SENT PERMIT FOLDER TO RECORDS ROOM 12/01/08 DM	1108 sq ft SFR	2008
New	Approved Basic 08-105815-BP	Plan No. 1292 FDU	2006 IRC 2 story DUPLEX w/ attached
New	Rambler with attached garage		2008
New	Two-story SFR with attached garage		2008
New	New 2 story SFR w/ attached garage		2008
New	SFR Rambler		2008
New	Single story single family residence w/ attached garage.		2008
New	2-story sfr w/attached garage		2008
New	1840 sq ft Rambler with attached Garage		2008
New	SENT PERMIT FOLDER TO RECORDS ROOM 12/01/08 DM	New two story sfr with attached gara	2008
New	SENT PERMIT FOLDER TO RECORDS ROOM 10/22/08 DM	Two Story SFR with Attatched Garage	2008
New	Building permit for detached, 2 bedroom, 805 sqft accessory apartment with attached garage/s		2008
New	New SFR rambler w/ attached garage replacing 1910 farmhouse		2008
New	Rambler Style SFR w/attached garage.		2008
New	2008 Golden West, 30 x 56 double wide, manufactured home proposed as a detached accessory		2008
New	1986 Cameron Mobile Home for Temporary Dwelling		2008
New	SENT PERMIT FOLDER TO RECORDS ROOM 10/15/08 DM	Rambler w/ 2 car attchd garage	2008
New	Rambler style w/garage		2008
New	Two story SFR w/ attached garage		2008
New	new duplex		2008
New	1 story SFR w/ attached garage		2008

Accessory Dwelling Units

Index # - File Name: 1.0022 - Single Family Dwellings Data\_Snohomish County.pdf

New	2-story SFR w/covered deck/porch	2008
New	Rambler style SFR w/attached garage.	2008
New	2 story SFR w/ finished basement	2008
New	New SFR w/ attached garage replacing existing manufactured home in same footprint	2008
New	New SFR no garage	2008
New	New two story SFR w attached garage	2008
New	Construction of a two-story SFR	2008
New	Two Story SFR w/ attached garage	2008
New	SENT PERMIT FOLDER TO RECORDS ROOM 12/01/08 DM Two-story residence	2008
New	rambler style SFR w/ attached garage	2008
New	1187 sq ft Rambler with attached Garage	2008
New	Daylight Basement Rambler with Attached Garage.	2008
New	2-story Duplex w/garage	2008
New	New 1 story SFR w/ attached garage (replacing previously demolished SFR)	2008
New	Approved basic 07-109086 BP 2006 IRC Plan: 1561 Two-story Duplex with attac	2008
New	Two story Duplex with attached garage (Previous Mobile removed)	2008
New	Duplex	2008
New	Two-story residence with attached garage	2008
New	2 story sfr w/attached garage unfinished basement See related permit 08 109952 RK	2008
New	Two-story single family residence BFE = 21.5 NGVD	2008
New	2 story w/ bonus room above attached 3 car garage	2008
New	SENT PERMIT FOLDER TO RECORDS ROOM 10/22/08 DM 1,708 sf residence with 677 sf loft and	2008
New	Permit to allow final inspection for expired permit 05-127297RK (per Dan Daly)	2008
New	2008 42 ft X 50 ft Triple-Wide MH	2008
New	Two story SFR	2008
New	26.5 ft x 70 ft 2008 Liberty	2008
New	Rambler with attached garage	2008
New	768 sq ft SFR	2008
New	2-story SFR w/garage	2008
New	Approved Basic 08-102563 BP IRC 2006 Plan: 08-02-109 2430 sq ft Duplex with attached	2008
New	Rambler with attic above attached garage	2008
New	2001 66 ft X 40 ft Pacifica Triple-wide Mobile Home	2008
New	1993 Doublewide Mobile Home	2008
New	2008 70 ft X 40 ft Fleetwood Manufactured Home	2008
New	1724 sq ft Rambler with attached Garage	2008
New	1940 sq ft Rambler with attached Garage	2008
New	Two-story residence with attached garage	2008
New	2008 Champion Silvercrest Mobile Home	2008
New	Two story SFR with unfinished Basement & attached Garage	2008
New	Demolish existing SFR and Detached garage and rebuild 2 story SFR w/ finished basement, attac	2008
New	Replacing existing MH with Split level w/ attached garage	2008
New	SENT PERMIT FOLDER TO RECORDS ROOM 12/01/08 DM New 2 story SFR w/ attached garage	2008
New	Rambler style duplex with attached garages	2008
New	SENT PERMIT FOLDER TO RECORDS ROOM 10/15/08 DM Renewed now 3/25/08 NOT RENEWEI	2008
New	Two story SFR with attached Garage	2008
New	Garage with residence on 2nd floor	2008
New	SENT PERMIT FOLDER TO RECORDS ROOM 12/01/08 DM 1341 sq ft SFR with 672 sq ft finished	2008

Accessory Dwelling Units

Index # - File Name: 1.0022 - Single Family Dwellings Data\_Snohomish County.pdf

New	New Doublewide Mobile Home	2008
New	SENT PERMIT FOLDER TO RECORDS ROOM 10/23/08 DM Two-story residence with attached ga	2008
New	SENT PERMIT FOLDER TO RECORDS ROOM 11/21/08 DM Two-story home w/ attached 2 car ga	2008
New	SENT PERMIT FOLDER TO RECORDS ROOM 11/21/08 DM Two-story home w/ attached 2 car ga	2008
New	SENT PERMIT FOLDER TO RECORDS ROOM 11/26/08 DM 2144 sq ft SFR with 806 sq ft semi-fini	2008
New	Converting upstairs of garage into living living space	2008
New	New SFR w/ attached garage	2008
New	Rambler with attached garage, replacing residence destroyed in a fire	2008
New	2 story SFR w/ attached garage and unfinished storage. 07-114863-D1, 07114786FZ	2008
New	2-Story single family residence with an attached 1-car garage.	2008
New	Two story SFR with attached Garage	2008
New	Two-story residence with garage in lower level	2008
New	Two-story residence with garage in lower level	2008
New	Duplex with attached Garage	2008
New	SENT PERMIT FOLDER TO RECORDS ROOM 12/01/08 DM 2-story sfr w/attached garage	2008
New	SFR Rambler	2008
New	SENT PERMIT FOLDER TO RECORDS ROOM 10/27/08 DM 2-story SFR w/garage	2008
New	New SFR (utilizing existing foundation to existing house to be demolished)	2008
New	Rambler with attached garage	2008
New	SENT PERMIT FOLDER TO RECORDS ROOM 12/01/08 DM one and 1/2 story sfr w/ attached gar	2008
New	20ft x 40ft 1967 Double Wide VanDyk, Guest House - Mobile Home	2008
New	SFR Rambler **STOP WORK per Ralph Walker 05/14/08 dsb**	2008
New	2-story sfr w/attached garage	2008
New	2-story w/finished basement & garage	2008
New	2 story SFR w/ attached garage	2008
New	Two story SFR with unfinished Basement & attached Garage	2008
New	Rambler style SFR w/garage and covered deck/porch	2008
New	Tri-level residence with attached garage	2008
New	1984 48 ft X 24 ft Double Wide Mobile Home	2008
New	2-story w/garage, patio and covered deck	2008
New	Proposed 2924 sq ft single family residence with 1016 sq ft attached accessory apartment.	2008
New	SENT PERMIT FOLDER TO RECORDS ROOM 10/27/08 DM 2398 sq ft with SFR with 1090 Semi Fi	2008
New	1767 sq ft Rambler with attached Garage	2008
New	2112 sq ft SFR Rambler	2008
New	2 story SFR w/ attached garage	2008
New	Rambler with Attached Garage(Mobile home removed. Abooth 2/11/09)	2008
New	New permit to complete 04-115280-RK (existing plans OK per N.O.) 2-story SFR w/garage	2008
New	2636 sq ft Rambler	2008
New	Two-story residence with attached garage	2008
New	2412 sq ft SFR with finished Basement	2008
New	Rambler Style Single Family Residence	2008
New	SENT PERMIT FOLDER TO RECORDS ROOM 10/22/08 DM 2-story sfr w/attached carport (no gar	2008
New	SENT PERMIT FOLDER TO RECORDS ROOM 11/26/08 DM 2-Story SFR	2008
New	2400 sq ft Rambler with 990 sq ft Semi-Finished Basement	2008
New	Approved Basic 08-100502 BP Plan: 1571 2006 IRC 1571 sq ft Rambler with Garage	2008
New	1450 sq ft Rambler with Attached Garage	2008
New	New Two story SFRw/ attached garage (demo existing cabin and rebuild in same location)	2008

Accessory Dwelling Units

Index # - File Name: 1.0022 - Single Family Dwellings Data\_Snohomish County.pdf

New	SFR	2008
New	Two-story residence with daylight basement and attached garage	2008
New	Two-story residence with attached garage with 2nd floor finished, liveable space	2008
New	Permit to get final from expired MH permit 215776 1987 52 ft X 28 ft Fleetwood MH	2008
New	Rambler w/ attached garage	2008
New	2008 doublewide mobile home	2008
New	EXPIRED WITHOUT COUNTY APPROVAL TO USE OR OCCUPY 3/18/10 DM Two Story SFR with At	2008
New	Permit to finish work on expired permit 05-101327 RK Two story SFR with attached Garage	2008
New	1 story SFR - no garage	2008
New	Two story SFR with finished daylight basement, loft, and attached garage	2008
New	SENT PERMIT FOLDER TO RECORDS ROOM 10/22/08 DM 2 story w/ attached 2 car garage	2008
New	Two story SFR	2008
New	Two-story SFR with attached garage	2008
New	SFR with finished Basement with attached Garage	2008
New	SENT PERMIT FOLDER TO RECORDS ROOM 10/22/08 DM Two story SFR with 350 sq ft finished l	2008
New	1150 sf single family residence with 384 sf garage	2009
New	SENT PERMIT FOLDER TO RECORDS ROOM 10/27/08 DM 1736 sq ft single family residence with	2009
New	Two-story residence with attached garage	2009
New	Two-story SFR with attached garage	2009
New	Two-story SFR with attached garage	2009
New	SENT PERMIT FOLDER TO RECORDS ROOM 10/22/08 DM Two story SFR with attached Garage	2009
New	Two-story SFR with attached garage	2009
New	Two story SFR with attached Garage	2009
New	Two story SFR	2009
New	Rambler with attached garage	2009
New	Two Story SFR with Attached Garage	2009
New	2-story w/garage	2009
New	28x60, 1997 Marlette (will be back with recorded CASP om 5-26-09 to pick up permit dm)	2009
New	Construction of a 2203 square foot single family residence with attached 418 square foot garage	2009
New	2-story sfr w/attached garage	2009
New	847 sq. ft single story SFR w/ attached garage	2009
New	2009 58 ft X 40 ft Triple-Wide Manufactured Home	2009
New	Two Story SFR with Attached Garage	2009
New	24x64 1979 Silvercrest w/10x20 pod	2009
New	SENT PERMIT FOLDER TO RECORDS ROOM 11/24/08 DM New SFR - rambler style w/ attached g	2009
New	843 sf detached accessory apartment	2009
New	Two-story residence with attached garage	2009
New	Rambler style SFR w/ attached garage	2009
New	Two-story residence with daylight basement and attached garage	2009
New	New triple wide mobile	2009
New	2008 Triple-wide Goldenstate Manufactured Home	2009
New	24x60, 1978 Homette	2009
New	SFR - 2 story home with attached 2 car garage	2009
New	Rambler style home with attached 2-car garage	2009
New	583 sq ft detached accessory apartment	2009
New	Two-story SFR with attached garage	2009
New	Two-story single-family residence with attached Garage	2009

Accessory Dwelling Units

Index # - File Name: 1.0022 - Single Family Dwellings Data\_Snohomish County.pdf

New	Rambler with attached garage	2009
New	844 sq ft detached Accessory Apartment with detached Garage	2009
New	2 story SFR	2009
New	Construction of a two-story single family residence (no attached garage). NOTE: Amounts rede	2009
New	1767 sf rambler with 484 sf attached garage	2009
New	Reversed Expire Status for a 1 time final insepction per Alan Husby 5/12/15 EXPIRED WITHOUT	2009
New	New 2 story sfr w/attached garage	2009
New	Detached Accessory Apartment	2009
New	2008 27 ft X 66 ft Magnolia Double-Wide	2009
New	Rambler with bonus room upstairs and garage	2009
New	Rambler style sfr w/attached garage	2009
New	2 story SFR with attached garage	2009
New	SFR Rambler	2009
New	Two Story SFR with Attached Garage	2009
New	Two-story residence with attached garage	2009
New	One-story residence with finished basement and attached garage, Plans revised 8-26-09 ahusby	2009
New	Rambler with 3-car garage	2009
New	SENT PERMIT FOLDER TO RECORDS ROOM 10/23/08 DM Two story SFR with finished Basement	2009
New	New split level style single family residence	2009
New	2-story SFR w/garage	2009
New	Two-story Duplex with attached garages	2009
New	Mobile home - 2010 Palm Harbor double wide	2009
New	2800 sf rambler	2009
New	2133 sf single family residence with 1209 unfinished basement and 562 sf attached garage	2009
New	Rambler style sfr w/attached garage	2009
New	Rambler recorded Affidavit 200907060262	2009
New	2629 sq ft SFR with attached 629 sq ft garage	2009
New	New home, 2 story, 2 bedrooms with office and study	2009
New	Rambler with attached Garage	2009
New	Check for removal of MH 30 days after final inspection --- dm 10-30-09 46 ft x 73 ft SFR with da	2009
New	Rambler with attached two-car garage	2009
New	Two Story SFR with Attached Carport	2009
New	Two Story SFR tith Attached Garage	2009
New	Split level single family residence to be rebuilt due to extensive fire damage.	2009
New	Tree Damage Repair to SFR	2009
New	Proposed rambler with daylight basement to be rebuilt due to fire damage. Foundation is all th	2009
New	New SFR with unfinished basement (no garage)	2009
New	Rambler style w/garage & patio	2009
New	Two-story residence	2009
New	Could not pay renewal fee - will come back 8/10/09 rar. SENT PERMIT FOLDER TO RECORDS RO	2009
New	Rambler Style Single Family Residence w/Garage & Covered Deck	2009
New	SFR w/ attached garage	2009
New	Rambler style Single Family Residence w/garage and unfinished basement	2009
New	Three Story SFR with Attached Garage	2009
New	SENT PERMIT FOLDER TO RECORDS ROOM 11/21/08 DM 32 ft x 64 ft SFR	2009
New	1573 sq ft SFR	2009
New	Two story home with basement and attached garage. ***Revised site plan received 1/8/10 - St	2009

Accessory Dwelling Units

Index # - File Name: 1.0022 - Single Family Dwellings Data\_Snohomish County.pdf

New	SENT PERMIT FOLDER TO RECORDS ROOM 11/18/08 DM	Two story SFR with attached Garage	2009
New		Two story SFR for Director s residence	2009
New		841 sf garage with 2nd floor activity room	2009
New		single story SFR w/ attached garage	2009
New		1767 sq ft Rambler	2009
New		Two Story Duplex with Attached Garages	2009
New		new permit to final expired permit 07-105094	2009
New		Rambler	2009
New		Mobile home 14 x 66, 1985 Skyline	2009
New		1359 Sq Ft Rambler, Lateral design by H.N. Lehtinen, P.E. 24628	2009
New		Rambler style sfr w/attached garage	2009
New	Approved basic 07-109086 BP	2006 IRC Plan: 1561 Two-story Duplex with attac	2009
New		2 story SFR w/ semi-finished basement and attached garage	2009
New		Two-story SFR with attached garage	2009
New		Mobile home has been removed from property 1/15/2010 Two-story SFR with attached garage	2009
New		Detached Accessory Apartment . Garage and storage on main floor with 838 sqft of living space	2009
New		Proposed 1 story SFR w/ unfinished basement w/ attached gara	2009
New		Install new water service line to Single Family Residence	2009
New	SENT PERMIT FOLDER TO RECORDS ROOM 11/24/08 DM	Duplex	2009
New		Building Permit for detached Accessory Apartment - garage with accessory apartment on 2nd fl	2009
New		New farm house (old SFR to be demolished)	2009
New		Rambler style sfr w/attached garage	2009
New		To FINAL Expired 06-131110 RK for a: Two-story residence with attached garage	2009
New		New single family residence, 2-story home with attached 5-car garage and wine cellar (using exi	2009
New		Proposed rambler single family residence.	2009
New		1922 sq ft Rambler with attached Garage gate code 1492	2009
New		2-story Single family residence w/ covered decks	2009
New		New SFR, Two story style with attached two car garage	2009
New		Correction notice issued. Due to the discrepancy of the location of the structures and the actua	2009
New		2-story w/garage	2009
New		1987 27 ft X 56 ft Double-wide Barrington Fleetwood MH	2009
New		Manufactured home, 2009 Skyline 40 x 60	2009
New		New permit for final inspection for expired permit 06-132690-RK 1820 sq ft single family reside	2009
New	Approved Basic 08-103833 BP	Plan No. 4044 C 2006 IBC	Two 2009
New	SENT PERMIT FOLDER TO RECORDS ROOM 11/24/08 DM	Approved Basic 07-1052036-BP	2 2009
New	SENT PERMIT FOLDER TO RECORDS ROOM 10/28/08 DM	Approved Basic 06-103358BP	20 2009
New		2 story sfr w/attached garage	2009
New	SENT PERMIT FOLDER TO RECORDS ROOM 10/28/08 DM	Approved Basic 06-103360BP	2003 I 2009
New	SENT PERMIT FOLDER TO RECORDS ROOM 10/28/08 DM	Approved basic 05-121435 BP	200 2009
New		Work to continue expired permit to obtain final inspection. Approved Basic 04-121596BP	2 Str 2009
New		2- story sfr w/attached garage	2009
New		2 story sfr w/attached garage	2009
New	Approved Basic 06-103358BP	2003 IRC 2 story SFR w/attached garage	Plan:3840A 2009
New		2 story sfr w/attached garage	2009
New	Approved Basic 08-103521 BP	Plan No. 4044 A 2006 IBC	Two 2009
New	Approved basic 09-104862 BP	2006 IRC Plan# 1930-02AD	2-story sfr w/attached ga 2009
New	Approved Basic 08-109064-BP	Plan No. 3822-A 2006 IRC	2 story SFR w/ attached garage 2009



Accessory Dwelling Units

Index # - File Name: 1.0022 - Single Family Dwellings Data\_Snohomish County.pdf

New	Approved Basic 08-109063-BP	Plan No. 3821-B	2006 IRC	2 story SFR w/ attached garage	2009
New	Approved Basic 08-109068-BP	Plan No. 3824-A	2006 IRC	2 story SFR w/ attached garage	2009
New	Approved Basic 08-109066-BP	Plan No. 3823-A	2006 IRC	2nd story SFR w/ attached garage	2009
New	Approved Basic 08-109064-BP	Plan No. 3822-A	2006 IRC	2 story SFR w/ attached garage	2009
New	Approved basic 09-102932 BP	2006 IRC	Plan# 3806 A/B	2-story sfr w/attached garage	2009
New	Approved Basic 08-109063-BP	Plan No. 3821-B	2006 IRC	2 story SFR w/ attached garage	2009
New	Approved Basic 08-111193-BP	Plan No. 3803-A	2006 IRC	2 story SFR w/ attached garage	2009
New	Approved Basic 08-111195-BP	Plan No. 3804-AB	2006 IRC	2 story SFR w/ attached garage	2009
New	Approved Basic 08-111196-BP	Plan No. 3805-AB	2006 IRC	2 story SFR w/ attached garage	2009
New	Approved Basic 08-111195-BP	Plan No. 3804-AB	2006 IRC	2 story SFR w/ attached garage	2009
New	Approved Basic 08-109069-BP	Plan No. 3824-B	2006 IRC	2 story SFR w/ attached garage	2009
New	Approved Basic 08-109065-BP	Plan No. 3822-B	2006 IRC	2 story SFR w/ attached garage	2009
New	Approved Basic 08-109066-BP	Plan No. 3823-A	2006 IRC	2nd story SFR w/ attached garage	2009
New	Approved Basic 08-109068-BP	Plan No. 3824-A	2006 IRC	2 story SFR w/ attached garage	2009
New	Approved Basic 08-109065-BP	Plan No. 3822-B	2006 IRC	2 story SFR w/ attached garage	2009
New	Approved Basic 08-109067-BP	Plan No. 3823-B	2006 IRC	2 story SFR w/ attached garage	2009
New	Approved Basic 08-109069-BP	Plan No. 3824-B	2006 IRC	2 story SFR w/ attached garage	2009
New	Approved Basic 08-109062-BP	Plan No 3821-A	2006 IRC	2 story SFR w/ attached garage	2009
New	New SFR w/ attached garage				2009
New	New SFR w/attached garage				2009
New	New 2 story SFR w/ attached garage				2009
New	2-story SFR w/ garage and covered deck				2009
New	Rambler with daylight garage/basement and loft				2009
New	Converting 836 sq ft of existing Ag building to Accessory Apartment				2009
New	268 Covered Porch in place of patio				2009
New	SENT PERMIT FOLDER TO RECORDS ROOM 12/01/08 DM 2 story SFR w/ attached garage				2009
New	SENT PERMIT FOLDER TO RECORDS ROOM 10/23/08 DM Two story SFR with attached Garage				2009
New	Approved basic 09-104027 BP	2006 IRC	Plan# 3820 B	2-story sfr w/attached garage	2009
New	Approved basic 09-104026 BP	2006 IRC	Plan# 3820 A	2-story sfr w/attached garage	2009
New	Approved Basic 08-111193-BP	Plan No. 3803-A	2006 IRC	2 story SFR w/ attached garage	2009
New	Approved Basic 08-111195-BP	Plan No. 3804-AB	2006 IRC	2 story SFR w/ attached garage	2009
New	Approved basic 09-104025 BP	2006 IRC	Plan# 3801/3801 opt bath B	2-story sfr w/attached garage	2009
New	Approved Basic 08-111196-BP	Plan No. 3805-AB	2006 IRC	2 story SFR w/ attached garage	2009
New	Approved basic 09-104026 BP	2006 IRC	Plan# 3820 A	2-story sfr w/attached garage	2009
New	Approved basic 09-102932 BP	2006 IRC	Plan# 3806 A/B	2-story sfr w/attached garage	2009
New	Approved Basic 08-111195-BP	Plan No. 3804-AB	2006 IRC	2 story SFR w/ attached garage	2009
New	Approved Basic 08-111196-BP	Plan No. 3805-AB	2006 IRC	2 story SFR w/ attached garage	2009
New	Approved Basic 08-111194-BP	Plan No. 3803-B	2006 IRC	2 story SFR w/ attached garage	2009
New	Approved Basic 07-110568-BP	Builder No. 1511A	2006 IRC / WSEC	2 story SFR w/ attached garage	2009
New	Approved BP 07-110124-BP	Plan No. 1017 A	2006 IBC/IRC	2 stroy SFR w/ attached 1 car garage	2009
New	Approved Basic 08-111196-BP	Plan No. 3805-AB	2006 IRC	2 story SFR w/ attached garage	2009
New	Approved Basic 08-111191-BP	Plan No.3801-B	2006 IRC	2 story SFR w/ attached garage	2009
New	Approved Basic 08-111194-BP	Plan No. 3803-B	2006 IRC	2 story SFR w/ attached garage	2009
New	Approved Basic 08-111195-BP	Plan No. 3804-AB	2006 IRC	2 story SFR w/ attached garage	2009
New	Approved Basic 08-111194-BP	Plan No. 3803-B	2006 IRC	2 story SFR w/ attached garage	2009
New	Approved Basic 08-111195-BP	Plan No. 3804-AB	2006 IRC	2 story SFR w/ attached garage	2009
New	Approved Basic 08-111193-BP	Plan No. 3803-A	2006 IRC	2 story SFR w/ attached garage	2009

Accessory Dwelling Units

Index # - File Name: 1.0022 - Single Family Dwellings Data\_Snohomish County.pdf

New	Approved Basic 08-111196-BP	Plan No. 3805-AB	2006 IRC	2 story SFR w/ attached ga	2009
New	Approved Basic 08-111195-BP	Plan No. 3804-AB	2006 IRC	2 story SFR w/ attached g	2009
New	Approved Basic 08-111190-BP	Plan No. 3801-A	2006 IRC	2 story SFR w/ attached gara	2009
New	Approved Basic 08-111194-BP	Plan No. 3803-B	2006 IRC	2 story SFR w/ attached g	2009
New	Approved Basic 08-111196-BP	Plan No. 3805-AB	2006 IRC	2 story SFR w/ attached ga	2009
New	Approved Basic 08-111191-BP	Plan No.3801-B	2006 IRC	2 story SFR w/ attached garage	2009
New	Approved Basic 08-111193-BP	Plan No. 3803-A	2006 IRC	2 story SFR w/ attached ga	2009
New	Approved Basic 08-111195-BP	Plan No. 3804-AB	2006 IRC	2 story SFR w/ attached g	2009
New	Approved Basic 08-111190-BP	Plan No. 3801-A	2006 IRC	2 story SFR w/ attached gara	2009
New	Approved Basic 08-111193-BP	Plan No. 3803-A	2006 IRC	2 story SFR w/ attached ga	2009
New	Approved Basic 08-111195-BP	Plan No. 3804-AB	2006 IRC	2 story SFR w/ attached g	2009
New	Approved Basic 08-111195-BP	Plan No. 3804-AB	2006 IRC	2 story SFR w/ attached g	2009
New	Approved basic 09-104025 BP	2006 IRC	Plan# 3801/3801 opt bath B	2-story sfr w/a	2009
New	Approved Basic 08-111194-BP	Plan No. 3803-B	2006 IRC	2 story SFR w/ attached g	2009
New	Rambler with attached garage				2009
New	850 sf Accessory Apartment above detached garage				2009
New	Approved basic 07-109645 BP	2006 IRC	Plan# 2278	2-story sfr w/attached garage	2009
New	3370 sf rambler with attached garage - 2006 IRC				2009
New	2009 Laurelwood double wide as an Accessory Apartment				2009
New	Two-story residence				2009
New	28 ft x 57 ft SFR with attached garage	Application extended 180 days to May 13, 2009 per M. V			2009
New	Approved Basic 07-110568-BP	Builder No. 1511A	2006 IRC / WSEC	2 story SFR w/ att	2009
New	Approved Basic 08-101523-BP	Plan No. 2611 C	2006 IRC	2 story SFR w/ attached garage	2009
New	Approved Basic 08-111105-BP	Plan No. 1901 A	2006 IRC	2 story SFR w/attached ga	2009
New	Approved Basic 07-110119-BP	2006 IRC	Plan # 2421 A	2-Story SFR w/ attached g	2009
New	Approved Basic 08-100953-BP	Plan No 2421 B	2006 IRC	2 story SFR w/ attached ga	2009
New	Approved basic 09-104105 BP	2006 IRC	Plan# 2217A	2-story sfr w/attached gar	2009
New	Approved basic 09-105563 BP	2006 IRC	Plan# 1892	2-story sfr w/attached garag	2009
New	Approved basic 09-105563 BP	2006 IRC	Plan# 1892	2-story sfr w/attached gara	2009
New	Approved basic 09-105563 BP	2006 IRC	Plan# 1892	2-story sfr w/attached gara	2009
New	Approved basic 09-104259 BP	2006 IRC	Plan# 1273	2-story sfr w/attached garage	2009
New	Approved basic 09-104831 BP	2006 IRC	Plan# 1777	2-story sfr w/attached garage	2009
New	Approved basic 09-104259 BP	2006 IRC	Plan# 1273	2-story sfr w/attached garage	2009
New	Approved basic 09-104831 BP	2006 IRC	Plan# 1777	2-story sfr w/attached garage	2009
New	Approved basic 09-104259 BP	2006 IRC	Plan# 1273	2-story sfr w/attached garage	2009
New	Approved basic 09-104831 BP	2006 IRC	Plan# 1777	2-story sfr w/attached garage	2009
New	Approved basic 09-104831 BP	2006 IRC	Plan# 1777	2-story sfr w/attached garage	2009
New	Approved basic 09-104260 BP	2006 IRC	Plan# 1618	2-story sfr w/attached gar	2009
New	Approved basic 09-104259 BP	2006 IRC	Plan# 1273	2-story sfr w/attached garage	2009
New	Approved basic 09-104260 BP	2006 IRC	Plan# 1618	2-story sfr w/attached gar	2009
New	Approved 09-105564 BP	2006 IRC	Plan# 1432 duplex	2-story duplex w/attache	2009
New	Approved 09-105564 BP	2006 IRC	Plan# 1432 duplex	2-story duplex w/attache	2009
New	Approved basic 09-104831 BP	2006 IRC	Plan# 1777	2-story sfr w/attached garage	2009
New	Approved basic 09-104260 BP	2006 IRC	Plan# 1618	2-story sfr w/attached gar	2009
New	Approved basic 09-104259 BP	2006 IRC	Plan# 1273	2-story sfr w/attached garage	2009
New	Approved basic 09-104831 BP	2006 IRC	Plan# 1777	2-story sfr w/attached garage	2009

Accessory Dwelling Units

Index # - File Name: 1.0022 - Single Family Dwellings Data\_Snohomish County.pdf

New	Approved basic 09-104259 BP	2006 IRC	Plan# 1273	2-story sfr w/attached garage	2009
New	Approved basic 09-104831 BP	2006 IRC	Plan# 1777	2-story sfr w/attached garage	2009
New	Approved basic 09-104259 BP	2006 IRC	Plan# 1273	2-story sfr w/attached garage	2009
New	Approved basic 09-104259 BP	2006 IRC	Plan# 1273	2-story sfr w/attached garage	2009
New	Approved basic 09-104260 BP	2006 IRC	Plan# 1618	2-story sfr w/attached gar	2009
New	Approved basic 09-104831 BP	2006 IRC	Plan# 1777	2-story sfr w/attached garage	2009
New	Approved basic 09-104260 BP	2006 IRC	Plan# 1618	2-story sfr w/attached gar	2009
New	Approved basic 09-104259 BP	2006 IRC	Plan# 1273	2-story sfr w/attached garage	2009
New	Approved basic 09-104259 BP	2006 IRC	Plan# 1273	2-story sfr w/attached garage	2009
New	Approved basic 09-104831 BP	2006 IRC	Plan# 1777	2-story sfr w/attached garage	2009
New	Approved basic 09-104259 BP	2006 IRC	Plan# 1273	2-story sfr w/attached garage	2009
New	Approved basic 09-104831 BP	2006 IRC	Plan# 1777	2-story sfr w/attached garage	2009
New	Approved basic 09-104259 BP	2006 IRC	Plan# 1273	2-story sfr w/attached garage	2009
New	Approved basic 09-104831 BP	2006 IRC	Plan# 1777	2-story sfr w/attached garage	2009
New	Approved basic 09-104259 BP	2006 IRC	Plan# 1273	2-story sfr w/attached garage	2009
New	Approved basic 09-105563 BP	2006 IRC	Plan# 1892	2-story sfr w/attached gara	2009
New	Approved basic 09-104259 BP	2006 IRC	Plan# 1273	2-story sfr w/attached garage	2009
New	Approved basic 09-104260 BP	2006 IRC	Plan# 1618	2-story sfr w/attached gar	2009
New	Approved basic 09-104260 BP	2006 IRC	Plan# 1618	2-story sfr w/attached gar	2009
New	Approved basic 09-104259 BP	2006 IRC	Plan# 1273	2-story sfr w/attached garage	2009
New	Approved basic 09-104831 BP	2006 IRC	Plan# 1777	2-story sfr w/attached garage	2009
New	Approved basic 09-104259 BP	2006 IRC	Plan# 1273	2-story sfr w/attached garage	2009
New	Approved basic 09-104831 BP	2006 IRC	Plan# 1777	2-story sfr w/attached garage	2009
New	Approved basic 09-104259 BP	2006 IRC	Plan# 1273	2-story sfr w/attached garage	2009
New	Approved basic 09-104259 BP	2006 IRC	Plan# 1273	2-story sfr w/attached garage	2009
New	Approved basic 09-104259 BP	2006 IRC	Plan# 1273	2-story sfr w/attached garage	2009
New	Approved basic 09-104260 BP	2006 IRC	Plan# 1618	2-story sfr w/attached gar	2009
New	Approved Basic 08-106327-BP	Plan No. 494-2B,C	2006 IRC	2 story SFR w/ attached	2009
New	Permit to final and compleete	07-101638-RK	Two-story SFR with attached garage -	2003 IRC	2009
New	Rambler with attached 3-car garage, plus covered deck				2009
New	Approved basic 07-109644 BP	2006 IRC	Plan# 2968	2-story sfr w/attached garage w/ bon	2009
New	Approved Basic 08-100011-BP	Plan No. 1721 A	2006 IRC	2 story SFR w/ attached 2 or 3 c	2009
New	Approved Basic 07-109652-BP	Builder No. 2343 A	2006 IRC / WSEC	2 story SFR with a	2009
New	Approved Basic 07-109130-BP	2006 IRC	Plan # 2011 A	2-Story SFR w/ attached g	2009
New	Approved basic 09-101995 BP	2006 IRC	Plan# 1824 B	2-story sfr w/attached garage	2009
New	Approved Basic 08-100939-BP	Plan No 2111 A	2006 IRC	2 story SFR w/ attached gara	2009
New	Approved Basic 08-101523-BP	Plan No. 2611 C	2006 IRC	2 story SFR w/ attached garage	2009
New	Approved basic 09-102572 BP	2006 IRC	Plan# 1814 A	2-story sfr w/attached gara	2009
New	Approved Basic 08-100937-BP	Plan No 2075 B	2006 IRC	2 story SFR w/ attached gara	2009
New	Approved basic 09-102572 BP	2006 IRC	Plan# 1814 A	2-story sfr w/attached gara	2009
New	Approved Basic 08-100938-BP	Plan No 2075 C	2006 IRC	2 story SFR w/ attached gara	2009
New	Approved Basic 07-110568-BP	Builder No. 1511A	2006 IRC / WSEC	2 story SFR w/ att	2009
New	Approved Basic 07-110568-BP	Builder No. 1511A	2006 IRC / WSEC	2 story SFR w/ att	2009
New	Approved basic 09-103608 BP	2006 IRC	Plan# 1529	2-story sfr w/attached gara	2009
New	Approved basic 09-103607 BP	2006 IRC	Plan # 1239	2-story sfr w/attached garage F	2009
New	Approved basic 09-103607 BP	2006 IRC	Plan # 1239	2-story sfr w/attached garage F	2009
New	Rambler style sfr w/attached garage				2009
New	Approved basic 09-103607 BP	2006 IRC	Plan # 1239	2-story sfr w/attached garage F	2009

Accessory Dwelling Units

Index # - File Name: 1.0022 - Single Family Dwellings Data\_Snohomish County.pdf

New	Approved basic 09-103607 BP	2006 IRC	Plan # 1239	2-story sfr w/attached garage	F	2009
New	Approved basic 09-103608 BP	2006 IRC	Plan# 1529	2-story sfr w/attached garage		2009
New	Approved basic 09-104744 BP	2006 IRC	Plan# 1239 B	2-story sfr w/attached garage		2009
New	Approved basic 09-104744 BP	2006 IRC	Plan# 1239 B	2-story sfr w/attached garage		2009
New	Approved basic 09-104744 BP	2006 IRC	Plan# 1239 B	2-story sfr w/attached garage		2009
New	Approved basic 09-104744 BP	2006 IRC	Plan# 1239 B	2-story sfr w/attached garage		2009
New	Approved basic 09-104744 BP	2006 IRC	Plan# 1239 B	2-story sfr w/attached garage		2009
New	Approved basic 09-104744 BP	2006 IRC	Plan# 1239 B	2-story sfr w/attached garage		2009
New	Approved basic 09-103606 BP	2006 IRC	Plan# 1023	2-story sfr w/attached garage		2009
New	Approved basic 09-105078 BP	2006 IRC	Plan# 1233	2-story sfr w/attached garage		2009
New	Two-story residence with attached garage Permit transfered to Encore Homes Inc. 09-28-09 jrli					2009
New	Approved basic 09-105078 BP	2006 IRC	Plan# 1233	2-story sfr w/attached garage		2009
New	Approved basic 09-103606 BP	2006 IRC	Plan# 1023	2-story sfr w/attached garage		2009
New	Approved basic 09-105078 BP	2006 IRC	Plan# 1233	2-story sfr w/attached garage		2009
New	Approved basic 09-105078 BP	2006 IRC	Plan# 1233	2-story sfr w/attached garage		2009
New	Approved basic 09-103606 BP	2006 IRC	Plan# 1023	2-story sfr w/attached garage		2009
New	Approved basic 09-103606 BP	2006 IRC	Plan# 1023	2-story sfr w/attached garage		2009
New	Approved basic 09-103606 BP	2006 IRC	Plan# 1023	2-story sfr w/attached garage		2009
New	Approved basic 09-103608 BP	2006 IRC	Plan# 1529	2-story sfr w/attached garage		2009
New	Approved basic 09-105078 BP	2006 IRC	Plan# 1233	2-story sfr w/attached garage		2009
New	Approved basic 09-103607 BP	2006 IRC	Plan # 1239	2-story sfr w/attached garage	F	2009
New	Approved basic 09-103608 BP	2006 IRC	Plan# 1529	2-story sfr w/attached garage		2009
New	Approved basic 09-103608 BP	2006 IRC	Plan# 1529	2-story sfr w/attached garage		2009
New	Approved basic 09-103608 BP	2006 IRC	Plan# 1529	2-story sfr w/attached garage		2009
New	Approved basic 09-103608 BP	2006 IRC	Plan# 1529	2-story sfr w/attached garage		2009
New	Approved basic 09-103608 BP	2006 IRC	Plan# 1529	2-story sfr w/attached garage		2009
New	Approved basic 09-103608 BP	2006 IRC	Plan# 1529	2-story sfr w/attached garage		2009
New	Approved basic 09-105078 BP	2006 IRC	Plan# 1233	2-story sfr w/attached garage		2009
New	Approved Basic 07-112328-BP	Plan No. 1731 A	2006 IRC	2 story SFR w/attached 2 or 3 car		2009
New	Approved Basic 07-110568-BP	Builder No. 1511A	2006 IRC / WSEC	2 story SFR w/ att		2009
New	Approved basic 09-102572 BP	2006 IRC	Plan# 1814 A	2-story sfr w/attached garage		2009
New	Approved basic 09-102572 BP	2006 IRC	Plan# 1814 A	2-story sfr w/attached garage		2009
New	Approved Basic 07-110568-BP	Builder No. 1511A	2006 IRC / WSEC	2 story SFR w/ att		2009
New	Approved Basic 07-113146 BP	Plan No. 435-2A,B,C	2006 IRC /IBC			2009
New	Approved Basic 07-113443- BP	Plan 437-2A,B,C	2006 IRC/IBC	2 story SFR w/attached garage		2009
New	Approved Basic 07-113565 BP	Plan No. 439-2A,B	2006 IRC			2009
New	Approved basic 09-101158 BP	2006 IRC	Plan#446	2-story sfr w/attached garage		2009
New	2-story w/garage & covered porch					2009
New	Rambler style w/garage and covered deck					2009
New	Approved Basic 08-109066-BP	Plan No. 3823-A	2006 IRC	2nd story SFR w/ attached garage		2009
New	Approved Basic 08-109068-BP	Plan No. 3824-A	2006 IRC	2 story SFR w/ attached garage		2009
New	Approved Basic 08-109063-BP	Plan No. 3821-B	2006 IRC	2 story SFR w/ attached garage		2009
New	Approved Basic 08-109067-BP	Plan No. 3823-B	2006 IRC	2 story SFR w/ attached garage		2009
New	Approved Basic 08-111193-BP	Plan No. 3803-A	2006 IRC	2 story SFR w/ attached garage		2009
New	Approved Basic 08-111195-BP	Plan No. 3804-AB	2006 IRC	2 story SFR w/ attached garage		2009
New	Approved Basic 08-111196-BP	Plan No. 3805-AB	2006 IRC	2 story SFR w/ attached garage		2009
New	Approved Basic 08-111194-BP	Plan No. 3803-B	2006 IRC	2 story SFR w/ attached garage		2009

Accessory Dwelling Units

Index # - File Name: 1.0022 - Single Family Dwellings Data\_Snohomish County.pdf

New	Approved Basic 08-111190-BP	Plan No. 3801-A	2006 IRC	2 story SFR w/ attached gara	2009
New	Approved Basic 08-111195-BP	Plan No. 3804-AB	2006 IRC	2 story SFR w/ attached g	2009
New	Approved Basic 08-111193-BP	Plan No. 3803-A	2006 IRC	2 story SFR w/ attached ga	2009
New	Approved Basic 08-111196-BP	Plan No. 3805-AB	2006 IRC	2 story SFR w/ attached ga	2009
New	Approved Basic 08-111195-BP	Plan No. 3804-AB	2006 IRC	2 story SFR w/ attached g	2009
New	Approved Basic 08-111194-BP	Plan No. 3803-B	2006 IRC	2 story SFR w/ attached g	2009
New	Approved Basic 08-109069-BP	Plan No. 3824-B	2006 IRC	2 story SFR w/ attached garage	2009
New	Approved Basic 08-109063-BP	Plan No. 3821-B	2006 IRC	2 story SFR w/ attached garage	2009
New	Approved Basic 08-109067-BP	Plan No. 3823-B	2006 IRC	2 story SFR w/ attached garage	2009
New	Approved Basic 08-109064-BP	Plan No. 3822-A	2006 IRC	2 story SFR w/ attached garage	2009
New	Approved basic 09-102560 BP	2006 IRC	Plan# 1756	2-story sfr w/attached gara	2009
New	Approved basic 09-102560 BP	2006 IRC	Plan# 1756	2-story sfr w/attached gara	2009
New	approved basic 09-102560 BP	2006 IRC	Plan# 1756	2-story sfr w/attached gara	2009
New	2- story sfr w/attached garage,Engineered by Wendell Reed, P.E. 30771				2009
New	Approved Basic 08-109065-BP	Plan No. 3822-B	2006 IRC	2 story SFR w/ attached garage	2009
New	Approved Basic 08-102875-BP	Plan No 1748	2006 IRC	2 story SFR w/ attached garage	2009
New	2 story sfr w/attached garage, Lateral deisgn by Wendell Reed, P.E. 30771				2009
New	Approved basic 09-102560 BP	2006 IRC	Plan# 1756	2-story sfr w/attached gara	2009
New	Approved basic 07-111958 BP	2006 IRC	Plan# 2338	2-story sfr w/attached garage	2009
New	Approved Basic 08-101448-BP	Plan No. 1646	2006 IRC	2 story SFR w/ attached garage	2009
New	Approved basic 07-111957 BP	2006 IRC	Plan# 226-1001	2-story sfr w/attache	2009
New	Approved basic 07-111956 BP	2006 IRC	Plan# 226-1007	2-story sfr w/attached g	2009
New	Approved basic 07-111958 BP	2006 IRC	Plan# 2338	2-story sfr w/attached garage	2009
New	Approved basic 07-111963 BP	2006 IRC	Plan# 2590	2-story sfr w/attached garage	2009
New	Approved Basic 08-101448-BP	Plan No. 1646	2006 IRC	2 story SFR w/ attached garage	2009
New	Two-story residence with garage and living space in lower level				2009
New	permit to obtain final inspection for expired permit 07-101874-RK & 06-136995-D-1				2009
New	SFR Rambler with attached garage				2009
New	Approved basic 07-111956 BP	2006 IRC	Plan# 226-1007	2-story sfr w/attached g	2009
New	Approved basic 07-111957 BP	2006 IRC	Plan# 226-1001	2-story sfr w/attache	2009
New	Approved basic 07-111958 BP	2006 IRC	Plan# 2338	2-story sfr w/attached garage	2009
New	2-story sfr w/attached garage				2009
New	Approved Basic 05- 123059BP	2003 IRC	Plan: 2160	Two-story SFR with attached gara	2009
New	Approved basic 09-104155 BP	2006 IRC	Plan# 1284/1903	2-story sfr w/attached	2009
New	Approved basic 09-103979 BP	2006 IRC	Plan# 2160	2-story sfr w/attached gara	2009
New	Approved basic 09-104154 BP	2006 IRC	Plan# 1271/1856	2-story sfr w/attached ga	2009
New	Approved basic 09-103979 BP	2006 IRC	Plan# 2160	2-story sfr w/attached garage	2009
New	Approved basic 09-103979 BP	2006 IRC	Plan# 2160	2-story sfr w/attached gara	2009
New	Approved Basic 08-105018-BP	Plan No. Edgewood 2	2006 IRC	2 story SFR w/attached ga	2009
New	SENT PERMIT FOLDER TO RECORDS ROOM 11/26/08 DM Approved Basic 06-136130 BP 2003				
New	Approved Basic 08-108824-BP	Plan No. Brighton (2)	2006 IRC	2 Story SFR w/ attached	2009
New	Approved basic 09-100390 BP	2006 IRC	Plan# Auburn	2-story sfr w/attached ga	2009
New	Approved basic 09-100390 BP	2006 IRC	Plan# Auburn	2-story sfr w/attached ga	2009
New	Approved Basic 08-105018-BP	Plan No. Edgewood 2	2006 IRC	2 story SFR w/attached ga	2009
New	Approved Basic 08-108824-BP	Plan No. Brighton (2)	2006 IRC	2 Story SFR w/ attached	2009
New	Approved Basic 06-136135 BP	2003 IRC	Two story SFR with attached Garage	Plan: Elliston	2009
New	Approved Basic 08-108824-BP	Plan No. Brighton (2)	2006 IRC	2 Story SFR w/ attached	2009

Accessory Dwelling Units

Index # - File Name: 1.0022 - Single Family Dwellings Data\_Snohomish County.pdf

New	Approved Basic 08-105019-BP	Plan No. Glenbrook 2	2006 IRC	2 story SFR w/ attached garage	2009
New	Approved Basic 08-108824-BP	Plan No. Brighton (2)	2006 IRC	2 Story SFR w/ attached	2009
New	Approved Basic 08-108823-BP	Plan No. Summerlin (2)	2006 IRC	2 story SFR w/ attached	2009
New	Approved Basic 06-136135 BP	- 2003 IRC	Two story SFR with attached Garage	Plan: Elliston	2009
New	2-Story Single Family Residence w/ UNFINISHED basement. Engineered by Frank T. Jarnot, P.E.				2009
New	Approved Basic 08-105019-BP	Plan No. Glenbrook 2	2006 IRC	2 story SFR w/ attached garage	2009
New	Approved basic 09-100390 BP	2006 IRC	Plan# Auburn	2-story sfr w/attached ga	2009
New	Approved Basic 09-108662-BP	Plan No. 1507 A/B	2006 IRC	2 story SFR w/ attached 2 car g	2009
New	Approved Basic 09-108662-BP	Plan No. 1507 A/B	2006 IRC	2 story SFR w/ attached 2 car g	2009
New	Approved Basic 09-108662-BP	Plan No. 1507 A/B	2006 IRC	2 story SFR w/ attached 2 car g	2009
New	Approved Basic 09-108662-BP	Plan No. 1507 A/B	2006 IRC	2 story SFR w/ attached 2 car g	2009
New	Approved Basic 09-108662-BP	Plan No. 1507 A/B	2006 IRC	2 story SFR w/ attached 2 car g	2009
New	Approved Basic 09-108666-BP	Plan No. 1858 A/B	2006 IRC	2 story SFR w/ attached 2 car g	2009
New	Approved Basic 09-108666-BP	Plan No. 1858 A/B	2006 IRC	2 story SFR w/ attached 2 car g	2009
New	Approved Basic #07-107306 BP	2006 IRC	Plan B-2781	Two Story SFR w/attached garage	2009
New	Approved basic 09-103398 BP	2006 IRC	Plan# Steen Plan C	2-story sfr w/attached	2009
New	Approved basic 09-103400 BP	2006 IRC	Plan# 2818SF	2-story sfr w/attached ga	2009
New	Approved basic 09-100369 BP	Plan 1349 B	2006 IRC	2-story sfr w/attached garag	2009
New	Approved basic 09-101027 BP	2006 IRC	Plan# 1802 A	2-story sfr w/attached ga	2009
New	Approved basic 09-100370 BP	2006 IRC	Plan 1678-B	2-story sfr w/attached garag	2009
New	Approved Basic 08-111448-BP	Plan No. 1587	2006 IRC	2 story SFR w/ attached garage	2009
New	Approved basic 09-100369 BP	Plan 1349 B	2006 IRC	2-story sfr w/attached garag	2009
New	Approved basic 09-102907 BP	2006 IRC	Plan # 1608	2-story sfr w/attached gai	2009
New	Approved basic 09-108157 BP	2006 IRC	Plan# 1678-3	2-story sfr w/attached ga	2009
New	Approved basic 09-102907 BP	2006 IRC	Plan # 1608	2-story sfr w/attached gai	2009
New	Approved Basic 09-100268-BP	Plan No 1678	2006 IRC	2 story SFR w/ 2-car garag	2009
New	Approved Basic 08-111448-BP	Plan No. 1587	2006 IRC	2 story SFR w/ attached garage	2009
New	Approved Basic 08-111430-BP	Plan No 1490	2006 IRC	2 story SFR w/ attached garage	2009
New	Approved Basic # 08-100040 BP	2006 IRC	PLAN: 1349	Two story SFR with attached Garage	2009
New	Approved basic 09-102905 BP	2006 IRC	Plan# 1587	2-story sfr w/attached	2009
New	Approved Basic 09-100268-BP	Plan No 1678	2006 IRC	2 story SFR w/ 2-car garag	2009
New	Approved basic 09-100368 BP	2006 IRC	Plan# 1587-B	2-story sfr w/attached gara	2009
New	Approved Basic 09-100268 BP	Plan No 1678	2006 IRC	2 story SFR w/ 2-car garag	2009
New	Approved Basic 08-111448-BP	Plan No. 1587	2006 IRC	2 story SFR w/ attached garage	2009
New	Approved basic 09-100368 BP	2006 IRC	Plan# 1587-B	2-story sfr w/attached gara	2009
New	Approved Basic 08-111448-BP	Plan No. 1587	2006 IRC	2 story SFR w/ attached garage	2009
New	Approved basic 09-102464 BP	2006 IRC	Plan # 1910	2-story sfr w/attached gi	2009
New	Approved basic 09-101027 BP	2006 IRC	Plan# 1802 A	2-story sfr w/attached ga	2009
New	Approved Basic 08-111448-BP	Plan No. 1587	2006 IRC	2 story SFR w/ attached garage	2009
New	Approved Basic 08-111448-BP	Plan No. 1587	2006 IRC	2 story SFR w/ attached garage	2009
New	Approved Basic 08-111430-BP	Plan No 1490	2006 IRC	2 story SFR w/ attached garage	2009
New	Approved Basic # 09-100040 BP	2006 IRC	PLAN: 1349	Two story SFR with attached Garage	2009
New	Approved Basic 08-111448-BP	Plan No. 1587	2006 IRC	2 story SFR w/ attached garage	2009
New	Approved Basic 08-111430-BP	Plan No 1490	2006 IRC	2 story SFR w/ attached garage	2009
New	Approved Basic # 09-100040 BP	2006 IRC	PLAN: 1349	Two story SFR with attached Garage	2009
New	Approved Basic 08-109063-BP	Plan No. 3821-B	2006 IRC	2 story SFR w/ attached garage	2009
New	Approved Basic 08-111193-BP	Plan No. 3803-A	2006 IRC	2 story SFR w/ attached ga	2009

Accessory Dwelling Units

Index # - File Name: 1.0022 - Single Family Dwellings Data\_Snohomish County.pdf

New	Approved Basic 08-111195-BP	Plan No. 3804-AB	2006 IRC	2 story SFR w/ attached garage	2009
New	Approved Basic 08-111196-BP	Plan No. 3805-AB	2006 IRC	2 story SFR w/ attached garage	2009
New	Approved Basic 08-109067-BP	Plan No. 3823-B	2006 IRC	2 story SFR w/ attached garage	2009
New	Approved basic 09-102932 BP	2006 IRC	Plan# 3806 A/B	2-story sfr w/attached garage	2009
New	Approved Basic 08-109068-BP	Plan No. 3824-A	2006 IRC	2 story SFR w/ attached garage	2009
New	Approved Basic 08-109066-BP	Plan No. 3823-A	2006 IRC	2nd story SFR w/ attached garage	2009
New	Approved Basic 08-109064-BP	Plan No. 3822-A	2006 IRC	2 story SFR w/ attached garage	2009
New	Approved Basic 08-111195-BP	Plan No. 3804-AB	2006 IRC	2 story SFR w/ attached garage	2009
New	Approved Basic 08-111196-BP	Plan No. 3805-AB	2006 IRC	2 story SFR w/ attached garage	2009
New	Approved basic 09-104025 BP	2006 IRC	Plan# 3801/3801 opt bath B	2-story sfr w/attached garage	2009
New	Approved Basic 08-111194-BP	Plan No. 3803-B	2006 IRC	2 story SFR w/ attached garage	2009
New	Approved basic 09-102932 BP	2006 IRC	Plan# 3806 A/B	2-story sfr w/attached garage	2009
New	Approved Basic 08-109067-BP	Plan No. 3823-B	2006 IRC	2 story SFR w/ attached garage	2009
New	Approved Basic 08-109062-BP	Plan No 3821-A	2006 IRC	2 story SFR w/ attached garage	2009
New	Approved Basic 08-111193-BP	Plan No. 3803-A	2006 IRC	2 story SFR w/ attached garage	2009
New	Approved Basic 08-109063-BP	Plan No. 3821-B	2006 IRC	2 story SFR w/ attached garage	2009
New	Approved Basic 08-109064-BP	Plan No. 3822-A	2006 IRC	2 story SFR w/ attached garage	2009
New	Approved Basic 08-111193-BP	Plan No. 3803-A	2006 IRC	2 story SFR w/ attached garage	2009
New	Approved basic 09-105223 BP	2006 IRC	Plan #D-2437sf	2-story sfr w/attached garage	2009
New	Approved Basic 08-109069-BP	Plan No. 3824-B	2006 IRC	2 story SFR w/ attached garage	2009
New	1803 sf rambler with 723 sf attached garage - 2006 IRC				2009
New	Approved Basic 08-103218-BP	Plan No. 2245-02Bv2	2006 IRC	2 story SFR w/ attached garage	2009
New	Approved Basic 08-105360-BP	Plan No. 2357-02Av2	2006 IRC	2 story SFR w/ attached garage	2009
New	Approved Basic 08-103215-BP	Plan No. 2120-02Av3	2006 IRC	2 story SFR w/attached garage	2009
New	Approved Basic 08-105361-BP	Plan No 2245-02Av2	2006 IRC	2 story SFR w/attached garage	2009
New	Approved Basic 08-106996-BP	Plan No. 2368-03AB	2006 IRC	3 story SFR w/ 1st story garage	2009
New	Approved Basic 08-105361-BP	Plan No 2245-02Av2	2006 IRC	2 story SFR w/attached garage	2009
New	Approved basic 09-104862 BP	2006 IRC	Plan# 1930-02AD	2-story sfr w/attached garage	2009
New	Approved Basic 08-103215-BP	Plan No. 2120-02Av3	2006 IRC	2 story SFR w/attached garage	2009
New	2-story home w/ daylight basement				2009
New	Approved basic 09-108198 BP	2006 IRC	Plan 1841-C 3 car	2-story sfr w/attached garage	2009
New	Approved basic 09-108198 BP	2006 IRC	Plan 1841-C 3 car	2-story sfr w/attached garage	2009
New	SENT PERMIT FOLDER TO RECORDS ROOM 11/26/08 DM Approved basic 06-130552 BP				2009
New	SENT PERMIT FOLDER TO RECORDS ROOM 11/26/08 DM Approved basic 06-130541 BP				2009
New	Approved Basic 08-100937-BP	Plan No 2075 B	2006 IRC	2 story SFR w/ attached garage	2009
New	Approved Basic 07-110118-BP	2006 IRC	Plan # 3111 C	2-Story SFR w/ attached garage	2009
New	Approved Basic 08-100953-BP	Plan No 2421 B	2006 IRC	2 story SFR w/ attached garage	2009
New	Approved Basic 07-113305-BP	Plan No. 2401 C	2006 IRC	2 story SFR w/ attached garage	2009
New	Approved Basic 07-113573-BP	Plan No 2201 C	2006 IRC	2 story SFR w/ attached garage	2009
New	Approved Basic 08-100937-BP	Plan No 2075 B	2006 IRC	2 story SFR w/ attached garage	2009
New	Approved Basic 08-100953-BP	Plan No 2421 B	2006 IRC	2 story SFR w/ attached garage	2009
New	2 story SFR w/ attached garage				2009
New	New permit to final expired 07-101236-RK				2009
New	New permit to final 07-101241-RK (see 09-103497-CT)				2009
New	SENT PERMIT FOLDER TO RECORDS ROOM 11/24/08 DM Approved basic 06-132143 BP				2009
New	Approved basic 06-132144 BP	2003 IRC	Plan# 2838	2-story sfr w/attached garage	2009
New	SENT PERMIT FOLDER TO RECORDS ROOM 11/24/08 DM *Issued under tax roll # 270516-002-0				2009

Accessory Dwelling Units

Index # - File Name: 1.0022 - Single Family Dwellings Data\_Snohomish County.pdf

New	*Issued under tax roll # 270516-002-005-00*	Approved Basic 05-128615BP	2003 IRC	2	2009
New	SENT PERMIT FOLDER TO RECORDS ROOM 11/24/08 DM *Issued under tax roll # 270516-002-0				2009
New	SENT PERMIT FOLDER TO RECORDS ROOM 11/24/08 DM *Issued under tax roll # 270516-002-0				2009
New	SENT PERMIT FOLDER TO RECORDS ROOM 11/24/08 DM *Issued under tax roll # 270516-002-0				2009
New	*Issued under tax roll # 270516-002-005-00*	Approved Basic 05-128622BP	2003 IRC	2 s	2009
New	SENT PERMIT FOLDER TO RECORDS ROOM 11/24/08 DM *Issued under tax roll # 270516-002-0				2009
New	SENT PERMIT FOLDER TO RECORDS ROOM 11/24/08 DM *Issued under tax roll # 270516-002-0				2009
New	*Issued under tax roll # 270516-002-005-00*	Approved basic 06-125104 BP	2003 IRC		2009
New	SENT PERMIT FOLDER TO RECORDS ROOM 11/24/08 DM *Issued under tax roll # 270516-002-0				2009
New	SENT PERMIT FOLDER TO RECORDS ROOM 11/24/08 DM *Issued under tax roll # 270516-002-0				2009
New	Approved Basic 07-109361-BP	Builder No. 1318 C	2006 IRC/WSEC	2 story SFR w,	2009
New	Approved Basic 07-111716-BP	Plan No. 1318 A	2006 IRC / IBC	2 story SFR w attached 1 car	2009
New	Approved Basic 07-111717-BP	Plan No. 1318 B	2006 IRC/IBC	2 story SFR w/ attached 1 car g	2009
New	Approved Basic 07-109672-BP	Builder No. 1531 A	2006 IRC / WSEC	2 story SFR w/ attachi	2009
New	Approved Basic 08-100930-BP	Plan No 1618 A	2006 IRC	2 story SFR w/ attached gara	2009
New	Approved Basic 07-109125-BP	2006 IRC	Plan # 1319 A	2-story SFR w/ attached gara	2009
New	SENT PERMIT FOLDER TO RECORDS ROOM 11/26/08 DM *Issued under tax roll # 270516-002-0				2009
New	SENT PERMIT FOLDER TO RECORDS ROOM 11/21/08 DM *Issued under tax roll # 270516-002-0				2009
New	SENT PERMIT FOLDER TO RECORDS ROOM 11/26/08 DM *Issued under tax roll # 270516-002-0				2009
New	SENT PERMIT FOLDER TO RECORDS ROOM 11/26/08 DM *Issued under tax roll # 270516-002-0				2009
New	SENT PERMIT FOLDER TO RECORDS ROOM 11/26/08 DM *Issued under tax roll # 270516-002-0				2009
New	SENT PERMIT FOLDER TO RECORDS ROOM 11/26/08 DM *Issued under tax roll # 270516-002-0				2009
New	SENT PERMIT FOLDER TO RECORDS ROOM 11/26/08 DM *Issued under tax roll # 270516-002-0				2009
New	Approved Basic 07-109361-BP	Builder No. 1318 C	2006 IRC/WSEC	2 story SFR w,	2009
New	Approved Basic 07-111716-BP	Plan No. 1318 A	2006 IRC / IBC	2 story SFR w attached 1 car	2009
New	Approved Basic 07-109361-BP	Builder No. 1318 C	2006 IRC/WSEC	2 story SFR w,	2009
New	Approved Basic 07-109127-BP	2006 IRC	Plan # 1717 A	2-Story SFR w/ attached ga	2009
New	Two story home with attached 2 car Garage				2009
New	Two Story SFR with Attached Garage				2009
New	2-story Single Family Residence w/garage and decks				2009
New	Two-story SFR with attached garage - 2006 IRC				2009
New	Approved basic 09-102965 BP	2006 IRC	Plan # 5039 M	2-story sfr w/attached ga	2009
New	Approved basic 09-102957 BP	2006 IRC	Plan# 5155 B	2-story sfr w/attached	2009
New	Approved basic 09-102961 BP	2006 IRC	Plan# 4293 A	2-story sfr w/attached gar:	2009
New	2 story SFR w/ attached garage				2009
New	2 story sfr w/attached garage				2009
New	Approved Basic 07-111794	Plan No. 2472 A	2006 IRC	2 story SFR w/attached garage	2009
New	Approved Basic 07-111793-BP	Plan No. 2440B - EF	2006 IRC	2 story SFR w/ attached g	2009
New	Approved Basic 08-104585-BP	Plan No. 3036 B #2	2006 IRC	2 story SFR w/ attached ga	2009
New	Approved Basic 08-104586-BP	Plan No. 2598 AB	2006 IRC	2 story sfr w/ attached 3 car gara	2009
New	Two Story SFR withwith Basement and Attached Garage				2009
New	Approved Basic 07-111814-BP	Plan No 2734 A	2006 IRC	2 story SFR w/ attached g	2009
New	Approved Basic 05- 123059BP		2003 IRC	Plan: 2160 Two-story SFR w	2009
New	2-Story SFR w/attached garage, Utilizing foundation from Permit 07-101503-RK				2009
New	Rambler style w/garage and decks				2009
New	Two story SFR with attached Garage				2009



Accessory Dwelling Units

Index # - File Name: 1.0022 - Single Family Dwellings Data\_Snohomish County.pdf

New	Two story SFR with attached garage - 2006 IRC				2009
New	Approved Basic 08-109725-BP	Plan No. 3814-AB	2006 IRC	2 story SFR w/ attached garage	2009
New	Approved Basic 08-109063-BP	Plan No. 3821-B	2006 IRC	2 story SFR w/ attached garage	2009
New	Approved Basic 08-109068-BP	Plan No. 3824-A	2006 IRC	2 story SFR w/ attached garage	2009
New	Approved Basic 08-109724-BP	Plan No. 3813-AB	2006 IRC	2 story SFR w/ attached garage	2009
New	Approved Basic 08-109067-BP	Plan No. 3823-B	2006 IRC	2 story SFR w/ attached garage	2009
New	Approved Basic 08-109065-BP	Plan No. 3822-B	2006 IRC	2 story SFR w/ attached garage	2009
New	Approved Basic 08-109069-BP	Plan No. 3824-B	2006 IRC	2 story SFR w/ attached garage	2009
New	Approved Basic 08-109066-BP	Plan No. 3823-A	2006 IRC	2nd story SFR w/ attached garage	2009
New	Approved Basic 08-109725-BP	Plan No. 3814-AB	2006 IRC	2 story SFR w/ attached garage	2009
New	Approved Basic 08-109727-BP	Plan No. 3815-B	2006 IRC	2 story SFR w/ attached garage	2009
New	Approved basic 07-108259 BP	2006 IRC	Plan# 3026-B	2-story sfr w/attached garage	2009
New	Approved Basic 08-109064-BP	Plan No. 3822-A	2006 IRC	2 story SFR w/ attached garage	2009
New	Approved Basic 08-109069-BP	Plan No. 3824-B	2006 IRC	2 story SFR w/ attached garage	2009
New	Approved Basic 08-109066-BP	Plan No. 3823-A	2006 IRC	2nd story SFR w/ attached garage	2009
New	Approved Basic 08-109725-BP	Plan No. 3814-AB	2006 IRC	2 story SFR w/ attached garage	2009
New	Approved Basic 08-109062-BP	Plan No 3821-A	2006 IRC	2 story SFR w/ attached garage	2009
New	Approved Basic 08-109068-BP	Plan No. 3824-A	2006 IRC	2 story SFR w/ attached garage	2009
New	Approved Basic 08-109727-BP	Plan No. 3815-B	2006 IRC	2 story SFR w/ attached garage	2009
New	Approved Basic 08-109066-BP	Plan No. 3823-A	2006 IRC	2nd story SFR w/ attached garage	2009
New	Approved Basic 08-109065-BP	Plan No. 3822-B	2006 IRC	2 story SFR w/ attached garage	2009
New	Approved Basic 08-109726-BP	Plan No. 3815-A	2006 IRC	2 story SFR w/ attached garage	2009
New	Approved Basic 08-111195-BP	Plan No. 3804-AB	2006 IRC	2 story SFR w/ attached garage	2009
New	Approved Basic 08-111196-BP	Plan No. 3805-AB	2006 IRC	2 story SFR w/ attached garage	2009
New	Approved Basic 08-111190-BP	Plan No. 3801-A	2006 IRC	2 story SFR w/ attached garage	2009
New	Approved Basic 08-111193-BP	Plan No. 3803-A	2006 IRC	2 story SFR w/ attached garage	2009
New	Approved Basic 08-109724-BP	Plan No. 3813-AB	2006 IRC	2 story SFR w/ attached garage	2009
New	Approved Basic 08-109725-BP	Plan No. 3814-AB	2006 IRC	2 story SFR w/ attached garage	2009
New	Approved basic 09-102932 BP	2006 IRC	Plan# 3806 A/B	2-story sfr w/attached garage	2009
New	Approved Basic 08-111194-BP	Plan No. 3803-B	2006 IRC	2 story SFR w/ attached garage	2009
New	Approved Basic 08-111195-BP	Plan No. 3804-AB	2006 IRC	2 story SFR w/ attached garage	2009
New	Approved Basic 08-111196-BP	Plan No. 3805-AB	2006 IRC	2 story SFR w/ attached garage	2009
New	2 story SFR w/ semi-finished basement				2009
New	Approved Basic 08-109064-BP	Plan No. 3822-A	2006 IRC	2 story SFR w/ attached garage	2009
New	Approved Basic 08-109066-BP	Plan No. 3823-A	2006 IRC	2nd story SFR w/ attached garage	2009
New	Approved Basic 08-109724-BP	Plan No. 3813-AB	2006 IRC	2 story SFR w/ attached garage	2009
New	Approved Basic 08-109063-BP	Plan No. 3821-B	2006 IRC	2 story SFR w/ attached garage	2009
New	Approved Basic 08-109069-BP	Plan No. 3824-B	2006 IRC	2 story SFR w/ attached garage	2009
New	Approved Basic 08-109726-BP	Plan No. 3815-A	2006 IRC	2 story SFR w/ attached garage	2009
New	Approved Basic 08-109724-BP	Plan No. 3813-AB	2006 IRC	2 story SFR w/ attached garage	2009
New	Approved Basic 08-109725-BP	Plan No. 3814-AB	2006 IRC	2 story SFR w/ attached garage	2009
New	Approved Basic 08-107621-RK	Plan No. 1271	2006 IRC	Rambler SFR w/ attached garage	2009
New	Approved Basic 08-107542-BP	Plan No. 1786	2006 IRC	Split Level SFR w/ attached garage	2009
New	Approved Basic 08-100185-BP	Plan No. 1944	2006 IRC	2 story SFR w/attached garage	2009
New	Approved Basic 08-107621-RK	Plan No. 1271	2006 IRC	Rambler SFR w/ attached garage	2009
New	Approved Basic 08-107542-BP	Plan No. 1786	2006 IRC	Split Level SFR w/ attached garage	2009
New	Approved Basic 08-107542-BP	Plan No. 1786	2006 IRC	Split Level SFR w/ attached garage	2009

Accessory Dwelling Units

Index # - File Name: 1.0022 - Single Family Dwellings Data\_Snohomish County.pdf

New	Approved Basic 08-107621-RK	Plan No. 1271	2006 IRC	Rambler SFR w/ attached gara	2009
New	Approved Basic 08-107621-RK	Plan No. 1271	2006 IRC	Rambler SFR w/ attached gara	2009
New	Approved Basic 08-107782-BP	Plan No. 1200 Rambler	2006 IRC	Rambler w/ attached g	2009
New	Approved Basic 08-107621-RK	Plan No. 1271	2006 IRC	Rambler SFR w/ attached gara	2009
New	Approved Basic 08-107542-BP	Plan No. 1786	2006 IRC	Split Level SFR w/ attached gar	2009
New	Approved Basic 08-100185-BP	Plan No. 1944	2006 IRC	2 story SFR w/attached garage	2009
New	Approved Basic 08-107621-RK	Plan No. 1271	2006 IRC	Rambler SFR w/ attached gara	2009
New	Approved Basic 08-107542-BP	Plan No. 1786	2006 IRC	Split Level SFR w/ attached gar	2009
New	Approved Basic 08-107621-RK	Plan No. 1271	2006 IRC	Rambler SFR w/ attached gara	2009
New	Approved Basic 08-107542-BP	Plan No. 1786	2006 IRC	Split Level SFR w/ attached gar	2009
New	Approved Basic 08-107621-RK	Plan No. 1271	2006 IRC	Rambler SFR w/ attached gara	2009
New	SENT PERMIT FOLDER TO RECORDS ROOM 12/01/08 DM *Issued under tax roll # 005380-000-1				2009
New	Approved Basic 08-107542-BP	Plan No. 1786	2006 IRC	Split Level SFR w/ attached gar	2009
New	Approved Basic 08-100185-BP	Plan No. 1944	2006 IRC	2 story SFR w/attached garage	2009
New	Approved basic 07-112026 BP	2006 IRC	Plan# 1339 B	Rambler sfr w/attached ga	2009
New	Approved Basic 08-107621-RK	Plan No. 1271	2006 IRC	Rambler SFR w/ attached gara	2009
New	Approved Basic 08-107621-RK	Plan No. 1271	2006 IRC	Rambler SFR w/ attached gara	2009
New	Approved Basic 08-107621-RK	Plan No. 1271	2006 IRC	Rambler SFR w/ attached gara	2009
New	Approved Basic 08-107621-RK	Plan No. 1271	2006 IRC	Rambler SFR w/ attached gara	2009
New	Approved Basic 08-107542-BP	Plan No. 1786	2006 IRC	Split Level SFR w/ attached gar	2009
New	2-story sfr w/attached garage				2009
New	2-story w/unfinished basement and covered porch				2009
New	SENT PERMIT FOLDER TO RECORDS ROOM 12/01/08 DM 40 ft X 53 ft Triple Wide MH				2009
New	Approved basic 07-109634 BP	2006 IRC	Plan# 3041/3062	2-story sfr w/attache	2009
New	Approved basic 07-109644 BP	2006 IRC	Plan# 2968	2-story sfr w/attached garage w/ bon	2009
New	Approved Basic No. 07-113006-RK	Builder Plan No 3514	2006 IRC	2 story SFR w/ attac	2009
New	Approved basic 07-106482BP	2006 IRC	Plan# 3098	2-story sfr w/attached }	2009
New	Approved Basic 08-102140-BP	Plan No. 2207	2006 IRC	3 story w/ attached garage and se	2009
New	Approved basic 09-105969 BP	2006 IRC	Plan# 1914	2-story sfr w/attached	2009
New	Approved basic 07-111257BP	2006 IRC	Plan# 1807	2-story sfr w/attached garag	2009
New	Approved basic 07-111257BP	2006 IRC	Plan# 1807	2-story sfr w/attached garag	2009
New	Approved basic 07-111257BP	2006 IRC	Plan# 1807	2-story sfr w/attached garag	2009
New	Approved basic 07-111255 BP	2006 IRC	Plan# 1785	2-story sfr w/attached gar	2009
New	Approved Basic 07-111859 BP	Plan Number 1388	2006 IRC	1 story w/ lo	2009
New	Approved Basic 08-105360-BP	Plan No. 2357-02Av2	2006 IRC	2 story SFR w/ attached	2009
New	Approved Basic 08-103218-BP	Plan No. 2245-02Bv2	2006 IRC	2 story SFR w/ attached	2009
New	Application extended per M.McCrory see Mick if questions**EXPIRED APPLICATION OVER 18 M				2009
New	Approved Basic 07-112055-BP	2006 IRC	Plan # AG2100-02-B	2-Story SFR w/ ati	2009
New	Two story home w/ attached 3-car garage				2009
New	Approved Basic 07-114877-BP	Plan No C508A&B	2006 IRC	2 story SFR w/ attached 2 or	2009
New	Approved Basic 07-114993-BP	Plan No C501B	2006 IRC	2 story SFR w/ attached garage	2009
New	Approved Basic 08-105654-BP	Plan No. 3387	2006 IRC	2 story SFR w/ attached garage	2009
New	Approved Basic 08-108054-BP	Plan No. 2575	2006 IRC	2 story SFR w/ attached garage	2009
New	Approved Basic 08-105929-BP	Plan No. 3062	2006 IRC	2 stroy SFR w/ attached garage	2009
New	Approved basic 09-103593 BP	2006 IRC	Plan# Juno A	Rambler w/attached gar	2009
New	Approved basic 09-103594 BP	2006 IRC	Plan# Jupiter	Rambler w/attached gara	2009
New	Two-story residence with attached garage				2009

Accessory Dwelling Units

Index # - File Name: 1.0022 - Single Family Dwellings Data\_Snohomish County.pdf

New	Approved basic 09-105682 BP	2006 IRC	Plan# C 276.1 MRL	2-story sfr w/attached	2009
New	2 story sfr w/attached garage				2009
New	Approved basic 09-103730 BP	2006 IRC	Plan# C 274.1MRL A	2-story sfr w/attached ga	2009
New	Approved basic 09-104396 BP	2006 IRC	Plan# C 311	2-story sfr w/attached ga	2009
New	Approved basic 09-104396 BP	2006 IRC	Plan# C 311	2-story sfr w/attached ga	2009
New	Building permit for a new 2 story home with attached 2 car garage				2009
New	Approved Basic 08-105360-BP	Plan No. 2357-02Av2	2006 IRC	2 story SFR w/ attached	2009
New	2-story sfr w/unfinished basement attached garage			STOP WORK POSTED FOR FOUNDATION WI	2009
New	2 story SFR w/unfinished basement and garage				2009
New	Approved Basic 08-103216-BP	Plan No. 2120-02Bv3	2006 IRC	2 story SFR w/ attached garag	2009
New	Approved Basic 07-112054-BP	2006 IRC	Plan # AG2100-02A	2-Story SFR w/ att	2009
New	Approved Basic 08-103215-BP	Plan No. 2120-02Av3	2006 IRC	2 story SFR w/attached	2009
New	Approved Basic 08-109067-BP	Plan No. 3823-B	2006 IRC	2 story SFR w/ attached garage	2009
New	Approved Basic 08-109724-BP	Plan No. 3813-AB	2006 IRC	2 story SFR w/ attached garage	2009
New	Approved Basic 08-109063-BP	Plan No. 3821-B	2006 IRC	2 story SFR w/ attached garage	2009
New	Approved Basic 08-109727-BP	Plan No. 3815-B	2006 IRC	2 story SFR w/ attached garage	2009
New	Approved basic 07-108259 BP	2006 IRC	Plan# 3026-B	2-story sfr w/attached ga	2009
New	Approved Basic 08-109726-BP	Plan No. 3815-A	2006 IRC	2 story SFR w/ attached garage	2009
New	Approved Basic 08-109725-BP	Plan No. 3814-AB	2006 IRC	2 story SFR w/ attached garag	2009
New	Approved Basic 08-109063-BP	Plan No. 3821-B	2006 IRC	2 story SFR w/ attached garage	2009
New	Approved basic 07-108257 BP	2006 IRC	Plan# 3026-A	2-story sfr w/attached ga	2009
New	Approved Basic 08-109725-BP	Plan No. 3814-AB	2006 IRC	2 story SFR w/ attached garag	2009
New	Approved Basic 08-109069-BP	Plan No. 3824-B	2006 IRC	2 story SFR w/ attached garage	2009
New	Two story home with attached garage				2009
New	Approved Basic #07-110629 BP	2006 IRC	Plan: Glacier B	Two Story SFR w/attached garage	2009
New	Approved Basic #07-113358 BP	2006 IRC	Plan: Madison B	Two Story SFR w/attached garag	2009
New	Approved Basic #07-110629 BP	2006 IRC	Plan: Glacier B	Two Story SFR w/attached garage	2009
New	Approved Basic #07-113358 BP	2006 IRC	Plan: Madison B	Two Story SFR w/attached garag	2009
New	Approved Basic 08-110791-BP	Plan No. Baker 3160 B	2006 IRC	2 story SFR w/ attached ga	2009
New	Approved basic 06-133592 BP	2003 IRC	Plan# Shasta Gable	2-story sfr w/attached ga	2009
New	Approved Basic #07-113348 BP	2006 IRC	Plan: Crestone II B	Two Story SFR w/attached gar	2009
New	Approved basic 09-103521 BP	2006 IRC	Plan# Skagit A	2-story sfr w/attached gar	2009
New	Approved Basic 08-110789-BP	Plan No. Cascade 3184 B	2006 IRC	2 story SFR w/ attached ga	2009
New	Approved Basic #07-105838 BP	Plan: Langley Hip II A (I)	2003 IRC	Two Story SFR	2009
New	Approved basic 09-103512 BP	2006 IRC	Plan# Olympic B	2-story sfr w/attached g	2009
New	Approved basic 06-134177 BP	2003 IRC	Plan# Waterton Gable B (I)	2-story sfr w/attac	2009
New	Approved basic 09-103525 BP	2006 IRC	Plan# Franklin B	2-story sfr w/attached ga	2009
New	Approved Basic #07-113367 BP	2006 IRC	Plan: Shasta B	Two Story SFR w/attached garag	2009
New	Approved Basic #07-113348 BP	2006 IRC	Plan: Crestone II B	Two Story SFR w/attached gar	2009
New	Approved Basic 08-110788-BP	Plan No. Cascade 3184 A	2006 IRC	2 story SFR w/ attached	2009
New	Approved Basic #07-113358 BP	2006 IRC	Plan: Madison B	Two Story SFR w/attached garag	2009
New	Approved Basic #07-113347 BP	2006 IRC	Plan: Crestone II A	Two Story SFR w/attached gar	2009
New	Approved Basic 08-110790-BP	Plan No. Baker 3105 A	2006 IRC	3 story SFR w/attached gar	2009
New	Approved basic 09-101958 BP	2006 IRC	Plan# Evans A	2-story sfr w/attached gara	2009
New	Approved Basic 09-101959 BP	2006 IRC	Plan# Evans B	2-story sfr w/attached gara	2009
New	Approved basic 09-101956 BP	2006 IRC	Plan# Easton B	2-story sfr w/attached ga	2009
New	Approved basic 09-102243 BP	2006 IRC	Plan# Jameson A	2-story sfr w/attached g	2009

Accessory Dwelling Units

Index # - File Name: 1.0022 - Single Family Dwellings Data\_Snohomish County.pdf

New	Approved basic 09-102239 BP	2006 IRC	Plan# Kellogg A	2-story sfr w/attached ga	2009
New	Approved basic 09-101963 BP	2006 IRC	Plan # Douglas A	2-story sfr w/attached g	2009
New	Approved basic 09-101955 BP	2006 IRC	Plan# Easton A	2-story sfr w/attached ga	2009
New	Approved basic 09-102246 BP	2006 IRC	Plan# Lincoln A	2-story sfr /attached gara	2009
New	SENT PERMIT FOLDER TO RECORDS ROOM 11/04/08 DM Approved Basic 07-113887-BP Plan				2009
New	SENT PERMIT FOLDER TO RECORDS ROOM 11/04/08 DM Approved Basic 07-113891-BP Plan				2009
New	SENT PERMIT FOLDER TO RECORDS ROOM 11/04/08 DM Approved Basic 07-113892-BP Plan				2009
New	SENT PERMIT FOLDER TO RECORDS ROOM 11/04/08 DM Approved Basic 07-113891-BP Plan				2009
New	SENT PERMIT FOLDER TO RECORDS ROOM 11/04/08 DM Approved Basic 07-113887-BP Plan				2009
New	SENT PERMIT FOLDER TO RECORDS ROOM 11/04/08 DM Approved Basic 07-113892-BP Plan				2009
New	SENT PERMIT FOLDER TO RECORDS ROOM 11/04/08 DM Approved Basic 07-113887-BP Plan				2009
New	Approved Basic 07-113892-BP	Plan No. Aconite I	2006 IRC	2 story SFR w/ attached gara	2009
New	Approved Basic 07-113887-BP	Plan No. Iris I	2006 IRC	2 story SFR w/ attached garage	2009
New	SENT PERMIT FOLDER TO RECORDS ROOM 11/04/08 DM Approved Basic 07-113892-BP Plan				2009
New	SENT PERMIT FOLDER TO RECORDS ROOM 11/04/08 DM Approved Basic 07-113887-BP Plan				2009
New	SENT PERMIT FOLDER TO RECORDS ROOM 11/04/08 DM Approved Basic 07-113892-BP Plan				2009
New	Approved Basic 07-113892-BP	Plan No. Aconite I	2006 IRC	2 story SFR w/ attached gara	2009
New	Approved Basic 07-113887-BP	Plan No. Iris I	2006 IRC	2 story SFR w/ attached garage	2009
New	Approved Basic 07-113892-BP	Plan No. Aconite I	2006 IRC	2 story SFR w/ attached gara	2009
New	Approved Basic 07-113891-BP	Plan No. Anemone	2006 IRC	2 story SFR w/ attached g	2009
New	Rambler with unfinished basement and attached two-car garage				2009
New	Approved Basic 09-100748-BP	Plan # W2506	2006 IBC	2-Story SFR w/ 3-car garage	2009
New	Approved Basic 09-100748-BP	Plan # W2506	2006 IBC	2-Story SFR w/ 3-car garage	2009
New	Approved basic 09-100749 BP	2006 IRC	Plan 2058	Rambler style sfr w/attached ga	2009
New	Approved basic 09-102881 BP	2006 IRC	Plan# 628	2-story sfr w/attached garage	2009
New	Approved basic 09-102879 BP	2006 IRC	Plan# 627	2-story sfr w/attached garage	2009
New	Approved basic 09-102879 BP	2006 IRC	Plan# 627	2-story sfr w/attached garage	2009
New	Approved basic 09-102879 BP	2006 IRC	Plan# 627	2-story sfr w/attached garage	2009
New	Approved basic 09-102879 BP	2006 IRC	Plan# 627	2-story sfr w/attached garage	2009
New	Approved basic 09-102879 BP	2006 IRC	Plan# 627	2-story sfr w/attached garage	2009
New	Approved basic 09-102879 BP	2006 IRC	Plan# 627	2-story sfr w/attached garage	2009
New	Approved basic 09-102881 BP	2006 IRC	Plan# 628	2-story sfr w/attached garage	2009
New	Approved basic 09-102881 BP	2006 IRC	Plan# 628	2-story sfr w/attached garage	2009
New	Approved basic 09-102881 BP	2006 IRC	Plan# 628	2-story sfr w/attached garage	2009
New	Approved basic 09-102881 BP	2006 IRC	Plan# 628	2-story sfr w/attached garage	2009
New	Approved basic 09-102881 BP	2006 IRC	Plan# 628	2-story sfr w/attached garage	2009
New	Approved basic 09-102881 BP	2006 IRC	Plan# 628	2-story sfr w/attached garage	2009
New	Approved basic 09-102881 BP	2006 IRC	Plan# 628	2-story sfr w/attached garage	2009
New	Approved basic 09-102881 BP	2006 IRC	Plan# 628	2-story sfr w/attached garage	2009
New	Approved basic 08-100624 BP	2006 IRC	Plan# 625-2E	2-story sfr w/attached gara	2009
New	Approved basic 08-100625 BP	2006 IRC	Plan# 625-2F	2-story sfr w/attached garage	2009
New	Approved basic 08-100623 BP	2006 IRC	Plan# 625-2D	2-story sfr w/attached gara	2009
New	Approved basic 08-100624 BP	2006 IRC	Plan# 625-2E	2-story sfr w/attached gara	2009
New	Approved basic 08-100624 BP	2006 IRC	Plan# 625-2E	2-story sfr w/attached gara	2009
New	Approved basic 08-100625 BP	2006 IRC	Plan# 625-2F	2-story sfr w/attached garage	2009
New	Approved basic 08-100623 BP	2006 IRC	Plan# 625-2D	2-story sfr w/attached gara	2009
New	Approved basic 08-100625 BP	2006 IRC	Plan# 625-2F	2-story sfr w/attached garage	2009

Accessory Dwelling Units

Index # - File Name: 1.0022 - Single Family Dwellings Data\_Snohomish County.pdf

New	Approved basic 08-100621 BP	2006 IRC	Plan# 623-2D, E	3-story sfr w/attached gar	2009
New	Approved basic 08-100621 BP	2006 IRC	Plan# 623-2D, E	3-story sfr w/attached gar	2009
New	Approved basic 08-100621 BP	2006 IRC	Plan# 623-2D, E	3-story sfr w/attached gar	2009
New	Approved basic 08-100620 BP	2006 IRC	Plan# 621-1D	2-story sfr w/attached gara	2009
New	Approved basic 08-100620 BP	2006 IRC	Plan# 621-1D	2-story sfr w/attached gara	2009
New	Approved basic 08-100621 BP	2006 IRC	Plan# 623-2D, E	3-story sfr w/attached gar	2009
New	Approved basic 08-100621 BP	2006 IRC	Plan# 623-2D, E	3-story sfr w/attached gar	2009
New	Approved basic 08-100621 BP	2006 IRC	Plan# 623-2D, E	3-story sfr w/attached gar	2009
New	Approved basic 08-100620 BP	2006 IRC	Plan# 621-1D	2-story sfr w/attached gara	2009
New	Approved basic 08-100621 BP	2006 IRC	Plan# 623-2D, E	3-story sfr w/attached gar	2009
New	Approved basic 08-100620 BP	2006 IRC	Plan# 621-1D	2-story sfr w/attached gara	2009
New	Approved basic 08-100621 BP	2006 IRC	Plan# 623-2D, E	3-story sfr w/attached gar	2009
New	Two story SFR with attached Garage				2009
New	Approved basic 09-100749 BP	2006 IRC	Plan 2058	Rambler style sfr w/attached ga	2009
New	2-story sfr w/attached garage				2009
New	2-story sfr w/attached garage				2009
New	Approved basic 09-103296 BP	2006 IRC	Plan# 1996 A	2 - story sfr w/attached ga	2009
New	Approved basic 07-110786 BP	2006 IRC	Plan# 1500	Ramber style sfr w/attache	2009
New	Approved basic 07-110791 BP	2006 IRC	Plan# 2272	2-story sfr w/attached garag	2009
New	Approved basic 09-103296 BP	2006 IRC	Plan# 1996 A	2 - story sfr w/attached ga	2009
New	Approved basic 09-103298 BP	2006 IRC	Plan# 2744	2-story sfr w/attached {	2009
New	Approved basic 09-103298 BP	2006 IRC	Plan# 2744	2-story sfr w/attached {	2009
New	Approved Basic 08-106589-BP	Plan No. 2402	2006 IRC	2 story SFR w/ attached gara	2009
New	Approved basic 07-110789 BP	2006 IRC	Plan# 2537	2-story sfr w/attached garage	2009
New	Approved basic 07-110791 BP	2006 IRC	Plan# 2272	2-story sfr w/attached garag	2009
New	Approved basic 07-108504 BP	2006 IRC	Plan# 2521	2-story sfr w/attached garage	2009
New	Approved Basic 07-108137-BP	Contractor Plan No 3078		2 story SFR w/ attached gara	2009
New	2-story Duplex w/finished basement				2009
New	Approved Basic 08-105709-BP	Plan No. 2280	2006 IRC	2 story SFR w/attached garage	2009
New	Approved Basic 08-105709-BP	Plan No. 2280	2006 IRC	2 story SFR w/attached garage	2009
New	Approved Basic 08-105709-BP	Plan No. 2280	2006 IRC	2 story SFR w/attached garage	2009
New	Approved Basic 08-103286-BP	Plan No 2744	2006 IRC	2 story SFR w/ attached garage	2009
New	Approved Basic 08-103292-BP	Plan No 2607	2006 IRC	2 story SFR w/ attached garge	2009
New	Approved Basic 08-109204-BP	Plan No. 1570-02AB	2006 IRC	2 story SFR w/ attached gara	2009
New	Approved Basic 08-111194-BP	Plan No. 3803-B	2006 IRC	2 story SFR w/ attached {	2009
New	Approved Basic 08-111195-BP	Plan No. 3804-AB	2006 IRC	2 story SFR w/ attached g;	2009
New	Approved Basic 08-111193-BP	Plan No. 3803-A	2006 IRC	2 story SFR w/ attached ga	2009
New	Approved basic 09-102932 BP	2006 IRC	Plan# 3806 A/B	2-story sfr w/attached gar	2009
New	Approved Basic 08-111196-BP	Plan No. 3805-AB	2006 IRC	2 story SFR w/ attached ga	2009
New	Approved basic 09-104024 BP	2006 IRC	Plan# 3801/3801 opt bath-A	2-story sfr w/attach	2009
New	Approved Basic 08-111195-BP	Plan No. 3804-AB	2006 IRC	2 story SFR w/ attached g;	2009
New	Approved Basic 08-111193-BP	Plan No. 3803-A	2006 IRC	2 story SFR w/ attached ga	2009
New	Approved Basic 08-111195-BP	Plan No. 3804-AB	2006 IRC	2 story SFR w/ attached g;	2009
New	Approved basic 09-104025 BP	2006 IRC	Plan# 3801/3801 opt bath B	2-story sfr w/a	2009
New	Approved basic 09-102932 BP	2006 IRC	Plan# 3806 A/B	2-story sfr w/attached gar	2009
New	Approved Basic 08-111195-BP	Plan No. 3804-AB	2006 IRC	2 story SFR w/ attached g;	2009
New	Approved Basic 08-111194-BP	Plan No. 3803-B	2006 IRC	2 story SFR w/ attached {	2009

Accessory Dwelling Units

Index # - File Name: 1.0022 - Single Family Dwellings Data\_Snohomish County.pdf

New	Approved Basic 08-111196-BP	Plan No. 3805-AB	2006 IRC	2 story SFR w/ attached ga	2009
New	Approved basic 09-102932 BP	2006 IRC	Plan# 3806 A/B	2-story sfr w/attached gar	2009
New	Approved Basic 08-111193-BP	Plan No. 3803-A	2006 IRC	2 story SFR w/ attached ga	2009
New	Approved Basic 08-111195-BP	Plan No. 3804-AB	2006 IRC	2 story SFR w/ attached g	2009
New	Approved basic 09-104024 BP	2006 IRC	Plan# 3801/3801 opt bath-A	2-story sfr w/attach	2009
New	Approved Basic 08-111196-BP	Plan No. 3805-AB	2006 IRC	2 story SFR w/ attached ga	2009
New	Approved Basic 08-111195-BP	Plan No. 3804-AB	2006 IRC	2 story SFR w/ attached g	2009
New	Approved Basic 08-111194-BP	Plan No. 3803-B	2006 IRC	2 story SFR w/ attached g	2009
New	SFR w/ attached garage				2009
New	Two-story residence with attached garage				2009
New	Two-story residence with attached garage				2009
New	2-story Single Family Residence w/garage				2009
New	Two-story residence with attached garage				2009
New	Two story SFR with attached Garage				2009
New	Three Story SFR - 1st Floor Garage; NSF Check - accept cash or credit card only				2009
New	Approved basic 09-103375 BP	2006 IRC	Plan# 2224	2-story sfr w/attached gara	2009
New	Approved basic 09-103392 BP	2006 IRC	Plan #2235	2-story sfr w/attached gar	2009
New	Approved basic 09-103603 BP	2006 IRC	Plan# 2063	2-story sfr w/attached gara	2009
New	Approved basic 09-103057 BP	2009 IRC	Plan# 2186	2-story sfr w/attached gar	2009
New	Approved basic 09-103392 BP	2006 IRC	Plan #2235	2-story sfr w/attached gar	2009
New	Approved basic 09-103375 BP	2006 IRC	Plan# 2224	2-story sfr w/attached gara	2009
New	Approved basic 09-103603 BP	2006 IRC	Plan# 2063	2-story sfr w/attached gara	2009
New	Approved basic 09-103057 BP	2009 IRC	Plan# 2186	2-story sfr w/attached gar	2009
New	Approved basic 09-103375 BP	2006 IRC	Plan# 2224	2-story sfr w/attached gara	2009
New	Approved basic 09-102715 BP	2006 IRC	Plan #2377	2-story sfr w/attached	2009
New	Approved basic 09-103392 BP	2006 IRC	Plan #2235	2-story sfr w/attached gar	2009
New	Approved basic 09-103057 BP	2009 IRC	Plan# 2186	2-story sfr w/attached gar	2009
New	Approved basic 09-103375 BP	2006 IRC	Plan# 2224	2-story sfr w/attached gara	2009
New	Approved basic 09-103603 BP	2006 IRC	Plan# 2063	2-story sfr w/attached gara	2009
New	Approved basic 09-102715 BP	2006 IRC	Plan #2377	2-story sfr w/attached	2009
New	Approved basic 09-106006 BP	2006 IRC	Plan# 1996	2-story sfr w/attached garage	2009
New	Approved basic 09-103057 BP	2009 IRC	Plan# 2186	2-story sfr w/attached gara	2009
New	Approved basic 09-103392 BP	2006 IRC	Plan #2235	2-story sfr w/attached gar	2009
New	Approved basic 09-102715 BP	2006 IRC	Plan #2377	2-story sfr w/attached	2009
New	approved basic 09-106006 BP	2006 IRC	Plan# 1996	2-story sfr w/attached garage	2009
New	Approved basic 09-106006 BP	2006 IRC	Plan# 1996	2-story sfr w/attached garage	2009
New	Approved basic 09-103057 BP	2009 IRC	Plan# 2186	2-story sfr w/attached gara	2009
New	Approved basic 09-104039 BP	2006 IRC	Plan# 2370 SW FLR	2-story sfr w/attached g	2009
New	Approved basic 09-104039 BP	2006 IRC	Plan# 2370 SW FLR	2-story sfr w/attached g	2009
New	Approved basic 09-104038 BP	2006 IRC	Plan# 2217 SW FLR	2-story sfr w/attached g	2009
New	Approved basic 09-104037 BP	2006IRC	Plan# 2023 SW FLR	2-story sfr w/attached g	2009
New	Approved basic 09-104039 BP	2006 IRC	Plan# 2370 SW FLR	2-story sfr w/attached g	2009
New	Approved basic 09-104040 BP	2006 IRC	Plan# 2493 SW FLR	2-story sfr w/attache	2009
New	Approved basic 07-114693 BP	2006 IRC	Plan# 2493	2-story sfr w/attached garage	2009
New	Approved basic 09-102802 BP	BP 2006 IRC	Plan#2023 SW	2-story sfr w/attached g	2009
New	Approved basic 09-104037 BP	2006IRC	Plan# 2023 SW FLR	2-story sfr w/attached g	2009
New	Approved basic 09-104038 BP	2006 IRC	Plan# 2217 SW FLR	2-story sfr w/attached g	2009

Accessory Dwelling Units

Index # - File Name: 1.0022 - Single Family Dwellings Data\_Snohomish County.pdf

New	Approved basic 07-114693 BP	2006 IRC	Plan# 2493	2-story sfr w/attached garage	2009
New	Approved 09-102803 BP	2006 IRC	Plan# 1987	2-story sfr w/attached garage	2009
New	Rambler style sfr w/attached garage				2009
New	Approved Basic 08-111009 BP	Plan: 1633	2006 IRC	1633 sq ft Rambler with attached Ga	2009
New	Approved Basic 08-111419-BP	Plan No. 1402	2006 IRC	Rambler style SFR w/ attached g	2009
New	Rambler style sfr no garage NSF Check - accept only cash or credit card; see other open permits				2009
New	Two-story residence with attached garage				2009
New	Two-story residence with attached garage				2009
New	2 story sfr w/attached garage- see other open permits				2009
New	Two-story residence with attached garage				2009
New	2 story sfr w/attached garage NSF CHECK - ACCOUNT TURNED OVER TO COLLECTIONS - DO NOT				2009
New	Approved basic 09-100243 BP	2-story sfr w/attached garage 3 car option			2009
New	Approved Basic 08-107319-BP	Plan No 2664	2006 IRC	2 story SFR w/attached garage	2009
New	Approved basic 09-100225 BP	2006 IRC	Plan# 2131	Rambler style sfr w/attached gara	2009
New	Approved Basic 08-107316-BP	Plan No. 2426	2006 IRC	two story SFR w/ attached garage	2009
New	Approved basic 09-100225 BP	2006 IRC	Plan# 2131	Rambler style sfr w/attached gara	2009
New	2009 Palm Harbor Mobile Home				2009
New	Approved Basic 08-107316-BP	Plan No. 2426	2006 IRC	two story SFR w/ attached garage	2009
New	Approved basic 09-107144 BP	2006 IRC	Plan# Stevens A	2-story sfr w/attached gara	2009
New	Approved basic 09-107145 BP	2006 IRC	Plan# Stevens B	2-story sfr w/attached g	2009
New	Two-story residence with daylight basement				2009
New	2-Story Single Family Residence w/ garage and covered deck				2009
New	Approved Basic 09-100027-BP	Plan No. 1239	2006 IRC	2 story SFR w/ attached garage	2009
New	Approved Basic 09-100026-BP	Plan No. 1529	2006 IRC	2 story SFR w/ attached garage	2009
New	Approved basic 09-101300 BP	2006 IRC	Plan# 1415	2 story sfr w/attached garag	2009
New	Approved basic 09-101300 BP	2006 IRC	Plan# 1415	2 story sfr w/attached garag	2009
New	Approved Basic 09-100026-BP	Plan No. 1529	2006 IRC	2 story SFR w/ attached garage	2009
New	Approved Basic #07-113350 BP	2006 IRC	Plan: Hazelwood B	Two Story SFR w/attached gar	2009
New	Approved basic 09-108142 BP	2006 IRC	Plan#Omak II-A	2-story sfr w/attached g	2009
New	Approved Basic #07-113358 BP	2006 IRC	Plan: Madison B	Two Story SFR w/attached garag	2009
New	Approved basic 09-104646 BP	2006 IRC	Plan# Dayton A	2-story sfr w/attached ga	2009
New	Approved Basic #07-113349 BP	2006 IRC	Plan: Hazelwood A	Two Story SFR w/attached ga	2009
New	Approved basic 09-100643 BP	2006 IRC	Plan Granite B	2-story sfr w/attached garag	2009
New	Approved Basic #07-113350 BP	2006 IRC	Plan: Hazelwood B	Two Story SFR w/attached gar	2009
New	Approved basic 09-100642 BP	2006 IRC	Plan# Granite A	2-story sfr w/attached gar	2009
New	1-story sfr w/attached garage				2009
New	Approved Basic #07-113359 BP	2006 IRC	Plan: Mansfield A	Two Story SFR w/attached gara	2009
New	Approved basic 09-104646 BP	2006 IRC	Plan# Dayton A	2-story sfr w/attached ga	2009
New	Approved Basic #07-113371 BP	2006 IRC	Plan: Wrangell B	Two Story SFR w/attached gar	2009
New	Approved basic 09-102243 BP	2006 IRC	Plan# Jameson A	2-story sfr w/attached g	2009
New	Approved Basic 09-100026-BP	Plan No. 1529	2006 IRC	2 story SFR w/ attached garage	2009
New	Approved Basic 09-100026-BP	Plan No. 1529	2006 IRC	2 story SFR w/ attached garage	2009
New	Approved basic 09-101300 BP	2006 IRC	Plan# 1415	2 story sfr w/attached garag	2009
New	Approved Basic 09-100026-BP	Plan No. 1529	2006 IRC	2 story SFR w/ attached garage	2009
New	Approved Basic 09-100026-BP	Plan No. 1529	2006 IRC	2 story SFR w/ attached garage	2009
New	Approved basic 09-101300 BP	2006 IRC	Plan# 1415	2 story sfr w/attached garag	2009
New	Approved Basic 09-100026-BP	Plan No. 1529	2006 IRC	2 story SFR w/ attached garage	2009

Accessory Dwelling Units

Index # - File Name: 1.0022 - Single Family Dwellings Data\_Snohomish County.pdf

New	Two-story home with attached 2 car garage				2009
New	Approved basic 09-107144 BP	2006 IRC	Plan# Stevens A	2-story sfr w/attached garage	2009
New	Approved basic 09-107145 BP	2006 IRC	Plan# Stevens B	2-story sfr w/attached garage	2009
New	Approved basic 09-106956 BP	2006 IRC	Plan# Whitman A	2-story sfr w/attached garage	2009
New	2-story sfr w/attached garage				2009
New	2-story Single Family Residence w/garage and covered deck/porch				2009
New	Approved Basic 09-100026-BP	Plan No. 1529	2006 IRC	2 story SFR w/ attached garage	2009
New	Approved basic 09-101300 BP	2006 IRC	Plan# 1415	2 story sfr w/attached garage	2009
New	Approved basic 09-101299 BP	2006 IRC	Plan# 1372	Rambler style sfr w/attached garage	2009
New	Two-story residence				2009
New	Approved basic 09-103611 BP	2006 IRC	Plan# 1409	2-story sfr w/attached garage	2009
New	Approved basic 09-106889 BP	2006 IRC	Plan# 1707-3	2-story sfr w/attached garage	2009
New	Rambler Style sfr w/attached garage				2009
New	1730 sq ft Rambler with attached Garage				2009
New	Two story residence				2009
New	Approved basic 09-103886 BP	2006 IRC	Plan# 3138-3	2-story sfr w/attached garage	2009
New	Approved basic 09-106925 BP	2006 IRC	Plan# 3431-3	2-story sfr w/attached garage	2009
New	Approved basic 09-104171 BP	2006 IRC	Plan# 3282 A	2-story sfr w/attached garage	2009
New	Approved basic 09-106920 BP	2006 IRC	Plan# 3101-3	2-story sfr w/attached garage	2009
New	Approved basic 09-108148 BP	2006 IRC	Plan# 3370	2-story sfr w/attached garage	2009
New	2 story sfr w/attached garage				2009
New	2-story sfr w/attached garage				2009
New	2 story SFR w/ attached garage				2009
New	Approved basic 09-104173 BP	2006 IRC	Plan# 3008 A	2-story sfr w/attached garage	2009
New	Approved basic 09-103889 BP	2006 IRC	Plan#2943	2-story sfr w/attached garage	2009
New	Approved basic 09-104175 BP	2006 IRC	Plan# 2894 A	2-story sfr w/attached garage	2009
New	Approved basic 09-108155 BP	2006 IRC	Plan# 4141	2-story sfr w/attached garage	2009
New	Approved basic 09-108148 BP	2006 IRC	Plan# 3370	2-story sfr w/attached garage	2009
New	2 story home with basement and attached garage				2009
New	Approved basic 07-114693 BP	2006 IRC	Plan# 2493	2-story sfr w/attached garage	2009
New	Approved Basic 07-114694-BP	2006 IRC	Plan # 2370	2-Story SFR w/ attached garage	2009
New	Approved Basic 07-114694-BP	2006 IRC	Plan # 2370	2-Story SFR w/ attached garage	2009
New	Approved basic 07-114693 BP	2006 IRC	Plan# 2493	2-story sfr w/attached garage	2009
New	Approved basic 07-114693 BP	2006 IRC	Plan# 2493	2-story sfr w/attached garage	2009
New	Approved basic 07-114691 BP	2006 IRC	Plan#2023	2-story sfr w/attached garage	2009
New	Approved Basic 07-114694-BP	2006 IRC	Plan # 2370	2-Story SFR w/ attached garage	2009
New	Approved Basic 07-114694-BP	2006 IRC	Plan # 2370	2-Story SFR w/ attached garage	2009
New	Approved basic 09-106105 BP	2006 IRC	Plan#2565A2F	2-story sfr w/attached garage	2009
New	Approved basic 09-106103 BP	2006 IRC	Plan# 2590D2F	2-story sfr w/attached garage	2009
New	Approved basic 09-106141 BP	2006 IRC	Plan# 2645B3	2-story sfr w/attached garage	2009
New	Approved basic 09-106105 BP	2006 IRC	Plan#2565A2F	2-story sfr w/attached garage	2009
New	Approved basic 09-106103 BP	2006 IRC	Plan# 2590D2F	2-story sfr w/attached garage	2009
New	Approved basic 09-106141 BP	2006 IRC	Plan# 2645B3	2-story sfr w/attached garage	2009
New	Approved basic 09-106103 BP	2006 IRC	Plan# 2590D2F	2-story sfr w/attached garage	2009
New	Approved basic 09-106141 BP	2006 IRC	Plan# 2645B3	2-story sfr w/attached garage	2009
New	Special inspection for Construction Testing & Inspections filed with 09-108304 Bldg M unit 30				2009
New	Special inspection for Construction Testing & Inspections filed with 09-108304 Bldg M unit 31				2009



Accessory Dwelling Units

Index # - File Name: 1.0022 - Single Family Dwellings Data\_Snohomish County.pdf

New	Special inspection for Construction Testing & Inspections filed with 09-108304 Bldg M unit 32	2009
New	Building AA lot 97	2009
New	Building AA lot 98	2009
New	Bldg Z Unit 2 lot 100 Special inspections report for party walls is filmed with permit 09-100978	2009
New	Bldg Z Unit 3 lot 101 Special inspections report for party walls is filmed with permit 09-100978	2009
New	Bldg Z Unit 102, Special inspections report for party walls is filmed with permit 09-100978	2009
New	Bldg D Unit 3 lot 104	2009
New	Bldg D Unit 2 lot 105	2009
New	Bldg D Unit 1 lot 106	2009
New	Building Y unit 6 SPECIAL INSPECTION FILED W/09-107781	2009
New	Building Y unit 7 SPECIAL INSPECTION FILED W/09-107781	2009
New	Bldg Y unit 8 SPECIAL INSPECTION FILED W THIS PERMIT FOR 09-107881, 09-107779, 09-107778	2009
New	Bldg W, Unit 4, Lot 14	2009
New	Bldg W, Unit 4, Lot 15	2009
New	Bldg W Unit 4. Lot 16	2009
New	Bldg K unit 66 Special Consturction Testing & Inspections filed with permit 09-107782	2009
New	Bldg K unit 67 Special Consturction Testing & Inspections filed with permit 09-107782	2009
New	Bldg K unit 68 Special Consturction Testing & Inspections filed with permit 09-107782	2009
New	Building G lot 70 Special Inspection for party walls filed with Lot 72	2009
New	Building G lot 71	2009
New	Building G Lot 72 Special Inspection for party walls filed with Lot 72	2009
New	building H unit 74 Special inspections report for party walls is filmed with this permit 09-103430	2009
New	Building H Unit 75 Special inspections report for party walls is filmed with permit 09-100978	2009
New	Building H unit 76 Special inspections report for party walls is filmed with permit 09-100978	2009
New	Two-story residence with attached garage	2009
New	Issued - credit card failed to accept charges - applicant was to return same day, but he hasn t 11	2009
New	Issued - credit card failed to accept charges - applicant was to return same day, but he hasn t 11	2009
New	2-story w/garage	2009
New	New home, two-story w/ attached 2 car garage	2009
New	Special inspection for Construction Testing & Inspections filed with this permit Bldg M unit 29	2009
New	Bldg W, Unit 4, Lot 13	2009
New	Bldg Y unit 5 SPECIAL INSPECTION FILED W/09-107781	2009
New	Bldg Z Unit 1 lot 99 Special inspections report for party walls is filmed with this permit	2009
New	Building AA lot 96	2009
New	Bldg K unit 65 Special Consturction Testing & Inspections filed with this permit	2009
New	Building G lot 69 Special Inspection for party walls filed with Lot 72	2009
New	Building H unit 73 Special inspections report for party walls is filmed with permit 09-103430	2009
New	Bldg D Unit 4 lot 103	2009
New	Approved basic 09-105626 BP 2006 IRC Plan# 2102G 2-story sfr w/attached gar	2009
New	Approved basic 09-105626 BP 2006 IRC Plan# 2102G 2-story sfr w/attached gar	2009
New	Approved basic 09-105626 BP 2006 IRC Plan# 2102G 2-story sfr w/attached gar	2009
New	Approved basic 09-106717 BP 2006 IRC Plan# 1507 2-story sfr w/attached gara	2009
New	Approved basic 09-105626 BP 2006 IRC Plan# 2102G 2-story sfr w/attached gar	2009
New	Approved Basic 08-109932 BP 2006 IRC Plan: Westport Two story SFR with unfinished ba	2009
New	Approved Basic 08-108824-BP Plan No. Brighton (2) 2006 IRC 2 Story SFR w/ attached	2009
New	Approved Basic 08-109208-BP Plan No. Summerlin C (2) 2006 IRC 2 story SFR w/ attachec	2009
New	Approved Basic 09-100290-BP 2006 IRC Plan No. 2058 Rambler w/ 3-car garae	2009

Accessory Dwelling Units

Index # - File Name: 1.0022 - Single Family Dwellings Data\_Snohomish County.pdf

New	Approved Basic 08-109208-BP	Plan No. Summerlin C (2)	2006 IRC	2 story SFR w/ attached	2009
New	1-story single family residence with attached 2-car garage.				2009
New	Approved Basic 08-109207-BP	Plan No. Hampton (2)	2006 IRC	2 story SFR w/attached ga	2009
New	Approved Basic 08-105019-BP	Plan No. Glenbrook 2	2006 IRC	2 story SFR w/ attached garage	2009
New	Approved Basic 08-108823-BP	Plan No. Summerlin (2)	2006 IRC	2 story SFR w/ attached	2009
New	Approved Basic 08-105019-BP	Plan No. Glenbrook 2	2006 IRC	2 story SFR w/ attached garage	2009
New	Approved Basic 08-108823-BP	Plan No. Summerlin (2)	2006 IRC	2 story SFR w/ attached	2009
New	Approved basic 09-100390 BP	2006 IRC	Plan# Auburn	2-story sfr w/attached ga	2009
New	Approved Basic 08-108824-BP	Plan No. Brighton (2)	2006 IRC	2 Story SFR w/ attached	2009
New	Approved Basic 08-108823-BP	Plan No. Summerlin (2)	2006 IRC	2 story SFR w/ attached	2009
New	Approved Basic 08-108822-BP	Plan No. Elliston (2)	2006 IRC	2 story SFR w/attached garage	2009
New	Approved basic 09-100390 BP	2006 IRC	Plan# Auburn	2-story sfr w/attached ga	2009
New	Approved Basic 08-108823-BP	Plan No. Summerlin (2)	2006 IRC	2 story SFR w/ attached	2009
New	Approved Basic 08-108824-BP	Plan No. Brighton (2)	2006 IRC	2 Story SFR w/ attached	2009
New	Approved Basic 08-105018-BP	Plan No. Edgewood 2	2006 IRC	2 story SFR w/attached ga	2009
New	Approved Basic 08-108823-BP	Plan No. Summerlin (2)	2006 IRC	2 story SFR w/ attached	2009
New	Approved Basic 08-108824-BP	Plan No. Brighton (2)	2006 IRC	2 Story SFR w/ attached	2009
New	Approved basic 09-108477 BP	2006 IRC	Plan#2006-40-8	2-story sfr w/attached g	2009
New	Approved basic 09-108479 BP	2006 IRC	Plan # 2569-40-8	2-story sfr w/attach	2009
New	Approved basic 09-108478 BP	2006 IRC	Plan#2180-37-8	2-story sfr w/attache	2009
New	2 story sfr w/attached garage				2009
New	2 story daylight NO garage				2009
New	Approved Basic 09-100026-BP	Plan No. 1529	2006 IRC	2 story SFR w/ attached garage	2009
New	Approved Basic 09-101612 BP	2006 IRC	Plan# Mayfield B	2-story sfr w/attached	2009
New	Approved basic 09-104639 BP	2006 IRC	Plan# Kitsap A	2-story sfr w/attached ga	2009
New	Approved basic 09-104646 BP	2006 IRC	Plan# Dayton A	2-story sfr w/attached ga	2009
New	Approved basic 09-104652 BP	2006 IRC	Plan# Newman B	2-story srf w/attache	2009
New	Approved basic 09-103521 BP	2006 IRC	Plan# Skagit A	2-story sfr w/attached gar	2009
New	New 2 story home with attached garage extended until 7/8/11 to obtain final inspection dm 7/				2009
New	SFR in Flood Hazard Zone				2009
New	Approved basic 10-103609 BP	2009 IRC	Plan# 1987 SW	2-story sfr w/attached garag	2010
New	Approved basic 10-103608 BP	2009 IRC	Plan# 1670 SW	2-story sfr w/attached garage	2010
New	2-story sfr w/attached garage				2010
New	2- story sfr w/attached garage				2010
New	Approved Basic 09-101612 BP	2006 IRC	Plan# Mayfield B	2-story sfr w/attached	2010
New	Approved basic 10-101257 BP	2006 IRC	Plan# Bryant - B	2- story sfr w/attache	2010
New	Approved basic 09-104655 BP	2006 IRC	Plan# kitsap B	2-story sfr w/attached gara	2010
New	Approved basic 10-101257 BP	2006 IRC	Plan# Bryant - B	2- story sfr w/attache	2010
New	Two-story SFR - 2006 IRC				2010
New	Approved basic 09-102932 BP	2006 IRC	Plan# 3806 A/B	2-story sfr w/attached gar	2010
New	Approved basic 10-100669 BP	2006 IRC	Plan# 3805 AB New	2-story sfr w/attach	2010
New	Approved Basic 08-111194-BP	Plan No. 3803-B	2006 IRC	2 story SFR w/ attached g	2010
New	Approved Basic 08-111195-BP	Plan No. 3804-AB	2006 IRC	2 story SFR w/ attached g	2010
New	Approved basic 09-104027 BP	2006 IRC	Plan# 3820 B	2-story sfr w/attached garag	2010
New	Approved Basic 08-109065-BP	Plan No. 3822-B	2006 IRC	2 story SFR w/ attached garage	2010
New	Approved Basic 08-111195-BP	Plan No. 3804-AB	2006 IRC	2 story SFR w/ attached g	2010
New	Approved Basic 08-111195-BP	Plan No. 3804-AB	2006 IRC	2 story SFR w/ attached g	2010

Accessory Dwelling Units

Index # - File Name: 1.0022 - Single Family Dwellings Data\_Snohomish County.pdf

New	Approved Basic 08-109067-BP	Plan No. 3823-B	2006 IRC	2 story SFR w/ attached garage	2010
New	Approved Basic 08-109068-BP	Plan No. 3824-A	2006 IRC	2 story SFR w/ attached garage	2010
New	Approved Basic 08-109062-BP	Plan No 3821-A	2006 IRC	2 story SFR w/ attached garage	2010
New	Approved Basic 08-109066-BP	Plan No. 3823-A	2006 IRC	2nd story SFR w/ attached garage	2010
New	Approved basic 09-104026 BP	2006 IRC	Plan# 3820 A	2-story sfr w/attached garage	2010
New	Approved Basic 08-109069-BP	Plan No. 3824-B	2006 IRC	2 story SFR w/ attached garage	2010
New	Approved Basic 08-109063-BP	Plan No. 3821-B	2006 IRC	2 story SFR w/ attached garage	2010
New	Approved Basic 08-109067-BP	Plan No. 3823-B	2006 IRC	2 story SFR w/ attached garage	2010
New	Approved Basic 08-109064-BP	Plan No. 3822-A	2006 IRC	2 story SFR w/ attached garage	2010
New	Approved basic 09-104027 BP	2006 IRC	Plan# 3820 B	2-story sfr w/attached garage	2010
New	Approved Basic 08-109069-BP	Plan No. 3824-B	2006 IRC	2 story SFR w/ attached garage	2010
New	Approved Basic 08-111195-BP	Plan No. 3804-AB	2006 IRC	2 story SFR w/ attached garage	2010
New	Approved basic 09-102932 BP	2006 IRC	Plan# 3806 A/B	2-story sfr w/attached garage	2010
New	Approved basic 10-100669 BP	2006 IRC	Plan# 3805 AB New	2-story sfr w/attached garage	2010
New	Approved Basic 08-111193-BP	Plan No. 3803-A	2006 IRC	2 story SFR w/ attached garage	2010
New	Rambler style sfr w/attached garage				2010
New	Two-story SFR with attached garage - 2009 IRC				2010
New	Approved basic 10-102225 BP	2006 IRC	Plan 2258	2-story sfr w/attached garage	2010
New	Approved basic 10-102228 BP	2006 IRC	Plan# 2178	2-story sfr w/attached garage	2010
New	Approved basic 10-107036 BP	2009 IRC	Plan # 3726-B	2-story sfr w/attached garage	2010
New	Approved basic 10-106093 BP	2009 IRC	Plan# 3723-AB	2-story sfr w/attached garage	2010
New	Approved basic 10-106094 BP	2009 IRC	Plan# 3724-A	2-story sfr w/attached garage	2010
New	Approved basic 10-107750 BP	2009 IRC	Plan# 3706-B	2-story sfr w/attached garage	2010
New	Approved basic 10-108094 BP	2009 IRC	Plan# 3705-AB	2-story sfr w/attached garage	2010
New	Approved basic 10-108093 BP	2009 IRC	Plan# 3704-AB	2-story sfr w/attached garage	2010
New	SFR Rambler style, 3 bedroom, 2 bath home with attached two car garage				2010
New	SFR - rambler with attached 2-car garage				2010
New	SFR, two story style with attached 3-car garage				2010
New	Two-story SFR with attached garage - 2009 IRC				2010
New	SFR, two story style with attached garage				2010
New	2-Story single family residence with attached garage.				2010
New	Two-story SFR with attached garage - 2009 IRC				2010
New	SFR, 2-story style home with unfinished basement and 3-car garage with covered porch				2010
New	Approved Basic 08-105360-BP	Plan No. 2357-02Av2	2006 IRC	2 story SFR w/ attached garage	2010
New	Approved Basic 08-106996-BP	Plan No. 2368-03AB	2006 IRC	3 story SFR w/ 1st story garage	2010
New	Approved basic 10-108366 BP	2009 IRC	Plan 1950-02AB	3 story sfr w/tuck under garage	2010
New	Approved basic 09-100630 BP	2006 IRC	Plan#2268-02 AB	2-story sfr w/attached garage	2010
New	Two - story SFR with attached garage - 2006 IRC				2010
New	Extended 45 days to allow for final inspection	1/25/12	dm 12/23/11	Proposed two-story single family residence	2010
New	Approved basic 10-105930 BP	2009 IRC	Plan# Shaw- B	2-story sfr w/attached garage	2010
New	Approved basic 10-105929 BP	2009 IRC	Plan# Madison B	2-story sfr w/attached garage	2010
New	Approved basic 10-105529 BP	2009 IRC	Plan# Baker A	2-story sfr w/attached garage	2010
New	Approved basic 10-105540 BP	2009 IRC	Plan# Cascade B	2-story sfr w/attached garage	2010
New	Approved basic 10-105931 BP	2009 IRC	Plan# Shasta II-A	2-story sfr w/attached garage	2010
New	Approved basic 10-100319 BP	2006 IRC	Plan# Labrador	2-story sfr w/attached garage	2010
New	Approved basic 10-106988 BP	2009 IRC	Plan# 2448	2-story sfr w/attached garage	2010
New	Approved basic 10-100329 BP	2006 IRC	Plan# 2448	2-story sfr w/attached garage	2010

Accessory Dwelling Units

Index # - File Name: 1.0022 - Single Family Dwellings Data\_Snohomish County.pdf

New	Approved basic 10-100329 BP	2006 IRC	Plan# 2448	2-story sfr w/attached garage	2010
New	Approved basic 09-106885 BP	2006 IRC	Plan# 2195	Rambler daylight w/ga	2010
New	Approved basic 09-106885 BP	2006 IRC	Plan# 2195	Rambler daylight w/ga	2010
New	Approved basic 10-106988 BP	2009 IRC	Plan# 2448	2-story sfr w/attached garage	2010
New	Approved basic 09-106885 BP	2006 IRC	Plan# 2195	Rambler daylight w/ga	2010
New	Approved Basic 09-101612 BP	2006 IRC	Plan# Mayfield B	2-story sfr w/attached	2010
New	Approved Basic 09-100027-BP	Plan No. 1239	2006 IRC	2 story SFR w/ attached garage	2010
New	Approved basic 09-108756 BP	2006 IRC	Plan# 1735	2-story sfr w/attached garage	2010
New	Approved basic 09-101299 BP	2006 IRC	Plan# 1372	Rambler style sfr w/attache	2010
New	2-story sfr w/attached garage				2010
New	2-story sfr w/attached garage				2010
New	2-story sfr w/attached garage				2010
New	2-story sfr w/attached garage				2010
New	Approved basic 09-108242 BP	2006 IRC	Plan# Donovan Ramber 3 car only	Ramber	2010
New	Approved: Basic # 07-109717 BP	2006 IRC	Plan # 06.12.113	Split level SFR with attached Gar	2010
New	Mid entry sfr w/attached garage				2010
New	Mid enty sfr w/attached garage				2010
New	Approved basic 09-108477 BP	2006 IRC	Plan#2006-40-8	2-story sfr w/attached g	2010
New	Approved basic 10-100834 BP	2006 IRC	Plan# Donovan Rambler 2 car only	2-	2010
New	2-story sfr w/attached garage				2010
New	Approved basic 09-108477 BP	2006 IRC	Plan#2006-40-8	2-story sfr w/attached g	2010
New	Rambler style home with basement & attached 3 car garage				2010
New	Approved basic 09-106885 BP	2006 IRC	Plan# 2195	Rambler daylight w/ga	2010
New	Approved basic 10-100329 BP	2006 IRC	Plan# 2448	2-story sfr w/attached garage	2010
New	2-Story single family residence w/ attached 2 car garage				2010
New	Approved basic 10-106992 BP	2009 IRC	Plan# 2195-0	2-story sfr w/attached gar	2010
New	Approved basic 09-102243 BP	2006 IRC	Plan# Jameson A	2-story sfr w/attached g	2010
New	Approved basic 09-104655 BP	2006 IRC	Plan# kitsap B	2-story sfr w/attached gara	2010
New	Approved Basic #07-113360 BP	2006 IRC	Plan: Mansfield B	Two Story SFR w/attached gara	2010
New	Approved basic 09-101611 BP	2006 IRC	Plan# Maybiel A	2-story sfr w/attached j	2010
New	Approved Basic #07-113350 BP	2006 IRC	Plan: Hazelwood B	Two Story SFR w/attached gar	2010
New	Approved basic 09-104655 BP	2006 IRC	Plan# kitsap B	2-story sfr w/attached gara	2010
New	Approved basic 09-104647 BP	2006 IRC	Plan# Dayton B	2-story sfr w/attached j	2010
New	Approved basic 09-100642 BP	2006 IRC	Plan# Granite A	2-story sfr w/attached gar	2010
New	Approved basic 09-104646 BP	2006 IRC	Plan# Dayton A	2-story sfr w/attached ga	2010
New	Approved basic 09-108140 BP	2006 IRC	Plan# Omak-A	2-story sfr w/attached gara	2010
New	Approved basic 10-101193 BP	2006 IRC	Plan# Selkirk - B	2-story sfr w/attached ga	2010
New	Approved basic 10-101178 BP	2006 IRC	Plan# Stevens B	2-story sfr w/attached ga	2010
New	Approved basic 10-100186 BP	2006 IRC	Plan# Whitman A	2-story sfr w/attached gara	2010
New	Approved basic 09-108383 BP	2006 IRC	Plan# Campbell II B	2-story sfr w/attached g	2010
New	Approved basic 09-108140 BP	2006 IRC	Plan# Omak-A	2-story sfr w/attached gara	2010
New	Approved basic 10-100186 BP	2006 IRC	Plan# Whitman A	2-story sfr w/attached gara	2010
New	Approved basic 10-101177 BP	2006 IRC	Plan# Stevens - A	2-story sfr w/attached g	2010
New	2-story sfr w/attached garage				2010
New	Approved basic 10-100319 BP	2006 IRC	Plan# Labrador	2-story sfr w/attached g	2010
New	Approved basic 10-100319 BP	2006 IRC	Plan# Labrador	2-story sfr w/attached g	2010

Accessory Dwelling Units

Index # - File Name: 1.0022 - Single Family Dwellings Data\_Snohomish County.pdf

New	Install new manufactured home, 2010 Fleetwood				2010
New	SFR, rambler style with attached garage				2010
New	1685 sf SFR with 1472 sf finished daylight basement and attached garage - 2006 IRC				2010
New	Approved basic 09-104039 BP	2006 IRC	Plan# 2370 SW FLR	2-story sfr w/attached g	2010
New	Approved basic 09-104038 BP	2006 IRC	Plan# 2217 SW FLR	2-story sfr w/attached g	2010
New	Approved basic 10-103613 BP	2009 IRC	Plan# 2493 SW	2-story sfr w/attached garage	2010
New	Approved basic 10-103610 BP	2009 IRC	Plan# 2023 SW	2-story sfr w/attached garage	2010
New	Approved basic 09-104039 BP	2006 IRC	Plan# 2370 SW FLR	2-story sfr w/attached g	2010
New	Approved basic 09-104040 BP	2006 IRC	Plan# 2493 SW FLR	2-story sfr w/attache	2010
New	Approved basic 09-104036 BP	2006 IRC	Plan# 1987 SW FLR	2-story sfr w/attached	2010
New	Approved basic 09-104037 BP	2006 IRC	Plan# 2023 SW FLR	2-story sfr w/attached g	2010
New	Approved basic 09-104040 BP	2006 IRC	Plan# 2493 SW FLR	2-story sfr w/attache	2010
New	Approved basic 09-104039 BP	2006 IRC	Plan# 2370 SW FLR	2-story sfr w/attached g	2010
New	Approved basic 09-104038 BP	2006 IRC	Plan# 2217 SW FLR	2-story sfr w/attached g	2010
New	Approved basic 09-104040 BP	2006 IRC	Plan# 2493 SW FLR	2-story sfr w/attache	2010
New	Approved basic 09-104037 BP	2006 IRC	Plan# 2023 SW FLR	2-story sfr w/attached g	2010
New	Approved basic 09-104039 BP	2006 IRC	Plan# 2370 SW FLR	2-story sfr w/attached g	2010
New	Approved basic 09-104039 BP	2006 IRC	Plan# 2370 SW FLR	2-story sfr w/attached g	2010
New	Approved basic 09-104040 BP	2006 IRC	Plan# 2493 SW FLR	2-story sfr w/attache	2010
New	Approved basic 09-104037 BP	2006 IRC	Plan# 2023 SW FLR	2-story sfr w/attached g	2010
New	Approved basic 09-104039 BP	2006 IRC	Plan# 2370 SW FLR	2-story sfr w/attached g	2010
New	Approved basic 09-104038 BP	2006 IRC	Plan# 2217 SW FLR	2-story sfr w/attached g	2010
New	Approved basic 09-104036 BP	2006 IRC	Plan# 1987 SW FLR	2-story sfr w/attached	2010
New	Approved basic 09-104039 BP	2006 IRC	Plan# 2370 SW FLR	2-story sfr w/attached g	2010
New	Approved basic 09-104040 BP	2006 IRC	Plan# 2493 SW FLR	2-story sfr w/attache	2010
New	Approved basic 09-104040 BP	2006 IRC	Plan# 2493 SW FLR	2-story sfr w/attache	2010
New	Approved basic 09-104039 BP	2006 IRC	Plan# 2370 SW FLR	2-story sfr w/attached g	2010
New	requested 30 day extension 3/27/12 dm	Approved basic 10-105846 BP	2009 IRC	Pla	2010
New	Approved basic 10-105569 BP	2009 IRC	Plan # 1701	2-story duplex w/attache	2010
New	Approved basic 10-105569 BP	2009 IRC	Plan # 1701	2-story duplex w/attache	2010
New	Approved basic 10-105568 BP	2009 IRC	Plan # 2070	2-story sfr w/attached gara	2010
New	Approved basic 10-105566 BP	2009 IRC	Plan # 2168	2-story duplex w/attache	2010
New	Approved basic 10-105566 BP	2009 IRC	Plan # 2168	2-story sfr w/attached ga	2010
New	2-story sfr w/attached garage				2010
New	14 x 64				2010
New	Approved basic 10-105911 BP	2009 IRC	Plan#2140-02A-09	2-story sfr w/attached g	2010
New	Approved basic 10-106169 BP	2009 IRC	Plan#2012-02AB-09	2-story sfr w/attache	2010
New	Approved basic 10-105911 BP	2009 IRC	Plan#2140-02A-09	2-story sfr w/attached g	2010
New	Approved basic 10-106169 BP	2009 IRC	Plan#2012-02AB-09	2-story sfr w/attache	2010
New	Two-story SFR with attached garage - 2006 IRC				2010
New	Approved Basic 08-108824-BP	Plan No. Brighton (2)	2006 IRC	2 Story SFR w/ attached	2010
New	Approved basic 09-100390 BP	2006 IRC	Plan# Auburn	2-story sfr w/attached ga	2010
New	SFR, Rambler with attached two car garage and covered porch				2010
New	Approved Basic 08-109207-BP	Plan No. Hampton (2)	2006 IRC	2 story SFR w/attached ga	2010
New	2-story sfr w/attached garage				2010
New	Approved basic 09-106192 BP	2006 IRC	Plan# 2286	Rambler style sfr w/attache	2010
New	Approved basic 09-106192 BP	2006 IRC	Plan# 2286	Rambler style sfr w/attache	2010

Accessory Dwelling Units

Index # - File Name: 1.0022 - Single Family Dwellings Data\_Snohomish County.pdf

New	Approved basic 10-106847 BP	2009 IRC	Plan# 1883 40#	2-story sfr w/attached	2010
New	Approved basic 10-106847 BP	2009 IRC	Plan# 1883 40#	2-story sfr w/attached	2010
New	Approved basic 10-106427 BP	2009 IRC	Plan# 1529 40#	2-story sfr w/attached gara	2010
New	Approved 10-106427 BP	2009 IRC	Plan# 1529 40#	2-story sfr w/attached garage	2010
New	Approved basic 09-108477 BP	2006 IRC	Plan#2006-40-8	2-story sfr w/attached g	2010
New	Approved basic 09-108478 BP	2006 IRC	Plan#2180-37-8	2-story sfr w/attachec	2010
New	Approved basic 09-108477 BP	2006 IRC	Plan#2006-40-8	2-story sfr w/attached g	2010
New	Approved basic 09-108479 BP	2006 IRC	Plan # 2569-40-8	2-story sfr w/attach	2010
New	Approved basic 09-108479 BP	2006 IRC	Plan # 2569-40-8	2-story sfr w/attach	2010
New	Approved basic 09-108477 BP	2006 IRC	Plan#2006-40-8	2-story sfr w/attached g	2010
New	Approved basic 09-108478 BP	2006 IRC	Plan#2180-37-8	2-story sfr w/attachec	2010
New	Approved basic 09-108477 BP	2006 IRC	Plan#2006-40-8	2-story sfr w/attached g	2010
New	Approved basic 10-103193 BP	2009 IRC	Plan# Auburn	2-story sfr w/attached ga	2010
New	Approved Basic 08-108824-BP	Plan No. Brighton (2)	2006 IRC	2 Story SFR w/ attached	2010
New	Approved basic 10-103187 BP	2009 IRC	Plan# Summerlin	2-story sfr w/attached	2010
New	Approved basic 10-103190 BP	2009IRC	Plan# Brighton	2-story sfr w/attachec	2010
New	Approved basic 10-103190 BP	2009IRC	Plan# Brighton	2-story sfr w/attachec	2010
New	Approved Basic 08-109932 BP	2006 IRC	Plan: Westport	Two story SFR with unfinished ba	2010
New	2 story sfr with unfinished basement and attached garage				2010
New	Two-story residence with unfinished basement and attached garage;				2010
New	1207 sq ft Rambler with attached Garage				2010
New	1283 sq ft Rambler with attached Garage				2010
New	Approved basic 10-105991 BP	2009 IRC	Plan# 1756 split	2-story sfr w/attached gara	2010
New	Approved basic 09-108242 BP	2006 IRC	Plan# Donovan Ramber	3 car only Ramber s	2010
New	Building L unit 77				2010
New	Two-story SFR with attached garage - 2003 IRC				2010
New	Building BB unit 93				2010
New	Bldg N unit 49				2010
New	Daylight rambler w/attachced garage				2010
New	Two-story residence with attached garage				2010
New	Building L unit 78				2010
New	Building L unit 79				2010
New	Building L unit 80				2010
New	Bldg N unit 50				2010
New	Bldg N unit 51				2010
New	Bldg N unit 52				2010
New	Building BB unit 94				2010
New	Building BB unit 95				2010
New	Approved basic 09-108429 BP	2006 IRC	Plan# M2490-58 master front	2-stoy sfr w/attach	2010
New	Approved basic 10-101986 BP	2006 IRC	Plan# Greenleaf #18	2-story sfr w/atta	2010
New	Approved basic 09-107813 BP	2006 IRC	Plan# 2980 Greenleaf	2-story sfr w/atta	2010
New	Approved basic 10-101796 BP	2006 IRC	Plan # Greenleaf #5	2-story sfr w/attached g	2010
New	Approved basic 10-101986 BP	2006 IRC	Plan# Greenleaf #18	2-story sfr w/atta	2010
New	Approved basic 10-102157 BP	2006 IRC	Plan#3570A3F-0	2-story sfr w/attached g	2010
New	2-story sfr w/attached garage				2010
New	2-story sfr w/attached garage				2010
New	Approved basic 10-102157 BP	2006 IRC	Plan#3570A3F-0	2-story sfr w/attached	2010

Accessory Dwelling Units

Index # - File Name: 1.0022 - Single Family Dwellings Data\_Snohomish County.pdf

New	2-story sfr w/attached garage				2010
New	2 - story sfr w/attached garage				2010
New	Approved basic 09-108433 BP	2006 IRC	Plan# 2690 Greenleaf	2-story sfr w/attached	2010
New	Approved basic 09-107813 BP	2006 IRC	Plan# 2980 Greenleaf	2-story sfr w/atta	2010
New	Approved basic 10-101796 BP	2006 IRC	Plan # Greenleaf #5	2-story sfr w/attached }	2010
New	Approved basic 09-108431 BP	2006 IRC	Plan# 2490-1Master R	2-story sfr w/attache	2010
New	2 story SFR *permit issued under 270521-003-021-00*				2010
New	Approved basic 10-105528 BP	2009 IRC	Plan # Cypress B	2-story sfr w/attached g	2010
New	Approved basic 10-105529 BP	2009 IRC	Plan# Baker A	2-story sfr w/attached gar	2010
New	Approved basic 10-105537 BP	2009 IRC	Plan # Blakely B	2-story sfr w/attached ga	2010
New	Approved basic 10-105538 BP	2009 IRC	Plan# Chelan II A	2-story sfr w/attached	2010
New	Approved basic 10-105540 BP	2009 IRC	Plan# Cascade B	2-story sfr w/attached	2010
New	2-story sfr w/attached garage				2010
New	2-story sfr w/attached garage				2010
New	Approved basic 09-108155 BP	2006 IRC	Plan# 4141	2-story sfr w/attached gara	2010
New	SFR - 2 story with basement & 3 car garage with open deck				2010
New	Two story home with attached 2-car garage				2010
New	Two story home with attached 2-car garage; NSF Check - accept only cash, cashier s check or cre				2010
New	2-story Single Family Residence with heated attic storage Design By Sandra J. Alder, R.A. 5720 9				2010
New	Duplex, two story style with attached garages				2010
New	Two-story SFR with attached garage - 2009 IRC				2010
New	Two-story SFR with attached garage - 2009 IRC				2010
New	Approved basic 09-106925 BP	2006 IRC	Plan# 3431-3	2-story sfr w/attached gara	2010
New	Approved basic 10-101972 BP	2006 IRC	plan# 2761-3	2-story sfr w/attached garage	2010
New	2 story SFR				2010
New	Two-story SFR with attached garage - 2009 IRC				2010
New	Approved basic 10-100737 BP	2006 IRC	Plan# 3165	2-story sfr w/attached garage	2010
New	2-story sfr w/attached garage				2010
New	2-story sfr w/attached garage				2010
New	Approved basic 10-100314 BP	2006 IRC	Plan# 2464	2-story sfr w/attached garage	2010
New	Approved basic 10-105501 BP	2009 IRC	Plan# 2186	Rambler w/attached gara	2010
New	2-story sfr w/attached garage (1). Engineer Andrew M. Gahn, P.E. 44226				2010
New	Approved basic 10-100314 BP	2006 IRC	Plan# 2464	2-story sfr w/attached garage	2010
New	Approved basic 10-105501 BP	2009 IRC	Plan# 2186	Rambler w/attached gar	2010
New	Approved basic 10-100319 BP	2006 IRC	Plan# Labrador	2-story sfr w/attached g	2010
New	Three-story residence with garage on main floor				2010
New	3 story SFR				2010
New	Approved basic 10-100313 BP	2006 IRC	Plan# 2864	2-story sfr w/attached gara	2010
New	Rambler style sfr w/attached garage				2010
New	1694 sf SFR with 405 sf 2nd floor bonus room ad 651sf attached garage - 2006 IRC				2010
New	Approved basic 10-105943 BP	2009 IRC	Plan# 3174	2-story sfr w/attached garage	2010
New	Approved basic 09-103594 BP	2006 IRC	Plan# Jupiter	Rambler w/attached gara	2010
New	Approved Basic 09-100026-BP	Plan No. 1529	2006 IRC	2 story SFR w/ attached garage	2010
New	Two-story SFR with attached garage - 2009 IRC Plan: 1943 mitigation defferred AF#20110				2010
New	Two-story SFR with attached garage - 2009 IRC Plan: 1943 mitigation defferred AF#201101				2010
New	Two-story SFR with attached garage - 2009 IRC Plan: 1963 mitigation defferred AF#201101				2010
New	Two-story SFR with attached garage - 2009 IRC Plan: 1943 mitigation defferred AF#2011010				2010

Accessory Dwelling Units

Index # - File Name: 1.0022 - Single Family Dwellings Data\_Snohomish County.pdf

New	Two-story SFR with attached garage - 2009 IRC	Plan: 1963 mitigation defferred AF#2011	2010
New	Two-story SFR with attached garage - 2009 IRC	Plan: 1963 mitigation defferred AF#2011010	2010
New	Two-story SFR with attached garage - 2009 IRC	Plan: 1943 mitigation defferred AF#2011010:	2010
New	One-story SFR with attached garage		2010
New	Approved basic 09-108382 BP	2006 IRC Plan# Campbell II A	2-story sfr w/attached 2010
New	Approved Basic #07-113350 BP	2006 IRC Plan: Hazelwood B	Two Story SFR w/attached gar 2010
New	Approved basic 09-108382 BP	2006 IRC Plan# Campbell II A	2-story sfr w/attached 2010
New	Approved basic 09-101299 BP	2006 IRC Plan# 1372	Rambler style sfr w/attache 2010
New	Approved basic 09-105610 BP	2006 IRC Plan # 2150	Rambler style sfr w/attached 2010
New	Approved basic 09-104584 BP	2006 IRC Plan# 2208	2-story sfr w/attached garag 2010
New	Approved basic 09-104585 BP	2006 IRC Plan#2595	2-story sfr w/attached garage 2010
New	Approved basic 09-105610 BP	2006 IRC Plan # 2150	Rambler style sfr w/attached 2010
New	Approved basic 09-104587 BP	2006 IRC Plan# 2823	2-story sfr w/attached garage 2010
New	Approved basic 09-104587 BP	2006 IRC Plan# 2823	2-story sfr w/attached garage 2010
New	Approved basic 09-105610 BP	2006 IRC Plan # 2150	Rambler style sfr w/attached 2010
New	Approved basic 09-104587 BP	2006 IRC Plan# 2823	2-story sfr w/attached garage 2010
New	Approved basic 07-110397 BP	2006 IRC Plan# 2098	Rambler w/daylight basement attch 2010
New	Approved basic 09-104587 BP	2006 IRC Plan# 2823	2-story sfr w/attached garage 2010
New	Approved basic 07-110397 BP	2006 IRC Plan# 2098	Rambler w/daylight basement attch 2010
New	Approved basic 07-110397 BP	2006 IRC Plan# 2098	Rambler w/daylight basement attch 2010
New	Approved basic 09-104587 BP	2006 IRC Plan# 2823	2-story sfr w/attached garage 2010
New	Rambler with attached garage		2010
New	Two-story SFR with attached garage - 2009 IRC	Plan 1963 mitigation defferred AF#201101030:	2010
New	SFR, two story style with attached 3-car garage		2010
New	Approved basic 09-100225 BP	2006 IRC Plan# 2131	Rambler style sfr w/attached gara 2010
New	2 story sfr w/attached garage		2010
New	Approved Basic 08-107319-BP	Plan No 2664 2006 IRC	2 story SFR w/attached garage 2010
New	Approved Basic 08-107316-BP	Plan No. 2426 2006 IRC	two story SFR w/ attached garage 2010
New	Approved basic 09-100225 BP	2006 IRC Plan# 2131	Rambler style sfr w/attached gara 2010
New	Rambler style sfr w/attached garage		2010
New	Approved basic 10-100224 BP	2006 IRC Plan# 1960 w/bonus	2-story sfr w/attache 2010
New	Approved basic 10-100224 BP	2006 IRC Plan# 1960 w/bonus	2-story sfr w/attache 2010
New	Approved basic 09-100243 BP		2-story sfr w/attached garage 3 car option 2010
New	Two-story residence with attached garage		2010
New	Two-story SFR with attached garage - 2006 IRC		2010
New	Split level residence with attached garage		2010
New	Split-level residence with attached garage		2010
New	Approved Basic 07-112450 BP	2006 IRC	Plan: 1988 Plan ( 2010
New	Approved basic 10-108094 BP	2009 IRC Plan# 3705-AB	2-story sfr w/attached ga 2010
New	Approved basic 10-107749 BP	2009 IRC Plan# 3706-A	2-story sfr w/attached gara 2010
New	Approved basic 10-108093 BP	2009 IRC Plan# 3704-AB	2-story sfr w/attached 2010
New	Approved basic 09-104040 BP	2006 IRC Plan# 2493 SW FLR	2-story sfr w/attache 2010
New	Approved basic 09-104037 BP	2006 IRC Plan# 2023 SW FLR	2-story sfr w/attached 2010
New	Approved basic 09-104039 BP	2006 IRC Plan# 2370 SW FLR	2-story sfr w/attached g 2010
New	Approved basic 09-104040 BP	2006 IRC Plan# 2493 SW FLR	2-story sfr w/attache 2010
New	Approved basic 09-104039 BP	2006 IRC Plan# 2370 SW FLR	2-story sfr w/attached g 2010
New	Approved basic 10-108093 BP	2009 IRC Plan# 3704-AB	2-story sfr w/attached 2010



Accessory Dwelling Units

Index # - File Name: 1.0022 - Single Family Dwellings Data\_Snohomish County.pdf

New	Approved basic 10-100908 BP	2006 IRC	Plan# 2682-03AB	20story sfr w/attached	2010
New	Approved basic 10-100983 BP	2006 IRC	Plan# 2763-03AB	2-story sfr w/attached gar	2010
New	Approved basic 10-100900 BP	2006 IRC	Plan# 2500-03AB	2-story sfr w/attached g	2010
New	Approved basic 09-100630 BP	2006 IRC	Plan#2268-02 AB	2-story sfr w/attached gar	2010
New	Approved basic 10-100521 BP	2006 IRC	Plan# 2583-03AB	2-story sfr w/attached gar	2010
New	Approved basic 10-100522 BP	2006 IRC	Plan# 2749-43AB	2-story sfr w/attached ga	2010
New	Approved basic 10-100908 BP	2006 IRC	Plan# 2682-03AB	20story sfr w/attached g	2010
New	Approved basic 10-100522 BP	2006 IRC	Plan# 2749-43AB	2-story sfr w/attached g	2010
New	Approved basic 09-108853 BP	2006 IRC	Plan# 2950-03AB	2-story sfr w/attached gar	2010
New	Approved basic 10-100521 BP	2006 IRC	Plan# 2583-03AB	2-story sfr w/attached gar	2010
New	Approved basic 10-100905 BP	2006 IRC	Plan# 3343-03AB	2-story sfr w/attached ga	2010
New	Approved basic 10-100983 BP	2006 IRC	Plan# 2763-03AB	2-story sfr w/attached ga	2010
New	Approved basic 10-100903 BP	2006 IRC	Plan# 3310-03AB	2-story sfr w/attached gar	2010
New	2-story sfr w/attached garage				2010
New	2-story sfr w/attached garage				2010
New	2-story sfr w/attached garage				2010
New	2-story sfr w/attached garage				2010
New	2 story sfr /attached garage				2010
New	Two-story SFR with attached garage - 2006 IRC				2010
New	2-story sfr w/attached garage				2010
New	2-story sfr w/attached garage				2010
New	2 story sfr w/attached garage				2010
New	2-story sfr w/attached garage				2010
New	2-story sfr w/attached garage				2010
New	Approved basic 10-100983 BP	2006 IRC	Plan# 2763-03AB	2-story sfr w/attached gar	2010
New	Approved basic 10-100903 BP	2006 IRC	Plan# 3310-03AB	2-story sfr w/attached gar	2010
New	Approved basic 09-108853 BP	2006 IRC	Plan# 2950-03AB	2-story sfr w/attached gar	2010
New	Approved basic 10-100903 BP	2006 IRC	Plan# 3310-03AB	2-story sfr w/attached gar	2010
New	Approved Basic 07-112055-BP	2006 IRC	Plan # AG2100-02-B	2-Story SFR w/ ati	2010
New	Approved basic 09-108888 BP	2006 IRC	Plan# 1930-42AD	2-story sfr w/attached gara	2010
New	Approved Basic 08-105361-BP	Plan No 2245-02Av2	2006 IRC	2 story SFR w/attached garag	2010
New	Approved basic 09-100551 BP	2006 IRC	Plan# 1365-01AB	2-story sfr w/attached ga	2010
New	EXTENDED one year application extension granted. Do not void out until after JULY 26, 2011 pe				2010
New	Approved basic 09-108888 BP	2006 IRC	Plan# 1930-42AD	2-story sfr w/attached gara	2010
New	2 story sfr w/daylight basement w/attached garage				2010
New	Approved basic 09-109124 BP	2006 IRC	Plan#1221 C	2-story sfr w/attached ga	2010
New	Approved basic 09-109124 BP	2006 IRC	Plan#1221 C	2-story sfr w/attached g	2010
New	Approved basic 09-103608 BP	2006 IRC	Plan# 1529	2-story sfr w/attached gara	2010
New	Approved basic 09-103608 BP	2006 IRC	Plan# 1529	2-story sfr w/attached gara	2010
New	Approved basic 09-109124 BP	2006 IRC	Plan#1221 C	2-story sfr w/attached ga	2010
New	Approved basic 09-109124 BP	2006 IRC	Plan#1221 C	2-story sfr w/attached ga	2010
New	Approved basic 09-103608 BP	2006 IRC	Plan# 1529	2-story sfr w/attached gara	2010
New	Approved basic 09-103608 BP	2006 IRC	Plan# 1529	2-story sfr w/attached gara	2010
New	Approved basic 09-109124 BP	2006 IRC	Plan#1221 C	2-story sfr w/attached ga	2010
New	Approved basic 09-109124 BP	2006 IRC	Plan#1221 C	2-story sfr w/attached ga	2010
New	Approved basic 09-103608 BP	2006 IRC	Plan# 1529	2-story sfr w/attached gara	2010

Accessory Dwelling Units

Index # - File Name: 1.0022 - Single Family Dwellings Data\_Snohomish County.pdf

New	Approved	basic 09-103608 BP	2006 IRC	Plan# 1529	2-story sfr w/attached gara	2010
New	Approved	basic 09-109124 BP	2006 IRC	Plan#1221 C	2-story sfr w/attached ga	2010
New	Approved	basic 09-103608 BP	2006 IRC	Plan# 1529	2-story sfr w/attached gara	2010
New	Approved	basic 09-103608 BP	2006 IRC	Plan# 1529	2-story sfr w/attached gara	2010
New	Approved	basic 09-103608 BP	2006 IRC	Plan# 1529	2-story sfr w/attached gara	2010
New	Approved	basic 09-109124 BP	2006 IRC	Plan#1221 C	2-story sfr w/attached ga	2010
New	Approved	basic 09-103608 BP	2006 IRC	Plan# 1529	2-story sfr w/attached gara	2010
New	Approved	basic 09-103608 BP	2006 IRC	Plan# 1529	2-story sfr w/attached gara	2010
New	Approved	basic 09-109124 BP	2006 IRC	Plan#1221 C	2-story sfr w/attached g	2010
New		2-story sfr w/attached garage				2010
New	Approved	basic 10-106155 BP	2009 IRC	Plan# 1723 A	2-story sfr w/attached gara	2010
New	Approved	Basic 10- 102728 BP	Plan: 2064	2006 IRC	Two-story SFR with attached ;	2010
New	Approved	Basic 10-102725BP	2006 IRC	Plan: 1892M Elevations A&B	Two-story SFR wit	2010
New	Approved	basic 10-108071 BP	2009 IRC	Plan# 1472	Ramber style w/attached gara	2010
New	Approved	Basic 10-102908 BP	Two-story SFR with attached garage - 2006 IRC	Plan: 2208		2010
New	Approved	basic 10-106147 BP	2009 IRC	Plan# 1892 A	2-story sfr w/attached gara	2010
New	Approved	Basic 10-102727BP	2006 IRC	Plan: 1935-M Elev. A / B	Two story sfr with ati	2010
New	Approved	basic 10-101063 BP	2006 IRC	Plan# 2278	2-story sfr w/attached garage	2010
New	Approved	basic 09-108128 BP	2006 IRC	Plan#2211	2-story sfr w/attached gar	2010
New	Approved	basic 09-103296 BP	2006 IRC	Plan# 1996 A	2 - story sfr w/attached ga	2010
New	Approved	basic 10-101063 BP	2006 IRC	Plan# 2278	2-story sfr w/attached garage	2010
New	Approved	basic 07-110789 BP	2006 IRC	Plan# 2537	2-story sfr w/attached garage	2010
New	Approved	basic 09-108126 BP	2006 IRC	Plan# 2501 B	2-story sfr w/attached gar	2010
New	Approved	basic 09-108123 BP	2006 IRC	Plan# 2647 b	2-story sfr w/attached ga	2010
New	Approved	basic 09-103298 BP	2006 IRC	Plan# 2744	2-story sfr w/attached ;	2010
New		2-story sfr w/attached garage				2010
New		2-story sfr w/attached garage				2010
New		2-story sfr w/attached garage				2010
New		2-story sfr w/attached garage				2010
New		2-story sfr w/attached garage				2010
New	Approved	basic 09-102881 BP	2006 IRC	Plan# 628	2-story sfr w/attached garage	2010
New	Approved	basic 09-102881 BP	2006 IRC	Plan# 628	2-story sfr w/attached garage	2010
New	Approved	basic 09-102881 BP	2006 IRC	Plan# 628	2-story sfr w/attached garage	2010
New	Approved	basic 09-102881 BP	2006 IRC	Plan# 628	2-story sfr w/attached garage	2010
New	Approved	basic 09-102881 BP	2006 IRC	Plan# 628	2-story sfr w/attached garage	2010
New	Approved	basic 09-102881 BP	2006 IRC	Plan# 628	2-story sfr w/attached garage	2010
New	Approved	basic 09-102881 BP	2006 IRC	Plan# 628	2-story sfr w/attached garage	2010
New	Approved	basic 09-102879 BP	2006 IRC	Plan# 627	2-story sfr w/attached garage	2010
New	Approved	basic 09-102881 BP	2006 IRC	Plan# 628	2-story sfr w/attached garage	2010
New	Approved	basic 09-102879 BP	2006 IRC	Plan# 627	2-story sfr w/attached garage	2010
New	Approved	basic 09-102879 BP	2006 IRC	Plan# 627	2-story sfr w/attached garage	2010
New	Approved	basic 09-102879 BP	2006 IRC	Plan# 627	2-story sfr w/attached garage	2010
New	Approved	basic 09-102881 BP	2006 IRC	Plan# 628	2-story sfr w/attached garage	2010
New	Approved	basic 09-102881 BP	2006 IRC	Plan# 628	2-story sfr w/attached garage	2010
New	Approved	basic 09-102881 BP	2006 IRC	Plan# 628	2-story sfr w/attached garage	2010
New	Approved	basic 09-102879 BP	2006 IRC	Plan# 627	2-story sfr w/attached garage	2010

Accessory Dwelling Units

Index # - File Name: 1.0022 - Single Family Dwellings Data\_Snohomish County.pdf

New	Approved basic 09-102881 BP	2006 IRC	Plan# 628	2-story sfr w/attached garage	2010
New	Approved basic 09-102881 BP	2006 IRC	Plan# 628	2-story sfr w/attached garage	2010
New	Approved basic 09-102879 BP	2006 IRC	Plan# 627	2-story sfr w/attached garage	2010
New	Approved basic 09-102879 BP	2006 IRC	Plan# 627	2-story sfr w/attached garage	2010
New	Approved basic 09-102879 BP	2006 IRC	Plan# 627	2-story sfr w/attached garage	2010
New	Approved basic 09-102881 BP	2006 IRC	Plan# 628	2-story sfr w/attached garage	2010
New	Approved basic 09-102879 BP	2006 IRC	Plan# 627	2-story sfr w/attached garage	2010
New	Approved basic 09-102879 BP	2006 IRC	Plan# 627	2-story sfr w/attached garage	2010
New	Approved basic 09-102879 BP	2006 IRC	Plan# 627	2-story sfr w/attached garage	2010
New	Approved basic 09-102879 BP	2006 IRC	Plan# 627	2-story sfr w/attached garage	2010
New	Approved basic 09-102879 BP	2006 IRC	Plan# 627	2-story sfr w/attached garage	2010
New	Approved basic 09-102879 BP	2006 IRC	Plan# 627	2-story sfr w/attached garage	2010
New	Two-story SFR with attached garage - 2009 IRC				2010
New	Approved basic 09-108380 BP	2006 IRC	Plan# Campbell A	2-story sfr w/attached garage	2010
New	Approved basic 09-108161 BP	2006 IRC	Plan# Adams-B	2-story w/attached garage	2010
New	Approved basic 09-108141 BP	2006 IRC	Plan# Omak-B	2-story sfr w/attached garage	2010
New	Approved basic 09-108382 BP	2006 IRC	Plan# Campbell II A	2-story sfr w/attached garage	2010
New	Approved basic 09-108140 BP	2006 IRC	Plan# Omak-A	2-story sfr w/attached garage	2010
New	Approved basic 09-108142 BP	2006 IRC	Plan# Omak II-A	2-story sfr w/attached garage	2010
New	Approved basic 09-108160 BP	2006 IRC	Plan# Adams-A	2-story sfr w/attached garage	2010
New	Approved basic 09-108883 BP	2006 IRC	Plan# Chelan II A	2-story sfr w/attached garage	2010
New	Two story SFR with attached Garage				2010
New	Approved Basic 08-109066-BP	Plan No. 3823-A	2006 IRC	2nd story SFR w/ attached garage	2010
New	Approved Basic 08-109068-BP	Plan No. 3824-A	2006 IRC	2 story SFR w/ attached garage	2010
New	Approved basic 10-100774 BP	2006 IRC	Plan# 1754	2-story sfr w/attached garage	2010
New	Approved basic 09-100630 BP	2006 IRC	Plan#2268-02 AB	2-story sfr w/attached garage	2010
New	Approved Basic 08-106999-BP	2788-02AB	2006 IRC	2 story SFR w/ attached garage	2010
New	Approved Basic 08-103216-BP	Plan No. 2120-02Bv3	2006 IRC	2 story SFR w/ attached garage	2010
New	Approved Basic 07-112054-BP	2006 IRC	Plan # AG2100-02A	2-Story SFR w/ attached garage	2010
New	Approved Basic 08-103215-BP	Plan No. 2120-02Av3	2006 IRC	2 story SFR w/attached garage	2010
New	Two-story Duplex with attached garages - 2006 IRC				2010
New	SFR, two story home with attached garage and covered porch				2010
New	Approved basic 10-103068 BP	2006 IRC	Plan# 2058-02AB	2-story sfr w/attached garage	2010
New	Approved basic 10-103068 BP	2006 IRC	Plan# 2058-02AB	2-story sfr w/attached garage	2010
New	Two-story SFR with attached garage and 453 sf finished basement - 2006 IRC				2010
New	SFR, two story home with attached 3-car garage and covered porch			Engineered by Michael Mitro	2010
New	Two story SFR with attached 4 car garage and covered back porch				2010
New	2 story sfr w/attached garage				2010
New	SFR, two story with attached two car garage and covered porch				2010
New	SFR, rambler style home with attached 3 car garage and covered porch				2010
New	Approved Basic 08-105929-BP	Plan No. 3062	2006 IRC	2 stroy SFR w/ attached garage	2010
New	Approved Basic 10-106196 BP	2009 IRC	Plan # 1409	Rambler SFR w/attached 3-car garage	2010
New	2390 sf rambler with attached garage				2010
New	Approved basic 09-103611 BP	2006 IRC	Plan# 1409	2-story sfr w/attached garage	2010
New	Approved basic 10-104914 BP	2009 IRC	Plan# 2112	2-story sfr w/attached garage	2010
New	Approved Basic 08-108054-BP	Plan No. 2575	2006 IRC	2 story SFR w/ attached garage	2010
New	Approved basic 09-104862 BP	2006 IRC	Plan# 1930-02AD	2-story sfr w/attached garage	2010
New	Approved basic 09-104862 BP	2006 IRC	Plan# 1930-02AD	2-story sfr w/attached garage	2010

Accessory Dwelling Units

Index # - File Name: 1.0022 - Single Family Dwellings Data\_Snohomish County.pdf

New	Approved basic 09-104862 BP	2006 IRC	Plan# 1930-02AD	2-story sfr w/attached ga	2010
New	Approved basic 10-103060 BP	2006 IRC	Plan# 2280-02AB	2-story sfr w/attache	2010
New	Approved basic 10-103064 BP	2006 IRC	Plan# 2158-02AB	2-story sfr w/attached	2010
New	Approved Basic 08-105360-BP	Plan No. 2357-02Av2	2006 IRC	2 story SFR w/ attached	2010
New	2-storySFR w/garage				2010
New	Two story home with unfinished basement and attached two car garage, covered porch and dec				2010
New	Approved Basic 08-103216-BP	Plan No. 2120-02Bv3	2006 IRC	2 story SFR w/ attached garage	2010
New	Approved Basic 07-112054-BP	2006 IRC	Plan # AG2100-02A	2-Story SFR w/ att	2010
New	SFR, two story with attached 3-car garage, 5 bedrooms				2010
New	Approved basic 07-111257BP	2006 IRC	Plan# 1807	2-story sfr w/attached garag	2010
New	Approved basic 07-111257BP	2006 IRC	Plan# 1807	2-story sfr w/attached garag	2010
New	Approved basic 07-111257BP	2006 IRC	Plan# 1807	2-story sfr w/attached garag	2010
New	Approved basic 07-111257BP	2006 IRC	Plan# 1807	2-story sfr w/attached garag	2010
New	Approved basic 07-111257BP	2006 IRC	Plan# 1807	2-story sfr w/attached garag	2010
New	Approved basic 07-111257BP	2006 IRC	Plan# 1807	2-story sfr w/attached garag	2010
New	Approved basic 07-111257BP	2006 IRC	Plan# 1807	2-story sfr w/attached garag	2010
New	3-story sfr w/attached garage				2010
New	3-story sfr w/attached garage				2010
New	3-story sfr w/attached garage				2010
New	3-story sfr w/attached garage				2010
New	Approved basic 07-111255 BP	2006 IRC	Plan# 1785	2-story sfr w/attached gar	2010
New	Approved basic 07-109634 BP	2006 IRC	Plan# 3041/3062	2-story sfr w/attache	2010
New	permit transfered to Western Quality Construction affidavit on file			2-story sfr w/finished baserr	2010
New	2 - story sfr w/attached garage				2010
New	2-story sfr w/attached garage				2010
New	2-story sfr w/unfinished basement w/attached garage				2010
New	Approved Basic 07-112055-BP	2006 IRC	Plan # AG2100-02-B	2-Story SFR w/ at	2010
New	Approved basic 10-107526 BP	2009 IRC	Plan# 1903	Mid entry sfr w/attached garag	2010
New	Approved basic 10-107734 BP	2009 IRC	Plan# 1856	Mid entry sfr w/attached	2010
New	2-story sfr finished basement w/attached garage*****			permit transfer on file to Wester	2010
New	2-story sfr w/finished daylight and attached garage				2010
New	2-story sfr w/attached garage				2010
New	2-story sfr w/attached garage				2010
New	2-story sfr w/attached garage				2010
New	2- story sfr w/attached garage				2010
New	2-story sfr w/attached garage				2010
New	Approved Basic 08-109726-BP	Plan No. 3815-A	2006 IRC	2 story SFR w/ attached garage	2010
New	Approved Basic 08-109068-BP	Plan No. 3824-A	2006 IRC	2 story SFR w/ attached garage	2010
New	Approved Basic 08-109725-BP	Plan No. 3814-AB	2006 IRC	2 story SFR w/ attached garag	2010
New	Approved Basic 08-109727-BP	Plan No. 3815-B	2006 IRC	2 story SFR w/ attached garage	2010
New	Approved Basic 08-109724-BP	Plan No. 3813-AB	2006 IRC	2 story SFR w/ attached garage	2010
New	Approved basic 07-111283 BP	2006 IRC	Plan# 3027Den-C	2-story sfr w/ den & attached	2010
New	Approved Basic 08-109727-BP	Plan No. 3815-B	2006 IRC	2 story SFR w/ attached garage	2010
New	Approved Basic 08-109724-BP	Plan No. 3813-AB	2006 IRC	2 story SFR w/ attached garage	2010
New	Approved Basic 08-109726-BP	Plan No. 3815-A	2006 IRC	2 story SFR w/ attached garage	2010
New	Approved Basic 08-109063-BP	Plan No. 3821-B	2006 IRC	2 story SFR w/ attached garage	2010
New	Approved Basic 08-109724-BP	Plan No. 3813-AB	2006 IRC	2 story SFR w/ attached garage	2010

Accessory Dwelling Units

Index # - File Name: 1.0022 - Single Family Dwellings Data\_Snohomish County.pdf

New	Approved basic 07-108278 BP	2006 IRC	Plan# 4010DenBonus-C	2-story sfr w/ den, bonus r	2010
New	Approved basic 07-108257 BP	2006 IRC	Plan# 3026-A	2-story sfr w/attached ga	2010
New	Approved basic 07-111284 BP	2006 IRC	Plan# 3027Den-D	2-story sfr w/ den & attached	2010
New	Approved Basic 08-109063-BP	Plan No. 3821-B	2006 IRC	2 story SFR w/ attached garage	2010
New	Approved Basic 08-109069-BP	Plan No. 3824-B	2006 IRC	2 story SFR w/ attached garage	2010
New	Approved basic 07-108277 BP	2006 IRC	Plan# 4010DenBonus-B	2-story sfr w/ den, bonus r	2010
New	Approved basic 07-108257 BP	2006 IRC	Plan# 3026-A	2-story sfr w/attached ga	2010
New	Approved basic 10-106847 BP	2009 IRC	Plan# 1883 40#	2-story sfr w/attached	2010
New	Approved basic 10-106427 BP	2009 IRC	Plan# 1529 40#	2-story sfr w/attached gar	2010
New	Approved basic 10-108132 BP	2009 IRC	Plan# 2588	2-story sfr w/attached garage	2010
New	2-story sfr w/attached garage				2010
New	Approved basic 10-101741 BP	2006 IRC	Plan# 2306	2-story sfr w/attached gara	2010
New	Approved basic 10-101738 BP	2006 IRC	Plan# 2160	2-story sfr w/attached gar	2010
New	Approved basic 10-101738 BP	2006 IRC	Plan# 2160	2-story sfr w/attached gar	2010
New	Two-story Duplex - 2006 IRC				2010
New	Rambler SFR w/garage & covered deck				2010
New	Approved Basic 08-109727-BP	Plan No. 3815-B	2006 IRC	2 story SFR w/ attached garage	2010
New	Approved Basic 08-109067-BP	Plan No. 3823-B	2006 IRC	2 story SFR w/ attached garage	2010
New	Approved Basic 08-109725-BP	Plan No. 3814-AB	2006 IRC	2 story SFR w/ attached garag	2010
New	Approved Basic 08-109063-BP	Plan No. 3821-B	2006 IRC	2 story SFR w/ attached garage	2010
New	Approved Basic 08-109063-BP	Plan No. 3821-B	2006 IRC	2 story SFR w/ attached garage	2010
New	Approved Basic 08-109066-BP	Plan No. 3823-A	2006 IRC	2nd story SFR w/ attached garag	2010
New	Approved Basic 08-109065-BP	Plan No. 3822-B	2006 IRC	2 story SFR w/ attached garage	2010
New	Approved Basic 08-109069-BP	Plan No. 3824-B	2006 IRC	2 story SFR w/ attached garage	2010
New	Approved Basic 08-109062-BP	Plan No 3821-A	2006 IRC	2 story SFR w/ attached garage	2010
New	Approved Basic 08-109725-BP	Plan No. 3814-AB	2006 IRC	2 story SFR w/ attached garag	2010
New	Approved Basic 08-109067-BP	Plan No. 3823-B	2006 IRC	2 story SFR w/ attached garage	2010
New	Approved Basic 08-104186-BP	Plan No 2870	2006 IRC	2 story SFR w/ attached garage	2010
New	Approved Basic 08-100887-BP	Plan No 2548	2006 IRC / Perscriptive	1 story w/ 3 car garag	2010
New	Approved basic 10-106847 BP	2009 IRC	Plan# 1883 40#	2-story sfr w/attached	2010
New	Approved basic 10-106847 BP	2009 IRC	Plan# 1883 40#	2-story sfr w/attached	2010
New	Approved basic 10-106847 BP	2009 IRC	Plan# 1883 40#	2-story sfr w/attached	2010
New	Approved basic 10-106427 BP	2009 IRC	Plan# 1529 40#	2-story sfr w/attached gara	2010
New	Approved basic 10-106847 BP	2009 IRC	Plan# 1883 40#	2-story sfr w/attached	2010
New	Approved basic 10-106847 BP	2009 IRC	Plan# 1883 40#	2-story sfr w/attached	2010
New	Approved basic 10-106847 BP	2009 IRC	Plan# 1883 40#	2-story sfr w/attached	2010
New	Approved basic 10-106847 BP	2009 IRC	Plan# 1883 40#	2-story sfr w/attached	2010
New	Approved basic 10-107670 BP	2009 IRC	Plan# 1238 40#	2-story sfr w/attached	2010
New	Approved basic 10-106427 BP	2009 IRC	Plan# 1529 40#	2-story sfr w/attached gara	2010
New	Approved basic 10-106427 BP	2009 IRC	Plan# 1529 40#	2-story sfr w/attached gara	2010
New	Approved basic 10-107670 BP	2009 IRC	Plan# 1238 40#	2-story sfr w/attached	2010
New	Approved basic 10-106427 BP	2009 IRC	Plan# 1529 40#	2-story sfr w/attached gara	2010
New	2013 sf SFR with attached garage - 2009 IRC				2010
New	Log cabin style home, single story (no attached garage)				2010
New	2 story home w/ attached 2 car garage				2010
New	Approved Basic 07-111814-BP	Plan No 2734 A	2006 IRC	2 story SFR w/ attached g	2010
New	Approved Basic 07-111784-BP	Plan No. 2140 A	2006 IRC	2 story SFR w Attached G	2010
New	Approved Basic 07-111809-BP	Plan No. 3036 B	2006 IRC	2 story SFR w/ attached ga	2010

Accessory Dwelling Units

Index # - File Name: 1.0022 - Single Family Dwellings Data\_Snohomish County.pdf

New	Approved basic 10-105911 BP	2009 IRC	Plan#2140-02A-09	2-story sfr w/attached g	2010
New	Approved Basic 07-111814-BP	Plan No 2734 A	2006 IRC	2 story SFR w/ attached g	2010
New	Approved Basic 08-104586-BP	Plan No. 2598 AB	2006 IRC	2 story sfr w/ attached 3 car gara	2010
New	Approved basic 10-107094 BP	2009 IRC	Plan# 2734A-09	2-story sfr w/attached ga	2010
New	Approved basic 10-107801 BP	2009 IRC	Plan# 3117C-09	2-story sfr w/attache	2010
New	Approved Basic 08-108951 BP	2006 IBC	Plan: 2042B	Two-stor	2010
New	Approved basic 10-107469 BP	2009 IRC	Plan# 3036A-09	2-story sfr w/attached g	2010
New	Approved basic 10-106613 BP	2009 IRC	Plan# 2610AB	2-story sfr w/attached	2010
New	Approved Basic 07-111794	Plan No. 2472 A	2006 IRC	2 story SFR w/attached garage	2010
New	Approved Basic 07-111784-BP	Plan No. 2140 A	2006 IRC	2 story SFR w Attached G	2010
New	Approved Basic 07-111790-BP	Plan No. 2440A - EF	2006 IRC	2 story SFR w/ Attached g	2010
New	Approved Basic 07-108411-BP	Builder s plan No: 2440A	2006 IRC	2 story SFR w	2010
New	Approved Basic Plan 10-105979 BP	2009 IRC	Plan# 2042 A/B/C-09N	2-story s	2010
New	Approved Basic Plan 10-105979 BP	2009 IRC	Plan# 2042 A/B/C-09N	2-story s	2010
New	Approved Basic 08-104586-BP	Plan No. 2598 AB	2006 IRC	2 story sfr w/ attached 3 car gara	2010
New	2-story sfr w/attic and w/attached garage				2010
New	2-story sfr w/attached garage				2010
New	2-story sfr w/attached garage				2010
New	2-story sfr w/attached garage				2010
New	Two story home w/ covered porch				2010
New	512 sf sfr with 192 sf 2nd floor storage room, 1024 sf garage and 768 sf carport				2010
New	Two-story SFR with finished basement and attached garage				2010
New	Approved Basic 07-108874-BP	Builider No. 3	2006 IRC	2 story SFR w/ attahced gara	2010
New	Approved Basic 10-102725BP	2006 IRC	Plan: 1892M Elevations A&B	2-story SFR w/atti	2010
New	Two-story SFR with attached garage - 2006 IRC				2010
New	Two-story SFR with attached garage - 2006 IRC				2010
New	Approved Basic 10- 102728 BP	Plan: 2064	2006 IRC	Two-story SFR with attached ;	2010
New	Approved Basic 10-102911BP	Two-story SFR with attached garage	2006 IRC	Plan: 220	2010
New	2-story sfr w/attached garage				2010
New	Two-story SFR with attached garage - 2006 IRC				2010
New	Two-story SFR with attached garage - 2006 IRC				2010
New	Approved Basic 10- 102728 BP	Plan: 2064	2006 IRC	Two-story SFR with attached ;	2010
New	Two-story SFR with attached garage - 2006 IRC				2010
New	Two-story SFR with attached garage - 2006 IRC				2010
New	SFR, two story with attached 2-car garage				2010
New	Approved Basic 07-108875-BP	Builder no. 4	2006 IRC	2 story SFR w/ attached garage	2010
New	Approved Basic 10-102912BP	Two-story SFR with attached garage	2006 IRC	Plan: 22	2010
New	2-story sfr w/attached garage				2010
New	SFR, two story style home with attached two car garage				2010
New	2-story sfr w/attached garage				2010
New	2-story sfr w/attached garage				2010
New	Approved Basic 08-100937-BP	Plan No 2075 B	2006 IRC	2 story SFR w/ attached gara	2010
New	Approved basic 09-108351 BP	2006 IRC	Plan# 1814 C	2-story sfr w/attached garag	2010
New	SFR, two story style home with attached two car garage				2010
New	Approved basic 10-103507 BP	2009 IRC	Plan# 2420-A	2-story sfr w/attached gar	2010
New	Approved basic 10-103499 BP	2009 IRC	Plan# 3015-B	2-story sfr w/attached gar	2010
New	Approved basic 10-103501 BP	2009 IRC	Plan# 3012-B	2-story sfr w/attached gar	2010

Accessory Dwelling Units

Index # - File Name: 1.0022 - Single Family Dwellings Data\_Snohomish County.pdf

New	Approved basic 10-103499 BP	2009 IRC	Plan# 3015-B/C	2-story sfr w/attached g	2010
New	Approved basic 10-103497 BP	2009 IRC	Plan# 3570-E	2-story sfr w/attached g	2010
New	Approved basic 10-103501 BP	2009 IRC	Plan# 3012-B	2-story sfr w/attached gar	2010
New	Approved basic 10-103502 BP	2009 IRC	Plan# 3012-A	2-story sfr w/attached ga	2010
New	Approved basic 10-103499 BP	2009 IRC	Plan# 3015-B/C	2-story sfr w/attached g	2010
New	Approved basic 10-103505 BP	2009 IRC	Plan# 2420-B	2-story sfr w/attached	2010
New	Approved basic 10-103499 BP	2009 IRC	Plan# 3015-B	2-story sfr w/attached gar	2010
New	Approved basic 10-103507 BP	2009 IRC	Plan# 2420-A	2-story sfr w/attached gar	2010
New	Approved basic 10-103500 BP	2009 IRC	Plan# 3015-A	2-story sfr w/attached ga	2010
New	Approved basic 10-103499 BP	2009 IRC	Plan# 3015-B	2-story sfr w/attached gar	2010
New	Approved basic 10-103501 BP	2009 IRC	Plan# 3012-B	2-story sfr w/attached gar	2010
New	Approved basic 10-103499 BP	2009 IRC	Plan# 3015-B/C	2-story sfr w/attached g	2010
New	Approved basic 10-103502 BP	2009 IRC	Plan# 3012-A	2-story sfr w/attached ga	2010
New	Approved basic 10-103500 BP	2009 IRC	Plan# 3015-A	2-story sfr w/attached ga	2010
New	Approved basic 10-103502 BP	2009 IRC	Plan# 3012-A	2-story sfr w/attached ga	2010
New	Approved basic 10-103502 BP	2009 IRC	Plan# 3012-A	2-story sfr w/attached ga	2010
New	Approved basic 10-103500 BP	2009 IRC	Plan# 3015-A	2-story sfr w/attached ga	2010
New	Approved basic 10-103501 BP	2009 IRC	Plan# 3012-B	2-story sfr w/attached gar	2010
New	Approved basic 10-103507 BP	2009 IRC	Plan# 2420-A	2-story sfr w/attached gar	2010
New	Two story style home with attached 2-car garage				2010
New	Approved basic 10-103499 BP	2009 IRC	Plan# 3015-B	2-story sfr w/attached gar	2010
New	Approved basic 10-103501 BP	2009 IRC	Plan# 3012-B	2-story sfr w/attached gar	2010
New	Approved Basic 07-112523-BP	2006 IRC	Plan # 2141 C	2-Story SFR w/ attached g	2010
New	2-story sfr w/attached garage				2010
New	2-story sfr w/attached garage				2010
New	2-story sfr w/attached garage				2010
New	Approved basic 10-103501 BP	2009 IRC	Plan# 3012-B	2-story sfr w/attached gar	2010
New	Approved basic 10-103507 BP	2009 IRC	Plan# 2420-A	2-story sfr w/attached gar	2010
New	Approved basic 10-103499 BP	2009 IRC	Plan# 3015-B	2-story sfr w/attached gar	2010
New	Approved basic 10-103507 BP	2009 IRC	Plan# 2420-A	2-story sfr w/attached gar	2010
New	Approved basic 10-103500 BP	2009 IRC	Plan# 3015-A	2-story sfr w/attached ga	2010
New	Approved basic 10-103502 BP	2009 IRC	Plan# 3012-A	2-story sfr w/attached ga	2010
New	Approved basic 10-103499 BP	2009 IRC	Plan# 3015-B	2-story sfr w/attached gar	2010
New	Approved basic 10-103499 BP	2009 IRC	Plan# 3015-B	2-story sfr w/attached gar	2010
New	Approved basic 10-103501 BP	2009 IRC	Plan# 3012-B	2-story sfr w/attached gar	2010
New	Approved basic 10-103499 BP	2009 IRC	Plan# 3015-B	2-story sfr w/attached gar	2010
New	Approved basic 10-103499 BP	2009 IRC	Plan# 3015-B	2-story sfr w/attached gar	2010
New	Approved basic 10-103496 BP	2009 IRC	Plan# 3570-D	2-story sfr w/attached g	2010
New	Approved basic 10-103502 BP	2009 IRC	Plan# 3012-A	2-story sfr w/attached ga	2010
New	Approved basic 10-103499 BP	2009 IRC	Plan# 3015-B	2-story sfr w/attached gar	2010
New	Approved basic 10-103505 BP	2009 IRC	Plan# 2420-B	2-story sfr w/attached	2010
New	Approved basic 10-103501 BP	2009 IRC	Plan# 3012-B	2-story sfr w/attached gar	2010
New	Approved basic 10-103507 BP	2009 IRC	Plan# 2420-A	2-story sfr w/attached gar	2010
New	Approved basic 10-103500 BP	2009 IRC	Plan# 3015-A	2-story sfr w/attached ga	2010
New	Approved basic 10-103499 BP	2009 IRC	Plan# 3015-B	2-story sfr w/attached gar	2010
New	Approved basic 10-103502 BP	2009 IRC	Plan# 3012-A	2-story sfr w/attached ga	2010
New	Approved Basic 07-112054-BP	2006 IRC	Plan # AG2100-02A	2-Story SFR w/ att	2010

Accessory Dwelling Units

Index # - File Name: 1.0022 - Single Family Dwellings Data\_Snohomish County.pdf

New	Approved Basic 08-103216-BP	Plan No. 2120-02Bv3	2006 IRC	2 story SFR w/ attached garage	2010
New	Approved Basic 08-103215-BP	Plan No. 2120-02Av3	2006 IRC	2 story SFR w/attached	2010
New	Approved Basic 10-107346 BP	2009 IRC	Plan# 2120-02A	2-story sfr w/attache	2010
New	Approved Basic 08-103216-BP	Plan No. 2120-02Bv3	2006 IRC	2 story SFR w/ attached garage	2010
New	Approved Basic 08-103215-BP	Plan No. 2120-02Av3	2006 IRC	2 story SFR w/attached	2010
New	Approved basic 09-100630 BP	2006 IRC	Plan#2268-02 AB	2-story sfr w/attached gar	2010
New	Approved Basic 08-105360-BP	Plan No. 2357-02Av2	2006 IRC	2 story SFR w/ attached	2010
New	Approved basic 09-104862 BP	2006 IRC	Plan# 1930-02AD	2-story sfr w/attached ga	2010
New	Approved Basic 07-112055-BP	2006 IRC	Plan # AG2100-02-B	2-Story SFR w/ ati	2010
New	Approved Basic 08-105360-BP	Plan No. 2357-02Av2	2006 IRC	2 story SFR w/ attached	2010
New	Two story style home with daylight basement and attached 3-car garage (4 bedrooms)				2010
New	Approved basic 09-100630 BP	2006 IRC	Plan#2268-02 AB	2-story sfr w/attached gar	2010
New	Approved Basic 08-106996-BP	Plan No. 2368-03AB	2006 IRC	3 story SFR w/ 1st stroy gar	2010
New	Approved Basic 08-106996-BP	Plan No. 2368-03AB	2006 IRC	3 story SFR w/ 1st stroy gar	2010
New	Approved Basic 08-103216-BP	Plan No. 2120-02Bv3	2006 IRC	2 story SFR w/ attached garage	2010
New	Approved Basic 07-112054-BP	2006 IRC	Plan # AG2100-02A	2-Story SFR w/ att	2010
New	Approved Basic 07-112055-BP	2006 IRC	Plan # AG2100-02-B	2-Story SFR w/ ati	2010
New	2-story sfr w/attached garage				2010
New	2-story sfr w/attached garage				2010
New	2-story sfr w/attached garage				2010
New	Approved Basic 08-111009 BP	Plan: 1633	2006 IRC	1633 sq ft Rambler with attached Ga	2010
New	Approved basic 09-103398 BP	2006 IRC	Plan# Steen Plan C	2-story sfr w/attached	2010
New	Approved Basic # 07-108991 BP	2006 IRC	Plan # 2037-A (Was listed as 2140, Changed to 2037)	2-story sfr w/attached	2010
New	Approved Basic 08-109068-BP	Plan No. 3824-A	2006 IRC	2 story SFR w/ attached garage	2010
New	Approved Basic 08-109062-BP	Plan No 3821-A	2006 IRC	2 story SFR w/ attached garage	2010
New	Approved Basic 08-109065-BP	Plan No. 3822-B	2006 IRC	2 story SFR w/ attached garage	2010
New	Approved Basic 08-109069-BP	Plan No. 3824-B	2006 IRC	2 story SFR w/ attached garage	2010
New	Approved Basic 08-109063-BP	Plan No. 3821-B	2006 IRC	2 story SFR w/ attached garage	2010
New	Approved Basic 08-111194-BP	Plan No. 3803-B	2006 IRC	2 story SFR w/ attached g	2010
New	Approved basic 09-102932 BP	2006 IRC	Plan# 3806 A/B	2-story sfr w/attached gar	2010
New	Approved Basic 08-111195-BP	Plan No. 3804-AB	2006 IRC	2 story SFR w/ attached g	2010
New	Approved Basic 08-109067-BP	Plan No. 3823-B	2006 IRC	2 story SFR w/ attached garage	2010
New	Approved basic 09-104024 BP	2006 IRC	Plan# 3801/3801 opt bath-A	2-story sfr w/attach	2010
New	Approved basic 09-102932 BP	2006 IRC	Plan# 3806 A/B	2-story sfr w/attached gar	2010
New	Approved Basic 08-111196-BP	Plan No. 3805-AB	2006 IRC	2 story SFR w/ attached ga	2010
New	Approved Basic 08-111195-BP	Plan No. 3804-AB	2006 IRC	2 story SFR w/ attached g	2010
New	Approved Basic 08-111194-BP	Plan No. 3803-B	2006 IRC	2 story SFR w/ attached g	2010
New	Approved Basic 08-109068-BP	Plan No. 3824-A	2006 IRC	2 story SFR w/ attached garage	2010
New	Approved Basic 08-109064-BP	Plan No. 3822-A	2006 IRC	2 story SFR w/ attached garage	2010
New	Approved Basic 08-109066-BP	Plan No. 3823-A	2006 IRC	2nd story SFR w/ attached garage	2010
New	2-story sfr w/attached garage				2010
New	2-story sfr w/attached garage				2010
New	Approved Basic #07-107306 BP	2006 IRC	Plan B-2781	Two Story SFR w/attached garage	2010
New	Approved Basic 07-112450 BP	2006 IRC		Plan: 1988 Plan C	2010
New	Approved Basic # 07-108991 BP	2006 IRC	Plan # 2037-A (Was listed as 2140, Changed to 2037)	2-story sfr w/attached	2010
New	Approved basic 09-103398 BP	2006 IRC	Plan# Steen Plan C	2-story sfr w/attached	2010
New	Two story, 4 bedroom home with attached 2 car garage				2010



Accessory Dwelling Units

Index # - File Name: 1.0022 - Single Family Dwellings Data\_Snohomish County.pdf

New	Permits reinstated per Tom Rowe. letter in micro film. 12-14-2010 jrlind //	Permit Withdra	2010
New	Permits reinstated per Tom Rowe. letter in micro film. 12-14-2010 jrlind //	permit Withdra	2010
New	Permits reinstated per Tom Rowe. letter in micro film. 12-14-2010 jrlind //	permit Withdra	2010
New	Permits reinstated per Tom Rowe. letter in micro film. 12-14-2010 jrlind //	permit Withdra	2010
New	Permits reinstated per Tom Rowe. letter in micro film. 12-14-2010 jrlind //	permit Withdra	2010
New	Permits reinstated per Tom Rowe. letter in micro film. 12-14-2010 jrlind //	permit Withdra	2010
New	Approved Basic 08-108823-BP Plan No. Summerlin (2) 2006 IRC	2 story SFR w/ attached	2010
New	Approved Basic 08-108822-BP Plan No. Elliston (2) 2006 IRC	2 story SFR w/attached garage	2010
New	Approved Basic 08-105019-BP Plan No. Glenbrook 2 2006 IRC	2 story SFR w/ attached garage	2010
New	Approved basic 09-100390 BP 2006 IRC Plan# Auburn	2-story sfr w/attached ga	2010
New	Approved Basic 08-105539 BP 2006 IBC	Plan: Summerli	2010
New	2-story sfr w/attached garage		2010
New	2-story sfr w/attached garage		2010
New	Approved basic 09-100390 BP 2006 IRC Plan# Auburn	2-story sfr w/attached ga	2010
New	Approved basic 10-108667 BP 2009 IRC Plan# 2539 - 25#	2-story w/attached garage	2010
New	Approved basic 10-108080 BP 2009 IRC Plan# 2390 25#	2-story sfr w/attached	2010
New	Approved basic 10-108080 BP 2009 IRC Plan# 2390 25#	2-story sfr w/attache	2010
New	Approved Basic 08-111009 BP Plan: 1633 2006 IRC 1633 sq ft	Rambler with attached Ga	2010
New	Approved basic 09-100390 BP 2006 IRC Plan# Auburn	2-story sfr w/attached ga	2010
New	Approved Basic 08-108824-BP Plan No. Brighton (2) 2006 IRC	2 Story SFR w/ attached	2010
New	Approved Basic 07-111371-BP 2006 IRC Plan # 2042	2- Story SFR w/ attached ga	2010
New	Approved basic 07-111958 BP 2006 IRC Plan# 2338	2-story sfr w/attached garage	2010
New	Approved basic 07-111957 BP 2006 IRC Plan# 226-1001	2-story sfr w/attache	2010
New	Approved basic 07-111958 BP 2006 IRC Plan# 2338	2-story sfr w/attached garage	2010
New	Approved basic 07-111956 BP 2006 IRC Plan# 226-1007	2-story sfr w/attached g	2010
New	Approved basic 07-111958 BP 2006 IRC Plan# 2338	2-story sfr w/attached garage	2010
New	Approved basic 10-108667 BP 2009 IRC Plan# 2539 - 25#	2-story w/attached garage	2010
New	SFR, Two story home with attached 2-car garage		2010
New	Approved basic 07-111958 BP 2006 IRC Plan# 2338	2-story sfr w/attached garage	2010
New	Approved basic 10-106996 BP 2009 IRC Plan# Kitsap A	2-story sfr w/attached gar	2010
New	Approved basic 10-106997 BP 2009 IRC Plan# Newman A	2-story sfr w/attach	2010
New	Approved basic 10-106958 BP 2009 IRC Plan# Rainier B	2-story sfr w/attached gar	2010
New	Approved basic 10-107478 BP 2009 IRC Plan# Jameson A	2-story sfr w/attached g	2010
New	Approved basic 10-105529 BP 2009 IRC Plan# Baker A	2-story sfr w/attached gar	2010
New	Approved basic 10-106962 BP 2009 IRC Plan # Adams A	2-story sfr w/attached ga	2010
New	Approved basic 07-111957 BP 2006 IRC Plan# 226-1001	2-story sfr w/attache	2010
New	Approved basic 07-111958 BP 2006 IRC Plan# 2338	2-story sfr w/attached garage	2010
New	Approved basic 07-111957 BP 2006 IRC Plan# 226-1001	2-story sfr w/attache	2010
New	Approved basic 07-111956 BP 2006 IRC Plan# 226-1007	2-story sfr w/attached g	2010
New	Approved basic 10-107475 BP 2009 IRC Plan# Franklin B	2-story sfr w/attached	2010
New	Approved basic 10-107476 BP 2009 IRC Plan# Rainer A	2-story sfr w/attached gara	2010
New	Approved basic 10-107477 BP 2009 IRC Plan# Dayton A	2-story sfr w/attached gara	2010
New	Approved basic 10-106958 BP 2009 IRC Plan# Rainier B	2-story sfr w/attached gar	2010
New	Approved basic 10-106996 BP 2009 IRC Plan# Kitsap A	2-story sfr w/attached gara	2010
New	converting existing TD to permanent dwelling on new lot created through short plat		2010
New	Two story home with attached 2-car garage		2010
New	Two story home with attached 2-car garage		2010

Accessory Dwelling Units

Index # - File Name: 1.0022 - Single Family Dwellings Data\_Snohomish County.pdf

New	Two story home with attached 2-car garage				2010
New	Approved basic 09-108126 BP	2006 IRC	Plan# 2501 B	2-story sfr w/attached gar	2010
New	Approved basic 09-108123 BP	2006 IRC	Plan# 2647 b	2-story sfr w/attached ga	2010
New	SFR, two story style home with attached 2 car garage, 4 bedrooms				2010
New	Approved basic 10-106949 BP	2009 IRC	Plan #2269 - 25#	2-story sfr w/attached garag	2010
New	Approved basic 10-106949 BP	2009 IRC	Plan #2269 - 25#	2-story sfr w/attached garag	2010
New	Approved basic 10-103507 BP	2009 IRC	Plan# 2420-A	2-story sfr w/attached gar	2010
New	Approved basic 10-103502 BP	2009 IRC	Plan# 3012-A	2-story sfr w/attached ga	2010
New	Approved basic 10-103507 BP	2009 IRC	Plan# 2420-A	2-story sfr w/attached gar	2010
New	Approved basic 10-103499 BP	2009 IRC	Plan# 3015-B	2-story sfr w/attached gar	2010
New	Approved basic 10-106263 BP	2009 IRC	Plan# 2023 VT	2-story sfr w/attached gara	2010
New	Approved basic 10-106261 BP	2009 IRC	Plan# 1670 VT	2-story sfr w/attached garag	2010
New	Approved basic 10-106263 BP	2009 IRC	Plan# 2023 VT	2-story sfr w/attached gara	2010
New	Approved basic 10-106262 BP	2009 IRC	Plan# 1987 VT	2-story sfr w/attached garage	2010
New	Approved basic 10-106263 BP	2009 IRC	Plan# 2023 VT	2-story sfr w/attached gara	2010
New	Approved basic 10-106262 BP	2009 IRC	Plan# 1987 VT	2-story sfr w/attached garag	2010
New	Approved basic 10-106263 BP	2009 IRC	Plan# 2023 VT	2-story sfr w/attached gara	2010
New	Approved basic 10-106263 BP	2009 IRC	Plan# 2023 VT	2-story sfr w/attached gara	2010
New	Approved basic 10-106262 BP	2009 IRC	Plan# 1987 VT	2-story sfr w/attached garage	2010
New	SFR, rambler style (no garage) 3 bedrooms (ref 10-104245 RK to convert exist g SFR on 2nd floor				2010
New	Approved Basic 07-110568-BP	Builder No. 1511A	2006 IRC / WSEC	2 story SFR w/ att	2010
New	Approved Basic 07-109652-BP	Builder No. 2343 A	2006 IRC / WSEC	2 story SFR with a	2010
New	Approved basic 10-100637 BP	2006 IRC	Plan# 1814 B	2-story sfr w/attached gara	2010
New	2-story sfr w/attached garage				2010
New	Approved Basic 07-109652-BP	Builder No. 2343 A	2006 IRC / WSEC	2 story SFR with a	2010
New	Approved Basic 07-112511-BP	2006 IRC	Plan # 1323 A	2-Story SFR w/ attached g	2010
New	Approved Basic 07-113579-BP	Plan 2411 B	2006 IRC	2 story SFR w/ 2 or 3 car option	2010
New	2 Story single family residence with attached 2-car garage. Plan #1814E				2010
New	Approved Basic 08-100953-BP	Plan No 2421 B	2006 IRC	2 story SFR w/ attached ga	2010
New	Reconfigure kithcen layout , mstr bath, move doorways, laundry & hall changes from previously				2010
New	Approved Basic 07-110570-BP	Builder No. 1511B	2006 IRC / WSEC	2 story SFR w/ att	2010
New	Approved Basic 07-110119-BP	2006 IRC	Plan # 2421 A	2-Story SFR w/ attached g	2010
New	Approved basic 09-108169 BP	2006 IRC	Plan# 1834 C	2-story sfr w/attached gara	2010
New	Approved basic 09-108351 BP	2006 IRC	Plan# 1814 C	2-story sfr w/attached garag	2010
New	2-story sfr w/attached garage				2010
New	2- story sfr w/attached garage				2010
New	Approved basic 07-112903 BP	2006 IRC	Plan# 2131 A	2-story sfr w/attached gar	2010
New	2-story sfr w/attached garage				2010
New	Approved basic 09-104259 BP	2006 IRC	Plan# 1273	2-story sfr w/attached garage	2010
New	Approved basic 09-104259 BP	2006 IRC	Plan# 1273	2-story sfr w/attached garage	2010
New	Approved basic 09-104260 BP	2006 IRC	Plan# 1618	2-story sfr w/attached gar	2010
New	Approved basic 09-104831 BP	2006 IRC	Plan# 1777	2-story sfr w/attached garage	2010
New	Approved basic 09-104260 BP	2006 IRC	Plan# 1618	2-story sfr w/attached gar	2010
New	2-story sfr w/attached garage				2010
New	2-story sfr w/attached garage				2010
New	Two-story SFR with attached garage	2006 IRC			2010
New	2-story sfr w/attached garage				2010
New	Two story SFR				2010

Accessory Dwelling Units

Index # - File Name: 1.0022 - Single Family Dwellings Data\_Snohomish County.pdf

New	Approved basic 10-100320 BP	2006 IRC	Plan# Julia	2-story sfr w/attached garage	2010
New	Two-story SFR with attached garage - 2006 IRC				2010
New	2009 Marlette/8249 Mobile Home				2010
New	New two story townhome with attached 2-car garage 2006 IRC Compliant townhouse (2) 1-Hou				2010
New	New two story townhome with attached 2-car garage 2006 IRC Compliant townhouse (2) 1-Hou				2010
New	New two story townhouse with attached 2-car garage 2006 IRC Compliant townhouse (2) 1-Hou				2010
New	Approved basic 09-107878 BP	2006 IRC	Plan# 1775	2-story sfr w/attached garage	2010
New	Approved basic 09-107878 BP	2006 IRC	Plan# 1775	2-story sfr w/attached garage	2010
New	Approved Basic 09-107450BP	2006 IRC	Plan# 1538	2-story SFR w/attached garage	2010
New	Approved Basic 09-107450BP	2006 IRC	Plan# 1538	2-story SFR w/attached garage	2010
New	Approved Basic 08-111195-BP	Plan No. 3804-AB	2006 IRC	2 story SFR w/ attached garage	2010
New	Approved basic 09-102932 BP	2006 IRC	Plan# 3806 A/B	2-story sfr w/attached garage	2010
New	Approved Basic 08-111194-BP	Plan No. 3803-B	2006 IRC	2 story SFR w/ attached garage	2010
New	Approved Basic 08-111195-BP	Plan No. 3804-AB	2006 IRC	2 story SFR w/ attached garage	2010
New	Approved basic 09-104027 BP	2006 IRC	Plan# 3820 B	2-story sfr w/attached garage	2010
New	Approved basic 09-102932 BP	2006 IRC	Plan# 3806 A/B	2-story sfr w/attached garage	2010
New	Approved Basic 08-111195-BP	Plan No. 3804-AB	2006 IRC	2 story SFR w/ attached garage	2010
New	Approved Basic 08-111196-BP	Plan No. 3805-AB	2006 IRC	2 story SFR w/ attached garage	2010
New	Approved basic 09-104025 BP	2006 IRC	Plan# 3801/3801 opt bath B	2-story sfr w/attached garage	2010
New	Approved Basic 08-111195-BP	Plan No. 3804-AB	2006 IRC	2 story SFR w/ attached garage	2010
New	Approved basic 09-104024 BP	2006 IRC	Plan# 3801/3801 opt bath-A	2-story sfr w/attached garage	2010
New	Approved Basic 08-111193-BP	Plan No. 3803-A	2006 IRC	2 story SFR w/ attached garage	2010
New	Approved Basic 08-111193-BP	Plan No. 3803-A	2006 IRC	2 story SFR w/ attached garage	2010
New	Approved Basic 08-111196-BP	Plan No. 3805-AB	2006 IRC	2 story SFR w/ attached garage	2010
New	Approved basic 10-108080 BP	2009 IRC	Plan# 2390 25#	2-story sfr w/attached garage	2010
New	Approved basic 10-108496 BP	2009 IRC	Plan# 2089 - 25#	Rambler style sfr w/attached garage	2010
New	Two-story SFR with attached garage - 2006 IRC				2010
New	720 sf detached accessory apartment with 100 sf craft room on 2nd floor - 2009 IRC				2010
New	Approved basic 10-106949 BP	2009 IRC	Plan #2269 - 25#	2-story sfr w/attached garage	2010
New	Two story with attached garage, bonus room and covered porches.				2010
New	SFR with finished daylight basement and attached garage - 2006 IRC				2010
New	2432 sf rambler with 624 sf attached garage - 2009 IRC				2010
New	requested 30 day extension (original expire date 4/30/12) 5/11/12 dm 2-Story SFR w/attached garage				2010
New	Two-story exercise building				2010
New					2010
New	2 story sfr w/attached garage				2010
New	Two-Story SFR with attached garage - 2006 IRC				2010
New	850 sf detached accessory apartment with 500 sf garage and 438 sf covered porch				2010
New	4/9/12 allowing 30 day extension to obtain final inspection per H Faller. (new expire date will be 5/11/12)				2010
New	Two story with finished basement and attached 3 car garage				2010
New	Proposed Detached Garage with detached accessory apartment				2010
New	Detached accessory apartment w/attached garage and stalls				2010
New	New residence - 2 story with attached two car garage				2010
New	30 day grace period per applicant, (7/13/12) ss. 2-story Single family Residence w/finished basement				2010
New	1950sf rambler-style sfr with attached garage - 2006 IRC				2010
New	Two-story SFR with attached garage - 2006 IRC				2010
New	Two-story SFR with attached garage 2006 IRC				2010

Accessory Dwelling Units

Index # - File Name: 1.0022 - Single Family Dwellings Data\_Snohomish County.pdf

New	Two-story sfr with 993sf finished basement and attached garage - 2009 IRC	2010
New	new MH that will be connected by breezeway to new garage ( see 10-105518-AB) Existing old s	2010
New	Single Family Residence - two story with finished basement	2010
New	Two-story SFR with attached garage - 2006 IRC	2010
New	SFR, 2 story home with attached garage with covered porch	2010
New	Mobile home, 40 x 68, 2007 Fleetwood	2010
New	1829 sf Rambler - 2009 IRC	2010
New	REVERSED EXPIRED STATUS TO ALLOW FOR A ONE TIME FINAL INSPECTION 10/13/12 DM 10/1	2010
New	Two story home with attached two car garage and covered porch	2010
New	Two-story SFR - 2006 IRC	2010
New	1200 sq ft Rambler with attached Garage To finish work on expired permit # 99-112273 RK	2010
New	Rambler style sfr w/attached garage	2010
New	Two story SFR with attached Garage	2010
New	Approved basic 09-106885 BP 2006 IRC Plan# 2195 Rambler daylight w/ga	2010
New	Detached accessory apartment, 2 bedrooms approx 848 sqft	2010
New	SFR, 2 story home w/ attached 3 car garage	2010
New	803 sf detached accessory apartment with 704 sf unfinished basement LUB AFN 201001120512	2010
New	Rambler style home with attached one car garage, 3 bedrooms	2010
New	SFR, main floor garage and 2nd floor living space with 2nd floor deck	2010
New	1920 sq ft SFR with Unfinished Basement & attached Garage	2010
New	2-story sfr w/attached garage	2010
New	2 story SFR w/ attaching to existing garage	2010
New	SFR, Rambler with covered porch and attached 3-car garage	2010
New	Accessory Apartment 24ft x 26ft, 624 sqft	2010
New	Dave - I have set my project behind schedule. I would like to request a 30 day extension to finish	2010
New	Rambler w/daylight basement w/attached garage	2010
New	SFR, two story home with attached 2-car garage and covered porch	2010
New	Two story SFR with finished basement and attached garage - 2006 IRC	2010
New	2 story SFR w/unfinished basement and garage;	2010
New	Approved basic 07-109086 BP 2006 IRC Plan: 1561 Two-story Duplex with attached ga	2010
New	Two-story SFR with attached garage - 2009 IRC	2010
New	SFR, Rambler style, 3 bedroom, 2 bath home with attached two car garage	2010
New	Two-story SFR with covered breeze way Renewed 4/25/2012 (original expire date April 13, 201	2010
New	SFR - Rambler	2010
New	requested 30 day extension to obtain final insepction (original expired date 1/23/12 dm) 24 x 4	2010
New	Building permit for detached accessory apartment, 450 sqft living space	2010
New	Two-story SFR with attached garage, covered porch, and carport - 2006 IRC	2010
New	2147 sf SFR with 1851sf finished daylight basement and 970 sf attic storage 2009 IRC	2010
New	Detached Garage on main floor with bathroom. 2nd floor bonus room w/ bar area and bathroom	2010
New	Two-story SFR with attached garage - 2006 IRC	2010
New	3 story SFR w/ attachcd garage. Existing SFR to be removed and new SFR placed in same foot pi	2010
New	SFR, Two story with attached 2-car garage	2010
New	Rambler style sfr w/attached garage	2010
New	Manufactured Home, 2010 Double wide Palm Harbor, 27 x 48	2010
New	840 sf detached accessory apartment with 1020 sf garage - 2009 IRC	2010
New	Rambler with covererd porch and attached garage (4 bedrooms, 2 bath)	2010
New	Two Story SFR withAttached Garage	2010

Accessory Dwelling Units

Index # - File Name: 1.0022 - Single Family Dwellings Data\_Snohomish County.pdf

New	Two-story SFR with attached garage - 2006 IRC	2010
New	FIRE DESTROYED HOME, rebuild new two story style home in same footprint as old	2010
New	2111 sf rambler with attached garage - 2006 IRC	2010
New	SFR, rambler style with attached 2-car garage	2010
New	480 sq ft detached accessory apartment with 240 sq ft covered porch.	2010
New	SFR, rambler with attached 2 car garage	2010
New	SFR, rambler style with attached 2 car garage	2010
New	requested 30 day grace period 11/8/13 dm Two Story SFR with Attached Garage	2010
New	836 sq ft detached Accessory Apartment	2010
New	Two story residence with attached garage	2010
New	Manufactured Home, 2006 double wide, Palm Harbor	2010
New	requested 30 extension to obtain final inspection dm 11/10/11 Detached accessory apartmen	2010
New	828 sf SFR with 504 sf unfinished storage area and 1782 sf garage - 2006 IRC	2010
New	Cabana 1280 sf	2010
New	Two-story SFR with attached garage -2006 IRC	2010
New	Bedroom, bathroom, ADA access ramp and wrap around deck	2010
New	(Sept 9/14/12) 2-Story SFR w/attached garage *plans have been scanned*	2010
New	Two-story SFR	2010
New	requested 30 day grace period (3/22/12) Proposed 2480 square feet single family residence w/	2010
New	SFR Rambler	2010
New	4/27/12 REQUESTED 30 DAY EXTENSION ss Placement of a 1981 double wide mobile	2010
New	Two-story residence with attached garage	2010
New	SFR, 2 car garage with residence on 2nd floor, 1 bedroom, 2 bath	2010
New	Manufactured home, 1991 Skyline	2010
New	Approved basic 10-106847 BP 2009 IRC Plan# 1883 40# 2-story sfr w/attached ga	2011
New	41 x 60 2011 Skyline	2011
New	2111 sf rambler with attached garage - 2009 IRC Engineered by Michael Mitchell, P.E. 20775	2011
New	Building permit for detached accessory apartment	2011
New	SFR - 2 story with attached 3 car garage	2011
New	SFR, two story with attached 2-car garage	2011
New	Manufactured Home, 2010 Palm Harbor, double wide, 27 x 48	2011
New	Two story SFR with unfinished basement and attached garage - 2009 IRC	2011
New	27 x 56 1992 Redman with 23 x 29 pod	2011
New	SFR (garage with living space on 2nd floor)	2011
New	SFR Two Story (1,225 sf 1st floor; 1,105 sf 2nd floor; 624 sf deck; 196 sf covered deck/porch; 22.	2011
New	Two story home with attached two car garage & covered porch (2 bedrooms, 3 bath)	2011
New	Rambler w/daylight basement w/attached garage	2011
New	5478 sq ft single family residence with attached 3205 sq ft garage. Reference 10-104858-GP fc	2011
New	Reversed Expired Staus to allow for a final inspection 4/30/13 EXPIRED WITHOUT COUNTY APP	2011
New	Has requested to use the 30 grace period to get final inspection dm 3/12/13 1248 sf rambler -	2011
New	SFR, rambler with attached 3 car garage (Existing home to be demo d as part of this proposal)	2011
New	Two-story residence	2011
New	40 x 70 1998 Palm Harbour	2011
New	2-story sfr no garage	2011
New	SFR, rambler with attached 3 car garage & covered porch (4 bedrooms) Engineered by Andrew	2011
New	One-story SFR with attached garage - 2009 IRC	2011
New	Detached Accessory Apartment	2011

Accessory Dwelling Units

Index # - File Name: 1.0022 - Single Family Dwellings Data\_Snohomish County.pdf

New	Two-story SFR - 2009 IRC	2011
New	3045 sf SFR with attached garage - 2009 IRC	2011
New	extended until Oct 12th for final inspection (9/1/12 org expire date) 9/24/12 dm SFR, 2 bedroo	2011
New	2 story single family - 2006 IRC	2011
New	Manufactured home as primary residence, 2011 Doublewide Marlette, 30 x 66	2011
New	Two-story residence with bonus room over attached garage - 2009 IRC	2011
New	SFR - rambler style home with breezeway and garage, 3 bedrooms	2011
New	2193 sf rambler-style sfr with 885 sf attached garage - 2009 IRC	2011
New	2315 sf rambler with 800 sf attached garage - 2009 IRC	2011
New	SFR, Two story style home with attached 2 car garage	2011
New	Approved basic 10-106988 BP 2009 IRC Plan# 2448 2-story sfr w/attached garage	2011
New	600 sf detached accessory apartment with 360 sf covered porch	2011
New		2011
New	Duplex, two story with attached garages	2011
New	Rambler style w/ unfinished basement , carport, and covered deck	2011
New	Split level sfr w/attached	2011
New	Approved basic 11-103836 BP 2009 IRC Plan# 2178 2-story sfr w/attached garage	2011
New	Approved basic 11-103836 BP 2009 IRC Plan# 2178 2-story sfr w/attached garage	2011
New	Two Story SFR SFR with Finished Basement and Attached Garage	2011
New	Two-story SFR with attached garage - 2009 IRC Engineered by Michael Mitchell, P.E. 20775	2011
New	Approved basic 10-109489 BP 2009 IRC Plan# 1533-25# 2-story sfr w/attache	2011
New	Two-story SFR - 2009 IRC	2011
New	Garage, detached, 2 story, private storage on main floor with office, bathroom and laundry on 2	2011
New	Approved basic 11-100307 BP 2009 IRC Plan# Blakely B-3 car 2-story sfr w/attache	2011
New	Split level SFR - 2009 IRC	2011
New	Two-story SFR with attached garage - 2009 IRC	2011
New	1320 sf ramber-style SFR - 2009 IRC	2011
New	SFR - two story with attached 3-car garage & covered porch	2011
New	Approved basic 10-108816 BP 2009 IRC Plan# 1561 2-story duplex w/attache	2011
New	Rambler style sfr w/attached garage. NSF check - Accept only cash, cashier s check, credit card,	2011
New	SFR, 2-story with attached 3-car garage	2011
New	2-story sfr no garage	2011
New	Manufactured home, 1990 single wide Cozy, 14 x 66	2011
New	Two-story SFR with attached garage - 2009 IRC	2011
New	Mobile home, double wide, 1972 (per owner been existing for a while, no record of permit for t	2011
New	SFR - Two story with attached 2 car garage (3 bedrooms)	2011
New	Two-story SFR with attached garage - 2009 IRC	2011
New	Two-story SFR with attached garage - 2009 IRC CASP #201104040084	2011
New	770 sf detached accessory apartment over 1226 sf garage - 2009 IRC	2011
New	Building permit to construct a detached accessory apartment with 2-car garage Engineered by f	2011
New	SFR, two story style with attached 2 car garage	2011
New	Approved basic 10-108816 BP 2009 IRC Plan# 1561 2-story duplex w/attache	2011
New	Two story SFR with attached garage - 2009 IRC Engineered by Thomas J. Pitzer, P.E. 40881	2011
New	Two-story SFR with attached garage - 2009 IRC	2011
New	Two-story sfr to be constructed on foundation of residence destroyed by fire	2011
New	New double wide mobile	2011
New	Manufactured home, 2001, Skyline 28 x 44	2011

Accessory Dwelling Units

Index # - File Name: 1.0022 - Single Family Dwellings Data\_Snohomish County.pdf

New	Two-story SFR with attached garage - 2009 IRC Engineered by Wendell Reed, P.E. 30771	2011
New	1991 - 28 x 44 Marlette	2011
New	2 story sfr w/attached garage	2011
New	2 story sfr w/attached garage	2011
New	53 x 27 2010 Harbor Master	2011
New	Two-story SFR with attached garage - 2009 IRC	2011
New	Fire rebuild SFR	2011
New	new SFR built on partial foundation of abandoned duplex project	2011
New	Rambler style with carport and covered deck Engineered by Kurt Van Dittmar, R.A. 7197	2011
New	New permit to final expired MH permit.	2011
New	792 sf detached accessory apartment with 207sf heated storage area and 480 sf covered porch	2011
New	SFR with attached 2 car garage & covered porch	2011
New	Manufactured Home - 2011 double wide, Palm Harbor 27 x 48	2011
New	2700 Sq Ft Rambler	2011
New	Two story sfr with attached garage, 864 sf finished loft, and 720 sf attic storage area - 2006 IRC	2011
New	Accessory apartment with attached tractor garage - 2009 IRC	2011
New	40 x 48 2010 Homebuilders NW	2011
New	Reopend permit for a 1 time Final inspection dm 12/11/14 (org expire date was 1/5/14) Garage	2011
New	Approved basic 09-107878 BP 2006 IRC Plan# 1775 2-story sfr w/attached garage	2011
New	Pending Basic 11-100310-BP Two-story SFR - 2009 IRC Plan: 1336 EL	2011
New	1923 sf rambler with attached garage - 2009 IRC	2011
New	Manufactured Home, 2008 Fleetwood, 27 x 70	2011
New	Two story SFR with smi-finished basmeent and attached garage - 2006 IRC	2011
New	30 x 70 2011 Pacifica	2011
New	2-story sfr w/attached garage and garage space in basement	2011
New	2 story sfr w/attached garage	2011
New	Rambler style sfr w/attached garage	2011
New	2-story sfr w/attached garage	2011
New	Rambler with Attached Garage Engineered by H.N. Lehtinen, P.E. 24628	2011
New	Mobile home, single wide, 1975 Paramount, 14 x 60	2011
New	Rambler style sfr w/attached garage	2011
New	Approved basic 11-105891 BP 2009 IRC Plan# SL 1776 2-story sfr w/attached	2011
New	Approved basic 11-105884 BP 2009 IRC Plan# SL 1939 2-story sfr w/attached gar	2011
New	Approved basic 11-105884 BP 2009 IRC Plan# SL 1939 2-story sfr w/attached gar	2011
New	Approved basic 11-105891 BP 2009 IRC Plan# SL 1776 2-story sfr w/attached	2011
New	Approved basic 11-105891 BP 2009 IRC Plan# SL 1776 2-story sfr w/attached	2011
New	Approved basic 11-105891 BP 2009 IRC Plan# SL 1776 2-story sfr w/attached	2011
New	new SFR Engineered by Andrew M. Gahan, P.E. 44226	2011
New	Approved basic 11-105884 BP 2009 IRC Plan# SL 1939 2-story sfr w/attached gar	2011
New	Approved basic 11-105891 BP 2009 IRC Plan# SL 1776 2-story sfr w/attached	2011
New	Approved basic 11-105884 BP 2009 IRC Plan# SL 1939 2-story sfr w/attached gar	2011
New	Approved basic 11-105891 BP 2009 IRC Plan# SL 1776 2-story sfr w/attached	2011
New	Approved basic 11-105884 BP 2009 IRC Plan# SL 1939 2-story sfr w/attached gar	2011
New	Approved basic 11-105568 BP 2009 IRC Plan# 2280 2-story sfr w/attached garag	2011
New	2-story sfr w/attached garage (rebuild of fire destroyed dwelling) Gate Code 2389.....	2011
New	2-story sfr w/attached garage	2011
New	Rambler style sfr w/attached garage	2011

Accessory Dwelling Units

Index # - File Name: 1.0022 - Single Family Dwellings Data\_Snohomish County.pdf

New	Approved basic 11-103731 BP	2009 IRC	Plan# Parrington	2-story sfr w/attached g	2011
New	2-story sfr w/attached garage				2011
New	Approved basic 11-103729 BP	2009 IRC	Plan# Bainbridge	2-story sfr w/attached g	2011
New	2-story sfr w/attached garage				2011
New	2-story sfr w/attached garage				2011
New	Two-story SFR with attached garage - 2009 IRC				2011
New	2-story sfr w/attached garage				2011
New	2-story sfr w/attached garage				2011
New	2-story sfr w/attached garage				2011
New	Approved basic 10-109195 BP	2009 IRC	Plan# 1834 E	2-story sfr w/attached garage	2011
New	requested 30 day period 7/25/12 dm 2-story sfr w/attached garage				2011
New	Approved basic 10-106263 BP	2009 IRC	Plan# 2023 VT	2-story sfr w/attached gara	2011
New	Approved basic 10-106261 BP	2009 IRC	Plan# 1670 VT	2-story sfr w/attached gara	2011
New	Approved basic 10-106263 BP	2009 IRC	Plan# 2023 VT	2-story sfr w/attached gara	2011
New	Approved basic 10-106263 BP	2009 IRC	Plan# 2023 VT	2-story sfr w/attached gara	2011
New	Approved basic 10-106263 BP	2009 IRC	Plan# 2023 VT	2-story sfr w/attached gara	2011
New	Approved basic 10-106263 BP	2009 IRC	Plan# 2023 VT	2-story sfr w/attached gara	2011
New	Approved basic 10-106262 BP	2009 IRC	Plan# 1987 VT	2-story sfr w/attached garage	2011
New	Revised 05-20-2011 jrlind	Approved basic 10-106263 BP	2009 IRC	Plan# 2023 VT	2
New	Revised 05-20-2011 jrlind	Approved basic 10-106262 BP	2009 IRC	Plan# 1987 VT	2011
New	Approved basic 10-103501 BP	2009 IRC	Plan# 3012-B	2-story sfr w/attached gar	2011
New	Approved basic 10-103496 BP	2009 IRC	Plan# 3570-D	2-story sfr w/attached g	2011
New	Approved basic 10-103502 BP	2009 IRC	Plan# 3012-A	2-story sfr w/attached ga	2011
New	Approved basic 10-103499 BP	2009 IRC	Plan# 3015-B/C	2-story sfr w/attached g	2011
New	Approved basic 10-103505 BP	2009 IRC	Plan# 2420-B	2-story sfr w/attached	2011
New	Approved basic 10-103501 BP	2009 IRC	Plan# 3012-B	2-story sfr w/attached gar	2011
New	Conversion of existing residence in shop to guest house				2011
New	2-story sfr w/attached garage				2011
New	2-story sfr w/attached garage				2011
New	Rambler style sfr w/attached garage				2011
New	Approved basic 11-105566 BP	2009 IRC	Plan# 2420	2-story sfr w/attached garag	2011
New	Two Story SFR with Attached Garage				2011
New	2-story sfr w/attached garage				2011
New	Two-story SFR with attached garage - 2009 IRC				2011
New	Approved basic 11-105567 BP	2009 IRC	Plan# 2564	2-story sfr w/attached gara	2011
New	Approved basic 10-106997 BP	2009 IRC	Plan# Newman A	2-story sfr w/attache	2011
New	Approved basic 10-107477 BP	2009 IRC	Plan# Dayton A	2-story sfr w/attached gara	2011
New	Approved basic 10-106958 BP	2009 IRC	Plan# Rainier B	2-story sfr w/attached gar	2011
New	Approved basic 10-109011 BP	2009 IRC	Plan# Mansfield A	2-story sfr w/attache	2011
New	Approved basic 10-108454 BP	2009 IRC	Plan# Hazelwood-B	2-story sfr w/attache	2011
New	Approved basic 10-109010 BP	2009 IRC	Plan# Campbell A	2-story sfr w/attached g	2011
New	Approved basic 10-109014 BP	2009 IRC	Plan# Jefferson A	2-story sfr w/attached	2011
New	Approved basic 10-106962 BP	2009 IRC	Plan # Adams A	2-story sfr w/attached g	2011
New	Approved basic 10-105529 BP	2009 IRC	Plan# Baker A	2-story sfr w/attached gar	2011
New	Two-story SFR with attached garage - 2006 IRC				2011
New	2-story sfr w/attached garage				2011
New	Rambler style sfr w/attached garage				2011



Accessory Dwelling Units

Index # - File Name: 1.0022 - Single Family Dwellings Data\_Snohomish County.pdf

New	SFR - two story style with attached 2-car garage and covered porch				2011
New	Rambler style sfr w/attached garage				2011
New	Rambler style sfr w/attached garage				2011
New	2-story sfr w/attached garage				2011
New	Two-story SFR with attached garage - 2009 IRC Engineered by Steven Miller, P.E. 21255				2011
New	Two-story SFR with attached garage and unfinished storage area above garage - 2009 IRC				2011
New	2-story sfr w/attached garage				2011
New	Approved basic 11-100621 BP	2009 IRC	Plan# 1861-3 car	2-story sfr w/attached g	2011
New	Approved basic 10-109566 BP	2009 IRC	Plan# 2180-40-8	2-story sfr w/attach	2011
New	Approved basic 10-109377 BP	2009 IRC	Plan# 2569-40-8	2-story sfr w/attache	2011
New	Approved basic 10-109376 BP	2009 IRC	Plan# 2230-50-8	2-story sfr w/attached ga	2011
New	Approved basic 10-109378 BP	2009 IRC	Plan# 2726-49-8	2-story sfr w/attach	2011
New	Approved basic 10-109375 BP	2009 IRC	Plan# 2006-40-8	2-story sfr w/attached g	2011
New	SFR, Two story style home with wrap around covered porch & attached two car garage				2011
New	Approved basic 10-109026 BP	2009 IRC	Plan# 2280-02AB	2-story sfr w/attached g	2011
New	Approved basic 10-109025 BP	2009 IRC	Plan# 2384-02AB	2-story sfr w/attache	2011
New	Approved Basic 07-112055-BP	2006 IRC	Plan # AG2100-02-B	2-Story SFR w/ ati	2011
New	2-story sfr w/attached garage				2011
New	Approved basic 10-103507 BP	2009 IRC	Plan# 2420-A	2-story sfr w/attached gar	2011
New	Approved basic 10-103497 BP	2009 IRC	Plan# 3570-E	2-story sfr w/attached g	2011
New	Approved basic 10-103496 BP	2009 IRC	Plan# 3570-D	2-story sfr w/attached g	2011
New	Approved basic 10-103505 BP	2009 IRC	Plan# 2420-B	2-story sfr w/attached	2011
New	Approved basic 10-103501 BP	2009 IRC	Plan# 3012-B	2-story sfr w/attached gar	2011
New	Approved basic 10-103507 BP	2009 IRC	Plan# 2420-A	2-story sfr w/attached gar	2011
New	Approved basic 10-103502 BP	2009 IRC	Plan# 3012-A	2-story sfr w/attached ga	2011
New	Approved basic 10-103505 BP	2009 IRC	Plan# 2420-B	2-story sfr w/attached	2011
New	Approved basic 10-103499 BP	2009 IRC	Plan# 3015-B/C	2-story sfr w/attached g	2011
New	2-story sfr w/attached garage				2011
New	2-story sfr w/attached garage				2011
New	2-story sfr w/attached garage				2011
New	2-story sfr w/attached garage				2011
New	2-story sfr w/attached garage				2011
New	2-story sfr w/attached garage				2011
New	2-story sfr w/attached garage				2011
New	2-story sfr w/attached garage				2011
New	2-story sfr w/attached garage				2011
New	Approved basic 10-106155 BP	2009 IRC	Plan# 1723 A	2-story sfr w/attached gara	2011
New	Approved basic 10-106153 BP	2009 IRC	Plan# 1935 A	2-story sfr w/attached garag	2011
New	2-story sfr w/attached garage				2011
New	2-story sfr w/attached garage				2011
New	Approved basic 11-100890 BP	2009 IRC	Plan# 1841	2-story sfr w/attached gara	2011
New	Approved basic 11-100890 BP	2009 IRC	Plan# 1841	2-story sfr w/attached gara	2011
New	Approved basic 10-106155 BP	2009 IRC	Plan# 1723 A	2-story sfr w/attached gara	2011
New	Approved basic 11-100890 BP	2009 IRC	Plan# 1841	2-story sfr w/attached gara	2011
New	Two-story SFR with attached garage - 2009 IRC				2011
New	2-story sfr w/attached garage				2011
New	2-story sfr w/attached garage				2011

Accessory Dwelling Units

Index # - File Name: 1.0022 - Single Family Dwellings Data\_Snohomish County.pdf

New	Approved basic 11-107174 BP	2009 IRC	Plan# 1185-6	2-story sfr w/attached gar	2011
New	Building A unit 1				2011
New	Two-story SFR with attached garage - 2009 IRC	Engineered by Todd F. Borseth, R.A. 7428			2011
New	Approved basic 10-107469 BP	2009 IRC	Plan# 3036A-09	2-story sfr w/attached g	2011
New	Approved basic 10-108198 BP	2009 IRC	Plan# 2440 A-09	2-story sfr w/attached gar	2011
New	Approved basic 10-100210 BP	2009 IRC	Plan# 2440B-09	2-story sfr w/attached	2011
New	Approved basic 10-106170 BP	2009 IRC	Plan# 1601-02A-09	2-story sfr w/attache	2011
New	SFR - two story with attached 3-car garage & covered porch	Engineered by Ronald V Skinner, P.			2011
New	Approved basic 10-107801 BP	2009 IRC	Plan# 3117C-09	2-story sfr w/attache	2011
New	Approved basic 10-100210 BP	2009 IRC	Plan# 2440B-09	2-story sfr w/attached	2011
New	Approved basic 10-107094 BP	2009 IRC	Plan# 2734A-09	2-story sfr w/attached ga	2011
New	Approved basic 10-106613 BP	2009 IRC	Plan# 2610AB	2-story sfr w/attached	2011
New	Approved basic 10-107469 BP	2009 IRC	Plan# 3036A-09	2-story sfr w/attached g	2011
New	Approved basic 10-108198 BP	2009 IRC	Plan# 2440 A-09	2-story sfr w/attached gar	2011
New	Approved basic 11-108101 BP	2009 IRC	Plan# 1896	2-story sfr w/attached gara	2011
New	Approved basic 11-108101 BP	2009 IRC	Plan# 1896	2-story sfr w/attached gara	2011
New	Approved basic 11-103116 BP	2009 IRC	Plan# 2023	2-story sfr w/attached gara	2011
New	SFR - Two story style home with 2-car garage (3 bedrooms)				2011
New	Approved basic 11-103116 BP	2009 IRC	Plan# 2023	2-story sfr w/attached gara	2011
New	Approved basic 11-103116 BP	2009 IRC	Plan# 2023	2-story sfr w/attached gara	2011
New	Approved basic 10-108198 BP	2009 IRC	Plan# 2440 AB-09	2-story sfr w/attached ga	2011
New	Approved basic 10-108198 BP	2009 IRC	Plan# 2440 AB-09	2-story sfr w/attached ga	2011
New	Approved basic 10-108198 BP	2009 IRC	Plan# 2440 AB-09	2-story sfr w/attached ga	2011
New	Approved basic 11-109142 BP	2009 IRC	Plan# Pratt 2011	2-story sfr w/attach	2011
New	Pending basic 11-109145 BP	2009 IRC	Plan# Chambord 2260	2-story sfr w/attached g	2011
New	Approved basic 11-109147 BP	2009 IRC	Plan# Brookside 2075	2-story sfr w/att	2011
New	Approved basic 11-109147 BP	2009 IRC	Plan# Brookside 2075	2-story sfr w/at	2011
New	Approved basic 11-109142 BP	2009 IRC	Plan# Pratt 2011	2-story sfr w/attach	2011
New	Approved basic 11-100554 BP	2009 IRC	Plan# 2763-03AB	2-story sfr w/attached ga	2011
New	Approved basic 11-100555 BP	2009 IRC	Plan# 3310-03AB	2-story sfr w/attached gar	2011
New	Approved basic 10-106689 BP	2009 IRC	Plan# Jupiter	Rambler w/attached garage	2011
New	Approved basic 11-101566 BP	2009 IRC	Plan# Juno A	Rambler w/attached garage	2011
New	Approved basic 11-101566 BP	2009 IRC	Plan# Juno A	Rambler w/attached garage	2011
New	Approved basic 10-106693 BP	2009 IRC	Plan# Julia	2-story sfr w/attached garage	2011
New	Approved basic 10-106689 BP	2009 IRC	Plan# Jupiter	Rambler w/attached garage	2011
New	Approved basic 10-106693 BP	2009 IRC	Plan# Julia	2-story sfr w/attached garage	2011
New	Approved basic 10-106689 BP	2009 IRC	Plan# Jupiter	Rambler w/attached garage	2011
New	Approved Basic 08-109727-BP	Plan No. 3815-B	2006 IRC	2 story SFR w/ attached garage	2011
New	Approved Basic 08-109069-BP	Plan No. 3824-B	2006 IRC	2 story SFR w/ attached garage	2011
New	Approved Basic 08-109724-BP	Plan No. 3813-AB	2006 IRC	2 story SFR w/ attached garage	2011
New	Approved Basic 08-109066-BP	Plan No. 3823-A	2006 IRC	2nd story SFR w/ attached garage	2011
New	Approved Basic 08-111195-BP	Plan No. 3804-AB	2006 IRC	2 story SFR w/ attached g	2011
New	Approved Basic 08-109068-BP	Plan No. 3824-A	2006 IRC	2 story SFR w/ attached garage	2011
New	Approved Basic 08-109725-BP	Plan No. 3814-AB	2006 IRC	2 story SFR w/ attached garag	2011
New	Approved Basic 08-109062-BP	Plan No 3821-A	2006 IRC	2 story SFR w/ attached garage	2011
New	Approved Basic 08-109724-BP	Plan No. 3813-AB	2006 IRC	2 story SFR w/ attached garage	2011
New	Approved Basic 08-109068-BP	Plan No. 3824-A	2006 IRC	2 story SFR w/ attached garage	2011

Accessory Dwelling Units

Index # - File Name: 1.0022 - Single Family Dwellings Data\_Snohomish County.pdf

New	Approved Basic 08-109727-BP	Plan No. 3815-B	2006 IRC	2 story SFR w/ attached garage	2011
New	Revision submitted 05-26-2011 jrlind	Approved basic 10-106095 BP	2009 IRC	Plan # 37	2011
New	Approved Basic 08-109724-BP	Plan No. 3813-AB	2006 IRC	2 story SFR w/ attached garage	2011
New	Approved Basic 08-109064-BP	Plan No. 3822-A	2006 IRC	2 story SFR w/ attached garage	2011
New	Approved Basic 08-109725-BP	Plan No. 3814-AB	2006 IRC	2 story SFR w/ attached garag	2011
New	Approved Basic 08-109067-BP	Plan No. 3823-B	2006 IRC	2 story SFR w/ attached garage	2011
New	Approved Basic 08-109724-BP	Plan No. 3813-AB	2006 IRC	2 story SFR w/ attached garage	2011
New	Approved Basic 08-109726-BP	Plan No. 3815-A	2006 IRC	2 story SFR w/ attached garage	2011
New	Approved Basic 08-109069-BP	Plan No. 3824-B	2006 IRC	2 story SFR w/ attached garage	2011
New	Approved Basic 08-109725-BP	Plan No. 3814-AB	2006 IRC	2 story SFR w/ attached garag	2011
New	Approved Basic 08-109724-BP	Plan No. 3813-AB	2006 IRC	2 story SFR w/ attached garage	2011
New	Approved basic 07-108257 BP	2006 IRC	Plan# 3026-A	2-story sfr w/attached ga	2011
New	Approved Basic 08-109066-BP	Plan No. 3823-A	2006 IRC	2nd story SFR w/ attached garag	2011
New	Approved Basic 08-109063-BP	Plan No. 3821-B	2006 IRC	2 story SFR w/ attached garage	2011
New	Approved Basic 08-109064-BP	Plan No. 3822-A	2006 IRC	2 story SFR w/ attached garage	2011
New	Approved Basic 08-109068-BP	Plan No. 3824-A	2006 IRC	2 story SFR w/ attached garage	2011
New	Approved Basic 08-109067-BP	Plan No. 3823-B	2006 IRC	2 story SFR w/ attached garage	2011
New	Approved Basic 08-109726-BP	Plan No. 3815-A	2006 IRC	2 story SFR w/ attached garage	2011
New	SFR - two story with attached 2-car garage & covered porch				2011
New	Approved basic 11-102895 BP	2009 IRC	Plan# 3727-B	2-story sfr w/attached gara	2011
New	Approved basic 07-108259 BP	2006 IRC	Plan# 3026-B	2-story sfr w/attached ga	2011
New	Approved basic 07-111283 BP	2006 IRC	Plan# 3027Den-C	2-story sfr w/ den & attached	2011
New	Approved basic 07-108274 BP	2006 IRC	Plan# 4010Den-C	2-story sfr w/ den & attached g	2011
New	Approved basic 07-108259 BP	2006 IRC	Plan# 3026-B	2-story sfr w/attached ga	2011
New	Revision submitted 05-26-2011 jrlind	Approved basic 10-106094 BP	2009 IRC	Plan# 37	2011
New	Approved basic 10-107933 BP	2009 IRC	Plan# 2306	2-story sfr w/attached ga	2011
New	Approved basic 10-107934 BP	2009 IRC	Plan#2160	2-story sfr w/attache	2011
New	Approved basic 10-107933 BP	2009 IRC	Plan# 2306	2-story sfr w/attached ga	2011
New	Approved basic 10-107934 BP	2009 IRC	Plan#2160	2-story sfr w/attache	2011
New	Approved basic 10-108132 BP	2009 IRC	Plan# 2588	2-story sfr w/attached garage	2011
New	2-story sfr w/attached garage				2011
New	2-story sfr w/attached garage				2011
New	Approved basic 10-107670 BP	2009 IRC	Plan# 1238 40#	2-story sfr w/attached	2011
New	Approved Basic 08-109725-BP	Plan No. 3814-AB	2006 IRC	2 story SFR w/ attached garag	2011
New	Approved Basic 08-109726-BP	Plan No. 3815-A	2006 IRC	2 story SFR w/ attached garage	2011
New	Approved Basic 08-109066-BP	Plan No. 3823-A	2006 IRC	2nd story SFR w/ attached garag	2011
New	Approved Basic 08-109726-BP	Plan No. 3815-A	2006 IRC	2 story SFR w/ attached garage	2011
New	Approved Basic 08-109724-BP	Plan No. 3813-AB	2006 IRC	2 story SFR w/ attached garage	2011
New	2-story sfr w/attached garage				2011
New	Approved basic 10-107934 BP	2009 IRC	Plan#	2-story sfr w/attached gara	2011
New	Approved basic 10-108132 BP	2009 IRC	Plan# 2588	2-story sfr w/attached garage	2011
New	Approved basic 10-107933 BP	2009 IRC	Plan# 2306	2-story sfr w/attached ga	2011
New	Two-story SFR with attached garage - 2009 IRC				2011
New	Two-story SFR with attached garage - 2009 IRC				2011
New	install 27 x 52 MH in foot print of approved 07-110219-MH 10/11/0211: SEE INSPECTION PROC				2011
New	Approved Basic 07-113012	Builder Plan No 2722	2006 IRC	One story SFR w/	2011
New	Rambler style sfr w/attached garage				2011

Accessory Dwelling Units

Index # - File Name: 1.0022 - Single Family Dwellings Data\_Snohomish County.pdf

New	Approved basic 11-104990 BP	2009 IRC	Plan# 2723	2-story sfr w/attached garag	2011
New	SFR, rambler style home with attached 2-car garage				2011
New	2-story sfr w/attached garage				2011
New	Approved basic 09-105969 BP	2006 IRC	Plan# 1914	2-story sfr w/attached	2011
New	Approved basic 09-105969 BP	2006 IRC	Plan# 1914	2-story sfr w/attached	2011
New	Approved basic 07-111255 BP	2006 IRC	Plan# 1785	2-story sfr w/attached gar	2011
New	Approved basic 11-107388 BP	2009 IRC	Plan# 2202	2-story sfr w/attached garag	2011
New	Approved basic 11-107388 BP	2009 IRC	Plan# 2202	2-story sfr w/attached garag	2011
New	Approved basic 11-107388 BP	2009 IRC	Plan# 2202	2-story sfr w/attached garag	2011
New	2-story sfr w/attached garage				2011
New	Approved basic 10-108986 BP	2009 IRC	Plan# 2183	2-story sfr w/attached gara	2011
New	Approved basic 10-108556 BP	2009 IRC	Plan# 2157	2-story sfr w/attached garag	2011
New	Approved basic 10-108986 BP	2009 IRC	Plan# 2183	2-story sfr w/attached garag	2011
New	Approved basic 10-108556 BP	2009 IRC	Plan# 2157	2-story sfr w/attached garag	2011
New	Approved basic 10-108986 BP	2009 IRC	Plan# 2183	2-story sfr w/attached garag	2011
New	Approved basic 10-108556 BP	2009 IRC	Plan# 2157	2-story sfr w/attached garag	2011
New	Approved basic 10-108986 BP	2009 IRC	Plan# 2183	2-story sfr w/attached gara	2011
New	Approved basic 10-108559 BP	2009 IRC	Plan# 2464	2-story sfr w/attached garage	2011
New	Approved basic 10-108558 BP	2009 IRC	Plan# 2258	2-story sfr w/attached gara	2011
New	Approved basic 11-100230 BP	2009 IRC	Plan# 1888SL	2-story sfr w/attache	2011
New	Approved basic 10-108986 BP	2009 IRC	Plan# 2183	2-story sfr w/attached garag	2011
New	Approved basic 10-108559 BP	2009 IRC	Plan# 2464	2-story sfr w/attached garage	2011
New	Approved basic 10-108556 BP	2009 IRC	Plan# 2157	2-story sfr w/attached garag	2011
New	Approved basic 10-108986 BP	2009 IRC	Plan# 2183	2-story sfr w/attached garag	2011
New	Approved basic 10-108559 BP	2009 IRC	Plan# 2464	2-story sfr w/attached garage	2011
New	Approved basic 10-108556 BP	2009 IRC	Plan# 2157	2-story sfr w/attached garag	2011
New	Approved basic 10-109160 BP	2009 IRC	Plan# 1888	2-story sfr w/attached garage	2011
New	Approved basic 10-108986 BP	2009 IRC	Plan# 2183	2-story sfr w/attached garag	2011
New	Approved basic 10-108986 BP	2009 IRC	Plan# 2183	2-story sfr w/attached gara	2011
New	Approved basic 10-108984 BP	2009 IRC	Plan# 1848	2-story sfr w/attached ga	2011
New	Approved basic 10-108558 BP	2009 IRC	Plan# 2258	2-story sfr w/attached gara	2011
New	Approved basic 10-108559 BP	2009 IRC	Plan# 2464	2-story sfr w/attached garage	2011
New	Approved basic 10-108556 BP	2009 IRC	Plan# 2157	2-story sfr w/attached garag	2011
New	Approved basic 11-100230 BP	2009 IRC	Plan# 1888SL	2-story sfr w/attache	2011
New	Rambler style sfr w/attached garage				2011
New	SFR, Two story home with atatched 3 car garage, bonus room and covered porch				2011
New	Approved basic 11-104699 BP	2009 IRC	Plan# 2408-02A	3-story sfr w/attached g	2011
New	Approved basic 11-105904 BP	2009 IRC	Plan# 2007-02AB	2-story sfr w/attache	2011
New	Approved Basic 10-107346 BP	2009 IRC	Plan# 2120-02A	2-story sfr w/attached	2011
New	Approved basic 11-103199 BP	2009 IRC	Plan# 2149	2-story sfr wattached ga	2011
New	Approved basic 11-105904 BP	2009 IRC	Plan# 2007-02AB	2-story sfr w/attache	2011
New	Approved basic 11-102290 BP	2009 IRC	Plan# 2268-02AB	2-story sfr w/attache	2011
New	Approved basic 10-104914 BP	2009 IRC	Plan# 2112	2-story sfr w/attached gar	2011
New	Approved basic 10-103064 BP	2006 IRC	Plan# 2158-02AB	2-story sfr w/attached g	2011
New	Approved basic 10-103064 BP	2006 IRC	Plan# 2158-02AB	2-story sfr w/attached g	2011
New	Approved basic 10-103064 BP	2006 IRC	Plan# 2158-02AB	2-story sfr w/attached g	2011
New	Approved basic 11-108600 BP	2009 IRC	Plan# 2158-02AB	2-story sfr w/attached g	2011

Accessory Dwelling Units

Index # - File Name: 1.0022 - Single Family Dwellings Data\_Snohomish County.pdf

New	Approved basic 11-105866 BP	2009 IRC	Plan# 2040	2-story sfr w/attached garage	2011
New	Approved basic 11-105863 BP	2009 IRC	Plan# 2298	2-story sfr w/attached garage	2011
New	Approved basic 11-105866 BP	2009 IRC	Plan# 2040	2-story sfr w/attached garage	2011
New	Approved basic 11-105863 BP	2009 IRC	Plan# 2298	2-story sfr w/attached garage	2011
New	Approved basic 10-108760 BP	2009 IRC	Plan# 4050-49-9	2-story sfr w/attached garage	2011
New	Approved basic 10-108756 BP	2009 IRC	Plan# 3531-40-8	2-story sfr w/attached garage	2011
New	Approved basic 10-108756 BP	2009 IRC	Plan# 3531-40-8	2-story sfr w/attached garage	2011
New	Approved basic 10-108760 BP	2009 IRC	Plan# 4050-49-9	2-story sfr w/attached garage	2011
New	Approved basic 09-102879 BP	2006 IRC	Plan# 627	2-story sfr w/attached garage	2011
New	Approved basic 09-102879 BP	2006 IRC	Plan# 627	2-story sfr w/attached garage	2011
New	Approved basic 09-102879 BP	2006 IRC	Plan# 627	2-story sfr w/attached garage	2011
New	Approved basic 09-102879 BP	2006 IRC	Plan# 627	2-story sfr w/attached garage	2011
New	Approved basic 09-102881 BP	2006 IRC	Plan# 628	2-story sfr w/attached garage	2011
New	2-story sfr w/attached garage				2011
New	SFR, two story sfr w/ attached garage				2011
New	SFR, two-story sfr w/ attached garage				2011
New	Approved basic 09-102881 BP	2006 IRC	Plan# 628	2-story sfr w/attached garage	2011
New	Approved basic 09-102881 BP	2006 IRC	Plan# 628	2-story sfr w/attached garage	2011
New	Approved basic 09-102881 BP	2006 IRC	Plan# 628	2-story sfr w/attached garage	2011
New	Approved basic 09-102881 BP	2006 IRC	Plan# 628	2-story sfr w/attached garage	2011
New	Approved basic 10-106155 BP	2009 IRC	Plan# 1723 A	2-story sfr w/attached garage	2011
New	Approved Basic 10-102727BP	2006 IRC	Plan: 1935-M Elev. A / B	Two story sfr with attached garage	2011
New	Approved Basic 10-102725BP	2006 IRC	Plan: 1892M Elevations A&B	2-story SFR w/attached garage	2011
New	Approved Basic 10-102912BP	Two-story SFR with attached garage	2006 IRC	Plan: 22	2011
New	Approved Basic 10-102727BP	2006 IRC	Plan: 1935-M Elev. A / B	Two story sfr with attached garage	2011
New	Approved basic 10-106155 BP	2009 IRC	Plan# 1723 A	2-story sfr w/attached garage	2011
New	Approved basic 10-106148 BP	2009 IRC	Plan# 1892 B	2-story sfr w/attached garage	2011
New	Approved basic 10-106155 BP	2009 IRC	Plan# 1723 A	2-story sfr w/attached garage	2011
New	Approved Basic 10-102912BP	Two-story SFR with attached garage	2006 IRC	Plan: 22	2011
New	Approved basic 10-106155 BP	2009 IRC	Plan# 1723 A	2-story sfr w/attached garage	2011
New	Approved basic 10-106155 BP	2009 IRC	Plan# 1723 A	2-story sfr w/attached garage	2011
New	Approved basic 10-106148 BP	2009 IRC	Plan# 1892 B	2-story sfr w/attached garage	2011
New	Approved basic 10-106154 BP	2009 IRC	Plan# 1935 B	2-story sfr w/attached garage	2011
New	Approved Basic 10-102912BP	Two-story SFR with attached garage	2006 IRC	Plan: 22	2011
New	Approved basic 10-108071 BP	2009 IRC	Plan# 1472	Ramber style w/attached garage	2011
New	Approved Basic 10-102912BP	Two-story SFR with attached garage	2006 IRC	Plan: 22	2011
New	Approved basic 10-108071 BP	2009 IRC	Plan# 1472	Ramber style w/attached garage	2011
New	2-story sfr w/attached garage	2006 WA State Energy Code			2011
New	Rambler style sfr w/attached garage				2011
New	2-story sfr w/attached garage	2006 WA State Energy Code			2011
New	2-story sfr w/attached garge	2006 WA State Energy Code			2011
New	2-story sfr w/attached garage	2006 Energy Code			2011
New	Rambler style sfr w/attached garage				2011
New	2-story sfr w/attached garage	2006 WA State Energy Code			2011
New	Rambler stlye sfr w/attached garage				2011
New	2-story sfr w/attached garage				2011
New	Approved basic 10-107529	2009 IRC	Plan#2033	Mid entry sfr w/attached garage	2011



Accessory Dwelling Units

Index # - File Name: 1.0022 - Single Family Dwellings Data\_Snohomish County.pdf

New	2-story sfr w/attached garage				2011
New	2-story sfr w/attached garage				2011
New	2-story sfr w/attached garage				2011
New	2-story sfr w/attached garage				2011
New	2-story sfr w/attached garage				2011
New	2-story sfr w/attached garage				2011
New	Approved basic 11-104995 BP	2009 IRC	Plan# B720-B	2-story sfr w/attached garage	2011
New	Approved basic 11-102301 BP	2009 IRC	Plan# B725-B	2-story sfr w/attached garage	2011
New	2-story sfr w/attached garage				2011
New	Approved basic 11-104994 BP	2009 IRC	Plan# B720-A	2-story sfr w/attached garage	2011
New	Approved basic 10-106095 BP	2009 IRC	Plan # 3724-B	2-story sfr w/attached garage	2011
New	Approved basic 11-100917 BP	2009 IRC	Plan\$ 3707-A	Rambler style sfr w/attached garage	2011
New	Approved basic 10-106094 BP	2009 IRC	Plan# 3724-A	2-story sfr w/attached garage	2011
New	Approved basic 10-107036 BP	2009 IRC	Plan # 3726-B	2-story sfr w/attached garage	2011
New	Approved basic 10-106095 BP	2009 IRC	Plan # 3724-B	2-story sfr w/attached garage	2011
New	Approved basic 10-108190 BP	2009 IRC	Plan# 4710-B	2-story sfr w/attached garage	2011
New	Approved basic 11-100918 BP	2009 IRC	Plan# 3707-B	Rambler style sfr w/attached	2011
New	One-story SFR with attached garage - 2009 IRC				2011
New	Rambler style sfr w/attached garage				2011
New	Approved basic 10-105931 BP	2009 IRC	Plan# Shasta II-A	2-story sfr w/attached garage	2011
New	Approved basic 10-106962 BP	2009 IRC	Plan # Adams A	2-story sfr w/attached garage	2011
New	Approved basic 10-109014 BP	2009 IRC	Plan# Jefferson A	2-story sfr w/attached	2011
New	Approved basic 10-107478 BP	2009 IRC	Plan# Jameson A	2-story sfr w/attached garage	2011
New	Approved basic 10-109013 BP	2009 IRC	Plan# Granite A	2-story sfr w/attached garage	2011
New	Approved basic 11-109055 BP	2009 IRC	Plan# Chamberlain-A	2-story sfr w/attached	2011
New	Approved basic 11-109056 BP	2009 IRC	Plan# Chamberlain-B	2-story sfr w/attached	2011
New	Approved basic 10-106962 BP	2009 IRC	Plan # Adams A	2-story sfr w/attached garage	2011
New	2-story sfr w/attached garage				2011
New	2-story sfr w/attached garage				2011
New	Two-story SFR with unfinished basement - 2009 IRC	Engineered by Jason B. Lindquist, P.E. 4424			2011
New	2-story sfr w/attached garage				2011
New	2-story sfr w/attached garage				2011
New	Approved basic 11-102512 BP	2009 IRC	Plan# 3148 db	Rambler daylight basement	2011
New	Approved basic 10-105943 BP	2009 IRC	Plan# 3174	2-story sfr w/attached garage	2011
New	Approved basic 10-108456 BP	2009 IRC	Plan# Shasta II-B	2-story sfr w/attached	2011
New	Approved basic 10-106515 BP	2009 IRC	Plan# 2664	2-story sfr w/attached garage	2011
New	Approved basic 10-108892 BP	2009 IRC	Plan# 2131 w/bonus	Rambler w/attached	2011
New	Approved basic 09-100225 BP	2006 IRC	Plan# 2131	Rambler style sfr w/attached garage	2011
New	Approved basic 10-109491 BP	2009 IRC	Plan# 2542	2-story sfr w/attached garage	2011
New	Approved basic 11-101118 BP	2009 IRC	Plan# 2588	2-story sfr w/attached garage	2011
New	Approved basic 10-108798 BP	2009 IRC	Plan# 2067	Rambler style sfr w/attached garage	2011
New	2-story sfr w/attached garage				2011
New	2-story sfr w/attached garage				2011
New	Rambler w/unfinished basement w/attached garage				2011
New	2-story sfr w/attached garage				2011
New	2-story sfr w/attached garage				2011
New	Approved basic 11-101437 BP	2009 IRC	Plan# 2671	2-story sfr w/attached garage	2011

Accessory Dwelling Units

Index # - File Name: 1.0022 - Single Family Dwellings Data\_Snohomish County.pdf

New	2-story sfr w/attached garage					2011
New	2-story sfr w/attached garage					2011
New	Approved basic 10-109545 BP	2009 IRC	Plan# 1530	2-story sfr w/attached g		2011
New	Approved basic 10-109540 BP	2009 IRC	Plan# 1530/1540 duplex	2-story dupl		2011
New	Approved basic 10-109540 BP	2009 IRC	Plan# 1530/1540 duplex	2-story dup		2011
New	Approved basic 10-109540 BP	2009 IRC	Plan# 1530/1540 duplex	2-story dup		2011
New	2-story sfr w/attached garage					2011
New	Approved basic 10-109545 BP	2009 IRC	Plan# 1530	2-story sfr w/attached g;		2011
New	Two-story SFR with attached garage - 2009 IRC					2011
New	Approved Basic 10-106196 BP	2009 IRC	Plan # 1409	Rambler SFR w/attached 3-car g		2011
New	1665 sq ft Rambler with Attached Garage					2011
New	Approved basic 11-108692 BP	2009 IRC	Plan# 1840	Rambler w/attached garage		2011
New	One time extension granted: Application extended for 18 months. Expires August 8, 2012 Mike					2011
New	Approved basic 10-109545 BP	2009 IRC	Plan# 1530	2-story sfr w/attached g		2011
New	2-story sfr w/attached garage					2011
New	Two-story SFR - 2009 IRC					2011
New	Approved basic 11-104778 BP	2009 IRC	Plan# 1330	Rambler style sfr w/attached		2011
New	Approved basic 11-104779 BP	2009 IRC	Plan# 1468	Rambler style sfr w/attached g;		2011
New	Approved basic 10-109555 BP	2009 IRC	Plan# 2464	2-story sfr w/attached gar		2011
New	Approved basic 10-105501 BP	2009 IRC	Plan# 2186	Rambler w/attached gara		2011
New	Approved basic 10-109555 BP	2009 IRC	Plan# 2464	2-story sfr w/attached gar		2011
New	Approved basic 10-109367 BP	2009 IRC	Plan# 2453	Rambler style sfr w/attached g		2011
New	Approved basic 10-109367 BP	2009 IRC	Plan# 2453	Rambler style sfr w/attached g		2011
New	Approved basic 10-109367 BP	2009 IRC	Plan# 2453	Rambler style sfr w/attached g		2011
New	Rambler w/daylight basement w/attached garage					2011
New	2-story sfr w/attached garage					2011
New	2-story sfr w/attached garage					2011
New	2-story sfr w/attached garage					2011
New	2-story sfr w/attached garage					2011
New	Approved basic 11-105561 BP	2009 IRC	Plan# 3431-3	2-story sfr w/attached		2011
New	2-story sfr w/attached garage					2011
New	2-story sfr w/attached garage					2011
New	Approved basic 11-107680 BP	2009 IRC	Plan# 4173-3	2-story w/daylight basement w		2011
New	2-story sfr w/attached garage					2011
New	new SFR					2011
New	2-story sfr w/attached garage					2011
New	Approved basic 10-109377 BP	2009 IRC	Plan# 2569-40-8	2-story sfr w/attachei		2011
New	Approved basic 10-109377 BP	2009 IRC	Plan# 2569-40-8	2-story sfr w/attachei		2011
New	2-story sfr w/daylight basement and attached garage					2011
New	Building V unit 17					2011
New	Approved basic 11-105000 BP	2009 IRC	Plan# 2358 A	2-story sfr w/attached g		2011
New	Approved basic 11-105000 BP	2009 IRC	Plan# 2358 A	2-story sfr w/attached g		2011
New	Building O unit 62					2011
New	Building O unit 63					2011
New	Building O unit 64					2011
New	Building A unit 2					2011
New	Building A unit 3					2011



Accessory Dwelling Units

Index # - File Name: 1.0022 - Single Family Dwellings Data\_Snohomish County.pdf

New	Building A unit 4					2011
New	Building V unit 18					2011
New	Building V unit 19					2011
New	Building V unit 20					2011
New	Building P unit 82					2011
New	Building P unit 83					2011
New	Building P unit 84					2011
New	Approved basic 11-102384 RK	2009 IRC	Plan# 2100	2-story sfr w/attached g		2011
New	Approved basic 11-102384 RK	2009 IRC	Plan# 2100	2-story sfr w/attached		2011
New	2-story sfr w/attached garage					2011
New	Building O unit 61					2011
New	Building P unit 81					2011
New	2 story style sfr w/attached garage at main floor					2011
New	Approved basic 10-103189 BP	2009 IRC	Plan# Glenbrook (2)	2-story sfr w/at		2011
New	Approved basic 10-103193 BP	2009 IRC	Plan# Auburn	2-story sfr w/attached ga		2011
New	Approved basic 10-103193 BP	2009 IRC	Plan# Auburn	2-story sfr w/attached ga		2011
New	Approved Basic 11-102429BP	Two-story SFR with attached garage	2009 IRC	Plan: 223		2011
New	Approved Basic 11-102425BP	Two-story SFR with attached garage	2009 IRC	Plan: 1918		2011
New	Approved Basic 11-102429BP	Two-story SFR with attached garage	2009 IRC	Plan: 223		2011
New	Approved Basic 11-102425BP	Two-story SFR with attached garage	2009 IRC	Plan: 1918		2011
New	Approved Basic 11-102429BP	Two-story SFR with attached garage	2009 IRC	Plan: 223		2011
New	Approved Basic 11-102429BP	Two-story SFR with attached garage	2009 IRC	Plan: 223		2011
New	Approved Basic 11-102425BP	Two-story SFR with attached garage	2009 IRC	Plan: 1918		2011
New	Approved basic 11-104448 BP	2009 IRC	Plan# 2455	2-story sfr w/attached gara		2011
New	Approved basic 11-104448 BP	2009 IRC	Plan# 2455	2-story sfr w/attached gara		2011
New	Approved basic 11-104444 BP	2009 IRC	Plan# 2377	2-story sfr w/attached garage		2011
New	Approved basic 11-104444 BP	2009 IRC	Plan# 2377	2-story sfr w/attached garage		2011
New	Approved basic 11-104444 BP	2009 IRC	Plan# 2377	2-story sfr w/attached garage		2011
New	Approved basic 11-104448 BP	2009 IRC	Plan# 2455	2-story sfr w/attached gara		2011
New	Approved basic 10-103187 BP	2009 IRC	Plan# Summerlin	2-story sfr w/attached		2011
New	Revised 06-01-2011 jrlind	Approved basic 10-103190 BP	2009IRC	Plan# Brighton		2011
New	Approved basic 12-102682 BP	2009 IRC	Plan# 2390 40# Snowload	2-story sfr w/att		2011
New	Rambler style sfr w/attached garage and bonus above					2011
New	Rambler style sfr w/attached garage					2011
New	Approved basic 10-107670 BP	2009 IRC	Plan# 1238 40#	2-story sfr w/attached		2011
New	2-story sfr w/attached garage					2011
New	2-story sfr w/attached garage					2011
New	Approved basic 10-103185 BP	2009 IRC	Plan# Westport	2-story daylight w/attac		2011
New	Approved basic 10-103189 BP	2009 IRC	Plan# Glenbrook (2)	2-story sfr w/at		2011
New	Approved Basic 11-101705BP	Two story SFR with attached garage -	2009 IRC	Plan: 07:		2011
New	Approved basic 11-104444 BP	2009 IRC	Plan# 2377	2-story sfr w/attached garage		2011
New	Approved basic 11-107393 BP	2009 IRC	Plan# 2381	2-story sfr w/attached garage		2011
New	Approved basic 11-102438 BP	2009	Plan# 1894/2042	2-story sfr w/attached g		2011
New	Approved basic 11-104444 BP	2009 IRC	Plan# 2377	2-story sfr w/attached garage		2011
New	Approved basic 11-104448 BP	2009 IRC	Plan# 2455	2-story sfr w/attached gara		2011
New	Approved basic 11-102438 BP	2009	Plan# 1894/2042	2-story sfr w/attached g		2011
New	Approved basic 11-102438 BP	2009	Plan# 1894/2042	2-story sfr w/attached g		2011

Accessory Dwelling Units

Index # - File Name: 1.0022 - Single Family Dwellings Data\_Snohomish County.pdf

New	Approved basic 11-102438 BP	2009	Plan# 1894/2042	2-story sfr w/attached g	2011
New	3 story sfr w/attached garage				2011
New	Approved basic 11-102438 BP	2009	Plan# 1894/2042	2-story sfr w/attached g	2011
New	Approved basic 11-102438 BP	2009	Plan# 1894/2042	2-story sfr w/attached g	2011
New	Approved basic 10-105911 BP	2009 IRC	Plan#2140-02A-09	2-story sfr w/attached g	2011
New	Approved basic 10-106169 BP	2009 IRC	Plan#2012-02AB-09	2-story sfr w/attache	2011
New	Approved basic 10-105911 BP	2009 IRC	Plan#2140-02A-09	2-story sfr w/attached g	2011
New	Approved basic 10-106169 BP	2009 IRC	Plan#2012-02AB-09	2-story sfr w/attache	2011
New	Approved basic 10-106169 BP	2009 IRC	Plan#2012-02AB-09	2-story sfr w/attache	2011
New	Approved basic 10-106170 BP	2009 IRC	Plan# 1601-02A-09	2-story sfr w/attache	2011
New	Approved Basic Plan 10-105979 BP	2009 IRC	Plan# 2042 A/B/C-09N	2-story s	2011
New	Approved basic 10-106169 BP	2009 IRC	Plan#2012-02AB-09	2-story sfr w/attache	2011
New	Approved basic 10-107498 BP	2009 IRC	Plan# 2140C-09	2-story sfr w/attached	2011
New	Approved basic 10-105911 BP	2009 IRC	Plan#2140-02A-09	2-story sfr w/attached g	2011
New	Approved basic 10-108198 BP	2009 IRC	Plan# 2440 AB-09	2-story sfr w/attached g	2011
New	Approved basic 10-105911 BP	2009 IRC	Plan#2140-02A-09	2-story sfr w/attached g	2011
New	Approved basic 10-106169 BP	2009 IRC	Plan#2012-02AB-09	2-story sfr w/attache	2011
New	Approved basic 10-106169 BP	2009 IRC	Plan#2012-02AB-09	2-story sfr w/attache	2011
New	Approved basic 10-106170 BP	2009 IRC	Plan# 1601-02A-09	2-story sfr w/attache	2011
New	Approved basic 10-106169 BP	2009 IRC	Plan#2012-02AB-09	2-story sfr w/attache	2011
New	Approved basic 10-105911 BP	2009 IRC	Plan#2140-02A-09	2-story sfr w/attached g	2011
New	Approved basic 10-107498 BP	2009 IRC	Plan# 2140C-09	2-story sfr w/attached	2011
New	Approved basic 11-106187 BP	2009 IRC	Plan# 2214 A - 09	2-story sfr w/attache	2011
New	Approved basic 10-106169 BP	2009 IRC	Plan#2012-02AB-09	2-story sfr w/attache	2011
New	Approved basic 10-106169 BP	2009 IRC	Plan#2012-02AB-09	2-story sfr w/attache	2011
New	Approved basic 10-108379 BP	2009 IRC	Plan# 2472A - 09	2-story sfr w/attached	2011
New	Approved basic 10-106169 BP	2009 IRC	Plan#2012-02AB-09	2-story sfr w/attache	2011
New	2278 sf rambler with 858 sf attached garage -	2009 IRC			2011
New	Approved basic 10-106169 BP	2009 IRC	Plan#2012-02AB-09	2-story sfr w/attache	2011
New	Approved basic 10-106169 BP	2009 IRC	Plan#2012-02AB-09	2-story sfr w/attache	2011
New	Approved basic 10-106169 BP	2009 IRC	Plan#2012-02AB-09	2-story sfr w/attache	2011
New	Approved basic 10-105911 BP	2009 IRC	Plan#2140-02A-09	2-story sfr w/attached g	2011
New	Approved basic 10-108198 BP	2009 IRC	Plan# 2440 A-09	2-story sfr w/attached gar	2011
New	Approved basic 10-107498 BP	2009 IRC	Plan# 2140C-09	2-story sfr w/attached	2011
New	Approved basic 10-105911 BP	2009 IRC	Plan#2140-02A-09	2-story sfr w/attached g	2011
New	Approved basic 10-107498 BP	2009 IRC	Plan# 2140C-09	2-story sfr w/attached	2011
New	Approved basic 10-107821 BP	2009 IRC	Plan# 2140B-09	2-story sfr w/attach	2011
New	Approved basic 10-107498 BP	2009 IRC	Plan# 2140C-09	2-story sfr w/attached	2011
New	Approved basic 10-108198 BP	2009 IRC	Plan# 2440 A-09	2-story sfr w/attached gar	2011
New	Approved basic 10-100210 BP	2009 IRC	Plan# 2440B-09	2-story sfr w/attached	2011
New	Approved basic 10-108198 BP	2009 IRC	Plan# 2440 A-09	2-story sfr w/attached gar	2011
New	Approved basic 10-107821 BP	2009 IRC	Plan# 2140B-09	2-story sfr w/attach	2011
New	Approved basic 10-107498 BP	2009 IRC	Plan# 2140C-09	2-story sfr w/attached	2011
New	Approved basic 10-106170 BP	2009 IRC	Plan# 1601-02A-09	2-story sfr w/attache	2011
New	Approved basic 10-106169 BP	2009 IRC	Plan#2012-02AB-09	2-story sfr w/attache	2011
New	REVISED 05-10-2011 jr lind	Approved basic 11-102783 BP	2009 IRC	Plan# 2440	2011
New	Approved basic 10-100210 BP	2009 IRC	Plan# 2440B-09	2-story sfr w/attached	2011

Accessory Dwelling Units

Index # - File Name: 1.0022 - Single Family Dwellings Data\_Snohomish County.pdf

New	Approved Basic Plan 10-105979 BP	2009 IRC	Plan# 2042 A/B/C-09N	2-story s	2011
New	Approved basic 10-105911 BP	2009 IRC	Plan#2140-02A-09	2-story sfr w/attached g	2011
New	Approved Basic Plan 10-105979 BP	2009 IRC	Plan# 2042 A/B/C-09N	2-story s	2011
New	Approved basic 10-106169 BP	2009 IRC	Plan#2012-02AB-09	2-story sfr w/attache	2011
New	Approved basic 10-106169 BP	2009 IRC	Plan#2012-02AB-09	2-story sfr w/attache	2011
New	Approved basic 10-108379 BP	2009 IRC	Plan# 2472A - 09	2-story sfr w/attached	2011
New	Two-story SFR - 2009 IRC				2011
New	Approved basic 11-107951 BP	2009 IRC	Plan# 1892	2-story sfr w/attached garage	2011
New	Approved basic 11-107949 BP	2009 IRC	Plan# 1825	2-story sfr w/attached garage	2011
New	Approved basic 10-108163 BP	2009 IRC	Plan# 2547	2-story sfr w/attached garage	2011
New	Approved basic 10-108163 BP	2009 IRC	Plan# 2547	2-story sfr w/attached garage	2011
New	2-story sfr w/attached garage				2011
New	Requesting to use his 30 day grace period (org. expire date 1/15/13) dm 1/4/13 2 - story sfr w/i				2011
New	Approved basic 11-101309 BP	2009 IRC	Plan# 4047 C	2-story sfr w/attached gar	2011
New	Approved basic 11-101243 BP	2009 IRC	Plan# 4249 AC	2-story sfr w/attached garage	2011
New	Approved basic 11-101973 BP	2009 IRC	Plan# 4142 AB	2-story sfr w/attached g	2011
New	Approved basic 11-101308 BP	2009 IRC	Plan# 4047 B	2-story sfr w/attached garage	2011
New	Approved basic 11-101842 BP	2009 IRC	Plan# SL 3163 A	2-story sfr w/attached g	2011
New	Approved basic 11-101245 BP	2009 IRC	Plan# 4249 B	2-story sfr w/attached garage	2011
New	Approved basic 11-101307 BP	2009 IRC	Plan# 4047 A	2-story sfr w/attached gara	2011
New	Approved basic 11-101842 BP	2009 IRC	Plan# SL 3163 A	2-story sfr w/attached g	2011
New	Approved basic 11-101843 BP	2009 IRC	Plan# 4249 C	2-story sfr w/attachedg	2011
New	Approved basic 11-101309 BP	2009 IRC	Plan# 4047 C	2-story sfr w/attached gara	2011
New	Approved basic 11-101245 BP	2009 IRC	Plan# 4249 B	2-story sfr w/attached garage	2011
New	Approved basic 11-101307 BP	2009 IRC	Plan# 4047 A	2-story sfr w/attached gara	2011
New	2016 sf rambler with attached garage - 2009 IRC				2011
New	Approved basic 10-107739 BP	2009 IRC	Plan# 446	2-story sfr w/attached gar	2011
New	Approved basic 10-107756 BP	2009 IRC	Plan# 466-A	2-story sfr w/attached g	2011
New	Approved basic 11-105341 BP	2009IRC	Plan# 471	2-story sfr w/attached garage	2011
New	Approved basic 10-108039 BP	2009 IRC	Plan# 495 Standard Garage	2-story sfr w/at	2011
New	Approved basic 10-107758 BP	2009 IRC	Plan# 466-B	2-story sfr w/attached gara	2011
New	Approved basic 10-107740 BP	2009 IRC	Plan# 461	2-story sfr w/attached garage	2011
New	Approved basic 11-106183 BP	2009 IRC	Plan# 464-A	2-story sfr w/attached gara	2011
New	Approved basic 10-108039 BP	2009 IRC	Plan# 495 Standard Garage	2-story sfr w/at	2011
New	Permit revised 01-03-2012 jrlind	Approved basic 10-107740 BP	2009 IRC	Plan# 461	2011
New	Approved basic 11-106183 BP	2009 IRC	Plan# 464-A	2-story sfr w/attached gara	2011
New	Approved basic 10-106689 BP	2009 IRC	Plan# Jupiter	2-story sfr w/attached gara	2011
New	Approved basic 10-105569 BP	2009 IRC	Plan # 1701	2-story duplex w/attache	2011
New	Approved basic 10-105567 BP	2009 IRC	Plan# 1962	2-story duplex w/attached ga	2011
New	Approved basic 10-105567 BP	2009 IRC	Plan# 1962	2-story duplex w/attached ga	2011
New	Approved basic 10-106173 BP	2009 IRC	Plan# 2262 C	2-story sfr w/attached gar	2011
New	Approved basic 10-106174 BP	2009 IRC	Plan# 2267 B	2-story sfr w/attached garage	2011
New	Approved basic 10-106173 BP	2009 IRC	Plan# 2262 C	2-story sfr w/attached gar	2011
New	Approved basic 10-106174 BP	2009 IRC	Plan# 2267 B	2-story sfr w/attached garage	2011
New	Approved basic 10-105568 BP	2009 IRC	Plan # 2070	2-story sfr w/attached gara	2011
New	SFR, two story style home with attached 3 car garage and wrap around covered porch				2011
New	SFR, 2 bedrooms, 1 bath, approx 768 sqft				2011

Accessory Dwelling Units

Index # - File Name: 1.0022 - Single Family Dwellings Data\_Snohomish County.pdf

New	SFR - rambler style with 2 car garage, covered porch, covered front entry & unfinished basemen				2011
New	2-story sfr no garage				2011
New	Approved basic 09-100630 BP	2006 IRC	Plan#2268-02 AB	2-story sfr w/attached gar	2011
New	Duplex, two story style with attached garage and covered porch				2011
New	Approved basic 11-100399 BP	2009 IRC	Plan# Unit C	2-story sfr no garage	2011
New	Approved basic 10-107468 BP	2009 IRC	Plan# 3725-B	2-story sfr w/attached gara	2011
New	Approved basic 10-106094 BP	2009 IRC	Plan# 3724-A	2-story sfr w/attached gara	2011
New	Approved basic 10-107466 BP	2009 IRC	Plan# 3722-B	2-story sfr w/attached garage	2011
New	Approved basic 10-107464 BP	2009 IRC	Plan# 3721-B	2-story sfr w/attached garag	2011
New	Approved basic 10-107468 BP	2009 IRC	Plan# 3725-B	2-story sfr w/attached gara	2011
New	Approved basic 10-106095 BP	2009 IRC	Plan # 3724-B	2-story sfr w/attached garag	2011
New	Approved basic 10-107036 BP	2009 IRC	Plan # 3726-B	2-story sfr w/attached garage	2011
New	Approved basic 10-107467 BP	2009 IRC	Plan# 3725-A	2-story sfr w/attached gara	2011
New	Approved basic 10-106094 BP	2009 IRC	Plan# 3724-A	2-story sfr w/attached gara	2011
New	Approved basic 10-107463 BP	2009 IRC	Plan# 3721-A	2-story sfr w/attached gara	2011
New	Approved basic 10-107468 BP	2009 IRC	Plan# 3725-B	2-story sfr w/attached gara	2011
New	Approved basic 10-107465 BP	2009 IRC	Plan# 3722-A	2-story sfr w/attached gara	2011
New	Approved basic 10-106095 BP	2009 IRC	Plan # 3724-B	2-story sfr w/attached garag	2011
New	Approved basic 10-107035 BP	2009 IRC	Plan# 3726-A	2-story sfr w/attached gi	2011
New	Approved basic 10-108094 BP	2009 IRC	Plan# 3705-AB	2-story sfr w/attached ga	2011
New	Approved basic 10-107462 BP	2009 IRC	Plan# 3720-B	2-story sfr w/attached gara	2011
New	Approved basic 11-103499 BP	2009 IRC	Plan# 3904-B	2-story sfr w/attached g	2011
New	Approved basic 10-107461 BP	2009 IRC	Plan# 3720-A	2-story sfr w/attached gara	2011
New	Approved basic 10-107464 BP	2009 IRC	Plan# 3721-B	2-story sfr w/attached garag	2011
New	Approved basic 10-107750 BP	2009 IRC	Plan# 3706-B	2-story sfr w/attached g	2011
New	Approved basic 10-107465 BP	2009 IRC	Plan# 3722-A	2-story sfr w/attached gara	2011
New	Approved basic 10-107461 BP	2009 IRC	Plan# 3720-A	2-story sfr w/attached gara	2011
New	Approved basic 10-108094 BP	2009 IRC	Plan# 3705-AB	2-story sfr w/attached ga	2011
New	Approved basic 10-107749 BP	2009 IRC	Plan# 3706-A	2-story sfr w/attached gara	2011
New	Approved basic 10-107462 BP	2009 IRC	Plan# 3720-B	2-story sfr w/attached gara	2011
New	Approved basic 10-107749 BP	2009 IRC	Plan# 3706-A	2-story sfr w/attached gara	2011
New	Approved basic 10-108094 BP	2009 IRC	Plan# 3705-AB	2-story sfr w/attached ga	2011
New	Approved basic 11-103499 BP	2009 IRC	Plan# 3904-B	2-story sfr w/attached g	2011
New	Approved basic 10-107758 BP	2009 IRC	Plan# 466-B	2-story sfr w/attached gara	2011
New	Approved basic 10-107739 BP	2009 IRC	Plan# 446	2-story sfr w/attached gar	2011
New	Approved basic 10-107756 BP	2009 IRC	Plan# 466-A	2-story sfr w/attached g	2011
New	Approved basic 10-107740 BP	2009 IRC	Plan# 461	2-story sfr w/attached garage	2011
New	Approved basic 10-107740 BP	2009 IRC	Plan# 461	2-story sfr w/attached garage	2011
New	Approved basic 10-107740 BP	2009 IRC	Plan# 461	2-story sfr w/attached garage	2011
New	Approved basic 11-101151 BP	2009 IRC	Plan# 468	2-story sfr w/attached garage	2011
New	Approved basic 10-107756 BP	2009 IRC	Plan# 466-A	2-story sfr w/attached g	2011
New	Approved basic 10-108039 BP	2009 IRC	Plan# 495 Standard Garage	2-story sfr w/at	2011
New	Approved basic 10-109379 BP	2009 IRC	Plan# 3189-39-9	2-story sfr w/attached ga	2011
New	Approved basic 10-109377 BP	2009 IRC	Plan# 2569-40-8	2-story sfr w/attache	2011
New	Approved basic 10-109378 BP	2009 IRC	Plan# 2726-49-8	2-story sfr w/attache	2011
New	Approved basic 10-109375 BP	2009 IRC	Plan# 2006-40-8	2-story sfr w/attached ga	2011
New	Approved basic 10-109376 BP	2009 IRC	Plan# 2230-50-8	2-story sfr w/attached ga	2011

Accessory Dwelling Units

Index # - File Name: 1.0022 - Single Family Dwellings Data\_Snohomish County.pdf

New	Approved basic 10-109376 BP	2009 IRC	Plan# 2230-50-8	2-story sfr w/attached gar	2011
New	Approved basic 10-109566 BP	2009 IRC	Plan# 2180-40-8	2-story sfr w/attac	2011
New	Approved basic 10-109375 BP	2009 IRC	Plan# 2006-40-8	2-story sfr w/attached g	2011
New	Approved basic 10-109377 BP	2009 IRC	Plan# 2569-40-8	2-story sfr w/attache	2011
New	Approved basic 10-109378 BP	2009 IRC	Plan# 2726-49-8	2-story sfr w/attache	2011
New	Approved basic 10-109379 BP	2009 IRC	Plan# 3189-39-9	2-story sfr w/attached ga	2011
New	Approved basic 10-109566 BP	2009 IRC	Plan# 2180-40-8	2-story sfr w/attac	2011
New	Approved basic 11-101366 BP	2009 IRC	Plan# 2666A	2-story sfr finished baseme	2011
New	Approved basic 10-108379 BP	2009 IRC	Plan# 2472A - 09	2-story sfr w/attached	2011
New	Approved basic 10-108198 BP	2009 IRC	Plan# 2440 A-09	2-story sfr w/attached gar	2011
New	Manufactured home, 2011 Fleetwood, 26 x 64				2011
New	Approved basic 11-100765 BP	2009 IRC	Plan # 1993 A	2-story sfr w/attached gar	2011
New	Approved basic 11-100765 BP	2009 IRC	Plan # 1993 A	2-story sfr w/attached gar	2011
New	Approved basic 11-100762 BP	2009 IRC	Plan# 2206 A	2-story sfr w/attached gar:	2011
New	Approved basic 11-100765 BP	2009 IRC	Plan # 1993 A	2-story sfr w/attached gar	2011
New	Approved basic 11-100766 BP	2009 IRC	Plan# 2462 B	2-story sfr w/attached gara	2011
New	Approved basic 11-100764 BP	2009 IRC	Plan# 2206 B	2-story sfr w/attached ga	2011
New	Approved basic 11-100763 BP	2009 IRC	Plan# 2462 A	2-story sfr w/attached ga	2011
New	Approved basic 11-100765 BP	2009 IRC	Plan # 1993 A	2-story sfr w/attached gar	2011
New	Approved basic 11-100762 BP	2009 IRC	Plan# 2206 A	2-story sfr w/attached gar:	2011
New	Approved basic 11-100765 BP	2009 IRC	Plan # 1993 A	2-story sfr w/attached gar	2011
New	Approved basic 11-100764 BP	2009 IRC	Plan# 2206 B	2-story sfr w/attached ga	2011
New	Approved basic 11-100765 BP	2009 IRC	Plan # 1993 A	2-story sfr w/attached gar	2011
New	Approved basic 11-100762 BP	2009 IRC	Plan# 2206 A	2-story sfr w/attached gar:	2011
New	Approved basic 11-100764 BP	2009 IRC	Plan# 2206 B	2-story sfr w/attached ga	2011
New	Approved basic 11-100765 BP	2009 IRC	Plan # 1993 A	2-story sfr w/attached gar	2011
New	Approved basic 11-100765 BP	2009 IRC	Plan # 1993 A	2-story sfr w/attached gar:	2011
New	Approved basic 11-100764 BP	2009 IRC	Plan# 2206 B	2-story sfr w/attached ga	2011
New	Approved basic 11-100765 BP	2009 IRC	Plan # 1993 A	2-story sfr w/attached gar	2011
New	Approved basic 11-100762 BP	2009 IRC	Plan# 2206 A	2-story sfr w/attached gar:	2011
New	Approved basic 11-100765 BP	2009 IRC	Plan # 1993 A	2-story sfr w/attached gar	2011
New	Approved basic 11-100764 BP	2009 IRC	Plan# 2206 B	2-story sfr w/attached ga	2011
New	Approved basic 11-100762 BP	2009 IRC	Plan# 2206 A	2-story sfr w/attached gar:	2011
New	Approved basic 11-100765 BP	2009 IRC	Plan # 1993 A	2-story sfr w/attached gar	2011
New	Approved basic 11-100766 BP	2009 IRC	Plan# 2462 B	2-story sfr w/attached gara	2011
New	Approved basic 11-100763 BP	2009 IRC	Plan# 2462 A	2-story sfr w/attached ga	2011
New	Approved basic 11-100766 BP	2009 IRC	Plan# 2462 B	2-story sfr w/attached gara	2011
New	Approved basic 11-100762 BP	2009 IRC	Plan# 2206 A	2-story sfr w/attached gar:	2011
New	Approved basic 11-100764 BP	2009 IRC	Plan# 2206 B	2-story sfr w/attached ga	2011
New	Approved basic 11-100555 BP	2009 IRC	Plan# 3310-03AB	2-story sfr w/attached gar	2011
New	Approved basic 11-102290 BP	2009 IRC	Plan# 2268-02AB	2-story sfr w/attached	2011
New	SFR, rambler style with attached two-car garage				2011
New	Approved basic 11-100764 BP	2009 IRC	Plan# 2206 B	2-story sfr w/attached ga	2011
New	Approved basic 11-103012 BP	2009 IRC	Plan# 2368-03AB	3 story sfr w/tuck unde	2011
New	Approved basic 11-103012 BP	2009 IRC	Plan# 2368-03AB	3 story sfr w/tuck unde	2011
New	Approved basic 11-100555 BP	2009 IRC	Plan# 3310-03AB	2-story sfr w/attached gar	2011
New	Approved basic 11-100554 BP	2009 IRC	Plan# 2763-03AB	2-story sfr w/attached ga	2011

Accessory Dwelling Units

Index # - File Name: 1.0022 - Single Family Dwellings Data\_Snohomish County.pdf

New	Approved basic 11-101753 BP	2009 IRC	Plan# 2533-03AB	2-story sfr w/attached garage	2011
New	Approved basic 11-101362 BP	2009 IRC	Plan# 2950-03AD	2-story sfr w/attached garage	2011
New	Approved basic 11-100554 BP	2009 IRC	Plan# 2763-03AB	2-story sfr w/attached garage	2011
New	Approved basic 11-106319 BP	2009 IRC	Plan# 2124	2-story sfr w/attached garage	2011
New	Approved basic 11-106320 BP	2009 IRC	Plan# 2140	2-story sfr w/attached garage	2011
New	Two-story SFR with attached garage - 2009 IRC				2011
New	Approved basic 10-107734 BP	2009 IRC	Plan# 1856	Mid entry sfr w/attached garage	2011
New	Approved basic 10-107529 BP	2009 IRC	Plan#2033	Mid entry sfr w/attached garage	2011
New	Approved basic 10-107526 BP	2009 IRC	Plan# 1903	Mid entry sfr w/attached garage	2011
New	Approved basic 10-107529 BP	2009 IRC	Plan#2033	Mid entry sfr w/attached garage	2011
New	Mid entry sfr w/attached garage				2011
New	Two-story SFR with attached garage - 2009 IRC				2011
New	2441 sf SFR with attached garage - 2009 IRC				2011
New	Approved basic 11-106319 BP	2009 IRC	Plan# 2124	2-story sfr w/attached garage	2011
New	Approved basic 11-106320 BP	2009 IRC	Plan# 2140	2-story sfr w/attached garage	2011
New	Approved basic 11-106980 BP	2009 IRC	Plan# Madison II-B	2-story sfr w/attached garage	2011
New	Approved basic 10-107171 BP	2009 IRC	Plan# Chellan II-A (3 Car)	2-story sfr w/attached garage	2011
New	Approved basic 10-109013 BP	2009 IRC	Plan# Granite A	2-story sfr w/attached garage	2011
New	Approved basic 11-105359 BP	2009 IRC	Plan# Glacier-B	2-story sfr w/attached garage	2011
New	Approved basic 11-105360 BP	2009 IRC	Plan# Cascade-B 3 car	2-story sfr w/attached garage	2011
New	Approved basic 10-105537 BP	2009 IRC	Plan # Blakely B	2-story sfr w/attached garage	2011
New	Approved basic 10-109259 BP	2009 IRC	Plan# Campbell II A	2-story sfr w/attached garage	2011
New	Approved basic 11-105360 BP	2009 IRC	Plan# Cascade-B 3 car	2-story sfr w/attached garage	2011
New	Approved basic 11-106980 BP	2009 IRC	Plan# Madison II-B	2-story sfr w/attached garage	2011
New	Approved basic 10-109261 BP	2009 IRC	Plan# langley II B	2-story sfr w/attached garage	2011
New	Approved basic 11-102545 BP	2009 IRC	Plan# Barclay A	3-story sfr w/attached garage	2011
New	Approved basic 11-102548 BP	2009 IRC	Plan# Decatur A	3-story sfr w/attached garage	2011
New	Approved basic 11-105854 BP	2009 IRC	Plan# Windom-B	3-story sfr w/attached garage	2011
New	Approved basic 10-108456 BP	2009 IRC	Plan# Shasta II-B	2-story sfr w/attached garage	2011
New	Approved basic 10-108468 BP	2009 IRC	Plan# 2801 SW	3-story sfr w/tuck under garage	2011
New	Approved basic 10-108466 BP	2009 IRC	Plan# 2175 SW	3-story sfr w/tuck under garage	2011
New	Approved basic 10-108466 BP	2009 IRC	Plan# 2175 SW	3-story sfr w/tuck under garage	2011
New	Approved basic 10-103608 BP	2009 IRC	Plan# 1670 SW	2-story sfr w/attached garage	2011
New	Approved basic 10-101193 BP	2006 IRC	Plan# Selkirk - B	2-story sfr w/attached garage	2011
New	Approved basic 10-101193 BP	2006 IRC	Plan# Selkirk - B	2-story sfr w/attached garage	2011
New	Approved basic 10-106958 BP	2009 IRC	Plan# Rainier B	2-story sfr w/attached garage	2011
New	Approved basic 10-108454 BP	2009 IRC	Plan# Hazelwood-B	2-story sfr w/attached garage	2011
New	Approved basic 10-109012 BP	2009 IRC	Plan# Mansfield B	2-story sfr w/attached garage	2011
New	Approved basic 10-109013 BP	2009 IRC	Plan# Granite A	2-story sfr w/attached garage	2011
New	Approved basic 09-104646 BP	2006 IRC	Plan# Dayton A	2-story sfr w/attached garage	2011
New	Approved basic 10-106992 BP	2009 IRC	Plan# 2195-0	2-story sfr w/attached garage	2011
New	Approved basic 10-106988 BP	2009 IRC	Plan# 2448	2-story sfr w/attached garage	2011
New	2-story sfr w/attached garage				2011
New	2-story sfr w/attached garage				2011
New	Approved basic 10-106693 BP	2009 IRC	Plan# Julia	2-story sfr w/attached garage	2011
New	New single story, A-frame style home with covered decks Revision of plans to change foundation				2011
New	Approved basic 10-108109 BP	2009 IRC	Plan# 2140	2-story sfr w/attached garage	2011

Accessory Dwelling Units

Index # - File Name: 1.0022 - Single Family Dwellings Data\_Snohomish County.pdf

New	Approved basic 10-108109 BP	2009 IRC	Plan# 2140	2-story sfr w/attached garage	2011
New	Approved Basic 08-106996-BP	Plan No. 2368-03AB	2006 IRC	3 story SFR w/ 1st story gar	2011
New	Approved Basic 08-105360-BP	Plan No. 2357-02Av2	2006 IRC	2 story SFR w/ attached	2011
New	Approved Basic 08-105361-BP	Plan No 2245-02Av2	2006 IRC	2 story SFR w/attached gara	2011
New	2-story sfr w/attached garage				2011
New	Manufactured home, 2010 double wide Palm Harbor				2011
New	Approved basic 10-107035 BP	2009 IRC	Plan# 3726-A	2-story sfr w/attached ga	2011
New	Approved basic 10-106093 BP	2009 IRC	Plan# 3723-AB	2-story sfr w/attached gara	2011
New	Approved basic 10-106095 BP	2009 IRC	Plan # 3724-B	2-story sfr w/attached gara	2011
New	Approved basic 10-107466 BP	2009 IRC	Plan# 3722-B	2-story sfr w/attached garage	2011
New	Approved basic 10-107036 BP	2009 IRC	Plan # 3726-B	2-story sfr w/attached garage	2011
New	Approved basic 10-107461 BP	2009 IRC	Plan# 3720-A	2-story sfr w/attached gara	2011
New	Approved basic 10-106095 BP	2009 IRC	Plan # 3724-B	2-story sfr w/attached gara	2011
New	Approved basic 10-108094 BP	2009 IRC	Plan# 3705-AB	2-story sfr w/attached ga	2011
New	Approved basic 10-107462 BP	2009 IRC	Plan# 3720-B	2-story sfr w/attached gara	2011
New	Approved basic 10-106095 BP	2009 IRC	Plan # 3724-B	2-story sfr w/attached gara	2011
New	Approved basic 10-107465 BP	2009 IRC	Plan# 3722-A	2-story sfr w/attached gara	2011
New	Approved basic 10-106094 BP	2009 IRC	Plan# 3724-A	2-story sfr w/attached gara	2011
New	Approved basic 10-106093 BP	2009 IRC	Plan# 3723-AB	2-story sfr w/attached gara	2011
New	Approved basic 10-107461 BP	2009 IRC	Plan# 3720-A	2-story sfr w/attached gara	2011
New	Approved basic 10-107036 BP	2009 IRC	Plan # 3726-B	2-story sfr w/attached garage	2011
New	Approved basic 10-106093 BP	2009 IRC	Plan# 3723-AB	2-story sfr w/attached gara	2011
New	Approved basic 10-106095 BP	2009 IRC	Plan # 3724-B	2-story sfr w/attached gara	2011
New	Approved basic 10-107036 BP	2009 IRC	Plan # 3726-B	2-story sfr w/attached garage	2011
New	Approved basic 11-102895 BP	2009 IRC	Plan# 3727-B	2-story sfr w/attached gara	2011
New	Approved basic 10-106093 BP	2009 IRC	Plan# 3723-AB	2-story sfr w/attached gara	2011
New	Approved basic 10-100186 BP	2006 IRC	Plan# Whitman A	2-story sfr w/attached gara	2011
New	Approved basic 10-107477 BP	2009 IRC	Plan# Dayton A	2-story sfr w/attached gara	2011
New	Approved basic 10-101193 BP	2006 IRC	Plan# Selkirk - B	2-story sfr w/attached ga	2011
New	Approved basic 10-108454 BP	2009 IRC	Plan# Hazelwood-B	2-story sfr w/attached	2011
New	Approved basic 10-106996 BP	2009 IRC	Plan# Kitsap A	2-story sfr w/attached gara	2011
New	Approved basic 10-100187 BP	2006 IRC	Plan# Whitman B	2-story sfr w/attached	2011
New	Approved basic 10-106997 BP	2009 IRC	Plan# Newman A	2-story sfr w/attach	2011
New	Approved basic 10-101193 BP	2006 IRC	Plan# Selkirk - B	2-story sfr w/attached ga	2011
New	Approved basic 10-100186 BP	2006 IRC	Plan# Whitman A	2-story sfr w/attached gara	2011
New	Approved basic 10-106958 BP	2009 IRC	Plan# Rainier B	2-story sfr w/attached gai	2011
New	Approved basic 11-106980 BP	2009 IRC	Plan# Madison II-B	2-story sfr w/attached	2011
New	Approved basic 11-105854 BP	2009 IRC	Plan# Windom-B	3-story sfr w/attached	2011
New	Approved basic 11-102547 BP	2009 IRC	Plan# Skagit A	2-story sfr w/attached ga	2011
New	Approved basic 10-109012 BP	2009 IRC	Plan# Mansfield B	2-story sfr w/attached	2011
New	Approved basic 10-108454 BP	2009 IRC	Plan# Hazelwood-B	2-story sfr w/attached	2011
New	Approved basic 11-107223 BP	2009 IRC	Plan# Kitsap B	2-story sfr w/attached gara	2011
New	Approved basic 10-107477 BP	2009 IRC	Plan# Dayton A	2-story sfr w/attached gara	2011
New	Approved basic 11-107224 BP	2009 IRC	Plan# Hazelwood A	2-story sfr w/attached g	2011
New	Approved basic 11-107397 BP	2009 IRC	Plan# Wrangell A	2-story sfr w/attache	2011
New	Approved basic 10-109011 BP	2009 IRC	Plan# Mansfield A	2-story sfr w/attache	2011
New	Approved basic 10-106996 BP	2009 IRC	Plan# Kitsap A	2-story sfr w/attached gara	2011

Accessory Dwelling Units

Index # - File Name: 1.0022 - Single Family Dwellings Data\_Snohomish County.pdf

New	Approved basic 10-106962 BP	2009 IRC	Plan # Adams A	2-story sfr w/attached garage	2011
New	Approved basic 10-107477 BP	2009 IRC	Plan# Dayton A	2-story sfr w/attached garage	2011
New	Approved basic 10-107478 BP	2009 IRC	Plan# Jameson A	2-story sfr w/attached garage	2011
New	Approved basic 10-109013 BP	2009 IRC	Plan# Granite A	2-story sfr w/attached garage	2011
New	Approved basic 10-107478 BP	2009 IRC	Plan# Jameson A	2-story sfr w/attached garage	2011
New	Two-story SFR with attached garage - 2009 IRC				2011
New	2-story sfr w/attached garage				2011
New	Approved Basic 09-100748-BP	Plan # W2506	2006 IBC	2-Story SFR w/ 3-car garage	2011
New	2-story sfr w/attached garage				2011
New	Original Expire date 8/10/14 - reopened for a 1 time inspection for final per Tom Rowe EXPIRED				2011
New	Approved basic 10-103613 BP	2009 IRC	Plan# 2493 SW	2-story sfr w/attached garage	2011
New	Approved basic 10-103612 BP	2009 IRC	Plan# 2370 SW	2-story sfr w/attached garage	2011
New	Approved basic 10-103613 BP	2009 IRC	Plan# 2493 SW	2-story sfr w/attached garage	2011
New	Approved basic 10-103612 BP	2009 IRC	Plan# 2370 SW	2-story sfr w/attached garage	2011
New	Approved basic 10-103610 BP	2009 IRC	Plan# 2023 SW	2-story sfr w/attached garage	2011
New	Approved basic 10-108466 BP	2009 IRC	Plan# 2175 SW	3-story sfr w/tuck under garage	2011
New	Approved basic 10-108466 BP	2009 IRC	Plan# 2175 SW	3-story sfr w/tuck under garage	2011
New	Approved basic 10-108466 BP	2009 IRC	Plan# 2175 SW	3-story sfr w/tuck under garage	2011
New	Approved basic 10-108466 BP	2009 IRC	Plan# 2175 SW	3-story sfr w/tuck under garage	2011
New	Approved basic 10-108468 BP	2009 IRC	Plan# 2801 SW	3-story sfr w/tuck under garage	2011
New	Approved basic 10-108468 BP	2009 IRC	Plan# 2801 SW	3-story sfr w/tuck under garage	2011
New	Approved basic 10-108467 BP	2009 IRC	Plan# 2603 SW	3-story sfr w/tuck under garage	2011
New	Approved basic 10-108468 BP	2009 IRC	Plan# 2801 SW	3-story sfr w/tuck under garage	2011
New	Approved basic 10-108468 BP	2009 IRC	Plan# 2801 SW	3-story sfr w/tuck under garage	2011
New	Approved basic 10-103613 BP	2009 IRC	Plan# 2493 SW	2-story sfr w/attached garage	2011
New	Approved basic 10-103612 BP	2009 IRC	Plan# 2370 SW	2-story sfr w/attached garage	2011
New	Approved basic 10-103612 BP	2009 IRC	Plan# 2370 SW	2-story sfr w/attached garage	2011
New	Approved basic 10-103612 BP	2009 IRC	Plan# 2370 SW	2-story sfr w/attached garage	2011
New	Approved basic 11-104259 BP	2009 IRC	Plan# 3015B	2-story sfr w/attached garage	2011
New	Approved basic 11-104257 BP	2009 IRC	Plan# 3012A	2-story sfr w/attached garage	2011
New	Approved basic 11-104256 BP	2009 IRC	Plan# 3015A	2-story sfr w/attached garage	2011
New	Approved basic 11-104260 BP	2009 IRC	Plan#3012B	2-story sfr w/attached garage	2011
New	Approved basic 11-103615 BP	2009 IRC	Plan# 3019C	2-story sfr w/attached garage	2011
New	Approved basic 11-104259 BP	2009 IRC	Plan# 3015B	2-story sfr w/attached garage	2011
New	Approved basic 11-103610 BP	2009 IRC	Plan# 2422B	2-story sfr w/attached garage	2011
New	Approved basic 11-104256 BP	2009 IRC	Plan# 3015A	2-story sfr w/attached garage	2011
New	Approved basic 11-103612 BP	2009 IRC	Plan# 3019A	2-story sfr w/attached garage	2011
New	Approved basic 11-103615 BP	2009 IRC	Plan# 3019C	2-story sfr w/attached garage	2011
New	Approved basic 11-103608 BP	2009 IRC	Plan# 3019B	2-story sfr w/attached garage	2011
New	Approved basic 11-104256 BP	2009 IRC	Plan# 3015A	2-story sfr w/attached garage	2011
New	Approved basic 11-104257 BP	2009 IRC	Plan# 3012A	2-story sfr w/attached garage	2011
New	Approved basic 11-103617 BP	2009 IRC	Plan# 2422A	2-story sfr w/attached garage	2011
New	Approved basic 11-104259 BP	2009 IRC	Plan# 3015B	2-story sfr w/attached garage	2011
New	Approved basic 11-104260 BP	2009 IRC	Plan#3012B	2-story sfr w/attached garage	2011
New	Approved basic 11-103612 BP	2009 IRC	Plan# 3019A	2-story sfr w/attached garage	2011
New	Approved basic 11-104256 BP	2009 IRC	Plan# 3015A	2-story sfr w/attached garage	2011
New	Approved basic 11-104260 BP	2009 IRC	Plan#3012B	2-story sfr w/attached garage	2011



Accessory Dwelling Units

Index # - File Name: 1.0022 - Single Family Dwellings Data\_Snohomish County.pdf

New	Approved basic 11-103608 BP	2009 IRC	Plan# 3019B	2-story sfr w/attached	2011
New	Approved basic 11-104257 BP	2009 IRC	Plan# 3012A	2-story sfr w/attached garage	2011
New	Approved basic 11-104257 BP	2009 IRC	Plan# 3012A	2-story sfr w/attached garage	2011
New	Approved basic 11-104259 BP	2009 IRC	Plan# 3015B	2-story sfr w/attached garag	2011
New	Approved basic 11-104257 BP	2009 IRC	Plan# 3012A	2-story sfr w/attached garage	2011
New	Approved basic 11-103608 BP	2009 IRC	Plan# 3019B	2-story sfr w/attached	2011
New	Approved basic 11-104260 BP	2009 IRC	Plan#3012B	2-story sfr w/attached garag	2011
New	Approved basic 11-103610 BP	2009 IRC	Plan# 2422B	2-story sfr w/attached g	2011
New	Approved basic 11-104257 BP	2009 IRC	Plan# 3012A	2-story sfr w/attached garage	2011
New	Approved basic 11-104259 BP	2009 IRC	Plan# 3015B	2-story sfr w/attached garag	2011
New	Approved basic 10-103613 BP	2009 IRC	Plan# 2493 SW	2-story sfr w/attached garag	2011
New	Approved basic 10-103612 BP	2009 IRC	Plan# 2370 SW	2-story sfr w/attached garag	2011
New	Approved basic 10-103610 BP	2009 IRC	Plan# 2023 SW	2-story sfr w/attached garage	2011
New	Approved basic 10-103611 BP	2009 IRC	Plan# 2217 SW	2-story sfr w/attached garağ	2011
New	Approved basic 10-103612 BP	2009 IRC	Plan# 2370 SW	2-story sfr w/attached garag	2011
New	Approved basic 10-103610 BP	2009 IRC	Plan# 2023 SW	2-story sfr w/attached garage	2011
New	Approved basic 10-103610 BP	2009 IRC	Plan# 2023 SW	2-story sfr w/attached garage	2011
New	Duplex, two story with attached garage				2011
New	Approved basic 10-103612 BP	2009 IRC	Plan# 2370 SW	2-story sfr w/attached garag	2011
New	SFR, two story with attached 3 car garage				2011
New	SFR, two story with attached 3 car garage				2011
New	Approved basic 11-104251 BP	2009 IRC	Plan# 2422A	2-story sfr w/attached garag	2011
New	Approved basic 11-104250 BP	2009 IRC	Plan# 3019C	2-story sfr w/attached garage	2011
New	Approved basic 11-104251 BP	2009 IRC	Plan# 2422A	2-story sfr w/attached garag	2011
New	2-story sfr w/attached garage				2011
New	Approved basic 11-104252 BP	2009 IRC	Plan# 3013A	2-story sfr w/attached garage	2011
New	Approved basic 11-104248 BP	2009 IRC	Plan# 3014C	2-story sfr w/attached garagi	2011
New	Approved basic 11-104254 BP	2009 IRC	Plan# 3013C	2-story sfr w/attached garage	2011
New	Approved basic 11-104250 BP	2009 IRC	Plan# 3019C	2-story sfr w/attached garage	2011
New	Approved basic 11-104253 BP	2009 IRC	Plan# 3014B	2-story sfr w/attached garage	2011
New	Approved basic 11-104249 BP	2009 IRC	Plan# 3019A	2-story sfr w/attached garage	2011
New	Approved basic 11-104252 BP	2009 IRC	Plan# 3013A	2-story sfr w/attached garage	2011
New	Approved basic 11-104248 BP	2009 IRC	Plan# 3014C	2-story sfr w/attached garagi	2011
New	Approved basic 11-104249 BP	2009 IRC	Plan# 3019A	2-story sfr w/attached garage	2011
New	Approved basic 11-104253 BP	2009 IRC	Plan# 3014B	2-story sfr w/attached garage	2011
New	Manufactured home, used, double wide, 27 x 40				2011
New	Two-story SFR with attached garage - 2009 IRC				2011
New	Email requesting to use the 30 extension Under documents (org expire date 9/2/14) 2592 sf sfr				2011
New	Approved basic 10-107529 BP	2009 IRC	Plan#2033	Mid entry sfr w/attached gar	2011
New	Approved basic 11-107552 BP	2009 IRC	Plan# 2162	2-story sfr w/attached garag	2011
New	Approved basic 11-107560 BP	2009 IRC	Plan# 1924	2-story sfr w/attached garag	2011
New	Approved basic 11-107551 BP	2009 IRC	Plan# 2244	2-story sfr w/attached garage	2011
New	Approved basic 11-107564 BP	2009 IRC	Plan# 2202	2-story sfr w/attached gar	2011
New	Approved basic 11-107558 BP	2009 IRC	Plan# 2000	2-story sfr w/attached garağ	2011
New	Approved basic 11-107552 BP	2009 IRC	Plan# 2162	2-story sfr w/attached garag	2011
New	PERMIT REVISION 08-28-2012			2-story sfr w/attached garage	2011
New	Approved basic 11-107028 BP	2009 IRC	Plan# 4698 - 3 car	Rambler daylight bas	2011

Accessory Dwelling Units

Index # - File Name: 1.0022 - Single Family Dwellings Data\_Snohomish County.pdf

New	Approved basic 10-107153 BP	2009 IRC	Plan# 1223 Duplex	2-story Duplex w/attached	2011
New	Two story home with attached 3 car garage				2012
New	SFR, two story home with attached 2 car garage, 4 bedrooms plus media and music room				2012
New	Approved basic 12-100086 BP	2009 IRC	Plan#Whitman-A	2-story sfr w/attached gar	2012
New	Approved basic 11-108138 BP	2009 IRC	Plan# Goldendale A	2-story sfr w/attached	2012
New	Approved basic 11-109973 BP	2009 IRC	Plan# Brooks-A	2-story sfr w/attached	2012
New	Approved basic 12-100935 BP	2009 IRC	Plan# Westport	2-story sfr w/attache	2012
New	Approved basic 11-106643 BP	2009 IRC	Plan# 446	2-story sfr w/attached garage	2012
New	Approved basic 11-106645 BP	2009 IRC	Plan# 466-A	2-story sfr w/attached gara	2012
New	Approved basic 11-106643 BP	2009 IRC	Plan# 446	2-story sfr w/attached garage	2012
New	Approved basic 11-108471 BP	2009 IRC	Plan# 467	2-story sfr w/attached garage	2012
New	Approved basic 11-107088 BP	2009 IRC	Plan# 472	2-story sfr w/attached garage	2012
New	Approved basic 11-106648 BP	2009 IRC	Plan# 466-B	2-story sfr w/attached gara	2012
New	Approved basic 11-106643 BP	2009 IRC	Plan# 446	2-story sfr w/attached garage	2012
New	Approved basic 11-106645 BP	2009 IRC	Plan# 466-A	2-story sfr w/attached gara	2012
New	Approved basic 12-107195 BP	2009 IRC	Plan# Blake B	2-story sfr w/attached gara	2012
New	Approved basic 12-100393 BP	2009 IRC	Plan# Chelan-A	2-story sfr w/attached }	2012
New	Approved basic 11-108137 BP	2009 IRC	Plan# Blake A	2-story sfr w/attached }	2012
New	Approved basic 11-106643 BP	2009 IRC	Plan# 446	2-story sfr w/attached garage	2012
New	Approved basic 11-107088 BP	2009 IRC	Plan# 472	2-story sfr w/attached garage	2012
New	Approved basic 11-106643 BP	2009 IRC	Plan# 446	2-story sfr w/attached garage	2012
New	Approved basic 11-106653 BP	2009 IRC	Plan# 471	2-story sfr w/attached garage	2012
New	Approved basic 11-107088 BP	2009 IRC	Plan# 472	2-story sfr w/attached garage	2012
New	2-story sfr w/attached garage				2012
New	Approved basic 12-107196 BP	2009 IRC	Plan# Goldendale A 3	2-story sfr w/attach	2012
New	Approved basic 12-100393 BP	2009 IRC	Plan# Chelan-A	2-story sfr w/attached }	2012
New	Approved basic 12-100392 BP	2009 IRC	Plan# Paradise-A	2-story sfr w/attached gara	2012
New	Approved basic 12-107195 BP	2009 IRC	Plan# Blake B	2-story sfr w/attached gara	2012
New	Approved basic 11-107088 BP	2009 IRC	Plan# 472	2-story sfr w/attached garage	2012
New	Approved basic 11-106655 BP	2009 IRC	Plan# 461	2-story sfr w/attached garage	2012
New	Approved basic 11-107088 BP	2009 IRC	Plan# 472	2-story sfr w/attached garage	2012
New	Approved basic 12-100392 BP	2009 IRC	Plan# Paradise-A	2-story sfr w/attached gara	2012
New	Approved basic 12-100935 BP	2009 IRC	Plan# Westport	2-story sfr w/attache	2012
New	Approved basic 11-107088 BP	2009 IRC	Plan# 472	2-story sfr w/attached garage	2012
New	Approved basic 11-106653 BP	2009 IRC	Plan# 471	2-story sfr w/attached garage	2012
New	Approved basic 11-106653 BP	2009 IRC	Plan# 471	2-story sfr w/attached garage	2012
New	Approved basic 11-109973 BP	2009 IRC	Plan# Brooks-A	2-story sfr w/attached	2012
New	Approved basic 11-108138 BP	2009 IRC	Plan# Goldendale A	2-story sfr w/attached	2012
New	Approved basic 12-109446 BP	2009 IRC	Plan# Paradise B	2-story sfr w/attached ga	2012
New	Approved basic 11-108137 BP	2009 IRC	Plan# Blake A	2-story sfr w/attached }	2012
New	Approved basic 12-107196 BP	2009 IRC	Plan# Goldendale A 3	2-story sfr w/attach	2012
New	Approved basic 12-104520 BP	2009 IRC	Plan# Brooks - B	2-story sfr w/attached gi	2012
New	Approved basic 11-106643 BP	2009 IRC	Plan# 446	2-story sfr w/attached garage	2012
New	Approved basic 11-106655 BP	2009 IRC	Plan# 461	2-story sfr w/attached garage	2012
New	Approved basic 11-106655 BP	2009 IRC	Plan# 461	2-story sfr w/attached garage	2012
New	Approved basic 11-106648 BP	2009 IRC	Plan# 466-B	2-story sfr w/attached gara	2012
New	Approved basic 11-106643 BP	2009 IRC	Plan# 446	2-story sfr w/attached garage	2012

Accessory Dwelling Units

Index # - File Name: 1.0022 - Single Family Dwellings Data\_Snohomish County.pdf

New	Approved basic 11-106655 BP	2009 IRC	Plan# 461	2-story sfr w/attached garage	2012
New	2-story sfr w/attached garage				2012
New	2-story sfr w/attached garage				2012
New	2- story sfr w/attached garage and unfinished daylight basement				2012
New	2-story sfr w/attached garage				2012
New	2-story sfr w/attached garage				2012
New	2-story sfr w/attached garage				2012
New	2-story sfr w/attached garage				2012
New	2-story sfr w/attached garage				2012
New	2-story sfr w/attached garage				2012
New	2-story sfr w/attached garage				2012
New	2-story sfr w/attached garage				2012
New	2-story sfr w/attached garage				2012
New	2-story sfr w/attached garage				2012
New	2-story sfr w/attached garage				2012
New	2-story sfr w/attached garage				2012
New	2-story sfr w/attached garage				2012
New	2-story sfr w/attached garage				2012
New	2-story sfr w/attached garage				2012
New	2-story sfr w/attached garage				2012
New	2-story sfr w/attached garage				2012
New	2-story sfr w/attached garage				2012
New	2-story sfr w/attached garage				2012
New	2-story sfr w/attached garage and daylight basement			Rear roof drains for lots 9,10, & 11are approved	2012
New	2-story sfr w/attached garage and daylight basement			Rear roof drains for lots 9,10, & 11are approved	2012
New	2-story sfr w/attached garage			Rear roof drains for lots 9,10, & 11are approved for splash blocks	2012
New	Approved basic 12-109250 BP	2009 IRC	Plan# 18-30.02 J HENLEY	2-story sfr w/att	2012
New	Approved basic 12-107261 BP	2009 IRC	Plan# 18-30.02 M	2-story sfr w/attached	2012
New	Approved basic 12-104844 BP	2009 IRC	Plan# 30-30.02 H	2-story sfr w/attached	2012
New	Approved basic 12-109248 BP	2009 IRC	Plan# 1830.02 D Henley	2-story sfr w/attach	2012
New	Approved basic 11-100555 BP	2009 IRC	Plan# 3310-03AB	2-story sfr w/attached gar	2012
New	Two-story SFR with attached garage				2012
New	2033 sf rambler with 625 attached garage - 2009 IRC				2012
New	Approved basic 12-108643 BP	2009 IRC	Plan# 2777	2-story sfr w/attached gara	2012
New	Approved basic 12-100357 BP	2009 IRC	Plan# 2279-30-8	2-story sfr w/attached ga	2012
New	Approved basic 12-100046	2009 IRC	Plan# 1875-30-8	2-storys sfr w/attached gar	2012
New	Approved basic 12-106513 BP	2009 IRC	Plan# 19-30.02 F	2-story sfr w/attache	2012
New	Approved basic 12-108192 BP	2009 IRC	Plan# 20-30.02 C Henley	2-story sfr w/atta	2012
New	Approved basic 12-107261 BP	2009 IRC	Plan# 18-30.02 M	2-story sfr w/attached	2012
New	Approved basic 12-106513 BP	2009 IRC	Plan# 19-30.02 F	2-story sfr w/attache	2012
New	Approved basic 12-100295 BP	2009 IRC	Plan# 17-30D	2-story sfr w/attached garag	2012
New	2-story sfr w/attached garage				2012
New	Approved basic 12-101155 BP	2009 IRC	Plan# 2-30C	2-story sfr w/attached gara	2012
New	Approved basic 12-101156 BP	2009 IRC	Plan# 15-30D	2-story sfr w/attached gar	2012
New	Approved basic 12-103181 BP	2009 IRC	Plan# 19-30.02 H	2-story sfr w/attache	2012
New	Approved basic 12-103182 BP	2009 IRC	Plan# 17-30.02 B	2-story sfr w/attached	2012
New	Approved basic 11-108981 BP	2009 IRC	Plan# 18-30D	2-story sfr w/attached garage	2012
New	Approved basic 12-103729 BP	2009 IRC	Plan# 9-30.02 E	2-story sfr w/attache	2012
New	Approved basic 12-107260 BP	2009 IRC	Plan# 20-30.02M	2-story sfr w/attache	2012
New	Approved basic 12-110654 BP	2009 IRC	Plan# 20-30.02 E (.2)	2-story sfr w/attac	2012

Accessory Dwelling Units

Index # - File Name: 1.0022 - Single Family Dwellings Data\_Snohomish County.pdf

New	Approved	basic 12-109251 BP	2009 IRC	Plan# 30-30.02 H HENLEY	2-story sfr w/att	2012
New	Approved	basic 12-109690 BP	2009 IRC	Plan# 3-30.02 D HENLEY	2-story sfr w/attac	2012
New	Approved	basic 12-104929 BP	2009 IRC	Plan# 8-30-02 J	2-story sfr w/attached g	2012
New	Approved	basic 12-105426 BP	2009 IRC	Plan# 9-30.02B	2-story w/attached ga	2012
New	Approved	basic 12-106454 BP	2009 IRC	Plan# 29-30.06A	2-story sfr w/attached garag	2012
New	Approved	basic 12-104844 BP	2009 IRC	Plan# 30-30.02 H	2-story sfr w/attached	2012
New	Approved	basic 12-104962 BP	2009 IRC	Plan# 18-30.02C	2-story sfr w/attached	2012
New	Approved	basic 12-103728 BP	2009 IRC	Plan# 25-30.12 D	2-story sfr w/attached ga	2012
New	Approved	basic 12-103181 BP	2009 IRC	Plan# 19-30.02 H	2-story sfr w/attache	2012
New	Approved	basic 12-102030 BP	2009 IRC	Plan# 24-30C	2-story sfr w/attached gar	2012
New	Approved	basic 11-108980 BP	2009 IRC	Plan#20-30 F	2-story sfr w/attached gar	2012
New	Approved	basic 12-103182 BP	2009 IRC	Plan# 17-30.02 B	2-story sfr w/attached	2012
New	Approved	basic 12-104352 BP	2009 IRC	Plan# 2-30.02 A	2-story sfr w/attached g	2012
New	Approved	basic 11-106655 BP	2009 IRC	Plan# 461	2-story sfr w/attached garage	2012
New	Approved	basic 12-100408 BP	2009 IRC	Plan# 2808-02AB	2-story sfr w/attached ga	2012
New	Approved	basic 11-109563 BP	2009 IRC	Plan# 2228-02AB	2-story sfr w/attached ga	2012
New	Approved	basic 12-100077 BP	2009 IRC	Plan# 2601-02AB	2-story sfr w/attached g	2012
New	Approved	basic 12-100077 BP	2009 IRC	Plan# 2601-02AB	2-story sfr w/attached g	2012
New	Approved	basic 11-109347 BP	2009 IRC	Plan# 2083-02AB	2-story sfr w/attached gara	2012
New	Approved	basic 10-109025 BP	2009 IRC	Plan# 2384-02AB	2-story sfr w/attache	2012
New	Approved	basic 12-105541 BP	2009 IRC	Plan#2512-02AB	2-story sfr w/attache	2012
New	Approved	Basic 10-107346 BP	2009 IRC	Plan# 2120-02A	2-story sfr w/attached	2012
New	Approved	basic 12-100408 BP	2009 IRC	Plan# 2808-02AB	2-story sfr w/attached ga	2012
New	Approved	basic 12-105541 BP	2009 IRC	Plan#2512-02AB	2-story sfr w/attache	2012
New	Approved	basic 12-100408 BP	2009 IRC	Plan# 2808-02AB	2-story sfr w/attached ga	2012
New	Approved	Basic 10-107346 BP	2009 IRC	Plan# 2120-02A	2-story sfr w/attached	2012
New	Approved	basic 10-109025 BP	2009 IRC	Plan# 2384-02AB	2-story sfr w/attache	2012
New	Approved	basic 12-100408 BP	2009 IRC	Plan# 2808-02AB	2-story sfr w/attached ga	2012
New	Approved	basic 12-105541 BP	2009 IRC	Plan#2512-02AB	2-story sfr w/attache	2012
New	Approved	basic 12-100232 BP	2009 IRC	Plan # 3019 C	2-story sfr w/attached ;	2012
New	Approved	basic 12-100230 BP	2009 IRC	Plan# 3014 C	2-story sfr w/attached ;	2012
New	Approved	basic 12-100224 BP	2009 IRC	Plan# 3013 A	2-story sfr w/attached garag	2012
New	Approved	basic 12-100231 BP	2009 IRC	Plan# 3019 A	2-story sfr w/attached g	2012
New	Approved	basic 12-100229 BP	2009 IRC	Plan# 3014 B	2-story sfr w/attached g	2012
New	Approved	basic 12-100228 BP	2009 IRC	Plan# 3013 C	2-story sfr w/attached	2012
New	Approved	basic 12-100232 BP	2009 IRC	Plan # 3019 C	2-story sfr w/attached ;	2012
New	Approved	basic 12-100230 BP	2009 IRC	Plan# 3014 C	2-story sfr w/attached ;	2012
New	Approved	basic 12-100228 BP	2009 IRC	Plan# 3013 C	2-story sfr w/attached	2012
New	Approved	basic 12-100232 BP	2009 IRC	Plan # 3019 C	2-story sfr w/attached ;	2012
New	Approved	basic 12-100224 BP	2009 IRC	Plan# 3013 A	2-story sfr w/attached garag	2012
New	Approved	basic 12-100229 BP	2009 IRC	Plan# 3014 B	2-story sfr w/attached g	2012
New	Approved	basic 12-100228 BP	2009 IRC	Plan# 3013 C	2-story sfr w/attached	2012
New	Approved	basic 12-100231 BP	2009 IRC	Plan# 3019 A	2-story sfr w/attached g	2012
New	Approved	basic 12-100230 BP	2009 IRC	Plan# 3014 C	2-story sfr w/attached ;	2012
New	Approved	basic 12-100227 BP	2009 IRC	Plan# 2422 A	2-story sfr w/attache	2012
New	Approved	basic 12-100232 BP	2009 IRC	Plan # 3019 C	2-story sfr w/attached ;	2012
New	Approved	basic 12-100227 BP	2009 IRC	Plan# 2422 A	2-story sfr w/attache	2012



Accessory Dwelling Units

Index # - File Name: 1.0022 - Single Family Dwellings Data\_Snohomish County.pdf

New	Approved basic 12-100231 BP	2009 IRC	Plan# 3019 A	2-story sfr w/attached g	2012
New	Approved basic 12-100229 BP	2009 IRC	Plan# 3014 B	2-story sfr w/attached g	2012
New	Approved basic 12-100232 BP	2009 IRC	Plan # 3019 C	2-story sfr w/attached ;	2012
New	Approved basic 12-100228 BP	2009 IRC	Plan# 3013 C	2-story sfr w/attached	2012
New	Approved basic 12-101289 BP	2009 IRC	Plan# K4153A	2-story sfr w/attached g	2012
New	Approved basic 12-101288 BP	2009 IRC	Plan# 4048A	2-story sfr w/attached gara	2012
New	Approved basic 12-101426 BP	2009 IRC	Plan# K4153C	2-story sfr w/attached garage	2012
New	Approved basic 12-101511 BP	2009 IRC	Plan# K4249C	2-story sfr w/attached garag	2012
New	Approved basic 12-101427 BP	2009 IRC	Plan# 4048C	2-story sfr w/attached gara	2012
New	2-story sfr w/attached garage				2012
New	Approved basic 12-101510 BP	2009 IRC	Plan# K4249A	2-story sfr w/attached gara	2012
New	Approved basic 12-101427 BP	2009 IRC	Plan# 4048C	2-story sfr w/attached gara	2012
New	2-story sfr w/attached garage				2012
New	Approved basic 12-102380 BP	2009 IRC	Plan# 1543	Rambler style sfr w/attached g	2012
New	Approved basic 12-102664 BP	2009 IRC	Plan# 1756 Split	Split entry sfr w/attache	2012
New	2-story sfr w/attached garage				2012
New	2-story sfr w/attached garage				2012
New	Two story SFR with attached garage - 2009 IRC				2012
New	New rambler with attached garage and covered porch				2012
New	Approved basic 11-107564 BP	2009 IRC	Plan# 2202	2-story sfr w/attached gar	2012
New	Approved basic 11-107560 BP	2009 IRC	Plan# 1924	2-story sfr w/attached garag	2012
New	Approved basic 11-107558 BP	2009 IRC	Plan# 2000	2-story sfr w/attached gara	2012
New	Approved basic 11-107562 BP	2009 IRC	Plan# 2074	2-story sfr w/attached gara	2012
New	Approved basic 11-107551 BP	2009 IRC	Plan# 2244	2-story sfr w/attached garage	2012
New	Approved basic 11-107552 BP	2009 IRC	Plan# 2162	2-story sfr w/attached garag	2012
New	Approved basic 11-107558 BP	2009 IRC	Plan# 2000	2-story sfr w/attached gara	2012
New	Approved basic 11-107564 BP	2009 IRC	Plan# 2202	2-story sfr w/attached gar	2012
New	Approved basic 11-107552 BP	2009 IRC	Plan# 2162	2-story sfr w/attached garag	2012
New	Approved basic 11-107564 BP	2009 IRC	Plan# 2202	2-story sfr w/attached gar	2012
New	Approved basic 11-107551 BP	2009 IRC	Plan# 2244	2-story sfr w/attached garage	2012
New	Approved basic 11-104253 BP	2009 IRC	Plan# 3014B	2-story sfr w/attached garage	2012
New	Approved basic 11-104249 BP	2009 IRC	Plan# 3019A	2-story sfr w/attached garag	2012
New	Approved basic 11-104253 BP	2009 IRC	Plan# 3014B	2-story sfr w/attached garage	2012
New	Approved basic 11-104250 BP	2009 IRC	Plan# 3019C	2-story sfr w/attached garage	2012
New	Approved basic 11-104254 BP	2009 IRC	Plan# 3013C	2-story sfr w/attached garage	2012
New	Approved basic 11-104248 BP	2009 IRC	Plan# 3014C	2-story sfr w/attached garag	2012
New	2-story sfr w/attachedg garage				2012
New	Approved basic 11-104253 BP	2009 IRC	Plan# 3014B	2-story sfr w/attached garage	2012
New	Approved basic 11-107558 BP	2009 IRC	Plan# 2000	2-story sfr w/attached gara	2012
New	Approved basic 11-107552 BP	2009 IRC	Plan# 2162	2-story sfr w/attached garag	2012
New	Approved basic 11-107558 BP	2009 IRC	Plan# 2000	2-story sfr w/attached gara	2012
New	Approved basic 11-107552 BP	2009 IRC	Plan# 2162	2-story sfr w/attached garag	2012
New	Approved basic 11-107562 BP	2009 IRC	Plan# 2074	2-story sfr w/attached gara	2012
New	Approved basic 11-107562 BP	2009 IRC	Plan# 2074	2-story sfr w/attached gara	2012
New	Approved basic 11-107558 BP	2009 IRC	Plan# 2000	2-story sfr w/attached gara	2012
New	Approved basic 11-107551 BP	2009 IRC	Plan# 2244	2-story sfr w/attached garage	2012
New	Approved basic 11-107558 BP	2009 IRC	Plan# 2000	2-story sfr w/attached gara	2012

Accessory Dwelling Units

Index # - File Name: 1.0022 - Single Family Dwellings Data\_Snohomish County.pdf

New	Approved basic 11-107552 BP	2009 IRC	Plan# 2162	2-story sfr w/attached garag	2012
New	Approved basic 11-107551 BP	2009 IRC	Plan# 2244	2-story sfr w/attached garage	2012
New	Approved basic 11-107552 BP	2009 IRC	Plan# 2162	2-story sfr w/attached garag	2012
New	Approved basic 11-107560 BP	2009 IRC	Plan# 1924	2-story sfr w/attached garag	2012
New	Approved basic 11-107552 BP	2009 IRC	Plan# 2162	2-story sfr w/attached garag	2012
New	Approved basic 11-107558 BP	2009 IRC	Plan# 2000	2-story sfr w/attached gara	2012
New	Approved basic 11-107551 BP	2009 IRC	Plan# 2244	2-story sfr w/attached garage	2012
New	Approved basic 11-107551 BP	2009 IRC	Plan# 2244	2-story sfr w/attached garage	2012
New	Approved basic 11-107558 BP	2009 IRC	Plan# 2000	2-story sfr w/attached gara	2012
New	Approved basic 11-107552 BP	2009 IRC	Plan# 2162	2-story sfr w/attached garag	2012
New	Approved basic 11-107564 BP	2009 IRC	Plan# 2202	2-story sfr w/attached gai	2012
New	Approved basic 11-107552 BP	2009 IRC	Plan# 2162	2-story sfr w/attached garag	2012
New	Approved basic 11-107552 BP	2009 IRC	Plan# 2162	2-story sfr w/attached garag	2012
New	Approved basic 11-107558 BP	2009 IRC	Plan# 2000	2-story sfr w/attached gara	2012
New	Approved basic 11-107551 BP	2009 IRC	Plan# 2244	2-story sfr w/attached garage	2012
New	Approved basic 11-107552 BP	2009 IRC	Plan# 2162	2-story sfr w/attached garag	2012
New	Approved basic 11-107552 BP	2009 IRC	Plan# 2162	2-story sfr w/attached garag	2012
New	Approved basic 12-110050 BP	2009 IRC	Plan# 2417/2	2-story sfr w/atta	2012
New	Approved basic 12-110052 BP	2009 IRC	Plan# 2536/2	2-story sfr w/attache	2012
New	Approved basic 12-110042 BP	2009 IRC	Plan# 2885/2	2-story sfr w/attached garag	2012
New	Approved basic 12-108641 BP	2009 IRC	Plan# 2557	2-story sfr w/attached gara	2012
New	Approved basic 12-108643 BP	2009 IRC	Plan# 2777	2-story sfr w/attached gara	2012
New	Approved basic 12-110052 BP	2009 IRC	Plan# 2536/2	2-story sfr w/attache	2012
New	Two Story SFR with Attached Garage				2012
New	Approved 12-106045 BP	2009 IRC	Plan# 29-30.06B	2-story sfr w/attache	2012
New	Approved basic 12-108193 BP	2009 IRC	Plan# 20-30.02 E Henley	2-story sfr w/atta	2012
New	Approved basic 12-104592 BP	2009 IRC	Plan# 2-30.02 C	2-story sfr w/attached gar	2012
New	Approved basic 12-104357 BP	2009 IRC	Plan# 18-30.02 D	2-story sfr w/attached g	2012
New	Approved basic 12-103181 BP	2009 IRC	Plan# 19-30.02 H	2-story sfr w/attache	2012
New	Approved basic 12-104596 BP	2009 IRC	Plan# 18-30.02 J	2-story sfr w/attached g	2012
New	Approved basic 12-104359 BP	2009 IRC	Plan# 15-30.02 D	2-story sfr w/attache	2012
New	Approved basic 12-104357 BP	2009 IRC	Plan# 18-30.02 D	2-story sfr w/attached g	2012
New	Approved basic 12-104776 BP	2009 IRC	Plan# 15-30.02 H	2-story sfr w/attache	2012
New	Approved basic 12-108193 BP	2009 IRC	Plan# 20-30.02 E Henley	2-story sfr w/atta	2012
New	Approved basic 12-108697 BP	2009 IRC	Plan# 16-30.02 H BED-4 BATH	2-story sfr	2012
New	Approved basic 12-109250 BP	2009 IRC	Plan# 18-30.02 J HENLEY	2-story sfr w/atl	2012
New	Approved basic 12-106513 BP	2009 IRC	Plan# 19-30.02 F	2-story sfr w/attache	2012
New	Approved basic 11-108992 BP	2009 IRC	Plan# 19-30 H	2-story sfr w/attached ga	2012
New	Approved basic 11-106270 BP	2009 IRC	Plan# 16-30 D	2-story sfr w/attached gar	2012
New	2-story sfr w/attached garage				2012
New	Approved basic 11-104251 BP	2009 IRC	Plan# 2422A	2-story sfr w/attached garag	2012
New	Approved basic 11-104249 BP	2009 IRC	Plan# 3019A	2-story sfr w/attached garag	2012
New	Approved basic 11-104251 BP	2009 IRC	Plan# 2422A	2-story sfr w/attached garag	2012
New	Approved basic 11-104250 BP	2009 IRC	Plan# 3019C	2-story sfr w/attached garage	2012
New	2-story sfr w/attached garage				2012
New	Approved basic 11-104251 BP	2009 IRC	Plan# 2422A	2-story sfr w/attached garag	2012
New	Approved basic 11-104254 BP	2009 IRC	Plan# 3013C	2-story sfr w/attached garage	2012

Accessory Dwelling Units

Index # - File Name: 1.0022 - Single Family Dwellings Data\_Snohomish County.pdf

New	Approved basic 11-104250 BP	2009 IRC	Plan# 3019C	2-story sfr w/attached garage	2012
New	Approved basic 11-104248 BP	2009 IRC	Plan# 3014C	2-story sfr w/attached garage	2012
New	2210 sf Rambler with attached garage - 2009 IRC				2012
New	1246 sf SFR with unfinished basement and 182 sf loft - 2009 IRC				2012
New	Approved basic 10-103612 BP	2009 IRC	Plan# 2370 SW	2-story sfr w/attached garage	2012
New	Approved basic 10-103611 BP	2009 IRC	Plan# 2217 SW	2-story sfr w/attached garage	2012
New	Approved basic 10-103613 BP	2009 IRC	Plan# 2493 SW	2-story sfr w/attached garage	2012
New	Approved basic 11-103617 BP	2009 IRC	Plan# 2422A	2-story sfr w/attached garage	2012
New	Approved basic 11-103608 BP	2009 IRC	Plan# 3019B	2-story sfr w/attached garage	2012
New	Approved basic 11-104259 BP	2009 IRC	Plan# 3015B	2-story sfr w/attached garage	2012
New	Approved basic 11-104256 BP	2009 IRC	Plan# 3015A	2-story sfr w/attached garage	2012
New	Approved basic 11-103610 BP	2009 IRC	Plan# 2422B	2-story sfr w/attached garage	2012
New	Approved basic 11-103615 BP	2009 IRC	Plan# 3019C	2-story sfr w/attached garage	2012
New	Revision Approved basic 12-103002 BP	2009 IRC	Plan# 3019 A Revised	2-story sfr	2012
New	Approved basic 11-104256 BP	2009 IRC	Plan# 3015A	2-story sfr w/attached garage	2012
New	Approved basic 10-103612 BP	2009 IRC	Plan# 2370 SW	2-story sfr w/attached garage	2012
New	Approved basic 10-103612 BP	2009 IRC	Plan# 2370 SW	2-story sfr w/attached garage	2012
New	Approved basic 10-103613 BP	2009 IRC	Plan# 2493 SW	2-story sfr w/attached garage	2012
New	Approved basic 10-103612 BP	2009 IRC	Plan# 2370 SW	2-story sfr w/attached garage	2012
New	Approved basic 10-103610 BP	2009 IRC	Plan# 2023 SW	2-story sfr w/attached garage	2012
New	Approved basic 10-103612 BP	2009 IRC	Plan# 2370 SW	2-story sfr w/attached garage	2012
New	Approved basic 10-103613 BP	2009 IRC	Plan# 2493 SW	2-story sfr w/attached garage	2012
New	Approved basic 11-103615 BP	2009 IRC	Plan# 3019C	2-story sfr w/attached garage	2012
New	Approved basic 11-104259 BP	2009 IRC	Plan# 3015B	2-story sfr w/attached garage	2012
New	Approved basic 11-104260 BP	2009 IRC	Plan#3012B	2-story sfr w/attached garage	2012
New	Approved basic 11-103612 BP	2009 IRC	Plan# 3019A	2-story sfr w/attached garage	2012
New	Approved basic 11-103615 BP	2009 IRC	Plan# 3019C	2-story sfr w/attached garage	2012
New	Approved basic 11-103617 BP	2009 IRC	Plan# 2422A	2-story sfr w/attached garage	2012
New	Approved basic 11-104257 BP	2009 IRC	Plan# 3012A	2-story sfr w/attached garage	2012
New	Approved basic 11-103610 BP	2009 IRC	Plan# 2422B	2-story sfr w/attached garage	2012
New	Approved basic 11-103612 BP	2009 IRC	Plan# 3019A	2-story sfr w/attached garage	2012
New	Approved basic 11-104260 BP	2009 IRC	Plan#3012B	2-story sfr w/attached garage	2012
New	Approved basic 11-103617 BP	2009 IRC	Plan# 2422A	2-story sfr w/attached garage	2012
New	2-story sfr w/attached garage				2012
New	2-story sfr w/attached garage				2012
New	2-story sfr w/attached garage				2012
New	2-story sfr w/attached garage				2012
New	Approved basic 11-103615 BP	2009 IRC	Plan# 3019C	2-story sfr w/attached garage	2012
New	Approved basic 11-104256 BP	2009 IRC	Plan# 3015A	2-story sfr w/attached garage	2012
New	Approved basic 11-104260 BP	2009 IRC	Plan#3012B	2-story sfr w/attached garage	2012
New	Approved basic 10-108468 BP	2009 IRC	Plan# 2801 SW	3-story sfr w/tuck under garage	2012
New	Approved basic 10-108468 BP	2009 IRC	Plan# 2801 SW	3-story sfr w/tuck under garage	2012
New	Approved basic 10-108467 BP	2009 IRC	Plan# 2603 SW	3-story sfr w/tuck under garage	2012
New	Approved basic 11-105359 BP	2009 IRC	Plan# Glacier-B	2-story sfr w/attached garage	2012
New	Approved basic 12-102746 BP	2009 IRC	Plan# Olympic B	2-story sfr w/attached garage	2012
New	Approved basic 10-105930 BP	2009 IRC	Plan# Shaw B	2-story sfr w/attached garage	2012
New	Approved basic 11-105360 BP	2009 IRC	Plan# Cascade-B 3 car	2-story sfr w/attached garage	2012



Accessory Dwelling Units

Index # - File Name: 1.0022 - Single Family Dwellings Data\_Snohomish County.pdf

New	Approved basic 12-100084 BP	2009 IRC	Plan# Baker-B	3-story sfr w/attached garag	2012
New	Approved basic 11-105360 BP	2009 IRC	Plan# Cascade-B 3 car	2-story sfr w/attached ga	2012
New	Approved basic 10-105930 BP	2009 IRC	Plan# Shaw B	2-story sfr w/attached gar	2012
New	Approved basic 11-105359 BP	2009 IRC	Plan# Glacier-B	2-story sfr w/attached gara	2012
New	Approved basic 11-102547 BP	2009 IRC	Plan# Skagit A	2-story sfr w/attached ga	2012
New	Approved basic 10-105528 BP	2009 IRC	Plan # Cypress B	2-story sfr w/attached ga	2012
New	Approved basic 10-108456 BP	2009 IRC	Plan# Shasta II-B	2-story sfr w/attached	2012
New	Approved basic 10-105930 BP	2009 IRC	Plan# Shaw B	2-story sfr w/attached gar	2012
New	Approved basic 10-107477 BP	2009 IRC	Plan# Dayton A	2-story sfr w/attached gara	2012
New	Approved basic 10-108454 BP	2009 IRC	Plan# Hazelwood-B	2-story sfr w/attache	2012
New	Approved basic 10-109011 BP	2009 IRC	Plan# Mansfield A	2-story sfr w/attache	2012
New	Approved basic 10-106958 BP	2009 IRC	Plan# Rainier B	2-story sfr w/attached gar	2012
New	Approved basic 10-107477 BP	2009 IRC	Plan# Dayton A	2-story sfr w/attached gara	2012
New	Approved basic 10-107468 BP	2009 IRC	Plan# 3725-B	2-story sfr w/attached gara	2012
New	Approved basic 10-107465 BP	2009 IRC	Plan# 3722-A	2-story sfr w/attached gara	2012
New	Approved basic 11-100920 BP	2009 IRC	Plan# 3731-A	2-story sfr w/attached gar	2012
New	Approved basic 10-106094 BP	2009 IRC	Plan# 3724-A	2-story sfr w/attached gara	2012
New	Approved basic 12-102527 BP	2009 IRC	Plan# 3732-B	2-story sfr w/attached gar	2012
New	Approved basic 11-100921 BP	2009 IRC	Plan# 3731-B	2-story sfr w/attached	2012
New	Approved basic 10-107462 BP	2009 IRC	Plan# 3720-B	2-story sfr w/attached gara	2012
New	Approved basic 10-107465 BP	2009 IRC	Plan# 3722-A	2-story sfr w/attached gara	2012
New	Approved basic 10-106095 BP	2009 IRC	Plan # 3724-B	2-story sfr w/attached garag	2012
New	Approved basic 10-107466 BP	2009 IRC	Plan# 3722-B	2-story sfr w/attached garage	2012
New	Approved basic 10-107035 BP	2009 IRC	Plan# 3726-A	2-story sfr w/attached g	2012
New	SFR, spit level style with attached two car garage, 5 bedrooms				2012
New	SFR - two story style with attached two car garage (4 bedrooms)				2012
New	Approved basic 12-107557 BP	2009 IRC	Plan# James	Rambler style sfr w/attac	2012
New	Approved basic 12-107553 BP	2009 IRC	Plan# Marvin	2-story sfr w/attached gar	2012
New	Approved basic 12-107553 BP	2009 IRC	Plan# Marvin	2-story sfr w/attached gar	2012
New	Approved basic 12-107556 BP	2009 IRC	Plan# Nate	2-story sfr w/attached g	2012
New	Approved basic 12-107557 BP	2009 IRC	Plan# James	Rambler style sfr w/attac	2012
New	Approved basic 12-107556 BP	2009 IRC	Plan# Nate	2-story sfr w/attached g	2012
New	Approved basic 12-107556 BP	2009 IRC	Plan# Nate	2-story sfr w/attached ga	2012
New	Approved basic 12-107553 BP	2009 IRC	Plan# Marvin	2-story sfr w/attached gar	2012
New	Approved basic 12-107556 BP	2009 IRC	Plan# Nate	2-story sfr w/attached g	2012
New	Rambler style sfr w/attached garage				2012
New	Approved basic 10-107465 BP	2009 IRC	Plan# 3722-A	2-story sfr w/attached gara	2012
New	One time extension granted (1-23-12 to 7-23-13)HFaller. 2story SFR with attached garage - 201				2012
New	One time application extension granted-Application to expire 12-16-2013. Approved basic 10-1				2012
New	One time application extension granted-Application to expire 12-16-2013.Approved basic 10-10				2012
New	One time application extension granted-Application to expire 12-16-2013. Approved basic 10-1				2012
New	One time application extension granted-Application to expire 12-16-2013. Approved basic 10-1				2012
New	3-story sfr w/attached garage				2012
New	SFR, 2 story with attached garage and covered porch				2012
New	2-story sfr w/attached garage				2012
New	2-story sfr w/attached garage				2012
New	2-story sfr w/attached garage				2012

Accessory Dwelling Units

Index # - File Name: 1.0022 - Single Family Dwellings Data\_Snohomish County.pdf

New	2-story sfr w/attached garage				2012
New	2-story sfr w/attached garage				2012
New	2-story sfr w/attached garage				2012
New	2-story sfr w/attached garage				2012
New	2-story sfr w/attached garage				2012
New	Approved basic 12-102746 BP	2009 IRC	Plan# Olympic B	2-story sfr w/attached g	2012
New	Approved basic 12-102820 BP	2009 IRC	Plan# Blakely A	2-story sfr w/attached garag	2012
New	Approved basic 12-102746 BP	2009 IRC	Plan# Olympic B	2-story sfr w/attached g	2012
New	Approved basic 12-100084 BP	2009 IRC	Plan# Baker-B	3-story sfr w/attached garag	2012
New	Approved basic 11-102548 BP	2009 IRC	Plan# Decatur A	3-story sfr w/attache	2012
New	Approved basic 10-107475 BP	2009 IRC	Plan# Franklin B	2-story sfr w/attached	2012
New	Approved basic 11-100307 BP	2009 IRC	Plan# Blakely B-3 car	2-story sfr w/attache	2012
New	Approved basic 11-109775 BP	2009 IRC	Plan# Cascde-A	2-story sfr w/attached ga	2012
New	Approved basic 11-109776 BP	2009 IRC	Plan# San Juan-A	2-story sfr w/attached ;	2012
New	Approved basic 11-109777 BP	2009 IRC	Plan# Sinclair-A	2-story sfr w/attached	2012
New	Approved basic 10-105529 BP	2009 IRC	Plan# Baker A	2-story sfr w/attached gar	2012
New	Approved basic 12-100084 BP	2009 IRC	Plan# Baker-B	3-story sfr w/attached garag	2012
New	Approved basic 10-105538 BP	2009 IRC	Plan# Chelan II A	2-story sfr w/attached ;	2012
New	Approved basic 12-104680 BP	2009 IRC	Plan# Mason-B	2-story sfr w/attache	2012
New	Approved basic 11-105359 BP	2009 IRC	Plan# Glacier-B	2-story sfr w/attached gar	2012
New	Approved basic 10-107171 BP	2009 IRC	Plan# Chellan II-A (3 Car)	2-story sfr w/atta	2012
New	Approved basic 12-100084 BP	2009 IRC	Plan# Baker-B	3-story sfr w/attached garag	2012
New	Approved basic 11-102548 BP	2009 IRC	Plan# Decatur A	3-story sfr w/attache	2012
New	Approved basic 11-102545 BP	2009 IRC	Plan# Barclay A	3-story sfr w/attached ga	2012
New	Approved basic 11-106515 BP	2009 IRC	Plan# Kokanee A	3-story sfr w/tuck under g	2012
New	Approved basic 11-102545 BP	2009 IRC	Plan# Barclay A	3-story sfr w/attached ga	2012
New	Approved basic 11-106512 BP	2009 IRC	Plan# Whatcom A	3-story sfr w/tuck unde	2012
New	Approved basic 11-105360 BP	2009 IRC	Plan# Cascade-B 3 car	2-story sfr w/attached ga	2012
New	Approved basic 12-102820 BP	2009 IRC	Plan# Blakely A	2-story sfr w/attached garag	2012
New	Approved basic 11-105359 BP	2009 IRC	Plan# Glacier-B	2-story sfr w/attached gar	2012
New	Approved basic 11-102545 BP	2009 IRC	Plan# Barclay A	3-story sfr w/attached ga	2012
New	Approved basic 11-102548 BP	2009 IRC	Plan# Decatur A	3-story sfr w/attache	2012
New	Approved basic 11-105854 BP	2009 IRC	Plan# Windom-B	3-story sfr w/attached	2012
New	Approved basic 11-105360 BP	2009 IRC	Plan# Cascade-B 3 car	2-story sfr w/attached ga	2012
New	Approved basic 10-105930 BP	2009 IRC	Plan# Shaw B	2-story sfr w/attached gar	2012
New	2-story sfr w/attached garage				2012
New	2-story sfr w/attached garage				2012
New	2-story sfr w/attached garage				2012
New	Approved basic 11-101753 BP	2009 IRC	Plan# 2533-03AB	2-story sfr w/attached ga	2012
New	Approved basic 11-100555 BP	2009 IRC	Plan# 3310-03AB	2-story sfr w/attached gar	2012
New	Approved basic 11-101753 BP	2009 IRC	Plan# 2533-03AB	2-story sfr w/attached ga	2012
New	Approved basic 11-101362 BP	2009 IRC	Plan# 2950-03AD	2-story sfr w/attached ga	2012
New	Approved basic 12-100408 BP	2009 IRC	Plan# 2808-02AB	2-story sfr w/attached ga	2012
New	Approved basic 11-100763 BP	2009 IRC	Plan# 2462 A	2-story sfr w/attached ga	2012
New	Approved basic 12-100408 BP	2009 IRC	Plan# 2808-02AB	2-story sfr w/attached ga	2012
New	Approved basic 11-100555 BP	2009 IRC	Plan# 3310-03AB	2-story sfr w/attached gar	2012
New	Approved basic 11-100766 BP	2009 IRC	Plan# 2462 B	2-story sfr w/attached gara	2012

Accessory Dwelling Units

Index # - File Name: 1.0022 - Single Family Dwellings Data\_Snohomish County.pdf

New	Approved basic 11-100762 BP	2009 IRC	Plan# 2206 A	2-story sfr w/attached gar	2012
New	Approved basic 11-100766 BP	2009 IRC	Plan# 2462 B	2-story sfr w/attached gara	2012
New	Approved basic 11-100764 BP	2009 IRC	Plan# 2206 B	2-story sfr w/attached ga	2012
New	Approved basic 11-100763 BP	2009 IRC	Plan# 2462 A	2-story sfr w/attached ga	2012
New	Approved basic 11-100765 BP	2009 IRC	Plan # 1993 A	2-story sfr w/attached gar	2012
New	Approved basic 11-100765 BP	2009 IRC	Plan # 1993 A	2-story sfr w/attached gar	2012
New	Approved basic 11-100764 BP	2009 IRC	Plan# 2206 B	2-story sfr w/attached ga	2012
New	Approved basic 11-100763 BP	2009 IRC	Plan# 2462 A	2-story sfr w/attached ga	2012
New	Approved basic 11-100766 BP	2009 IRC	Plan# 2462 B	2-story sfr w/attached gara	2012
New	Approved basic 11-100763 BP	2009 IRC	Plan# 2462 A	2-story sfr w/attached ga	2012
New	Approved basic 11-100764 BP	2009 IRC	Plan# 2206 B	2-story sfr w/attached ga	2012
New	Approved basic 11-100765 BP	2009 IRC	Plan # 1993 A	2-story sfr w/attached gar	2012
New	Approved basic 10-106169 BP	2009 IRC	Plan#2012-02AB-09	2-story sfr w/attachec	2012
New	2-story sfr w/attached garage				2012
New	One-story SFR with attached garage - 2009 IRC				2012
New	Two-story SFR with attached garage - 2009 IRC				2012
New	2-story sfr w/attached garage				2012
New	2 story sfr w/attached garage				2012
New	Rambler style sfr w/attached garage				2012
New	2-story sfr w/attached garage				2012
New	Approved basic 10-108387 BP	2009 IRC	Plan# 2455 B	Rambler style sfr daylight t	2012
New	Approved basic 11-101366 BP	2009 IRC	Plan# 2666A	2-story sfr finished baseme	2012
New	Revision changed basic plan 06-05-2012 jrlind	Approved basic 11-101366 BP	2009 IRC		2012
New	Approved basic 10-106142 BP	2009 IRC	Plan# 2191 B	2-story sfr w/attached garag	2012
New	Approved basic 10-108070 BP	2009 IRC	Plan# 2132 B	2-story sfr w/attached garaj	2012
New	Approved basic 10-106141 BP	2009 IRC	Plan# 2191 A	2-story sfr w/attached garag	2012
New	Approved basic 10-108069 BP	2009 IRC	Plan# 2132 A	2-story sfr w/attached gar	2012
New	Approved basic 10-108069 BP	2009 IRC	Plan# 2132 A	2-story sfr w/attached gar	2012
New	Approved basic 10-108069 BP	2009 IRC	Plan# 2132 A	2-story sfr w/attached gar	2012
New	Approved basic 10-108070 BP	2009 IRC	Plan# 2132 B	2-story sfr w/attached garaj	2012
New	Approved basic 10-108069 BP	2009 IRC	Plan# 2132 A	2-story sfr w/attached gar	2012
New	Approved basic 10-108070 BP	2009 IRC	Plan# 2132 B	2-story sfr w/attached garaj	2012
New	2 story rambler and attached garage				2012
New	Approved basic 10-108069 BP	2009 IRC	Plan# 2433 B	2-story sfr w/attached garaj	2012
New	Approved basic 11-102324 BP	2009 IRC	Plan# 1881	2-story sfr w/attached garage	2012
New	Rambler style sfr w/attached garage				2012
New	Approved basic 10-107756 BP	2009 IRC	Plan# 466-A	2-story sfr w/attached g	2012
New	Approved basic 10-107739 BP	2009 IRC	Plan# 446	2-story sfr w/attached gar	2012
New	Approved basic 11-107949 BP	2009 IRC	Plan# 1825	2-story sfr w/attached garage	2012
New	Approved basic 11-107951 BP	2009 IRC	Plan# 1892	2-story sfr w/attached garag	2012
New	Approved basic 11-107949 BP	2009 IRC	Plan# 1825	2-story sfr w/attached garage	2012
New	Approved basic 10-106169 BP	2009 IRC	Plan#2012-02AB-09	2-story sfr w/attachec	2012
New	Approved basic 10-108379 BP	2009 IRC	Plan# 2472A - 09	2-story sfr w/attached	2012
New	Approved basic 10-106169 BP	2009 IRC	Plan#2012-02AB-09	2-story sfr w/attachec	2012
New	Approved basic 12-100498 BP	2009 IRC	Plan# 2273 A	2-story sfr w/attached gar	2012
New	Approved basic 10-106170 BP	2009 IRC	Plan# 1601-02A-09	2-story sfr w/attachec	2012
New	Approved basic 10-106169 BP	2009 IRC	Plan#2012-02AB-09	2-story sfr w/attachec	2012

Accessory Dwelling Units

Index # - File Name: 1.0022 - Single Family Dwellings Data\_Snohomish County.pdf

New	Approved basic 11-106187 BP	2009 IRC	Plan# 2214 A - 09	2-story sfr w/attached	2012
New	Approved basic 10-108379 BP	2009 IRC	Plan# 2472A - 09	2-story sfr w/attached	2012
New	Approved basic 10-108380 BP	2009 IRC	Plan# 2472 B - 09	2-story sfr w/attached	2012
New	Approved basic 10-106169 BP	2009 IRC	Plan#2012-02AB-09	2-story sfr w/attached	2012
New	Approved basic 10-108379 BP	2009 IRC	Plan# 2472A - 09	2-story sfr w/attached	2012
New	Approved basic 10-106169 BP	2009 IRC	Plan#2012-02AB-09	2-story sfr w/attached	2012
New	Approved basic 10-106170 BP	2009 IRC	Plan# 1601-02A-09	2-story sfr w/attached	2012
New	Approved basic 10-106170 BP	2009 IRC	Plan# 1601-02A-09	2-story sfr w/attached	2012
New	Approved basic 10-106169 BP	2009 IRC	Plan#2012-02AB-09	2-story sfr w/attached	2012
New	Two-story SFR with attached garage - 2009 IRC				2012
New	Two-story SFR with attached garage - 2009 IRC				2012
New	Two-story SFR with attached garage - 2009 IRC				2012
New	Approved basic 10-106689 BP	2009 IRC	Plan# Jupiter	Rambler w/attached garage	2012
New	Approved basic 12-104138BP	2009 IRC	Plan# 3000	2-story sfr w/attached garage	2012
New	Two story SFR with 225 sf unfinished basement and attached garage - 2009 IRC				2012
New	Two-story SFR with attached garage - 2009 IRC				2012
New	1705 sf SFR with 800 sf finished daylight basement and attached garage 2009 IRC				2012
New	Approved basic 10-106689 BP	2009 IRC	Plan# Jupiter	Rambler w/attached garage	2012
New	2-story sfr w/attached garage				2012
New	Approved basic 12-107735 BP	2009 IRC	Plan# 2-30.02E	2-story sfr w/attached	2012
New	Approved basic 12-107729 BP	2009 IRC	Plan# 20-30.02F	2-story sfr w/attached	2012
New	Approved basic 12-109252 BP	2009 IRC	Plan# 19-30.02 C CREEKSTONE	2-story sfr w/a	2012
New	Approved basic 12-109259 BP	2009 IRC	Plan# 2-30.02 A CREEKSTONE	2-story sfr w/a	2012
New	Approved basic 12-107726 BP	2009 IRC	Plan# 19-30.02D	2-story sfr w/attached	2012
New	Approved basic 12-109263 BP	2009 IRC	Plan# 18-30.02 J CREEKSTONE	2-story sfr w/a	2012
New	Approved basic 12-109252 BP	2009 IRC	Plan# 19-30.02 C CREEKSTONE	2-story sfr w/a	2012
New	Approved basic 12-109255 BP	2009 IRC	Plan# 18-30.02 M CREEKSTONE	2-story sfr w/a	2012
New	Approved basic 12-109257 BP	2009 IRC	Plan# 1-40.02 B CREEKSTONE	2-story sfr w/a	2012
New	Approved basic 12-107726 BP	2009 IRC	Plan# 19-30.02D	2-story sfr w/attached	2012
New	Approved basic 12-109258 BP	2009 IRC	Plan# 4-40.02 H CREEKSTONE	2-story sfr w/a	2012
New	Approved basic 12-103588 BP	2009 IRC	Plan# 1640	2-story sfr w/attached garage	2012
New	864sq ft SFR over 864sq ft Garage 2 closet areas and 1 bath tub may extend 24 inches into the				2012
New	Approved basic 12-110563 BP	2009 IRC	Plan# Julia Grande	2-story sfr w/attached	2012
New	Approved basic 12-109465 BP	2009 IRC	Plan# June 1866	Rambler style sfr w/a	2012
New	Approved basic 10-107036 BP	2009 IRC	Plan # 3726-B	2-story sfr w/attached garage	2012
New	Two story home with attached 2 car garage (5 bedrooms)				2012
New	2-story sfr w/attached garage				2012
New	Approved basic 11-104448 BP	2009 IRC	Plan# 2455	2-story sfr w/attached garage	2012
New	2-story sfr w/attached garage				2012
New	Approved basic 11-107393 BP	2009 IRC	Plan# 2381	2-story sfr w/attached garage	2012
New	Approved basic 11-107393 BP	2009 IRC	Plan# 2381	2-story sfr w/attached garage	2012
New	Approved basic 11-104444 BP	2009 IRC	Plan# 2377	2-story sfr w/attached garage	2012
New	Approved basic 12-106363 BP	2009 IRC	Plan# 4240	Rambler style sfr w/attached	2012
New	Approved basic 12-103430 BP	2009 IRC	Plan# 2823	2-story sfr w/attached garage	2012
New	2-story sfr w/attached garage				2012
New	Approved basic 10-103185 BP	2009 IRC	Plan# Westport	2-story daylight w/attached	2012
New	Approved basic 10-103192 BP	2009 IRC	Plan# Hampton	2-story sfr w/attached	2012

Accessory Dwelling Units

Index # - File Name: 1.0022 - Single Family Dwellings Data\_Snohomish County.pdf

New	Approved basic 12-106360 BP	2009 IRC	Plan# 2904	Rambler style sfr w/attache	2012
New	Approved basic 12-103430 BP	2009 IRC	Plan# 2823	2-story sfr w/attached garag	2012
New	Rambler style sfr w/attached garage and bonus room above				2012
New	Rambler style sfr w/attached garage and bonus room above				2012
New	2-story sfr w/attached garage				2012
New	2162 rambler with attached garage - 2009 IRC				2012
New	Approved basic 10-106847 BP	2009 IRC	Plan# 1883 40#	2-story sfr w/attached	2012
New	Approved basic 12-102682 BP	2009 IRC	Plan# 2390 40# Snowload	2-story sfr w/att	2012
New	Revision to issued permit 11-05-2012 jrlind			Rambler style sfr w/attached garage and boi	2012
New	2-story sfr w/attached garage				2012
New	Rambler style sfr w/attached garage				2012
New	Rambler style sfr w/attached garage				2012
New	Rambler style sfr w/attached garage and bonus room above Note: application revised 01-27-20				2012
New	Approved basic 12-106360 BP	2009 IRC	Plan# 2904	Rambler style sfr w/attache	2012
New	Approved basic 12-106479 BP	2009 IRC	Plan# 2923	Rambler style sfr w/attache	2012
New	Approved basic 12-103423 BP	2009 IRC	Plan# 2150	Rambler style sfr w/attache	2012
New	Approved basic 12- 103427 BP	2009 IRC	Plan# 2595	2-story sfr w/attached ga	2012
New	Approved basic 12-103425 BP	2009 IRC	Plan# 2208	2-story sfr w/attached gar	2012
New	Approved basic 12-103430 BP	2009 IRC	Plan# 2823	2-story sfr w/attached garag	2012
New	Approved basic 11-105360 BP	2009 IRC	Plan# Cascade-B 3 car	2-story sfr w/attached ga	2012
New	Approved basic 12-100084 BP	2009 IRC	Plan# Baker-B	3-story sfr w/attached garag	2012
New	Approved basic 11-109056 BP	2009 IRC	Plan# Chamberlain-B	2-story sfr w/attache	2012
New	Approved basic 11-109055 BP	2009 IRC	Plan# Chamberlain-A	2-story sfr w/attache	2012
New	Approved basic 11-109775 BP	2009 IRC	Plan# Cascde-A	2-story sfr w/attached ga	2012
New	Approved basic 10-105529 BP	2009 IRC	Plan# Baker A	2-story sfr w/attached gar	2012
New	Approved basic 10-107171 BP	2009 IRC	Plan# Chellan II-A (3 Car)	2-story sfr w/atta	2012
New	Approved basic 11-102548 BP	2009 IRC	Plan# Decatur A	3-story sfr w/attache	2012
New	Approved basic 11-102545 BP	2009 IRC	Plan# Barclay A	3-story sfr w/attached ga	2012
New	Approved basic 11-105854 BP	2009 IRC	Plan# Windom-B	3-story sfr w/attached	2012
New	Approved basic 11-102545 BP	2009 IRC	Plan# Barclay A	3-story sfr w/attached ga	2012
New	Approved basic 10-103191 BP	2009 IRC	Plan# Richmond	2-story sfr w/attac	2012
New	Application extension granted until June 29, 2013 jrlind Building Q unit 25				2012
New	Application extension granted until June 29, 2013 jrlind Building R unit 53				2012
New	Application extension granted until June 29, 2013 jrlind Building S unit 57				2012
New	Application extension granted until June 29, 2013 jrlind Building T unit 85				2012
New	Application extension granted until June 29, 2013 jrlind Building U unit 21				2012
New	Application extension granted until June 29, 2013 jrlind Building CC unit 89				2012
New	Application extension granted until June 29, 2013 jrlind Building T unit 86				2012
New	Application extension granted until June 29, 2013 jrlind Building T unit 87				2012
New	Application extension granted until June 29, 2013 jrlind Building T unit 88				2012
New	Application extension granted until June 29, 2013 jrlind Building CC unit 90				2012
New	Application extension granted until June 29, 2013 jrlind Building CC unit 91				2012
New	Application extension granted until June 29, 2013 jrlind Building CC unit 92				2012
New	Application extension granted until June 29, 2013 jrlind Building U unit 22				2012
New	Application extension granted until June 29, 2013 jrlind Building U unit 23				2012
New	Application extension granted until June 29, 2013 jrlind Building U unit 24				2012
New	Application extension granted until June 29, 2013 jrlind Building Q unit 26				2012

Accessory Dwelling Units

Index # - File Name: 1.0022 - Single Family Dwellings Data\_Snohomish County.pdf

New	Application extension granted until June 29, 2013	jr lind	Building Q unit 27	2012
New	Application extension granted until June 29, 2013	jr lind	Building Q unit 28	2012
New	Application extension granted until June 29, 2013	jr lind	Building R Unit 54	2012
New	Application extension granted until June 29, 2013	jr lind	Building R Unit 55	2012
New	Application extension granted until June 29, 2013	jr lind	Building R unit 56	2012
New	Application extension granted until June 29, 2013	jr lind	building S unit 58	2012
New	Application extension granted until June 29, 2013	jr lind	Building S unit 59	2012
New	Application extension granted until June 29, 2013	jr lind	Building S unit 60	2012
New	Approved basic 12-101301 BP	2009 IRC	Plan# 1868 3 story sfr w/attached gara	2012
New	Approved basic 11-105561 BP	2009 IRC	Plan# 3431-3 2-story sfr w/attached	2012
New	Approved basic 12-104193 BP	2009 IRC	Plan# Palmer B 3 story sfr w/attached gar	2012
New	Approved basic 12-101301 BP	2009 IRC	Plan# 1868 3 story sfr w/attached gara	2012
New	Approved basic 12-101301 BP	2009 IRC	Plan# 1868 3 story sfr w/attached gara	2012
New	Approved basic 12-101301 BP	2009 IRC	Plan# 1868 3 story sfr w/attached gara	2012
New	Approved basic 10-103612 BP	2009 IRC	Plan# 2370 SW 2-story sfr w/attached garag	2012
New	2-story sfr w/attached garage			2012
New	Approved basic 11-107680 BP	2009 IRC	Plan# 4173-3 2-story w/daylight basement w	2012
New	2-story sfr w/daylight basement w/attached garage			2012
New	Approved basic 11-107680 BP	2009 IRC	Plan# 4173-3 2-story w/daylight basement w	2012
New	Approved basic 11-105561 BP	2009 IRC	Plan# 3431-3 2-story sfr w/attached	2012
New	2-story sfr w/attached garage			2012
New	2-story sfr w/attached garage			2012
New	2-story sfr w/attached garage			2012
New	Approved basic 11-105561 BP	2009 IRC	Plan# 3431-3 2-story sfr w/attached	2012
New	2-story sfr w/attached garage			2012
New	Approved basic 12-110207 BP	2009 IRC	Plan#3540-3 2-story sfr w/attached garage	2012
New	Approved basic 11-105561 BP	2009 IRC	Plan# 3431-3 2-story sfr w/attached	2012
New	2-story sfr w/attached garage			2012
New	2-story sfr w/attached garage			2012
New	2-story sfr w/attached garage			2012
New	Approved basic 11-105561 BP	2009 IRC	Plan# 3431-3 2-story sfr w/attached	2012
New	Approved basic 12-106018 BP	2009 IRC	Plan# 3138 2-story sfr w/attached garage	2012
New	Approved basic 12-103588 BP	2009 IRC	Plan# 1640 2-story sfr w/attached garage	2012
New	Approved basic 12-103588 BP	2009 IRC	Plan# 1640 2-story sfr w/attached garage	2012
New	Approved basic 12-103589 BP	2009 IRC	Plan# 1510 Rambler style sfr w/attached	2012
New	Approved basic 11-104779 BP	2009 IRC	Plan# 1468 Rambler style sfr w/attached ga	2012
New	Approved basic 12-103589 BP	2009 IRC	Plan# 1510 Rambler style sfr w/attached	2012
New	Approved Basic 10-106196 BP	2009 IRC	Plan # 1409 Rambler SFR w/attached 3-car g	2012
New	Approved basic 12-103416BP	2009 IRC	Plan# 1850 - 2-story 2-story sfr w/attach	2012
New	Approved basic 11-104779 BP	2009 IRC	Plan# 1468 Rambler style sfr w/attached ga	2012
New	Approved basic 12-103589 BP	2009 IRC	Plan# 1510 2-story sfr w/attached garag	2012
New	Approved basic 12-108643 BP	2009 IRC	Plan# 2777 2-story sfr w/attached gara	2012
New	Approved basic 12-100357 BP	2009 IRC	Plan# 2279-30-8 2-story sfr w/attached ga	2012
New	Approved basic 12-108641 BP	2009 IRC	Plan# 2557 2-story sfr w/attached gara	2012
New	Approved basic 12-108642 BP	2009 IRC	Plan# 2102 2-story sfr w/attached garag	2012
New	Approved basic 12-108643 BP	2009 IRC	Plan# 2777 2-story sfr w/attached gara	2012

Accessory Dwelling Units

Index # - File Name: 1.0022 - Single Family Dwellings Data\_Snohomish County.pdf

New	Approved basic 12-108641 BP	2009 IRC	Plan# 2557	2-story sfr w/attached gara	2012
New	Approved basic 12-100046	2009 IRC	Plan# 1875-30-8	2-storys sfr w/attached gara	2012
New	Approved basic 12-103588 BP	2009 IRC	Plan# 1640	2-story sfr w/attached garage	2012
New	Approved basic 10-109013 BP	2009 IRC	Plan# Granite A	2-story sfr w/attached ga	2012
New	Approved basic 10-105931 BP	2009 IRC	Plan# Shasta II-A	2-story sfr w/attached garage	2012
New	Approved basic 10-108454 BP	2009 IRC	Plan# Hazelwood-B	2-story sfr w/attached	2012
New	Approved basic 11-107397 BP	2009 IRC	Plan# Wrangell A	2-story sfr w/attache	2012
New	2-story sfr w/attached garage				2012
New	Approved basic 11-105568 BP	2009 IRC	Plan# 2280	2-story sfr w/attached garag	2012
New	Approved basic 11-105566 BP	2009 IRC	Plan# 2420	2-story sfr w/attached garag	2012
New	Approved basic 12- 103427 BP	2009 IRC	Plan# 2595	2-story sfr w/attached ga	2012
New	Two story home with unfinished daylight basement, covered front porch and attached 3 car gar				2012
New	Rambler style sfr w/attached garage				2012
New	Rambler style sfr w/attached garage				2012
New	Rambler style w/attached garage				2012
New	Rambler style sfr w/attached garage				2012
New	2-storys fr w/attached garage				2012
New	Approved basic 10-105501 BP	2009 IRC	Plan# 2186	Rambler w/attached gara	2012
New	Approved basic 10-109367 BP	2009 IRC	Plan# 2453	Rambler style sfr w/attached g	2012
New	Approved basic 10-105501 BP	2009 IRC	Plan# 2186	Rambler w/attached gara	2012
New	Approved basic 10-109367 BP	2009 IRC	Plan# 2453	Rambler style sfr w/attached g	2012
New	Approved basic 12-103656 BP	2009 IRC	Plan# 2297	2-story sfr w/attached garage	2012
New	Approved basic 10-106515 BP	2009 IRC	Plan# 2664	2-story sfr w/attached gara	2012
New	Approved basic 12-103657 BP	2009 IRC	Plan# 1933	Rambler w/attached garage	2012
New	Approved basic 10-107478 BP	2009 IRC	Plan# Jameson A	2-story sfr w/attached g	2012
New	Approved basic 10-109258 BP	2009 IRC	Plan# Evans II A	2-story sfr w/attached ga	2012
New	Approved basic 12-100457 BP	2009 IRC	Plan# Jameson-B	2-story sfr w/attached gara	2012
New	Approved basic 10-109258 BP	2009 IRC	Plan# Evans II A	2-story sfr w/attached ga	2012
New	Approved basic 10-107478 BP	2009 IRC	Plan# Jameson A	2-story sfr w/attached g	2012
New	Approved basic 12-106487 BP	2009 IRC	Plan# 2435 unfinished basement	2-story sf	2012
New	Approved basic 11-102512 BP	2009 IRC	Plan# 3148 db	Rambler daylight basemen	2012
New	Approved basic 12-106487 BP	2009 IRC	Plan# 2435 unfinished basement	2-story sfr	2012
New	2-story sfr w/attached garage				2012
New	2-story sfr w/attached garage				2012
New	2-story sfr w/attached garage				2012
New	Rambler style sfr w/attached garage				2012
New	Rambler style sfr w/attached garage				2012
New	Rambler style sfr w/attached garage				2012
New	Rambler style sfr w/attached garage				2012
New	Rambler style sfr w/attached garage				2012
New	Approved basic 12-100457 BP	2009 IRC	Plan# Jameson-B	2-story sfr w/attached gara	2012
New	Approved basic 10-109014 BP	2009 IRC	Plan# Jefferson A	2-story sfr w/attached	2012
New	Approved basic 12-100085 BP	2009 IRC	Plan# Selkirk-B	2-story sfr w/attached ga	2012
New	Approved basic 11-103159 BP	2009 IRC	Plan# 1803	2-story sfr w/attached gara	2012
New	Approved basic 10-108189 BP	2009 IRC	Plan# 4710-A	2-story sfr w/attached gara	2012
New	Approved basic 10-107035 BP	2009 IRC	Plan# 3726-A	2-story sfr w/attached g	2012
New	Approved basic 10-108190 BP	2009 IRC	Plan# 4710-B	2-story sfr w/attached gara	2012

Accessory Dwelling Units

Index # - File Name: 1.0022 - Single Family Dwellings Data\_Snohomish County.pdf

New	Approved basic 11-102895 BP	2009 IRC	Plan# 3727-B	2-story sfr w/attached gara	2012
New	Approved basic 10-107036 BP	2009 IRC	Plan # 3726-B	2-story sfr w/attached garage	2012
New	Approved basic 11-102894 BP	2009 IRC	Plan# 3727-A	2-story sfr w/attached gara	2012
New	Approved basic 10-108190 BP	2009 IRC	Plan# 4710-B	2-story sfr w/attached gara	2012
New	Approved basic 10-107035 BP	2009 IRC	Plan# 3726-A	2-story sfr w/attached g	2012
New	Approved basic 10-108189 BP	2009 IRC	Plan# 4710-A	2-story sfr w/attached gara	2012
New	Approved basic 11-102895 BP	2009 IRC	Plan# 3727-B	2-story sfr w/attached gara	2012
New	Approved basic 10-108190 BP	2009 IRC	Plan# 4710-B	2-story sfr w/attached gara	2012
New	Approved basic 10-106095 BP	2009 IRC	Plan # 3724-B	2-story sfr w/attached garag	2012
New	Approved basic 11-104995 BP	2009 IRC	Plan# B720-B	2-story sfr w/attached garage	2012
New	2-story sfr w/attached garage				2012
New	Approved basic 11-102301 BP	2009 IRC	Plan# B725-B	2-story sfr w/attached gar	2012
New	2-story sfr w/attached garage				2012
New	2-story sfr w/attached garage				2012
New	Two-story SFR with attached garage - 2009 IRC				2012
New	2-story sfr w/attached garage				2012
New	2-story sfr w/attached garage				2012
New	2-story sfr w/attached garage				2012
New	2-story sfr w/attached garage				2012
New	2-story sfr w/attached garage				2012
New	2- story sfr w/attached garage and unfinished basement				2012
New	2-story sfr w/attached garage				2012
New	Rambler style sfr w/daylight basement w/attached garage				2012
New	Rambler style sfr w/daylight basement w/attached garage				2012
New	2-story sfr w/attached garage				2012
New	2-story sfr w/attached garage				2012
New	Two-story SFR with attached garage - 2009 IRC				2012
New	2-story sfr w/attached garage				2012
New	Rambler style sfr w/daylight basement w/attached garage				2012
New	2-story sfr w/attached garage				2012
New	2-story sfr w/attached garage				2012
New	2-story sfr w/attached garage				2012
New	2-story sfr w/attached garage				2012
New	2-story sfr w/attached garage				2012
New	2-story sfr w/attached garage				2012
New	2-story sfr w/attached garage				2012
New	2-story sfr w/attached garage				2012
New	2-story sfr w/attached garage				2012
New	2-story sfr w/attached garage				2012
New	2-story sfr w/attached garage				2012
New	2-story sfr w/attached garage				2012
New	2-story sfr w/attached garage				2012
New	2-story sfr w/attached garage				2012
New	2-story sfr w/attached garage				2012
New	2-story sfr w/attached garage				2012
New	2-story sfr w/attached garage				2012
New	Two-story SFR with attached garage - 2009 IRC Engineer				2012
New	2-story sfr w/attached garage				2012
New	2-story sfr w/attached garage				2012
New	2-story sfr w/attached garage Applicant had ro remove foundation & walls because it was to cl				2012



Accessory Dwelling Units

Index # - File Name: 1.0022 - Single Family Dwellings Data\_Snohomish County.pdf

New	2-story sfr w/attached garage					2012
New	2-story sfr w/attached garage					2012
New	2-story sfr w/attached garage					2012
New	2-story sfr w/attached garage					2012
New	Two story SFR with attached garage - 2009 IRC	Engineerd by				2012
New	2-story sfr w/attached garage					2012
New	2-story sfr w/attached garage					2012
New	2-story sfr w/attached garage					2012
New	Two-story SFR with attached garage - 2009 IRC	Plan #1629 B	Engineered by			2012
New	2-story sfr w/attached garage					2012
New	2-story sfr w/attached garage					2012
New	2-story sfr w/attached garage					2012
New	2-story sfr w/attached garage					2012
New	Two-story SFR with attached garage - 2009 IRC	Engineer				2012
New	2-story sfr w/attached garage					2012
New	2-story sfr w/attached garage w/daylight basement					2012
New	Approved basic 11-102300	2009 IRC	Plan# B725-A	2-story sfr w/attached gara		2012
New	2-story sfr w/attached garage					2012
New	2-story sfr w/attached garage					2012
New	2-story sfr w/attached garage					2012
New	Approved basic 10-107036 BP	2009 IRC	Plan # 3726-B	2-story sfr w/attached garage		2012
New	Approved basic 11-100921 BP	2009 IRC	Plan# 3731-B	2-story sfr w/attached g		2012
New	Approved basic 12-103206 BP	2009 IRC	Plan# 3725W-B	2-story sfr w/attache		2012
New	Approved basic 10-106093 BP	2009 IRC	Plan# 3723-AB	2-story sfr w/attached garag		2012
New	Approved basic 10-108189 BP	2009 IRC	Plan# 4710-A	2-story sfr w/attached gara		2012
New	Approved basic 10-107036 BP	2009 IRC	Plan # 3726-B	2-story sfr w/attached garage		2012
New	Approved basic 10-108190 BP	2009 IRC	Plan# 4710-B	2-story sfr w/attached gara		2012
New	Approved basic 10-107468 BP	2009 IRC	Plan# 3725-B	2-story sfr w/attached gara		2012
New	Approved basic 11-100921 BP	2009 IRC	Plan# 3731-B	2-story sfr w/attached g		2012
New	Approved basic 10-108190 BP	2009 IRC	Plan# 4710-B	2-story sfr w/attached gara		2012
New	Approved basic 10-107035 BP	2009 IRC	Plan# 3726-A	2-story sfr w/attached g		2012
New	Approved basic 11-102894 BP	2009 IRC	Plan# 3727-A	2-story sfr w/attached gara		2012
New	Approved basic 10-107461 BP	2009 IRC	Plan# 3720-A	2-story sfr w/attached gara		2012
New	Approved basic 12-107463 BP	2009 IRC	Plan# B732-A	2-story sfr w/attached g		2012
New	Approved basic 11-102301 BP	2009 IRC	Plan# B725-B	2-story sfr w/attached gai		2012
New	Approved basic 10-107462 BP	2009 IRC	Plan# 3720-B	2-story sfr w/attached gara		2012
New	REVISION 10-29-2012 jrlind	Approved basic 11-102300	2009 IRC	Plan# B725-A		2012
New	Approved basic 11-104995 BP	2009 IRC	Plan# B720-B	2-story sfr w/attached garage		2012
New	Approved basic 12-107465 BP	2009 IRC	Plan# B732-B	2-story sfr w/attached g		2012
New	Approved basic 11-104994 BP	2009 IRC	Plan# B720-A	2-story sfr w/attached gar		2012
New	Approved basic 11-100918 BP	2009 IRC	Plan# 3707-B	Rambler style sfr w/attached		2012
New	Approved basic 11-100921 BP	2009 IRC	Plan# 3731-B	2-story sfr w/attached g		2012
New	Approved basic 10-108190 BP	2009 IRC	Plan# 4710-B	2-story sfr w/attached gara		2012
New	Approved basic 10-107035 BP	2009 IRC	Plan# 3726-A	2-story sfr w/attached g		2012
New	Approved basic 11-100920 BP	2009 IRC	Plan# 3731-A	2-story sfr w/attached gai		2012
New	Approved basic 11-102894 BP	2009 IRC	Plan# 3727-A	2-story sfr w/attached gara		2012
New	Approved basic 11-100917 BP	2009 IRC	Plan\$ 3707-A	Rambler style sfr w/attached g		2012

Accessory Dwelling Units

Index # - File Name: 1.0022 - Single Family Dwellings Data\_Snohomish County.pdf

New	Approved basic 10-107461 BP	2009 IRC	Plan# 3720-A	2-story sfr w/attached gara	2012
New	Approved basic 10-106093 BP	2009 IRC	Plan# 3723-AB	2-story sfr w/attached garag	2012
New	2-story sfr w/attached garage				2012
New	Approved basic 10-107462 BP	2009 IRC	Plan# 3720-B	2-story sfr w/attached gara	2012
New	Two-story SFR with 709 sf finished basement - 2009 IRC				2012
New	2-story sfr w/daylight basement w/attached garage				2012
New	Rambler w/daylight basement w/attached garage				2012
New	Two-story SFR with 770 sf finished basement -2009 IRC				2012
New	2-story sfr w/attached garage				2012
New	2-story sfr w/attached garage				2012
New	Two story SFR with 988 sf finished basement and attached garage - 2009 IRC				2012
New	2-story sfr w/attached garage				2012
New	2-story sfr w/attached garage				2012
New	Rambler style sfr w/attached garage				2012
New	2-story sfr w/attached garage				2012
New	2-story sfr w/attached garage				2012
New	2-story sfr w/attached garage				2012
New	2-story sfr w/attached garage				2012
New	Rambler w/daylight w/attached garage				2012
New	Two-story SFR with attached garage - 2009 IRC				2012
New	Two-story SFR with attached garage - 2009 IRC				2012
New	2-story sfr w/attached garage				2012
New	Rambler style sfr w/daylight basement w/attached garage				2012
New	Rambler style sfr w/attached garage				2012
New	2-story sfr w/attached garage				2012
New	Approved basic 12-100659 BP	2009 IRC	Plan# 2901	2-story sfr w/attached gar	2012
New	2-story Single Family Residence w/garage and finished basement ****permit transfered from F				2012
New	Approved basic 12-103897BP	2009 IRC	Plan# 2774	2-story sfr w/attached gara	2012
New	Approved basic 12-103897BP	2009 IRC	Plan# 2774	2-story sfr w/attached gara	2012
New	Approved basic 12-103896 BP	2009 IRC	Plan# 2607	2-story sfr w/attached	2012
New	Approved basic 12-103896 BP	2009 IRC	Plan# 2607	2-story sfr w/attached	2012
New	Approved basic 12-103897BP	2009 IRC	Plan# 2774	2-story sfr w/attached gara	2012
New	Approved basic 12-104575 BP	2009 IRC	Plan# 3102	2-story sfr w/attached gara	2012
New	Approved basic 12-104573 BP	2009 IRC	Plan# 2814	2-story sfr w/attached gara	2012
New	Approved basic 12-104575 BP	2009 IRC	Plan# 3102	2-story sfr w/attached gara	2012
New	Approved basic 12-103898BP	2009 IRC	Plan# 2588	2-story sfr w/attached garag	2012
New	Approved basic 12-103896 BP	2009 IRC	Plan# 2607	2-story sfr w/attached	2012
New	Approved basic 12-103898BP	2009 IRC	Plan# 2588	2-story sfr w/attached garag	2012
New	Approved basic 12-103896 BP	2009 IRC	Plan# 2607	2-story sfr w/attached	2012
New	Approved basic 12-103898BP	2009 IRC	Plan# 2588	2-story sfr w/attached garag	2012
New	Approved basic 10-108071 BP	2009 IRC	Plan# 1472	Ramber style w/attached gara	2012
New	Approved basic 10-106144 BP	2009 IRC	Plan# 2064 A	2-story sfr w/attached gara	2012
New	Approved basic 10-106154 BP	2009 IRC	Plan# 1935 B	2-story sfr w/attached garage	2012
New	Approved basic 12-103896 BP	2009 IRC	Plan# 2607	2-story sfr w/attached	2012
New	2-story sfr w/attached garage				2012
New	Approved basic 11-102290 BP	2009 IRC	Plan# 2268-02AB	2-story sfr w/attached	2012
New	Rambler sfr w/attached garage				2012

Accessory Dwelling Units

Index # - File Name: 1.0022 - Single Family Dwellings Data\_Snohomish County.pdf

New	Rambler style sfr w/attached garage				2012
New	2-story sfr w/attached garage				2012
New	2-story sfr w/attached garage				2012
New	Approved basic 12-104440 BP	2009 IRC	Plan# 2146	2-story sfr w/attached garag	2012
New	Approved basic 11-101566 BP	2009 IRC	Plan# Juno A	Rambler w/attached garage	2012
New	Approved Basic 10-107346 BP	2009 IRC	Plan# 2120-02A	2-story sfr w/attached	2012
New	Two story home with attached 2 car garage ( 3 bedrooms )				2012
New	Approved Basic 10-107346 BP	2009 IRC	Plan# 2120-02A	2-story sfr w/attached	2012
New	Approved basic 11-104699 BP	2009 IRC	Plan# 2408-02A	3-story sfr w/attached g	2012
New	Approved basic 10-108456 BP	2009 IRC	Plan# Shasta II-B	2-story sfr w/attached	2012
New	Approved basic 10-108452 BP	2009 IRC	Plan # Langley II-A	2-story sfr w/attached	2012
New	Approved basic 10-109014 BP	2009 IRC	Plan# Jefferson A	2-story sfr w/attached	2012
New	Approved basic 12-103810 BP	2009 IRC	Plan# Granite B	2-story sfr w/attache	2012
New	Approved basic 10-107478 BP	2009 IRC	Plan# Jameson A	2-story sfr w/attached g	2012
New	Approved basic 10-109013 BP	2009 IRC	Plan# Granite A	2-story sfr w/attached ga	2012
New	Approved basic 11-109056 BP	2009 IRC	Plan# Chamberlain-B	2-story sfr w/attache	2012
New	2-story sfr w/attached garage				2012
New	Rambler style sfr w/attached garage				2012
New	Rambler style sfr w/attached garage				2012
New	Approved basic 12-102682 BP	2009 IRC	Plan# 2390 40# Snowload	2-story sfr w/att	2012
New	Two Story SFR with Attached Garage				2012
New	2-story sfr w/attached garage				2012
New	2-story sfr w/attached garage				2012
New	2-story sfr w/attached garage				2012
New	2-story sfr w/attached garage				2012
New	2-story sfr w/attached garage				2012
New	Two-story SFR with attached garage	2009 IRC	Plan: Hawthorne		2012
New	2-story sfr w/attached garage				2012
New	2-story sfr w/attached garage				2012
New	2-story sfr w/attached garage				2012
New	2-story sfr w/attached garage				2012
New	2-story sfr w/attached garage				2012
New	2-story sfr w/attached garage				2012
New	2-story sfr w/attached garage				2012
New	2-story sfr w/attached garage				2012
New	2-story sfr w/attached garage				2012
New	2-story sfr w/attached garage				2012
New	2-story sfr w/attached garage				2012
New	2-story sfr w/attached garage				2012
New	2-story sfr w/attached garage				2012
New	Two-story SFR with attached garage - 2009 IRC		Plan: Hawthorne		2012
New	2-story sfr w/attached garage				2012
New	2-story sfr w/attached garage				2012
New	2-story sfr w/attached garage*****Elevation change 09-20-2012 jlirnd*****				2012
New	2-story sfr w/attached garage				2012
New	2-story sfr w/attached garage				2012
New	2-story sfr w/attached garage				2012
New	2-story sfr w/attached garage				2012

Accessory Dwelling Units

Index # - File Name: 1.0022 - Single Family Dwellings Data\_Snohomish County.pdf

New	2 story sfr w/attached garage *****Elevation change 09-20-2012 jlrind*****				2012
New	2- story sfr w/attached garage				2012
New	2-story sfr w/attached garage				2012
New	2-story sfr w/attached garage				2012
New	2-story sfr w/attached garage				2012
New	2-story sfr w/attached garage				2012
New	Permit transfered to J & S Development LLC. 05-07-2013 jlrind	Approved basic	12-109419		2012
New	Approved basic 12-104440 BP	2009 IRC	Plan# 2146	2-story sfr w/attached garag	2012
New	Rambler style home with attached 3 car garage (4 bedroom)				2012
New	Approved basic 12-109465 BP	2009 IRC	Plan# June 1866	Rambler style sfr w/i	2012
New	Approved basic 10-106693 BP	2009 IRC	Plan# Julia	2-story sfr w/attached garage	2012
New	Approved basic 12-109466 BP	2009 IRC	Plan # Jupiter 2005	2-story sfr w/attach	2012
New	SFR rambler style with attached garage				2012
New	Approved basic 11-101753 BP	2009 IRC	Plan# 2533-03AB	2-story sfr w/attached ga	2012
New	Approved basic 11-100555 BP	2009 IRC	Plan# 3310-03AB	2-story sfr w/attached gar	2012
New	Approved basic 12-103034 BP	2009 IRC	Plan# 2788-02AB	2-story sfr w/attached ga	2012
New	Approved basic 12-100077 BP	2009 IRC	Plan# 2601-02AB	2-story sfr w/attached g	2012
New	Approved basic 11-109347 BP	2009 IRC	Plan# 2083-02AB	2-story sfr w/attached gara	2012
New	Approved basic 12-101123 BP	2009 IRC	Plan# 2245-02A	2-story sfr w/attached gara	2012
New	Approved basic 11-101753 BP	2009 IRC	Plan# 2533-03AB	2-story sfr w/attached ga	2012
New	Approved basic 12-104394 BP	2009 IRC	Plan#	2-story sfr w/attached garage	2012
New	Approved basic 11-100554 BP	2009 IRC	Plan# 2763-03AB	2-story sfr w/attached ga	2012
New	Approved basic 11-106405 BP	2009 IRC	Plan# 2357-02A	2-story sfr w/attached gara	2012
New	Approved basic 11-106406 BP	2009 IRC	Plan# 2357-02B	2-story sfr w/attached ga	2012
New	Approved basic 12-104394 BP	2009 IRC	Plan#	2-story sfr w/attached garage	2012
New	Approved basic 12-104394 BP	2009 IRC	Plan#	2-story sfr w/attached garage	2012
New	Approved basic 12-106030 BP	2009 IRC	Plan# 1984	2-story sfr w/attached gara	2012
New	Revised permit 11-07-2012 jlrind	Approved basic	12-106031 BP	2009 IRC	P
New	Approved basic 12-106030 BP	2009 IRC	Plan# 1894	2-story sfr w/attached gara	2012
New	Approved basic 12-106031 BP	2009 IRC	Plan# 1975	2-story sfr w/attached gar	2012
New	new SFR				2012
New	SFR - rambler with attached 3 car garage and covered porches				2012
New	Approved basic 10-106689 BP	2009 IRC	Plan# Jupiter	Rambler w/attached garage	2012
New	1 time extension granted. Application to expire August 26, 2012. HF			Two-story residence with	2012
New	1 time extension granted. Application to expire August 14, 2012. HF			Two-story SFR with attach	2012
New	2-story sfr no garage				2012
New	Approved basic 11-104347 BP	2009 IRC	Plan#1189-0 A&B	2-story sfr w/attache	2012
New	Approved basic 11-107174 BP	2009 IRC	Plan# 1185-6	2-story sfr w/attached gar	2012
New	2-story sfr w/attached garage				2012
New	Approved basic 12-104456 BP	2009 IRC	Plan# 1185-6	2-story sfr w/attached ga	2012
New	Approved basic 12-105448 BP	2009 IRC	Plan# 1186-0	2-story sfr w/attached gara	2012
New	2-story sfr w/attached garage				2012
New	2-story sfr w/attached garage				2012
New	Approved basic 12-104456 BP	2009 IRC	Plan# 1185-6	2-story sfr w/attached ga	2012
New	Approved basic 12-105448 BP	2009 IRC	Plan# 1186-0	2-story sfr w/attached gara	2012
New	2-story sfr w/attached garage				2012
New	2121sq ft SFR with 744 sq ft Unfinished Basement and 800 sq ft Attached Garage				2012

Accessory Dwelling Units

Index # - File Name: 1.0022 - Single Family Dwellings Data\_Snohomish County.pdf

New	Approved basic 12-100357 BP	2009 IRC	Plan# 2279-30-8	2-story sfr w/attached ga	2012
New	Approved basic 12-100046	2009 IRC	Plan# 1875-30-8	2-storys sfr w/attached gar	2012
New	Approved basic 12-100357 BP	2009 IRC	Plan# 2279-30-8	2-story sfr w/attached ga	2012
New	Approved basic 11-104256 BP	2009 IRC	Plan# 3015A	2-story sfr w/attached garage	2012
New	Approved basic 12-103002 BP	2009 IRC	Plan# 3019 A Revised	2-story sfr w/attach	2012
New	Approved basic 11-103615 BP	2009 IRC	Plan# 3019C	2-story sfr w/attached gar	2012
New	Approved basic 11-103617 BP	2009 IRC	Plan# 2422A	2-story sfr w/attached gar	2012
New	Approved basic 11-104256 BP	2009 IRC	Plan# 3015A	2-story sfr w/attached garage	2012
New	Two story style home with attached garage and covered patio Engineered by Todd T. Rowell, P.E				2012
New	new SFR Engineered by Frank T. Jarnot, P.E. 25746				2012
New	Two Story SFR with Finished Basement and Attached Garage				2012
New	Ramber style sfr w/attached garage				2012
New	Approved basic 12-105597 BP	2009 IRC	Plan# 629 AB	2-story sfr w/attached garage	2012
New	Approved basic 12-105597 BP	2009 IRC	Plan# 629 AB	2-story sfr w/attached garage	2012
New	Approved basic 12-105597 BP	2009 IRC	Plan# 629 AB	2-story sfr w/attached garage	2012
New	Approved basic 12-105597 BP	2009 IRC	Plan# 629 AB	2-story sfr w/attached garage	2012
New	Approved basic 12-105597 BP	2009 IRC	Plan# 629 AB	2-story sfr w/attached garage	2012
New	Approved basic 12-105597 BP	2009 IRC	Plan# 629 AB	2-story sfr w/attached garage	2012
New	2-story sfr w/attached garage				2012
New	Approved basic 12-106602 BP	2009 IRC	Plan# New Lab	2-story sfr w/attachec	2012
New	Approved basic 12-104439 BP	2009 IRC	Plan# Harlequin	2-story sfr w/attac	2012
New	Approved basic 12-103562 BP	2009 IRC	Plan# 2240	2-story sfr w/attached garage	2012
New	Approved basic 12-103562 BP	2009 IRC	Plan# 2240	2-story sfr w/attached garage	2012
New	Approved basic 11-103874 BP	2009 IRC	Plan# 2104	2-story sfr w/attached gara	2012
New	Approved basic 11-103874 BP	2009 IRC	Plan# 2104	2-story sfr w/attached gara	2012
New	Approved basic 11-103874 BP	2009 IRC	Plan# 2104	2-story sfr w/attached gara	2012
New	Approved basic 12-103286 BP	2009 IRC	Plan# 1710	2-story sfr w/attached gara	2012
New	Approved basic 12-103286 BP	2009 IRC	Plan# 1710	2-story sfr w/attached gara	2012
New	Approved basic 12-103286 BP	2009 IRC	Plan# 1710	2-story sfr w/attached gara	2012
New	Approved basic 12-103286 BP	2009 IRC	Plan# 1710	2-story sfr w/attached gara	2012
New	Approved basic 10-106689 BP	2009 IRC	Plan# Jupiter	Rambler w/attached garage	2012
New	2242 sf rambler-style SFR with attached garage - 2009 IRC				2012
New	Approved basic 12-100046	2009 IRC	Plan# 1875-30-8	2-storys sfr w/attached gar	2012
New	Approved basic 12-100357 BP	2009 IRC	Plan# 2279-30-8	2-story sfr w/attached g	2012
New	Approved basic 12-100046	2009 IRC	Plan# 1875-30-8	2-storys sfr w/attached gar	2012
New	Approved basic 12-100357 BP	2009 IRC	Plan# 2279-30-8	2-story sfr w/attached ga	2012
New	Approved basic 12-100046	2009 IRC	Plan# 1875-30-8	2-storys sfr w/attached gar	2012
New	2 story sfr w/attached garage				2012
New	Approved basic 11-103731 BP	2009 IRC	Plan# Parrington	2-story sfr w/attached g	2012
New	Approved basic 11-105568 BP	2009 IRC	Plan# 2280	2-story sfr w/attached garag	2012
New	Approved basic 11-105566 BP	2009 IRC	Plan# 2420	2-story sfr w/attached garag	2012
New	Approved basic 11-105567 BP	2009 IRC	Plan# 2564	2-story sfr w/attached gara	2012
New	Approved basic 12-104138BP	2009 IRC	Plan# 3000	2-story sfr w/attached garag	2012
New	Two-story SFR with attached garage - 2009 IRC				2012
New	2-story sfr w/attached garage				2012
New	2-story sfr w/attached garage				2012
New	2-story sfr w/attached garage				2012

Accessory Dwelling Units

Index # - File Name: 1.0022 - Single Family Dwellings Data\_Snohomish County.pdf

New	Approved basic 11-103731 BP	2009 IRC	Plan# Parrington	2-story sfr w/attached g	2012
New	Two-story SFR - 2009 IRC				2012
New	Approved basic 11-105567 BP	2009 IRC	Plan# 2564	2-story sfr w/attached gara	2012
New	Rambler style sfr w/daylight basement w/attached garage				2012
New	2-story SFR with unfinished basement and garage				2012
New	Single family residence, rambler style, with wrap around deck				2012
New	2 story sfr w/attached garage				2012
New	SFR, two story style home with attached 3 car garage and covered porch (front and back)				2012
New	Application extension granted until June 11, 2013 Proposed 3 story single family residence.				2012
New	Two-story SFR with attached carport - 2006 IRC				2012
New	Split level home with attached garage and covered porch (front and back) 5 bedrooms				2012
New	SFR, 2 story with basement and attached garage				2012
New	Two-story SFR with attached garage - 2009 IRC				2012
New	SFR - two story style with attached 3 car garage (4 bedrooms)				2012
New	2-story sfr w/attached garage				2012
New	Two-story SFR with attached garage - 2009 IRC				2012
New	Two Story SFR with Attached 3 Car Garage				2012
New	SFR - 2 story style home with attached 3 car garage, 4 bedroom, bonus room, den, loft and cove				2012
New	Two story style home with attached garage				2012
New	2-story sfr w/attached garage (aka Building A on site plan).				2012
New	Conversion of garage under construction 09-106738 AB to Single family residence				2012
New	30ft x 68ft 2013 Kit / Stonebridge Mobile Home				2012
New	27 x 56 2012 Marlette Mobile Home				2012
New	install new MH in Mariner Village MHP				2012
New	Two story home with attached garage and covered porch (4 bedrooms)				2012
New	Rambler style House with Detached garage				2012
New	2880 sf rambler with attached garage - 2009 IRC				2012
New	New MH. See 12-106678-LDA				2012
New	SFR, two story with attached garage and covered front porch				2012
New	SFR - Rambler style home with attached 3 car garage See David Huson before approving the Fir				2012
New	840 sq ft Detached Accessory Apartment				2012
New	1014 sf sfr over garage with 285 sf loft - 2009 IRC				2012
New	Duplex - rambler style with attached 2 car garages				2012
New	Demolish old SFR and construct new SFR.				2012
New	1991 14 x 60 Broadmore				2012
New	504 sf detached accessory apartment				2012
New	2265sq ft SFR with 768sq ft Garage				2012
New	Two-story SFR with attached garage - 2009 IRC				2012
New	SFR, Pan Abode Cedar Home, Rambler style home w/ 2nd floor loft, attached 2 car garage and u				2012
New	Mobile home 2012 Marletta, (used as an accessory apartment)				2012
New	Extended to 6/30/14 to obtain final inspection (org expire date 6/11/14) dm 844 sf detached ac				2012
New	Tear down existing SFR to foundation and construct new larger SFR and attached garage.Also de				2012
New	Approved basic 12-104782 BP	2009 IRC	Plan# IN2012	2-story sfr w/attache	2012
New	Two story style home with attached 3 car garage				2012
New	One-story SFR with attached garage - 2009 IRC				2012
New	SFR - 2 story with attached garage (remove existing MH)				2012
New	Approved basic 10-108816 BP	2009 IRC	Plan# 1561	2-story duplex w/attache	2012

Accessory Dwelling Units

Index # - File Name: 1.0022 - Single Family Dwellings Data\_Snohomish County.pdf

New	2270 sf rambler with attached garage - 2009 IRC	2012
New	715 sf one-story detached accessory apartment - 2009 IRC	2012
New	SFR, two story home with unfinished basement, with 10 car garage and covered porch, 4 bedro	2012
New	Two story home with attached 3 car garage Engineered by Gary Thomas Nash, R.A. 2512	2012
New	Two-story SFR with 411 sf unfinished basement - 2009 IRC Engineered by Lori D. Brown, P.E. 37	2012
New	Approved basic 12-104782 BP 2009 IRC Plan# IN2012 2-story sfr w/attache	2012
New	Two Story SFR wih 422sq ft Finished Basement and Attached Garage	2012
New	New rambler style home with unfinished basement and attached garage	2012
New	Two-story SFR with attached garage - 2009 IRC	2012
New	Two-story SFR with attached garagae - 2009 IRC	2012
New	1 time extension granted. Application to expire September 8, 2012. HF Mid-entry SFR - 2006 IR	2012
New	Rebuild cabin using existing foundation, approximately 757 square feet	2012
New	Two story home with attached 3 car garage & covered porch (existing home & detached garage	2012
New	Construct new SFR. Old SFR from 1959 to be demolished.	2012
New	new SFR with FZ	2012
New	2035 sf rambler with attached garage - 2009 IRC	2012
New	849 sf SFR over 1173 sf garage with 100 sf covered porch - 2009 IRC	2012
New	SFR, rambler style with attached two garage, 3 bedrooms, 2 1/2 bath	2012
New	Approved basic 10-105761 2009 IRC Plan# Possession Lane Plan 2-story sfr w/attached ga	2012
New	41 x 68 2007 Palm Harbor Triple Wide to be used as a detached accessory apartment	2012
New	Two story home with attached garage and covered porch	2012
New	Single family home, 2 story with attached garage, covered porch, 7 bedrooms All mechanical ur	2012
New	Two-story Duplex with attached garage - 2009 IRC	2012
New	Rambler style sfr w/attached garage	2012
New	Approved basic 10-105501 BP 2009 IRC Plan# 2186 Rambler w/attached gara	2012
New	2 story sfr w/attached garage	2012
New	Manufactured home, 1981 Mansfield 28 x 44	2012
New	new SFR in footprint of old MH	2012
New	27 x 60 2012 double-wide Marlette Pacifica mobile home	2012
New	New permit to obtain final inspection for expired 03-107246-MH	2012
New	Extended expire to 6/30/14 for final inspection dm 6/26/14 Manufactured home, 2012, double	2012
New	Rambler style sfr w/attached garage	2012
New	Rambler-style SFR with attached garage - 2009 IRC	2012
New	Rebuild existing SFR	2012
New	2168 sf rambler with attached garage - 2009 IRC	2012
New	Approved basic 12-104629 BP 2009 IRC Plan# 1536 Rambler sfr w/attached garag	2012
New	67 x 14 1976 Marlette Mobile Home	2012
New	2170 sf rambler with attached garage -2009 IRC	2012
New	Rambler style home with 2 car garage (Mechanical & plumbing permits will be acquired separat	2012
New	Two-story sfr with finished daylight basement - 2009 IRC	2012
New	Two-story SFR with finished basement - 2009 IRC Engineered by Frank T. Jarnot, P.E. 25746	2012
New	Using 30 day grace period - original expire 9/10/13 --- 9/10/13 dm Two-story SFR - 2009 IRC	2012
New	Rambler with attached garage - 2009 IRC	2012
New	SFR, Rambler style with attached garage	2012
New	new SFR with Targeted Drainage Plan. See 12-108151-LDA. Existing MH to be removed or demo	2012
New	new SFR	2012
New	Two story SFR with unfinished first floor for workshop and storage	2012

Accessory Dwelling Units

Index # - File Name: 1.0022 - Single Family Dwellings Data\_Snohomish County.pdf

New	One-story SFR with attached garage - 2009 IRC	2012
New	Two-story SFR with attached garage - 2009 IRC	2012
New	SFR, two story style home with attached 2-car garage (3 bedrooms)	2012
New	1767 sf rambler with attached garage - 2009 IRC	2012
New	proposed covered area (22x20) over existing concrete slab. See 11-103195-PA	2012
New	Approved basic 10-109378 BP 2009 IRC Plan# 2726-49-8 2-story sfr w/attach	2012
New	Approved basic 12-104532 BP 2009 IRC Plan# 2582-40-8 2-story sfr w/attachec	2012
New	Approved basic 10-109378 BP 2009 IRC Plan# 2726-49-8 2-story sfr w/attach	2012
New	EXTENDED FOR 6 MONTHS to 10/24/12 per Mickiewick s 7/24/12 dm - orginal expire dated 5/	2012
New	Approved basic 10-106515 BP 2009 IRC Plan# 2664 2-story sfr w/attached garag	2012
New	New SFR with targeted drainage plan	2012
New	Approved basic 13-109681 BP 2012 IRC Plan# Harlequin 2-story sfr w/attachec	2013
New	Allowing until 6/26/13 to obtain final inspection 6/17/13 dm Rambler style sfr w/attached gara	2013
New	Rambler style sfr w/attached garage w/bonus room above	2013
New	1863 sf rambler style SFR with attached garage - 2009 IRC	2013
New	Residential building permit to construct a detached Accessory Apartment (AA)	2013
New	Approved basic 13-109681 BP 2012 IRC Plan# Harlequin 2-story sfr w/attachec	2013
New	Two-story SFR with attached garage - 2009 IRC	2013
New	SFR, rambler with attached two car garage and covered porch	2013
New	Two-story SFR with 553 sf finished basement and attached garage	2013
New	One-story SFR - 2009 IRC	2013
New	New house, Rambler with attached 2 car garage	2013
New	Two-story SFR with attached garage - 2009 IRC	2013
New	3343 sf rambler - 2009 IRC	2013
New	New rambler SFR with attached garage. See 13-106540-LDA	2013
New	1411SF Rambler with 404SF Attached Garage	2013
New	Remove existing MH and build new smaller SFR in existing footprint	2013
New	Manufactured Home 2013, triple wide, Pacifica (4 bedroom)	2013
New	New house, rambler with covered porch	2013
New	1800 sf SFR with 576 sf bonus room over attached garage - 2013 IRC	2013
New	Two-story SFR with attached garage - 2012 IRC	2013
New	Two-story SFR with finished basement - 2009 IRC	2013
New	Manufactured home for use as a Accessory Apartment, 1989 double wide Fuqua, 28 x 64	2013
New	Extended 30 days for final inspection on the LDA 6/2/15 dm New rambler style SFR w/ attache	2013
New	Two-story SFR with attached garage	2013
New	1526 sf rambler with attached garage - 2009 IRC	2013
New	2 story SFR w/ attached garage in area where old MH was removed.	2013
New	Approved basic 13-110770 BP 2012 IRC Plan: 2364 Two-story SFR with attached g	2013
New	Rambler style sfr w/attached garage	2013
New	2270 sf rambler with attached garage - 2009 IRC	2013
New	New SFR, Rambler (no garage) 3 bedroom/2bath, 1 kitchen, laundry room	2013
New	Residential building permit to construct a new detached accessory apartment	2013
New	1799 sf SFR with attached garage	2013
New	See review letter being tracked in 12-103698 LDA. Two-story SFR with attached garage - 2009	2013
New	Two-story SFR with attached garage - 2009 IRC	2013
New	New SFR, Rambler style with attached garage and covered porch, 2 bedroom	2013
New	Two Story SFR with Attached Garage	2013



Accessory Dwelling Units

Index # - File Name: 1.0022 - Single Family Dwellings Data\_Snohomish County.pdf

New	Two-story sfr with attached garage - 2009 IRC	2013
New	SFR, new house, rambler with attached 2-car garage, 2 bedroom, 2 bath	2013
New	SFR, 2 story with attached 2 car garage, 3 bedroom	2013
New	SFR, 2 story with attached 2 car garage, 3 bedroom	2013
New	1116 sf SFR with 1049 sf finished daylight basement and 540 sf attached garage - 2012 IRC	2013
New	Replacing fire destroyed SFR Rambler style sfr w/daylight basement w/attached garage	2013
New	Two-story sfr with attached garage - 2009 IRC	2013
New	Two-story SFR with attached garage and daylight basement original expire date June 26, 2015 -	2013
New	SFR, new rambler with daylight basement, attached two car garage and covered porch, 4 bedroom	2013
New	Rambler style sfr w/attached garage	2013
New	Rambler style sfr w/attached garage	2013
New	Two-story SFR	2013
New	2389 sf rambler with attached garage - 2009 IRC	2013
New	Duplex - 2009 IRC	2013
New	Approved Basic 10-108816-BP 2009 IRC 2 story duplex w/ attached gar	2013
New	2133 sf rambler with attached garage - 2012 IRC	2013
New	3838 sf SFR with 1074 sf attached garage - 2009 IRC	2013
New	Two Story SFR with Attached Garage	2013
New	2 story SFR with attached garage. See 13-104072-LDA.	2013
New	extension granted until December 27, 2013 with conditions see jennifer 08-10-2012 jrlind Thre	2013
New	Two Story SFR with Attached Garage	2013
New	Two Story SFR with Attached Garage	2013
New	New SFR with attached garage and Targeted Drainage Plan . See 13-109310-LDA.	2013
New	Manufactured Home, 2013, double wide, Golden West, 27 x 56	2013
New	Rambler style sfr w/attached garage (plans revised 04-30-2013)	2013
New	960 sf SFR for summer housing for Camp Pigott s Program Director - 2009 IRC	2013
New	Approved basic 10-105761 2009 IRC Plan# Possession Lane Plan 2-story sfr w/attached gar	2013
New	Two-story SFR with attached garage - 2009 IRC Engineer Frank Jarnot #25746	2013
New	850 sq ft detached accessory apartment w/attached garage	2013
New	2169 sf rambler with attached garage 2009 IRC	2013
New	Repair garage from car impact per engineered plans	2013
New	2 - story single family residence w/attached garage	2013
New	Demo old SFR & install new Mobile Home	2013
New	Repair roof trusses per engineered plans from tree strike damage to roof.	2013
New	2-story sfr w/attached garage w/bonus room over garage	2013
New	2 story SFRw/ attached garage - 2009 IRC	2013
New	Requesting to use 30 extenson dm (org expire date 7/23/14) 7/23/14 15 x 52 2012 Marlette	2013
New	2-story sfr w/attached garage	2013
New	Two Story SFR with Attached Garage	2013
New	Permit to resolve violation for converting building to an apartment without proper permits/app	2013
New	New mobile home as an Accessory Apartment: 1988 Goldenwest 28 x 66.	2013
New	Two-story SFR with attached garage - 2009 IRC	2013
New	Approved basic 10-107171 BP 2009 IRC Plan# Chellan II-A (3 Car) 2-story sfr w/atta	2013
New	Rebuild existing upper story deck and construct new patio cover over existing concrete patio im	2013
New	Reversed expired status for a one time inspection 1/29/15 dm This superseds Expired Status f	2013
New	Two-story duplex - 2009 IRC	2013
New	Two Story SFR with Attached Garage - 2009 IRC	2013

Accessory Dwelling Units

Index # - File Name: 1.0022 - Single Family Dwellings Data\_Snohomish County.pdf

New	New 2- story SFR & Garage with LDA and CAS. See 13-102401-LDA	2013
New	new 2 story SFR with attached garage. See 12-111017-LDA.	2013
New	2-story sfr w/attached garage	2013
New	Two-story SFR w/attached garage.	2013
New	New house, two story with attached garage, 3 bedroom	2013
New	Two-story SFR with attached garage - 2009 IRC	2013
New	New SFR 1379 sf first floor, 1394 sf second floor w/attached garage.	2013
New	New 2- stroy SFR with attached garage & targeted drainage plan. See 13-110790-LDA	2013
New	Two-story sfr with attached garage - 2012 IRC	2013
New	Two Story SFR with Attached Garage NSF Check - Accept only cash, bank draft, money order or	2013
New	Two-story duplex - 2009 IRC	2013
New	One story 1,248 sf SFR - 2009 IRC	2013
New	Converting existing single family residence to duplex	2013
New	Two-story SFR with attached garage - 2012 IRC	2013
New	Two-story SFR with attached garage - 2009 IRC	2013
New	Two-story SFR with attached garage - 2009 IRC Plan: 3420	2013
New	Two-story SFR with attached garage - 2009 IRC Plan: 3887	2013
New	2-story sfr w/attached garage	2013
New	new 1243 SF SFR with attached 528 SF garage. See 13-100193-LDA	2013
New	Detached family room / hobby room with bathroom 8/7/14 SEE FINAL LINE UNDER INSPECTIO	2013
New	Approved basic 13-112574 BP 2012 IRC Plan# Cascade II-A 2-story sfr w/attache	2013
New	Single family residence, two story with attached 2 car garage, 3 bedrooms	2013
New	27 x 53 2013 Skyline	2013
New	2-story sfr w/attached garage	2013
New	Approved basic 10-109367 BP 2009 IRC Plan# 2453 Rambler style sfr w/attached g	2013
New	Two-story SFR with attached garage and unfinished daylight basement - 2012 IRC	2013
New	28 x 56 1991 Redman Mobile Home	2013
New	1934 sf rambler style SFR with attached garage	2013
New	new 2-story SFR with attached garage	2013
New	Approved Basic 13-112583 2012 IRC. Plan # 1640 Rambler w/ attached 3 car garage (3 be	2013
New	3951 sf rambler-style SFR with attached garage - 2009 IRC	2013
New	2 story SFR with 3rd story loft	2013
New	Manufactured home 2013 double wide, Marlette Value Edition 14 x 60	2013
New	Manufactured home, 2012, double wide, 27 x 60, Marlette First Edition 9753	2013
New	New MH in MH park	2013
New	Manufactured home, 2013, double wide, Marlette First Edition 9753 dim 27 x 60	2013
New	27 x 70 2013 Marlette Mobile Home	2013
New	Log Cabin SFR with attached garage and full drainage plan. See 13-103011-LDA	2013
New	One story SFR with attached garage - 2012 IRC	2013
New	2-story sfr w/attached garage	2013
New	EXTENDED FOR 30 DAYS FROM 7/15/16 PER ALAN HUSBY ss 2 story SFR w/ attached garage	2013
New	2-story sfr w/finished daylight basement w/attached garage	2013
New	New 2 story SFR with attached garage	2013
New	SFR two story style home with attached garage, 4 bedroom	2013
New	1220 sf sfr with 384 sf upper floor unheated storage area and attached 1800 sf garage	2013
New	Two-story SFR with attached garage - 2009 IRC	2013
New	2-story sfr w/attached garage	2013

Accessory Dwelling Units

Index # - File Name: 1.0022 - Single Family Dwellings Data\_Snohomish County.pdf

New	2-story sfr w/attached garage				2013
New	Two-story SFR with attached garage - 2009 IRC				2013
New	Two-story SFR with attached garage - 2009 IRC				2013
New	Inspection only on master staircase in existing structure permitted under 10-103810-RK .				2013
New	Two-story SFR with attached garage - 2009 IRC				2013
New	new SFR Renewed RK & Driveway Permits 8/5/14 dm Engineered by Alex K. Moroseos, P.E. 369				2013
New	Approved basic 11-105360 BP 2009 IRC Plan# Cascade-B 3 car 2-story sfr w/attached ga				2013
New	Two-story SFR with attached garage				2013
New	Two-story SFR with attached garage - 2003 IRC				2013
New	New 2-story SFR with attached garage.				2013
New	Two new mobile structures for the purpose of bonus residential space and shop (not for habitat				2013
New	New SFR, rambler with attached 2 car garage, 3 bedroom / 2.5 bath				2013
New	2 story sfr w/ attached 3-car garage.				2013
New	2 story 4,751sf sfr w/ attached 1250sf garage.				2013
New	27 x 48 2013 Fleetwood Mobile Home				2013
New	640 sf SFR with 551 storage loft and 1360 sf attached garage				2013
New	Rambler style sfr w/attached garage				2013
New	Approved basic 11-101437 BP 2009 IRC Plan# 2671 2-story sfr w/attached garag				2013
New	Rambler style sfr w/attached garage w/bonus room above				2013
New	2-story sfr w/attached garage				2013
New	2-story sfr w/attached garage				2013
New	2-story sfr w/attached garage				2013
New	Two Story SFR with Attached Garage				2013
New	Rambler style sfr w/attached garage				2013
New	SFR, Two story with 3 car garage and covered porches, 4 bedroom				2013
New	Approved basic 13-112612 BP 2012 IRC Plan# 3315 2-story SFR w/attached				2013
New	Approved basic 13-112612 BP 2012 IRC Plan# 3315 2-story sfr w/attached g;				2013
New	Approved basic 13-112612 BP 2012 IRC Plan# 3315 2-story sfr w/attached g;				2013
New	Two Story SFR with Attached Garage				2013
New	SFR, Two story home with attached 3 car garage, 4 bedroom				2013
New	New 2- story SFR with attached garage				2013
New	SFR, two - story with atached 3 car garage and covered front porch				2013
New	New 2-story SFR with attached garage				2013
New	SFR, rambler style with attached 3 car garage, 3 bedroom 2.5 bath				2013
New	Rambler style sfr w/attached garage w/unfinished storage above				2013
New	1572 sf one-story SFR with attached garage - 2009 IRC				2013
New	One-story SFR with attached garage - 2009 IRC				2013
New	Install 1992 Fleetwood mobile home				2013
New	1543 sf Rambler with 824 sf daylight basement - 2009 IRC				2013
New	SFR, two story (no garage) 3 bedroom / 2 bath				2013
New	SFR, Two story with attached 3 car garage, 4 bedroom, 2 1/2 bath				2013
New	SFR, Two story with attached 3 car garage, 3 bedroom, 2 1/2 bath				2013
New	Two-story SFR with attached garage				2013
New	Approved basic 12-106030 BP 2009 IRC Plan# 1894 2-story sfr w/attached garağ				2013
New	Approved basic 12-106031 BP 2009 IRC Plan# 1975 2-story sfr w/attached gar				2013
New	Approved basic 12-106030 BP 2009 IRC Plan# 1894 2-story sfr w/attached garağ				2013
New	Approved basic 12-104629 BP 2009 IRC Plan# 1536 Rambler sfr w/attached garag				2013

Accessory Dwelling Units

Index # - File Name: 1.0022 - Single Family Dwellings Data\_Snohomish County.pdf

New	Approved basic 12-106031 BP	2009 IRC	Plan# 1975	2-story sfr w/attached gar	2013
New	Two Story SFR with 1232SF Unfinished Basement and 777SF Covered Porch				2013
New	SFR, two story with attached garage*****house fire - applicant will need to recall some ir				2013
New	New SFR, rambler with covered porches, front and back and attached 2 car garage with storage				2013
New	Approved basic 12-110563 BP	2009 IRC	Plan# Julia Grande	2-story sfr w/attac	2013
New	SFR, two story with attached 3 car garage and covered porch, 4 bedroom/4 bathroom				2013
New	Permit transfered to J & S Development LLC. 05-07-2013 jrind Approved Basic 12-109419 BF				2013
New	Approved basic 13-107399.	2012 IRC.	Plan 3624-RV.	2 story sfr w/ attached garage	2013
New	Approved basic 13-107401.	2012 IRC.	Plan 3494 4 car.	2 story sfr w/ attached 4 car	2013
New	Two-story SFR with attached garage - 2009 IRC				2013
New	New Two Story SFR with and attached garages				2013
New	2-story sfr w/attached garage				2013
New	2 story SFR with attached garage				2013
New	4200 sf rambler with attached garage				2013
New	Rambler style sfr w/attached garage				2013
New	Rambler style sfr w/attached garage				2013
New	Rambler style sfr w/attached garage NSF Check - Accept only cash, bank draft, money order or c				2013
New	Rambler style sfr w/attached garage				2013
New	Approved basic 11-103872 BP	2009 IRC	Plan# 1507	2-story sfr w/attached gar	2013
New	Approved basic 11-103872 BP	2009 IRC	Plan# 1507	2-story sfr w/attached gar	2013
New	Approved basic 12-104202 BP	2009 IRC	Plan# 2052	2-story sfr w/attached garage	2013
New	Approved basic 12-104202 BP	2009 IRC	Plan# 2052	2-story sfr w/attached garage	2013
New	Approved basic 12-104202 BP	2009 IRC	Plan# 2052	2-story sfr w/attached garage	2013
New	Approved basic 12-104202 BP	2009 IRC	Plan# 2052	2-story sfr w/attached garage	2013
New	Approved basic 12-104202 BP	2009 IRC	Plan# 2052	2-story sfr w/attached garage	2013
New	2 story sfr w/ attached garage.				2013
New	Approved basic 13-104362.	2009 IRC.	Plan # 1835.	2 story sfr w/ attache	2013
New	Approved Basic 13-104362. 2009 IRC. Plan # 1835. 2 story sfr w/ attached garage.				2013
New	Approved Basic 13-104361.	2009 IRC.	Plan # 1856.	2 story sfr w/ attached ga	2013
New	New SFR with attached garage				2013
New	Approved Basic 13-104361.	2009 IRC.	Plan # 1856.	2 story sfr w/ attached gar	2013
New	Approved basic 12-104575 BP	2009 IRC	Plan# 3102	2-story sfr w/attached gara	2013
New	Approved basic 12-104573 BP	2009 IRC	Plan# 2814	2-story sfr w/attached gara	2013
New	Approved basic 12-103898BP	2009 IRC	Plan# 2588	2-story sfr w/attached garag	2013
New	Approved basic 12-104573 BP	2009 IRC	Plan# 2814	2-story sfr w/attached gara	2013
New	Approved basic 12-109419 BP	2009 IRC	Plan #3494	2 story SFR with garage	2013
New	Two Story SFR with Attached Garage				2013
New	Approved basic 12-103896 BP	2009 IRC	Plan# 2607	2-story sfr w/attached	2013
New	Approved Basic 13-100958.	2009 IRC	Plan# 2244.	2 story sfr w/ attached garage.	2013
New	Approved Basic 13-100959.	2009 IRC	Plan # 2162.	2 Story sfr w/ attached garage.	2013
New	Approved Basic 13-100961.	2009 IRC	Plan # 2202.	2 story sfr w/ attached garage.	2013
New	Approved Basic 13-100956.	2009 IRC	Plan # 2000.	2 Story SFR w/ attached garage.	2013
New	Approved Basic 13-100955.	2009 IRC	Plan # 1984.	2 story SFR w/ attached garage.	2013
New	Approved Basic 13-100959.	2009 IRC	Plan # 2162.	2 Story sfr w/ attached garage.	2013
New	Approved Basic 13-100961.	2009 IRC	Plan # 2202.	2 story sfr w/ attached garage.	2013
New	Approved Basic 13-100956.	2009 IRC	Plan # 2000.	2 Story SFR w/ attached garage.	2013
New	Approved Basic 13-100955.	2009 IRC	Plan # 1984.	2 story SFR w/ attached garage.	2013

Accessory Dwelling Units

Index # - File Name: 1.0022 - Single Family Dwellings Data\_Snohomish County.pdf

New	Approved	Basic 13-100959.	2009 IRC .	Plan # 2162.	2 Story sfr w/ attached garage.	2013
New	Approved	Basic 13-100958.	2009 IRC	Plan# 2244.	2 story sfr w/ attached garage.	2013
New	Approved	Basic 13-100956.	2009 IRC .	Plan # 2000.	2 Story SFR w/ attached garage.	2013
New	Approved	Basic 13-100961.	2009 IRC .	Plan # 2202.	2 story sfr w/ attached garage.	2013
New	Approved	Basic 13-100959.	2009 IRC .	Plan # 2162.	2 Story sfr w/ attached garage.	2013
New	Approved	Basic 13-100958.	2009 IRC .	Plan# 2244.	2 story sfr w/ attached garage.	2013
New	Approved	Basic 13-100958.	2009 IRC .	Plan# 2244.	2 story sfr w/ attached garage.	2013
New	Approved	Basic 13-100958.	2009 IRC	Plan# 2244.	2 story sfr w/ attached garage.	2013
New	Approved	Basic 13-100958.	2009 IRC .	Plan# 2244.	2 story sfr w/ attached garage.	2013
New	Approved	Basic 13-100961.	2009 IRC .	Plan # 2202.	2 story sfr w/ attached garage.	2013
New	Approved	Basic 13-100959.	2009 IRC .	Plan # 2162.	2 Story sfr w/ attached garage.	2013
New	Approved	Basic 13-100956.	2009 IRC .	Plan # 2000.	2 Story SFR w/ attached garage.	2013
New	Approved	Basic 13-100962.	2009 IRC	. Plan #2074.	2 story sfr w/ attached garage.	2013
New	Approved	Basic 13-100961.	2009 IRC .	Plan # 2202.	2 story sfr w/ attached garage.	2013
New	Approved	Basic 13-100959.	2009 IRC .	Plan # 2162.	2 Story sfr w/ attached garage.	2013
New	Approved	Basic 13-100956.	2009 IRC .	Plan # 2000.	2 Story SFR w/ attached garage.	2013
New	Approved	Basic 13-100962.	2009 IRC	. Plan #2074.	2 story sfr w/ attached garage.	2013
New					2 story sfr w/ attached garage.	2013
New					Rambler style sfr w/daylight basement w/attached garage	2013
New					2 story sfr w/ attached garage	2013
New					2 story sfr w/ attached garage.	2013
New					2 story sfr w/ attached garage.	2013
New					2 story sfr w/ attached garage.	2013
New					2 story sfr w/ attached garage.	2013
New					2 story sfr w/ attached garage and daylight basement.	2013
New					2-story sfr w/daylight basement w/attached garage	2013
New					Rambler style sfr w/daylight basement w/attached garage	2013
New					2 story sfr w/ attached garage.	2013
New					2 story sfr w/ attached garage.	2013
New					2 story sfr w/daylight basement w/attached garage	2013
New					2-story sfr w/daylight basement w/attached garage	2013
New					2 story sfr w/ daylight basement and attached garage. Revision - convert tandem portion of gar	2013
New					Rambler style sfr w/daylight basement w/attached garage	2013
New					2-story sfr w/daylight basement w/attached garage	2013
New					2-story sfr w/daylight basement w/attached garage	2013
New					2 story sfr w/ attached garage and daylight basement	2013
New					2 story sfr w/ attached garage and daylight basement	2013
New					2 story sfr w/ attached garage and daylight basement	2013
New					2 story sfr w/ attached garage.	2013
New					Rambler w/daylight basement w/attached garage	2013
New					2 story sfr w/ daylight basement and attached garage.	2013
New					2 story sfr w/ attached garage and daylight basement	2013
New					2 story sfr w/ attached garage and daylight basement	2013
New					2 story sfr w/ daylight basement and attached garage. Revision - convert tandem portion of gar	2013
New					2 story sfr w/ attached garage and daylight basement	2013
New					New SFR - Rambler w/ attached 2-car garage, loft and covered front porch	2013

Accessory Dwelling Units

Index # - File Name: 1.0022 - Single Family Dwellings Data\_Snohomish County.pdf

New	Rambler style sfr w/attached garage and bonus above garage					2013
New	Rambler style sfr w/daylight basement w/attached garage					2013
New	Rambler style sfr w/daylight basement w/attached garage					2013
New	2 story sfr w/ attached garage.					2013
New	Rambler style sfr w/daylight basement w/attached garage					2013
New	Rambler style sfr w/daylight basement w/attached garage					2013
New	Rambler style sfr w/daylight basement w/attached garage					2013
New	1 story SFR w/ daylight basement and attached garage.					2013
New	Rambler style sfr w/attached garage					2013
New	Approved basic 10-109367 BP	2009 IRC	Plan# 2453	Rambler style sfr w/attached garage		2013
New	Approved basic 10-109367 BP	2009 IRC	Plan# 2453	Rambler style sfr w/attached garage		2013
New	Rambler style sfr w/attached garage					2013
New	Rambler style sfr w/attached garage					2013
New	Rambler style sfr w/attached garage					2013
New	Rambler style sfr w/attached garage					2013
New	Rambler style sfr w/attached garage					2013
New	Rambler style sfr w/attached garage					2013
New	Rambler style sfr w/attached garage					2013
New	Rambler style sfr w/attached garage					2013
New	Extended for 30 days to allow for final inspection 5/15/15 dm			New 2-story SFR w/ finished basement		2013
New	Two Story SFR with Attached Garage					2013
New	Two Story SFR with Attached Garage and 938SF Finished Basement					2013
New	Approved basic 13-101740 BP	2009 IRC	Plan# 2710-30-9	2-story sfr w/attached garage		2013
New	Approved basic 13-105550 BP	2009 IRC	Plan# 3010-30-9	2-story sfr w/TUCK under garage		2013
New	Approved basic 13-105551 BP	2009 IRC	Plan# 3111-30-9	2-story sfr w/TUCK UNDER garage		2013
New	Approved basic 13-101740 BP	2009 IRC	Plan# 2710-30-9	2-story sfr w/attached garage		2013
New	Approved basic 13-101740 BP	2009 IRC	Plan# 2710-30-9	2-story sfr w/attached garage		2013
New	Approved basic 12-108643 BP	2009 IRC	Plan# 2777	2-story sfr w/attached garage		2013
New	Approved basic 12-100357 BP	2009 IRC	Plan# 2279-30-8	2-story sfr w/attached garage		2013
New	Approved basic 12-104532 BP	2009 IRC	Plan# 2582-40-8	2-story sfr w/attached garage		2013
New	Approved basic 13-101740 BP	2009 IRC	Plan# 2710-30-9	2-story sfr w/attached garage		2013
New	Approved basic 12-108643 BP	2009 IRC	Plan# 2777	2-story sfr w/attached garage		2013
New	Approved basic 12-108641 BP	2009 IRC	Plan# 2557	2-story sfr w/attached garage		2013
New	Approved basic 12-110444 BP	2009 IRC	Plan# 2198/2	2-story sfr w/attached garage		2013
New	Approved basic 12-110444 BP	2009 IRC	Plan# 2198/2	2-story sfr w/attached garage		2013
New	Approved basic 12-110050 BP	2009 IRC	Plan# 2417/2	2-story sfr w/attached garage		2013
New	Approved basic 13-103284 BP	2009 IRC	Plan#2975/2	2-story sfr w/attached garage		2013
New	Approved basic 12-110055 BP	2009 IRC	Plan# 2683/2	2-story sfr w/attached garage		2013
New	Approved basic 12-110042 BP	2009 IRC	Plan# 2885/2	2-story sfr w/attached garage		2013
New	Approved basic 12-110444 BP	2009 IRC	Plan# 2198/2	2-story sfr w/attached garage		2013
New	Approved basic 13-103284 BP	2009 IRC	Plan#2975/2	2-story sfr w/attached garage		2013
New	Approved basic 12-110055 BP	2009 IRC	Plan# 2683/2	2-story sfr w/attached garage		2013
New	Approved basic 12-110042 BP	2009 IRC	Plan# 2885/2	2-story sfr w/attached garage		2013
New	Approved basic 13-103284 BP	2009 IRC	Plan#2975/2	2-story sfr w/attached garage		2013
New	Approved basic 12-110052 BP	2009 IRC	Plan# 2536/2	2-story sfr w/attached garage		2013
New	Approved basic 13-103284 BP	2009 IRC	Plan#2975/2	2-story sfr w/attached garage		2013
New	2-story sfr w/attached garage					2013
New	Approved basic 12-110444 BP	2009 IRC	Plan# 2198/2	2-story sfr w/attached garage		2013

Accessory Dwelling Units

Index # - File Name: 1.0022 - Single Family Dwellings Data\_Snohomish County.pdf

New	Approved basic 12-110050 BP	2009 IRC	Plan# 2417/2	2-story sfr w/atta	2013
New	Approved basic 12-110052 BP	2009 IRC	Plan# 2536/2	2-story sfr w/attach	2013
New	Approved basic 12-108642 BP	2009 IRC	Plan# 2102	2-story sfr w/attached garage	2013
New	Approved basic 13-101742 BP	2009 IRC	Plan# 3054-40-9	2-story sfr w/attache	2013
New	new Rambler SFR with attached garage. See 13-108556-LDA				2013
New	Approved basic 11-104779 BP	2009 IRC	Plan# 1468	Rambler style sfr w/attached ga	2013
New	Approved basic 12-103588 BP	2009 IRC	Plan# 1640	2-story sfr w/attached garage	2013
New	Approved basic 12-103589 BP	2009 IRC	Plan# 1510	Rambler style sfr w/attached	2013
New	Approved basic 12-103416 BP	2009 IRC	Plan# 1850 - 2-story	2-story sfr w/attach	2013
New	Approved basic 12-110207 BP	2009 IRC	Plan#3540-3	2-story sfr w/attached garage	2013
New	Approved basic 11-105561 BP	2009 IRC	Plan# 3431-3	2-story sfr w/attached	2013
New	2-story sfr w/attached garage				2013
New	Two-story SFR with finished basement and attachd garage - 2009 IRC				2013
New	2-story duplex w/attached garages				2013
New	Approved basic 13-105888 BP	2009 IRC	Plan# 3501	2-story sfr w/attached garage	2013
New	Approved basic 11-107680 BP	2009 IRC	Plan# 4173-3	2-story w/daylight basement w	2013
New	2-story sfr w/attached garage w/daylight basement				2013
New	Approved basic 11-107680 BP	2009 IRC	Plan# 4173-3	2-story w/daylight basement w	2013
New	2-story sfr w/attached garage w/daylight basement				2013
New	Approved basic 13-110055 BP.	2012 IRC.	Plan #18-30.02 D - Henley4.	2 story sfr w/ attach	2013
New	Approved basic 13-109805 BP.	2012 IRC.	Plan # 33-30.02 H - Henley4.	2 story sfr w/ att	2013
New	2 story sfr w/ attached garage.				2013
New	2 story sfr w/ attached garage.				2013
New	Approved basic 13-111956 BP	2012 IRC	Plan# 34-30.02 P2 - Henley6	2-story	2013
New	2 story sfr w/ attached garage.				2013
New	Approved basic 13-110388 BP.	2012 IRC.	Plan #20-30.02 E (.2) - Henley5.	2 story sfr w/ att	2013
New	Approved basic 13-109801 BP.	2012 IRC.	Plan # 20.30.02 F (.2) - Henley4.	2 story sfr w/ at	2013
New	Approved basic 13-104352.	IRC 2009.	Plan # 2-30.025 A - Henley.	2 story sfr w/ attached ga	2013
New	Approved basic 13-111836.	2012 IRC.	Plan #31-30.32 V Henley6.	2 story sfr w/ attached	2013
New	2 story sfr w/ attached garage.				2013
New	2 story sfr w/ attached garage.				2013
New	2 story sfr w/ attached garage.				2013
New	Approved Basic 13-104846 BP.	2009 IRC.	Plan # 19-30.02	2 story sfr w/ attached	2013
New	Approved Basic 13-104364.	2009 IRC.	Plan #3-30.02 A - Henley.	2 story sfr w/ attached garag	2013
New	2 story sfr w/ attached garage.				2013
New	Approved basic 13-109799 BP.	2012 IRC.	Plan # 35-30.02 F2 - Henley4.	2 story sfr w/ at	2013
New	Approved basic 13-110883.	2012 IRC.	Plan # 32-30.02 V - Henley5.	2 story sfr w/ attached	2013
New	Approved Basic 13-101337.	2009 IRC	Plan #: 3308-3.	2 story sfr w/ attached gara	2013
New	2-story sfr w/attached garage				2013
New	Approved basic 12-104193 BP	2009 IRC	Plan# Palmer B	3 story sfr w/attached gar	2013
New	2-story sfr w/attached garage.				2013
New	Approved Basic 13-100884 BP	2009 IRC	Plan # 20-30.02M (.2) HENLEY.	2 story sfr w/ atta	2013
New	Approved Basic 13-108546 BP.	2012 IRC.	Plan # 33-30.02 V4.	2 story sfr w/ attache	2013
New	2 story sfr w/ attached garage.				2013
New	Approved basic 13-108542 BP.	2012 IRC.	Plan #35-30.02 T4.	2 story sfr w/ attached ga	2013
New	Approved basic 13-108614 BP	2012 IRC	Plan# 35-30.02 F2 - HENLEY2	2-story sfr w/atta	2013
New	Approved basic 13-111600.	2012 IRC.	Plan # 35-30.02H L.	2 story sfr w/ attache	2013

Accessory Dwelling Units

Index # - File Name: 1.0022 - Single Family Dwellings Data\_Snohomish County.pdf

New	2-story sfr w/attached garage				2013
New	Two-story SFR with finished basement - 2009 IRC				2013
New	Approved basic 12-104680 BP	2009 IRC	Plan# Mason-B	2-story sfr w/attached	2013
New	Approved basic 10-107475 BP	2009 IRC	Plan# Franklin B	2-story sfr w/attached	2013
New	Approved basic 10-105537 BP	2009 IRC	Plan # Blakely B	2-story sfr w/attached ga	2013
New	Approved basic 12-103430 BP	2009 IRC	Plan# 2823	2-story sfr w/attached garage	2013
New	Approved basic 12- 103427 BP	2009 IRC	Plan# 2595	2-story sfr w/attached ga	2013
New	Approved basic 12-106479 BP	2009 IRC	Plan# 2923	Rambler style sfr w/attached g	2013
New	2 story sfr w/ attached garage.				2013
New	Approved basic 12-103425 BP	2009 IRC	Plan# 2208	2-story sfr w/attached gar	2013
New	Approved basic 12-103430 BP	2009 IRC	Plan# 2823	2-story sfr w/attached garage	2013
New	Approved basic 12-103430 BP	2009 IRC	Plan# 2823	2-story sfr w/attached garage	2013
New	Approved basic 12- 103427 BP	2009 IRC	Plan# 2595	2-story sfr w/attached ga	2013
New	Approved basic 12- 103427 BP	2009 IRC	Plan# 2595	2-story sfr w/attached ga	2013
New	Approved basic 12- 103427 BP	2009 IRC	Plan# 2595	2-story sfr w/attached ga	2013
New	Rambler w/ attached garage.				2013
New	Approved basic 12-103430 BP	2009 IRC	Plan# 2823	2-story sfr w/attached garage	2013
New	Approved basic 12-103425 BP	2009 IRC	Plan# 2208	2-story sfr w/attached gar	2013
New	Approved basic 12-106360 BP	2009 IRC	Plan# 2904	Rambler style sfr w/attached	2013
New	Approved basic 12-106360 BP	2009 IRC	Plan# 2904	Rambler style sfr w/attached	2013
New	Approved basic 11-101566 BP	2009 IRC	Plan# Juno A	Rambler w/attached garage	2013
New	Approved basic 12-104440 BP	2009 IRC	Plan# 2146	2-story sfr w/attached garage	2013
New	Approved basic 13-106045 BP	2009 IRC	Plan# 1704 daylight	Rambler w/attached	2013
New	Approved basic 13-106045 BP	2009 IRC	Plan# 1704 daylight	Rambler w/attached	2013
New	Approved basic 10-106689 BP	2009 IRC	Plan# Jupiter	Rambler w/attached garage	2013
New	Approved basic 12-109465 BP	2009 IRC	Plan# June 1866	Rambler style sfr w/i	2013
New	Approved basic 12-109466 BP	2009 IRC	Plan # Jupiter 2005	2-story sfr w/attach	2013
New	Approved basic 12-109465 BP	2009 IRC	Plan# June 1866	Rambler style sfr w/i	2013
New	Approved basic 12-104440 BP	2009 IRC	Plan# 2146	2-story sfr w/attached garage	2013
New	Approved basic 13-101858 BP	2009 IRC	Plan# 2200	2-story sfr w/attached g	2013
New	Approved basic 10-106693 BP	2009 IRC	Plan# Julia	2-story sfr w/attached garage	2013
New	Rambler style sfr w/unfinished daylight basement w/attached garage				2013
New	Approved basic 12- 103427 BP	2009 IRC	Plan# 2595	2-story sfr w/attached ga	2013
New	Approved basic 12-103425 BP	2009 IRC	Plan# 2208	2-story sfr w/attached gar	2013
New	Approved basic 12- 103427 BP	2009 IRC	Plan# 2595	2-story sfr w/attached ga	2013
New	2 story sfr w/ attached garage.				2013
New	Approved basic 12- 103427 BP	2009 IRC	Plan# 2595	2-story sfr w/attached ga	2013
New	Two Story SFR with Attavched Garage				2013
New	2325 sf SFR with 526 sf bonus room over a 778 sf attached garage - 2009 IRC				2013
New	new 2- story SFR with attached garage				2013
New	new SFR with finished basement and attached garage				2013
New	Approved basic 12-103430 BP	2009 IRC	Plan# 2823	2-story sfr w/attached garage	2013
New	SFR, rambler style with attached 2 car garage				2013
New	Approved basic 13-113678 BP	2012 IRC	Plan# 27-40.02 W4- Henley11	2-story sfr w	2013
New	Approved basic 13-112519 BP	2012 IRC	Plan# 28-40.02 S5 - Henley8	2-story sfr w	2013
New	Approved basic 13-110734 BP	2012 IRC	Plan# 20-30.12 M - Creekstone	2-story sf	2013
New	Approved basic 13-105773 BP	2009 IRC	Plan# 35-30.02 T4 - Henley	2-story sfr w/att	2013



Accessory Dwelling Units

Index # - File Name: 1.0022 - Single Family Dwellings Data\_Snohomish County.pdf

New	Approved	basic 13-106930 BP	2009 IRC	Plan# 33-30.12 V4 - HENLEY	2-story sfr w/	2013
New	Approved	basic 13-105789 BP	2009 IRC	Plan# 22-40.02 S5 - Henley	2-story sfr w/attac	2013
New	Approved	basic 13-106896 BP	2009 IRC	Plan# 33-30.12 F - HENELY	2-story sfr w/att	2013
New	Approved	basic 13-105779 BP	2009 IRC	Plan# 22-40.02 A4 - Henley	2-story sfr w/a	2013
New	Approved	basic 13-107889 BP	2012 IRC	Plan# 24-40.02 F4 - HENLEY	2-story sfr w/attac	2013
New	Approved	basic 13-107717 BP	2012 IRC	Plan# 22-40.02 A4 - HENLEY	2-story sfr w/attac	2013
New	Approved	basic 13-107720 BP	2012 IRC	Plan# 31-30.32 U4 - HENLEY	2-story sfr w/attac	2013
New	Approved	basic 13-108196 BP	2012 IRC	Plan# 25-40.02 S6 - HENLEY2	2-story sfr w/at	2013
New	Approved	basic 13-108541 BP.	2012 IRC.	Plan #24-40.02 XA	2 story sfrw/ attached garage	2013
New	Approved	basic 13-108542 BP.	2012 IRC.	Plan #35-30.02 T4.	2 story sfr w/ attached ga	2013
New	Approved	basic 13-111322.	IRC 2012.	Plan # 35-30.02 F - Henley6.	2 story sfr w/ attached	2013
New	Approved	basic 13-107612 BP	2012 IRC	Plan# 2457/2DB	2-story sfr w/attached garag	2013
New	Approved	basic 13-111600.	2012 IRC.	Plan # 35-30.02H L.	2 story sfr w/ attache	2013
New	Approved	basic 13-105773 BP	2009 IRC	Plan# 35-30.02 T4 - Henley	2-story sfr w/att	2013
New	Approved	basic 13-105777 BP	2009 IRC	Plan# 32-30.02 V4 - Henley	2-story sfr w/attac	2013
New	Approved	basic 13-106802 BP	2009 IRC	Plan# 35-30.02 F2 - HENLEY	2-story sfr w/	2013
New	Approved	basic 13-107144 BP	2009 IRC	Plan# 33-30.02 H - HENLEY	2-story sfr w/attache	2013
New	Approved	basic 13-105773 BP	2009 IRC	Plan# 35-30.02 T4 - Henley	2-story sfr w/att	2013
New	Approved	basic 13-108168 BP	2012 IRC	Plan# 25-40.02 S5 - HENLEY	2-story sfr w/atta	2013
New	Approved	basic 13-109260 BP	2012 IRC	Plan# 24-40.02 XA4 - HENLEY3	2-story sfr w	2013
New	Approved	basic 13-109261 BP	2012 IRC	Plan# 22-40.02 A - HENLEY3	2-story sfr w/	2013
New	Approved	basic 13-112660.	2012 IRC.	Plan #24-40.02 F.	2 story sfr w/ attache	2013
New		2 story sfr w/ attached garage				2013
New	Approved	Basic 13-101011.	IRC 2009.	Plan # 2577.	2 story sfr w/ attached garage.	2013
New	Approved	Basic 13-101010.	IRC 2009.	Plan # 2441.	2 story sfr w/ attached garage.	2013
New		2 story sfr w/ attached garage.				2013
New	Approved	Basic 13-101009.	IRC 2009.	Plan # 2364.	2 story sfr w/ attached garage.	2013
New	Approved	Basic 13-102345-BP	2009 IRC.	Plan # 2992.	2 story sfr w/ attache	2013
New	Approved	basic 13-102345 BP	2009 IRC.	Plan # 2992.	2 story sfr w/ attached g	2013
New	Approved	basic 13-102472 BP	2009 IRC	Plan# 2660	2-story sfr w/attached ga	2013
New	Approved	basic 13-102472 BP	2009 IRC	Plan# 2660	2-story sfr w/attached ga	2013
New	Approved	Basic 13-102345.	IRC 2009.	Plan # 2992.	2 story SFR w/ attached gar	2013
New	Approved	basic 13-100671 BP	2009 IRC	Plan# 2575	2-story sfr w/attached gara	2013
New	Approved	basic 13-100671 BP	2009 IRC	Plan# 2575	2-story sfr w/attached g	2013
New	Approved	basic 13-100671 BP	2009 IRC	Plan# 2575	2-story sfr w/attached g	2013
New		2 story SFR w/ attached garage.				2013
New	Approved	basic 13-100063 BP	2009 IRC	Plan# 2339	2-story sfr w/attached garage	2013
New	Approved	Basic 13-101011.	IRC 2009.	Plan # 2577.	2 story sfr w/ attached garage.	2013
New	Approved	Basic 13-101010.	IRC 2009.	Plan # 2441.	2 story sfr w/ attached garage.	2013
New	Approved	Basic 13-101013.	IRC 2009.	Plan # 2588.	2 story sfr w/ attached garage.	2013
New	Approved	basic 12-104511 BP	2009 IRC	Plan# 2381	2-story sfr w/attached g	2013
New		2 story sfr w/ attached garage.				2013
New	Approved	basic 13-100063 BP	2009 IRC	Plan# 2339	2-story sfr w/attached garage	2013
New	Approved	Basic 13-101011.	IRC 2009.	Plan # 2577.	2 story sfr w/ attached garage.	2013
New	Approved	Basic 13-101009.	IRC 2009.	Plan # 2364.	2 story sfr w/ attached garage.	2013
New	Approved	basic 13-100063 BP	2009 IRC	Plan# 2339	2-story sfr w/attached garage	2013
New		SFR, new two story home with attached garage and covered porch, 4 bedroom				2013

Accessory Dwelling Units

Index # - File Name: 1.0022 - Single Family Dwellings Data\_Snohomish County.pdf

New	Approved basic 10-106094 BP	2009 IRC	Plan# 3724-A	2-story sfr w/attached gara	2013
New	Approved basic 12-102534 BP	2009 IRC	Plan# 3733-B	2-story sfr w/attached gara	2013
New	Approved basic 12-108549 BP	2009 IRC	Plan# 3729-A	2-story sfr w/attached g	2013
New	Approved basic 10-106095 BP	2009 IRC	Plan # 3724-B	2-story sfr w/attached garag	2013
New	Approved basic 12-102533 BP	2009 IRC	Plan#3733-A	2-story sfr w/attached g	2013
New	Approved basic 12-108551 BP	2009 IRC	Plan# 3729-B	2-story sfr w/attached ga	2013
New	Approved basic 13-103550 BP	2009 IRC	Plan# 3750	2-story sfr w/attached g	2013
New	Approved Basic 13-103961 BP	2009 IRC	Plan# 2160	Two Story Home with attached :	2013
New	Rambler with attached 3 car garage, (4 bedroom, 2 bath)				2013
New	2-story sfr w/attached garage				2013
New	Rambler style sfr w/attached garage				2013
New	Rambler style sfr w/attached garage				2013
New	Approved basic 12-109465 BP	2009 IRC	Plan# June 1866	Rambler style sfr w/i	2013
New	new SFR with attached garage & LDA				2013
New	Rambler style sfr w/attached garage and bonus above				2013
New	Approved Basic 13-102430.	2009 IRC.	Plan # 3019A.	2 story sfr w/ attached gara	2013
New	Approved Basic 13-102426.	IRC 2009.	Plan # 3014C.	2 story sfr w/ attached gara	2013
New	Approved Basic 13-102431.	2009 IRC.	Plan # 3019C.	2 story sfr w/ attache	2013
New	Approved Basic 13-102429.	2009 IRC.	Plan # 3014B.	2 story SFR w/ attached g	2013
New	Approved Basic 13-102430.	2009 IRC.	Plan # 3019A.	2 story sfr w/ attached gara	2013
New	Approved Basic 13-102426.	IRC 2009.	Plan # 3014C.	2 story sfr w/ attached gara	2013
New	Approved Basic # 13-102414.	IRC 2009.	Plan # 3013A.	2 story SFR w/ attached garage.	2013
New	Approved Basic 13-102419.	IRC 2009.	Plan # 3013C.	2 story SFR w/ attached gara	2013
New	Approved Basic 13-102429.	2009 IRC.	Plan # 3014B.	2 story SFR w/ attached	2013
New	Approved Basic 13-102430.	2009 IRC.	Plan # 3019A.	2 story sfr w/ attached gara	2013
New	Approved Basic 13-102426.	IRC 2009.	Plan # 3014C.	2 story sfr w/ attached gara	2013
New	Approved Basic 13-102431.	2009 IRC.	Plan # 3019C.	2 story sfr w/ attache	2013
New	Approved Basic 13-102431.	2009 IRC.	Plan # 3019C.	2 story sfr w/ attache	2013
New	Approved Basic 13-102429.	2009 IRC.	Plan # 3014B.	2 story SFR w/ attached g	2013
New	Approved Basic 13-102419.	IRC 2009.	Plan # 3013C.	2 story SFR w/ attached gara	2013
New	Approved basic 13-103524 BP	2009 IRC	Plan# 4028A	2-story sfr w/attached ga	2013
New	Approved Basic 13-102430.	2009 IRC.	Plan # 3019A.	2 story sfr w/ attached gara	2013
New	Approved Basic 13-102426.	IRC 2009.	Plan # 3014C.	2 story sfr w/ attached gara	2013
New	Approved Basic 13-102431.	2009 IRC.	Plan # 3019C.	2 story sfr w/ attache	2013
New	Approved Basic 13-102429.	2009 IRC.	Plan # 3014B.	2 story SFR w/ attached g	2013
New	Approved Basic 13-102430.	2009 IRC.	Plan # 3019A.	2 story sfr w/ attached gara	2013
New	Approved Basic # 13-102414.	IRC 2009.	Plan # 3013A.	2 story SFR w/ attached garage.	2013
New	Approved Basic 13-102431.	2009 IRC.	Plan # 3019C.	2 story sfr w/ attache	2013
New	Approved basic 13-103524 BP	2009 IRC	Plan# 4028A	2-story sfr w/attached ga	2013
New	Approved basic 13-105070.	2009 IRC.	Plan #4023-A.	2 story sfr w/ attach	2013
New	Approved basic plan 13-103529 BP	2009 IRC	Plan#4035C	2-story sfr w/attached	2013
New	Approved basic 13-103524 BP	2009 IRC	Plan# 4028A	2-story sfr w/attached ga	2013
New	Approved basic 13-103528 BP	2009 IRC	Plan# 4035B	2-story sfr w/attached gar	2013
New	Approved Basic 13-105072 BP	2009 IRC.	Plan # 4023C.	2 story sfr w/ attached ga	2013
New	Approved basic 13-103527 BP	2009 IRC	Plan# 4035A	2-story sfr w/attached gar	2013
New	Approved Basic 13-105072 BP	2009 IRC.	Plan # 4023C.	2 story sfr w/ attached ga	2013
New	Approved basic 13-103528 BP	2009 IRC	Plan# 4035B	2-story sfr w/attached gar	2013

Accessory Dwelling Units

Index # - File Name: 1.0022 - Single Family Dwellings Data\_Snohomish County.pdf

New	Approved basic 13-103526 BP	2009 IRC	Plan# 4028C	2-story sfr w/attached garage	2013
New	Approved basic plan 13-103529 BP	2009 IRC	Plan#4035C	2-story sfr w/attached	2013
New	Approved basic 13-105778 BP	2009 IRC	Plan# 23-40.02 W3 - Henley	2-story sfr w/atta	2013
New	Approved basic 13-106797 BP	2009 IRC	Plan# 21-40.02 XA2 - HENLEY	2-story sfr w/at	2013
New	Approved basic 13-106812 BP	2009 IRC	Plan# 34-30.02 U4 - HENLEY	2-story sfr w	2013
New	Approved basic 13-106934 BP	2009 IRC	Plan# 25-40.02 S5 - HENLEY	2-story sfr w/a	2013
New	Approved basic 13-106849 BP	2009 IRC	Plan# 26-40.02 A4 - HENLEY	2-story sfr w/a	2013
New	Approved basic 13-105796 BP	2009 IRC	Plan# 34-30.02 P2 - Henley	2-story sfr w/at	2013
New	Approved basic 13-105789 BP	2009 IRC	Plan# 22-40.02 S5 - Henley	2-story sfr w/attach	2013
New	Approved basic 13-106934 BP	2009 IRC	Plan# 25-40.02 S5 - HENLEY	2-story sfr w/a	2013
New	Approved basic 13-109507.	2012 IRC.	Plan # 26-40.02 T3 - Henley 2.	2 story sfr w/ attached	2013
New	Approved basic 13-109509.	2012 IRC.	Plan # 22-40.02 F2 - HENLEY 2.	2 story sfr w/ attached	2013
New	Approved basic 13-106899 BP	2009 IRC	Plan# 26-40.02 H4 - HENLEY	2-story sfr w/atta	2013
New	Approved basic 13-106799 BP	2009 IRC	Plan# 25-40.02 W3 - HENLEY	2-story sfr w/at	2013
New	Approved basic 13-106797 BP	2009 IRC	Plan# 21-40.02 XA2 - HENLEY	2-story sfr w/a	2013
New	Approved basic 13-106899 BP	2009 IRC	Plan# 26-40.02 H4 - HENLEY	2-story sfr w/atta	2013
New	Approved basic 13-105778 BP	2009 IRC	Plan# 23-40.02 W3 - Henley	2-story sfr w/atta	2013
New	Approved basic 13-113194 BP.	2012 IRC.	Plan # 31-30.12 U4.	2 story sfr w/ attached gara	2013
New	2-story sfr w/attached garage	*****	Amended Soils required per Targeted Drainage		2013
New	Approved Basic 13-102345.	IRC 2009.	Plan # 2992.	2 story SFR w/ attached ga	2013
New	Two-story SFR with attached garage				2013
New	24 x 46 Liberty 1984 double-wide MH.				2013
New	Approved basic 13-107401.	2012 IRC.	Plan 3494 4 car.	2 story sfr w/ attached 4 car	2013
New	Approved basic 13-110887.	2012 IRC.	Plan # 4048.3.0B	2 story sfr w/ attached garage	2013
New	Approved basic 13-110329 BP	2012 IRC	Plan# 4153.3.0C	2-story sfr w/attached g	2013
New	Approved basic 13-106973 BP	2012 IRC	Plan# 448 A	2-story sfr w/attached garage	2013
New	Approved basic 13-111035 BP	2012 IRC	Plan# 455 AB	2-story sfr w/attached gara	2013
New	Approved Basic 13-108398 BP.	2012 IRC.	Plan #448 B.	2 story sfr w/ attached gara	2013
New	Approved basic 13-106974 BP	2012 IRC	Plan# 471 AB	2-story sfr w/attached garage	2013
New	Approved basic 13-107401BP.	2012 IRC.	Plan 3494 4 car.	2 story sfr w/ attached 4	2013
New	Approved basic 13-107544 BP	2012 IRC	Plan# 2240	2-story sfr w/attached garage	2013
New	Approved 13-107545 BP	2012 IRC	Plan# 2600	2-story sfr w/attached garage	2013
New	Approved basic 13-107546 BP	2012 IRC	Plan# 2717	2-story sfr w/attached gara	2013
New	Approved basic 13-107546 BP	2012 IRC	Plan# 2717	2-story sfr w/attached gara	2013
New	Approved basic 13-106973 BP	2012 IRC	Plan# 448 A	2-story sfr w/attached garage	2013
New	Approved Basic 13-108399 BP.	2012 IRC.	Plan #467 B.	2 story sfr w/ attached ga	2013
New	Approved basic 13-110798.	2012 IRC.	Plan#4048.3.0C	2 story sfr w/ attached	2013
New	Approved basic 13-110330 BP	2012 IRC	Plan# 4153.3.0D	2-story sfr w/attachec	2013
New	Approved basic 13-106972 BP	2012 IRC	Plan# 446 A	2=story sfr w/attached garage	2013
New	Approved Basic 13-108398 BP.	2012 IRC.	Plan #448 B.	2 story sfr w/ attached gara	2013
New	Approved basic 13-111035 BP	2012 IRC	Plan# 455 AB	2-story sfr w/attached gara	2013
New	SFR, new 2 story home with attached 3 car garage and covered front porch				2013
New	Two Story SFR with Attached Garage				2013
New	Rambler style sfr w/attached garage				2013
New	Approved basic 13-109803 BP.	2012 IRC.	Plan # 33-30.12 F - Henley4.	2 story sfr w/ attach	2013
New	Approved basic 13-110883.	2012 IRC.	Plan # 32-30.02 V - Henley5.	2 story sfr w/ attached	2013
New	Approved basic 13-109805 BP.	2012 IRC.	Plan # 33-30.02 H - Henley4.	2 story sfr w/ att	2013

Accessory Dwelling Units

Index # - File Name: 1.0022 - Single Family Dwellings Data\_Snohomish County.pdf

New	Approved	basic 13-112082 BP	2012 IRC	Plan# 32-30.02 A- Henley7	2-story sfr w/attached	2013
New	Approved	basic 13-112081 BP	2012 IRC	Plan# 33-30.02 F2- Henley7	2-story sfr w/attached	2013
New		1980 sf rambler with attached garage				2013
New	Approved	basic 13-112656 BP.	2012 IRC.	Plan #34-30.02.	2 story sfr w/ attached garage.	2013
New	Approved	basic 13-109805 BP.	2012 IRC.	Plan # 33-30.02 H - Henley4.	2 story sfr w/ attached	2013
New	Approved	basic 13-110757 BP	2012 IRC	Plan# 34-30.02 P2 - Henley5	2-story sfr w/ attached	2013
New	Approved	basic 13-111321.	2012 IRC.	Plan # 33-30.02 F2.	2 story sfr w/ attached garage	2013
New	Approved	basic 13-113233 BP.	2012 IRC.	Plan #33-30.12 F2 - Henley10.	2 story sfr w/ attached	2013
New	Approved	basic 13-113235 BP.	2012 IRC.	Plan #31-30.02 V4 - Henley10.	2 story sfr w/ attached	2013
New		2-story sfr w/daylight basement w/attached garage				2013
New	Approved	basic 12-107463 BP	2009 IRC	Plan# B732-A	2-story sfr w/attached garage	2013
New	Approved	basic 10-107035 BP	2009 IRC	Plan# 3726-A	2-story sfr w/attached garage	2013
New	Approved	basic 10-106094 BP	2009 IRC	Plan# 3724-A	2-story sfr w/attached garage	2013
New	Approved	basic 10-108189 BP	2009 IRC	Plan# 4710-A	2-story sfr w/attached garage	2013
New	Approved	basic 11-102894 BP	2009 IRC	Plan# 3727-A	2-story sfr w/attached garage	2013
New	Approved	basic 10-108190 BP	2009 IRC	Plan# 4710-B	2-story sfr w/attached garage	2013
New	Approved	basic 12-102533 BP	2009 IRC	Plan#3733-A	2-story sfr w/attached garage	2013
New	Approved	basic 13-101858 BP	2009 IRC	Plan# 2200	2-story sfr w/attached garage	2013
New	Approved	Basic 13-102426.	IRC 2009.	Plan # 3014C.	2 story sfr w/ attached garage	2013
New	Approved	Basic 13-102430.	2009 IRC.	Plan # 3019A.	2 story sfr w/ attached garage	2013
New	Approved	basic 13-108754 BP.	2012 IRC.	Plan # 3722-A.	2 story sfr w/ attached garage	2013
New	Approved	basic 13-108745 BP.	2012 IRC.	Plan # 3815-A.	2 story sfr w/ attached garage	2013
New	Approved	basic 10-107750 BP	2009 IRC	Plan# 3706-B	2-story sfr w/attached garage	2013
New	Approved	basic 12-110816 BP	2009 IRC	Plan# 3705-B	2-story sfr w/attached garage	2013
New	Approved	basic 13-108693 BP	2012 IRC	Plan# 3904-B	2-story sfr w/attached garage	2013
New	Approved	Basic 13-108752 BP.	2012 IRC.	Plan # 3706 - A.	2 story sfr w/ attached garage	2013
New	Approved	Basic 13-108752 BP.	2012 IRC.	Plan # 3706 - A.	2 story sfr w/ attached garage	2013
New	Approved	basic 13-108693 BP	2012 IRC	Plan# 3904-B	2-story sfr w/attached garage	2013
New	Approved	basic 13-108751 BP.	2012 IRC.	Plan # 3706 - B.	2 story sfr w/ attached garage	2013
New	Approved	Basic 13-108748 BP.	2012 IRC.	Plan # 3705-B.	2 story sfr w/ attached garage.	2013
New	Approved	basic 13-108692 BP	2012 IRC	Plan# 3904-A	2-story sfr w/attached garage	2013
New	Approved	basic 10-107749 BP	2009 IRC	Plan# 3706-A	2-story sfr w/attached garage	2013
New	Approved	basic 12-110736 BP	2009 IRC	Plan# 3728-A	2-story sfr w/attached garage	2013
New	Approved	basic 10-106095 BP	2009 IRC	Plan # 3724-B	2-story sfr w/attached garage	2013
New	Approved	Basic 13-108750 BP.	2012 IRC.	Plan # 3705-A.	2 story sfr w/ attached garage	2013
New	Approved	basic 11-103499 BP	2009 IRC	Plan# 3904-B	2-story sfr w/attached garage	2013
New	Approved	basic 12-104802 BP	2009 IRC	Plan# 3815-A	2-story sfr w/attached garage	2013
New	Approved	basic 11-103498 BP	2009 IRC	Plan# 3904-A	2-story sfr w/attached garage	2013
New	Approved	basic 10-108094 BP	2009 IRC	Plan# 3705-AB	2-story sfr w/attached garage	2013
New	Approved	basic 10-107750 BP	2009 IRC	Plan# 3706-B	2-story sfr w/attached garage	2013
New	Approved	basic 10-107750 BP	2009 IRC	Plan# 3706-B	2-story sfr w/attached garage	2013
New	Approved	basic 11-103499 BP	2009 IRC	Plan# 3904-B	2-story sfr w/attached garage	2013
New	Approved	basic 10-107749 BP	2009 IRC	Plan# 3706-A	2-story sfr w/attached garage	2013
New	Approved	basic 12-110816 BP	2009 IRC	Plan# 3705-B	2-story sfr w/attached garage	2013
New	Approved	basic 10-107750 BP	2009 IRC	Plan# 3706-B	2-story sfr w/attached garage	2013
New		2 story sfr w/ attached garage and daylight basement				2013
New		2 story sfr w/ attached garage and daylight basement				2013

Accessory Dwelling Units

Index # - File Name: 1.0022 - Single Family Dwellings Data\_Snohomish County.pdf

New	2 story sfr w/ attached garage and daylight basement					2013
New	2 story sfr w/ attached garage and daylight basement					2013
New	2 story sfr w/ attached garage and daylight basement					2013
New	Approved Basic 13-108750 BP.	2012 IRC.	Plan # 3705-A.	2 story sfr w/ attached		2013
New	Approved basic 13-108751 BP.	2012 IRC.	Plan # 3706 - B.	2 story sfr w/ attached		2013
New	Approved basic 12-108551 BP	2009 IRC	Plan# 3729-B	2-story sfr w/attached ga		2013
New	Approved basic 10-106094 BP	2009 IRC	Plan# 3724-A	2-story sfr w/attached gara		2013
New	Approved basic 12-108551 BP	2009 IRC	Plan# 3729-B	2-story sfr w/attached ga		2013
New	Approved basic 12-102533 BP	2009 IRC	Plan#3733-A	2-story sfr w/attached g		2013
New	Approved basic 10-107465 BP	2009 IRC	Plan# 3722-A	2-story sfr w/attached gara		2013
New	Approved basic 12-108549 BP	2009 IRC	Plan# 3729-A	2-story sfr w/attached g		2013
New	Approved basic 10-106095 BP	2009 IRC	Plan # 3724-B	2-story sfr w/attached garag		2013
New	Approved basic 12-100737 BP	2009 IRC	Plan # 3728-B	2-story sfr w/attached gara		2013
New	Approved basic 12-102534 BP	2009 IRC	Plan# 3733-B	2-story sfr w/attached gara		2013
New	Approved basic 12-108549 BP	2009 IRC	Plan# 3729-A	2-story sfr w/attached g		2013
New	Approved basic 12-102534 BP	2009 IRC	Plan# 3733-B	2-story sfr w/attached gara		2013
New	Approved basic 10-107466 BP	2009 IRC	Plan# 3722-B	2-story sfr w/attached garage		2013
New	Approved basic 12-108551 BP	2009 IRC	Plan# 3729-B	2-story sfr w/attached ga		2013
New	Approved basic 10-106094 BP	2009 IRC	Plan# 3724-A	2-story sfr w/attached gara		2013
New	Approved Basic 13-108747 BP.	2012 IRC.	Plan# 3728-A.	2 Story sfr w/ attached		2013
New	Approved basic 13-108689 BP	2012 IRC	Plan#3733-A	2-story sfr w/attached gara		2013
New	Approved basic 13-108682 BP.	2012 IRC.	Plan # 3724-B.	2 story sfr w/ attache		2013
New	Approved basic 13-108687 BP.	2012 IRC.	Plan # 3729-B.	2 story sfr w/ attache		2013
New	Approved basic 11-103498 BP	2009 IRC	Plan# 3904-A	2-story sfr w/attached g		2013
New	Approved basic 10-106095 BP	2009 IRC	Plan # 3724-B	2-story sfr w/attached garag		2013
New	2 story sfr w/ attached garage and daylight basement					2013
New	2 story sfr w/ attached garage and daylight basement					2013
New	2 story sfr w/ attached garage and daylight basement					2013
New	Approved basic 13-103528 BP	2009 IRC	Plan# 4035B	2-story sfr w/attached gar		2013
New	Approved basic 13-103525 BP	2009 IRC	Plan# 4028B	2-story sfr w/attached ga		2013
New	Approved Basic 13-105072 BP	2009 IRC.	Plan # 4023C.	2 story sfr w/ attached ga		2013
New	Approved basic 13-103527 BP	2009 IRC	Plan# 4035A	2-story sfr w/attached gar		2013
New	Approved basic 13-103524 BP	2009 IRC	Plan# 4028A	2-story sfr w/attached ga		2013
New	Approved basic 13-105070.	2009 IRC.	Plan #4023-A.	2 story sfr w/ attach		2013
New	Approved basic 13-103528 BP	2009 IRC	Plan# 4035B	2-story sfr w/attached gar		2013
New	Approved basic 13-105071.	2009 IRC.	Plan #4023B.	2 story sfr w/ attached garage. Tabl		2013
New	Approved basic 13-103525 BP	2009 IRC	Plan# 4028B	2-story sfr w/attached ga		2013
New	Approved basic 13-103527 BP	2009 IRC	Plan# 4035A	2-story sfr w/attached gar		2013
New	Approved Basic 13-105072 BP	2009 IRC.	Plan # 4023C.	2 story sfr w/ attached ga		2013
New	Approved basic 13-103526 BP	2009 IRC	Plan# 4028C	2-story sfr w/attached garage		2013
New	Approved basic 13-103528 BP	2009 IRC	Plan# 4035B	2-story sfr w/attached gar		2013
New	Approved basic 13-103526 BP	2009 IRC	Plan# 4028C	2-story sfr w/attached garage		2013
New	Approved basic 13-105070.	2009 IRC.	Plan #4023-A.	2 story sfr w/ attach		2013
New	Approved basic 13-103527 BP	2009 IRC	Plan# 4035A	2-story sfr w/attached gar		2013
New	Approved basic 13-103524 BP	2009 IRC	Plan# 4028A	2-story sfr w/attached ga		2013
New	Approved basic plan 13-103529 BP	2009 IRC	Plan#4035C	2-story sfr w/attached		2013
New	Approved basic 13-105071.	2009 IRC.	Plan #4023B.	2 story sfr w/ attached garage. Tabl		2013

Accessory Dwelling Units

Index # - File Name: 1.0022 - Single Family Dwellings Data\_Snohomish County.pdf

New	Approved	basic 13-103528 BP	2009 IRC	Plan# 4035B	2-story sfr w/attached gar	2013
New	Approved	basic 13-103525 BP	2009 IRC	Plan# 4028B	2-story sfr w/attached ga	2013
New	Approved	basic 13-103527 BP	2009 IRC	Plan# 4035A	2-story sfr w/attached gar	2013
New	Approved	basic 13-103526 BP	2009 IRC	Plan# 4028C	2-story sfr w/attached garage	2013
New	Approved	basic plan 13-103529 BP	2009 IRC	Plan#4035C	2-story sfr w/attached	2013
New	Approved	basic 13-105071.	2009 IRC.	Plan #4023B.	2 story sfr w/ attached garage.	Tabl 2013
New	Approved	basic 13-103527 BP	2009 IRC	Plan# 4035A	2-story sfr w/attached gar	2013
New	Approved	basic 13-103526 BP	2009 IRC	Plan# 4028C	2-story sfr w/attached garage	2013
New	Approved	basic 13-105071.	2009 IRC.	Plan #4023B.	2 story sfr w/ attached garage.	Tabl 2013
New	Approved	basic 13-103526 BP	2009 IRC	Plan# 4028C	2-story sfr w/attached garage	2013
New	Approved	basic 13-103528 BP	2009 IRC	Plan# 4035B	2-story sfr w/attached gar	2013
New	Approved	basic 13-105070.	2009 IRC.	Plan #4023-A.	2 story sfr w/ attach	2013
New	Approved	basic plan 13-103529 BP	2009 IRC	Plan#4035C	2-story sfr w/attached	2013
New	Approved	basic 13-103524 BP	2009 IRC	Plan# 4028A	2-story sfr w/attached ga	2013
New	Approved	basic 13-103527 BP	2009 IRC	Plan# 4035A	2-story sfr w/attached gar	2013
New	Approved	basic 13-103526 BP	2009 IRC	Plan# 4028C	2-story sfr w/attached garage	2013
New	Approved	basic 13-103528 BP	2009 IRC	Plan# 4035B	2-story sfr w/attached gar	2013
New	Approved	basic 13-103526 BP	2009 IRC	Plan# 4028C	2-story sfr w/attached garage	2013
New	Approved	basic 13-101858 BP	2009 IRC	Plan# 2200	2-story sfr w/attached }	2013
New	Approved	basic 12-109466 BP	2009 IRC	Plan # Jupiter 2005	2-story sfr w/attach	2013
New	Approved	basic 12-109465 BP	2009 IRC	Plan# June 1866	Rambler style sfr w/i	2013
New	Approved	basic 12-109466 BP	2009 IRC	Plan # Jupiter 2005	2-story sfr w/attach	2013
New	Approved	basic 12-109465 BP	2009 IRC	Plan# June 1866	Rambler style sfr w/i	2013
New	Approved	basic 13-101858 BP	2009 IRC	Plan# 2200	2-story sfr w/attached }	2013
New	Approved	basic 12-110563 BP	2009 IRC	Plan# Julia Grande	2-story sfr w/attac	2013
New	Approved	basic 12-104440 BP	2009 IRC	Plan# 2146	2-story sfr w/attached garag	2013
New		2 story sfr w/ daylight basement and attached gargage.				2013
New		2 story sfr w/ daylight basement				2013
New		2 story sfr w/ attached garage and daylight basement				2013
New		2 story sfr w/ attached garage.				2013
New		2 story sfr w/ daylight basement and attached garage.				2013
New		2 story sfr attached garage and daylight basement				2013
New		2 story sfr w/ attached garage and daylight basement.				2013
New	Approved	basic 10-107468 BP	2009 IRC	Plan# 3725-B	2-story sfr w/attached gara	2013
New	Approved	basic 10-107035 BP	2009 IRC	Plan# 3726-A	2-story sfr w/attached ga	2013
New	Approved	basic 10-108190 BP	2009 IRC	Plan# 4710-B	2-story sfr w/attached gara	2013
New	Approved	basic 10-107036 BP	2009 IRC	Plan # 3726-B	2-story sfr w/attached garage	2013
New	Approved	basic 13-100488 BP	2009 IRC	Plan# 4008-B	2-story sfr w/attached gar	2013
New	Approved	basic 10-108189 BP	2009 IRC	Plan# 4710-A	2-story sfr w/attached gara	2013
New	Approved	basic 12-103206 BP	2009 IRC	Plan# 3725W-B	2-story sfr w/attache	2013
New	Approved	basic 13-100485 BP	2009 IRC	Plan# 4008-A	2-story sfr w/attached gar	2013
New	Approved	basic 10-108190 BP	2009 IRC	Plan# 4710-B	2-story sfr w/attached gara	2013
New	Approved	basic 10-107035 BP	2009 IRC	Plan# 3726-A	2-story sfr w/attached ga	2013
New	Approved	basic 13-100488 BP	2009 IRC	Plan# 4008-B	2-story sfr w/attached gar	2013
New	Approved	basic 10-108189 BP	2009 IRC	Plan# 4710-A	2-story sfr w/attached gara	2013
New	Approved	basic 12-102534 BP	2009 IRC	Plan# 3733-B	2-story sfr w/attached gara	2013
New	Approved	basic 13-100485 BP	2009 IRC	Plan# 4008-A	2-story sfr w/attached gar	2013

Accessory Dwelling Units

Index # - File Name: 1.0022 - Single Family Dwellings Data\_Snohomish County.pdf

New	Approved basic 10-108094 BP	2009 IRC	Plan# 3705-AB	2-story sfr w/attached ga	2013
New	Approved basic 10-107465 BP	2009 IRC	Plan# 3722-A	2-story sfr w/attached gara	2013
New	Approved basic 10-106094 BP	2009 IRC	Plan# 3724-A	2-story sfr w/attached gara	2013
New	Approved basic 12-110736 BP	2009 IRC	Plan# 3728-A	2-story sfr w/attaced garag	2013
New	Approved basic 10-107466 BP	2009 IRC	Plan# 3722-B	2-story sfr w/attached garage	2013
New	Approved basic 12-108551 BP	2009 IRC	Plan# 3729-B	2-story sfr w/attached ga	2013
New	Approved basic 10-107466 BP	2009 IRC	Plan# 3722-B	2-story sfr w/attached garage	2013
New	Approved basic 10-106095 BP	2009 IRC	Plan # 3724-B	2-story sfr w/attached garag	2013
New	Approved basic 12-110736 BP	2009 IRC	Plan# 3728-A	2-story sfr w/attaced garag	2013
New	Approved basic 12-108549 BP	2009 IRC	Plan# 3729-A	2-story sfr w/attached g	2013
New	Approved basic 12-102534 BP	2009 IRC	Plan# 3733-B	2-story sfr w/attached gara	2013
New	Approved basic 10-106095 BP	2009 IRC	Plan # 3724-B	2-story sfr w/attached garag	2013
New	Approved basic 10-107465 BP	2009 IRC	Plan# 3722-A	2-story sfr w/attached gara	2013
New	Approved basic 10-107749 BP	2009 IRC	Plan# 3706-A	2-story sfr w/attached gara	2013
New	Approved basic 12-110816 BP	2009 IRC	Plan# 3705-B	2-story sfr w/attached	2013
New	Approved basic 11-103498 BP	2009 IRC	Plan# 3904-A	2-story sfr w/attached g	2013
New	Approved basic 11-103497 BP	2009 IRC	Plan# 3903-B	2-story sfr w/attached g	2013
New	Approved basic 13-100872.	2009 IRC.	Plan # 2832-02 AB	2 story sfr w/ attached g	2013
New	Approved basic 12-105541 BP	2009 IRC	Plan#2512-02AB	2-story sfr w/attache	2013
New	Approved basic 11-100555 BP	2009 IRC	Plan# 3310-03AB	2-story sfr w/attached gar	2013
New	Approved basic 11-104655 BP	2009 IRC	Plan# 2749-43AB	2-story sfr w/attached g	2013
New	Approved basic 11-100555 BP	2009 IRC	Plan# 3310-03AB	2-story sfr w/attached gar	2013
New	Approved basic 11-100555 BP	2009 IRC	Plan# 3310-03AB	2-story sfr w/attached gar	2013
New	Approved Basic 13-100872.	IRC 2009.	Plan # 2832-02AB.	2 story sfr w/ attached	2013
New	One story SFR with attached garage - 2009 IRC				2013
New	27 x 66 2013 First Edition				2013
New	Two Story home with attached 2-car garage (3 bedrooms)				2013
New	Approved basic 11-109777 BP	2009 IRC	Plan# Sinclair-A	2-story sfr w/attached g	2013
New	Approved basic 11-109776 BP	2009 IRC	Plan# San Juan-A	2-story sfr w/attached g	2013
New	Approved basic 11-100307 BP	2009 IRC	Plan# Blakely B-3 car	2-story sfr w/attache	2013
New	Approved basic 10-105538 BP	2009 IRC	Plan# Chelan II A	2-story sfr w/attached g	2013
New	Approved basic 12-104680 BP	2009 IRC	Plan# Mason-B	2-story sfr w/attache	2013
New	Approved basic 10-106095 BP	2009 IRC	Plan # 3724-B	2-story sfr w/attached garag	2013
New	Approved basic 10-107462 BP	2009 IRC	Plan# 3720-B	2-story sfr w/attached gara	2013
New	Approved basic 12-102534 BP	2009 IRC	Plan# 3733-B	2-story sfr w/attached gara	2013
New	Approved basic 10-107036 BP	2009 IRC	Plan # 3726-B	2-story sfr w/attached garage	2013
New	Approved basic 12-108551 BP	2009 IRC	Plan# 3729-B	2-story sfr w/attached ga	2013
New	Approved basic 11-102895 BP	2009 IRC	Plan# 3727-B	2-story sfr w/attached gara	2013
New	Approved basic 12-102534 BP	2009 IRC	Plan# 3733-B	2-story sfr w/attached gara	2013
New	Approved basic 10-106093 BP	2009 IRC	Plan# 3723-AB	2-story sfr w/attached garag	2013
New	Approved basic 12-110650 BP	2009 IRC	Plan# 20-30.12 M CREEKSTONE	2-story	2013
New	Approved basic 12-110325 BP	2009 IRC	Plan# 19-30.02 H Creekstone	2-story sfr v	2013
New	Approved basic 12-110651 BP	2009 IRC	Plan# 5-40.02 G (.1) CREEKSTONE	2-	2013
New	2-story sfr w/attached garage				2013
New	2-story sfr w/attached garage				2013
New	2-story sfr w/attached garage				2013
New	Approved basic 12-110324 BP	2009 IRC	Plan# 1-40.02 E Creekstone	2-story	2013

Accessory Dwelling Units

Index # - File Name: 1.0022 - Single Family Dwellings Data\_Snohomish County.pdf

New	SFR, two story with attached two car garage and covered porch				2013
New	2 story sfr w/attached garage and unfinished basement - 2009 IRC.				2013
New	New house, Two story with finished basement, attached 2 car garage and covered front porch (				2013
New	Approved basic 12-103771 BP	2009 IRC	Plan# 2612A	2-story sfr w/attached ga	2013
New	Approved basic 12-102813 BP	2009 IRC	Plan# Greenbank 2895	2-story sfr w/attach	2013
New	Approved basic 12-102810 BP	2009	Plan# Langley 2254	Rambler Style sfr w/atti	2013
New	Approved basic 12-102813 BP	2009 IRC	Plan# Greenbank 2895	2-story sfr w/attach	2013
New	Approved basic 12-102813 BP	2009 IRC	Plan# Greenbank 2895	2-story sfr w/attach	2013
New	Approved basic 12-102813 BP	2009 IRC	Plan# Greenbank 2895	2-story sfr w/attach	2013
New	Approved basic 12-102813 BP	2009 IRC	Plan# Greenbank 2895	2-story sfr w/attach	2013
New	New SFR w/ attached garage. See 13-104693-LDA.				2013
New	new 2-story SFR with attached garage				2013
New	SFR, two - story home with 3 car garage and covered front porch				2013
New	New 2- story SFR with attached garage				2013
New	2-story sfr w/attached garage				2013
New	Two Story SFR with 544SF of Covered Porch				2013
New	Approved basic 13-108542 BP.	2012 IRC.	Plan #35-30.02 T4.	2 story sfr w/ attached ga	2013
New	2-story sfr w/attached garage				2013
New	Approved basic 13-112362 BP	2012 IRC	Plan# Juanita	2-story sfr w/a	2013
New	Approved basic 13-112361 BP	2012 IRC	Plan# West Point	2-story sfr w/i	2013
New	Approved basic 13-109989 BP	2012 IRC	Plan# Alki	2-story sfr w/attached ga	2013
New	Approved basic 13-109990 BP	2012 IRC	Plan# Andrews	2-story sfr w/attached ga	2013
New	Approved basic 13-109607 BP	2012 IRC	Plan# 3727-A	2-story sfr w/attached gar	2013
New	Approved basic 13-10684 BP.	2012 IRC.	Plan # 3726-B.	2 story sfr w/ attached garag	2013
New	Approved basic 13-108687 BP.	2012 IRC.	Plan # 3729-B.	2 story sfr w/ attache	2013
New	Approved basic 13-108681 BP.	2012 IRC.	Plan # 3724 A.	2 story sfr w/ attache	2013
New	Approved basic 13-111761 BP	2012 IRC	Plan# B722-B	2-story sfr w/attached g	2013
New	Approved basic 13-111073 BP	2012 IRC	Plan# B720-B	2-story sfr w/attached	2013
New	Approved basic 13-111304 BP	2012 IRC	Plan# 2486	2-story sfr w/attached garag	2013
New	Approved basic 13-111305 BP	2012 IRC	Plan# 3297	2-story sfr w/attached	2013
New	Two Story SFR with Attached Garage				2013
New	Approved basic 13-111033 BP.	2012 IRC.	Plan #3104.	2 story sfr w/ attache	2013
New	Approved basic 13-111027 BP.	2012 IRC.	Plan 2992.	2 story sfr w/ attache	2013
New	Approved basic 13-111033 BP.	2012 IRC.	Plan #3104.	2 story sfr w/ attache	2013
New	Approved basic 13-111033 BP.	2012 IRC.	Plan #3104.	2 story sfr w/ attache	2013
New	Approved basic 10-107171 BP	2009 IRC	Plan# Chellan II-A (3 Car)	2-story sfr w/atta	2013
New	Two-story SFR - 2009 IRC				2013
New	Approved basic 10-105761	2009 IRC	Plan# Possession Lane Plan	2-story sfr w/attached ga	2013
New	Approved basic 10-105761	2009 IRC	Plan# Possession Lane Plan	2-story sfr w/attached ga	2013
New	SFR, new two story home with attached two car garage and covered porch, 3 bedrooms				2013
New	2-story sfr w/attached garage				2013
New	Approved basic 10-105761	2009 IRC	Plan# Possession Lane Plan	2-story sfr w/attached ga	2013
New	Approved basic 10-105761	2009 IRC	Plan# Possession Lane Plan	2-story sfr w/attached ga	2013
New	Two Strory SFR with Attached Garage				2013
New	Approved basic 12-103588 BP	2009 IRC	Plan# 1640	2-story sfr w/attached garage	2013
New	Rambler style sfr w/attached garage				2013
New	Rambler style home with 3 car garage and covered front porch (3 bed/2 bath)				2013



Accessory Dwelling Units

Index # - File Name: 1.0022 - Single Family Dwellings Data\_Snohomish County.pdf

New	Approved basic 11-102545 BP	2009 IRC	Plan# Barclay A	3-story sfr w/attached ga	2013
New	Approved basic 11-105360 BP	2009 IRC	Plan# Cascade-B 3 car	2-story sfr w/attached ga	2013
New	Approved basic 10-105529 BP	2009 IRC	Plan# Baker A	2-story sfr w/attached ga	2013
New	Approved basic 10-105538 BP	2009 IRC	Plan# Chelan II A	2-story sfr w/attached ga	2013
New	Approved basic 12-104680 BP	2009 IRC	Plan# Mason-B	2-story sfr w/attached ga	2013
New	Approved basic 12-100084 BP	2009 IRC	Plan# Baker-B	3-story sfr w/attached garage	2013
New	Approved basic 10-107171 BP	2009 IRC	Plan# Chellan II-A (3 Car)	2-story sfr w/attached ga	2013
New	Approved basic 12-100084 BP	2009 IRC	Plan# Baker-B	3-story sfr w/attached garage	2013
New	Approved basic 10-105540 BP	2009 IRC	Plan# Cascade B	2-story sfr w/attached ga	2013
New	2 stroy SFR w/ finished basement & attached garage				2013
New	Approved basic 11-102545 BP	2009 IRC	Plan# Barclay A	3-story sfr w/attached ga	2013
New	Approved basic 11-102548 BP	2009 IRC	Plan# Decatur A	3-story sfr w/attached ga	2013
New	Approved basic 11-105854 BP	2009 IRC	Plan# Windom-B	3-story sfr w/attached ga	2013
New	Approved basic 12-100084 BP	2009 IRC	Plan# Baker-B	3-story sfr w/attached garage	2013
New	SFR, rambler style home with attached 3 car garage, (3 bed)				2013
New	Approved basic 10-107475 BP	2009 IRC	Plan# Franklin B	2-story sfr w/attached ga	2013
New	Approved basic 11-102547 BP	2009 IRC	Plan# Skagit A	2-story sfr w/attached ga	2013
New	Approved basic 11-105360 BP	2009 IRC	Plan# Cascade-B 3 car	2-story sfr w/attached ga	2013
New	Approved basic 13-103453 BP	2009 IRC	Plan# Orcas II-A	2-story sfr w/attached ga	2013
New	Approved basic 10-106958 BP	2009 IRC	Plan# Rainier B	2-story sfr w/attached ga	2013
New	SFR, rambler style home with attached 3 car garage, (3 bed)				2013
New	One-story sfr with attached garage - 2012-IRC				2013
New	Approved Basic 13-100884 BP	2009 IRC	. Plan # 20-30.02M (.2) HENLEY.	2 story sfr w/ attached ga	2013
New	Approved Basic 13-100883 BP	2009 IRC	Plan #19-30.02C HENLEY.	2 story sfr w/ attached ga	2013
New	Approved basic 13-102515 BP	2009 IRC	Plan# 20-30.02 E (.2) HENLEY	2-story sfr w/ attached ga	2013
New	Approved basic 13-101829 BP	2009 IRC	Plan# 19-30.02 D HENLEY	2-story sfr w/ attached ga	2013
New	Approved Basic 13-100883 BP	2009 IRC	Plan #19-30.02C HENLEY.	2 story sfr w/ attached ga	2013
New	Approved Basic 13-104366 BP.	2009 IRC.	Plan # 18.30.02 M (.1) - Henley.	2 story sfr w/ attached ga	2013
New	Approved basic 13-100148 BP	2009 IRC	Plan# 28-30.12 F(.1) - HENLEY	2-story sfr w/ attached ga	2013
New	Approved basic 13-101742 BP	2009 IRC	Plan# 3054-40-9	2-story sfr w/attached ga	2013
New	Approved basic 13-101742 BP	2009 IRC	Plan# 3054-40-9	2-story sfr w/attached ga	2013
New	Approved basic 13-101742 BP	2009 IRC	Plan# 3054-40-9	2-story sfr w/attached ga	2013
New	Approved basic 12-110054 BP	2009 IRC	Plan# 1922/2	2-story sfr w/attached ga	2013
New	Approved basic 12-110052 BP	2009 IRC	Plan# 2536/2	2-story sfr w/attached ga	2013
New	Approved basic 12-110055 BP	2009 IRC	Plan# 2683/2	2-story sfr w/attached ga	2013
New	2-story sfr w/attached garage				2013
New	Approved basic 13-107236 BP	2009 IRC	Plan# 2457/2DB	Rambler style attached garage	2013
New	Approved basic 13-107236 BP	2009 IRC	Plan# 2457/2DB	Rambler style attached garage	2013
New	Approved basic 13-107236 BP	2009 IRC	Plan# 2457/2DB	Rambler style attached garage	2013
New	Approved basic 13-107236 BP	2009 IRC	Plan# 2457/2DB	Rambler style attached garage	2013
New	Approved basic 12-110050 BP	2009 IRC	Plan# 2417/2	2-story sfr w/attached ga	2013
New	Approved basic 12-110042 BP	2009 IRC	Plan# 2885/2	2-story sfr w/attached garage	2013
New	Approved basic 12-110042 BP	2009 IRC	Plan# 2885/2	2-story sfr w/attached garage	2013
New	Approved basic 12-110052 BP	2009 IRC	Plan# 2536/2	2-story sfr w/attached ga	2013
New	Approved basic 12-110050 BP	2009 IRC	Plan# 2417/2	2-story sfr w/attached ga	2013
New	Approved basic 12-110052 BP	2009 IRC	Plan# 2536/2	2-story sfr w/attached ga	2013
New	Approved basic 12-110444 BP	2009 IRC	Plan# 2198/2	2-story sfr w/attached garage	2013

Accessory Dwelling Units

Index # - File Name: 1.0022 - Single Family Dwellings Data\_Snohomish County.pdf

New	Approved	basic 12-110052 BP	2009 IRC	Plan# 2536/2	2-story sfr w/attach	2013
New	Approved	basic 12-110050 BP	2009 IRC	Plan# 2417/2	2-story sfr w/attached	2013
New	Approved	basic 13-103284 BP	2009 IRC	Plan#2975/2	2-story sfr w/attached garag	2013
New	Approved	basic 12-110055 BP	2009 IRC	Plan# 2683/2	2-story sfr w/attached	2013
New	Approved	basic 12-110055 BP	2009 IRC	Plan# 2683/2	2-story sfr w/attach	2013
New	Approved	basic 12-110444 BP	2009 IRC	Plan# 2198/2	2-story sfr w/attached gara	2013
New	Approved	basic 11-107564 BP	2009 IRC	Plan# 2202	2-story sfr w/attached gar	2013
New	Approved	basic 11-107564 BP	2009 IRC	Plan# 2202	2-story sfr w/attached gar	2013
New	Approved	basic 12-105524 BP	2009 IRC	Plan# 2304	2-story sfr w/attached garag	2013
New	Approved	basic 13-101740 BP	2009 IRC	Plan# 2710-30-9	2-story sfr w/attached	2013
New	Approved	basic 12-108643 BP	2009 IRC	Plan# 2777	2-story sfr w/attached gara	2013
New	Approved	basic 13-101740 BP	2009 IRC	Plan# 2710-30-9	2-story sfr w/attached	2013
New	Approved	basic 12-108643 BP	2009 IRC	Plan# 2777	2-story sfr w/attached gara	2013
New	2 story sfr w/ attached garage.					2013
New	Approved	basic 12-108643 BP	2009 IRC	Plan# 2777	2-story sfr w/attached gara	2013
New	Approved	basic 10-109376 BP	2009 IRC	Plan# 2230-50-8	2-story sfr w/attached gar	2013
New	Approved	basic 12-100357 BP	2009 IRC	Plan# 2279-30-8	2-story sfr w/attached ga	2013
New	Approved	basic 13-101742 BP	2009 IRC	Plan# 3054-40-9	2-story sfr w/attache	2013
New	Approved	basic 13-101740 BP	2009 IRC	Plan# 2710-30-9	2-story sfr w/attached	2013
New	Approved	basic 13-101740 BP	2009 IRC	Plan# 2710-30-9	2-story sfr w/attached	2013
New	Approved	basic 12-100357 BP	2009 IRC	Plan# 2279-30-8	2-story sfr w/attached ga	2013
New	Approved	basic 13-101740 BP	2009 IRC	Plan# 2710-30-9	2-story sfr w/attached	2013
New	Approved	basic 12-108641 BP	2009 IRC	Plan# 2557	2-story sfr w/attached gara	2013
New	Approved	basic 13-101740 BP	2009 IRC	Plan# 2710-30-9	2-story sfr w/attached	2013
New	Approved	basic 12-108643 BP	2009 IRC	Plan# 2777	2-story sfr w/attached gara	2013
New	Approved	basic 12-108642 BP	2009 IRC	Plan# 2102	2-story sfr w/attached garage	2013
New	Approved	basic 11-107552 BP	2009 IRC	Plan# 2162	2-story sfr w/attached garag	2013
New	Approved	basic 11-107552 BP	2009 IRC	Plan# 2162	2-story sfr w/attached garag	2013
New	Approved	basic 11-107564 BP	2009 IRC	Plan# 2202	2-story sfr w/attached gar	2013
New	Approved	basic 11-107552 BP	2009 IRC	Plan# 2162	2-story sfr w/attached garag	2013
New	Approved	basic 12-105524 BP	2009 IRC	Plan# 2304	2-story sfr w/attached garag	2013
New	Approved	basic 11-107552 BP	2009 IRC	Plan# 2162	2-story sfr w/attached garag	2013
New	Approved	basic 11-107552 BP	2009 IRC	Plan# 2162	2-story sfr w/attached garag	2013
New	Approved	basic 11-107551 BP	2009 IRC	Plan# 2244	2-story sfr w/attached garage	2013
New	Approved	basic 11-107562 BP	2009 IRC	Plan# 2074	2-story sfr w/attached gara	2013
New	Permit to change plan to Approved	basic 12-105524 BP	2009 IRC	Plan# 2304	2-s	2013
New	Approved	basic 13-101742 BP	2009 IRC	Plan# 3054-40-9	2-story sfr w/attache	2013
New	Approved	basic 13-101742 BP	2009 IRC	Plan# 3054-40-9	2-story sfr w/attache	2013
New	Approved	basic 13-101740 BP	2009 IRC	Plan# 2710-30-9	2-story sfr w/attached	2013
New	Approved	basic 13-105550 BP	2009 IRC	Plan# 3010-30-9	2-story sfr w/TUCK under ga	2013
New	Approved	basic 13-105551 BP	2009 IRC	Plan# 3111-30-9	2-story sfr w/TUCK UNDER	2013
New	Approved	basic 13-105550 BP	2009 IRC	Plan# 3010-30-9	2-story sfr w/TUCK under ga	2013
New	Approved	basic 13-105551 BP	2009 IRC	Plan# 3111-30-9	2-story sfr w/TUCK UNDER	2013
New	Approved	basic 13-105550 BP	2009 IRC	Plan# 3010-30-9	2-story sfr w/TUCK under ga	2013
New	Approved	basic 13-105551 BP	2009 IRC	Plan# 3111-30-9	2-story sfr w/TUCK UNDER	2013
New	Approved	basic 13-105550 BP	2009 IRC	Plan# 3010-30-9	2-story sfr w/TUCK under ga	2013
New	Approved	basic 12-100231 BP	2009 IRC	Plan# 3019 A	2-story sfr w/attached	2013

Accessory Dwelling Units

Index # - File Name: 1.0022 - Single Family Dwellings Data\_Snohomish County.pdf

New	Approved basic 12-100230 BP	2009 IRC	Plan# 3014 C	2-story sfr w/attached garage	2013
New	Approved basic 12-100228 BP	2009 IRC	Plan# 3013 C	2-story sfr w/attached garage	2013
New	Approved basic 12-100232 BP	2009 IRC	Plan # 3019 C	2-story sfr w/attached garage	2013
New	Approved basic 12-100229 BP	2009 IRC	Plan# 3014 B	2-story sfr w/attached garage	2013
New	Approved basic 12-100228 BP	2009 IRC	Plan# 3013 C	2-story sfr w/attached garage	2013
New	Approved basic 12-100231 BP	2009 IRC	Plan# 3019 A	2-story sfr w/attached garage	2013
New	Approved basic 12-100230 BP	2009 IRC	Plan# 3014 C	2-story sfr w/attached garage	2013
New	Approved basic 12-100224 BP	2009 IRC	Plan# 3013 A	2-story sfr w/attached garage	2013
New	Approved basic 12-100229 BP	2009 IRC	Plan# 3014 B	2-story sfr w/attached garage	2013
New	Approved basic 13-103553 BP	2009 IRC	Plan# 2546	Rambler style sfr w/attached garage	2013
New	Approved basic 13-103550 BP	2009 IRC	Plan# 3750	2-story sfr w/attached garage	2013
New	Approved basic 13-103553 BP	2009 IRC	Plan# 2546	Rambler style sfr w/attached garage	2013
New	Approved basic 13-103766 BP	2009 IRC	Plan# M3180	2-story sfr w/attached garage	2013
New	Approved basic 13-103553 BP	2009 IRC	Plan# 2546	Rambler style sfr w/attached garage	2013
New	Approved basic 13-103766 BP	2009 IRC	Plan# M3180	2-story sfr w/attached garage	2013
New	Approved basic 13-103550 BP	2009 IRC	Plan# 3750	2-story sfr w/attached garage	2013
New	2-story sfr w/attached garage				2013
New	Approved basic 13-103766 BP	2009 IRC	Plan# M3180	2-story sfr w/attached garage	2013
New	Approved basic 13-103553 BP	2009 IRC	Plan# 2546	Rambler style sfr w/attached garage	2013
New	Approved basic 13-103550 BP	2009 IRC	Plan# 3750	2-story sfr w/attached garage	2013
New	Approved basic 13-100872.	2009 IRC.	Plan # 2832-02 AB	2 story sfr w/ attached garage	2013
New	2-story sfr w/attached garage				2013
New	Approved basic 12-100231 BP	2009 IRC	Plan# 3019 A	2-story sfr w/attached garage	2013
New	Approved basic 12-100229 BP	2009 IRC	Plan# 3014 B	2-story sfr w/attached garage	2013
New	Approved basic 12-100224 BP	2009 IRC	Plan# 3013 A	2-story sfr w/attached garage	2013
New	Approved basic 12-100228 BP	2009 IRC	Plan# 3013 C	2-story sfr w/attached garage	2013
New	Approved basic 12-100232 BP	2009 IRC	Plan # 3019 C	2-story sfr w/attached garage	2013
New	Approved basic 12-100228 BP	2009 IRC	Plan# 3013 C	2-story sfr w/attached garage	2013
New	Approved basic 12-100231 BP	2009 IRC	Plan# 3019 A	2-story sfr w/attached garage	2013
New	Approved basic 12-100230 BP	2009 IRC	Plan# 3014 C	2-story sfr w/attached garage	2013
New	Approved basic 12-100224 BP	2009 IRC	Plan# 3013 A	2-story sfr w/attached garage	2013
New	Approved basic 12-100232 BP	2009 IRC	Plan # 3019 C	2-story sfr w/attached garage	2013
New	Approved Basic 13-100872.	IRC 2009.	Plan # 2832-02AB.	2 story sfr w/ attached garage	2013
New	Approved Basic 13-100872.	IRC 2009.	Plan # 2832-02AB.	2 story sfr w/ attached garage	2013
New	Approved basic 12-100077 BP	2009 IRC	Plan# 2601-02AB	2-story sfr w/attached garage	2013
New	Approved basic 10-109025 BP	2009 IRC	Plan# 2384-02AB	2-story sfr w/attached garage	2013
New	Approved basic 12-100408 BP	2009 IRC	Plan# 2808-02AB	2-story sfr w/attached garage	2013
New	Approved basic 12-105541 BP	2009 IRC	Plan#2512-02AB	2-story sfr w/attached garage	2013
New	Approved basic 12-105541 BP	2009 IRC	Plan#2512-02AB	2-story sfr w/attached garage	2013
New	Approved basic 12-100408 BP	2009 IRC	Plan# 2808-02AB	2-story sfr w/attached garage	2013
New	Approved basic 12-100077 BP	2009 IRC	Plan# 2601-02AB	2-story sfr w/attached garage	2013
New	Approved basic 12-100408 BP	2009 IRC	Plan# 2808-02AB	2-story sfr w/attached garage	2013
New	Approved basic 10-109025 BP	2009 IRC	Plan# 2384-02AB	2-story sfr w/attached garage	2013
New	Approved basic 12-100077 BP	2009 IRC	Plan# 2601-02AB	2-story sfr w/attached garage	2013
New	Approved basic 12-100077 BP	2009 IRC	Plan# 2601-02AB	2-story sfr w/attached garage	2013
New	Approved basic 10-109025 BP	2009 IRC	Plan# 2384-02AB	2-story sfr w/attached garage	2013
New	2-story sfr w/attached garage				2013

Accessory Dwelling Units

Index # - File Name: 1.0022 - Single Family Dwellings Data\_Snohomish County.pdf

New	Rambler style sfr w/attached garage				2013
New	2 story sfr w/ attached garage.				2013
New	Approved Basic 13-100884 BP	2009 IRC	Plan # 20-30.02M (.2) HENLEY.	2 story sfr w/ a	2013
New	Approved basic 13-102819 BP	2009 IRC	Plan# 15-30.02 D HENLEY	2-story sfr w/atta	2013
New	Approved basic 13-101828 BP	2009 IRC	Plan# 18-30.02 C HENLEY	2-story sfr w/	2013
New	Approved basic 13-101842 BP	2009 IRC	Plan# 29-30.06 A HENLEY	2-story sfr w/at	2013
New	Approved basic 13-101831 BP	2009 IRC	Plan# 20-30.02 F (.2) HENLEY	2-story sfr w/	2013
New	Approved basic 13-101828 BP	2009 IRC	Plan# 18-30.02 C HENLEY	2-story sfr w/	2013
New	Approved basic 13-101830 BP	2009 IRC	Plan# 18-30.02 M (.2) HENLEY	2-story sfr w/	2013
New	Approved basic 13-102514 BP	2009 IRC	Plan# 16-30.02 D HENLEY	2-story sfr w/at	2013
New	Approved basic 13-101831 BP	2009 IRC	Plan# 20-30.02 F (.2) HENLEY	2-story sfr w/	2013
New	Approved basic 13-101828 BP	2009 IRC	Plan# 18-30.02 C HENLEY	2-story sfr w/	2013
New	Approved basic 13-101846 BP	2009 IRC	Plan# 18-30.02 J HENLEY	2-story sfr w/at	2013
New	Approved basic 13-101841 BP	2009 IRC	Plan# 18-30.02 D HENLEY	2-story sfr w/at	2013
New	2 story sfr w/ attached garage.				2013
New	Approved basic 13-111321.	2012 IRC.	Plan # 33-30.02 F2.	2 story sfr w/ attached gara	2013
New	Approved basic 13-110883.	2012 IRC.	Plan # 32-30.02 V - Henley5.	2 story sfr w/ attached	2013
New	Approved Basic 13-100884 BP	2009 IRC	. Plan # 20-30.02M (.2) HENLEY.	2 story sfr w/	2013
New	Approved basic 13-101841 BP	2009 IRC	Plan# 18-30.02 D HENLEY	2-story sfr w/at	2013
New	Approved basic 13-112659.	2012 IRC.	Plan #34-30.02 H.	2 story sfr w/ attached	2013
New	Approved basic 10-109376 BP	2009 IRC	Plan# 2230-50-8	2-story sfr w/attached gar	2013
New	Approved basic 12-110055 BP	2009 IRC	Plan# 2683/2	2-story sfr w/attached }	2013
New	SFR - rambler, 3910 sqft with 1038 sf attached garage (2 bedroom/3 bath)				2013
New	Two-story SFR with bonus room over garage - 2009 IRC				2013
New	Approved basic 13-100149 BP	2009 IRC	Plan# 20-30.12 F	2-story sfr w/attached ga	2013
New	allowing until 7/9/15 to obtain final inspection and signed off 6/17/15 dm			2013 28 x 60 Skyline	2013
New	Approved basic 11-109973 BP	2009 IRC	Plan# Brooks-A	2-story sfr w/attached	2013
New	Approved basic 11-108137 BP	2009 IRC	Plan# Blake A	2-story sfr w/attached }	2013
New	Approved basic 12-104520 BP	2009 IRC	Plan# Brooks - B	2-story sfr w/attached ga	2013
New	2-story sfr w/attached garage				2013
New	2-story sfr w/attached garage				2013
New	Approved basic 12-107195 BP	2009 IRC	Plan# Blake B	2-story sfr w/attached gara	2013
New	Approved basic 12-109693 BP	2009 IRC	Plan# Brooks B3	2-story sfr w/attached ga	2013
New	Rambler style duplex w/attached garage				2013
New	Approved basic 14-101358 BP	2012 IRC	Plan# 2774	2-story sfr w/attache	2014
New	Two-story SFR with attached garage - 2012 IRC				2014
New	Two-story SFR with attached garage - 2012 IRC				2014
New	Two-story SFR with attached garage - 2012 IRC				2014
New	SFR, new rambler with attached garage and covered porch, 4 bedroom, 3 bath				2014
New	2 story SFR with attached garage				2014
New	Approved basic 14-108687 BP	2012 IRC	Plan# 3049 end load	2-story sfr w/att	2014
New	Approved basic 14-101356 BP	2012 IRC	Plan# 2313	Rambler styl sfr w/	2014
New	Approved basic 14-101358 BP	2012 IRC	Plan# 2774	2-story sfr w/attache	2014
New	Approved basic 14-110318 BP	2012 IRC	Plan#2131 Rambler	Rambler style	2014
New	SFR, two story with home with attached 4 car garage, unfinished (no drywall) storage above gar				2014
New	Approved basic 13-111972 BP	2012 IRC	Plan#2860-30-9	3 story sfr w/attached ga	2014
New	Approved basic 13-111972 BP	2012 IRC	Plan#2860-30-9	3 story sfr w/attached ga	2014

Accessory Dwelling Units

Index # - File Name: 1.0022 - Single Family Dwellings Data\_Snohomish County.pdf

New	Approved	basic 13-111972 BP	2012 IRC	Plan#2860-30-9	3 story sfr w/attached ga	2014
New	Approved	basic 13-111972 BP	2012 IRC	Plan#2860-30-9	3 story sfr w/attached ga	2014
New	Approved	basic 13-111972 BP	2012 IRC	Plan#2860-30-9	3 story sfr w/attached ga	2014
New	Approved	basic 13-111972 BP	2012 IRC	Plan#2860-30-9	3 story sfr w/attached ga	2014
New	Approved	basic 14-110110 BP	2012 IRC	Plan# 2535	3-storys sfr w/attached g	2014
New	Approved	basic 14-110110 BP	2012 IRC	Plan# 2535	3-storys sfr w/attached ga	2014
New	Approved	basic 13-111972 BP	2012 IRC	Plan#2860-30-9	3 story sfr w/attached ga	2014
New	Approved	basic 14-106449 BP	2012 IRC	Plan# 3400	2-story sfr w/attached garage	2014
New	Approved	basic 14-106449 BP	2012 IRC	Plan# 3400	2-story sfr w/attached garage	2014
New	2-story sfr w/finished daylighted basement w/attached garage					2014
New	Approved	basic 14-106449 BP	2012 IRC	Plan# 3400	2-story sfr w/attached garage	2014
New	Approved	basic 14-106449 BP	2012 IRC	Plan# 3400	2-story sfr w/attached garage	2014
New	Approved	basic 14-106449 BP	2012 IRC	Plan# 3400	2-story sfr w/attached garage	2014
New	Approved	basic 13-107236 BP	2009 IRC	Plan# 2457/2DB	Rambler style attached gar	2014
New	SFR, rambler style with attached 2 car garage, 3 bedroom 2 bath					2014
New	Approved	basic 12-110050 BP	2009 IRC	Plan# 2417/2	2-story sfr w/attached	2014
New	Approved	basic 12-110050 BP	2009 IRC	Plan# 2417/2	2-story sfr w/attached	2014
New	Approved	basic 12-110052 BP	2009 IRC	Plan# 2536/2	2-story sfr w/attach	2014
New	Approved	basic 12-110052 BP	2009 IRC	Plan# 2536/2	2-story sfr w/attach	2014
New	2570 sf rambler with attached garage - 2012 IRC					2014
New	2570 sf rambler with attached garage and 610 sf unheated storage - 2012 IRC					2014
New	2416 sf SFR with 1903 finished daylight basement and attached garage - 2012 IRC					2014
New	Two story SFR with daylight basement - 2012 IRC					2014
New	SFR, rambler with attached 3 car garage, 3 bedroom, plus den/office, 1.75 baths					2014
New	Two-story SFR with attached garage 2012 IRC					2014
New	1994 27ft x 69ft Marle Desert Manor					2014
New	SFR with Unfinished Basement(rough in plumbing)and Attached Garage. See 14-106005-LDA					2014
New	Approved	basic 13-115528 BP.	2012 IRC.	Plan # 2339.	2 story sfr w/ attached garage.	2014
New	Approved	basic 14-103337 BP.	2012 IRC.	Plan 2686.	2 story sfr w/ attached garag	2014
New	Approved	basic 13-112889 BP.	2012 IRC.	Plan # 2501-B.	2 story sfr w/ attached garage.	2014
New	Rambler with Attached Garage					2014
New	2 story sfr w/ attached garage.					2014
New	2 story sfr w. attached garage.					2014
New	2 story sfr w/ attached garage.					2014
New	Rambler style sfr w/attached garage					2014
New	Approved	basic 14-101018 BP	2012 IRC	Plan# Teton-B	2-story sfr w/attached	2014
New	Approved	basic 14-100516 BP	2012 IRC	Plan# Dayton-B	2-story sfr w/attached g	2014
New	Approved	basic 14-110820 BP	2012 IRC	Plan# Hazelwood B	2-story sfr w/attached	2014
New	Approved	basic 13-111590 BP	2012 IRC	Plan# Dayton-A	2-story sfr w/attached	2014
New	Approved	basic 14-110827 BP	2012 IRC	Plan# Selkirk B	2-story sfr w/attached ga	2014
New	Approved	basic 14-105305 BP	2012 IRC	Plan# Jefferson-A	2-story sfr w/attache	2014
New	Approved	basic 13-111590 BP	2012 IRC	Plan# Dayton-A	2-story sfr w/attached	2014
New	Approved	basic 13-114583 BP	2012 IRC	Plan# Kimball-A	2-story sfr w/attached g	2014
New	Approved	basic 13-111590 BP	2012 IRC	Plan# Dayton-A	2-story sfr w/attached	2014
New	Approved	basic 14-105305 BP	2012 IRC	Plan# Jefferson-A	2-story sfr w/attache	2014
New	Approved	basic 14-106795 BP	2012 IRC	Plan# Granite -A	2-story sfr w/attached g	2014
New	Approved	basic 14-110225 BP	2012 IRC	Plan# Granite B	2-story sfr w/attach	2014

Accessory Dwelling Units

Index # - File Name: 1.0022 - Single Family Dwellings Data\_Snohomish County.pdf

New	Approved	basic 14-100516 BP	2012 IRC	Plan# Dayton-B	2-story sfr w/attached g	2014
New	Approved	basic 13-111942.	2012 IRC.	Plan #3114-A.	2 story sfr w/ finished basement and ai	2014
New	Approved	basic 13-112895 BP.	2012 IRC.	Plan# 2845-B.	3 story sfr w/ attached garage.	2014
New	Approved	basic 13-111943.	2012 IRC.	Plan #3114-C.	3 story sfr w/ basement	2014
New	Approved	basic 13-112898 BP.	2012 IRC.	Plan # 2845-A.	2 story sfr w/ daylight basement a	2014
New	Approved	basic 13-111872.	2012 IRC.	Plan # 2873-C.	2 story sfr w/ attache	2014
New	Approved	basic 14-109191BP.	2012 IRC.	Plan # 3183-C.	2 story sfr w/ attache	2014
New	Approved	basic 13-111873BP	2012 IRC.	Plan#2137-A.	2 story sfr w/ attache	2014
New	Approved	basic 13-111872.	2012 IRC.	Plan # 2873-C.	2 story sfr w/ attache	2014
New	Approved	basic 13-111873BP	2012 IRC.	Plan#2137-A.	2 story sfr w/ attache	2014
New	Approved	basic 13-111869.	2012 IRC.	Plan # 2873-A.	2 story sfr w/ attached gara	2014
New	Approved	basic 13-111937BP	2012 IRC.	Plan #2311-B.	2 story sfr w/ attached garage.	2014
New	Approved	basic 13-111869.	2012 IRC.	Plan # 2873-A.	2 story sfr w/ attached gara	2014
New	Approved	basic 13-112888 BP.	2012 IRC.	Plan # 2501-C.	2 story sfr w/ attached garage.	2014
New	Approved	basic 13-111937BP	2012 IRC.	Plan #2311-B.	2 story sfr w/ attached garage.	2014
New	Approved	basic 13-112887.	2012 IRC.	Plan # 2501-A.	2 story sfr w/ attached g	2014
New	Approved	basic 13-111937BP	2012 IRC.	Plan #2311-B.	2 story sfr w/ attached garage.	2014
New	Approved	basic 13-111873BP	2012 IRC.	Plan#2137-A.	2 story sfr w/ attache	2014
New	Approved	basic 13-111937BP	2012 IRC.	Plan #2311-B.	2 story sfr w/ attached garage.	2014
New	Approved	basic 13-112888 BP.	2012 IRC.	Plan # 2501-C.	2 story sfr w/ attached garage.	2014
New	Approved	basic 13-111873BP	2012 IRC.	Plan#2137-A.	2 story sfr w/ attache	2014
New	Approved	basic 13-111937BP	2012 IRC.	Plan #2311-B.	2 story sfr w/ attached garage.	2014
New	Approved	basic 13-112887	2012 IRC.	Plan # 2501-A.	2 story sfr w/ attached ga	2014
New	Approved	basic 13-111937BP	2012 IRC.	Plan #2311-B.	2 story sfr w/ attached garage.	2014
New	Approved	basic 13-114842.	2012 IRC.	Plan # 2190-A.	2 story sfr w/ attache	2014
New	Approved	basic 13-114843 BP.	2012 IRC.	Plan 2190-B.	2 story sfr w/ attached gara	2014
New	Approved	basic 13-112888 BP.	2012 IRC.	Plan # 2501-C.	2 story sfr w/ attached garage.	2014
New	Approved	basic 13-111937BP	2012 IRC.	Plan #2311-B.	2 story sfr w/ attached garage.	2014
New	Approved	basic 13-111873BP	2012 IRC.	Plan#2137-A.	2 story sfr w/ attache	2014
New	Approved	basic 13-112888 BP.	2012 IRC.	Plan # 2501-C.	2 story sfr w/ attached garage.	2014
New	Approved	basic 13-111937BP	2012 IRC.	Plan #2311-B.	2 story sfr w/ attached garage.	2014
New	Approved	basic 13-112887.	2012 IRC.	Plan # 2501-A.	2 story sfr w/ attached g	2014
New	Approved	basic 13-113544 BP.	2012 IRC.	Plan #551 B.	2 story sfr w/ attached garage and di	2014
New	Approved	basic 13-113537 BP.	2012 IRC.	Plan # 515 BC.	2 story sfr w/attached garage and	2014
New	Approved	basic 13-113538 BP.	2012 IRC.	Plan # 546A.	2 story sfr w/ attached garage an	2014
New	Approved	basic 13-113541 BP.	2012 IRC.	Plan # 551 A.	2 story sfr w/ attached garage and	2014
New	Approved	basic 13-113537 BP.	2012 IRC.	Plan # 515 BC.	2 story sfr w/attached garage and	2014
New	Approved	basic 14-113886 BP	2012 IRC	Plan# 417 ABCD	2-story sfr w/attached gar	2014
New	Approved	basic 13-109708 BP	2012 IRC	Plan# 455 AB	2-story sfr w/attached gara	2014
New	Approved	basic 13-109291 BP	2012 IRC	Plan# 448 A	2-story sfr w/attached garage	2014
New	Approved	basic 14-105376 BP	2012IRC	Plan# 456 AB	2-story sfr w/attached g	2014
New	Approved	basic 14-113886 BP	2012 IRC	Plan# 417 ABCD	2-story sfr w/attached gar	2014
New	Approved	basic 14-105376 BP	2012IRC	Plan# 456 AB	2-story sfr w/attached g	2014
New	Approved	basic 13-110082 BP.	2012 IRC.	Plan # 451 AB.	2 story sfr w/ attached g	2014
New	Approved	basic 13-109294 BP	2012 IRC	Plan# 461 A	2-story sfr w/attached garag	2014
New	Approved	basic 13-109708 BP	2012 IRC	Plan# 455 AB	2-story sfr w/attached gara	2014
New	Approved	basic 13-109293 BP	2012 IRC	Plan#472 AB	2-story sfr w/attached garage	2014

Accessory Dwelling Units

Index # - File Name: 1.0022 - Single Family Dwellings Data\_Snohomish County.pdf

New	Approved	basic 13-109292 BP	2012 IRC	Plan# 448 B	2-story sfr w/attached garage	2014
New		2 story sfr w/ attached garage.				2014
New		2 story sfr w/ attached garage.				2014
New	Approved	Basic 13-111028 BP.	2012 IRC.	Plan # 3308.	2 story sfr w/ attached	2014
New	Approved	basic 13-111027 BP.	2012 IRC.	Plan 2992.	2 story sfr w/ attache	2014
New	Approved	basic 13-111033 BP.	2012 IRC.	Plan #3104.	2 story sfr w/ attache	2014
New		1895sq ft SFR with 1722 sq ft Unfinished Basement and Attached Garage				2014
New		Two-story SFR with attached garage - 2012 IRC				2014
New	Approved	basic 14-107416 BP	2012 IRC	Plan# Baker-A	2-story sfr w/attached garag	2014
New	Approved	basic 14-107682 BP	2012 IRC	Plan# Franklin-A	2-story sfr w/attached g	2014
New	Approved	basic 14-107416 BP	2012 IRC	Plan# Baker-A	2-story sfr w/attached gara	2014
New	Approved	basic 14-107682 BP	2012 IRC	Plan# Franklin-A	2-story sfr w/attached g	2014
New	Approved	basic 13-107228 BP	2012 IRC	Plan# Cascade-A	2-story sfr w/attached ga	2014
New	Approved	basic 14-107682 BP	2012 IRC	Plan# Franklin-A	2-story sfr w/attached }	2014
New	Approved	basic 13-107219 BP	2012 IRC	Plan# Cascade-B	2-story sfr w/attached garag	2014
New	Approved	basic 14-102195 BP	2012 IRC	Plan# Olympic-B	2-story sfr w/attached g	2014
New	Approved	basic 13-114756 BP	2012 IRC	Plan# Rainier-B	2-story sfr w/attached }	2014
New	Approved	basic 13-114583 BP	2012 IRC	Plan# Kimball-A	2-story sfr w/attached g	2014
New	Approved	basic 14-102194 BP	2012 IRC	Plan# Skagit-A	2-story sfr w/attached	2014
New	Approved	basic 13-107217 BP	2012 IRC	Plan# Franklin-B	2-story sfr w/attached garage	2014
New	Approved	basic 14-102195 BP	2012 IRC	Plan# Olympic-B	2-story sfr w/attached g	2014
New	Approved	basic 14-102194 BP	2012 IRC	Plan# Skagit-A	2-story sfr w/attached	2014
New	Approved	basic 13-114582 BP	2012 IRC	Plan# Rainier-A	2-story sfr w/attached g	2014
New	Approved	basic 14-101019 BP	2012 IRC	Plan# Barclay-A	3-story sfr w/attache	2014
New	Approved	basic 14-101021 BP	2012 IRC	Plan# Bryant-B	2-story sfr w/attache	2014
New	Approved	basic 14-102197 BP	2012 IRC	Plan# Shasta II-B	2-story sfr w/attached	2014
New	Approved	basic 14-101020 BP	2012 IRC	Plan# Barclay-B	3-story sfr w/attache	2014
New	Approved	basic 14-105305 BP	2012 IRC	Plan# Jefferson-A	2-story sfr w/attache	2014
New	Approved	basic 14-105305 BP	2012 IRC	Plan# Jefferson-A	2-story sfr w/attache	2014
New	Approved	basic 14-105305 BP	2012 IRC	Plan# Jefferson-A	2-story sfr w/attache	2014
New	Approved	basic 13-115391 BP	2012 IRC	Plan# 3230	2-story sfr w/attached	2014
New	Approved	basic 13-115386 BP	2012 IRC	Plan# 3398	2-story sfr w/attached garage	2014
New	Approved	basic 13-115386 BP	2012 IRC	Plan# 3398	2-story sfr w/attached garage	2014
New	Approved	basic 13-115392 BP	2012 IRC	Plan# 3252	2-story sfr w/attached gara	2014
New	Approved	basic 13-115386 BP	2012 IRC	Plan# 3398	2-story sfr w/attached garage	2014
New	Approved	basic 13-115392 BP	2012 IRC	Plan# 3252	2-story sfr w/attached gara	2014
New	Approved	basic 13-115386 BP	2012 IRC	Plan# 3398	2-story sfr w/attached garage	2014
New	Approved	basic 13-115391 BP	2012 IRC	Plan# 3230	2-story sfr w/attached	2014
New	Approved	basic 14-101084 BP	2012 IRC	Plan# 2804	2-story sfr w/attached	2014
New	Approved	basic 13-111033 BP.	2012 IRC.	Plan #3104.	2 story sfr w/ attache	2014
New		Residential building permit: Changing crawl space to a finished basement				2014
New		New 2 story SFR with attached garage. SEE: 13-113925-LDA				2014
New	Approved	basic 13-114094 BP	2012 IRC	Plan# 2200	2-story sfr w/attached	2014
New	Approved	basic 14-101084 BP	2012 IRC	Plan# 2804	2-story sfr w/attached	2014
New	Approved	basic 14-101076 BP	2012 IRC	Plan# 2550	2-story sfr w/attached }	2014
New	Approved	basic 14-101081 BP	2012 IRC	Plan# 2688	2-story sfr w/attached	2014
New	Approved	basic 14-101078 BP	2012 IRC	Plan# 2441	2-story sfr w/attached	2014

Accessory Dwelling Units

Index # - File Name: 1.0022 - Single Family Dwellings Data\_Snohomish County.pdf

New	Approved basic 14-101078 BP	2012 IRC	Plan# 2441	2-story sfr w/attached	2014
New	Approved basic 13-112490.	2012 IRC.	Plan # 2688.	2 story sfr w/ attached g	2014
New	Approved basic 13-112492.	2012 IRC.	Plan 2660.	2 story sfr w/ attached garage.	2014
New	Approved basic 13-112492.	2012 IRC.	Plan 2660.	2 story sfr w/ attached garage.	2014
New	Approved basic 13-112490.	2012 IRC.	Plan # 2688.	2 story sfr w/ attached g	2014
New	Approved basic 14-101076 BP	2012 IRC	Plan# 2550	2-story sfr w/attached	2014
New	Approved basic 14-101081 BP	2012 IRC	Plan# 2688	2-story sfr w/attached	2014
New	Approved basic 13-112491.	IRC 2012.	Plan #2660.	2 story sfr w/ attached gara	2014
New	Approved basic 13-112491.	IRC 2012.	Plan #2660.	2 story sfr w/ attached gara	2014
New	Approved basic 13-111033 BP.	2012 IRC.	Plan #3104.	2 story sfr w/ attache	2014
New	Rambler style sfr w/attached garage				2014
New	Rambler style sfr w/attached garage				2014
New	2-story sfr w/attached garage				2014
New	2-story sfr w/attached garage				2014
New	Approved Basic 13-111028 BP.	2012 IRC.	Plan # 3308.	2 story sfr w/ attached	2014
New	Approved basic 13-111033 BP.	2012 IRC.	Plan #3104.	2 story sfr w/ attache	2014
New	Approved basic 13-111033 BP.	2012 IRC.	Plan #3104.	2 story sfr w/ attache	2014
New	Approved basic 13-110977 BP	2012 IRC	Plan: 2160	Two-story SFR with attached gara	2014
New	Approved basic 13-110032 BP.	2012 IRC.	Plan # 471 AB.	2 story sfr w/ attached garage.	2014
New	Approved basic 13-110033 BP.	2012 IRC.	Plan #472 AB.	2 story sfr w/ attached garage.	2014
New	Approved basic 13-106890 BP	2012 IRC	Plan# 467 A	2-story sfr w/attached garage	2014
New	Approved basic 13-114703 BP	2012 IRC	Plan# 3210	2-story sfr w/attached garag	2014
New	Approved basic 13-114703 BP	2012 IRC	Plan# 3210	2-story sfr w/attached garag	2014
New	Approved basic 14-103100 BP	2012 IRC	Plan# 2573	2-story sfr w/attached g	2014
New	Approved basic 14-103100 BP	2012 IRC	Plan# 2573	2-story sfr w/attached g	2014
New	Two-story SFR - 2012 IRC				2014
New	Approved basic 13-109608 BP	2012 IRC	Plan# 3727-B	2-story sfr w/attached gar	2014
New	2-story sfr w/attached garage				2014
New	2-story sfr w/attached garage				2014
New	2-story sfr w/attached garage				2014
New	2-story sfr w/attached garage				2014
New	2-story sfr w/attached garage				2014
New	2-story sfr w/attached garage				2014
New	2-story sfr w/attached garage				2014
New	2-story sfr w/attached garage				2014
New	2-story sfr w/attached garage				2014
New	2-story sfr w/attached garage				2014
New	2-story sfr w/attached garage				2014
New	2-story sfr w/attached garage				2014
New	2-story sfr w/attached garage				2014
New	Approved basic 13-111070 BP	2012 IRC	Plan# B729-B	2-story sfr w/attached	2014
New	Approved basic 13-111068 BP	2012 IRC	Plan# B724-B	2-story sfr w/attache	2014
New	Approved basic 13-111761 BP	2012 IRC	Plan# B722-B	2-story sfr w/attached g	2014
New	Approved basic 13-111069 BP.	2012 IRC	Plan# B729-A	2-story sfr w/attache	2014
New	Approved basic 13-111760 BP	2012 IRC	Plan# B722-A	2-story sfr w/attached g	2014
New	Approved basic 13-111067 BP	2012 IRC	Plan# B724-A	2-story sfr w/attached gai	2014
New	Approved basic 13-111069 BP.	2012 IRC	Plan# B729-A	2-story sfr w/attache	2014
New	Approved basic 13-111053 BP	2012 IRC	Plan# B720-A	2-story sfr w/attached g	2014



Accessory Dwelling Units

Index # - File Name: 1.0022 - Single Family Dwellings Data\_Snohomish County.pdf

New	Approved	basic 13-109473 BP	2012 IRC	Plan# 4710-A	2-story sfr w/attached garag	2014
New	Approved	basic 13-109607 BP	2012 IRC	Plan# 3727-A	2-story sfr w/attached gar	2014
New	Approved	basic 13-108847 BP.	2012 IRC.	Plan # 3829-A.	2 story sfr w/ attache	2014
New	Approved	basic 13-108682 BP.	2012 IRC.	Plan # 3724-B.	2 story sfr w/ attache	2014
New	Approved	basic 13-108686.	2012 IRC.	Plan # 3729 - A.	2 story sfr w/ attache	2014
New	Approved	Basic 13-108849 BP.	2012 IRC.	Plan # 3829-B.	2 story sfr w/ attache	2014
New	Approved	basic 13-108687 BP.	2012 IRC.	Plan # 3729-B.	2 story sfr w/ attache	2014
New	Approved	basic 13-112362 BP	2012 IRC	Plan# Juanita	2-story sfr w/attached gar	2014
New	Approved	basic 13-112362 BP	2012 IRC	Plan# Juanita	2-story sfr w/attached gar	2014
New	Approved	Basic 14-100853 BP	2012 IRC	Plan # BRENTWOOD	Two story single family wit	2014
New	Approved	Basic 14-100853 BP	2012 IRC	Plan # BRENTWOOD	Two story single family wit	2014
New	Approved	basic 13-109990 BP	2012 IRC	Plan# Andrews	2-story sfr w/attached ga	2014
New	Approved	Basic 14-100853 BP	2012 IRC	Plan # BRENTWOOD	Two story single family wit	2014
New	Approved	basic 13-113235 BP.	2012 IRC.	Plan #31-30.02 V4 - Henley10.	2 story sfr w/ atti	2014
New	Approved	basic 14-102307 BP	2012 IRC	Plan# 35-30.02 H - Henley18	2-story sfr v	2014
New	Approved	basic 13-112656 BP.	2012 IRC.	Plan #34-30.02.	2 story sfr w/ attached garage.	2014
New	Approved	basic 14-106988 BP	2012 IRC	Plan# 35-30.02 T4 - Henley29	2-story sfr w/	2014
New	Approved	basic 14-105203 BP	2012 IRC	Plan# 33-30.12 A4 - Henley25	2-story sfr	2014
New	Approved	basic 14-105819 BP	2012 IRC	Plan# 32-30.12 J - Henley26	2-story sfr w	2014
New	Approved	basic 13-111068 BP	2012 IRC	Plan# B724-B	2-story sfr w/attache	2014
New	Approved	basic 13-111069 BP.	2012 IRC	Plan# B729-A	2-story sfr w/attache	2014
New	Approved	basic 13-111760 BP	2012 IRC	Plan# B722-A	2-story sfr w/attached g	2014
New	Approved	basic 13-111073 BP	2012 IRC	Plan# B720-B	2-story sfr w/attached	2014
New	Approved	basic 13-111053 BP	2012 IRC	Plan# B720-A	2-story sfr w/attached g	2014
New	Approved	basic 13-111067 BP	2012 IRC	Plan# B724-A	2-story sfr w/attached ga	2014
New	Approved	basic 13-108687 BP.	2012 IRC.	Plan # 3729-B.	2 story sfr w/ attache	2014
New	Approved	basic 13-10684 BP.	2012 IRC.	Plan # 3726-B.	2 story sfr w/ attached garag	2014
New		2-story sfr w/attached garage				2014
New	Approved	basic 13-109608 BP	2012 IRC	Plan# 3727-B	2-story sfr w/attached gar	2014
New	Approved	Basic 13-108683 BP.	2012 IRC.	Plan # 3726-A.	2 story sfr w/ attache	2014
New	Approved	basic 13-109473 BP	2012 IRC	Plan# 4710-A	2-story sfr w/attached garag	2014
New	Approved	Basic 13-108849 BP.	2012 IRC.	Plan # 3829-B.	2 story sfr w/ attache	2014
New	Approved	basic 13-108689 BP	2012 IRC	Plan#3733-A	2-story sfr w/attached gara	2014
New	Approved	basic 13-108686.	2012 IRC.	Plan # 3729 - A.	2 story sfr w/ attache	2014
New	Approved	basic 13-109607 BP	2012 IRC	Plan# 3727-A	2-story sfr w/attached gar	2014
New	Approved	basic 13-108689 BP	2012 IRC	Plan#3733-A	2-story sfr w/attached gara	2014
New	Approved	Basic 13-108683 BP.	2012 IRC.	Plan # 3726-A.	2 story sfr w/ attache	2014
New	Approved	basic 13-109473 BP	2012 IRC	Plan# 4710-A	2-story sfr w/attached garag	2014
New		2-story sfr w/attached garage				2014
New		2-story sfr w/attached garage				2014
New		2-story sfr w/attached dropped garage				2014
New		2-story sfr w/attached garage				2014
New		2-story sfr w/attached dropped garage				2014
New		2-story sfr w/attached garage				2014
New		2-story sfr w/attached garage				2014
New		2-story sfr w/attached drop down garage				2014
New		2-story sfr w/attached drop down garage				2014

Accessory Dwelling Units

Index # - File Name: 1.0022 - Single Family Dwellings Data\_Snohomish County.pdf

New	Approved	basic 13-108682 BP.	2012 IRC.	Plan # 3724-B.	2 story sfr w/ attache	2014
New	Approved	basic 13-108686.	2012 IRC.	Plan # 3729 - A.	2 story sfr w/ attache	2014
New	Approved	basic 13-109607 BP	2012 IRC	Plan# 3727-A	2-story sfr w/attached gar	2014
New	Approved	basic 13-10684 BP.	2012 IRC.	Plan # 3726-B.	2 story sfr w/ attached gara	2014
New	Approved	Basic 13-108849 BP.	2012 IRC.	Plan # 3829-B.	2 story sfr w/ attache	2014
New	Approved	basic 13-108689 BP	2012 IRC	Plan#3733-A	2-story sfr w/attached gara	2014
New	Approved	basic 13-108687 BP.	2012 IRC.	Plan # 3729-B.	2 story sfr w/ attache	2014
New	Approved	basic 13-108847 BP.	2012 IRC.	Plan # 3829-A.	2 story sfr w/ attache	2014
New	Approved	basic 13-108690 BP	2012 IRC	Plan# 3733-B	2-story sfr w/attached gara	2014
New	Approved	basic 13-109608 BP	2012 IRC	Plan# 3727-B	2-story sfr w/attached gar	2014
New	Approved	Basic 13-108683 BP.	2012 IRC.	Plan # 3726-A.	2 story sfr w/ attache	2014
New	Approved	basic 13-112688 BP	2012 IRC	Plan# 4702-B	2-story sfr w/attached gara	2014
New		2-story sfr w/attached dropped garage				2014
New	Approved	basic 13-111873BP	2012 IRC.	Plan#2137-A.	2 story sfr w/ attache	2014
New	Approved	basic 13-112889 BP.	2012 IRC.	Plan # 2501-B.	2 story sfr w/ attached garage.	2014
New	Approved	basic 13-111937BP	2012 IRC.	Plan #2311-B.	2 story sfr w/ attached garage.	2014
New	Approved	basic 13-112887.	2012 IRC.	Plan # 2501-A.	2 story sfr w/ attached g	2014
New	Approved	basic 13-111873BP	2012 IRC.	Plan#2137-A.	2 story sfr w/ attache	2014
New	Approved	basic 13-111937BP	2012 IRC.	Plan #2311-B.	2 story sfr w/ attached garage.	2014
New	Approved	basic 13-111943.	2012 IRC.	Plan #3114-C.	3 story sfr w/ basement	2014
New	Approved	basic 13-112895 BP.	2012 IRC.	Plan# 2845-B.	3 story sfr w/ attached garage.	2014
New	Approved	basic 13-111942.	2012 IRC.	Plan #3114-A.	3 story sfr w/ finished basement and at	2014
New	Approved	basic 13-111872.	2012 IRC.	Plan # 2873-C.	2 story sfr w/ attache	2014
New	Approved	basic 14-105508 BP	2012 IRC	Plan# Jupiter 2005	Rambler sfr w/att	2014
New	Approved	basic 13-114094 BP	2012 IRC	Plan# 2200	2-story sfr w/attached	2014
New	Approved	basic 14-106849 BP	2012 IRC	Plan# 2254	2-story sfr w/attached gar	2014
New	Approved	basic 14-106849 BP	2012 IRC	Plan# 2254	2-story sfr w/attached gara	2014
New	Approved	basic 14-105508 BP	2012 IRC	Plan# Jupiter 2005	Rambler sfr w/att	2014
New	Approved	basic 13-114094 BP	2012 IRC	Plan# 2200	2-story sfr w/attached	2014
New	Approved	basic 14-105506 BP	2012 IRC	Plan# Julia Grande	2-story sfr w/attache	2014
New	Approved	basic 14-112963 BP	2012 IRC	Plan# 1704	Rambler style w/dayligh	2014
New	Approved	basic 14-106849 BP	2012 IRC	Plan# 2254	2-story sfr w/attached gar	2014
New	Approved	basic 13-115906 BP	2012 IRC	Plan# 33-30.02 F - Henely14	2-story sfr v	2014
New	Approved	basic 13-107227 BP	2012 IRC	Plan# Chelan II-A	2-story sfr w/attached gara	2014
New	Approved	basic 13-110833 BP	2012 IRC	Plan# Blakely B	2-story sfr w/attache	2014
New	Approved	basic 14-105306 BP	2012 IRC	Plan# Mason-B	2-story sfr w/attached ga	2014
New	Approved	basic 13-107227 BP	2012 IRC	Plan# Chelan II-A	2-story sfr w/attached gara	2014
New	Approved	basic 13-107219 BP	2012 IRC	Plan# Cascade-B	2-story sfr w/attached garag	2014
New	Approved	basic 13-107219 BP	2012 IRC	Plan# Cascade-B	2-story sfr w/attached garag	2014
New	Approved	basic 14-105306 BP	2012 IRC	Plan# Mason-B	2-story sfr w/attached g	2014
New	Approved	basic 13-107222 BP	2012 IRC	Plan# Baker-B	2-story sfr w/attached garag	2014
New	Approved	basic 13-107228 BP	2012 IRC	Plan# Cascade-A	2-story sfr w/attached ga	2014
New	Approved	basic 13-111878	2012 IRC.	Plan#3162-B.	2 story sfr w/ attached g	2014
New	Approved	basic 13-112888 BP.	2012 IRC.	Plan # 2501-C.	2 story sfr w/ attached garage.	2014
New	Approved	basic 14-109189 BP.	2012 IRC.	Plan # 3181-A.	2 story sfr w/ attache	2014
New	Approved	basic 13-111869.	2012 IRC.	Plan # 2873-A.	2 story sfr w/ attached gara	2014
New	Approved	basic 14-109192 BP.	2012 IRC.	Plan # 3183-B.	2 story sfr w/ attache	2014

Accessory Dwelling Units

Index # - File Name: 1.0022 - Single Family Dwellings Data\_Snohomish County.pdf

New	Approved basic 13-111872.	2012 IRC.	Plan # 2873-C.	2 story sfr w/ attached	2014
New	Approved basic 13-112887.	2012 IRC.	Plan # 2501-A.	2 story sfr w/ attached g	2014
New	Approved basic 13-111941.	2012 IRC.	Plan #2573-B.	2 story sfr w/ attached garage.	2014
New	Approved basic 13-112888 BP.	2012 IRC.	Plan # 2501-C.	2 story sfr w/ attached garage.	2014
New	Approved basic 13-111939.	2012 IRC.	Plan #2573-A.	2 story sfr w/ attached	2014
New	Approved basic 13-112887.	2012 IRC.	Plan # 2501-A.	2 story sfr w/ attached g	2014
New	Approved Basic 13-111940.	2012 IRC.	Plan #2573-C.	2 story sfr w/ attached g	2014
New	Approved basic 13-112888 BP.	2012 IRC.	Plan # 2501-C.	2 story sfr w/ attached garage.	2014
New	Approved basic 13-111872.	2012 IRC.	Plan # 2873-C.	2 story sfr w/ attached	2014
New	Approved basic 13-112889 BP.	2012 IRC.	Plan # 2501-B.	2 story sfr w/ attached garage.	2014
New	Approved basic 13-111939.	2012 IRC.	Plan #2573-A.	2 story sfr w/ attached	2014
New	Approved Basic 13-111940.	2012 IRC.	Plan #2573-C.	2 story sfr w/ attached g	2014
New	Apvd basic 13-111880.	2012 IRC.	Plan# 3162-A.	2 story sfr w/ attached gar	2014
New	Approved basic 13-111939.	2012 IRC.	Plan #2573-A.	2 story sfr w/ attached	2014
New	Approved basic 14-100515 BP	2012 IRC	Plan# Amherst-B	3-story sfr w/attach	2014
New	Approved basic 13-110012 BP	2012 IRC	Plan# 2818 B	2-story sfr w/attached gar	2014
New	Approved basic 13-111196 BP	2012 IRC	Plan# 3097 B	2-story sfr w/attached ga	2014
New	Approved basic 13-111194 BP	2012 IRC	Plan 3179 B	2-story sfr w/attached garag	2014
New	Approved basic 13-111199 BP	2012 IRC	Plan# 3069 A	2-story sfr w/attached gar	2014
New	Approved basic 13-110011 BP	2012 IRC	Plan# 3097	2-story sfr w/attached g	2014
New	Approved basic 13-111198 BP	2012 IRC	Plan# 3069 B	2-story sfr w/attached gar	2014
New	Two-story single family home with attached garage - 2012 IRC				2014
New	2570 sf rambler with attached garage - 2012 IRC				2014
New	Rambler style sfr w/daylight basement and attached garage				2014
New	2155sf Rambler with 840sf Attached Garage				2014
New	Manufactured Home, 2015, triple wide, Skyline Westridge, 42 x 70				2014
New	New SFR with garage/shop on 1st floor. SEE: 14-107524-LDA				2014
New	2-story sfr w/attached garage and finished baylighted basement				2014
New	Approved basic 13-111068 BP	2012 IRC	Plan# B724-B	2-story sfr w/attache	2014
New	2- story sfr w/daylight basement & attached garage				2014
New	Approved basic 13-108682 BP.	2012 IRC.	Plan # 3724-B.	2 story sfr w/ attache	2014
New	Approved basic 13-108847 BP.	2012 IRC.	Plan # 3829-A.	2 story sfr w/ attache	2014
New	Approved basic 13-108690 BP	2012 IRC	Plan# 3733-B	2-story sfr w/attached gara	2014
New	Approved basic 13-112687 BP	2012 IRC	Plan# 4702-A	2-story sfr w/attached ga	2014
New	Approved basic 13-112689 BP	2012 IRC	Plan# 4703-A	2-story sfr w/attached gara	2014
New	Approved basic 13-112688 BP	2012 IRC	Plan# 4702-B	2-story sfr w/attached gara	2014
New	Approved Basic 13-108849 BP.	2012 IRC.	Plan # 3829-B.	2 story sfr w/ attache	2014
New	Approved basic 13-108686.	2012 IRC.	Plan # 3729 - A.	2 story sfr w/ attache	2014
New	Approved basic 13-108682 BP.	2012 IRC.	Plan # 3724-B.	2 story sfr w/ attache	2014
New	Approved basic 13-108847 BP.	2012 IRC.	Plan # 3829-A.	2 story sfr w/ attache	2014
New	Approved basic 13-108687 BP.	2012 IRC.	Plan # 3729-B.	2 story sfr w/ attache	2014
New	Approved basic 13-108682 BP.	2012 IRC.	Plan # 3724-B.	2 story sfr w/ attache	2014
New	Approved basic 13-108686.	2012 IRC.	Plan # 3729 - A.	2 story sfr w/ attache	2014
New	Approved basic 13-108681 BP.	2012 IRC.	Plan # 3724 A.	2 story sfr w/ attache	2014
New	Approved basic 13-112687 BP	2012 IRC	Plan# 4702-A	2-story sfr w/attached ga	2014
New	Approved 13-112690 BP	2012 IRC	Plan# 4703-B	2-story sfr w/attached garage	2014
New	Approved basic 13-112688 BP	2012 IRC	Plan# 4702-B	2-story sfr w/attached gara	2014

Accessory Dwelling Units

Index # - File Name: 1.0022 - Single Family Dwellings Data\_Snohomish County.pdf

New	Approved	basic 14-108297 BP	2012 IRC	Plan# 23-40.02 H2 - Henley32	2-story sfr	2014	
New	Approved	basic 14-108555 BP	2012 IRC	Plan# 23-40.03 J4 - Henley32	2-story	2014	
New	SFR:	rambler style with attached 2 car garage and covered porch					2014
New	SFR,	rambler style with attached 2 car garage, 4 bedroom 2.5 bath					2014
New	Two-story SFR with attached garage - 2012 IRC						2014
New	Approved	basic 13-108689 BP	2012 IRC	Plan#3733-A	2-story sfr w/attached gara	2014	
New	Approved	basic 13-108682 BP.	2012 IRC.	Plan # 3724-B.	2 story sfr w/ attache	2014	
New	Approved	basic 13-108686.	2012 IRC.	Plan # 3729 - A.	2 story sfr w/ attache	2014	
New	Approved	basic 13-111068 BP	2012 IRC	Plan# B724-B	2-story sfr w/attache	2014	
New	Approved	basic 13-111760 BP	2012 IRC	Plan# B722-A	2-story sfr w/attached g	2014	
New	Approved	basic 13-108690 BP	2012 IRC	Plan# 3733-B	2-story sfr w/attached gara	2014	
New	Approved	basic 13-108686.	2012 IRC.	Plan # 3729 - A.	2 story sfr w/ attache	2014	
New	Approved	basic 13-108687 BP.	2012 IRC.	Plan # 3729-B.	2 story sfr w/ attache	2014	
New	Approved	basic 13-108682 BP.	2012 IRC.	Plan # 3724-B.	2 story sfr w/ attache	2014	
New	Duplex, rambler style with attached garage						2014
New	Approved	basic 13-111760 BP	2012 IRC	Plan# B722-A	2-story sfr w/attached g	2014	
New	Approved	Basic 13-108747 BP.	2012 IRC.	Plan# 3728-A.	2 Story sfr w/ attached	2014	
New	Approved	basic 14-107536 BP	2012 IRC	Plan# 2720	2-story sfr w/attached gara	2014	
New	Approved	basic 14-102087 BP	2012 IRC	Plan# 3313	2-story sfr w/attached gara	2014	
New	Approved	basic 14-102335 BP	2012 IRC	Plan# 3112	2-story sfr w/attached garage	2014	
New	Approved	basic 14-102336 BP	2012 IRC	Plan# 3165	2-story sfr w/attached g	2014	
New	Approved	basic 14-102087 BP	2012 IRC	Plan# 3313	2-story sfr w/attached gara	2014	
New	Approved	basic 14-102337 BP	2012 IRC	Plan# 2728	2-story sfr w/attached g	2014	
New	Approved	basic 14-102336 BP	2012 IRC	Plan# 3165	2-story sfr w/attached g	2014	
New	Approved	basic 14-102087 BP	2012 IRC	Plan# 3313	2-story sfr w/attached gara	2014	
New	Approved	basic 14-102336 BP	2012 IRC	Plan# 3165	2-story sfr w/attached g	2014	
New	Approved	basic 14-102337 BP	2012 IRC	Plan# 2728	2-story sfr w/attached g	2014	
New	Approved	basic 14-107536 BP	2012 IRC	Plan# 2720	2-story sfr w/attached gara	2014	
New	Approved	basic 14-102087 BP	2012 IRC	Plan# 3313	2-story sfr w/attached gara	2014	
New	Approved	basic 14-102337 BP	2012 IRC	Plan# 2728	2-story sfr w/attached g	2014	
New	Approved	basic 14-102335 BP	2012 IRC	Plan# 3112	2-story sfr w/attached garage	2014	
New	Approved	basic 14-107536 BP	2012 IRC	Plan# 2720	2-story sfr w/attached gara	2014	
New	Approved	basic 14-102335 BP	2012 IRC	Plan# 3112	2-story sfr w/attached garage	2014	
New	2-story sfr w/attached garage						2014
New	SFR, rambler style home with attached 2 car garage, 3 bedrooms and 2 baths						2014
New	Approved	basic 14-103708 BP	2012 IRC	Plan# Smith	2-story sfr w/attache	2014	
New	Approved	Basic 14-105939BP	Two-story SFR with attached garage - 2012 IRC		Plan 2073	2014	
New	New 2- story SFR with attached garage						2014
New	Three Story SFR with Attached Garage						2014
New	Approved	basic 14-101013 BP	2012 IRC	Plan# 4020	2-story sfr w/attached g	2014	
New	Two Story SFR with Attached Garage						2014
New	Approved	basic 14-103471 BP	2012 IRC	Plan# 6811	2-story sfr w/attached garag	2014	
New	SFR: 2 story home, 3 bedrooms 2.5 bath..***To be issued after or simultaneously w/ LDA permi						2014
New	New SFR rambler w/ attached garage. See 14-108108 -LDA						2014
New	New SFR rambler w/ attached garage. See 14-109542 - LDA						2014
New	DEMO OLD GARAGE and build new	Approved basic 13-112612 BP	2012 IRC	Plan# 3:		2014	
New	Rambler style sfr w/attached garage						2014

Accessory Dwelling Units

Index # - File Name: 1.0022 - Single Family Dwellings Data\_Snohomish County.pdf

New	Approved basic 13-112363 BP	2012 IRC	Plan# Ramblewood	Rambler sty	2014
New	2-story sfr w/attached garage				2014
New	Approved basic 14-100845 BP	2012IRC	Plan Number Hillcrest	Two story single family with	2014
New	Approved basic 13-112363 BP	2012 IRC	Plan# Ramblewood	Rambler style sfr w/attached	2014
New	New 2- story SFR with attached garage				2014
New	New 2 story SFR with attached garage				2014
New	Approved basic 13-112361 BP	2012 IRC	Plan# West Point	2-story sfr w/	2014
New	Approved basic 14-100845 BP	2012IRC	Plan Number Hillcrest	Two storey single family wi	2014
New	Approved basic 14-108165 BP	2012 IRC	Plan# Pennington	Rambler style sf	2014
New	Approved Basic 14-100853 BP	2012 IRC	Plan # BRENTWOOD	Two story single family wit	2014
New	Approved basic 13-112363 BP	2012 IRC	Plan# Ramblewood	Rambler style sfr w/attache	2014
New	SFR, new two story, 2 bedroom home with unfinished basement, 2 car garage				2014
New	Approved basic 13-108751 BP.	2012 IRC.	Plan # 3706 - B.	2 story sfr w/ attached	2014
New	Approved basic 13-103527 BP	2009 IRC	Plan# 4035A	2-story sfr w/attached gar	2014
New	Approved basic 13-103525 BP	2009 IRC	Plan# 4028B	2-story sfr w/attached ga	2014
New	Approved basic 13-103527 BP	2009 IRC	Plan# 4035A	2-story sfr w/attached gar	2014
New	Approved basic 13-105071.	2009 IRC.	Plan #4023B.	2 story sfr w/ attached garage. Tabl	2014
New	Approved basic 13-103528 BP	2009 IRC	Plan# 4035B	2-story sfr w/attached gar	2014
New	Approved basic 13-103524 BP	2009 IRC	Plan# 4028A	2-story sfr w/attached ga	2014
New	Approved basic plan 13-103529 BP	2009 IRC	Plan#4035C	2-story sfr w/attached	2014
New	Approved basic 13-103527 BP	2009 IRC	Plan# 4035A	2-story sfr w/attached gar	2014
New	Approved basic 13-103526 BP	2009 IRC	Plan# 4028C	2-story sfr w/attached garage	2014
New	Approved basic 14-101010 BP	2012 IRC	Plan# 4035C	2-story sfr w/attached ga	2014
New	Approved basic 14-101005 BP	2012 IRC	Plan# 4028A	2-story sfr w/attached ga	2014
New	Approved basic 14-101008 BP	2012 IRC	Plan# 4035A	2-story sfr w/attached ga	2014
New	Approved basic 14-101010 BP	2012 IRC	Plan# 4035C	2-story sfr w/attached ga	2014
New	Approved basic 14-101007 BP	2012 IRC	Plan# 4028C	2-story sfr w/attached	2014
New	Approved basic 14-101009 BP	2012 IRC	Plan# 4035B	2-story sfr w/attached g	2014
New	Approved basic 14-101004 BP	2012 IRC	Plan# 3019C	2-story sfr w/attached gara	2014
New	Approved basic 14-101000 BP	2012 IRC	Plan# 3014C	2-story sfr w/attached ga	2014
New	Approved basic 14-101003 BP	2012 IRC	Plan# 3019A	2-story sfr w/attached ga	2014
New	Approved basic 14-101004 BP	2012 IRC	Plan# 3019C	2-story sfr w/attached gara	2014
New	Approved basic 14-101000 BP	2012 IRC	Plan# 3014C	2-story sfr w/attached ga	2014
New	Approved basic 14-101004 BP	2012 IRC	Plan# 3019C	2-story sfr w/attached gara	2014
New	Approved basic 14-100999 BP	2012 IRC	Plan# 3014B	2-story sfr w/attached ga	2014
New	Approved basic 14-101003 BP	2012 IRC	Plan# 3019A	2-story sfr w/attached ga	2014
New	Approved basic 14-101009 BP	2012 IRC	Plan# 4035B	2-story sfr w/attached g	2014
New	Approved basic 14-101005 BP	2012 IRC	Plan# 4028A	2-story sfr w/attached ga	2014
New	Approved basic 14-101010 BP	2012 IRC	Plan# 4035C	2-story sfr w/attached ga	2014
New	Approved basic 14-101008 BP	2012 IRC	Plan# 4035A	2-story sfr w/attached ga	2014
New	Approved basic 14-101006 BP	2012 IRC	Plan# 4028B	2-story sfr w/attached gara	2014
New	Approved basic 14-101010 BP	2012 IRC	Plan# 4035C	2-story sfr w/attached ga	2014
New	Approved basic 14-101008 BP	2012 IRC	Plan# 4035A	2-story sfr w/attached ga	2014
New	Approved basic 14-101005 BP	2012 IRC	Plan# 4028A	2-story sfr w/attached ga	2014
New	Approved basic 14-101009 BP	2012 IRC	Plan# 4035B	2-story sfr w/attached g	2014
New	Approved basic 14-101000 BP	2012 IRC	Plan# 3014C	2-story sfr w/attached ga	2014
New	Approved basic 14-101004 BP	2012 IRC	Plan# 3019C	2-story sfr w/attached gara	2014

Accessory Dwelling Units

Index # - File Name: 1.0022 - Single Family Dwellings Data\_Snohomish County.pdf

New	Approved	basic 14-101003 BP	2012 IRC	Plan# 3019A	2-story sfr w/attached ga	2014
New	Approved	Basic 13-102429.	2009 IRC.	Plan # 3014B.	2 story SFR w/ attached g	2014
New	Approved	Basic # 13-102414.	IRC 2009.	Plan # 3013A.	2 story SFR w/ attached garage.	2014
New	Approved	Basic 13-102431.	2009 IRC.	Plan # 3019C.	2 story sfr w/ attache	2014
New	Approved	Basic 13-102426.	IRC 2009.	Plan # 3014C.	2 story sfr w/ attached gara	2014
New	Approved	Basic 13-102430.	2009 IRC.	Plan # 3019A.	2 story sfr w/ attached gara	2014
New	Approved	basic 13-108746 BP.	2012 IRC.	Plan # 3728-B.	2 story sfr w/ attached garage.	2014
New	Approved	basic 13-108692 BP	2012 IRC	Plan# 3904-A	2-story sfr w/attached garağ	2014
New	Approved	basic 13-108686.	2012 IRC.	Plan # 3729 - A.	2 story sfr w/ attache	2014
New	Approved	basic 13-108751 BP.	2012 IRC.	Plan # 3706 - B.	2 story sfr w/ attached	2014
New	Approved	basic 13-108693 BP	2012 IRC	Plan# 3904-B	2-story sfr w/attached garag	2014
New	Approved	Basic 13-108748 BP.	2012 IRC.	Plan # 3705-B.	2 story sfr w/ attached garage.	2014
New	Approved	Basic 13-108752 BP.	2012 IRC.	Plan # 3706 - A.	2 story sfr w/ attached ga	2014
New	Approved	Basic 13-108750 BP.	2012 IRC.	Plan # 3705-A.	2 story sfr w/ attached	2014
New	Approved	Basic 13-102429.	2009 IRC.	Plan # 3014B.	2 story SFR w/ attached g	2014
New	Approved	Basic 13-102419.	IRC 2009.	Plan # 3013C.	2 story SFR w/ attached gar	2014
New	Approved	Basic 13-102426.	IRC 2009.	Plan # 3014C.	2 story sfr w/ attached gara	2014
New	Approved	Basic 13-102431.	2009 IRC.	Plan # 3019C.	2 story sfr w/ attache	2014
New	Approved	basic 14-101000 BP	2012 IRC	Plan# 3014C	2-story sfr w/attached ga	2014
New	Approved	basic 14-100999 BP	2012 IRC	Plan# 3014B	2-story sfr w/attached ga	2014
New	Approved	basic 14-101003 BP	2012 IRC	Plan# 3019A	2-story sfr w/attached ga	2014
New	Approved	Basic 13-102430.	2009 IRC.	Plan # 3019A.	2 story sfr w/ attached gara	2014
New	Approved	Basic 13-102429.	2009 IRC.	Plan # 3014B.	2 story SFR w/ attached g	2014
New	Approved	Basic 13-102419.	IRC 2009.	Plan # 3013C.	2 story SFR w/ attached gar	2014
New	Approved	basic 13-109258 BP	2012 IRC	Plan# 33-30.02 H2 - HENLEY3	2-story sfr w/	2014
New	Approved	basic 13-107612 BP	2012 IRC	Plan# Plan# 2457/2DB	2-story sfr w/attached	2014
New	Approved	basic 12-111037 BP	2009 IRC	Plan# 1455	2-story sfr w/attached garağ	2014
New	Approved	basic 12-111036 BP	2009 IRC	Plan# 1618	2-story sfr w/attached ga	2014
New	Approved	basic 14-106989 BP	2012 IRC	Plan# 32-30.02 F2 - Henley29	2-story sfr	2014
New	Revision to issued permit changing basic plan to	Approved basic 13-110883.	2012 IRC.	Plan		2014
New	Approved	basic 14-102234 BP	2012 IRC	Plan# 32-30.02 V - Henley17	2-story sfr w	2014
New	Approved	basic 14-103432 BP	2012 IRC	Plan# 31-30.12 U4 - Heneley20	2-story sfr w	2014
New	Approved	basic 13-109258 BP	2012 IRC	Plan# 33-30.02 H2 - HENLEY3	2-story sfr w/	2014
New	Approved	basic 13-112082 BP	2012 IRC	Plan# 32-30.02 A- Henley7	2-story sfr w/attache	2014
New	Approved	basic 14-106246 BP	2012 IRC	Plan# 34-30.02 H4 - Henley28	2-story sfr	2014
New	Approved	basic 13-110883.	2012 IRC.	Plan # 32-30.02 V - Henley5.	2 story sfr w/ attached	2014
New	Approved	basic 13-113233 BP.	2012 IRC.	Plan #33-30.12 F2 - Henley10.	2 story sfr w/ ati	2014
New	Approved	basic 13-113233 BP.	2012 IRC.	Plan #33-30.12 F2 - Henley10.	2 story sfr w/ ati	2014
New	Approved	basic 14-106242 BP	2012 IRC	Plan# 35-30.02 H (.1) - Henley28	2-story sfr	2014
New	Approved	basic 13-115522 BP.	2012 IRC.	Plan# 33-30.12 A - Henley13.	2 story sfr w/ attacl	2014
New	Approved	basic 13-109803 BP.	2012 IRC.	Plan # 33-30.12 F - Henley4.	2 story sfr w/ attach	2014
New	Approved	basic 13-112081 BP	2012 IRC	Plan# 33-30.02 F2- Henley7	2-story s	2014
New	Approved	basic 14-103884 BP	2012 IRC	Plan# 35-30.02 T3 - Henley22	2-story sfr w/c	2014
New	Two- story SFR attached car garage and covered front porch -		2012 IRC			2014
New	Approved	basic 13-110798.	2012 IRC.	Plan#4048.3.0C	2 story sfr w/ attached	2014
New	Approved	basic 13-111625.	2012 IRC.	Plan# 4249A.	2 story sfr w/ attached	2014
New	Approved	basic 14-100741 BP	2012 IRC	Plan# 22285-02AB	2-story sfr w/attached	2014

Accessory Dwelling Units

Index # - File Name: 1.0022 - Single Family Dwellings Data\_Snohomish County.pdf

New	Approved	14-100739 BP	2012 IRC	PLAN No. 2832-02AB	2 story sfr/wattached garag	2014
New	Approved	basic 13-114161 BP	2012 IRC	Plan# 3301-03ABC	2-story sfr w/attached	2014
New	Approved	basic 13-114160 BP	2012 IRC	Plan# 2533-03AB	2-story sfr w/attacl	2014
New	Approved	basic 13-114160 BP	2012 IRC	Plan# 2533-03AB	2-story sfr w/attacl	2014
New	Approved	basic 13-114161 BP	2012 IRC	Plan# 3301-03ABC	2-story sfr w/attached	2014
New	Approved	basic 14-105820.	IRC 2009.	Plan # 2749-43AB.	2 story sfr w/ attached	2014
New	Approved	14-100739 BP	2012 IRC	PLAN No. 2832-02AB	2 story sfr/wattached garag	2014
New	Approved	basic 13-114672 BP	2012 IRC	Plan# 3310-03AB	2-story sfr w/attachi	2014
New	Approved	basic 13-114672 BP	2012 IRC	Plan# 3310-03AB	2-story sfr w/attachi	2014
New	Approved	basic 13-114159 BP	2012 IRC	Plan# 2512-02AB	2-story sfr w/atta	2014
New	Approved	basic 14-100741 BP	2012 IRC	Plan# 22285-02AB	2-story sfr w/attached	2014
New	Approved	basic 14-107807 BP.	20112 IRC.	Plan # 2358-02 AB.	2 story sfr w/ attached gara	2014
New	Approved	basic 13-114160 BP	2012 IRC	Plan# 2533-03AB	2-story sfr w/attacl	2014
New	Approved	basic 13-114161 BP	2012 IRC	Plan# 3301-03ABC	2-story sfr w/attached	2014
New	Approved	basic 13-114672 BP	2012 IRC	Plan# 3310-03AB	2-story sfr w/attachi	2014
New	Approved	basic 13-114159 BP	2012 IRC	Plan# 2512-02AB	2-story sfr w/atta	2014
New	Approved	basic 13-114672 BP	2012 IRC	Plan# 3310-03AB	2-story sfr w/attachi	2014
New	Approved	basic 13-114161 BP	2012 IRC	Plan# 3301-03ABC	2-story sfr w/attached	2014
New	Approved	basic 13-114672 BP	2012 IRC	Plan# 3310-03AB	2-story sfr w/attachi	2014
New	Approved	basic 13-114672 BP	2012 IRC	Plan# 3310-03AB	2-story sfr w/attachi	2014
New	Approved	basic 13-111938BP	2012 IRC.	Plan # 2311-A.	2 story sfr w/ attached gar	2014
New	Approved	basic 13-112888 BP	2012 IRC.	Plan # 2501-C.	2 story sfr w/ attached garage	2014
New	Approved	basic 13-111939.	2012 IRC.	Plan #2573-A.	2 story sfr w/ attached	2014
New	Approved	basic 13-111937BP	2012 IRC.	Plan #2311-B.	2 story sfr w/ attached garage.	2014
New	Approved	basic 13-111938BP	2012 IRC.	Plan # 2311-A.	2 story sfr w/ attached gar	2014
New	Approved	basic 13-112889 BP.	2012 IRC.	Plan # 2501-B.	2 story sfr w/ attached garage.	2014
New	Approved	basic 13-111937BP	2012 IRC.	Plan #2311-B.	2 story sfr w/ attached garage.	2014
New	Approved	basic 13-111941.	2012 IRC.	Plan #2573-B.	2 story sfr w/ attached garage.	2014
New	Approved	basic 13-112887.	2012 IRC.	Plan # 2501-A.	2 story sfr w/ attached g	2014
New	Approved	basic 13-111939.	2012 IRC.	Plan #2573-A.	2 story sfr w/ attached	2014
New	Approved	basic 13-111937BP	2012 IRC.	Plan #2311-B.	2 story sfr w/ attached garage.	2014
New	Approved	basic 13-112888 BP	2012 IRC.	Plan # 2501-C.	2 story sfr w/ attached garage.	2014
New	Approved	basic 13-111941	2012 IRC.	Plan #2573-B.	2 story sfr w/ attached garage.	2014
New	Approved	basic 13-112889 BP.	2012 IRC.	Plan # 2501-B.	2 story sfr w/ attached garage.	2014
New	Approved	Basic 13-111940.	2012 IRC.	Plan #2573-C.	2 story sfr w/ attached }	2014
New	Approved	basic 13-112891 BP.	2012 IRC.	Plan # 2486-C.	2 story sfr w/ loft and attached ga	2014
New	Approved	basic 13-112889 BP.	2012 IRC.	Plan # 2501-B.	2 story sfr w/ attached garage.	2014
New	Approved	basic 13-111939.	2012 IRC.	Plan #2573-A.	2 story sfr w/ attached	2014
New	Approved	basic 13-112892 BP.	2012 IRC.	Plan #2486-A.	2 story sfr w/ loft and attached }	2014
New	Approved	basic 13-111941.	2012 IRC.	Plan #2573-B.	2 story sfr w/ attached garage.	2014
New	Approved	basic 13-112887.	2012 IRC.	Plan # 2501-A.	2 story sfr w/ attached g	2014
New	Approved	basic 13-111938BP	2012 IRC.	Plan # 2311-A.	2 story sfr w/ attached gar	2014
New	Approved	basic 13-111939.	2012 IRC.	Plan #2573-A.	2 story sfr w/ attached	2014
New	Approved	basic 13-112888 BP.	2012 IRC.	Plan # 2501-C.	2 story sfr w/ attached garage.	2014
New	Approved	Basic 13-111940.	2012 IRC.	Plan #2573-C.	2 story sfr w/ attached }	2014
New	Approved	basic 13-111937BP	2012 IRC.	Plan #2311-B.	2 story sfr w/ attached garage.	2014
New	Approved	basic 13-112889 BP.	2012 IRC.	Plan # 2501-B.	2 story sfr w/ attached garage.	2014

Accessory Dwelling Units

Index # - File Name: 1.0022 - Single Family Dwellings Data\_Snohomish County.pdf

New	Approved	basic 13-111941.	2012 IRC.	Plan #2573-B.	2 story sfr w/ attached garage.	2014
New	Approved	basic 13-112887.	2012 IRC.	Plan # 2501-A.	2 story sfr w/ attached garage.	2014
New	Approved	Basic 13-108398 BP.	2012 IRC.	Plan #448 B.	2 story sfr w/ attached garage.	2014
New	Approved	basic 13-111035 BP	2012 IRC	Plan# 455 AB	2-story sfr w/attached garage	2014
New	Approved	basic 13-111031 BP	2012 IRC	Plan# 446 C	2-story sfr w/attached garage	2014
New	Approved	basic 13-111627.	2012 IRC.	Plan #4249C.	2 story sfr w/ attached garage.	2014
New	Approved	basic 13-111884.	2012 IRC.	Plan # 4264A.	2 story sfr w/ attached garage.	2014
New	Approved	basic 13-110798.	2012 IRC.	Plan#4048.3.0C	2 story sfr w/ attached garage.	2014
New	Approved	basic 13-110887.	2012 IRC.	Plan # 4048.3.0B	2 story sfr w/ attached garage	2014
New	Approved	basic 13-112761 BP.	2012 IRC.	Plan # 4264B.	2 story sfr w/ attached garage. *	2014
New	Approved	basic 13-110797 BP	2012 IRC	Plan# 4048.3.0A	2-story sfr w/attached garage	2014
New		2-story sfr w/attached garage				2014
New		SFR: 2 story style home with attached 3 car garage, 4 bedrooms, 2.5 baths				2014
New		2 story sfr w/ attached garage.				2014
New		Rambler w/ attached garage.				2014
New	Approved	basic 12-103430 BP	2009 IRC	Plan# 2823	2-story sfr w/attached garage	2014
New		SFR, Rambler with 2nd floor loft, 2 bedroom one bath				2014
New		One Story SFR with Attached Garage				2014
New		2385 sf Rambler with attached garage - 2012 IRC				2014
New	Approved	basic 14-109129 BP	2012 IRC	Plan# 24-40.02 F4 - Henley33	2-story sfr w/ attached garage	2014
New	Approved	basic 14-106152.	2012 IRC.	Plan # 31-30.12 F - Henley 27.	2 story sfr w/ attached garage	2014
New	Approved	basic 14-105985 BP	2012 IRC	Plan#24-40.02 XA4 - Henley27	2-story sfr w/ attached garage	2014
New	Approved	basic 14-102307 BP	2012 IRC	Plan# 35-30.02 H - Henley18	2-story sfr w/ attached garage	2014
New	Approved	basic 14-104721 BP	2012 IRC	Plan# 27-40.02 F - Henley23	2-story sfr w/ attached garage	2014
New	Approved	basic 14-102234 BP	2012 IRC	Plan# 32-30.02 V - Henley17	2-story sfr w/ attached garage	2014
New	Approved	basic 14-103012 BP	2012 IRC	Plan# 35-30.03 F - Henley19	2-story sfr w/ attached garage	2014
New	Approved	basic 14-105069 BP	2012 IRC	Plan# 23-40.02 W4 - Henley24	2-story sfr w/ attached garage	2014
New	Approved	basic 14-104069 BP	2012 IRC	Plan# 22-40.02 S5 - Henley22	2-story sfr w/attached garage	2014
New	Approved	basic 13-112656 BP.	2012 IRC.	Plan #34-30.02.	2 story sfr w/ attached garage.	2014
New	Approved	basic 14-100353 BP	2012 IRC	Plan# 32-30.02 A - Henley14	2-story sfr w/attached garage	2014
New	Approved	basic 13-114146 BP	2012 IRC	Plan# 32-30.02 V4 - Henley12	2-story sfr w/attached garage	2014
New	Approved	basic 14-106988 BP	2012 IRC	Plan# 35-30.02 T4 - Henley29	2-story sfr w/ attached garage	2014
New	Approved	basic 14-102236 BP	2012 IRC	Plan# 27-40.02 F2 - Henley17	2-story sfr w/ attached garage	2014
New	Approved	basic 13-111956 BP	2012 IRC	Plan# 34-30.02 P2 - Henley6	2-story sfr w/ attached garage	2014
New	Approved	basic 14-100353 BP	2012 IRC	Plan# 32-30.02 A - Henley14	2-story sfr w/ attached garage	2014
New	Approved	basic 14-113065 BP	2012 IRC	Plan# 32-30.02 V - Henley36	2-story sfr w/ attached garage	2014
New	Approved	basic 13-112656 BP.	2012 IRC.	Plan #34-30.02.	2 story sfr w/ attached garage.	2014
New	Approved	Basic 14-108162 BP	2012 IRC	Plan #35-30.02 J - Henley31	2 story sfr w/attached garage	2014
New	Approved	basic 13-114146 BP	2012 IRC	Plan# 32-30.02 V4 - Henley12	2-story sfr w/attached garage	2014
New	Approved	basic 14-101874.	2012 IRC.	Plan# 35-30.02 F - Henley.	2 story sfr w/ attached garage	2014
New	Approved	basic 14-107622.	2012 IRC.	Plan #31-30.02 P2-0 Henly 30.	2 story sfr w/ attached garage	2014
New	Approved	Basic 14-108157 BP	2012 IRC	Plan #34-30.02 H - Henley31	2 story sfr w/attached garage	2014
New	Approved	basic 14-113065 BP	2012 IRC	Plan# 32-30.02 V - Henley36	2-story sfr w/ attached garage	2014
New	Approved	basic 14-100353 BP	2012 IRC	Plan# 32-30.02 A - Henley14	2-story sfr w/ attached garage	2014
New	Approved	Basic 14-107976 BP	2012 IRC	Plan #34-30.02 P2 (.1) - Henley	2 story sfr w/ attached garage	2014
New	Approved	Basic 14-108152 BP	2012 IRC	Plan #35-30.02 T4 (.1) - Henley31	2 story sfr w/ attached garage	2014
New	Approved	basic 14-101874.	2012 IRC.	Plan# 35-30.02 F - Henley.	2 story sfr w/ attached garage	2014



Accessory Dwelling Units

Index # - File Name: 1.0022 - Single Family Dwellings Data\_Snohomish County.pdf

New	Approved	basic 14-101009 BP	2012 IRC	Plan# 4035B	2-story sfr w/attached g	2014
New	Approved	basic 14-101005 BP	2012 IRC	Plan# 4028A	2-story sfr w/attached ga	2014
New	Approved	basic 14-101007 BP	2012 IRC	Plan# 4028C	2-story sfr w/attached	2014
New	Approved	basic 14-101008 BP	2012 IRC	Plan# 4035A	2-story sfr w/attached ga	2014
New	Approved	basic 14-101010 BP	2012 IRC	Plan# 4035C	2-story sfr w/attached ga	2014
New	Approved	basic 14-101009 BP	2012 IRC	Plan# 4035B	2-story sfr w/attached g	2014
New	Approved	basic 14-101006 BP	2012 IRC	Plan# 4028B	2-story sfr w/attached gara	2014
New	Approved	basic 14-101008 BP	2012 IRC	Plan# 4035A	2-story sfr w/attached ga	2014
New	Approved	basic 13-103961 RK	2009 IRC	Plan# 2160	Two Story Home with attached	2014
New	Approved	Basic 14-101912BP	2012 IRC	Plan# R2192	Ramble-style sfr w/attach	2014
New	Approved	Basic 14-103982 BP	2012 IRC	Plan# 2160	2-story SFR w/attached gar	2014
New	One-story SFR with attached garage and unfinished storage area above garage - 2012 IRC					2014
New	Approved	basic 14-105067 BP	2012 IRC	Plan# 34-30.03 H - Henley24	2-story sfr w,	2014
New	Approved	basic 13-114146 BP	2012 IRC	Plan# 32-30.02 V4 - Henley12	2-story sfr w/ai	2014
New	Approved	basic 13-112660.	2012 IRC.	Plan #24-40.02 F.	2 story sfr w/ attache	2014
New	Approved	basic 13-114762 BP	2012 IRC	Plan# 34-30.02 (.1) - Henley13	2-story sf	2014
New	Approved	basic 13-111836.	2012 IRC.	Plan #31-30.32 V Henley6.	2 story sfr w/ attache	2014
New	Approved	basic 13-115520 BP.	2012 IRC.	Plan # 22-40.02 S2 - Henley13.	2 story sfr w/ att	2014
New	Approved	basic 13-113933 BP.	2012 IRC.	Plan # 25-40.02 A Henley12.	2 story sfr w/attac	2014
New	Approved	basic 13-110883.	2012 IRC.	Plan # 32-30.02 V - Henley5.	2 story sfr w/ attached	2014
New	Approved	basic 13-109799 BP.	2012 IRC.	Plan # 35-30.02 F2 - Henley4.	2 story sfr w/ at	2014
New	2-story sfr w/attached garage					2014
New	Approved	basic 14-101004 BP	2012 IRC	Plan# 3019C	2-story sfr w/attached gara	2014
New	Approved	basic 14-100999 BP	2012 IRC	Plan# 3014B	2-story sfr w/attached ga	2014
New	Approved	basic 14-101004 BP	2012 IRC	Plan# 3019C	2-story sfr w/attached gara	2014
New	Approved	basic 14-100999 BP	2012 IRC	Plan# 3014B	2-story sfr w/attached ga	2014
New	Approved	basic 14-101003 BP	2012 IRC	Plan# 3019A	2-story sfr w/attached ga	2014
New	Approved	basic 14-101004 BP	2012 IRC	Plan# 3019C	2-story sfr w/attached gara	2014
New	Approved	basic 14-101000 BP	2012 IRC	Plan# 3014C	2-story sfr w/attached ga	2014
New	Approved	basic 14-101005 BP	2012 IRC	Plan# 4028A	2-story sfr w/attached ga	2014
New	Approved	basic 14-101004 BP	2012 IRC	Plan# 3019C	2-story sfr w/attached gara	2014
New	Approved	basic 14-100999 BP	2012 IRC	Plan# 3014B	2-story sfr w/attached ga	2014
New	Approved	basic 14-101004 BP	2012 IRC	Plan# 3019C	2-story sfr w/attached gara	2014
New	Approved	basic 14-101003 BP	2012 IRC	Plan# 3019A	2-story sfr w/attached ga	2014
New	Approved	basic 14-100999 BP	2012 IRC	Plan# 3014B	2-story sfr w/attached ga	2014
New	Approved	basic 14-101004 BP	2012 IRC	Plan# 3019C	2-story sfr w/attached gara	2014
New	Approved	basic 14-100999 BP	2012 IRC	Plan# 3014B	2-story sfr w/attached ga	2014
New	Approved	basic 14-101006 BP	2012 IRC	Plan# 4028B	2-story sfr w/attached g	2014
New	Approved	basic 14-101008 BP	2012 IRC	Plan# 4035A	2-story sfr w/attached ga	2014
New	Approved	basic 14-101006 BP	2012 IRC	Plan# 4028B	2-story sfr w/attached gara	2014
New	Approved	basic 14-101009 BP	2012 IRC	Plan# 4035B	2-story sfr w/attached g	2014
New	Approved	basic 14-101007 BP	2012 IRC	Plan# 4028C	2-story sfr w/attached	2014
New	2-story sfr w/attached garage					2014
New	3622 sf rambler with 713 sf attached garage - 2012 IRC					2014
New	Mobile home					2014
New	27 x 56 1997 Fleetwood Berkshire					2014
New	1638 sf rambler-style SFR with 632 sf covered porch - 2012 IRC					2014

Accessory Dwelling Units

Index # - File Name: 1.0022 - Single Family Dwellings Data\_Snohomish County.pdf

New	2-story sfr w/attached garage					2014
New	2-story sfr w/attached garage					2014
New	2-story sfr w/attached garage					2014
New	2-story sfr w/attached garage					2014
New	2-story sfr w/attached garage					2014
New	Approved basic 14-110800 BP	2012 IRC	Plan# 2034 Concord	2-story sfr w/attached		2014
New	One Story SFR with Attached					2014
New	Two Story SFR with Attached Garage					2014
New	1623 sf SFR with attached 534 sf garage - 2012 IRC					2014
New	SFR: two story style home with attached 3 car garage, 4 bedrooms / 4 baths					2014
New	2-story sfr w/attached garage					2014
New	Approved basic 14-111774 BP	2012 IRC	Plan# 3301-03ABC-25ft	2-story sfr w/at		2014
New	**1/9/2019 LRR Expired without County approval to use or occupy** PERMIT EXPIRED WITHOL					2014
New	New 2- story SFR with attached garage on lot created by BLA.			See: 14-111527-LDA		2014
New	Approved basic 14-112491 BP	2012 IRC	Plan# Augusta A	2-story sfr w/attached ga		2014
New	Approved basic 14-114998 BP	2012 IRC	Plan# 22-40.02 S2- Henley39	2-story sfr \		2014
New	Approved basic 14-109167 BP	2012 IRC	Plan# 23-40.02 F4 - Henley34	2-story sfr w/a		2014
New	Approved basic 14-105069 BP	2012 IRC	Plan# 23-40.02 W4 - Henley24	2-story sfr		2014
New	Approved basic 14-109171 BP	2012 IRC	Plan# 34-30.02 U4 - Henley33	2-story sfr w/		2014
New	2570 sf SFR with 662 sf bonus room above garage - 2012 IRC					2014
New	Approved basic 13-112612 BP	2012 IRC	Plan# 3315	2-story sfr w/attached g		2014
New	Two Story SFR with Attached Garage					2014
New	Approved basic 13-109258 BP	2012 IRC	Plan# 33-30.02 H2 - HENLEY3	2-story sfr w/		2014
New	New 2 story SFR w/ attached garage					2014
New	Approved basic 13-115522 BP.	2012 IRC.	Plan # 33-30.12 A - Henley13.	2 story sfr w/ attac		2014
New	Approved basic 14-108819 BP	2012 IRC	Plan# 37-30.02 J - Henley32	2-story sfr		2014
New	Approved basic 14-109259 BP	2012 IRC	Plan# 36-30.02 XC - Henley34	2-story sfr w/i		2014
New	Approved basic 14-103823 BP	2012 IRC	Plan# 31-30.12 H - Henley21	2-story sfr w/atti		2014
New	Approved basic 13-110883.	2012 IRC.	Plan # 32-30.02 V - Henley5.	2 story sfr w/ attached		2014
New	Approved basic 14-109279 BP	2012 IRC	Plan# 35-40.02 U4 - Henley34	2-story sfr w		2014
New	Approved basic 14-106675 BP	2012 IRC	Plan# 33-30.12 F2 - Henley28	2-story sfr w		2014
New	Approved basic 14-100353 BP	2012 IRC	Plan# 32-30.02 A - Henley14	2-story sf		2014
New	Approved basic 13-112659.	2012 IRC.	Plan #34-30.02 H.	2 story sfr w/ attache		2014
New	Approved basic 14-103495 BP	2012 IRC	Plan# 31-30.32 V4 - Henley21	2-story sf		2014
New	Approved basic 14-105203 BP	2012 IRC	Plan# 33-30.12 A4 - Henley25	2-story sfr		2014
New	Approved basic 13-111322.	IRC 2012.	Plan # 35-30.02 F - Henley6.	2 story sfr w/ attached		2014
New	Approved basic 13-114146 BP	2012 IRC	Plan# 32-30.02 V4 - Henley12	2-story sfr w/at		2014
New	Approved basic 13-111956 BP	2012 IRC	Plan# 34-30.02 P2 - Henley6	2-story :		2014
New	Approved basic 13-111322.	IRC 2012.	Plan # 35-30.02 F - Henley6.	2 story sfr w/ attached		2014
New	Approved basic 13-112082 BP	2012 IRC	Plan# 32-30.02 A- Henley7	2-story sfr w/attache		2014
New	Approved basic 13-114147 BP	2012 IRC	Plan 34-30.02 P (.1) - Henley12	2-story sfr w/a		2014
New	Approved basic 14-101874.	2012 IRC.	Plan# 35-30.02 F - Henley.	2 story sfr w/ attache		2014
New	Approved basic 13-107612 BP	2012 IRC	Plan# Plan# 2457/2DB	2-story sfr w/attached		2014
New	SFR, 2 story style home with attached 2 car garage and covered porches, 4 bedroom, 2.5 bath					2014
New	Approved basic 13-112081 BP	2012 IRC	Plan# 33-30.02 F2- Henley7	2-story :		2014
New	Approved basic 14-103823 BP	2012 IRC	Plan# 31-30.12 H - Henley21	2-story sfr w/atti		2014
New	Approved basic 13-110883.	2012 IRC.	Plan # 32-30.02 V - Henley5.	2 story sfr w/ attached		2014

Accessory Dwelling Units

Index # - File Name: 1.0022 - Single Family Dwellings Data\_Snohomish County.pdf

New	New 2 story SFR w/ attached garage. See 13-115398-LDA				2014
New	Approved basic 13-109681 BP	2012 IRC	Plan# Harlequin	2-story sfr w/attached	2014
New	One Story SFR with Attached Garage				2014
New	SFR: rambler style with 2 car garage and covered back deck and covered front porch				2014
New	760 sf sfr with 1183 sf finished lower floor and 824 sf finished basement - 2012 IRC				2014
New	Approved basic 14-107593 BP	2012 IRC	Plan# Cascadia	Rambler style sfr w/bon	2014
New	Approved basic 14-107596 BP	2012 IRC	Plan# Rainier	2-story sfr w/attached gara	2014
New	Approved 14-107707 BP	2012 IRC	Plan# Crystal	2-story sfr w/attached garage	2014
New	Approved basic 14-107587 BP	2012 IRC	Plan# Harvest	2-story sfr w/attached g	2014
New	Approved basic 14-107591 BP	2012 IRC	Plan# Skykomish	Rambler style sfr w/bc	2014
New	Approved basic 14-107588 BP	2012 IRC	Plan# Cassidy	2-story sfr w/attached g	2014
New	Approved basic 14-107589 BP	2012 IRC	Plan# Pilchuck	2-story sfr w/attached ga	2014
New	Approved basic 14-105272 BP	2012 IRC	Plan# 2140 A	2-story sfr w/attached garag	2014
New	Approved basic 14-106417 BP	2012 IRC	Plan# Westbrook	Rambler style sfr v	2014
New	Rambler w/daylight unfinished basement w/attached garage				2014
New	Rambler style sfr w/attached garage w/bonus above				2014
New	228 square foot (12 x 19) raised deck				2014
New	2000 sf rambler with attached garage - 2012 IRC				2014
New	Approved basic 14-101224 BP	2012 IRC	Plan# 2273 A & B Elevation	2-story sfr w/a	2014
New	Approved basic 14-105179 BP	2012 IRC	Plan# 2472 A	2-story sfr w/attached garage	2014
New	Approved basic 14-101224 BP	2012 IRC	Plan# 2273 A & B Elevation	2-story sfr w/a	2014
New	Approved basic 14-105179 BP	2012 IRC	Plan# 2472 A	2-story sfr w/attached garage	2014
New	Approved basic 14-109111 BP	2012 IRC	Plan# 2440 A	2-story sfr w/attached gara	2014
New	Approved basic 14-101837 BP	2012 IRC	Plan# 1500	2-story sfr w/attached garage	2014
New	Approved basic 14-101224 BP	2012 IRC	Plan# 2273 A & B Elevation	2-story sfr w/a	2014
New	Approved basic 14-101224 BP	2012 IRC	Plan# 2273 A & B Elevation	2-story sfr w/a	2014
New	Approved basic 14-105179 BP	2012 IRC	Plan# 2472 A	2-story sfr w/attached garage	2014
New	Approved basic 14-109116 BP	2012 IRC	Plan# 2440 B	2-story sfr w/attached garag	2014
New	Approved basic 14-105272 BP	2012 IRC	Plan# 2140 A	2-story sfr w/attached garag	2014
New	Approved Basic 13-100963. 2009 IRC . Plan # 2304. 2 story sfr w/ attached garage.				2014
New	Approved Basic 13-100961. 2009 IRC . Plan # 2202. 2 story sfr w/ attached garage.				2014
New	Approved Basic 13-100958. 2009 IRC . Plan# 2244. 2 story sfr w/ attached garage.				2014
New	Approved Basic 13-100959. 2009 IRC . Plan # 2162. 2 Story sfr w/ attached garage.				2014
New	Approved Basic 13-100958. 2009 IRC . Plan# 2244. 2 story sfr w/ attached garage.				2014
New	Approved Basic 13-100959. 2009 IRC . Plan # 2162. 2 Story sfr w/ attached garage.				2014
New	Approved Basic 13-100958. 2009 IRC . Plan# 2244. 2 story sfr w/ attached garage.				2014
New	Approved Basic 13-100958. 2009 IRC . Plan# 2244. 2 story sfr w/ attached garage.				2014
New	Approved Basic 13-100963. 2009 IRC . Plan # 2304. 2 story sfr w/ attached garage.				2014
New	Approved Basic 13-100959. 2009 IRC . Plan # 2162. 2 Story sfr w/ attached garage.				2014
New	Approved Basic 13-100958. 2009 IRC . Plan# 2244. 2 story sfr w/ attached garage.				2014
New	Approved Basic 13-100956. 2009 IRC . Plan # 2000. 2 Story SFR w/ attached garage.				2014
New	Approved Basic 13-100963. 2009 IRC . Plan # 2304. 2 story sfr w/ attached garage.				2014
New	Approved Basic 13-100962. 2009 IRC . Plan #2074. 2 story sfr w/ attached garage.				2014
New	New 2174 sf SFR with attached garage. See 13-113558-LDA for associated Land Disturbing Activ				2014
New	Approved basic 12-111037 BP	2009 IRC	Plan# 1455	2-story sfr w/attached garag	2014
New	Approved basic 12-111037 BP	2009 IRC	Plan# 1455	2-story sfr w/attached gara	2014
New	Approved basic 12-111037 BP	2009 IRC	Plan# 1455	2-story sfr w/attached gara	2014

Accessory Dwelling Units

Index # - File Name: 1.0022 - Single Family Dwellings Data\_Snohomish County.pdf

New	2-story duplex w/attached garage					2014
New	Approved basic 12-111037 BP	2009 IRC	Plan# 1455	2-story sfr w/attached garag		2014
New	Approved basic 12-111036 BP	2009 IRC	Plan# 1618	2-story sfr w/attached ga		2014
New	Approved basic 12-111036 BP	2009 IRC	Plan# 1618	2-story sfr w/attached gar		2014
New	Approved basic 12-111037 BP	2009 IRC	Plan# 1455	2-story sfr w/attached garag		2014
New	Approved basic 12-111036 BP	2009 IRC	Plan# 1618	2-story sfr w/attached gar		2014
New	Approved basic 12-111037 BP	2009 IRC	Plan# 1455	2-story sfr w/attached garağ		2014
New	Approved basic 12-111037 BP	2009 IRC	Plan# 1455	2-story sfr w/attached garağ		2014
New	Approved basic 12-111037 BP	2009 IRC	Plan# 1455	2-story sfr w/attached garag		2014
New	Approved basic 12-111037 BP	2009 IRC	Plan# 1455	2-story sfr w/attached garağ		2014
New	Approved basic 12-111037 BP	2009 IRC	Plan# 1455	2-story sfr w/attached garag		2014
New	Approved basic 12-111037 BP	2009 IRC	Plan# 1455	2-story sfr w/attached garağ		2014
New	Approved basic 12-111037 BP	2009 IRC	Plan# 1455	2-story sfr w/attached garag		2014
New	Approved basic 12-111037 BP	2009 IRC	Plan# 1455	2-story sfr w/attached garağ		2014
New	Approved basic 12-111037 BP	2009 IRC	Plan# 1455	2-story sfr w/attached garag		2014
New	Approved basic 12-111037 BP	2009 IRC	Plan# 1455	2-story sfr w/attached garağ		2014
New	2-story sfr w/attached garage					2014
New	2-story sfr w/attached garage					2014
New	2-story sfr w/attached garage					2014
New	2-story sfr w/attached garage					2014
New	Two Story SFR with Attached Garage					2014
New	Approved basic 12-107553 BP	2009 IRC	Plan# Marvin	2-story sfr w/attached gar		2014
New	2-story sfr w/attached garage					2014
New	2-story sfr w/attached garage					2014
New	Approved basic 12-107557 BP	2009 IRC	Plan# James	Rambler style sfr w/attach		2014
New	Approved basic 12-107553 BP	2009 IRC	Plan# Marvin	2-story sfr w/attached ç		2014
New	Approved basic 12-107553 BP	2009 IRC	Plan# Marvin	2-story sfr w/attached gar		2014
New	Rambler style sfr w/attached garage					2014
New	Rambler style sfr w/attached garage					2014
New	Approved basic 12-107553 BP	2009 IRC	Plan# Marvin	2-story sfr w/attached gar		2014
New	Rambler style sfr w/attached garage					2014
New	new 2- story SFR with attached garage					2014
New	SFR, two story with attached garage and covered front porch, 4 bedroom, 2.5 bath					2014
New	2 story sfr w/ attached garage.					2014
New	Two Story SFR with Attached Garage					2014
New	New 2-story SFR w/ attached garage					2014
New	SFR, 2 story with attached 3 car garage					2014
New	Approved basic 13-114560 BP.	2012 IRC.	Plan # 1962	2 story sfr w/ attached garage.		2014
New	Approved basic 13-114560 BP.	2012 IRC.	Plan # 1962	2 story sfr w/ attached garage.		2014
New	2 story sfr w/ attached garage.					2014
New	2-story sfr w/attached garage					2014
New	2509sf SFR with 912sf Attached Garage					2014
New	SFR, two story with attached two car garage					2014
New	New 2-story SFR with attached garage					2014
New	2-story sfr w/attached garage					2014
New	Approved basic 13-112666 BP	2012 IRC	Plan# 2574	2-story sfr w/attached gar		2014
New	Approved basic 13-112666 BP	2012 IRC	Plan# 2574	2-story sfr w/attached gar		2014
New	2-story sfr w/attached garage					2014

Accessory Dwelling Units

Index # - File Name: 1.0022 - Single Family Dwellings Data\_Snohomish County.pdf

New	Ramble style sfr w/attached garage				2014
New	New SFR, rambler style home with attached garage and covered patios, 3 bedroom & 3 bath				2014
New	New SFR, rambler with attached 3 car garage & covered front porch				2014
New	New 2-story SFR w/ attached garage. See 14-109910-LDA				2014
New	Two-story SFR with attached garage 2012 IRC				2014
New	28 x 65 1984 Glen River Radco				2014
New	2-story sfr w/attached garage				2014
New	SFR, two story style home, unfinished basement and attached 3 car garage, 5 bedroom 3.5 bath				2014
New	New SFR rambler with attached garage . See 14-110270-LDA				2014
New	Final inspection for expired SFR permit.				2014
New	SFR, two story style with attached 3 car garage, 4 bedrooms, 3.5 bath				2014
New	Detached Accessory Apartment				2014
New	SFR: rambler style house with attached 3 car garage, 3 bedrooms plus office				2014
New	Single family residence, three story, with attached garage (3 bedrooms) (28 x 45)				2014
New	SFR, two story with attached 2 car garage and covered back porch, 4 bedrooms/2.5 bath				2014
New	SFR, rambler style home with attached 3 car garage, 4 bedroom, 2.5 bath				2014
New	SFR, Rambler with roughed in basement and attached garage				2014
New	new rambler SFR with attached garage & targeted drainage plan. See 13-107777-LDA				2014
New	Two-story SFR with attached garage - 2009 IRC (transferred from Mark Marzolf 2/12/2013)				2014
New	840 sq ft detached accessory apartment				2014
New	SFR, rambler style home with attached garage				2014
New	Two-story SFR with attached garage and carport - 2012 IRC				2014
New	Rambler with attached 3 car garage and covered front porch				2014
New	New SFR consisting of 2981 sq ft living space with 744 sq ft attached garage and 600 deck. Subje				2014
New	Approved basic 14-101359 BP	2012 IRC	Plan# 2541	2-story sfr w/attached g	2014
New	Approved basic 14-112959 BP	2012 IRC	Plan# 3017	2-story sfr w/attached gar	2014
New	Approved basic 14-101359 BP	2012 IRC	Plan# 2541	2-story sfr w/attached g	2014
New	Approved basic 14-101359 BP	2012 IRC	Plan# 2541	2-story sfr w/attached g	2014
New	Approved basic 14-101356 BP	2012 IRC	Plan# 2313	Rambler styl sfr w/	2014
New	Approved basic 14-108687 BP	2012 IRC	Plan# 3049 end load	2-story sfr w/att	2014
New	Approved basic 14-101358 BP	2012 IRC	Plan# 2774	2-story sfr w/attache	2014
New	Approved basic 14-112959 BP	2012 IRC	Plan# 3017	2-story sfr w/attached gara	2014
New	Approved basic 14-101356 BP	2012 IRC	Plan# 2313	Rambler styl sfr w/	2014
New	2-story sfr w/attached garage				2014
New	2-story sfr w/attached garage				2014
New	2-story sfr w/attached garage				2014
New	Two Story SFR with Attached Garage				2014
New	Two-story SFR with attached garage - 2012 IRC				2014
New	Two-story SFR with attached garage - 2012 IRC				2014
New	Two Story SFR with Attached Garage				2014
New	New 2-story SFR with attached garage. SEE: 14-112057-LDA				2014
New	Manufactured home permit, residential, 2013, double wide Marlette, 27 x 48				2014
New	New 2 stroy SFR				2014
New	SFR, new two story home with attached garage, 4 bed/2.5 bath				2014
New	2782 sf rambler - 2012 IRC				2014
New	Two Story SFR with Attached Garage				2014
New	New 2- stroy SFR w/ attached garage. See 14-108706-LDA				2014

Accessory Dwelling Units

Index # - File Name: 1.0022 - Single Family Dwellings Data\_Snohomish County.pdf

New	2-story sfr w/attached garage	2014
New	2-story sfr w/attached garage	2014
New	SFR, two story style home with attached 3 car garage, 4 bedroom 2.5 bath	2014
New	SFR, new two story home with covered front porch and attached 2 car garage, 3 bedrooms/3.5	2014
New	New SFR rambler w/ attached garage. See 14-106859-LDA	2014
New	2-story sfr w/attached garage	2014
New	2-story sfr w/attached garage	2014
New	Two-story SFR with attached garage - 2012 IRC	2014
New	Rambler style sfr w/attached garage	2014
New	Per Tim Elder extend to 10/3/15 for final inspection dm 9/29/15 2 story SFR with unfinished ba	2014
New	(49 X 64 ) 946 sf sfr over 2058 sf horse stable with attached 784 sf garage - 2012 IRC	2014
New	Approved basic 13-107401. 2012 IRC. Plan 3494 4 car. 2 story sfr w/ attached 4 car	2014
New	SFR, new rambler with basement and attached garage, 2 bedroom 2.5 bath	2014
New	Rambler style sfr w/attached garage	2014
New	SFR, 2-story home, 5 bedroom/4 bath, with attached garage and covered porch	2014
New	Two Story SFR	2014
New	New 2-story SFR w/ attached garage. See 14-101219-LDA & 14-100324-D4	2014
New	SFR, two story style with attached 2 car garage, 3 bedrooms 2.5 baths	2014
New	New SFR consisting of 2529 sq ft living space, 551 sq ft attached garage, and 183 sq ft patio/por	2014
New	2013 Goldenwest MH. 70 ft x 30ft	2014
New	SFR, 2 story style with attached 3 car garage, covered patio, bonus room, exercise room, office,	2014
New	4175 sf (approx 80 x 88 -- irregular ) single family residence with attached garage.	2014
New	Approved basic 13-112612 BP 2012 IRC Plan# 3315 2-story sfr w/attached g	2014
New	DEMO OLD SFR AND CONSTRUCT NEW Approved basic 13-112612 BP 2012 IRC	2014
New	Two Story SFR with Attached Garage	2014
New	SFR, rambler with attached 2 car garage and covered front porch	2014
New	New single-family residence 40 x 70 with attached garage, subject to LDA under 14-106774-LD	2014
New	625 square foot detached accessory apartment	2014
New	Two-story SFR with attached garage - 2012 IRC	2014
New	Approved basic 13-114560 BP. 2012 IRC. Plan # 1962 2 story sfr w/ attached garage. Pla	2014
New	Two-story SFR with attached garage - 2012 IRC	2014
New	48 x 40 One Story SFR	2014
New	1660 sf SFR with 948 sf daylight basement and attached garage - 2012 IRC	2014
New	1086sf Rambler	2014
New	One Story SFR with Attached Garage	2014
New	Two-story SFR with attached garage and bonus room	2014
New	Two-story duplex - 2012 IRC	2014
New	Two-story SFR with attached garage - 2012 IRC Plan 2909	2014
New	Demo old SFR and construct new rambler w/ attached garage. See: 14-111207-LDA & 14-11120	2014
New	3718 sf SFR (farm workers dwelling) over 3718 sf garage - 2012 IRC	2014
New	1-story sfr w/attached garage	2014
New	2-story sfr w/attached garage	2014
New	2 - story sfr w/attached garage	2014
New	Rambler style sfr w/daylight basement w/attached garage	2014
New	Mobile Home for 1987 Fleetwood 4562L double-wide.	2014
New	1942 sf Rambler with attached garage - 2012 IRC	2014
New	Split level sfr with 928 sf finished basement attached garage - 2012 IRC	2014

Accessory Dwelling Units

Index # - File Name: 1.0022 - Single Family Dwellings Data\_Snohomish County.pdf

New	New 2-story SFR with attached garage. See 14-110530-LDA	2014
New	Rambler style sfr w/2nd floor bonus room and attached garage	2014
New	2-story sfr with attached garage	2014
New	Two Story SFR with Attached Garage - 2012 IRC	2014
New	Two-story SFR with attached garage - 2012 IRC	2014
New	Rambler style sfr w/attached garage	2014
New	SFR, two story style, 4 bedroom/4 bath with attached 2 car garage	2014
New	Approved basic 14-111016 BP. 2012 IRC. Plan #3292 Rambler w/ attached	2014
New	5/12/16ses-30 day extension (original exp 5/12/16) on permits, ready to final-waiting for letter	2014
New	New 2 story SFR w/ attached garage.See 14-109341-LDA & 14-109343-RK	2014
New	SFR, two story style with attached 3 car garage and covered front porch	2014
New	Approved Basic 14-107564 BP 2012 IRC Plan# SplitA Split level SFR w/attached gara	2014
New	Approved basic 13-114094 BP 2012 IRC Plan# 2200 2-story sfr w/attached	2014
New	2 story sfr w/ daylight basement	2014
New	Demolish old SFR & Construct new 2-story SFR with attached garage. See 14-108347-LDA & 14-1	2014
New	SFR, rambler with attached 3 car garage, 3 bedrooms 2 baths	2014
New	Two-story SFR with attached garage - 2003 IRC	2014
New	New 2- stroy SFR w/ attached garage & Targeted Drainage Plan. See 14- 103626 - LDA Old SFR t	2014
New	Duplex, two story style with attached garage	2014
New	Demo old SFR and construct New 2-story SFR w/ attached garage. . See 14-108329-LDA	2014
New	Rambler style sfr w/attached garage bonus room above	2014
New	1337 sf rambler with 596 sf attached garage - 2012 IRC	2014
New	40 x 58 Single Story SFR	2014
New	SFR, 2 story A-frame style home with finished basement, main floor plus loft area on upper floor	2014
New	Demolish old circa 1923 SFR and build new 2 story SFR with attached garage. See 14-100527- LC	2014
New	2-Story SFR with Attached Garage	2014
New	SFR, two story style with attached 3 car garage, 3 bedrooms 2.5 bath	2014
New	Approved Basic 14-103982 BP 2012 IRC Plan# 2160 2-story SFR w/attached garaç	2014
New	2 story sfr w/ attached garage.	2014
New	40 x 70 2014 Arlington	2014
New	New house, rambler with attached 3 car garage (2 bedroom 2 bath)	2014
New	Two-story SFR with attached garage - 2012 IRC CASP #201403240263	2014
New	Two-story SFR with attached garage - 2013 IRC CASP #201403240262	2014
New	1593 SF Rambler with Attached Garage	2014
New	Rebuild portion of SFR and attached garage due to fire damage	2014
New	SFR, new rambler style home with attached 3 car garage and covered back patio NSF Check - Ac	2014
New	Manufactured home, single wide, 1975 Glenbrook, 14 x 64	2014
New	SFR, rambler style home with attached accessory apartment off garage	2014
New	Two Story SFR with Attached Garage	2014
New	Mobile Home: 1980 double wide, Fleetwood 28 x 64	2014
New	Mobile home permit, 1990, double sided, Buckingham 2106 (26 -8 x 66 )	2014
New	1632 sf rambler with attached garage - 2012 IRC	2014
New	1898 sf rambler with attached garage - 2012 IRC	2014
New	New SFR with attached garage. See 13-111332-LDA. CASP AFN 201404090238	2014
New	Two Story SFR	2014
New	New 2 story SFR with attached garage.See 14-109937-LDA	2014
New	SFR, new rambler style, 3 bedroom/2 bath home with 2 car attached garage	2014

Accessory Dwelling Units

Index # - File Name: 1.0022 - Single Family Dwellings Data\_Snohomish County.pdf

New	SFR with attached garage to be built on inspected and approved foundation.	2014
New	Approved basic 13-114094 BP 2012 IRC Plan# 2200 2-story sfr w/attached	2014
New	SFR, two story style home with attached garage and carport	2014
New	new SFR rambler with attached garage. See 14-103677-LDA & 14-103680-AB	2014
New	One Story SFR with Attached Garage	2014
New	Ownership transfer to Patrick Rommel 4/9/15 SFR with Attached Carport.	2014
New	Two-story SFR - 2012 IRC	2014
New	192 sf detached bedroom with bath and 48 sf covered porch	2014
New	House, new, (replacing existing MH) upper floor unfinished attic storage plus attached 2 car driv	2014
New	New SFR rambler with Targeted Drainage Pla. See 14-108296-LDA. Existing cabin will be conver	2014
New	SFR - rambler style home with attached 2 car garage, 3 bedrooms/2 baths	2014
New	Two-story SFR with attached garage - 2012 IRC	2014
New	Second Story SFR over Garage/Carport	2014
New	Rambler style sfr w/heated storage in daylight basement w/attached garage	2014
New	2 story sfr w/ attached garage	2014
New	850 sq ft detached accessory apartment	2014
New	27 x 64 - 2013 Marlette Mobile Home	2014
New	New one-story SFR consisting of 925 sf of living space.	2014
New	Approved basic 13-112612 BP 2012 IRC Plan# 3315 2-story sfr w/attached g	2014
New	New 2-story SFR with attached garage. See 14-110645-FZ & 14-110646-LDA	2014
New	One-story sfr with attached garage - 2012 IRC	2014
New	Residential building permit application for detached Accessory Apartment	2014
New	Two-story SFR - 2012 IRC	2014
New	Daylight ramber w/attached garage and bonus above	2014
New	Rambler style sfr w/attached garage	2014
New	Rambler style sfr w/daylight basement w/attached garage	2014
New	Approved basic 14-101357 BP 2012 IRC Plan# 1866 Juno Rambler styl e s	2014
New	One story sfr with attached garage	2014
New	New 2-story SFR with attached garage.	2014
New	Two Story SFR on Existing Foundation for Rambler. Only approved inspection for existing SFR ( t	2014
New	New 2-story SFR with attached garage. Existing Cabin and TD to be removed. SEE: 14-113590-I	2014
New	One Story SFR	2014
New	1470sf Rambler	2014
New	Approved basic 14-102134 BP 2012 IRC Plan# 2216 2-story sfr w/attached gara	2014
New	2285 SF Rambler with 672 SF Attached Garage	2014
New	New 2-story SFR w/ attached garage. See 14-105049-LDA	2014
New	Two-story SFR with attached garage - 2012 IRC Plan 3123	2014
New	New 2- story SFR with attached garage SEE:15-107764-LDA	2015
New	FIRE REBUILD- Build new 2-story SFR on existing foundation.	2015
New	1568 s.f. rambler replacing existing mobile home	2015
New	SFR: new two story home with attached 3 car garage, with covered front porch, 4 bedrooms and	2015
New	Approved basic 13-107399. 2012 IRC. Plan 3624-RV. 2 story sfr w/ attached garage	2015
New	2 story sfr w/attached garage	2015
New	Detached Residential Office and Hobby Room with Bathroom and Bar Sink	2015
New	9/26/16ses Customer requests 30 day extention on permit to get to final-expire on 11/3/16 2 s	2015
New	New 1904 SF rambler with attached garage SEE: 15-115501-L	2015
New	SFR: 2 story with attached 12 x 48 carport, garage/shop on main floor with living spaces on 2nd	2015



Accessory Dwelling Units

Index # - File Name: 1.0022 - Single Family Dwellings Data\_Snohomish County.pdf

New	Manufactured Home: 27 x 48 2015 Marlette #2848	2015
New	1615 SF SFR over 682 SF Finished Basement and 721SF Attached Garage with 989 SF Unheated 9	2015
New	Final inspection for expired 98-101909-MH SEE: 15	2015
New	new double wide mobile home	2015
New	1837 sq ft SFR with attached Garage	2015
New	Approved basic 14-101912BP 2012 IRC Plan# R2192 Ramble-style sfr w/attach	2015
New	SFR: Rambler style home with attached 3 car garage, covered front and back porches, 4 bedroom	2015
New	New 2 story SFR Old MH to be removed SEE: 15-106793	2015
New	SFR, rambler style 4 bedroom, office and attached 2 car garage plus bonus room	2015
New	New 26 x 56 double wide mobile home	2015
New	2232 s.f. rambler w/attached garage	2015
New	2362 s.f. rambler w/attached garage	2015
New	8/29/16ses-customer would like 30 day grace period to reach final. SFR: rambler with finished	2015
New	New 1511 s.f. rambler w/attached garage on existing foundation - Fire Damage Repair	2015
New	1492 sf rambler w/468 sf garage and 78 sf covered porch	2015
New	2444 Sq Ft Rambler with 506 Sq Ft Covered Porch	2015
New	Approved basic 13-110770 BP 2012 IRC Plan: 2364 Two-story SFR with attached g	2015
New	27 x 44, 1984 Fleetwood Mobile Home for Cartaker/Staff	2015
New	Approved basic 14-102134 BP 2012 IRC Plan# 2216 2-story sfr w/attached gara	2015
New	Approved basic 13-114094 BP 2012 IRC Plan# 2200 2-story sfr w/attached	2015
New	New 2-story SFR with attached garage.	2015
New	Manufactured Home: 2015, single wide, Marlette, 15 x 44	2015
New	8/17/16ses-Customer requests 30 day extension to get through framing inspection SFR: 2 story	2015
New	27 ft X 50 ft Double Wide Mobile Home	2015
New	1682 s.f. rambler w/attached garage -	2015
New	SFR: 2 story style home with double depth 2 car garage, 3 bedroom 2.5 bath	2015
New	Two Story SFR with Finished Basement	2015
New	2 story sfr w/unfinished basement	2015
New	1142 sq ft Garage w/926 sq ft 2nd story Exercise Room	2015
New	Approved Basic 14-112415 BP 2012 IRC Plan# SplitA-1EL Split level SFR w/attached garag	2015
New	Two-story home w/ attached 2 car garage on existing foundation (foundation permitted under c	2015
New	SFR: 2 story style home with attached 3 car garage, 4 bedroom/3.5 bath	2015
New	2-story single family residence	2015
New	Rebuild cabin on Lake Roesiger	2015
New	10/20/16ses-30 day extension requested so that all documents can be provided for final. Do no	2015
New	2 story sfr w/attached garage	2015
New	Rebuild SFR cabin destroyed by recent fire.	2015
New	Approved basic 14-112454 BP 2012 IRC Plan# 2453 Rambler style sfr w/attach	2015
New	2560 SF rambler style SFR SEE: 15-11281	2015
New	New 2 story SFR with attached garage & carport. See 14-110403-LDA.	2015
New	3246 rambler w/attached garage (612 s.f. 2nd story storage)	2015
New	2 story duplex w/attached garage (replacing existing sfr)	2015
New	2429 SF, 2-story home with 640 sf attached garage and 524 sf covered porch	2015
New	Duplex: 2 story with attached garage	2015
New	Two Story SFR with Attached Garage	2015
New	Approved basic 15-114001 BP 2012 IRC Plan# 1930 Rambler sfr w/attachec	2015
New	SFR: rambler style home with attached 3 car garage	2015

Accessory Dwelling Units

Index # - File Name: 1.0022 - Single Family Dwellings Data\_Snohomish County.pdf

New	New Rambler style SFR with attached garage	SEE: 15-109827-LDA	2015
New	2 story sfr w/garage		2015
New	SFR, Rambler with daylight basement, outdoor covered entertaining area with kitchen, 3 bedroc		2015
New	Approved Basic 14-112415 BP 2012 IRC Plan# SplitA-1EL Split level SFR w/attached gara		2015
New	2 story sfr w/attached garage		2015
New	2 story single family residence - 2012 IRC		2015
New	2423 s.f. Rambler w/attached garage		2015
New	CASP AF# 201509220619 New Rambler style SFR with attached garage	SEE: 15-11	2015
New	Approved basic 13-109681 BP 2012 IRC Plan# Harlequin 2-story sfr w/attached		2015
New	SFR, Rambler style with attached 3 car garage, covered porch, 3 bedrooms and two baths		2015
New	2-story sfr w/attached garage		2015
New	New 1276 s.f. Rambler w/attached garage on partially existing foundation - Fire Damage Repair		2015
New	3361 s.f. Rambler w/attached garage		2015
New	Rambler style sfr w/finished basement w/attached garage		2015
New	Two Story Duplex with Attached Garages		2015
New	CASP AF# 201505010544 New Rambler SFR with attached garage.		2015
New	2365 SF SFR with 2712 SF Finished Basement and Attached Garage		2015
New	2177 sq ft SFR with attached 755 sq ft Garage		2015
New	Single family residence w/unfinished basement and attached garage		2015
New	2001 s.f. Rambler w/attached garage		2015
New	2 story sfr w/attached garage		2015
New	New Duplex - 2 units of 1,741 sf w/ 460 sf garage and 34 sf covered porch		2015
New	2 story sfr w/attached garage		2015
New	2 story sfr w/attached garage		2015
New	Single family residence with daylight basement & attached garage		2015
New	SFR, two story style with attached 2 car garage		2015
New	2 story sfr w/attached garage		2015
New	2 story SFR with unheated basement for storage and attached garage	SEE: 15-110868	2015
New	Approved basic 15-102257 BP 2012 IRC Plan# 1433 2-story sfr w/attached ga		2015
New	New 2-story SFR with finished basement and attached garage. Old MH to be removed within 30		2015
New	Approved basic 15-102227 BP 2012 IRC Plan# 1292-duplex 2-story duplex w/attached g		2015
New	Approved basic 13-112612 BP 2012 IRC Plan# 3315 2-story sfr w/attached ga		2015
New	Approved basic 15-105560 BP 2012 IRC Plan# 3224 2-story sfr w/attached ga		2015
New	House: new 2 story style home with covered front porch and attached 2 car garage, 3 bedroom		2015
New	New house: Rambler style SFR with extra bonus room over 3 car garage		2015
New	Demo old half of duplex and build new half of duplex.	SEE: 15-104060-RK	2015
New	Detached accessory apartment		2015
New	2 story sfr w/detached garage		2015
New	Detached Hobby Room and Home Office with Bathroom and Attached Garage		2015
New	SFR: proposed single family residence. Rambler style home, 3 bedroom home with attached (1 k		2015
New	Approved basic 15-103889 BP 2012 IRC Plan# 1561-duplex 2-story duplex w/attached 2 c		2015
New	2 story single family residence w/attached garage 05/21/2018 DJL- As per Jacqueline this is ok		2015
New	One Story SFR with Attached Garage		2015
New	SFR: two story home with attached 3 car garage, covered porches front and back, 5 bedrooms, !		2015
New	Approved basic 13-112612 BP 2012 IRC Plan# 3315 2-story sfr w/attached ga		2015
New	Approved basic 15-109842 BP 2012 IRC Plan# 3080 B 2-story sfr w/attached gara		2015
New	New 2-story SFR w/ attached garage	SEE: 15-1175	2015

Accessory Dwelling Units

Index # - File Name: 1.0022 - Single Family Dwellings Data\_Snohomish County.pdf

New	Approved basic 13-114094 BP	2012 IRC	Plan# 2200	2-story sfr w/attached	2015
New	Approved basic 13-107399.	2012 IRC.	Plan 3624-RV.	2 story sfr w/ attached garage	2015
New	14 x 56 Liberty/ Ridgeway, Single Wide Mobile Home on Vacant Property				2015
New	New 2 story SFR with attached garage			SEE: 15-107032-LDA and	2015
New	Approved basic 13-107401.	2012 IRC.	Plan 3494 4 car.	2 story sfr w/ attached 4 ca	2015
New	SFR: 2 story with attached 3 car garage and covered front porch & covered back patio				2015
New	SFR: 2-story style home with 4 bedrooms, plus den and separate bonus room and attached 3 ca				2015
New	2229 SF Rambler with 801 SF Attached Garage and 520 SF Covered Porch				2015
New	2 story sfr w/attached garage				2015
New	Approved basic 13-101858 BP	2009 IRC	Plan# 2200	2-story sfr w/attached }	2015
New	Two story SFR with attached Garage				2015
New	SFR, Two story home with attached 3 car garage				2015
New	2 story sfr w/attached garage applicant changed contractor name listed on the application to B				2015
New	1666 s.f. rambler w/attached garage Right to Practice Forestry AF# 201509210325				2015
New	New rambler SFR & attached garage				2015
New	New 2-story SFR with attached garage			SEE: 15-111505-LDA	2015
New	SFR: single story A-frame style home with attached 2 car garage				2015
New	New 2 story home with attached garage and covered porch, 4 bedroom 3.5 bath				2015
New	Manufactured Home: 2015, double wide, Majestic (27 x 64)				2015
New	2 story sfr w/ attached garage.				2015
New	SFR: new 2 story with covered front and back patios and attached 3 car garage. 4 bedrooms 3 b				2015
New	New SFR rambler with attached garage. See 14-111503-LDA				2015
New	Approved basic 14-101912BP	2012 IRC	Plan# R2192	Ramble-style sfr w/attach	2015
New	2-story sfr w/attached garage				2015
New	2325 sf SFR with 454 sf bonus room over 742 sf garage - 2012 IRC				2015
New	2 - story sfr w/attached garage				2015
New	New rambler SFR with attached garage. SEE: 14-116462-LDA				2015
New	Two Story SFR with Attached Garage				2015
New	Two Story SFR with Attached Garage				2015
New	Two Story SFR with Attached Garage				2015
New	2-story sfr w/attached garage				2015
New	Approved basic 15-107154 BP	2012 IRC	Plan# 3656 Daylight	Rambler styl	2015
New	Approved basic 15-107154 BP	2012 IRC	Plan# 3656 Daylight	Rambler style	2015
New	Approved basic 15-107154 BP	2012 IRC	Plan# 3656 Daylight	Rambler style	2015
New	Approved basic 15-107154 BP	2012 IRC	Plan# 3656 Daylight	Rambler styl	2015
New	Approved basic 15-101470 BP	2012 IRC	Plan# 2578	Single story sfr w/attached	2015
New	Approved basic 14-101358 BP	2012 IRC	Plan# 2774	2-story sfr w/attache	2015
New	Approved basic 15-101470 BP	2012 IRC	Plan# 2578	Single story sfr w/attached	2015
New	2 story sfr w/attached garage				2015
New	New rambler style SFR with attached garage			Ref: 15-106390-LDA	2015
New	New 2-story SFR with attached garage			SEE: 15-113234-LDA	2015
New	New 2 story SFR with attached garage.				2015
New	SFR: two story home with 3 car garage, 4 bedroom, 2nd floor game room, 3 bathrooms				2015
New	Rambler with Attached Garage				2015
New	Approved basic 13-114094 BP	2012 IRC	Plan# 2200	2-story sfr w/attached	2015
New	SFR: 2 story style home with attached 3 car garage, 4 bedroom / 2.5 baths				2015
New	2735 rambler w/attached garage				2015

Accessory Dwelling Units

Index # - File Name: 1.0022 - Single Family Dwellings Data\_Snohomish County.pdf

New	Rambler style sfr w/attached garage				2015
New	2-story sfr w/attached garage				2015
New	Approved basic 15- 102257 BP	2012 IRC	Plan# 1443	2-story sfr w/attached ga	2015
New	Basic Duplex	15-103376-BP		Plan#1335-Du	2015
New	Two Story SFR with Unfinished Basement and Attached Garage				2015
New	Manufactured Home: double wide, 1994, Nashua Castlewood 28 x 56				2015
New	SFR - Two story style home with attached 3 car garage. Covered front and back porches, with bc				2015
New	converting unfinished basement to attached accessory apartment				2015
New	One Story SFR with Attached Garage				2015
New	****WITHDRAWN PER APPLICANT ON 9/2/15****			SEE: 15-113654-RK Approved basic	2015
New	2-story SFR with attached garage			SEE:15-107717-RK (FOUNDATION)	2015
New	SFR: new 2 story home with attached 2 car garage, 4 bedroom plus loft on upper floor and offic				2015
New	Rambler style sfr w/attached garage and bonus above				2015
New	Rambler style sfr w/attached garage and bonus above				2015
New	1650sq ft SFR with 1650sq ft Unfinished Basement,, 321sq ft Second Floor 315sq ft Covered Por				2015
New	Two Story SFR with Attached Garage				2015
New	2 story sfr w/attached garage				2015
New	New rambler SFR with finished basement and attached garage				2015
New	SFR w/daylight basement				2015
New	2 story single family residence w/attached garages				2015
New	2 story sfr w/attached garage				2015
New	2 story sfr w/attached garage ***Extended expiration date for 30 days per Ed Devoe***				2015
New	Two Story SFR with Attached Garage				2015
New	Approved basic 15-109698 BP	2012 IRC	Plan# 1460	2-story sfr w/attached garage	2015
New	Approved basic 15-109698 BP	2012 IRC	Plan# 1460	2-story sfr w/attached garage	2015
New	Approved basic 15-109698 BP	2012 IRC	Plan# 1460	2-story sfr w/attached garage	2015
New	Approved basic 15-109698 BP	2012 IRC	Plan# 1460	2-story sfr w/attached garage	2015
New	Approved basic 15-109698 BP	2012 IRC	Plan# 1460	2-story sfr w/attached garage	2015
New	Approved basic 15-109698 BP	2012 IRC	Plan# 1460	2-story sfr w/attached garage	2015
New	Approved basic 15-109698 BP	2012 IRC	Plan# 1460	2-story sfr w/attached garage	2015
New	New 2-story SFR with attached garage.				2015
New	SFR: 2 story style with 3 car garage, covered front entry porch and covered back outdoor living s				2015
New	Approved basic 13-109681 BP	2012 IRC	Plan# Harlequin	2-story sfr w/attached	2015
New	Approved basic 14-105272 BP	2012 IRC	Plan# 2140 A	2-story sfr w/attached garag	2015
New	Approved basic 14-105275 BP	2012 IRC	Plan# 2140 B	2-story sfr w/attached garag	2015
New	2 story sfr w/attached garage				2015
New	SFR: 2 story style home with attached 3 car garage, 4 bedroom, 2.5 bath				2015
New	2 story sfr w/attached garage				2015
New	Approved basic 14-107586 BP	2012 IRC	Plan# Armstrong	2-story sfr w/attache	2015
New	Approved basic 14-107586 BP	2012 IRC	Plan# Armstrong	2-story sfr w/attached	2015
New	Approved basic 14-107596 BP	2012 IRC	Plan# Rainier	2-story sfr w/attached gara	2015
New	Approved 14-107708 BP	2012 IRC	Plan# Stevens	2-story sfr w/attached gara	2015
New	Approved basic 14-107588 BP	2012 IRC	Plan# Cassidy	2-story sfr w/attached g	2015
New	Approved basic 14-107591 BP	2012 IRC	Plan# Skykomish	Rambler style sfr w/bc	2015
New	Approved basic 14-107589 BP	2012 IRC	Plan# Pilchuck	2-story sfr w/attached ga	2015
New	Approved basic 14-107586 BP	2012 IRC	Plan# Armstrong	2-story sfr w/attached	2015
New	Approved basic 14-107596 BP	2012 IRC	Plan# Rainier	2-story sfr w/attached gara	2015

Accessory Dwelling Units

Index # - File Name: 1.0022 - Single Family Dwellings Data\_Snohomish County.pdf

New	Approved basic 14-107591 BP	2012 IRC	Plan# Skykomish	Rambler style sfr w/bc	2015
New	EXPIRED WITHOUT COUNTY APPROVAL TO USE OR OCCUPY- 06/05/2017 DJL	Approved basic			2015
New	Approved 14-107708 BP	2012 IRC	Plan# Stevens	2-story sfr w/attached gara	2015
New	Approved basic 15-108428 BP	2012 IRC	Plan# Glacier Peak	Rambler style w/attached 3	2015
New	Approved basic 14-107593 BP	2012 IRC	Plan# Cascadia	Rambler style sfr w/bon	2015
New	Approved 14-107708 BP	2012 IRC	Plan# Stevens	2-story sfr w/attached garag	2015
New	NEW PLANS SUBMITTED 7/23/15 (SEE 15-110869 RK)	All inspection to be compelted under this			2015
New	Revision to issued permit 14-113092 RK	All inspections to be completed under 14-113092 RK.			2015
New	SFR: Rambler style home with attached 3 car garage (4 bedrooms/2.5 baths)				2015
New	Approved basic 14-107591 BP	2012 IRC	Plan# Skykomish	Rambler style sfr w/bc	2015
New	EXPIRED WITHOUT COUNTY APPROVAL TO USE OR OCCUPY- 06/05/2017 DJL	Approved basic			2015
New	New 2-story SFR with attached garage	BASIC # 14-107591-BP			2015
New	Approved basic 14-107589 BP	2012 IRC	Plan# Pilchuck	2-story sfr w/attached ga	2015
New	Approved 14-107708 BP	2012 IRC	Plan# Stevens	2-story sfr w/attached gara	2015
New	Approved basic 15-107753 BP	2012 IRC	Plan# 2265	Rambler w/attached garage	2015
New	Approved basic 14-107588 BP	2012 IRC	Plan# Cassidy	2-story sfr w/attached ga	2015
New	Approved basic 14-107596 BP	2012 IRC	Plan# Rainier	2-story sfr w/attached gara	2015
New	Approved 14-107707 BP	2012 IRC	Plan# Crystal	2-story sfr w/attached garagi	2015
New	Approved basic 14-107589 BP	2012 IRC	Plan# Pilchuck	2-story sfr w/attached ga	2015
New	2 story sfr w/attached garage				2015
New	SFR: rambler style home with 2 car garage, 3 bedroom / 2 bath				2015
New	Rambler style sfr w/attached garage				2015
New	Approved basic 15-115308 BP	2012 IRC	Plan# 1823	2-story sfr w/attached	2015
New	Approved basic 15-115784 BP	2012 IRC	Plan# 1870	2-story sfr w/attached	2015
New	Approved basic 15-115784 BP	2012 IRC	Plan# 1870	2-story sfr w/attached	2015
New	Approved basic 15-115786 BP	2012 IRC	Plan# 1758	2-story sfr w/attache	2015
New	Approved basic 15-115309 BP	2012 IRC	Plan# 1662	2-story sfr w/attache	2015
New	Approved basic 15-115309 BP	2012 IRC	Plan# 1662	2-story sfr w/attache	2015
New	Approved basic 15-115308 BP	2012 IRC	Plan# 1823	2-story sfr w/attached }	2015
New	Approved basic 15-115786 BP	2012 IRC	Plan# 1758	2-story sfr w/attache	2015
New	New rambler style SFR with attached garage	SEE: 15-105449-LDA			2015
New	New 3002 SF Rambler with attached garage.	SEE: 15-102002-RK & 15-102003-LDA			2015
New	Approved basic 14-106849 BP	2012 IRC	Plan# 2254	2-story sfr w/attached gar	2015
New	Approved basic 14-106849 BP	2012 IRC	Plan# 2254	2-story sfr w/attached gar	2015
New	Approved Basic 14-109986 BP	2012 IRC	Plan 23-40.03 F4 - Henley35	2 story sfr w/a	2015
New	Single family residence w/daylight basement and attached garage				2015
New	Approved basic 14-101874.	2012 IRC.	Plan# 35-30.02 F - Henley.	2 story sfr w/ attache	2015
New	Approved basic 14-114966 BP	2012 IRC	Plan# 31-30.32 V - Henley38	2-story sfr w,	2015
New	Approved Basic 14-108162 BP	2012 IRC	Plan #35-30.02 J - Henley31	2 story sfr w/at	2015
New	Approved basic 15-100713 BP	2012 IRC	Plan# 23-40.02 F - Henley41	2-story sfr w/at	2015
New	Approved basic 13-113678 BP	2012 IRC	Plan# 27-40.02 W4- Henley11	2-story sfr w	2015
New	Appoved basic 15-106320 BP	2012 IRC	Plan# 23-40.02 J - Henley47	2-story sfr w/att	2015
New	Approved basic 14-114993 BP	2012 IRC	Plan# 2600 A 12IRC	2-story sfr w/attache	2015
New	Approved basic 14-109111 BP	2012 IRC	Plan# 2440 A	2-story sfr w/attached garag	2015
New	Approved basic 14-115975 BP	2012 IRC	Plan# 23-40.02 W4 - Henley40	2-story sfi	2015
New	Approved basic 15-108813 BP	2012 IRC	Plan# 6-50.06 - F Henley51	2-story sfr '	2015
New	Approved basic 14-114967 BP	2012 IRC	Plan# 31-30.12 T - Henley38	2-story sfr w	2015

Accessory Dwelling Units

Index # - File Name: 1.0022 - Single Family Dwellings Data\_Snohomish County.pdf

New	Approved basic 13-111937BP	2012 IRC.	Plan #2311-B.	2 story sfr w/ attached garage.	2015
New	Approved basic 13-112887.	2012 IRC.	Plan # 2501-A.	2 story sfr w/ attached garage.	2015
New	Approved basic 15-103241 BP	2012 IRC	Plan# 2137-A	2-story sfr w/attached garage	2015
New	Approved basic 15-112646 BP	2012 IRC	Plan#2501 B	2-story sfr w/attached garage	2015
New	Approved basic 13-111873BP	2012 IRC.	Plan#2137-A.	2 story sfr w/ attached garage	2015
New	Approved basic 15-112647 BP	2012 IRC	Plan# 2501 C	2-story sfr w/attached garage	2015
New	Approved basic 15-112606 BP	2012 IRC	Plan# 2311 B	2-story sfr w/attached garage	2015
New	Approved Basic 13-111940.	2012 IRC.	Plan #2573-C.	2 story sfr w/ attached garage	2015
New	Approved basic 15-112646 BP	2012 IRC	Plan# 2501 B	2-story sfr w/attached garage	2015
New	Approved basic 13-111873BP	2012 IRC.	Plan#2137-A.	2 story sfr w/ attached garage	2015
New	Approved basic 15-112606 BP	2012 IRC	Plan# 2311 B	2-story sfr w/attached garage	2015
New	Approved basic 15-112645 BP	2012 IRC	Plan# 2501 A	2-story sfr w/attached garage	2015
New	Approved basic 13-111873BP	2012 IRC.	Plan#2137-A.	2 story sfr w/ attached garage	2015
New	Approved basic 13-111937BP	2012 IRC.	Plan #2311-B.	2 story sfr w/ attached garage.	2015
New	Approved basic 13-112887.	2012 IRC.	Plan # 2501-A.	2 story sfr w/ attached garage.	2015
New	New SFR w/ attached garage.	SEE: 15-100395-LDA		**Trail Permit being applied	2015
New	Approved basic 15-107266 BP	2012 IRC	Plan# 5-50.06 T2 - Henley49	2-story sfr	2015
New	Approved basic 14-101920 BP	2012 IRC	Plan# 21-40.12 XB2 - Henley42	2-story sfr w/	2015
New	Approved basic 15-108761 BP	2012 IRC	Plan# 20-40.02 F - Henley50	2-story sfr	2015
New	Approved basic 14-109292 BP	2012 IRC	Plan# 22-40.02 S5 - Henley34	2-story sfr w/	2015
New	Approved basic 15-102771 BP	2012 IRC	Plan# 24-40.02 T - Henley42	2-story sfr w/at	2015
New	Approved basic 14-109283 BP	2012 IRC	Plan# 22-40.02 A - Henley34	2-story sfr w/	2015
New	Approved basic 14-109167 BP	2012 IRC	Plan# 23-40.02 F4 - Henley34	2-story sfr w/	2015
New	Approved basic 14-114966 BP	2012 IRC	Plan# 31-30.32 V - Henley38	2-story sfr w/	2015
New	Approved basic 15-117492 BP	2012 IRC	Plan# 31-30.12 F - Henley55	2-story sfr	2015
New	Approved basic 15-110297 BP	2012 IRC	Plan# 6-50.06 F2 - Henley52	2-story sfr w/	2015
New	Approved basic 15-112532 BP	2012 IRC	Plan# 24-40.02 XA - Henley55	2-story sfr w/	2015
New	Approved basic 15-100713 BP	2012 IRC	Plan# 23-40.02 F - Henley41	2-story sfr w/at	2015
New	Approved Basic 14-108157 BP	2012 IRC	Plan #34-30.02 H - Henley31	2 story sfr w/	2015
New	Approved basic 14-104721 BP	2012 IRC	Plan# 27-40.02 F - Henley23	2-story sfr w/	2015
New	Approved basic 14-109172 BP	2012 IRC	Plan# 24-40.02 F2 - Henley33	2-story sfr w/	2015
New	Approved basic 15-116101 BP	2012 IRC	Plan# 20-40.02 F2 - Henley56	2-story sfr	2015
New	Approved basic 15-100713 BP	2012 IRC	Plan# 23-40.02 F - Henley41	2-story sfr w/a	2015
New	Approved basic 15-106260 BP	2012 IRC	Plan# 31-30.32 H2- Henley46	2-story sfr w/	2015
New	Approved basic 15-107010 BP	2012 IRC	Plan# 34-30.03 T - Henley47	2-story sfr	2015
New	Approved basic 15-106423 BP	2012 IRC	Plan# 24-40.02 F4 - Henley47	2-story sfr w/	2015
New	Approved basic 15-102867 BP	2012 IRC	Plan# 31-30.13 H - Henley43	2-story sfr w/a	2015
New	Approved basic 15-102922 BP	2012 IRC	Plan# 37-40.02 S2 - Henley44	2-story sfr	2015
New	Approved basic 14-114966 BP	2012 IRC	Plan# 31-30.32 V - Henley38	2-story sfr w/	2015
New	Approved basic 15-103931 BP	2012 IRC	Plan# 21-40.02 XA- Henley45	2-story sfr	2015
New	Approved basic 14-109172 BP	2012 IRC	Plan# 24-40.02 F2 - Henley33	2-story sfr w/	2015
New	Approved basic 14-114967 BP	2012 IRC	Plan# 31-30.12 T - Henley38	2-story sfr w/	2015
New	Approved basic 14-102236 BP	2012 IRC	Plan# 27-40.02 F2 - Henley17	2-story sfr	2015
New	804SF One Story SFR with 70SF Covered Deck and 224SF Uncovered Deck				2015
New	Approved basic 14-112937 BP	2012 IRC	Plan# 456 AB	2-story sfr w/attached garage	2015
New	Approved basic 14-113866 BP	2012 IRC	Plan# 495 C	2-story sfr w/attached garage	2015
New	Approved basic 14-115110 BP	2012 IRC	Plan# Okanogan B-B3	2-story sfr w/attached garage	2015

Accessory Dwelling Units

Index # - File Name: 1.0022 - Single Family Dwellings Data\_Snohomish County.pdf

New	Approved basic 14-114212 BP	2012 IRC	Plan# Paradise B	2-story sfr w/attached g	2015
New	Approved basic 14-114266 BP	2012 IRC	Plan# Brooks A-A3	2-story sfr w/attached	2015
New	Approved basic 14-115110 BP	2012 IRC	Plan# Okanogan B-B3	2-story sfr w/attach	2015
New	Approved basic 14-114212 BP	2012 IRC	Plan# Paradise B	2-story sfr w/attached g	2015
New	Approved basic 14-112939 BP	2012 IRC	Plan# 448 B	2-story sfr w/attached garage	2015
New	Approved basic 14-112936 BP	2012 IRC	Plan# 455 AB	2-story sfr w/attached garag	2015
New	Approved basic 14-112938 BP	2012 IRC	Plan# 448 A	2-story sfr w/attached garage	2015
New	Approved basic 14-110370 BP	2012 IRC	Plan# 2261-38-9	2-story sfr w/att	2015
New	Approved basic 15-100063 BP	2012 IRC	Plan# 2418-30-9	2-story sfr w/attached g	2015
New	Approved basic 15-100063 BP	2012 IRC	Plan# 2418-30-9	2-story sfr w/attached	2015
New	Approved basic 15-100062 BP	2012 IRC	Plan# 2070-30-9	2-story sfr w/attached g	2015
New	Approved basic 15-100067 BP	2012 IRC	Plan# 2006-40-9	2-story sfr w/attached gara	2015
New	Approved basic 14-113307 BP	2012 IRC	Plan# 2368-40-9	2-story sfr w/attached ga	2015
New	Approved basic 15-100067 BP	2012 IRC	Plan# 2006-40-9	2-story sfr w/attached gara	2015
New	Approved basic 14-113304 BP	2012 IRC	Plan# 2662.-40-9	2-story sfr w/attached gara	2015
New	Approved basic 14-110370 BP	2012 IRC	Plan# 2261-38-9	2-story sfr w/att	2015
New	Approved basic 14-110369 BP	2012 IRC	Plan# 2083-4-9	2-story sfr w/attached	2015
New	Approved basic 14-113307 BP	2012 IRC	Plan# 2368-40-9	2-story sfr w/attached ga	2015
New	Approved basic 14-113304 BP	2012 IRC	Plan# 2662.-40-9	2-story sfr w/attached gara	2015
New	Approved basic 14-113306 BP	2012 IRC	Plan# 3138	2-story sfr w/attached garage	2015
New	Approved basic 14-113304 BP	2012 IRC	Plan# 2662.-40-9	2-story sfr w/attached gara	2015
New	Approved basic 14-113306 BP	2012 IRC	Plan# 3138	2-story sfr w/attached garage	2015
New	Approved basic 14-113304 BP	2012 IRC	Plan# 2662.-40-9	2-story sfr w/attached gara	2015
New	Approved basic 14-113307 BP	2012 IRC	Plan# 2368-40-9	2-story sfr w/attached ga	2015
New	Approved basic 14-110370 BP	2012 IRC	Plan# 2261-38-9	2-story sfr w/att	2015
New	Approved basic 14-113304 BP	2012 IRC	Plan# 2662.-40-9	2-story sfr w/attached gara	2015
New	Approved basic 14-113307 BP	2012 IRC	Plan# 2368-40-9	2-story sfr w/attached ga	2015
New	Approved basic 14-110369 BP	2012 IRC	Plan# 2083-4-9	2-story sfr w/attached	2015
New	Approved basic 14-113307 BP	2012 IRC	Plan# 2368-40-9	2-story sfr w/attached ga	2015
New	Approved basic 14-113304 BP	2012 IRC	Plan# 2662.-40-9	2-story sfr w/attached gara	2015
New	Approved basic 15-100067 BP	2012 IRC	Plan# 2006-40-9	2-story sfr w/attached gara	2015
New	Approved basic 13-111939.	2012 IRC.	Plan #2573-A.	2 story sfr w/ attached	2015
New	Approved basic 13-112887.	2012 IRC.	Plan # 2501-A.	2 story sfr w/ attached g;	2015
New	Approved basic 13-111937BP	2012 IRC.	Plan #2311-B.	2 story sfr w/ attached garage.	2015
New	Approved basic 15-103241 BP	2012 IRC	Plan# 2137-A	2-story sfr w/attached gai	2015
New	Approved basic 15-103241 BP	2012 IRC	Plan# 2137-A	2-story sfr w/attached gai	2015
New	Approved Basic 14-108162 BP	2012 IRC	Plan #35-30.02 J - Henley31	2 story sfr w/at	2015
New	Approved basic 14-102307 BP	2012 IRC	Plan# 35-30.02 H - Henley18	2-story sfr v	2015
New	Approved basic 15-111601 BP	2012 IRC	Plan# 31-30.12 F2 - Henley54	2-story sfr w/	2015
New	Approved basic 14-109171 BP	2012 IRC	Plan# 34-30.02 U4 - Henley33	2-story sfr w/	2015
New	Approved basic 15-110635 BP	2012 IRC	Plan# 31-30.32 V - Henley53	2-story sfr w	2015
New	Approved basic 14-105067 BP	2012 IRC	Plan# 34-30.03 H - Henley24	2-story sfr w/	2015
New	Approved basic 15-110061 BP	2012 IRC	Plan# 31-30.33 V - Henley51	2-story sfr w	2015
New	Approved basic 15-115888 BP	2012 IRC	Plan# 21-40.02 XB - Henley53	2-story	2015
New	Approved basic 14-109882 BP	2012 IRC	Plan# 2115	Rambler style sfr w/atta	2015
New	Approved 15-106657 BP	2012 IRC	Plan# 2685	2-story sfr w/attached garag	2015
New	Approved basic 14-109886 BP	2012 IRC	Plan# 2322	Rambler style sfr w/attached g	2015

Accessory Dwelling Units

Index # - File Name: 1.0022 - Single Family Dwellings Data\_Snohomish County.pdf

New	1448 SFR over 970 sf garage and 126 sf covered porch				2015
New	2-story sfr w/attached garage				2015
New	SFR: 2 story style home with attached 3 car garage, 3 bedroom, 2.5 bath, open loft space over v				2015
New	SFR, new rambler style with partially finished basement, attached 3 car garage, 4 bedrooms, 3.5				2015
New	Rambler style sfr w/attached garage				2015
New	2 story sfr w/attached garage				2015
New	2 story sfr w/attached garage				2015
New	Approved basic 14-101912BP	2012 IRC	Plan# R2192	Rambler-style SFR w/attach	2015
New	2118 s.f. rambler w/attached garage				2015
New	Approved basic 15-106943 BP	2012 IRC	Plan# 3212	2-story sfr w/attached gara	2015
New	Approved basic 15-106945 BP	2012 IRC	Plan# 2974	2-story sfr w/attached gara	2015
New	Approved basic 15-106942 BP	2012 IRC	Plan# 2766	Rambler sfr w/attached ga	2015
New	Approved basic 14-106849 BP	2012 IRC	Plan# 2254	2-story sfr w/attached gar	2015
New	1492 s.f. rambler w/2 car garage				2015
New	Approved basic 15-105560 BP	2012 IRC	Plan# 3224	2-story sfr w/attached gi	2015
New	Approved basic 15-106946 BP	2012 IRC	Plan# 3602	2-story sfr w/attached gara	2015
New	Approved basic 15-106946 BP	2012 IRC	Plan# 3602	2-story sfr w/attached gara	2015
New	Two Story SFR with Finished Basement and Attached Garage				2015
New	Approved basic 14-101224 BP	2012 IRC	Plan# 2273 A & B Elevation	2-story sfr w/a	2015
New	Approved basic 14-105181 BP	2012 IRC	Plan# 2472 B	2-story sfr w/attached garage	2015
New	Approved basic 14-101224 BP	2012 IRC	Plan# 2273 A & B Elevation	2-story sfr w/a	2015
New	Approved basic 14-105179 BP	2012 IRC	Plan# 2472 A	2-story sfr w/attached garage	2015
New	Approved basic 14-101224 BP	2012 IRC	Plan# 2273 A & B Elevation	2-story sfr w/a	2015
New	Approved basic 14-105181 BP	2012 IRC	Plan# 2472 B	2-story sfr w/attached garage	2015
New	Approved basic 14-101224 BP	2012 IRC	Plan# 2273 A & B Elevation	2-story sfr w/a	2015
New	Approved basic 14-101224 BP	2012 IRC	Plan# 2273 A & B Elevation	2-story sfr w/a	2015
New	Notice of Right to Practice Forestry recorded. AFN 201508130155			2-story sfr w/attached garage	2015
New	Approved basic 13-112889 BP.	2012 IRC.	Plan # 2501-B.	2 story sfr w/ attached garage.	2015
New	Approved basic 14-113583 BP	2012 IRC	Plan# 2825-C	2-story sfr w/attached garage	2015
New	Approved basic 14-113401 BP	2012 IRC	Plan# 3017C	2-story sfr w/attach	2015
New	Approved basic 13-112887.	2012 IRC.	Plan # 2501-A.	2 story sfr w/ attached gi	2015
New	Approved basic 14-113580 BP	2012 IRC	Plan# 2825-A	2-story sfr w/attached garage	2015
New	Approved basic 13-112889 BP.	2012 IRC.	Plan # 2501-B.	2 story sfr w/ attached garage.	2015
New	Approved basic 14-113582 BP	2012 IRC	Plan# 2825-B	2-story sfr w/attached garage	2015
New	Approved basic 14-109191BP.	2012 IRC.	Plan # 3183-C.	2 story sfr w/ attache	2015
New	Approved basic 13-112888 BP.	2012 IRC.	Plan # 2501-C.	2 story sfr w/ attached garage.	2015
New	Approved basic 14-109192 BP.	2012 IRC.	Plan # 3183-B.	2 story sfr w/ attache	2015
New	Approved basic 14-113399 BP	2012 IRC	Plan# 3017A	2-story sfr w/attached garage	2015
New	Approved basic 14-113583 BP	2012 IRC	Plan# 2825-C	2-story sfr w/attached garage	2015
New	Approved basic 14-113400 BP	2012 IRC	Plan# 3017B	2-story sfr w/attach	2015
New	Approved basic 14-113582 BP	2012 IRC	Plan# 2825-B	2-story sfr w/attached garage	2015
New	Approved basic 15-112658 BP	2012 IRC	Plan# 3183 A	2-story sfr w/attached garage	2015
New	Approved basic 15-112661 BP	2012 IRC	Plan# 3183 C	2-story sfr w/attached garage	2015
New	Approved basic 14-113401 BP	2012 IRC	Plan# 3017C	2-story sfr w/attach	2015
New	Approved basic 14-109189 BP.	2012 IRC.	Plan # 3181-A.	2 story sfr w/ attache	2015
New	Approved basic 14-113399 BP	2012 IRC	Plan# 3017A	2-story sfr w/attached garage	2015
New	Approved basic 15-108595 BP	2012 IRC	Plan# 2702 A	2-story sfr w/attached g	2015



Accessory Dwelling Units

Index # - File Name: 1.0022 - Single Family Dwellings Data\_Snohomish County.pdf

New	SFR with Finished Basement and Attached Garage					2015
New	Approved basic 14-110827 BP	2012 IRC	Plan# Selkirk B	2-story sfr w/attached garage		2015
New	Approved basic 15-107152 BP	2012 IRC	Plan# Dayton D	2-story sfr w/attached garage		2015
New	Approved basic 13-114756 BP	2012 IRC	Plan# Rainier-B	2-story sfr w/attached garage		2015
New	Approved basic 15-106735 BP	2012 IRC	Plan# Hazelwood 1730 A	2-story sfr w/attached garage		2015
New	Approved basic 14-110820 BP	2012 IRC	Plan# Hazelwood B	2-story sfr w/attached garage		2015
New	Approved basic 14-106795 BP	2012 IRC	Plan# Granite -A	2-story sfr w/attached garage		2015
New	Approved basic 15-106384 BP	2012 IRC	Plan# Jefferson C	2-story sfr w/attached garage		2015
New	Approved basic 15-107150 BP	2012 IRC	Plan# Wrangell C	2-story sfr w/attached garage		2015
New	Approved basic 13-114583 BP	2012 IRC	Plan# Kimball-A	2-story sfr w/attached garage		2015
New	Approved basic 15-114195 BP	2012 IRC	Plan# Teton D	2-story sfr w/attached garage		2015
New	Approved basic 15-110459 BP	2012 IRC	Plan# Campbell II C	2-story sfr w/attached garage		2015
New	Approved basic 15-110113 BP	2012 IRC	Plan# Hazelwood-C	2-story sfr w/attached garage		2015
New	Approved basic 15-107150 BP	2012 IRC	Plan# Wrangell C	2-story sfr w/attached garage		2015
New	Approved basic 15-107152 BP	2012 IRC	Plan# Dayton D	2-story sfr w/attached garage		2015
New	Approved basic 15-102332 BP	2012 IRC	Plan# Rainier C	2-story sfr w/attached garage		2015
New	Approved basic 15-111287 BP	2012 IRC	Plan# Granite C	2-story sfr w/attached garage		2015
New	Approved basic 15-103225 BP	2012 IRC	Plan# 3814	2-story sfr w/attached garage		2015
New	Approved basic 13-108744 BP.	2012 IRC.	Plan # 3815-B.	2 story sfr w/ attached garage		2015
New	Approved basic 15-103225 BP	2012 IRC	Plan# 3814	2-story sfr w/attached garage		2015
New	Approved basic 13-108745 BP.	2012 IRC.	Plan # 3815-A.	2 story sfr w/ attached garage		2015
New	Approved basic 15-106732 BP	2012 IRC	Plan# 4T07-B	3-story sfr w/attached garage		2015
New	Approved basic 14-114500 BP	2012 IRC	Plan# Denison A	2-story sfr w/attached garage		2015
New	Approved basic 14-112833 BP	2012 IRC	Plan# Augusta B	2-story sfr w/attached garage		2015
New	Approved basic 14-112823 BP	2012 IRC	Plan# Russell B	2-story sfr w/attached garage		2015
New	Approved basic 14-112491 BP	2012 IRC	Plan# Augusta A	2-story sfr w/attached garage		2015
New	Approved basic 14-112821 BP	2012 IRC	Plan# Russell A	2-story sfr w/attached garage		2015
New	New SFR rambler with attached garage.		SEE: 15-101180-LDA & 14-115799-D4			2015
New	Approved basic 14-112298 BP	2012 IRC	Plan# 417 ABCD	2-story sfr w/attached garage		2015
New	Approved basic 14-110307 BP	2012 IRC	Plan# 456 AB	2-story sfr w/attached garage		2015
New	Approved basic 13-106890 BP	2012 IRC	Plan# 467 A	2-story sfr w/attached garage		2015
New	Approved basic 14-105272 BP	2012 IRC	Plan# 2140 A	2-story sfr w/attached garage		2015
New	Approved basic 14-105275 BP	2012 IRC	Plan# 2140 B	2-story sfr w/attached garage		2015
New	Approved basic 14-105276 BP	2012 IRC	Plan# 2140 C	2-story sfr w/attached garage		2015
New	Approved basic 14-109111 BP	2012 IRC	Plan# 2440 A	2-story sfr w/attached garage		2015
New	Approved basic 14-114993 BP	2012 IRC	Plan# 2600 A 12IRC	2-story sfr w/attached garage		2015
New	Approved basic 14-105276 BP	2012 IRC	Plan# 2140 C	2-story sfr w/attached garage		2015
New	Approved basic 14-109111 BP	2012 IRC	Plan# 2440 A	2-story sfr w/attached garage		2015
New	Approved basic 14-115478 BP	2012 IRC	Plan# 2600 B	2-story sfr w/attached garage		2015
New	Approved basic 14-114993 BP	2012 IRC	Plan# 2600 A 12IRC	2-story sfr w/attached garage		2015
New	Approved basic 14-115478 BP	2012 IRC	Plan# 2600 B	2-story sfr w/attached garage		2015
New	Approved basic 14-101224 BP	2012 IRC	Plan# 2273 A & B Elevation	2-story sfr w/attached garage		2015
New	Approved basic 14-105179 BP	2012 IRC	Plan# 2472 A	2-story sfr w/attached garage		2015
New	Approved basic 14-115478 BP	2012 IRC	Plan# 2600 B	2-story sfr w/attached garage		2015
New	Approved basic 14-101224 BP	2012 IRC	Plan# 2273 A & B Elevation	2-story sfr w/attached garage		2015
New	Approved basic 14-109111 BP	2012 IRC	Plan# 2440 A	2-story sfr w/attached garage		2015
New	Approved basic 14-105276 BP	2012 IRC	Plan# 2140 C	2-story sfr w/attached garage		2015

Accessory Dwelling Units

Index # - File Name: 1.0022 - Single Family Dwellings Data\_Snohomish County.pdf

New	Approved basic 15-109996 BP	2012 IRC	Plan# Pilchuck C/D daylight	2-story sfr w/a	2015
New	Approved basic 14-116493 BP	2012 IRC	Plan# Baker C daylight	2-story sfr w/daylight	2015
New	Approved basic 15-105754 BP	2012 IRC	Plan# Russell D	2-story sfr w/attach	2015
New	Approved basic 15-109996 BP	2012 IRC	Plan# Pilchuck C/D daylight	2-story sfr w/a	2015
New	Approved basic 14-116494 BP	2012 IRC	Plan# Baker D Daylight	2-story sfr w/daylight	2015
New	Approved basic 15-105752 BP	2012 IRC	Plan# Russell C	2-story sfr w/attached	2015
New	Approved basic 15-105754 BP	2012 IRC	Plan# Russell D	2-story sfr w/attach	2015
New	Approved basic 15-109996 BP	2012 IRC	Plan# Pilchuck C/D daylight	2-story sfr w/a	2015
New	Approved basic 15-114371 BP	2012 IRC	Plan# Mason D	2-story sfr w/attache	2015
New	Approved basic 15-112656 BP	2012 IRC	Plan# Cascade C	2-story sfr w/attached g	2015
New	Approved basic 15-105752 BP	2012 IRC	Plan# Russell C	2-story sfr w/attache	2015
New	Approved basic 15-106745 BP	2012 IRC	Plan# Baker C	2-story sfr w/attached gara	2015
New	Approved basic 15-106740 BP	2012 IRC	Plan# Blakely C	2-story sfr w/attached gara	2015
New	Approved basic 15-112654 BP	2012 IRC	Plan# Mason C	2-story sfr w/attached ga	2015
New	Approved basic 14-116033 BP	2012 IRC	Plan# Chelan II C	2-story sfr w/attached g	2015
New	Approved basic 15-112656 BP	2012 IRC	Plan# Cascade C	2-story sfr w/attached g	2015
New	Approved basic 15-112654 BP	2012 IRC	Plan# Mason C	2-story sfr w/attached ga	2015
New	Approved basic 13-110032 BP.	2012 IRC.	Plan # 471 AB.	2 story sfr w/ attached garage.	2015
New	Approved basic 14-110307 BP	2012 IRC	Plan# 456 AB	2-story sfr w/attached g	2015
New	Approved basic 13-110032 BP.	2012 IRC.	Plan # 471 AB.	2 story sfr w/ attached garage.	2015
New	Approved basic 14-110307 BP	2012 IRC	Plan# 456 AB	2-story sfr w/attached g	2015
New	Approved basic 14-110307 BP	2012 IRC	Plan# 423 A	2-story sfr w/attached ga	2015
New	Approved basic 13-110032 BP.	2012 IRC.	Plan # 471 AB.	2 story sfr w/ attached garage.	2015
New	Approved basic 13-111178BP	2012 IRC	Plan# 423 B	2-story sfr w/attached gara	2015
New	Approved basic 13-110032 BP.	2012 IRC.	Plan # 471 AB.	2 story sfr w/ attached garage.	2015
New	Approved Basic 13-112612 BP	2012 IRC	Plan# 3315	2-story sfr w/attached g	2015
New	Approved basic 14-113545 BP	2012 IRC	Plan# 2708-02AB	2-story sfr w/attached g	2015
New	Approved basic 14-108698 BP	2012 IRC	Plan# 2384-02AB	2-story w/attached g	2015
New	Approved basic 14-108698 BP	2012 IRC	Plan# 2384-02AB	2-story w/attached g	2015
New	Approved basic 14-113545 BP	2012 IRC	Plan# 2708-02AB	2-story sfr w/attached g	2015
New	Approved 14-100739 BP	2012 IRC	PLAN No. 2832-02AB	2 story sfr/wattached gara	2015
New	Approved basic 14-111774 BP	2012 IRC	Plan# 3301-03ABC-25ft	2-story sfr w/at	2015
New	Approved 14-100739 BP	2012 IRC	PLAN No. 2832-02AB	2 story sfr/wattached gara	2015
New	Approved basic 14-111774 BP	2012 IRC	Plan# 3301-03ABC-25ft	2-story sfr w/at	2015
New	Approved basic 14-108696 BP	2012 IRC	Plan# 2512-02AB-25ft	2-story sfr w/attac	2015
New	Approved 14-100739 BP	2012 IRC	PLAN No. 2832-02AB	2 story sfr/wattached gara	2015
New	Approved basic 14-108696 BP	2012 IRC	Plan# 2512-02AB-25ft	2-story sfr w/attac	2015
New	Approved 14-100739 BP	2012 IRC	PLAN No. 2832-02AB	2 story sfr/wattached gara	2015
New	Approved basic 15-109882 BP	2012 IRC	Plan# 2368-03AB	2-story sfr w/attached g	2015
New	Approved basic 14-111774 BP	2012 IRC	Plan# 3301-03ABC-25ft	2-story sfr w/at	2015
New	Approved 14-100739 BP	2012 IRC	PLAN No. 2832-02AB	2 story sfr/wattached gara	2015
New	Approved basic 14-108696 BP	2012 IRC	Plan# 2512-02AB-25ft	2-story sfr w/attac	2015
New	Approved basic 14-113545 BP	2012 IRC	Plan# 2708-02AB	2-story sfr w/attached g	2015
New	Approved basic 14-108698 BP	2012 IRC	Plan# 2384-02AB	2-story w/attached g	2015
New	Approved basic 14-108698 BP	2012 IRC	Plan# 2384-02AB	2-story w/attached g	2015
New	Approved basic 14-108698 BP	2012 IRC	Plan# 2384-02AB	2-story w/attached g	2015
New	Approved basic 14-113545 BP	2012 IRC	Plan# 2708-02AB	2-story sfr w/attached g	2015

Accessory Dwelling Units

Index # - File Name: 1.0022 - Single Family Dwellings Data\_Snohomish County.pdf

New	Rambler style sfr w/attached garage					2015
New	1728 rambler w/attached garage					2015
New	New rambler SFR with attached garage					2015
New	1482 rambler w/attached garage					2015
New	1977 s.f. rambler w/attached garage					2015
New	Rambler style sfr w/attached garage					2015
New	1864 rambler w/attached garage					2015
New	New SFR rambler with attached garage					2015
New	Rambler style sfr w/attached garage					2015
New	1482 sf rambler w/attached garage					2015
New	Rambler style sfr w/attached garage					2015
New	New SFR, single story with attached garage					2015
New	Approved basic 14-102134 BP	2012 IRC	Plan# 2216	2-story sfr w/attached gara		2015
New	Approved basic 14-102134 BP	2012 IRC	Plan# 2216	2-story sfr w/attached gara		2015
New	Approved basic 14-109116 BP	2012 IRC	Plan# 2440 B	2-story sfr w/attached garag		2015
New	Approved basic 14-101224 BP	2012 IRC	Plan# 2273 A & B Elevation	2-story sfr w/a		2015
New	Approved basic 14-114993 BP	2012 IRC	Plan# 2600 A 12IRC	2-story sfr w/attache		2015
New	Approved basic 14-105272 BP	2012 IRC	Plan# 2140 A	2-story sfr w/attached garag		2015
New	2-story sfr w/attached garage					2015
New	Approved basic 14-112454 BP	2012 IRC	Plan# 2453	Rambler style sfr w/attacl		2015
New	Approved basic 14-112454 BP	2012 IRC	Plan# 2453	Rambler style sfr w/attacl		2015
New	Approved basic 13-109608 BP	2012 IRC	Plan# 3727-B	2-story sfr w/attached gar		2015
New	Approved basic 13-109474 BP	2012 IRC	Plan# 4710-B	2-story sfr w/attached garağ		2015
New	Approved basic 15-105231 BP	2012 IRC	Plan#3745-A	2-story sfr w/attached garage		2015
New	Approved basic 13-109607 BP	2012 IRC	Plan# 3727-A	2-story sfr w/attached gar		2015
New	Approved basic 13-109473 BP	2012 IRC	Plan# 4710-A	2-story sfr w/attached garag		2015
New	Approved basic 15-105232 BP	2012 IRC	Plan#3745-B	2-story sfr w/attached garage		2015
New	Approved basic 13-109608 BP	2012 IRC	Plan# 3727-B	2-story sfr w/attached gar		2015
New	Approved basic 13-109474 BP	2012 IRC	Plan# 4710-B	2-story sfr w/attached garağ		2015
New	Approved basic 15-105231 BP	2012 IRC	Plan#3745-A	2-story sfr w/attached garage		2015
New	Approved basic 13-109607 BP	2012 IRC	Plan# 3727-A	2-story sfr w/attached gar		2015
New	Approved basic 15-105232 BP	2012 IRC	Plan#3745-B	2-story sfr w/attached garage		2015
New	Approved basic 13-109473 BP	2012 IRC	Plan# 4710-A	2-story sfr w/attached garag		2015
New	Approved basic 13-109473 BP	2012 IRC	Plan# 4710-A	2-story sfr w/attached garag		2015
New	Approved basic 14-106766 BP	2012 IRC	Plan#4723A	2-story sfr w/attached garage		2015
New	Approved basic 14-106767 BP	2012 IRC	Plan#4723B	2-story sfr w/attached garage		2015
New	Approved basic 13-109608 BP	2012 IRC	Plan# 3727-B	2-story sfr w/attached gar		2015
New	Approved basic 13-109608 BP	2012 IRC	Plan# 3727-B	2-story sfr w/attached gar		2015
New	Approved basic 13-109474 BP	2012 IRC	Plan# 4710-B	2-story sfr w/attached garağ		2015
New	Approved basic 15-103469 BP	2012 IRC	Plan# 3831-B	2-story sfr w/attached ga		2015
New	Approved basic 14-106766 BP	2012 IRC	Plan#4723A	2-story sfr w/attached garage		2015
New	Approved basic 15-103468 BP	2012 IRC	Plan# 3831-A	2-story sfr w/attached ga		2015
New	Approved basic 14-106767 BP	2012 IRC	Plan#4723B	2-story sfr w/attached garage		2015
New	Approved basic 15-105232 BP	2012 IRC	Plan#3745-B	2-story sfr w/attached garage		2015
New	Approved basic 13-109607 BP	2012 IRC	Plan# 3727-A	2-story sfr w/attached gar		2015
New	Approved basic 15-105231 BP	2012 IRC	Plan#3745-A	2-story sfr w/attached garage		2015
New	Approved basic 13-109474 BP	2012 IRC	Plan# 4710-B	2-story sfr w/attached garağ		2015

Accessory Dwelling Units

Index # - File Name: 1.0022 - Single Family Dwellings Data\_Snohomish County.pdf

New	Approved basic 15-103468 BP	2012 IRC	Plan# 3831-A	2-story sfr w/attached ga	2015
New	Approved basic 14-106767 BP	2012 IRC	Plan#4723B	2-story sfr w/attached garage	2015
New	Approved basic 15-103469 BP	2012 IRC	Plan# 3831-B	2-story sfr w/attached ga	2015
New	Approved basic 14-106766 BP	2012 IRC	Plan#4723A	2-story sfr w/attached garage	2015
New	Approved basic 15-105232 BP	2012 IRC	Plan#3745-B	2-story sfr w/attached garage	2015
New	Approved basic 13-109473 BP	2012 IRC	Plan# 4710-A	2-story sfr w/attached garag	2015
New	Approved basic 15-103469 BP	2012 IRC	Plan# 3831-B	2-story sfr w/attached ga	2015
New	Approved basic 14-106766 BP	2012 IRC	Plan#4723A	2-story sfr w/attached garage	2015
New	Approved basic 13-109474 BP	2012 IRC	Plan# 4710-B	2-story sfr w/attached gara	2015
New	Permit transfer from Reinke to Robinson 12/29/15 cst 870 sf SFR with 870 sf garage and with 6				2015
New	New 2-story SFR with attached garage. SEE: 14-115603-LDA				2015
New	Two Story SFR with Attached Garage				2015
New	SFR, two story home with upstairs bonus room, attached 3 car garage and front covered porch,				2015
New	SFR: Rambler style home with attached 3 car garage and covered back patio, 3 bedrooms, 3 bat				2015
New	2370 SF Rambler with Attached Garage				2015
New	Rambler style sfr w/attached garage and daylight basement				2015
New	2 story sfr w/attached garage				2015
New	2 story sfr w/attached garage				2015
New	2 story sfr w/attached garage				2015
New	2 story sfr w/attached garage				2015
New	2 story sfr w/attached garage				2015
New	2 story w/attached garage				2015
New	2 story sfr w/attached garage				2015
New	Approved basic 14-112512 BP	2012 IRC	Plan# H330-B	2-story sfr w/attached ga	2015
New	2 story sfr w/attached garage				2015
New	2 story sfr w/attached garage				2015
New	2 story sfr w/finished basement and attached garage				2015
New	2 story sfr w/finished basement and attached garage				2015
New	2-story sfr w/attached garage				2015
New	2-story sfr w/attached garage				2015
New	2-story sfr w/attached garage				2015
New	2-story sfr w/attached garage				2015
New	2-story sfr w/attached garage				2015
New	Approved basic 14-112454 BP	2012 IRC	Plan# 2453	Rambler style sfr w/attacl	2015
New	2-story sfr w/attached garage				2015
New	Approved basic 15-101713 BP	2012 IRC	Plan# Mason B	2-story sfr w/attached gar	2015
New	1638 sf rambler-style SFR with 632 sf covered porch - 2012 IRC				2015
New	Approved basic 14-108596 BP	2012 IRC	Plan# 2540	2-story sfr w/attache	2015
New	Approved 14-100739 BP	2012 IRC	PLAN No. 2832-02AB	2 story sfr/wattached garag	2015
New	Approved basic 14-109882 BP	2012 IRC	Plan# 2115	Rambler style sfr w/atta	2015
New	Approved basic 14-109886 BP	2012 IRC	Plan# 2322	Rambler style sfr w/attached g	2015
New	Daylight rambler w/attached garage				2015
New	Approved 15-106657 BP	2012 IRC	Plan# 2685	2-story sfr w/attached garag	2015
New	Approved basic 15-106657 BP	2012 IRC	Plan# 2685	2-story sfr w/attached }	2015
New	Approved basic 15-102721 BP	2012 IRC	Plan# 2220	Rambler style sfr w/attah	2015
New	Approved basic 14-109886 BP	2012 IRC	Plan# 2322	Rambler style sfr w/attached g	2015
New	Approved basic 15-108670 BP	2012 IRC	Plan# 2100	Rambler style sfr v	2015

Accessory Dwelling Units

Index # - File Name: 1.0022 - Single Family Dwellings Data\_Snohomish County.pdf

New	Ramble style sfr w/daylight basement w/attached garage				2015
New	2-story sfr w/attached garage				2015
New	Approved basic 14-108591 BP	2012 IRC	Plan# 3234	2-story sfr w/attached garage	2015
New	Approved basic 15-103522 BP	2012 IRC	Plan# 3040	2-story sfr w/attached garage	2015
New	SFR, 2 story with covered front porch, attached 3 car garage, 4 bedrooms and 2.5 baths				2015
New	Approved basic 14-101009 BP	2012 IRC	Plan# 4035B	2-story sfr w/attached garage	2015
New	Approved basic 14-101005 BP	2012 IRC	Plan# 4028A	2-story sfr w/attached garage	2015
New	Approved basic 14-101003 BP	2012 IRC	Plan# 3019A	2-story sfr w/attached garage	2015
New	Approved basic 14-101000 BP	2012 IRC	Plan# 3014C	2-story sfr w/attached garage	2015
New	Approved basic 14-101004 BP	2012 IRC	Plan# 3019C	2-story sfr w/attached garage	2015
New	Approved basic 14-100999 BP	2012 IRC	Plan# 3014B	2-story sfr w/attached garage	2015
New	Approved basic 14-101000 BP	2012 IRC	Plan# 3014C	2-story sfr w/attached garage	2015
New	Approved basic 14-101003 BP	2012 IRC	Plan# 3019A	2-story sfr w/attached garage	2015
New	Approved basic 14-101004 BP	2012 IRC	Plan# 3019C	2-story sfr w/attached garage	2015
New	Approved basic 14-101000 BP	2012 IRC	Plan# 3014C	2-story sfr w/attached garage	2015
New	Approved basic 14-101004 BP	2012 IRC	Plan# 3019C	2-story sfr w/attached garage	2015
New	Approved basic 14-101003 BP	2012 IRC	Plan# 3019A	2-story sfr w/attached garage	2015
New	Approved basic 14-101000 BP	2012 IRC	Plan# 3014C	2-story sfr w/attached garage	2015
New	Approved basic 14-101004 BP	2012 IRC	Plan# 3019C	2-story sfr w/attached garage	2015
New	Approved basic 14-100999 BP	2012 IRC	Plan# 3014B	2-story sfr w/attached garage	2015
New	Approved basic 14-101003 BP	2012 IRC	Plan# 3019A	2-story sfr w/attached garage	2015
New	Approved basic 14-101000 BP	2012 IRC	Plan# 3014C	2-story sfr w/attached garage	2015
New	Approved basic 14-101003 BP	2012 IRC	Plan# 3019A	2-story sfr w/attached garage	2015
New	Approved basic 14-100999 BP	2012 IRC	Plan# 3014B	2-story sfr w/attached garage	2015
New	Approved basic 14-101004 BP	2012 IRC	Plan# 3019C	2-story sfr w/attached garage	2015
New	Approved basic 14-101000 BP	2012 IRC	Plan# 3014C	2-story sfr w/attached garage	2015
New	Approved basic 14-101003 BP	2012 IRC	Plan# 3019A	2-story sfr w/attached garage	2015
New	Approved basic 14-108597 BP	2012 IRC	Plan# 2440	2-story sfr w/attached garage	2015
New	Approved basic 14-108590 BP	2014 IRC	Plan# 2750	2-story sfr w/attached garage	2015
New	Approved basic 14-108594 BP	2012 IRC	Plan# 2604	2-story sfr w/attached garage	2015
New	Approved basic 15-103522 BP	2012 IRC	Plan# 3040	2-story sfr w/attached garage	2015
New	Approved basic 14-108594 BP	2012 IRC	Plan# 2604	2-story sfr w/attached garage	2015
New	Approved basic 14-108596 BP	2012 IRC	Plan# 2540	2-story sfr w/attached garage	2015
New	Approved basic 14-114536 BP	2012 IRC	Plan# 2169	2-story sfr w/attached garage	2015
New	Approved basic 14-108592 BP	2012 IRC	Plan# 2850	2-story sfr w/attached garage	2015
New	Approved basic 14-108590 BP	2014 IRC	Plan# 2750	2-story sfr w/attached garage	2015
New	Approved basic 15-103522 BP	2012 IRC	Plan# 3040	2-story sfr w/attached garage	2015
New	Approved basic 14-108592 BP	2012 IRC	Plan# 2850	2-story sfr w/attached garage	2015
New	Approved basic 14-108591 BP	2012 IRC	Plan# 3234	2-story sfr w/attached garage	2015
New	Approved basic 14-108596 BP	2012 IRC	Plan# 2540	2-story sfr w/attached garage	2015
New	Approved basic 14-108596 BP	2012 IRC	Plan# 2540	2-story sfr w/attached garage	2015
New	Approved basic 15-103522 BP	2012 IRC	Plan# 3040	2-story sfr w/attached garage	2015
New	Approved basic 14-108592 BP	2012 IRC	Plan# 2850	2-story sfr w/attached garage	2015
New	Approved basic 14-108591 BP	2012 IRC	Plan# 3234	2-story sfr w/attached garage	2015
New	Approved basic 14-108592 BP	2012 IRC	Plan# 2850	2-story sfr w/attached garage	2015
New	2-story sfr w/attached garage				2015
New	Approved basic 15-103522 BP	2012 IRC	Plan# 3040	2-story sfr w/attached garage	2015

Accessory Dwelling Units

Index # - File Name: 1.0022 - Single Family Dwellings Data\_Snohomish County.pdf

New	Approved basic 14-108592 BP	2012 IRC	Plan# 2850	2-story sfr w/attached	2015
New	Approved basic 14-108591 BP	2012 IRC	Plan# 3234	2-story sfr w/attached ga	2015
New	Approved basic 14-108590 BP	2014 IRC	Plan# 2750	2-story sfr w/attached gara	2015
New	Approved basic 14-108592 BP	2012 IRC	Plan# 2850	2-story sfr w/attached	2015
New	Approved basic 14-108594 BP	2012 IRC	Plan# 2604	2-story sfr w/attached	2015
New	Approved basic 14-108592 BP	2012 IRC	Plan# 2850	2-story sfr w/attached	2015
New	2-story sfr w/attached garage				2015
New	Approved basic 14-114536 BP	2012 IRC	Plan# 2169	2-story sfr w/attached gara	2015
New	Approved basic 14-114536 BP	2012 IRC	Plan# 2169	2-story sfr w/attached gara	2015
New	Approved basic 14-108596 BP	2012 IRC	Plan# 2540	2-story sfr w/attached	2015
New	Approved basic 14-108597 BP	2012 IRC	Plan# 2440	2-story sfr w/attached g	2015
New	Approved basic 14-108594 BP	2012 IRC	Plan# 2604	2-story sfr w/attached	2015
New	Approved basic 14-108591 BP	2012 IRC	Plan# 3234	2-story sfr w/attached ga	2015
New	Approved basic 14-108594 BP	2012 IRC	Plan# 2604	2-story sfr w/attached	2015
New	Approved basic 14-108592 BP	2012 IRC	Plan# 2850	2-story sfr w/attached	2015
New	Approved basic 14-108590 BP	2014 IRC	Plan# 2750	2-story sfr w/attached gara	2015
New	Approved basic 14-108592 BP	2012 IRC	Plan# 2850	2-story sfr w/attached	2015
New	Approved basic 14-108597 BP	2012 IRC	Plan# 2440	2-story sfr w/attached g	2015
New	Approved basic 14-108596 BP	2012 IRC	Plan# 2540	2-story sfr w/attached	2015
New	Approved basic 14-108596 BP	2012 IRC	Plan# 2540	2-story sfr w/attached	2015
New	Approved basic 15-112661 BP	2012 IRC	Plan# 3183 C	2-story sfr w/attached garage	2015
New	Approved basic 15-112658 BP	2012 IRC	Plan# 3183 A	2-story sfr w/attached garage	2015
New	Approved basic 15-108595 BP	2012 IRC	Plan# 2702 A	2-story sfr w/attached g	2015
New	Approved basic 15-112661 BP	2012 IRC	Plan# 3183 C	2-story sfr w/attached garage	2015
New	Approved basic 15-114054 BP	2012 IRC	Plan# 3182B	2-story sfr w/attached	2015
New	Approved basic 14-113400 BP	2012 IRC	Plan# 3017B	2-story sfr w/attache	2015
New	Approved basic 15-108595 BP	2012 IRC	Plan# 2702 A	2-story sfr w/attached g	2015
New	Approved basic 14-113399 BP	2012 IRC	Plan# 3017A	2-story sfr w/attached garage	2015
New	Approved basic 15-112645 BP	2012 IRC	Plan# 2501 A	2-story sfr w/attached garage	2015
New	Approved basic 14-113399 BP	2012 IRC	Plan# 3017A	2-story sfr w/attached garage	2015
New	Approved basic 15-105619 BP	2012 IRC	Plan# 4T06-B	3-story sfr w/attached gara	2015
New	Approved basic 15-106731 BP	2012 IRC	Plan# 4T07-A	3-story sfr w/attached ga	2015
New	Approved basic 13-108744 BP.	2012 IRC.	Plan # 3815-B.	2 story sfr w/ attache	2015
New	Approved basic 15-105618 BP	2012 IRC	Plan# 4T06-A	3-story sfr w/attached gara	2015
New	Approved basic 15-106732 BP	2012 IRC	Plan# 4T07-B	3-story sfr w/attached g	2015
New	Approved basic 15-106731 BP	2012 IRC	Plan# 4T07-A	3-story sfr w/attached ga	2015
New	Approved basic 15-105619 BP	2012 IRC	Plan# 4T06-B	3-story sfr w/attached gara	2015
New	Approved basic 15-106732 BP	2012 IRC	Plan# 4T07-B	3-story sfr w/attached g	2015
New	Approved basic 15-105618 BP	2012 IRC	Plan# 4T06-A	3-story sfr w/attached gara	2015
New	Approved basic 15-106731 BP	2012 IRC	Plan# 4T07-A	3-story sfr w/attached ga	2015
New	Approved basic 15-105619 BP	2012 IRC	Plan# 4T06-B	3-story sfr w/attached gara	2015
New	Approved basic 15-106732 BP	2012 IRC	Plan# 4T07-B	3-story sfr w/attached g	2015
New	Approved basic 15-105618 BP	2012 IRC	Plan# 4T06-A	3-story sfr w/attached gara	2015
New	Approved basic 15-106731 BP	2012 IRC	Plan# 4T07-A	3-story sfr w/attached ga	2015
New	Approved basic 15-105619 BP	2012 IRC	Plan# 4T06-B	3-story sfr w/attached gara	2015
New	Approved basic 15-106732 BP	2012 IRC	Plan# 4T07-B	3-story sfr w/attached g	2015
New	Approved basic 15-105618 BP	2012 IRC	Plan# 4T06-A	3-story sfr w/attached gara	2015

Accessory Dwelling Units

Index # - File Name: 1.0022 - Single Family Dwellings Data\_Snohomish County.pdf

New	Approved basic 15-106731 BP	2012 IRC	Plan# 4T07-A	3-story sfr w/attached garage	2015
New	Approved basic 15-105619 BP	2012 IRC	Plan# 4T06-B	3-story sfr w/attached garage	2015
New	Approved basic 15-106732 BP	2012 IRC	Plan# 4T07-B	3-story sfr w/attached garage	2015
New	Approved basic 15-105618 BP	2012 IRC	Plan# 4T06-A	3-story sfr w/attached garage	2015
New	Approved basic 13-110975 BP	2012 IRC	Plan: Flagstaff	Two-story SFR with 245 sq ft attached garage	2015
New	Demolish old shop & build new 2 story SFR with attached garage.			SEE: 15-104342-LDA, 1	2015
New	Approved basic 14-116069 BP	2012 IRC	Plan# 4332	2-story sfr w/attached garage	2015
New	Approved basic 14-116068 BP	2012 IRC	Plan# 4068	2-story sfr w/attached garage	2015
New	Approved basic 14-116069 BP	2012 IRC	Plan# 4332	2-story sfr w/attached garage	2015
New	Approved basic 14-116069 BP	2012 IRC	Plan# 4332	2-story sfr w/attached garage	2015
New	Approved basic 15-105462 BP	2012 IRC	Plan# 2646 A&B	2-story sfr w/attached garage	2015
New	Approved basic 15-105461 BP	IRC 2012	Plan# 2235 A&B	2-story sfr w/attached garage	2015
New	Approved basic 15-105463 BP	2012 IRC	Plan# 2776 A&B	2-story sfr w/attached garage	2015
New	Approved basic 15-105461 BP	IRC 2012	Plan# 2235 A&B	2-story sfr w/attached garage	2015
New	Approved basic 15-105463 BP	2012 IRC	Plan# 2776 A&B	2-story sfr w/attached garage	2015
New	Approved basic 15-105462 BP	2012 IRC	Plan# 2646 A&B	2-story sfr w/attached garage	2015
New	Approved basic 15-105463 BP	2012 IRC	Plan# 2776 A&B	2-story sfr w/attached garage	2015
New	Approved basic 15-105463 BP	2012 IRC	Plan# 2776 A&B	2-story sfr w/attached garage	2015
New	Approved basic 15-105462 BP	2012 IRC	Plan# 2646 A&B	2-story sfr w/attached garage	2015
New	Approved basic 15-105461 BP	IRC 2012	Plan# 2235 A&B	2-story sfr w/attached garage	2015
New	Approved basic 14-105272 BP	2012 IRC	Plan# 2140 A	2-story sfr w/attached garage	2015
New	Approved basic 14-101224 BP	2012 IRC	Plan# 2273 A & B Elevation	2-story sfr w/attached garage	2015
New	Approved basic 14-101224 BP	2012 IRC	Plan# 2273 A & B Elevation	2-story sfr w/attached garage	2015
New	2-story sfr w/attached garage				2015
New	2-story sfr w/attached garage				2015
New	2-story sfr w/attached garage				2015
New	2-story sfr w/attached garage				2015
New	Approved basic 14-113580 BP	2012 IRC	Plan# 2825-A	2-story sfr w/attached garage	2015
New	SFR: 2 story with attached garage, 4 bedrooms				2015
New	Approved basic 14-102337 BP	2012 IRC	Plan# 2728	2-story sfr w/attached garage	2015
New	2-story SFR with attached garage built in development area of a Forterra Conservation Easement				2015
New	SFR: rambler style home w/ attached 3 car garage, covered front and back porches, 3 bedrooms				2015
New	Approved basic 14-111054 BP	2012 IRC	Plan# Chelan Craftsman	2-story sfr w/attached garage	2015
New	New 2-story SFR with attached garage				2015
New	New 2 story SFR			SEE: 15-107586-LDA & 15-107585-AB	2015
New	2015 30 x 70 Westridge 1703CT				2015
New	New 2-story SFR with attached garage			SEE:15-108832-LDA	2015
New	New 2- story SFR with attached garage			SEE: 15-109137-LDA	2015
New	Approved basic 13-112612 BP	2012 IRC	Plan# 3315	2-story sfr w/attached garage	2015
New	2-story sfr w/attached garage				2015
New	1762 sq ft SFR with attached Garage				2015
New	Two story SFR with attached garage				2015
New	1,802 sf Rambler w/684 sf attached garage				2015
New	New rambler style SFR w/ attached garage				2015

Accessory Dwelling Units

Index # - File Name: 1.0022 - Single Family Dwellings Data\_Snohomish County.pdf

New	1679 sf rambler w/attached garage				2015
New	1,894 sf Rambler w/667 sf attached garage				2015
New	1,894 sf Rambler w/667 sf attached garage				2015
New	Approved basic 15-110262 BP	2012 IRC	Plan# 2820 A/B	2-story sfr w/attached gar	2015
New	Approved basic 15-110266 BP	2012 IRC	Plan# 2921 A/B	2-story sfr w/attached gar	2015
New	Approved basic 15-110265 BP	2012 IRC	Plan# 2820 A/B	2-story sfr w/attached gar	2015
New	Two story SFR with attached Garage				2015
New	Approved basic 15-110262 BP	2012 IRC	Plan# 2820 A/B	2-story sfr w/attached gar	2015
New	Approved basic 15-110262 BP	2012 IRC	Plan# 2820 A/B	2-story sfr w/attached gar	2015
New	Approved basic 13-114583 BP	2012 IRC	Plan# Kimball-A	2-story sfr w/attached g	2015
New	Approved basic 14-110820 BP	2012 IRC	Plan# Hazelwood B	2-story sfr w/attached g	2015
New	1,946 sf Rambler w/647 sf attached garage				2015
New	1638 s.f. rambler				2015
New	Approved basic 14-101008 BP	2012 IRC	Plan# 4035A	2-story sfr w/attached ga	2015
New	Approved basic 14-101009 BP	2012 IRC	Plan# 4035B	2-story sfr w/attached g	2015
New	Approved basic 14-101010 BP	2012 IRC	Plan# 4035C	2-story sfr w/attached ga	2015
New	Approved basic 14-101008 BP	2012 IRC	Plan# 4035A	2-story sfr w/attached ga	2015
New	Approved basic 14-101006 BP	2012 IRC	Plan# 4028B	2-story sfr w/attached gara	2015
New	Approved basic 13-106889 BP	2012 IRC	Plan# 461 A	2-story sfr w/attached garage	2015
New	Approved basic 14-110307 BP	2012 IRC	Plan# 456 AB	2-story sfr w/attached g	2015
New	Approved basic 15-111666 BP	2012 IRC	Plan# 473 B	2-story sfr w/attached garage	2015
New	Approved basic 13-108273 BP	2012 IRC	Plan#448 B	2-story sfr w/attached garage	2015
New	Approved basic 15-114733 BP	2012 IRC	Plan# 2418-02AB	3-story sfr w/atta	2015
New	Approved basic 14-111141 BP	2012	Plan# 2518-02AB	3-story sfr w/attached g	2015
New	Approved basic 14-111141 BP	2012	Plan# 2518-02AB	3-story sfr w/attached g	2015
New	Approved basic 14-111141 BP	2012	Plan# 2518-02AB	3-story sfr w/attached g	2015
New	Approved basic 15-114733 BP	2012 IRC	Plan# 2418-02AB	3-story sfr w/atta	2015
New	Approved basic 15-114733 BP	2012 IRC	Plan# 2418-02AB	3-story sfr w/atta	2015
New	Approved basic 15-114733 BP	2012 IRC	Plan# 2418-02AB	3-story sfr w/atta	2015
New	Approved basic 15-114733 BP	2012 IRC	Plan# 2418-02AB	3-story sfr w/atta	2015
New	Approved basic 15-114733 BP	2012 IRC	Plan# 2418-02AB	3-story sfr w/atta	2015
New	Approved basic 15-117547 BP	2012 IRC	Plan# 1720-02 AB	2-story sfr	2015
New	Approved basic 15-117547 BP	2012 IRC	Plan# 1720-02 AB	2-story sfr	2015
New	Approved basic 15-117547 BP	2012 IRC	Plan# 1720-02 AB	2-story sfr	2015
New	2-story sfr w/attached garage				2015
New	Rambler style sfr w/attached garage				2015
New	2-story sfr w/attached garage				2015
New	Approved basic 14-105508 BP	2012 IRC	Plan# Jupiter 2005	Rambler sfr w/att	2015
New	Approved basic 15-102227 BP	2012 IRC	Plan# 1292-duplex	2-story duplex	2015
New	Split entry single family residence with attached garage				2015
New	Approved basic 15-115804 BP	2012 IRC	Plan# 2925-38-9	2-story sfr w/day	2015
New	Approved basic 15-115805 BP	2012 IRC	Plan# 3033-38-9	2-story sfr w/dayligl	2015
New	Approved basic 15-115804 BP	2012 IRC	Plan# 2925-38-9	2-story sfr w/day	2015
New	Approved basic 15-115805 BP	2012 IRC	Plan# 3033-38-9	2-story sfr w/dayligl	2015
New	2 story sfr w/attached garage				2015
New	Approved basic 15-113350 BP	2012 IRC	Plan# 2054	2-story sfr w/attached gar	2015
New	Approved basic 15-113350 BP	2012 IRC	Plan# 2054	2-story sfr w/attached gar	2015



Accessory Dwelling Units

Index # - File Name: 1.0022 - Single Family Dwellings Data\_Snohomish County.pdf

New	Approved	basic 15-113350 BP	2012 IRC	Plan# 2054	2-story sfr w/attached gar	2015
New	Approved	basic 15-112606 BP	2012 IRC	Plan# 2311 B	2-story sfr w/attached garage	2015
New	Approved	basic 15-112606 BP	2012 IRC	Plan# 2311 B	2-story sfr w/attached garage	2015
New	Approved	basic 15-103241 BP	2012 IRC	Plan# 2137-A	2-story sfr w/attached gar	2015
New	Approved	basic 13-109681 BP	2012 IRC	Plan# Harlequin	2-story sfr w/attached	2015
New		2-story sfr NO garage				2015
New	Approved	basic 15-116170 BP	2012 IRC	Plan# The Maston	2-story sfr w/	2015
New	Approved	basic 15-112986 BP	2012 IRC	Plan# 2580-02 AB 2	2-story sfr w/attach	2015
New	Approved	basic 14-112821 BP	2012 IRC	Plan# Russell A	2-story sfr w/attached g	2015
New		SFR: two story style home with attached garage, 4 bedroom, 3.5 baths				2015
New		2 story sfr w/attached garage				2015
New		Rambler style sft w/attached garage				2015
New	Approved	basic 14-101010 BP	2012 IRC	Plan# 4035C	2-story sfr w/attached ga	2015
New	Approved	basic 14-101009 BP	2012 IRC	Plan# 4035B	2-story sfr w/attached g	2015
New	Approved	basic 14-101005 BP	2012 IRC	Plan# 4028A	2-story sfr w/attached ga	2015
New	Approved	basic 14-101006 BP	2012 IRC	Plan# 4028B	2-story sfr w/attached gara	2015
New	Approved	basic 14-101010 BP	2012 IRC	Plan# 4035C	2-story sfr w/attached ga	2015
New	Approved	basic 14-101007 BP	2012 IRC	Plan# 4028C	2-story sfr w/attached	2015
New	Approved	basic 14-101006 BP	2012 IRC	Plan# 4028B	2-story sfr w/attached gara	2015
New	Approved	basic 14-101008 BP	2012 IRC	Plan# 4035A	2-story sfr w/attached ga	2015
New		2 story sfr w/attached garage				2015
New	Approved	basic 14-108208 BP	2012 IRC	Plan# 2060 Rambler	Rambler style sfr w/atti	2015
New	Approved	basic 15-102319 BP	2012 IRC	Plan# 2225	Rambler style sfr w/attache	2015
New	Approved	basic 15-102321 BP	2012 IRC	Plan# 2439	Rambler style sfr w/attached	2015
New		2308 SF Rambler with Attached Garage				2015
New		Rambler style sfr w/attached garage and bonus above				2015
New		New 2,368 sf 2-story home with 672 sf garage and 192 sf patio.				2015
New		SFR: 2 story style home with covered front porch and attached 3 car garage. 4 bedroom/2.5 bat				2015
New		New single-family residence with attached garage; subject to Land Disturbing Activity permit un				2015
New	Approved	basic 15-111064 BP	2012 IRC	Plan# 33-30.02 T4 - Henley53	2-story sfr w	2015
New	Approved	basic 14-113065 BP	2012 IRC	Plan# 32-30.02 V - Henley36	2-story sfr w/	2015
New	Approved	basic 13-107612 BP	2012 IRC	Plan# Plan# 2457/2DB	2-story sfr w/attached	2015
New	Approved	basic 14-106989 BP	2012 IRC	Plan# 32-30.02 F2 - Henley29	2-story sfr \	2015
New	Approved	basic 14-100353 BP	2012 IRC	Plan# 32-30.02 A - Henley14	2-story sf	2015
New	Approved	basic 14-113065 BP	2012 IRC	Plan# 32-30.02 V - Henley36	2-story sfr w/	2015
New	Approved	basic 15-106293 BP	2012 IRC	Plan# 31-30.12 U8 - Henley47	2-story sfr w/	2015
New	Approved	basic 14-106989 BP	2012 IRC	Plan# 32-30.02 F2 - Henley29	2-story sfr \	2015
New	Approved	basic 13-107612 BP	2012 IRC	Plan# Plan# 2457/2DB	2-story sfr w/attached	2015
New	Approved	basic 15-105965 BP	2012 IRC	Plan# 38-30.12 S2 - Henley44	2-story sfr w	2015
New	Approved	basic 15-101619 BP	2012 IRC	Plan# 32-30.12 F2 - Henley42	2-story	2015
New	Approved	basic 14-113454 BP	2012 IRC	Plan# 32-30.02 J - Henley37	2-story sfr w/a	2015
New	Approved	basic 15-104520 BP	2012 IRC	Plan#39-30.02 T - Henley46	2-story sfr w/	2015
New	Approved	basic 14-101874.	2012 IRC.	Plan# 35-30.02 F - Henley.	2 story sfr w/ attache	2015
New	Approved	basic 13-107612 BP	2012 IRC	Plan# Plan# 2457/2DB	2-story sfr w/attached	2015
New	Approved	basic 14-113454 BP	2012 IRC	Plan# 32-30.02 J - Henley37	2-story sfr w/	2015
New	Approved	basic 15-101619 BP	2012 IRC	Plan# 32-30.12 F2 - Henley42	2-story	2015
New	Approved	Basic 13-108546 BP.	2012 IRC.	Plan # 33-30.02 V4.	2 story sfr w/ attache	2015

Accessory Dwelling Units

Index # - File Name: 1.0022 - Single Family Dwellings Data\_Snohomish County.pdf

New	Approved	basic 15-106098 BP	2012 IRC	Plan# 37-40.02 H - Henley46	2-story sfr w/	2015
New	Approved	basic 14-113065 BP	2012 IRC	Plan# 32-30.02 V - Henley36	2-story sfr w/	2015
New	Approved	basic 14-106989 BP	2012 IRC	Plan# 32-30.02 F2 - Henley29	2-story sfr w/	2015
New	Approved	basic 15-106293 BP	2012 IRC	Plan# 31-30.12 U8 - Henley47	2-story sfr w/	2015
New	Approved	basic 14-100353 BP	2012 IRC	Plan# 32-30.02 A - Henley14	2-story sfr	2015
New	Approved	basic 14-113065 BP	2012 IRC	Plan# 32-30.02 V - Henley36	2-story sfr w/	2015
New	Approved	basic 13-115906 BP	2012 IRC	Plan# 33-30.02 F - Henley14	2-story sfr w/	2015
New	Approved	basic 14-109259 BP	2012 IRC	Plan# 36-30.02 XC - Henley34	2-story sfr w/	2015
New	Approved	basic 14-102307 BP	2012 IRC	Plan# 35-30.02 H - Henley18	2-story sfr w/	2015
New	Approved	basic 15-113198 BP	2012 IRC	Plan# 2322	Rambler/attached garage	2015
New	Approved	basic 15-102321 BP	2012 IRC	Plan# 2439	Rambler style sfr w/attached	2015
New		2702 s.f. rambler w/attached garage				2015
New	Approved	basic 15-113200 BP	2012 IRC	Plan# 2573	Rambler/attached garage	2015
New		New 2-story SFR with attached garage				2015
New	Approved	basic 15-107214 BP	2012 IRC	Plan# 38-40.02 S - Henley48	2-story sfr	2015
New	Approved	basic 14-113065 BP	2012 IRC	Plan# 32-30.02 V - Henley36	2-story sfr w/	2015
New		New 2 story SFR with attached garage and new driveway				2015
New	Approved	basic 15-105560 BP	2012 IRC	Plan# 3224	2-story sfr w/attached garage	2015
New	Approved	basic 13-112361 BP	2012 IRC	Plan# West Point	2-story sfr w/attached garage	2015
New	Approved	basic 15-105560 BP	2012 IRC	Plan# 3224	2-story sfr w/attached garage	2015
New	Approved	basic 15-106946 BP	2012 IRC	Plan# 3602	2-story sfr w/attached garage	2015
New	Approved	basic 15-104014 BP	2012 IRC	Plan# 3591	SFR: rambler w/ finished dayligh	2015
New		Two Story SFR with Attached Garage				2015
New		Two Story SFR with Attached Garage				2015
New		2 story SFR with attached garage				2015
New	Approved	Basic 14-108165-BP	2012 IRC		New SFR w/ attached gar	2015
New	Approved	basic 15-104014 BP	2012 IRC	Plan# 3591	SFR: rambler w/ finished dayligh	2015
New	Approved	basic 15-101178 BP	2012 IRC	Plan# 3477	2-story sfr w/attached	2015
New	Approved	basic 14-101004 BP	2012 IRC	Plan# 3019C	2-story sfr w/attached gara	2015
New	Approved	basic 14-101000 BP	2012 IRC	Plan# 3014C	2-story sfr w/attached ga	2015
New	Approved	basic 14-101003 BP	2012 IRC	Plan# 3019A	2-story sfr w/attached ga	2015
New	Approved	basic 14-101005 BP	2012 IRC	Plan# 4028A	2-story sfr w/attached ga	2015
New	Approved	basic 14-101009 BP	2012 IRC	Plan# 4035B	2-story sfr w/attached g	2015
New	Approved	basic 14-101004 BP	2012 IRC	Plan# 3019C	2-story sfr w/attached gara	2015
New	Approved	basic 14-100999 BP	2012 IRC	Plan# 3014B	2-story sfr w/attached ga	2015
New	Approved	basic 14-101003 BP	2012 IRC	Plan# 3019A	2-story sfr w/attached ga	2015
New	Approved	basic 14-101005 BP	2012 IRC	Plan# 4028A	2-story sfr w/attached ga	2015
New	Approved	basic 14-101008 BP	2012 IRC	Plan# 4035A	2-story sfr w/attached ga	2015
New	Approved	basic 14-101007 BP	2012 IRC	Plan# 4028C	2-story sfr w/attached	2015
New	Approved	basic 14-101005 BP	2012 IRC	Plan# 4028A	2-story sfr w/attached ga	2015
New	Approved	basic 14-101009 BP	2012 IRC	Plan# 4035B	2-story sfr w/attached g	2015
New	Approved	basic 14-101007 BP	2012 IRC	Plan# 4028C	2-story sfr w/attached	2015
New	Approved	basic 14-101008 BP	2012 IRC	Plan# 4035A	2-story sfr w/attached ga	2015
New	Approved	basic 14-101006 BP	2012 IRC	Plan# 4028B	2-story sfr w/attached gara	2015
New	Approved	basic 14-101010 BP	2012 IRC	Plan# 4035C	2-story sfr w/attached ga	2015
New	Approved	basic 14-107536 BP	2012 IRC	Plan# 2720	2-story sfr w/attached gara	2015
New	Approved	basic 14-107536 BP	2012 IRC	Plan# 2720	2-story sfr w/attached gara	2015

Accessory Dwelling Units

Index # - File Name: 1.0022 - Single Family Dwellings Data\_Snohomish County.pdf

New	Approved	basic 14-107536 BP	2012 IRC	Plan# 2720	2-story sfr w/attached gara	2015
New	Approved	basic 14-107536 BP	2012 IRC	Plan# 2720	2-story sfr w/attached gara	2015
New	Approved	basic 14-102336 BP	2012 IRC	Plan# 3165	2-story sfr w/attached g	2015
New	Approved	basic 14-102087 BP	2012 IRC	Plan# 3313	2-story sfr w/attached gara	2015
New	Approved	basic 15-102741 BP	2012 IRC	Plan# 2278	2-story sfr w/attached }	2015
New	Approved	basic 13-114094 BP	2012 IRC	Plan# 2200	2-story sfr w/attached	2015
New	Approved	basic 14-105508 BP	2012 IRC	Plan# Jupiter 2005	Rambler sfr w/att	2015
New	Approved	basic 14-101357 BP	2012 IRC	Plan# 1866	Rambler style sfr w/attac	2015
New	Approved	basic 14-112963 BP	2012 IRC	Plan# 1704	Rambler style w/dayligh	2015
New	Approved	basic 14-112963 BP	2012 IRC	Plan# 1704	Rambler style w/dayligh	2015
New	Approved	basic 14-106849 BP	2012 IRC	Plan# 2254	2-story sfr w/attached gar	2015
New	Approved	basic 13-114094 BP	2012 IRC	Plan# 2200	2-story sfr w/attached	2015
New	Approved	basic 15-113460 BP	2012 IRC	Plan# 2537	2-story sfr w/attache	2015
New	Approved	basic 14-106849 BP	2012 IRC	Plan# 2254	2-story sfr w/attached gar	2015
New	Approved	basic 14-106849 BP	2012 IRC	Plan# 2254	2-story sfr w/attached gar	2015
New	Approved	Basic 14-101358 BP	2012 IRC	Plan# 2774	2-story sfr w/attache	2015
New		2254 sf sfr over garage with 330 sf finished daylight basement - 2012 IRC				2015
New		SFR, 2 story style home with attached 3 car garage with covered front entry, 4 bedroom/2.5 bat				2015
New	Approved	basic 14-102087 BP	2012 IRC	Plan# 3313	2-story sfr w/attached gara	2015
New	Permit changing basic plan to Approved	basic 14-107536 BP	2012 IRC	Plan# 2720		2015
New	Approved	basic 15- 102340 BP	2012 IRC	Plan# 2870-45-9	2-story sfr w/attache	2015
New	Approved	basic 14-102335 BP	2012 IRC	Plan# 3112	2-story sfr w/attached garage	2015
New	Approved	basic 14-102337 BP	2012 IRC	Plan# 2728	2-story sfr w/attached g	2015
New	Approved	basic 14-102337 BP	2012 IRC	Plan# 2728	2-story sfr w/attached g	2015
New	Approved	basic 15- 102340 BP	2012 IRC	Plan# 2870-45-9	2-story sfr w/attache	2015
New	Approved	basic 15- 102340 BP	2012 IRC	Plan# 2870-45-9	2-story sfr w/attache	2015
New	Approved	basic 14-107536 BP	2012 IRC	Plan# 2720	2-story sfr w/attached gara	2015
New	Approved	basic 14-102087 BP	2012 IRC	Plan# 3313	2-story sfr w/attached gara	2015
New	Approved	basic 13-108755 BP.	2012 IRC.	Plan # 3722-B.	2 story sfr w/ attached	2015
New	Approved	basic 13-108746 BP.	2012 IRC.	Plan # 3728-B.	2 story sfr w/ attached garage.	2015
New	Approved	basic 13-108754 BP.	2012 IRC.	Plan # 3722-A.	2 story sfr w/ attached gar	2015
New	Approved	basic 14-105089 BP	2012 IRC	Plan# 2800A&B/2	2-story sfr w/attached	2015
New	Approved	basic 14-105089 BP	2012 IRC	Plan# 2800A&B/2	2-story sfr w/attached	2015
New	Approved	basic 14-105089 BP	2012 IRC	Plan# 2800A&B/2	2-story sfr w/attached	2015
New	Approved	basic 15-112544 BP	2015 IRC	Plan# 2774	2-story sfr w/attached g	2015
New	Approved	basic 14-105089 BP	2012 IRC	Plan# 2800A&B/2	2-story sfr w/attached	2015
New	Approved	basic 14-105086 BP	2012 IRC	Plan# 2220A&B/2	2-story sfr w/attache	2015
New	Approved	basic 15-112544 BP	2015 IRC	Plan# 2774	2-story sfr w/attached ga	2015
New	Approved	basic 14-105086 BP	2012 IRC	Plan# 2220A&B/2	2-story sfr w/attache	2015
New	Approved	basic 14-105087 BP	2012 IRC	Plan# 2258A&B/2	2-story sfr w/attached }	2015
New	Approved	basic 14-105086 BP	2012 IRC	Plan# 2220A&B/2	2-story sfr w/attache	2015
New	Approved	basic 14-105087 BP	2012 IRC	Plan# 2258A&B/2	2-story sfr w/attached }	2015
New	Approved	basic 14-105086 BP	2012 IRC	Plan# 2220A&B/2	2-story sfr w/attache	2015
New	Approved	basic 14-105086 BP	2012 IRC	Plan# 2220A&B/2	2-story sfr w/attache	2015
New	Approved	basic 14-105086 BP	2012 IRC	Plan# 2220A&B/2	2-story sfr w/attache	2015
New	Approved	basic 14-105086 BP	2012 IRC	Plan# 2220A&B/2	2-story sfr w/attache	2015
New	Approved	basic 13-108690 BP	2012 IRC	Plan# 3733-B	2-story sfr w/attached gara	2015
New		2-story sfr w/attached garage				2015

Accessory Dwelling Units

Index # - File Name: 1.0022 - Single Family Dwellings Data\_Snohomish County.pdf

New	Approved basic 13-111068 BP	2012 IRC	Plan# B724-B	2-story sfr w/attached	2015
New	Approved basic 13-108687 BP.	2012 IRC.	Plan # 3729-B.	2 story sfr w/ attached	2015
New	Approved basic 13-111937BP	2012 IRC.	Plan #2311-B.	2 story sfr w/ attached garage.	2015
New	2169 s.f. rambler w/attached garage				2015
New	New two-story SFR with attached garage consisting of 2670 sf.				2015
New	Approved Basic 13-108750 BP.	2012 IRC.	Plan # 3705-A.	2 story sfr w/ attached	2015
New	Approved basic 13-108689 BP	2012 IRC	Plan#3733-A	2-story sfr w/attached gara	2015
New	Approved basic 13-108686BP	2012 IRC.	Plan # 3729 - A.	2 story sfr w/ attach	2015
New	Approved 13-112690 BP	2012 IRC	Plan# 4703-B	2-story sfr w/attached garage	2015
New	Approved basic 13-111073 BP	2012 IRC	Plan# B720-B	2-story sfr w/attached	2015
New	Approved basic 13-111068 BP	2012 IRC	Plan# B724-B	2-story sfr w/attached	2015
New	Approved basic 14-110881 BP	2012 IRC	Plan# Elm Bungalow	2-story sfr w/attache	2015
New	7/18/16ses- will give 30 days past expiration for Final Inspection	Approved basic 14-110884 BP			2015
New	Approved basic 14-110875 BP	2012 IRC	Plan# Maple Shingle	2-story sfr w/attache	2015
New	Approved basic 14-110882 BP	2012 IRC	Plan# Cherry Bungalow	2-story sfr w/a	2015
New	SFR: new Two Story home with attached 2 car garage, 4 bedroom, 2.5 bath	4/20/16 applicant c			2015
New	SFR: new Two story home with attached 2 car garage, 4 bedroom and 2.5 bath				2015
New	2 story w/finished basement & attached garage				2015
New	Approved basic 14-111055 BP	2012 IRC	Plan# Penrose Shingle/Traditional	3-	2015
New	2 story SFR w/basement & attached garage				2015
New	***New Plans: See Permit #16-109573 RK approved plans for ALL inspections performed after J				2015
New	2 story w/finished basement & attached garage				2015
New	Approved basic 14-111055 BP	2012 IRC	Plan# Penrose Shingle/Traditional	3-	2015
New	SFR: Two Story home with basement and attached 2 car garage, 3 bedroom				2015
New	Approved basic 14-111055 BP	2012 IRC	Plan# Penrose Shingle/Traditional	3-	2015
New	2,254 sf 2-story w/basement SFR w/419 sf garage				2015
New	Approved basic 14-111054 BP	2012 IRC	Plan# Chelan Craftsman	2-story sfr w,	2015
New	SFR: new Two Story home with attached 2 car garage, 4 bedroom, 2.5 bath				2015
New	SFR: new Two Story home with attached 2 car garage, 4 bedroom, 2.5 bath				2015
New	Two story SFR with attached garage				2015
New	Two story SFR with attached garage				2015
New	2 story sfr w/attached garage				2015
New	Two story SFR with attached Garage				2015
New	Approved basic 14-111053 BP	2012 IRC	Plan# Chelan Shingle	2-story sfr w/at	2015
New	Approved basic 14-111053 BP	2012 IRC	Plan# Chelan Shingle	2-story sfr w/at	2015
New	2 story sfr w/attached garage - REVISION TO 15-107072 RK Structural Plans - All inspections to l				2015
New	2,640 sf 2 story SFR w/ 532 sf garage				2015
New	Two story SFR with attached Garage				2015
New	2 Story sfr w/attached garage				2015
New	2 Story sfr w/attached garage				2015
New	2 Story sfr w/attached garage				2015
New	Approved basic 14-111054 BP	2012 IRC	Plan# Chelan Craftsman	2-story sfr w,	2015
New	2,640 sf 2 story SFR w/ 532 sf garage				2015
New	2,751sf 2 story SFR w/ 430sf garage				2015
New	2 story SFR w/attached garage				2015
New	Two story SFR with attached garage				2015
New	Rambler style sfr w/attached garage				2015

Accessory Dwelling Units

Index # - File Name: 1.0022 - Single Family Dwellings Data\_Snohomish County.pdf

New	New 2- story SFR with attached garage				2015
New	2375sq ft One Story SFR with 704sq ft Attached Garage and 240 sq ft Covered Porch/Deck				2015
New	Approved basic 13-110011 BP	2012 IRC	Plan# 3097	2-story sfr w/attached garage	2015
New	Approved basic 14-100799 BP	2012 IRC	Plan# 2191 A	2-story sfr w/attached garage	2015
New	Approved basic 14-100798 BP	2012 IRC	Plan# 2191 B	2-story sfr w/attached garage	2015
New	2 story w/finished basement and attached garage				2015
New	Approved basic 13-111194 BP	2012 IRC	Plan 3179 B	2-story sfr w/attached garage	2015
New	Approved basic 13-111198 BP	2012 IRC	Plan# 3069 B	2-story sfr w/attached garage	2015
New	Approved basic 13-111194 BP	2012 IRC	Plan 3179 B	2-story sfr w/attached garage	2015
New	Approved basic 13-111197 BP	2012 IRC	Plan# 3528 A	2-story sfr w/attached garage	2015
New	Approved basic 13-111196 BP	2012 IRC	Plan# 3097 B	2-story w/daylight basement	2015
New	Approved basic 13-110014 BP	2012 IRC	Plan# 2818 A	2-story sfr w/attached garage	2015
New	2-story sfr w/attached garage				2015
New	Approved basic 14-110875 BP	2012 IRC	Plan# Maple Shingle	2-story sfr w/attached garage	2015
New	Approved basic 14-110885 BP	2012 IRC	Plan# Cherry Shingle	2-story sfr w/attached garage	2015
New	Approved basic 14-110874 BP	2012 IRC	Plan# Maple Craftsman	2-story sfr w/attached garage	2015
New	Approved basic 14-110882 BP	2012 IRC	Plan# Cherry Bungalow	2-story sfr w/attached garage	2015
New	Approved basic 14-110876 BP	2012 IRC	Plan# Maple Bungalow	2-story sfr w/attached garage	2015
New	Approved basic 14-110885 BP	2012 IRC	Plan# Cherry Shingle	2-story sfr w/attached garage	2015
New	Approved basic 14-110879 BP	2012 IRC	Plan# Elm Craftsman	2-story sfr w/attached garage	2015
New	2 Story sfr w/attached garage				2015
New	2 story w/attached garage				2015
New	Approved basic 13-111199 BP	2012 IRC	Plan# 3069 A	2-story sfr w/attached garage	2015
New	Approved basic 14-110881 BP	2012 IRC	Plan# Elm Bungalow	2-story sfr w/attached garage	2015
New	Approved basic 14-110875 BP	2012 IRC	Plan# Maple Shingle	2-story sfr w/attached garage	2015
New	Approved basic 14-110875 BP	2012 IRC	Plan# Maple Shingle	2-story sfr w/attached garage	2015
New	Approved basic 14-110874 BP	2012 IRC	Plan# Maple Craftsman	2-story sfr w/attached garage	2015
New	Approved basic 14-110876 BP	2012 IRC	Plan# Maple Bungalow	2-story sfr w/attached garage	2015
New	Approved basic 13-111199 BP	2012 IRC	Plan# 3069 A	2-story sfr w/attached garage	2015
New	Approved basic 13-111194 BP	2012 IRC	Plan 3179 B	2-story sfr w/attached garage	2015
New	Approved basic 13-110011 BP	2012 IRC	Plan# 3097	2-story sfr w/attached garage	2015
New	Approved basic 13-111198 BP	2012 IRC	Plan# 3069 B	2-story sfr w/attached garage	2015
New	Approved basic 13-111194 BP	2012 IRC	Plan 3179 B	2-story sfr w/attached garage	2015
New	Approved basic 13-111196 BP	2012 IRC	Plan# 3097 B	2-story sfr w/attached garage	2015
New	Approved 13-110015 BP	2012 IRC	Plan# 3179 B	2-story sfr w/attached garage	2015
New	Approved basic 14-100798 BP	2012 IRC	Plan# 2191 B	2-story sfr w/attached garage	2015
New	Revision to issued permit 14-116393 rk changing to	Approved basic 14-100798 BP	2012 I		2015
New	Approved basic 13-110014 BP	2012 IRC	Plan# 2818 A	2-story sfr w/attached garage	2015
New	Approved basic 13-110011 BP	2012 IRC	Plan# 3097	2-story sfr w/attached garage	2015
New	Approved basic 13-110012 BP	2012 IRC	Plan# 2818 B	2-story sfr w/attached garage	2015
New	Approved basic 13-111196 BP	2012 IRC	Plan# 3097 B	2-story sfr w/attached garage	2015
New	Approved basic 14-100799 BP	2012 IRC	Plan# 2191 A	2-story sfr w/attached garage	2015
New	Approved basic 13-111194 BP	2012 IRC	Plan 3179 B	2-story sfr w/attached garage	2015
New	Approved Basic 13-110015-BP	2012 IBC		2 story SFR w/ attached garage	2015
New	This permit is to change the structural plans to this new	Approved basic 13-111197 BP	2012 I		2015
New	Approved basic 13-111939.	2012 IRC.	Plan #2573-A.	2 story sfr w/ attached garage	2015
New	New rambler SFR with attached garage				2015

Accessory Dwelling Units

Index # - File Name: 1.0022 - Single Family Dwellings Data\_Snohomish County.pdf

New	2364 sq ft SFR with attached Garage				2015
New	2223 rambler w/attached garage				2015
New	Revision to issued permit changing to Approved basic 13-114094 BP	2012 IRC		Pla	2015
New	Approved basic 15-103241 BP	2012 IRC	Plan# 2137-A	2-story sfr w/attached gar	2015
New	Approved basic 13-111937BP	2012 IRC.	Plan #2311-B.	2 story sfr w/ attached garage.	2015
New	Approved basic 13-111943.	2012 IRC.	Plan #3114-C.	3 story sfr w/ basement	2015
New	Approved basic 13-112895 BP.	2012 IRC.	Plan# 2845-B.	3 story sfr w/ attached garage.	2015
New	Approved basic 14-114966 BP	2012 IRC	Plan# 31-30.32 V - Henley38	2-story sfr w,	2015
New	Approved basic 14-109259 BP	2012 IRC	Plan# 36-30.02 XC - Henley34	2-story sfr w/i	2015
New	Approved basic 14-114967 BP	2012 IRC	Plan# 31-30.12 T - Henley38	2-story sfr w	2015
New	Approved basic 14-113069 BP	2012 IRC	Plan# 3-35.02 F - Henley36	2-story sfr w	2015
New	New 2- story SFR with attached garage			SEE:15-108569-LDA	2015
New	Elevation change to 2 story sfr w/attached garage.				2015
New	600 sq ft SFR wth 360 sq ft covered deck				2015
New	2101 s.f. rambler w/attached garage				2015
New	2-story sfr w/attached garage				2015
New	Approved basic 14-101081 BP	2012 IRC	Plan# 2688	2-story sfr w/attached	2015
New	Approved basic 14-101084 BP	2012 IRC	Plan# 2804	2-story sfr w/attached	2015
New	Approved basic 14-101078 BP	2012 IRC	Plan# 2441	2-story sfr w/attached	2015
New	Approved basic 14-101078 BP	2012 IRC	Plan# 2441	2-story sfr w/attached	2015
New	2-story sfr w/attached garage				2015
New	2 story sfr w/attached garage				2015
New	Approved basic 14-113884 BP	2012 IRC	Plan# 415 ABCD	2-story sfr w/attached gar	2015
New	800 SF SFR over 900 SF Garage with Bathroom				2015
New	2-story sfr w/attached garage				2015
New	2-story sfr w/attached garage				2015
New	Approved basic 13-112491.	IRC 2012.	Plan #2660.	2 story sfr w/ attached garag	2015
New	Approved basic 14-105376 BP	2012IRC	Plan# 456 AB	2-story sfr w/attached ga	2015
New	Approved basic 13-109292 BP	2012 IRC	Plan# 448 B	2-story sfr w/attached garage	2015
New	2 story sfr w/attached garage				2015
New	Approved basic 13-109291 BP	2012 IRC	Plan# 448 A	2-story sfr w/attached garage	2015
New	Approved basic 13-109708 BP	2012 IRC	Plan# 455 AB	2-story sfr w/attached gara	2015
New	Approved basic 13-109292 BP	2012 IRC	Plan# 448 B	2-story sfr w/attached garage	2015
New	Approved basic 13-109708 BP	2012 IRC	Plan# 455 AB	2-story sfr w/attached gara	2015
New	Approved basic 13-114786 BP.	2012 IRC.	Plan# 495 A, B, C.	2 story sfr w/ attached ga	2015
New	2 story sfr w/attached garage				2015
New	Approved basic 13-109708 BP	2012 IRC	Plan# 455 AB	2-story sfr w/attached gara	2015
New	Approved basic 14-105377 BP	2012 IRC	Plan# 556 AB	2-story sfr w/attached gara	2015
New	Approved basic 13-113537 BP.	2012 IRC.	Plan # 515 BC.	2 story sfr w/attached garage anc	2015
New	Approved basic 14-105377 BP	2012 IRC	Plan# 556 AB	2-story sfr w/attached gara	2015
New	Approved basic 14-105377 BP	2012 IRC	Plan# 556 AB	2-story sfr w/attached gara	2015
New	Approved basic 14-105377 BP	2012 IRC	Plan# 556 AB	2-story sfr w/attached gara	2015
New	Approved basic 13-112889 BP.	2012 IRC.	Plan # 2501-B.	2 story sfr w/ attached garage.	2015
New	Approved basic 13-111872.	2012 IRC.	Plan # 2873-C.	2 story sfr w/ attache	2015
New	Approved basic 14-109191BP.	2012 IRC.	Plan # 3183-C.	2 story sfr w/ attache	2015
New	Approved basic 14-114150BP	2012 IRC	Plan# Bailey A	2-story sfr w/attached garag	2015
New	Approved basic 14-114193 BP	2012 IRC	Plan# Bailey B	2-story sfr w/attached gar	2015

Accessory Dwelling Units

Index # - File Name: 1.0022 - Single Family Dwellings Data\_Snohomish County.pdf

New	Approved basic 13-111869.	2012 IRC.	Plan # 2873-A.	2 story sfr w/ attached gara	2015
New	Approved basic 14-109192 BP.	2012 IRC.	Plan # 3183-B.	2 story sfr w/ attache	2015
New	SFR: 2 story home with attached 3 car garage. Covered porch in front and outdoor covered livin				2015
New	Approved basic 13-111937BP	2012 IRC.	Plan #2311-B.	2 story sfr w/ attached garage.	2015
New	Approved basic 14-109189 BP.	2012 IRC.	Plan # 3181-A.	2 story sfr w/ attache	2015
New	3306 SF SFR with 900 SF Attached Garage and 742 SF Covered Patio and Porches				2015
New	4 Bedroom SFR, two-story with garage and covered porch				2015
New	2-story sfr no garage				2015
New	2-story sfr w/no garage				2015
New	SFR: rambler style home with attached 3 car garage, 3 bedrooms, 2.5 baths				2015
New	1996 27 x 52 Marlette 9501				2015
New	Approved basic 15-106945 BP	2012 IRC	Plan# 2974	2-story sfr w/attached gara	2015
New	Approved basic 15-114846 BP	2012 IRC	Plan# 2212	Rambler style sfr	2015
New	SFR: Rambler with attached 3 car garage, 3 bedrooms, 2.5 bath plus 20 x 20 covered back patio				2015
New	Approved basic 15-101179 BP	2012 IRC	Plan# 2807	2-story sfr w/attached g	2015
New	Approved Basic 14-113493.	2012 IRC.	Plan 3: Tamarack Plan A.	2 story sfr w/ attached ga	2015
New	Approved basic 15-101177 BP	2012 IRC	Plan# 3044	2-story sfr w/attached }	2015
New	Approved Basic 14-113494.	2012 IRC.	Plan: Tamarack B	2 story sfr w/ attached gara	2015
New	Approved basic 15-106942 BP	2012 IRC	Plan# 2766	Rambler sfr w/attached ga	2015
New	Manufactured Home: 2015, double wide, Mountain Ledge #2848A (26 x 56)				2015
New	SFR: rambler style home with attached 2 car garage, 3 bedrooms / 2.5 baths				2015
New	Rambler style sfr w/attached garage and bonus above				2015
New	2 story sfr w/ attached garage.				2015
New	850 sq ft detached accessory apartment				2015
New	SFR: rambler style with attached 2 car garage, 4 bedrooms and 3.5 bath				2016
New	Approved basic 14-107536 BP	2012 IRC	Plan# 2720	2-story sfr w/attached gara	2016
New	Approved basic 14-107536 BP	2012 IRC	Plan# 2720	2-story sfr w/attached gara	2016
New	Approved basic 14-107536 BP	2012 IRC	Plan# 2720	2-story sfr w/attached gara	2016
New	New 2,781 SF 2 story home with 680 sf garage and 260 sf of covered decks and porches				2016
New	New 2906 SF 2-story home with 643 sf garage, and 370 sf covered deck				2016
New	2-story SFR with attached garage				2016
New	Two Story SFR with Attached Garage				2016
New	New 3,099 SFR, 1-story w/basement, 642 sf garage, 96 sf covered porch and 204 sf deck				2016
New	New 3,099 SFR, 1-story w/basement, 642 sf garage, 96 sf covered porch and 204 sf deck				2016
New	New 3,366 2-story residence with 676 sf garage and 265 sf covered deck				2016
New	New 2-story SFR with attached garage			SEE:15-117055-LDA	2016
New	three bedroom rambler with attached garage				2016
New	Approved basic 16-108740 BP	2012 IRC	Plan# 3294	2-story sfr w/atta	2016
New	2158 s.f. rambler w/attached garge				2016
New	Approved basic 16-106750 BP	2012 IRC	Plan# 2688	2-story sfr w/atta	2016
New	New 1,684 sf rambler with 553 covered porch ***w/1,030 sf garage***				2016
New	Approved basic 15-106942 BP	2012 IRC	Plan# 2766	Rambler sfr w/attached ga	2016
New	Approved basic 16-108970 BP	2012 IRC	Plan# 2305-3 car	2-story sfr w	2016
New	Approved basic 15-106945 BP	2012 IRC	Plan# 2974	2-story sfr w/attached gara	2016
New	Two story SFR with attached Garage				2016
New	Approved basic 16-108381 BP	2012 IRC	Plan# 2550	2-story sfr w/att	2016
New	1534 square foot SFR with attached 472 square foot Garage				2016

Accessory Dwelling Units

Index # - File Name: 1.0022 - Single Family Dwellings Data\_Snohomish County.pdf

New	1534 square foot rambler with 472 square foot attached Garage				2016
New	4 BR 2-story SFR finished basement and attached garage, deck and covered porch				2016
New	2-story sfr w/attached garage				2016
New	Proposed detached accessory apt. with 354sq ft storage, 486 sq ft covered deck/porch, 1st floor				2016
New	New 1,649 sf 1-story SFR w/ 898 basement, 710 sf garage and 360 sf of covered deck/porch				2016
New	SFR: Rambler with daylight basement and attached 3 car garage				2016
New	1699 square foot SFR with 898 square foot finished basement and attached Garage				2016
New	Approved basic 16-103455 BP	2012 IRC	Plan# 2664	2-story sfr w/attach	2016
New	SFR: two story home with attached 3 car garage, 4 bedrooms, 2.5 baths and covered back patio				2016
New	New 2-story SFR with attached garage				2016
New	New 2- story SFR with attached garage				2016
New	New 2,441 sf 2-story SFR with 766 sf garage and 638 sf of covered deck/porch				2016
New	New 2,835 sf 2-story SFR with 769 sf garage and 522 sf of covered deck/porch				2016
New	New 2,662 sf 2-story SFR with 740 sf garage and 439 sf covered porch				2016
New	New 460 sf detached accessory apartment				2016
New	Approved basic 15-112606 BP	2012 IRC	Plan# 2311 B	2-story sfr w/attached garage	2016
New	Approved basic 15-112647 BP	2012 IRC	Plan# 2501 C	2-story sfr w/attached garage	2016
New	Approved basic 15-112606 BP	2012 IRC	Plan# 2311 B	2-story sfr w/attached garage	2016
New	Approved basic 15-112661 BP	2012 IRC	Plan# 3183 C	2-story sfr w/attached garage	2016
New	New 4 bedroom two-story SFR with attached garage -- 80 X 93 irregular shape.				2016
New	Approved basic 15-117488 BP	2012 IRC	Plan# 2873A	2-story sfr	2016
New	Approved basic 15-112646 BP	2012 IRC	Plan# 2501 B	2-story sfr w/attached garage	2016
New	Approved basic 15-112658 BP	2012 IRC	Plan# 3183 A	2-story sfr w/attached garage	2016
New	5022 square foot Duplex with 1426 square foot attached Garage				2016
New	Approved basic 15-103241 BP	2012 IRC	Plan# 2137-A	2-story sfr w/attached gar	2016
New	Approved basic 15-117490 BP	2012 IRC	Plan# 2873C	2-story sfr	2016
New	Approved basic 15-112606 BP	2012 IRC	Plan# 2311 B	2-story sfr w/attached garage	2016
New	Approved basic 15-103241 BP	2012 IRC	Plan# 2137-A	2-story sfr w/attached gar	2016
New	Approved basic 15-112658 BP	2012 IRC	Plan# 3183 A	2-story sfr w/attached garage	2016
New	Approved basic 15-117489 BP	2012 IRC	Plan# 2873B	2-story sfr	2016
New	Approved basic 15-112660 BP	2012 IRC	Plan# 3183 B	2-story sfr w/attached garage	2016
New	Approved basic 15-112647 BP	2012 IRC	Plan# 2501 C	2-story sfr w/attached garage	2016
New	Approved basic 15-117489 BP	2012 IRC	Plan# 2873B	2-story sfr	2016
New	Approved basic 15-112647 BP	2012 IRC	Plan# 2501 C	2-story sfr w/attached garage	2016
New	2 story sfr w/attached garage				2016
New	Approved basic 13-111199 BP	2012 IRC	Plan# 3069 A	2-story sfr w/attached gar	2016
New	Approved basic 15-108986 BP	2012 IRC	Plan# 2681 A	2-story sfr w/finished bas	2016
New	Approved basic 15-108984 BP	2012 IRC	Plan# 2681 B	2-story sfr w/finished bas	2016
New	New 2-story sfr w/attached garage				2016
New	New 2,153 SF 2-story SFR with 486 sf garage and 91 sf covered deck				2016
New	New 2,196 sf 2-story SFR with 436 sf garage and 61 sf covered deck				2016
New	Approved basic 14-110876 BP	2012 IRC	Plan# Maple Bungalow	2-story sfr w/attach	2016
New	Approved basic 14-100799 BP	2012 IRC	Plan# 2191 A	2-story sfr w/attached g	2016
New	New 2-story sfr w/attached garage				2016
New	SFR: 2 story with attached garage, 4 bedroom/2.5 bath				2016
New	2 story sfr with attached garage	2015 IRC			2016
New	Approved 13-110015 BP	2012 IRC	Plan# 3179 B	2-story sfr w/attached gara	2016



Accessory Dwelling Units

Index # - File Name: 1.0022 - Single Family Dwellings Data\_Snohomish County.pdf

New	Approved basic 15-108986 BP	2012 IRC	Plan# 2681 A	2-story sfr w/finished bas	2016
New	2-story sfr w/daylight basement w/attached garage				2016
New	Approved basic 13-111196 BP	2012 IRC	Plan# 3097 B	2-story sfr w/attached ga	2016
New	2338 s.f. single family residence w/900 s.f. unheated second floor storage & attached garage				2016
New	2 story home with attached 2 car garage, 4 bedrooms/2.5 baths				2016
New	Two Story SFR with attached Garage				2016
New	New 2,214 sf 2-story SFR with 403 sf garage and 68 sf covered porch				2016
New	Two story SFR with attached Garage				2016
New	2 story sfr w/attached garage				2016
New	Approved basic 15-112544 BP	2015 IRC	Plan# 2774	2-story sfr w/attached ga	2016
New	2 story sfr w/attached garage				2016
New	Approved basic 15-112544 BP	2015 IRC	Plan# 2774	2-story sfr w/attached ga	2016
New	Approved basic 14-105089 BP	2012 IRC	Plan# 2800A&B/2	2-story sfr w/attached	2016
New	Approved basic 15-112544 BP	2015 IRC	Plan# 2774	2-story sfr w/attached ga	2016
New	Approved basic 14-105089 BP	2012 IRC	Plan# 2800A&B/2	2-story sfr w/attached	2016
New	Approved basic 14-105089 BP	2012 IRC	Plan# 2800A&B/2	2-story sfr w/attached	2016
New	Approved basic 14-105089 BP	2012 IRC	Plan# 2800A&B/2	2-story sfr w/attached	2016
New	Approved basic 15-112544 BP	2015 IRC	Plan# 2774	2-story sfr w/attached ga	2016
New	Approved basic 14-105089 BP	2012 IRC	Plan# 2800A&B/2	2-story sfr w/attached	2016
New	Approved basic 14-105089 BP	2012 IRC	Plan# 2800A&B/2	2-story sfr w/attached	2016
New	Approved basic 14-105089 BP	2012 IRC	Plan# 2800A&B/2	2-story sfr w/attached	2016
New	Approved basic 14-107790	2012 IRC.	Plan # 2915	1 story sfr w/ daylight basement	2016
New	Approved basic 16-108740 BP	2012 IRC	Plan# 3294	2-story sfr w/atta	2016
New	Approved basic 16-108383 BP	2012 IRC	Plan# 3065	2-story sfr w/att	2016
New	Approved basic 16-108383 BP	2012 IRC	Plan# 3065	2-story sfr w/att	2016
New	Approved basic 16-108383 BP	2012 IRC	Plan# 3065	2-story sfr w/att	2016
New	New 2,295 sf sfr with 1,763 sf unfinished basement, 642 sf garage and 415 sf covered porch				2016
New	Two Story SFR with Attached Garage and 353 sqft Unfinished Basement				2016
New	Rambler with attached garage and covered porch				2016
New	New rambler style SFR with attached garage			SEE: 15-106174-LDA	2016
New	1868 square foot SFR with 758 attached Garage				2016
New	Approved basic 14-111816 BP	2012 IRC	Plan# Cascade II	2-story sfr w/attached ga	2016
New	Approved basic 14-112833 BP	2012 IRC	Plan# Augusta B	2-story sfr w/attache	2016
New	Approved basic 13-107227 BP	2012 IRC	Plan# Chelan II-A	2-story sfr w/attached gar	2016
New	New 2,874 sf home with 818 sf garage, 508 sf covered porch, 128 sf deck, and 580 sf of storage				2016
New	Approved basic 16-112046 BP	2015 IRC	Plan# 2580 AB 2015	2-story w/	2016
New	Approved basic 16-113546 BP	2015 IRC	Plan# 2501 DE 2015	2-story w/a	2016
New	Approved basic 16-113546 BP	2015 IRC	Plan# 2501 DE 2015	2-story w/a	2016
New	Approved basic 16-113546 BP	2015 IRC	Plan# 2501 DE 2015	2-story w/a	2016
New	Approved basic 16-112046 BP	2015 IRC	Plan# 2580 AB 2015	2-story w,	2016
New	Approved basic 16-113546 BP	2015 IRC	Plan# 2501 DE 2015	2-story w/a	2016
New	Two story SFR with attached Garage				2016
New	Two story SFR with attached Garage				2016
New	New 2,632 sf 2-story SFR with 510 sf garage and 161 sf covered porch				2016
New	Two story SFR with attached Garage				2016
New	1638 s.f. rambler				2016
New	3,545 sf 2-story house with 820 sf garage and 228 sf of covered porches and decks				2016
New	2 story w/158 s.f. finished basement and attached garage Engineered by Keith A Ryan, P.E. 408'				2016

Accessory Dwelling Units

Index # - File Name: 1.0022 - Single Family Dwellings Data\_Snohomish County.pdf

New	2 story w/158 s.f. finished basement and attached garage					2016
New	2 story w/158 s.f. finished basement and attached garage					2016
New	2 story w/158 s.f. finished basement and attached garage				RSP approved 3/11/17	2016
New	Approved basic 15-112606 BP	2012 IRC	Plan# 2311 B	2-story sfr w/attached garage		2016
New	Approved basic 15-103241 BP	2012 IRC	Plan# 2137-A	2-story sfr w/attached ga		2016
New	Approved basic 15-112645 BP	2012 IRC	Plan# 2501 A	2-story sfr w/attached garage		2016
New	Approved basic 15-118680 BP	2012 IRC	Plan# 1836A	2-story w/attache		2016
New	Approved basic 15-103241 BP	2012 IRC	Plan# 2137-A	2-story sfr w/attached ga		2016
New	Approved basic 15-118535 BP	2012 IRC	Plan# 2494B	2-story w/attached		2016
New	Approved basic 15-112606 BP	2012 IRC	Plan# 2311 B	2-story sfr w/attached garage		2016
New	Approved basic 15-118535 BP	2012 IRC	Plan# 2494B	2-story w/attached		2016
New	Approved basic 15-103241 BP	2012 IRC	Plan# 2137-A	2-story sfr w/attached ga		2016
New	Approved basic 15-118680 BP	2012 IRC	Plan# 1836A	2-story sfr w/attached gara		2016
New	Approved basic 15-112646 BP	2012 IRC	Plan# 2501 B	2-story sfr w/attached garage		2016
New	Approved basic 15-112645 BP	2012 IRC	Plan# 2501 A	2-story sfr w/attached garage		2016
New	Approved basic 15-103241 BP	2012 IRC	Plan# 2137-A	2-story sfr w/attached ga		2016
New	New 2,817 sf 2-story SFR with 605 sf of garage and 264 sf covered porch					2016
New	New 2-story SFR w/ attached garage					2016
New	2-story sfr w/daylight basement and attached garage					2016
New	Approved basic 16-105839 BP	2012 IRC	Plan# 2588-03AB	Rambler w/atta		2016
New	Approved basic 16-117500 BP	2015 IRC	Plan# 3134-03AB	2-story sfr w/		2016
New	Approved basic 16-103177 BP	2012 IRC	Plan# 3588-03AB	2-story sfr w/attache		2016
New	Approved basic 16-108894 BP	2012 IRC	Plan# 3304-03AB	2-story sfr w/atta		2016
New	Approved basic 16-114341 BP	2015 IRC	Plan# 3770-03AB	2-story sfr w/attached		2016
New	Approved basic 16-107335 BP	2012 IRC	Plan# 3648-03AB-DL	Rambler w/a		2016
New	Approved basic 15-101177 BP	2012 IRC	Plan# 3044	2-story sfr w/attached g		2016
New	Approved basic 16-100053 BP	2012 IRC	Plan# 3516 A	2-story sfr w/atta		2016
New	Approved basic 15-106942 BP	2012 IRC	Plan# 2766	Rambler sfr w/attached ga		2016
New	Approved basic 16-118221 BP	2015 IRC	Plan# 3392 A	2 story w/finished		2016
New	Approved basic 16-118640 BP	2015 IRC	Plan# 3392 B	2 story w/finished		2016
New	Approved basic 15-118691 BP	2012 IRC	Plan# Pratt 2000	2-story sfr w/a		2016
New	Approved basic 15-118691 BP	2012 IRC	Plan# Pratt 2000	2-story sfr w/a		2016
New	Approved basic 14-110800 BP	2012 IRC	Plan# 2034 Concord	2-story sfr w/attached		2016
New	Approved basic 15-118691 BP	2012 IRC	Plan# Pratt 2000	2-story sfr w/a		2016
New	Approved basic 15-118706 BP	2012 IRC	Plan# Madras 1948	2-story sfr w/a		2016
New	Approved basic 14-110800 BP	2012 IRC	Plan# 2034 Concord	2-story sfr w/attached		2016
New	Approved basic 15-118691 BP	2012 IRC	Plan# Pratt 2000	2-story sfr w/a		2016
New	Approved basic 15-118691 BP	2012 IRC	Plan# Pratt 2000	2-story sfr w/a		2016
New	Approved basic 15-118706 BP	2012 IRC	Plan# Madras 1948	2-story sfr w/a		2016
New	Approved basic 14-110800 BP	2012 IRC	Plan# 2034 Concord	2-story sfr w/attached		2016
New	Approved basic 15-118691 BP	2012 IRC	Plan# Pratt 2000	2-story sfr w/a		2016
New	Approved basic 15-118706 BP	2012 IRC	Plan# Madras 1948	2-story sfr w/at		2016
New	Approved basic 15-118691 BP	2012 IRC	Plan# Pratt 2000	2-story sfr w/a		2016
New	approved . basic 15-118691 BP	2012 IRC	Plan# Pratt 2000	2-story sfr w/i		2016
New	Approved basic 15-118706 BP	2012 IRC	Plan# Madras 1948	2-story sfr w/a		2016
New	Approved basic 15-118691 BP	2012 IRC	Plan# Pratt 2000	2-story sfr w/a		2016
New	Approved basic 15-118706 BP	2012 IRC	Plan# Madras 1948	2-story sfr w/a		2016

Accessory Dwelling Units

Index # - File Name: 1.0022 - Single Family Dwellings Data\_Snohomish County.pdf

New	Approved	basic 15-118691 BP	2012 IRC	Plan# Pratt 2000	2-story sfr w/a	2016
New	Approved	basic 15-118691 BP	2012 IRC	Plan# Pratt 2000	2-story sfr w/a	2016
New	Approved	basic 15-118706 BP	2012 IRC	Plan# Madras 1948	2-story sfr w/a	2016
New	Approved	basic 16-101485 BP	2012 IRC	Plan# 2082AM	2-story w/attache	2016
New	Approved	basic 15-119882 BP	2012 IRC	Plan# 2202	2-story w/attache	2016
New	Approved	basic 15-119882 BP	2012 IRC	Plan# 2202	2-story w/attache	2016
New	Approved	basic 15-119882 BP	2012 IRC	Plan# 2202	2-story w/attache	2016
New	Approved	basic 15-119883 BP	2012 IRC	Plan# 2003	2-story w/attache	2016
New	Approved	basic 15-118224 BP	2012 IRC	Plan# 2244	2-story sfr w/attached garage	2016
New	Approved	basic 15-118223 BP	2012 IRC	Plan # 2202	2 story sfr w/ attached garag	2016
New	Approved	basic 15-118221 BP	2012 IRC	Plan# 2162	2-story sfr w/attached gara	2016
New	Approved	basic 15-118223 BP	2012 IRC	Plan # 2202	2 story sfr w/ attached garag	2016
New	Approved	basic 15-118221 BP	2012 IRC	Plan# 2162	2-story sfr w/attached gara	2016
New	Approved	basic 15-118223 BP	2012 IRC	Plan # 2202	2 story sfr w/ attached garag	2016
New	Approved	basic 15-118224 BP	2012 IRC	Plan# 2244	2-story sfr w/attached garage	2016
New	Approved	basic 15-118224 BP	2012 IRC	Plan# 2244	2-story sfr w/attached garage	2016
New	Approved	basic 15-118224 BP	2012 IRC	Plan# 2244	2-story sfr w/attached garage	2016
New	Approved	basic 15-118224 BP	2012 IRC	Plan# 2244	2-story sfr w/attached garage	2016
New	Approved	basic 15-118221 BP	2012 IRC	Plan# 2162	2-story sfr w/attached gara	2016
New	Approved	basic 15-118221 BP	2012 IRC	Plan# 2162	2-story sfr w/attached gara	2016
New	Approved	basic 15-118223 BP	2012 IRC	Plan # 2202	2 story sfr w/ attached garag	2016
New	Approved	basic 15-118219 BP	2012 IRC	Plan #2074	2 story sfr w/ attai	2016
New	Approved	basic 15-118224 BP	2012 IRC	Plan# 2244	2-story sfr w/attached garage	2016
New	Approved	basic 15-118224 BP	2012 IRC	Plan# 2244	2-story sfr w/attached garage	2016
New	Approved	basic 15-118223 BP	2012 IRC	Plan # 2202	2 story sfr w/ attached garag	2016
New	Approved	basic 15-118220 BP	2012 IRC	Plan #1924	2 story sfr w/ attached	2016
New	Approved	basic 15-118223 BP	2012 IRC	Plan # 2202	2 story sfr w/ attached garag	2016
New	Approved	basic 15-118221 BP	2012 IRC	Plan# 2162	2-story sfr w/attached gara	2016
New	Approved	basic 15-118223 BP	2012 IRC	Plan # 2202	2 story sfr w/ attached garag	2016
New	Approved	basic 15-118223 BP	2012 IRC	Plan # 2202	2 story sfr w/ attached garag	2016
New	Approved	basic 15-118223 BP	2012 IRC	Plan # 2202	2 story sfr w/ attached garag	2016
New	Approved	basic 15-118221 BP	2012 IRC	Plan# 2162	2-story sfr w/attached gara	2016
New	Approved	basic 15-118223 BP	2012 IRC	Plan # 2202	2 story sfr w/ attached garag	2016
New	Approved	basic 15-118221 BP	2012 IRC	Plan# 2162	2-story sfr w/attached gara	2016
New	Approved	basic 15-118223 BP	2012 IRC	Plan # 2202	2 story sfr w/ attached garag	2016
New	Approved	basic 15-118221 BP	2012 IRC	Plan# 2162	2-story sfr w/attached gara	2016
New	Approved	basic 15-118223 BP	2012 IRC	Plan # 2202	2 story sfr w/ attached garag	2016
New	Approved	basic 15-118221 BP	2012 IRC	Plan# 2162	2-story sfr w/attached gara	2016
New	Approved	basic 15-118223 BP	2012 IRC	Plan # 2202	2 story sfr w/ attached garag	2016
New	Approved	basic 15-102332 BP	2012 IRC	Plan# Rainier C	2-story sfr w/attached gara	2016
New	Approved	basic 13-114583 BP	2012 IRC	Plan# Kimball-A	2-story sfr w/attached g	2016
New	Approved	basic 15-117473 BP	2012 IRC	Plan# Trafton C	2-story sfr w/attached	2016
New	Approved	basic 13-114756 BP	2012 IRC	Plan# Rainier-B	2-story sfr w/attached	2016
New	Approved	basic 15-118990 BP	2012 IRC	Plan# Kimball - B	2-story sfr w/attached	2016
New	Approved	basic 15-102332 BP	2012 IRC	Plan# Rainier C	2-story sfr w/attached gara	2016
New	Approved	basic 16-100166 BP	2012 IRC	Plan# Cavanaugh C/D	2-story sfr w/at	2016
New	Approved	basic 15-117474 BP	2012 IRC	Plan# Trafton D	2-story sfr w/attached g	2016
New	Approved	basic 15-117473 BP	2012 IRC	Plan# Trafton C	2-story sfr w/attached	2016
New	Approved	basic 13-111588 BP	2012 IRC	Plan# Kitsap-B	2-story sfr w/attached ga	2016

Accessory Dwelling Units

Index # - File Name: 1.0022 - Single Family Dwellings Data\_Snohomish County.pdf

New	Approved basic 15-118990 BP	2012 IRC	Plan# Kimball - B	2-story sfr w/attached	2016
New	Approved basic 15-117474 BP	2012 IRC	Plan# Trafton D	2-story sfr w/attached ga	2016
New	Approved basic 15-102332 BP	2012 IRC	Plan# Rainier C	2-story sfr w/attached gara	2016
New	Approved basic 16-100166 BP	2012 IRC	Plan# Cavanaugh C/D	2-story sfr w/at	2016
New	Approved basic 15-102333 BP	2012 IRC	Plan# Rainer D	2-story sfr w/attached g	2016
New	Approved basic 15-107151 BP	2012 IRC	Plan# Dayton C	2-story sfr w/attached ga	2016
New	Approved basic 16-100166 BP	2012 IRC	Plan# Cavanaugh C/D	2-story sfr w/at	2016
New	26 X 48 Mobile Home for Temporary Dwelling				2016
New	2-story sfr w/finished basement & attached garage				2016
New	2-story sfr w/finished basement & attached garage				2016
New	Single story SFR with attached garage and unfinished basement.				2016
New	New 2-story, 2,632 square foot SFR with 510 SF attached garage, and 154 SF covered porch	Eng			2016
New	Two story SFR with attached Garage				2016
New	2 story sfr w/attached garage				2016
New	2 story SFR and attached garage				2016
New	Two story SFR with attached Garage				2016
New	2 story SFR and attached garage				2016
New	2 story SFR with finished basement and attached garage				2016
New	New 2-story 2,404 square foot SFR with attached 497 SF garage and 273 SF covered deck.				2016
New	Approved basic 14-110318 BP	2012 IRC	Plan#2131 Rambler	Rambler style	2016
New	Approved basic 15-113460 BP	2012 IRC	Plan# 2537	2-story sfr w/attache	2016
New	Approved basic 16-100935 BP	2012 IRC	Plan# 2060 (38# snow)	2-story sfr w/at	2016
New	Approved basic 14-110318 BP	2012 IRC	Plan#2131 Rambler	Rambler style	2016
New	Approved basic 14-112963 BP	2012 IRC	Plan# 1704	Rambler style w/dayligh	2016
New	Approved basic 16-100935 BP	2012 IRC	Plan# 2060 (38# snow)	2-story sfr w/at	2016
New	Approved basic 14-106849 BP	2012 IRC	Plan# 2254	2-story sfr w/attached gar	2016
New	Approved basic 13-101858 BP	2009 IRC	Plan# 2200	2-story sfr w/attached }	2016
New	Approved basic 15-113460 BP	2012 IRC	Plan# 2537	2-story sfr w/attache	2016
New	Approved basic 16-100935 BP	2012 IRC	Plan# 2060 (38# snow)	2-story sfr w/at	2016
New	Approved basic 14-106849 BP	2012 IRC	Plan# 2254	2-story sfr w/attached gar	2016
New	Approved basic 16-100774 BP	2012 IRC	Plan# 2200 (38# snow)	2-story sfr w/a	2016
New	Approved basic 16-100775 BP	2012 IRC	Plan# 2254 (38# snow)	2-story sfr w/a	2016
New	Approved basic 16-100774 BP	2012 IRC	Plan# 2200 (38# snow)	2-story sfr w/a	2016
New	Approved basic 16100778- BP	2012 IRC	Plan# 2541 (38# snow)	2-story sfr w/a	2016
New	Approved basic 16-100935 BP	2012 IRC	Plan# 2060 (38# snow)	2-story sfr w/at	2016
New	Approved basic 16-100775 BP	2012 IRC	Plan# 2254 (38# snow)	2-story sfr w/a	2016
New	Approved basic 16-100935 BP	2012 IRC	Plan# 2060 (38# snow)	2-story sfr w/at	2016
New	Approved basic 16-100775 BP	2012 IRC	Plan# 2254 (38# snow)	2-story sfr w/a	2016
New	Approved basic 16100778- BP	2012 IRC	Plan# 2541 (38# snow)	2-story sfr w/a	2016
New	Approved basic 16-100935 BP	2012 IRC	Plan# 2060 (38# snow)	2-story sfr w/at	2016
New	Approved basic 16100778- BP	2012 IRC	Plan# 2541 (38# snow)	2-story sfr w/a	2016
New	Approved basic 16-100775 BP	2012 IRC	Plan# 2254 (38# snow)	2-story sfr w/a	2016
New	Approved basic 16-100774 BP	2012 IRC	Plan# 2200 (38# snow)	2-story sfr w/a	2016
New	Approved basic 16-100935 BP	2012 IRC	Plan# 2060 (38# snow)	2-story sfr w/att	2016
New	Approved basic 16100778- BP	2012 IRC	Plan# 2541 (38# snow)	2-story sfr w/a	2016
New	Approved basic 16-100935 BP	2012 IRC	Plan# 2060 (38# snow)	2-story sfr w/at	2016
New	Approved basic 16-100774 BP	2012 IRC	Plan# 2200 (38# snow)	2-story sfr w/a	2016

Accessory Dwelling Units

Index # - File Name: 1.0022 - Single Family Dwellings Data\_Snohomish County.pdf

New	Approved basic 16-100775 BP	2012 IRC	Plan# 2254 (38# snow)	2-story sfr w/a	2016
New	Approved basic 16-100774 BP	2012 IRC	Plan# 2200 (38# snow)	2-story sfr w/a	2016
New	Approved basic 16100778- BP	2012 IRC	Plan# 2541 (38# snow)	2-story sfr w/a	2016
New	Approved basic 16-100774 BP	2012 IRC	Plan# 2200 (38# snow)	2-story sfr w/a	2016
New	Approved basic 16-100775 BP	2012 IRC	Plan# 2254 (38# snow)	2-story sfr w/a	2016
New	Approved basic 16-107394 BP	2012 IRC	Plan# 1704 38#	Rambler style w/d	2016
New	Approved basic 15-112646 BP	2012 IRC	Plan# 2501 B	2-story sfr w/attached garage	2016
New	Approved basic 15-112606 BP	2012 IRC	Plan# 2311 B	2-story sfr w/attached garage	2016
New	Approved basic 15-103241 BP	2012 IRC	Plan# 2137-A	2-story sfr w/attached gar	2016
New	Approved basic 15-112606 BP	2012 IRC	Plan# 2311 B	2-story sfr w/attached garage	2016
New	Approved basic 15-103241 BP	2012 IRC	Plan# 2137-A	2-story sfr w/attached gar	2016
New	Approved basic 15-118535 BP	2012 IRC	Plan# 2494B	2-story w/attached	2016
New	Approved basic 15-103241 BP	2012 IRC	Plan# 2137-A	2-story sfr w/attached gar	2016
New	Approved basic 15-118520 BP	2012 IRC	Plan# 2494A	2-story w/attache	2016
New	Approved basic 15-118535 BP	2012 IRC	Plan# 2494B	2-story w/attached	2016
New	Approved basic 15-118680 BP	2012 IRC	Plan# 1836A	2-story w/attache	2016
New	Approved basic 15-103241 BP	2012 IRC	Plan# 2137-A	2-story sfr w/attached gar	2016
New	Approved basic 15-112606 BP	2012 IRC	Plan# 2311 B	2-story sfr w/attached garage	2016
New	Approved basic 15-103241 BP	2012 IRC	Plan# 2137-A	2-story sfr w/attached gar	2016
New	Approved basic 15-112606 BP	2012 IRC	Plan# 2311 B	2-story sfr w/attached garage	2016
New	Approved basic 15-118535 BP	2012 IRC	Plan# 2494B	2-story w/attached	2016
New	Approved basic 15-112606 BP	2012 IRC	Plan# 2311 B	2-story sfr w/attached garage	2016
New	Approved basic 15-103241 BP	2012 IRC	Plan# 2137-A	2-story sfr w/attached gar	2016
New	Approved basic 15-112606 BP	2012 IRC	Plan# 2311 B	2-story sfr w/attached garage	2016
New	Approved basic 15-118520 BP	2012 IRC	Plan# 2494A	2-story w/attached	2016
New	Approved basic 15-112606 BP	2012 IRC	Plan# 2311 B	2-story sfr w/attached garage	2016
New	Approved basic 15-112645 BP	2012 IRC	Plan# 2501 A	2-story sfr w/attached garage	2016
New	Approved basic 15-112647 BP	2012 IRC	Plan# 2501 C	2-story sfr w/attached garage	2016
New	Approved basic 15-103241 BP	2012 IRC	Plan# 2137-A	2-story sfr w/attached gar	2016
New	Approved basic 13-114842.	2012 IRC.	Plan # 2190-A.	2 story sfr w/ attache	2016
New	5,534 sf 2 story home w/1,245 sf garage and 567 sf covered deck				2016
New	New 2,066 sf barn with 848 sf accessory apartment above and 354 sf covered porch				2016
New	Approved basic 16-100935 BP	2012 IRC	Plan# 2060 (38# snow)	2-story sfr w/att	2016
New	Approved basic 16-100775 BP	2012 IRC	Plan# 2254 (38# snow)	2-story sfr w/a	2016
New	Approved basic 16-100775 BP	2012 IRC	Plan# 2254 (38# snow)	2-story sfr w/a	2016
New	Approved basic 16-100775 BP	2012 IRC	Plan# 2254 (38# snow)	2-story sfr w/a	2016
New	Approved basic 16-100774 BP	2012 IRC	Plan# 2200 (38# snow)	2-story sfr w/a	2016
New	Approved basic 16-100775 BP	2012 IRC	Plan# 2254 (38# snow)	2-story sfr w/a	2016
New	Approved basic 16-100775 BP	2012 IRC	Plan# 2254 (38# snow)	2-story sfr w/a	2016
New	Approved basic 16-100774 BP	2012 IRC	Plan# 2200 (38# snow)	2-story sfr w/a	2016
New	Approved basic 16-100935 BP	2012 IRC	Plan# 2060 (38# snow)	2-story sfr w/att	2016
New	Approved basic 16-100775 BP	2012 IRC	Plan# 2254 (38# snow)	2-story sfr w/a	2016
New	Approved basic 16-107394 BP	2012 IRC	Plan# Plan# 1704 38#	sfr w/finished ba	2016
New	Approved basic 16-100775 BP	2012 IRC	Plan# 2254 (38# snow)	2-story sfr w/a	2016
New	Approved basic 16-100774 BP	2012 IRC	Plan# 2200 (38# snow)	2-story sfr w/a	2016
New	three bedroom/two-story SFR with attached garage, storage over garage with covered front anc				2016
New	New 2 story duplex in SFDU				2016

Accessory Dwelling Units

Index # - File Name: 1.0022 - Single Family Dwellings Data\_Snohomish County.pdf

New	Approved basic 14-111774 BP	2012 IRC	Plan# 3301-03ABC-25ft	2-story sfr w/at	2016
New	Approved basic 14-111774 BP	2012 IRC	Plan# 3301-03ABC-25ft	2-story sfr w/at	2016
New	Approved basic 14-111774 BP	2012 IRC	Plan# 3301-03ABC-25ft	2-story sfr w/at	2016
New	Approved basic 14-111773 BP	2012 IRC	Plan# 2763-03AB	2-story sfr w/attached g	2016
New	Approved basic 13-114672 BP	2012 IRC	Plan# 3310-03AB	2-story sfr w/attach	2016
New	3066 s.f. sfr w/572 s.f. bonus room and attached garage				2016
New	Approved basic 14-110370 BP	2012 IRC	Plan# 2261-38-9	2-story sfr w/att	2016
New	2-story sfr w/daylight basement w/attached garage				2016
New	Approved basic 15-119343 BP	2012 IRC	Plan# 1942-02AB	2-story w/attache	2016
New	Approved basic 15-119343 BP	2012 IRC	Plan# 1942-02AB	2-story w/attache	2016
New	Approved basic 15-119343 BP	2012 IRC	Plan# 1942-02AB	2-story w/attache	2016
New	Approved basic 15-119343 BP	2012 IRC	Plan# 1942-02AB	2-story w/attache	2016
New	Approved basic 15-119343 BP	2012 IRC	Plan# 1942-02AB	2-story w/attache	2016
New	Approved basic 16-102216 BP	2012 IRC	Plan# 2419-02 Dplx	3-story duplex w/atta	2016
New	Approved basic 16-102216 BP	2012 IRC	Plan# 2419-02 Dplx	3-story duplex w/atta	2016
New	Approved basic 15-114733 BP	2012 IRC	Plan# 2418-02AB	3-story sfr w/atta	2016
New	Approved basic 15-114733 BP	2012 IRC	Plan# 2418-02AB	3-story sfr w/atta	2016
New	Approved basic 14-110307 BP	2012 IRC	Plan# 456 AB	2-story sfr w/attached g	2016
New	Approved basic 13-110032 BP.	2012 IRC.	Plan # 471 AB.	2 story sfr w/ attached garage.	2016
New	Approved basic 13-108274 BP	2012 IRC	Plan# 461 B	2-story sfr w/attached garage	2016
New	Approved basic 14-112298 BP	2012 IRC	Plan# 417 ABCD	2-story sfr w/attach	2016
New	Approved basic 13-108273 BP	2012 IRC	Plan#448 B	2-story sfr w/attached garage	2016
New	Approved basic 14-110307 BP	2012 IRC	Plan# 456 AB	2-story sfr w/attached g	2016
New	Syklone-Westridge 2017 MH				2016
New	Approved basic 15-112547 BP	2012 IRC	Plan# 2100 B	2-story sfr w/attached garage	2016
New	Approved basic 15-111151 BP	2012 IRC	Plan# Stuart	2-story sfr w/attached gar	2016
New	Approved basic 15-109447 BP	2012 IRC	Plan# Whitman B	2-story sfr w/attached	2016
New	Approved basic 15-112991 BP	2012 IRC	Plan# Shuksan D	2-story sfr w/attached g	2016
New	Approved basic 15-111151 BP	2012 IRC	Plan# Stuart	2-story sfr w/attached gar	2016
New	Approved basic 15-109447 BP	2012 IRC	Plan# Whitman B	2-story sfr w/attached	2016
New	Approved basic 15-118990 BP	2012 IRC	Plan# Kimball - B	2-story sfr w/attached	2016
New	Approved basic 13-111588 BP	2012 IRC	Plan# Kitsap-B	2-story sfr w/attached ga	2016
New	Approved basic 14-100516 BP	2012 IRC	Plan# Dayton-B	2-story sfr w/attached g	2016
New	Approved basic 14-110820 BP	2012 IRC	Plan# Hazelwood B	2-story sfr w/attached g	2016
New	Approved basic 13-111589 BP	2012 IRC	Plan# Kitsap-A	2-story sfr w/attached g	2016
New	Approved basic 13-114582 BP	2012 IRC	Plan# Rainier-A	2-story sfr w/attached g	2016
New	Approved basic 13-111588 BP	2012 IRC	Plan# Kitsap-B	2-story sfr w/attached ga	2016
New	Approved basic 13-114756 BP	2012 IRC	Plan# Rainier-B	2-story sfr w/attached g	2016
New	Approved basic 13-114582 BP	2012 IRC	Plan# Rainier-A	2-story sfr w/attached g	2016
New	Approved basic 13-111589 BP	2012 IRC	Plan# Kitsap-A	2-story sfr w/attached g	2016
New	1724 s.f. rambler w/attached garage				2016
New	New 1,661 sf rambler with 462 sf garage and 100 sf of covered porch.				2016
New	1601 s.f. rambler w/attached garage				2016
New	New 1,679 sf rambler with 644 sf garage and 150 sf of covered porch.				2016
New	3 BR rambler with attached garage and covered porch				2016
New	1724 s.f. rambler w/attached garage				2016
New	1728 s.f. rambler w/attached garage				2016

Accessory Dwelling Units

Index # - File Name: 1.0022 - Single Family Dwellings Data\_Snohomish County.pdf

New	2 story sfr w/attached garage					2016
New	2 story sfr w/attached garage					2016
New	2 story sfr w/attached garage					2016
New	Approved basic 13-101858 BP	2009 IRC	Plan# 2200	2-story sfr w/attached g		2016
New	Approved basic 14-106849 BP	2012 IRC	Plan# 2254	2-story sfr w/attached gar		2016
New	Approved basic 15-114846 BP	2012 IRC	Plan# 2212	Rambler style sfr		2016
New	Approved basic 15-106945 BP	2012 IRC	Plan# 2974	2-story sfr w/attached gara		2016
New	Approved basic 15-114846 BP	2012 IRC	Plan# 2212	Rambler style sfr		2016
New	Approved basic 15-106945 BP	2012 IRC	Plan# 2974	2-story sfr w/attached gara		2016
New	Approved basic 15-106942 BP	2012 IRC	Plan# 2766	Rambler sfr w/attached ga		2016
New	Approved basic 15-106945 BP	2012 IRC	Plan# 2974	2-story sfr w/attached gara		2016
New	Approved basic 15-101179 BP	2012 IRC	Plan# 2807	2-story sfr w/attached gi		2016
New	Approved basic 16-106750 BP	2012 IRC	Plan# 2688	2-story sfr w/atta		2016
New	Approved basic 16-108381 BP	2012 IRC	Plan# 2550	2-story sfr w/atta		2016
New	2270 Single story SFR with attached garage					2016
New	New 3,114 sf 2-story SFR with 776 sf garage and 400 sf covered porch					2016
New	New rambler style SFR with attached garage					2016
New	New 2,735 sf rambler with 776 sf garage and 300 sf covered deck					2016
New	New 1,024 sf detached garage with 1,024 heated gameroom above					2016
New	New 2,270 sf rambler with 726 sf garage and 336 sf covered deck					2016
New	New 1,868 sf rambler with 765 sf garage and 220 covered deck					2016
New	Two story SFR with attached Garage					2016
New	Two story SFR with attached Garage					2016
New	Proposed 2,758 sf 2-story SFR with 532 sf garage, 83 sf covered porch, and 81 sf deck					2016
New	New 2,841 SF SFR with 430 SF attached garage and 149 SF covered deck.					2016
New	Two story SFR with attached Garage					2016
New	Two story SFR with attached Garage					2016
New	New 2-story SFR, 2,779 sf with 532 sf garage and 83 sf covered deck					2016
New	Two story SFR with attached Garage					2016
New	Two story SFR with attached Garage					2016
New	Two story SFR with attached Garage					2016
New	2-story sfr w/attached garage					2016
New	New SFR with attached accessory apartment: 4,035 sf of living space with 858 sf garage and 45 :					2016
New	Approved basic 14-116069 BP	2012 IRC	Plan# 4332	2-story sfr w/attached garage		2016
New	Approved basic 14-112279 BP	2012 IRC	Plan# 3445	Rambler style sfr w/attach		2016
New	Approved basic 14-112281 BP	2012 IRC	Plan# 2949	Rambler style sfr w/attached		2016
New	Approved basic 14-112282 BP	2012 IRC	Plan# 3201	Rambler style sfr w/attache		2016
New	Approved basic 14-107536 BP	2012 IRC	Plan# 2720	2-story sfr w/attached gara		2016
New	Approved basic 15-117501 BP	2012 IRC	Plan# 2825C	2-story sfr		2016
New	Approved basic 15-112547 BP	2012 IRC	Plan# 2100 B	2-story sfr w/attached garage		2016
New	New 3420 sf SFR with 930 sf garage and 432 sf covered porch					2016
New	Approved basic 15-112548 BP	2012 IRC	Plan# 2100 A	2-story sfr w/attached garage		2016
New	New 2-story SFR w/attached garage					2016
New	2-story sfr w/attached garage					2016
New	New 2-story 2190 sf residence with 465 sf garage and 52 sf covered porch					2016
New	SFR: two story style home with attached garage and covered back porch, 3 bedrooms 2.5 bath					2016
New	New 2-story SFR, 2,188 sf with 436 sf garage and 82 sf covered porch					2016

Accessory Dwelling Units

Index # - File Name: 1.0022 - Single Family Dwellings Data\_Snohomish County.pdf

New	New 2-story SFR, 2,196 sf with 436 sf garage and 61 sf covered porch	2016
New	Two story SFR with attached Garage	2016
New	New 2,153 sf 2-story sfr with 486 sf garage and 91 sf covered porch	2016
New	New 2,188 sf 2-story SFR with 436 sf garage and 82 sf covered deck	2016
New	New 2,153 sf 2-story SFR w/ 486 sf garage and 90 sf covered porch	2016
New	New 2,196 sf 2-story sfr with 436 sf garage and 61 sf covered porch	2016
New	New 2,188 sf 2-story residence with 82 sf covered porch and 436 sf garage	2016
New	New 2,153 sf 2-story SFR with 91 sf covered porch and 486 sf garage	2016
New	2 story sfr w/attached garage	2016
New	4 BR 2 story SFR with attached garage and covered proch	2016
New	New 2-story 2,190 sf SFR with 465 sf garage and 52 sf covered deck	2016
New	New 2- story SFR w/ attached garage	2016
New	New 2- story SFR w/ attached garage	2016
New	New 2,153 sf 2-story SFR with 486 sf garage and 91 sf covered deck	2016
New	New 2,188 sf 2-story SFR with 436 sf garage and 82 sf covered deck	2016
New	New 2-story 2,190 sf SFR with 465 sf garage and 52 sf covered deck	2016
New	New 2-story SFR, 2,204 SF with 465 sf garage and 55 sf covered deck	2016
New	New 2-story 2,190 sf SFR with 465 sf garage and 52 sf covered deck	2016
New	Withdrawn by applicant - New permit 16-106018 RK - Approved basic 14-110881 BP 2012 IR	2016
New	SFR: two story style home with attached garage	2016
New	SFR: two story style home with attached garage	2016
New	New 2,188 SF SFR with 436 SF attached garage and 82 SF covered deck.	2016
New	Approved basic 15-105463 BP 2012 IRC Plan# 2776 A&B 2-story sfr w/attached g	2016
New	Approved basic 15-105462 BP 2012 IRC Plan# 2646 A&B 2-story sfr w/attache	2016
New	Approved basic 15-105463 BP 2012 IRC Plan# 2776 A&B 2-story sfr w/attached g	2016
New	Approved basic 15-105462 BP 2012 IRC Plan# 2646 A&B 2-story sfr w/attache	2016
New	Approved basic 15-105462 BP 2012 IRC Plan# 2646 A&B 2-story sfr w/attache	2016
New	Approved basic 15-105463 BP 2012 IRC Plan# 2776 A&B 2-story sfr w/attached g	2016
New	Approved basic 15-105462 BP 2012 IRC Plan# 2646 A&B 2-story sfr w/attache	2016
New	Approved basic 15-105463 BP 2012 IRC Plan# 2776 A&B 2-story sfr w/attached g	2016
New	Approved basic 15-105462 BP 2012 IRC Plan# 2646 A&B 2-story sfr w/attache	2016
New	Approved basic 15-105463 BP 2012 IRC Plan# 2776 A&B 2-story sfr w/attached g	2016
New	Approved basic 15-105462 BP 2012 IRC Plan# 2646 A&B 2-story sfr w/attache	2016
New	Approved basic 15-105463 BP 2012 IRC Plan# 2776 A&B 2-story sfr w/attached g	2016
New	Approved basic 15-105462 BP 2012 IRC Plan# 2646 A&B 2-story sfr w/attache	2016
New	2- story SFR with attached garage SEE: 15-106369-LDA	2016
New	New 2-story SFR with attached 2 car garage and 46 sf covered porch, 4 bedroom/2.5 bath	2016
New	Two story SFR with attached Garage	2016
New	Two story SFR with attached Garage	2016
New	New 2- story SFR w/ attached garage	2016
New	New 2,153 sf 2-story SFR with 486 sf garage and 91 sf covered porch	2016
New	Two Story SFR with attached Garage	2016
New	SFR: two story style home with attached garage and covered back porch, 3 bedrooms 2.5 bath	2016
New	Two Story SFR with attached Garage	2016
New	SFR: two story style home with attached garage and covered back porch, 3 bedrooms 2.5 bath	2016
New	New 2,188 sf 2-story SFR with 436 sf garage and 82 sf covered porch	2016
New	SFR: two story style home with attached garage and covered back porch, 3 bedrooms 2.5 bath	2016
New	2405 s.f. sfr w/daylight basement (600 s.f. living space & 1475 s.f. storage) w/attached garage	2016



Accessory Dwelling Units

Index # - File Name: 1.0022 - Single Family Dwellings Data\_Snohomish County.pdf

New	Approved	basic 15-105618 BP	2012 IRC	Plan# 4T06-A	3-story sfr w/attached gara	2016
New	Approved	basic 15-106732 BP	2012 IRC	Plan# 4T07-B	3-story sfr w/attached g	2016
New	Approved	basic 15-105619 BP	2012 IRC	Plan# 4T06-B	3-story sfr w/attached gara	2016
New	Approved	basic 15-106731 BP	2012 IRC	Plan# 4T07-A	3-story sfr w/attached ga	2016
New		2 story sfr w/attached garage				2016
New	Approved	basic 14-108660 BP	2012 IRC	Plan# 3915-B	2-story sfr w/attached gara	2016
New	Approved	basic 15-103225 BP	2012 IRC	Plan# 3814	2-story sfr w/attached garage	2016
New	Approved	basic 15-103225 BP	2012 IRC	Plan# 3814	2-story sfr w/attached garage	2016
New	Approved	basic 13-108745 BP.	2012 IRC.	Plan # 3815-A.	2 story sfr w/ attache	2016
New	Approved	basic 15-103225 BP	2012 IRC	Plan# 3814	2-story sfr w/attached garage	2016
New	Approved	basic 14-113401 BP	2012 IRC	Plan# 3017C	2-story sfr w/attach	2016
New	Approved	basic 14-108597 BP	2012 IRC	Plan# 2440	2-story sfr w/attached g	2016
New	Approved	basic 14-108594 BP	2012 IRC	Plan# 2604	2-story sfr w/attached	2016
New	Approved	basic 14-108590 BP	2014 IRC	Plan# 2750	2-story sfr w/attached gara	2016
New	Approved	basic 14-108592 BP	2012 IRC	Plan# 2850	2-story sfr w/attache	2016
New	Approved	basic 14-108596 BP	2012 IRC	Plan# 2540	2-story sfr w/attache	2016
New	Approved	basic 14-108591 BP	2012 IRC	Plan# 3234	2-story sfr w/attached g	2016
New	Approved	basic 14-108591 BP	2012 IRC	Plan# 3234	2-story sfr w/attached g	2016
New	Approved	basic 14-114536 BP	2012 IRC	Plan# 2169	2-story sfr w/attached gara	2016
New	Approved	basic 14-108592 BP	2012 IRC	Plan# 2850	2-story sfr w/attache	2016
New	Approved	basic 15-103522 BP	2012 IRC	Plan# 3040	2-story sfr w/attached gara	2016
New	Approved	basic 14-108592 BP	2012 IRC	Plan# 2850	2-story sfr w/attache	2016
New	Approved	basic 14-108592 BP	2012 IRC	Plan# 2850	2-story sfr w/attache	2016
New	Approved	basic 14-108596 BP	2012 IRC	Plan# 2540	2-story sfr w/attache	2016
New	Approved	basic 14-108592 BP	2012 IRC	Plan# 2850	2-story sfr w/attache	2016
New	Approved	basic 14-108597 BP	2012 IRC	Plan# 2440	2-story sfr w/attached g	2016
New	Approved	basic 15-103522 BP	2012 IRC	Plan# 3040	2-story sfr w/attached gara	2016
New	Approved	basic 14-108592 BP	2012 IRC	Plan# 2850	2-story sfr w/attache	2016
New	Approved	basic 14-108590 BP	2014 IRC	Plan# 2750	2-story sfr w/attached gara	2016
New	Approved	basic 14-108594 BP	2012 IRC	Plan# 2604	2-story sfr w/attached	2016
New	Approved	basic 14-108597 BP	2012 IRC	Plan# 2440	2-story sfr w/attached g	2016
New	Approved	basic 14-108597 BP	2012 IRC	Plan# 2440	2-story sfr w/attached g	2016
New	Approved	basic 14-108596 BP	2012 IRC	Plan# 2540	2-story sfr w/attache	2016
New	Approved	basic 14-108594 BP	2012 IRC	Plan# 2604	2-story sfr w/attached	2016
New	Approved	basic 14-108596 BP	2012 IRC	Plan# 2540	2-story sfr w/attache	2016
New	Approved	basic 15-102257 BP	2012 IRC	Plan# 1433	2-story sfr w/attached ga	2016
New	Approved	basic 15-114847 BP	2012 IRC	Plan# 3484	2-story sfr w/atta	2016
New	Approved	basic 16-102477 BP	2012 IRC	Plan# 2096	Rambler style sfr w/a	2016
New	Approved	basic 16-106675 BP	2012 IRC	Plan# 3376	2-story sfr w/	2016
New	Approved	basic 14-112454 BP	2012 IRC	Plan# 2453	Rambler style sfr w/atta	2016
New	Approved	basic 14-112459 BP	2012 IRC	Plan# 2268	Rambler style sfr w/attach	2016
New	Approved	basic 16-106675 BP	2012 IRC	Plan# 3376	2-story sfr w/a	2016
New	Approved	basic 14-112459 BP	2012 IRC	Plan# 2268	Rambler style sfr w/attach	2016
New	Approved	basic 14-112457 BP	2012 IRC	Plan# 2309	2-story sfr w/attache	2016
New	Approved	basic 14-112461 BP	2012 IRC	Plan# 2653	2-story sfr w/attache	2016
New	Approved	basic 16-102477 BP	2012 IRC	Plan# 2096	Rambler style sfr w/a	2016
New	Approved	basic 14-112461 BP	2012 IRC	Plan# 2653	2-story sfr w/attache	2016

Accessory Dwelling Units

Index # - File Name: 1.0022 - Single Family Dwellings Data\_Snohomish County.pdf

New	Approved	basic 14-112454 BP	2012 IRC	Plan# 2453	Rambler style sfr w/attach	2016
New	Approved	basic 16-106675 BP	2012 IRC	Plan# 3376	2-story sfr w/i	2016
New	Approved	basic 14-112454 BP	2012 IRC	Plan# 2453	Rambler style sfr w/attach	2016
New	Approved	basic 14-112454 BP	2012 IRC	Plan# 2453	Rambler style sfr w/attach	2016
New	Approved	basic 14-112461 BP	2012 IRC	Plan# 2653	2-story sfr w/attache	2016
New	Approved	basic 14-112454 BP	2012 IRC	Plan# 2453	Rambler style sfr w/attach	2016
New	Approved	basic 14-112461 BP	2012 IRC	Plan# 2653	2-story sfr w/attache	2016
New	Approved	basic 14-112461 BP	2012 IRC	Plan# 2653	2-story sfr w/attache	2016
New	Approved	basic 16-100053 BP	2012 IRC	Plan# 3516 A	2-story sfr w/atta	2016
New	Approved	basic 14-112457 BP	2012 IRC	Plan# 2309	2-story sfr w/attache	2016
New	Approved	basic 14-112459 BP	2012 IRC	Plan# 2268	Rambler style sfr w/attach	2016
New	Approved	basic 14-112454 BP	2012 IRC	Plan# 2453	Rambler style sfr w/attach	2016
New	Approved	basic 14-112461 BP	2012 IRC	Plan# 2653	2-story sfr w/attache	2016
New	Approved	basic 14-112459 BP	2012 IRC	Plan# 2268	Rambler style sfr w/attach	2016
New	Approved	basic 14-112454 BP	2012 IRC	Plan# 2453	Rambler style sfr w/attach	2016
New	SFR: two story style home with covered front and back porch/patio, 4 bedrooms, 2.5 baths					2016
New	two story 4 BR SFR with attached garage					2016
New	two story 4 BD SFR with attached garage					2016
New	Two story SFR with attached Garage					2016
New	SFR over Garage					2016
New	Approved	basic 14-109116 BP	2012 IRC	Plan# 2440 B	2-story sfr w/attached garag	2016
New	**1/10/2019 LRR Expired without County approval to use or occupy**					2016
New	Approved basic 16-100					2016
New	New 3515 2-story home with 761 sf garage and 671 covered deck					2016
New	New 3515 2-story home with 761 sf garage and 671 covered deck					2016
New	Approved	basic 14-101224 BP	2012 IRC	Plan# 2273 A & B Elevation	2-story sfr w/a	2016
New	Approved	basic 15-117067 BP	2012 IRC	Plan# 2400 AB Plan	2-story sfr	2016
New	Approved	basic 15-117067 BP	2012 IRC	Plan# 2400 AB Plan	2-story sfr	2016
New	Approved	basic 15-117727 BP	2012 IRC	Plan# 2140 C WO	2-story sfr w/finished base	2016
New	Approved	basic 15-117725 BP	2012 IRC	Plan# 2140 B WO	2-story sfr w/finished base	2016
New	Approved	basic 15-117724 BP	2012 IRC	Plan# 2140 A WO	2-story sfr w/finished base	2016
New	2-story sfr w/finished basement & attached garage					2016
New	2-story sfr w/finished basement & attached garage					2016
New	2-story sfr w/finished basement & attached garage					2016
New	2-story sfr w/finished basement & attached garage					2016
New	Approved	basic 15-117067 BP	2012 IRC	Plan# 2400 AB Plan	2-story sfr	2016
New	Approved	basic 15-105619 BP	2012 IRC	Plan# 4T06-B	3-story sfr w/attached gara	2016
New	Approved	basic 15-106731 BP	2012 IRC	Plan# 4T07-A	3-story sfr w/attached ga	2016
New	Approved	basic 15-105618 BP	2012 IRC	Plan# 4T06-A	3-story sfr w/attached gara	2016
New	Approved	basic 15-106732 BP	2012 IRC	Plan# 4T07-B	3-story sfr w/attached g	2016
New	Approved	basic 15-112645 BP	2012 IRC	Plan# 2501 A	2-story sfr w/attached garage	2016
New	Approved	basic 14-105181 BP	2012 IRC	Plan# 2472 B	2-story sfr w/attached garage	2016
New	Approved	basic 14-105179 BP	2012 IRC	Plan# 2472 A	2-story sfr w/attached garage	2016
New	Approved	basic 14-105181 BP	2012 IRC	Plan# 2472 B	2-story sfr w/attached garage	2016
New	Approved	basic 14-101224 BP	2012 IRC	Plan# 2273 A & B Elevation	2-story sfr w/a	2016
New	Approved	basic 14-114993 BP	2012 IRC	Plan# 2600 A 12IRC	2-story sfr w/attache	2016
New	Approved	basic 14-105275 BP	2012 IRC	Plan# 2140 B	2-story sfr w/attached garag	2016
New	Approved	basic 15-112548 BP	2012 IRC	Plan# 2100 A	2-story sfr w/attached garage	2016

Accessory Dwelling Units

Index # - File Name: 1.0022 - Single Family Dwellings Data\_Snohomish County.pdf

New	Approved	basic 14-101224 BP	2012 IRC	Plan# 2273 A & B Elevation	2-story sfr w/a	2016
New	Approved	basic 14-101224 BP	2012 IRC	Plan# 2273 A & B Elevation	2-story sfr w/a	2016
New	Approved	basic 14-105179 BP	2012 IRC	Plan# 2472 A	2-story sfr w/attached garage	2016
New	Approved	basic 14-101224 BP	2012 IRC	Plan# 2273 A & B Elevation	2-story sfr w/a	2016
New	Approved	basic 14-105179 BP	2012 IRC	Plan# 2472 A	2-story sfr w/attached garage	2016
New	Approved	basic 14-105181 BP	2012 IRC	Plan# 2472 B	2-story sfr w/attached garage	2016
New	Approved	basic 15-112548 BP	2012 IRC	Plan# 2100 A	2-story sfr w/attached garage	2016
New	Approved	basic 15-112548 BP	2012 IRC	Plan# 2100 A	2-story sfr w/attached garage	2016
New	Approved	basic 14-101224 BP	2012 IRC	Plan# 2273 A & B Elevation	2-story sfr w/a	2016
New	Approved	basic 14-101224 BP	2012 IRC	Plan# 2273 A & B Elevation	2-story sfr w/a	2016
New	Approved	basic 15-112548 BP	2012 IRC	Plan# 2100 A	2-story sfr w/attached garage	2016
New	Approved	basic 14-101224 BP	2012 IRC	Plan# 2273 A & B Elevation	2-story sfr w/a	2016
New	Approved	basic 15-112547 BP	2012 IRC	Plan# 2100 B	2-story sfr w/attached garage	2016
New	Approved	basic 15-112548 BP	2012 IRC	Plan# 2100 A	2-story sfr w/attached garage	2016
New	Approved	basic 14-101224 BP	2012 IRC	Plan# 2273 A & B Elevation	2-story sfr w/a	2016
New	Approved	basic 14-105179 BP	2012 IRC	Plan# 2472 A	2-story sfr w/attached garage	2016
New	Approved	basic 15-114622 BP	2012 IRC	Plan# 2100 A WO	2-story sfr w/ba	2016
New	Approved	basic 14-101224 BP	2012 IRC	Plan# 2273 A & B Elevation	2-story sfr w/a	2016
New	Approved	basic 15-112548 BP	2012 IRC	Plan# 2100 A	2-story sfr w/attached garage	2016
New	Approved	basic 15-112547 BP	2012 IRC	Plan# 2100 B	2-story sfr w/attached garage	2016
New	Approved	basic 14-101224 BP	2012 IRC	Plan# 2273 A & B Elevation	2-story sfr w/a	2016
New	Approved	basic 14-101224 BP	2012 IRC	Plan# 2273 A & B Elevation	2-story sfr w/a	2016
New	New 1,885 sf residence w/410 sf garage, 24 sf covered porch, and 60 sf deck					2016
New	Approved	basic 13-107217 BP	2012 IRC	Plan# Franklin-B	2-story sfr w/attached garage	2016
New	Approved	basic 15-109997 BP	2012 IRC	Plan# Pilchuck C/D	2-story sfr w/attached	2016
New	Approved	basic 15-109339 BP	2012 IRC	Plan# Langley II A	2-story sfr w/attache	2016
New	Approved	basic 15-106946 BP	2012 IRC	Plan# 3602	2-story sfr w/attached gara	2016
New	2999 s.f. rambler w/attached garage					2016
New	Approved	basic 15-106942 BP	2012 IRC	Plan# 2766	Rambler sfr w/attached ga	2016
New	Approved	basic 16-114080 BP	2015 IRC	Plan# 2974	2-story sfr w/attached g	2016
New	Approved	basic 15-106946 BP	2012 IRC	Plan# 3602	2-story sfr w/attached gara	2016
New	Approved	basic 15-106946 BP	2012 IRC	Plan# 3602	2-story sfr w/attached gara	2016
New	Approved	basic 15-104014 BP	2012 IRC	Plan# 3591	SFR: rambler w/ finished dayligh	2016
New	Approved	basic 15-106945 BP	2012 IRC	Plan# 2974	2-story sfr w/attached gara	2016
New	Approved	basic 15-106942 BP	2012 IRC	Plan# 2766	Rambler sfr w/attached ga	2016
New	Large rambler with attached garage and covered porch					2016
New	Approved	basic 15-106946 BP	2012 IRC	Plan# 3602	2-story sfr w/attached gara	2016
New	Approved	basic 15-106945 BP	2012 IRC	Plan# 2974	2-story sfr w/attached gara	2016
New	Approved	basic 15-106946 BP	2012 IRC	Plan# 3602	2-story sfr w/attached gara	2016
New	Approved	basic 15-114843 BP	2012 IRC	Plan# 3271	2-story sfr w/attach	2016
New	Approved	basic 15-106946 BP	2012 IRC	Plan# 3602	2-story sfr w/attached gara	2016
New	Extending permit for 30 days- if not finished before April 27th 2018 needs to renew. SFR: new					2016
New	Approved	basic 14-109172 BP	2012 IRC	Plan# 24-40.02 F2 - Henley33	2-story sfr w/a	2016
New	Approved	basic 14-115975 BP	2012 IRC	Plan# 23-40.02 W4 - Henley40	2-story sfr	2016
New	Two story SFR with attached Garage					2016
New	Approved	basic 16-101612 BP	2012 IRC	Plan# 34-30.03 H (.1) - Henley57	2-	2016
New	Approved	basic 14-114967 BP	2012 IRC	Plan# 31-30.12 T - Henley38	2-story sfr w	2016

Accessory Dwelling Units

Index # - File Name: 1.0022 - Single Family Dwellings Data\_Snohomish County.pdf

New	Approved	basic 15-110635 BP	2012 IRC	Plan# 31-30.32 V - Henley53	2-story sfr w	2016
New		2 story sfr w\attached garage				2016
New		2 story sfr w\attached garage				2016
New		2 story sfr w\attached garage				2016
New		2 story sfr w\attached garage				2016
New		2 story sfr w\attached garage				2016
New		2 story sfr w\attached garage				2016
New		2 story sfr w\attached garage				2016
New		2 story sfr w\attached garage				2016
New		2-story sfr w/attached garage				2016
New		2-story sfr w/attached garage				2016
New		2 story sfr w/attached garage				2016
New		2 story sfr w/attached garage				2016
New		2 story sfr w/finished basement & attached garage				2016
New		Rough-in for 2nd kitchen noted at basement at Final; Kitchen not installed; Owner to obtain nev				2016
New		2 story sfr w\ finished basement and attached garage				2016
New		2 story sfr w\ finished basement and attached garage				2016
New		Two story SFR with finished Basement and attached Garage				2016
New		2 story sfr w/attached garage				2016
New		2 story sfr w/finished basement & attached garage				2016
New		2 story sfr w\ finished basement and attached garage				2016
New	Approved	basic 15-112606 BP	2012 IRC	Plan# 2311 B	2-story sfr w/attached garage	2016
New	Approved	basic 15-103241 BP	2012 IRC	Plan# 2137-A	2-story sfr w/attached gar	2016
New	Approved	basic 15-118680 BP	2012 IRC	Plan# 1836A	2-story w/attache	2016
New	Approved	basic 15-103241 BP	2012 IRC	Plan# 2137-A	2-story sfr w/attached gar	2016
New	Approved	basic 15-112645 BP	2012 IRC	Plan# 2501 A	2-story sfr w/attached garage	2016
New	Approved	basic 13-111941.	2012 IRC.	Plan #2573-B.	2 story sfr w/ attached garage.	2016
New	Approved	basic 15-103241 BP	2012 IRC	Plan# 2137-A	2-story sfr w/attached gar	2016
New	Approved	basic 15-112606 BP	2012 IRC	Plan# 2311 B	2-story sfr w/attached garage	2016
New	Approved	basic 15-103241 BP	2012 IRC	Plan# 2137-A	2-story sfr w/attached gar	2016
New	Approved	basic 15-112606 BP	2012 IRC	Plan# 2311 B	2-story sfr w/attached garage	2016
New	Approved	basic 15-103241 BP	2012 IRC	Plan# 2137-A	2-story sfr w/attached gar	2016
New	Approved	basic 15-112606 BP	2012 IRC	Plan# 2311 B	2-story sfr w/attached garage	2016
New	Approved	basic 15-117487 BP	2012 IRC	Plan# 2137B	2-story sfr	2016
New	Approved	Basic 13-111940.	2012 IRC.	Plan #2573-C.	2 story sfr w/ attached }	2016
New	Approved	basic 15-112645 BP	2012 IRC	Plan# 2501 A	2-story sfr w/attached garage	2016
New	Approved	basic 13-111939.	2012 IRC.	Plan #2573-A.	2 story sfr w/ attached	2016
New	Approved	Basic 13-111940.	2012 IRC.	Plan #2573-C.	2 story sfr w/ attached }	2016
New	Approved	basic 15-112646 BP	2012 IRC	Plan# 2501 B	2-story sfr w/attached garage	2016
New	Approved	basic 15-112606 BP	2012 IRC	Plan# 2311 B	2-story sfr w/attached garage	2016
New	Approved	basic 15-117487 BP	2012 IRC	Plan# 2137B	2-story sfr	2016
New	Approved	basic 15-112606 BP	2012 IRC	Plan# 2311 B	2-story sfr w/attached garage	2016
New	Approved	basic 15-112646 BP	2012 IRC	Plan# 2501 B	2-story sfr w/attached garage	2016
New	Approved	basic 13-114146 BP	2012 IRC	Plan# 32-30.02 V4 - Henley12	2-story sfr w/ai	2016
New	Approved	basic 14-109292 BP	2012 IRC	Plan# 22-40.02 S5 - Henley34	2-story sfr w,	2016
New	Approved	basic 15-112532 BP	2012 IRC	Plan# 24-40.02 XA - Henley55	2-story sfr w	2016
New	Approved	basic 16-106485 BP	2012 IRC	Plan# 24-40.02 W4 - Henley61	2-story	2016

Accessory Dwelling Units

Index # - File Name: 1.0022 - Single Family Dwellings Data\_Snohomish County.pdf

New	Approved basic 14-114967 BP	2012 IRC	Plan# 31-30.12 T - Henley38	2-story sfr w	2016	
New	Approved Basic 14-108157 BP	2012 IRC	Plan #34-30.02 H - Henley31	2 story sfr w	2016	
New	Approved basic 16-106526 BP	2012 IRC	Plan# 25-40.02 F2 - Henley62	2-story s	2016	
New	Approved basic 16-101016 BP	2012 IRC	Plan# 40-40.11 XM - henley	2-story v	2016	
New	Approved basic 16-102405 BP	2012 IRC	Plan# 23-40.02 W3 - Henley59	2-story sfr	2016	
New	Approved basic 14-109167 BP	2012 IRC	Plan# 23-40.02 F4 - Henley34	2-story sfr w/a	2016	
New	Approved basic 15-102922 BP	2012 IRC	Plan# 37-40.02 S2 - Henley44	2-story	2016	
New	Approved basic 16-101016 BP	2012 IRC	Plan# 40-40.11 XM - henley	2-story v	2016	
New	Approved basic 15-100713 BP	2012 IRC	Plan# 23-40.02 F - Henley41	2-story sfr w/at	2016	
New	Approved basic 15-103931 BP	2012 IRC	Plan# 21-40.02 XA- Henley45	2-story sfr	2016	
New	Approved basic 15-114623 BP	2012 IRC	Plan# 39-40.02 T - Henley54	2-story	2016	
New	Approved basic 15-107010 BP	2012 IRC	Plan# 34-30.03 T - Henley47	2-story s	2016	
New	Approved basic 15-106293 BP	2012 IRC	Plan# 31-30.12 U8 - Henley47	2-story sfr w/	2016	
New	2-story sfr w/attached garage				2016	
New	Approved basic 14-114967 BP	2012 IRC	Plan# 31-30.12 T - Henley38	2-story sfr w	2016	
New	Two story SFR with attached Garage				2016	
New	Approved basic 15-110635 BP	2012 IRC	Plan# 31-30.32 V - Henley53	2-story sfr w	2016	
New	Approved basic 15-118349 BP	2012 IRC	Plan# 24-40.02 F - Henley 56	2-story	2016	
New	Approved basic 15-101620 BP	2012 IRC	Plan# 34-30.02 T - Henley42	2-story :	2016	
New	Approved basic 16-101612 BP	2012 IRC	Plan# 34-30.03 H (.1) - Henley57	2-	2016	
New	Approved basic 16-111598 BP	2015 IRC	Plan# 2494B	2-story w/attached	2016	
New	Approved basic 16-111957 BP	2015 IRC	Plan# 2501B	2-story w/attached g	2016	
New	Approved basic 16-111598 BP	2015 IRC	Plan# 2494B	2-story w/attached	2016	
New	New 2,664 sf 2-story SFR with 720 sf garage and 80 sf covered porch				2016	
New	Approved basic 16-111598 BP	2015 IRC	Plan# 2494B	2-story w/attached	2016	
New	Approved basic 16-118287 BP	2015 IRC	Plan# 2165	2-story SFR w/ attache	2016	
New	Approved basic 16-112209 BP	2015 IRC	Plan# 2916 AB 2015	2-story w/a	2016	
New	Approved basic 16-112046 BP	2015 IRC	Plan# 2580 AB 2015	2-story w/a	2016	
New	Approved basic 16-112209 BP	2015 IRC	Plan# 2916 AB 2015	2-story w/a	2016	
New	Approved basic 16-112046 BP	2015 IRC	Plan# 2580 AB 2015	2-story w/a	2016	
New	Approved basic 16-112209 BP	2015 IRC	Plan# 2916 AB 2015	2-story w/a	2016	
New	Approved basic 16-112046 BP	2015 IRC	Plan# 2580 AB 2015	2-story w/a	2016	
New	Approved basic 16-112209 BP	2015 IRC	Plan# 2916 AB 2015	2-story w/a	2016	
New	Approved basic 16-112046 BP	2015 IRC	Plan# 2580 AB 2015	2-story w/a	2016	
New	New 2 story SFDU SFR w/ attached garage			UNIT 3	SEE: 16-103	2016
New	New SFDU SFR w/ attached garage			Unit 2		2016
New	New SFDU SFR w/ attached garage			Unit 1		2016
New	New 2-stroy SFR with attached garage				SEE: 16-111636-LDA	2016
New	Approved basic 16-109161 BP	2015 IRC	Plan# Kimball D	2-story sfr w/attached	2016	
New	Approved basic 16-113033 BP	2015 IRC	Plan# Rainier D	2-story sfr w/attached g	2016	
New	Approved basic 16-109158 BP	2015 IRC	Plan# Kimball C	2-story sfr w/attached	2016	
New	Approved Basic 16-113032 BP	2015 IRC	Plan# Rainier C	2-story sfr w/attached g	2016	
New	Approved basic 16-114611 BP	2015 IRC	Plan# Blakely D	2-story sfr w/attached	2016	
New	Approved basic 16-112155 BP	2015 IRC	Plan# Baker D	2-story sfr w/attached ga	2016	
New	Approved basic 16-114005 BP	2015 IRC	Plan# Cascade C	2-story sfr w/attach	2016	
New	Approved basic 16-113278 BP	2015 IRC	Plan# Chelan II D	2-story sfr w/attached gara	2016	
New	Approved basic 16-115149 BP	2015 IRC	Plan# Windom C/D	2-story sfr w/finish	2016	

Accessory Dwelling Units

Index # - File Name: 1.0022 - Single Family Dwellings Data\_Snohomish County.pdf

New	Approved basic 16-115669 BP	2015 IRC	Plan# Aspen D	2-story sfr w/finished baser	2016
New	Approved basic 16-115149 BP	2015 IRC	Plan# Windom C/D	2-story sfr w/finish	2016
New	Approved basic 16-107421 BP	2012 IRC	Plan# 3201	Rambler style sfr w/atta	2016
New	Approved basic 16-107423 BP	2012 IRC	Plan# 3861	Rambler style sfr w/2nd	2016
New	Approved basic 16-107416 BP	2012 IRC	Plan# 2562	Rambler style sfr w/att	2016
New	Approved basic 16-107419 BP	2012 IRC	Plan# 2923	Rambler style sfr w/2n	2016
New	Approved basic 16-107416 BP	2012 IRC	Plan# 2562	Rambler style sfr w/att	2016
New	Approved basic 16-107419 BP	2012 IRC	Plan# 2923	Rambler style sfr w/2n	2016
New	Approved basic 16-107421 BP	2012 IRC	Plan# 3201	Rambler style sfr w/atta	2016
New	Approved basic 16-112155 BP	2015 IRC	Plan# Baker D	2-story sfr w/attached ga	2016
New	Approved basic 16-114609 BP	2015 IRC	Plan# Blakely C	2-story sfr w/attach	2016
New	Approved basic 16-111957 BP	2015 IRC	Plan# 2501B	2-story w/attached g	2016
New	Approved basic 16-114519 BP	2015 IRC	Plan# 2825C	2-story sfr w/atta	2016
New	2 story duplex w/attached garage				2016
New	1977 s.f. rambler w/attached garage	2015 IRC			2016
New	Approved basic 16-117137 BP	2015 IRC	Plan# Kingston C/D	3-story sfr w/t	2016
New	Approved basic 16-115979 BP	2015 IRC	Plan# Amherst C/D	2-story sfr w/ç	2016
New	Approved basic 16-117674 BP	2015 IRC	Plan# Palmer C/D	3-story sfr w/tan	2016
New	Approved basic 16-115979 BP	2015 IRC	Plan# Amherst C/D	2-story sfr w/ç	2016
New	Approved basic 16-117137 BP	2015 IRC	Plan# Kingston C/D	3-story sfr w/t	2016
New	Approved basic 13-112612 BP	2012 IRC	Plan# 3315	2-story sfr w/attached gi	2016
New	Approved basic 15-103376-BP	2012 IRC	Plan# 1335-Duplex	2-story Duplex w,	2016
New	Approved basic 15-112645 BP	2012 IRC	Plan# 2501 A	2-story sfr w/attached garage	2016
New	Approved basic 15-118520 BP	2012 IRC	Plan# 2494A	2-story w/attached	2016
New	Approved basic 15-112645 BP	2012 IRC	Plan# 2501 A	2-story sfr w/attached garage	2016
New	Approved basic 15-112647 BP	2012 IRC	Plan# 2501 C	2-story sfr w/attached garage	2016
New	Approved basic 15-118520 BP	2012 IRC	Plan# 2494A	2-story w/attached	2016
New	Approved basic 15-112606 BP	2012 IRC	Plan# 2311 B	2-story sfr w/attached garage	2016
New	Approved basic 15-118535 BP	2012 IRC	Plan# 2494B	2-story w/attached	2016
New	Approved basic 15-118520 BP	2012 IRC	Plan# 2494A	2-story w/attached	2016
New	Approved basic 15-112645 BP	2012 IRC	Plan# 2501 A	2-story sfr w/attached garage	2016
New	Approved basic 15-118535 BP	2012 IRC	Plan# 2494B	2-story w/attached	2016
New	Approved basic 15-118520 BP	2012 IRC	Plan# 2494A	2-story w/attached	2016
New	Approved basic 15-112647 BP	2012 IRC	Plan# 2501 C	2-story sfr w/attached garage	2016
New	Approved basic 15-118535 BP	2012 IRC	Plan# 2494B	2-story w/attached	2016
New	Approved basic 15-112606 BP	2012 IRC	Plan# 2311 B	2-story sfr w/attached garage	2016
New	Approved basic 15-112645 BP	2012 IRC	Plan# 2501 A	2-story sfr w/attached garage	2016
New	Approved basic 15-112606 BP	2012 IRC	Plan# 2311 B	2-story sfr w/attached garage	2016
New	Approved basic 15-118535 BP	2012 IRC	Plan# 2494B	2-story w/attached	2016
New	Approved basic 15-112645 BP	2012 IRC	Plan# 2501 A	2-story sfr w/attached garage	2016
New	Approved basic 15-118535 BP	2012 IRC	Plan# 2494B	2-story w/attached	2016
New	Approved basic 15-112646 BP	2012 IRC	Plan# 2501 B	2-story sfr w/attached garage	2016
New	Approved basic 15-112645 BP	2012 IRC	Plan# 2501 A	2-story sfr w/attached garage	2016
New	Approved basic 15-118520 BP	2012 IRC	Plan# 2494A	2-story w/attached	2016
New	Approved basic 15-112647 BP	2012 IRC	Plan# 2501 C	2-story sfr w/attached garage	2016
New	Approved basic 15-118535 BP	2012 IRC	Plan# 2494B	2-story w/attached	2016
New	Approved basic 15-112646 BP	2012 IRC	Plan# 2501 B	2-story sfr w/attached garage	2016

Accessory Dwelling Units

Index # - File Name: 1.0022 - Single Family Dwellings Data\_Snohomish County.pdf

New	Approved	basic 15-118520 BP	2012 IRC	Plan# 2494A	2-story w/attached	2016
New	Approved	basic 15-112606 BP	2012 IRC	Plan# 2311 B	2-story sfr w/attached garage	2016
New	Approved	basic 15-118535 BP	2012 IRC	Plan# 2494B	2-story w/attached	2016
New	Approved	basic 15-112606 BP	2012 IRC	Plan# 2311 B	2-story sfr w/attached garage	2016
New	Approved	basic 15-117499 BP	2012 IRC	Plan# 2825B	2-story sfr	2016
New	Approved	basic 15-112647 BP	2012 IRC	Plan# 2501 C	2-story sfr w/attached garage	2016
New	Approved	basic 15-117501 BP	2012 IRC	Plan# 2825C	2-story sfr	2016
New	Approved	basic 15-117499 BP	2012 IRC	Plan# 2825B	2-story sfr	2016
New	Approved	basic 15-112645 BP	2012 IRC	Plan# 2501 A	2-story sfr w/attached garage	2016
New	Approved	basic 15-117517 BP	2012 IRC	Plan# 2825A	2-story sfr	2016
New	Approved	basic 15-118535 BP	2012 IRC	Plan# 2494B	2-story w/attached	2016
New	New 2,915 sf 2-story SFR with 730 sf garage and 205 sf covered porch					2016
New	Approved	basic 14-116493 BP	2012 IRC	Plan# Baker C daylight	2-story sfr w/daylig	2016
New	Approved	basic 15-109997 BP	2012 IRC	Plan# Pilchuck C/D	2-story sfr w/attached	2016
New	Approved	basic 16-101318 BP	2012 IRC	Plan# Trafton C Daylight	3-story sfr w	2016
New	Approved	basic 16-101994 BP	2012 IRC	Plan# Armstrong C/D Daylight	2-story	2016
New	Approved	basic 16-101987 BP	2012 IRC	Plan# Newhalem C Daylight	2-story	2016
New	Approved	basic 16-101088 BP	2012 IRC	Plan# Cavanaugh C/D Daylight	2-story	2016
New	Approved	basic 16-101990 BP	2012 IRC	Plan# Newhalem D Daylight	2-story w	2016
New	Approved	basic 16-101994 BP	2012 IRC	Plan# Armstrong C/D Daylight	2-story	2016
New	Approved	basic 16-101318 BP	2012 IRC	Plan# Trafton C Daylight	3-story sfr w	2016
New	Approved	basic 16-101987 BP	2012 IRC	Plan# Newhalem C Daylight	2-story	2016
New	Approved	basic 16-101319 BP	2012 IRC	Plan# Trafton D Daylight	3-story sfr w/at	2016
New	Approved	basic 16-101088 BP	2012 IRC	Plan# Cavanaugh C/D Daylight	2-story	2016
New	Approved	basic 16-101088 BP	2012 IRC	Plan# Cavanaugh C/D Daylight	2-story	2016
New	Approved	basic 16-101994 BP	2012 IRC	Plan# Armstrong C/D Daylight	2-story	2016
New	Approved	basic 16-101319 BP	2012 IRC	Plan# Trafton D Daylight	3-story sfr w/at	2016
New	Approved	basic 16-101088 BP	2012 IRC	Plan# Cavanaugh C/D Daylight	2-story	2016
New	Approved	basic 16-101987 BP	2012 IRC	Plan# Newhalem C Daylight	2-story	2016
New	Approved	basic 16-101994 BP	2012 IRC	Plan# Armstrong C/D Daylight	2-story	2016
New	Approved	basic 16-101088 BP	2012 IRC	Plan# Cavanaugh C/D Daylight	2-story	2016
New	Approved	basic 16-101990 BP	2012 IRC	Plan# Newhalem D Daylight	2-story w	2016
New	Approved	basic 15-107152 BP	2012 IRC	Plan# Dayton D	2-story sfr w/attached g	2016
New	Approved	basic 15-117474 BP	2012 IRC	Plan# Trafton D	2-story sfr w/attached g	2016
New	Approved	basic 16-100166 BP	2012 IRC	Plan# Cavanaugh C/D	2-story sfr w/at	2016
New	Extended permit for a month- if not finished by Feb 27, 2018 needs to renew. New 2-story SFI					2016
New	Approved	basic 16-102745 BP	2012 IRC	Plan# 2301-02 AB	3-story sfr w/attacl	2016
New	Approved	basic 14-111141 BP	2012	Plan# 2518-02AB	3-story sfr w/attached g	2016
New	Approved	basic 16-102745 BP	2012 IRC	Plan# 2301-02 AB	3-story sfr w/attacl	2016
New	Approved	basic 14-111141 BP	2012	Plan# 2518-02AB	3-story sfr w/attached g	2016
New	Approved	basic 14-111141 BP	2012	Plan# 2518-02AB	3-story sfr w/attached g	2016
New	Approved	basic 14-111141 BP	2012	Plan# 2518-02AB	3-story sfr w/attached g	2016
New	Approved	basic 16-102745 BP	2012 IRC	Plan# 2301-02 AB	3-story sfr w/attacl	2016
New	Approved	basic 16-102745 BP	2012 IRC	Plan# 2301-02 AB	3-story sfr w/attacl	2016
New	Approved	basic 14-111141 BP	2012	Plan# 2518-02AB	3-story sfr w/attached g	2016
New	Approved	basic 16-102745 BP	2012 IRC	Plan# 2301-02 AB	3-story sfr w/attacl	2016
New	Approved	basic 14-111141 BP	2012	Plan# 2518-02AB	3-story sfr w/attached g	2016

Accessory Dwelling Units

Index # - File Name: 1.0022 - Single Family Dwellings Data\_Snohomish County.pdf

New	Approved basic 16-102745 BP	2012 IRC	Plan# 2301-02 AB	3-story sfr w/attach	2016
New	Approved basic 16-103221 BP	2012 IRC	Plan# 2548-02 AB	2-story sfr w/baser	2016
New	Approved basic 16-103432 BP	2012 IRC	Plan# 2758-02 AB	3-story sfr w/attach	2016
New	Approved basic 16-103221 BP	2012 IRC	Plan# 2548-02 AB	2-story sfr w/baser	2016
New	Approved basic 16-103221 BP	2012 IRC	Plan# 2548-02 AB	2-story sfr w/baser	2016
New	Approved basic 16-103432 BP	2012 IRC	Plan# 2758-02 AB	3-story sfr w/attach	2016
New	Approved basic 16-103221 BP	2012 IRC	Plan# 2548-02 AB	2-story sfr w/baser	2016
New	Approved basic 16-103432 BP	2012 IRC	Plan# 2758-02 AB	3-story sfr w/attach	2016
New	Approved basic 16-103221 BP	2012 IRC	Plan# 2548-02 AB	2-story sfr w/baser	2016
New	Approved basic 16-103432 BP	2012 IRC	Plan# 2758-02 AB	3-story sfr w/attach	2016
New	Approved basic 16-103221 BP	2012 IRC	Plan# 2548-02 AB	2-story sfr w/baser	2016
New	Approved basic 16-103432 BP	2012 IRC	Plan# 2758-02 AB	3-story sfr w/attach	2016
New	Approved basic 15-117517 BP	2012 IRC	Plan# 2825A	2-story sfr	2016
New	Approved basic 14-113399 BP	2012 IRC	Plan# 3017A	2-story sfr w/attached garage	2016
New	Approved basic 15-117655 BP	2012 IRC	Plan# 2702B	2-story sfr	2016
New	Approved basic 14-113401 BP	2012 IRC	Plan# 3017C	2-story sfr w/attach	2016
New	Approved basic 14-113401 BP	2012 IRC	Plan# 3017C	2-story sfr w/attach	2016
New	Approved basic 15-118520 BP	2012 IRC	Plan# 2494A	2-story w/attached	2016
New	Approved basic 14-113400 BP	2012 IRC	Plan# 3017B	2-story sfr w/attach	2016
New	Approved basic 15-112647 BP	2012 IRC	Plan# 2501 C	2-story sfr w/attached garage	2016
New	Approved basic 16-115677 BP	2015 IRC	Plan# 3017C	2-story sfr w/attache	2016
New	Approved basic 15-112661 BP	2012 IRC	Plan# 3183 C	2-story sfr w/attached garage	2016
New	Approved basic 15-118520 BP	2012 IRC	Plan# 2494A	2-story w/attached	2016
New	Approved basic 15-112645 BP	2012 IRC	Plan# 2501 A	2-story sfr w/attached garage	2016
New	Approved basic 15-112660 BP	2012 IRC	Plan# 3183 B	2-story sfr w/attached garage	2016
New	Approved basic 14-113401 BP	2012 IRC	Plan# 3017C	2-story sfr w/attach	2016
New	Approved basic 15-117517 BP	2012 IRC	Plan# 2825A	2-story sfr	2016
New	Approved basic 15-112660 BP	2012 IRC	Plan# 3183 B	2-story sfr w/attached garage	2016
New	Approved basic 14-113400 BP	2012 IRC	Plan# 3017B	2-story sfr w/attache	2016
New	Approved basic 15-112658 BP	2012 IRC	Plan# 3183 A	2-story sfr w/attached garage	2016
New	Approved basic 14-113399 BP	2012 IRC	Plan# 3017A	2-story sfr w/attached garage	2016
New	Approved basic 15-112658 BP	2012 IRC	Plan# 3183 A	2-story sfr w/attached garage	2016
New	Approved basic 15-112645 BP	2012 IRC	Plan# 2501 A	2-story sfr w/attached garage	2016
New	Approved basic 14-113399 BP	2012 IRC	Plan# 3017A	2-story sfr w/attached garage	2016
New	Approved basic 15-117655 BP	2012 IRC	Plan# 2702B	2-story sfr	2016
New	Approved basic 14-113400 BP	2012 IRC	Plan# 3017B	2-story sfr w/attache	2016
New	Approved basic 15-112661 BP	2012 IRC	Plan# 3183 C	2-story sfr w/attached garage	2016
New	Approved basic 14-113401 BP	2012 IRC	Plan# 3017C	2-story sfr w/attach	2016
New	Approved basic 15-112660 BP	2012 IRC	Plan# 3183 B	2-story sfr w/attached garage	2016
New	Approved basic 16-115677 BP	2015 IRC	Plan# 3017C	2-story sfr w/attache	2016
New	Approved basic 16-114521 BP	2015 IRC	Plan# 2825B	2-story sfr w/attac	2016
New	Approved basic 16-114519 BP	2015 IRC	Plan# 2825C	2-story sfr w/atta	2016
New	Approved basic 16-111598 BP	2015 IRC	Plan# 2494B	2-story w/attached	2016
New	Approved basic 15-117655 BP	2012 IRC	Plan# 2702B	2-story sfr	2016
New	Approved basic 13-107399	2012 IRC	Plan 3624-RV	2 story sfr w/ attached garage :	2016
New	New 3,692 sf 2-story SFR with 968 sf garage, 367 covered porch, 277 sf deck				2016
New	2-story sfr w/attached garage				2016



Accessory Dwelling Units

Index # - File Name: 1.0022 - Single Family Dwellings Data\_Snohomish County.pdf

New	Approved	basic 13-107401.	2012 IRC.	Plan 3494 4 car.	2 story sfr w/ attached 4 car	2016
New	Approved	basic 13-107399.	2012 IRC.	Plan 3624-RV.	2 story sfr w/ attached garage	2016
New	Approved	basic 13-107401.	2012 IRC.	Plan 3494 4 car.	2 story sfr w/ attached 4 car	2016
New	Approved	basic 15-114843 BP	2012 IRC	Plan# 3271	2-story sfr w/attach	2016
New	Approved	basic 15-108670 BP	2012 IRC	Plan# 2100	Rambler style sfr v	2016
New	SFR: new	2 story home, with attached 4 car garage, 4 bedroom/3.5 baths plus a bonus room and				2016
New	Approved	basic 15-107154 BP	2012 IRC	Plan# 3656 Daylight	Rambler style	2016
New	Approved	basic 14-112959 BP	2012 IRC	Plan# 3017	2-story sfr w/attached gar	2016
New	Approved	basic 14-109886 BP	2012 IRC	Plan# 2322	Rambler style sfr w/attached g	2016
New	Approved	basic 16-100166 BP	2012 IRC	Plan# Cavanaugh C/D	2-story sfr w/at	2016
New	Approved	basic 15-117473 BP	2012 IRC	Plan# Trafton C	2-story sfr w/attached	2016
New	Approved	basic 16-100166 BP	2012 IRC	Plan# Cavanaugh C/D	2-story sfr w/at	2016
New	Approved	basic 15-107152 BP	2012 IRC	Plan# Dayton D	2-story sfr w/attached g	2016
New	Approved	basic 15-110114 BP	2012 IRC	Plan# Hazelwood-D	2-story sfr w/attached gar	2016
New	Approved	basic 16-100166 BP	2012 IRC	Plan# Cavanaugh C/D	2-story sfr w/at	2016
New	Approved	basic 15-102332 BP	2012 IRC	Plan# Rainier C	2-story sfr w/attached gara	2016
New	Approved	basic 15-107151 BP	2012 IRC	Plan# Dayton C	2-story sfr w/attached ga	2016
New	Approved	basic 15-117474 BP	2012 IRC	Plan# Trafton D	2-story sfr w/attached g	2016
New	Approved	basic 16-101990 BP	2012 IRC	Plan# Newhalem D Daylight	2-story w	2016
New	Approved	basic 16-101088 BP	2012 IRC	Plan# Cavanaugh C/D Daylight	2-story	2016
New	Approved	basic 16-101318 BP	2012 IRC	Plan# Trafton C Daylight	3-story sfr w	2016
New	Approved	basic 16-101088 BP	2012 IRC	Plan# Cavanaugh C/D Daylight	2-story	2016
New	Approved	basic 16-101987 BP	2012 IRC	Plan# Newhalem C Daylight	2-story	2016
New	Approved	basic 16-101319 BP	2012 IRC	Plan# Trafton D Daylight	3-story sfr w/fi	2016
New	Approved	basic 15-102333 BP	2012 IRC	Plan# Rainer D	2-story sfr w/attached g	2016
New	Approved	basic 15-117473 BP	2012 IRC	Plan# Trafton C	2-story sfr w/attached	2016
New	Approved	basic 15-107152 BP	2012 IRC	Plan# Dayton D	2-story sfr w/attached g	2016
New	Approved	basic 15-110114 BP	2012 IRC	Plan# Hazelwood-D	2-story sfr w/attached gar	2016
New	Approved	basic 15-111287 BP	2012 IRC	Plan# Granite C	2-story sfr w/attached ga	2016
New	Approved	basic 15-107151 BP	2012 IRC	Plan# Dayton C	2-story sfr w/attached ga	2016
New	Approved	basic 16-100166 BP	2012 IRC	Plan# Cavanaugh C/D	2-story sfr w/at	2016
New	Approved	basic 15-110460 BP	2012 IRC	Plan# Campbell II D	2-story sfr w/attached gar	2016
New	Approved	basic 15-111285 BP	2012 IRC	Plan# Granite D	2-story sfr w/attached gara	2016
New	Approved	basic 16-103808 BP	2012 IRC	Plan# Kimball D	2-story sfr w/attached g	2016
New	Approved	basic 15-102333 BP	2012 IRC	Plan# Rainer D	2-story sfr w/attached g	2016
New	Approved	basic 16-103807 BP	2012 IRC	Plan# Kimball C	2-story sfr w/attached g	2016
New	Approved	basic 15-107152 BP	2012 IRC	Plan# Dayton D	2-story sfr w/attached g	2016
New	Approved	basic 16-100166 BP	2012 IRC	Plan# Cavanaugh C/D	2-story sfr w/at	2016
New	Approved	basic 15-110460 BP	2012 IRC	Plan# Campbell II D	2-story sfr w/attached gar	2016
New	Approved	basic 15-117473 BP	2012 IRC	Plan# Trafton C	2-story sfr w/attached	2016
New	Approved	basic 16-100166 BP	2012 IRC	Plan# Cavanaugh C/D	2-story sfr w/at	2016
New	Approved	basic 15-117474 BP	2012 IRC	Plan# Trafton D	2-story sfr w/attached g	2016
New	Approved	basic 16-103807 BP	2012 IRC	Plan# Kimball C	2-story sfr w/attached g	2016
New	Approved	basic 15-117473 BP	2012 IRC	Plan# Trafton C	2-story sfr w/attached	2016
New	Approved	basic 16-103807 BP	2012 IRC	Plan# Kimball C	2-story sfr w/attached g	2016
New	Approved	basic 15-102332 BP	2012 IRC	Plan# Rainier C	2-story sfr w/attached gara	2016
New	Approved	basic 15-117473 BP	2012 IRC	Plan# Trafton C	2-story sfr w/attached	2016

Accessory Dwelling Units

Index # - File Name: 1.0022 - Single Family Dwellings Data\_Snohomish County.pdf

New	Approved basic 16-100166 BP	2012 IRC	Plan# Cavanaugh C/D	2-story sfr w/att	2016
New	Approved basic 15-110460 BP	2012 IRC	Plan# Campbell II D	2-story sfr w/attached gar	2016
New	Approved basic 15-111285 BP	2012 IRC	Plan# Granite D	2-story sfr w/attached gara	2016
New	Approved basic 15-110460 BP	2012 IRC	Plan# Campbell II D	2-story sfr w/attached gar	2016
New	Approved basic 15-111287 BP	2012 IRC	Plan# Granite C	2-story sfr w/attached ga	2016
New	Approved basic 15-102333 BP	2012 IRC	Plan# Rainer D	2-story sfr w/attached g	2016
New	Approved basic 16-103807 BP	2012 IRC	Plan# Kimball C	2-story sfr w/attached g	2016
New	Approved basic 15-102333 BP	2012 IRC	Plan# Rainer D	2-story sfr w/attached g	2016
New	Approved basic 15-117473 BP	2012 IRC	Plan# Trafton C	2-story sfr w/attached	2016
New	Approved basic 15-117471 BP	2012 IRC	Plan# Newhalem C	2-story sfr w/attached	2016
New	Approved basic 16-100166 BP	2012 IRC	Plan# Cavanaugh C/D	2-story sfr w/att	2016
New	Approved basic 15-117471 BP	2012 IRC	Plan# Newhalem C	2-story sfr w/attached	2016
New	Approved basic 15-107151 BP	2012 IRC	Plan# Dayton C	2-story sfr w/attached ga	2016
New	Approved basic 15-111287 BP	2012 IRC	Plan# Granite C	2-story sfr w/attached ga	2016
New	Approved basic 16-112155 BP	2015 IRC	Plan# Baker D	2-story sfr w/attached ga	2016
New	two-story 6 BR duplex NSF Check - Accept only cash, bank draft, money order or credit card.				2016
New	Approved basic 15-107152 BP	2012 IRC	Plan# Dayton D	2-story sfr w/attached g	2016
New	New 2,271 sf SFR with 488 sf garage and 124 sf covered porch				2016
New	New 2 story SFR with attached garage.			SEI	2016
New	4 BR rambler with attached garage				2016
New	New 2,123 sf 2-story SFR with 500 sf garage and 166 sf deck				2016
New	New 2,123 sf 2-story SFR with 500 sf garage and 166 sf deck				2016
New	Two story 4 BR SFR with attached garage and covered porch				2016
New	Two Story SFR with attached Garage				2016
New	Two story SFR with attached Garage				2016
New	Two story SFR with Finished Basement and attached Garage				2016
New	2274 rambler w/attached garage				2016
New	2223 s.f. rambler w/attached garage				2016
New	Approved basic 16-110832 BP	2012 IRC	Plan# Johnson s Ranch Rambler	Single	2016
New	Approved basic 16-113867 BP	2015 IRC	Plan# Newhalem D	2-story sfr w/attache	2016
New	Approved basic 16-108598 BP	2015 IRC	Plan# Dayton D	2-story sfr w/attached ga	2016
New	Approved basic 16-113330 BP	2015 IRC	Plan# Trafton D	2-story sfr w/attached g	2016
New	Approved basic 16-108632 BP	2015 IRC	Plan# Cavanaugh C/D	2-story sfr w/att	2016
New	Two story SFR with Finished Basement and attached Garage				2016
New	Approved basic 16-110832 BP	2012 IRC	Plan# Johnson s Ranch Rambler	Single	2016
New	Approved basic 15-108655 BP	2012 IRC	Plan# Johnson s Ranch Rambler	Single	2016
New	Approved basic 16-110832 BP	2012 IRC	Plan# Johnson s Ranch Rambler	Single	2016
New	Approved basic 16-113865 BP	2015 IRC	Plan # Newhalem C	2-story sfr w/attac	2016
New	Approved basic 16-109065 BP	2015 IRC	Plan# Pilchuck C/D	2-story sfr w/attach	2016
New	Approved basic 16-108597 BP	2015 IRC	Plan# Dayton C	2-story sfr w/attached ;	2016
New	Approved basic 16-108632 BP	2015 IRC	Plan# Cavanaugh C/D	2-story sfr w/att	2016
New	Approved basic 16-109065 BP	2015 IRC	Plan# Pilchuck C/D	2-story sfr w/attach	2016
New	Approved basic 16-113276 BP	2015 IRC	Plan# Chelan II C	2-story sfr w/attached	2016
New	Approved basic 16-113865 BP	2015 IRC	Plan # Newhalem C	2-story sfr w/attac	2016
New	Approved basic 16-108598 BP	2015 IRC	Plan# Dayton D	2-story sfr w/attached gar	2016
New	Approved Basic 16-113032 BP	2015 IRC	Plan# Rainier C	2-story sfr w/attached g	2016
New	Approved basic 16-108598 BP	2015 IRC	Plan# Dayton D	2-story sfr w/attached gar	2016

Accessory Dwelling Units

Index # - File Name: 1.0022 - Single Family Dwellings Data\_Snohomish County.pdf

New	Approved	basic 16-113328 BP	2015 IRC	Plan# Trafton C	2-story sfr w/attached	2016
New	Approved	basic 16-108632 BP	2015 IRC	Plan# Cavanaugh C/D	2-story sfr w/att	2016
New	Approved	basic 16-108597 BP	2015 IRC	Plan# Dayton C	2-story sfr w/attached	2016
New	Approved	basic 16-113033 BP	2015 IRC	Plan# Rainier D	2-story sfr w/attached g	2016
New	Approved	basic 16-108242 BP	2015 IRC	Plan# Cascade D	2-story sfr w/basement &	2016
New	Approved	basic 16-112022 BP	2015 IRC	Plan# Trafton D Daylight	2-stor	2016
New	Approved	basic 16-114609 BP	2015 IRC	Plan# Blakely C	2-story sfr w/attach	2016
New	Approved	basic 16-108632 BP	2015 IRC	Plan# Cavanaugh C/D	2-story sfr w/att	2016
New	Approved	basic 16-113328 BP	2015 IRC	Plan# Trafton C	2-story sfr w/attached	2016
New	Approved	basic 16-108632 BP	2015 IRC	Plan# Cavanaugh C/D	2-story sfr w/att	2016
New	Approved	basic 16-113033 BP	2015 IRC	Plan# Rainier D	2-story sfr w/attached g	2016
New	Approved	basic 16-113330 BP	2015 IRC	Plan# Trafton D	2-story sfr w/attached	2016
New	Approved	basic 16-113867 BP	2015 IRC	Plan# Newhalem D	2-story sfr w/attache	2016
New	Approved	Basic 16-113032 BP	2015 IRC	Plan# Rainier C	2-story sfr w/attached g	2016
New	Approved	basic 16-114609 BP	2015 IRC	Plan# Blakely C	2-story sfr w/attach	2016
New	Approved	basic 16-109065 BP	2015 IRC	Plan# Pilchuck C/D	2-story sfr w/attach	2016
New	Approved	Basic 16-118651 BP	2015 IRC	Plan# Jefferson A/B	2-story sfr w/at	2016
New	New 4,244 sf rambler with 940 sf garage and 1,297 sf covered deck					2016
New	2 story sfr w/attached garage					2016
New	2 story sfr w/attached garage					2016
New	2 story sfr w/attached garage					2016
New	2 story sfr w/attached garage					2016
New	Approved	basic 16-104202 BP	2012 IRC	Plan# D114-B	2-story Duplex w/i	2016
New	Approved	basic 16-105955 BP	2012 IRC	Plan# D115-A	2-story duplex w/attach	2016
New	Approved	basic 16-104200 BP	2012 IRC	Plan# D114-A	2-story Duplex w	2016
New	Approved	basic 16-105956 BP	2012 IRC	Plan# D115-B	2-story duplex w/attach	2016
New	Approved	basic 16-105955 BP	2012 IRC	Plan# D115-A	2-story duplex w/attach	2016
New	Approved	basic 16-104200 BP	2012 IRC	Plan# D114-A	2-story Duplex w	2016
New	Approved	basic 16-105956 BP	2012 IRC	Plan# D115-B	2-story duplex w/attach	2016
New	Approved	basic 16-104200 BP	2012 IRC	Plan# D114-A	2-story Duplex w	2016
New	Approved	basic 16-105955 BP	2012 IRC	Plan# D115-A	2-story duplex w/attach	2016
New	Approved	basic 16-104202 BP	2012 IRC	Plan# D114-B	2-story Duplex w/i	2016
New	Approved	basic 16-105956 BP	2012 IRC	Plan# D115-B	2-story duplex w/attach	2016
New	Approved	basic 16-105955 BP	2012 IRC	Plan# D115-A	2-story duplex w/attach	2016
New	Approved	basic 16-105956 BP	2012 IRC	Plan# D115-B	2-story duplex w/attach	2016
New	Approved	basic 16-104200 BP	2012 IRC	Plan# D114-A	2-story Duplex w	2016
New	Approved	basic 16-105956 BP	2012 IRC	Plan# D115-B	2-story duplex w/attach	2016
New	Approved	basic 16-104200 BP	2012 IRC	Plan# D114-A	2-story Duplex w	2016
New	Approved	basic 16-105956 BP	2012 IRC	Plan# D115-B	2-story duplex w/attach	2016
New	Approved	basic 16-104202 BP	2012 IRC	Plan# D114-B	2-story Duplex w/i	2016
New	Approved	basic 16-105955 BP	2012 IRC	Plan# D115-A	2-story duplex w/attach	2016
New	Approved	basic 16-105956 BP	2012 IRC	Plan# D115-B	2-story duplex w/attach	2016
New	Approved	basic 16-105955 BP	2012 IRC	Plan# D115-A	2-story duplex w/attach	2016
New	Approved	basic 16-104202 BP	2012 IRC	Plan# D114-B	2-story Duplex w/i	2016
New	Approved	basic #16-114754 BP	2015 IRC	Plan # 3720-B	2 story	2016
New	2 story sfr w/attached garage					2016

Accessory Dwelling Units

Index # - File Name: 1.0022 - Single Family Dwellings Data\_Snohomish County.pdf

New	Approved basic #16-114624 BP	2015 IRC	Plan # 3733-B	2 stor	2016
New	Approved basic 16-111959 BP	2015 IRC	Plan# 2501C	2-story w/attached g	2016
New	Approved basic 16-111957 BP	2015 IRC	Plan# 2501B	2-story w/attached g	2016
New	Approved basic 16-111955 BP	2015 IRC	Plan# 2501A	2-story w/attached g	2016
New	Approved basic 16-111597 BP	2015 IRC	Plan# 2494A	2-story w/attache	2016
New	Approved basic 16-111955 BP	2015 IRC	Plan# 2501A	2-story w/attached g	2016
New	Approved basic 16-111598 BP	2015 IRC	Plan# 2494B	2-story w/attached	2016
New	Approved basic 16-111959 BP	2015 IRC	Plan# 2501C	2-story w/attached g	2016
New	Approved basic 16-113046 BP	2015 IRC	Plan# 1914A	2-story w/attached	2016
New	Approved basic 16-111597 BP	2015 IRC	Plan# 2494A	2-story w/attache	2016
New	Approved basic 16-111955 BP	2015 IRC	Plan# 2501A	2-story w/attached g	2016
New	Approved basic 16-113047 BP	2015 IRC	Plan# 1914B	2-story w/attached g	2016
New	Approved basic 16-111959 BP	2015 IRC	Plan# 2501C	2-story w/attached g	2016
New	Approved basic 16-111598 BP	2015 IRC	Plan# 2494B	2-story w/attached	2016
New	Approved basic 16-113046 BP	2015 IRC	Plan# 1914A	2-story w/attached	2016
New	Approved basic 16-111955 BP	2015 IRC	Plan# 2501A	2-story w/attached g	2016
New	Approved basic 16-111597 BP	2015 IRC	Plan# 2494A	2-story w/attache	2016
New	Approved basic 16-111598 BP	2015 IRC	Plan# 2494B	2-story w/attached	2016
New	Approved basic 16-111957 BP	2015 IRC	Plan# 2501B	2-story w/attached g	2016
New	Approved basic 16-111598 BP	2015 IRC	Plan# 2494B	2-story w/attached	2016
New	Approved basic 16-118113 BP	2015 IRC	Plan# 2311B	2-story sfr w/att	2016
New	Approved basic 16-111959 BP	2015 IRC	Plan# 2501C	2-story w/attached g	2016
New	Approved basic 16-111597 BP	2015 IRC	Plan# 2494A	2-story w/attache	2016
New	Approved basic 16-118113 BP	2015 IRC	Plan# 2311B	2-story sfr w/att	2016
New	Approved basic 16-111957 BP	2015 IRC	Plan# 2501B	2-story w/attached g	2016
New	Approved basic 16-111597 BP	2015 IRC	Plan# 2494A	2-story w/attache	2016
New	Approved basic 16-113047 BP	2015 IRC	Plan# 1914B	2-story w/attached g	2016
New	2 story sfr w/attached garage				2016
New	2 story sfr w/attached garage				2016
New	2 story sfr w/attached garage				2016
New	Approved basic 13-110770 BP	2012 IRC	Plan: 2364	Two-story SFR with attached g	2016
New	Approved basic 16-109911 BP	2012 IRC	Plan# 2039	Rambler style sfr w/	2016
New	Approved 15-106657 BP	2012 IRC	Plan# 2685	2-story sfr w/attached garag	2016
New	2907 s.f. rambler w/attached garage				2016
New	Approved basic 14-109882 BP	2012 IRC	Plan# 2115	Rambler style sfr w/atta	2016
New	2 story sfr w/attached garage				2016
New	2 story sfr w/attached garage				2016
New	2 story sfr w/attached garage				2016
New	New SFR Rambler with attached garage			SEE: 16-10	2016
New	New 2,901 2-story SFR with 324 sf garage and 110 sf deck				2016
New	New-2 story SFR w/ attached garage			SEE: 16-108193-LD	2016
New	Approved basic 13-110770 BP	2012 IRC	Plan: 2364	Two-story SFR with attached g	2016
New	Approved basic #16-114623 BP	2015 IRC	Plan # 3733-A	2 sto	2016
New	Approved basic #16-114624 BP	2015 IRC	Plan # 3733-B	2 stor	2016
New	New 2,262 sf SFR with 735 sf garage, 318 sf covered porch, and 80 sf deck				2016
New	3448 s.f. rambler w/attached garage				2016
New	2 story sfr w/attached garage				2016

Accessory Dwelling Units

Index # - File Name: 1.0022 - Single Family Dwellings Data\_Snohomish County.pdf

New	2 story sfr w/attached garage					2016
New	Approved basic 15-108670 BP	2012 IRC	Plan# 2100		Rambler style sfr v	2016
New	Approved basic 14-109886 BP	2012 IRC	Plan# 2322		Rambler style sfr w/attached g	2016
New	2373 s.f. rambler w/attached garage					2016
New	Approved basic 16-109911 BP	2012 IRC	Plan# 2039		Rambler style sfr w,	2016
New	2-story Duplex w/attached garage					2016
New	Approved basic 16-111714 BP	2015 IRC	Plan# 2014 plan		2- story SFR w/attached g	2016
New	Approved basic 15-102321 BP	2012 IRC	Plan# 2439		Rambler style sfr w/attachec	2016
New	Approved basic 15-102319 BP	2012 IRC	Plan# 2225		Rambler style sfr w/attached	2016
New	2194 s.f. sfr w/400 s.f. finished basement & attached garage					2016
New	2194 s.f. sfr w/400 s.f. finished basement & attached garage					2016
New	New 2194 sf SFR with 657 sf garage and 380 sf covered porch					2016
New	Approved basic 16-108061 BP	2012 IRC	Plan# 2515-2		2-story sfr w/attachec	2016
New	Approved basic 16-108062 BP	2012 IRC	Plan# 2384-2		2-story sfr w/attached	2016
New	Approved basic 16-108061 BP	2012 IRC	Plan# 2515-2		2-story sfr w/attachec	2016
New	Approved basic 16-108062 BP	2012 IRC	Plan# 2384-2		2-story sfr w/attached	2016
New	Approved basic 16-108061 BP	2012 IRC	Plan# 2515-2		2-story sfr w/attachec	2016
New	Approved basic 16-108062 BP	2012 IRC	Plan# 2384-2		2-story sfr w/attached	2016
New	Approved basic 16-108061 BP	2012 IRC	Plan# 2515-2		2-story sfr w/attachec	2016
New	Approved basic 16-108062 BP	2012 IRC	Plan# 2384-2		2-story sfr w/attached	2016
New	Approved basic 16-108061 BP	2012 IRC	Plan# 2515-2		2-story sfr w/attachec	2016
New	Approved basic 16-108062 BP	2012 IRC	Plan# 2384-2		2-story sfr w/attached	2016
New	Approved basic 16-108061 BP	2012 IRC	Plan# 2515-2		2-story sfr w/attachec	2016
New	Approved basic 16-108062 BP	2012 IRC	Plan# 2384-2		2-story sfr w/attached	2016
New	Approved basic 16-108061 BP	2012 IRC	Plan# 2515-2		2-story sfr w/attachec	2016
New	Approved basic 16-108062 BP	2012 IRC	Plan# 2384-2		2-story sfr w/attached	2016
New	Approved basic 16-108061 BP	2012 IRC	Plan# 2515-2		2-story sfr w/attachec	2016
New	Approved basic 16-108062 BP	2012 IRC	Plan# 2384-2		2-story sfr w/attached	2016
New	Approved basic 16-108061 BP	2012 IRC	Plan# 2515-2		2-story sfr w/attachec	2016
New	Approved basic 16-108062 BP	2012 IRC	Plan# 2384-2		2-story sfr w/attached	2016
New	Approved basic 16-108063 BP	2012 IRC	Plan# 2435		2-story sfr w/basement &	2016
New	Approved basic 16-108063 BP	2012 IRC	Plan# 2435		2-story sfr w/basement &	2016
New	Approved basic 16-108063 BP	2012 IRC	Plan# 2435		2-story sfr w/basement &	2016
New	Approved basic 16-108063 BP	2012 IRC	Plan# 2435		2-story sfr w/basement &	2016
New	Approved basic 16-108063 BP	2012 IRC	Plan# 2435		2-story sfr w/basement &	2016
New	Approved basic 16-108063 BP	2012 IRC	Plan# 2435		2-story sfr w/basement &	2016
New	1978 square foot SFR with attached Garage					2016
New	Approved basic 16-110385 BP	2012 IRC	Plan# 2479		Rambler style sfr w/i	2016
New	Approved basic 16-110385 BP	2012 IRC	Plan# 2479		Rambler style sfr w/i	2016
New	Approved basic 16-108062 BP	2012 IRC	Plan# 2384-2		2-story sfr w/attached	2016
New	Approved basic 16-108061 BP	2012 IRC	Plan# 2515-2		2-story sfr w/attachec	2016
New	Approved basic 16-108062 BP	2012 IRC	Plan# 2384-2		2-story sfr w/attached	2016
New	1534 square foot SFR with attached 472 square foot Garage					2016

Accessory Dwelling Units

Index # - File Name: 1.0022 - Single Family Dwellings Data\_Snohomish County.pdf

New	3599 s.f. rambler w/attached garage					2016
New	2573 square foot SFR with attached Garage				SF	2016
New	Approved Basic 16-101556 BP	2012 IRC	Plan# Kitsap	Rambler w/attach		2016
New	Approved Basic 16-101561 BP	2012 IRC	Plan# James	Rambler w/attach		2016
New	Approved Basic 16-101556 BP	2012 IRC	Plan# Kitsap	Rambler w/attach		2016
New	Approved Basic 16-101556 BP	2012 IRC	Plan# Kitsap	Rambler w/attach		2016
New	Approved Basic 16-101561 BP	2012 IRC	Plan# James	Rambler w/attach		2016
New	Approved Basic 16-101561 BP	2012 IRC	Plan# James	Rambler w/attach		2016
New	Approved Basic 16-101556 BP	2012 IRC	Plan# Kitsap	Rambler w/attach		2016
New	Approved Basic 16-101556 BP	2012 IRC	Plan# Kitsap	Rambler w/attach		2016
New	Approved Basic 16-101561 BP	2012 IRC	Plan# James	Rambler w/attach		2016
New	Approved Basic 16-101561 BP	2012 IRC	Plan# James	Rambler w/attach		2016
New	Approved Basic 16-101556 BP	2012 IRC	Plan# Kitsap	Rambler w/attach		2016
New	Approved Basic 16-101556 BP	2012 IRC	Plan# Kitsap	Rambler w/attach		2016
New	Approved Basic 16-101561 BP	2012 IRC	Plan# James	Rambler w/attach		2016
New	Approved Basic 16-101561 BP	2012 IRC	Plan# James	Rambler w/attach		2016
New	Approved Basic 16-101556 BP	2012 IRC	Plan# Kitsap	Rambler w/attach		2016
New	Approved Basic 16-101556 BP	2012 IRC	Plan# Kitsap	Rambler w/attach		2016
New	Approved Basic 16-101561 BP	2012 IRC	Plan# James	Rambler w/attach		2016
New	Approved Basic 16-101561 BP	2012 IRC	Plan# James	Rambler w/attach		2016
New	375 cover over an existing cement patio					2016
New	Approved basic 15-115308 BP	2012 IRC	Plan# 1823	2-story sfr w/attached		2016
New	Approved basic 15-115786 BP	2012 IRC	Plan# 1758	2-story sfr w/attach		2016
New	Approved basic 15-115309 BP	2012 IRC	Plan# 1662	2-story sfr w/attach		2016
New	Approved basic 15-115308 BP	2012 IRC	Plan# 1823	2-story sfr w/attached g		2016
New	Approved basic 15-115786 BP	2012 IRC	Plan# 1758	2-story sfr w/attach		2016
New	Approved basic 15-115309 BP	2012 IRC	Plan# 1662	2-story sfr w/attache		2016
New	4 BR 2-story SFR unfinished basement and attached garage, deck and covered porch					2016
New	1579 sf sfr with 1558 sf finished lower floor and 774 sf finished basement -	2012 IRC				2016
New	Approved basic 14-107587 BP	2012 IRC	Plan# Harvest	2-story sfr w/attached g		2016
New	New (2017) 32 x 70 Skyline ACKW910124JBA					2016
New	Approved basic 15-107753 BP	2012 IRC	Plan# 2265	Rambler w/attached garage		2016
New	Approved 14-107708 BP	2012 IRC	Plan# Stevens	2-story sfr w/attached gara		2016
New	Approved basic 14-107587 BP	2012 IRC	Plan# Harvest	2-story sfr w/attached g		2016
New	2419 square foot SFR					2016
New	1801 s.f. rambler w/attached garage					2016
New	Two story 3 BR SFR with attached garage.					2016
New	New 2-story SFR, 4,585 SF, 735 SF garage, 360 covered deck and 400 sf of uncovered deck					2016
New	Two-story 3 BR SFR note: affidavit to transfer from Free to Suyama 08-09-2016 jrlenz					2016
New	Two story SFR with attached garage.					2016
New	2 story sfr w/attached garage					2016
New	Two story SFR with attached Garage					2016
New	New 1,895 sf 2-story SFR with 469 sf garage and 85 sf covered porch					2016
New	Residential permit to relocate SFR to this site. Structural requires foundation, plumbing and HVAC					2016
New	Extended 30 days. If not finalized by July 1, 2018 will need to extend.			3,372 sf rambler with an a		2016
New	2264 .f. rambler w/attached garage					2016
New	Approved basic 16-100050 BP	2012 IRC	Plan# LDMR1	3-story sfr w/atta		2016
New	Approved basic 16-100050 BP	2012 IRC	Plan# LDMR1	3-story sfr w/atta		2016
New	Approved basic 16-100050 BP	2012 IRC	Plan# LDMR1	3-story sfr w/atta		2016
New	Approved basic 16-100050 BP	2012 IRC	Plan# LDMR1	3-story sfr w/atta		2016
New	SFR w/daylight basement and attached garage					2016

Accessory Dwelling Units

Index # - File Name: 1.0022 - Single Family Dwellings Data\_Snohomish County.pdf

New	New 2- story SFR with attached garage					2016
New	New 2- story SFR with attached garage					2016
New	Two-story 4 bedroom SFR with attached garage, covered porch and deck					2016
New	new 4 BR, 2-story SFR with attached garage and covered porch					2016
New	Rambler with attached garage					2016
New	2170 square foot SFR with attached Garage					2016
New	Rambler style sfr w/attached garage and bonus above					2016
New	New rambler style SFR with attached garage			SEE: 16-103369-LDA		2016
New	Two story SFR with attached Garage					2016
New	Manufactured home permit: 2016 single wide mobile home, Marlette (FP-1456A) 15 x 56ft					2016
New	804 sf detached accessory apartment with 300 sf carport attached and 216 sf covered porch					2016
New	Two Story SFR with Attached Garage					2016
New	Two story SFR with attached Garage					2016
New	Approved basic 16-114825 BP	2015 IRC	Plan# 2574 A	2 story sfr w/attache		2016
New	2 story sfr w/attached garage					2016
New	2 story sfr w/attached garage					2016
New	Approved basic 16-114825 BP	2015 IRC	Plan# 2574 A	2 story sfr w/attache		2016
New	New 2,545 sf rambler with 782 sf garage, 31 sf covered porch, and 150 sf deck					2016
New	One story SFR with attached Garage					2016
New	New 2909 sf 2-story SFR with 346 sf of covered area					2016
New	3 story sfr with attached garage	2015 IRC				2016
New	New 4,994 sf 2-story SFR with 699 sf garage and 316 sf covered deck/porch *NSF Check - Accep					2016
New	27 X 52 Triple-wide Mobile Home					2016
New	Two story SFR with finished Basement & attached Garage					2016
New	SFR: new 2 story home with attached garage, 4 bedroom/4 bathrooms					2016
New	Description of Work: set-up of MH in serene terrace mobile home park					2016
New	SFR: new 2 story home with 4 car attached garage, 4 bedrooms, 2.5 baths, main floor den, 2nd f					2016
New	846 s.f. single family residence w/2354 s.f. attached garage/shop					2016
New	2-story sfr w/attached garage					2016
New	Approved basic 15-107154 BP	2012 IRC	Plan# 3656 Daylight	Rambler styl		2016
New	2-story sfr w/attached garage					2016
New	New 2-story SFR with attached garage.			SEE: 15-117-388LDA		2016
New	New 4,142 sf 2-story SFR with 696 sf garage, 264 sf covered deck, and 360 sf deck					2016
New	New 2,760 sf rambler with 486 sf garage and 293 sf covered porch					2016
New	Approved basic 15-110223 BP	2012 IRC	Plan# EC-5D	2-story sfr w/attached gara		2016
New	New home: rambler style SFR with 3 car attached garage, covered front porch and covered (12 )					2016
New	Cont. work on expired for new SFR					2016
New	7/13/18 kam - Have advised Brandon w Agnew Homes, this permit has been expired for more th					2016
New	SFR: new home, rambler style with finished basement and attached 3 car garage, 3 bedroom wi					2016
New	1826 square foot SFR with 555 square foot attached Garage					2016
New	Plans revised following LDA review comments - New 3,386 sf 2-story sfr, with 660 sf garage and					2016
New	New 2-story 1,982 sfr with 253 sf covered deck and 284 sf deck					2016
New	Rambler style sfr w/attached garage					2016
New	Convert existing temporary dwelling mobile home to accessory apartment (27 x 67 2002 Valley					2016
New	SFR, 2-story style home with attached garage. 4 bedrooms 4.5 baths, covered front and back po					2016
New	New 2-story SFR 3978 sf w/1042 sf garage, 272 sf covered deck Revisising building plan under 1					2016
New	New 4,415 sf 2-story sfr with 1,657 sf garage, 1,287 sf unheated storage and 562 sf of covered d					2016

Accessory Dwelling Units

Index # - File Name: 1.0022 - Single Family Dwellings Data\_Snohomish County.pdf

New	2158 s.f. rambler w/attached garage	2016
New	24 x 52 1979 WSTRG	2016
New	SFR: new 2 bedroom, 2 bath home with attached garage and covered porch, 2nd floor unfinishe	2016
New	1560 s.f. rambler w/attached garage	2016
New	Rambler style sfr w/attached garage	2016
New	New 27 x 60 2016 Marlette Cornerstone	2016
New	Double-Wide Marlette / Cornerstone Mobile Home	2016
New	2015 27 X 56 Mobile Home	2016
New	New 27 x 48 2016 Fleetwood Waverly Crest	2016
New	New Double-wide, 27 x60	2016
New	New 27 x 64 2016 Marlette First Edition	2016
New	27 X 64 2016 Double Wide Mobile Home	2016
New	Description of Work: set-up of new mobile home in MH Park.	2016
New	large 3 BR rambler with attached garage, carport, covered porch and uncovered deck	2016
New	single story 3-BR SFR with attached garage	2016
New	New 672 sf detached accessory apartment with 144 sf covered porch	2016
New	New 27 x 68 Westridge CT by Skyline	2016
New	New 27 x 67 1998 Brookwood	2016
New	New 1904 sf SFR with 483 sf garage	2016
New	4 BR SFR with daylight basement and main floor above with attached garage with covered porchl	2016
New	1704 s.f. SFR w/1083 s.f. daylight basement sfr w/attached garage	SEE: 15-11 2016
New	2681 square foot SFR with attached Garage	2016
New	3,853 SF one-story SFR with attached garage Engineered by Roland Heimisch, P.E. 42479	2016
New	New 2-story SFR w/ attached garage	SEE: 16-114820-LDA & 16-1148: 2016
New	Approved basic 15-114843 BP 2012 IRC Plan# 3271 2-story sfr w/attach	2016
New	1809 square foot SFR with 1017 square foot unfinished Basement with attached Garage	2016
New	New 2-story 3,948 sf SFR with 1,198 sf garage and 116 sf covered porch	2016
New	New 2514 sf house with 193 of deck	2016
New	Originally Built without Permit 1410 square foot SFR with 1410 square foot Unfinished Basemen	2016
New	New 1926 sf rambler with 1056 sf garage and 312 sf covered porch	2016
New	1308 square foot SFR with attached Garage	2016
New	Permit for accessory apartment built without the required permits	2016
New	Two story SFR with wrap-around covered porch	2016
New	2 story sfr w/finished unfinished basement	2016
New	Two story SFR with attached Garage	2016
New	990 sf double-wide guesthouse	2016
New	Two Story SFR with attached Garage	2016
New	2 story sfr w/attached garage	2016
New	2-story SFR with attached garage	SEE: 15-115853-LDA 2016
New	SFR, 2 story style home with attached 2 car garage and covered front porch, 3 bedrooms 2.5 bai	2016
New	2320 square foot attached Garage	2016
New	4 BR two-story SFR with attached garage and covered porch	2016
New	Demo old SFR and build new 2 story SFR with attached garage	2016
New	2,967 square foot SFR with attached 830 square foot garage.	2016
New	two-story 4 BR SFR with attached garage	2016
New	2 story sfr w/attached garage	2016
New	SFR: new home with attached garage, lower daylight basement is garage and upper floor is mair	2016



Accessory Dwelling Units

Index # - File Name: 1.0022 - Single Family Dwellings Data\_Snohomish County.pdf

New	2 story sfr w/attached garage				2016
New	2-story sfr w/attached garage	sq. footage updated to reflect alteration: see child 17-105927 RK			2016
New	2145 sq ft Rambler with 930 sq ft Attached Garage and 498 sq ft Covered Porch				2016
New	Approved basic 15-102227 BP	2012 IRC	Plan# 1292-duplex	2-story duplex	2016
New	New 1200 sf 2-story sfr w/400 sf garage, 27.5 sf covered porch, and 64 sf deck				2016
New	New 1200 sf 2-story sfr w/400 sf garage, 27.5 sf covered porch, and 64 sf deck				2016
New	Approved basic 15-102257 BP	2012 IRC	Plan# 1433	2-story sfr w/attached ga	2016
New	Approved basic 15-102257 BP	2012 IRC	Plan# 1433	2-story sfr w/attached ga	2016
New	Approved basic 15-102257 BP	2012 IRC	Plan# 1433	2-story sfr w/attached ga	2016
New	New 2 story SFR w/ attached garage			SEE: 16-100464-LDA	2016
New	New rambler style SFR w/ attached garage			SEE: 16-1	2016
New	New 3,057 sf 2-story SFR with 396 sf garage and 225 sf covered porch				2016
New	Replacing existing MH with Two story SFR with attached Garage in same footprint				2016
New	New 2,104 sf 1-story w/basement SFR				2016
New	2 story sfr w/attached garage replacing existing mobile home.				2016
New	New 2- story SFR w/ attached garage				2016
New	2 story sfr w/attached garage				2016
New	New 2-story SFR with attached garage and covered deck replacing existing MH and garage TBR				2016
New	Rambler with attached garage				2016
New	Two story SFR with attached Garage & Carport				2016
New	2 story duplex w/attached garage				2016
New	Approved basic 15-103889 BP	2012 IRC	Plan# 1561-duplex	2-story duplex w/attached 2 c	2016
New	SFR: residential building permit for construction of new 2 story style home with attached 3 car g				2016
New	2709 rambler w/attached garage			SEE:16-119364-LC	2016
New	Approved basic 13-110975 BP	2012 IRC	Plan: Flagstaff	Two-story SFR with 245 sf k	2016
New	SFR, 2 story home with attached 2 car garage and wrap around covered porch				2016
New	Rambler style sfr w/attached garage				2016
New	SFR: new 2 story home with attached 3 car garage and wrap around covered porch				2016
New	Two story SFR with attached garage and covered porch plus patio				2016
New	2703 square foot SFR w/attached Garage				2016
New	New 2-story SFR w/ attached garage			SEE: 16-	2016
New	SFR: new rambler style home with attached 3-car garage, 3 bedroom, 2 bath				2016
New	New 1308 sf rambler with 400 sf garage, 15 sf covered porch				2016
New	2 story sfr w/attached garage				2016
New	Construct 336 SF patio cover over existing concrete patio				2016
New	New garage/expansion of existing garage and moving laundry/bathroom to new space				2016
New	SFR: 2 - story style home with 3 bedrooms, a den, 2.5 baths and attached 2 car garage				2016
New	Two story 2 bedroom SFR with covered porch and attached garage previous RK withdrawn (15-				2016
New	Two story 3 bedroom SFR with attached garage and covered porch				2016
New	Residential building permit to legalize the (existing) detached accessory building/ apartment (co				2016
New	New 1,784 2-story residence with 355 sf garage ***Approved structural plans are flipped, howe				2016
New	1200 square foot SFR with attached Garage				2016
New	3 BR two-story SFR with attached garage and small covered deck				2016
New	773 SF ADU with attached 360 SF shop			SEE: 16-106592-ACUP & 16-1065	2016
New	2 story sfr w/attached garage				2016
New	New 670 sf sfr above 728 sf garage				2016
New	SFR, rambler with basement and attached garage, 4 bedrooms 3 baths				2016

Accessory Dwelling Units

Index # - File Name: 1.0022 - Single Family Dwellings Data\_Snohomish County.pdf

New	2-story sfr w/daylight basement w/attached garage				2016
New	2-story sfr w/daylight basement w/attached garage				2016
New	2-story sfr w/daylight basement w/attached garage				2016
New	Converting Crawl Space into Unfinished Basement				2016
New	Rambler style sfr w/attached garage and unfinished basement				2016
New	New 2- story SFR w/ attached garage (old SFR demolished under separate permit)				2016
New	New SFR, approved basic plan 14-107790-BP				2016
New	2 story duplex w/attached garage				2016
New	New SFR with 2,305 sf main and 2,280 unfinished basement, 1130 sf garage and 876 sf of c				2016
New	New 2016 40 x 70 Cedar Canyon LS				2016
New	New double wide MH	KIT 2504		2016	3
New	Approved basic 13-101858 BP	2009 IRC	Plan# 2200	2-story sfr w/attached }	2016
New	Approved basic 16-100935 BP	2012 IRC	Plan# 2060 (38# snow)	2-story sfr w/at	2016
New	Approved basic 13-101858 BP	2009 IRC	Plan# 2200	2-story sfr w/attached }	2016
New	Approved basic 16-100935 BP	2012 IRC	Plan# 2060 (38# snow)	2-story sfr w/at	2016
New	3410 s.f. rambler w/attached garage				2016
New	Two story SFR with attached Garage				2016
New	SFR: 2 story with 3 bedrooms and 2.5 baths with attached 2 car garage --- Contacted Kim Peters				2016
New	New 3,573 sf 2-story home with 757 sf of deck				2016
New	2016 26 8 X 48 Double-wide Mobile Home				2016
New	Two story 4 BR with attached garage				2016
New	1836 SF Rambler with 347 SF Attached Garage and 37 SF Covered Porch				2016
New	New 2,306 sf rambler with 793 sf garage and 633 sf of covered deck				2016
New	2 story SFR with CAS			SEE:16-10034	2016
New	Single Story SFR with attached garage and covered porch				2016
New	Existing 66 x 28 1990 Fleetwood Original permit expired 6/13/91 w/o inspection				2016
New	2 story w/finished basement and attached garage				2016
New	Manufactured Home Permit: 2001 double wide MH, 27 x 66				2016
New	Demolish existing SFR and rebuild new in same footprint				2016
New	Manufactured Home: 2016 double wide, Marlette 26 -8 x 60				2016
New	4 bedroom rambler with finished basement and attached garage Engineered by Gregory S. Mill				2016
New	2442 s.f. rambler w/attached garage				2016
New	3,593 SF 2-story SFR with attached garage. Engineered by Frank T. Jarnot, P.E. 25746				2016
New	New 20 x 42 2016 Marlett Cornerstone 2442A				2016
New	15 X 56 Single Wide MH				2016
New	New rambler style SFR with attached garage			SEE: 16-1	2016
New	2-story sfr w/attached garage				2016
New	New 3 BR SFR built w/o permits				2016
New	Demo old SFR and build new 1450 SF rambler style SFR.				2016
New	Extended 30 days, if not finaled by July 8, 2018 will need to renew. Single Story sfr with attache				2016
New	New 2017 41 x 70 Skyline Westridge 1271Ct				2016
New	SFR: new rambler with attached garage and covered porch. 3 bedrooms 2.5 bath				2016
New	SFR: rambler style home 3 bedrooms/2 baths (no garage)				2016
New	New 1922 sf rambler with 588 sf garage and 255 sf covered porch				2016
New	New rambler style SFR with attached garage			SEE:	2016
New	2607 square foot SFR with attached Garage				2016
New	3 BR rambler with attached garage and covered porch				2016

Accessory Dwelling Units

Index # - File Name: 1.0022 - Single Family Dwellings Data\_Snohomish County.pdf

New	1818 square foot Rambler with attached Garage	2016
New	New 2,172 sf 1-story garage with 1,200 sf garage and 240 sf covered porch and 200 sf deck	2016
New	Golden State Kit Triple Wide MH	2016
New	Skyline Westridge 70 X 30 2016 SEE: 16-1086	2016
New	SFR, rambler style home, 2 bedroom/2 bath (ref. pre-appl 16-100846 PA)	2016
New	2017 14 x 56 Roseburg by Skyline Single Wide Mobile Home	2016
New	1336 square foot Rambler with attached Garage	2016
New	New 1,615 sf SFR with 65 sf of deck Glacier Peak Volcanic Hazard Disclosure Notice Recorded 7-	2016
New	New 2-story SFR w/basement, 2,377 sf with 104 sf sunroom	2016
New	Demolish old garage and build / New 1,027 sf detached garage w/ 384 sf of heated space for an	2016
New	2 story single family residence no garage	2016
New	New 2- story SFR	2016
New	SFR: Rambler style with bonus space over 3 car attached garage	2016
New	Two story SFR wtih attached garage	2016
New	2 story sfr w/attached garage	2016
New	Two story, 4 bedroom SFR with attached garage and covered porch.	2016
New	Temporary Dwelling 26 - 8 x 56 2016 Valley Cottage 2804	2016
New	3074 sq ft SFR with 802 sq ft Garage	2016
New	2- story SFR w/ attached garage SEE: 15-1196:	2016
New	27 x 64 2015 Goldenwest	2016
New	2 story SFR with attached garage. 2015 IRC code	2016
New	204 s.f. Detached Exercise Room	2016
New	Two story SFR with finished Basement and attached Garage	2016
New	Approved basic 16-100774 BP 2009 IRC Plan# 2200 (38# snow) 2-story sfr	2016
New	Convert ex. double wide trailer to stick built A framed style cabin (permit to resolve violation 15	2016
New	SFR: new rambler style home with attached 2 car garage, 3 bedroom 1.75 bath	2016
New	Two BR SFR with deck and unfinished basement	2016
New	1736 square foot SFR with attached Garage CASP AF: 201607290721	2016
New	Rambler with attached garage and covered deck/porch.	2016
New	New 3,195 sf 1-story SFR w/basement, 888 sf garage and 568 sf covered deck	2016
New	Approved basic 16-100775 BP 2012 IRC Plan# 2254 (38# snow) 2-story sfr w/a	2016
New	2259 square foot SFR with attached 819 square foot Garage	2016
New	464 sq ft Deck	2016
New	SEE:15-115156-LDA ****Plans revised on 2/26/16****650 sf SFR above 3000 sf garage and	2016
New	Two story Duplex with attached Garages	2017
New	Single story sfr with attached garage 2015 IRC	2017
New	New 2,429 sf 2-story SFR with 890 sf garage and 484 sf covered porch 30-day extension one tim	2017
New	2575 square foot SFR with 2497 square foot unfinished Basement and attached Garage	2017
New	Converting crawl space into finished Basement One time 30 day extension tjr	2017
New	2017 27 X 69 5 double-wide Metolious Cabin Mobile Home	2017
New	New 2,268 SF SFR with 729 SF attached garage and 362 SF covered deck. (1993 MH already r	2017
New	2028 square foot SFR with attached Garage	2017
New	Expiration date extended 120 days per Emergency Ordinance 20-027 430 square foot SFR with 2	2017
New	Two story SFR with attached Garage	2017
New	This application was sent a notice of pending application expiration on April 11, 2017, and will e	2017
New	New 1-story w/bsmt SFR; 2,333 sf main floor, 1180 finished basement, 1236 uf basement, 1149	2017
New	New 1-story SFR w/basement; 2,363 sf main floor, 965 sf of finished basement, 1481 sf of unfini	2017

Accessory Dwelling Units

Index # - File Name: 1.0022 - Single Family Dwellings Data\_Snohomish County.pdf

New	SFR: rambler style home with attached 2 car garage	2017
New	New 1,665 sf SFR with 1180 garage area and 1460 sf recreation space and a 625 sf covered porch	2017
New	New 850 sf SFR above 2,496 sf garage with 533 sf covered porch	2017
New	Approved Basic 17111258BP 2015 IRC PLAN: 3168 3168sf two story SFR with	2017
New	New SFR	2017
New	Two story SFR with finished Basement and attached Garage	2017
New	Approved basic 13-110770 BP 2012 IRC Plan: 2364 Two-story SFR with attached garage	2017
New	2 story sfr w/attached garage	2017
New	New 2,692 sf SFR with 660 sf garage and 1288 sf covered porch	2017
New	New 2-story, 2,002 SF SFR with 440 SF attached garage and covered deck. 14-110710 LDA approved	2017
New	2546 square foot SFR	2017
New	New 2,556 sf 1-story w/basement SFR, 1020 sf garage, 636 sf deck and 60 sf covered porch	2017
New	New 2573sf SFR with 700sf attached garage, 475sf covered porch and new driveway.	2017
New	New 2,675 SF SFR with 1,150 SF garage and 441 SF covered deck	2017
New	2750 square foot SFR with 670 square foot unfinished Basement with 720 square foot attached garage	2017
New	***5/17/19 cst one time 30 day extension***Two story SFR with attached Garage	2017
New	2223 square foot SFR with attached Garage	2017
New	Declaration of Owner Occupancy AFN: 201707120403, Land Use Binder AFN: 201707120402 New	2017
New	840 square foot detached accessory apartment	2017
New	New 814 SF SFR.	2017
New	1845 s.f. rambler w/attached garage	2017
New	New 2,219 sf 2-story SFR with 565 sf garage and 475 sf storage above	2017
New	Expiration date extended 120 days per Emergency Ordinance 20-027 New SFR -Customer pickin	2017
New	New single wide mobile home. To be temporary dwelling during the construction of future SFR.	2017
New	2500 s.f. rambler w/attached garage	2017
New	Extended an extra 30 days. Two story SFR with 956 square feet unfinished Basement and 624	2017
New	New SFR 30 day extension given SCDERD	2017
New	Expiration date extended 120 days per Emergency Ordinance 20-027 New 4,122 sf 2-story SFR v	2017
New	Two story SFR with attached Garage	2017
New	New SFR with attached garage. 68 x 62, 2100 square feet, 4 bedrooms	2017
New	Volcanic Hazard AFN: 201710200111 Airport Disclosure AFN: 201710200110 3253 square foot	2017
New	New 1-story w/basement: 2,447sf finished space main floor, 485 sf unfinished bonus above garage, 812	2017
New	New 2,230 SF SFR with 524 SF attached garage with covered deck. Existing mobile home to be removed	2017
New	2342 square foot SFR no garage	2017
New	2223 rambler w/attached garage	2017
New	Replacing a fire destroyed SFR with a Two story SFR 30 day extension has been given on Feb 8 2	2017
New	New 1,516 sq. ft. SFR with 1,728 sq. ft. attached garage with 1,650 sq. ft. loft.	2017
New	2 story A frame sfr no garage	2017
New	New single family residence	2017
New	New 2-story, 3,793 SF SFR with 600 SF attached garage. SEE: 15-107	2017
New	New 3,892 sq. ft. SFR with 672 sq. ft. garage and 334 sq. ft. deck and 54 sq. ft. covered porch.	2017
New	New 2380 sq. ft. SFR with 204 sq. ft. covered deck 30 Day Extension Given on 11-30-18 ERD	2017
New	Expiration date extended 120 days per Emergency Ordinance 20-027 SFR: rebuild ex. cabin, (mir	2017
New	New Single Story SFR with attached garage	2017
New	Install new Double-wide MH and driveway	2017
New	Expiration date extended 120 days per Emergency Ordinance 20-027 single story sfr with attached	2017
New	New 2,160 SF, 2 story with unfinished basement and covered deck SFR.	2017

Accessory Dwelling Units

Index # - File Name: 1.0022 - Single Family Dwellings Data\_Snohomish County.pdf

New	New 1,800 square foot residence with 40 square foot covered porch (updated impervious 8/4/1	2017
New	Approved Basic 16-115219 BP 2015 IRC Plan# 2165 2-story SFR w/ attached ga	2017
New	New 54 X 42 Single Family Residence	2017
New	Continued work on 14-107637 RK (Permit fee 30% - framing already inspected) SFR, two story	2017
New	New 2-story, 1,429 SF SFR built on existing foundation. Demolishing existing SFR and rebuilding	2017
New	New 26 8 x 76 mobile home. (Existing mobile already removed)	2017
New	SFR: rambler style with attached garage, two bedrooms	2017
New	Approved Basic 16-118940 BP 2015 IRC Plan #2183-GR 2 story single family h	2017
New	2 Story SFR w/attached garage	2017
New	New 28 x 48 double wide MH (built in 1988) to move into compliance with 16-102401 CT. Dec	2017
New	Rambler style sfr w/attached garage	2017
New	Convert existing SFR into a Duplex	2017
New	New 2-story 3,587 SF SFR with attached 2-story 923 SF garage (2nd story storage), and attached	2017
New	New 3,154 sq. ft. SFR with 888 sq. ft. garage and 328 sq. ft. of covered porch/decks	2017
New	2 story duplex with 4 bedrooms in each unit, 2 car garage for each unit 2015 IRC	2017
New	New 2-story 3,926 SF duplex with 920 SF attached garages and covered porches.	2017
New	New 2 story 3,948 SF duplex with 796 SF garages (398 SF each) and covered decks.	2017
New	Duplex w/attached garage	2017
New	2017 15 X 60 Single-wide Mobile home	2017
New	New 2,833 sf 2-story SFR with 336 sf garage and 1,264 sf covered porch	2017
New	1490 s.f. rambler w/attached garage	2017
New	New 2430 SFR, 848sf attached garage, 52sf covered deck, and 100sf deck. Revised site and buil	2017
New	2268 sq. ft. single family sfr with attached garage, demolish existing storage 2015 IF	2017
New	SFR: two story home with attached 2 car garage Issue with related permits 16-119419 AB and 1	2017
New	2325 s.f. single family residence w/1624 s.f. garage & 775 s.f. heated storage	2017
New	2 story sfr with attached garage 2015 IRC **Lower level conditione	2017
New	SFR: new 2 story style home, 3 bedrooms, 3 baths	2017
New	New 3,023 SF SFR with attached 730 SF garage and decks.	2017
New	Duplex: rambler style with attached garages, 3 bedrooms 2 baths each side, unit A & B	2017
New	Rambler with attached garage 2015 IRC (REF 16-115097 ACUP)	2017
New	New 2017 28 x 60 2860 Marlette Special	2017
New	Construction of 2860 sq. ft. garage and attached 840 sq. ft apartment ***30 day extension give	2017
New	New 2-story, 2,538 SF SFR with 703 SF attached garage, and 200 SF covered deck, 119 SF deck.	2017
New	2-story, 5,258 SFR with 1,065 attached garage and unfinished basement. (Existing barn house, g	2017
New	Replacing Mobile Home with 1920 square foot SFR & 1882 square foot Deck	2017
New	New 3 story (including finished basement) 4,011 SF SFR with 689 SF attached garage, 126 SF cov	2017
New	Land use permit binder AFN: 201711160329 Permit to convert garage to a 650 sq. ft. attached /	2017
New	2525 sf SFR with 1569 sf unfinished basement	2017
New	30 day extension 4/12/19 esp New 2550 sf SFR	2017
New	1988 double wide, Eaton, 28 x 60 Mobile home. Originally placed in 1988 without benefit of a	2017
New	2017 Marlette Patriot 28x56 mobile home.	2017
New	2 story sfr w/attached garage	2017
New	Convert existing covered porch to living space	2017
New	Replacing existing SFR with Two story SFR with attached Garage in same foot print	2017
New	Declaration of Owner Occupancy AFN: 201708010475, Land Use Permit Binder AFN: 201708010	2017
New	Approved Basic 16-113810 BP 2015 IRC Plan # Interurban Revis	2017
New	2110sf SFR with attached garage. Lot 1.	2017

Accessory Dwelling Units

Index # - File Name: 1.0022 - Single Family Dwellings Data\_Snohomish County.pdf

New	2 story sfr w/attached garage	2017
New	New 2-story SFR	2017
New	2172 square foot SFR with attached Garage	2017
New	New 3,326 2-story SFR with 56 sf covered porch 201706070255 Landslide Hazard	2017
New	Approved basic 16-114080 BP 2015 IRC Plan# 2974 2-story sfr w/attached }	2017
New	New 1,555 SF SFR with 429 SF attached garage and 900 SF covered deck. Existing MH to be re	2017
New	New 2-story 3,567 SF SFR with 924 SF garage and covered deck/deck. Existing mobile home on	2017
New	SFR: new rambler with attached 2-car garage, 3 bedrooms + office, 2 1/2 baths	2017
New	Expiration date extended 120 days per Emergency Ordinance 20-027 New 3262 square foot sing	2017
New	New 2-story, 2,715 SF SFR with 879 SF attached garage.	2017
New	1345 square foot SFR with 404 square foot attached Garage. Replacing an existing MH in the sa	2017
New	New 2-story, 1,336 SF SFR with 489 SF attached garage, 60 SF covered deck, and 18 SF uncover	2017
New	New 2-story, 1,336 SF SFR with 489 SF attached garage, 60 SF covered deck, and 18 SF uncover	2017
New	New 2828 sq. ft. SFR with 506 sq. ft. garage, 40 sq. ft. covered porch, and 533 sq. ft uncovered c	2017
New	New 2,306 sf 2-story SFR with 453 sf garage and 160 sf covered porch	2017
New	440 square foot detached Garage with 440 square foot second floor Workshop	2017
New	New 2,665 SF 2-story SFR with 555 SF attached garage and 85 SF covered porch. Existing MH	2017
New	Two story SFR with attached Garage	2017
New	Two story SFR with unfinished Basement and attached Garage	2017
New	New 480 SF detached accessory apartment	2017
New	834 square foot Detached Accessory Apartment with 735 square foot Garage with 2nd story 73!	2017
New	Pending Basic 17-103232 BP 2015 IRC Plan# 1433 (35#snow) 2 story	2017
New	1248 square foot SFR	2017
New	2 story sfr w/attached garage	2017
New	New Duplex	2017
New	2 story sfr with attached garage 2015 IRC	2017
New	3064 s.f. rambler w/attached garage	2017
New	CASP AFN: 201706160252 2018 27 x 58 double wide MH	2017
New	SFR: new 2 story home with attached 3 car garage, 4 bedrooms plus office and bonus rooms	2017
New	Two story SFR with attached Garage	2017
New	New 3082 sq ft SFR with 625 sf attached garage	2017
New	Expiration date extended 120 days per Emergency Ordinance 20-027 New 4,450 sf 3-story SFR v	2017
New	New 2,318 sf 2-story SFR with 686 sf garage	2017
New	Two story SFR with attached Garage Engineered by A. Blaze Bresko, P.E. 31728	2017
New	698 square foot detached Accessory Apartment	2017
New	1048 s.f. sfr w/488 s.f. basement & 465 s.f. attached garage	2017
New	Two story SFR with attached Garage	2017
New	New 4,882 sq. ft. SFR with 1,122 sq. ft. garage and 1,114 sq. ft. covered porch and 180 sq. ft. un	2017
New	2 story sfr with attached garage	2017
New	New 2-story SFR with attached garage and covered porches. Bldg dimensions approx. 55 x 52	2017
New	New 3,293 sf SFR with 672 sf garage and 301 sf covered porch	2017
New	Expiration date extended 120 days per Emergency Ordinance 20-027 Two story SFR with attach	2017
New	New 2128 sq ft single story SFR with patio, covered porch and attached garage. ****Check acc	2017
New	New 28 X 56 mobile home.	2017
New	New 800 square foot single-story SFR	2017
New	Manufactured Home: 2017, Double wide Marlette Mobile, 27 x 56	2017
New	New 3,476 sf 2-story sfr, 832 sf garage, with 384 sf covered porch	2017

Accessory Dwelling Units

Index # - File Name: 1.0022 - Single Family Dwellings Data\_Snohomish County.pdf

New	New 1,728 sq. ft. SFR with 484 sq. ft. garage and 192 sq. ft. covered porch. - Fee have been crea	2017
New	Approved Basic 16-113810 BP 2015 IRC Plan # Interurban Revis	2017
New	New 2 story sfr with unfinished basement and attached 3 car garage 2015 IRC	2017
New	2160 square foot SFR with 4300 square foot Barn & Shop on lower level	2017
New	Approved Basic 16-118940 BP 2015 IRC Plan #2183-GR 2 story single family h	2017
New	CASP AFN: 201705240529 Approved basic 16-118177 BP 2015 IRC Plan# 2	2017
New	Approved basic 16-118177 BP 2015 IRC Plan# 2370 2-story sfr w/	2017
New	Expiration date extended 120 days per Emergency Ordinance 20-027 New SFR	2017
New	2017 27 X 56 Double-wide Mobile Home Permit	2017
New	New 2,462 sq. ft. SFR with 470 sq. ft. garage	2017
New	Two story SFR with attached Garage	2017
New	Duplex: 2 story style, with attached garages	2017
New	CASP AFN:201705240717 & Notice Right to Practice Forestry AFN: 201705240716 2 story sfr w,	2017
New	2 story SFR with finished basement and attached garage SEE: 16-1155	2017
New	single story sfr with attached garage	2017
New	New 3000 sf SFR with partially finished basement and attached garage	2017
New	New 2,476 sf rambler with 775 sf garage	2017
New	Expiration date extended 120 days per Emergency Ordinance 20-027 Permit to get final on expi	2017
New	New 30 x 60 double wide MH. (Breezeway and garage to be applied for at a future date)	2017
New	Approved Basic 16-115219 BP 2015 IRC Plan# 2165 2-story SFR w/ attached ga	2017
New	New 2017 Cedar Canyon double wide	2017
New	Expiration date extended 120 days per Emergency Ordinance 20-027 Two story SFR with unfinis	2017
New	Approved basic 16-118177 BP 2015 IRC Plan# 2370 2-story sfr w/	2017
New	New 2-story SFR with attached garage and covered porches. Approx bldg. dimensions 68 x 45	2017
New	2356 sq ft SFR with 1506 sq ft Finished Basement with attached Garage	2017
New	New 2,996 sf 2-story SFR with 358 sf garage and 106 sf deck	2017
New	SFR: rambler style home with attached garage, 3 bedrooms, 2.5 baths	2017
New	New rambler style SFR w/attached garage	2017
New	Duplex: new, 2 story with attached garages, 4 bedrooms & 2.5 baths per unit	2017
New	New 2,523 sf 2-story SFR with 528 sf garage connected by breezeway	2017
New	1999 27 x 44 Fleetwood	2017
New	1904 Square Foot SFR with attached Garage Engineered by Damon S. Fleming, P.E. 42771	2017
New	New 2017 Majestic triple-wide MH	2017
New	New 2017 Green Acres Double Wide for Warm Beach Senior Community Lot 7	2017
New	Rebuild fire damaged duplex, 3 story duplex with elevator, shared entry foyer, wheel chair ramp	2017
New	Two story 3 BR SFR with attached garage with two deck areas	2017
New	1907 square foot SFR	2017
New	New 2,621 SF SFR with 658 SF attached garage and 282 SF attached covered porch. Existing MH	2017
New	2 story sfr w/attached garage	2017
New	2 story w/attached garage	2017
New	Approved Basic 16-113810 BP 2015 IRC Plan # Interurban Revised 2 story singl	2017
New	2 story sfr w/attached garage	2017
New	2 story w/finished basement and attached garage	2017
New	2 story w/finished basement and attached garage mark ups retrieved 03/31/2017 CD	2017
New	2 story sfr w/attached garage RSP approved 2/1/18	2017
New	New 3,001 SF, 2-story SFR with 720 SF attached garage and 197 SF covered porch.	2017
New	New two story 1339 SF SFR	2017

Accessory Dwelling Units

Index # - File Name: 1.0022 - Single Family Dwellings Data\_Snohomish County.pdf

New	841 sq. ft. detached accessory apartment with 257 sq. ft. garage with 310 sq. ft. uncovered deck				2017
New	New 2,799 sf 2-story SFR with 572 sf garage and 92 sf covered porch				2017
New	Two story SFR with Finished Basement and attached Garage				2017
New	Approved basic 17-101246 BP	2015 IRC	Plan# 3017	2-story sfr w/attached g	2017
New	Approved basic 17-101246 BP	2015 IRC	Plan# 3017	2-story sfr w/attached g	2017
New	Approved basic 17-101245 BP	2015 IRC	Plan# 2972	2-story sfr w/attached g	2017
New	Approved basic 16-121633BP	2015 IRC	Plan# 2458	2-story sfr w/attached g	2017
New	Approved basic 17-101245 BP	2015 IRC	Plan# 2972	2-story sfr w/attached g	2017
New	Approved basic 17-101246 BP	2015 IRC	Plan# 3017	2-story sfr w/attached g	2017
New	Approved basic 17-101506 BP	2015 IRC	Plan# 3049	2-story sfr w/attached g	2017
New	Approved basic 17-101506 BP	2015 IRC	Plan# 3049	2-story sfr w/attached g	2017
New	Approved basic 16-121633BP	2015 IRC	Plan# 2458	2-story sfr w/attached g	2017
New	Approved basic 17-101248 BP	2015 IRC	Plan# 3656	2-story sfr w/attached g	2017
New	Approved basic 17-101248 BP	2015 IRC	Plan# 3656	2-story sfr w/attached g	2017
New	Two story SFR with Attached Garage				2017
New	Two story SFR with attached Garage				2017
New	New 2-story 3,069SF SFR with 819 SF attached garage and 317 SF covered deck. (432 SF of the s				2017
New	2194 s.f. sfr w/400 s.f. finished basement & attached garage				2017
New	2017 Marlette Patriot Double wide 27 x 56				2017
New	1815 square foot SFR with 910 square foot finished Basement with attached Garage				2017
New	Two story SFR with attached Garage				2017
New	New 4232 square foot SFR with attached Garage				2017
New	New 2-story SFR w/ attached garage			SEE: 16-	2017
New	New 4 bedroom, 1654 sq ft SFR with attached garage				2017
New	New 2,766 SF, 2-story SFR with 884 SF attached garage (11,575 SF clearing, 200 cy cut, 250 cy fil				2017
New	2 story sfr (no garage)				2017
New	New 2,640 2-story sfr w/basement, w/409 sf garage, 60 sf covered porch and 209 sf covered de				2017
New	Two story SFR with attached Garage				2017
New	1886 square foot SFR with 1168 square foot finished Basement & 660 square foot unfinished St				2017
New	2323 sf SRF with 636 attached garage and 36 sf covered porch				2017
New	Approved Basic 17-101928BP	IRC 2015	Plan # Stevens	89 x 53 2-story SFR	2017
New	2 story sfr w/attached garage				2017
New	SFR: 2 story style home with attached garage				2017
New	Approved Basic 17-101928BP	IRC 2015	Plan # Stevens	89 x 53 2-story SFR	2017
New	2 story sfr w/attached garage				2017
New	Permit for SFR after the fact This permit must be finalized prior to or simultaneously with 17-107				2017
New	2 story sfr w/attached garage				2017
New	2360 square foot SFR with 1484 square foot finished Basement with attached Garage				2017
New	New 2 story sfr with daylight basement with attached garage				2017
New	Expiration date extended 120 days per Emergency Ordinance 20-027 2762 sf sfr with 824 sf mai				2017
New	New 2,418 sf SFR with 728 sf attached garage, 471 sf covered porch, and 146 sf deck				2017
New	Two story SFR with attached Garage				2017
New	Two story SFR with attached Garage				2017
New	SFR: new rambler style home with attached 2 car garage and covered front porch, 3 bedroom 2.				2017
New	Two story SFR with attached Garage				2017
New	**Extended 30 days. Needs to be finalized by 10/03/2018 or will need to renew. Two story SFR				2017
New	New 2,506 sf SFR with 529 sf garage, 161 sf covered porch, 192 sf deck			SEE: 17-10	2017







Accessory Dwelling Units

Index # - File Name: 1.0022 - Single Family Dwellings Data\_Snohomish County.pdf

New	2 story w/attached garage				2017
New	2 story w/attached garage				2017
New	2 story w/attached garage				2017
New	2 story w/attached garage				2017
New	2 story w/attached garage				2017
New	Two story SFR with attached Garage				2017
New	2 story w/attached garage				2017
New	New 2,188 sq. ft. SFR with 436 sq. ft. garage and 82 sq. ft. covered porch.				2017
New	2 story w/attached garage				2017
New	2-story sfr w/attached garage				2017
New	2 story w/attached garage				2017
New	2 story w/attached garage				2017
New	2 story w/attached garage				2017
New	2 story w/attached garage				2017
New	2 story w/attached garage				2017
New	2 story w/attached garage				2017
New	2-story sfr w/attached garage				2017
New	SFR: 2 story with attached garage				2017
New	SFR: 2 story with attached garage				2017
New	2 story w/attached garage				2017
New	2 story w/attached garage				2017
New	2 story w/attached garage				2017
New	2 story w/attached garage				2017
New	2 story w/attached garage				2017
New	Approved basic 16-108063 BP	2012 IRC	Plan# 2435	2-story sfr w/basement &	2017
New	Approved basic 16-108063 BP	2012 IRC	Plan# 2435	2-story sfr w/basement &	2017
New	Approved basic 16-108063 BP	2012 IRC	Plan# 2435	2-story sfr w/basement &	2017
New	Approved basic 16-108063 BP	2012 IRC	Plan# 2435	2-story sfr w/basement &	2017
New	Approved basic 16-108063 BP	2012 IRC	Plan# 2435	2-story sfr w/basement &	2017
New	Approved basic 16-108063 BP	2012 IRC	Plan# 2435	2-story sfr w/basement &	2017
New	Approved basic 16-108063 BP	2012 IRC	Plan# 2435	2-story sfr w/basement &	2017
New	Approved basic 16-108063 BP	2012 IRC	Plan# 2435	2-story sfr w/basement &	2017
New	Approved basic 16-108063 BP	2012 IRC	Plan# 2435	2-story sfr w/basement &	2017
New	Approved basic 16-108063 BP	2012 IRC	Plan# 2435	2-story sfr w/basement &	2017
New	Approved basic 16-108063 BP	2012 IRC	Plan# 2435	2-story sfr w/basement &	2017
New	Approved basic 16-108061 BP	2012 IRC	Plan# 2515-2	2-story sfr w/attachec	2017
New	Approved basic 16-108062 BP	2012 IRC	Plan# 2384-2	2-story sfr w/attached	2017
New	Two story SFR with attached Garage				2017
New	Approved basic 14-108655 BP	2012 IRC	Plan# 2043	2-story sfr w/attached gar	2017
New	Approved basic 14-108655 BP	2012 IRC	Plan# 2043	2-story sfr w/attached gar	2017
New	Approved basic 14-108655 BP	2012 IRC	Plan# 2043	2-story sfr w/attached gar	2017
New	Approved basic 14-108655 BP	2012 IRC	Plan# 2043	2-story sfr w/attached gar	2017
New	Approved basic 14-108665 BP	2012 IRC	Plan# 1896	2-story sfr w/attached gar	2017
New	Approved basic 14-108655 BP	2012 IRC	Plan# 2043	2-story sfr w/attached gar	2017
New	Approved basic 14-108655 BP	2012 IRC	Plan# 2043	2-story sfr w/attached gar	2017
New	Approved basic 14-105837 BP	2012 IRC	Plan# 1782	2-story sfr w/attached ga	2017
New	Approved basic 14-108665 BP	2012 IRC	Plan# 1896	2-story sfr w/attached gar	2017

Accessory Dwelling Units

Index # - File Name: 1.0022 - Single Family Dwellings Data\_Snohomish County.pdf

New	Approved basic 14-108655 BP	2012 IRC	Plan# 2043	2-story sfr w/attached gar	2017
New	NEw 1842 sf rambler with 400 sf garage				2017
New	2 story sfr w/attached garage				2017
New	2 story sfr w/attached garage				2017
New	Two story SFR with attached Garage				2017
New	New 5,100 SF SFR with 1,300 SF attached garage. conditions revised 11-27-2017 jrlenz				2017
New	Approved basic 16-110704 BP	2012 IRC	Plan# 1856	2-story w/attache	2017
New	Approved basic 16-110704 BP	2012 IRC	Plan# 1856	2-story w/attache	2017
New	Approved basic 16-110704 BP	2012 IRC	Plan# 1856	2-story w/attache	2017
New	Approved basic 16-110712 BP	2012 IRC	Plan# 1608	2-story w/attache	2017
New	Approved basic 16-110712 BP	2012 IRC	Plan# 1608	2-story w/attache	2017
New	Approved basic 16-110712 BP	2012 IRC	Plan# 1608	2-story w/attache	2017
New	Approved basic 16-119384 BP	2015 IRC	Plan# 2552	2-story sfr w/base	2017
New	Approved basic 16-110709 BP	2012 IRC	Plan# 1795	2-story w/attache	2017
New	Approved basic 16-110704 BP	2012 IRC	Plan# 1856	2-story w/attache	2017
New	Approved basic 16-110700 BP	2012 IRC	Plan# 2417	2-story w/attac	2017
New	Approved basic 16-110700 BP	2012 IRC	Plan# 2417	2-story w/attac	2017
New	Approved basic 16-110700 BP	2012 IRC	Plan# 2417	2-story w/attac	2017
New	Approved basic 16-111086 BP	2012 IRC	Plan# 2607	2-story w/attach	2017
New	Approved basic 16-111208 BP	2012 IRC	Plan# 1536	2-story w/attache	2017
New	Approved basic 16-111208 BP	2012 IRC	Plan# 1536	2-story w/attache	2017
New	Approved basic 16-111087 BP	2012 IRC	Plan# 1708	2-story w/attache	2017
New	Approved basic 16-110709 BP	2012 IRC	Plan# 1795	2-story w/attache	2017
New	Approved basic 16-110709 BP	2012 IRC	Plan# 1795	2-story w/attache	2017
New	Approved basic 16-110709 BP	2012 IRC	Plan# 1795	2-story w/attache	2017
New	Approved basic 16-111204 BP	2012 IRC	Plan# 2052	2-story w/attache	2017
New	Approved basic 16-111208 BP	2012 IRC	Plan# 1536	2-story w/attache	2017
New	Approved basic 16-111208 BP	2012 IRC	Plan# 1536	2-story w/attache	2017
New	Approved basic 16-110712 BP	2012 IRC	Plan# 1608	2-story w/attache	2017
New	Approved basic 16-111208 BP	2012 IRC	Plan# 1536	2-story w/attache	2017
New	Approved basic 16-111204 BP	2012 IRC	Plan# 2052	2-story w/attache	2017
New	Approved basic 16-111204 BP	2012 IRC	Plan# 2052	2-story w/attache	2017
New	Approved basic 16-111087 BP	2012 IRC	Plan# 1708	2-story w/attache	2017
New	Approved basic 16-110704 BP	2012 IRC	Plan# 1856	2-story w/attache	2017
New	Approved Basic 16-118887 BP	2015 IRC	Plan# 1465	2-story sfr w/attach	2017
New	Approved basic 16-118887 BP	2015 IRC	Plan# 1465	2-story sfr w/attach	2017
New	Approved basic 16-110709 BP	2012 IRC	Plan# 1795	2-story w/attache	2017
New	Approved basic 16-110709 BP	2012 IRC	Plan# 1795	2-story w/attache	2017
New	Approved basic 16-110709 BP	2012 IRC	Plan# 1795	2-story w/attache	2017
New	New 2-story, 2,177 SF SFR with 400 SF attached garage, 224 SF covered deck. (849 SF of finishe				2017
New	New 2-story, 2,177 SF SFR with 400 SF attached garage and 224 SF covered deck (849 SF of finis				2017
New	New SFR				2017
New	Expiration date extended 120 days per Emergency Ordinance 20-027 New SFR				2017
New	Approved basic 17-105451 BP	2015 IRC	Plan# 2477 (38#)	2 story SI	2017
New	Approved basic 16-118177 BP	2015 IRC	Plan# 2370	2-story sfr w/	2017
New	Approved basic 16-118185 BP	2015 IRC	Plan# 2537	2-story sfr w/	2017
New	Approved basic 17-105451 BP	2015 IRC	Plan# 2477 (38#)	2 story SI	2017

Accessory Dwelling Units

Index # - File Name: 1.0022 - Single Family Dwellings Data\_Snohomish County.pdf

New	New 2-story SFR w/ attached garage			SEE: 16-108188-LDA & 1	2017
New	Approved basic 16-113274 BP	2015 IRC	Plan# Mason C	2-story sfr w/attached g	2017
New	2197 s.f. rambler with attached garage				2017
New	Approved basic 16-112153 BP	2015 IRC	Plan# Baker C	2-story sfr w/attached gara	2017
New	New 3 story (including basement) 2,003 SF SFR with 220 SF attached garage and covered deck				2017
New	New 1741 sf 3-story SFR with 241 sf garage, 84 sf covered porch and 109 sf deck				2017
New	New 1741 3-story SFR with 241 sf garage, 84 sf covered deck, 108 sf deck				2017
New	Two Story SFR with finished Basement and attached Garage				2017
New	Two story SFR with Finished Basement and attached Garage				2017
New	SFR: 2 story with attached garage, 2 bedroom/2.5 bath				2017
New	New 1,393 SF, 2-story SFR with 241 SF attached garage.				2017
New	New 3-story (including basement) 2,172 SF SFR with 424 SF attached garage and covered deck/c				2017
New	Approved basic 16-121949 BP	2015 IRC	Plan# 2578	Rambler w/atta	2017
New	Approved basic 16-118176 BP	2015 IRC	Plan# 2541	2-story sfr w	2017
New	Approved basic 16-120263 BP	2015 IRC	Plan# 2458	Rambler w/att	2017
New	Approved basic 16-121949 BP	2015 IRC	Plan# 2578	Rambler w/atta	2017
New	Approved basic 16-118183 BP	2015 IRC	Plan# 3049	2-story sfr w/	2017
New	Approved basic 16-118181 BP	2015 IRC	Plan# 3017	2-story sfr w/i	2017
New	Approved basic 16-118182 BP	2015 IRC	Plan# 2972	2-story sfr w	2017
New	Approved basic 16-121949 BP	2015 IRC	Plan# 2578	Rambler w/atta	2017
New	SFR, tri-level with attached garage, 4 bedrooms, 3.5 baths				2017
New	New 3-story 2,172 SF SFR with 424 SF attached garage, as well as covered deck and deck.				2017
New	New 3-story, 2,187 SF SFR with 453 SF attached garage, covered deck, and deck.				2017
New	New 3 story 2157 sq ft Single Family Residence including attached 453 sq ft garage.				2017
New	4 Bedroom, 3+ bath single family residence including basement and attached garage.				2017
New	SFR: 2 story with attached garage, 4 bedroom/2.5 bath				2017
New	Two story SFR with attached Garage				2017
New	SFR: Two story with finished basement, 4 bedroom 3.5 baths				2017
New	Two story SFR with finished Basement and attached Garage				2017
New	Single family residence with single car attached garage, 2 story style home with basement, 3 be				2017
New	3 story sfr with attached garage	2015 IRC			2017
New	4 bedroom, 3 story (including basement) 3+ bathroom single family residence with attached gar				2017
New	SFR - Tri-level style (3 story home) with attached garage, 4 bedrooms, 3.5 baths				2017
New	New 3 story , 2,187 SF SFR with 453 SF attached garage, covered deck and deck.				2017
New	Two story SFR with Finished Basement and attached Garage				2017
New	New 1,393 SF, 2-story SFR with 241 SF attached garage.				2017
New	Approved basic 16-118186 BP	2015 IRC	Plan# 2060	Rambler w/atta	2017
New	Two story SFR with attached Garage				2017
New	Approved basic 15-106745 BP	2012 IRC	Plan# Baker C	2-story sfr w/attached gara	2017
New	Approved basic 15-106745 BP	2012 IRC	Plan# Baker C	2-story sfr w/attached gara	2017
New	2 story sfr with attached garage	2015 IRC			2017
New	2 story sfr with attached garage	2015 IRC			2017
New	Revision to Permit 16-111038 RK to switch basics to 15-106745 BP. All inspections to be compl				2017
New	Approved basic 15-107152 BP	2012 IRC	Plan# Dayton D	2-story sfr w/attached g	2017
New	Approved basic 15-110460 BP	2012 IRC	Plan# Campbell II D	2-story sfr w/attached gar	2017
New	Approved basic 15-117472 BP	2012 IRC	Plan# Newhalem D	2-story sfr w/attach	2017
New	Approved basic 15-102332 BP	2012 IRC	Plan# Rainier C	2-story sfr w/attached gara	2017

Accessory Dwelling Units

Index # - File Name: 1.0022 - Single Family Dwellings Data\_Snohomish County.pdf

New	Approved basic 16-103808 BP	2012 IRC	Plan# Kimball D	2-story sfr w/attached g	2017
New	Approved basic 15-107152 BP	2012 IRC	Plan# Dayton D	2-story sfr w/attached g	2017
New	Approved basic 15-117474 BP	2012 IRC	Plan# Trafton D	2-story sfr w/attached g	2017
New	Approved basic 15-102333 BP	2012 IRC	Plan# Rainer D	2-story sfr w/attached g	2017
New	Approved basic 15-110113 BP	2012 IRC	Plan# Hazelwood-C	2-story sfr w/attached gar	2017
New	Approved basic 15-110114 BP	2012 IRC	Plan# Hazelwood-D	2-story sfr w/attached gar	2017
New	Approved basic 16-100166 BP	2012 IRC	Plan# Cavanaugh C/D	2-story sfr w/at	2017
New	Approved basic 15-117473 BP	2012 IRC	Plan# Trafton C	2-story sfr w/attached	2017
New	Approved basic 16-100166 BP	2012 IRC	Plan# Cavanaugh C/D	2-story sfr w/at	2017
New	Approved basic 15-102333 BP	2012 IRC	Plan# Rainer D	2-story sfr w/attached g	2017
New	Approved basic 15-117473 BP	2012 IRC	Plan# Trafton C	2-story sfr w/attached	2017
New	Approved basic 16-103807 BP	2012 IRC	Plan# Kimball C	2-story sfr w/attached g	2017
New	Approved basic 15-117471 BP	2012 IRC	Plan# Newhalem C	2-story sfr w/attached	2017
New	Approved basic 15-110113 BP	2012 IRC	Plan# Hazelwood-C	2-story sfr w/attached gar	2017
New	Approved basic 16-100166 BP	2012 IRC	Plan# Cavanaugh C/D	2-story sfr w/at	2017
New	Approved basic 15-102332 BP	2012 IRC	Plan# Rainier C	2-story sfr w/attached gara	2017
New	Approved basic 15-110460 BP	2012 IRC	Plan# Campbell II D	2-story sfr w/attached gar	2017
New	Approved basic 15-111285 BP	2012 IRC	Plan# Granite D	2-story sfr w/attached gara	2017
New	Approved basic 15-110114 BP	2012 IRC	Plan# Hazelwood-D	2-story sfr w/attached gar	2017
New	Approved basic 16-103808 BP	2012 IRC	Plan# Kimball D	2-story sfr w/attached g	2017
New	Approved basic 15-117474 BP	2012 IRC	Plan# Trafton D	2-story sfr w/attached g	2017
New	Expiration date extended 120 days per Emergency Ordinance 20-027			2 story sfr with attached g	2017
New	Two story SFR with attached Garage				2017
New	Two story SFR with attached Garage				2017
New	2 story w/153 s.f. finished basement and attached garage				2017
New	2 story w/153 s.f. finished basement and attached garage				2017
New	New 2-story 4,160 SF SFR with 900 SF attached garage.				2017
New	Approved basic 17-105451 BP	2015 IRC	Plan# 2477 (38#)	2 story SI	2017
New	Approved basic 16-118179 BP	2015 IRC	Plan# 2370 (38#)	2-story	2017
New	Approved basic 17-105451 BP	2015 IRC	Plan# 2477 (38#)	2 story SI	2017
New	Approved basic 17-105451 BP	2015 IRC	Plan# 2477 (38#)	2 story SI	2017
New	Approved basic 16-118187 BP	2015 IRC	Plan# 2060 (38#)	Ramble	2017
New	Approved Basic 17-105863 BP	2015 IRC	1704-38#	1704sf daylight rambler \	2017
New	Approved basic 17-105451 BP	2015 IRC	Plan# 2477 (38#)	2 story SI	2017
New	Approved basic 17-106558 BP	2015 IRC	Plan# 2537 38#	2-story sfr w/a	2017
New	Approved basic 16-118175 BP	2015 IRC	Plan# 2541 (38#)	2-story	2017
New	Approved basic 17-106558 BP	2015 IRC	Plan# 2537 38#	2-story sfr w/att	2017
New	Approved basic 17-105451 BP	2015 IRC	Plan# 2477 (38#)	2 story SI	2017
New	New 2,178 sf 2-story SFR with 495 sf garage and 42 sf covered porch			Airport Influence AFN 20	2017
New	Two story SFR with attached Garage				2017
New	Two story SFR with attached Garage				2017
New	Two story SFR with attached Garage				2017
New	2 Story SFR with attached garage				2017
New	New 2800 sf 2-story SFR with 488 sf garage and 123 sf covered porch				2017
New	New 1-story 1,807 SF SFR with 495 SF attached garage and 247 SF covered deck.				2017
New	2 story sfr w/finished basement and attached garage				2017
New	2 story sfr w/finished basement & attached garage				2017



Accessory Dwelling Units

Index # - File Name: 1.0022 - Single Family Dwellings Data\_Snohomish County.pdf

New	Approved Basic 17 109866BP	2015 IRC	plan 2001.	2001 Sq. Ft	2 story home with attached garage	2017
New	Approved Basic 17 109866BP	2015 IRC	plan 2001.	2001 Sq. Ft	2 story home with attached garage	2017
New	Approved Basic 17 109866BP	2015 IRC	plan 2001.	2001 Sq. Ft	2 story home with attached garage	2017
New	Approved Basic 17-109888BP	2015 IRC	Plan: 2646 A/B	2646sq. ft.	Tri Level SFR with attached garage	2017
New	Approved Basic 17-109888BP	2015 IRC	Plan: 2646 A/B	2646sq. ft.	Tri Level SFR with attached garage	2017
New	Approved Basic 17-109888BP	2015 IRC	Plan: 2646 A/B	2646sq. ft.	Tri Level SFR with attached garage	2017
New	Approved Basic 17 112543BP	2015 IRC	Plan 1921	2 story home with attached garage		2017
New	Approved Basic 17-109888BP	2015 IRC	Plan: 2646 A/B	2646sq. ft.	Tri Level SFR with attached garage	2017
New	Approved Basic 17-109888BP	2015 IRC	Plan: 2646 A/B	2646sq. ft.	Tri Level SFR with attached garage	2017
New	Approved Basic 17 112543BP	2015 IRC	Plan 1921	2 story home with attached garage		2017
New	Approved Basic 17-109888BP	2015 IRC	Plan: 2646 A/B	2646sq. ft.	Tri Level SFR with attached garage	2017
New	Approved Basic 17-109888BP	2015 IRC	Plan: 2646 A/B	2646sq. ft.	Tri Level SFR with attached garage	2017
New	Approved Basic 17 112543BP	2015 IRC	Plan 1921	2 story home with attached garage		2017
New	Approved Basic 17-109888BP	2015 IRC	Plan: 2646 A/B	2646sq. ft.	Tri Level SFR with attached garage	2017
New	Approved Basic 17-109888BP	2015 IRC	Plan: 2646 A/B	2646sq. ft.	Tri Level SFR with attached garage	2017
New	Approved Basic 17 112543BP	2015 IRC	Plan 1921	2 story home with attached garage		2017
New	Approved Basic 17 109866BP	2015 IRC	plan 2001.	2001 Sq. Ft	2 story home with attached garage	2017
New	Approved Basic 17 109866BP	2015 IRC	plan 2001.	2001 Sq. Ft	2 story home with attached garage	2017
New	Approved basic 16-117920 BP	2015 IRC	Plan# Lexington C/D	3-story sfr w/attached garage		2017
New	2017 14 X 56 Single-Wide Fleetwood Eagle Mobile Home					2017
New	New 3,023 2-story SFR with 730 sf garage, 205 sf covered porch, and 300 sf deck					2017
New	New 2,458 2-story SFR with 1230 sf covered porch					2017
New	Approved basic 17-100203 BP	2015 IRC	Plan# 2254 (25#)	Rambler w/attached garage		2017
New	Approved basic 16-118176 BP	2015 IRC	Plan# 2541	2-story sfr w/attached garage		2017
New	Approved basic 16-118177 BP	2015 IRC	Plan# 2370	2-story sfr w/attached garage		2017
New	Approved basic 17-100203 BP	2015 IRC	Plan# 2254 (25#)	Rambler w/attached garage		2017
New	Approved basic 16-118177 BP	2015 IRC	Plan# 2370	2-story sfr w/attached garage		2017
New	Approved basic 16-118176 BP	2015 IRC	Plan# 2541	2-story sfr w/attached garage		2017
New	Approved basic 16-118186 BP	2015 IRC	Plan# 2060	Rambler w/attached garage		2017
New	Approved basic 16-108597 BP	2015 IRC	Plan# Dayton C	2-story sfr w/attached garage		2017
New	Approved basic 16-113865 BP	2015 IRC	Plan # Newhalem C	2-story sfr w/attached garage		2017
New	Approved Basic 16-113032 BP	2015 IRC	Plan# Rainier C	2-story sfr w/attached garage		2017
New	Approved basic 16-108632 BP	2015 IRC	Plan# Cavanaugh C/D	2-story sfr w/attached garage		2017
New	Approved basic 16-113033 BP	2015 IRC	Plan# Rainier D	2-story sfr w/attached garage		2017
New	Approved basic 16-121325 BP	2015 IRC	Plan# Newhalem D Daylight	2-story sfr w/attached garage		2017
New	Approved basic 16-108598 BP	2015 IRC	Plan# Dayton D	2-story sfr w/attached garage		2017
New	Approved basic 16-113865 BP	2015 IRC	Plan # Newhalem C	2-story sfr w/attached garage		2017
New	Approved basic 16-113330 BP	2015 IRC	Plan# Trafton D	2-story sfr w/attached garage		2017
New	Approved basic 17-100203 BP	2015 IRC	Plan# 2254 (25#)	Rambler w/attached garage		2017
New	2 story sfr with attached garage		2015 IRC			2017
New	2 story sfr with attached garage		2015 IRC			2017
New	Two story SFR with attached Garage					2017
New	New 2-story (with a basement) 3,052 SF SFR with 393 SF attached garage, covered deck and driveway					2017
New	Approved Basic 17-108112 BP	2015 IRC	Plan # 3471 A	3471sf three story SFR		2017
New	Approved 17-108022 BP	2015 IRC	Plan# 3316 B	3316 3 story residence		2017
New	Approved Basic 17-108112 BP	2015 IRC	Plan # 3471 A	3471sf three story SFR		2017
New	Approved Basic 17-108015BP	2015 IRC	Plan#3316 A	3316sf 3 story residence		2017



Accessory Dwelling Units

Index # - File Name: 1.0022 - Single Family Dwellings Data\_Snohomish County.pdf

New	Approved Basic 17-108111BP	2015 IRC	Plan #3471	3471sf three st	2017
New	Approved 17-108022 BP	2015 IRC	Plan# 3316 B	3316 3 story reside	2017
New	Approved Basic 17-108112 BP	2015 IRC	Plan # 3471 A	3471sf three story SF	2017
New	Approved Basic 17-108109	2015 IRC	PLAN#: 3395B	3395SF two story SFR w	2017
New	Approved basic 17-100313 BP	2015 IRC	Plan# 2501B	2-story sfr w/attache	2017
New	Approved basic 16-111597 BP	2015 IRC	Plan# 2494A	2-story w/attache	2017
New	Approved basic 17-100312 BP	2015 IRC	Plan# 2501A	2-story sfr w/attache	2017
New	Approved Basic 17-110300 BP	2015 IRC	Plan 2210 CD 2015	3 story SFR with Attac	2017
New	Approved basic 16-118443 BP	2015 IRC	Plan# 2301 AB 2015	2-story sf	2017
New	Approved basic 16-119082BP	2015 IRC	Plan# 2518 AB 2015	3-story sfr	2017
New	Approved basic 16-118715 BP	2015 IRC	Plan# 2008 AB 2015	2-story s	2017
New	Approved basic 16-119082BP	2015 IRC	Plan# 2518 AB 2015	3-story sfr	2017
New	Approved basic 16-118715 BP	2015 IRC	Plan# 2008 AB 2015	2-story s	2017
New	Approved basic 16-118443 BP	2015 IRC	Plan# 2301 AB 2015	2-story sf	2017
New	Approved basic 16-119082BP	2015 IRC	Plan# 2518 AB 2015	3-story sfr	2017
New	Approved basic 16-118443 BP	2015 IRC	Plan# 2301 AB 2015	2-story sf	2017
New	Approved basic 16-118715 BP	2015 IRC	Plan# 2008 AB 2015	2-story s	2017
New	Approved basic 16-119082BP	2015 IRC	Plan# 2518 AB 2015	3-story sfr	2017
New	Approved basic 16-118443 BP	2015 IRC	Plan# 2301 AB 2015	2-story sf	2017
New	Approved basic 16-119082BP	2015 IRC	Plan# 2518 AB 2015	3-story sfr	2017
New	Approved basic 16-118443 BP	2015 IRC	Plan# 2301 AB 2015	2-story sf	2017
New	Approved basic 16-118715 BP	2015 IRC	Plan# 2008 AB 2015	2-story s	2017
New	Approved basic 16-119082BP	2015 IRC	Plan# 2518 AB 2015	3-story sfr	2017
New	Approved basic 16-118443 BP	2015 IRC	Plan# 2301 AB 2015	2-story sf	2017
New	Approved Basic 16-115219 BP	2015 IRC	Plan# 2165	2-story SFR w/ attached gar	2017
New	Approved Basic 17-106824 BP	2015 IRC	Plan 2103 The Benson	two story SFR with at	2017
New	Approved Basic 17-106874 BP	2015 IR	Plan # 2138	2138sf 2 story single family re:	2017
New	Approved Basic 17-106824 BP	2015 IRC	Plan 2103 The Benson	two story SFR with at	2017
New	Approved Basic 17-106874 BP	2015 IRC	Plan # 2138	2138sf 2 story	2017
New	Approved Basic 17-106824 BP	2015 IRC	Plan 2103 The Benson	two story SFR with at	2017
New	Approved Basic 17-106874 BP	2015 IRC	Plan # 2138	2138sf 2 story	2017
New	Approved basic 16-115735 BP	2015 IRC	Plan# 440 A	2-story sfr w/attac	2017
New	Approved basic 16-119084 BP	2015 IRC	Plan# 442 B	2-story sfr w/attac	2017
New	Approved basic 16-115735 BP	2015 IRC	Plan# 440 A	2-story sfr w/attac	2017
New	Approved basic 16-119083 BP	2015 IRC	Plan# 440 B	2-story sfr w/atta	2017
New	Approved basic 16-115739 BP	2015 IRC	Plan# 443 A	2-story sfr w/attache	2017
New	Approved basic 16-119084 BP	2015 IRC	Plan# 442 B	2-story sfr w/attac	2017
New	Approved basic 16-119086 BP	2015 IRC	Plan# 443 B	2-story sfr w/attac	2017
New	Approved basic 16-115739 BP	2015 IRC	Plan# 443 A	2-story sfr w/attache	2017
New	Approved basic 16-119086 BP	2015 IRC	Plan# 443 B	2-story sfr w/attac	2017
New	Approved basic 16-115739 BP	2015 IRC	Plan# 443 A	2-story sfr w/attache	2017
New	Approved basic 16-119083 BP	2015 IRC	Plan# 440 B	2-story sfr w/atta	2017
New	Approved basic 16-115930 BP	2015 IRC	Plan# 545 A	2-story sfr w/attache	2017
New	Approved basic 16-119088 BP	2015 IRC	Plan# 545 B	2-story sfr w/finishe	2017
New	Approved basic 16-115930 BP	2015 IRC	Plan# 545 A	2-story sfr w/attache	2017
New	Approved basic 16-119088 BP	2015 IRC	Plan# 545 B	2-story sfr w/finishe	2017

Accessory Dwelling Units

Index # - File Name: 1.0022 - Single Family Dwellings Data\_Snohomish County.pdf

New	Approved basic 16-115928 BP	2015 IRC	Plan# 444 A	2-story sfr w/attach	2017
New	Approved basic 16-115737 BP	2015 IRC	Plan# 442 A	2-story sfr w/attach	2017
New	Approved basic 16-119084 BP	2015 IRC	Plan# 442 B	2-story sfr w/attach	2017
New	Approved basic 16-115928 BP	2015 IRC	Plan# 444 A	2-story sfr w/attach	2017
New	Approved basic 16-115737 BP	2015 IRC	Plan# 442 A	2-story sfr w/attach	2017
New	Approved basic 16-119084 BP	2015 IRC	Plan# 442 B	2-story sfr w/attach	2017
New	Approved basic 16-119086 BP	2015 IRC	Plan# 443 B	2-story sfr w/attach	2017
New	Approved basic 16-119083 BP	2015 IRC	Plan# 440 B	2-story sfr w/attach	2017
New	Approved basic 16-115928 BP	2015 IRC	Plan# 444 A	2-story sfr w/attach	2017
New	Approved basic 16-116963BP	2015 IRC	Plan# 1511	2-story duplex w/attach	2017
New	2 story sfr with attached garage	2015 IRC	Airport Influence #201704110551		2017
New	2 story sfr with attached garage	2015 IRC	Airport Influence #201704110549		2017
New	2 story sfr with attached garage	2015 IRC	Airport Influence #201704110550		2017
New	New 2433 sq ft 2 story sfr				2017
New	New 2,260 sf 2-story SFR with 700 sf garage and 500 sf covered deck				2017
New	New 2,441 sf 2-story SFR with 792 sf garage and 338 sf covered porch				2017
New	Approved basic 16-114982 BP	2015 IRC	Plan# 3072	2-story sfr w/attached	2017
New	Approved basic 16-118797 BP	2015 IRC	Plan# 2813	2-story sfr w/attached	2017
New	Approved basic 16-114982 BP	2015 IRC	Plan# 3072	2-story sfr w/attached ga	2017
New	Approved basic 16-114982 BP	2015 IRC	Plan# 3072	2-story sfr w/attached ga	2017
New	Approved basic 16-118797 BP	2015 IRC	Plan# 2813	2-story sfr w/attached	2017
New	2 story w/attached garage				2017
New	2 story sfr w/attached garage Sent RSP to SHD 12/8/17 and to Jack Hurley to review infiltration				2017
New	2 story sfr w/attached garage Sent RSP to SHD 12/8/17 and to Jack Hurley to review infiltration				2017
New	Approved basic 16-118443 BP	2015 IRC	Plan# 2301 AB 2015	2-story sf	2017
New	Approved basic 16-118715 BP	2015 IRC	Plan# 2008 AB 2015	2-story s	2017
New	Approved basic 16-118443 BP	2015 IRC	Plan# 2301 AB 2015	2-story sf	2017
New	Approved basic 16-119082 BP	2015 IRC	Plan# 2518 AB 2015	3-story sfr	2017
New	Approved basic 16-118443 BP	2015 IRC	Plan# 2301 AB 2015	2-story sf	2017
New	Approved basic 16-118715 BP	2015 IRC	Plan# 2008 AB 2015	2-story s	2017
New	Approved basic 16-118443 BP	2015 IRC	Plan# 2301 AB 2015	2-story sf	2017
New	Approved basic 16-119082BP	2015 IRC	Plan# 2518 AB 2015	3-story sfr	2017
New	Approved basic 16-118715 BP	2015 IRC	Plan# 2008 AB 2015	2-story s	2017
New	Approved basic 16-118715 BP	2015 IRC	Plan# 2008 AB 2015	2-story s	2017
New	Approved basic 16-118443 BP	2015 IRC	Plan# 2301 AB 2015	2-story sf	2017
New	Approved basic 16-122036 BP	2015 IRC	Plan# 2418 AB 2015	3-story sfr v	2017
New	Approved basic 16-122036 BP	2015 IRC	Plan# 2418 AB 2015	3-story sfr v	2017
New	Approved basic 16-119082BP	2015 IRC	Plan# 2518 AB 2015	3-story sfr	2017
New	Approved basic 16-118443 BP	2015 IRC	Plan# 2301 AB 2015	2-story sf	2017
New	Approved basic 16-118715 BP	2015 IRC	Plan# 2008 AB 2015	2-story s	2017
New	Approved basic 16-119082BP	2015 IRC	Plan# 2518 AB 2015	3-story sfr	2017
New	Approved basic 16-118443 BP	2015 IRC	Plan# 2301 AB 2015	2-story sf	2017
New	Approved basic 16-118443 BP	2015 IRC	Plan# 2301 AB 2015	2-story sf	2017
New	Approved basic 16-118443 BP	2015 IRC	Plan# 2301 AB 2015	2-story sf	2017
New	Approved basic 16-118443 BP	2015 IRC	Plan# 2301 AB 2015	2-story sf	2017
New	Approved basic 16-119082BP	2015 IRC	Plan# 2518 AB 2015	3-story sfr	2017
New	Approved basic 16-119082BP	2015 IRC	Plan# 2518 AB 2015	3-story sfr	2017

Accessory Dwelling Units

Index # - File Name: 1.0022 - Single Family Dwellings Data\_Snohomish County.pdf

New	Approved basic 16-118443 BP	2015 IRC	Plan# 2301 AB 2015	2-story sf	2017
New	Approved basic 16-118443 BP	2015 IRC	Plan# 2301 AB 2015	2-story sf	2017
New	Approved basic 16-118443 BP	2015 IRC	Plan# 2301 AB 2015	2-story sf	2017
New	Approved basic 16-118443 BP	2015 IRC	Plan# 2301 AB 2015	2-story sf	2017
New	Approved basic 16-119082BP	2015 IRC	Plan# 2518 AB 2015	3-story sfr	2017
New	Approved basic 16-118715 BP	2015 IRC	Plan# 2008 AB 2015	2-story s	2017
New	Approved basic 16-118443 BP	2015 IRC	Plan# 2301 AB 2015	2-story sf	2017
New	Approved basic 16-118715 BP	2015 IRC	Plan# 2008 AB 2015	2-story s	2017
New	Approved basic 16-119082BP	2015 IRC	Plan# 2518 AB 2015	3-story sfr	2017
New	Approved basic 16-118715 BP	2015 IRC	Plan# 2008 AB 2015	2-story s	2017
New	Approved basic 16-118715 BP	2015 IRC	Plan# 2008 AB 2015	2-story s	2017
New	Approved basic 16-118443 BP	2015 IRC	Plan# 2301 AB 2015	2-story sf	2017
New	Approved basic 16-119082 BP	2015 IRC	Plan# 2518 AB 2015	3-story sfr	2017
New	Approved basic 16-118715 BP	2015 IRC	Plan# 2008 AB 2015	2-story s	2017
New	Approved basic 16-119082BP	2015 IRC	Plan# 2518 AB 2015	3-story sfr	2017
New	Approved basic 16-118715 BP	2015 IRC	Plan# 2008 AB 2015	2-story s	2017
New	Approved basic 16-122036 BP	2015 IRC	Plan# 2418 AB 2015	3-story sfr v	2017
New	Approved basic 16-122036 BP	2015 IRC	Plan# 2418 AB 2015	3-story sfr v	2017
New	Approved basic 16-119082BP	2015 IRC	Plan# 2518 AB 2015	3-story sfr	2017
New	Approved basic 16-118715 BP	2015 IRC	Plan# 2008 AB 2015	2-story s	2017
New	Approved basic 16-118443 BP	2015 IRC	Plan# 2301 AB 2015	2-story sf	2017
New	Approved basic 16-118715 BP	2015 IRC	Plan# 2008 AB 2015	2-story s	2017
New	Approved basic 16-119082BP	2015 IRC	Plan# 2518 AB 2015	3-story sfr	2017
New	Approved basic 16-118443 BP	2015 IRC	Plan# 2301 AB 2015	2-story sf	2017
New	Approved basic 16-119082BP	2015 IRC	Plan# 2518 AB 2015	3-story sfr	2017
New	Approved basic 16-118715 BP	2015 IRC	Plan# 2008 AB 2015	2-story s	2017
New	Approved basic 16-118182 BP	2015 IRC	Plan# 2972	2-story sfr w	2017
New	Approved basic 16-118181 BP	2015 IRC	Plan# 3017	2-story sfr w/i	2017
New	Approved basic 16-120263 BP	2015 IRC	Plan# 2458	Rambler w/atta	2017
New	Approved Basic 17-109022 BP	2015 IRC	Plan# 3019 25#	3019sf two story !	2017
New	Approved basic 16-121949 BP	2015 IRC	Plan# 2578	Rambler w/atta	2017
New	Approved Basic 17-109022 BP	2015 IRC	Plan# 3019 25#	3019sf two story !	2017
New	Approved Basic 17-109022 BP	2015 IRC	Plan# 3019 25#	3019sf two story S	2017
New	Approved basic 16-120263 BP	2015 IRC	Plan# 2458	Rambler w/atta	2017
New	Approved Basic 17-109022 BP	2015 IRC	Plan# 3019 25#	3019sf two story !	2017
New	Approved basic 16-121949 BP	2015 IRC	Plan# 2578	Rambler w/atta	2017
New	Approved basic 16-118182 BP	2015 IRC	Plan# 2972	2-story sfr w	2017
New	Approved basic 16-121552 BP	2015 IRC	Plan# 2032	2-story sfr w/attac	2017
New	Approved basic 16-121553 BP	2015 IRC	Plan# 2051	2-story sfr w/attach	2017
New	Approved basic 16-121552 BP	2015 IRC	Plan# 2032	2-story sfr w/attac	2017
New	Approved basic 16-121553 BP	2015 IRC	Plan# 2051	2-story sfr w/attach	2017
New	Approved basic 16-121552 BP	2015 IRC	Plan# 2032	2-story sfr w/attac	2017
New	Approved basic 16-121553 BP	2015 IRC	Plan# 2051	2-story sfr w/attach	2017
New	Approved basic 16-121552 BP	2015 IRC	Plan# 2032	2-story sfr w/attac	2017
New	Approved basic 16-121553 BP	2015 IRC	Plan# 2051	2-story sfr w/attach	2017
New	Approved basic 16-121552 BP	2015 IRC	Plan# 2032	2-story sfr w/attac	2017
New	Approved basic 16-121553 BP	2015 IRC	Plan# 2051	2-story sfr w/attach	2017

Accessory Dwelling Units

Index # - File Name: 1.0022 - Single Family Dwellings Data\_Snohomish County.pdf

New	Approved basic 16-121552 BP	2015 IRC	Plan# 2032	2-story sfr w/attac	2017
New	Approved basic 16-121553 BP	2015 IRC	Plan# 2051	2-story sfr w/attach	2017
New	Approved basic 16-121552 BP	2015 IRC	Plan# 2032	2-story sfr w/attac	2017
New	Approved basic 16-121553 BP	2015 IRC	Plan# 2051	2-story sfr w/attach	2017
New	Approved basic 16-116963BP	2015 IRC	Plan# 1511	2-story duplex w/attac	2017
New	2 story sfr w/attached garage				2017
New	2 story sfr w/attached garage	Airport Influence Area Disclosure Notice AFN: 201701040875			2017
New	2 story sfr w/attached garage				2017
New	2 story sfr w/attached garage				2017
New	Approved Basic 16-113032 BP	2015 IRC	Plan# Rainier C	2-story sfr w/attached g	2017
New	Approved basic 16-108598 BP	2015 IRC	Plan# Dayton D	2-story sfr w/attached gar	2017
New	Approved basic 16-108632 BP	2015 IRC	Plan# Cavanaugh C/D	2-story sfr w/att	2017
New	Approved basic 16-113867 BP	2015 IRC	Plan# Newhalem D	2-story sfr w/attache	2017
New	Approved basic 16-113033 BP	2015 IRC	Plan# Rainier D	2-story sfr w/attached g	2017
New	Approved basic 16-113328 BP	2015 IRC	Plan# Trafton C	2-story sfr w/attached	2017
New	Approved basic 16-112022 BP	2015 IRC	Plan# Trafton D Daylight	2-stor	2017
New	Two story SFR with attached Garage				2017
New	New 2784 sq. ft. sfr with attached garage	2015 IRC			2017
New	SFR: new rambler style home with attached garage				2017
New	SFR: new rambler style home with attached 3 car garage (4 bedrooms/3 baths)				2017
New	SFR, 2 story with 3 car attached garage and covered back porch				2017
New	New 2-story, 3,098 SF SFR with 1,106 SF attached garage and 438 SF covered decks.				2017
New	New single story residence with attached garage				2017
New	Approved basic 16-118163 BP	2015 IRC	Plan# 2824	2-story sfr w/finished bas	2017
New	Approved basic 16-118164 BP	2015 IRC	Plan# 3015 A	2-story sfr w/finished bi	2017
New	Approved basic 16-118155 BP	2015 IRC	Plan# 3079 A	2-story sfr w/finished l	2017
New	Approved basic 16-118861 BP	2015 IRC	Plan# 3015 B	2-story sfr w/finished l	2017
New	Approved basic 16-118857 BP	2015 IRC	Plan# 3079 B	2-story sfr w/finished b	2017
New	Approved basic 16-118164 BP	2015 IRC	Plan# 3015 A	2-story sfr w/finished bi	2017
New	Approved basic 16-118155 BP	2015 IRC	Plan# 3079 A	2-story sfr w/finished l	2017
New	Approved basic 16-118861 BP	2015 IRC	Plan# 3015 B	2-story sfr w/finished l	2017
New	Approved basic 16-118857 BP	2015 IRC	Plan# 3079 B	2-story sfr w/finished b	2017
New	Approved basic 16-118163 BP	2015 IRC	Plan# 2824	2-story sfr w/finished bas	2017
New	Approved basic 16-118164 BP	2015 IRC	Plan# 3015 A	2-story sfr w/finished bi	2017
New	Approved basic 16-118859 BP	2015 IRC	Plan# 2202 B	2-story sfr w,	2017
New	Approved basic 16-118858 BP	2015 IRC	Plan# 2162 B	2-story sfr w/	2017
New	Approved basic 16-118159 BP	2015 IRC	Plan# 2074B	2-story sfr \	2017
New	Approved basic 16-118159 BP	2015 IRC	Plan# 2074B	2-story sfr \	2017
New	Approved basic 16-118162 BP	2015 IRC	Plan# 2202 A	2-story sfr w/	2017
New	Approved basic 16-118160 BP	2015 IRC	Plan# 2162 A	2-story sfr w,	2017
New	Approved basic 16-118159 BP	2015 IRC	Plan# 2074B	2-story sfr \	2017
New	Approved basic 16-118162 BP	2015 IRC	Plan# 2202 A	2-story sfr w/	2017
New	Approved basic 16-118160 BP	2015 IRC	Plan# 2162 A	2-story sfr w,	2017
New	Approved basic 16-118157 BP	2015 IRC	Plan# 2000A	2-story sfr \	2017
New	Approved basic 16-118859 BP	2015 IRC	Plan# 2202 B	2-story sfr w,	2017
New	Approved basic 16-118858 BP	2015 IRC	Plan# 2162 B	2-story sfr w/	2017
New	Approved basic 16-118157 BP	2015 IRC	Plan# 2000A	2-story sfr \	2017

Accessory Dwelling Units

Index # - File Name: 1.0022 - Single Family Dwellings Data\_Snohomish County.pdf

New	Approved basic 16-118858 BP	2015 IRC	Plan# 2162 B	2-story sfr w/	2017
New	Approved basic 16-118160 BP	2015 IRC	Plan# 2162 A	2-story sfr w,	2017
New	Approved basic 16-121634 BP	2015 IRC	Plan# 2370	2-story sfr w/attache	2017
New	Approved basic 16-121633BP	2015 IRC	Plan# 2458	2-story sfr w/attache	2017
New	Approved basic 16-121634 BP	2015 IRC	Plan# 2370	2-story sfr w/attache	2017
New	2230 s.f. rambler w/attached garage				2017
New	New 2-story 2,214 SF SFR with 790 SF covered deck.				2017
New	New 1-story 1,920 SF SFR with 400 SF attached garage and covered porch.				2017
New	Approved basic 16-117674 BP	2015 IRC	Plan# Palmer C/D	3-story sfr w/tan	2017
New	Approved basic 16-115979 BP	2015 IRC	Plan# Amherst C/D	2-story sfr w/ç	2017
New	Approved basic 16-118225 BP	2015 IRC	Plan# Huntington C/D	3-story sfr w/	2017
New	Approved basic 16-117137 BP	2015 IRC	Plan# Kingston C/D	3-story sfr w/t	2017
New	Approved basic 16-115979 BP	2015 IRC	Plan# Amherst C/D	2-story sfr w/ç	2017
New	Approved basic 16-117674 BP	2015 IRC	Plan# Palmer C/D	3-story sfr w/tan	2017
New	Approved basic 16-117920 BP	2015 IRC	Plan# Lexington C/D	3-story sfr w/t:	2017
New	Approved basic 16-118225 BP	2015 IRC	Plan# Huntington C/D	3-story sfr w/	2017
New	Approved Basic 17-111130 BP	2015 IRC	PLAN: Palmer II C/D	2451sf three st	2017
New	Approved basic 16-117137 BP	2015 IRC	Plan# Kingston C/D	3-story sfr w/t	2017
New	Approved basic 16-118225 BP	2015 IRC	Plan# Huntington C/D	3-story sfr w/	2017
New	Approved basic 16-117137 BP	2015 IRC	Plan# Kingston C/D	3-story sfr w/t	2017
New	Approved basic 16-115979 BP	2015 IRC	Plan# Amherst C/D	2-story sfr w/partial finished	2017
New	Approved Basic 17-111130 BP	2015 IRC	PLAN: Palmer II C/D	2451sf three stor	2017
New	Approved Basic 17-111130 BP	2015 IRC	PLAN: Palmer II C/D	2451sf three stc	2017
New	Approved basic 16-115979 BP	2015 IRC	Plan# Amherst C/D	2-story sfr w/ç	2017
New	Approved Basic 17-111130 BP	2015 IRC	PLAN: Palmer II C/D	2451sf three	2017
New	Approved basic 16-115979 BP	2015 IRC	Plan# Amherst C/D	2-story sfr w/ç	2017
New	Approved Basic 17-111130 BP	2015 IRC	PLAN: Palmer II C/D	2451sf three	2017
New	Approved basic 16-115979 BP	2015 IRC	Plan# Amherst C/D	2-story sfr w/ç	2017
New	Approved Basic 17-111130 BP	2015 IRC	PLAN: Palmer II C/D	2451sf three	2017
New	Approved basic 16-117674 BP	2015 IRC	Plan# Palmer C/D	3-story sfr w/tan	2017
New	Approved basic 16-117137 BP	2015 IRC	Plan# Kingston C/D	3 story sfr w/tan	2017
New	Approved basic 16-117920 BP	2015 IRC	Plan# Lexington C/D	3-story sfr w/t:	2017
New	Approved basic 16-118225 BP	2015 IRC	Plan# Huntington C/D	3-story sfr w/	2017
New	Approved basic 16-117137 BP	2015 IRC	Plan# Kingston C/D	3-story sfr w/t	2017
New	Approved basic 16-117920 BP	2015 IRC	Plan# Lexington C/D	3-story sfr w/t:	2017
New	Approved basic 16-118225 BP	2015 IRC	Plan# Huntington C/D	3-story sfr w/	2017
New	Approved basic 16-117137 BP	2015 IRC	Plan# Kingston C/D	3-story sfr w/t	2017
New	Approved basic 16-117920 BP	2015 IRC	Plan# Lexington C/D	3-story sfr w/t:	2017
New	Approved basic 16-115979 BP	2015 IRC	Plan# Amherst C/D	2-story sfr w/partial finish	2017
New	Approved basic 16-115979 BP	2015 IRC	Plan# Amherst C/D	2-story sfr w/partial finishe	2017
New	Approved basic 16-117137 BP	2015 IRC	Plan# Kingston C/D	3-story sfr w/t	2017
New	Approved basic 16-118225 BP	2015 IRC	Plan# Huntington C/D	3-story sfr w/	2017
New	Approved basic 16-117920 BP	2015 IRC	Plan# Lexington C/D	3-story sfr w/t:	2017
New	Approved basic 16-118225 BP	2015 IRC	Plan# Huntington C/D	3-story sfr w/	2017
New	Approved basic 16-117137 BP	2015 IRC	Plan# Kingston C/D	3-story sfr w/t	2017
New	Approved basic 16-117920 BP	2015 IRC	Plan# Lexington C/D	3-story sfr w/t:	2017
New	Approved basic 16-118225 BP	2015 IRC	Plan# Huntington C/D	3-story sfr w/	2017

Accessory Dwelling Units

Index # - File Name: 1.0022 - Single Family Dwellings Data\_Snohomish County.pdf

New	Approved basic 16-117920 BP	2015 IRC	Plan# Lexington C/D	3-story sfr w/t	2017
New	Approved basic 16-117137 BP	2015 IRC	Plan# Kingston C/D	3-story sfr w/t	2017
New	Approved basic 16-117674 BP	2015 IRC	Plan# Palmer C/D	3-story sfr w/tan	2017
New	New 2,106 sf rambler with 737 sf garage and 188 sf covered porch note: permit transfer from A				2017
New	Approved basic 17-100203 BP	2015 IRC	Plan# 2254 (25#)	Rambler v	2017
New	Approved basic 16-119392 BP	2015 IRC	Plan# Blake	2-story sfr w/attac	2017
New	Approved basic 16-120404 BP	2015 IRC	Plan# Chelan	2-story sfr w/atta	2017
New	Approved basic 17-103126 BP	2015 IRC	Plan# Paradise 4	2-story sfr w/	2017
New	Approved basic 16-116042 BP	2015 IRC	Plan# 447 A	2-story sfr w/attach	2017
New	Approved basic 16-116041 BP	2015 IRC	Plan# 456 A	2-story sfr w/attache	2017
New	Approved basic 16-113281	2015 IRC	Plan# 417 F	2-story w/attached gara	2017
New	Approved basic 16-113482 BP	2015 IRC	Plan# 424 E	2-story w/attached gara	2017
New	Approved basic 16-121092 BP	2015 IRC	Plan# Okanogan	2-story sfr w/a	2017
New	Approved basic 16-120404 BP	2015 IRC	Plan# Chelan	2-story sfr w/atta	2017
New	Approved basic 16-121092 BP	2015 IRC	Plan# Okanogan	2-story sfr w/a	2017
New	Approved basic 16-113444	2015 IRC	Plan# 474 A	2-story w/attached gara	2017
New	Approved basic 16-113588 BP	2015 IRC	Plan# 473 A	2-story w/attached gara	2017
New	Approved basic 16-120573 BP	2015 IRC	Plan# 447 B	2-story sfr w/ attach	2017
New	Approved basic 16-113446 BP	2015 IRC	Plan# 474 B	2-story w/attached gara	2017
New	Approved basic 16-120404 BP	2015 IRC	Plan# Chelan	2-story sfr w/atta	2017
New	Approved basic 17-103126 BP	2015 IRC	Plan# Paradise 4	2-story sfr w/	2017
New	Approved basic 16-121092 BP	2015 IRC	Plan# Okanogan	2-story sfr w/a	2017
New	Approved basic 16-120404 BP	2015 IRC	Plan# Chelan	2-story sfr w/atta	2017
New	Approved basic 17-103126 BP	2015 IRC	Plan# Paradise 4	2-story sfr w/	2017
New	Approved basic 16-119392 BP	2015 IRC	Plan# Blake	2-story sfr w/attac	2017
New	Approved basic 16-113588 BP	2015 IRC	Plan# 473 A	2-story w/attached gara	2017
New	Approved basic 16-116042 BP	2015 IRC	Plan# 447 A	2-story sfr w/attach	2017
New	Approved basic 16-113444 BP	2015 IRC	Plan# 474 A	2-story w/attached g	2017
New	Approved basic 16-120573 BP	2015 IRC	Plan# 447 B	2-story sfr w/ attach	2017
New	Approved basic 17-103476 BP	2015 IRC	Plan# Paradise B	2-story sfr w/i	2017
New	Approved basic 16-119392 BP	2015 IRC	Plan# Blake	2-story sfr w/attac	2017
New	Approved basic 17-103126 BP	2015 IRC	Plan# Paradise 4	2-story sfr w/	2017
New	Approved basic 16-116041 BP	2015 IRC	Plan# 456 A	2-story sfr w/attache	2017
New	Approved basic 16-113281 BP	2015 IRC	Plan# 417 F	2-story w/attached gar	2017
New	Approved basic 16-113482 BP	2015 IRC	Plan# 424 E	2-story w/attached gara	2017
New	Approved basic 16-120573 BP	2015 IRC	Plan# 447 B	2-story sfr w/ attach	2017
New	Approved basic 16-120404 BP	2015 IRC	Plan# Chelan	2-story sfr w/atta	2017
New	Approved basic 17-103126 BP	2015 IRC	Plan# Paradise 4	2-story sfr w/	2017
New	Approved basic 16-119392 BP	2015 IRC	Plan# Blake	2-story sfr w/attac	2017
New	Approved basic 16-116041 BP	2015 IRC	Plan# 456 A	2-story sfr w/attache	2017
New	Approved basic 16-113482 BP	2015 IRC	Plan# 424 E	2-story w/attached gara	2017
New	Approved basic 16-113357	2015 IRC	Plan# 456 E	2-story w/attached gara	2017
New	Approved basic 16-113281	2015 IRC	Plan# 417 F	2-story w/attached gara	2017
New	Approved basic 16-120404 BP	2015 IRC	Plan# Chelan	2-story sfr w/atta	2017
New	Approved basic 16-121092 BP	2015 IRC	Plan# Okanogan	2-story sfr w/a	2017
New	Approved basic 17-103126 BP	2015 IRC	Plan# Paradise 4	2-story sfr w/	2017
New	Approved basic 16-115149 BP	2015 IRC	Plan# Windom C/D	2-story sfr w/finished k	2017

Accessory Dwelling Units

Index # - File Name: 1.0022 - Single Family Dwellings Data\_Snohomish County.pdf

New	Approved basic 16-115668 BP	2015 IRC	Plan# Aspen C	2-story sfr w/finished ba	2017
New	Approved basic 16-115669 BP	2015 IRC	Plan# Aspen D	2-story sfr w/finished baser	2017
New	Approved basic 16-115668 BP	2015 IRC	Plan# Aspen C	2-story sfr w/finished ba	2017
New	Approved basic 16-115149 BP	2015 IRC	Plan# Windom C/D	2-story sfr w/finished	2017
New	Approved Basic 17-106874 BP	2015 IRC	Plan # 2138	2138sf 2 story	2017
New	Approved Basic 17-106824 BP	2015IRC	Plan 2103 The Benson	two story SFR with at	2017
New	Approved Basic 17-106874 BP	2015 IRC	Plan # 2138	2138sf 2 story	2017
New	Approved Basic 17-106824 BP	2015IRC	Plan 2103 The Benson	two story SFR with at	2017
New	Approved Basic 17-106874 BP	2015 IRC	Plan # 2138	2138sf 2 story	2017
New	Approved Basic 17-106824 BP	2015IRC	Plan 2103 The Benson	two story SFR with at	2017
New	Approved Basic 17-106874 BP	2015 IRC	Plan # 2138	2138sf 2 story	2017
New	Approved Basic 17-106824 BP	2015IRC	Plan 2103 The Benson	two story SFR with at	2017
New	Approved Basic 17-106874 BP	2015 IRC	Plan # 2138	2138sf 2 story single family re	2017
New	Approved Basic 17-106824 BP	2015IRC	Plan 2103 The Benson	two story SFR with at	2017
New	Approved basic 16-118029 BP	2015 IRC	Plan# 1795-16	2-story sfr w/a	2017
New	Approved Basic 17 109866BP	2015 IRC	plan 2001. 2001 Sq. Ft	2 story home with attached gi	2017
New	Approved Basic 17 109866BP	2015 IRC	plan 2001. 2001 Sq. Ft	2 story home with attached gi	2017
New	Approved Basic 17109460 BP	2015 IRC	PLAN# 1856-2015	1856sf tw	2017
New	Approved Basic 17109460 BP	2015 IRC	PLAN# 1856-2015	1856sf tw	2017
New	Approved Basic 17-111587BP	2015 IRC	PLAN:1968	1968sf two story SFR with attache	2017
New	Approved Basic 17109460 BP	2015 IRC	PLAN# 1856-2015	1856sf two st	2017
New	Approved Basic 17-111587BP	2015 IRC	PLAN:1968	1968sf two story SFR with	2017
New	Approved Basic 17109460 BP	2015 IRC	PLAN# 1856-2015	1856sf two :	2017
New	Approved Basic 17-111587BP	2015 IRC	PLAN:1968	1968sf two story SFR with	2017
New	Approved Basic 17109460 BP	2015 IRC	PLAN# 1856-2015	1856sf two	2017
New	Approved Basic 17-111587BP	2015 IRC	PLAN:1968	1968sf two story SFR with	2017
New	Approved Basic 17109460 BP	2015 IRC	PLAN# 1856-2015	1856sf two	2017
New	Approved Basic 17-109409BP	2015 IRC	PLAN# 1708-2015	1708sf two stor	2017
New	Approved Basic 17-109422	2015 IRC	PLAN# 2417-2015	2417sf two st	2017
New	Approved basic 16-119384 BP	2015 IRC	Plan# 2552	2-story sfr w/base	2017
New	Approved Basic 17 113549 BP	2015 IRC 3006	3006 Sq. Ft. SF		2017
New	Approved basic 16-119384 BP	2015 IRC	Plan# 2552	2-story sfr w/base	2017
New	Approved Basic 17 113549 BP	2015 IRC 3006	3006 Sq. Ft. SF		2017
New	Approved basic 16-119384 BP	2015 IRC	Plan# 2552	2-story sfr w/base	2017
New	Approved Basic 17 113549 BP	2015 IRC 3006	3006 Sq. Ft. SF		2017
New	Approved basic 16-119384 BP	2015 IRC	Plan# 2552	2-story sfr w/base	2017
New	Approved Basic 17 113549 BP	2015 IRC 3006	3006 Sq. Ft. SF		2017
New	Approved basic 16-119384 BP	2015 IRC	Plan# 2552	2-story sfr w/base	2017
New	New SFR				2017
New	Approved basic 17-105280 BP	2015 IRC	Plan# 2041 Pratt	2-story sfr w/attach	2017
New	Approved basic 17-105279 BP	2015 IRC	Plan# 2124 Concord	2-story sfr w/a	2017
New	Approved basic 17-105279 BP	2015 IRC	Plan# 2124 Concord	2-story sfr w/a	2017
New	Approved basic 17-105280 BP	2015 IRC	Plan# 2041 Pratt	2-story sfr w/attach	2017
New	Approved basic 17-105279 BP	2015 IRC	Plan# 2124 Concord	2-story sfr w/a	2017
New	Approved basic 17-105279 BP	2015 IRC	Plan# 2124 Concord	2-story sfr w/a	2017

Accessory Dwelling Units

Index # - File Name: 1.0022 - Single Family Dwellings Data\_Snohomish County.pdf

New	Approved basic	17-105279 BP	2015 IRC	Plan# 2124 Concord	2-story sfr w/a	2017
New	Approved basic	17-105279 BP	2015 IRC	Plan# 2124 Concord	2-story sfr w/a	2017
New	Approved basic	17-105279 BP	2015 IRC	Plan# 2124 Concord	2-story sfr w/a	2017
New	Approved basic	17-105279 BP	2015 IRC	Plan# 2124 Concord	2-story sfr w/a	2017
New	Approved basic	17-105280 BP	2015 IRC	Plan# 2041 Pratt	2-story sfr w/attach	2017
New	Approved basic	17-105280 BP	2015 IRC	Plan# 2041 Pratt	2-story sfr w/attach	2017
New	Approved basic	17-105280 BP	2015 IRC	Plan# 2041 Pratt	2-story sfr w/attach	2017
New	Approved basic	17-105280 BP	2015 IRC	Plan# 2041 Pratt	2-story sfr w/attach	2017
New	Approved basic	17-105280 BP	2015 IRC	Plan# 2041 Pratt	2-story sfr w/attach	2017
New	Approved basic	17-105280 BP	2015 IRC	Plan# 2041 Pratt	2-story sfr w/attach	2017
New	Approved basic	17-105280 BP	2015 IRC	Plan# 2041 Pratt	2-story sfr w/attach	2017
New	Approved basic	17-105280 BP	2015 IRC	Plan# 2041 Pratt	2-story sfr w/attach	2017
New	Approved basic	17-105280 BP	2015 IRC	Plan# 2041 Pratt	2-story sfr w/attach	2017
New	Approved basic	17-105280 BP	2015 IRC	Plan# 2041 Pratt	2-story sfr w/attach	2017
New	Approved basic	17-105280 BP	2015 IRC	Plan# 2041 Pratt	2-story sfr w/attach	2017
New	Approved basic	17-105280 BP	2015 IRC	Plan# 2041 Pratt	2-story sfr w/attach	2017
New	Approved basic	17-105280 BP	2015 IRC	Plan# 2041 Pratt	2-story sfr w/attach	2017
New	Approved basic	17-105280 BP	2015 IRC	Plan# 2041 Pratt	2-story sfr w/attach	2017
New	Approved basic	17-105280 BP	2015 IRC	Plan# 2041 Pratt	2-story sfr w/attach	2017
New	Approved basic	16-113276 BP	2015 IRC	Plan# Chelan II C	2-story sfr w/attached	2017
New	Approved basic	16-113033 BP	2015 IRC	Plan# Rainier D	2-story sfr w/attached g	2017
New	Approved basic	16-113330 BP	2015 IRC	Plan# Trafton D	2-story sfr w/attached g	2017
New	Approved Basic	16-113032 BP	2015 IRC	Plan# Rainier C	2-story sfr w/attached g	2017
New	Approved basic	16-113278 BP	2015 IRC	Plan# Chelan II D	2-story sfr w/attached gara	2017
New	Approved basic	16-113033 BP	2015 IRC	Plan# Rainier D	2-story sfr w/attached g	2017
New	Approved basic	16-109158 BP	2015 IRC	Plan# Kimball C	2-story sfr w/attached	2017
New	Approved basic	16-113867 BP	2015 IRC	Plan# Newhalem D	2-story sfr w/attache	2017
New	Approved basic	16-113276 BP	2015 IRC	Plan# Chelan II C	2-story sfr w/attached	2017
New	Approved basic	16-113328 BP	2015 IRC	Plan# Trafton C	2-story sfr w/attached	2017
New	Approved basic	17-103304 BP	2015 IRC	Plan# Poplar D	2-story sfr w/attache	2017
New	Approved basic	16-113867 BP	2015 IRC	Plan# Newhalem D	2-story sfr w/attache	2017
New	Approved basic	17-103303 BP	2015 IRC	Plan# Poplar C	2-story sfr w/attached	2017
New	Approved basic	16-113033 BP	2015 IRC	Plan# Rainier D	2-story sfr w/attached g	2017
New	Approved basic	16-109158 BP	2015 IRC	Plan# Kimball C	2-story sfr w/attached	2017
New	Approved basic	16-113867 BP	2015 IRC	Plan# Newhalem D	2-story sfr w/attache	2017
New	Approved Basic	16-113032 BP	2015 IRC	Plan# Rainier C	2-story sfr w/attached g	2017
New	Approved basic	16-121324 BP	2015 IRC	Plan# Newhalem C Daylight	2-stc	2017
New	Approved basic	16-113328 BP	2015 IRC	Plan# Trafton C	2-story sfr w/attached	2017
New	Rambler w/attached garage		2015 IRC			2017
New	Single Story sfr		2015 IRC			2017
New	single story sfr with attached garage		2015 IRC			2017
New	New 2,065 sf rambler with 570 sf garage and 160 sf porch					2017
New	Rambler w/attached garage		2015 IRC			2017
New	1633 sq. ft. single story sfr with 450 sq. ft. attached garage and cov d deck					2017
New	New 1633 sf rambler with 450 sf garage and 160 sf covered porch					2017
New	Rambler w/attached garage		2015 IRC			2017
New	Accessory Apartment: residential building permit to construct detached AA					2017
New	2 story sfr with attached garage		2015 IRC			2017
New	Manufactured home: new 2016 double wide Fleetwood 26 x 48					2017
New	Approved basic	16-114915 BP	2015 IRC	Plan# G251_C	2-story sfr w/atta	2017
New	Approved basic	16-114914 BP	2015 IRC	Plan# G251_B	2-story sfr w/atta	2017



Accessory Dwelling Units

Index # - File Name: 1.0022 - Single Family Dwellings Data\_Snohomish County.pdf

New	2 story sfr w/attached garage					2017
New	Approved basic 16-114439 BP	2015 IRC	Plan# G271-C	2-story sfr w/		2017
New	Approved basic 16-114914 BP	2015 IRC	Plan# G251_B	2-story sfr w/atta		2017
New	Approved basic 16-114915 BP	2015 IRC	Plan# G251_C	2-story sfr w/atta		2017
New	2 story sfr w/attached garage					2017
New	Approved basic 16-114912 BP	2015 IRC	Plan# G251_A	2-story sfr w/at		2017
New	Two story SFR with attached Garage					2017
New	Two story SFR with attached Garage					2017
New	Approved basic 16-114914 BP	2015 IRC	Plan# G251_B	2-story sfr w/atta		2017
New	2 story sfr w/attached garage					2017
New	Approved basic 16-114439 BP	2015 IRC	Plan# G271-C	2-story sfr w/		2017
New	2 story sfr w/attached garage					2017
New	Approved basic 16-111825 BP	2015 IRC	Plan# G271	2-story w/attached g		2017
New	Approved basic 16-111825 BP	2015 IRC	Plan# G271	2-story w/attached g		2017
New	Approved basic 16-114439 BP	2015 IRC	Plan# G271-C	2-story sfr w/		2017
New	2 story sfr w/attached garage					2017
New	2 story sfr w/attached garage					2017
New	2 story SFR with attached garage.					2017
New	SFR: new home, 2 story with attached 2 car garage, 5 bedroom					2017
New	Two story SFR with attached Garage					2017
New	Approved basic 16-111825 BP	2015 IRC	Plan# G271	2-story w/attached g		2017
New	Two story SFR with attached Garage					2017
New	Approved basic 16-114894 BP	2015 IRC	Plan# G222_A	2-story sfr w/		2017
New	Two story SFR with attached Garage					2017
New	SFR: new home, 2 story with attached 2 car garage					2017
New	Approved basic 16-114439 BP	2015 IRC	Plan# G271-C	2-story sfr w/		2017
New	2 story SFR with attached garage.					2017
New	Approved basic 16-111825 BP	2015 IRC	Plan# G271	2-story w/attached g		2017
New	Approved basic 16-114894 BP	2015 IRC	Plan# G222_A	2-story sfr w/		2017
New	Approved basic 16-114912 BP	2015 IRC	Plan# G251_A	2-story sfr w/at		2017
New	Approved basic 16-114438 BP	2015 IRC	Plan# G271-B	2-story sfr w/		2017
New	Approved basic 16-114439 BP	2015 IRC	Plan# G271-C	2-story sfr w/		2017
New	Approved basic 16-114438 BP	2015 IRC	Plan# G271-B	2-story sfr w/		2017
New	2 story sfr w/attached garage					2017
New	Approved basic 16-114894 BP	2015 IRC	Plan# G222_A	2-story sfr w/		2017
New	2 story sfr w/attached garage					2017
New	2 story sfr w/attached garage					2017
New	2 story sfr w/attached garage					2017
New	Approved basic 16-114439 BP	2015 IRC	Plan# G271-C	2-story sfr w/		2017
New	SFR: new home, 2 story with attached 2 car garage					2017
New	New SFR					2017
New	Approved basic 16-114439 BP	2015 IRC	Plan# G271-C	2-story sfr w/		2017
New	2 story sfr w/attached garage					2017
New	2 story sfr w/attached garage					2017
New	2 story sfr w/attached garage					2017
New	Approved basic 16-114912 BP	2015 IRC	Plan# G251_A	2-story sfr w/at		2017
New	Approved basic 16-114438 BP	2015 IRC	Plan# G271-B	2-story sfr w/		2017

Accessory Dwelling Units

Index # - File Name: 1.0022 - Single Family Dwellings Data\_Snohomish County.pdf

New	2 story sfr w/attached garage				2017
New	2 story sfr w/attached garage				2017
New	Approved basic 16-111597 BP	2015 IRC	Plan# 2494A	2-story w/attached	2017
New	Approved basic 16-120910 BP	2015 IRC	Plan#1836A	2-story sfr w/attach	2017
New	Approved basic 16-120912 BP	2015 IRC	Plan# 1836B	2-story sfr w/attachec	2017
New	Approved basic 16-118652 BP	2015 IRC	Plan# Jefferson C/D	2-story sfr w/at	2017
New	Approved basic 16-113274 BP	2015 IRC	Plan# Mason C	2-story sfr w/attached g	2017
New	Approved basic 16-114611 BP	2015 IRC	Plan# Blakely D	2-story sfr w/attached	2017
New	Approved basic 16-114005 BP	2015 IRC	Plan# Cascade C	2-story sfr w/attach	2017
New	Approved basic 16-107423 BP	2012 IRC	Plan# 3861	Rambler style sfr w/2nd	2017
New	Approved basic 14-112279 BP	2012 IRC	Plan# 3445	Rambler style sfr w/attach	2017
New	Approved basic 16-115668 BP	2015 IRC	Plan# Aspen C	2-story sfr w/finished ba:	2017
New	Approved basic 16-115149 BP	2015 IRC	Plan# Windom C/D	2-story sfr w/finish	2017
New	SFR: two story home with covered patio, (no garage) 3 bedrooms, 2.5 bath				2017
New	Two story SFR with attached Garage				2017
New	New 2208 s.f. SFR with attached garage				2017
New	Rambler w/attached garage				2017
New	Rambler w/attached garage				2017
New	Rambler w/attached garage				2017
New	New 2,292 SF, 1-story SFR with 595 SF attached garage and deck. 04/25/17 ebt - signed and noi				2017
New	Approved basic 16-120910 BP	2015 IRC	Plan#1836A	2-story sfr w/attach	2017
New	Approved basic 16-120912 BP	2015 IRC	Plan# 1836B	2-story sfr w/attachec	2017
New	Approved basic 16-120910 BP	2015 IRC	Plan#1836A	2-story sfr w/attach	2017
New	Approved basic 16-111597 BP	2015 IRC	Plan# 2494A	2-story w/attachec	2017
New	Approved basic 16-111955 BP	2015 IRC	Plan# 2501A	2-story w/attached g	2017
New	Approved basic 16-111598 BP	2015 IRC	Plan# 2494B	2-story w/attached	2017
New	Approved basic 16-111597 BP	2015 IRC	Plan# 2494A	2-story w/attachec	2017
New	Approved Basic #17-100313 BP	2015 IRC	Plan# 2501B	2-story sfr w/attache	2017
New	Approved basic 16-111598 BP	2015 IRC	Plan# 2494B	2-story w/attached	2017
New	Approved basic 16-111955 BP	2015 IRC	Plan# 2501A	2-story w/attached g	2017
New	Approved basic 16-121135 BP	2015 IRC	Plan# 2825A	2-story sfr w/attach	2017
New	Approved basic 16-114519 BP	2015 IRC	Plan# 2825C	2-story sfr w/atta	2017
New	Approved basic 16-121135 BP	2015 IRC	Plan# 2825A	2-story sfr w/attach	2017
New	Approved basic 16-113275 BP	2015 IRC	Plan# Mason D	2-story sfr w/attached g	2017
New	Approved basic 16-113278 BP	2015 IRC	Plan# Chelan II D	2-story sfr w/attached gara	2017
New	Approved Basic 16-112153 BP	2015 IRC	Plan# Baker C	2-story sfr w/attached gar	2017
New	Approved basic 16-114006 BP	2015 IRC	Plan# Cascade D	2-story sfr w/attached gar	2017
New	Approved basic 16-114005 BP	2015 IRC	Plan# Cascade C	2-story sfr w/attach	2017
New	Approved basic 16-112155 BP	2015 IRC	Plan# Baker D	2-story sfr w/attached ga	2017
New	Approved Basic 16-112153 BP	2015 IRC	Plan# Baker C	2-story sfr w/attached gar	2017
New	New 2-story 2,393 SF SFR with attached garage and covered deck, and a 702 SF carport, in 07-1:				2017
New	Approved basic 16-111597 BP	2015 IRC	Plan# 2494A	2-story w/attachec	2017
New	Approved basic 16-121135 BP	2015 IRC	Plan# 2825A	2-story sfr w/attach	2017
New	Approved basic 16-120910 BP	2015 IRC	Plan#1836A	2-story sfr w/attach	2017
New	Approved basic 16-120912 BP	2015 IRC	Plan# 1836B	2-story sfr w/attachec	2017
New	Approved basic 16-120912 BP	2015 IRC	Plan# 1836B	2-story sfr w/attachec	2017
New	Two story SFR with attached Garage				2017

Accessory Dwelling Units

Index # - File Name: 1.0022 - Single Family Dwellings Data\_Snohomish County.pdf

New	Two story SFR with attached Garage				2017
New	2 story sfr w\attached garage				2017
New	Approved basic 16-118185 BP	2015 IRC	Plan# 2537	2-story sfr w/	2017
New	Approved basic 16-115677 BP	2015 IRC	Plan# 3017C	2-story sfr w/attache	2017
New	Approved basic 16-111957 BP	2015 IRC	Plan# 2501B	2-story w/attached g	2017
New	Approved basic 16-115677 BP	2015 IRC	Plan# 3017C	2-story sfr w/attache	2017
New	340 square foot covered deck				2017
New	Approved basic 16-114079 BP	2015 IRC	Plan# 2766	2766 s.f. rambler w/att	2017
New	Two story SFR				2017
New	New 2-story, 2,204 SF SFR with a 456 SF attached garage and 55 SF covered deck.				2017
New	New 2,269 sq. ft SFR with 419 sq. ft. attached garage and 61 sq. ft. covered porch				2017
New	2112 sfr w/finished basement and attached garage				2017
New	Approved basic 16-107416 BP	2012 IRC	Plan# 2562	Rambler style sfr w/att	2017
New	Approved basic 16-107421 BP	2012 IRC	Plan# 3201	Rambler style sfr w/atta	2017
New	Approved basic 16-107423 BP	2012 IRC	Plan# 3861	Rambler style sfr w/2nd	2017
New	Approved basic 14-112279 BP	2012 IRC	Plan# 3445	Rambler style sfr w/attach	2017
New	Approved basic 16-107423 BP	2012 IRC	Plan# 3861	Rambler style sfr w/2nd	2017
New	Approved basic 14-112279 BP	2012 IRC	Plan# 3445	Rambler style sfr w/attach	2017
New	Approved basic 16-107423 BP	2012 IRC	Plan# 3861	Rambler style sfr w/2nd	2017
New	2508 square foot SFR with attached 768 square foot Garage				2017
New	SFR: rambler style home with attached garage, 3 bedrooms 2.5 baths				2017
New	2521 square foot SFR with attached Garage				2017
New	2318 square foot SFR with 666 square foot attached Garage				2017
New	New 2,057 sf rambler with 597 sf garage, 400 sf covered deck, 500 sf deck				2017
New	Approved basic 16-114079 BP	2015 IRC	Plan# 2766	2766 s.f. rambler w/att	2017
New	Approved Basic 17110802BP	2015 IRC	PLAN: 3428-2550 DL	3428sf three story	2017
New	Approved basic 16-114080 BP	2015 IRC	Plan# 2974	2-story sfr w/attached g	2017
New	Approved Basic 17110802BP	2015 IRC	PLAN: 3428-2550 DL	3428sf three story	2017
New	Approved basic 15-101179 BP	2012 IRC	Plan# 2807	2-story sfr w/attached g;	2017
New	Approved basic 16-108970 BP	2012 IRC	Plan# 2305-3 car	2-story sfr w	2017
New	Approved basic 16-114058 BP	2015 IRC	Plan# 2212	2212 s.f. rambler w/atl	2017
New	Approved basic 16-114080 BP	2015 IRC	Plan# 2974	2-story sfr w/attached g	2017
New	*****Approved Basic	16-114080-BP*****			2017
New	Approved basic 16-119361 BP	2015 IRC	Plan# 3212 A/C	2 story sfr w/attache	2017
New	New SFR				2017
New	Approved basic 16-114080 BP	2015 IRC	Plan# 2974	2-story sfr w/attached g	2017
New	A new 2,182 SF SFR with a 914 SF attached garage and covered/uncovered decks				2017
New	1976 24 X 28 Country Carrige Estates Double-wide Mobile Home				2017
New	3139 sq. ft. 2 story sfr with attached garage				2017
New	3177 sq. ft. 2 story sfr with attached garage	2015 IRC			2017
New	2 story home with finished basement and attached garage	2015 IRC			2017
New	New 2-story plus basement 3,363 SF SFR with 498 SF attached garage and covered deck.				2017
New	Approved Basic 17-106124 BP	2015 IRC	Plan 3271	two story SFR with attached 3-car ga	2017
New	Approved basic 16-114083 BP	2015 IRC	Plan# 3602 B	2-story sfr w/attached	2017
New	Approved Basic 17-106124 BP	2015 IRC	Plan 3271	two story SFR with attached 3-car g	2017
New	Approved basic 16-120669 BP	2015 IRC	Plan# 3044	2-story sfr w/ attache	2017
New	Approved basic 16-120708 BP	2015 IRC	Plan# 3484	2-story sfr w/attache	2017

Accessory Dwelling Units

Index # - File Name: 1.0022 - Single Family Dwellings Data\_Snohomish County.pdf

New	Approved Basic 17115412BP	2015 IRC	2766 Sq FT Rambler with attached gar	2017
New	New 2,797 sf SFR with basement			2017
New	New 2 story sfr w/attached garage			2017
New	Approved basic 16-118640 BP	2015 IRC	Plan# 3392 B 2 story w/finished	2017
New	Two story SFR with attached Garage			2017
New	Two story SFR with finished basement and attached garage			2017
New	Two story SFR with 770 square foot finished Basement and 449 square foot attached Garage			2017
New	Two story SFR with finished basement and attached garage			2017
New	Two story SFR with finished basement and attached garage			2017
New	New 2-story 3,257 SF SFR with finished basement, 449 SF attached garage and covered deck.			2017
New	Two story SFR with finished basement and attached garage			2017
New	Two story SFR with finished basement and attached garage			2017
New	Two story SFR with finished basement and attached garage			2017
New	New 2-story 2,797 SF SFR with finished basement, 437 SF attached garage, and covered deck.			2017
New	Two story SFR with finished basement and attached garage			2017
New	New 3,363 sf 2-story SFR with basement			2017
New	New 3,264 SF 3-story including finished basement, SFR. 449 SF attached garage and 293 SF cove			2017
New	Two story SFR with finished basement and attached garage			2017
New	Approved basic 16-114079 BP	2015 IRC	Plan# 2766 2766 s.f. rambler w/att	2017
New	Approved basic 16-118221 BP	2015 IRC	Plan# 3392 A 2 story w/finished	2017
New	Approved basic 16-118640 BP	2015 IRC	Plan# 3392 B 2 story w/finished	2017
New	Approved basic 16-118221 BP	2015 IRC	Plan# 3392 A 2 story w/finished	2017
New	Approved basic 16-118640 BP	2015 IRC	Plan# 3392 B 2 story w/finished	2017
New	Approved basic 16-118221 BP	2015 IRC	Plan# 3392 A 2 story w/finished	2017
New	Approved basic 16-118640 BP	2015 IRC	Plan# 3392 B 2 story w/finished	2017
New	Approved basic 16-118221 BP	2015 IRC	Plan# 3392 A 2 story w/finished	2017
New	Approved basic 16-120671 BP	2015 IRC	Plan# 3516 2-story sfr w/attached	2017
New	Approved basic 16-120708 BP	2015 IRC	Plan# 3484 2-story sfr w/attache	2017
New	Approved basic 16-114058 BP	2015 IRC	Plan# 2212 2212 s.f. rambler w/at	2017
New	Approved basic 16-114079 BP	2015 IRC	Plan# 2766 2766 s.f. rambler w/att	2017
New	Approved Basic 17-110805BP	2015 IRC	PLAN: 3023 3023sf two story S	2017
New	Approved basic 16-120708 BP	2015 IRC	Plan# 3484 2-story sfr w/attache	2017
New	Approved basic 16-110261 BP	2012 IRC	Plan# 3876 2-story sfr w/attach	2017
New	Approved basic 16-114058 BP	2015 IRC	Plan# 2212 2212 s.f. rambler w/at	2017
New	New 2724 sq ft SFR with attached garage and covered porches			2017
New	Approved basic 16-114079 BP	2015 IRC	Plan# 2766 2766 s.f. rambler w/att	2017
New	Approved basic 16-120669 BP	2015 IRC	Plan# 3044 2-story sfr w/ attache	2017
New	Approved Basic 16-119385 BP	2015 IRC	Plan# DL3416-03AB Rambler w/fi	2017
New	Approved basic 17-103633 BP	2015 IRC	Plan 2588-03AB Rambler w/attached gara	2017
New	Approved Basic 17-109019 BP	2015 IRC	Plan# 3588-03AB 3588sf two story SFR	2017
New	Approved Basic 17-112334 BP	2015 IRC	PLAN: 3134-03CD RV 3134sf twc	2017
New	Approved Basic 17109487BP	2015 IRC	2768-03AB 2768Sq. Ft. SFR with 3 car attached gar	2017
New	Approved basic 17-103633 BP	2015 IRC	Plan 2588-03AB Rambler w/attached gara	2017
New	Approved basic 17-103633 BP	2015 IRC	Plan 2588-03AB Rambler w/attached gara	2017
New	New 2-story, 2,677 SF SFR with 722 SF attached garage and 156 SF covered deck. 30 day extens			2017
New	2,644 sf 2-story SFR w/ 758 sf finished basement and 497 sf attached garage			2017
New	New SFR			2017

Accessory Dwelling Units

Index # - File Name: 1.0022 - Single Family Dwellings Data\_Snohomish County.pdf

New	2 Story SFR w/attached garage				2017
New	New SFR				2017
New	New 2,555 2-story SFR with 449 sf garage				2017
New	Two story SFR with attached Garage				2017
New	2 story w/158 s.f. finished basement and attached garage				2017
New	Approved basic 16-118221 BP	2015 IRC	Plan# 3392 A	2 story w/finished	2017
New	Two story SFR with attached Garage				2017
New	Two story SFR with attached Garage				2017
New	New 2-story 2,632 SF SFR with 498 SF attached garage and covered deck.				2017
New	Two story SFR with attached Garage				2017
New	New 2,414 sf 2-story SFR with 464 sf garage and 50 sf covered porch				2017
New	Two story SFR with attached Garage				2017
New	Two story SFR with attached Garage				2017
New	Approved Basic 16-113810 BP	2015 IRC		Plan # Interurban Revis	2017
New	Approved Basic 16-113810 BP	2015 IRC		Plan # Interurban Revis	2017
New	Two story SFR with attached garage.				2017
New	Two story SFR with attached Garage				2017
New	Two story SFR with attached Garage				2017
New	Two story SFR with attached Garage				2017
New	Two story SFR with attached Garage				2017
New	Two story SFR with attached Garage				2017
New	Two story SFR with attached Garage				2017
New	New 2740 sq ft two story SFR with 497 sq ft and 230 sq ft covered porch				2017
New	New 2,532 sf 2-story SFR with 498 sf garage and 230 sf covered porch				2017
New	2,065 sf 2-story SFR w/ 787 sf finished basement and 426 sf attached garage				2017
New	SFR: 2 story with finished basement and attached 2 car garage				2017
New	Two story SFR with attached Garage				2017
New	Two story SFR with attached Garage				2017
New	New 1,833 SF 2-story SFR, with attached garage and covered porches.				2017
New	New SFR				2017
New	2 story sfr w/finished basement & attached garage				2017
New	New 3,587 sf 2-story SFR w/basement, 449 sf garage				2017
New	2 story w/finished basement & attached garage				2017
New	2 story sfr w/attached garage				2017
New	New 2,715 sf 2-story sfr with 511 sf garage and 420 sf of covered porch				2017
New	Approved basic 16-115219 BP	2015 IRC	Plan# 2165	2-story SFR w/ attached ga	2017
New	New 3,120 sq. ft. SFR with 792 sq. ft. garage and 228 sq. ft. covered porch.				2017
New	Approved basic 16-118028 BP	2015 IRC	Plan# 1589	2-story sfr w/atta	2017
New	Approved basic 16-118028 BP	2015 IRC	Plan# 1589	2-story sfr w/atta	2017
New	Approved basic 16-118030 BP	2015 IRC	Plan# 2052-16	2-story sfr w/a	2017
New	Approved basic 16-118029 BP	2015 IRC	Plan# 1795-16	2-story sfr w/a	2017
New	Approved basic 16-118029 BP	2015 IRC	Plan# 1795-16	2-story sfr w/a	2017
New	Two story SFR with attached Garage				2017
New	Airport Influence Area Disclosure Notice AFN: 201708040424			New 3211sf SFR with 796sf attach	2017
New	722 square foot AA with 813 attached Garage				2017
New	New 1,280 sf SFR with 138 sf unfinished basement and 1035 sf garage below				2017
New	Expiration date extended 120 days per Emergency Ordinance 20-027			New 2,962 sf rambler with	2017

Accessory Dwelling Units

Index # - File Name: 1.0022 - Single Family Dwellings Data\_Snohomish County.pdf

New	Approved basic 17-100203 BP	2015 IRC	Plan# 2254 (25#)	Rambler v	2017
New	New 4835 sq ft SFR with attached 803 sq ft garage, 264 sq ft carport, and 743 sq ft covered deck				2017
New	This application was sent a notice of pending application expiration on April 11, 2017, and will e				2017
New	New 5,206 sf residence with 1080 sf garage and 1674 sf covered porch				2017
New	SFR: rambler style home with attached 3-car garage, 4 bedrooms/2.5 baths				2017
New	2 story duplex w/attached garage				2017
New	Two story SFR with attached Garage				2017
New	Approved basic 16-114982 BP	2015 IRC	Plan# 3072	2-story sfr w/attached {	2017
New	SFR: Rambler style home w/ daylight basement and attached 3 car garage				2017
New	SFR: Rambler style home w/ daylight basement and attached 3 car garage				2017
New	1787 square foot with 910 square foot finished Basement				2017
New	1787 square foot SFR with 910 square foot finished Basement with attached Garage				2017
New	Approved basic 16-103455 BP	2012 IRC	Plan# 2664	2-story sfr w/attac	2017
New	Approved basic 16-103455 BP	2012 IRC	Plan# 2664	2-story sfr w/attac	2017
New	New SFR with attached garage and finished daylight basement. 2547 sq ft living space. 4035 sq f				2017
New	New SFR with attached garage and finished daylight basement. 2747 sq ft living space. 3735 sq				2017
New	New 2,747 SF 2-story (finished basement and main) SFR, with 697 SF attached garage. Covered :				2017
New	New 2,685 sf SFR with 716 sf garage, 277 sf covered porch, and 140 sf deck				2017
New	2556 square foot SFR with attached Garage				2017
New	New 2,835 sf 2-story SFR with 769 sf garage and 428 sf covered porch				2017
New	Approved basic 16-114080 BP	2015 IRC	Plan# 2974	2-story sfr w/attached {	2017
New	single story sfr with attached garage, covered porch and unheated loft storage				2017
New	2545 rambler w/attached garage				2017
New	New 2,805 SF home with 660 SF attached garage and 404 SF covered deck.				2017
New	New 2202 sq. ft. SFR with 968 sq. ft. garage and 77 sq. ft. covered deck.				2017
New	2332 square foot SFR with attached Garage				2017
New	New 4,458 SF, 2-story and unfinished basement SFR with 1,096 SF attached garage and 510 SF c				2017
New	2018 26 8 X 64 square foot Double-Wide Mobile Home				2017
New	New 4,273 sq ft SFR with 1248 sq ft garage and 446 sq ft covered deck				2017
New	SFR: 2 story style home with 4 car garage and covered back patio				2017
New	New 2- story SFR with attached garage				2017
New	New 2,781 sf 2-story SFR, 680 sf garage and 260 sf covered porch				2017
New	New 2-story SFR with attached garage Do not final structure w/o Sno Health District approval.				2017
New	New 3,099 sf 1-story w/basement SFR, 642 sf garage, 84 sf covered porch, and 204 sf deck				2017
New	Approved basic 17-105279 BP	2015 IRC	Plan# 2124 Concord	2-story sfr w/a	2017
New	Approved Basic 17-105282 BP	2015 IRC	Plan# 1935 Parrington	2-	2017
New	Approved Basic 17-105282 BP	2015 IRC	Plan# 1935 Parrington	2-story sfr w/attached ga	2017
New	Approved Basic 17-105282 BP	2015 IRC	Plan# 1935 Parrington	2-story sfr w/attac	2017
New	Approved Basic 17-105280 BP	2015 IRC	Plan# 2041 Pratt	2-story sfr w/attach	2017
New	Approved basic 16-113033 BP	2015 IRC	Plan# Rainier D	2-story sfr w/attached g	2017
New	Approved basic 16-113867 BP	2015 IRC	Plan# Newhalem D	2-story sfr w/attache	2017
New	Approved basic 16-113328 BP	2015 IRC	Plan# Trafton C	2-story sfr w/attached	2017
New	Approved Basic 16-113032 BP	2015 IRC	Plan# Rainier C	2-story sfr w/attached g	2017
New	Approved basic 16-109158 BP	2015 IRC	Plan# Kimball C	2-story sfr w/attached	2017
New	Approved basic 16-113033 BP	2015 IRC	Plan# Rainier D	2-story sfr w/attached g	2017
New	Approved basic 16-109161 BP	2015 IRC	Plan# Kimball D	2-story sfr w/attached	2017
New	2 story 3739 sf SFR with attached garage				2017

Accessory Dwelling Units

Index # - File Name: 1.0022 - Single Family Dwellings Data\_Snohomish County.pdf

New	New 2721 sq ft single family residence with attached 903 sq ft garage				2017
New	New SFR NSF Check - Accept only cash, bank draft, money order or credit card.				2017
New	Approved Basic 17-106927 BP	2015 IRC	Plan# 3019	3019sf two story SFR	2017
New	Approved Basic 17 114922BP	2015 IRC	2313 -#38	2313 Sq. Ft. SFR with attached garage.	2017
New	Approved Basic 17 114919 BP	205 IRC	2578 SQ Ft.	SFR with attached garage.	2017
New	Approved Basic 17-106927 BP	2015 IRC	Plan# 3019	3019sf two story SFR	2017
New	Approved Basic 17 114922BP	2015 IRC	2313 -#38	2313 Sq. Ft. SFR with attached garage.	2017
New	Approved Basic 17-111513 BP	IRC 2015	PLAN: 2458-38#	2458sf rambler with	2017
New	Approved Basic 17-106927 BP	2015 IRC	Plan# 3019	3019sf two story SFR	2017
New	Approved Basic 17 114919 BP	205 IRC	2578 SQ Ft.	SFR with attached garage.	2017
New	Approved Basic 17 114859	2015 IRC	PLAN 3017	2578 Sq. FT. SFR with attached garage.	2017
New	Approved basic 16-113573 BP	2015 IRC	Plan# 480 B	2-story w/attached garage	2017
New	Approved basic 16-113358BP	2015 IRC	Plan# 456 F	2-story w/attached garage	2017
New	Approved basic 16-113589 BP	2015 IRC	Plan# 473 B	2-story w/attached garage	2017
New	Approved basic 16-113484 BP	2015 IRC	Plan# 423 F	2-story w/attached garage	2017
New	Approved basic 16-113572 BP	2015 IRC	Plan# 480 A	2-story w/attached garage	2017
New	Approved basic 16-116041 BP	2015 IRC	Plan# 456 A	2-story sfr w/attached garage	2017
New	Approved basic 16-113281	2015 IRC	Plan# 417 F	2-story w/attached garage	2017
New	Approved basic 16-113486 BP	2015 IRC	Plan# 423 G	2-story w/attached garage	2017
New	Approved basic 16-113589 BP	2015 IRC	Plan# 473 B	2-story w/attached garage	2017
New	Approved basic 16-113588 BP	2015 IRC	Plan# 473 A	2-story w/attached garage	2017
New	Approved basic 16-113358BP	2015 IRC	Plan# 456 F	2-story w/attached garage	2017
New	Two story SFR with attached Garage				2017
New	6-20-19 esp One time 30day extension Two story SFR with attached Garage				2017
New	Two story SFR with attached Garage				2017
New	Two story SFR with attached Garage				2017
New	Two story SFR with attached Garage				2017
New	Two story SFR with attached Garage				2017
New	2714 square foot SFR with attached Garage				2017
New	3108 square foot SFR with 1044 square foot attached Garage				2017
New	Approved basic 16-112018 BP	2015 IRC	Plan# Trafton C Daylight	2-story w/finished	2017
New	Approved basic 17-100648 BP	2015 IRC	Plan# Armstrong Daylight C/D	2story sfr w	2017
New	Approved basic 16-108242 BP	2015 IRC	Plan# Cavanaugh C/D Daylight	2-story sfr w	2017
New	New 3,072 sq. ft. SFR with 785 sq. ft. attached garage and 118 sq. ft. covered deck.			Approved I	2017
New	Construction of new 2282 s.f. SFR with 1134 s.f. attached garage and 396 s.f. covered deck.				2017
New	28 X 56 Double-wide Mobile Home for Temporary Dwelling				2017
New	New 2-story, 2,343 SF SFR with 518 SF attached garage, 28 SF covered deck, and 57 SF deck. (33				2017
New	New 1,895 SF SFR with 529 SF attached garage, 28 SF covered deck, and 57 SF deck. (130 CY cut				2017
New	2 story sfr w/attached garage				2017
New	2 story sfr w/attached garage				2017
New	2 story sfr w/attached garage				2017
New	Approved basic 16-121137 BP	2015 IRC	Plan# 2825C	2-story sfr w/attac	2017
New	Approved basic 17-100313 BP	2015 IRC	Plan# 2501B	2-story sfr w/attache	2017
New	Approved basic 16-111598 BP	2015 IRC	Plan# 2494B	2-story w/attached	2017
New	Approved basic 17-100312 BP	2015 IRC	Plan# 2501A	2-story sfr w/attache	2017
New	Approved basic 16-111597 BP	2015 IRC	Plan# 2494A	2-story w/attache	2017
New	2 story sfr w/attached garage				2017

Accessory Dwelling Units

Index # - File Name: 1.0022 - Single Family Dwellings Data\_Snohomish County.pdf

New	Approved basic 17-100304 BP	2015 IRC	Plan# 3222B	2-story sfr w/finishec	2017
New	Approved Basic 17-108108BP	2015 IRC	PLAN# 3395A	2 Story SFR w/Baser	2017
New	Approved basic 17-100303 BP	2015 IRC	Plan# 3222A	2-story sfr w/finishe	2017
New	Approved basic 17-100303 BP	2015 IRC	Plan# 3222A	2-story sfr w/finishe	2017
New	Approved basic 17-100303 BP	2015 IRC	Plan# 3222A	2-story sfr w/finishe	2017
New	Approved basic 17-100312 BP	2015 IRC	Plan# 2501A	2-story sfr w/attache	2017
New	Approved basic 16-121137 BP	2015 IRC	Plan# 2825C	2-story sfr w/attac	2017
New	Approved basic 16-111598 BP	2015 IRC	Plan# 2494B	2-story w/attached	2017
New	Approved basic 16-121137 BP	2015 IRC	Plan# 2825C	2-story sfr w/attac	2017
New	Approved basic 17-100313 BP	2015 IRC	Plan# 2501B	2-story sfr w/attache	2017
New	Approved basic 16-121135 BP	2015 IRC	Plan# 2825A	2-story sfr w/attache	2017
New	Approved basic 16-111597 BP	2015 IRC	Plan# 2494A	2-story w/attache	2017
New	Approved basic 16-121135 BP	2015 IRC	Plan# 2825A	2-story sfr w/attache	2017
New	2-story sfr w/attached garage				2017
New	new 3070 sq. ft. 2 story sfr with attached garage	2015 IRC			2017
New	Approved basic 16-120573 BP	2015 IRC	Plan# 447 B	2-story sfr w/ attach	2017
New	Approved basic 16-113484 BP	2015 IRC	Plan# 423 F	2-story w/attached gara	2017
New	Approved basic 17-102009 BP	2015 IRC	Plan# 481 A	2-story sfr w/attached g	2017
New	Approved basic 16-113486 BP	2015 IRC	Plan# 423 G	2-story w/attache	2017
New	Approved basic 16-113572 BP	2015 IRC	Plan# 480 A	2-story w/attached gar	2017
New	Approved basic 16-113357	2015 IRC	Plan# 456 E	2-story w/attached gara	2017
New	Approved basic 17-102009 BP	2015 IRC	Plan# 481 A	2-story sfr w/attached g	2017
New	Approved basic 16-120573 BP	2015 IRC	Plan# 447 B	2-story sfr w/ attach	2017
New	Approved basic 16-113484 BP	2015 IRC	Plan# 423 F	2-story w/attached gara	2017
New	Approved basic 16-113281	2015 IRC	Plan# 417 F	2-story w/attached gara	2017
New	Approved basic 16-113358	2015 IRC	Plan# 456 F	2-story w/attached gara	2017
New	Approved basic 16-113281	2015 IRC	Plan# 417 F	2-story w/attached gara	2017
New	Approved basic 16-113357	2015 IRC	Plan# 456 E	2-story w/attached gara	2017
New	Approved Basic: 17-105992 BP	2015 IRC	Plan: Whatcom C/ D	2532 sf 2 story w/fin	2017
New	Approved Basic 17-108426	2015 IRC	PLAN: Barclay C/D	3280sf three s	2017
New	Approved Basic 17-111130 BP	2015 IRC	PLAN: Palmer II C/D	2451sf three sto	2017
New	Approved basic 16-115979 BP	2015 IRC	Plan# Amherst C/D	2-story sfr w/partial finishe	2017
New	Approved Basic 17-106270 BP	2015 IRC	Plan Kokanee C D	2 story sfr with daylight basen	2017
New	Approved basic 16-115149 BP	2015 IRC	Plan# Windom C/D	2-story sfr w/finish	2017
New	Approved Basic 17-108426	2015 IRC	PLAN: Barclay C/D	3280sf three s	2017
New	Approved basic 16-115149 BP	2015 IRC	Plan# Windom C/D	2-story sfr w/finished b	2017
New	Approved basic 16-121324 BP	2015 IRC	Plan# Newhalem C Daylight	2-stc	2017
New	Approved basic 16-112022 BP	2015 IRC	Plan# Trafton D Daylight	2-story w/finished	2017
New	Approved basic 17-100648 BP	2015 IRC	Plan# Armstrong Daylight C/D	2story sfr	2017
New	Approved basic 16-108242 BP	2015 IRC	Plan# Cavanaugh C/D Daylight	2-story sfr w	2017
New	Approved basic 16-121325 BP	2015 IRC	Plan# Newhalem D Daylight	2-stc	2017
New	Approved basic 16-112018 BP	2015 IRC	Plan# Trafton C Daylight	2-story	2017
New	Approved basic 17-100648 BP	2015 IRC	Plan# Armstrong Daylight C/D	2story sfr	2017
New	Approved basic 17-101561 BP	2015 IRC	Plan# Baker C/D Daylight	2story sfr w	2017
New	Approved basic 16-112022 BP	2015 IRC	Plan# Trafton D Daylight	2-story	2017
New	Approved Basic: 17-105992 BP	2015 IRC	Plan: Whatcom C/ D	2532 sf 2 story w/fin	2017
New	Approved Basic 17-106270 BP	2015 IRC	Plan Kokanee C D	2 story sfr with daylight basen	2017







Accessory Dwelling Units

Index # - File Name: 1.0022 - Single Family Dwellings Data\_Snohomish County.pdf

New	Approved basic 16-108597 BP	2015 IRC	Plan# Dayton C	2-story sfr w/attached g	2017
New	Approved basic 16-114006 BP	2015 IRC	Plan# Cascade D	2-story sfr w/attached gar	2017
New	Approved Basic 16-113032 BP	2015 IRC	Plan# Rainier C	2-story sfr w/attached g	2017
New	Approved basic 16-113330 BP	2015 IRC	Plan# Trafton D	2-story sfr w/attached g	2017
New	Approved basic 16-113033 BP	2015 IRC	Plan# Rainier D	2-story sfr w/attached g	2017
New	Approved basic 16-114005 BP	2015 IRC	Plan# Cascade C	2-story sfr w/attach	2017
New	Approved basic 16-108598 BP	2015 IRC	Plan# Dayton D	2-story sfr w/attached gar	2017
New	Approved basic 16-113328 BP	2015 IRC	Plan# Trafton C	2-story sfr w/attached	2017
New	Approved Basic 16-112153 BP	2015 IRC	Plan# Baker C	2-story sfr w/attached gar	2017
New	Approved basic 16-113033 BP	2015 IRC	Plan# Rainier D	2-story sfr w/attached g	2017
New	Approved basic 16-108632 BP	2015 IRC	Plan# Cavanaugh C/D	2-story sfr w/att	2017
New	Approved basic 16-108597 BP	2015 IRC	Plan# Dayton C	2-story sfr w/attached g	2017
New	Approved Basic 16-113032 BP	2015 IRC	Plan# Rainier C	2-story sfr w/attached g	2017
New	Approved basic 16-113328 BP	2015 IRC	Plan# Trafton C	2-story sfr w/attached	2017
New	Approved basic 16-118177 BP	2015 IRC	Plan# 2370	2-story sfr w/	2017
New	Approved Basic #17-106890 BP	2015 IRC	Plan: Campbell II C/D	1790sf two sto	2017
New	Approved Basic 17-107522 BP	2015 IRC	Plan Granite D	2 story sfr with atta	2017
New	Approved basic 16-116039 BP	2015 IRC	Plan# Hazelwood D	2-story sfr w/i	2017
New	Approved Basic #17-106890 BP	2015 IRC	Plan: Campbell II C/D	1790sf two sto	2017
New	Approved Basic 17-107522 BP	2015 IRC	Plan Granite D	2 story sfr with atta	2017
New	Approved basic 16-116037 BP	2015 IRC	Plan# Hazelwood C	2-story sfr w/a	2017
New	Approved basic 16-116039 BP	2015 IRC	Plan# Hazelwood D	2-story sfr w/a	2017
New	Approved Basic 17-107523 BP	2015 IRC	Plan Granite D	2 story sfr with atta	2017
New	Approved basic 16-116037 BP	2015 IRC	Plan# Hazelwood C	2-story sfr w/a	2017
New	Approved basic 17-109047 BP	2015 IRC	Plan # Chamberlain C/D	1,951 sf Two	2017
New	Approved basic 17-109047 BP	2015 IRC	Plan # Chamberlain C/D	1,951 sf Two	2017
New	Approved basic 17-109047 BP	2015 IRC	Plan # Chamberlain C/D	1,951 sf Two	2017
New	Approved Basic 17-107523 BP	2015 IRC	Plan Granite C	2 story sfr with atta	2017
New	Approved Basic #17-106890 BP	2015 IRC	Plan: Campbell II C/D	1790sf two sto	2017
New	Approved basic 16-116037 BP	2015 IRC	Plan# Hazelwood C	2-story sfr w/a	2017
New	Approved basic 17-109047 BP	2015 IRC	Plan # Chamberlain C/D	1,951 sf Two	2017
New	2 story sfr w/attached garage				2017
New	2018 27 X 56 Mobile Home				2017
New	Approved basic 16-114982 BP	2015 IRC	Plan# 3072	2-story sfr w/attached g	2017
New	1781 sf SFR with attached garage				2017
New	Approved basic 16-120708 BP	2015 IRC	Plan# 3484	2-story sfr w/attache	2017
New	Approved basic 16-120669 BP	2015 IRC	Plan# 3044	2-story sfr w/ attache	2017
New	Approved Basic 17-110805BP	2015 IRC	PLAN: 3023	3023sf two story S	2017
New	Approved basic 16-120708 BP	2015 IRC	Plan# 3484	2-story sfr w/attache	2017
New	3269 square foot SFR with unfinished Basement and attached Garage				2017
New	Approved basic 17-107308BP	2015 IRC	Plan 2515 A/B	2 story SFR with a	2017
New	Approved Basic 17-107158 BP	2015 IRC	Plan 2273D	2 story SFR with atl	2017
New	Approved Basic 17-112393 BP	2015 IRC	PLAN 2811 AB	2811sf two story SFI	2017
New	Approved Basic 17-107156 BP	2015 IRC	Plan 2273C	two story SFR with atta	2017
New	New SFR				2017
New	Approved Basic 17109022BP	2015 IRC	PLAN# 3019	3019sf two stor	2017
New	Approved basic 16-120263 BP	2015 IRC	Plan# 2458	Rambler w/atta	2017

Accessory Dwelling Units

Index # - File Name: 1.0022 - Single Family Dwellings Data\_Snohomish County.pdf

New	Approved basic 16-122036 BP	2015 IRC	Plan# 2418 AB 2015	3-story sfr v	2017
New	Approved basic 16-122036 BP	2015 IRC	Plan# 2418 AB 2015	3-story sfr v	2017
New	Approved basic 16-119082BP	2015 IRC	Plan# 2518 AB 2015	3-story sfr v	2017
New	Approved basic 16-119082BP	2015 IRC	Plan# 2518 AB 2015	3-story sfr v	2017
New	Approved basic 16-119082BP	2015 IRC	Plan# 2518 AB 2015	3-story sfr v	2017
New	New SFR				2017
New	Approved basic 16-113461 BP	2015 IRC	Plan# 3831-B	2-story sfr w/attach	2017
New	Approved basic 16-113463 BP	2015 IRC	Plan# 4723-B	2-story sfr w/attached gar	2017
New	Approved basic 16-113462 BP	2015 IRC	Plan# 4723-A	2-story sfr w/attached	2017
New	Approved Basic 17-115672 BP	2015 IRC	PLAN# 2840	2840sf two story SFR w	2018
New	Approved Basic 17-115637 BP	2015 IRC	PLAN# 2980	2980sf two story SFR with a	2018
New	Approved Basic 17-115672 BP	2015 IRC	PLAN# 2840	2840sf two story SFR w	2018
New	Expiration date extended 120 days per Emergency Ordinance 20-027 EPERMIT Description of W				2018
New	EPERMIT Description of Work: Construct new SFR in Glenmore Div 2				2018
New	New Rambler Glacier Peak Volcanic Hazard Area Disclosure Notice AFN#201808150317				2018
New	New 2-story SFR EPERMIT Description of Work: Construction of a new single family residence c				2018
New	Approved Basic 17-118289BP	2015 IRC	PLAN: Parkland Place	2791sf two story :	2018
New	Approved Basic 17-118289BP	2015 IRC	PLAN: Parkland Place	2791sf two story :	2018
New	Converting crawlspace to finished basement				2018
New	3840 sf 2 story sfr with 944 sf attached garage				2018
New	2 story shop with 2,902 sf garage and 1,111 sf living space - not an ADU				2018
New	New SFR				2018
New	Approved Basic 17-115760 BP	2015 IRC	PLAN# 2834 TRINITY	2834sf two story SFR v	2018
New	Approved Basic 17-115646 BP	2015 IRC	PLAN # 2515 NIXON	2515sf two story SFR w	2018
New	Approved Basic 17-115760 BP	2015 IRC	PLAN# 2834 TRINITY	2834sf two story SFR v	2018
New	Approved Basic 17-115646 BP	2015 IRC	PLAN # 2515 NIXON	2515sf two story SFR w	2018
New	Approved Basic 17-115760 BP	2015 IRC	PLAN# 2834 TRINITY	2834sf two story SFR v	2018
New	Approved Basic 17-115646 BP	2015 IRC	PLAN # 2515 NIXON	2515sf two story SFR w	2018
New	Approved Basic 17-115760 BP	2015 IRC	PLAN# 2834 TRINITY	2834sf two story SFR v	2018
New	Approved Basic 17-106874 BP	2015 IRC	Plan # 2138	2138sf 2 story	2018
New	Approved Basic 17-106874 BP	2015 IRC	Plan # 2138	2138sf 2 story	2018
New	Approved Basic 17-115646 BP	2015 IRC	PLAN # 2515 NIXON	2515sf two story SFR w	2018
New	2 story sfr w/attached garage				2018
New	New 1728 sq ft SFR with 640 sq ft attached garage.				2018
New	New 1490 sq ft dwelling with attached 440 sq ft garage				2018
New	Approved Basic 17-119362 BP	2015 IRC	PLAN: 2175 AB 2015	2175sf three story SFR	2018
New	Approved Basic 17-118650 BP	2015 IRC	PLAN: 2431 AB	2431sf three story SFR	2018
New	Approved Basic 17 114922BP	2015 IRC	2313 -#38	2313 Sq. Ft. SFR with attached garage.	2018
New	Approved basic 16-121949 BP	2015 IRC	Plan# 2578	Rambler w/atta	2018
New	Approved basic 16-118181 BP	2015 IRC	Plan# 3017	2-story sfr w/i	2018
New	Approved Basic 17-109489BP	2015 IRC	PLAN:3664-38#	3664sf daylight ramk	2018
New	Approved Basic 17-118650 BP	2015 IRC	PLAN: 2431 AB	2431sf three story S	2018
New	Approved basic 16-122036 BP	2015 IRC	Plan# 2418 AB 2015	3-story sfr v	2018
New	Approved Basic 17-119362 BP	2015 IRC	PLAN: 2175 AB 2015	2175sf three story SFR	2018
New	Approved basic 16-118443 BP	2015 IRC	Plan# 2301 AB 2015	2-story sf	2018
New	Approved basic 16-122036 BP	2015 IRC	Plan# 2418 AB 2015	3-story sfr v	2018
New	Approved basic 16-122036 BP	2015 IRC	Plan# 2418 AB 2015	3-story sfr v	2018

Accessory Dwelling Units

Index # - File Name: 1.0022 - Single Family Dwellings Data\_Snohomish County.pdf

New	Approved Basic 17-118650 BP	2015 IRC	PLAN: 2431 AB	2431sf three story S	2018
New	Approved Basic 17-119362 BP	2015 IRC	PLAN: 2175 AB 2015	2175sf three story SFR	2018
New	Approved Basic 17-118650 BP	2015 IRC	PLAN: 2431 AB	2431sf three story SF	2018
New	Approved basic 17-105451 BP	2015 IRC	Plan# 2477 (38#)	2 story SF	2018
New	Approved basic 16-122036 BP	2015 IRC	Plan# 2418 AB 2015	3-story sfr v	2018
New	Approved basic 16-118443 BP	2015 IRC	Plan# 2301 AB 2015	2-story sf	2018
New	Approved basic 16-119082BP	2015 IRC	Plan# 2518 AB 2015	3-story sfr v	2018
New	Approved basic 16-118443 BP	2015 IRC	Plan# 2301 AB 2015	2-story sf	2018
New	Approved basic 16-118443 BP	2015 IRC	Plan# 2301 AB 2015	2-story sf	2018
New	Approved basic 16-119082BP	2015 IRC	Plan# 2518 AB 2015	3-story sfr v	2018
New	Approved Basic 17-118650 BP	2015 IRC	PLAN: 2431 AB	2431sf three story SF	2018
New	Approved basic 16-122036 BP	2015 IRC	Plan# 2418 AB 2015	3-story sfr v	2018
New	Approved Basic 17-118650 BP	2015 IRC	PLAN: 2431 AB	2431sf three story SF	2018
New	Approved basic 16-122036 BP	2015 IRC	Plan# 2418 AB 2015	3-story sfr v	2018
New	Approved Basic 17-111587BP	2015 IRC	PLAN:1968	1968sf two story SFR with	2018
New	Approved basic 17119260BP	2015 IRC	Plan 2104	2104 sq. ft. split-level with attached garage.	2018
New	Approved basic 17119260BP	2015 IRC	Plan 2104	2104 sq. ft. split-level with attached garage.	2018
New	Approved Basic 17 109866BP	2015 IRC	plan 2001.	2001 Sq. Ft 2 story home with attached garage	2018
New	Approved Basic 17 109866BP	2015 IRC	plan 2001.	2001 Sq. Ft 2 story home with attached garage	2018
New	Approved Basic 17109460 BP	2015 IRC	PLAN# 1856-2015	1856sf two	2018
New	Approved Basic 17109460 BP	2015 IRC	PLAN# 1856-2015	1856sf two	2018
New	Approved Basic 17109460 BP	2015 IRC	PLAN# 1856-2015	1856sf two	2018
New	Approved Basic 17-111587BP	2015 IRC	PLAN:1968	1968sf two story SFR with	2018
New	Approved Basic 17-111587BP	2015 IRC	PLAN:1968	1968sf two story SFR with	2018
New	Approved Basic 17 109866BP	2015 IRC	plan 2001.	2001 Sq. Ft 2 story home with attached garage	2018
New	Approved Basic 17 109866BP	2015 IRC	plan 2001.	2001 Sq. Ft 2 story home with attached garage	2018
New	Approved basic 17119260BP	2015 IRC	Plan 2104	2104 sq. ft. split-level with attached garage.	2018
New	Approved Basic 17119484BP	2015 IRC	PLAN: CV2DUP-A	3731SF three story dupl	2018
New	Approved Basic 17-119486BP	2015 IRC	PLAN: CV2DUP-B	3731SF three story Duplex	2018
New	Approved Basic 17-119492BP	2015 IRC	PLAN: CV2DUP-C	3731SF Three story Dup	2018
New	Approved Basic 17119484BP	2015 IRC	PLAN: CV2DUP-A	3731SF three story dupl	2018
New	Approved Basic 17-119493BP	2015 IRC	PLAN: CV2DUP-D	3731sqft three story Duplex	2018
New	Approved basic 17-100203 BP	2015 IRC	Plan# 2254 (25#)	Rambler v	2018
New	New Duplex				2018
New	Double Wide	*** Warning: See Comment Tab for any further work. ***			2018
New	New SFR				2018
New	2218 s.f. rambler w/attached garage				2018
New	Expiration date extended 120 days per Emergency Ordinance 20-027 Rambler style home:	2829			2018
New	Approved Basic 18 100909BP	2015 irc	3862A	3800 Sq ft tr-ilevel with attached garage	2018
New	Approved Basic 18 100938BP	2015 irc	3862B	3800 Sq ft tr-ilevel with attached garage	2018
New	Approved Basic 18111871BP	2015 IRC	3183B	3183 square ft 2 story with attached garage	2018
New	Approved Basic 18111870BP	2015 IRC	3183A	3183 square ft 2 story with attached garage	2018
New	Approved Basic 17-108108BP	2015 IRC	PLAN# 3395A	2 Story SFR w/E	2018
New	Approved Basic 18 100909BP	2015 irc	3862A	3800 Sq ft tr-ilevel with attached garage	2018
New	Approved basic 16-121135 BP	2015 IRC	Plan# 2825A	2-story sfr w/attach	2018
New	Approved basic 17-100304 BP	2015 IRC	Plan# 3222B	2-story sfr w/finishe	2018

Accessory Dwelling Units

Index # - File Name: 1.0022 - Single Family Dwellings Data\_Snohomish County.pdf

New	Expiration date extended 120 days per Emergency Ordinance 20-027	Two story SFR with attached garage	2018
New	EPERMIT Description of Work: Lot 31 Glenmore - construct a new SFR		2018
New	New 2498 sq ft SFR with 1620 sq ft of attached garage		2018
New	EPERMIT Description of Work: Glenmore Lot 33 - construct new SFR		2018
New	EPERMIT Description of Work: Construct a new SFR		2018
New	EPERMIT Description of Work: Construct a new SFR		2018
New	EPERMIT Description of Work: Construct New SFR		2018
New	EPERMIT Description of Work: Construct New SFR		2018
New	EPERMIT Description of Work: Lot 38 Glenmore - construct new SFR		2018
New	New 2 story 4079 sq ft SFR with 817 sq ft of attached garage.		2018
New	New 2 story 3246 sq ft SFR with 653 sq ft of attached garage		2018
New	New 2 story residence of 2805 sq ft, 660 sq ft of attached garage, and 404 sq ft covered porch.		2018
New	Approved basic 16-121949 BP	2015 IRC Plan# 2578 Rambler w/attached garage	2018
New	Approved Basic 17109022BP	2015 IRC PLAN# 3019 3019sf two story SFR	2018
New	Approved basic 16-120263 BP	2015 IRC Plan# 2458 Rambler w/attached garage	2018
New	Approved basic 16-118182 BP	2015 IRC Plan# 2972 2-story sfr w/attached garage	2018
New	Approved basic 16-121949 BP	2015 IRC Plan# 2578 Rambler w/attached garage	2018
New	Approved Basic 17 114922BP	2015 IRC 2313 -#38 2313 Sq. Ft. SFR with attached garage.	2018
New	Approved basic 16-118182 BP	2015 IRC Plan# 2972 2-story sfr w/attached garage	2018
New	Approved basic 16-120263 BP	2015 IRC Plan# 2458 Rambler w/attached garage	2018
New	Approved Basic 17-107067 BP	2015 IRC 2 story sfr with attached garage	2018
New	Approved Basic 17-107067 BP	2015 IRC Plan 2101 A/B 2 story sfr with attached garage	2018
New	Approved basic 16-114982 BP	2015 IRC Plan# 3072 2-story sfr w/attached garage	2018
New	Approved basic 16-114982 BP	2015 IRC Plan# 3072 2-story sfr w/attached garage	2018
New	Approved basic 16-113328 BP	2015 IRC Plan# Trafton C 2-story sfr w/attached garage	2018
New	Approved basic 16-113033 BP	2015 IRC Plan# Rainier D 2-story sfr w/attached garage	2018
New	Approved basic 16-113867 BP	2015 IRC Plan# Newhalem D 2-story sfr w/attached garage	2018
New	Approved basic 16-116037 BP	2015 IRC Plan# Hazelwood C 2-story sfr w/attached garage	2018
New	Approved basic 16-113328 BP	2015 IRC Plan# Trafton C 2-story sfr w/attached garage	2018
New	Approved basic 16-108597 BP	2015 IRC Plan# Dayton C 2-story sfr w/attached garage	2018
New	Approved basic 17-101561 BP	2015 IRC Plan# Baker C/D Daylight 2story sfr w/attached garage	2018
New	Approved basic 16-112018 BP	2015 IRC Plan# Trafton C Daylight 2-story sfr w/attached garage	2018
New	Approved basic 17-100648 BP	2015 IRC Plan# Armstrong Daylight C/D 2story sfr w/attached garage	2018
New	Approved basic 16-121324 BP	2015 IRC Plan# Newhalem C Daylight 2-story sfr w/attached garage	2018
New	Approved basic 16-112022 BP	2015 IRC Plan# Trafton D Daylight 2-story sfr w/attached garage	2018
New	Approved basic 17-100648 BP	2015 IRC Plan# Armstrong Daylight C/D 2story sfr w/attached garage	2018
New	Approved basic 16-121325 BP	2015 IRC Plan# Newhalem D Daylight 2-story sfr w/attached garage	2018
New	Approved basic 16-112018 BP	2015 IRC Plan# Trafton C Daylight 2-story sfr w/attached garage	2018
New	Approved basic 17-101561 BP	2015 IRC Plan# Baker C/D Daylight 2story sfr w/attached garage	2018
New	Approved Basic 16-112153 BP	2015 IRC Plan# Baker C 2-story sfr w/attached garage	2018
New	Approved basic 16-108597 BP	2015 IRC Plan# Dayton C 2-story sfr w/attached garage	2018
New	Approved basic 16-113330 BP	2015 IRC Plan# Trafton D 2-story sfr w/attached garage	2018
New	Approved basic 16-109158 BP	2015 IRC Plan# Kimball C 2-story sfr w/attached garage	2018
New	Approved Basic 16-113032 BP	2015 IRC Plan# Rainier C 2-story sfr w/attached garage	2018
New	Approved Basic 16-112153 BP	2015 IRC Plan# Baker C 2-story sfr w/attached garage	2018
New	Rambler sfr w/ attached garage		2018
New	Approved basic 17-101561 BP	2015 IRC Plan# Baker C/D Daylight 2story sfr w/attached garage	2018

Accessory Dwelling Units

Index # - File Name: 1.0022 - Single Family Dwellings Data\_Snohomish County.pdf

New	Approved basic 16-121324 BP	2015 IRC	Plan# Newhalem C Daylight	2-stc	2018
New	Approved basic 16-112022 BP	2015 IRC	Plan# Trafton D Daylight	2-stor	2018
New	Approved basic 16-116037 BP	2015 IRC	Plan# Hazelwood C	2-story sfr w/a	2018
New	Approved Basic 17-111208 BP	2015 IRC	PLAN: Dayton II D	2084sf two story	2018
New	Approved basic 16-113865 BP	2015 IRC	Plan # Newhalem C	2-story sfr w/atta	2018
New	Approved basic 16-112022 BP	2015 IRC	Plan# Trafton D Daylight	2-stor	2018
New	Approved basic 17-100648 BP	2015 IRC	Plan# Armstrong Daylight C/D	2story sfr	2018
New	Approved basic 17-100648 BP	2015 IRC	Plan# Armstrong Daylight C/D	2story sfr	2018
New	Approved basic 16-113867 BP	2015 IRC	Plan# Newhalem D	2-story sfr w/attache	2018
New	Approved basic 16-113033 BP	2015 IRC	Plan# Rainier D	2-story sfr w/attached g	2018
New	Approved basic 16-109161 BP	2015 IRC	Plan# Kimball D	2-story sfr w/attached	2018
New	Approved basic 16-108597 BP	2015 IRC	Plan# Dayton C	2-story sfr w/attached	2018
New	Approved Basic 17-111208 BP	2015 IRC	PLAN: Dayton II D	2084sf two story	2018
New	Approved basic 16-116039 BP	2015 IRC	Plan# Hazelwood D	2-story sfr w/a	2018
New	Approved Basic 16-113032 BP	2015 IRC	Plan# Rainier C	2-story sfr w/attached g	2018
New	Approved basic 16-109158 BP	2015 IRC	Plan# Kimball C	2-story sfr w/attached	2018
New	Approved basic 16-108597 BP	2015 IRC	Plan# Dayton C	2-story sfr w/attached	2018
New	Approved basic 16-113867 BP	2015 IRC	Plan# Newhalem D	2-story sfr w/attache	2018
New	Approved basic 16-109161 BP	2015 IRC	Plan# Kimball D	2-story sfr w/attached	2018
New	Approved basic 16-116037 BP	2015 IRC	Plan# Hazelwood C	2-story sfr w/a	2018
New	Approved basic 16-113033 BP	2015 IRC	Plan# Rainier D	2-story sfr w/attached g	2018
New	Approved basic 16-109158 BP	2015 IRC	Plan# Kimball C	2-story sfr w/attached	2018
New	Approved Basic 17-111208 BP	2015 IRC	PLAN: Dayton II D	2084sf two story	2018
New	Approved basic 16-116039 BP	2015 IRC	Plan# Hazelwood D	2-story sfr w/a	2018
New	Approved basic 16-113330 BP	2015 IRC	Plan# Trafton D	2-story sfr w/attached	2018
New	Approved basic 16-109158 BP	2015 IRC	Plan# Kimball C	2-story sfr w/attached	2018
New	Approved basic 16-113033 BP	2015 IRC	Plan# Rainier D	2-story sfr w/attached g	2018
New	Approved basic 16-116037 BP	2015 IRC	Plan# Hazelwood C	2-story sfr w/a	2018
New	Approved basic 16-108597 BP	2015 IRC	Plan# Dayton C	2-story sfr w/attached	2018
New	Approved basic 16-113865 BP	2015 IRC	Plan # Newhalem C	2-story sfr w/atta	2018
New	Approved basic 16-109161 BP	2015 IRC	Plan# Kimball D	2-story sfr w/attached	2018
New	Approved Basic 16-113032 BP	2015 IRC	Plan# Rainier C	2-story sfr w/attached g	2018
New	Approved basic 16-116039 BP	2015 IRC	Plan# Hazelwood D	2-story sfr w/a	2018
New	Approved basic 16-109158 BP	2015 IRC	Plan# Kimball C	2-story sfr w/attached	2018
New	Approved basic 16-113330 BP	2015 IRC	Plan# Trafton D	2-story sfr w/attached	2018
New	Approved Basic 17-111208 BP	2015 IRC	PLAN: Dayton II D	2084sf two story	2018
New	Approved basic 16-113865 BP	2015 IRC	Plan # Newhalem C	2-story sfr w/atta	2018
New	Approved basic 16-109161 BP	2015 IRC	Plan# Kimball D	2-story sfr w/attached	2018
New	Approved basic 16-116037 BP	2015 IRC	Plan# Hazelwood C	2-story sfr w/a	2018
New	Approved Basic 16-113032 BP	2015 IRC	Plan# Rainier C	2-story sfr w/attached g	2018
New	Approved basic 16-109158 BP	2015 IRC	Plan# Kimball C	2-story sfr w/attached	2018
New	Approved Basic 17115379BP	2015IRC 1866	2 story SFR with attached garage.		2018
New	Approved Basic 17115379BP	2015IRC 1866	2 story SFR with attached garage.		2018
New	Approved Basic 17 114855BP	2015 IRC	Plan 2353AB	2353 Sq Ft Single Family Re:	2018
New	Approved Basic 17115379BP	2015IRC 1866	2 story SFR with attached garage.		2018
New	Approved Basic 17115379BP	2015IRC 1866	2 story SFR with attached garage.		2018
New	Approved basic 17-107308BP	2015 IRC	Plan 2515 A/B	two story SFR wit	2018

Accessory Dwelling Units

Index # - File Name: 1.0022 - Single Family Dwellings Data\_Snohomish County.pdf

New	Approved	Basic 17-107158 BP	2015 IRC	Plan 2273D	2 story SFR with at	2018
New	Approved	Basic 17-112393 BP	2015 IRC	PLAN 2811 AB	2811sf two story SFI	2018
New	Approved	Basic 17 114855BP	2015 IRC	Plan 2353AB	2353 Sq Ft Single Family Re:	2018
New	Approved	basic 17-107308BP	2015 IRC	Plan 2515 A/B	two story SFR wit	2018
New	Approved	Basic 17-107156 BP	2015 IRC	Plan 2273C	two story SFR with atta	2018
New	Approved	Basic 17-112393 BP	2015 IRC	PLAN 2811 AB	2811sf two story SFI	2018
New	Approved	Basic 17-112393 BP	2015 IRC	PLAN 2811 AB	2811sf two story SFI	2018
New	Approved	basic 17-107308BP	2015 IRC	Plan 2515 A/B	two story SFR wit	2018
New	Approved	Basic 17-107158 BP	2015 IRC	Plan 2273D	2 story SFR with at	2018
New	Approved	Basic 17 114855BP	2015 IRC	Plan 2353AB	2353 Sq Ft Single Family Re:	2018
New	Approved	Basic 17-107156 BP	2015 IRC	Plan 2273C	two story SFR with atta	2018
New	Approved	basic 17-107308BP	2015 IRC	Plan 2515 A/B	two story SFR wit	2018
New	Approved	Basic 17 114855BP	2015 IRC	Plan 2353AB	2353 Sq Ft Single Family Re:	2018
New	Approved	Basic 17-107158 BP	2015 IRC	Plan 2273D	2 story SFR with at	2018
New	Approved	Basic 17 114855BP	2015 IRC	Plan 2353AB	2353 Sq Ft Single Family Re:	2018
New	Approved	Basic 17-107067 BP	2015 IRC	Plan 2101 A/B	2 story sfr with attach	2018
New	Approved	Basic 17-107156 BP	2015 IRC	Plan 2273C	two story SFR with atta	2018
New		2635 square foot SFR with 1272 square foot finished basement and attached Garage **30 DAY I				2018
New		***8/8/19 cst One time 30 day extension granted*** New 4,616 SF 3 story (including unfinishe				2018
New	Approved	basic 16-114079 BP	2015 IRC	Plan# 2766	2766 s.f. rambler w/att	2018
New	Approved	Basic 17109022BP	2015 IRC	PLAN# 3019	3019sf two stor	2018
New		2480 square foot SFR with 2230 square foot unfinished basement & attached Garage				2018
New	Approved	Basic 18-122798BP	2015 IRC	PLAN: 3284 30# SL	3284sf two story SFR with at	2018
New	Approved	Basic 17-118293 BP	2015 IRC	PLAN: 2747	2747 sf two story single family	2018
New	Approved	Basic 17-118293 BP	2015 IRC	PLAN: 2747	2747 sf two story single family	2018
New		2 story sfr w/attached garage				2018
New	Approved	Basic 17-118293 BP	2015 IRC	PLAN: 2747	2747 sf two story single family	2018
New	Approved	Basic 17-118293 BP	2015 IRC	PLAN: 2747	2747 sf two story single family	2018
New		Two story SFR with attached Garage				2018
New		Water Use Covenant AFN: 201802280510 New SFR				2018
New		1280 s.f. rambler w/attached garage				2018
New		1280 s.f. rambler w/attached garage				2018
New		New 5361 sq ft house with attached 960 sq ft garage. **30 day extension given SCDCGB** ***\				2018
New		2591 s.f. rambler w/attached garage AFN: 201807180196, Declaration of Easement for Utilities				2018
New	Approved	basic 16-114982 BP	2015 IRC	Plan# 3072	2-story sfr w/attached }	2018
New		2591 s.f. rambler w/attached garage				2018
New	Approved	basic 16-114982 BP	2015 IRC	Plan# 3072	2-story sfr w/attached }	2018
New	Approved	Basic 18-101302BP	2015 IRC	PLAN#3350	3350SF single family re	2018
New	Approved	Basic 18-120712 BP	2015 IRC	2212	3 Bedroom Rambler with 3 car garage	2018
New	Approved	basic 16-114079 BP	2015 IRC	Plan# 2766	2766 s.f. rambler w/att	2018
New	Approved	basic 16-114079 BP	2015 IRC	Plan# 2766	2766 s.f. rambler w/att	2018
New	Approved	Basic 18-1207130 BP	2015 IRC	3044	3 Bedroom SFR with 3 car garage Plan to be u	2018
New	Approved	basic 16-114079 BP	2015 IRC	Plan# 2766	2766 s.f. rambler w/att	2018
New	Approved	basic 16-120708 BP	2015 IRC	Plan# 3484	2-story sfr w/attache	2018
New	Approved	basic 16-120708 BP	2015 IRC	Plan# 3484	2-story sfr w/attache	2018
New	Approved	Basic 18-123133BP	2015 IRC	PLAN: 3023 30# Snow load	3023 two story !	2018
New	Approved	Basic 18-122798BP	2015 IRC	PLAN: 3284 30# SL	3284sf two story SFR with a	2018



Accessory Dwelling Units

Index # - File Name: 1.0022 - Single Family Dwellings Data\_Snohomish County.pdf

New	Approved Basic 18-122823BP	2015 IRC	PLAN: 3428 30# SL	3428sf three story SFR with	2018
New	Approved Basic 18100014BP	2015 IRC	3634	3634 sq ft 2 story with attached garage.	2018
New	Approved Basic 18100014BP	2015 IRC	3634	3634 sq. ft. 2 story with attached	2018
New	Approved Basic 17110802BP	2015 IRC	PLAN: 3428-2550 DL	3428sf three story	2018
New	Approved Basic 17 119907 BP	2015 IRC	3286	2 story SFR with attached garage and covered	2018
New	Approved Basic 17-106124 BP	2015 IRC	Plan 3271	two story SFR with attached 3-car ga	2018
New	Approved Basic 18-120712 BP	2015 IRC	2212	3 Bedroom Rambler with 3 car garage	2018
New	Approved Basic 18-1207130 BP	2015 IRC	3044	3 Bedroom SFR with 3 car garage Plan to be u	2018
New	New SFR				2018
New	Two story SFR with attached Garage				2018
New	Glacier Peak Volcanic Hazard Area Disclosure Notice recording # 201801180428			2000 27 X 30	2018
New	Expiration date extended 120 days per Emergency Ordinance 20-027			New 2-story 3365 sq ft hou	2018
New	New 50 X 50 SFR				2018
New	New 50 X 50 SFR				2018
New	Approved Basic 17 110756BP	2015 IRC	PLAN: 1833 New	1833sf three sto	2018
New	Expiration date extended 120 days per Emergency Ordinance 20-027			New SFR CASP AFN 2018(	2018
New	Expiration date extended 120 days per Emergency Ordinance 20-027			New two story SFR with at	2018
New	New SFR				2018
New	Approved basic 17-100648 BP	2015 IRC	Plan# Armstrong Daylight C/D	2story sfr	2018
New	Approved basic 16-121324 BP	2015 IRC	Plan# Newhalem C Daylight	2-stc	2018
New	Approved basic 16-112022 BP	2015 IRC	Plan# Trafton D Daylight	2-stor	2018
New	Approved basic 17-100648 BP	2015 IRC	Plan# Armstrong Daylight C/D	2story sfr	2018
New	Approved basic 16-112018 BP	2015 IRC	Plan# Trafton C Daylight	2-story w/finishe	2018
New	Approved basic 17-100648 BP	2015 IRC	Plan# Armstrong Daylight C/D	2story sfr	2018
New	Approved basic 16-114982 BP	2015 IRC	Plan# 3072	2-story sfr w/attached }	2018
New	New SFR Approved RSP 6/29/18			16-114982 BP	2018
New	Approved basic 16-114982 BP	2015 IRC	Plan# 3072	2-story sfr w/attached }	2018
New	Approved Basic: 17-105992 BP	2015 IRC	Plan: Whatcom C/ D	2532 sf 2 story w/finishe	2018
New	Approved Basic 17-109820BP	2015 IRC	PLAN: Tyee C/D	2620sf 3 story SFR v	2018
New	Approved Basic: 17-105992 BP	2015 IRC	Plan: Whatcom C/ D	2532 sf 2 story w/fin	2018
New	Approved Basic 17-106270 BP	2015 IRC	Plan Kokanee C D	2 story sfr with daylight basen	2018
New	Approved Basic: 17-105992 BP	2015 IRC	Plan: Whatcom C/ D	2532 sf 2 story w/finishe	2018
New	Approved Basic 17-111130 BP	2015 IRC	PLAN: Palmer II C/D	2451sf three st	2018
New	Approved basic 16-115149 BP	2015 IRC	Plan# Windom C/D	2-story sfr w/finish	2018
New	Approved basic 16-115979 BP	2015 IRC	Plan# Amherst C/D	2-story sfr w/ç	2018
New	Approved Basic: 17-105992 BP	2015 IRC	Plan: Whatcom C/ D	2532 sf 2 story w/fin	2018
New	Approved Basic 17-111130 BP	2015 IRC	PLAN: Palmer II C/D	2451sf three st	2018
New	Approved basic 17-100312 BP	2015 IRC	Plan# 2501A	2-story sfr w/attache	2018
New	Approved basic 16-121137 BP	2015 IRC	Plan# 2825C	2-story sfr w/attac	2018
New	Approved basic 17-100313 BP	2015 IRC	Plan# 2501B	2-story sfr w/attache	2018
New	Approved basic 16-111597 BP	2015 IRC	Plan# 2494A	2-story w/attache	2018
New	Approved basic 17-100313 BP	2015 IRC	Plan# 2501B	2-story sfr w/attache	2018
New	Approved basic 16-111597 BP	2015 IRC	Plan# 2494A	2-story w/attache	2018
New	Approved basic 17-100312 BP	2015 IRC	Plan# 2501A	2-story sfr w/attache	2018
New	Approved basic 17-100312 BP	2015 IRC	Plan# 2501A	2-story sfr w/attache	2018
New	Approved basic 17-100313 BP	2015 IRC	Plan# 2501B	2-story sfr w/attache	2018
New	Approved basic 17-100313 BP	2015 IRC	Plan# 2501B	2-story sfr w/attache	2018

Accessory Dwelling Units

Index # - File Name: 1.0022 - Single Family Dwellings Data\_Snohomish County.pdf

New	Approved basic 16-120910 BP	2015 IRC	Plan#1836A	2-story sfr w/attach	2018
New	Approved Basic 17-108109 BP	2015 IRC	PLAN#: 3395B	3395SF two story SF	2018
New	2 story sfr w/attached garage				2018
New	Approved Basic 17-108108BP	2015 IRC	PLAN# 3395A	2 Story SFR w/E	2018
New	2 story sfr w/attached garage				2018
New	2 story sfr w/attached garage				2018
New	2 story sfr w/attached garage				2018
New	2 story sfr w/attached garage				2018
New	2 story sfr w/attached garage				2018
New	2 story sfr w/attached garage				2018
New	2 story sfr w/attached garage				2018
New	Water Use Covenant AFN: 201807240425			New two story single family home	2018
New	Approved basic 16-111597 BP	2015 IRC	Plan# 2494A	2-story w/attached	2018
New	Approved basic 17-100312 BP	2015 IRC	Plan# 2501A	2-story sfr w/attache	2018
New	Approved basic 17-100313 BP	2015 IRC	Plan# 2501B	2-story sfr w/attache	2018
New	Approved Basic 17-108108BP	2015 IRC	PLAN# 3395A	2 Story SFR w/E	2018
New	Approved Basic 18-101614 BP	2015 IRC	PLAN: 2190A	2190sf two story SFF	2018
New	Approved basic 17-100313 BP	2015 IRC	Plan# 2501B	2-story sfr w/attache	2018
New	Approved basic 16-111597 BP	2015 IRC	Plan# 2494A	2-story w/attache	2018
New	Approved Basic 18-101613 BP	2015 IRC	PLAN: 2190B	2190sf two story SFR with	2018
New	Approved Basic 17-108111BP	2015 IRC	Plan #3471	3471sf three st	2018
New	Approved basic 17-100313 BP	2015 IRC	Plan# 2501B	2-story sfr w/attache	2018
New	Approved Basic 18-101614 BP	2015 IRC	PLAN: 2190A	2190sf two story SFF	2018
New	Approved basic 17-100313 BP	2015 IRC	Plan# 2501B	2-story sfr w/attache	2018
New	Approved basic 16-111597 BP	2015 IRC	Plan# 2494A	2-story w/attache	2018
New	Approved basic 17-100312 BP	2015 IRC	Plan# 2501A	2-story sfr w/attache	2018
New	Approved Basic 17-108111BP	2015 IRC	Plan #3471	3471sf three st	2018
New	Approved basic 16-111598 BP	2015 IRC	Plan# 2494B	2-story w/attached	2018
New	Approved basic 17-100313 BP	2015 IRC	Plan# 2501B	2-story sfr w/attache	2018
New	Approved basic 16-121135 BP	2015 IRC	Plan# 2825A	2-story sfr w/attache	2018
New	Approved basic 17-100312 BP	2015 IRC	Plan# 2501A	2-story sfr w/attache	2018
New	Approved basic 16-111597 BP	2015 IRC	Plan# 2494A	2-story w/attache	2018
New	Approved basic 17-100203 BP	2015 IRC	Plan# 2254 (25#)	Rambler v	2018
New	Approved Basic 17 119962 BP	2015 IRC	1825	2 story duplex with attached	2018
New	New 2673 sq ft duplex - 1336 per side - with 380sq ft attached garages for each unit.				2018
New	2 story sfr w/attached garage				2018
New	2 story sfr w/attached garage				2018
New	Approved Basic 17-108805BP	2015 IRC	PLAN# Harlequin 1784	1784sf 2 st	2018
New	Approved Basic 17-108805BP	2015 IRC	PLAN# Harlequin 1784	1784sf 2 st	2018
New	Expiration date extended 120 days per Emergency Ordinance 20-027 EPERMIT Description of W				2018
New	Expiration date extended 120 days per Emergency Ordinance 20-027 EPERMIT Description of W				2018
New	Expiration date extended 120 days per Emergency Ordinance 20-027 Two story SFR				2018
New	Expiration date extended 120 days per Emergency Ordinance 20-027 EPERMIT Description of W				2018
New	New SFR				2018
New	Single story 3202 sf SFR with 809 sf attached garage				2018

Accessory Dwelling Units

Index # - File Name: 1.0022 - Single Family Dwellings Data\_Snohomish County.pdf

New	3 story sfr w/attached garage				2018
New	3 story sfr w/attached garage				2018
New	3 story sfr w/attached garage				2018
New	3 story sfr w/attached garage				2018
New	2 story sfr w/ attached garage				2018
New	Approved Basic 17-111515 BP	2015 IRC	PLAN: 2972-38#	2972sf two story SFR	2018
New	Approved Basic 17-113335BP	2015 IRC		2664sf two story SFR with finished baser	2018
New	Approved Basic 17 110700BP	2015 IRC	Plan 3049-38#	3049Sq Ft Single Family Residence w	2018
New	Approved Basic 17-109489BP	2015 IRC	PLAN:3664-38#	3664sf daylight ram	2018
New	Approved Basic 17-113335BP	2015 IRC		2664sf two story SFR with finished basem	2018
New	Approved Basic 17-109489BP	2015 IRC	PLAN:3664-38#	3664sf daylight ram	2018
New	Approved Basic 17 114859	2015 IRC		2578 Sq. FT. SFR with attached garage.	2018
New	Approved Basic 17-113335BP	2015 IRC		2664sf two story SFR with finished baser	2018
New	Approved Basic 17-109489BP	2015 IRC	PLAN:3664-38#	3664sf daylight ram	2018
New	Approved Basic 17-106927 BP	2015 IRC	Plan# 3019	3019sf two story SFR	2018
New	Approved Basic 17 114919 BP	205 IRC		2578 SQ Ft. SFR with attached garage.	2018
New	Single story 2256 sf SFR with 539 sf attached garage				2018
New	Approved basic 16-113276 BP	2015 IRC	Plan# Chelan II C	2-story sfr w/attached	2018
New	Approved basic 16-113330 BP	2015 IRC	Plan# Trafton D	2-story sfr w/attached {	2018
New	Approved basic 16-109158 BP	2015 IRC	Plan# Kimball C	2-story sfr w/attached	2018
New	Approved basic 16-113865 BP	2015 IRC	Plan # Newhalem C	2-story sfr w/atta	2018
New	Approved basic 16-113033 BP	2015 IRC	Plan# Rainier D	2-story sfr w/attached g	2018
New	Approved basic 16-113330 BP	2015 IRC	Plan# Trafton D	2-story sfr w/attached {	2018
New	Approved basic 16-109161 BP	2015 IRC	Plan# Kimball D	2-story sfr w/attached	2018
New	Approved basic 16-113867 BP	2015 IRC	Plan# Newhalem D	2-story sfr w/attache	2018
New	Approved Basic 16-113032 BP	2015 IRC	Plan# Rainier C	2-story sfr w/attached g	2018
New	Approved Basic 18 111827BP	2015 irc	The Pratt 2309	SF 2 story with attached garage.	2018
New	Approved Basic 18 111827BP	2015 irc	The Pratt 2309	SF 2 story with attached garage.	2018
New	Approved Basic 18 111809BP	2015 irc	The Madras 2379	SF 2 story with attached gara	2018
New	Approved Basic 18 111827BP	2015 irc	The Pratt 2309	SF 2 story with attached garage.	2018
New	Approved Basic 18 111827BP	2015 IRC	The Pratt 2309	SF 2 story with attached garage	2018
New	Approved Basic 18 111809BP	2015 irc	The Madras 2379	SF 2 story with attached gara	2018
New	Approved Basic 18 111827BP	2015 irc	The Pratt 2309	SF 2 story with attached garage.	2018
New	Approved Basic 18 111827BP	2015 irc	The Pratt 2309	SF 2 story with attached garage.	2018
New	Approved Basic 18 111809BP	2015 irc	The Madras 2379	SF 2 story with attached gara	2018
New	Approved Basic 18 111827BP	2015 irc	The Pratt 2309	SF 2 story with attached garage.	2018
New	Approved Basic 18 111809BP	2015 irc	The Madras 2379	SF 2 story with attached gara	2018
New	Approved Basic 18 111827BP	2015 irc	The Pratt 2309	SF 2 story with attached garage.	2018
New	New duplex				2018
New	Expiration date extended 120 days per Emergency Ordinance 20-027			New 30 day extension due	2018
New	Expiration date extended 120 days per Emergency Ordinance 20-027			EPERMIT Description of W	2018
New	Expiration date extended 120 days per Emergency Ordinance 20-027			EPERMIT Description of W	2018
New	Expiration date extended 120 days per Emergency Ordinance 20-027			EPERMIT Description of W	2018
New	Expiration date extended 120 days per Emergency Ordinance 20-027			EPERMIT Description of W	2018
New	Expiration date extended 120 days per Emergency Ordinance 20-027			EPERMIT Description of W	2018
New	Expiration date extended 120 days per Emergency Ordinance 20-027			EPERMIT Description of Work: Construction of new SFR	2018

Accessory Dwelling Units

Index # - File Name: 1.0022 - Single Family Dwellings Data\_Snohomish County.pdf

New	Approved basic 16-118185 BP	2015 IRC	Plan# 2537	2-story sfr w/	2018
New	Replacing SFR with 2017 26 X 48 Double-wide MH				2018
New	Approved Basic 18-113462BP	2015 IRC	PLAN: 2774A	2774sf three story SFR with	2018
New	Approved Basic 18-113462BP	2015 IRC	PLAN: 2774A	2774sf three story SFR with	2018
New	Approved Basic 18-113462BP	2015 IRC	PLAN: 2774A	2774sf three story SFR with	2018
New	Approved Basic 18-113462BP	2015 IRC	PLAN: 2774A	2774sf three story SFR with	2018
New	Approved Basic 18-113462BP	2015 IRC	PLAN: 2774A	2774sf three story SFR with	2018
New	Approved Basic 18-113462BP	2015 IRC	PLAN: 2774A	2774sf three story SFR with	2018
New	Approved Basic 18-113462BP	2015 IRC	PLAN: 2774A	2774sf three story SFR with	2018
New	Approved Basic 18-113462BP	2015 IRC	PLAN: 2774A	2774sf three story SFR with	2018
New	Approved Basic 18-113462BP	2015 IRC	PLAN: 2774A	2774sf three story SFR with	2018
New	Approved Basic 18-113462BP	2015 IRC	PLAN: 2774A	2774sf three story SFR with	2018
New	Two story SFR with attached Garage				2018
New	Expiration date extended 120 days per Emergency Ordinance 20-027 2 story sfr w/attached gara				2018
New	Expiration date extended 120 days per Emergency Ordinance 20-027 2 story sfr w/attached gara				2018
New	New SFR				2018
New	Approved Basic 18-115911BP	2015IRC	PLAN 2853MHI	2853sf two story SFR with att	2018
New	Approved Basic 18-115911BP	2015IRC	PLAN 2853MHI	2853sf two story SFR with att	2018
New	2 story sfr w/attached garage				2018
New	2 story sfr w/attached garage				2018
New	Approved Basic 18113174BP	2015 IRC	2809 sq. ft. 2 story with attached garage conditions		2018
New	Approved Basic 17 119962 BP	2015 IRC	1825 2 story duplex with attached garages. conditi		2018
New	Approved basic 18113132BP	2015 IRC	3112 Sq FT multi level sfr conditions revised 01-29-20		2018
New	Approved Basic 18113210BP	2015 IRC	456E XXXX 2 story with attached garage conditic		2018
New	Approved Basic 18113184BP	2015 IRC	2 story with attached garage conditions revised 01-29		2018
New	Approved Basic 18113200BP	2015 IRC	split level SFR with attached garage conditions revised		2018
New	Approved Basic 18113132BP	2015 IRC	3112 Sq FT multi level sfr		2018
New	Expiration date extended 120 days per Emergency Ordinance 20-027 AFN: 201804050049		2498		2018
New	Approved Basic 18-116257 BP	2015 IRC	PLAN: 2323 - 50 Lb Snowload	2323	2018
New	Approved Basic 17-112703BP	2015 IRC	PLAN: 2323	2323sf two story SFR	2018
New	Approved Basic 17-104257 BP	2015 IRC	Plan# 3653	2-story SFR (3,653 SF) w/at	2018
New	Approved Basic 17-104257 BP	2015 IRC	Plan# 3653	2-story SFR (3,653 SF) w/at	2018
New	Approved Basic 17-104257 BP	2015 IRC	Plan# 3653	2-story SFR (3,653 SF) w/at	2018
New	2018 15 X 60 Single-wide Mobile Home		AFN# 201805300092		2018
New	New SFR				2018
New	30 day extension given 12/16/2019 esp Notice of Right To Practice Forestry		AFN: 201805240321		2018
New	New SFR above garage				2018
New	Approved Basic 18-117490BP	2015 IRC	1858	3 story 3 bedroom SFR with attached g	2018
New	Approved Basic 18-117385BP	2015 IRC	PLAN: 1742	1742sf Three Story SFR with	2018
New	Approved Basic 18-118212BP	2015 IRC	Plan: 1644	1644sf three story SFR w	2018
New	Approved Basic 18-117490BP	2015 IRC	1858	3 story 3 bedroom SFR with attached g	2018
New	Approved Basic 18-117490BP	2015 IRC	1858	3 story 3 bedroom SFR with attached	2018
New	Approved Basic 18-117385BP	2015 IRC	PLAN: 1742	1742sf Three Story SFR with	2018
New	Approved Basic 18-117385BP	2015 IRC	PLAN: 1742	1742sf Three Story SFR with	2018
New	Approved Basic 18-117490BP	2015 IRC	1858	3 story 3 bedroom SFR with attached g	2018
New	Approved 18-117682BP	2015 IRC	PLAN: 2019	2019sf three story SFR with attachec	2018
New	Approved Basic 18-118212BP	2015 IRC	Plan: 1644	1644sf three story SFR w	2018

Accessory Dwelling Units

Index # - File Name: 1.0022 - Single Family Dwellings Data\_Snohomish County.pdf

New	EPERMIT Description of Work: Lot specific floor plan for Andoria project				2018
New	Approved Basic 18-117385BP	2015 IRC	PLAN: 1742	1742sf Three Story SFR with	2018
New	Approved Basic 18-117490BP	2015 IRC	1858	3 story 3 bedroom SFR with attached	2018
New	Approved Basic 18-117385BP	2015 IRC	PLAN: 1742	1742sf Three Story SFR with	2018
New	Approved Basic 18-117490BP	2015 IRC	1858	3 story 3 bedroom SFR with attached	2018
New	Approved Basic 18-117385BP	2015 IRC	PLAN: 1742	1742sf Three Story SFR with	2018
New	Approved Basic 18-117490BP	2015 IRC	1858	3 story 3 bedroom SFR with attached	2018
New	Approved Basic 18-117368BP	2015 IRC	PLAN: 1516	1516sf Three Story SF	2018
New	Approved 18-117682BP	2015 IRC	PLAN: 2019	2019sf three story SFR with attached	2018
New	Approved Basic 18-118212BP	2015 IRC	Plan: 1644	1644sf three story SFR w	2018
New	Approved Basic 18-117368BP	2015 IRC	PLAN: 1516	1516sf Three Story SF	2018
New	Approved Basic 18-117385BP	2015 IRC	PLAN: 1742	1742sf Three Story SFR with	2018
New	Approved Basic 18-117385BP	2015 IRC	PLAN: 1742	1742sf Three Story SFR with	2018
New	Approved Basic 18-117490BP	2015 IRC	1858	3 story 3 bedroom SFR with attached	2018
New	Approved Basic 18-117490BP	2015 IRC	1858	3 story 3 bedroom SFR with attached	2018
New	Approved Basic 18-117385BP	2015 IRC	PLAN: 1742	1742sf Three Story SFR with	2018
New	Approved Basic 18-117368BP	2015 IRC	PLAN: 1516	1516sf Three Story SF	2018
New	Approved Basic 18-117368BP	2015 IRC	PLAN: 1516	1516sf Three Story SF	2018
New	Approved Basic 18-117490BP	2015 IRC	1858	3 story 3 bedroom SFR with attached	2018
New	Approved Basic 18-117368BP	2015 IRC	PLAN: 1516	1516sf Three Story SF	2018
New	Approved 18-117682BP	2015 IRC	PLAN: 2019	2019sf three story SFR with attached	2018
New	Approved Basic 18-117368BP	2015 IRC	PLAN: 1516	1516sf Three Story SF	2018
New	Approved Basic 18-117368BP	2015 IRC	PLAN: 1516	1516sf Three Story SF	2018
New	Approved Basic 18118212BP	2015IRC	Plan 1644	3 story 3 Bedroom with attached garage	2018
New	Approved Basic 18118212BP	2015IRC	Plan 1644	3 story 3 Bedroom with attached garage	2018
New	Approved Basic 18-117368BP	2015 IRC	PLAN: 1516	1516sf Three Story SF	2018
New	Approved Basic 18118212BP	2015IRC	Plan 1644	3 story 3 Bedroom with attached garag	2018
New	Approved Basic 18-117368BP	2015 IRC	PLAN: 1516	1516sf Three Story SF	2018
New	Approved Basic 18118212BP	2015IRC	Plan 1644	3 story 3 Bedroom with attached garage	2018
New	Approved basic 17-105451 BP	2015 IRC	Plan# 2477 (38#)	2 story SI	2018
New	Approved Basic 18114057BP	2015IRC	2500A	2 story with attached garage.	2018
New	Approved Basic 18114057BP	2015IRC	2500A	2 story with attached garage.	2018
New	Approved Basic 18114068BP	2015IRC	2500B	2 story with attached garage.	2018
New	Approved Basic 18114057BP	2015IRC	2500A	2 story with attached garage.	2018
New	Approved Basic 18114045BP	2015IRC	2011B	2 story with attached garage.	2018
New	Approved Basic 18114036BP	2015IRC	2011A	2 story with attached garage.	2018
New	Approved Basic 18114045BP	2015IRC	2011B	2 story with attached garage.	2018
New	Approved Basic 18114036BP	2015IRC	2011A	2 story with attached garage.	2018
New	New 2-story SFR of 2665 square feet with 555 sq ft attached garage.				2018
New	Approved Basic 18-117375BP	2015IRC	PLAN: 2441	2441sf two story SFR with	2018
New	EPERMIT Description of Work: Construct a single family home				2018
New	Approved Basic 18-117371BP	2015 IRC	PLAN: 2830	2830sf two story SFR with a	2018
New	Approved Basic 18-117371BP	2015 IRC	PLAN: 2830	2830sf two story SFR with a	2018
New	Approved basic 17-105451 BP	2015 IRC	Plan# 2477 (38#)	2 story SI	2018
New	Approved basic 16-118177 BP	2015 IRC	Plan# 2370	2-story sfr w/	2018
New	Approved basic 16-118188 BP	2015 IRC	Plan# 1704	Rambler w/finish	2018
New	Approved basic 16-118176 BP	2015 IRC	Plan# 2541	2-story sfr w	2018

Accessory Dwelling Units

Index # - File Name: 1.0022 - Single Family Dwellings Data\_Snohomish County.pdf

New	Approved basic 16-118186 BP	2015 IRC	Plan# 2060	Rambler w/atta	2018
New	Approved basic 16-118176 BP	2015 IRC	Plan# 2541	2-story sfr w	2018
New	Approved basic 16-118188 BP	2015 IRC	Plan# 1704	Rambler w/finishe	2018
New	Approved basic 16-118177 BP	2015 IRC	Plan# 2370	2-story sfr w/	2018
New	Approved basic 16-118188 BP	2015 IRC	Plan# 1704	Rambler w/finishe	2018
New	Approved basic 17-105451 BP	2015 IRC	Plan# 2477 (38#)	2 story SI	2018
New	Approved basic 16-118185 BP	2015 IRC	Plan# 2537	2-story sfr w/	2018
New	Approved Basic 18118272 BP	2015 IRC	Plan# Kimball 2 C D	2-story sfr w/at	2018
New	Approved basic 16-113033 BP	2015 IRC	Plan# Rainier D	2-story sfr w/attached g	2018
New	Approved basic 16-113867 BP	2015 IRC	Plan# Newhalem D	2-story sfr w/attache	2018
New	Approved Basic 16-113032 BP	2015 IRC	Plan# Rainier C	2-story sfr w/attached g	2018
New	Approved basic 16-109065 BP	2015 IRC	Plan# Pilchuck C/D	2-story sfr w/attac	2018
New	Approved basic 16-109065 BP	2015 IRC	Plan# Pilchuck C/D	2-story sfr w/attac	2018
New	Approved Basic 18 116039BP	2015 irc	Trafton 2-C	2410 Sq ft 4 bedroom with attached g	2018
New	Approved Basic 18118272 BP	2015 IRC	Plan# Kimball 2 C D	2-story sfr w/at	2018
New	Approved basic 16-113033 BP	2015 IRC	Plan# Rainier D	2-story sfr w/attached g	2018
New	Approved Basic 18 116043BP	2015 irc	Trafton 2-D	2410 Sq ft 4 bedroom with attache	2018
New	Approved Basic 18118272 BP	2015 IRC	Plan# Kimball 2 C D	2-story sfr w/at	2018
New	Approved Basic 18 116039BP	2015 irc	Trafton 2-C	2410 Sq ft 4 bedroom with attached	2018
New	Approved basic 16-113867 BP	2015 IRC	Plan# Newhalem D	2-story sfr w/attache	2018
New	Approved Basic 18118272 BP	2015 IRC	Plan# Kimball 2 C D	2-story sfr w/at	2018
New	Approved Basic 16-113032 BP	2015 IRC	Plan# Rainier C	2-story sfr w/attached g	2018
New	Approved Basic 18 116043BP	2015 irc	Trafton 2-D	2410 Sq ft 4 bedroom with attache	2018
New	Approved basic 16-113033 BP	2015 IRC	Plan# Rainier D	2-story sfr w/attached g	2018
New	Approved Basic 18118272 BP	2015 IRC	Plan# Kimball 2 C D	2-story sfr w/at	2018
New	Approved basic 16-113865 BP	2015 IRC	Plan # Newhalem C	2-story sfr w/atta	2018
New	Approved Basic 18118272 BP	2015 IRC	Plan# Kimball 2 C D	2-story sfr w/at	2018
New	Approved basic 16-113865 BP	2015 IRC	Plan # Newhalem C	2-story sfr w/atta	2018
New	Approved Basic 16-113032 BP	2015 IRC	Plan# Rainier C	2-story sfr w/attached g	2018
New	approved Basic 18118272 BP	2015 IRC	Plan# Kimball 2 C D	2-story sfr w/at	2018
New	Approved basic 16-113867 BP	2015 IRC	Plan# Newhalem D	2-story sfr w/attache	2018
New	Approved Basic 18118272 BP	2015 IRC	Plan# Kimball 2 C D	2-story sfr w/at	2018
New	Approved basic 16-118030 BP	2015 IRC	Plan# 2052-16	2-story sfr w/a	2018
New	Approved basic 16-118030 BP	2015 IRC	Plan# 2052-16	2-story sfr w/a	2018
New	Approved basic 16-118030 BP	2015 IRC	Plan# 2052-16	2-story sfr w/a	2018
New	Approved basic 16-118030 BP	2015 IRC	Plan# 2052-16	2-story sfr w/a	2018
New	Approved basic 16-118030 BP	2015 IRC	Plan# 2052-16	2-story sfr w/a	2018
New	Approved basic 16-118030 BP	2015 IRC	Plan# 2052-16	2-story sfr w/a	2018
New	Approved Basic 17-109422	2015 IRC	PLAN# 2417-2015	2417sf two str	2018
New	Approved Basic 17-109422	2015 IRC	PLAN# 2417-2015	2417sf two str	2018
New	Approved Basic 18-101613 BP	2015 IRC	PLAN: 2190B	2190sf two story SFR with	2018
New	Approved basic 17-100312 BP	2015 IRC	Plan# 2501A	2-story sfr w/attache	2018
New	Approved basic 16-121135 BP	2015 IRC	Plan# 2825A	2-story sfr w/attache	2018
New	Approved basic 16-111597 BP	2015 IRC	Plan# 2494A	2-story w/attache	2018
New	Approved basic 17-100312 BP	2015 IRC	Plan# 2501A	2-story sfr w/attache	2018
New	Approved basic 16-111597 BP	2015 IRC	Plan# 2494A	2-story w/attache	2018
New	Revision to issued permit 18-119908 RK changing to Approved basic 16-111598 BP	2015			2018

Accessory Dwelling Units

Index # - File Name: 1.0022 - Single Family Dwellings Data\_Snohomish County.pdf

New	Approved basic 17-100313 BP	2015 IRC	Plan# 2501B	2-story sfr w/attachec	2018
New	Approved basic 16-121135 BP	2015 IRC	Plan# 2825A	2-story sfr w/attach	2018
New	Approved basic 16-111597 BP	2015 IRC	Plan# 2494A	2-story w/attachec	2018
New	Approved basic 17-100304 BP	2015 IRC	Plan# 3222B	2-story sfr w/finishec	2018
New	**resubmittal of 18-118556 RK, referenced wrong basic. expedited to customer, no QAQC nece				2018
New	Approved Basic 17-108108BP	2015 IRC	PLAN# 3395A	2 Story SFR w/E	2018
New	Approved Basic 17-108109 BP	2015 IRC	PLAN#: 3395B	3395SF two story SF	2018
New	This permit is to revise issued permit 18-119913 rK changing structural plans to Approved Basic				2018
New	Approved basic 17-100312 BP	2015 IRC	Plan# 2501A	2-story sfr w/attache	2018
New	Approved basic 16-121137 BP	2015 IRC	Plan# 2825C	2-story sfr w/attac	2018
New	Approved basic 17-100312 BP	2015 IRC	Plan# 2501A	2-story sfr w/attache	2018
New	Approved basic 16-121137 BP	2015 IRC	Plan# 2825C	2-story sfr w/attac	2018
New	Approved basic 16-111597 BP	2015 IRC	Plan# 2494A	2-story w/attachec	2018
New	Approved basic 16-121135 BP	2015 IRC	Plan# 2825A	2-story sfr w/attach	2018
New	Approved basic 17-100313 BP	2015 IRC	Plan# 2501B	2-story sfr w/attachec	2018
New	Approved basic 16-111598 BP	2015 IRC	Plan# 2494B	2-story w/attached	2018
New	Approved basic 17-100312 BP	2015 IRC	Plan# 2501A	2-story sfr w/attache	2018
New	Approved basic 16-121137 BP	2015 IRC	Plan# 2825C	2-story sfr w/attac	2018
New	Approved basic 16-111597 BP	2015 IRC	Plan# 2494A	2-story w/attachec	2018
New	Approved basic 17-100313 BP	2015 IRC	Plan# 2501B	2-story sfr w/attachec	2018
New	Approved basic 16-121135 BP	2015 IRC	Plan# 2825A	2-story sfr w/attach	2018
New	Approved basic 16-111597 BP	2015 IRC	Plan# 2494A	2-story w/attachec	2018
New	Approved basic 16-118186 BP	2015 IRC	Plan# 2060	Rambler w/atta	2018
New	Approved basic 17-105451 BP	2015 IRC	Plan# 2477 (38#)	2 story SI	2018
New	2 story sfr				2018
New	2 story sfr				2018
New	New two story split level with attached garages				2018
New	Approved basic 16-118185 BP	2015 IRC	Plan# 2537	2-story sfr w/	2018
New	Approved basic 17-105451 BP	2015 IRC	Plan# 2477 (38#)	2 story SI	2018
New	Approved basic 16-118177 BP	2015 IRC	Plan# 2370	2-story sfr w/	2018
New	Approved basic 16-118176 BP	2015 IRC	Plan# 2541	2-story sfr w	2018
New	Approved basic 17-105451 BP	2015 IRC	Plan# 2477 (38#)	2 story SI	2018
New	Approved basic 16-118185 BP	2015 IRC	Plan# 2537	2-story sfr w/	2018
New	Approved basic 16-118177 BP	2015 IRC	Plan# 2370	2-story sfr w/	2018
New	Approved basic 16-118186 BP	2015 IRC	Plan# 2060	Rambler w/atta	2018
New	Approved basic 16-118176 BP	2015 IRC	Plan# 2541	2-story sfr w	2018
New	Approved basic 16-118186 BP	2015 IRC	Plan# 2060	Rambler w/atta	2018
New	Approved basic 16-118177 BP	2015 IRC	Plan# 2370	2-story sfr w/	2018
New	Approved basic 16-118186 BP	2015 IRC	Plan# 2060	Rambler w/atta	2018
New	New SFR creating 5, 915 sq. ft. of hard surfaces				2018
New	New SFR creating 5,931 sq. ft. of new hard surfaces				2018
New	Expiration date extended 120 days per Emergency Ordinance 20-027 Approved Basic 18-122964				2018
New	Approved Basic 18-122955 BP	2015 IRC	PLAN: 2582B	2582sf three story SFR with	2018
New	Approved Basic 18-122960BP	2015 IRC	PLAN: 2497B	2497sf three story SFR with	2018
New	Approved Basic 18-122961BP	2015 IRC	PLAN: 2581 A	2581sf three story SFR \	2018
New	Approved Basic 18-122971BP	2015 IRC	PLAN: 2581B	2581sf three story SFR with at	2018
New	Approved Basic 18-122957BP	2015 IRC	PLAN: 2525A	2525sf two story SFR with ;	2018

Accessory Dwelling Units

Index # - File Name: 1.0022 - Single Family Dwellings Data\_Snohomish County.pdf

New	Approved Basic 18-122956BP	2015 IRC	PLAN: 2582C	2582sf three story SFR with	2018
New	2045 s.f. rambler w/attached garage & carport				2018
New	Approved basic 17-103906 BP	2015 IRC	Plan 1896	2 story with	2018
New	Approved basic 17-103906 BP	2015 IRC	Plan 1896	.3 story with	2018
New	Approved basic 17-103906 BP	2015 IRC	Plan 1896	3 story sfr w	2018
New	Approved basic 17-103906 BP	2015 IRC	Plan 1896	3 story sfr w	2018
New	Approved basic 17-103905 BP	2015 IRC	Plan 1668	2 story with at	2018
New	Expiration date extended 120 days per Emergency Ordinance 20-027 Covid19 related 30 day ext				2018
New	1584 square foot SFR with attached Garage				2018
New	Two story SFR with attached Garage				2018
New	Approved Basic 18-120929BP	2015 IRC	PLAN: 2418ABC v 2	2418sf three story	2018
New	Approved Basic 17-119362 BP	2015 IRC	PLAN: 2175 AB 2015	2175sf three story SFR	2018
New	Approved Basic 17-118650 BP	2015 IRC	PLAN: 2431 AB	2431sf three story S	2018
New	Approved Basic 17-118650 BP	2015 IRC	PLAN: 2431 AB	2431sf three story S	2018
New	Approved Basic 18-120929BP	2015 IRC	PLAN: 2418ABC v 2	2418sf three story	2018
New	Approved Basic 18-120929BP	2015 IRC	PLAN: 2418ABC v 2	2418sf three story	2018
New	Approved Basic 18-120929BP	2015 IRC	PLAN: 2418ABC v 2	2418sf three story	2018
New	Approved Basic 17-118650 BP	2015 IRC	PLAN: 2431 AB	2431sf three story S	2018
New	Approved Basic 17-119362 BP	2015 IRC	PLAN: 2175 AB 2015	2175sf three story SFR	2018
New	Approved Basic 17-118650 BP	2015 IRC	PLAN: 2431 AB	2431sf three story S	2018
New	Approved Basic 18-120929BP	2015 IRC	PLAN: 2418ABC v 2	2418sf three story	2018
New	Approved Basic 18-120927BP	IRC: 2015	PLAN: 2210EF	2210sf three story SFR wit	2018
New	Approved Basic 18-122956BP	2015 IRC	PLAN: 2582C	2582sf three story SFR with	2018
New	Approved basic 17-105451 BP	2015 IRC	Plan# 2477 (38#)	2 story SI	2018
New	2018 28 X 52 Double-Wide Mobile Home				2018
New	1885 s.f. rambler w/attached garage				2018
New	2277 s.f. rambler w/attached garage				2018
New	New Mobile Home				2018
New	New mobile home				2018
New	New mobile home				2018
New	Detached Accessory Apartment: 701 square feet living space and 177 sf storage ***Permit to re				2018
New	Expiration date extended 120 days per Emergency Ordinance 20-027 EPERMIT Description of W				2018
New	EPERMIT Description of Work: construction of new single family residence and associated utiliti				2018
New	Approved basic 16-120708 BP	2015 IRC	Plan# 3484	2-story sfr w/attache	2018
New	Approved Basic 17-116665 BP	2015 IRC	PLAN # 3745	Two story SFR with attached g	2018
New	Expiration date extended 120 days per Emergency Ordinance 20-027 Approved Basic 18-112025				2018
New	Approved basic 16-114079 BP	2015 IRC	Plan# 2766	2766 s.f. rambler w/att	2018
New	Approved basic 16-113274 BP	2015 IRC	Plan# Mason C	2-story sfr w/attached g	2018
New	Approved Basic 18-117511BP	2015 IRC	PLAN: Olympic C/D	2980sf two story SFF	2018
New	Approved Basic 18118272 BP	2015 IRC	Plan# Kimball 2 C D	2-story sfr w/at	2018
New	Approved basic 16-113275 BP	2015 IRC	Plan# Mason D	2-story sfr w/attached g	2018
New	Approved Basic 18-118171BP	2015 IRC	3308 sq.ft. Plan Cascade 2 D	2 story 6 bedroc	2018
New	Approved Basic 18-118172BP	2015 IRC	3293 sq.ft.	2 story 6 bedroom SFR with atta	2018
New	Approved basic 16-113274 BP	2015 IRC	Plan# Mason C	2-story sfr w/attached g	2018
New	Approved Basic 18-118171BP	2015 IRC	3308 sq.ft.	2 story 6 bedroom SFR with atta	2018
New	Expiration date extended 120 days per Emergency Ordinance 20-027 Approved basic 16-11327				2018
New	Approved basic 16-113274 BP	2015 IRC	Plan# Mason C	2-story sfr w/attached g	2018



Accessory Dwelling Units

Index # - File Name: 1.0022 - Single Family Dwellings Data\_Snohomish County.pdf

New	Approved Basic 18118272 BP	2015 IRC	Plan# Kimball 2 C D	2-story sfr w/at	2018
New	Approved Basic 18-118172BP	2015 IRC	3293 sq.ft.	2 story 6 bedroom SFR with atta	2018
New	Approved Basic 18118272 BP	2015 IRC	Plan# Kimball 2 C D	2-story sfr w/at	2018
New	Approved Basic 18 116043BP	2015 irc	Trafton 2-D	2410 Sq ft 4 bedroom with attached	2018
New	Approved Basic 18118272 BP	2015 IRC	Plan# Kimball 2 C D	2-story sfr w/at	2018
New	Approved Basic 18 116039BP	2015 irc	Trafton 2-C	2410 Sq ft 4 bedroom with attached	2018
New	Approved Basic 18-118171BP	2015 IRC	3308 sq.ft.	2 story 6 bedroom SFR with atta	2018
New	Approved basic 16-113274 BP	2015 IRC	Plan# Mason C	2-story sfr w/attached g	2018
New	Approved basic 16-113033 BP	2015 IRC	Plan# Rainier D	2-story sfr w/attached g	2018
New	Approved Basic 16-113032 BP	2015 IRC	Plan# Rainier C	2-story sfr w/attached g	2018
New	Approved Basic 18 116039BP	2015 irc	Trafton 2-C	2410 Sq ft 4 bedroom with attached	2018
New	Approved Basic 18118272 BP	2015 IRC	Plan# Kimball 2 C D	2-story sfr w/at	2018
New	Approved basic 16-113275 BP	2015 IRC	Plan# Mason D	2-story sfr w/attached g	2018
New	Approved Basic 18-118171BP	2015 IRC	3308 sq.ft.	Plan Cascade 2 D 2 story 6 bedroc	2018
New	Approved Basic 18118272 BP	2015 IRC	Plan# Kimball 2 C D	2-story sfr w/at	2018
New	Approved basic 16-113275 BP	2015 IRC	Plan# Mason D	2-story sfr w/attached g	2018
New	Approved Basic 18118272 BP	2015 IRC	Plan# Kimball 2 C D	2-story sfr w/at	2018
New	Approved Basic 18-120454BP	2015 IRC	PLAN: SeaRun1-5-6	3003sf two story SFR with	2018
New	Approved Basic 18-120455BP	2015 IRC	PLAN: SeaRun3-4	3289sf two story SFR wit	2018
New	Approved Basic 18-120455BP	2015 IRC	PLAN: SeaRun3-4	3289sf two story SFR wit	2018
New	Approved Basic 18-120454BP	2015 IRC	PLAN: SeaRun1-5-6	3003sf two story SFR with	2018
New	Approved Basic 18-120454BP	2015 IRC	PLAN: SeaRun1-5-6	3003sf two story SFR with	2018
New	Approved basic 16-114982 BP	2015 IRC	Plan# 3072	2-story sfr w/attached g	2018
New	Approved basic 16-114982 BP	2015 IRC	Plan# 3072	2-story sfr w/attached g	2018
New	Cover existing patio				2018
New	Approved Basic 17109022BP	2015 IRC	PLAN# 3019	3019sf two stor	2018
New	1884 s.f. sfingle family residence w/1884 s.f. unfinished & unheated basement & attached gara				2018
New	New 2 story SFR				2018
New	Approved basic 16-118182 BP	2015 IRC	Plan# 2972	2-story sfr w	2018
New	Approved basic 16-121949 BP	2015 IRC	Plan# 2578	Rambler w/atta	2018
New	New 3725 sqyare foot SFR with daylight basement, attached garage of 1032 sq ft, covered deck				2018
New	2805 square foot SFR with attached Garage				2018
New	New SFR				2018
New	New two story SFR with attached garage creating a total (with driveway) of 5,148 sq. ft. of hard				2018
New	2 story Single Family Home				2018
New	New single family dwelling				2018
New	New SFR				2018
New	1649 square foot SFR with 898 square foot finished Basement and attached Garage				2018
New	2 story sfr				2018
New	2 story duplex				2018
New	30 day extension - trogers Two Story SFR with attached Garage				2018
New	Expiration date extended 120 days per Emergency Ordinance 20-027 EPERMIT Description of W				2018
New	New 2 story house with attached garage and secondary living suite as part of the residence. Coi				2018
New	1209 sf rambler				2018
New	Approved Basic 17-118289BP	2015 IRC	PLAN: Parkland Place	2791sf two story :	2018
New	Approved Basic 17-118289BP	2015 IRC	PLAN: Parkland Place	2791sf two story :	2018
New	Approved basic 16-118177 BP	2015 IRC	Plan# 2370	2-story sfr w/	2018

Accessory Dwelling Units

Index # - File Name: 1.0022 - Single Family Dwellings Data\_Snohomish County.pdf

New	Expiration date extended 120 days per Emergency Ordinance 20-027	1952 square foot SFR with	2018
New	Approved basic 16-118185 BP	2015 IRC Plan# 2537	2-story sfr w/ 2018
New	Approved basic 17-105451 BP	2015 IRC Plan# 2477 (38#)	2 story SI 2018
New	Approved basic 16-118177 BP	2015 IRC Plan# 2370	2-story sfr w/ 2018
New	Approved basic 17-100203 BP	2015 IRC Plan# 2254 (25#)	Rambler w 2018
New	2 story sfr w/attached garage		2018
New	2 story sfr w/attached garage		2018
New	Water Use Covenant AFN: 201807270254	2242 square foot SFR with 538 square foot attached	2018
New	New SFR		2018
New	Two story SFR with finished Basement & attached Garage		2018
New	Approved Basic 17-112334 BP	2015 IRC PLAN: 3134-03CD RV	3134sf two 2018
New	Approved Basic 17109487BP	2015 IRC 2768-03AB 2768Sq. Ft.	SFR with 3 car attached garage 2018
New	Approved basic 17-103633 BP	2015 IRC Plan 2588-03AB	Rambler w/attached garage 2018
New	Two story SFR with finished Basement & attached Garage		2018
New	Two story SFR with finished Basement & attached Garage		2018
New	Landslide Hazard Area AFN: 201806050760	CASP AF# _____	New SF 2018
New	Two story SFR with finished Basement & attached Garage		2018
New	Approved basic 16-114079 BP	2015 IRC Plan# 2766	2766 s.f. rambler w/att 2018
New	Approved Basic 18-113732 BP	2015 IRC PLAN#: 2212Vault	2212sf Rambler with attac 2018
New	Approved basic 16-114079 BP	2015 IRC Plan# 2766	2766 s.f. rambler w/att 2018
New	Approved Basic 18-113732 BP	2015 IRC PLAN#: 2212Vault	2212sf Rambler with attac 2018
New	Approved basic 16-114079 BP	2015 IRC Plan# 2766	2766 s.f. rambler w/att 2018
New	Approved basic 17-103633 BP	2015 IRC Plan 2588-03AB	Rambler w/attached gara 2018
New	Approved basic 17-103633 BP	2015 IRC Plan 2588-03AB	Rambler w/attached gara 2018
New	EPERMIT Description of Work: Construct new single family residence 2018		
New	Approved Basic 17-109019 BP	2015 IRC Plan# 3588-03AB	3588sf two story SFR 2018
New	Approved basic 17-103633 BP	2015 IRC Plan 2588-03AB	Rambler w/attached gara 2018
New	Approved Basic 17109487BP	2015 IRC 2768-03AB 2768Sq. Ft.	SFR with 3 car attached garage 2018
New	Permit to change basic from 16-120669 BP to 18-112025 BP	PLAN: 3044 2x10	3044sf two story 2018
New	Approved Basic 17-110805BP	2015 IRC PLAN: 3023	3023sf two story S 2018
New	Approved Basic 18-101302BP	2015 IRC PLAN#3350	3350SF single family re 2018
New	Approved basic 16-114079 BP	2015 IRC Plan# 2766	2766 s.f. rambler w/att 2018
New	Approved basic 16-114058 BP	2015 IRC Plan# 2212	2212 s.f. rambler w/atl 2018
New	Revised site plan approved 7/10/18 S. Steepy	Approved basic 16-114079 BP	2015 IRC 2018
New	Approved Basic 18-1136731BP	2015 IRC PLAN#: 3876	3876sf two story SFR with atta 2018
New	Approved Basic 17-110805BP	2015 IRC PLAN: 3023	3023sf two story S 2018
New	Approved Basic 18-113732 BP	2015 IRC PLAN#: 2212Vault	2212sf Rambler with attac 2018
New	Approved Basic 18-101302BP	2015 IRC PLAN#3350	3350SF single family re 2018
New	Approved Basic 18100014BP	2015 IRC 3634	3634 sq ft 2 story with attached garage. 2018
New	Approved basic 16-120708 BP	2015 IRC Plan# 3484	2-story sfr w/attache 2018
New	EPERMIT Description of Work: Construct 1 story single family residence with 3 car garage and d 2018		
New	EPERMIT Description of Work: Construct new 3648 sqft single family residence with 1,101 sq fo 2018		
New	Approved basic 17-103633 BP	2015 IRC Plan 2588-03AB	Rambler w/attached gara 2018
New	2018 40 5 X 70 Triple-wide Mobile Home 2018		
New	2 story w/153 s.f. finished basement and attached garage 2018		
New	Approved basic 16-120669 BP	2015 IRC Plan# 3044	2-story sfr w/ attac 2018
New	2218 s.f. rambler w/attached garage 2018		

Accessory Dwelling Units

Index # - File Name: 1.0022 - Single Family Dwellings Data\_Snohomish County.pdf

New	Airport Influence Area Disclosure AFN: 201803210322	Approved basic 16-118186 BP			2018
New	Airport Influence Area Disclosure AFN: 201803210321	Approved basic 17-105451 BP			2018
New	Approved basic 16-118186 BP	2015 IRC	Plan# 2060	Rambler w/atta	2018
New	2 story sfr /attached garage				2018
New	New 2-story SFR w/attached garage				2018
New	New 2-story SFR w/finished basement & attached garage				2018
New	New 2-story SFR w/finished basement & attached garage				2018
New	Approved basic 16-111714 BP	2015 IRC	Plan# 2014 plan	2- story SFR w/attached g	2018
New	Approved Basic 16-115219 BP	2015 IRC	Plan# 2165	2-story SFR w/ attached gar	2018
New	This application was sent a notice of pending application expiration on April 11, 2017, and will e				2018
New	35 x 35 new single family residence lot # 8 Lynnwood SFDU				2018
New	35 x 35 new single family residence lot #9 Lynnwood SFDU				2018
New	35 x 35 new single family residence lot # 10 Lynnwood SFDU				2018
New	Detached accessory apartment with garage				2018
New	1 story, 805sf detached accessory apartment				2018
New	New Rambler				2018
New	Expiration date extended 120 days per Emergency Ordinance 20-027 2 story single family home				2018
New	Approved Basic 17-106874 BP	2015 IRC	Plan # 2138	2138sf 2 story	2018
New	Approved basic 16-122036 BP	2015 IRC	Plan# 2418 AB 2015	3-story sfr v	2018
New	2 story sfr w/attached garage Sent RSP to SHD 12/8/17 and to Jack Hurley (approved )to review				2018
New	2 story w/attached garage				2018
New	2 story sfr w/attached garage RSP submitted 4/12/18 - approved 5/8/18 by SHD				2018
New	2 story sfr w/attached garage				2018
New	2 story sfr w/attached garage				2018
New	2 story w/attached garage				2018
New	2 story sfr w/attached garage				2018
New	New 2-story 2654 sq ft residence with attached 726 sq ft garage.				2018
New	Approved basic 16-111598 BP	2015 IRC	Plan# 2494B	2-story w/attached	2018
New	Approved basic 16-111597 BP	2015 IRC	Plan# 2494A	2-story w/attache	2018
New	Approved basic 16-121137 BP	2015 IRC	Plan# 2825C	2-story sfr w/attac	2018
New	Approved basic 17-100313 BP	2015 IRC	Plan# 2501B	2-st	2018
New	Approved Basic 17-108112 BP	2015 IRC	Plan # 3471 A	3471sf three story SF	2018
New	Approved Basic 18-120419BP	2015 IRC	PLAN#: 3316-A	3316SF two story SFR with	2018
New	Approved Basic 17-108111BP	2015 IRC	Plan #3471	3471sf three st	2018
New	Approved 17-108022 BP	2015 IRC	Plan# 3316 B	3316 3 story residenc	2018
New	Expiration date extended 120 days per Emergency Ordinance 20-027 2 story sfr w/attached gara				2018
New	Expiration date extended 120 days per Emergency Ordinance 20-027 2 story sfr w/attached gara				2018
New	Expiration date extended 120 days per Emergency Ordinance 20-027 2 story sfr w/attached gara				2018
New	Approved basic 16-118177 BP	2015 IRC	Plan# 2370	2-story sfr w/	2018
New	New 2-story sfr w/attached garage on approved basic 16-118176 BP				2018
New	Approved basic 16-118183 BP	2015 IRC	Plan# 3049	2-story sfr w/	2018
New	368sf Single Family Residence				2018
New	Approved basic 16-118187 BP	2015 IRC	Plan# 2060 (38#)	Rambler	2018
New	Approved basic 16-118176 BP	2015 IRC	Plan# 2541	2-story sfr w	2018
New	Approved basic 16-118177 BP	2015 IRC	Plan# 2370	2-story sfr w/	2018
New	Approved Basic 17-108805BP	2015 IRC	PLAN# Harlequin 1784	1784sf 2 st	2018
New	New rambler based on previously approved basic 17-100203 BP				2018

Accessory Dwelling Units

Index # - File Name: 1.0022 - Single Family Dwellings Data\_Snohomish County.pdf

New	Approved basic 17-100203 BP	2015 IRC	Plan# 2254 (25#)	Rambler w	2018
New	Approved basic 16-118177 BP	2015 IRC	Plan# 2370	2-story sfr w/	2018
New	Approved basic 17-100203 BP	2015 IRC	Plan# 2254 (25#)	Rambler w	2018
New	Expiration date extended 120 days per Emergency Ordinance 20-027 SFR: two story style home				2018
New	2 story sfr with attached garage				2018
New	1912 sf rambler w/attached garage				2018
New	Rambler w/attached garage				2018
New	1957 sf rambler w/attached garage				2018
New	Approved basic 16-118186 BP	2015 IRC	Plan# 2060	Rambler w/atta	2018
New	Approved Basic 17-108805BP	2015 IRC	PLAN# Harlequin 1784	1784sf 2 st	2018
New	Approved basic 17-100203 BP	2015 IRC	Plan# 2254 (25#)	Rambler w	2018
New	Approved Basic 17-108805BP	2015 IRC	PLAN# Harlequin 1784	1784sf 2 st	2018
New	Approved basic 17-100203 BP	2015 IRC	Plan# 2254 (25#)	Rambler w	2018
New	Approved basic 16-118186 BP	2015 IRC	Plan# 2060	Rambler w/atta	2018
New	Approved basic 16-114982 BP	2015 IRC	Plan# 3072	2-story sfr w/attached g	2018
New	New 3070 sq ft 2 story house with attached garage. Site preparation under issued LDA 17-1155				2018
New	Expiration date extended 120 days per Emergency Ordinance 20-027 New 4 bedroom single fam				2018
New	New 2 story SFR with rooftop hot tub and attached garage.				2018
New	1385 square foot SFR with 860 square foot covered Deck				2018
New	EPERMIT Description of Work: Construct single family residence for primary use. 18-122255LD				2018
New	2 story w/attached garage				2018
New	3 story sfr w/attached garage				2018
New	3 story sfr w/ attached garage				2018
New	3 story sfr w/attached garage				2018
New	3 story sfr w/attached garage				2018
New	3 story sfr w/attached garage				2018
New	3 story sfr w/attached garage				2018
New	3 story sfr w/attached garage				2018
New	3 story sfr w/attached garage				2018
New	3 story sfr w/attached garage				2018
New	3 story sfr w/attached garage				2018
New	Expiration date extended 120 days per Emergency Ordinance 20-027 2-story sfr no garage				2018
New	3 story sfr w/attached garage				2018
New	3 story sfr w/attached garage				2018
New	3 story sfr w/attached garage				2018
New	3 story sfr w/attached garage				2018
New	3 story sfr w/ attached garage				2018
New	SFR: new rambler style home with finished basement and attached garage				2018
New	New 2018 40 x 27 double-wide mobile home				2018
New	New SFR with attached garage Airport Disclosure Notice AFN# 201804110164				2018
New	2218 Rambler w/attached garage				2018
New	2 story sfr w/attached garage				2018
New	2218 Rambler w/attached garage				2018
New	3943 sf 2 story sfr with 803 sf attached garage AFN: 201807180509 Water Use Covenant				2018
New	EPERMIT Description of Work: 1950 square foot SFR with attached Garage				2018
New	EPERMIT Description of Work: Single family residence and driveway				2018
New	EPERMIT Description of Work: New construction. 1 story SFR. Land Disturbing Activity permit tr				2018

Accessory Dwelling Units

Index # - File Name: 1.0022 - Single Family Dwellings Data\_Snohomish County.pdf

New	EPERMIT Description of Work: SFR Site preparation and drainage reviewed under 18-101966-LI	2018
New	Approved Basic 18-116190 BP 2015 IRC 1736 - 50 Lb Snow Load 1736 square single story v	2018
New	Approved Basic 16-115219 BP 2015 IRC Plan# 2165 2-story SFR w/ attached ga	2018
New	Water Use Covenant AFN: 201806040314 Two story SFR	2018
New	1654 s.f. rambler w/attached garage	2018
New	1933 s.f. rambler w/attached garage	2018
New	EPERMIT Description of Work: New Single Family Residence with attached Garage	2018
New	EPERMIT Description of Work: Single Family Residence with attached Garage	2018
New	EPERMIT Description of Work: Construction of new single family residence and necessary utilitie	2018
New	EPERMIT Description of Work: Single Family Residence with attached Garage	2018
New	Expiration date extended 120 days per Emergency Ordinance 20-027 New 96 X 50 Single Family	2018
New	EPERMIT: new SFR, rambler style with attached 3-car garage *****documents under 181264	2018
New	New SFR	2018
New	2 story sfr w/attached garage	2018
New	1580 s.f. residence w/basement & attached garage	2018
New	New 72 x32 SFR	2018
New	2,725 sf SFR with 899 sf attached garage	2018
New	Single family residence w/daylight basement & attached garage 1/12/18 Derek Schneider came	2018
New	Expiration date extended 120 days per Emergency Ordinance 20-027 EPERMIT Description of W	2018
New	Expiration date extended 120 days per Emergency Ordinance 20-027 3488 square foot SFR with	2018
New	2 story sfr w/finished basement and attached garage	2018
New	Approved Basic 17109022BP 2015 IRC PLAN# 3019 3019sf two stor	2018
New	Approved basic 17-101506 BP 2015 IRC Plan# 3049 2-story sfr w/attached g	2018
New	Approved Basic 17-113335BP 2015 IRC 2664sf two story SFR with finished baser	2018
New	Approved Basic 17109022BP 2015 IRC PLAN# 3019 3019sf two stor	2018
New	Approved basic 17-101506 BP 2015 IRC Plan# 3049 2-story sfr w/attached g	2018
New	Approved basic 16-121633BP 2015 IRC Plan# 2458 Rambler style SFR w/	2018
New	Approved Basic 17-119001 BP 2015 IRC Plan 2552 2552 Sq. Ft rambler with attached	2018
New	Approved basic 17-105451 BP 2015 IRC Plan# 2477 (38#) 2 story SI	2018
New	Approved basic 17-101248 BP 2015 IRC Plan# 3656 2-story sfr w/attached g	2018
New	Approved Basic 17-113335BP 2015 IRC 2664sf two story SFR with finished baser	2018
New	New 2 story 4240 sq ft house with 945 sq ft attached garage.	2018
New	2 story sfr w/attached garage	2018
New	2 story sfr w/attached garage	2018
New	New 2 story 2592 sq ft combination stable and home with 384 sq ft deck. AFN 201807270054, v	2018
New	Expiration date extended 120 days per Emergency Ordinance 20-027 Two Story SFR with attach	2018
New	New 2457 square foot house with attached 670 square foot garage.	2018
New	EPERMIT Description of Work: New Construction of an ADU adjacent to an existing SFR. LDA is :	2018
New	New 3730 sf SFR with 3622 sf garage and covered deck/porch 30 day grace period given permit	2018
New	New SFR	2018
New	2 story sfr w/attached garage	2018
New	1288 square foot SFR	2018
New	New 1188sf Mobile Home	2018
New	New detached accessory apartment with attached garage, NOTE: the basement cannot be finish	2018
New	New 2 story SFR with garage attached by enclosed breezeway / heated space hallway. Garage h	2018
New	Expiration date extended 120 days per Emergency Ordinance 20-027 SFR: new single family hon	2018
New	Detached garage/shop w/second story living space (meeting room, office, bath)	2018

Accessory Dwelling Units

Index # - File Name: 1.0022 - Single Family Dwellings Data\_Snohomish County.pdf

New	288 square foot covered Deck				2018
New	EPERMIT E18-33936 Description of Work: Placement of a new manufactured home for a single f				2018
New	New SFR				2018
New	Approved basic 17-100203 BP	2015 IRC	Plan# 2254 (25#)	Rambler v	2018
New	2548 square foot SFR with 2nd floor unheated Storage				2018
New	Approved Basic 16-115219 BP	2015 IRC	Plan# 2165	2-story SFR w/ attached ga	2018
New	Approved Basic 16-115219 BP	2015 IRC	Plan# 2165	2-story SFR w/ attached ga	2018
New	New 2302 sq. ft. SFR				2018
New	Approved Basic 16-115219 BP	2015 IRC	Plan# 2165	2-story SFR w/ attached ga	2018
New	New 2 story 3123 square foot residence with attached garage and covered deck/porch.				2018
New	New 2 story 3002 sq ft house with 618 sq ft attached garage. Also includes 459 sq ft of covered				2018
New	Expiration date extended 120 days per Emergency Ordinance 20-027 Two story SFR with finishe				2018
New	New 2 story SFR with attached garage Later design by Wendell Reed, P.E. 30771				2018
New	New 2 story SFR Airport Disclosure Notice AFN# 201807240170				2018
New	Two story SFR with 1942 square foot finished Basement and attached Garage & Carport				2018
New	New detached accessory apartment				2018
New	Expiration date extended 120 days per Emergency Ordinance 20-027 New SFR				2018
New	New SFR				2018
New	2 story sfr w/attached garage				2018
New	1080 s.f. detached garage w/2nd story guest house				2018
New	Extended for Final due to snow. 11/22/2019 esp One month extesion \New SFR				2018
New	Water Use Covenant AFN: 201804200419 Rambler style SFR: 2750 sf living space with 1585 sf a				2018
New	2 story sfr w/attached garage				2018
New	EPERMIT Description of Work: Build a SFR for speculation				2018
New	Expiration date extended 120 days per Emergency Ordinance 20-027 EPERMIT Description of W				2018
New	Expiration date extended 120 days per Emergency Ordinance 20-027 EPERMIT Description of W				2018
New	EPERMIT Description of Work: Construction of new single family residence and associated utiliti				2018
New	New double wide Mobile Home with garage as basement underneath the mobile (17-119385 Af				2018
New	2018 40 x 70 mobile home				2018
New	Triple Wide MH for a detached Accessory Apartment				2018
New	EPERMIT Description of Work: Construct new single family residence 18-117269-LDA for clearir				2018
New	Expiration date extended 120 days per Emergency Ordinance 20-027 New SFR				2018
New	Approved basic 16-118185 BP	2015 IRC	Plan# 2537	2-story sfr w/	2018
New	Expiration date extended 120 days per Emergency Ordinance 20-027 EPERMIT Description of W				2018
New	New two story SFR with covered porch Submittal Documents in 18-124835-PRO				2018
New	Expiration date extended 120 days per Emergency Ordinance 20-027 Two Story SFR with attach				2018
New	New 74 x 42 single family residence.				2018
New	2 Story SFR with attached garage				2018
New	Converting existing SFR to Duplex				2018
New	New SFR				2018
New	New SFR				2018
New	New 2 story SFR with attached garage and covered deck areas.				2018
New	Expiration date extended 120 days per Emergency Ordinance 20-027 New SFR				2018
New	EPERMIT Description of Work: Construction of new Single Family home on lot A of Ventana Proj				2018
New	EPERMIT Description of Work: Construction of a new Single family home on Lot B in place of pre				2018
New	EPERMIT Description of Work: Construction of new single family home on Lot C.				2018
New	52 x 52 Single Family Residence				2018

Accessory Dwelling Units

Index # - File Name: 1.0022 - Single Family Dwellings Data\_Snohomish County.pdf

New	New 3523 sq ft SFR with attached 654 sq ft garage and a covered porch. Existing SFR (MH) to be	2018
New	Converting existing single family into a duplex	2018
New	Expiration date extended 120 days per Emergency Ordinance 20-027 New 2 story SFR	2018
New	Expiration date extended 120 days per Emergency Ordinance 20-027 2 story duplex w/attached	2018
New	Airport Influence Area Disclosure Notice AFN: 201803230278 Two story duplex	2018
New	2 story sfr w/attached garage	2018
New	Permit to get final on MH permit 05-118134 MH 1988 26 X 65 double-wide Mobile Home	2018
New	Expiration date extended 120 days per Emergency Ordinance 20-027 EPERMIT Description of W	2018
New	2198 square foot SFR with attached Garage AFN 21807300296 Water Use Covenant	2018
New	Expiration date extended 120 days per Emergency Ordinance 20-027 2 story SFR	2018
New	420 square foot Accessory Apartment and permit to get final on main floor 660 square foot Gar	2018
New	New duplex with 7 bedrooms per unit	2018
New	Expiration date extended 120 days per Emergency Ordinance 20-027 EPERMIT E18-21006 Descr	2018
New	16 x 44 Detached Accessory Apartment - 680 sf, 2 bedroom - Dec of Owner Occupancy: 20180	2018
New	EPERMIT Description of Work: Installation of Mobile Home on existing developed lot	2018
New	Two story SFR with attached Garage	2018
New	Expiration date extended 120 days per Emergency Ordinance 20-027 Replacing MH with Two st	2018
New	Two story SFR with attached Garage	2018
New	New SFR	2018
New	EPermit E18-32999 New 2- story 2642 sq ft house with attached garage.	2018
New	Permit to correct code violation of constructing without permits New 2 story, 2 bedroom, 850 s	2018
New	New 3681 sq ft 2 story SFR with attached 693 sq ft garage.	2018
New	Expiration date extended 120 days per Emergency Ordinance 20-027 Demolish and rebuild new	2018
New	New 48 x 74 Single Family Residence	2018
New	Approved basic 17-105451 BP 2015 IRC Plan# 2477 (38#) 2 story SI	2018
New	New SFR with attached accessory apartment	2018
New	Expiration date extended 120 days per Emergency Ordinance 20-027 New SFR **30 day extens	2018
New	New SFR - tax parcel to be 280612-002-037-00	2018
New	New 2964 square foot SFR with attached garage	2018
New	2341 sf rambler sfr w/ 775 sf attached garage	2018
New	2018 27 X 68 Double-Wide Mobile Home	2018
New	New 2 story single family residence w/attached garage	2018
New	02/25/2020 esp one month extension given. 546 sf attached accessory apartment and 312 sf co	2018
New	Two Story SFR with 2295 square foot attached Garage	2018
New	Detached accessory apartment above garage.	2018
New	2235 square foot SFR with attached Garage	2018
New	2017 14.8 x 49.4 Single-wide Guest House Mobile Home - Palm Harbor Homes - Paradise	2018
New	Expiration date extended 120 days per Emergency Ordinance 20-027 Rambler style sfr w/attach	2018
New	EPERMIT Description of Work: New single family residence.	2018
New	Expiration date extended 120 days per Emergency Ordinance 20-027 New SFR	2018
New	3963 square foot SFR with attached Garage and 800 square foot unheated storage. Application	2018
New	New 72 x 53- 61/2 SFR	2018
New	Covered porch attached to the house.	2018
New	Permit to construct a new 720 square foot detached accessory apartment.	2018
New	1323 s.f. rambler w/attached garage	2018
New	Expiration date extended 120 days per Emergency Ordinance 20-027 One month extension. 12/	2018
New	Expiration date extended 120 days per Emergency Ordinance 20-027 1657 square foot SFR with	2018

Accessory Dwelling Units

Index # - File Name: 1.0022 - Single Family Dwellings Data\_Snohomish County.pdf

New	To get permit for existing 1977 26 X 60 MH placed on property in 1977	2018
New	Approved Basic 16-115219 BP 2015 IRC Plan# 2165 2-story SFR w/ attached garage	2018
New	New SFR ***LDA in drawer waiting for- Revised site plan to SHD on 9/6/18 - PRM/PDS, then w	2018
New	New single story 1904 sf sfr w/attached 484 sf garage	2018
New	New 4 bedroom SFR on 1.47 acres	2018
New	New two story SFR	2018
New	Expiration date extended 120 days per Emergency Ordinance 20-027 **3/13/20 cst one time 30	2018
New	SFR: new 2 story style home with 2 car garage, 3 bedrooms, 3.5 bath with bonus room over gara	2018
New	New SFR	2018
New	New SFR with attached garage	2018
New	2249 square foot SFR with attached Garage	2018
New	11/5/19 cst One time 30 day extension. Must renew prior to 12/11/19 if needed. New rambler	2018
New	New 66 X 28 Mobile Home	2018
New	EPERMIT Description of Work: Remove old manufactured home and install same size unit in the	2018
New	New SFR	2018
New	Single Family Residence RSP approved 5/24/18	2018
New	Expiration date extended 120 days per Emergency Ordinance 20-027 Two story SFR with attach	2018
New	2 story sfr w/attached garage	2018
New	Expiration date extended 120 days per Emergency Ordinance 20-027 Two story SFR in existing fi	2018
New	2218 s.f. rambler w/attached garage	2018
New	20 x 20 single family residence	2018
New	Two story SFR with attached Garage	2018
New	Expiration date extended 120 days per Emergency Ordinance 20-027 ***10/16/2019 DJL- Talke	2018
New	2 story sfr w/attached garage	2018
New	EPERMIT Description of Work: Construction of New Single Family Residence on property develo	2018
New	EPERMIT Description of Work: New detached Garage with Accessory Apartment on second floor	2018
New	2 story SFR with attached garage	2018
New	2017 27 X 64 double-wide Mobile Home	2018
New	2 story sfr with attached garage	2018
New	Two Story SFR	2018
New	2434 square foot SFR with attached Garage	2018
New	New single family rambler	2018
New	New 2186 sq ft SFR with 724 sq ft attached garage	2018
New	Moving wall in SFR	2018
New	New SFR with attached garage One time 30 day extension	2018
New	Expiration date extended 120 days per Emergency Ordinance 20-027 New 850 sq. ft. ADU Lan	2018
New	13 6 X 66 Single-wide MH for Temporary Dwelling **30 day extension given 9/30/19 so gutter	2018
New	***01/02/2019 DJL- ext 30 days lil buffer*** New 3271 square foot house including attached ga	2018
New	replacing existing house with new 1800 square foot SFR in same foot print	2018
New	New SFR	2018
New	New manufactured home. **Permit in tube at shop NE corner post**	2018
New	2 story sfr with 1818 sf attached garage and 1768 sf unfinished basement	2018
New	New 2079 sq ft home with attached garage of 572 sq ft and 146 sq ft of covered deck.	2018
New	1616 square foot SFR with attached Garage	2018
New	1979 28 x 70 double-wide Mobile Home To get permit for unpermitted MH placed on parcel i	2018
New	New SFR	2018
New	New double-wide	2018



Accessory Dwelling Units

Index # - File Name: 1.0022 - Single Family Dwellings Data\_Snohomish County.pdf

New	New 44 x54 Single Family Residence existing sfr to be converted to a guest house	2018
New	CASP AFN: 201805180243 Declaration of ownership AFN: 21805180241 Glacier Peak Hazard Di	2018
New	New 27x70 double wide MH	2018
New	New single family residence w/attached garage	2018
New	Two story SFR with attached Garage	2018
New	Two story SFR AFN: 201808060357	2018
New	2018 40 X 70 Triple-wide MH	2018
New	New SFR	2018
New	Expiration date extended 120 days per Emergency Ordinance 20-027 Two story SFR with attach	2018
New	Expiration date extended 120 days per Emergency Ordinance 20-027 01/28/20 esp One time ex	2018
New	Expiration date extended 120 days per Emergency Ordinance 20-027 New triple wide mobile ho	2018
New	Expiration date extended 120 days per Emergency Ordinance 20-027 ***30 day buffer for perm	2018
New	New 3,842 sf SFR with 538 sf attached garage, 1,495 sf covered deck, and 884 sf storage	2018
New	3617 square foot SFR with attached Garage	2018
New	65.5 x 72 single family residence	2018
New	2168 square foot SFR with attached Garage	2018
New	New SFR	2018
New	New 27 x 61 4 mobile home	2018
New	2018 14 X 59 Mobile Home use as a guesthouse	2018
New	New 1 story SFR Landslide Hazard Area PFN 201809070164 CASP PFN 201809070165	2018
New	New SFR	2018
New	New 1807 sq ft SFR with attached garage and covered porch.	2018
New	2136 square foot Duplex with attached Garage	2018
New	EPERMIT Description of work: Attached Garage that is 56x35, and an accessory apartment that i	2018
New	Permit to get final on MH permit 09-101961 MH	2018
New	Expiration date extended 120 days per Emergency Ordinance 20-027 One time one month exte	2018
New	Expiration date extended 120 days per Emergency Ordinance 20-027 New 3 story SFR including	2018
New	New SFR	2018
New	Two story SFR with attached Garage *** Water Use Covenant# 201808300144 ***	2018
New	Expiration date extended 120 days per Emergency Ordinance 20-027 Land Use Binder AFN: 201	2018
New	EPERMIT Description of Work: Development of site to have SFR mobile home. *****Submittal	2019
New	Expiration date extended 120 days per Emergency Ordinance 20-027 EPermit E18-44653 New r	2019
New	2223 square foot SFR with attached Garage Documents are in pro folder 18-126620	2019
New	EPERMIT Description of Work: Single Family Residence	2019
New	Expiration date extended 120 days per Emergency Ordinance 20-027 EPERMIT Description of W	2019
New	Expiration date extended 120 days per Emergency Ordinance 20-027 EPERMIT: New living space	2019
New	Expiration date extended 120 days per Emergency Ordinance 20-027 EPERMIT Description of W	2019
New	Expiration date extended 120 days per Emergency Ordinance 20-027 EPERMIT Description of W	2019
New	Expiration date extended 120 days per Emergency Ordinance 20-027 EPERMIT Description of W	2019
New	Expiration date extended 120 days per Emergency Ordinance 20-027 EPERMIT Description of W	2019
New	Expiration date extended 120 days per Emergency Ordinance 20-027 EPERMIT Description of W	2019
New	Expiration date extended 120 days per Emergency Ordinance 20-027 EPERMIT Description of W	2019
New	EPERMIT Description of Work: Construct single family residence for primary use.	2019
New	Expiration date extended 120 days per Emergency Ordinance 20-027 EPERMIT Description of W	2019
New	EPERMIT Description of Work: Build new single family home	2019
New	Expiration date extended 120 days per Emergency Ordinance 20-027 CASP 201910240186 EPER	2019
New	Expiration date extended 120 days per Emergency Ordinance 20-027 EPERMIT: Replacing single	2019
New	Expiration date extended 120 days per Emergency Ordinance 20-027 EPERMIT Description of W	2019

Accessory Dwelling Units

Index # - File Name: 1.0022 - Single Family Dwellings Data\_Snohomish County.pdf

New	Expiration date extended 120 days per Emergency Ordinance 20-027 Manufactured home: 1990	2019
New	Expiration date extended 120 days per Emergency Ordinance 20-027 EPERMIT Description of W	2019
New	EPERMIT: Description of Work: New SFR- Documents for LDA are located in 18-151312 PRO.	2019
New	EPERMIT E18-44805 Description of Work: New SFR LOT 2 Documents for LDA located in 18-151	2019
New	**1/9/2019 LRR Expired without County approval to use or occupy** Two-story SFR with attache	2019
New	Expiration date extended 120 days per Emergency Ordinance 20-027 EPERMIT Description of W	2019
New	Expiration date extended 120 days per Emergency Ordinance 20-027 EPermit: New SFR Associa	2019
New	2019 27 x 64 Waverly Crest Documents located in 18-125297 PRO	2019
New	26 8 X 62 2007 Festival 4563D Double-wide Mobile Home	2019
New	Expiration date extended 120 days per Emergency Ordinance 20-027 Volcanic Disclosure Notice	2019
New	Expiration date extended 120 days per Emergency Ordinance 20-027 EPERMIT Description of W	2019
New	1838 s.f. rambler w/attached garage	2019
New	Expiration date extended 120 days per Emergency Ordinance 20-027 EPERMIT Description of W	2019
New	*CASP recorded under 201907311057* EPERMIT Description of Work: Removal of existing man	2019
New	Expiration date extended 120 days per Emergency Ordinance 20-027 EPERMIT Description of W	2019
New	EPermit E18-37141 18-37141 1353 s.f. rambler w/attached garage Documents located in 18-1	2019
New	Expiration date extended 120 days per Emergency Ordinance 20-027 EPERMIT: 1,444 sf SFR w/a	2019
New	Expiration date extended 120 days per Emergency Ordinance 20-027 EPERMIT Description of W	2019
New	Expiration date extended 120 days per Emergency Ordinance 20-027 EPERMIT Description of W	2019
New	Airport disclosure AFN: 201903060287 EPERMIT: New 1 story single family home Documents in	2019
New	Expiration date extended 120 days per Emergency Ordinance 20-027 EPERMIT Description of W	2019
New	Expiration date extended 120 days per Emergency Ordinance 20-027 EPERMIT Description of W	2019
New	***09/18/2019 DJL- Waiting on LDA final fees to be paid, RK has been issued waiting to upload	2019
New	Expiration date extended 120 days per Emergency Ordinance 20-027 New single family dwelling	2019
New	EPERMIT E19-00398 Description of Work: new manufactured home	2019
New	Expiration date extended 120 days per Emergency Ordinance 20-027 EPERMIT E18-13920 Descr	2019
New	EPERMIT Description of Work: Building permit for a single family 3620 square foot residence	2019
New	EPERMIT 18-34200: Manufactured home, 2019 double wide - Palm Harbor, St. Andrews (30 x 64	2019
New	2 story sfr w/attached garage	2019
New	Approved basic 16-118177 BP 2015 IRC Plan# 2370 (25# snow load)	2019
New	Expiration date extended 120 days per Emergency Ordinance 20-027 Approved basic 17-105451	2019
New	Expiration date extended 120 days per Emergency Ordinance 20-027 Approved basic 16-118177	2019
New	EPermit E18-42448 993 s.f. residence w/477 s.f. basement & attached garage Documents are	2019
New	Two story SFR with attached Garage Documents are in pro folder 18-127244	2019
New	Expiration date extended 120 days per Emergency Ordinance 20-027 EPERMIT: Single family re:	2019
New	Expiration date extended 120 days per Emergency Ordinance 20-027 EPERMIT Description of W	2019
New	Expiration date extended 120 days per Emergency Ordinance 20-027 EPERMIT Description of W	2019
New	EPERMIT Description of Work: construction of new single family residence on existing develop	2019
New	Expiration date extended 120 days per Emergency Ordinance 20-027 EPERMIT Description of W	2019
New	EPERMIT Description of Work: New construction SFR	2019
New	Expiration date extended 120 days per Emergency Ordinance 20-027 EPERMIT: Replacing existir	2019
New	Expiration date extended 120 days per Emergency Ordinance 20-027 EPERMIT Description of W	2019
New	Expiration date extended 120 days per Emergency Ordinance 20-027 EPERMIT Description of W	2019
New	Expiration date extended 120 days per Emergency Ordinance 20-027 EPERMIT Description of W	2019
New	EPermit E18-47344 Approved basic 16-111714 BP 2015 IRC Plan# 2014 plan 2- st	2019
New	Expiration date extended 120 days per Emergency Ordinance 20-027 Double-wide placed witho	2019
New	New single family residence of 1806 sq ft with attached 691 sq ft garage. *****See 18-12	2019

Accessory Dwelling Units

Index # - File Name: 1.0022 - Single Family Dwellings Data\_Snohomish County.pdf

New	Expiration date extended 120 days per Emergency Ordinance 20-027 EPERMIT Description of W	2019
New	Expiration date extended 120 days per Emergency Ordinance 20-027 EPERMIT Description of W	2019
New	Expiration date extended 120 days per Emergency Ordinance 20-027 EPERMIT Description of W	2019
New	***08/05/2019 DJL- Airport # 201908050568*** EPERMIT Description of Work: CONSTRUCTIO	2019
New	Expiration date extended 120 days per Emergency Ordinance 20-027 Airport recording number#	2019
New	Expiration date extended 120 days per Emergency Ordinance 20-027 E-Permit E18-35115 New 2	2019
New	Expiration date extended 120 days per Emergency Ordinance 20-027 Two story SFR with attach	2019
New	Expiration date extended 120 days per Emergency Ordinance 20-027 EPERMIT Description of W	2019
New	EPERMIT Description of Work: New duplex Airport Influence Disclosure Notice AFN 201904220	2019
New	Expiration date extended 120 days per Emergency Ordinance 20-027 2 story single family reside	2019
New	Expiration date extended 120 days per Emergency Ordinance 20-027 EPermit E18-36492 New 5	2019
New	Expiration date extended 120 days per Emergency Ordinance 20-027 EPERMIT Description of W	2019
New	Expiration date extended 120 days per Emergency Ordinance 20-027 EPERMIT E19-04987 Descr	2019
New	Expiration date extended 120 days per Emergency Ordinance 20-027 EPERMIT Description of W	2019
New	EPERMIT Description of Work: Clearing and Grading for construction of SFR and drainage improv	2019
New	Expiration date extended 120 days per Emergency Ordinance 20-027 EPERMIT: Accessory Dwell	2019
New	EPERMIT Description of Work: Demolition and disposal of older single wide manufactured home	2019
New	Expiration date extended 120 days per Emergency Ordinance 20-027 Two Story SFR with attach	2019
New	Expiration date extended 120 days per Emergency Ordinance 20-027 Land Use Permit Binder- 2	2019
New	Expiration date extended 120 days per Emergency Ordinance 20-027 New two story SFR	2019
New	Expiration date extended 120 days per Emergency Ordinance 20-027 EPERMIT Description of W	2019
New	1801 s.f. rambler w/attached garage Documents located in 18-126846 PRO	2019
New	Expiration date extended 120 days per Emergency Ordinance 20-027 EPERMIT: E18-44500 Raml	2019
New	Expiration date extended 120 days per Emergency Ordinance 20-027 EPERMIT Description of W	2019
New	Expiration date extended 120 days per Emergency Ordinance 20-027 EPERMIT Description of W	2019
New	EPERMIT: Building new 59x55 three bedroom SFR Submittal documents located in 18-125530 P	2019
New	Expiration date extended 120 days per Emergency Ordinance 20-027 EPERMIT Description of W	2019
New	Expiration date extended 120 days per Emergency Ordinance 20-027 Two story SFR with attach	2019
New	Expiration date extended 120 days per Emergency Ordinance 20-027 EPERMIT Description of W	2019
New	Expiration date extended 120 days per Emergency Ordinance 20-027 EPERMIT: Description of W	2019
New	Expiration date extended 120 days per Emergency Ordinance 20-027 EPERMIT: Detached Acces:	2019
New	1507 square foot residence w/1454 s.f. finished basement and attached garage Documents loci	2019
New	Expiration date extended 120 days per Emergency Ordinance 20-027 EPERMIT Description of W	2019
New	Expiration date extended 120 days per Emergency Ordinance 20-027 EPERMIT Description of W	2019
New	Expiration date extended 120 days per Emergency Ordinance 20-027 EPERMIT Description of W	2019
New	Expiration date extended 120 days per Emergency Ordinance 20-027 EPERMIT Description of W	2019
New	New 37x36 SFR Approved Basic 16-115219 BP 2015 IRC Plan# 2165 2-story SFR	2019
New	Expiration date extended 120 days per Emergency Ordinance 20-027 EPERMIT Description of W	2019
New	Declaration of Owner Occupancy AFN: 201903050331 EPermit: Accessory Apartment - 2018 Dc	2019
New	Expiration date extended 120 days per Emergency Ordinance 20-027 2500 sf single family reside	2019
New	Expiration date extended 120 days per Emergency Ordinance 20-027 EPERMIT Description of W	2019
New	EPERMIT Description of Work: Proposed two story single family residence. Associated Permit: 1	2019
New	EPERMIT: Building new 42x36 4 bedroom SFR Submittal documents located in 18-125539 PRO	2019
New	Expiration date extended 120 days per Emergency Ordinance 20-027 Two story SFR with attach	2019
New	Expiration date extended 120 days per Emergency Ordinance 20-027 EPERMIT Description of W	2019
New	2 story sfr w/attached garage Documents located in 18-127019 PRO Permit Revision & SF chang	2019
New	Expiration date extended 120 days per Emergency Ordinance 20-027 EPERMIT Description of W	2019

Accessory Dwelling Units

Index # - File Name: 1.0022 - Single Family Dwellings Data\_Snohomish County.pdf

New	EPERMIT Description of Work: Construct a new duplex on vacant land.	2019
New	Expiration date extended 120 days per Emergency Ordinance 20-027 EPERMIT: New Single Fami	2019
New	Expiration date extended 120 days per Emergency Ordinance 20-027 EPERMIT Description of W	2019
New	EPERMIT: New SFR with attached garage. Associated permit: 18-152040-LDA, 19-101575-AB	2019
New	Expiration date extended 120 days per Emergency Ordinance 20-027 New 2 story SFR	2019
New	Expiration date extended 120 days per Emergency Ordinance 20-027 EPERMIT E19-01290 Descr	2019
New	EPERMIT Description of Work: Single Family Residence Associated Permit: 19-100759-LDA	2019
New	EPERMIT Description of Work: New single family rambler. Associated permit: 19-106576-LDA	2019
New	EPERMIT E18-40761: Building new 4 bedroom 80x68 SFR Submittal documents located in 18-1	2019
New	Expiration date extended 120 days per Emergency Ordinance 20-027 2018 Fleetwood 28 8 X 56	2019
New	Expiration date extended 120 days per Emergency Ordinance 20-027 EPERMIT: New Single Fami	2019
New	Expiration date extended 120 days per Emergency Ordinance 20-027 New 3213 square foot hou	2019
New	Expiration date extended 120 days per Emergency Ordinance 20-027 New 2 story 3226 sq ft res	2019
New	Expiration date extended 120 days per Emergency Ordinance 20-027 EPERMIT Description of W	2019
New	EPERMIT Description of Work: Demolition of existing residence for the construction of a new re	2019
New	Expiration date extended 120 days per Emergency Ordinance 20-027 EPERMIT Description of W	2019
New	Expiration date extended 120 days per Emergency Ordinance 20-027 EPERMIT: Construct new s	2019
New	Expiration date extended 120 days per Emergency Ordinance 20-027 Water use covenant AFN 2	2019
New	Expiration date extended 120 days per Emergency Ordinance 20-027 EPERMIT: New two story S	2019
New	Expiration date extended 120 days per Emergency Ordinance 20-027 build new single family dv	2019
New	Expiration date extended 120 days per Emergency Ordinance 20-027 EPERMIT: 2702 sf sfr w/ at	2019
New	Expiration date extended 120 days per Emergency Ordinance 20-027 EPERMIT Description of W	2019
New	Expiration date extended 120 days per Emergency Ordinance 20-027 EPERMIT: Building new 3 b	2019
New	E permit: Detached accessory apartment Documents located in parent: 18-123792-PRO	2019
New	EPERMIT Description of Work: One single family home	2019
New	EPERMIT Description of Work: Installation of new manufactured home	2019
New	EPERMIT Description of Work: Installation of new manufactured home	2019
New	EPERMIT : New mobile home in a mobile home park.	2019
New	EPERMIT Description of Work: Installation of Manufactured home	2019
New	EPERMIT: Install manufactured home on property	2019
New	EPERMIT Description of Work: Install manufactured home on property. Space/Lot 37 of Country	2019
New	New Accessory Apartment building. Subject to 18-152162-ACUP *****See 18-125531-PRO	2019
New	CASP 201902210123 Water use covenant 201902080327 New two story Single Family Residen	2019
New	EPERMIT Description of Work: Build a new one story structure with a garage and ADU Associat	2019
New	2018 Fleetwood 28 8 Double-wide Mobile Home Document can be found is PRO folder 18-12	2019
New	EPERMIT Description of Work: new double wide mobile home. Associated Permit: 18-122927-L	2019
New	2019 27 x 62 Skyline 1299CT Documents located in 18-125564 PRO	2019
New	New 2 story single family residence Documents located in parent: 18-123932-PRO	2019
New	EPERMIT: Building new 45x63 SFR Consistent with existing CASP AFN 200007190291	2019
New	Expiration date extended 120 days per Emergency Ordinance 20-027 3500 s.f. rambler w/attach	2019
New	Expiration date extended 120 days per Emergency Ordinance 20-027 ***05/06/2019 DJL- Cover	2019
New	Expiration date extended 120 days per Emergency Ordinance 20-027 EPERMIT: New single fami	2019
New	Expiration date extended 120 days per Emergency Ordinance 20-027 ***7/10/2019 DJL- Airpor	2019
New	EPERMIT Description of Work: INSTALL DOUBLE WIDE MOBILE HOME IN PARK	2019
New	Expiration date extended 120 days per Emergency Ordinance 20-027 EPERMIT: New single wide	2019
New	EPERMIT Description of Work: NEW MANUFACTURED HOME	2019
New	EPERMIT: New Mobile Home 2019 Cavco 15 x 30	2019

Accessory Dwelling Units

Index # - File Name: 1.0022 - Single Family Dwellings Data\_Snohomish County.pdf

New	EPERMIT: New Mobile Home 2019 Fleetwood 20 x 42				2019
New	EPERMIT Description of Work: install mobile home in a Mobile Home Park				2019
New	EPERMIT: New Mobile Home 2019 Fleetwood 15 x 44				2019
New	Expiration date extended 120 days per Emergency Ordinance 20-027 ***Airport Disclosure Doc				2019
New	Expiration date extended 120 days per Emergency Ordinance 20-027 EPERMIT Description of W				2019
New	EPERMIT Description of Work: Construction of new cabin (SFR) on undeveloped parcel with nec				2019
New	Expiration date extended 120 days per Emergency Ordinance 20-027 EPERMIT Description of W				2019
New	EPERMIT Description of Work: Construction new SFR				2019
New	Approved basic 16-118182 BP	2015 IRC	Plan# 2972	2-story sfr w	2019
New	Approved Basic 17109022BP	2015 IRC	PLAN# 3019	3019sf two stor	2019
New	Approved basic 16-121633BP	2015 IRC	Plan# 2458	2-story sfr w/attache	2019
New	2 story sfr w/attached garage Documents in 18-125437 PRO				2019
New	Expiration date extended 120 days per Emergency Ordinance 20-027 EPERMIT Description of W				2019
New	EPERMIT Description of Work: Construct New SFR on Acreage ** Associated LDA, 18-118606-L				2019
New	Expiration date extended 120 days per Emergency Ordinance 20-027 EPERMIT Description of W				2019
New	Expiration date extended 120 days per Emergency Ordinance 20-027 EPERMIT Description of W				2019
New	Expiration date extended 120 days per Emergency Ordinance 20-027 EPERMIT Description of W				2019
New	Expiration date extended 120 days per Emergency Ordinance 20-027 AFN 201906130299 New S				2019
New	Expiration date extended 120 days per Emergency Ordinance 20-027 EPERMIT: New one story				2019
New	Expiration date extended 120 days per Emergency Ordinance 20-027 EPERMIT Description of W				2019
New	Expiration date extended 120 days per Emergency Ordinance 20-027 New single family residen				2019
New	Expiration date extended 120 days per Emergency Ordinance 20-027 EPERMIT Description of W				2019
New	Expiration date extended 120 days per Emergency Ordinance 20-027 EPERMIT E18-46970 Descr				2019
New	Expiration date extended 120 days per Emergency Ordinance 20-027 EPERMIT Description of W				2019
New	Expiration date extended 120 days per Emergency Ordinance 20-027 2 story sfr w/finished base				2019
New	Expiration date extended 120 days per Emergency Ordinance 20-027 CASP AFN# 201906260562				2019
New	Expiration date extended 120 days per Emergency Ordinance 20-027 Water Covenant AFN: 201				2019
New	EPERMIT Description of Work: Construct a owner occupied single family residence 18-122889 L				2019
New	Expiration date extended 120 days per Emergency Ordinance 20-027 EPERMIT Description of W				2019
New	EPERMIT: New sfr				2019
New	EPERMIT Description of Work: Single Family Residence, 4-bedroom septic system				2019
New	Expiration date extended 120 days per Emergency Ordinance 20-027 EPERMIT Description of W				2019
New	EPERMIT Description of Work: New single family residence. refer to approved and recorded plat				2019
New	EPERMIT Description of Work: Lot 6 of approved short plat Meadow lake north				2019
New	EPERMIT Description of Work: installation of new manufactured home				2019
New	2 story duplex w/attached garage				2019
New	Approved basic 16-118177 BP	2015 IRC	Plan# 2370	2-story sfr w/	2019
New	Approved basic 16-118186 BP	2015 IRC	Plan# 2060 (25# snow load)		2019
New	Approved basic 17-105451 BP	2015 IRC	Plan# 2477 (38#)	2 story SI	2019
New	Approved basic 16-118186 BP	2015 IRC	Plan# 2060	Rambler w/atta	2019
New	Expiration date extended 120 days per Emergency Ordinance 20-027 New SFR with 18 114319LI				2019
New	Expiration date extended 120 days per Emergency Ordinance 20-027 Approved basic 17-104187				2019
New	Expiration date extended 120 days per Emergency Ordinance 20-027 Approved basic 17-104187				2019
New	Expiration date extended 120 days per Emergency Ordinance 20-027 Approved basic 17-104187				2019
New	Expiration date extended 120 days per Emergency Ordinance 20-027 Approved basic 17-104187				2019
New	Expiration date extended 120 days per Emergency Ordinance 20-027 Approved Basic 18-117075				2019
New	Expiration date extended 120 days per Emergency Ordinance 20-027 Approved Basic 18-117075				2019

Accessory Dwelling Units

Index # - File Name: 1.0022 - Single Family Dwellings Data\_Snohomish County.pdf

New	Expiration date extended 120 days per Emergency Ordinance 20-027 Approved Basic 18-117075	2019
New	Expiration date extended 120 days per Emergency Ordinance 20-027 Approved Basic 18-117075	2019
New	Expiration date extended 120 days per Emergency Ordinance 20-027 Approved Basic 18-111895	2019
New	Expiration date extended 120 days per Emergency Ordinance 20-027 Approved Basic 18-111895	2019
New	EPERMIT: One story single family residence Submittal documents located in 18-127876-PRO	2019
New	EPERMIT Description of Work: Build a new single family residence on lot 7	2019
New	Expiration date extended 120 days per Emergency Ordinance 20-027 Building new 72 x 37 4 SF	2019
New	Expiration date extended 120 days per Emergency Ordinance 20-027 2 story sfr w/attached gara	2019
New	Expiration date extended 120 days per Emergency Ordinance 20-027 2 story sfr w/attached gara	2019
New	Expiration date extended 120 days per Emergency Ordinance 20-027 EPERMIT Description of W	2019
New	2 story sfr w/attached garage Continuation of work on permit 18-101848 RK	2019
New	2 story sfr w/attached garage Continuation of work on permit 18-112458 RK	2019
New	Expiration date extended 120 days per Emergency Ordinance 20-027 2 story sfr w/attached gara	2019
New	EPERMIT Description of Work: New construction of primary residence	2019
New	Expiration date extended 120 days per Emergency Ordinance 20-027 804 sf living space with an	2019
New	Expiration date extended 120 days per Emergency Ordinance 20-027 Single Family Residence: N	2019
New	Expiration date extended 120 days per Emergency Ordinance 20-027 Accessory Apartment (AA)	2019
New	Expiration date extended 120 days per Emergency Ordinance 20-027 Approved basic 19-104836	2019
New	Expiration date extended 120 days per Emergency Ordinance 20-027 Approved basic 19-104836	2019
New	Expiration date extended 120 days per Emergency Ordinance 20-027 Approved basic 19-104836	2019
New	Expiration date extended 120 days per Emergency Ordinance 20-027 Approved basic 19-104836	2019
New	Expiration date extended 120 days per Emergency Ordinance 20-027 Approved basic 19-105950	2019
New	Expiration date extended 120 days per Emergency Ordinance 20-027 Approved basic 19-105950	2019
New	Expiration date extended 120 days per Emergency Ordinance 20-027 Approved basic 19-105950	2019
New	Expiration date extended 120 days per Emergency Ordinance 20-027 Approved basic 19-105950	2019
New	Expiration date extended 120 days per Emergency Ordinance 20-027 EPERMIT Description of W	2019
New	2192 square foot SFR with attached Garage	2019
New	Approved basic 17-103633 BP 2015 IRC Plan 2588-03AB Rambler w/attached gara	2019
New	Expiration date extended 120 days per Emergency Ordinance 20-027 EPERMIT Description of W	2019
New	Approved Basic 18-126634BP 2015 IRC PLAN: 3418-03C 3418sf two st	2019
New	Approved Basic 18-126634BP 2015 IRC PLAN: 3418-03C 3418sf two st	2019
New	Approved basic 17-103633 BP 2015 IRC Plan 2588-03AB Rambler w/attached gara	2019
New	Approved basic 17-103633 BP 2015 IRC Plan 2588-03AB Rambler w/attached gara	2019
New	Approved basic 17-103633 BP 2015 IRC Plan 2588-03AB Rambler w/attached gara	2019
New	Expiration date extended 120 days per Emergency Ordinance 20-027 Approved basic 17-103633	2019
New	Expiration date extended 120 days per Emergency Ordinance 20-027 Approved basic 19-112536	2019
New	Expiration date extended 120 days per Emergency Ordinance 20-027 Approved basic 19-112536	2019
New	Approved Basic 18-126634BP 2015 IRC PLAN: 3418-03C 3418sf two st	2019
New	Approved Basic 18-126633BP 2015 IRC PLAN: 3418-03A 3418sf two story sfr wi	2019
New	EPERMIT Description of Work: construction of new single family residence with necessary utiliti	2019
New	Expiration date extended 120 days per Emergency Ordinance 20-027 Revised to 1976 SHELB 24	2019
New	2 story sfr w/attached garage CASP AFN# 201812130707	2019
New	2 story sfr w/attached garage CASP AFN# 201812130708	2019
New	2702 s.f. rambler w/attached garage CASP AFN# 201812130709	2019
New	Expiration date extended 120 days per Emergency Ordinance 20-027 2 story sfr w/attached gara	2019
New	Expiration date extended 120 days per Emergency Ordinance 20-027 Two story SFR with attach	2019

Accessory Dwelling Units

Index # - File Name: 1.0022 - Single Family Dwellings Data\_Snohomish County.pdf

New	Expiration date extended 120 days per Emergency Ordinance 20-027	EPERMIT Description of W	2019
New	Expiration date extended 120 days per Emergency Ordinance 20-027	EPERMIT Description of W	2019
New	Expiration date extended 120 days per Emergency Ordinance 20-027	EPERMIT Description of W	2019
New	Expiration date extended 120 days per Emergency Ordinance 20-027	EPERMIT Description of W	2019
New	Expiration date extended 120 days per Emergency Ordinance 20-027	EPERMIT E18-46207 Desc	2019
New	Expiration date extended 120 days per Emergency Ordinance 20-027	New two story single famil	2019
New	Expiration date extended 120 days per Emergency Ordinance 20-027	New single family residenc	2019
New	Expiration date extended 120 days per Emergency Ordinance 20-027	EPERMIT Description of W	2019
New	Expiration date extended 120 days per Emergency Ordinance 20-027	EPERMIT Description of W	2019
New	Expiration date extended 120 days per Emergency Ordinance 20-027	Two story SFR with attach	2019
New	Expiration date extended 120 days per Emergency Ordinance 20-027	Approved basic 19-103675	2019
New	Expiration date extended 120 days per Emergency Ordinance 20-027	Approved basic 19-103678	2019
New	Expiration date extended 120 days per Emergency Ordinance 20-027	Approved basic 19-103677	2019
New	Expiration date extended 120 days per Emergency Ordinance 20-027	Approved basic 19-103675	2019
New	Expiration date extended 120 days per Emergency Ordinance 20-027	Approved basic 19-103677	2019
New	Expiration date extended 120 days per Emergency Ordinance 20-027	1836 s.f. rambler w/attach	2019
New	Expiration date extended 120 days per Emergency Ordinance 20-027	Approved basic 16-118797	2019
New	EPERMIT Description of Work: New one story single family residence. Associated Permits: 17-11		2019
New	EPERMIT Description of Work: new SFR Changing foot print of house.		2019
New	EPERMIT Description of Work: Single Family Residence on newly constructed short plat		2019
New	1633 s.f. rambler w/attached garage		2019
New	Approved Basic 18-124947BP	2015 IRC PLAN: Madison C-D Duplex	3218sf two story dt 2019
New	Approved Basic 18-124955BP	2015 IRC PLAN: Chandler C Duplex	3660sf two story dt 2019
New	Approved Basic 18-124947BP	2015 IRC PLAN: Madison C-D Duplex	3218sf two story dt 2019
New	Approved Basic 18-124956BP	2015 IRC PLAN: Chandler D Duplex	3660sf two story 2019
New	Approved Basic 18-124947BP	2015 IRC PLAN: Madison C-D Duplex	3218sf two story dt 2019
New	Approved Basic 18-124947BP	2015 IRC PLAN: Madison C-D Duplex	3218sf two story dt 2019
New	Approved Basic 18-124956BP	2015 IRC PLAN: Chandler D Duplex	3660sf two story 2019
New	EPERMIT Description of Work: SFR new construction for Proposed Lot 1 of pending Final Plat of		2019
New	EPERMIT Description of Work: Single-family new construction		2019
New	Expiration date extended 120 days per Emergency Ordinance 20-027	EPERMIT Description of W	2019
New	Approved Basic 18-125176BP	2015 IRC PLAN: 2614 F (424)	2614sf two story 2019
New	Approved Basic 18-125176BP	2015 IRC PLAN: 2614 F (424)	2614sf two story 2019
New	Approved Basic 18-124994BP	2015 IRC PLAN: 3140 A (434)	3140sf two story SF 2019
New	Approved Basic 18-125155BP	2015 IRC PLAN: 2651A (444)	2651sf two story SFR v 2019
New	Approved Basic 18-126213BP	2015 IRC PLAN: 2566 J (417 J)	2566sf two story SFR w 2019
New	Approved Basic 18-125156BP	2015 IRC PLAN: 2651B (444)	2651sf two story SFR with i 2019
New	Approved Basic 18-124992BP	2015 IRC PLAN: 3029B (433)	3029sf two story SFR w 2019
New	Approved Basic 18-125155BP	2015 IRC PLAN: 2651A (444)	2651sf two story SFR v 2019
New	Approved Basic 18-125176BP	2015 IRC PLAN: 2614 F (424)	2614sf two story 2019
New	Approved Basic 18-125156BP	2015 IRC PLAN: 2651B (444)	2651sf two story SFR with i 2019
New	Approved Basic 18-124994BP	2015 IRC PLAN: 3140 A (434)	3140sf two story SF 2019
New	Approved Basic 18-124993BP	2015 IRC PLAN: 3029C (433)	3029sf two story SF 2019
New	1752 s.f. rambler w/attached garage		2019
New	Rambler style sfr w/attached garage		2019
New	Rambler style sfr w/attached garage		2019
New	EPERMIT Description of Work: Single family home to be constructed on newly developed short p		2019

Accessory Dwelling Units

Index # - File Name: 1.0022 - Single Family Dwellings Data\_Snohomish County.pdf

New	Expiration date extended 120 days per Emergency Ordinance 20-027	EPERMIT	Description of W	2019
New	Expiration date extended 120 days per Emergency Ordinance 20-027	Approved Basic 18-125929		2019
New	Expiration date extended 120 days per Emergency Ordinance 20-027	Approved Basic 18-125929		2019
New	Expiration date extended 120 days per Emergency Ordinance 20-027	Approved Basic 18-125929		2019
New	Expiration date extended 120 days per Emergency Ordinance 20-027	Approved Basic 18-125929		2019
New	Expiration date extended 120 days per Emergency Ordinance 20-027	Approved Basic 18-125929		2019
New	Approved Basic 18-125929 BP	2015 IRC	PLAN: 2646 B 2646sf three story SFR with	2019
New	Expiration date extended 120 days per Emergency Ordinance 20-027	Approved basic 19-112021		2019
New	APPROVED basic 17-105280 BP	2015 IRC	Plan# 2041 Pratt 2-story sfr w/attac	2019
New	Approved basic 17-105279 BP	2015 IRC	Plan# 2124 Concord 2-story sfr w/a	2019
New	APPROVED basic 17-105280 BP	2015 IRC	Plan# 2041 Pratt 2-story sfr w/attac	2019
New	APPROVED basic 17-105280 BP	2015 IRC	Plan# 2041 Pratt 2-story sfr w/attac	2019
New	Approved basic 17-105279 BP	2015 IRC	Plan# 2124 Concord 2-story sfr w/a	2019
New	APPROVED basic 17-105280 BP	2015 IRC	Plan# 2041 Pratt 2-story sfr w/attac	2019
New	Approved basic 17-105279 BP	2015 IRC	Plan# 2124 Concord 2-story sfr w/a	2019
New	APPROVED basic 17-105280 BP	2015 IRC	Plan# 2041 Pratt 2-story sfr w/attac	2019
New	Approved basic 17-105279 BP	2015 IRC	Plan# 2124 Concord 2-story sfr w/a	2019
New	APPROVED basic 17-105280 BP	2015 IRC	Plan# 2041 Pratt 2-story sfr w/attac	2019
New	Approved basic 17-105279 BP	2015 IRC	Plan# 2124 Concord 2-story sfr w/a	2019
New	Approved basic 17-105279 BP	2015 IRC	Plan# 2124 Concord 2-story sfr w/a	2019
New	Approved basic 17-105279 BP	2015 IRC	Plan# 2124 Concord 2-story sfr w/a	2019
New	Approved basic 17-105279 BP	2015 IRC	Plan# 2124 Concord 2-story sfr w/a	2019
New	Approved basic 17-105279 BP	2015 IRC	Plan# 2124 Concord 2-story sfr w/a	2019
New	Approved basic 17-105279 BP	2015 IRC	Plan# 2124 Concord 2-story sfr w/a	2019
New	APPROVED basic 17-105280 BP	2015 IRC	Plan# 2041 Pratt 2-story sfr w/attac	2019
New	EPERMIT E19-00668	Description of Work: new sfr		2019
New	Expiration date extended 120 days per Emergency Ordinance 20-027	Approved basic 19-104565		2019
New	Expiration date extended 120 days per Emergency Ordinance 20-027	Approved Basic 18-122781		2019
New	Approved Basic 18-121904BP	2015 IRC	PLAN: 01GN-B 2425sf two story sfr wi	2019
New	Approved Basic 18-121905BP	2015 IRC	PLAN: 01GN-A 2425sf two story SF	2019
New	Expiration date extended 120 days per Emergency Ordinance 20-027	Approved basic 19-104565		2019
New	Expiration date extended 120 days per Emergency Ordinance 20-027	Approved Basic 18-121903		2019
New	Expiration date extended 120 days per Emergency Ordinance 20-027	Approved Basic 18-122781		2019
New	Expiration date extended 120 days per Emergency Ordinance 20-027	Approved Basic 18-122781		2019
New	Expiration date extended 120 days per Emergency Ordinance 20-027	Approved Basic 18-121905		2019
New	Expiration date extended 120 days per Emergency Ordinance 20-027	Approved Basic 18-122700		2019
New	Approved Basic 18-124981BP	2015 IRC	PLAN: Baker 2 C/D Daylight 3513sf three sto	2019
New	Approved Basic 18-124981BP	2015 IRC	PLAN: Baker 2 C/D Daylight 3513sf three sto	2019
New	Approved Basic 18-124980BP	2015 IRC	PLAN: Trafton 2 C Daylight 3102sf three st	2019
New	Approved Basic 18-124969BP	2015 IRC	PLAN: Trafton 2 D Daylight 3102sf three s	2019
New	Approved Basic 18-124981BP	2015 IRC	PLAN: Baker 2 C/D Daylight 3513sf three sto	2019
New	Approved Basic 18118272 BP	2015 IRC	Plan# Kimball 2 C D 2-story sfr w/at	2019
New	Approved Basic 16-113032 BP	2015 IRC	Plan# Rainier C 2-story sfr w/attached g	2019
New	Approved Basic 17-112478BP	2015 IRC	PLAN: Skagit D 2779 sf two story	2019
New	Approved Basic 18 116039BP	2015 irc	Trafton 2-C 2410 Sq ft 4 bedroom with attached	2019
New	Approved Basic 18118272 BP	2015 IRC	Plan# Kimball 2 C D 2-story sfr w/at	2019
New	Approved Basic 18118272 BP	2015 IRC	Plan# Kimball 2 C D 2-story sfr w/at	2019
New	Approved Basic 16-113032 BP	2015 IRC	Plan# Rainier C 2-story sfr w/attached g	2019
New	Approved Basic: 17-105992 BP	2015 IRC	Plan: Whatcom C/ D 2532 sf 2 story w/fin	2019



Accessory Dwelling Units

Index # - File Name: 1.0022 - Single Family Dwellings Data\_Snohomish County.pdf

New	Approved Basic: 17-105992 BP	2015 IRC	Plan: Whatcom C/ D	2532 sf 2 story w/fin	2019
New	Approved basic 16-113274 BP	2015 IRC	Plan# Mason C	2-story sfr w/attached g	2019
New	Approved basic 16-113275 BP	2015 IRC	Plan# Mason D	2-story sfr w/attached g	2019
New	Approved Basic 16-113032 BP	2015 IRC	Plan# Rainier C	2-story sfr w/attached g	2019
New	Approved Basic 18 116039BP	2015 irc	Trafton 2-C	2410 Sq ft 4 bedroom with attached	2019
New	Approved Basic 18-124969BP	2015 IRC	PLAN: Trafton 2 D Daylight	3102sf three s	2019
New	Approved Basic: 17-105992 BP	2015 IRC	Plan: Whatcom C/ D	2532 sf 2 story w/fin	2019
New	Expiration date extended 120 days per Emergency Ordinance 20-027	EPERMIT:2 story SFR	Asso		2019
New	EPERMIT E18-38340: Single family residential home. Submittal documents located in 18-125809				2019
New	Expiration date extended 120 days per Emergency Ordinance 20-027 ***04/18/2019 DJL- Fees :				2019
New	2 story sfr/w attached garage Submittal documents located in 18-126427 PRO				2019
New	APPROVED basic 17-105280 BP	2015 IRC	Plan# 2041 Pratt	2-story sfr w/attac	2019
New	2019 26 8 X 58 8 Double Wide Mobile Home			Documents can be found in PRO folder 18-1513	2019
New	Approved basic 16-118179 BP	2015 IRC	Plan# 2370 (38#)	2-story	2019
New	Approved basic 16-118175 BP	2015 IRC	Plan# 2541 (38#)	2-story	2019
New	Approved basic 19-118062 BP	2015 IRC	Plan# 1704R -38#	Rambler style sfr w/attached	2019
New	Approved basic 17-105451 BP	2015 IRC	Plan# 2477 (38#)	2 story SI	2019
New	Approved Basic 17-105863 BP	2015 IRC	1704-38#	1704sf daylight rambler \	2019
New	Approved basic 16-118179 BP	2015 IRC	Plan# 2370 (38#)	2-story	2019
New	Approved basic 16-118175 BP	2015 IRC	Plan# 2541 (38#)	2-story	2019
New	Approved basic 16-118179 BP	2015 IRC	Plan# 2370 (38#)	2-story	2019
New	Approved basic 16-118175 BP	2015 IRC	Plan# 2541 (38#)	2-story	2019
New	Approved basic 16-118179 BP	2015 IRC	Plan# 2370 (38#)	2-story	2019
New	Approved basic 17-105451 BP	2015 IRC	Plan# 2477 (38#)	2 story SI	2019
New	Approved Basic 17-106558 BP	2015 IRC	Plan 2537 38#	2 story SFR with Atta	2019
New	Approved basic 16-118175 BP	2015 IRC	Plan# 2541 (38#)	2-story	2019
New	Approved basic 17-105451 BP	2015 IRC	Plan# 2477 (38#)	2 story SI	2019
New	Approved Basic 19-118062 BP	2015 IRC	1704R-38#	1704sf daylight rambler	2019
New	Approved basic 17-105451 BP	2015 IRC	Plan# 2477 (38#)	2 story SI	2019
New	Approved basic 17-105451 BP	2015 IRC	Plan# 2477 (38#)	2 story SI	2019
New	Approved basic 19-111619 BP	2015 IRC	Plan 2481 38#	2481 sf 2-story sfr w/attached 3 ca	2019
New	Approved basic 16-118187 BP	2015 IRC	Plan# 2060 (38#)	Rambler	2019
New	Approved basic 16-118175 BP	2015 IRC	Plan# 2541 (38#)	2-story	2019
New	Approved basic 19-111619 BP	2015 IRC	Plan 2481 38#	2481 sf 2-story sfr w/attached 3 ca	2019
New	Approved basic 16-118187 BP	2015 IRC	Plan# 2060 (38#)	Rambler	2019
New	Expiration date extended 120 days per Emergency Ordinance 20-027	Approved Basic 19-118062			2019
New	Approved basic 17-105451 BP	2015 IRC	Plan# 2477 (38#)	2 story SI	2019
New	Approved basic 16-118179 BP	2015 IRC	Plan# 2370 (38#)	2-story	2019
New	Approved basic 17-105451 BP	2015 IRC	Plan# 2477 (38#)	2 story SI	2019
New	Approved basic 16-118179 BP	2015 IRC	Plan# 2370 (38#)	2-story	2019
New	Approved basic 17-105451 BP	2015 IRC	Plan# 2477 (38#)	2 story SI	2019
New	Expiration date extended 120 days per Emergency Ordinance 20-027	Approved basic 19-114674			2019
New	Expiration date extended 120 days per Emergency Ordinance 20-027	Approved basic 17-105451			2019
New	Approved Basic 19-118062 BP	2015 IRC	1704R-38#	1704sf daylight rambler	2019
New	Approved basic 17-100203 BP	2015 IRC	Plan# 2254 (25# snow load)		2019
New	Approved basic 16-118177 BP	2015 IRC	Plan# 2370 (25# snow load)		2019
New	Approved basic 16-118176 BP	2015 IRC		2-story sfr w/attached garage	2019

Accessory Dwelling Units

Index # - File Name: 1.0022 - Single Family Dwellings Data\_Snohomish County.pdf

New	Approved basic 16-118186 BP	2015 IRC	Plan# 2060 (25# snow load)	2019
New	Approved basic 17-100203 BP	2015 IRC	Plan# 2254 (25# snow load)	2019
New	Approved basic 16-118186 BP	2015 IRC	Plan# 2060 (25# snow load)	2019
New	Expiration date extended 120 days per Emergency Ordinance 20-027 Approved Basic 18118272			2019
New	Approved Basic 18 116043BP	2015 irc	Trafton 2-D 2410 Sq ft 4 bedroom with attached	2019
New	Approved Basic 18 116039BP	2015 irc	Trafton 2-C 2410 Sq ft 4 bedroom with attached	2019
New	Approved Basic 16-113032 BP	2015 IRC	Plan# Rainier C 2-story sfr w/attached g	2019
New	Approved Basic 17-118650 BP	2015 IRC	PLAN: 2431 AB 2431sf three story S	2019
New	Approved Basic 18-120929BP	2015 IRC	PLAN: 2418ABC v 2 2418sf three story	2019
New	Approved basic 19-101581 BP	2015 IRC	Plan# 2431 ABC 2015 IRC v2 3-story sfr w	2019
New	Approved Basic 17-119362 BP	2015 IRC	PLAN: 2175 AB 2015 2175sf three story SFR	2019
New	Approved basic 18-151577 BP	2015 IRC	Plan# 2518 ABC 2015 V2 3-story sfr	2019
New	Approved Basic 18-120929BP	2015 IRC	PLAN: 2418ABC v 2 2418sf three story	2019
New	Approved basic 18-151577 BP	2015 IRC	Plan# 2518 ABC 2015 V2 3-story sfr	2019
New	Approved Basic 18-120927BP	IRC: 2015	PLAN: 2210EF 2210sf three story SFR wit	2019
New	Approved Basic 18-120927BP	IRC: 2015	PLAN: 2210EF 2210sf three story SFR wit	2019
New	Approved Basic 17-118650 BP	2015 IRC	PLAN: 2431 AB 2431sf three story S	2019
New	EPERMIT Description of Work: Proposed SFR			2019
New	Approved Basic 18-118172BP	2015 IRC	3293 sq.ft. 2 story 6 bedroom SFR with atta	2019
New	ON HOLD FOR MITIGATION PAYMNET OF \$273.00 Approved Basic 18-118171BP	2015 IRC		2019
New	Approved Basic 18 116043BP	2015 irc	Trafton 2-D 2410 Sq ft 4 bedroom with attached	2019
New	Approved Basic 18118272 BP	2015 IRC	Plan# Kimball 2 C D 2-story sfr w/at	2019
New	Approved basic 16-113033 BP	2015 IRC	Plan# Rainier D 2-story sfr w/attached g	2019
New	Approved Basic 16-113032 BP	2015 IRC	Plan# Rainier C 2-story sfr w/attached g	2019
New	Approved Basic 18118272 BP	2015 IRC	Plan# Kimball 2 C D 2-story sfr w/at	2019
New	Approved basic 16-113033 BP	2015 IRC	Plan# Rainier D 2-story sfr w/attached g	2019
New	Approved Basic 18118272 BP	2015 IRC	Plan# Kimball 2 C D 2-story sfr w/at	2019
New	Approved Basic 18118272 BP	2015 IRC	Plan# Kimball 2 C D 2-story sfr w/at	2019
New	Approved Basic 18 116039BP	2015 irc	Trafton 2-C 2410 Sq ft 4 bedroom with attached	2019
New	Approved basic 16-113033 BP	2015 IRC	Plan# Rainier D 2-story sfr w/attached g	2019
New	Approved Basic 18 116043BP	2015 irc	Trafton 2-D 2410 Sq ft 4 bedroom with attached	2019
New	Approved Basic 18118272 BP	2015 IRC	Plan# Kimball 2 C D 2-story sfr w/at	2019
New	Approved Basic 16-113032 BP	2015 IRC	Plan# Rainier C 2-story sfr w/attached g	2019
New	Expiration date extended 120 days per Emergency Ordinance 20-027 Approved Basic 18-121903			2019
New	Expiration date extended 120 days per Emergency Ordinance 20-027 Approved Basic 18-122699			2019
New	Expiration date extended 120 days per Emergency Ordinance 20-027 ***04/17/2019 DJL- Uploa			2019
New	Expiration date extended 120 days per Emergency Ordinance 20-027 ***04/17/2019 DJL- Uploa			2019
New	Expiration date extended 120 days per Emergency Ordinance 20-027 Approved Basic 18-12278			2019
New	Expiration date extended 120 days per Emergency Ordinance 20-027 Approved Basic 18-12190			2019
New	Expiration date extended 120 days per Emergency Ordinance 20-027 ***04/17/2019 DJL- Uploa			2019
New	Approved Basic 18-127242BP	2015 IRC	PLAN: 04GN-A 2725 sf two story sfr with	2019
New	Approved Basic 18-121903BP	2015 IRC	PLAN: 01GN-C 2425sf two story SFR v	2019
New	Approved Basic 18-121904BP	2015 IRC	PLAN: 01GN-B 2425sf two story sfr wi	2019
New	Approved Basic 18-121905BP	2015 IRC	PLAN: 01GN-A 2425sf two story SF	2019
New	Approved Basic 18-122184BP	2015 IRC	PLAN: 02GN-B 2582sf two story SFR with ;	2019
New	Approved Basic 18-121903BP	2015 IRC	PLAN: 01GN-C 2425sf two story SFR v	2019
New	Expiration date extended 120 days per Emergency Ordinance 20-027 Approved Basic 18-122183			2019

Accessory Dwelling Units

Index # - File Name: 1.0022 - Single Family Dwellings Data\_Snohomish County.pdf

New	Expiration date extended 120 days per Emergency Ordinance 20-027 Approved Basic 18-122185				2019
New	Expiration date extended 120 days per Emergency Ordinance 20-027 Approved basic 19-102508				2019
New	Expiration date extended 120 days per Emergency Ordinance 20-027 Approved Basic 18-122183				2019
New	Expiration date extended 120 days per Emergency Ordinance 20-027 Approved Basic 19-102513				2019
New	Expiration date extended 120 days per Emergency Ordinance 20-027 Approved Basic 18-122184				2019
New	EPERMIT Description of Work: New SFR Construction Grove North, Bothell				2019
New	EPERMIT Description of Work: New SFR Construction Grove North, Bothell				2019
New	EPERMIT Description of Work: New SFR Construction Grove North, Bothell				2019
New	EPERMIT Description of Work: New CFR Construction Grove North, Bothell				2019
New	Expiration date extended 120 days per Emergency Ordinance 20-027 EPERMIT Description of W				2019
New	Approved Basic 18-117383BP	2015 IRC	PLAN: 1942A	1942sf Two story SFR	2019
New	Approved Basic 18-117381BP	2015 IRC	PLAN: 1942 B/C	1942sf two stor	2019
New	Approved Basic 18-117381BP	2015 IRC	PLAN: 1942 B/C	1942sf two stor	2019
New	Approved Basic 18-117383BP	2015 IRC	PLAN: 1942A	1942sf Two story SFR	2019
New	Approved Basic 18-117381BP	2015 IRC	PLAN: 1942 B/C	1942sf two stor	2019
New	Approved Basic 18-117381BP	2015 IRC	PLAN: 1942 B/C	1942sf two stor	2019
New	Approved Basic 18-117381BP	2015 IRC	PLAN: 1942 B/C	1942sf two stor	2019
New	Approved Basic 18-117383BP	2015 IRC	PLAN: 1942A	1942sf Two story SFR	2019
New	Approved Basic 18-117381BP	2015 IRC	PLAN: 1942 B/C	1942sf two stor	2019
New	Approved Basic 17-112478BP	2015 IRC	PLAN: Skagit D	2779 sf two story	2019
New	Approved Basic 18-117511BP	2015 IRC	PLAN: Olympic C/D	2980sf two story SFF	2019
New	Approved Basic 17-112464 BP	2015 IRC	PLAN: Skagit C	2779 sf two story !	2019
New	Approved basic 16-113278 BP	2015 IRC	Plan# Chelan II D	2-story sfr w/attached gara	2019
New	Approved Basic 17-112464 BP	2015 IRC	PLAN: Skagit C	2779 sf two story !	2019
New	Approved Basic 18118272 BP	2015 IRC	Plan# Kimball 2 C D	2-story sfr w/at	2019
New	Expiration date extended 120 days per Emergency Ordinance 20-027 Approved Basic 17-112478				2019
New	Approved Basic 18-117511BP	2015 IRC	PLAN: Olympic C/D	2980sf two story SFF	2019
New	Approved Basic 18118272 BP	2015 IRC	Plan# Kimball 2 C D	2-story sfr w/at	2019
New	Approved Basic 17-112464 BP	2015 IRC	PLAN: Skagit C	2779 sf two story !	2019
New	Approved Basic 18118272 BP	2015 IRC	Plan# Kimball 2 C D	2-story sfr w/at	2019
New	Approved Basic 17-119362 BP	2015 IRC	PLAN: 2175 AB 2015	2175sf three story SFR	2019
New	Approved Basic 18-120929BP	2015 IRC	PLAN: 2418ABC v 2	2418sf three story	2019
New	Approved Basic 17-118650 BP	2015 IRC	PLAN: 2431 AB	2431sf three story S	2019
New	Approved Basic 17-119362 BP	2015 IRC	PLAN: 2175 AB 2015	2175sf three story SFR	2019
New	Approved Basic 17-118650 BP	2015 IRC	PLAN: 2431 AB	2431sf three story S	2019
New	Approved Basic 18-120929BP	2015 IRC	PLAN: 2418ABC v 2	2418sf three story	2019
New	Approved Basic 17-119362 BP	2015 IRC	PLAN: 2175 AB 2015	2175sf three story SFR	2019
New	Approved Basic 17-118650 BP	2015 IRC	PLAN: 2431 AB	2431sf three story S	2019
New	Approved Basic 18-120929BP	2015 IRC	PLAN: 2418ABC v 2	2418sf three story	2019
New	Approved Basic 17-118650 BP	2015 IRC	PLAN: 2431 AB	2431sf three story S	2019
New	Approved Basic 17-119362 BP	2015 IRC	PLAN: 2175 AB 2015	2175sf three story SFR	2019
New	Approved Basic 18-120929BP	2015 IRC	PLAN: 2418ABC v 2	2418sf three story	2019
New	Approved Basic 17-118650 BP	2015 IRC	PLAN: 2431 AB	2431sf three story S	2019
New	Approved basic 19-103422 BP	2015 IRC	Plan 2175-02ABC	3-story SFR w/attached garage	2019
New	Approved basic 18-151577 BP	2015 IRC	Plan# 2518 ABC 2015 V2	3-story sfr	2019
New	Approved Basic 18-120929BP	2015 IRC	PLAN: 2418ABC v 2	2418sf three story	2019
New	Approved Basic 17-119362 BP	2015 IRC	PLAN: 2175 AB 2015	2175sf three story SFR	2019
New	Approved Basic 17-118650 BP	2015 IRC	PLAN: 2431 AB	2431sf three story S	2019

Accessory Dwelling Units

Index # - File Name: 1.0022 - Single Family Dwellings Data\_Snohomish County.pdf

New	Approved Basic 18-120929BP	2015 IRC	PLAN: 2418ABC v 2	2418sf three story	2019
New	Approved Basic 17-118650 BP	2015 IRC	PLAN: 2431 AB	2431sf three story S	2019
New	Approved Basic 18117479BP	2015IRC	3284	4 Bedroom SFR with attached garage	2019
New	EPERMIT Description of Work: NEW SFR				2019
New	Expiration date extended 120 days per Emergency Ordinance 20-027 Approved basic 16-120708				2019
New	Expiration date extended 120 days per Emergency Ordinance 20-027 Recording for Practice For				2019
New	Approved Basic 18100014BP	2015 IRC	3634	3634 sq ft 2 story with attached garage. PEF	2019
New	Approved Basic 18-122329BP	2015 IRC	PLAN: 3201 30#Snow Load	3201sf SFR ramb	2019
New	Approved Basic 17-116665 BP	2015 IRC	PLAN # 3745	Two story SFR with attached g	2019
New	Approved basic 16-120708 BP	2015 IRC	Plan# 3484	2-story sfr w/attache	2019
New	Approved Basic 18-122329BP	2015 IRC	PLAN: 3201 30#Snow Load	3201sf SFR ramb	2019
New	Approved basic 19-103998 BP	2015 IRC	Plan 2872	2872sf rambler w/attached garage	2019
New	Approved basic 16-114079 BP	2015 IRC	Plan# 2766	2766 s.f. rambler w/att	2019
New	Approved Basic 18-120730 BP	2015 IRC	3044	3 Bedroom SFR with 3 car garage	2019
New	Approved Basic 18-100014BP	2015 IRC	3634	3634 sq ft 2 story with attached garage.	2019
New	Approved Basic 18-122329BP	2015 IRC	PLAN: 3201 30#Snow Load	3201sf SFR ramb	2019
New	Expiration date extended 120 days per Emergency Ordinance 20-027 New double-wide				2019
New	Expiration date extended 120 days per Emergency Ordinance 20-027 AFN: 201902150348				2019
New	EPERMIT E18-36124: New 2-story house with attached garage ****See 18-125045-PRO****				2019
New	Approved Basic 17-118650 BP	2015 IRC	PLAN: 2431 AB	2431sf three story S	2019
New	Approved Basic 17-119362 BP	2015 IRC	PLAN: 2175 AB 2015	2175sf three story SFR	2019
New	Approved Basic 18-120927BP	IRC: 2015	PLAN: 2210EF	2210sf three story SFR wit	2019
New	Approved Basic 17-119362 BP	2015 IRC	PLAN: 2175 AB 2015	2175sf three story SFR	2019
New	Approved Basic 18-120927BP	IRC: 2015	PLAN: 2210EF	2210sf three story SFR wit	2019
New	Approved Basic 18-120929BP	2015 IRC	PLAN: 2418ABC v 2	2418sf three story	2019
New	Approved Basic 17-118650 BP	2015 IRC	PLAN: 2431 AB	2431sf three story S	2019
New	Approved Basic 17-118650 BP	2015 IRC	PLAN: 2431 AB	2431sf three story S	2019
New	Approved Basic 18-120929BP	2015 IRC	PLAN: 2418ABC v 2	2418sf three story	2019
New	Approved Basic 17-119362 BP	2015 IRC	PLAN: 2175 AB 2015	2175sf three story SFR	2019
New	Approved Basic 18-120929BP	2015 IRC	PLAN: 2418ABC v 2	2418sf three story	2019
New	Approved Basic 17-118650 BP	2015 IRC	PLAN: 2431 AB	2431sf three story S	2019
New	Approved Basic 17-119362 BP	2015 IRC	PLAN: 2175 AB 2015	2175sf three story SFR	2019
New	Approved Basic 17-118650 BP	2015 IRC	PLAN: 2431 AB	2431sf three story S	2019
New	Approved Basic 17-118650 BP	2015 IRC	PLAN: 2431 AB	2431sf three story S	2019
New	Approved Basic 18-120929BP	2015 IRC	PLAN: 2418ABC v 2	2418sf three story	2019
New	Approved Basic 18-120927BP	IRC: 2015	PLAN: 2210EF	2210sf three story SFR wit	2019
New	Approved Basic 18-120927BP	IRC: 2015	PLAN: 2210EF	2210sf three story SFR wit	2019
New	Approved Basic 18-120929BP	2015 IRC	PLAN: 2418ABC v 2	2418sf three story	2019
New	Approved Basic 17-118650 BP	2015 IRC	PLAN: 2431 AB	2431sf three story S	2019
New	Approved Basic 17-119362 BP	2015 IRC	PLAN: 2175 AB 2015	2175sf three story SFR	2019
New	Approved Basic 17-118650 BP	2015 IRC	PLAN: 2431 AB	2431sf three story S	2019
New	Approved Basic 17-119362 BP	2015 IRC	PLAN: 2175 AB 2015	2175sf three story SFR	2019
New	Expiration date extended 120 days per Emergency Ordinance 20-027 Approved Basic 18-120927				2019
New	EPERMIT Description of Work: Construct single family residence on lot short plat ready for deve				2019
New	EPERMIT Description of Work: Single Family Residence on newly constructed short plat				2019
New	EPERMIT Description of Work: Single Family Residence in Subdivision				2019
New	EPERMIT: New construction SFR				2019

Accessory Dwelling Units

Index # - File Name: 1.0022 - Single Family Dwellings Data\_Snohomish County.pdf

New	EPERMIT Description of Work: Single Family Residence in Subdivision				2019
New	EPERMIT Description of Work: Single Family Residence in Subdivision				2019
New	Approved Basic 17-119362 BP	2015 IRC	PLAN: 2175 AB 2015	2175sf three story SFR	2019
New	Approved Basic 18-122954BP	2015 IRC	PLAN: 2582A	2582sf three story SFR \	2019
New	Approved Basic 18-122955 BP	2015 IRC	PLAN: 2582B	2582sf three story SFR with	2019
New	Approved Basic 18-122956BP	2015 IRC	PLAN: 2582C	2582sf three story SFR with	2019
New	Approved Basic 18-122960BP	2015 IRC	PLAN: 2497B	2497sf three story SFR with	2019
New	Approved Basic 18-122971BP	2015 IRC	PLAN: 2581B	2581sf three story SFR with at	2019
New	Approved Basic 18-122961BP	2015 IRC	PLAN: 2581 A	2581sf three story SFR \	2019
New	Approved Basic 18-124183BP	2015 IRC	PLAN: 1977B	1977sf two story SFR with a	2019
New	Approved Basic 18-123945BP	2015 IRC	PLAN: 1977A	1977sf two story SFR wi	2019
New	Approved Basic 18-122958BP	2015 IRC	PLAN: 2525 B	2525sf two story SFR with attache	2019
New	Expiration date extended 120 days per Emergency Ordinance 20-027 Water Use Covenant				2019
New	Approved basic 16-118177 BP	2015 IRC		Plan# 2370 (25# snow load)	2019
New	Expiration date extended 120 days per Emergency Ordinance 20-027 Approved Basic 18-12295				2019
New	Expiration date extended 120 days per Emergency Ordinance 20-027 EPERMIT Description of W				2019
New	Approved Basic 18-122972BP	2015 IRC	PLAN: 2684B	2684sf three story SFR with at	2019
New	Approved Basic 18-122959BP	2015 IRC	PLAN: 2497A	2497sf three story SFR w	2019
New	Approved Basic 18-122964 BP	2015 IRC	PLAN: 2684A	2684 sf three story SFR with	2019
New	Approved Basic 18-122960BP	2015 IRC	PLAN: 2497B	2497sf three story SFR with	2019
New	Approved Basic 18-122972BP	2015 IRC	PLAN: 2684B	2684sf three story SFR with at	2019
New	Expiration date extended 120 days per Emergency Ordinance 20-027 Approved Basic 18-122959				2019
New	Expiration date extended 120 days per Emergency Ordinance 20-027 EPERMIT Description of W				2019
New	Expiration date extended 120 days per Emergency Ordinance 20-027 EPERMIT Description of W				2019
New	EPERMIT: New single family residence.				2019
New	EPERMIT Description of Work: SFR New 2 story 2547 sq ft residence with attached garage.				2019
New	Approved basic 17-105451 BP	2015 IRC		Plan# 2477 (38#) 2 story SI	2019
New	Approved basic 16-118185 BP	2015 IRC		Plan# 2537 2-story sfr w/	2019
New	Approved basic 16-118177 BP	2015 IRC		Plan# 2370 (25# snow load)	2019
New	Approved basic 16-118186 BP	2015 IRC		Plan# 2060 (25# snow load)	2019
New	Approved basic 16-118176 BP	2015 IRC		Plan# 2541 2-story sfr w	2019
New	Approved basic 17-105451 BP	2015 IRC		Plan# 2477 (38#) 2 story SI	2019
New	New 2835 sq ft 2 story SFR with attached 769 sq ft garage and covered porches. *****				2019
New	Expiration date extended 120 days per Emergency Ordinance 20-027 2 story sfr w/attached gara				2019
New	Expiration date extended 120 days per Emergency Ordinance 20-027 EPERMIT Description of W				2019
New	Expiration date extended 120 days per Emergency Ordinance 20-027 Approved Basic 17-118293				2019
New	Expiration date extended 120 days per Emergency Ordinance 20-027 Approved Basic 17-118293				2019
New	Expiration date extended 120 days per Emergency Ordinance 20-027 Approved Basic 17-118293				2019
New	Approved Basic 17-118293 BP	2015 IRC	PLAN: 2747	2747 sf two story single family	2019
New	EPERMIT Description of Work: Construction of new SFR.				2019
New	Approved Basic 18-117490BP	2015 IRC	1858	3 story 3 bedroom SFR with attached g	2019
New	Approved Basic 18-117490BP	2015 IRC	1858	3 story 3 bedroom SFR with attached g	2019
New	Approved Basic 18-117490BP	2015 IRC	1858	3 story 3 bedroom SFR with attached g	2019
New	Approved Basic 18-117490BP	2015 IRC	1858	3 story 3 bedroom SFR with attached	2019
New	Approved Basic 18-117385BP	2015 IRC	PLAN: 1742	1742sf Three Story SFR with	2019
New	Approved Basic 18-117385BP	2015 IRC	PLAN: 1742	1742sf Three Story SFR with	2019
New	EPERMIT: 3012 square foot house				2019

Accessory Dwelling Units

Index # - File Name: 1.0022 - Single Family Dwellings Data\_Snohomish County.pdf

New	Expiration date extended 120 days per Emergency Ordinance 20-027	EPERMIT E18-33472	Desc	2019
New	Expiration date extended 120 days per Emergency Ordinance 20-027	EPERMIT	Description of W	2019
New	Expiration date extended 120 days per Emergency Ordinance 20-027	EPERMIT	Description of W	2019
New	Expiration date extended 120 days per Emergency Ordinance 20-027	EPERMIT	Description of W	2019
New	CASP 201905300383 1999 27 x 44 Fleetwood Double-wide Manufactured Home	Tax Account #:		2019
New	Expiration date extended 120 days per Emergency Ordinance 20-027	Two story SFR		2019
New	Expiration date extended 120 days per Emergency Ordinance 20-027	EPERMIT: Proposed 2 stor		2019
New	Expiration date extended 120 days per Emergency Ordinance 20-027	2 story sfr w/attached gara		2019
New	Approved Basic 18-122360BP	2015 IRC	PLAN: 3745-30#Snow load 3745sf two story	2019
New	Expiration date extended 120 days per Emergency Ordinance 20-027	Approved Basic 18-12591:		2019
New	Approved basic 17-100203 BP	2015 IRC	Plan# 2254 (25# snow load)	2019
New	Expiration date extended 120 days per Emergency Ordinance 20-027	EPERMIT	Description of W	2019
New	Expiration date extended 120 days per Emergency Ordinance 20-027	EPERMIT E19-04624	Descr	2019
New	Expiration date extended 120 days per Emergency Ordinance 20-027	EPERMIT: Construction of		2019
New	Airport Influence Area Disclosure Notice AFN: 201902210221	New 2 story 3656 sq ft house with		2019
New	Expiration date extended 120 days per Emergency Ordinance 20-027	**ACCESS off 116th from 1		2019
New	EPERMIT E18-29410: Approved Basic 18-122140 BP	2015 IBC	3-story home \	2019
New	Expiration date extended 120 days per Emergency Ordinance 20-027	New 2-story 3365 sq ft hou		2019
New	New double-wide mobile. Glacier Peak Volcanic Hazard Area Disclosure Notice AFN# 20181015			2019
New	Expiration date extended 120 days per Emergency Ordinance 20-027	EPERMIT	Description of W	2019
New	Expiration date extended 120 days per Emergency Ordinance 20-027	New 2 story 2649 sq ft hou		2019
New	Expiration date extended 120 days per Emergency Ordinance 20-027	EPERMIT	Description of W	2019
New	Approved Basic 18-126212BP	2015 IRC	PLAN: 3634 35#SnowLoad 3634sf daylight 2	2019
New	Approved Basic 18-126650BP	2015 IRC	3286sf two story SFR with attached garage	2019
New	Expiration date extended 120 days per Emergency Ordinance 20-027	Approved basic 16-120708		2019
New	Approved Basic 18-126650BP	2015 IRC	3286 sf two story SFR with attached garage	2019
New	EPERMIT Description of Work: New Single Family Home, 4 bedrooms, 2 bathrooms			2019
New	Approved Basic 17-107067 BP	2015 IRC	2 story sfr with attached garage	2019
New	Approved Basic 17 114855BP	2015 IRC	Plan 2353AB 2353 Sq Ft Single Family Re:	2019
New	Approved Basic 17-107158 BP	2015 IRC	Plan 2273D 2 story SFR with atl	2019
New	Approved Basic 17-111208 BP	2015 IRC	PLAN: Dayton II D 2084sf two story	2019
New	Approved basic 16-116039 BP	2015 IRC	Plan# Hazelwood D 2-story sfr w/i	2019
New	Approved basic 16-118797 BP	2015 IRC	Plan# 2813 2-story sfr w/attache	2019
New	Approved Basic 17-107067 BP	2015 IRC	Plan 2101 A/B 2 story sfr with attach	2019
New	Approved Basic 17-107067 BP	2015 IRC	Plan 2101 A/B 2 story sfr with attach	2019
New	Approved Basic 17-107067 BP	2015 IRC	Plan 2101 A/B 2 story sfr with attach	2019
New	Approved Basic 17-107067 BP	2015 IRC	Plan 2101 A/B 2 story sfr with attach	2019
New	Approved basic 18-151505 BP	2015 IRC	Plan# 2337 AB 3-story sfr w/attached gara	2019
New	Expiration date extended 120 days per Emergency Ordinance 20-027	EPERMIT E18-34976	Descr	2019
New	Expiration date extended 120 days per Emergency Ordinance 20-027	EPERMIT	Description of W	2019
New	EPERMIT Description of Work: Construct New SFR (Lot 42) in Glenmore Division 2.			2019
New	Expiration date extended 120 days per Emergency Ordinance 20-027	EPERMIT	Description of W	2019
New	Expiration date extended 120 days per Emergency Ordinance 20-027	EPERMIT	Description of W	2019
New	Expiration date extended 120 days per Emergency Ordinance 20-027	EPERMIT	Description of W	2019
New	Expiration date extended 120 days per Emergency Ordinance 20-027	EPERMIT: Minimal interior		2019
New	Approved Basic 17-119177BP	2015 IRC	PLAN#2566 THE ORCHID Elev A 2566sf two st	2019
New	Approved Basic 17-119178BP	2015 IRC	PLAN:#2566 ORCHID Elev B. 2566sf two story S	2019

Accessory Dwelling Units

Index # - File Name: 1.0022 - Single Family Dwellings Data\_Snohomish County.pdf

New	Approved Basic 17-119177BP	2015 IRC	PLAN#2566 THE ORCHID Elev A	2566sf two st	2019
New	Approved Basic 17-119181BP	2015 IRC	3195 Willow ELEV A	3,195 sq. ft. sfr	2019
New	Approved Basic 17-119170 BP	2015 IRC	plan 3195 Willow ELEV B	3,19	2019
New	Approved Basic 17-119179BP	2015 IRC	PLAN#2822 LAUREL Elev A	2822sf two story	2019
New	Approved Basic 17-119181BP	2015 IRC	3195 Willow ELEV A	3,195 sq. ft. sfr	2019
New	Expiration date extended 120 days per Emergency Ordinance 20-027		1344 s.f. detached garage		2019
New	Expiration date extended 120 days per Emergency Ordinance 20-027		EPERMIT Description of W		2019
New	Expiration date extended 120 days per Emergency Ordinance 20-027		EPERMIT Description of W		2019
New	Expiration date extended 120 days per Emergency Ordinance 20-027		EPERMIT Description of W		2019
New	Expiration date extended 120 days per Emergency Ordinance 20-027		EPERMIT Description of W		2019
New	Expiration date extended 120 days per Emergency Ordinance 20-027		EPERMIT Description of W		2019
New	Expiration date extended 120 days per Emergency Ordinance 20-027		EPERMIT Description of W		2019
New	Expiration date extended 120 days per Emergency Ordinance 20-027		EPERMIT Description of W		2019
New	Expiration date extended 120 days per Emergency Ordinance 20-027		EPERMIT Description of W		2019
New	Expiration date extended 120 days per Emergency Ordinance 20-027		EPERMIT Description of Work: Construct new SFR (Lot 11) in Glenmore Division 2.		2019
New	Expiration date extended 120 days per Emergency Ordinance 20-027		EPERMIT Description of W		2019
New	Expiration date extended 120 days per Emergency Ordinance 20-027		EPERMIT Description of Work: Construct new SFR in Glenmore.		2019
New	Expiration date extended 120 days per Emergency Ordinance 20-027		EPERMIT Description of Work: Construct new SFR in Glenmore.		2019
New	Expiration date extended 120 days per Emergency Ordinance 20-027		EPERMIT Description of Work: Construct new SFR (Lot 15) at Glenmore Div. 2		2019
New	Expiration date extended 120 days per Emergency Ordinance 20-027		EPERMIT Description of Work: Construct New SFR in Glenmore Phase 2		2019
New	Expiration date extended 120 days per Emergency Ordinance 20-027		EPERMIT Description of Work: Construct new SFR (Lot 17) in Glenmore Division 2.		2019
New	Expiration date extended 120 days per Emergency Ordinance 20-027		EPERMIT Description of Work: Construct new SFR in Glenmore Phase 2		2019
New	Expiration date extended 120 days per Emergency Ordinance 20-027		EPERMIT Description of Work: Construct new SFR in Glenmore Phase 2		2019
New	Expiration date extended 120 days per Emergency Ordinance 20-027		EPERMIT Description of Work: Construct new SFR in Glenmore Phase 2.		2019
New	Expiration date extended 120 days per Emergency Ordinance 20-027		EPERMIT Description of Work: Construct new SFR - Glenmore phase 2		2019
New	Expiration date extended 120 days per Emergency Ordinance 20-027		EPERMIT Description of Work: Construct New SFR (Lot 22) in Glenmore Phase 2.		2019
New	Expiration date extended 120 days per Emergency Ordinance 20-027		EPERMIT Description of Work: Lot 23 of Glenmore Div 2 -- Construct new SFR with ramp access.		2019
New	Expiration date extended 120 days per Emergency Ordinance 20-027		EPERMIT Description of Work: Construct new SFR (Lot 24) in Glenmore Division 2.		2019
New	Expiration date extended 120 days per Emergency Ordinance 20-027		EPERMIT: 4078 sf SFR w/attached garage		2019
New	Expiration date extended 120 days per Emergency Ordinance 20-027		EPERMIT Description of Work: Construct new SFR at Glenmore.		2019
New	Expiration date extended 120 days per Emergency Ordinance 20-027		EPERMIT Description of Work: Construct new SFR (Lot 27) in Glenmore Division 2.		2019
New	Expiration date extended 120 days per Emergency Ordinance 20-027		EPERMIT Description of Work: Construct new SFR. REQUIRE RECEIPT FROM GRANITE FALLS \$75		2019
New	Expiration date extended 120 days per Emergency Ordinance 20-027		EPERMIT Description of W		2019
New	Expiration date extended 120 days per Emergency Ordinance 20-027		EPERMIT Description of Work: Construct new SFR on GM 30.		2019
New	Approved basic 16-116037 BP	2015 IRC	Plan# Hazelwood C	2-story sfr w/a	2019
New	Approved Basic 17-111208 BP	2015 IRC	PLAN: Dayton II D	2084sf two story	2019
New	Approved Basic 18 116039BP	2015 irc	Trafton 2-C	2410 Sq ft 4 bedroom with attached	2019
New	Approved basic 16-116039 BP	2015 IRC	Plan# Hazelwood D	2-story sfr w/a	2019
New	Approved Basic 18 116043BP	2015 irc	Trafton 2-D	2410 Sq ft 4 bedroom with attached	2019
New	Approved Basic 17-107523 BP	2015 IRC	Plan Granite C	2 story sfr with atta	2019
New	Expiration date extended 120 days per Emergency Ordinance 20-027		Approved Basic 18 116043		2019
New	Expiration date extended 120 days per Emergency Ordinance 20-027		Approved basic 16-116039		2019
New	Expiration date extended 120 days per Emergency Ordinance 20-027		Approved basic 16-116037		2019
New	Expiration date extended 120 days per Emergency Ordinance 20-027		Approved Basic 18 116039		2019
New	Expiration date extended 120 days per Emergency Ordinance 20-027		Approved Basic 17-111208		2019
New	Approved basic 16-116039 BP	2015 IRC	Plan# Hazelwood D	2-story SFR w/att	2019
New	Expiration date extended 120 days per Emergency Ordinance 20-027		Approved Basic 17-107523		2019

Accessory Dwelling Units

Index # - File Name: 1.0022 - Single Family Dwellings Data\_Snohomish County.pdf

New	Approved Basic 17-109820BP	2015 IRC	PLAN: Tye C/D	2620sf 3 story SFR v	2019
New	Approved Basic 17-109820BP	2015 IRC	PLAN: Tye C/D	2620sf 3 story SFR v	2019
New	Approved Basic 17-107523 BP	2015 IRC	Plan Granite C	2 story sfr with atta	2019
New	Approved Basic 17-107522 BP	2015 IRC	Plan Granite D	2 story sfr with atta	2019
New	Approved Basic 17-107522 BP	2015 IRC	Plan Granite D	2 story sfr with atta	2019
New	Approved basic 18-151505 BP	2015 IRC	Plan# 2337 AB	3-story sfr w/attached gara	2019
New	Approved basic 18-151506 BP	2015 IRC	Plan# 2581	3-story sfr w/attached gai	2019
New	Approved basic 18-151505 BP	2015 IRC	Plan# 2337 AB	3-story sfr w/attached gara	2019
New	Approved Basic 17-107067 BP	2015 IRC	Plan 2101 A/B	2 story sfr with attach	2019
New	Approved Basic 17-107067 BP	2015 IRC	Plan 2101 A/B	2 story sfr with attach	2019
New	Approved basic 18-151506 BP	2015 IRC	Plan# 2581	3-story sfr w/attached gai	2019
New	Approved Basic 17-107067 BP	2015 IRC	Plan 2101 A/B	2 story sfr with attach	2019
New	Approved Basic 17-107067 BP	2015 IRC	Plan 2101 A/B	2 story sfr with attach	2019
New	Approved basic 18-151506 BP	2015 IRC	Plan# 2581	3-story sfr w/attached gai	2019
New	Approved basic 18-151505 BP	2015 IRC	Plan# 2337 AB	3-story sfr w/attached gara	2019
New	Approved basic 18-151505 BP	2015 IRC	Plan# 2337 AB	3-story sfr w/attached gara	2019
New	Approved basic 18-151505 BP	2015 IRC	Plan# 2337 AB	3-story sfr w/attached gara	2019
New	Approved Basic 17-107067 BP	2015 IRC	Plan 2101 A/B	2 story sfr with attach	2019
New	Approved basic 18-151505 BP	2015 IRC	Plan# 2337 AB	3-story sfr w/attached gara	2019
New	Approved basic 18-151505 BP	2015 IRC	Plan# 2337 AB	3-story sfr w/attached gara	2019
New	Approved Basic 17-107067 BP	2015 IRC	Plan 2101 A/B	2 story sfr with attach	2019
New	Approved basic 18-151505 BP	2015 IRC	Plan# 2337 AB	3-story sfr w/attached gara	2019
New	Expiration date extended 120 days per Emergency Ordinance 20-027	EPERMIT	Description of W		2019
New	***04/17/2019 DJL- Issue with LDA, D1, I emailed Annie & Shawn for the D1 to be issued...waiti				2019
New	Expiration date extended 120 days per Emergency Ordinance 20-027	Approved Basic 19-102382			2019
New	Expiration date extended 120 days per Emergency Ordinance 20-027	Approved Basic 19-102382			2019
New	Approved Basic 18-126600 BP	2015 IRC	PLAN: 04GN-C	2725sf two story sfr with a	2019
New	Approved Basic 18-122185BP	2015 IRC	PLAN: 02GN-C	2582sf two story S	2019
New	Approved Basic 19-102512 BP	2015 IRC	PLAN: 06GN-C	2710sf two story S	2019
New	Approved Basic 18-122183BP	2015 IRC	PLAN: 02GN-A	2582sf two story SFR with	2019
New	Approved Basic 19-102513BP	2015 IRC	PLAN: 06GN-B	2710sf two story S	2019
New	Approved Basic 18-121903BP	2015 IRC	PLAN: 01GN-C	2425sf two story SFR v	2019
New	Approved Basic 18-122183BP	2015 IRC	PLAN: 02GN-A	2582sf two story SFR with	2019
New	Approved Basic 18-122185BP	2015 IRC	PLAN: 02GN-C	2582sf two story S	2019
New	Approved Basic 19-102512BP	2015 IRC	PLAN: 06GN-C	2710sf two story S	2019
New	EPERMIT Description of Work: SFR for one home on existing legal parcel. Applicant processing 4				2019
New	EPERMIT Description of Work: Single Family new construction				2019
New	Expiration date extended 120 days per Emergency Ordinance 20-027	EPERMIT	Description of W		2019
New	Expiration date extended 120 days per Emergency Ordinance 20-027	EPERMIT	Description of W		2019
New	Expiration date extended 120 days per Emergency Ordinance 20-027	EPERMIT	Description of W		2019
New	Expiration date extended 120 days per Emergency Ordinance 20-027	EPERMIT	Description of W		2019
New	Expiration date extended 120 days per Emergency Ordinance 20-027	EPERMIT	Description of W		2019
New	Expiration date extended 120 days per Emergency Ordinance 20-027	EPERMIT	Description of W		2019
New	Expiration date extended 120 days per Emergency Ordinance 20-027	Approved basic 19-109118			2019
New	Expiration date extended 120 days per Emergency Ordinance 20-027	Approved basic 19-109174			2019
New	Expiration date extended 120 days per Emergency Ordinance 20-027	Approved basic 19-109201			2019



Accessory Dwelling Units

Index # - File Name: 1.0022 - Single Family Dwellings Data\_Snohomish County.pdf

New	Expiration date extended 120 days per Emergency Ordinance 20-027	Approved basic 19-109201	2019
New	Expiration date extended 120 days per Emergency Ordinance 20-027	Approved basic 19-104995	2019
New	Approved basic 19-103223 BP 2015 IRC Plan# 2008 ABF v2	2-story sfr w/attach	2019
New	Approved basic 19-101581 BP 2015 IRC Plan# 2431 ABC 2015 IRC v2	3-story sfr w	2019
New	Approved basic 19-104995 BP 2015 IRC Plan 2301-02ABC	2301sf 3-story sfr w/attached g	2019
New	Approved basic 19-103223 BP 2015 IRC Plan# 2008 ABF v2	2-story sfr w/attach	2019
New	Approved basic 19-104995 BP 2015 IRC Plan 2301-02ABC	2301sf 3-story sfr w/attached g	2019
New	Expiration date extended 120 days per Emergency Ordinance 20-027	Approved Basic 17-118650	2019
New	Expiration date extended 120 days per Emergency Ordinance 20-027	Approved Basic 18-123321	2019
New	Expiration date extended 120 days per Emergency Ordinance 20-027	Approved Basic 18-123321	2019
New	Expiration date extended 120 days per Emergency Ordinance 20-027	Approved Basic 18-123321	2019
New	Expiration date extended 120 days per Emergency Ordinance 20-027	Approved Basic 18-123321	2019
New	Approved basic 19-103223 BP 2015 IRC Plan# 2008 ABF v2	2-story sfr w/attach	2019
New	Expiration date extended 120 days per Emergency Ordinance 20-027	Approved basic 19-104995	2019
New	Expiration date extended 120 days per Emergency Ordinance 20-027	Approved Basic 17-118650	2019
New	Expiration date extended 120 days per Emergency Ordinance 20-027	Approved basic 19-103223	2019
New	Expiration date extended 120 days per Emergency Ordinance 20-027	Approved basic 19-104995	2019
New	Expiration date extended 120 days per Emergency Ordinance 20-027	Approved basic 19-103223	2019
New	Expiration date extended 120 days per Emergency Ordinance 20-027	Approved basic 19-104995	2019
New	Expiration date extended 120 days per Emergency Ordinance 20-027	Approved basic 19-103223	2019
New	Expiration date extended 120 days per Emergency Ordinance 20-027	Approved Basic 17-119362	2019
New	Approved Basic 17-118650 BP 2015 IRC PLAN: 2431 AB	2431sf three story S	2019
New	Approved Basic 17-119362 BP 2015 IRC PLAN: 2175 AB 2015	2175sf three story SFR	2019
New	Approved Basic 17-118650 BP 2015 IRC PLAN: 2431 AB	2431sf three story S	2019
New	Expiration date extended 120 days per Emergency Ordinance 20-027	Approved basic 19-103422	2019
New	Expiration date extended 120 days per Emergency Ordinance 20-027	Approved Basic 17-118650	2019
New	Expiration date extended 120 days per Emergency Ordinance 20-027	Approved basic 19-103422	2019
New	Expiration date extended 120 days per Emergency Ordinance 20-027	EPERMIT E19-06957 Descr	2019
New	EPERMIT: Construction of single family detached home		2019
New	Expiration date extended 120 days per Emergency Ordinance 20-027	EPERMIT: Construction of	2019
New	Expiration date extended 120 days per Emergency Ordinance 20-027	Approved basic 19-109201	2019
New	Expiration date extended 120 days per Emergency Ordinance 20-027	Approved basic 19-109118	2019
New	Expiration date extended 120 days per Emergency Ordinance 20-027	EPERMIT Description of W	2019
New	Expiration date extended 120 days per Emergency Ordinance 20-027	Approved basic 19-109174	2019
New	EPERMIT Description of Work: Converting an existing 504 sq ft garage (not permitted) on Lot 51		2019
New	2018 28 8 X 56 Fleetwood Double-wide Mobile Home	Documents can be found in Pro folder	2019
New	Expiration date extended 120 days per Emergency Ordinance 20-027	EPERMIT Description of W	2019
New	Approved basic 19-107974 BP 2015 IRC Plan: Rainier 2 D Elev	2-story sfr w/attached garağ	2019
New	Approved basic 19-106717BP 2015 IRC Newhalem 2 D Plan	2-story sfr w/attached garage	2019
New	Approved basic 19-107966 BP 2015 IRC Plan: Rainier 2 C Elev	2-story sfr w/attached garağ	2019
New	Approved Basic 18 116039BP 2015 irc Trafton 2-C	2410 Sq ft 4 bedroom with attached	2019
New	Expiration date extended 120 days per Emergency Ordinance 20-027	Approved basic 19-107966	2019
New	Approved basic 19-106718BP 2015 IRC Newhalem 2 C Plan	2 story sfr w/attached garage	2019
New	Expiration date extended 120 days per Emergency Ordinance 20-027	Approved basic 19-107974	2019
New	Expiration date extended 120 days per Emergency Ordinance 20-027	Approved Basic 18 116043	2019
New	Expiration date extended 120 days per Emergency Ordinance 20-027	Approved Basic 18 116039	2019
New	Approved basic 19-106257 BP 2015 IRC Kimball 2 C/D Daylight	2-stroy SFR w/finished base	2019

Accessory Dwelling Units

Index # - File Name: 1.0022 - Single Family Dwellings Data\_Snohomish County.pdf

New	Expiration date extended 120 days per Emergency Ordinance 20-027 Approved basic 19-10632	2019
New	Approved Basic 18-118943BP 2015 IRC PLAN: Baker 2 2682sf two story SFR with	2019
New	Approved Basic 18-118943BP 2015 IRC PLAN: Baker 2 2682sf two story SFR with	2019
New	Approved Basic 18 116039BP 2015 irc Trafton 2-C 2410 Sq ft 4 bedroom with attached	2019
New	Expiration date extended 120 days per Emergency Ordinance 20-027 Approved Basic 18118272	2019
New	Expiration date extended 120 days per Emergency Ordinance 20-027 Approved basic 19-107974	2019
New	Expiration date extended 120 days per Emergency Ordinance 20-027 Approved Basic 18118272	2019
New	Expiration date extended 120 days per Emergency Ordinance 20-027 Approved basic 19-106717	2019
New	Expiration date extended 120 days per Emergency Ordinance 20-027 Approved Basic 18118272	2019
New	Expiration date extended 120 days per Emergency Ordinance 20-027 Approved basic 19-107966	2019
New	Approved Basic 18118272 BP 2015 IRC Plan# Kimball 2 C D 2-story sfr w/at	2019
New	Approved basic 19-102395 BP 2015 IRC Plan 2212 2212sf rambler with attached	2019
New	Approved Basic 18-127315BP 2015 IRC PLAN: 2409 2409 sf rambler with attached	2019
New	Approved Basic 18-151365BP 2015 IRC PLAN: 2402 35# Snow Load 2402sf single sf	2019
New	Approved basic 19-102395 BP 2015 IRC Plan 2212 2212sf rambler with attached	2019
New	Approved Basic 18-127315BP 2015 IRC PLAN: 2409 2409 sf rambler with attached	2019
New	Approved basic 16-120708 BP 2015 IRC Plan# 3484 2-story sfr w/attache	2019
New	***04/17/2019 DJL- Impact receipt 04/02/2019 uploaded, 2nd fees MIT fees sent today*** Ap	2019
New	Expiration date extended 120 days per Emergency Ordinance 20-027 Approved Basic 18-126212	2019
New	Expiration date extended 120 days per Emergency Ordinance 20-027 Approved basic 19-115551	2019
New	Expiration date extended 120 days per Emergency Ordinance 20-027 EPERMIT Description of W	2019
New	Approved basic 18-151577 BP 2015 IRC Plan# 2518 ABC 2015 V2 3-story sfr	2019
New	Approved Basic 17-118650 BP 2015 IRC PLAN: 2431 AB 2431sf three story S	2019
New	Expiration date extended 120 days per Emergency Ordinance 20-027 Approved Basic 17-118650	2019
New	Approved Basic 18-120929BP 2015 IRC PLAN: 2418ABC v 2 2418sf three story	2019
New	Approved Basic 17-119362 BP 2015 IRC PLAN: 2175 AB 2015 2175sf three story SFR	2019
New	Approved Basic 18-120929BP 2015 IRC PLAN: 2418ABC v 2 2418sf three story	2019
New	Expiration date extended 120 days per Emergency Ordinance 20-027 Approved Basic 17-118650	2019
New	Expiration date extended 120 days per Emergency Ordinance 20-027 Approved Basic 17-118650	2019
New	Approved basic 18-151577 BP 2015 IRC Plan# 2518 ABC 2015 V2 3-story sfr	2019
New	Expiration date extended 120 days per Emergency Ordinance 20-027 Approved basic 19-113524	2019
New	Approved Basic 17-118650 BP 2015 IRC PLAN: 2431 AB 2431sf three story S	2019
New	Expiration date extended 120 days per Emergency Ordinance 20-027 Approved Basic 18-120929	2019
New	Expiration date extended 120 days per Emergency Ordinance 20-027 Approved basic 19-113524	2019
New	Expiration date extended 120 days per Emergency Ordinance 20-027 Approved Basic 17-118650	2019
New	Expiration date extended 120 days per Emergency Ordinance 20-027 Approved Basic 18-120929	2019
New	Expiration date extended 120 days per Emergency Ordinance 20-027 Approved Basic 17-118650	2019
New	Expiration date extended 120 days per Emergency Ordinance 20-027 Approved Basic 18-120929	2019
New	Expiration date extended 120 days per Emergency Ordinance 20-027 Approved basic 19-113524	2019
New	Expiration date extended 120 days per Emergency Ordinance 20-027 Approved basic 19-113524	2019
New	Expiration date extended 120 days per Emergency Ordinance 20-027 Approved basic 19-113524	2019
New	Expiration date extended 120 days per Emergency Ordinance 20-027 Approved basic 19-113524	2019
New	Expiration date extended 120 days per Emergency Ordinance 20-027 Approved Basic 18-120927	2019
New	Expiration date extended 120 days per Emergency Ordinance 20-027 EPERMIT Description of W	2019
New	Approved Basic 18118272 BP 2015 IRC Plan# Kimball 2 C D 2-story sfr w/at	2019
New	Approved Basic 18 116043BP 2015 irc Trafton 2-D 2410 Sq ft 4 bedroom with attached	2019
New	Approved Basic 16-113032 BP 2015 IRC Plan# Rainier C 2-story sfr w/attached g	2019
New	Expiration date extended 120 days per Emergency Ordinance 20-027 Approved Basic 18 116039	2019

Accessory Dwelling Units

Index # - File Name: 1.0022 - Single Family Dwellings Data\_Snohomish County.pdf

New	Approved Basic 16-113032 BP	2015 IRC	Plan# Rainier C	2-story sfr w/attached g	2019
New	Approved Basic 18118272 BP	2015 IRC	Plan# Kimball 2 C D	2-story sfr w/at	2019
New	Approved Basic 18 116043BP	2015 irc	Trafton 2-D	2410 Sq ft 4 bedroom with attached	2019
New	Approved basic 16-113033 BP	2015 IRC	Plan# Rainier D	2-story sfr w/attached g	2019
New	Approved Basic 18 116039BP	2015 irc	Trafton 2-C	2410 Sq ft 4 bedroom with attached	2019
New	Expiration date extended 120 days per Emergency Ordinance 20-027 Approved Basic 18118272				2019
New	Expiration date extended 120 days per Emergency Ordinance 20-027 Approved Basic 16-113032				2019
New	Expiration date extended 120 days per Emergency Ordinance 20-027 Approved Basic 18 116039				2019
New	Expiration date extended 120 days per Emergency Ordinance 20-027 Approved basic 16-113033				2019
New	Expiration date extended 120 days per Emergency Ordinance 20-027 Approved Basic 18118272				2019
New	Expiration date extended 120 days per Emergency Ordinance 20-027 Approved Basic 18 116043				2019
New	EPERMIT Description of Work: Manufactured Home (new, 1998 double wide) 25 x 66				2019
New	Airport Influence Area Disclosure AFN 201903290105 EPERMIT Description of Work: Build a 3 f				2019
New	Approved Basic 18-120927BP	IRC: 2015	PLAN: 2210EF	2210sf three story SFR wit	2019
New	Expiration date extended 120 days per Emergency Ordinance 20-027 Approved basic 19-113524				2019
New	Approved Basic 18-120929BP	2015 IRC	PLAN: 2418ABC v 2	2418sf three story	2019
New	Expiration date extended 120 days per Emergency Ordinance 20-027 Approved basic 19-113524				2019
New	EPERMIT Description of Work: New SFR. SFR consists of 1260 sf of living space (1st floor is 359 s				2019
New	28 x 60 Guerdon Double Wide This permit is to final expired permit #237787				2019
New	Approved basic 17-100648 BP	2015 IRC	Plan# Armstrong Daylight C/D	2story sfr	2019
New	Expiration date extended 120 days per Emergency Ordinance 20-027 Approved Basic 18-124980				2019
New	Expiration date extended 120 days per Emergency Ordinance 20-027 Approved basic 19-106209				2019
New	Approved basic 16-118186 BP	2015 IRC	Plan# 2060 (25# snow load)		2019
New	Approved basic 16-118176 BP	2015 IRC	Plan# 2541 (25# snow load)		2019
New	Approved basic 16-118186 BP	2015 IRC	Plan# 2060 (25# snow load)		2019
New	Approved basic 17-105451 BP	2015 IRC	Plan# 2477 (38#)	2 story SI	2019
New	Approved basic 16-118186 BP	2015 IRC	Plan# 2060 (25# snow load)		2019
New	Approved basic 16-118176 BP	2015 IRC	Plan# 2541 (25# snow load)		2019
New	Expiration date extended 120 days per Emergency Ordinance 20-027 Approved Basic 19-118062				2019
New	Expiration date extended 120 days per Emergency Ordinance 20-027 Approved basic 16-118177				2019
New	Expiration date extended 120 days per Emergency Ordinance 20-027 Approved basic 17-105451				2019
New	Approved basic 16-118177 BP	2015 IRC	Plan# 2370 (25# snow load)		2019
New	Approved basic 16-118186 BP	2015 IRC	Plan# 2060 (25# snow load)		2019
New	Approved basic 17-105451 BP	2015 IRC	Plan# 2477 (38#)	2 story SI	2019
New	EPERMIT Description of Work: Building SFR for spec				2019
New	EPERMIT Description of Work: Construction new single family residence Associated Permit: 19-1				2019
New	Expiration date extended 120 days per Emergency Ordinance 20-027 EPERMIT Description of W				2019
New	Expiration date extended 120 days per Emergency Ordinance 20-027 EPERMIT Description of W				2019
New	EPERMIT Description of Work: New single family residence Associated Permit: 19- 106921-LDA,				2019
New	Expiration date extended 120 days per Emergency Ordinance 20-027 Approved basic 19-103759				2019
New	Expiration date extended 120 days per Emergency Ordinance 20-027 Approved basic 19-103759				2019
New	Expiration date extended 120 days per Emergency Ordinance 20-027 Approved basic 19-103759				2019
New	Approved basic 16-119384 BP	2015 IRC	Plan# 2552	2-story sfr w/base	2019
New	Approved Basic 17 113549 BP	2015 IRC 3006		2 story w/basement	2019
New	Expiration date extended 120 days per Emergency Ordinance 20-027 Approved basic 16-119384				2019
New	Expiration date extended 120 days per Emergency Ordinance 20-027 Approved Basic 17 113549				2019
New	Expiration date extended 120 days per Emergency Ordinance 20-027 Approved Basic 17 113549				2019

Accessory Dwelling Units

Index # - File Name: 1.0022 - Single Family Dwellings Data\_Snohomish County.pdf

New	Expiration date extended 120 days per Emergency Ordinance 20-027 Approved Basic 18-124969	2019
New	Expiration date extended 120 days per Emergency Ordinance 20-027 Approved basic 17-100648	2019
New	Expiration date extended 120 days per Emergency Ordinance 20-027 Approved Basic 18-124980	2019
New	Approved basic 19-106209 BP 2015 IRC Plan# NEWHALEM 2 C DAYLIGHT 2-story sfr w	2019
New	Approved basic 19-106328BP 2015 IRC Newhalem 2 D Daylight 2-story SRF w/finished ba	2019
New	Approved Basic 18-124981BP 2015 IRC PLAN: Baker 2 C/D Daylight 3513sf three sto	2019
New	Expiration date extended 120 days per Emergency Ordinance 20-027 Approved basic 16-120708	2019
New	Expiration date extended 120 days per Emergency Ordinance 20-027 Approved basic 16-114079	2019
New	Expiration date extended 120 days per Emergency Ordinance 20-027 EPERMIT Description of W	2019
New	Expiration date extended 120 days per Emergency Ordinance 20-027 EPERMIT Description of W	2019
New	Expiration date extended 120 days per Emergency Ordinance 20-027 EPERMIT Description of W	2019
New	Expiration date extended 120 days per Emergency Ordinance 20-027 EPERMIT Description of W	2019
New	Expiration date extended 120 days per Emergency Ordinance 20-027 Approved basic 19-108704	2019
New	Expiration date extended 120 days per Emergency Ordinance 20-027 Approved basic 16-113278	2019
New	Expiration date extended 120 days per Emergency Ordinance 20-027 Approved basic 19-103675	2019
New	Expiration date extended 120 days per Emergency Ordinance 20-027 Approved Basic 18118272	2019
New	Expiration date extended 120 days per Emergency Ordinance 20-027 Approved basic 19-10367	2019
New	Expiration date extended 120 days per Emergency Ordinance 20-027 Approved basic 19-103677	2019
New	Approved Basic 18 116039BP 2015 irc Trafton 2-C 2410 Sq ft 4 bedroom with attached	2019
New	Approved basic 19-103678 BP 2015 IRC Plan: Hudson C D 2-story SFR w/attached garage	2019
New	Approved basic 19-103667 BP 2015 IRC Plan: Thompson D 2-story SFR w/attached garag	2019
New	Approved Basic 18 116043BP 2015 irc Trafton 2-D 2410 Sq ft 4 bedroom with attached	2019
New	Approved basic 19-103671 BP 2015 IRC Plan: Lennon C D 2-story SFR w/attached garage	2019
New	Approved basic 19-108735 BP 2015 IRC Skagit Elev D Plan 2-story sfr w/attached garage	2019
New	Approved Basic 18118272 BP 2015 IRC Plan# Kimball 2 C D 2-story sfr w/at	2019
New	Approved Basic 18-118943BP 2015 IRC PLAN: Baker 2 2682sf two story SFR with	2019
New	Approved basic 19-103675 BP 2015 IRC Plan: Shannon C D 2-story SFR w/attached garag	2019
New	Approved basic 19-103677 BP 2015 IRC Plan: Thelon C D 2-story SFR w/attached garage	2019
New	Approved basic 19-103664 BP 2015 IRC Plan: Thompson C 2-story SFR w/attached garag	2019
New	Approved Basic 17-112478BP 2015 IRC PLAN: Skagit D 2779 sf two story	2019
New	Approved Basic 18-118943BP 2015 IRC PLAN: Baker 2 2682sf two story SFR with	2019
New	Approved basic 19-108708 BP 2015 IRC Olympic Plan C/D Elev 2-story sfr w/attached garag	2019
New	Expiration date extended 120 days per Emergency Ordinance 20-027 Approved Basic 18118272	2019
New	Expiration date extended 120 days per Emergency Ordinance 20-027 Approved Basic 18-118943	2019
New	Expiration date extended 120 days per Emergency Ordinance 20-027 Approved basic 19-108704	2019
New	Expiration date extended 120 days per Emergency Ordinance 20-027 Approved Basic 18-118943	2019
New	Expiration date extended 120 days per Emergency Ordinance 20-027 Approved basic 19-106257	2019
New	Expiration date extended 120 days per Emergency Ordinance 20-027 Approved basic 19-103678	2019
New	Expiration date extended 120 days per Emergency Ordinance 20-027 Approved Basic 18-118943	2019
New	Expiration date extended 120 days per Emergency Ordinance 20-027 Approved basic 19-108735	2019
New	Approved basic 19-102410 BP 2015 IRC Plan 2766 ABC (35# snow load) 2766sf ran	2019
New	Expiration date extended 120 days per Emergency Ordinance 20-027 Approved basic 19-106054	2019
New	Expiration date extended 120 days per Emergency Ordinance 20-027 Approved Basic 18-12498	2019
New	Expiration date extended 120 days per Emergency Ordinance 20-027 Approved basic 19-106054	2019
New	Approved Basic 18-124981BP 2015 IRC PLAN: Baker 2 C/D Daylight 3513sf three sto	2019
New	Approved basic 19-108708 BP 2015 IRC Olympic Plan C/D Elev 2-story sfr w/attached garag	2019
New	Approved Basic 18-118943BP 2015 IRC PLAN: Baker 2 2682sf two story SFR with	2019

Accessory Dwelling Units

Index # - File Name: 1.0022 - Single Family Dwellings Data\_Snohomish County.pdf

New	Approved basic 19-103678 BP	2015 IRC	Plan: Hudson C D	2-story SFR w/attached garage	2019
New	Approved basic 16-113278 BP	2015 IRC	Plan# Chelan II D	2-story sfr w/attached garage	2019
New	Approved basic 19-103671 BP	2015 IRC	Plan: Lennon C D	2-story SFR w/attached garage	2019
New	Approved basic 19-103664 BP	2015 IRC	Plan: Thompson C	2-story SFR w/attached garage	2019
New	Expiration date extended 120 days per Emergency Ordinance 20-027	Approved basic 19-108708			2019
New	Expiration date extended 120 days per Emergency Ordinance 20-027	Approved basic 19-103678			2019
New	Expiration date extended 120 days per Emergency Ordinance 20-027	Approved basic 19-103675			2019
New	Expiration date extended 120 days per Emergency Ordinance 20-027	EPERMIT Description of W			2019
New	Expiration date extended 120 days per Emergency Ordinance 20-027	EPERMIT Description of W			2019
New	Expiration date extended 120 days per Emergency Ordinance 20-027	EPERMIT Description of W			2019
New	Expiration date extended 120 days per Emergency Ordinance 20-027	Approved basic 19-103675			2019
New	Expiration date extended 120 days per Emergency Ordinance 20-027	Approved basic 19-103678			2019
New	Expiration date extended 120 days per Emergency Ordinance 20-027	Approved basic 19-103677			2019
New	Expiration date extended 120 days per Emergency Ordinance 20-027	Approved basic 19-108708			2019
New	Expiration date extended 120 days per Emergency Ordinance 20-027	Approved basic 16-113276			2019
New	Expiration date extended 120 days per Emergency Ordinance 20-027	EPERMIT Description of W			2019
New	Expiration date extended 120 days per Emergency Ordinance 20-027	Approved basic 19-112223			2019
New	Approved basic 19-112223 BP	2015 IRC	Plan 2384 C	2384 sf 3-story SFR w/attached garage	2019
New	Approved basic 19-112223 BP	2015 IRC	Plan 2384 C	2384 sf 3-story SFR w/attached garage	2019
New	Expiration date extended 120 days per Emergency Ordinance 20-027	EPERMIT Description of W			2019
New	Expiration date extended 120 days per Emergency Ordinance 20-027	EPERMIT: Residential built			2019
New	Expiration date extended 120 days per Emergency Ordinance 20-027	Approved basic 19-111416			2019
New	Expiration date extended 120 days per Emergency Ordinance 20-027	Approved basic 19-111416			2019
New	Expiration date extended 120 days per Emergency Ordinance 20-027	Approved basic 19-111739			2019
New	Expiration date extended 120 days per Emergency Ordinance 20-027	Approved basic 19-111729			2019
New	Expiration date extended 120 days per Emergency Ordinance 20-027	Approved basic 19-111732			2019
New	Expiration date extended 120 days per Emergency Ordinance 20-027	Approved basic 19-111729			2019
New	Expiration date extended 120 days per Emergency Ordinance 20-027	Approved basic 19-111739			2019
New	Expiration date extended 120 days per Emergency Ordinance 20-027	Approved basic 19-111416			2019
New	Approved Basic 17-109422	2015 IRC	PLAN# 2417-2015	2 story SFR /base	2019
New	Approved Basic 17 113549 BP	2015 IRC 3006		2 story w/basement	2019
New	Approved basic 16-119384 BP	2015 IRC	Plan# 2552	2-story sfr w/base	2019
New	Approved basic 16-119384 BP	2015 IRC	Plan# 2552	2-story sfr w/base	2019
New	Approved Basic 17-109422	2015 IRC	PLAN# 2417-2015	2 story SFR /base	2019
New	Approved basic 16-119384 BP	2015 IRC	Plan# 2552	2-story sfr w/base	2019
New	Approved Basic 17-109422	2015 IRC	PLAN# 2417-2015	2 story SFR /base	2019
New	Expiration date extended 120 days per Emergency Ordinance 20-027	Approved basic 16-119384			2019
New	Approved Basic 17-109422	2015 IRC	PLAN# 2417-2015	2 story SFR /base	2019
New	Expiration date extended 120 days per Emergency Ordinance 20-027	EPERMIT Description of W			2019
New	Expiration date extended 120 days per Emergency Ordinance 20-027	EPERMIT Description of W			2019
New	Expiration date extended 120 days per Emergency Ordinance 20-027	EPERMIT Description of W			2019
New	Expiration date extended 120 days per Emergency Ordinance 20-027	EPERMIT Description of W			2019
New	Expiration date extended 120 days per Emergency Ordinance 20-027	Approved basic 19-106718			2019
New	Expiration date extended 120 days per Emergency Ordinance 20-027	Approved basic 19-107974			2019
New	Expiration date extended 120 days per Emergency Ordinance 20-027	Approved basic 19-106717			2019
New	Expiration date extended 120 days per Emergency Ordinance 20-027	Approved basic 19-107966			2019

Accessory Dwelling Units

Index # - File Name: 1.0022 - Single Family Dwellings Data\_Snohomish County.pdf

New	Expiration date extended 120 days per Emergency Ordinance 20-027 Approved Basic 18-124969	2019
New	Expiration date extended 120 days per Emergency Ordinance 20-027 Approved basic 19-106257	2019
New	Expiration date extended 120 days per Emergency Ordinance 20-027 Approved Basic 18 116043	2019
New	Expiration date extended 120 days per Emergency Ordinance 20-027 Approved Basic 18118272	2019
New	Expiration date extended 120 days per Emergency Ordinance 20-027 Approved Basic 18-124969	2019
New	Approved basic 19-106257 BP 2015 IRC Kimball 2 C/D Daylight 2-story SFR w/finished base	2019
New	Approved basic 19-106718BP 2015 IRC Newhalem 2 C Plan 2 story SFR w/attached garage	2019
New	Approved Basic 18118272 BP 2015 IRC Plan# Kimball 2 C D 2-story sfr w/at	2019
New	Expiration date extended 120 days per Emergency Ordinance 20-027 EPERMIT Description of W	2019
New	Expiration date extended 120 days per Emergency Ordinance 20-027 EPERMIT Description of W	2019
New	Expiration date extended 120 days per Emergency Ordinance 20-027 EPERMIT Description of W	2019
New	Expiration date extended 120 days per Emergency Ordinance 20-027 EPERMIT Description of W	2019
New	Expiration date extended 120 days per Emergency Ordinance 20-027 Approved Basic 18-124751	2019
New	Expiration date extended 120 days per Emergency Ordinance 20-027 Approved Basic 18-124737	2019
New	Expiration date extended 120 days per Emergency Ordinance 20-027 Approved Basic 18-124737	2019
New	Expiration date extended 120 days per Emergency Ordinance 20-027 Approved Basic 18-124736	2019
New	Expiration date extended 120 days per Emergency Ordinance 20-027 Approved basic 19-106717	2019
New	Expiration date extended 120 days per Emergency Ordinance 20-027 Approved basic 19-107966	2019
New	Expiration date extended 120 days per Emergency Ordinance 20-027 Approved basic 16-113271	2019
New	Expiration date extended 120 days per Emergency Ordinance 20-027 Approved Basic 18 116039	2019
New	Expiration date extended 120 days per Emergency Ordinance 20-027 Approved basic 19-107974	2019
New	Approved Basic 18 116043BP 2015 irc Trafton 2-D 2410 Sq ft 4 bedroom with attached	2019
New	Approved basic 19-106718BP 2015 IRC Newhalem 2 C Plan 2 story sfr w/attached garage	2019
New	Approved Basic 18 116039BP 2015 irc Trafton 2-C 2410 Sq ft 4 bedroom with attached	2019
New	Expiration date extended 120 days per Emergency Ordinance 20-027 Approved basic 19-103677	2019
New	Expiration date extended 120 days per Emergency Ordinance 20-027 Approved basic 19-103675	2019
New	Expiration date extended 120 days per Emergency Ordinance 20-027 Approved basic 19-103678	2019
New	Expiration date extended 120 days per Emergency Ordinance 20-027 Approved basic 19-103677	2019
New	Expiration date extended 120 days per Emergency Ordinance 20-027 Approved basic 19-111423	2019
New	Expiration date extended 120 days per Emergency Ordinance 20-027 Approved basic 19-111424	2019
New	Expiration date extended 120 days per Emergency Ordinance 20-027 Approved basic 19-111424	2019
New	Expiration date extended 120 days per Emergency Ordinance 20-027 EPERMIT Description of W	2019
New	Expiration date extended 120 days per Emergency Ordinance 20-027 Approved basic 19-111423	2019
New	Approved basic 19-111424 BP 2015 IRC Plan 2218 2218 sf rambler w/attached garage **	2019
New	Expiration date extended 120 days per Emergency Ordinance 20-027 Approved Basic 18-124956	2019
New	Expiration date extended 120 days per Emergency Ordinance 20-027 Approved Basic 18-124947	2019
New	Approved Basic 16-113032 BP 2015 IRC Plan# Rainier C 2-story sfr w/attached g	2019
New	Expiration date extended 120 days per Emergency Ordinance 20-027 Approved Basic 18-124955	2019
New	EPERMIT Description of Work: Install 27 x 56 new manufactured home on undeveloped land and	2019
New	Approved basic 19-103979BP 2015 IRC Plan: 2273CD 2 story SFR w/attached garage	2019
New	Expiration date extended 120 days per Emergency Ordinance 20-027 Approved basic 19-112631	2019
New	Expiration date extended 120 days per Emergency Ordinance 20-027 Approved basic 19-11264	2019
New	Expiration date extended 120 days per Emergency Ordinance 20-027 Approved basic 19-112614	2019
New	Expiration date extended 120 days per Emergency Ordinance 20-027 Approved basic 19-112613	2019
New	Expiration date extended 120 days per Emergency Ordinance 20-027 Approved Basic 17-107067	2019
New	Expiration date extended 120 days per Emergency Ordinance 20-027 Approved basic 19-103750	2019
New	Expiration date extended 120 days per Emergency Ordinance 20-027 Approved basic 19-114560	2019

Accessory Dwelling Units

Index # - File Name: 1.0022 - Single Family Dwellings Data\_Snohomish County.pdf

New	Expiration date extended 120 days per Emergency Ordinance 20-027 Approved basic	19-11761	2019
New	Expiration date extended 120 days per Emergency Ordinance 20-027 Approved basic	19-114557	2019
New	Expiration date extended 120 days per Emergency Ordinance 20-027 Approved basic	19-114560	2019
New	Expiration date extended 120 days per Emergency Ordinance 20-027 ***airport influence doc 2		2019
New	Approved Basic 18-124996BP 2015 IRC PLAN: 3140B (434) 3140sf two story SFR		2019
New	Expiration date extended 120 days per Emergency Ordinance 20-027 Approved basic	19-114560	2019
New	Expiration date extended 120 days per Emergency Ordinance 20-027 Approved basic	19-114557	2019
New	Expiration date extended 120 days per Emergency Ordinance 20-027 Approved basic	19-103678	2019
New	Expiration date extended 120 days per Emergency Ordinance 20-027 Approved basic	19-11455	2019
New	Expiration date extended 120 days per Emergency Ordinance 20-027 Approved basic	19-117617	2019
New	New one story SFR		2019
New	Expiration date extended 120 days per Emergency Ordinance 20-027 Approved basic	19-117616	2020
New	Expiration date extended 120 days per Emergency Ordinance 20-027 Approved basic	19-111424	2020
New	Approved basic 19-117617 BP 2015 IRC Plan 2989 C GLR 2-story SFR w/attached garage		2020
New	Approved basic 19-114557 BP 2015 IRC Plan 2501 A GLR 2-story sfr w/attached garage		2020
New	Approved basic 19-117617 BP 2015 IRC Plan 2989 C GLR 2-story sfr w/attached garage		2020
New	Approved basic 19-117616BP 2015 IRC Plan# 2501 B GLR 2-story SFR w/attached		2020
New	Approved basic 19-114560 BP 2015 IRC Plan# 2989 A GLR 2-story SFR w/attached		2020
New	Approved basic 19-117616BP 2015 IRC Plan# 2501 B GLR 2-story SFR w/attached		2020
New	Expiration date extended 120 days per Emergency Ordinance 20-027 Approved Basic	18-12499	2020
New	Expiration date extended 120 days per Emergency Ordinance 20-027 Approved Basic	18-12499	2020
New	Expiration date extended 120 days per Emergency Ordinance 20-027 Approved Basic	18-12621	2020
New	Expiration date extended 120 days per Emergency Ordinance 20-027 Approved basic	20-101112	2020
New	Expiration date extended 120 days per Emergency Ordinance 20-027 Approved basic	19-112641	2020
New	Expiration date extended 120 days per Emergency Ordinance 20-027 Approved basic	19-112638	2020
New	Expiration date extended 120 days per Emergency Ordinance 20-027 Approved basic	19-11261	2020
New	Expiration date extended 120 days per Emergency Ordinance 20-027 Approved basic	17-105451	2020
New	Expiration date extended 120 days per Emergency Ordinance 20-027 Approved basic	16-118176	2020
New	Application Expiration date extended 120 days per Emergency Ordinance 20-027 Approved basi		2020
New	Expiration date extended 120 days per Emergency Ordinance 20-027 Approved basic	19-114674	2020
New	Application Expiration date extended 120 days per Emergency Ordinance 20-027 EPERMIT Desc		2020
New	Application Expiration date extended 120 days per Emergency Ordinance 20-027 EPERMIT Desc		2020
New	Application Expiration date extended 120 days per Emergency Ordinance 20-027 Approved bas		2020
New	Approved basic 19-106209 BP 2015 IRC Plan# NEWHALEM 2 C DAYLIGHT 2-story sfr w		2020
New	Application Expiration date extended 120 days per Emergency Ordinance 20-027 Approved Basi		2020
New	Application Expiration date extended 120 days per Emergency Ordinance 20-027 Approved Basi		2020
New	Application Expiration date extended 120 days per Emergency Ordinance 20-027 Approved Basi		2020
New	Application Expiration date extended 120 days per Emergency Ordinance 20-027 Approved Basi		2020
New	Approved Basic 18118272 BP 2015 IRC Plan# Kimball 2 C D 2-story SFR w/attache		2020
New	Application Expiration date extended 120 days per Emergency Ordinance 20-027 Approved basi		2020
New	Approved Basic 18118272 BP 2015 IRC Plan# Kimball 2 C D 2-story SFR w/attache		2020
New	Approved Basic 18-124969BP 2015 IRC PLAN: Trafton 2 D Daylight 3102sf three s		2020
New	Approved basic 19-106209 BP 2015 IRC Plan# NEWHALEM 2 C DAYLIGHT 2-story sfr w		2020
New	Approved Basic 18-124980BP 2015 IRC PLAN: Trafton 2 C Daylight 3102sf three st		2020
New	Approved basic 19-106717BP 2015 IRC Newhalem 2 D Plan 2-story sfr w/attached garage		2020
New	Approved Basic 18 116043BP 2015 irc Trafton 2-D 2410 Sq ft 4 bedroom with attached		2020
New	Approved Basic 18118272 BP 2015 IRC Plan# Kimball 2 C D 2-story SFR w/attache		2020

Accessory Dwelling Units

Index # - File Name: 1.0022 - Single Family Dwellings Data\_Snohomish County.pdf

New	Approved basic 19-107974 BP	2015 IRC	Plan: Rainier 2 D Elevation	2-story SFR w/attached	2020
New	Approved basic 16-115149 BP	2015 IRC	Plan# Windom C/D	2-story sfr w/finish	2020
New	Approved Basic 19-115639 BP	2015 IRC	Plan# ASPEN 2D	2-story SFR w/fini	2020
New	Approved basic 16-115149 BP	2015 IRC	Plan# Windom C/D	2-story SFR w/finis	2020
New	Approved basic 19-106717BP	2015 IRC	Newhalem 2 D Plan	2-story sfr w/attached garage	2020
New	Approved Basic 18 116039BP	2015 irc	Trafton 2-C	2410 Sq ft 4 bedroom with attached	2020
New	Approved basic 19-106718BP	2015 IRC	Newhalem 2 C Plan	2 story sfr w/attached garage	2020
New	Approved Basic 18 116043BP	2015 irc	Trafton 2-D	2410 Sq ft 4 bedroom with attached	2020
New	Expiration date extended 120 days per Emergency Ordinance 20-027		New 3,019 Sqft house. Usi		2020
New	Application Expiration date extended 120 days per Emergency Ordinance 20-027		EPERMIT: Resi		2020
New	Application Expiration date extended 120 days per Emergency Ordinance 20-027		EPERMIT: Resi		2020
New	Expiration date extended 120 days per Emergency Ordinance 20-027		EPERMIT: Residential builc		2020
New	Expiration date extended 120 days per Emergency Ordinance 20-027		EPERMIT Description of W		2020
New	Application Expiration date extended 120 days per Emergency Ordinance 20-027		EPERMIT Desc		2020
New	Expiration date extended 120 days per Emergency Ordinance 20-027		EPERMIT Description of W		2020
New	Application Expiration date extended 120 days per Emergency Ordinance 20-027		EPERMIT Desc		2020
New	Application Expiration date extended 120 days per Emergency Ordinance 20-027		EPERMIT Desc		2020
New	Application Expiration date extended 120 days per Emergency Ordinance 20-027		EPERMIT Desc		2020
New	Expiration date extended 120 days per Emergency Ordinance 20-027		Approved basic 19-118234		2020
New	Approved basic 19-118231 BP	2015 IRC	Plan CHANDLER C DUPLEX TYPE V-A	2 story d	2020
New	Expiration date extended 120 days per Emergency Ordinance 20-027		Approved basic 19-118231		2020
New	Approved basic 19-118229 BP	2015 IRC	Plan MADISON CD DUPLEX TYPE V-A	2-story dup	2020
New	Approved basic 19-118234 BP	2015 IRC	Plan# CHANDLER D DUPLEX TYPE V-A	2-story	2020
New	Expiration date extended 120 days per Emergency Ordinance 20-027		Approved basic 19-118229		2020
New	Expiration date extended 120 days per Emergency Ordinance 20-027		Approved basic 19-118234		2020
New	Approved basic 19-118229 BP	2015 IRC	Plan MADISON CD DUPLEX TYPE V-A	2-story dup	2020
New	Approved basic 19-118229 BP	2015 IRC	Plan MADISON CD DUPLEX TYPE V-A	2-story dup	2020
New	Expiration date extended 120 days per Emergency Ordinance 20-027		EPERMIT Description of W		2020
New	Approved basic 20-106271 BP	2015 IRC	plan# 2340	Rambler style SFR w/attached g	2020
New	Approved basic 20-105866 BP	2015 IRC	Plan# 2708	Rambler style SFR w/attached ga	2020
New	Expiration date extended 120 days per Emergency Ordinance 20-027		Approved Basic 17-106927		2020
New	Expiration date extended 120 days per Emergency Ordinance 20-027		Approved Basic 17 114919		2020
New	Approved basic 20-106271 BP	2015 IRC	plan# 2340	Rambler style sfr w/attached ga	2020
New	Approved basic 20-105866 BP	2015 IRC	Plan# 2708	Rambler style sfr w/attached gai	2020
New	Expiration date extended 120 days per Emergency Ordinance 20-027		Approved Basic 17-111513		2020
New	Expiration date extended 120 days per Emergency Ordinance 20-027		Approved Basic 17 114919		2020
New	Expiration date extended 120 days per Emergency Ordinance 20-027		Approved Basic 17-106927		2020
New	Expiration date extended 120 days per Emergency Ordinance 20-027		Approved Basic 17 114919		2020
New	Expiration date extended 120 days per Emergency Ordinance 20-027		Approved Basic 17-111513		2020
New	Expiration date extended 120 days per Emergency Ordinance 20-027		Approved Basic 17-106927		2020
New	Expiration date extended 120 days per Emergency Ordinance 20-027		Approved Basic 17 114919		2020
New	Approved basic 20-105875 BP	2015 IRC	Plan# 2447 End Load	Ramble style SFR w	2020
New	Approved basic 20-106271 BP	2015 IRC	plan# 2340	Rambler style SFR w/attached g	2020
New	Expiration date extended 120 days per Emergency Ordinance 20-027		Approved Basic 17 114919		2020
New	Expiration date extended 120 days per Emergency Ordinance 20-027		Approved Basic 17-111513		2020
New	Approved basic 20-105875 BP	2015 IRC	Plan# 2447 End Load	Ramble style SFR w	2020
New	Application Expiration date extended 120 days per Emergency Ordinance 20-027		EPERMIT Desc		2020



Accessory Dwelling Units

Index # - File Name: 1.0022 - Single Family Dwellings Data\_Snohomish County.pdf

New	Application Expiration date extended 120 days per Emergency Ordinance 20-027	EPERMIT Desc	2020
New	Expiration date extended 120 days per Emergency Ordinance 20-027	EPERMIT Description of W	2020
New	Application Expiration date extended 120 days per Emergency Ordinance 20-027	EPERMIT Desc	2020
New	Expiration date extended 120 days per Emergency Ordinance 20-027	EPERMIT Description of W	2020
New	Application Expiration date extended 120 days per Emergency Ordinance 20-027	EPERMIT Desc	2020
New	Application Expiration date extended 120 days per Emergency Ordinance 20-027	EPERMIT Desc	2020
New	Application Expiration date extended 120 days per Emergency Ordinance 20-027	EPERMIT Desc	2020
New	Application Expiration date extended 120 days per Emergency Ordinance 20-027	EPERMIT Desc	2020
New	Application Expiration date extended 120 days per Emergency Ordinance 20-027	EPERMIT Desc	2020
New	Expiration date extended 120 days per Emergency Ordinance 20-027	Approved basic 20-100868	2020
New	Expiration date extended 120 days per Emergency Ordinance 20-027	Approved basic 16-113271	2020
New	Application Expiration date extended 120 days per Emergency Ordinance 20-027	Approved Basi	2020
New	Application Expiration date extended 120 days per Emergency Ordinance 20-027	Approved basi	2020
New	Application Expiration date extended 120 days per Emergency Ordinance 20-027	Approved basi	2020
New	Application Expiration date extended 120 days per Emergency Ordinance 20-027	Approved bas	2020
New	Application Expiration date extended 120 days per Emergency Ordinance 20-027	Approved Basi	2020
New	Expiration date extended 120 days per Emergency Ordinance 20-027	Approved basic 19-108708	2020
New	Expiration date extended 120 days per Emergency Ordinance 20-027	Approved Basic 18-122140	2020
New	Approved basic 19-113524 BP	2015 IRC Plan 2175-02 ABC v3 (garage revision) 2174 sf 3-s	2020
New	Approved Basic 18-120927BP	IRC: 2015 PLAN: 2210EF 2210sf three story SFR wit	2020
New	Approved Basic 17-118650 BP	2015 IRC PLAN: 2431 AB 2431sf three story S	2020
New	Approved Basic 18-120929BP	2015 IRC PLAN: 2418ABC v 2 2418sf three story	2020
New	Approved basic 19-101581 BP	2015 IRC Plan# 2431 ABC 2015 IRC v2 3-story sfr w	2020
New	Approved basic 19-113524 BP	2015 IRC Plan 2175-02 ABC v3 (garage revision) 2174 sf 3-s	2020
New	Approved Basic 17-118650 BP	2015 IRC PLAN: 2431 AB 2431sf three story S	2020
New	Approved basic 19-113524 BP	2015 IRC Plan 2175-02 ABC v3 (garage revision) 2174 sf 3-s	2020
New	Approved Basic 18-120929BP	2015 IRC PLAN: 2418ABC v 2 2418sf three story	2020
New	Approved Basic 17-118650 BP	2015 IRC PLAN: 2431 AB 2431sf three story S	2020
New	Approved basic 19-113524 BP	2015 IRC Plan 2175-02 ABC v3 (garage revision) 2174 sf 3-s	2020
New	EPERMIT Description of Work: Installation of a manufactured home and driveway/parking with :		2020
New	Approved Basic 17-106927 BP	2015 IRC Plan# 3019 3019sf two story SFR	2020
New	Approved Basic 17-111515 BP	2015 IRC PLAN: 2972-38# 2972sf two story SFI	2020
New	Approved Basic 17 114919 BP	2015 IRC 2578 SQ Ft. SFR with attached garage.	2020
New	Approved Basic 17-111513 BP	IRC 2015 PLAN: 2458-38# 2458sf rambler with	2020
New	Approved Basic 17 114919 BP	2015 IRC 2578 SQ Ft. SFR with attached garage.	2020
New	Approved Basic 17-111513 BP	IRC 2015 PLAN: 2458-38# 2458sf rambler with	2020
New	Approved basic 19-114674 BP	2015 IRC Plan# 2112 - 38# Rambler style SFR w/attach	2020
New	Approved basic 19-115385 BP	Plan# 2450 - 38# 2-story SFR w/attached garage	2020
New	Approved basic 19-101582 BP	2015 IRC Plan# 704 2-story SFR w/attached garage, 2nd floor p	2020
New	Approved basic 19-101591 BP	2015 IRC Plan# 707 2-story sfr w/attached garag	2020
New	Approved basic 19-101590 BP	2015 IRC Plan# 705 2-story SFR w/attached garage	2020
New	Approved basic 19-101591 BP	2015 IRC Plan# 707 2-story sfr w/attached garag	2020
New	Approved basic 19-101582 BP	2015 IRC Plan# 704 2-story sfr w/attached gar	2020
New	Approved basic 20-100001 BP	2015 IRC Plan 2041 2-story duplex w/attached garage	2020
New	Approved Basic 18-117375BP	2015IRC PLAN: 2441 2441sf two story SFR with	2020
New	Approved Basic 18-117375BP	2015IRC PLAN: 2441 2441sf two story SFR with	2020
New	Approved Basic 17-118650 BP	2015 IRC PLAN: 2431 AB 2431sf three story S	2020

Accessory Dwelling Units

Index # - File Name: 1.0022 - Single Family Dwellings Data\_Snohomish County.pdf

New	Approved basic 19-113524 BP	2015 IRC	Plan 2175-02 ABC v3 (garage revision)	2174 sf 3-s	2020
New	Approved Basic 17-118650 BP	2015 IRC	PLAN: 2431 AB	2431sf three story S	2020
New	Approved Basic 18-120929BP	2015 IRC	PLAN: 2418ABC v 2	2418sf three story	2020
New	Approved Basic 18-120929BP	2015 IRC	PLAN: 2418 ABC v 2	2418sf three stor	2020
New	Application Expiration date extended 120 days per Emergency Ordinance 20-027	Approved basi			2020
New	Expiration date extended 120 days per Emergency Ordinance 20-027	Approved Basic 18-120929			2020
New	Expiration date extended 120 days per Emergency Ordinance 20-027	Approved Basic 18-12332!			2020
New	Expiration date extended 120 days per Emergency Ordinance 20-027	Approved Basic 18-12332!			2020
New	Application Expiration date extended 120 days per Emergency Ordinance 20-027	Approved Bas			2020
New	Application Expiration date extended 120 days per Emergency Ordinance 20-027	Approved Bas			2020
New	Application Expiration date extended 120 days per Emergency Ordinance 20-027	Approved Basi			2020
New	Application Expiration date extended 120 days per Emergency Ordinance 20-027	Approved basi			2020
New	Approved Basic 18-120929BP	2015 IRC	PLAN: 2418ABC v 2	2418sf three story	2020
New	Approved Basic 18-120929BP	2015 IRC	PLAN: 2418 ABC v 2	2418sf three stor	2020
New	Approved Basic 18-120929BP	2015 IRC	PLAN: 2418ABC v 2	2418sf three story	2020
New	Approved basic 19-113524 BP	2015 IRC	Plan 2175-02 ABC v3 (garage revision)	2174 sf 3-s	2020
New	Approved Basic 17-118650 BP	2015 IRC	PLAN: 2431 AB	2431sf three story S	2020
New	Approved Basic 17-118650 BP	2015 IRC	PLAN: 2431 AB	2431sf three story S	2020
New	Application Expiration date extended 120 days per Emergency Ordinance 20-027	Approved basi			2020
New	Expiration date extended 120 days per Emergency Ordinance 20-027	Approved Basic 18-120929			2020
New	Expiration date extended 120 days per Emergency Ordinance 20-027	Approved basic 19-113524			2020
New	EPERMIT Description of Work: Construct new SFR in Glenmore Phase 3				2020
New	EPERMIT Description of Work: Construct new SFR in Glenmore Phase 3A				2020
New	EPERMIT Description of Work: Construct new SFR in Glenmore phase 3A				2020
New	EPERMIT Description of Work: New Construction of single family residence				2020
New	EPERMIT Description of Work: Construct new SFR in Glenmore Phase 3A				2020
New	EPERMIT Description of Work: Construct new SFR in Glenmore phase 3.				2020
New	EPERMIT Description of Work: Construct new SFR in Glenmore Phase 3B				2020
New	EPERMIT Description of Work: Construction of single family residence				2020
New	EPERMIT Description of Work: construct new single family residence				2020
New	Application Expiration date extended 120 days per Emergency Ordinance 20-027	EPERMIT Desc			2020
New	Application Expiration date extended 120 days per Emergency Ordinance 20-027	EPERMIT Desc			2020
New	Expiration date extended 120 days per Emergency Ordinance 20-027	EPERMIT: Construction of			2020
New	Expiration date extended 120 days per Emergency Ordinance 20-027	Approved basic 18-151506			2020
New	Expiration date extended 120 days per Emergency Ordinance 20-027	Approved Basic 17-107067			2020
New	Expiration date extended 120 days per Emergency Ordinance 20-027	Approved basic 18-151506			2020
New	Expiration date extended 120 days per Emergency Ordinance 20-027	Approved Basic 17-107067			2020
New	Application Expiration date extended 120 days per Emergency Ordinance 20-027	Approved basi			2020
New	Expiration date extended 120 days per Emergency Ordinance 20-027	EPERMIT Description of W			2020
New	Expiration date extended 120 days per Emergency Ordinance 20-027	EPERMIT: Residential builc			2020
New	Application Expiration date extended 120 days per Emergency Ordinance 20-027	Approved basi			2020
New	Application Expiration date extended 120 days per Emergency Ordinance 20-027	Approved basi			2020
New	Application Expiration date extended 120 days per Emergency Ordinance 20-027	Approved basi			2020
New	Approved basic 19-117615 BP	2015 IRC	Plan# 2311 B GLR	2-story SFR w/attached ga	2020
New	Approved basic 19-114561 BP	2015 IRC	Plan 3017 A GLR	2-story SFR w/attached gara	2020
New	Approved basic 19-117615 BP	2015 IRC	Plan# 2311 B GLR	2-story sfr w/attached gara	2020
New	Approved basic 19-117617 BP	2015 IRC	Plan 2989 C GLR	2-story SFR w/attached garag	2020

Accessory Dwelling Units

Index # - File Name: 1.0022 - Single Family Dwellings Data\_Snohomish County.pdf

New	Approved basic 19-117616BP	2015 IRC	Plan# 2501 B GLR	2-story sfr w/attached	2020
New	Approved basic 19-114553 BP	2015 IRC	Plan# 2311 A GLR	2-story sfr w/attached ga	2020
New	Application Expiration date extended 120 days per Emergency Ordinance 20-027 Approved basi				2020
New	Application Expiration date extended 120 days per Emergency Ordinance 20-027 Approved basi				2020
New	Application Expiration date extended 120 days per Emergency Ordinance 20-027 Approved basi				2020
New	Expiration date extended 120 days per Emergency Ordinance 20-027 Approved basic 19-117616				2020
New	Expiration date extended 120 days per Emergency Ordinance 20-027 Approved basic 19-112613				2020
New	Application Expiration date extended 120 days per Emergency Ordinance 20-027 Approved basi				2020
New	Application Expiration date extended 120 days per Emergency Ordinance 20-027 Approved Basi				2020
New	Application Expiration date extended 120 days per Emergency Ordinance 20-027 Approved Basi				2020
New	Expiration date extended 120 days per Emergency Ordinance 20-027 Approved basic 18-151506				2020
New	Expiration date extended 120 days per Emergency Ordinance 20-027 Approved Basic 17-107067				2020
New	Expiration date extended 120 days per Emergency Ordinance 20-027 Approved Basic 17-107067				2020
New	Expiration date extended 120 days per Emergency Ordinance 20-027 Approved Basic 17 114855				2020
New	Expiration date extended 120 days per Emergency Ordinance 20-027 Approved basic 19-103979				2020
New	Expiration date extended 120 days per Emergency Ordinance 20-027 Approved basic 19-103750				2020
New	Expiration date extended 120 days per Emergency Ordinance 20-027 Approved basic 19-103750				2020
New	Expiration date extended 120 days per Emergency Ordinance 20-027 Approved Basic 17 114855				2020
New	Application Expiration date extended 120 days per Emergency Ordinance 20-027 Approved basi				2020
New	Application Expiration date extended 120 days per Emergency Ordinance 20-027 Approved Basi				2020
New	Application Expiration date extended 120 days per Emergency Ordinance 20-027 Approved basi				2020
New	Application Expiration date extended 120 days per Emergency Ordinance 20-027 Approved basi				2020
New	Expiration date extended 120 days per Emergency Ordinance 20-027 Approved basic 20-101716				2020
New	Expiration date extended 120 days per Emergency Ordinance 20-027 Approved basic 20-101722				2020
New	Application Expiration date extended 120 days per Emergency Ordinance 20-027 Approved basi				2020
New	Approved basic 20-101717 BP	2015 IRC	Plan# 3724-A	2-story SFR w/attached garage	2020
New	Approved basic 20-101711 BP	2015 IRC	Plan 3706-A	2 story sfr w/attached garag	2020
New	Approved basic 20-101715 BP	2015 IRC	Plan# 3729-B	2-story SFR w/attached garage	2020
New	Approved basic 20-101722 BP	2015 IRC	Plan# 3724-B	2-story SFR w/attached garage	2020
New	Approved basic 20-101718 BP	2015 IRC	Plan 3760-B	2 story sfr w/attached garag	2020
New	Approved basic 20-101716 BP	2015 IRC	Plan# 3729-A	2-story SFR w/attached garage	2020
New	Approved basic 20-101717 BP	2015 IRC	Plan# 3724-A	2-story SFR w/attached garage	2020
New	Application Expiration date extended 120 days per Emergency Ordinance 20-027 Approved basi				2020
New	Expiration date extended 120 days per Emergency Ordinance 20-027 Approved basic 20-101722				2020
New	Expiration date extended 120 days per Emergency Ordinance 20-027 Approved basic 20-101716				2020
New	Expiration date extended 120 days per Emergency Ordinance 20-027 Approved basic 20-101711				2020
New	Expiration date extended 120 days per Emergency Ordinance 20-027 Approved basic 20-101717				2020
New	Expiration date extended 120 days per Emergency Ordinance 20-027 Approved basic 20-101715				2020
New	Application Expiration date extended 120 days per Emergency Ordinance 20-027 Approved basi				2020
New	Approved basic 20-101716 BP	2015 IRC	Plan# 3729-A	2-story SFR w/attached garage	2020
New	Approved basic 20-101717 BP	2015 IRC	Plan# 3724-A	2-story SFR w/attached garage	2020
New	Approved basic 20-101711 BP	2015 IRC	Plan 3706-A	2 story sfr w/attached garag	2020
New	Approved basic 20-101718 BP	2015 IRC	Plan 3760-B	2 story sfr w/attached garag	2020
New	Approved basic 20-101722 BP	2015 IRC	Plan# 3724-B	2-story SFR w/attached garage	2020
New	Approved basic 20-101711 BP	2015 IRC	Plan 3706-A	2 story sfr w/attached garag	2020
New	Application Expiration date extended 120 days per Emergency Ordinance 20-027 Approved basi				2020

Accessory Dwelling Units

Index # - File Name: 1.0022 - Single Family Dwellings Data\_Snohomish County.pdf

New	Expiration date extended 120 days per Emergency Ordinance 20-027 Approved basic 20-101711	2020
New	Approved Basic 17 114855BP 2015 IRC Plan 2353AB 2353 Sq Ft Single Family Re:	2020
New	Application Expiration date extended 120 days per Emergency Ordinance 20-027 Approved Basi	2020
New	Application Expiration date extended 120 days per Emergency Ordinance 20-027 Approved basi	2020
New	Application Expiration date extended 120 days per Emergency Ordinance 20-027 Approved Basi	2020
New	Application Expiration date extended 120 days per Emergency Ordinance 20-027 Approved Basi	2020
New	Application Expiration date extended 120 days per Emergency Ordinance 20-027 Approved Basi	2020
New	Expiration date extended 120 days per Emergency Ordinance 20-027 EPERMIT Description of W	2020
New	Application Expiration date extended 120 days per Emergency Ordinance 20-027 EPERMIT Desc	2020
New	Application Expiration date extended 120 days per Emergency Ordinance 20-027 EPERMIT Desc	2020
New	Expiration date extended 120 days per Emergency Ordinance 20-027 EPERMIT Description of W	2020
New	Expiration date extended 120 days per Emergency Ordinance 20-027 EPERMIT Description of W	2020
New	Expiration date extended 120 days per Emergency Ordinance 20-027 EPERMIT Description of W	2020
New	Expiration date extended 120 days per Emergency Ordinance 20-027 EPERMIT Description of W	2020
New	Expiration date extended 120 days per Emergency Ordinance 20-027 Approved Basic 18-12621:	2020
New	Approved basic 19-111423 BP 2015 IRC Plan 2049 2049 sf rambler w/attached garage Pla	2020
New	Approved basic 19-111424 BP 2015 IRC Plan 2218 2218 sf rambler w/attached garage Pla	2020
New	Expiration date extended 120 days per Emergency Ordinance 20-027 Approved Basic 18-124947	2020
New	Application Expiration date extended 120 days per Emergency Ordinance 20-027 EPERMIT Desc	2020
New	Expiration date extended 120 days per Emergency Ordinance 20-027 EPERMIT Description of W	2020
New	EPERMIT Description of Work: Build SFR	2020
New	Expiration date extended 120 days per Emergency Ordinance 20-027 EPERMIT Description of W	2020
New	Expiration date extended 120 days per Emergency Ordinance 20-027 EPERMIT Description of W	2020
New	Application Expiration date extended 120 days per Emergency Ordinance 20-027 EPERMIT Desc	2020
New	Expiration date extended 120 days per Emergency Ordinance 20-027 Approved basic 19-111423	2020
New	Expiration date extended 120 days per Emergency Ordinance 20-027 Approved basic 19-111424	2020
New	Expiration date extended 120 days per Emergency Ordinance 20-027 Approved basic 19-111422	2020
New	Approved basic 19-111423 BP 2015 IRC Plan 2049 2049 sf rambler w/attached garage	2020
New	Approved basic 19-111423 BP 2015 IRC Plan 2049 2049 sf rambler w/attached garage	2020
New	Expiration date extended 120 days per Emergency Ordinance 20-027 Approved basic 19-103675	2020
New	Expiration date extended 120 days per Emergency Ordinance 20-027 Approved basic 19-103678	2020
New	Expiration date extended 120 days per Emergency Ordinance 20-027 Approved basic 19-103675	2020
New	Expiration date extended 120 days per Emergency Ordinance 20-027 Approved basic 16-10824:	2020
New	Expiration date extended 120 days per Emergency Ordinance 20-027 Approved basic 19-103677	2020
New	Expiration date extended 120 days per Emergency Ordinance 20-027 Approved basic 19-106717	2020
New	Expiration date extended 120 days per Emergency Ordinance 20-027 Approved basic 19-107966	2020
New	Expiration date extended 120 days per Emergency Ordinance 20-027 Approved basic 19-107974	2020
New	Expiration date extended 120 days per Emergency Ordinance 20-027 Approved basic 16-116037	2020
New	Expiration date extended 120 days per Emergency Ordinance 20-027 Approved basic 19-108735	2020
New	Expiration date extended 120 days per Emergency Ordinance 20-027 Approved basic 19-108704	2020
New	Expiration date extended 120 days per Emergency Ordinance 20-027 EPERMIT Description of W	2020
New	Expiration date extended 120 days per Emergency Ordinance 20-027 Approved basic 19-107966	2020
New	Expiration date extended 120 days per Emergency Ordinance 20-027 Approved basic 19-106717	2020
New	Expiration date extended 120 days per Emergency Ordinance 20-027 Approved Basic 18118272	2020
New	Expiration date extended 120 days per Emergency Ordinance 20-027 Approved basic 19-107966	2020
New	Expiration date extended 120 days per Emergency Ordinance 20-027 Approved basic 19-106717	2020
New	Expiration date extended 120 days per Emergency Ordinance 20-027 Approved Basic 18 116039	2020

Accessory Dwelling Units

Index # - File Name: 1.0022 - Single Family Dwellings Data\_Snohomish County.pdf

New	Expiration date extended 120 days per Emergency Ordinance 20-027 Approved Basic 18-124980	2020
New	Expiration date extended 120 days per Emergency Ordinance 20-027 Approved basic 19-106209	2020
New	Application Expiration date extended 120 days per Emergency Ordinance 20-027 EPERMIT: Built	2020
New	Application Expiration date extended 120 days per Emergency Ordinance 20-027 EPERMIT Desc	2020
New	Application Expiration date extended 120 days per Emergency Ordinance 20-027 EPERMIT Desc	2020
New	EPERMIT Description of Work: Building a new single family residence	2020
New	Expiration date extended 120 days per Emergency Ordinance 20-027 EPERMIT Description of W	2020
New	Expiration date extended 120 days per Emergency Ordinance 20-027 EPERMIT Description of W	2020
New	Expiration date extended 120 days per Emergency Ordinance 20-027 EPERMIT Description of W	2020
New	Expiration date extended 120 days per Emergency Ordinance 20-027 EPERMIT Description of W	2020
New	Expiration date extended 120 days per Emergency Ordinance 20-027 EPERMIT Description of W	2020
New	Expiration date extended 120 days per Emergency Ordinance 20-027 EPERMIT Description of W	2020
New	Expiration date extended 120 days per Emergency Ordinance 20-027 EPERMIT Description of W	2020
New	Application Expiration date extended 120 days per Emergency Ordinance 20-027 EPERMIT Desc	2020
New	EPERMIT Description of Work: Construct new SFDU	2020
New	EPERMIT Description of Work: Construct new SFDU	2020
New	EPERMIT Description of Work: Construct new SFDU (Unit 14, Ash Way SFDU)	2020
New	EPERMIT Description of Work: Construct new SFDU	2020
New	EPERMIT Description of Work: Construct new SFDU	2020
New	EPERMIT Description of Work: Construct new SFDU	2020
New	EPERMIT Description of Work: Construct new SFDU	2020
New	EPERMIT Description of Work: Construct new SFDU	2020
New	Expiration date extended 120 days per Emergency Ordinance 20-027 EPERMIT: installing a new	2020
New	Expiration date extended 120 days per Emergency Ordinance 20-027 Approved Basic 18118272	2020
New	Expiration date extended 120 days per Emergency Ordinance 20-027 Approved basic 19-108708	2020
New	Expiration date extended 120 days per Emergency Ordinance 20-027 Approved Basic 18 116043	2020
New	Expiration date extended 120 days per Emergency Ordinance 20-027 Approved basic 19-108708	2020
New	Expiration date extended 120 days per Emergency Ordinance 20-027 Approved Basic 18118272	2020
New	Expiration date extended 120 days per Emergency Ordinance 20-027 Approved basic 19-106718	2020
New	Expiration date extended 120 days per Emergency Ordinance 20-027 Approved Basic 18 116039	2020
New	Expiration date extended 120 days per Emergency Ordinance 20-027 Approved basic 19-107974	2020
New	Expiration date extended 120 days per Emergency Ordinance 20-027 Approved Basic 18118272	2020
New	Expiration date extended 120 days per Emergency Ordinance 20-027 Approved Basic 18 116043	2020
New	Expiration date extended 120 days per Emergency Ordinance 20-027 Approved Basic 18-12498	2020
New	Expiration date extended 120 days per Emergency Ordinance 20-027 Approved basic 19-106257	2020
New	Expiration date extended 120 days per Emergency Ordinance 20-027 EPERMIT Description of W	2020
New	Expiration date extended 120 days per Emergency Ordinance 20-027 EPERMIT Description of W	2020
New	Expiration date extended 120 days per Emergency Ordinance 20-027 Approved basic 19-103677	2020
New	Expiration date extended 120 days per Emergency Ordinance 20-027 Approved basic 20-101145	2020
New	Expiration date extended 120 days per Emergency Ordinance 20-027 Approved basic 16-120708	2020
New	EPERMIT Description of Work: Construct new SFR in Glenmore Phase 4	2020
New	5/19/20 cst Airpark Disclosure Notice AFN 202005150970 EPERMIT Description of Work: Constr	2020
New	Application Expiration date extended 120 days per Emergency Ordinance 20-027 EPERMIT Desc	2020
New	Airport Disclosure AFN 202006040101 EPERMIT Description of Work: Construct new SFR in Gler	2020
New	EPERMIT Description of Work: Construct new SFR in Glenmore Phase 4	2020
New	Expiration date extended 120 days per Emergency Ordinance 20-027 EPERMIT Description of W	2020

Accessory Dwelling Units

Index # - File Name: 1.0022 - Single Family Dwellings Data\_Snohomish County.pdf

New	Expiration date extended 120 days per Emergency Ordinance 20-027 EPERMIT Description of W	2020
New	Expiration date extended 120 days per Emergency Ordinance 20-027 EPERMIT Description of W	2020
New	***07/27/2020 DJL- Fees posted to MBP*** Expiration date extended 120 days per Emergency	2020
New	Expiration date extended 120 days per Emergency Ordinance 20-027 Approved basic 19-103667	2020
New	Expiration date extended 120 days per Emergency Ordinance 20-027 Approved basic 19-10367	2020
New	Expiration date extended 120 days per Emergency Ordinance 20-027 Approved Basic 18118272	2020
New	Expiration date extended 120 days per Emergency Ordinance 20-027 Approved basic 19-103678	2020
New	Expiration date extended 120 days per Emergency Ordinance 20-027 Approved basic 19-103677	2020
New	Expiration date extended 120 days per Emergency Ordinance 20-027 Approved basic 19-108704	2020
New	Expiration date extended 120 days per Emergency Ordinance 20-027 Approved Basic 18 116043	2020
New	Expiration date extended 120 days per Emergency Ordinance 20-027 Approved basic 19-103675	2020
New	Expiration date extended 120 days per Emergency Ordinance 20-027 Approved basic 19-103664	2020
New	Expiration date extended 120 days per Emergency Ordinance 20-027 Approved Basic 18118272	2020
New	Expiration date extended 120 days per Emergency Ordinance 20-027 Approved basic 19-10367	2020
New	Approved Basic 18 116043BP 2015 irc Trafton 2-D 2410 Sq ft 4 bedroom with attached	2020
New	Approved basic 19-108708 BP 2015 IRC Olympic Plan C/D Elevation 2-story SFR w/attached	2020
New	Expiration date extended 120 days per Emergency Ordinance 20-027 Approved basic 19-108735	2020
New	Expiration date extended 120 days per Emergency Ordinance 20-027 Approved Basic 18-118943	2020
New	Approved Basic 18-118943BP 2015 IRC PLAN: Baker 2 2682sf two story SFR with	2020
New	Approved basic 19-108708 BP 2015 IRC Olympic Plan C/D Elev 2-story SFR w/attached gara	2020
New	Expiration date extended 120 days per Emergency Ordinance 20-027 Approved basic 19-108704	2020
New	Approved Basic 18 116039BP 2015 irc Trafton 2-C 2410 Sq ft 4 bedroom with attached	2020
New	Approved basic 19-103671 BP 2015 IRC Plan: Lennon C D 2-story SFR w/attached garage	2020
New	Approved basic 19-103675 BP 2015 IRC Plan: Shannon C D 2-story SFR w/attached garag	2020
New	Approved Basic 18118272 BP 2015 IRC Plan# Kimball 2 C D 2-story SFR w/attache	2020
New	Approved basic 19-103678 BP 2015 IRC Plan: Hudson C D 2-story SFR w/attached garage	2020
New	Approved basic 16-113276 BP 2015 IRC Plan# Chelan II C 2-story SFR w/attache	2020
New	Approved Basic 18-118943BP 2015 IRC PLAN: Baker 2 2682sf two story SFR with	2020
New	Approved basic 19-103677 BP 2015 IRC Plan: Thelon C D 2-story SFR w/attached garage	2020
New	Expiration date extended 120 days per Emergency Ordinance 20-027 Approved basic 19-103678	2020
New	Expiration date extended 120 days per Emergency Ordinance 20-027 Approved Basic 18118272	2020
New	Expiration date extended 120 days per Emergency Ordinance 20-027 Approved basic 19-10367	2020
New	Expiration date extended 120 days per Emergency Ordinance 20-027 Approved basic 19-103664	2020
New	Expiration date extended 120 days per Emergency Ordinance 20-027 Approved basic 19-103675	2020
New	Expiration date extended 120 days per Emergency Ordinance 20-027 Approved basic 19-103677	2020
New	Expiration date extended 120 days per Emergency Ordinance 20-027 Approved basic 19-108708	2020
New	Expiration date extended 120 days per Emergency Ordinance 20-027 Approved basic 19-108708	2020
New	Approved Basic 18-124981BP 2015 IRC PLAN: Baker 2 C/D Daylight 3513sf three sto	2020
New	Expiration date extended 120 days per Emergency Ordinance 20-027 Approved basic 19-106054	2020
New	Expiration date extended 120 days per Emergency Ordinance 20-027 Approved Basic 18-12498	2020
New	Approved basic 19-102410 BP 2015 IRC Plan 2766 ABC (35# snow load) 2766sf ran	2020
New	Approved basic 16-120708 BP 2015 IRC Plan# 3484 2-story sfr w/attache	2020
New	Approved basic 19-102410 BP 2015 IRC Plan 2766 ABC (35# snow load) 2766sf ran	2020
New	Approved basic 19-102410 BP 2015 IRC Plan 2766 ABC (35# snow load) 2766sf ran	2020
New	Application Expiration date extended 120 days per Emergency Ordinance 20-027 EPERMIT Desc	2020
New	Application Expiration date extended 120 days per Emergency Ordinance 20-027 Approved basi	2020
New	Approved basic 16-120708 BP 2015 IRC Plan# 3484 2-story sfr w/attache	2020

Accessory Dwelling Units

Index # - File Name: 1.0022 - Single Family Dwellings Data\_Snohomish County.pdf

New	Approved Basic 18-151365BP	2015 IRC	PLAN: 2402 35# Snow Load	2402sf single st	2020
New	Expiration date extended 120 days per Emergency Ordinance 20-027	EPERMIT	Description of W		2020
New	Expiration date extended 120 days per Emergency Ordinance 20-027	Approved basic 17-100648			2020
New	Expiration date extended 120 days per Emergency Ordinance 20-027	Approved basic 19-106321			2020
New	Expiration date extended 120 days per Emergency Ordinance 20-027	Approved basic 17-100648			2020
New	Expiration date extended 120 days per Emergency Ordinance 20-027	EPERMIT	Description of W		2020
New	Expiration date extended 120 days per Emergency Ordinance 20-027	EPERMIT	Description of W		2020
New	Expiration date extended 120 days per Emergency Ordinance 20-027	EPERMIT	Description of W		2020
New	Application Expiration date extended 120 days per Emergency Ordinance 20-027	EPERMIT: New			2020
New	Application Expiration date extended 120 days per Emergency Ordinance 20-027	Approved basi			2020
New	Application Expiration date extended 120 days per Emergency Ordinance 20-027	Approved basi			2020
New	Expiration date extended 120 days per Emergency Ordinance 20-027	Approved Basic 18118272			2020
New	Expiration date extended 120 days per Emergency Ordinance 20-027	Approved Basic 18118272			2020
New	Expiration date extended 120 days per Emergency Ordinance 20-027	Approved Basic 18 116039			2020
New	Expiration date extended 120 days per Emergency Ordinance 20-027	Approved Basic 18118272			2020
New	Expiration date extended 120 days per Emergency Ordinance 20-027	Approved Basic 16-113032			2020
New	Expiration date extended 120 days per Emergency Ordinance 20-027	Approved Basic 18 116043			2020
New	Expiration date extended 120 days per Emergency Ordinance 20-027	Approved basic 16-113033			2020
New	Application Expiration date extended 120 days per Emergency Ordinance 20-027	Approved basi			2020
New	Application Expiration date extended 120 days per Emergency Ordinance 20-027	Approved basi			2020
New	Expiration date extended 120 days per Emergency Ordinance 20-027	Approved basic 19-102410			2020
New	Application Expiration date extended 120 days per Emergency Ordinance 20-027	Approved basi			2020
New	Expiration date extended 120 days per Emergency Ordinance 20-027	Approved Basic 18-15136			2020
New	Application Expiration date extended 120 days per Emergency Ordinance 20-027	EPERMIT Desc			2020
New	Expiration date extended 120 days per Emergency Ordinance 20-027	EPERMIT	Description of W		2020
New	EPERMIT Description of Work: New single family residence	RELATED 20-105368	LDA		2020
New	Expiration date extended 120 days per Emergency Ordinance 20-027	Approved basic 19-109118			2020
New	Expiration date extended 120 days per Emergency Ordinance 20-027	Approved basic 19-109174			2020
New	Application Expiration date extended 120 days per Emergency Ordinance 20-027	EPERMIT Desc			2020
New	Expiration date extended 120 days per Emergency Ordinance 20-027	Approved basic 19-109201			2020
New	Expiration date extended 120 days per Emergency Ordinance 20-027	EPERMIT	Description of W		2020
New	Expiration date extended 120 days per Emergency Ordinance 20-027	EPERMIT: Construction of			2020
New	Expiration date extended 120 days per Emergency Ordinance 20-027	Approved basic 19-109118			2020
New	Application Expiration date extended 120 days per Emergency Ordinance 20-027	Approved Basi			2020
New	Expiration date extended 120 days per Emergency Ordinance 20-027	EPERMIT	Description of W		2020
New	Application Expiration date extended 120 days per Emergency Ordinance 20-027	EPERMIT Desc			2020
New	Expiration date extended 120 days per Emergency Ordinance 20-027	Approved basic 16-114982			2020
New	Application Expiration date extended 120 days per Emergency Ordinance 20-027	Approved basi			2020
New	Application Expiration date extended 120 days per Emergency Ordinance 20-027	Approved basi			2020
New	Approved basic 20-108192 BP	2015 IRC	Plan# Juneau	2-story SFR w/attached garage	2020
New	Approved basic 20-102812 BP	2015 IRC	Plan: Helena	Rambler w/attached garage This p	2020
New	Application Expiration date extended 120 days per Emergency Ordinance 20-027	Approved basi			2020
New	Expiration date extended 120 days per Emergency Ordinance 20-027	EPERMIT	Description of W		2020
New	Expiration date extended 120 days per Emergency Ordinance 20-027	EPERMIT	Description of W		2020
New	Expiration date extended 120 days per Emergency Ordinance 20-027	EPERMIT	Description of W		2020
New	Application Expiration date extended 120 days per Emergency Ordinance 20-027	EPERMIT Desc			2020
New	EPERMIT Description of Work: We are building a single family residence for our family.				2020

Accessory Dwelling Units

Index # - File Name: 1.0022 - Single Family Dwellings Data\_Snohomish County.pdf

New	Expiration date extended 120 days per Emergency Ordinance 20-027 EPERMIT Description of W	2020
New	Expiration date extended 120 days per Emergency Ordinance 20-027 EPERMIT Description of W	2020
New	Application Expiration date extended 120 days per Emergency Ordinance 20-027 EPERMIT Desc	2020
New	Application Expiration date extended 120 days per Emergency Ordinance 20-027 EPERMIT Desc	2020
New	Application Expiration date extended 120 days per Emergency Ordinance 20-027 EPERMIT Desc	2020
New	Application Expiration date extended 120 days per Emergency Ordinance 20-027 EPERMIT Desc	2020
New	Application Expiration date extended 120 days per Emergency Ordinance 20-027 New 3 story 36	2020
New	Application Expiration date extended 120 days per Emergency Ordinance 20-027 EPERMIT Desc	2020
New	Application Expiration date extended 120 days per Emergency Ordinance 20-027 EPERMIT Desc	2020
New	Application Expiration date extended 120 days per Emergency Ordinance 20-027 EPERMIT Desc	2020
New	Application Expiration date extended 120 days per Emergency Ordinance 20-027	2020
New	Application Expiration date extended 120 days per Emergency Ordinance 20-027 Approved basi	2020
New	Expiration date extended 120 days per Emergency Ordinance 20-027 Approved basic 16-120708	2020
New	Expiration date extended 120 days per Emergency Ordinance 20-027 Approved basic 19-102410	2020
New	Application Expiration date extended 120 days per Emergency Ordinance 20-027 Approved basi	2020
New	Expiration date extended 120 days per Emergency Ordinance 20-027 Approved Basic 17 119907	2020
New	Approved basic 19-102410 BP 2015 IRC Plan 2766 ABC (35# snow load) 2766sf ran	2020
New	Application Expiration date extended 120 days per Emergency Ordinance 20-027 EPERMIT Desc	2020
New	Expiration date extended 120 days per Emergency Ordinance 20-027 Approved Basic 17-119362	2020
New	Expiration date extended 120 days per Emergency Ordinance 20-027 Approved Basic 18-120927	2020
New	Expiration date extended 120 days per Emergency Ordinance 20-027 Approved Basic 18-120929	2020
New	Expiration date extended 120 days per Emergency Ordinance 20-027 Approved Basic 17-119362	2020
New	Expiration date extended 120 days per Emergency Ordinance 20-027 EPERMIT Description of W	2020
New	Expiration date extended 120 days per Emergency Ordinance 20-027 Approved basic 16-114982	2020
New	Application Expiration date extended 120 days per Emergency Ordinance 20-027 EPERMIT Desc	2020
New	Expiration date extended 120 days per Emergency Ordinance 20-027 Approved basic 16-114982	2020
New	Expiration date extended 120 days per Emergency Ordinance 20-027 Approved basic 16-114982	2020
New	Expiration date extended 120 days per Emergency Ordinance 20-027 Approved basic 16-114982	2020
New	Expiration date extended 120 days per Emergency Ordinance 20-027 Approved basic 16-114982	2020
New	Expiration date extended 120 days per Emergency Ordinance 20-027 Approved basic 16-114982	2020
New	Expiration date extended 120 days per Emergency Ordinance 20-027 Convert sales office to gar	2020
New	Application Expiration date extended 120 days per Emergency Ordinance 20-027 Approved basi	2020
New	Application Expiration date extended 120 days per Emergency Ordinance 20-027 Approved basi	2020
New	Application Expiration date extended 120 days per Emergency Ordinance 20-027 Approved basi	2020
New	Application Expiration date extended 120 days per Emergency Ordinance 20-027 Approved basi	2020
New	Expiration date extended 120 days per Emergency Ordinance 20-027 EPERMIT Description of W	2020
New	Expiration date extended 120 days per Emergency Ordinance 20-027 EPERMIT Description of W	2020
New	Application Expiration date extended 120 days per Emergency Ordinance 20-027 EPERMIT Desc	2020
New	Expiration date extended 120 days per Emergency Ordinance 20-027 EPERMIT Description of W	2020
New	Application Expiration date extended 120 days per Emergency Ordinance 20-027 EPERMIT Desc	2020
New	Expiration date extended 120 days per Emergency Ordinance 20-027 Approved Basic 18-120929	2020
New	Expiration date extended 120 days per Emergency Ordinance 20-027 Approved basic 19-103675	2020
New	Expiration date extended 120 days per Emergency Ordinance 20-027 Approved basic 19-103677	2020
New	Expiration date extended 120 days per Emergency Ordinance 20-027 Approved basic 16-114982	2020
New	Application Expiration date extended 120 days per Emergency Ordinance 20-027 EPERMIT Desc	2020
New	Application Expiration date extended 120 days per Emergency Ordinance 20-027 EPERMIT Desc	2020
New	Application Expiration date extended 120 days per Emergency Ordinance 20-027 Approved basi	2020



Accessory Dwelling Units

Index # - File Name: 1.0022 - Single Family Dwellings Data\_Snohomish County.pdf

New	Application Expiration date extended 120 days per Emergency Ordinance 20-027 Approved Basi	2020
New	Expiration date extended 120 days per Emergency Ordinance 20-027 EPERMIT Description of W	2020
New	New 1,066 SF, 2 bedroom SFR over a 3,038 square foot garage and shop. Work includes constr	2020
New	Application Expiration date extended 120 days per Emergency Ordinance 20-027 EPERMIT Desc	2020
New	Expiration date extended 120 days per Emergency Ordinance 20-027 EPERMIT Description of W	2020
New	Expiration date extended 120 days per Emergency Ordinance 20-027 Approved Basic 19-102382	2020
New	Expiration date extended 120 days per Emergency Ordinance 20-027 EPERMIT Description of W	2020
New	Application Expiration date extended 120 days per Emergency Ordinance 20-027 EPERMIT Desc	2020
New	EPERMIT Description of Work: Build a new 2 story home on lot 4 Lake Riley Estates	2020
New	Expiration date extended 120 days per Emergency Ordinance 20-027 EPERMIT: Convert finished	2020
New	Application Expiration date extended 120 days per Emergency Ordinance 20-027 EPERMIT: New	2020
New	***Recording number-201812190322*** Application Expiration date extended 120 days per En	2020
New	Application Expiration date extended 120 days per Emergency Ordinance 20-027 Approved Basi	2020
New	Approved basic 20-105866 BP 2015 IRC Plan# 2708 Rambler style SFR w/attached ga	2020
New	Application Expiration date extended 120 days per Emergency Ordinance 20-027 Approved Basi	2020
New	Approved basic 20-105866 BP 2015 IRC Plan# 2708 Rambler style sfr w/attached gar	2020
New	Application Expiration date extended 120 days per Emergency Ordinance 20-027 Approved Basi	2020
New	Approved Basic 17-111515 BP 2015 IRC PLAN: 2972-38# 2972sf two story SFI	2020
New	Expiration date extended 120 days per Emergency Ordinance 20-027 EPERMIT Description of W	2020
New	Approved basic 19-115385 BP Plan# 2450 - 38# 2-story SFR w/attached garage	2020
New	Approved basic 17-105451 BP 2015 IRC Plan# 2477 (38#) 2 story SI	2020
New	Expiration date extended 120 days per Emergency Ordinance 20-027 Approved basic 19-114674	2020
New	Expiration date extended 120 days per Emergency Ordinance 20-027 Approved basic 16-118185	2020
New	Expiration date extended 120 days per Emergency Ordinance 20-027 Approved basic 17-105451	2020
New	Expiration date extended 120 days per Emergency Ordinance 20-027 Approved Basic 17-113335	2020
New	Application Expiration date extended 120 days per Emergency Ordinance 20-027 approved basi	2020
New	Expiration date extended 120 days per Emergency Ordinance 20-027 Approved basic 16-118176	2020
New	Application Expiration date extended 120 days per Emergency Ordinance 20-027 EPERMIT Desc	2020
New	Expiration date extended 120 days per Emergency Ordinance 20-027 EPERMIT Description of W	2020
New	Application Expiration date extended 120 days per Emergency Ordinance 20-027 EPERMIT Desc	2020
New	Application Expiration date extended 120 days per Emergency Ordinance 20-027 EPERMIT: 245!	2020
New	Application Expiration date extended 120 days per Emergency Ordinance 20-027 EPERMIT Desc	2020
New	Application Expiration date extended 120 days per Emergency Ordinance 20-027 EPERMIT Desc	2020
New	EPERMIT Description of Work: New SFR with Attached Garage	2020
New	EPERMIT Description of Work: Four Bedroom Single Family Residence	2020
New	Expiration date extended 120 days per Emergency Ordinance 20-027 EPERMIT Description of W	2020
New	EPERMIT Description of Work: install new manufactured home in existing mobile home park	2020
New	Expiration date extended 120 days per Emergency Ordinance 20-027 EPERMIT Description of W	2020
New	Expiration date extended 120 days per Emergency Ordinance 20-027 EPERMIT Description of W	2020
New	Expiration date extended 120 days per Emergency Ordinance 20-027 EPERMIT: This is a New co	2020
New	Expiration date extended 120 days per Emergency Ordinance 20-027 EPERMIT: Residential buil	2020
New	Application Expiration date extended 120 days per Emergency Ordinance 20-027 EPERMIT Desc	2020
New	Application Expiration date extended 120 days per Emergency Ordinance 20-027 EPERMIT Desc	2020
New	Application Expiration date extended 120 days per Emergency Ordinance 20-027 EPERMIT Desc	2020
New	Expiration date extended 120 days per Emergency Ordinance 20-027 EPERMIT Description of W	2020
New	Expiration date extended 120 days per Emergency Ordinance 20-027 EPERMIT Description of W	2020
New	EPERMIT Description of Work: Incomplete new construction started in 2006. We need permit tc	2020

Accessory Dwelling Units

Index # - File Name: 1.0022 - Single Family Dwellings Data\_Snohomish County.pdf

New	EPERMIT Description of Work: Bingham Residence	2020
New	Application Expiration date extended 120 days per Emergency Ordinance 20-027 Approved basi	2020
New	EPERMIT Description of Work: New SFR and Driveway	2020
New	Expiration date extended 120 days per Emergency Ordinance 20-027 EPERMIT Description of W	2020
New	Expiration date extended 120 days per Emergency Ordinance 20-027 EPERMIT Description of W	2020
New	EPERMIT Description of Work: New SFR	2020
New	Application Expiration date extended 120 days per Emergency Ordinance 20-027 EPERMIT Desc	2020
New	Expiration date extended 120 days per Emergency Ordinance 20-027 EPERMIT Description of W	2020
New	Expiration date extended 120 days per Emergency Ordinance 20-027 EPERMIT Description of W	2020
New	Expiration date extended 120 days per Emergency Ordinance 20-027 EPERMIT Description of W	2020
New	Application Expiration date extended 120 days per Emergency Ordinance 20-027 EPERMIT Desc	2020
New	Application Expiration date extended 120 days per Emergency Ordinance 20-027 EPERMIT: Sing	2020
New	Expiration date extended 120 days per Emergency Ordinance 20-027 EPERMIT: New Mobile and	2020
New	Expiration date extended 120 days per Emergency Ordinance 20-027 EPERMIT Description of W	2020
New	Application Expiration date extended 120 days per Emergency Ordinance 20-027 EPERMIT Desc	2020
New	Expiration date extended 120 days per Emergency Ordinance 20-027 EPERMIT Description of W	2020
New	Application Expiration date extended 120 days per Emergency Ordinance 20-027 EPERMIT Desc	2020
New	Expiration date extended 120 days per Emergency Ordinance 20-027 EPERMIT Description of W	2020
New	Land Use Permit Binder AFN 202007280282 Declaration of Owner Occupancy AFN 202007280282	2020
New	Application Expiration date extended 120 days per Emergency Ordinance 20-027 EPERMIT Desc	2020
New	EPERMIT Description of Work: Demolish existing 1-1/2 story residence and adjacent detached g	2020
New	Application Expiration date extended 120 days per Emergency Ordinance 20-027 EPERMIT Desc	2020
New	Application Expiration date extended 120 days per Emergency Ordinance 20-027 EPERMIT: Con:	2020
New	Expiration date extended 120 days per Emergency Ordinance 20-027 Approved basic 19-118229	2020
New	Application Expiration date extended 120 days per Emergency Ordinance 20-027 EPERMIT Desc	2020
New	Expiration date extended 120 days per Emergency Ordinance 20-027 EPERMIT: installing a new	2020
New	EPERMIT Description of Work: NEW CONSTRUCTION OF DUPLEX	2020
New	Expiration date extended 120 days per Emergency Ordinance 20-027 EPERMIT Description of W	2020
New	EPERMIT Description of Work: Build detached ADU with garage	2020
New	Application Expiration date extended 120 days per Emergency Ordinance 20-027 EPERMIT Desc	2020
New	Application Expiration date extended 120 days per Emergency Ordinance 20-027 EPERMIT Desc	2020
New	Application Expiration date extended 120 days per Emergency Ordinance 20-027 EPERMIT Desc	2020
New	Expiration date extended 120 days per Emergency Ordinance 20-027 Removing existing Mobile	2020
New	Application Expiration date extended 120 days per Emergency Ordinance 20-027 EPERMIT Desc	2020
New	Expiration date extended 120 days per Emergency Ordinance 20-027 EPERMIT Description of W	2020
New	EPERMIT Description of Work: We need to get a permit(s) for Manufactured Home that is curre	2020
New	Application Expiration date extended 120 days per Emergency Ordinance 20-027 EPERMIT Desc	2020
New	Application Expiration date extended 120 days per Emergency Ordinance 20-027 EPERMIT Desc	2020
New	Expiration date extended 120 days per Emergency Ordinance 20-027 EPERMIT Description of W	2020
New	Application Expiration date extended 120 days per Emergency Ordinance 20-027 EPERMIT Desc	2020
New	Application Expiration date extended 120 days per Emergency Ordinance 20-027 EPERMIT Desc	2020
New	Application Expiration date extended 120 days per Emergency Ordinance 20-027 EPERMIT Desc	2020
New	Construct a new duplex Follow bulletin 103	2020
New	Expiration date extended 120 days per Emergency Ordinance 20-027 EPERMIT Description of W	2020
New	Expiration date extended 120 days per Emergency Ordinance 20-027 EPERMIT Description of W	2020
New	Expiration date extended 120 days per Emergency Ordinance 20-027 EPERMIT Description of W	2020
New	Application Expiration date extended 120 days per Emergency Ordinance 20-027 EPERMIT Desc	2020

Accessory Dwelling Units

Index # - File Name: 1.0022 - Single Family Dwellings Data\_Snohomish County.pdf

New	Expiration date extended 120 days per Emergency Ordinance 20-027 EPERMIT: 2 story SFR w/at	2020
New	Application Expiration date extended 120 days per Emergency Ordinance 20-027 EPERMIT Desc	2020
New	Application Expiration date extended 120 days per Emergency Ordinance 20-027 EPERMIT Desc	2020
New	Application Expiration date extended 120 days per Emergency Ordinance 20-027 EPERMIT: Resi	2020
New	New 6,496 SF SFR on 2 parcels. Existing SFR and sport court to be removed.	2020
New	Expiration date extended 120 days per Emergency Ordinance 20-027 EPERMIT Description of W	2020
New	permit for mobile home placed on site in 1979	2020
New	Application Expiration date extended 120 days per Emergency Ordinance 20-027 EPERMIT Desc	2020
New	Application Expiration date extended 120 days per Emergency Ordinance 20-027 Approved Basi	2020
New	Application Expiration date extended 120 days per Emergency Ordinance 20-027 Approved basi	2020
New	Expiration date extended 120 days per Emergency Ordinance 20-027 EPERMIT Description of W	2020
New	Application Expiration date extended 120 days per Emergency Ordinance 20-027 EPERMIT Desc	2020
New	Expiration date extended 120 days per Emergency Ordinance 20-027 EPERMIT Description of W	2020
New	EPERMIT Description of Work: Construction of new SFR & driveway	2020
New	Application Expiration date extended 120 days per Emergency Ordinance 20-027 EPERMIT Desc	2020
New	EPERMIT Description of Work: Build an 848sqft detached accessory dewing unit.	2020
New	EPERMIT Description of Work: New single family dwelling	2020
New	EPERMIT Description of Work: Existing mobile home was constructed in 1980 without a permit.	2020
New	Application Expiration date extended 120 days per Emergency Ordinance 20-027 EPERMIT Desc	2020
New	Application Expiration date extended 120 days per Emergency Ordinance 20-027 New 2578 SQ	2020
New	Application Expiration date extended 120 days per Emergency Ordinance 20-027 EPERMIT Desc	2020
New	Application Expiration date extended 120 days per Emergency Ordinance 20-027 EPERMIT Desc	2020
New	Application Expiration date extended 120 days per Emergency Ordinance 20-027 EPERMIT Desc	2020
New	Expiration date extended 120 days per Emergency Ordinance 20-027 EPERMIT Description of W	2020
New	Expiration date extended 120 days per Emergency Ordinance 20-027 EPERMIT: NEW MANUFAC	2020
New	EPERMIT Description of Work: Install new Double wide MFH RELATED 20-107619 LDA; 20-1085	2020
New	Expiration date extended 120 days per Emergency Ordinance 20-027 EPERMIT Description of W	2020
New	Expiration date extended 120 days per Emergency Ordinance 20-027 EPERMIT Description of W	2020
New	Application Expiration date extended 120 days per Emergency Ordinance 20-027 EPERMIT Desc	2020
New	EPERMIT Description of Work: New Construction of a single family residence.	2020
New	Expiration date extended 120 days per Emergency Ordinance 20-027 EPERMIT: 3 bedroom SFR w	2020
New	Expiration date extended 120 days per Emergency Ordinance 20-027 Clearing and grading for a	2020
New	Expiration date extended 120 days per Emergency Ordinance 20-027 Single family residence, 2 s	2020
New	Expiration date extended 120 days per Emergency Ordinance 20-027 EPERMIT: CONSTRUCTION	2020
New	Expiration date extended 120 days per Emergency Ordinance 20-027 EPERMIT Description of W	2020
New	Expiration date extended 120 days per Emergency Ordinance 20-027 EPERMIT Description of W	2020
New	Application Expiration date extended 120 days per Emergency Ordinance 20-027 EPERMIT: Buil	2020
New	Application Expiration date extended 120 days per Emergency Ordinance 20-027 EPERMIT Desc	2020
New	EPERMIT Description of Work: Building a new, single family residence.	2020
New	Expiration date extended 120 days per Emergency Ordinance 20-027 EPERMIT: 1643 sf SFR w/ 5	2020

Accessory Dwelling Units

Index # - File Name: 1.0022 - Single Family Dwellings Data\_Snohomish County.pdf

Folder status	Parcel #
Closed	27052500401000
Closed	00413400000200
Closed	00460100003100
Closed	00491400100309
Closed	00512200004600
Closed	00802400007300
Closed	00570400300404
Closed	29061400301100
Closed	29062400401500
Closed	29062400401700
Closed	00776900004500
Closed	30062800302900
Closed	31060400402100
Closed	00445100001401
Closed	00480700001201
Closed	00480700003100
Closed	00481900001200
Closed	00489700200701
Closed	29061100400600
Closed	00814500000900
Closed	30072100300300
Closed	32063600202300
Closed	27073000401300
Closed	00830500007800
Closed	00831600002100
Closed	00831600002200
Closed	00831600002300
Closed	00831600002400
Closed	27063400100300
Closed	29063500304500
Closed	00414400201800
Closed	00803600000200
Closed	00833100000700
Closed	00833100001200
Closed	00833100002500
Closed	00833100002700
Closed	29061400302700
Closed	30071900400600
Closed	00834600000200
Closed	00834600000500
Closed	00834600001300
Closed	00834600001400
Closed	00834600001500
Closed	00834600002500
Closed	00485300001900
Closed	00611300000700

Accessory Dwelling Units

Index # - File Name: 1.0022 - Single Family Dwellings Data\_Snohomish County.pdf

Closed	00960013305100
Closed	00590700007500
Closed	00491400300105
Closed	32042500401400
Closed	00374100600103
Closed	00637600000100
Closed	28050100105900
Closed	28050100106300
Closed	28050100106800
Closed	00960003902300
Closed	00394406400300
Closed	32063300301600
Closed	27050300303400
Closed	00848900000700
Closed	00848900000900
Closed	31053300401200
Closed	00849600000400
Closed	00577700606300
Closed	00849500002900
Closed	00460000004500
Closed	30051000204900
Closed	31053300401200
Closed	28063100200900
Closed	27070400401300
Closed	30071900400700
Closed	00500100004400
Closed	29061000102200
Closed	00836000000100
Closed	00836000000400
Closed	28060300400700
Closed	32080200100500
Closed	30041300300100
Closed	29061900100400
Closed	27052100300100
Closed	00385300002900
Closed	00834600002600
Closed	00834600002700
Closed	00834600003300
Closed	29062400401600
Closed	27062600300700
Closed	29063400101800
Closed	27052700205700
Closed	00372901000911
Closed	00403800007501
Closed	00835200000400
Closed	00835300000700
Closed	00835300001400

Accessory Dwelling Units

Index # - File Name: 1.0022 - Single Family Dwellings Data\_Snohomish County.pdf

Closed	00835300001500
Closed	00835300001900
Closed	27073200200100
Closed	00834600002200
Closed	00834600000400
Closed	00493900010403
Closed	30061200401000
Closed	28063100201300
Closed	31061700301100
Closed	00625300000301
Closed	00588100200403
Closed	00833100000200
Closed	32053200200200
Closed	00833700000400
Closed	00833700000700
Closed	00833700000800
Closed	00427100000100
Closed	00577600300300
Closed	00833100003100
Closed	00833100003400
Closed	00833100003600
Closed	00833300000100
Closed	00833300000200
Closed	00833300000300
Closed	00833300000400
Closed	00833300000500
Closed	00833300000600
Closed	00833300000700
Closed	00833300000900
Closed	00833300001000
Closed	00833300001100
Closed	00833300001300
Closed	00577600300100
Closed	00803600000300
Closed	27062700202300
Closed	32040400201100
Closed	30073100400100
Closed	31063100200800
Closed	30070800200400
Closed	00837300001200
Closed	00837300001600
Closed	00837300000100
Closed	00837300001700
Closed	00837300002000
Closed	00837300002200
Closed	00837300002300
Closed	00837300002500

Accessory Dwelling Units

Index # - File Name: 1.0022 - Single Family Dwellings Data\_Snohomish County.pdf

Closed	00837300002700
Closed	00837300002800
Closed	00837300002900
Closed	00837300003000
Closed	00837300003500
Closed	00837300004500
Closed	00837300005100
Closed	00837300005400
Closed	00837300005900
Closed	00837300006000
Closed	00837300006100
Closed	00837300006200
Closed	00837300006300
Closed	00837300006500
Closed	00837300007400
Closed	00499100200400
Closed	00837100005500
Closed	00837100005600
Closed	00837100005800
Closed	00837100005900
Closed	00837100006000
Closed	32081000106800
Closed	31041800301700
Closed	00577600300700
Closed	00837700000800
Closed	00837700000900
Closed	00837600000400
Closed	30073000401100
Closed	32053300400900
Closed	00831700001500
Closed	00831700001600
Closed	00831700001700
Closed	00577600300400
Closed	31050100102300
Closed	00831200008100
Closed	00831200008800
Closed	00537800001804
Closed	00516700000700
Closed	28060500400200
Closed	29063300100600
Closed	30052000302200
Closed	00466100005500
Closed	00537800001703
Closed	00537800001704
Closed	00543200000900
Closed	30061900402900
Closed	00831600002000

Accessory Dwelling Units

Index # - File Name: 1.0022 - Single Family Dwellings Data\_Snohomish County.pdf

Closed	00830500002900
Closed	00830500003000
Closed	00830500003300
Closed	00830500003400
Closed	31052600300400
Closed	00557000000600
Closed	27062200401200
Closed	00498800100100
Closed	00830500000300
Closed	00830500000500
Closed	00830500001800
Closed	00830500002000
Closed	00830500002200
Closed	00830500002700
Closed	00830500008400
Closed	00830600000600
Closed	00828500001500
Closed	32090800302900
Closed	00827400000300
Closed	00827400001100
Closed	00827600000100
Closed	00827600001500
Closed	00827700004200
Closed	30063200302700
Closed	00828800005500
Closed	00828800005600
Closed	00828800005700
Closed	31060400400600
Closed	00373101100805
Closed	00375000002902
Closed	00830000001700
Closed	00830000001800
Closed	00830000002300
Closed	00830000002500
Closed	00830000002700
Closed	00830000003000
Closed	00830000003400
Closed	00830000003700
Closed	00830000004100
Closed	00830000004400
Closed	00830000005400
Closed	00830000006500
Closed	00830000006600
Closed	00830100001700
Closed	00830100001800
Closed	00830100001900
Closed	00830100002000



Accessory Dwelling Units

Index # - File Name: 1.0022 - Single Family Dwellings Data\_Snohomish County.pdf

Closed	27071800102600
Closed	00830500000100
Closed	29063300301700
Closed	29063300302000
Closed	00826000000100
Closed	32063000300400
Closed	32053300303400
Closed	00827100000100
Closed	00827100000800
Closed	00827100000900
Closed	00827100001000
Closed	00827100001400
Closed	00827100003900
Closed	00827100004400
Closed	00827100004500
Closed	00827100004600
Closed	00827100004700
Closed	00827100004800
Closed	00827100005400
Closed	29060500203600
Closed	00823400010300
Closed	00823400011700
Closed	00824000003200
Closed	00824000006600
Closed	00824400000900
Closed	00511900200902
Closed	00394510601600
Closed	00824800000800
Closed	00589100001701
Closed	32053600302300
Closed	30042300302200
Closed	30042300302300
Closed	30042300302600
Closed	32090900301400
Closed	00814900004600
Closed	31062000402200
Closed	27060800300300
Closed	00422500005900
Closed	27070800301000
Closed	00817800000600
Closed	00817800000800
Closed	00817800001300
Closed	00820700001000
Closed	00823300010700
Closed	00823700001200
Closed	30041400400800
Closed	00823900000200

Accessory Dwelling Units

Index # - File Name: 1.0022 - Single Family Dwellings Data\_Snohomish County.pdf

Closed	30042300303100
Closed	30042300303300
Closed	00823400002600
Closed	00812600001100
Closed	31060400301500
Closed	29061700306300
Closed	00805800001400
Closed	00480401602304
Closed	31062900403600
Closed	00589600011800
Closed	28073000302900
Closed	32053300101700
Closed	32063300303200
Closed	00589600007200
Closed	00837600006700
Closed	00837600006800
Closed	00837600007000
Closed	00837600007200
Closed	00837600006100
Closed	00837600008600
Closed	00837600008700
Closed	00837600009500
Closed	00837600009700
Closed	00837600008200
Closed	00837600010400
Closed	00837600010600
Closed	30070600301600
Closed	30070600302300
Closed	00838000000700
Closed	29051200400900
Closed	00836500000700
Closed	00836500004200
Closed	32071900100400
Closed	32071900100400
Closed	00796600012200
Closed	00838800000600
Closed	00838800002500
Closed	00838800002700
Closed	00838800002800
Closed	00838800002900
Closed	00838800004400
Closed	00838800005100
Closed	00838800008700
Closed	00838800004900
Closed	28051200101500
Closed	31063000402000
Closed	30063200401300

Accessory Dwelling Units

Index # - File Name: 1.0022 - Single Family Dwellings Data\_Snohomish County.pdf

Closed	29062300302300
Closed	00839000000200
Closed	00839000000900
Closed	00839000001000
Closed	28052900403500
Closed	30040200400500
Closed	00839200000500
Closed	00839200004400
Closed	00464200001800
Closed	00463302600101
Closed	00463302600102
Closed	00463302600103
Closed	00463302600104
Closed	30042300201900
Closed	00796600019600
Closed	00839500000300
Closed	00839500000500
Closed	00839500000900
Closed	00840500000400
Closed	00840500000200
Closed	00840500001500
Closed	31042700202700
Closed	31041300201300
Closed	00841400000200
Closed	00841400000100
Closed	00841400000500
Closed	00841400000600
Closed	00841400000700
Closed	00841400001000
Closed	00841400001900
Closed	00841400002100
Closed	00841400002200
Closed	00617000001900
Closed	00841500002000
Closed	00841500000900
Closed	00841500001000
Closed	00841500001200
Closed	00841500001500
Closed	00841500001600
Closed	32042700202400
Closed	28070800201600
Closed	30061700101000
Closed	31043000200800
Closed	00841800000200
Closed	00841800001900
Closed	00841800002000
Closed	31063000402100

Accessory Dwelling Units

Index # - File Name: 1.0022 - Single Family Dwellings Data\_Snohomish County.pdf

Closed	00841900000200
Closed	00841900000500
Closed	00841900000800
Closed	00841900002000
Closed	00842000001600
Closed	00842000001800
Closed	00842000002300
Closed	00842000002500
Closed	00842000002600
Closed	00842000003900
Closed	00842000004700
Closed	00842000004800
Closed	00842000004900
Closed	00842000000700
Closed	00842000000900
Closed	00842000001300
Closed	28060900101100
Closed	00842500000600
Closed	00842500000700
Closed	00842500001500
Closed	00842500001900
Closed	00842300000600
Closed	00842300003500
Closed	00543600003500
Closed	27063200400400
Closed	28071600104000
Closed	00554800100413
Closed	00577700602100
Closed	00577700603000
Closed	00577700603100
Closed	29060200200800
Closed	00842600000400
Closed	00842800004900
Closed	00842800005000
Closed	00842800005200
Closed	32053300202500
Closed	00831600005100
Closed	00831600005200
Closed	00831600005300
Closed	31053300401200
Closed	00843800000200
Closed	00843800000400
Closed	00843800000500
Closed	00843700000500
Closed	00843700000600
Closed	00843700001200
Closed	00467100005400

Accessory Dwelling Units

Index # - File Name: 1.0022 - Single Family Dwellings Data\_Snohomish County.pdf

Closed	0084400000600
Closed	0084400000700
Closed	0084400001000
Closed	0084400001100
Closed	0084400002000
Closed	0084400002300
Closed	0084410000200
Closed	0084410000300
Closed	0084410000400
Closed	0057910000100
Closed	29061200301300
Closed	27052500302900
Closed	29073200200200
Closed	0084450000200
Closed	0084450000400
Closed	0084450000600
Closed	0084450000700
Closed	0084450000800
Closed	30061100401300
Closed	00467100010100
Closed	27052500303100
Closed	00373002600309
Closed	0084510000400
Closed	0084510000500
Closed	0084510000600
Closed	0084490000100
Closed	0084490000200
Closed	0084490000400
Closed	0084490000500
Closed	0084500000300
Closed	00579100001100
Closed	31053300401200
Closed	00630600001700
Closed	31053300401200
Closed	30062300401100
Closed	28062300100800
Closed	00427100007700
Closed	0084620000200
Closed	0084620000400
Closed	0084620000500
Closed	00846200002100
Closed	00846200002500
Closed	00846200003800
Closed	00846200003900
Closed	00846200003100
Closed	00846200003200
Closed	31043000301300

Accessory Dwelling Units

Index # - File Name: 1.0022 - Single Family Dwellings Data\_Snohomish County.pdf

Closed	28073500202800
Closed	00846700000600
Closed	00846700000900
Closed	00846700001200
Closed	00846700001400
Closed	00960013302100
Closed	00392400000101
Closed	32052900403800
Closed	00960005304700
Closed	00577900000300
Closed	27051400203000
Closed	00403900023703
Closed	32071600100800
Closed	32053000200300
Closed	30050900409300
Closed	30052200210700
Closed	30052200210800
Closed	30070800200700
Closed	00847800001200
Closed	00847800001300
Closed	00621500004100
Closed	00409500003800
Closed	00394406300102
Closed	00394400602800
Closed	00394400504700
Closed	00394400505100
Closed	00848400000200
Closed	00848400000300
Closed	00394400602300
Closed	00494600200406
Closed	00494600201301
Closed	00494600300507
Closed	00494600301107
Closed	00499100101500
Closed	00579100004500
Closed	00579100004500
Closed	32040500401500
Closed	32040800402300
Closed	32040900200200
Closed	32040900301100
Closed	32071100100500
Closed	32071900100500
Closed	32062000201200
Closed	32042200101400
Closed	32042200102500
Closed	32042400102200
Closed	32042800200100

Accessory Dwelling Units

Index # - File Name: 1.0022 - Single Family Dwellings Data\_Snohomish County.pdf

Closed	32063100201100
Closed	32063100302400
Closed	00483000001300
Closed	00394509901200
Closed	00394511000602
Closed	00409000000100
Closed	31042700103100
Closed	31043100100600
Closed	31063400100500
Closed	31063400400700
Closed	31043500200900
Closed	00801800001300
Closed	31050100102100
Closed	31040400100800
Closed	31040400301400
Closed	31051300201300
Closed	31051800203000
Closed	31051800300800
Closed	31042200201600
Closed	31042200307100
Closed	31052500402100
Closed	30063200200400
Closed	30043500100900
Closed	00828500003700
Closed	00384500009500
Closed	00385300009800
Closed	00462000001300
Closed	00470600006000
Closed	00511000000300
Closed	00516100001400
Closed	00520200004100
Closed	28072100101900
Closed	00543400005100
Closed	00828800000800
Closed	00828800001400
Closed	00551500012600
Closed	00554300000100
Closed	00557300204200
Closed	00625200001200
Closed	00631600005400
Closed	00828800001700
Closed	00828800002100
Closed	00736500001500
Closed	30050100102400
Closed	30040200400400
Closed	30040200401800
Closed	00611300016500

Accessory Dwelling Units

Index # - File Name: 1.0022 - Single Family Dwellings Data\_Snohomish County.pdf

Closed	00516700009400
Closed	00516700009700
Closed	00604900000602
Closed	00431400100202
Closed	00442100001500
Closed	00491900500401
Closed	00492000303800
Closed	00493301400206
Closed	00516700003300
Closed	00516700006600
Closed	30060200204400
Closed	30060300201400
Closed	30050900103600
Closed	00828500000600
Closed	00828500001000
Closed	00828500000300
Closed	30071900301700
Closed	30062000301500
Closed	30042300301200
Closed	30042300301400
Closed	30062300200400
Closed	30052400400100
Closed	29062100200800
Closed	29062700201000
Closed	29063300101800
Closed	29061000200300
Closed	29060300200400
Closed	00625800002800
Closed	00625800002900
Closed	00625800004000
Closed	00780200001400
Closed	00780200001500
Closed	00792100000400
Closed	00796700000900
Closed	00552300300702
Closed	00552300400901
Closed	00542900006900
Closed	00552300300102
Closed	00396500005700
Closed	00420500000900
Closed	00802400005300
Closed	00802400002400
Closed	00711600000500
Closed	00711600001200
Closed	28060300401600
Closed	28060400304700
Closed	28061100301500



Accessory Dwelling Units

Index # - File Name: 1.0022 - Single Family Dwellings Data\_Snohomish County.pdf

Closed	28071200301100
Closed	28041300303200
Closed	28071600100600
Closed	28071600300300
Closed	28051700408500
Closed	28062500302300
Closed	28082500300600
Closed	28082800301500
Closed	28053100202700
Closed	28053100202800
Closed	28073300303200
Closed	28073500102000
Closed	28083500100100
Closed	28083500101200
Closed	28053600104900
Closed	00511900300100
Closed	27051000407400
Closed	00555300300501
Closed	00511900100100
Closed	00576800400500
Closed	00577700605900
Closed	00617300100400
Closed	00623700002900
Closed	00623700004400
Closed	00634100000500
Closed	00637600000900
Closed	00460100002600
Closed	00460000004600
Closed	00460000005900
Closed	00460200014900
Closed	00460200017800
Closed	00460200021100
Closed	00419500001504
Closed	00427100006400
Closed	00427100006700
Closed	00427100008000
Closed	00403800001005
Closed	27052500403400
Closed	27062100402800
Closed	27062100403300
Closed	27052800103500
Closed	27062800305600
Closed	27072800300100
Closed	27062800402200
Closed	27073000401700
Closed	27073100202000
Closed	27053500101200

Accessory Dwelling Units

Index # - File Name: 1.0022 - Single Family Dwellings Data\_Snohomish County.pdf

Closed	27063500301500
Closed	00372801401604
Closed	00373000100403
Closed	00373002200601
Closed	27080500300900
Closed	00562800001200
Closed	27071000402900
Closed	27071000403200
Closed	27061800103300
Closed	27081800400100
Closed	28061100200500
Closed	00960002500501
Closed	27051400107400
Closed	00960012900200
Closed	32072900300400
Closed	31053300401200
Closed	31040100100700
Closed	28073000203200
Closed	27071900401400
Closed	27061800401200
Closed	27052100207900
Closed	27062100202200
Closed	27051600403800
Closed	27061600202300
Closed	27081100200500
Closed	27051400105300
Closed	27071400101000
Closed	27051100103100
Closed	27051100203100
Closed	27071100100800
Closed	27071100201000
Closed	27051100408300
Closed	27051000300900
Closed	00471400001200
Closed	27080300402100
Closed	27050300302600
Closed	28073400305700
Closed	27060300201300
Closed	00373002203200
Closed	00373002200105
Closed	00373002200106
Closed	00373002801204
Closed	00373002801205
Closed	00372900701203
Closed	27063400401500
Closed	27053500200200
Closed	27063500205400

Accessory Dwelling Units

Index # - File Name: 1.0022 - Single Family Dwellings Data\_Snohomish County.pdf

Closed	27062800402400
Closed	27063000204500
Closed	27062800102600
Closed	27062800201600
Closed	27052600402100
Closed	27062600201800
Closed	27062600202300
Closed	27052700206800
Closed	00403800000402
Closed	00403800001702
Closed	00373003001203
Closed	00373700301105
Closed	00414400105100
Closed	00403900019308
Closed	00403900023903
Closed	00403900023905
Closed	00403800015303
Closed	00403800803100
Closed	00427100008200
Closed	00427100008400
Closed	00427100006800
Closed	00419500000500
Closed	00425800000600
Closed	00428200001700
Closed	00427100007900
Closed	00433200001900
Closed	00460200014900
Closed	00460100009900
Closed	00460100010200
Closed	00623700006200
Closed	00578100001800
Closed	00589500001100
Closed	00577700502900
Closed	00556700001400
Closed	00509900000900
Closed	00500900001902
Closed	00554800100414
Closed	00516500000400
Closed	00526100501200
Closed	00512000200100
Closed	00512000210700
Closed	00384200000300
Closed	28073100302300
Closed	28063300302700
Closed	28072700200600
Closed	28072700202300
Closed	28062500102300

Accessory Dwelling Units

Index # - File Name: 1.0022 - Single Family Dwellings Data\_Snohomish County.pdf

Closed	28042400406200
Closed	28062400402000
Closed	28042500100300
Closed	28062200201300
Closed	28062200403900
Closed	28081800300200
Closed	28061500400400
Closed	28061500400500
Closed	28071500400600
Closed	28061500301700
Closed	28061100102800
Closed	28071000401000
Closed	28060400401900
Closed	28060400303700
Closed	00668900000500
Closed	00668900000700
Closed	00802400002600
Closed	00782200000400
Closed	00784500000900
Closed	00792200001100
Closed	00802400006600
Closed	00871600004600
Closed	00802400004700
Closed	00420500001700
Closed	00399200002200
Closed	00396500000900
Closed	00420600000202
Closed	00538000005801
Closed	00552400701802
Closed	00574100000800
Closed	00582500400700
Closed	00592100000600
Closed	00592100000700
Closed	00592100000800
Closed	00588100200404
Closed	00608100700201
Closed	00796700001100
Closed	00795800000700
Closed	00795800002400
Closed	00796700000600
Closed	29060100201000
Closed	00789500001600
Closed	00789500001700
Closed	29060300400800
Closed	29060400302400
Closed	29060400403100
Closed	29060900401200

Accessory Dwelling Units

Index # - File Name: 1.0022 - Single Family Dwellings Data\_Snohomish County.pdf

Closed	29061100301900
Closed	29061200302700
Closed	29061400202700
Closed	29061500102100
Closed	29063400300600
Closed	29062400400300
Closed	29062600101100
Closed	29061500201200
Closed	29061600401500
Closed	29061900401800
Closed	29062000201100
Closed	29062000300300
Closed	29062000302500
Closed	29062100103200
Closed	30052300200300
Closed	30062000303100
Closed	30062000303900
Closed	30062100103500
Closed	30062000201100
Closed	30071900103100
Closed	00828500003100
Closed	00828500003400
Closed	00828500002200
Closed	00828500002400
Closed	00828500001800
Closed	00828500001900
Closed	00422500005800
Closed	00828500000100
Closed	30080700202700
Closed	30051300100400
Closed	30041400402400
Closed	30040200402100
Closed	30050200100400
Closed	30060200200100
Closed	30060300200700
Closed	30040600102000
Closed	00492000105400
Closed	00442100001700
Closed	00441900001700
Closed	00442100000900
Closed	00466200002600
Closed	00385500100201
Closed	00385900300601
Closed	00604900100003
Closed	00590700025503
Closed	00591200100403
Closed	00590700021902

Accessory Dwelling Units

Index # - File Name: 1.0022 - Single Family Dwellings Data\_Snohomish County.pdf

Closed	00611300009500
Closed	00731600000300
Closed	00828800002600
Closed	00828800002700
Closed	00627300011300
Closed	00627300011400
Closed	00627300010100
Closed	00625200008900
Closed	00625200012700
Closed	00604500001400
Closed	00604500002300
Closed	00828800001500
Closed	00828800001600
Closed	00590600000500
Closed	00590700006500
Closed	00590700011501
Closed	00600200001702
Closed	00600300100500
Closed	00600600001100
Closed	00557100403700
Closed	00551500008700
Closed	00551500009600
Closed	00551500009700
Closed	00551500008000
Closed	00551500008100
Closed	00828700000200
Closed	00543800002200
Closed	00543300005600
Closed	00543300005800
Closed	00520200008100
Closed	00532000002700
Closed	00543300000400
Closed	00511000003000
Closed	00480000012400
Closed	00480000012900
Closed	00487100000801
Closed	00480000007200
Closed	00444800000900
Closed	00385300009700
Closed	30063600202200
Closed	00406400001100
Closed	00422500007900
Closed	00422500008000
Closed	00422500008100
Closed	00423700000400
Closed	30073300200400
Closed	30062900302600

Accessory Dwelling Units

Index # - File Name: 1.0022 - Single Family Dwellings Data\_Snohomish County.pdf

Closed	30063000302000
Closed	30073000203100
Closed	30052400402100
Closed	30042600401400
Closed	30042600401500
Closed	31052500400200
Closed	31052500401100
Closed	31052500401700
Closed	31042300101100
Closed	31042400300400
Closed	31042000101600
Closed	31052000100300
Closed	31042100102100
Closed	31041800403500
Closed	31051900303200
Closed	31061700201900
Closed	31061700303200
Closed	31041200302400
Closed	31041300102600
Closed	31060700200300
Closed	31050400300900
Closed	31040400200600
Closed	31040500301000
Closed	31040500301000
Closed	31050500202000
Closed	31060500202300
Closed	31060600101500
Closed	31060600103000
Closed	31043500202500
Closed	31053500402100
Closed	31063300400800
Closed	00379500001601
Closed	00384300000100
Closed	00384600000901
Closed	00394400504300
Closed	31053200300800
Closed	31052600100200
Closed	31042700102300
Closed	31042700201100
Closed	00409000000700
Closed	00429800000600
Closed	00394510200500
Closed	00483000001100
Closed	00480700000403
Closed	00482900002300
Closed	00482900002800
Closed	00480700001600

Accessory Dwelling Units

Index # - File Name: 1.0022 - Single Family Dwellings Data\_Snohomish County.pdf

Closed	00394405000701
Closed	00394406000200
Closed	00394406000700
Closed	00394406501000
Closed	00394406400101
Closed	00394406600705
Closed	00394406601200
Closed	00394507000903
Closed	32043200202600
Closed	32053200303100
Closed	32063200102300
Closed	32053000201700
Closed	32052400100900
Closed	32042700400700
Closed	32062000201800
Closed	32051900300700
Closed	32041700404000
Closed	32051800101100
Closed	32051800201600
Closed	32061000202100
Closed	32041300201200
Closed	32040900200400
Closed	32080800200900
Closed	32040900302000
Closed	32050900200900
Closed	32090700401800
Closed	32100400201400
Closed	32040500201500
Closed	00630700003000
Closed	00778800000600
Closed	32040400102700
Closed	32050400201400
Closed	00585200005100
Closed	00537400002000
Closed	00537400002100
Closed	00579100001503
Closed	00494600100403
Closed	00483000002100
Closed	00483000002400
Closed	00489700305100
Closed	30061300200500
Closed	00848400001900
Closed	00848500000400
Closed	00848500000600
Closed	00848500000700
Closed	00848500000800
Closed	00848500000900



Accessory Dwelling Units

Index # - File Name: 1.0022 - Single Family Dwellings Data\_Snohomish County.pdf

Closed	00394400505900
Closed	00848200004600
Closed	00848200004700
Closed	00848200004800
Closed	00394400405700
Closed	00394400502800
Closed	00394400503200
Closed	00394400503600
Closed	00847800001100
Closed	00394400403400
Closed	00394400404000
Closed	00394400404300
Closed	00394400404600
Closed	00394400405000
Closed	00848200000200
Closed	00848200000500
Closed	00848200000600
Closed	00848200000700
Closed	00848200001100
Closed	00848200001300
Closed	00848200001500
Closed	00848200001600
Closed	00848200001700
Closed	00848200001800
Closed	00848200001900
Closed	00848200002000
Closed	00848200002100
Closed	00848200002200
Closed	00848200002400
Closed	00848200002500
Closed	00848200002700
Closed	00848200002800
Closed	00848200002900
Closed	00848200003000
Closed	00848200003200
Closed	00848200003300
Closed	00848200003400
Closed	00848200003600
Closed	00848200003700
Closed	00848200003800
Closed	00848200003900
Closed	00848200004000
Closed	00848200004100
Closed	00848200004200
Closed	00848200004300
Closed	30041400400500
Closed	00394400304300

Accessory Dwelling Units

Index # - File Name: 1.0022 - Single Family Dwellings Data\_Snohomish County.pdf

Closed	00512000200200
Closed	00847800000100
Closed	30052200210900
Closed	00394403804700
Closed	00847800000400
Closed	00847800000500
Closed	00847800000600
Closed	00847800000700
Closed	00847800000800
Closed	00847800000900
Closed	00847800001000
Closed	30050900408900
Closed	00467100005000
Closed	30071100101100
Closed	00440100000103
Closed	30061100101100
Closed	31043000301100
Closed	27050300401500
Closed	29062800402500
Closed	31062900301200
Closed	32041100200800
Closed	27070200203900
Closed	00846200003700
Closed	28071200400500
Closed	29051100105200
Closed	00394402000100
Closed	00400800002100
Closed	00846200003400
Closed	00846100000100
Closed	00846100000200
Closed	00846100000300
Closed	00846100000400
Closed	00846100000500
Closed	00846100000600
Closed	00846100000700
Closed	00846100000800
Closed	00846100001300
Closed	00846100001400
Closed	00846100001500
Closed	00846100001600
Closed	00846100001900
Closed	00846100002200
Closed	00846100002500
Closed	00846100002600
Closed	00846100002700
Closed	00846100002800
Closed	00846100002900

Accessory Dwelling Units

Index # - File Name: 1.0022 - Single Family Dwellings Data\_Snohomish County.pdf

Closed	00846100003200
Closed	00846100003600
Closed	00846100003900
Closed	00846100004000
Closed	00846100004100
Closed	00846200002600
Closed	32060900101300
Closed	00846200000100
Closed	00846200002200
Closed	00846200002300
Closed	00846200002400
Closed	00846200001100
Closed	00846200001200
Closed	00846200001300
Closed	00846200001400
Closed	00846200001700
Closed	00846200001800
Closed	00585200005604
Closed	30062500202000
Closed	31062800201500
Closed	31062800201600
Closed	31040900202300
Closed	31040900202200
Closed	00518700000300
Closed	00845800000100
Closed	00845800000200
Closed	00845800000300
Closed	00845800000400
Closed	00845800000600
Closed	00845800000800
Closed	00845800000900
Closed	00845800001100
Closed	00845800001400
Closed	00845800001500
Closed	30062500201200
Closed	30062500201300
Closed	30062500201400
Closed	30051200103200
Closed	00409800000802
Closed	00518700000400
Closed	00518700000600
Closed	00518700000500
Closed	00845100000100
Closed	27073100100700
Closed	00960003901000
Closed	32053400202700
Closed	31043500400600

Accessory Dwelling Units

Index # - File Name: 1.0022 - Single Family Dwellings Data\_Snohomish County.pdf

Closed	32040900201700
Closed	31050600101600
Closed	27052500303000
Closed	00480401600700
Closed	29061700301900
Closed	00844100002700
Closed	00844100000700
Closed	00844100000500
Closed	00844100000100
Closed	00844100001000
Closed	00844100001100
Closed	00844100001300
Closed	00844100001500
Closed	00844100001600
Closed	00844100001700
Closed	00844100001800
Closed	00844100001900
Closed	00844100002300
Closed	00844000000900
Closed	28070700100900
Closed	00492000301902
Closed	00385700100401
Closed	31053300401200
Closed	00842800006700
Closed	31043000200400
Closed	30062400400100
Closed	00842800006800
Closed	00842800006900
Closed	00842800007000
Closed	00842800007100
Closed	00842800007200
Closed	00842800007300
Closed	00842800007400
Closed	00842800007500
Closed	00842800007600
Closed	00842800007700
Closed	00842800007800
Closed	00842800015100
Closed	00842800015600
Closed	00842800015800
Closed	00842800002900
Closed	00842800003000
Closed	00842800003100
Closed	00842800003200
Closed	00842800003300
Closed	00842800003400
Closed	00842800003500

Accessory Dwelling Units

Index # - File Name: 1.0022 - Single Family Dwellings Data\_Snohomish County.pdf

Closed	00842800003600
Closed	00842800003700
Closed	00842800003800
Closed	00842800003900
Closed	00842800004000
Closed	00842800004100
Closed	00842800004200
Closed	00842800004300
Closed	00842800004400
Closed	00842800004500
Closed	00842800004600
Closed	00842800004700
Closed	00842600000600
Closed	00842600000700
Closed	00842600000200
Closed	00842600000300
Closed	00394405100801
Closed	00538000009601
Closed	00538000009604
Closed	29062600201400
Closed	27090500201300
Closed	00403800010602
Closed	00422500007200
Closed	00480000009300
Closed	00480000009500
Closed	29062000205100
Closed	31051800201700
Closed	29061400102300
Closed	00842000001400
Closed	00841700004200
Closed	00394406201100
Closed	00841900001200
Closed	00841900001600
Closed	00841900001700
Closed	00841900001800
Closed	00841900000600
Closed	00841900000400
Closed	00841800002100
Closed	00841800002600
Closed	00841800002800
Closed	00841800000400
Closed	00841800000600
Closed	00841800000700
Closed	00841800001300
Closed	00841700001600
Closed	00841700000700
Closed	00841700003900

Accessory Dwelling Units

Index # - File Name: 1.0022 - Single Family Dwellings Data\_Snohomish County.pdf

Closed	00841700001400
Closed	00625200005200
Closed	00841700001800
Closed	00841700002000
Closed	00841700002200
Closed	00841700002300
Closed	00841700002400
Closed	00841700002500
Closed	00841700002600
Closed	00841700002700
Closed	00841700002900
Closed	00841500001900
Closed	00796600023500
Closed	00796600023600
Closed	00841700000200
Closed	00841700000300
Closed	00841700000400
Closed	00841700000500
Closed	00841700000600
Closed	00841700000800
Closed	00841700000900
Closed	00841700001000
Closed	00841500002400
Closed	00841500002600
Closed	00841500002700
Closed	00841500002800
Closed	00841500003100
Closed	00841500003200
Closed	00841500003300
Closed	00841500003500
Closed	00841500003700
Closed	00841500003800
Closed	00841500003900
Closed	00841500004000
Closed	00841500004100
Closed	00841500004300
Closed	00841500000100
Closed	00841500000200
Closed	00841500000400
Closed	00841500000500
Closed	00841500000700
Closed	32080900202700
Closed	31043200200700
Closed	00796600021100
Closed	00796600021200
Closed	00796600021300
Closed	00796600021500

Accessory Dwelling Units

Index # - File Name: 1.0022 - Single Family Dwellings Data\_Snohomish County.pdf

Closed	00796600021600
Closed	00796600021700
Closed	00796600021800
Closed	00796600022100
Closed	00796600022300
Closed	00796600022400
Closed	00796600022500
Closed	00796600022700
Closed	00840500000300
Closed	00604900001901
Closed	00604900001902
Closed	00604900001903
Closed	00840500000500
Closed	00840500000600
Closed	00840500000700
Closed	00840500000800
Closed	00840500001300
Closed	00840500001400
Closed	00796600019700
Closed	00796600019800
Closed	00796600019900
Closed	00796600018600
Closed	00796600019100
Closed	00796600019200
Closed	00796600019500
Closed	29063600102000
Closed	27051000407700
Closed	27051000407900
Closed	00422500004800
Closed	00796600017200
Closed	00796600017300
Closed	00796600017400
Closed	00796600017600
Closed	00796600017700
Closed	00796600017900
Closed	00796600018000
Closed	00796600018100
Closed	00839100000900
Closed	30060800103600
Closed	00492000301901
Closed	29070800400400
Closed	00839200001600
Closed	00839200001700
Closed	00839200001300
Closed	00839200001400
Closed	00839200001500
Closed	00839200001900

Accessory Dwelling Units

Index # - File Name: 1.0022 - Single Family Dwellings Data\_Snohomish County.pdf

Closed	00839200002000
Closed	00839200002300
Closed	00839200002500
Closed	00839200002600
Closed	00839200002700
Closed	00839200002800
Closed	00839200002900
Closed	00839200003100
Closed	00839200003200
Closed	00839200003400
Closed	00839200004100
Closed	00796600014400
Closed	00796600014500
Closed	00796600014600
Closed	00796600014700
Closed	00796600014800
Closed	00796600014900
Closed	00796600015000
Closed	00796600015100
Closed	00796600015200
Closed	00796600015500
Closed	00796600015400
Closed	00796600015600
Closed	00796600015700
Closed	00796600015800
Closed	00796600015900
Closed	00796600016000
Closed	00796600016100
Closed	00796600016200
Closed	00796600016300
Closed	00796600016400
Closed	00796600016500
Closed	00796600016600
Closed	00796600016700
Closed	00796600016800
Closed	00796600016900
Closed	00796600017000
Closed	00839200000900
Closed	00839200001000
Closed	00839200001100
Closed	00839100000600
Closed	00839000000400
Closed	00839000000500
Closed	00839000000700
Closed	31043100400900
Closed	29062300302100
Closed	32090700100200



Accessory Dwelling Units

Index # - File Name: 1.0022 - Single Family Dwellings Data\_Snohomish County.pdf

Closed	28051200201700
Closed	28051200100600
Closed	27062900401900
Closed	00394406301200
Closed	00838800005000
Closed	00838800008800
Closed	00838800009000
Closed	00838800006200
Closed	00838800006300
Closed	00838800006800
Closed	00838800006900
Closed	00838800007500
Closed	00838800007600
Closed	00838800007700
Closed	00838800008000
Closed	00838800008100
Closed	00838800008200
Closed	00838800008300
Closed	00838800008400
Closed	00838800008500
Closed	00838800008600
Closed	00838800005200
Closed	00838800005300
Closed	00838800005500
Closed	00838800005600
Closed	00838800005700
Closed	00838800005800
Closed	00838800005900
Closed	00838800004800
Closed	00838800002300
Closed	00838800002400
Closed	00838800001600
Closed	00838800001700
Closed	00838800001900
Closed	00838800002000
Closed	00838800003200
Closed	00838800003300
Closed	00838800003900
Closed	00838800004200
Closed	00838800000900
Closed	00838800001000
Closed	00838800001100
Closed	00838200000100
Closed	00838200000200
Closed	00838200000300
Closed	00838200000500
Closed	00836500007000

Accessory Dwelling Units

Index # - File Name: 1.0022 - Single Family Dwellings Data\_Snohomish County.pdf

Closed	00838200000800
Closed	00796600012500
Closed	00796600012600
Closed	00796600012700
Closed	00796600012900
Closed	00796600013000
Closed	00796600013100
Closed	00796600013200
Closed	00796600013300
Closed	00796600013400
Closed	00796600013500
Closed	00796600013600
Closed	00796600013800
Closed	00796600013900
Closed	00796600014000
Closed	00796600014100
Closed	00796600014200
Closed	00796600014300
Closed	00838800000100
Closed	00838800000300
Closed	00836500004000
Closed	00836500002100
Closed	00836500002400
Closed	00836500002500
Closed	00836500003000
Closed	00836500005900
Closed	00836500006200
Closed	00836500006500
Closed	00836500000800
Closed	00836500001100
Closed	00836500001400
Closed	00836500001600
Closed	00836500001700
Closed	00836500000100
Closed	00836500000200
Closed	00836500000300
Closed	29060600201200
Closed	29060600202400
Closed	00837600009800
Closed	00837600010300
Closed	00837600009000
Closed	00837600009100
Closed	00837600006200
Closed	00837600006300
Closed	00837600006600
Closed	00589600005600
Closed	00490400003400

Accessory Dwelling Units

Index # - File Name: 1.0022 - Single Family Dwellings Data\_Snohomish County.pdf

Closed	32063200301400
Closed	32063500200400
Closed	32063500201200
Closed	00569000001003
Closed	00569000001002
Closed	00795100001200
Closed	27062100403500
Closed	00494600301006
Closed	00373001201707
Closed	00483000004200
Closed	00813000000100
Closed	00813000000600
Closed	00807900000100
Closed	32052200304000
Closed	00823400004500
Closed	00823400000800
Closed	00823400000900
Closed	30040300200500
Closed	00373800600802
Closed	00489800000700
Closed	00823400005400
Closed	00823400005500
Closed	00823400005600
Closed	00823400006100
Closed	00823400006200
Closed	00823400006300
Closed	00823400006400
Closed	00823400006500
Closed	00823400006600
Closed	00823400004800
Closed	00823400004900
Closed	00823400006800
Closed	00823400007200
Closed	00823400007300
Closed	00823400007400
Closed	30042300302900
Closed	30042300303200
Closed	00823300014300
Closed	00823300014400
Closed	00823300014500
Closed	00823300009600
Closed	00823300014000
Closed	00823300011200
Closed	00823300011400
Closed	00823300006600
Closed	00823300006700
Closed	00823300006800

Accessory Dwelling Units

Index # - File Name: 1.0022 - Single Family Dwellings Data\_Snohomish County.pdf

Closed	00823300007000
Closed	00823300003700
Closed	32052100101900
Closed	29061700307900
Closed	32053200304700
Closed	00823300001200
Closed	00817800000900
Closed	00817800000400
Closed	00817800000500
Closed	30042300400400
Closed	27052800306400
Closed	00802400005200
Closed	32090900301200
Closed	30072100300300
Closed	29061400102200
Closed	00825700000600
Closed	00825700000900
Closed	00825700001400
Closed	00489800000800
Closed	00394510600100
Closed	00824400000800
Closed	31052400401200
Closed	00824400001100
Closed	00823400009600
Closed	00823400013400
Closed	00823400007000
Closed	00827400000100
Closed	00394511000801
Closed	00830500000200
Closed	00828800005900
Closed	00828800006100
Closed	30062100200800
Closed	00827600001400
Closed	00827400000500
Closed	32080300400500
Closed	00828500002900
Closed	00828800002900
Closed	00828800003200
Closed	00828800003300
Closed	00828800003600
Closed	00830500008500
Closed	00830600000400
Closed	00830700000400
Closed	00830700001000
Closed	00830700001200
Closed	00831200001100
Closed	00831200001300

Accessory Dwelling Units

Index # - File Name: 1.0022 - Single Family Dwellings Data\_Snohomish County.pdf

Closed	00831200001600
Closed	00831200001900
Closed	00831200002500
Closed	00831200002700
Closed	00831200002900
Closed	00831200003000
Closed	00831200003200
Closed	00831200004900
Closed	00831200005000
Closed	00831200005100
Closed	00831200005200
Closed	00831200005700
Closed	00831200006000
Closed	00831200006100
Closed	00831200006400
Closed	00831200006500
Closed	00831200006800
Closed	00831200006900
Closed	00831200007100
Closed	00831200007200
Closed	00831200007300
Closed	00831200007400
Closed	00830500002800
Closed	00830500002300
Closed	00830500002400
Closed	00830500003800
Closed	00830500003900
Closed	00830500004000
Closed	00830500005400
Closed	00830500005500
Closed	00830500005600
Closed	00830500005700
Closed	00830500005800
Closed	00830500005900
Closed	00830500006000
Closed	00830500006100
Closed	00830500006200
Closed	00830500003100
Closed	00830500003200
Closed	00830500007900
Closed	00830500008000
Closed	00830500008100
Closed	00830500008200
Closed	30061900400800
Closed	32052000300600
Closed	00537800001705
Closed	00831300000600

Accessory Dwelling Units

Index # - File Name: 1.0022 - Single Family Dwellings Data\_Snohomish County.pdf

Closed	00831200008200
Closed	00831200008400
Closed	00831200004500
Closed	00831200004600
Closed	00831200004700
Closed	00832300001800
Closed	00471600000200
Closed	00832300000800
Closed	00832300001000
Closed	00832300001500
Closed	00831700000700
Closed	00831700000800
Closed	31062700100200
Closed	31063200100700
Closed	00837600002800
Closed	00837700001300
Closed	00837700001400
Closed	29060400101500
Closed	31043000200700
Closed	32042300101800
Closed	00532000002400
Closed	00837100006100
Closed	00837100006200
Closed	00837100006300
Closed	00837100006400
Closed	00837100000100
Closed	00837100000500
Closed	00837100000700
Closed	00837100000800
Closed	00837100001100
Closed	00837100001200
Closed	00837100001300
Closed	00837100001400
Closed	00837100001500
Closed	00837100001600
Closed	00837100001700
Closed	00837100001800
Closed	00837100001900
Closed	00837100002000
Closed	00837100002100
Closed	00837100002200
Closed	00837100002300
Closed	00837100002400
Closed	00837100002900
Closed	00483000002700
Closed	00836800001500
Closed	00836800001900

Accessory Dwelling Units

Index # - File Name: 1.0022 - Single Family Dwellings Data\_Snohomish County.pdf

Closed	31063100202000
Closed	32063200303800
Closed	32063200303900
Closed	32063200304000
Closed	27053500103700
Closed	31041300402100
Closed	27051100203600
Closed	00617000003600
Closed	28082000402000
Closed	00836800000500
Closed	00836000001300
Closed	30081500400900
Closed	00833200000200
Closed	32060400400600
Closed	27062200301900
Closed	27060500100900
Closed	00835300002300
Closed	00835300002400
Closed	00835300002500
Closed	00835300000900
Closed	00835200000800
Closed	00835200000900
Closed	00835300000500
Closed	00835200000500
Closed	00835200000600
Closed	31062800201100
Closed	00835200000300
Closed	00835200000100
Closed	00593300000503
Closed	30062000400800
Closed	00835700000300
Closed	00836000000200
Closed	30052100111200
Closed	32052400101300
Closed	32040800302200
Closed	00960001501600
Closed	00509300001402
Closed	00509300001403
Closed	00509300001404
Closed	29062300200400
Closed	31053300203600
Closed	00569000004102
Closed	00859500000100
Closed	00859500000200
Closed	00859500000300
Closed	00859500000400
Closed	00859500000500

Accessory Dwelling Units

Index # - File Name: 1.0022 - Single Family Dwellings Data\_Snohomish County.pdf

Closed	00859500000600
Closed	00859500000700
Closed	00859500000800
Closed	00859500000900
Closed	00859500001000
Closed	00859500001100
Closed	00537800001603
Closed	00537800001604
Closed	00537800001605
Closed	30063600400800
Closed	00394404500700
Closed	30043600300900
Closed	28062200100300
Closed	27063200402000
Closed	00805000001000
Closed	32042700402500
Closed	00594300000602
Closed	00431400100204
Closed	29060200200900
Closed	00960003900700
Closed	28062300102900
Closed	32072900301900
Closed	30040100200100
Closed	00860100000300
Closed	00860100000500
Closed	00860100000600
Closed	00960003902400
Closed	00500700100700
Closed	00385800000202
Closed	29060900402000
Closed	29060900402100
Closed	28071800101300
Closed	30052100102600
Closed	00394402001500
Closed	00394402001800
Closed	00394402005500
Closed	00858400000200
Closed	00858400000300
Closed	00858400000600
Closed	00858400000700
Closed	00858400000800
Closed	00858400000900
Closed	00858400001000
Closed	00858400001300
Closed	00858400001400
Closed	00494511301602
Closed	29070500400200



Accessory Dwelling Units

Index # - File Name: 1.0022 - Single Family Dwellings Data\_Snohomish County.pdf

Closed	00858300000100
Closed	00858300000200
Closed	00858300000300
Closed	00858300000400
Closed	00858300000500
Closed	00494511301503
Closed	00494511301600
Closed	00858700000200
Closed	00858700000400
Closed	00858700000500
Closed	00858700000700
Closed	00858700000800
Closed	00858700000900
Closed	00858700001600
Closed	28060800401300
Closed	00858700001200
Closed	00858700002800
Closed	00858700002900
Closed	00858700003000
Closed	00858700003100
Closed	32042100101900
Closed	32042100102000
Closed	32042100102100
Closed	32042100102200
Closed	30050600402000
Closed	31043100200800
Closed	31043100200900
Closed	28071000300800
Closed	00385700702102
Closed	32052200201000
Closed	30061400101900
Closed	30061400102000
Closed	32040400103300
Closed	00394405201200
Closed	32061500201000
Closed	00859100000100
Closed	00859100000200
Closed	00859100000400
Closed	00859100000500
Closed	27062000100400
Closed	31043000400100
Closed	31053300401200
Closed	31041000102700
Closed	00960003900100
Closed	00960003900400
Closed	00960003901500
Closed	00960003902600

Accessory Dwelling Units

Index # - File Name: 1.0022 - Single Family Dwellings Data\_Snohomish County.pdf

Closed	31061700400300
Closed	27063500201600
Closed	27062900102700
Closed	31063500301200
Closed	00860100000200
Closed	00394401500005
Closed	00520200005300
Closed	00860600000100
Closed	00860600000200
Closed	00860600000300
Closed	00860600000500
Closed	00860600000600
Closed	00860600000700
Closed	00860600000800
Closed	00860600000900
Closed	00860600001000
Closed	00860600001100
Closed	00509300003003
Closed	00509300003002
Closed	00509300003004
Closed	00860900000100
Closed	00860900000300
Closed	00860900000400
Closed	00860900000500
Closed	00860900000600
Closed	00860900000700
Closed	00860900000800
Closed	00860900000900
Closed	00860900001000
Closed	00860900001100
Closed	00860900001200
Closed	00860900001300
Closed	00860900001400
Closed	00860900001500
Closed	00860900001600
Closed	00860900001800
Closed	00860900001900
Closed	00860900002000
Closed	00860900002100
Closed	00860900002200
Closed	00860900002300
Closed	00860900002400
Closed	00860900002500
Closed	30051400200700
Closed	00394400505500
Closed	30060700202500
Closed	00861100000900

Accessory Dwelling Units

Index # - File Name: 1.0022 - Single Family Dwellings Data\_Snohomish County.pdf

Closed	00861100001000
Closed	00861100000600
Closed	00861100002800
Closed	00861100003400
Closed	00861100003100
Closed	00861100003200
Closed	00861100004100
Closed	00861100004300
Closed	00861100004400
Closed	00861300000100
Closed	00861300000200
Closed	00861300000300
Closed	00861300000400
Closed	00861300000500
Closed	00861300000600
Closed	00861300000700
Closed	00861300000800
Closed	00861300000900
Closed	00861300001000
Closed	00861300001100
Closed	00861300001200
Closed	00861300001300
Closed	00861300001400
Closed	00861300001500
Closed	00861300001600
Closed	00861300001700
Closed	00861300001800
Closed	00861300001900
Closed	00861300002000
Closed	00960003012200
Closed	00372801200805
Closed	00372801200806
Closed	00861100004900
Closed	32062100201700
Closed	28072900303400
Closed	31053300401200
Closed	00861700100300
Closed	00861700100800
Closed	00861700101200
Closed	00861700100500
Closed	00568800200505
Closed	00960003902000
Closed	00862100000300
Closed	28060300301600
Closed	31063300101900
Closed	00597400001107
Closed	31060800200600

Accessory Dwelling Units

Index # - File Name: 1.0022 - Single Family Dwellings Data\_Snohomish County.pdf

Closed	27072900401400
Closed	00851100001700
Closed	00851100002000
Closed	00851100002400
Closed	00851100000300
Closed	00851100000400
Closed	00851100000500
Closed	00851100000600
Closed	00851100000700
Closed	00851100000800
Closed	00851100000900
Closed	00851100001100
Closed	00851100001200
Closed	00850200001100
Closed	00490400002500
Closed	00603100200101
Closed	31043000300700
Closed	27062700402300
Closed	00466500003800
Closed	31043200200600
Closed	00851000000200
Closed	00851000000300
Closed	00851000000400
Closed	00851000000500
Closed	00851000000600
Closed	00851000000700
Closed	00851000000800
Closed	00851000000900
Closed	00851000001000
Closed	00851000001100
Closed	00851000001200
Closed	00851000001300
Closed	00851000001400
Closed	00851000001500
Closed	00851000001700
Closed	00851000001900
Closed	00851000002100
Closed	00851000002200
Closed	00851000002300
Closed	00851000002400
Closed	00851000002500
Closed	00851000002600
Closed	00851000002700
Closed	00851000002800
Closed	00851000002900
Closed	00851000003000
Closed	00851000003100

Accessory Dwelling Units

Index # - File Name: 1.0022 - Single Family Dwellings Data\_Snohomish County.pdf

Closed	00851000003200
Closed	00851000003300
Closed	00851000003400
Closed	00851000003500
Closed	00851000003600
Closed	00851000003700
Closed	00851000003800
Closed	00851000003900
Closed	00851000004000
Closed	00851000004100
Closed	00851000004200
Closed	00851000004300
Closed	00851000004400
Closed	00851000004500
Closed	00851000004600
Closed	00851000004700
Closed	00851000004800
Closed	00851000004900
Closed	00851000005000
Closed	00851000005100
Closed	00851000005300
Closed	00851000005400
Closed	00851000005500
Closed	00851000005600
Closed	00851100002600
Closed	00851100002700
Closed	00851100002800
Closed	29051100101500
Closed	00577600200400
Closed	28072300100300
Closed	00492000108300
Closed	27052100100900
Closed	00652300000100
Closed	00738100000100
Closed	30050200102300
Closed	00376800003801
Closed	00960013305900
Closed	00491400300108
Closed	00590700002800
Closed	27052600402000
Closed	00851700000100
Closed	00851700000200
Closed	00851700000300
Closed	00851700000400
Closed	00851700000500
Closed	00851700000600
Closed	00851700000700

Accessory Dwelling Units

Index # - File Name: 1.0022 - Single Family Dwellings Data\_Snohomish County.pdf

Closed	00851700000800
Closed	00851700000900
Closed	00851700001000
Closed	00851700001100
Closed	00851700001200
Closed	00851700001300
Closed	00851700001400
Closed	00851700001500
Closed	00851700001600
Closed	00851700001700
Closed	00851700001800
Closed	00384200000200
Closed	00459900400900
Closed	30052300201700
Closed	28073000303100
Closed	28073000303200
Closed	00480000006100
Closed	00373300300103
Closed	00466900005000
Closed	00394401203100
Closed	30060500401400
Closed	00557600002400
Closed	00396500002200
Closed	31053300401200
Closed	00394404407400
Closed	00403800003500
Closed	00960003902800
Closed	28073500202900
Closed	32063100100100
Closed	32061200400700
Closed	28073100402900
Closed	31050300201300
Closed	30071900202200
Closed	00852700000100
Closed	00852700000200
Closed	00852700000300
Closed	00852700000400
Closed	00852700000500
Closed	00852700000600
Closed	00852700000700
Closed	00852700001000
Closed	00852700001100
Closed	00852700001200
Closed	00852700001300
Closed	00852700001400
Closed	00852700001600
Closed	00852700001700

Accessory Dwelling Units

Index # - File Name: 1.0022 - Single Family Dwellings Data\_Snohomish County.pdf

Closed	00852700001800
Closed	00852700001900
Closed	00852700002100
Closed	00852700002400
Closed	00852700002500
Closed	00852700002900
Closed	00852700003000
Closed	00852700003600
Closed	00852700003800
Closed	00852700004100
Closed	00852700004200
Closed	00852700004500
Closed	00852700004600
Closed	00852700004800
Closed	00852700005000
Closed	00852700005100
Closed	00852700005200
Closed	00852700005300
Closed	00852700005400
Closed	00852700005500
Closed	00852700005600
Closed	00852700005700
Closed	00852700005900
Closed	00852700006200
Closed	00852700006300
Closed	00852800001100
Closed	00748800000100
Closed	30071600300300
Closed	00385500200301
Closed	27053300103600
Closed	30051000204700
Closed	00853300000100
Closed	00853300000200
Closed	00853300000300
Closed	00853300000400
Closed	00853300000500
Closed	00853300000600
Closed	00853300000700
Closed	00853300000800
Closed	00853300000900
Closed	00853300001000
Closed	00853300001300
Closed	00960012002800
Closed	00853300001700
Closed	00853300001900
Closed	00853300002700
Closed	00853300003100

Accessory Dwelling Units

Index # - File Name: 1.0022 - Single Family Dwellings Data\_Snohomish County.pdf

Closed	00853300003300
Closed	00853500002100
Closed	00853500002200
Closed	00853500002300
Closed	00853500002400
Closed	00853500002500
Closed	00853500002600
Closed	00853500002700
Closed	00853500002800
Closed	00853500002900
Closed	00853500003000
Closed	00853500003100
Closed	00853500003200
Closed	00853500003300
Closed	00853500003400
Closed	00853500003500
Closed	00853500003600
Closed	00853500003700
Closed	00853500003800
Closed	00853500003900
Closed	00853500004000
Closed	00853500004100
Closed	00853500004200
Closed	00853500004300
Closed	00853500004400
Closed	00853500004500
Closed	00853500004600
Closed	00853500004700
Closed	00853500004800
Closed	00853500004900
Closed	00853500005000
Closed	00853500005100
Closed	00853500005200
Closed	00853500005300
Closed	00853500005400
Closed	00853500005500
Closed	00853500005600
Closed	00853500005700
Closed	00850200000100
Closed	00850200000300
Closed	00850200000500
Closed	00429000000500
Closed	00385600200902
Closed	00385600200903
Closed	00385600200904
Closed	30060800201800
Closed	00585200005603



Accessory Dwelling Units

Index # - File Name: 1.0022 - Single Family Dwellings Data\_Snohomish County.pdf

Closed	00960003901800
Closed	32050900201900
Closed	00850900001200
Closed	00850900001400
Closed	00850900001500
Closed	00850900001800
Closed	00850800000100
Closed	00850800000200
Closed	00850800000300
Closed	00850800000400
Closed	00850800000600
Closed	00850800000700
Closed	00850800001000
Closed	00850800001100
Closed	00850800001200
Closed	00850800001300
Closed	00850800001400
Closed	00850800001500
Closed	00850800001700
Closed	00850800001800
Closed	00850800002000
Closed	00850800002100
Closed	00850800002400
Closed	00850800002500
Closed	00850800002600
Closed	00850800002800
Closed	00850800002900
Closed	00850800003000
Closed	00850800003200
Closed	00850800003300
Closed	00850800003500
Closed	00850800003600
Closed	00850800003700
Closed	00850700000100
Closed	00850700000400
Closed	00850700000500
Closed	00850700000700
Closed	00850700000900
Closed	00850700001000
Closed	00850700001200
Closed	00850700001400
Closed	00850700001500
Closed	00850700001600
Closed	00850700002200
Closed	00850700002400
Closed	00849500003800
Closed	00849500004300

Accessory Dwelling Units

Index # - File Name: 1.0022 - Single Family Dwellings Data\_Snohomish County.pdf

Closed	00849500004400
Closed	00849500004600
Closed	00849500004700
Closed	00849500004800
Closed	00849500004900
Closed	00849500005000
Closed	00849500005100
Closed	00849500005300
Closed	00849500005400
Closed	00849500005500
Closed	00849500005600
Closed	00849500005700
Closed	00849500005800
Closed	00849700000100
Closed	00849700000300
Closed	00849700000500
Closed	00849700000800
Closed	00849600001100
Closed	00849600001300
Closed	00849600001600
Closed	00849600001800
Closed	00849600000100
Closed	00849600000300
Closed	31043000201200
Closed	00849800001000
Closed	00849800001500
Closed	00849800001700
Closed	00849800002100
Closed	00849800002200
Closed	00849800002300
Closed	00849800002400
Closed	00849800002700
Closed	00849800002800
Closed	00849800003000
Closed	00849800003100
Closed	00849800003300
Closed	00849800003400
Closed	00849800004300
Closed	00849800004500
Closed	00849800004800
Closed	00849800005100
Closed	00849800005400
Closed	00849800005500
Closed	00590700017905
Closed	00849500000100
Closed	00849500000200
Closed	00849500000300

Accessory Dwelling Units

Index # - File Name: 1.0022 - Single Family Dwellings Data\_Snohomish County.pdf

Closed	00849500000400
Closed	00849500000500
Closed	00849500000600
Closed	00849500000700
Closed	00849500000800
Closed	00849500000900
Closed	00849500001000
Closed	00849500001100
Closed	00849500001300
Closed	00849500001400
Closed	00849500001600
Closed	00849500001700
Closed	00849600000600
Closed	00600200000403
Closed	32052200301000
Closed	32061500201600
Closed	32042500301900
Closed	29051300105900
Closed	29051300102300
Closed	27062300300200
Closed	32040400102600
Closed	29052600102100
Closed	29060500102800
Closed	00637600001500
Closed	32063300402400
Closed	00848800000100
Closed	00848800000200
Closed	00848800000400
Closed	00848800000500
Closed	00848800000700
Closed	00848800000900
Closed	00848800001100
Closed	00848800001200
Closed	00848800001400
Closed	00848800001600
Closed	00848800001700
Closed	00848800001900
Closed	00848800002000
Closed	00848800002200
Closed	00848800002300
Closed	00848800002400
Closed	00848800002500
Closed	00848800002600
Closed	00848800002900
Closed	00848800003100
Closed	00848800003200
Closed	00848800003300

Accessory Dwelling Units

Index # - File Name: 1.0022 - Single Family Dwellings Data\_Snohomish County.pdf

Closed	00848800003400
Closed	00848800003500
Closed	00848800003600
Closed	00848800003900
Closed	00848800004000
Closed	00848800004100
Closed	00848800004200
Closed	00848800004300
Closed	00848800004900
Closed	00848800005100
Closed	00848800005300
Closed	00848800005400
Closed	00848800005500
Closed	00848800005600
Closed	00848800005700
Closed	00848800005800
Closed	00848800005900
Closed	00848800006000
Closed	00848800006100
Closed	00848800006200
Closed	00848800006300
Closed	00848800006600
Closed	00848800006800
Closed	00848800007000
Closed	00848800007200
Closed	00848800007300
Closed	00848800007400
Closed	00848800007500
Closed	00848800007700
Closed	00848800007800
Closed	00848800007900
Closed	00848800008000
Closed	00848800008100
Closed	00848800008800
Closed	00848800009300
Closed	00848800009400
Closed	00848800009500
Closed	00848800009600
Closed	00848800009700
Closed	00848800009800
Closed	00848800009900
Closed	00848800010000
Closed	00848800010200
Closed	28071500300500
Closed	00394404302400
Closed	00394404302700
Closed	00394404303000

Accessory Dwelling Units

Index # - File Name: 1.0022 - Single Family Dwellings Data\_Snohomish County.pdf

Closed	31053300401200
Closed	28060400100700
Closed	30070100200300
Closed	00457100003504
Closed	00457100003506
Closed	00457100003507
Closed	00499100202300
Closed	30062800302700
Closed	28060800202500
Closed	27071100201100
Closed	00960003900500
Closed	00802400002900
Closed	00482900000800
Closed	30060400201000
Closed	27070300102200
Closed	00802400003000
Closed	28071800300600
Closed	30052200210600
Closed	00577700603300
Closed	32043600401800
Closed	00960003902100
Closed	32072900302200
Closed	31043000202200
Closed	00403800006403
Closed	00855100000100
Closed	00855100000200
Closed	00855100000300
Closed	00855100000500
Closed	00855100000700
Closed	00855100000800
Closed	00855100000900
Closed	00855100001000
Closed	00855100001100
Closed	00855100001200
Closed	00855100001300
Closed	00855100001500
Closed	00855100001600
Closed	00855100001700
Closed	00373701003400
Closed	00854300000100
Closed	00854300000200
Closed	00854300000300
Closed	00854300000400
Closed	00854300000500
Closed	00854300000600
Closed	00854300000700
Closed	00854300000800

Accessory Dwelling Units

Index # - File Name: 1.0022 - Single Family Dwellings Data\_Snohomish County.pdf

Closed	00854300000900
Closed	00854300001000
Closed	00854300001100
Closed	00854300001200
Closed	00854300001300
Closed	00854300001400
Closed	00854300001500
Closed	00854300001600
Closed	00854300001700
Closed	00854300001800
Closed	00854300001900
Closed	00854300002000
Closed	00854300002100
Closed	00854300002200
Closed	00854300002300
Closed	00854300002400
Closed	00854300002500
Closed	00854300002600
Closed	00854300002700
Closed	00854300002800
Closed	00854300002900
Closed	00483000006100
Closed	31060600301700
Closed	00403900017701
Closed	00409500000900
Closed	00480000005600
Closed	00394406401100
Closed	00559900003200
Closed	30040600100100
Closed	00854600000500
Closed	00854600000600
Closed	00854600000700
Closed	00854600000800
Closed	00854600000900
Closed	00854600001000
Closed	00854600001100
Closed	00854600001200
Closed	00854600001300
Closed	00854600001400
Closed	00854600001500
Closed	00854600001600
Closed	00854600001700
Closed	00854600001800
Closed	29061200301800
Closed	32042500401300
Closed	32042500400800
Closed	32042500400700

Accessory Dwelling Units

Index # - File Name: 1.0022 - Single Family Dwellings Data\_Snohomish County.pdf

Closed	30060200300200
Closed	00577700603200
Closed	00467000004700
Closed	31043000201400
Closed	31053300401200
Closed	29062200303500
Closed	31043100101500
Closed	31043100101600
Closed	00394405101701
Closed	00464300000700
Closed	31043000201800
Closed	00577600200500
Closed	27052600402200
Closed	00466200002300
Closed	31060600301900
Closed	31043000301000
Closed	31060700200600
Closed	00491400300107
Closed	29053600101200
Closed	30073100300700
Closed	00394406500100
Closed	00853600003400
Closed	00853600003500
Closed	00960003001300
Closed	00960003003800
Closed	31062900202500
Closed	31062900202600
Closed	31062900202700
Closed	00570400200603
Closed	30063500300700
Closed	00960002700800
Closed	28071600105900
Closed	00852900000200
Closed	00374100500602
Closed	30060200300800
Closed	00541700001101
Closed	30051400103400
Closed	00853300005200
Closed	00853300005300
Closed	00853300005500
Closed	00853300005600
Closed	00853300005700
Closed	00853300005900
Closed	00853300006000
Closed	00853300006200
Closed	00853400000100
Closed	00853400000200

Accessory Dwelling Units

Index # - File Name: 1.0022 - Single Family Dwellings Data\_Snohomish County.pdf

Closed	0085340000300
Closed	00853300002900
Closed	00853300003700
Closed	00853300004300
Closed	00853500006000
Closed	00853500006100
Closed	00853300004700
Closed	00853300004000
Closed	00853300004100
Closed	00853600001000
Closed	00853600001400
Closed	00853600001800
Closed	00853600002100
Closed	00853600002300
Closed	00853600002400
Closed	00853600002500
Closed	30040300303000
Closed	00960013304400
Closed	00577600201600
Closed	00855300002200
Closed	00855300002300
Closed	00855300002500
Closed	00855300002600
Closed	00855300002700
Closed	00855300002800
Closed	00855300002900
Closed	00855300000100
Closed	00855300000200
Closed	00855300000300
Closed	00855300000400
Closed	00855300000500
Closed	00855300000600
Closed	00855300000700
Closed	00855300000800
Closed	00855300000900
Closed	00855300001000
Closed	00855300001100
Closed	00855300001200
Closed	00855300001300
Closed	00855300001500
Closed	00855300001600
Closed	00855300001700
Closed	00855300001800
Closed	00855300001900
Closed	32042100101500
Closed	00855200000100
Closed	00855200000200



Accessory Dwelling Units

Index # - File Name: 1.0022 - Single Family Dwellings Data\_Snohomish County.pdf

Closed	00855200000300
Closed	00855200000400
Closed	00855200000500
Closed	00855200000600
Closed	00855200000700
Closed	00855200000800
Closed	00855200000900
Closed	00855200001000
Closed	00855200001100
Closed	00855200001200
Closed	00855200001300
Closed	00855200001400
Closed	00855200001500
Closed	00855200001600
Closed	00855200001700
Closed	00855200001800
Closed	00855200001900
Closed	00855200002000
Closed	00854800000200
Closed	00854800000300
Closed	00854800000400
Closed	00854800000500
Closed	00855100002500
Closed	00960003901100
Closed	28060200101300
Closed	28072900302800
Closed	00376900000200
Closed	00855300003100
Closed	00855300003200
Closed	00855300003400
Closed	00855300003800
Closed	00855300004200
Closed	00855300004300
Closed	00855300004400
Closed	29061600304000
Closed	00374800005802
Closed	00374800005804
Closed	00374800005805
Closed	28062400300300
Closed	00490500003000
Closed	00490500003100
Closed	27061800202400
Closed	28061500202400
Closed	00617300200900
Closed	32061000200400
Closed	00513100000301
Closed	00394406201601

Accessory Dwelling Units

Index # - File Name: 1.0022 - Single Family Dwellings Data\_Snohomish County.pdf

Closed	27070400202500
Closed	00856500000100
Closed	00856500000200
Closed	00856500000500
Closed	00856500000600
Closed	00856500000700
Closed	00856500000800
Closed	00856500000900
Closed	00856500001000
Closed	00856500001100
Closed	00856500001500
Closed	28073000104400
Closed	28073000104700
Closed	28073000104900
Closed	27090500202700
Closed	00394406400800
Closed	32052200201400
Closed	00385300009600
Closed	32053200204800
Closed	31053300401200
Closed	32040900200900
Closed	28072500202300
Closed	00511900101701
Closed	00489100006700
Closed	00509500006401
Closed	28051200101600
Closed	32040600200800
Closed	00594900001101
Closed	00594900001103
Closed	00594900001104
Closed	32063300400400
Closed	00480000012800
Closed	30042600401300
Closed	00394401702500
Closed	30040700400600
Closed	00394510600400
Closed	30040100200400
Closed	29062300301400
Closed	00492900000701
Closed	30052200403900
Closed	30052200404100
Closed	30052200404400
Closed	31053300401200
Closed	00482900005400
Closed	00960003903400
Closed	29061200302500
Closed	27062000402500

Accessory Dwelling Units

Index # - File Name: 1.0022 - Single Family Dwellings Data\_Snohomish County.pdf

Closed	31040500401500
Closed	32070800103400
Closed	00442900201601
Closed	00960001506800
Closed	31043000300300
Closed	31061800400200
Closed	00511900101702
Closed	00529800001900
Closed	00537800002501
Closed	32072900302300
Closed	00480401705401
Closed	31053300203600
Closed	00857800000200
Closed	00857800000300
Closed	00857800000500
Closed	00857800000600
Closed	00857800000700
Closed	00857800000800
Closed	00857800000900
Closed	00857900000200
Closed	00857900000400
Closed	00857900000500
Closed	00857900000600
Closed	00857900000700
Closed	00857900000800
Closed	00857800001200
Closed	00394406401301
Closed	27063300301000
Closed	28062200403000
Closed	00491900601400
Closed	00831200005800
Closed	00397700002101
Closed	00802400003100
Closed	00400500000107
Closed	00384200000700
Closed	30050900106600
Closed	30050900106700
Closed	30050900106800
Closed	30050900106900
Closed	30052200211300
Closed	31043400403300
Closed	32060900401400
Closed	00509300002801
Closed	00857900000100
Closed	00490400000400
Closed	00857800001100
Closed	00394403503800

Accessory Dwelling Units

Index # - File Name: 1.0022 - Single Family Dwellings Data\_Snohomish County.pdf

Closed	00960001501800
Closed	00459900301400
Closed	27062000402500
Closed	28051600200800
Closed	27073000200800
Closed	00489100006200
Closed	00489700200700
Closed	32090800100700
Closed	32063200400800
Closed	31052300302300
Closed	00509200202102
Closed	31050900201200
Closed	28060400400100
Closed	00489100005700
Closed	00396500009200
Closed	00856500001300
Closed	00856500001400
Closed	00856500000300
Closed	00856500000400
Closed	31043000201600
Closed	27061800202500
Closed	27061800202300
Closed	00394406401000
Closed	32073000300900
Closed	32073000302000
Closed	31032500400600
Closed	29061200301900
Closed	00882900001400
Closed	00882900000200
Closed	00882900000300
Closed	00882900000600
Closed	00882900001000
Closed	00882900001300
Closed	00882900000400
Closed	00882900000500
Closed	00882900000800
Closed	00882900001100
Closed	00855300003900
Closed	00855300004100
Closed	00855300003500
Closed	00855300003600
Closed	00855300003300
Closed	00376900000300
Closed	27071100300300
Closed	00854800000100
Closed	00513700003301
Closed	00855300002000

Accessory Dwelling Units

Index # - File Name: 1.0022 - Single Family Dwellings Data\_Snohomish County.pdf

Closed	00855300003000
Closed	00882900000100
Closed	00394406400106
Closed	00853300003600
Closed	00853600003100
Closed	00853600003200
Closed	00853600002200
Closed	00853600001900
Closed	00853600002000
Closed	00853600001600
Closed	00853600000700
Closed	00853600000800
Closed	00853600000900
Closed	00853600001100
Closed	00853300004200
Closed	00853600000500
Closed	00853300004900
Closed	00853300005000
Closed	00853300005100
Closed	00853600000100
Closed	00853500006200
Closed	00853500006500
Closed	00853500006600
Closed	00853500006900
Closed	00853500007000
Closed	00853500007100
Closed	00853500007200
Closed	00853500007500
Closed	00853500007600
Closed	00853500007700
Closed	00853500007800
Closed	00853300004400
Closed	00853300004500
Closed	00853300004600
Closed	00853300003800
Closed	00853300003900
Closed	00853500000200
Closed	00853500000300
Closed	00853500000400
Closed	00853500000500
Closed	00853500000600
Closed	00853500000700
Closed	00853500000800
Closed	00853500000900
Closed	00853500001000
Closed	00853500001100
Closed	00853500001200

Accessory Dwelling Units

Index # - File Name: 1.0022 - Single Family Dwellings Data\_Snohomish County.pdf

Closed	00853500001300
Closed	00853500001400
Closed	00853500001500
Closed	00853500001600
Closed	00853500001700
Closed	00853500001800
Closed	00853500001900
Closed	00853500002000
Closed	30051400103200
Closed	30051400100500
Closed	00372800900500
Closed	00853600003700
Closed	31051800400100
Closed	31040900301300
Closed	00551500010500
Closed	27061600300800
Closed	31043000201500
Closed	29071800300700
Closed	29071800300800
Closed	00381400002700
Closed	27062700300500
Closed	00855100001800
Closed	00855100001900
Closed	00855100002000
Closed	00855100002100
Closed	00855100002200
Closed	00855100002300
Closed	00855100002400
Closed	00855100001400
Closed	00855100000400
Closed	31041100301700
Closed	31062100400900
Closed	31043000300900
Closed	00394401802500
Closed	00394401802200
Closed	32052900300700
Closed	00848500000200
Closed	00848500000300
Closed	00394400502400
Closed	00848500001200
Closed	00394406601100
Closed	32053300400300
Closed	30060800201000
Closed	00849800003600
Closed	00849800003700
Closed	00849800003800
Closed	00849800003900

Accessory Dwelling Units

Index # - File Name: 1.0022 - Single Family Dwellings Data\_Snohomish County.pdf

Closed	00849800004000
Closed	00849800003200
Closed	00849800002900
Closed	00849400000200
Closed	30060800101700
Closed	30060800102400
Closed	30060800203000
Closed	30060800202200
Closed	30060800201700
Closed	30060800201600
Closed	30060800203300
Closed	30060800203100
Closed	30060800202600
Closed	30060800202700
Closed	30060800202800
Closed	00850200000600
Closed	00853500005800
Closed	00853500005900
Closed	00853300002800
Closed	00853300002300
Closed	00853300002500
Closed	00853300002600
Closed	00853300001400
Closed	00853300001500
Closed	00853300001600
Closed	00853300001100
Closed	00394403403300
Closed	00852800001600
Closed	00852700006400
Closed	00852700006500
Closed	00852800000100
Closed	00852800000400
Closed	00852800000500
Closed	00852800000700
Closed	00852800000800
Closed	00852700004900
Closed	00852700004000
Closed	00852700003700
Closed	00852700003100
Closed	00852700003300
Closed	00852700003500
Closed	00852700002600
Closed	00852700002700
Closed	00852700002200
Closed	00852700000800
Closed	00852700000900
Closed	30060500400900

Accessory Dwelling Units

Index # - File Name: 1.0022 - Single Family Dwellings Data\_Snohomish County.pdf

Closed	30050900406700
Closed	00860100000100
Closed	30060500302300
Closed	30060500302100
Closed	00394406301100
Closed	30070600100400
Closed	30060200101200
Closed	00851100000100
Closed	00851100000200
Closed	00374100600104
Closed	00850200001300
Closed	00851100001400
Closed	00851100002500
Closed	00851100001800
Closed	27072900401400
Closed	32050500201500
Closed	29062700402100
Closed	28072500201600
Closed	00862400000100
Closed	28071900200400
Closed	00372801200209
Closed	00600200000202
Closed	00862900000100
Closed	00862900000200
Closed	00862900000300
Closed	00862900000500
Closed	00862900000600
Closed	00862900000700
Closed	00862900000800
Closed	00862900000900
Closed	00862900001000
Closed	00862900001100
Closed	00862900001200
Closed	00862900001300
Closed	00862900001400
Closed	00862900001500
Closed	27052400302400
Closed	00863000000200
Closed	00863000000300
Closed	00863000000400
Closed	00863000000500
Closed	00863000000600
Closed	00863000000700
Closed	00863000000800
Closed	00863000000900
Closed	00863000001000
Closed	00863000001100



Accessory Dwelling Units

Index # - File Name: 1.0022 - Single Family Dwellings Data\_Snohomish County.pdf

Closed	00863000001200
Closed	00863000001300
Closed	00863000001400
Closed	00863000001500
Closed	00863000001600
Closed	00863000001700
Closed	00863000001800
Closed	00863000001900
Closed	00863000002000
Closed	00863000002100
Closed	00863000002200
Closed	00863000002300
Closed	00863000002400
Closed	00863000002500
Closed	00863000002600
Closed	00863000002700
Closed	32052100203300
Closed	32052100203400
Closed	32053200205000
Closed	00862600000100
Closed	00862600000200
Closed	00862600000300
Closed	00862600000400
Closed	00862600000500
Closed	00862600000600
Closed	00862600000700
Closed	00862600000800
Closed	00862600000900
Closed	00862600001000
Closed	00862600001100
Closed	00862600001200
Closed	00862600001300
Closed	00862600001400
Closed	30062800401100
Closed	00862500000200
Closed	00862500000300
Closed	32053200205100
Closed	32053200205300
Closed	00373700501103
Closed	00480401503803
Closed	00862300000100
Closed	00862300000300
Closed	00862300000400
Closed	00862300000600
Closed	00862300000700
Closed	00862100001000
Closed	00862100001200

Accessory Dwelling Units

Index # - File Name: 1.0022 - Single Family Dwellings Data\_Snohomish County.pdf

Closed	00862100001200
Closed	00862100001500
Closed	00862100001700
Closed	00862100000400
Closed	00862100000600
Closed	30073100301500
Closed	00372601101414
Closed	00494600300510
Closed	32042900300900
Closed	00862200000100
Closed	00862200000200
Closed	00862200000300
Closed	00862200000400
Closed	00862200000500
Closed	00862200000700
Closed	00862200000800
Closed	00862200000900
Closed	00862200001000
Closed	00862200001200
Closed	00862100000100
Closed	00861700100600
Closed	00861700100700
Closed	00861700200200
Closed	00861700100900
Closed	00861700101000
Closed	00861700101100
Closed	00861700100400
Closed	00861700100100
Closed	00861700100200
Closed	31040500401300
Closed	28061600402200
Closed	00563100000100
Closed	00861100000700
Closed	30061800402000
Closed	29060900401900
Closed	31042300406500
Closed	00861100004500
Closed	00861100004600
Closed	00861100004700
Closed	00861100004800
Closed	00861100004200
Closed	00861100003300
Closed	00861100003500
Closed	00861100003600
Closed	00861100003700
Closed	00861100003800
Closed	00861100003900

Accessory Dwelling Units

Index # - File Name: 1.0022 - Single Family Dwellings Data\_Snohomish County.pdf

Closed	00861100004000
Closed	00861100002900
Closed	00861100003000
Closed	00861100000800
Closed	00861100001100
Closed	00861100001200
Closed	00861100001300
Closed	00861100001500
Closed	00861100001600
Closed	00861100001700
Closed	00861100001800
Closed	00861100002000
Closed	00861100002200
Closed	00861100002300
Closed	00861100002400
Closed	00861100002600
Closed	00861100002700
Closed	32051800201800
Closed	00861100000100
Closed	00861100000200
Closed	00861100000300
Closed	00861100000400
Closed	00861100000500
Closed	30060700201500
Closed	30060700202300
Closed	31053300401200
Closed	00860900001700
Closed	30060200103800
Closed	30060200103900
Closed	00483100001000
Closed	00554300003600
Closed	00543800004403
Closed	00543800004405
Closed	00543800004404
Closed	31043100101800
Closed	32041700403500
Closed	32061700300700
Closed	32061700302100
Closed	30072000200900
Closed	30072000202900
Closed	00552300100501
Closed	00552300100502
Closed	00552300100503
Closed	00556600012900
Closed	32042100101700
Closed	31060900201100
Closed	31060900201300

Accessory Dwelling Units

Index # - File Name: 1.0022 - Single Family Dwellings Data\_Snohomish County.pdf

Closed	30050200102400
Closed	30061400102100
Closed	00858700003200
Closed	31043100200600
Closed	31043100200700
Closed	00858700001300
Closed	00858700001400
Closed	00858700000100
Closed	00858700001700
Closed	00858700002000
Closed	00858700002100
Closed	00858700002200
Closed	00858700002300
Closed	00858700002400
Closed	00858700002500
Closed	00858700002600
Closed	00858700002700
Closed	00858700001000
Closed	00858700001100
Closed	29061000101000
Closed	00373800602006
Closed	00858200000400
Closed	00426800001500
Closed	00858400001500
Closed	00858400001600
Closed	00858400001700
Closed	00511900200402
Closed	00394510901600
Closed	27052700207000
Closed	27090500202300
Closed	00860100000800
Closed	00372801100805
Closed	00372801100806
Closed	00372801100807
Closed	00372801100808
Closed	32052600402600
Closed	00860500002900
Closed	00860500003000
Closed	28072600202600
Closed	29060200200900
Closed	00874300003000
Closed	00860500000200
Closed	00860500000300
Closed	00860500000400
Closed	00860500000500
Closed	00860500000700
Closed	00860500000800

Accessory Dwelling Units

Index # - File Name: 1.0022 - Single Family Dwellings Data\_Snohomish County.pdf

Closed	00860500000900
Closed	00860500001000
Closed	00860500001200
Closed	00860500001400
Closed	00860500001600
Closed	30063600400700
Closed	29062300302400
Closed	29062300302500
Closed	29060900401600
Closed	00551500002500
Closed	00498800102600
Closed	30060300103400
Closed	30063600302100
Closed	30063600302200
Closed	00551500007600
Closed	00551500010200
Closed	00551500010300
Closed	00551500010400
Closed	00551500011300
Closed	00551500012300
Closed	00551500012400
Closed	00551500012500
Closed	27070100100500
Closed	31043500405400
Closed	00865000002200
Closed	00865000002300
Closed	00865000002400
Closed	00865000002500
Closed	00865000002600
Closed	00865000002700
Closed	00865100000800
Closed	00865100000900
Closed	00865100001000
Closed	00865100001100
Closed	27042600400500
Closed	29072800301200
Closed	30060500402500
Closed	00646700000100
Closed	30061100401600
Closed	31041300201000
Closed	00394405300602
Closed	27050300301300
Closed	32052100203500
Closed	32052100203600
Closed	32052100203700
Closed	32052100203800
Closed	00865800000100

Accessory Dwelling Units

Index # - File Name: 1.0022 - Single Family Dwellings Data\_Snohomish County.pdf

Closed	0086580000200
Closed	0086580000400
Closed	0086580000500
Closed	0086580000600
Closed	0086580000800
Closed	0086580001100
Closed	0086580001200
Closed	0086580001300
Closed	0086580001400
Closed	0086580001500
Closed	0086580001700
Closed	0086580001800
Closed	0086580001900
Closed	0086580002000
Closed	0086580002100
Closed	0086580002200
Closed	0086580002300
Closed	0086580002700
Closed	0086580002800
Closed	0086580002900
Closed	0086580003000
Closed	0086580003100
Closed	0086580003200
Closed	0086580003400
Closed	0086580003500
Closed	0086580003600
Closed	0086580001600
Closed	00385600600701
Closed	00385600600702
Closed	28093200301700
Closed	00394401902400
Closed	00866300000100
Closed	00866300000200
Closed	00866300000400
Closed	00866300000500
Closed	00866300000600
Closed	00866300000700
Closed	00866300000800
Closed	00866300000900
Closed	00866300001000
Closed	00866300001100
Closed	29061200301000
Closed	00394406400601
Closed	00742800001200
Closed	00865000000100
Closed	00865000000200
Closed	00865000000300

Accessory Dwelling Units

Index # - File Name: 1.0022 - Single Family Dwellings Data\_Snohomish County.pdf

Closed	0086500000400
Closed	0086500000600
Closed	0086500000900
Closed	0086500001000
Closed	0086500001100
Closed	0086500001300
Closed	0086500001400
Closed	0086500001500
Closed	0086500001600
Closed	0086500001700
Closed	0086500001800
Closed	0086500001900
Closed	0086500002000
Closed	0086500002100
Closed	0086490000100
Closed	0086490000200
Closed	0086490000300
Closed	0086490000500
Closed	0086490000600
Closed	0086490000700
Closed	0086490000800
Closed	0086490000900
Closed	0086490001000
Closed	0086490001200
Closed	0086490001400
Closed	0086490001500
Closed	0086490001600
Closed	0086490001700
Closed	0086490001800
Closed	0086490001900
Closed	0086490002000
Closed	0086490002100
Closed	0086490002200
Closed	0086490002300
Closed	0086490002400
Closed	0086490002500
Closed	0086490002600
Closed	0086490002700
Closed	0086490002800
Closed	0086490002900
Closed	0086490003000
Closed	0086490003100
Closed	0086490003200
Closed	0086490003300
Closed	0086490003400
Closed	0086490003500
Closed	0086490003600

Accessory Dwelling Units

Index # - File Name: 1.0022 - Single Family Dwellings Data\_Snohomish County.pdf

Closed	00864900003700
Closed	00864900003800
Closed	00864900003900
Closed	00864900004000
Closed	00864900004100
Closed	00864900004200
Closed	00864900004300
Closed	00864900004400
Closed	00864900004500
Closed	27051700400400
Closed	32041600401700
Closed	00867000000100
Closed	00867000000200
Closed	00867000000300
Closed	00867000000400
Closed	00867000000500
Closed	00867000000600
Closed	00867000000700
Closed	00867000000800
Closed	00867000000900
Closed	00867000001000
Closed	00867000001100
Closed	00867000001200
Closed	00867000001300
Closed	00867000001400
Closed	00867000001500
Closed	00867000001600
Closed	00867000001700
Closed	00867000001800
Closed	00867000001900
Closed	00867000002000
Closed	00867000002100
Closed	00867000002200
Closed	00867000002400
Closed	00866200000100
Closed	00866200000200
Closed	00866200000400
Closed	00866200000500
Closed	00866200000600
Closed	00866200000700
Closed	00866200000800
Closed	00866200000900
Closed	00866200001000
Closed	30051100100200
Closed	00590700006800
Closed	31060500303100
Closed	00537800001503



Accessory Dwelling Units

Index # - File Name: 1.0022 - Single Family Dwellings Data\_Snohomish County.pdf

Closed	00537800001504
Closed	00537800001505
Closed	00537800001506
Closed	00867000006000
Closed	00867000006200
Closed	00867000006300
Closed	27060300201200
Closed	00563100000104
Closed	00563100000200
Closed	30071900103800
Closed	27052100405500
Closed	00627300000500
Closed	31043000201300
Closed	28073400102500
Closed	00414400201100
Closed	00866900000100
Closed	00866900000200
Closed	00866900000900
Closed	00866900001500
Closed	00960003901200
Closed	00494600202205
Closed	30073000400700
Closed	00452600102100
Closed	00417900001500
Closed	00867600000100
Closed	00867600000200
Closed	00867600000300
Closed	00867600000400
Closed	00867600000600
Closed	00867600000700
Closed	00867600001100
Closed	00867600002100
Closed	00867600002200
Closed	00867600002300
Closed	00867600002400
Closed	00867600002500
Closed	00551400000200
Closed	00557300203600
Closed	29071500300600
Closed	00863200000100
Closed	31062000400700
Closed	00863200000400
Closed	00483100001100
Closed	31043200201200
Closed	00863400000100
Closed	00863400000200
Closed	00863400000300

Accessory Dwelling Units

Index # - File Name: 1.0022 - Single Family Dwellings Data\_Snohomish County.pdf

Closed	0086340000400
Closed	0086340000500
Closed	0086340000600
Closed	00863400001300
Closed	00863400001400
Closed	00863400001500
Closed	00863400001600
Closed	00863400001700
Closed	00863400001800
Closed	00863400001900
Closed	00863400002000
Closed	00863400002200
Closed	00863400002300
Closed	00863400002400
Closed	00863400002500
Closed	00863400002600
Closed	00863400002700
Closed	32041700201200
Closed	27070500205600
Closed	00419500001403
Closed	30052200211500
Closed	31062900202900
Closed	31062900203000
Closed	31062900203100
Closed	31062900203200
Closed	30050200102200
Closed	00864000004100
Closed	00864000004200
Closed	00864000004300
Closed	00864000004400
Closed	32071000200100
Closed	28083000402200
Closed	28073000405100
Closed	28073000405200
Closed	31043000300800
Closed	00590700016304
Closed	00863500000100
Closed	00863500000200
Closed	00863500000300
Closed	00863500000400
Closed	00863500000500
Closed	00863500000600
Closed	00863500000700
Closed	00863500000800
Closed	00863500000900
Closed	00863500001000
Closed	00863500001100

Accessory Dwelling Units

Index # - File Name: 1.0022 - Single Family Dwellings Data\_Snohomish County.pdf

Closed	00863500001200
Closed	00863500001300
Closed	00863500001400
Closed	00863500001500
Closed	00863600000100
Closed	00863600000200
Closed	00863600000300
Closed	00863600000400
Closed	00863600000500
Closed	00863600000600
Closed	00863600001400
Closed	00863600001500
Closed	00863600001600
Closed	00863600001700
Closed	00863600001800
Closed	00863600001900
Closed	00863600002000
Closed	00863600002100
Closed	00863600002200
Closed	00863600002300
Closed	00863600002400
Closed	00863600002500
Closed	00863600002600
Closed	00863600002700
Closed	00863600002800
Closed	00863600002900
Closed	00863600003000
Closed	00863600003100
Closed	00863600003200
Closed	00863600003300
Closed	00863600003400
Closed	00863600003500
Closed	00863600003600
Closed	00863600003700
Closed	00863600003800
Closed	00863600003900
Closed	00863600004000
Closed	00863600004100
Closed	00863600004200
Closed	00863600004300
Closed	00863600004400
Closed	00863600004500
Closed	00863600004600
Closed	00863600004700
Closed	00863600004800
Closed	00863600004900
Closed	00863600005000

Accessory Dwelling Units

Index # - File Name: 1.0022 - Single Family Dwellings Data\_Snohomish County.pdf

Closed	00863600005100
Closed	00863600005200
Closed	00863600005300
Closed	00863600005400
Closed	00863600005500
Closed	00863600005600
Closed	00863600005700
Closed	00863600005800
Closed	00863600005900
Closed	00863600006000
Closed	00863600006100
Closed	00863600006200
Closed	00863600006300
Closed	00863600006400
Closed	00863600006500
Closed	00863600006600
Closed	00863600006700
Closed	00863600006800
Closed	00863600006900
Closed	00863600007000
Closed	00863600007100
Closed	00863600007200
Closed	00863600007300
Closed	00863600007400
Closed	00863600007500
Closed	00863600007600
Closed	00863600007700
Closed	00863600007800
Closed	00863600007900
Closed	00863600008000
Closed	00863600008100
Closed	00863600008200
Closed	00863600008300
Closed	00863600008400
Closed	30050300101900
Closed	00863800000100
Closed	00863800000200
Closed	00863800000300
Closed	00863800000400
Closed	00863800000500
Closed	00863800000600
Closed	00863800000700
Closed	00863800000800
Closed	00863800000900
Closed	00863800001000
Closed	00863800001100
Closed	00863800001200

Accessory Dwelling Units

Index # - File Name: 1.0022 - Single Family Dwellings Data\_Snohomish County.pdf

Closed	00863800001300
Closed	00863800001400
Closed	00863800001500
Closed	00863800001600
Closed	00863800001700
Closed	00863800001800
Closed	00863800001900
Closed	00863800002000
Closed	00863800002100
Closed	00863800002200
Closed	00863800002300
Closed	00863800002400
Closed	00863800002500
Closed	00863800002600
Closed	00863800002700
Closed	00863800002800
Closed	00863800002900
Closed	00863800003000
Closed	00863800003100
Closed	00863800003200
Closed	00863800003300
Closed	00863800003400
Closed	30070100400200
Closed	00492800001800
Closed	30060200303600
Closed	00591200100204
Closed	31052000304500
Closed	27051400306300
Closed	30052100108400
Closed	30052100110400
Closed	29062200301000
Closed	28060500201300
Closed	32063300302300
Closed	00471400004400
Closed	00864000000700
Closed	00864000000800
Closed	00864000000900
Closed	00864000001000
Closed	00864000001100
Closed	00864000001200
Closed	00864000001300
Closed	00864000001400
Closed	00864000001500
Closed	00864000001600
Closed	00864000001700
Closed	00864000001800
Closed	00864000001900

Accessory Dwelling Units

Index # - File Name: 1.0022 - Single Family Dwellings Data\_Snohomish County.pdf

Closed	00864000002000
Closed	00864000002100
Closed	00864000003000
Closed	00864000003100
Closed	00864000003200
Closed	00864000003300
Closed	00864000003400
Closed	00864000003500
Closed	00864000003800
Closed	00864000003900
Closed	00864000004000
Closed	00864000004500
Closed	00864000004600
Closed	00864000004700
Closed	00864000004800
Closed	00864000004900
Closed	00864000005000
Closed	00864000005100
Closed	00864000005200
Closed	00864000005300
Closed	00864000005400
Closed	00863900000100
Closed	00863900000200
Closed	00863900000300
Closed	00863900000400
Closed	27060900401100
Closed	29062000300400
Closed	32041600100900
Closed	29072200200700
Closed	31052400102100
Closed	00513800009512
Closed	00513800009513
Closed	00513800009514
Closed	00960007002600
Closed	31043100101900
Closed	31042300101300
Closed	00864500000100
Closed	00864500000200
Closed	00864500000300
Closed	00864500000400
Closed	00864500000500
Closed	00864500000600
Closed	00864500000700
Closed	00864500000800
Closed	00864500000900
Closed	00864500001000
Closed	00864500001100

Accessory Dwelling Units

Index # - File Name: 1.0022 - Single Family Dwellings Data\_Snohomish County.pdf

Closed	00864500001200
Closed	00864500001300
Closed	00864500001400
Closed	00864500001500
Closed	00864500001600
Closed	00864500001700
Closed	00864500001800
Closed	00864500001900
Closed	00864500002000
Closed	00864500002100
Closed	00864500002200
Closed	00864500002300
Closed	00864500002400
Closed	00864500002500
Closed	00864500002600
Closed	00864500002700
Closed	00551400001400
Closed	32091800200700
Closed	00385200001600
Closed	00471400003300
Closed	00401000003500
Closed	00835200000700
Closed	32041800201300
Closed	27053500102500
Closed	00414400201401
Closed	00832300001700
Closed	00394509100202
Closed	00836800000600
Closed	00836800000800
Closed	27081800400300
Closed	31063100202100
Closed	00604800001202
Closed	00837100004100
Closed	00837100004200
Closed	00837100004300
Closed	00837100004400
Closed	00837100004500
Closed	00837100004600
Closed	00837100004700
Closed	00837100004800
Closed	00837100003000
Closed	00837100003100
Closed	00837100003200
Closed	00837100003300
Closed	00837100003400
Closed	00837100003500
Closed	00837100003600

Accessory Dwelling Units

Index # - File Name: 1.0022 - Single Family Dwellings Data\_Snohomish County.pdf

Closed	00837100003700
Closed	00837100003800
Closed	00837100003900
Closed	00837100004000
Closed	00837100002500
Closed	00837100002600
Closed	00837100002700
Closed	00837100002800
Closed	00836800001400
Closed	00590700006900
Closed	00489100007800
Closed	00837600002900
Closed	00837600003100
Closed	00837600003200
Closed	00837600003300
Closed	00837600001400
Closed	00837600001600
Closed	00837600001700
Closed	00837600001800
Closed	00837600001900
Closed	00837600002000
Closed	00837600002100
Closed	00837600002300
Closed	00837600002400
Closed	00837600002500
Closed	00837600002600
Closed	00837600002700
Closed	00600700001000
Closed	32053300400900
Closed	00832300001100
Closed	00832300001300
Closed	00832300002000
Closed	00490400000200
Closed	00831200004800
Closed	28060500400200
Closed	00831300001000
Closed	00831300001500
Closed	00466100005500
Closed	32080700101500
Closed	00556600012000
Closed	00831200003300
Closed	00831200003400
Closed	00831200003500
Closed	00831200003600
Closed	00831200003700
Closed	00831200003800
Closed	00831200003900



Accessory Dwelling Units

Index # - File Name: 1.0022 - Single Family Dwellings Data\_Snohomish County.pdf

Closed	00831200004000
Closed	00831200004100
Closed	00831200004200
Closed	00831200004300
Closed	00831200004400
Closed	00831200003100
Closed	00830700000500
Closed	00830700000700
Closed	00830700000100
Closed	00828800003700
Closed	00828800003800
Closed	00828800003900
Closed	00828800004200
Closed	00828800003400
Closed	00828800003500
Closed	00590700009100
Closed	00828800004500
Closed	00828800004600
Closed	00828800004700
Closed	00828800004900
Closed	00828800005000
Closed	00828800005100
Closed	00828800005200
Closed	00828800005300
Closed	00828800005400
Closed	29063300301900
Closed	28053600402900
Closed	30073000202000
Closed	00823400007100
Closed	00372801000902
Closed	27071100401200
Closed	30050200300200
Closed	31062000202700
Closed	00403900024005
Closed	00817000000700
Closed	32042500300200
Closed	00823300001500
Closed	00823300001600
Closed	00823300001900
Closed	00823300002000
Closed	31060400101000
Closed	31062900102200
Closed	32051200101500
Closed	32062000201700
Closed	30060200101400
Closed	31062900200400
Closed	00818500000800

Accessory Dwelling Units

Index # - File Name: 1.0022 - Single Family Dwellings Data\_Snohomish County.pdf

Closed	00821200000700
Closed	32041800401300
Closed	00823300003900
Closed	00823300004000
Closed	00823300003300
Closed	00823300003400
Closed	00823300003500
Closed	00823300002400
Closed	00823300002600
Closed	00823300002800
Closed	00823300004500
Closed	00823300004600
Closed	00823300004700
Closed	00823300004800
Closed	00823300004900
Closed	00823300005000
Closed	00823300005100
Closed	00823300005600
Closed	00823300005700
Closed	00823300005800
Closed	00823300004200
Closed	00823300004300
Closed	00823300006000
Closed	00823300007300
Closed	00823300007400
Closed	00823300007500
Closed	00823300007800
Closed	00823300007900
Closed	00823300008100
Closed	00823300008300
Closed	00823300006900
Closed	00823300006200
Closed	00823300006300
Closed	00823300006400
Closed	00823300006500
Closed	00823300008500
Closed	00823300014100
Closed	00823300010100
Closed	00823300013600
Closed	00538000010802
Closed	30073100301200
Closed	00823300013900
Closed	00823400007600
Closed	00823400007700
Closed	00823400008000
Closed	00823400006900
Closed	00823400005200

Accessory Dwelling Units

Index # - File Name: 1.0022 - Single Family Dwellings Data\_Snohomish County.pdf

Closed	00823400006700
Closed	00403900018408
Closed	30040300301600
Closed	00823400004600
Closed	00394509400200
Closed	30071900400500
Closed	32050700401900
Closed	00808500000600
Closed	29061700306300
Closed	27043600301400
Closed	00493900009804
Closed	32071100400200
Closed	32040800101200
Closed	29061100202500
Closed	30041400402900
Closed	32040300301900
Closed	00629600007000
Closed	32063200403300
Closed	32063300200900
Closed	00498700000100
Closed	00589600009800
Closed	00589600003200
Closed	00589600003300
Closed	00837600007400
Closed	00837600007700
Closed	00837600007800
Closed	00837600007900
Closed	00837600004100
Closed	00837600004200
Closed	00837600004300
Closed	00837600004500
Closed	00837600004600
Closed	00837600004800
Closed	00837600005000
Closed	00837600005100
Closed	00837600005200
Closed	00837600008400
Closed	00836500001500
Closed	00836500006800
Closed	00836500006900
Closed	00836500005600
Closed	00836500005000
Closed	00836500005100
Closed	00836500005300
Closed	00836500005400
Closed	00836500003100
Closed	00836500003200

Accessory Dwelling Units

Index # - File Name: 1.0022 - Single Family Dwellings Data\_Snohomish County.pdf

Closed	00836500002200
Closed	00836500004100
Closed	00836500003600
Closed	00836500002700
Closed	00838200000600
Closed	00838800001200
Closed	00838800001300
Closed	00838800001400
Closed	00796600012300
Closed	00796600012400
Closed	31060700101300
Closed	00838800002200
Closed	00838800006100
Closed	00838800007000
Closed	00838800009200
Closed	00836500006100
Closed	30060800103500
Closed	32061500201100
Closed	28081900201100
Closed	27070400400600
Closed	29051200404300
Closed	29051200405000
Closed	30063200401300
Closed	29062300302000
Closed	00839100000300
Closed	31061900201400
Closed	00839100000100
Closed	00839200001200
Closed	00839200001500
Closed	00839200001800
Closed	00796600018200
Closed	00796600018300
Closed	00796600018400
Closed	00796600018500
Closed	31060500303200
Closed	00509300000503
Closed	00600300502400
Closed	32040900401000
Closed	00796600018800
Closed	29063600100800
Closed	00796600023000
Closed	00796600020900
Closed	00840300000600
Closed	00840300000700
Closed	00796600023900
Closed	00796600024000
Closed	00796600024100

Accessory Dwelling Units

Index # - File Name: 1.0022 - Single Family Dwellings Data\_Snohomish County.pdf

Closed	00796600024200
Closed	00796600024500
Closed	00841700003000
Closed	00841700003100
Closed	00422500006200
Closed	00841700001500
Closed	00841700000100
Closed	00841700004000
Closed	00841700004100
Closed	00841700003800
Closed	00841700001700
Closed	00841700003500
Closed	30061800301200
Closed	00841900000900
Closed	00494600100103
Closed	28071600104000
Closed	00509300000902
Closed	00842600000100
Closed	00842600000500
Closed	00842800009100
Closed	00842800009200
Closed	00842800009300
Closed	00842800009400
Closed	00842800009500
Closed	00842800009600
Closed	00842800009700
Closed	00842800009800
Closed	00842800009900
Closed	00842800010000
Closed	00842800010100
Closed	00842800010200
Closed	00842800010300
Closed	00842800010400
Closed	00842800010500
Closed	00842800010600
Closed	00842800010700
Closed	00842800010800
Closed	00842800010900
Closed	00842800011000
Closed	00842800011100
Closed	00842800011200
Closed	00842800011300
Closed	00842800011400
Closed	00842800011500
Closed	00842800011600
Closed	00842800011700
Closed	00842800011800

Accessory Dwelling Units

Index # - File Name: 1.0022 - Single Family Dwellings Data\_Snohomish County.pdf

Closed	00842800011900
Closed	00842800012000
Closed	00842800012100
Closed	00842800012200
Closed	00842800012300
Closed	00842800012400
Closed	00842800012500
Closed	00842800012600
Closed	00842800012700
Closed	00842800012800
Closed	00842800012900
Closed	00842800013000
Closed	00842800013100
Closed	00842800013200
Closed	00842800013300
Closed	00842800013400
Closed	00842800013500
Closed	00842800013600
Closed	00842800013700
Closed	00842800013800
Closed	00842800013900
Closed	00842800014000
Closed	00842800014100
Closed	00842800014200
Closed	00842800014300
Closed	00842800014400
Closed	00842800014500
Closed	00842800014600
Closed	00842800014700
Closed	00842800014800
Closed	00842800015900
Closed	00842800016000
Closed	00842800016100
Closed	00842800016200
Closed	00842800016300
Closed	00842800016400
Closed	00842800016500
Closed	00842800016600
Closed	00842800016700
Closed	00842800016800
Closed	00842800016900
Closed	00842800017000
Closed	00842800017100
Closed	00842800017200
Closed	00842800017300
Closed	00842800017400
Closed	00842800017500

Accessory Dwelling Units

Index # - File Name: 1.0022 - Single Family Dwellings Data\_Snohomish County.pdf

Closed	00842800017600
Closed	00842800017700
Closed	00842800017800
Closed	00842800017900
Closed	00842800018000
Closed	00842800008300
Closed	00842800008400
Closed	00842800008500
Closed	00842800008600
Closed	00842800002100
Closed	00842800002200
Closed	00842800002300
Closed	00842800002400
Closed	00842800002500
Closed	00842800002600
Closed	00842800002700
Closed	00842800002800
Closed	00960003903600
Closed	30063200202300
Closed	00844100002400
Closed	00844100002500
Closed	00844100002600
Closed	00844100000600
Closed	00844100000800
Closed	00844100002800
Closed	00844100002900
Closed	29060100202200
Closed	29070700300100
Closed	00385600500103
Closed	00844300000700
Closed	31050600101700
Closed	31050600101800
Closed	31050600101900
Closed	27061800104000
Closed	00467100010100
Closed	30060600100600
Closed	30060600102500
Closed	31063300201400
Closed	32100800301800
Closed	31061800401800
Closed	30062400301200
Closed	30062300401200
Closed	30062300401300
Closed	00846200003600
Closed	32042300302300
Closed	00846800000200
Closed	00865100000200

Accessory Dwelling Units

Index # - File Name: 1.0022 - Single Family Dwellings Data\_Snohomish County.pdf

Closed	00865100000300
Closed	00865100000400
Closed	00865100000500
Closed	00865100000600
Closed	00865100000700
Closed	00481900000600
Closed	28071500300400
Closed	28071500300600
Closed	28071500301300
Closed	00847800001000
Closed	29062300100500
Closed	00847800000300
Closed	00848200004400
Closed	00394400405300
Closed	00394400403700
Closed	00394400403100
Closed	00848500001000
Closed	00848400001000
Closed	00848400001100
Closed	00848400001200
Closed	00848400001300
Closed	00848400001400
Closed	00848400001500
Closed	00848400001600
Closed	00848400001700
Closed	00489700101302
Closed	00494511401600
Closed	00494511501401
Closed	00609700000100
Closed	00609700002900
Closed	00494600301101
Closed	32050400201100
Closed	32040400101600
Closed	32060300301300
Closed	00621500006100
Closed	32100400200500
Closed	32040500401900
Closed	32100600401000
Closed	32100700200100
Closed	32060800300900
Closed	32090800300500
Closed	32040900301100
Closed	32091300201700
Closed	32051200300400
Closed	32051200300600
Closed	32061200200600
Closed	32061000401400



Accessory Dwelling Units

Index # - File Name: 1.0022 - Single Family Dwellings Data\_Snohomish County.pdf

Closed	32061700201400
Closed	32041400202200
Closed	32051900301000
Closed	32051900201600
Closed	32051900401100
Closed	32062000201500
Closed	32052000102000
Closed	32052000102000
Closed	32042600401600
Closed	32062100101200
Closed	32052200201800
Closed	32042300301000
Closed	32042300402100
Closed	32053000400700
Closed	32052700401700
Closed	32052700402600
Closed	32063200201100
Closed	32053200302800
Closed	00394406601400
Closed	00394406700500
Closed	00394406400105
Closed	00394406400100
Closed	00394406200100
Closed	00394403200907
Closed	00480700002201
Closed	00394510401300
Closed	00445100001300
Closed	00406300005700
Closed	31052600402100
Closed	31052600300500
Closed	31052600303400
Closed	31063100302400
Closed	31063100302500
Closed	31043400100400
Closed	31040200100400
Closed	31050400301100
Closed	31040700402300
Closed	31061700203600
Closed	31041400200100
Closed	31041400201000
Closed	31051900201000
Closed	31061800400900
Closed	31051900102800
Closed	31042200306400
Closed	31052100305600
Closed	31052400100700
Closed	31052400202400

Accessory Dwelling Units

Index # - File Name: 1.0022 - Single Family Dwellings Data\_Snohomish County.pdf

Closed	31042300301700
Closed	31042600401200
Closed	31052500401200
Closed	31042500100100
Closed	30073000300100
Closed	30052900103300
Closed	30073000401000
Closed	30063600102000
Closed	00401000006300
Closed	00385300009800
Closed	00394300000800
Closed	00400800001600
Closed	00405200002000
Closed	00406400001000
Closed	00480000009600
Closed	00475500000500
Closed	00470600005400
Closed	00489000001600
Closed	00489100005800
Closed	00495900002100
Closed	00543300003900
Closed	31062900301100
Closed	00520200005500
Closed	00543400000100
Closed	00543900001100
Closed	00548200002100
Closed	00828700000500
Closed	00828700000800
Closed	00551500008500
Closed	00551500008600
Closed	00551500007300
Closed	00551500007400
Closed	00551500007500
Closed	00551500007700
Closed	00551500007800
Closed	00551500004700
Closed	00551500004800
Closed	00551500001300
Closed	00551500001400
Closed	00551500001600
Closed	00551500003100
Closed	00551500003200
Closed	00551500003900
Closed	00551500004300
Closed	00551400002700
Closed	00551400004900
Closed	00551400008900

Accessory Dwelling Units

Index # - File Name: 1.0022 - Single Family Dwellings Data\_Snohomish County.pdf

Closed	00551400009000
Closed	00551400009100
Closed	00551400009200
Closed	00551400006000
Closed	00551500000900
Closed	00551500001000
Closed	00551500009800
Closed	00551500008900
Closed	00551500011500
Closed	00551500009500
Closed	00556800200602
Closed	00557200200300
Closed	00600600000100
Closed	00600600000200
Closed	00590700018600
Closed	00600200000201
Closed	00590600000100
Closed	00557300203700
Closed	00557300203800
Closed	00557300203900
Closed	00557300204000
Closed	00557300204100
Closed	00557600002802
Closed	00560400003500
Closed	00582600701200
Closed	00604500000502
Closed	00628400000600
Closed	00628400001700
Closed	00681500001800
Closed	00604900001201
Closed	30040200300600
Closed	30050100202500
Closed	00795700001000
Closed	00548000301704
Closed	00533400002000
Closed	00590700024704
Closed	00597600000204
Closed	00393800001300
Closed	00442000001000
Closed	00491900500401
Closed	00516700002800
Closed	00516700002900
Closed	00493600000300
Closed	00493700002301
Closed	30050500302400
Closed	30060300103600
Closed	30060700100300

Accessory Dwelling Units

Index # - File Name: 1.0022 - Single Family Dwellings Data\_Snohomish County.pdf

Closed	30060200102700
Closed	30041400401300
Closed	30051200200200
Closed	30041300401700
Closed	30060800400800
Closed	30070700302300
Closed	30051200102800
Closed	00828500002700
Closed	00828500002300
Closed	30061400303400
Closed	30061500200600
Closed	30071900104100
Closed	30062300202700
Closed	30052400401500
Closed	30042500300400
Closed	30052500201900
Closed	29062000210300
Closed	29061500401100
Closed	29061700302300
Closed	29062100302300
Closed	29063500101000
Closed	29062700201000
Closed	29062600201200
Closed	29062800101000
Closed	29062900101800
Closed	29061100400700
Closed	29051100200900
Closed	29060600301500
Closed	29060300202400
Closed	00789500000400
Closed	29050200206400
Closed	00789500002300
Closed	00789500002400
Closed	00795800000200
Closed	00769300003500
Closed	00803800001000
Closed	00795800001200
Closed	00663500000400
Closed	00663500001300
Closed	00613900003400
Closed	00614700203200
Closed	00592100000900
Closed	00592100001100
Closed	00597400000910
Closed	00574100004500
Closed	00573700001100
Closed	00573800006600

Accessory Dwelling Units

Index # - File Name: 1.0022 - Single Family Dwellings Data\_Snohomish County.pdf

Closed	00574100013200
Closed	00574200005900
Closed	00560000004700
Closed	00568800101003
Closed	00426800000300
Closed	00432100002100
Closed	00396000002100
Closed	00399200002100
Closed	00802400005000
Closed	00802400003400
Closed	00802400006700
Closed	00802400007600
Closed	00802400007700
Closed	00802400007800
Closed	00802400007900
Closed	00793000002200
Closed	00802400002700
Closed	00658300002000
Closed	00715300000100
Closed	28060400303100
Closed	28060400101200
Closed	28060300405100
Closed	28050200100600
Closed	28060200400300
Closed	28060200400300
Closed	28070800201000
Closed	28060900103800
Closed	28051200203900
Closed	28061200200100
Closed	28041300303200
Closed	28061400201100
Closed	28071200300800
Closed	28071500400600
Closed	28071600100600
Closed	28072100101500
Closed	28062200101400
Closed	28072800200500
Closed	28053100203100
Closed	28073000200300
Closed	28082900102200
Closed	28052900400900
Closed	28072900100800
Closed	28073200200900
Closed	28073200201400
Closed	28083100300400
Closed	28073400401900
Closed	00384200000400

Accessory Dwelling Units

Index # - File Name: 1.0022 - Single Family Dwellings Data\_Snohomish County.pdf

Closed	00384200000600
Closed	28053600103300
Closed	28063600101900
Closed	28073600301600
Closed	00373300200402
Closed	00512000210800
Closed	00512000100300
Closed	00512000100600
Closed	00511900300701
Closed	00500900003100
Closed	00500100002804
Closed	00479000201100
Closed	00509300000901
Closed	00556600008000
Closed	00577600201200
Closed	00582900000300
Closed	00609600001600
Closed	00614200000600
Closed	00623700006800
Closed	00624600001700
Closed	00637600001000
Closed	00646700000600
Closed	00634100000500
Closed	00633400000700
Closed	00460100003500
Closed	00460000006000
Closed	00460200014800
Closed	00460200020200
Closed	00464100000200
Closed	00433100002700
Closed	00433100005000
Closed	00430400001600
Closed	00428200001900
Closed	00427100001100
Closed	00403900016802
Closed	00403900023906
Closed	00403900024701
Closed	00403900024701
Closed	00403900024703
Closed	00413400000600
Closed	00373101001003
Closed	27062600302900
Closed	27052700400400
Closed	27052200303500
Closed	27062100301600
Closed	27052300201500
Closed	27052400202800

Accessory Dwelling Units

Index # - File Name: 1.0022 - Single Family Dwellings Data\_Snohomish County.pdf

Closed	00794600000400
Closed	00794600001800
Closed	27062700301200
Closed	27062700402900
Closed	27062900404100
Closed	27053500201600
Closed	27063300301400
Closed	27043100203800
Closed	27063200301100
Closed	27073000400900
Closed	00372801101205
Closed	00373000401403
Closed	00373002303204
Closed	27050300300600
Closed	27070100300500
Closed	27050200301900
Closed	27070300202600
Closed	27090800101500
Closed	27090900301600
Closed	27071100400700
Closed	27071100301500
Closed	27051100106000
Closed	27071000401000
Closed	27051400201300
Closed	27051400207000
Closed	27051500205000
Closed	27051300200200
Closed	27061200400100
Closed	27061600302100
Closed	27061700302200
Closed	27052100207700
Closed	27052100106800
Closed	27071800201600
Closed	27081800202000
Closed	00543300006600
Closed	29062100201900
Closed	00513700004812
Closed	32052900403900
Closed	32052900403600
Closed	00556800101802
Closed	00512200000200
Closed	32063300304000
Closed	30060700202800
Closed	00394406400102
Closed	00394406400302
Closed	32070700402400
Closed	28042400409300

Accessory Dwelling Units

Index # - File Name: 1.0022 - Single Family Dwellings Data\_Snohomish County.pdf

Closed	28042400409400
Closed	28042400409500
Closed	28042400409600
Closed	31060700301700
Closed	28070600303000
Closed	28041300207500
Closed	28062400302500
Closed	30042400201400
Closed	28071500301000
Closed	00633300000100
Closed	00394510900200
Closed	00394510900300
Closed	00394510900400
Closed	00761500099800
Closed	30062100202200
Closed	29062300302700
Closed	29062300302600
Closed	28062400303400
Closed	31053300401200
Closed	31053300401200
Closed	00870000000200
Closed	00556800301400
Closed	30051500306700
Closed	30051500306800
Closed	30051500306900
Closed	00373002701204
Closed	00870000000400
Closed	00870000000500
Closed	00870000001400
Closed	00870000001800
Closed	00870000001900
Closed	00870000002000
Closed	00870000002100
Closed	00870000002500
Closed	00870000002600
Closed	00870000002300
Closed	00870000002900
Closed	00870000003000
Closed	00870000003500
Closed	00870000003600
Closed	00870000003700
Closed	00870000003800
Closed	00870000003900
Closed	00870000004000
Closed	00870000004600
Closed	00870000004700
Closed	00870000004800



Accessory Dwelling Units

Index # - File Name: 1.0022 - Single Family Dwellings Data\_Snohomish County.pdf

Closed	0087000004900
Closed	0087000005000
Closed	0087000005100
Closed	0087000005200
Closed	0087000005300
Closed	0087000003200
Closed	0087000003300
Closed	0087000003400
Closed	27051600102800
Closed	27052600104600
Closed	00870100100200
Closed	00870100100300
Closed	00511900300801
Closed	00870100100800
Closed	00870100100900
Closed	00870100101300
Closed	00870100101400
Closed	00870100101500
Closed	00870100102200
Closed	00870100102300
Closed	00870100102400
Closed	00870100200600
Closed	00490200000200
Closed	27070500205500
Closed	27062700402100
Closed	31050300200600
Closed	00869900000300
Closed	00869900000500
Closed	00869900000700
Closed	00869900000800
Closed	00869900001000
Closed	00869900001100
Closed	00869900001800
Closed	00869900001900
Closed	30061000300500
Closed	31053300401200
Closed	00394406400802
Closed	29061400400900
Closed	31053300401200
Closed	00537800005601
Closed	31043100102500
Closed	31050400302800
Closed	00480401803101
Closed	00870300000300
Closed	00870300000400
Closed	00870300000500
Closed	00870300000600

Accessory Dwelling Units

Index # - File Name: 1.0022 - Single Family Dwellings Data\_Snohomish County.pdf

Closed	00870300000700
Closed	00870300000800
Closed	00870300000900
Closed	00870300001000
Closed	00870300001100
Closed	00870300001200
Closed	00870300001300
Closed	00870300001400
Closed	00870300001500
Closed	00870300001900
Closed	00870300002000
Closed	00870300002100
Closed	00870300002700
Closed	00870300002800
Closed	00870300002900
Closed	00870300003000
Closed	00870300003300
Closed	00870300003400
Closed	00867600004400
Closed	00867600004500
Closed	00867600004600
Closed	00867600004700
Closed	00867600004800
Closed	00867600004900
Closed	00867600005000
Closed	00867600005100
Closed	00867600005200
Closed	00867600005300
Closed	00867600005400
Closed	00867600005500
Closed	00867600005600
Closed	00867600005700
Closed	00867600005800
Closed	00867600006100
Closed	00867600006200
Closed	00867600006300
Closed	00867600006400
Closed	00867600006500
Closed	00867600006600
Closed	00867600006700
Closed	00867600006800
Closed	00867600006900
Closed	00867600007000
Closed	00867600007100
Closed	00867600007200
Closed	00867600007300
Closed	00867600007400

Accessory Dwelling Units

Index # - File Name: 1.0022 - Single Family Dwellings Data\_Snohomish County.pdf

Closed	00867600007500
Closed	00867600007600
Closed	00867600007700
Closed	00867600007800
Closed	00867600007900
Closed	00867600008000
Closed	00867600008100
Closed	00867600008200
Closed	00867600008300
Closed	00867600003500
Closed	00867600003600
Closed	00867600003700
Closed	00867600003800
Closed	00867600003900
Closed	00867600004000
Closed	00867600004100
Closed	00867600001600
Closed	00867600001700
Closed	00867600001800
Closed	00867600001900
Closed	00867600008500
Closed	28050200401700
Closed	28050200403100
Closed	32052900402100
Closed	32052900403500
Closed	00866700000100
Closed	00866700000300
Closed	00866700000500
Closed	00866700000700
Closed	00511900100402
Closed	00866700004700
Closed	00866700006000
Closed	00866700009700
Closed	00866700014000
Closed	00866800019400
Closed	00866800019600
Closed	00866800019800
Closed	00867600009000
Closed	00960003901600
Closed	00866800022500
Closed	00866800022700
Closed	00866800022900
Closed	00866800023100
Closed	00866800023300
Closed	00866800023500
Closed	00866800023700
Closed	00866800023800

Accessory Dwelling Units

Index # - File Name: 1.0022 - Single Family Dwellings Data\_Snohomish County.pdf

Closed	00866800023900
Closed	00866800024100
Closed	00866800024300
Closed	00866800021900
Closed	00866800022100
Closed	28072900405200
Closed	00409500000601
Closed	00868000000200
Closed	00868000000400
Closed	00868000000500
Closed	00868000001100
Closed	00868000001200
Closed	00868000002100
Closed	00868000002200
Closed	00868000000900
Closed	00868000001600
Closed	00868000001700
Closed	00868000003100
Closed	00868000003200
Closed	00868000003300
Closed	00512000208400
Closed	32100400201500
Closed	28081900201900
Closed	29060400102100
Closed	00498800301600
Closed	29052600103400
Closed	27051400401200
Closed	32051800201300
Closed	00868300100100
Closed	00868300100200
Closed	00868300100300
Closed	00868300100400
Closed	00868300100500
Closed	00868300100600
Closed	00868300100700
Closed	00868300100800
Closed	00868300100900
Closed	00868300101000
Closed	00868300101100
Closed	00868300101200
Closed	00868300101300
Closed	00868300101400
Closed	00868300101500
Closed	00868300101600
Closed	00868300101700
Closed	00868300101800
Closed	00868000001900

Accessory Dwelling Units

Index # - File Name: 1.0022 - Single Family Dwellings Data\_Snohomish County.pdf

Closed	00394406000104
Closed	28072800201300
Closed	00868300102000
Closed	00868300102100
Closed	00868300102200
Closed	00868300102400
Closed	00868300102500
Closed	00868300102600
Closed	00868300102700
Closed	00868300102800
Closed	00868300103100
Closed	00868400000500
Closed	00868400000200
Closed	00868300200200
Closed	00868300200400
Closed	00868300200600
Closed	00868300200900
Closed	00868300201100
Closed	00868300201400
Closed	00868300201500
Closed	00868300201600
Closed	00868300201800
Closed	00868300201900
Closed	00868300202000
Closed	00868300202100
Closed	00868300202200
Closed	00868300202300
Closed	00868300202400
Closed	00868300202500
Closed	00868300202600
Closed	00868300202700
Closed	29062400401200
Closed	00535300000400
Closed	31063000101400
Closed	00385500401100
Closed	00423700001300
Closed	00403800014405
Closed	29061100401900
Closed	00568800101002
Closed	00868900000400
Closed	00868900000500
Closed	00868900000600
Closed	00868900000700
Closed	00868900000800
Closed	00868900000900
Closed	00868900001000
Closed	00868900001100

Accessory Dwelling Units

Index # - File Name: 1.0022 - Single Family Dwellings Data\_Snohomish County.pdf

Closed	00868900001200
Closed	00868900001300
Closed	00868900001400
Closed	00868900001500
Closed	00868900001600
Closed	00868900001700
Closed	00868900001800
Closed	00868900001900
Closed	00868900002000
Closed	00868900002100
Closed	00868900002200
Closed	00868900002300
Closed	00868900002400
Closed	28081900201400
Closed	28073300406700
Closed	00598100005000
Closed	28060800100900
Closed	28050100101600
Closed	00509500004401
Closed	00509500004402
Closed	00509500004403
Closed	00509500004304
Closed	00481900000300
Closed	00403800301400
Closed	29072600400400
Closed	31040200101000
Closed	27050300303600
Closed	00960003903100
Closed	00960003901400
Closed	31053300401200
Closed	00590700029802
Closed	00590700029803
Closed	00590700029804
Closed	31040500400100
Closed	32031200400100
Closed	30060300103000
Closed	00570600202305
Closed	00882900001500
Closed	00882900001700
Closed	00882900001900
Closed	00882900002000
Closed	00882900002200
Closed	00882900002300
Closed	00882900002400
Closed	00882900002600
Closed	00882900002800
Closed	00882900002900

Accessory Dwelling Units

Index # - File Name: 1.0022 - Single Family Dwellings Data\_Snohomish County.pdf

Closed	00882900003100
Closed	00882900003200
Closed	00882900003300
Closed	00882900003600
Closed	00882900003700
Closed	00882900003900
Closed	00882900004000
Closed	00872800000100
Closed	00872800000300
Closed	00872800000400
Closed	00872800000500
Closed	00872800000600
Closed	00872800000700
Closed	00872800000800
Closed	00872800000900
Closed	00872800001000
Closed	00872800001100
Closed	00872800001200
Closed	00872800001300
Closed	00872800001400
Closed	00872800001500
Closed	00872800001600
Closed	00872800001700
Closed	00872800001800
Closed	00872800000200
Closed	00394400204300
Closed	00473300003408
Closed	00500700201000
Closed	00400700001000
Closed	32042400200700
Closed	00872600001100
Closed	00872600001200
Closed	00872600001300
Closed	00872600001400
Closed	00872600001500
Closed	00872600001600
Closed	00872600001700
Closed	00872600001800
Closed	00872600001900
Closed	00872600002000
Closed	00872600002100
Closed	00872600002200
Closed	00872600002300
Closed	00872600002400
Closed	00872600002500
Closed	00872600002600
Closed	00872600002700

Accessory Dwelling Units

Index # - File Name: 1.0022 - Single Family Dwellings Data\_Snohomish County.pdf

Closed	00872600002800
Closed	00872600002900
Closed	00872600003000
Closed	00872600003100
Closed	00872600003200
Closed	00872600003300
Closed	00872600003400
Closed	00872600003500
Closed	28061700205700
Closed	00590700016305
Closed	00872600004900
Closed	00872600005000
Closed	00872600005100
Closed	00872600005200
Closed	00872600005300
Closed	00872600005400
Closed	00872600005500
Closed	00872600005600
Closed	00872600005700
Closed	00872600005800
Closed	00872600005900
Closed	00872600006000
Closed	00872600006100
Closed	00872600006200
Closed	00872600006300
Closed	00872600006400
Closed	00872600006500
Closed	00872600006600
Closed	00872600006700
Closed	00872600006800
Closed	00872600006900
Closed	00872600007000
Closed	00872600007100
Closed	00872600007200
Closed	28070800302200
Closed	29051200407900
Closed	29051200408100
Closed	00509500006301
Closed	00509500006302
Closed	00509500006303
Closed	31053300401200
Closed	00609700000200
Closed	27052600404100
Closed	00873600000100
Closed	00873600000200
Closed	00873600000300
Closed	27043100208200



Accessory Dwelling Units

Index # - File Name: 1.0022 - Single Family Dwellings Data\_Snohomish County.pdf

Closed	0087360000500
Closed	0087360000600
Closed	00873600001000
Closed	00873600001100
Closed	00873600000800
Closed	00873600001500
Closed	00873600002000
Closed	00873600002100
Closed	00873600002200
Closed	00873600001700
Closed	00873600002600
Closed	00873600002900
Closed	00873600003300
Closed	00873600003400
Closed	00873600003500
Closed	00873600003600
Closed	00873600003800
Closed	00873600003900
Closed	00873600004100
Closed	00873600004300
Closed	00873600004400
Closed	00873600004500
Closed	00551500003500
Closed	00394510901500
Closed	31041300400800
Closed	32053300402900
Closed	27051000408200
Closed	27051000102900
Closed	30062700100400
Closed	00874000000100
Closed	00874000000600
Closed	27051200100500
Closed	00537900001603
Closed	27052400308000
Closed	00480000009700
Closed	00480000009800
Closed	00552500003200
Closed	00590700024304
Closed	31053300401200
Closed	00871800001200
Closed	00871800001300
Closed	00871800001400
Closed	00871800001500
Closed	00871800001600
Closed	00871900002900
Closed	00871900003000
Closed	00871900003100

Accessory Dwelling Units

Index # - File Name: 1.0022 - Single Family Dwellings Data\_Snohomish County.pdf

Closed	00871900003200
Closed	00591200100205
Closed	00509300002307
Closed	00871900002600
Closed	00614700200500
Closed	32090700301000
Closed	00871100000100
Closed	00871100000200
Closed	00871100000300
Closed	00871100000400
Closed	00871100000500
Closed	31060700200500
Closed	00378700100501
Closed	00378700100502
Closed	00378700100503
Closed	00378700100504
Closed	31040500300100
Closed	00427100004400
Closed	00373100400205
Closed	00454500000200
Closed	00871900000400
Closed	00871900000700
Closed	00871900000800
Closed	00871900000900
Closed	00871900001200
Closed	00871900001300
Closed	00871800000300
Closed	00871800000500
Closed	00871800000600
Closed	00871800000700
Closed	00871800002400
Closed	00871800002500
Closed	00871800002600
Closed	00871800002700
Closed	00871700000100
Closed	00871700000200
Closed	00871700000400
Closed	00871700000500
Closed	00871700000600
Closed	00871700000700
Closed	00871700000800
Closed	00871700000900
Closed	00871700001100
Closed	00871700001200
Closed	00871700001300
Closed	00871700001400
Closed	00871700001500

Accessory Dwelling Units

Index # - File Name: 1.0022 - Single Family Dwellings Data\_Snohomish County.pdf

Closed	00556600010400
Closed	00871100000700
Closed	00871100000800
Closed	00871100000900
Closed	00871100001000
Closed	00871100001100
Closed	00871100001200
Closed	00871100001300
Closed	00871100001400
Closed	00509200202304
Closed	29061000401300
Closed	00866800024200
Closed	00866800024400
Closed	00870700000200
Closed	00870700000800
Closed	30061600300300
Closed	00866800019500
Closed	00866800019700
Closed	00866800019900
Closed	29073100300400
Closed	00866800022000
Closed	00866800022200
Closed	00866800022600
Closed	00866800022800
Closed	00866800023000
Closed	00866800023200
Closed	00866800023400
Closed	00866800023600
Closed	00866800024000
Closed	00870400000100
Closed	00870400000200
Closed	00870400000300
Closed	00870400000400
Closed	00870300004000
Closed	00870300004100
Closed	00511900100900
Closed	00870400000800
Closed	00960003903300
Closed	00960010205800
Closed	00529800000700
Closed	00529800000800
Closed	00394406100200
Closed	00385600300504
Closed	30051200401900
Closed	28072000301100
Closed	31053300401200
Closed	00538000006105

Accessory Dwelling Units

Index # - File Name: 1.0022 - Single Family Dwellings Data\_Snohomish County.pdf

Closed	0053800006106
Closed	0053800006107
Closed	32053300103700
Closed	28061600400700
Closed	00552400602002
Closed	00536700001400
Closed	28072700301600
Closed	28072700301700
Closed	27051700305200
Closed	00568700500705
Closed	00568700500706
Closed	00874000000400
Closed	29052600104600
Closed	00874600000100
Closed	00874600000200
Closed	00874600000900
Closed	00875100100300
Closed	00875100100400
Closed	00875100100500
Closed	00875100200100
Closed	00875100200200
Closed	00875100200300
Closed	00875100200400
Closed	00875100200500
Closed	00875100200600
Closed	00877800005800
Closed	00877800005900
Closed	32042300302200
Closed	28051100303100
Closed	32063200304800
Closed	27052700203600
Closed	00885800000200
Closed	00885800000300
Closed	00885800000500
Closed	00885700002200
Closed	00885700002300
Closed	00885700002400
Closed	00885700002500
Closed	00885700002600
Closed	00885700002700
Closed	00704900001900
Closed	00374700006100
Closed	00885800001000
Closed	30052100406300
Closed	00509200201502
Closed	00509200201503
Closed	29062000103300

Accessory Dwelling Units

Index # - File Name: 1.0022 - Single Family Dwellings Data\_Snohomish County.pdf

Closed	30060600402400
Closed	31052500101200
Closed	00885700000100
Closed	00885700000200
Closed	00885700000300
Closed	00885700000400
Closed	00885700000500
Closed	00885700000600
Closed	00885700001200
Closed	00885700001300
Closed	00885700001400
Closed	00885400000100
Closed	00885400000200
Closed	00885400000300
Closed	00885400000400
Closed	00557200400400
Closed	28082100400800
Closed	00886000000100
Closed	00886000000300
Closed	00886000001800
Closed	00538000001502
Closed	00538000001503
Closed	00538000001504
Closed	00886000001400
Closed	00516700006300
Closed	00886300000300
Closed	00886300000400
Closed	00886300000500
Closed	00886300000600
Closed	00886400003100
Closed	00886400003200
Closed	00886400003400
Closed	00886400003500
Closed	00374900000600
Closed	27052300201100
Closed	00473600005100
Closed	00886900001600
Closed	00373800601105
Closed	00886900000700
Closed	00886900000900
Closed	00886900006800
Closed	00886900006900
Closed	00886900008100
Closed	00886900008600
Closed	00886900011800
Closed	00886900012000
Closed	00896200000800

Accessory Dwelling Units

Index # - File Name: 1.0022 - Single Family Dwellings Data\_Snohomish County.pdf

Closed	00896200000900
Closed	00896200001000
Closed	00896200001100
Closed	00896200001200
Closed	00896200001300
Closed	00896200001400
Closed	00896200001500
Closed	00896200001600
Closed	00896200001700
Closed	00896200001800
Closed	00896200001900
Closed	00896200002100
Closed	00896200002200
Closed	00896200002300
Closed	00896200002400
Closed	00896200002500
Closed	00896200002600
Closed	00896200002700
Closed	00896200002800
Closed	00896200002900
Closed	00896200003000
Closed	00647500003500
Closed	00960005304600
Closed	00960005302400
Closed	00882000000100
Closed	00882000000200
Closed	00882000000300
Closed	00882000000500
Closed	00882000000600
Closed	00882000000700
Closed	00882000000800
Closed	00882000000900
Closed	00882000001000
Closed	00882000001100
Closed	00882000001200
Closed	00882000001400
Closed	00882000001600
Closed	00882000001700
Closed	00882000001800
Closed	00882000001900
Closed	00882000002000
Closed	00480000007900
Closed	00881200000400
Closed	28060600201400
Closed	29051200407000
Closed	00882000002200
Closed	00882000002300

Accessory Dwelling Units

Index # - File Name: 1.0022 - Single Family Dwellings Data\_Snohomish County.pdf

Closed	00882000002400
Closed	00882000002600
Closed	00882000002700
Closed	00882000002800
Closed	00882000002900
Closed	00882000003000
Closed	00882000003100
Closed	00882000003200
Closed	00882000003300
Closed	00882000003400
Closed	00882000003500
Closed	00882000003600
Closed	00882000003700
Closed	00882000003800
Closed	00882000003900
Closed	00882000004000
Closed	00882000004100
Closed	00882000004300
Closed	00882000004400
Closed	00882000004500
Closed	00882000004600
Closed	00882000004700
Closed	00882000004800
Closed	00882000004900
Closed	00882000005000
Closed	00882000005100
Closed	00882000005200
Closed	00882000005300
Closed	00882000005400
Closed	00882000005500
Closed	00882000005600
Closed	00882000005700
Closed	00882000005800
Closed	00882000005900
Closed	00882000006000
Closed	00882000006100
Closed	00882000006200
Closed	00882000006300
Closed	31043200300700
Closed	00492900000600
Closed	31043200300500
Closed	31043200300600
Closed	32063000401600
Closed	00464600001900
Closed	00646700000200
Closed	00543400005500
Closed	32063300304400

Accessory Dwelling Units

Index # - File Name: 1.0022 - Single Family Dwellings Data\_Snohomish County.pdf

Closed	00882200000100
Closed	00882200000200
Closed	00882200000300
Closed	00882200000400
Closed	00882200001200
Closed	00882200001300
Closed	00882200001400
Closed	00882200001500
Closed	00882200001600
Closed	00882200001700
Closed	00882200001800
Closed	00882200001900
Closed	00882200002000
Closed	00882200002100
Closed	00882200002200
Closed	00882200002300
Closed	00882200002400
Closed	00394403900900
Closed	00577700502100
Closed	00882800200100
Closed	00882800200200
Closed	00882800200300
Closed	00882800200400
Closed	00882800200500
Closed	00882800200600
Closed	00882800200700
Closed	00882800200800
Closed	00882800200900
Closed	00882800201000
Closed	00882800201100
Closed	00882800201200
Closed	00882800201300
Closed	00882800201400
Closed	00882800201500
Closed	00882800201600
Closed	00882800201700
Closed	00882800201800
Closed	00882800201900
Closed	00882800202000
Closed	00882800202100
Closed	00882800202200
Closed	00882800202300
Closed	00882800202400
Closed	00882800202500
Closed	00882800202600
Closed	00882800202700
Closed	00882800202800



Accessory Dwelling Units

Index # - File Name: 1.0022 - Single Family Dwellings Data\_Snohomish County.pdf

Closed	00882800202900
Closed	00882800203000
Closed	00882800203100
Closed	00882800203200
Closed	00882800203300
Closed	00882800203400
Closed	00882800203500
Closed	00882800203600
Closed	28081900201600
Closed	31050100101400
Closed	00882200000700
Closed	00882200000800
Closed	00882200001000
Closed	28061600402700
Closed	28070700200500
Closed	00882800203900
Closed	00882800204200
Closed	00882800205500
Closed	00882800205600
Closed	00882800205700
Closed	00882800205800
Closed	00882800300100
Closed	00882800300200
Closed	00882800300300
Closed	00882800300400
Closed	00882800300500
Closed	00882800300600
Closed	00882800204600
Closed	00882800204700
Closed	00882800204800
Closed	00882800205200
Closed	00882800301000
Closed	00882800301100
Closed	00882800301300
Closed	00882800301500
Closed	00882800301600
Closed	00882800301900
Closed	00882800302000
Closed	00882800302100
Closed	00882800302700
Closed	00882600000400
Closed	00882600000500
Closed	00882600000600
Closed	00882600000700
Closed	00882600000800
Closed	00882600000900
Closed	00882600001000

Accessory Dwelling Units

Index # - File Name: 1.0022 - Single Family Dwellings Data\_Snohomish County.pdf

Closed	00882600001100
Closed	00882600001200
Closed	00882600001300
Closed	00882600001400
Closed	00882600001500
Closed	00882600001600
Closed	00882600001700
Closed	00882600001800
Closed	00882600001900
Closed	00882600002000
Closed	00882600002100
Closed	00461000500115
Closed	00882700000200
Closed	00882700000300
Closed	00882800302500
Closed	00882700000600
Closed	00882700000800
Closed	00882700000900
Closed	00882700001100
Closed	00882700001200
Closed	00882700001400
Closed	00882700001500
Closed	00882700001600
Closed	00882700002300
Closed	00882700001800
Closed	00882700001900
Closed	00882700002100
Closed	00882700003300
Closed	00882700003400
Closed	00882700004400
Closed	00882700004500
Closed	00882700003900
Closed	00883000001500
Closed	00883000001600
Closed	00883000001700
Closed	00883000001800
Closed	27072900402900
Closed	27062800103500
Closed	30050300304700
Closed	30050300304800
Closed	00403900020307
Closed	28082800101800
Closed	00551400003700
Closed	00389400300201
Closed	32052200102000
Closed	00960005304000
Closed	32051800102300

Accessory Dwelling Units

Index # - File Name: 1.0022 - Single Family Dwellings Data\_Snohomish County.pdf

Closed	0088300000500
Closed	0088300000600
Closed	0088300000700
Closed	0088300000800
Closed	0088300000900
Closed	0088300001000
Closed	0088300001100
Closed	0088300001200
Closed	00374800005705
Closed	00543800002601
Closed	31043400400200
Closed	0088350000200
Closed	0088350000300
Closed	0088350000400
Closed	0088350000700
Closed	0088350000800
Closed	0088350000900
Closed	00543400002400
Closed	00883500001300
Closed	00883500001500
Closed	00883500002100
Closed	00883500002400
Closed	00490400001100
Closed	00394401608000
Closed	00883500002800
Closed	00499100106200
Closed	30061400201200
Closed	00556800501600
Closed	00883800000100
Closed	00883800000200
Closed	00883800000300
Closed	00883800000700
Closed	00883800001100
Closed	00883800001200
Closed	00883800001300
Closed	00492900000901
Closed	00479901000800
Closed	00883800001900
Closed	00883800002100
Closed	00883800002200
Closed	00883800002300
Closed	00883800002400
Closed	00883800002500
Closed	00883800002600
Closed	00883800002700
Closed	00883800002800
Closed	00883800003000

Accessory Dwelling Units

Index # - File Name: 1.0022 - Single Family Dwellings Data\_Snohomish County.pdf

Closed	00466800001700
Closed	00466200004100
Closed	00509500001703
Closed	00403900020306
Closed	32070800102600
Closed	00403900020305
Closed	32063200304200
Closed	32063200304100
Closed	32063200300700
Closed	00884100000200
Closed	00884100000300
Closed	00884100000400
Closed	00884100000500
Closed	00884100000600
Closed	00884100000700
Closed	00884100000800
Closed	00884100000900
Closed	00884100001000
Closed	00884100001100
Closed	00884100001200
Closed	00884100001300
Closed	00884100001400
Closed	00884100001500
Closed	00884100001600
Closed	00884100001700
Closed	00884100001800
Closed	00884100001900
Closed	00884100002000
Closed	00884100002100
Closed	00884100002200
Closed	00884100002300
Closed	00884200000100
Closed	00884200000200
Closed	30052200208700
Closed	30052200209100
Closed	00884200000500
Closed	00885100001800
Closed	30040300303200
Closed	00884300001600
Closed	00884300001700
Closed	30061900302200
Closed	30061900302400
Closed	32061000202400
Closed	00884300000100
Closed	00884300000300
Closed	00884300001100
Closed	00884300000900

Accessory Dwelling Units

Index # - File Name: 1.0022 - Single Family Dwellings Data\_Snohomish County.pdf

Closed	31042200401200
Closed	32053300202900
Closed	00876100301200
Closed	00597400001600
Closed	30040200403500
Closed	00885100001600
Closed	00885100001700
Closed	00885100001900
Closed	00885100002000
Closed	00885100002200
Closed	00885100002300
Closed	00466900006200
Closed	00885000000100
Closed	00885000000300
Closed	00885000000400
Closed	00885000000500
Closed	00885000000700
Closed	00885000000900
Closed	00885000001000
Closed	00885000001100
Closed	00885000001200
Closed	00885000001300
Closed	00885000001400
Closed	00885000001500
Closed	00885000001600
Closed	00885000001700
Closed	00457100001406
Closed	00885100001100
Closed	00885200000100
Closed	00885200000200
Closed	00885200000300
Closed	00885200000400
Closed	00885200000700
Closed	00885200000800
Closed	00885200001100
Closed	00885200001200
Closed	00885200001500
Closed	00885200001600
Closed	27062000102800
Closed	30052100404900
Closed	00466100000500
Closed	00385300008800
Closed	00875600000100
Closed	00875600000200
Closed	00875600000400
Closed	00875600000500
Closed	00875600000600

Accessory Dwelling Units

Index # - File Name: 1.0022 - Single Family Dwellings Data\_Snohomish County.pdf

Closed	00500100000800
Closed	31043000201900
Closed	00876300000200
Closed	00876300000300
Closed	00876300000400
Closed	00876300000500
Closed	00876300000600
Closed	00876300000700
Closed	00876300000800
Closed	00876300000900
Closed	00876300001000
Closed	00876300001100
Closed	00876300001200
Closed	00876300001300
Closed	00876300001400
Closed	00876300001500
Closed	00876300001600
Closed	27071800401300
Closed	00875000000100
Closed	00875000000200
Closed	00875000000300
Closed	00875000000400
Closed	00875000000500
Closed	00875000000600
Closed	00875000000700
Closed	00875000000800
Closed	00875000000900
Closed	00875000001000
Closed	00875000001100
Closed	00875000001200
Closed	00875000001300
Closed	00875000001400
Closed	00875000001500
Closed	00875000001600
Closed	00875000001800
Closed	00875000002000
Closed	00875000002200
Closed	00875000002300
Closed	00875000002400
Closed	00875000002500
Closed	00875000002600
Closed	00875000002700
Closed	00875000002900
Closed	00875000003000
Closed	00875000003100
Closed	00875000003200
Closed	00875000003300

Accessory Dwelling Units

Index # - File Name: 1.0022 - Single Family Dwellings Data\_Snohomish County.pdf

Closed	0087500003400
Closed	0087500003500
Closed	0087500003600
Closed	0087500003700
Closed	0087500003800
Closed	0087500003900
Closed	0087500004000
Closed	0087500004100
Closed	0087500004200
Closed	0087500004300
Closed	0087500004400
Closed	0087500004500
Closed	0087500004600
Closed	0087500004700
Closed	0087500004800
Closed	0087500004900
Closed	0087500005000
Closed	0087500005100
Closed	0087500005200
Closed	0087500005300
Closed	0087500005500
Closed	0087500005600
Closed	0087500005700
Closed	0087500005800
Closed	0087500005900
Closed	0087500006000
Closed	0054380003501
Closed	00875100200700
Closed	00875100200800
Closed	00875100200900
Closed	00874900001900
Closed	00874900002000
Closed	00874900002100
Closed	00874900002200
Closed	00874900002300
Closed	00874900002400
Closed	00874900002500
Closed	00874900002600
Closed	00874900002700
Closed	00874900002800
Closed	00875100100100
Closed	00875100100200
Closed	29062300201000
Closed	00874900000100
Closed	00874900000300
Closed	00874900000400
Closed	00874900000500

Accessory Dwelling Units

Index # - File Name: 1.0022 - Single Family Dwellings Data\_Snohomish County.pdf

Closed	0087490000600
Closed	0087490000700
Closed	0087490000900
Closed	0087490001100
Closed	0087490001400
Closed	0087490001500
Closed	0087490001700
Closed	0087460001100
Closed	00574800101101
Closed	0087460000300
Closed	0087460000400
Closed	0087460000500
Closed	29052600104700
Closed	0047840000700
Closed	29060400402400
Closed	29060400403900
Closed	0087400000500
Closed	31041100201500
Closed	29052600104500
Closed	27080700201800
Closed	31041000201600
Closed	31041000201800
Closed	28072700301800
Closed	28072700301900
Closed	31062900300400
Closed	00394401802800
Closed	00577700603700
Closed	00577700605400
Closed	00490300000300
Closed	00877200000100
Closed	00877200000200
Closed	00877200000300
Closed	00877200000400
Closed	00877200000500
Closed	00877200000600
Closed	00877200000700
Closed	00877200000800
Closed	00877200000900
Closed	00877200001000
Closed	00877200001100
Closed	00877200001200
Closed	00877200001300
Closed	00877200001400
Closed	00877200001500
Closed	00877200001600
Closed	00877200001700
Closed	00877200001800



Accessory Dwelling Units

Index # - File Name: 1.0022 - Single Family Dwellings Data\_Snohomish County.pdf

Closed	00877200001900
Closed	00877200002000
Closed	00877200002100
Closed	00877200002200
Closed	00877200002300
Closed	00877200002400
Closed	00877200002500
Closed	00877200002600
Closed	00877200002700
Closed	00877200002800
Closed	00877200002900
Closed	00877200003000
Closed	00877200003100
Closed	00877200003200
Closed	00877200003300
Closed	00877200003400
Closed	00877200003500
Closed	00877200003600
Closed	00877200003700
Closed	00877200003800
Closed	00877200003900
Closed	00877200004000
Closed	00877200004100
Closed	00877200004200
Closed	00877200004300
Closed	00877200004400
Closed	00877200004500
Closed	00877200004600
Closed	00877200004700
Closed	00877200004800
Closed	00877200004900
Closed	00877200005000
Closed	00877200005100
Closed	00877200005200
Closed	00877200005300
Closed	00877200005400
Closed	00877200005600
Closed	00877200005700
Closed	00877200005800
Closed	00877200005900
Closed	00877200006000
Closed	00877200006100
Closed	00877200006200
Closed	00877200006300
Closed	00877200006400
Closed	00877200006500
Closed	00877200006600

Accessory Dwelling Units

Index # - File Name: 1.0022 - Single Family Dwellings Data\_Snohomish County.pdf

Closed	00877200006700
Closed	00877200006800
Closed	00877200006900
Closed	00877200007000
Closed	00877200007100
Closed	00877200007200
Closed	00877200007300
Closed	00877200007400
Closed	00877200007500
Closed	00877200007600
Closed	00877200007700
Closed	00877200007800
Closed	00877200007900
Closed	00877200008000
Closed	00877200008100
Closed	00877200008200
Closed	00877200008300
Closed	00877200008400
Closed	00877200008500
Closed	00877200008600
Closed	00877200008700
Closed	00877200008800
Closed	00877200008900
Closed	00877200009000
Closed	00877200009100
Closed	00877200009200
Closed	00877200009300
Closed	00877200009400
Closed	00877200009500
Closed	00877200009600
Closed	00877200009700
Closed	00877200009800
Closed	00877200010000
Closed	00877200010100
Closed	00877200010200
Closed	00877200010300
Closed	00877200010400
Closed	00877200010500
Closed	00877200010600
Closed	00877200010700
Closed	00877200010800
Closed	00877200010900
Closed	00877200011000
Closed	00877200011100
Closed	00877200011200
Closed	00877200011300
Closed	00877200011400

Accessory Dwelling Units

Index # - File Name: 1.0022 - Single Family Dwellings Data\_Snohomish County.pdf

Closed	00877200011500
Closed	00877200011600
Closed	00877200011700
Closed	00877200011800
Closed	00877200011900
Closed	00877200012000
Closed	00877200012100
Closed	00877200012200
Closed	00877200012300
Closed	00877200012400
Closed	00877200012500
Closed	00877200012600
Closed	00877200012700
Closed	00877200012800
Closed	00877200012900
Closed	00877200013000
Closed	00877200013100
Closed	00877200013200
Closed	00877200013300
Closed	00877200013400
Closed	00877200013500
Closed	00877200013600
Closed	00877200013700
Closed	00877200013800
Closed	00877200013900
Closed	00877200014000
Closed	00877200014100
Closed	00877200014200
Closed	00877200014300
Closed	00877200014400
Closed	00877200014500
Closed	00877200014600
Closed	00877200014700
Closed	00877200014800
Closed	00877200014900
Closed	00877200015000
Closed	00877200015100
Closed	00877200015200
Closed	00877200015300
Closed	00877200015400
Closed	00877200015500
Closed	00877200015600
Closed	00877200015700
Closed	00877700000600
Closed	00877800000100
Closed	00877800000200
Closed	00877800000400

Accessory Dwelling Units

Index # - File Name: 1.0022 - Single Family Dwellings Data\_Snohomish County.pdf

Closed	00877800000500
Closed	00877800000600
Closed	00394406300700
Closed	00394403200203
Closed	00551400005701
Closed	29060900200600
Closed	29062300201800
Closed	27061900304400
Closed	00877700000200
Closed	00877700000300
Closed	00877700000800
Closed	00877700000900
Closed	00877700001000
Closed	00877700001100
Closed	00877700001200
Closed	00877700001300
Closed	00877700001400
Closed	00492000304400
Closed	00428800000400
Closed	00878100100100
Closed	00878100100200
Closed	00878100100300
Closed	00878100100400
Closed	00878100100500
Closed	00878100100600
Closed	00878100100700
Closed	00878100100800
Closed	00878100100900
Closed	00878100101000
Closed	00878100101200
Closed	00878100101500
Closed	00878100101600
Closed	00878100101700
Closed	00878100101800
Closed	00878100101900
Closed	00878100102000
Closed	00878100102100
Closed	00878100102200
Closed	00878100102300
Closed	00878100102400
Closed	00878100102500
Closed	00878100102600
Closed	00878100102700
Closed	00878100102800
Closed	00878100102900
Closed	00878100103000
Closed	00878100103100

Accessory Dwelling Units

Index # - File Name: 1.0022 - Single Family Dwellings Data\_Snohomish County.pdf

Closed	00878100103200
Closed	00878100103400
Closed	00878100103500
Closed	00878100103700
Closed	00878100103800
Closed	00878100103900
Closed	00878100200100
Closed	00878100200200
Closed	00878100200300
Closed	00878100200400
Closed	00878100200500
Closed	00878100200600
Closed	00878100200700
Closed	00878100200800
Closed	00878100200900
Closed	00878100201000
Closed	00878100201100
Closed	00878100201200
Closed	00878100201300
Closed	00878100201400
Closed	00878100201500
Closed	00878100201600
Closed	00878100201700
Closed	00878100201800
Closed	00878100201900
Closed	00394406300502
Closed	00419500000105
Closed	00877400000100
Closed	00877400000200
Closed	00877400000300
Closed	00877400000400
Closed	00877400000500
Closed	00877400000600
Closed	00877400000700
Closed	00877400000800
Closed	00877400000900
Closed	00877400001000
Closed	00877400001100
Closed	00877400001200
Closed	00877400001300
Closed	00877400001400
Closed	00877400001500
Closed	00877400001600
Closed	00877400001700
Closed	00877400001800
Closed	00877400001900
Closed	00877400002000

Accessory Dwelling Units

Index # - File Name: 1.0022 - Single Family Dwellings Data\_Snohomish County.pdf

Closed	00877400002100
Closed	00877400002200
Closed	00877400002400
Closed	00877400002500
Closed	00877400002600
Closed	00877400002700
Closed	00877400002800
Closed	30061000300300
Closed	00372801100903
Closed	00372801101003
Closed	29060400101600
Closed	00491900400100
Closed	31043500403900
Closed	00499100201500
Closed	32100400201300
Closed	32042500102600
Closed	00480800202000
Closed	00877800001000
Closed	00877800001100
Closed	00877800001200
Closed	00877800001300
Closed	00877800001400
Closed	00877800001500
Closed	00877800001600
Closed	00877800001700
Closed	00877800001900
Closed	00877800002000
Closed	00877800002100
Closed	00877800002200
Closed	00877800002300
Closed	00877800002400
Closed	00877800002500
Closed	00877800002600
Closed	00877800002700
Closed	00877800002800
Closed	00877800002900
Closed	00877800003000
Closed	00877800003100
Closed	00877800003200
Closed	00877800003300
Closed	00877800003400
Closed	00877800003500
Closed	00877800003600
Closed	00877800003700
Closed	00877800003800
Closed	00877800003900
Closed	00877800004000

Accessory Dwelling Units

Index # - File Name: 1.0022 - Single Family Dwellings Data\_Snohomish County.pdf

Closed	00877800004100
Closed	00877800004200
Closed	00877800004300
Closed	00877800004400
Closed	00877800004500
Closed	00877800004600
Closed	00877800004700
Closed	00877800004800
Closed	00877800004900
Closed	00877800005000
Closed	00877800005100
Closed	00877800005200
Closed	00877800005300
Closed	00877800005400
Closed	00877800005500
Closed	00877800005600
Closed	00877800005700
Closed	00877800006000
Closed	00877800006100
Closed	00877800006200
Closed	00500700200900
Closed	00373000302507
Closed	27061700301100
Closed	00875700000100
Closed	00875700000200
Closed	00875700000300
Closed	00875700000400
Closed	00875700000500
Closed	00875700000600
Closed	00875700000700
Closed	00875700000800
Closed	00875700000900
Closed	00875700001000
Closed	00473600003500
Closed	28083400101800
Closed	00876500000200
Closed	00551500002700
Closed	32052600401000
Closed	00876200000800
Closed	00574400000602
Closed	00568700500409
Closed	00568700500410
Closed	00568700500411
Closed	00568700500412
Closed	00568700500413
Closed	00568700500414
Closed	00394401400003

Accessory Dwelling Units

Index # - File Name: 1.0022 - Single Family Dwellings Data\_Snohomish County.pdf

Closed	27050200101600
Closed	00373800400502
Closed	00538200004600
Closed	30051100405000
Closed	00482900005600
Closed	00494600200908
Closed	30073000401600
Closed	32090800400700
Closed	00876800000100
Closed	00876800000200
Closed	00876800000400
Closed	00876800000500
Closed	00876800000700
Closed	00876800000900
Closed	00876800001000
Closed	00876800001100
Closed	00876800001200
Closed	00552300301101
Closed	30063400400300
Closed	31042700305000
Closed	30052100111300
Closed	30052100111400
Closed	28063200402900
Closed	00373002500601
Closed	00373002500602
Closed	00373002500603
Closed	00876900000100
Closed	00876900000200
Closed	00876900000300
Closed	00876900000400
Closed	00876900000500
Closed	00876900000600
Closed	00876900000700
Closed	00876900000800
Closed	00876900000900
Closed	30040700402900
Closed	27070200203200
Closed	00419500002100
Closed	31043200201300
Closed	00611300006400
Closed	31041200302100
Closed	00373100400207
Closed	00373001401001
Closed	00373001401002
Closed	00373001401003
Closed	00373001401004
Closed	28073000405400



Accessory Dwelling Units

Index # - File Name: 1.0022 - Single Family Dwellings Data\_Snohomish County.pdf

Closed	00512100002600
Closed	00373001900104
Closed	29061400102000
Closed	27080700200500
Closed	00539000003100
Closed	31060400402000
Closed	31060500104400
Closed	27061800303600
Closed	27061800303800
Closed	00373001401101
Closed	00373001401102
Closed	00373001401103
Closed	00590700020300
Closed	00960002701200
Closed	00877100000700
Closed	00877100000300
Closed	00877100000400
Closed	00877200015800
Closed	00877200015900
Closed	00877200016000
Closed	00877200016100
Closed	00877200016200
Closed	00877200016300
Closed	00877200016400
Closed	00877200016500
Closed	00877200016600
Closed	00877200016700
Closed	00877200016800
Closed	00877200016900
Closed	00877200017000
Closed	00877200017100
Closed	00877200017200
Closed	00877200017300
Closed	00877200017400
Closed	00877200017500
Closed	00877200017600
Closed	00877200017700
Closed	00877200017800
Closed	00877200017900
Closed	00877200018000
Closed	00877200018100
Closed	00877200018200
Closed	00877200018300
Closed	31051900104400
Closed	28060400102800
Closed	00611300008400
Closed	31043000300100

Accessory Dwelling Units

Index # - File Name: 1.0022 - Single Family Dwellings Data\_Snohomish County.pdf

Closed	00538000010803
Closed	00877300000100
Closed	31042300402600
Closed	30051500401800
Closed	30051500402000
Closed	30051500402100
Closed	30061400100500
Closed	00880300003400
Closed	00882600000300
Closed	00882600002200
Closed	00882600002300
Closed	00879300002900
Closed	00879300003500
Closed	00879300003600
Closed	00879300003700
Closed	00879300003900
Closed	00879300004000
Closed	28061600201100
Closed	29062300201600
Closed	31041300200100
Closed	31043400403600
Closed	29061400101300
Closed	00879500000100
Closed	00879300000500
Closed	00879300000600
Closed	00879300000800
Closed	00879300001000
Closed	00879300001800
Closed	00879300001900
Closed	00879300001400
Closed	00879300001500
Closed	00879500000200
Closed	00879500000300
Closed	00879500000400
Closed	00879500000500
Closed	00879500000600
Closed	00879500000700
Closed	00879500000800
Closed	00879500000900
Closed	00879500001000
Closed	31050400401300
Closed	00879500001100
Closed	00879500001200
Closed	00879500001300
Closed	00879500001400
Closed	00879500001500
Closed	00879500001600

Accessory Dwelling Units

Index # - File Name: 1.0022 - Single Family Dwellings Data\_Snohomish County.pdf

Closed	00879500001700
Closed	00879500001800
Closed	00879500001900
Closed	00879500002000
Closed	00879500002100
Closed	00879500002200
Closed	00879500002300
Closed	00879500002400
Closed	00879500002500
Closed	00879500002600
Closed	00879500002700
Closed	00879500002800
Closed	00879500002900
Closed	00879500003000
Closed	00879500003100
Closed	00879500003200
Closed	00879500003300
Closed	00879500003400
Closed	00879500003500
Closed	00879500003600
Closed	00879500003700
Closed	00879500003800
Closed	00879500003900
Closed	00879500004000
Closed	00879500004100
Closed	00879500004200
Closed	00879500004300
Closed	00879500004400
Closed	00879500004500
Closed	00879500004600
Closed	00879500004700
Closed	00879500004800
Closed	00879500004900
Closed	00879500005000
Closed	00879500005100
Closed	00879500005200
Closed	00879500005300
Closed	00879500005400
Closed	00879500005500
Closed	00879500005600
Closed	00879500005700
Closed	00879500005800
Closed	00879500005900
Closed	00879500006000
Closed	00879500006100
Closed	00879500006200
Closed	00879500006300

Accessory Dwelling Units

Index # - File Name: 1.0022 - Single Family Dwellings Data\_Snohomish County.pdf

Closed	00879500006400
Closed	00879500006500
Closed	00879500006600
Closed	00879500006700
Closed	00879500006800
Closed	00879500006900
Closed	00879500007000
Closed	00879500007100
Closed	00879500007200
Closed	00879500007300
Closed	00879500007400
Closed	00879500007500
Closed	00879500007600
Closed	00879500007700
Closed	00879500007800
Closed	00879500007900
Closed	00879500008000
Closed	30051500401900
Closed	32053000101200
Closed	32100800400100
Closed	00427100003800
Closed	27052000102000
Closed	00394406400801
Closed	28072500302100
Closed	28072500302200
Closed	31041300201100
Closed	27051400107300
Closed	00878700000100
Closed	00878700000200
Closed	00878700000300
Closed	00878700000400
Closed	00878700000500
Closed	00878700000600
Closed	00878700000700
Closed	00878700000800
Closed	00878700000900
Closed	00878700001100
Closed	00878700001200
Closed	00878700001300
Closed	00627600000300
Closed	30062600200200
Closed	00878800000100
Closed	00878800000200
Closed	00878800000300
Closed	00878800000400
Closed	00878800000500
Closed	00878800000600

Accessory Dwelling Units

Index # - File Name: 1.0022 - Single Family Dwellings Data\_Snohomish County.pdf

Closed	0087880000700
Closed	0087880000800
Closed	0087880000900
Closed	0087880001100
Closed	0087880001200
Closed	0087880001300
Closed	0087880001400
Closed	0087880001500
Closed	0087880001600
Closed	0087880001700
Closed	0087880001800
Closed	0087880002100
Closed	0087880002300
Closed	0087880002400
Closed	0087880002500
Closed	0087880002600
Closed	0087880002700
Closed	0087880002800
Closed	0087880002900
Closed	0087880003200
Closed	0087880003300
Closed	0087880003400
Closed	0087880003500
Closed	0087880003600
Closed	0087880001000
Closed	0087880001900
Closed	0087880002000
Closed	0087880002200
Closed	0087880003000
Closed	0087880003100
Closed	31041900100600
Closed	29061900200700
Closed	27050300303500
Closed	30060700202900
Closed	30060600102200
Closed	27052000102100
Closed	00414400201000
Closed	30060700100400
Closed	00879000000100
Closed	00879000000200
Closed	00879000000300
Closed	00879000000400
Closed	00879000000500
Closed	00879000000600
Closed	00878900000100
Closed	00878900000200
Closed	00878900000300

Accessory Dwelling Units

Index # - File Name: 1.0022 - Single Family Dwellings Data\_Snohomish County.pdf

Closed	0087890000400
Closed	0087890000600
Closed	0087890000700
Closed	0087890000800
Closed	0087890000900
Closed	0087890001000
Closed	0087890001100
Closed	0087890001300
Closed	0087890001400
Closed	0087890001500
Closed	0087890001600
Closed	0087890001700
Closed	0087890001800
Closed	0087890001900
Closed	0087890002000
Closed	0087890002100
Closed	0087890002200
Closed	0087890002300
Closed	30062900100500
Closed	00590700005500
Closed	29062300201200
Closed	30063200400600
Closed	00960010609100
Closed	00375000001101
Closed	30041700400100
Closed	00960011800300
Closed	00960011800900
Closed	00960011801400
Closed	00960011801500
Closed	00960011801600
Closed	00960011801700
Closed	00960011801800
Closed	00960011801900
Closed	00960011802000
Closed	00960011802100
Closed	00960011802200
Closed	00960011802300
Closed	00960011802400
Closed	00960011802500
Closed	00960011802600
Closed	00960011802700
Closed	00960011802800
Closed	00960011802900
Closed	00960011803000
Closed	00960011803100
Closed	00960011803200
Closed	00960011803300

Accessory Dwelling Units

Index # - File Name: 1.0022 - Single Family Dwellings Data\_Snohomish County.pdf

Closed	00960011803500
Closed	00607100001400
Closed	32063400400200
Closed	32062800401000
Closed	00421100000300
Closed	00509500001701
Closed	00881500000100
Closed	00881500000200
Closed	00881500000300
Closed	00881500000400
Closed	00427100002300
Closed	32041300403200
Closed	29060900200600
Closed	00543400003400
Closed	28073400301200
Closed	28071200400300
Closed	28073000201700
Closed	00881100000100
Closed	00881100000200
Closed	00881100000300
Closed	00881100000800
Closed	00881100000900
Closed	00881100001100
Closed	00881100001200
Closed	00881100001300
Closed	00881100001400
Closed	00881100001500
Closed	00881100001600
Closed	00881100001700
Closed	00881100001800
Closed	00520200000300
Closed	00881200000100
Closed	00881200000200
Closed	00881200000800
Closed	00881200000900
Closed	00881200001000
Closed	00881200001100
Closed	00881200001200
Closed	00881200001300
Closed	00881200001400
Closed	00881200001500
Closed	00881200001600
Closed	00881200001700
Closed	00881200001800
Closed	00881200001900
Closed	00515300000503
Closed	31040500401100

Accessory Dwelling Units

Index # - File Name: 1.0022 - Single Family Dwellings Data\_Snohomish County.pdf

Closed	00880300005800
Closed	00880300005900
Closed	00880300006000
Closed	00880300006100
Closed	00880300006200
Closed	00880300006300
Closed	00880300006400
Closed	00880300006500
Closed	00880300006600
Closed	00880300006800
Closed	00880300006900
Closed	00880300007000
Closed	00880300007100
Closed	00880300007200
Closed	00880300007300
Closed	00880300007400
Closed	00880300007500
Closed	00880300007600
Closed	00880300007700
Closed	00880300007800
Closed	00880300007900
Closed	00880300008000
Closed	00880300008100
Closed	00880300008200
Closed	00880300004500
Closed	00880300005100
Closed	00880300005200
Closed	00880300005300
Closed	00880300005400
Closed	00880300005500
Closed	00880300005600
Closed	00880400000900
Closed	00880400001900
Closed	31041800300700
Closed	00467100011900
Closed	27062800103600
Closed	00511900200501
Closed	00403900016602
Closed	00372901000917
Closed	00466200001700
Closed	32052100204200
Closed	00880700000100
Closed	00880700000200
Closed	00880700000300
Closed	00880700000400
Closed	00880700000500
Closed	00880700000600



Accessory Dwelling Units

Index # - File Name: 1.0022 - Single Family Dwellings Data\_Snohomish County.pdf

Closed	00880700000700
Closed	00880700000800
Closed	00880700000900
Closed	00880700001000
Closed	00880700001100
Closed	00879600000900
Closed	00403800014709
Closed	28072900103100
Closed	00879800000200
Closed	00879800000300
Closed	00879800000800
Closed	00879800000900
Closed	00879800001000
Closed	00879800001100
Closed	00879800001200
Closed	00879800001300
Closed	00879800001400
Closed	00879800002100
Closed	00879800002200
Closed	00879800002300
Closed	00879800002400
Closed	27070100202400
Closed	00879800003200
Closed	00879800003300
Closed	30072000401700
Closed	00611300021602
Closed	00394401803000
Closed	00394401702700
Closed	00394401702900
Closed	32051900402500
Closed	00537900002003
Closed	00537900002004
Closed	00537900002005
Closed	27061900304000
Closed	00403900021700
Closed	30061300305500
Closed	30061300305600
Closed	00879900000100
Closed	00879900000200
Closed	00879900000300
Closed	00879900000400
Closed	00879900000500
Closed	00879900000600
Closed	00879900000700
Closed	00879900000800
Closed	00879900000900
Closed	27102000302400

Accessory Dwelling Units

Index # - File Name: 1.0022 - Single Family Dwellings Data\_Snohomish County.pdf

Closed	30051300101300
Closed	30073100401500
Closed	00517000002401
Closed	00374800004501
Closed	00374800004502
Closed	31043500403000
Closed	00385500500502
Closed	30050300205400
Closed	30050300205300
Closed	00880100000100
Closed	00880100000200
Closed	00880100000300
Closed	00880100000400
Closed	00880100000500
Closed	00414400201300
Closed	31052400100100
Closed	00607100002600
Closed	00466600002400
Closed	00394403907200
Closed	00880200000100
Closed	00880200000200
Closed	00880200000400
Closed	00880200000500
Closed	00880200000700
Closed	00880200000800
Closed	00586900000504
Closed	29051200408200
Closed	28070700101300
Closed	00960010608700
Closed	00577600200800
Closed	00880300000100
Closed	00880300000200
Closed	00880300000300
Closed	00880300000400
Closed	00880300000500
Closed	00880300000600
Closed	00880300000700
Closed	00880300000800
Closed	00880300000900
Closed	00880300001000
Closed	00880300001100
Closed	00880300001200
Closed	00880300001300
Closed	00880300001400
Closed	00880300001500
Closed	00880300001600
Closed	00880300001700

Accessory Dwelling Units

Index # - File Name: 1.0022 - Single Family Dwellings Data\_Snohomish County.pdf

Closed	00880300002300
Closed	00880300002400
Closed	00880300002600
Closed	00880300002700
Closed	00880300002800
Closed	00880300002900
Closed	00880300003000
Closed	00880300003100
Closed	00880300003200
Closed	00880300003300
Closed	00880300003500
Closed	00880300003600
Closed	00880300003700
Closed	00880300003800
Closed	00880300003900
Closed	00880300004000
Closed	32053300103800
Closed	27051700408600
Closed	28050200302300
Closed	00870400000900
Closed	00870400001000
Closed	00870400001100
Closed	00870400001200
Closed	00414100000500
Closed	00414100000400
Closed	31050500100900
Closed	00870300000100
Closed	00870300000200
Closed	00870400000500
Closed	00870400000600
Closed	00870400000700
Closed	00870300004200
Closed	00870300004300
Closed	00870300004400
Closed	00870300004600
Closed	00870700000900
Closed	00870700001100
Closed	00870700000600
Closed	00870700000700
Closed	00870700000400
Closed	00419500002000
Closed	00510800000701
Closed	00510800000801
Closed	00866800021400
Closed	00866800021800
Closed	00866800022400
Closed	32061500200300

Accessory Dwelling Units

Index # - File Name: 1.0022 - Single Family Dwellings Data\_Snohomish County.pdf

Closed	30061000301100
Closed	00598100000300
Closed	00871800000800
Closed	00871800000900
Closed	00871800001000
Closed	00871800001100
Closed	00871900001400
Closed	00871900001500
Closed	00871900001600
Closed	00871900001700
Closed	00871900001900
Closed	00871900002000
Closed	00871900002100
Closed	00871900002200
Closed	00871900002300
Closed	00871900002400
Closed	00871900002500
Closed	00871900001100
Closed	00871400000100
Closed	00871400000200
Closed	00871400000300
Closed	00871400000400
Closed	00871400000500
Closed	00871400000600
Closed	00871400000700
Closed	31060700200100
Closed	31043100402100
Closed	00871100000600
Closed	29060700403100
Closed	32081200201200
Closed	27071800104900
Closed	00872000000400
Closed	00557600003601
Closed	00872000000200
Closed	00872000000600
Closed	00872000000700
Closed	00872000000800
Closed	00872000000900
Closed	00872000001000
Closed	00871900002700
Closed	00871900002800
Closed	30040800200600
Closed	30040800200700
Closed	00871800000100
Closed	00871800001700
Closed	00871800001800
Closed	00871800001900

Accessory Dwelling Units

Index # - File Name: 1.0022 - Single Family Dwellings Data\_Snohomish County.pdf

Closed	00871800002000
Closed	00871800002100
Closed	00871800002200
Closed	00871800002300
Closed	00872200000100
Closed	00872200000200
Closed	00872200000300
Closed	00872200000400
Closed	00872200000500
Closed	00872200000600
Closed	00872200000700
Closed	00872200000800
Closed	00872200000900
Closed	00872200001000
Closed	00872200001100
Closed	00872200001200
Closed	00872200001300
Closed	00872200001400
Closed	27070700301800
Closed	00872300000100
Closed	00872300000200
Closed	00872300000300
Closed	00872300000400
Closed	00872300000500
Closed	00872300000600
Closed	00872300000700
Closed	00872300000800
Closed	00872300000900
Closed	00872300001000
Closed	00590700017201
Closed	31043500400500
Closed	00590700024303
Closed	32053200205500
Closed	00874000000700
Closed	00874000000800
Closed	00874000000900
Closed	00874000000300
Closed	00891200100200
Closed	00891200100200
Closed	00891200300100
Closed	32050900203800
Closed	32050900203900
Closed	32050900204000
Closed	32050900203300
Closed	32050900203400
Closed	32050900203600
Closed	00577600400100

Accessory Dwelling Units

Index # - File Name: 1.0022 - Single Family Dwellings Data\_Snohomish County.pdf

Closed	28050200201300
Closed	31043300300200
Closed	30060700203100
Closed	00557300202200
Closed	00557300202300
Closed	28073400200200
Closed	28052600300400
Closed	00873600004200
Closed	00873600004000
Closed	00873600003700
Closed	00873600003000
Closed	00873600003100
Closed	00873600003200
Closed	00873600002700
Closed	00873600002800
Closed	00873600001800
Closed	00873600001900
Closed	00873600002300
Closed	00873600002400
Closed	00873600002500
Closed	00873600001600
Closed	00873600000900
Closed	00873600001200
Closed	00873600001300
Closed	00873600001400
Closed	00873600000700
Closed	32070900100300
Closed	00873600000400
Closed	27052600401600
Closed	31053300401200
Closed	31053300401200
Closed	00512200000300
Closed	31053300401200
Closed	32052900404000
Closed	28070700401400
Closed	00509500006304
Closed	31053300401200
Closed	31053300401200
Closed	31053300401200
Closed	31053300401200
Closed	28072800200900
Closed	31053300401200
Closed	30061400102400
Closed	30061400102500
Closed	30061400102600
Closed	31053300401200
Closed	31053300401200

Accessory Dwelling Units

Index # - File Name: 1.0022 - Single Family Dwellings Data\_Snohomish County.pdf

Closed	00537900001802
Closed	00460000005000
Closed	00394401900100
Closed	00394401900400
Closed	00394400104300
Closed	00394400204000
Closed	00557600003701
Closed	31040500202800
Closed	00872600000100
Closed	00872600000200
Closed	00872600000300
Closed	00872600000400
Closed	00872600000500
Closed	00872600000600
Closed	00872600000700
Closed	00872600000800
Closed	00872600000900
Closed	00872600001000
Closed	00872600003600
Closed	00872600003700
Closed	00872600003800
Closed	00872600003900
Closed	00872600004000
Closed	00872600004100
Closed	00872600004200
Closed	00872600004300
Closed	00872600004400
Closed	00872600004500
Closed	00872600004600
Closed	00872600004700
Closed	00872600004800
Closed	00373300601611
Closed	00373300601612
Closed	00373300601613
Closed	31041800302000
Closed	27051700304600
Closed	00441900001800
Closed	31040200301700
Closed	00568700500507
Closed	00568700500508
Closed	30062200101500
Closed	00675700001200
Closed	00394405201000
Closed	00868900000100
Closed	00868900000200
Closed	00868900000300
Closed	27051000203900

Accessory Dwelling Units

Index # - File Name: 1.0022 - Single Family Dwellings Data\_Snohomish County.pdf

Closed	00868300200100
Closed	30062600301000
Closed	00868900002500
Closed	00868900002600
Closed	29061200302300
Closed	00868300201700
Closed	00868300201200
Closed	00868300200700
Closed	00868400001700
Closed	00868400001800
Closed	00868400001900
Closed	00868400002000
Closed	00868400001300
Closed	00868400000700
Closed	29060200304200
Closed	29060200304100
Closed	00868300103200
Closed	00868000002000
Closed	29060300401500
Closed	00868300101900
Closed	29060200303400
Closed	29060200303300
Closed	29060200303500
Closed	29060200303500
Closed	00868000001800
Closed	00868000001000
Closed	00868000002300
Closed	00868000002400
Closed	00868000002500
Closed	00868000002600
Closed	00868000002700
Closed	00868000002800
Closed	00868000002900
Closed	00868000001400
Closed	00868000001500
Closed	00868000000600
Closed	00868000000700
Closed	00868000000800
Closed	00868000000100
Closed	28072900405000
Closed	28072900405100
Closed	008676000009100
Closed	00866800021700
Closed	28050200403200
Closed	30061000103200
Closed	30061000104100
Closed	32052100402000



Accessory Dwelling Units

Index # - File Name: 1.0022 - Single Family Dwellings Data\_Snohomish County.pdf

Closed	27061700302700
Closed	27061700302800
Closed	00867600008600
Closed	00867600008700
Closed	00867600008800
Closed	00867600008900
Closed	00870300003500
Closed	00870300003600
Closed	00870300003700
Closed	00870300003800
Closed	00870300003900
Closed	00870300003100
Closed	00870300003200
Closed	00870300002200
Closed	00870300002300
Closed	00870300002400
Closed	00870300002500
Closed	00870300002600
Closed	00870300001600
Closed	00870300001700
Closed	00870300001800
Closed	31043100102400
Closed	27051100306500
Closed	00597400002200
Closed	00869900002000
Closed	00869900001700
Closed	00373700401901
Closed	00869900001200
Closed	00869900001300
Closed	00869900002200
Closed	00869900002300
Closed	00869900002400
Closed	00869900002500
Closed	00869900000400
Closed	00870000008700
Closed	00870000008800
Closed	00870000008900
Closed	00869900000100
Closed	00869900000200
Closed	00870100200500
Closed	32051500300900
Closed	00870100200700
Closed	27090300200200
Closed	00870100101600
Closed	00870100101700
Closed	00870100101900
Closed	00870100102000

Accessory Dwelling Units

Index # - File Name: 1.0022 - Single Family Dwellings Data\_Snohomish County.pdf

Closed	00870100102100
Closed	00870100101000
Closed	00870100101100
Closed	00870100101200
Closed	00870100100100
Closed	00870100100600
Closed	00870100100700
Closed	00870100100400
Closed	00870000007600
Closed	00385500700602
Closed	00870000007100
Closed	00870000007200
Closed	00870000007300
Closed	00870000007400
Closed	00870000008000
Closed	00870000008100
Closed	00870000008200
Closed	00870000008300
Closed	00870000008400
Closed	00870000008500
Closed	00870000008600
Closed	00466700002200
Closed	00870000005400
Closed	00870000005500
Closed	00870000005600
Closed	00870000005700
Closed	00870000006100
Closed	00870000006200
Closed	00870000006300
Closed	00870000006400
Closed	00870000006500
Closed	00870000006600
Closed	00870000006800
Closed	00870000006900
Closed	00870000004200
Closed	00870000004300
Closed	00870000004400
Closed	00870000004500
Closed	00870000003100
Closed	00870000002400
Closed	00870000002700
Closed	00870000002800
Closed	00870000002200
Closed	00870000001500
Closed	00870000001600
Closed	00870000001700
Closed	00870000000600

Accessory Dwelling Units

Index # - File Name: 1.0022 - Single Family Dwellings Data\_Snohomish County.pdf

Closed	0087000000700
Closed	0087000000800
Closed	0087000000900
Closed	0087000001000
Closed	0087000001100
Closed	0087000001200
Closed	0087000000300
Closed	0086930000600
Closed	0087000000100
Closed	00409500005300
Closed	28063100200400
Closed	00579100002201
Closed	30040100103500
Closed	28073200403000
Closed	29062300201700
Closed	32063300303800
Closed	32040700401500
Closed	00557000001200
Closed	00403900027509
Closed	27071900401500
Closed	27071900401800
Closed	27061900301200
Closed	27102000300500
Closed	27062000101400
Closed	27051600403800
Closed	27051600404900
Closed	27051500402000
Closed	27071100401700
Closed	27071100401700
Closed	27051400303800
Closed	27091400300600
Closed	27051500100300
Closed	27051100301500
Closed	27050900401600
Closed	27051000204000
Closed	27051000405800
Closed	27061000104800
Closed	27061000105400
Closed	27090400302300
Closed	27050400403500
Closed	27060400101400
Closed	27070400300400
Closed	27070700402200
Closed	27070200104000
Closed	27070100101200
Closed	27060300300900
Closed	27070300101000

Accessory Dwelling Units

Index # - File Name: 1.0022 - Single Family Dwellings Data\_Snohomish County.pdf

Closed	00373000601103
Closed	00373001900102
Closed	27063500205400
Closed	27063100400400
Closed	27063100400600
Closed	27043100203100
Closed	27053300110500
Closed	27063400301100
Closed	27053500101000
Closed	27062900300100
Closed	27062900100500
Closed	27072900200700
Closed	27052800103600
Closed	00794600001700
Closed	27062800202100
Closed	27052400301700
Closed	27052400302200
Closed	27062200201400
Closed	27062100403400
Closed	27062500101300
Closed	27062400100800
Closed	00376400001503
Closed	00376800002400
Closed	00381400000500
Closed	00414400201200
Closed	00414400102000
Closed	00403900019308
Closed	00403800007102
Closed	00433100004300
Closed	00433100005700
Closed	00460200021600
Closed	00460200017800
Closed	00460000007700
Closed	00460100003600
Closed	00624800000300
Closed	00631900000900
Closed	00623700002400
Closed	00623700001300
Closed	00623700001700
Closed	00599900000700
Closed	00578100001800
Closed	00576800500200
Closed	00556600007800
Closed	00559600003200
Closed	00559600003300
Closed	00509500000403
Closed	00511900200802

Accessory Dwelling Units

Index # - File Name: 1.0022 - Single Family Dwellings Data\_Snohomish County.pdf

Closed	00506900000900
Closed	00473600003600
Closed	00473600003700
Closed	00473600004100
Closed	00473600004300
Closed	00473600004700
Closed	00473600004800
Closed	00473600004900
Closed	00473600005000
Closed	00492600001200
Closed	00500100000900
Closed	00512100001800
Closed	00512200001701
Closed	00512000210500
Closed	00517000001901
Closed	28060400301000
Closed	00513700008001
Closed	28083500201500
Closed	00384400001900
Closed	28053600402600
Closed	28073400200400
Closed	28073400201600
Closed	28073400203000
Closed	28053200201000
Closed	28063200100400
Closed	28093100402700
Closed	28053300102800
Closed	28073000103500
Closed	28073000200500
Closed	28073000401400
Closed	28082600100400
Closed	28082800100100
Closed	28072800104900
Closed	28072800303300
Closed	28072600102000
Closed	28072600201000
Closed	28062200400200
Closed	28072300101200
Closed	28072500400500
Closed	28061400202200
Closed	28061400303200
Closed	28061500300400
Closed	28071900300400
Closed	28071800401500
Closed	28071900400700
Closed	28061200301300
Closed	28061100400400

Accessory Dwelling Units

Index # - File Name: 1.0022 - Single Family Dwellings Data\_Snohomish County.pdf

Closed	28061100103000
Closed	28060900400100
Closed	28060300101400
Closed	28060600206600
Closed	00668900000700
Closed	00802400000200
Closed	00802400001400
Closed	00399200002200
Closed	00400500001206
Closed	00414100000501
Closed	00420500002401
Closed	00435500000200
Closed	00473300600602
Closed	00475900001100
Closed	00552400701802
Closed	00568700401207
Closed	00552300301103
Closed	00552300301104
Closed	00538000006201
Closed	00511300003400
Closed	00552300200603
Closed	00540300000500
Closed	00493900001500
Closed	00493900001600
Closed	00574200005100
Closed	00574200002000
Closed	00573900001100
Closed	00574000009700
Closed	00597400001105
Closed	00596500001400
Closed	00608100300401
Closed	00669200000100
Closed	00633800002000
Closed	00627600000400
Closed	00627600000500
Closed	00796700001300
Closed	00796700001400
Closed	00790200002500
Closed	29050200300400
Closed	29060400406200
Closed	29061000101800
Closed	29060900205700
Closed	29060900307400
Closed	29061000300400
Closed	29062700300600
Closed	29063400400800
Closed	29063500304300

Accessory Dwelling Units

Index # - File Name: 1.0022 - Single Family Dwellings Data\_Snohomish County.pdf

Closed	29062300401900
Closed	29061500202900
Closed	29062000401700
Closed	30052400100400
Closed	30042400101100
Closed	30062200102300
Closed	30062100103300
Closed	30062100103300
Closed	30072000300800
Closed	30062100201700
Closed	30072100300500
Closed	30042200101200
Closed	30061800301600
Closed	30061500302100
Closed	30041500401400
Closed	30061400101500
Closed	30051200102900
Closed	30061000101700
Closed	30080700202700
Closed	30051200403000
Closed	30051300401900
Closed	30040300203200
Closed	30060700100400
Closed	30060400400700
Closed	00493300101501
Closed	00492000105500
Closed	00491600001300
Closed	00456200000400
Closed	00442100001800
Closed	00457100003106
Closed	00457100003903
Closed	00393800001700
Closed	00393800001800
Closed	00385700400101
Closed	00394700000300
Closed	00393800000200
Closed	00393800000400
Closed	00393800000500
Closed	00393800000600
Closed	00393800000700
Closed	00393800000800
Closed	00402400001103
Closed	00591200100611
Closed	00591200100702
Closed	00591200100703
Closed	00533400002303
Closed	00611300008300

Accessory Dwelling Units

Index # - File Name: 1.0022 - Single Family Dwellings Data\_Snohomish County.pdf

Closed	00611300005800
Closed	00611300016700
Closed	00611300013600
Closed	00625700002500
Closed	00627100002600
Closed	00625200003200
Closed	00585900002700
Closed	00600900200101
Closed	00600500003600
Closed	00600500003700
Closed	00557300103500
Closed	00557300103700
Closed	00557300104000
Closed	00557300104100
Closed	00557300104600
Closed	00557300104700
Closed	00557300201800
Closed	00557300201900
Closed	00557300202700
Closed	00557300202800
Closed	00557300201600
Closed	00551500012100
Closed	00551500010700
Closed	00551500011600
Closed	00551500009100
Closed	00551500009200
Closed	00551500008800
Closed	00551500008000
Closed	00551500000300
Closed	00551500000500
Closed	00551500000600
Closed	00551400004402
Closed	00551400005401
Closed	00551400005601
Closed	00551400005900
Closed	00551400003600
Closed	00551500002000
Closed	00551500003300
Closed	00550700001000
Closed	00543800002503
Closed	00543300009500
Closed	00543300007500
Closed	00543400005600
Closed	00543800001200
Closed	00511000003200
Closed	00489000000400
Closed	00470600004500



Accessory Dwelling Units

Index # - File Name: 1.0022 - Single Family Dwellings Data\_Snohomish County.pdf

Closed	00428600003600
Closed	00400800001400
Closed	30063600201800
Closed	00385300003400
Closed	00423700000400
Closed	30063100401200
Closed	30063200402600
Closed	30073000301500
Closed	30062800300500
Closed	30062800300100
Closed	30052400402100
Closed	31052500300300
Closed	31042300404400
Closed	31052400202800
Closed	31042100200100
Closed	31052000300400
Closed	31042000200400
Closed	31051900100300
Closed	31061800301000
Closed	31051900303400
Closed	31051800401500
Closed	31041500101000
Closed	31060600301300
Closed	31040800101000
Closed	31040800201400
Closed	31040800300100
Closed	31051200401200
Closed	31041200302200
Closed	31040900302100
Closed	31041000401600
Closed	31041100301400
Closed	31050400302000
Closed	31050400302400
Closed	31040400300300
Closed	31040500400800
Closed	31050500101000
Closed	31063500202700
Closed	00384300000700
Closed	00394401004500
Closed	00381800000300
Closed	31043600101600
Closed	00379500000801
Closed	31063100100300
Closed	31063100201100
Closed	31063100301300
Closed	31053200301500
Closed	31062900301700

Accessory Dwelling Units

Index # - File Name: 1.0022 - Single Family Dwellings Data\_Snohomish County.pdf

Closed	31052600301500
Closed	31042600400500
Closed	31062800301700
Closed	00394510400900
Closed	00394510701002
Closed	00480700001701
Closed	00464600001400
Closed	00464600001500
Closed	00480700003000
Closed	00482900008300
Closed	00394403100100
Closed	00394405300101
Closed	00394405101200
Closed	00394509600600
Closed	32063200102300
Closed	32073000402000
Closed	32042800101700
Closed	32052100303200
Closed	32042600102200
Closed	32042600403400
Closed	32042700100800
Closed	32052700100500
Closed	32042000301500
Closed	32051900401900
Closed	32041400301200
Closed	32051400302300
Closed	32041400401300
Closed	32051800301600
Closed	32061000202000
Closed	32051100401200
Closed	32061100201100
Closed	32061100300700
Closed	32061000201700
Closed	32071200102200
Closed	32051300301700
Closed	32051200400500
Closed	32051300201700
Closed	32040900202500
Closed	32050700201700
Closed	32090700202400
Closed	00579100004900
Closed	00701100000200
Closed	00630700002600
Closed	32060300303100
Closed	32040400200400
Closed	32060300401500
Closed	00499100201100

Accessory Dwelling Units

Index # - File Name: 1.0022 - Single Family Dwellings Data\_Snohomish County.pdf

Closed	00499100202000
Closed	00537400000500
Closed	00609700000300
Closed	00609700000400
Closed	00609700000500
Closed	00585200006002
Closed	00585200009100
Closed	00579100004302
Closed	00537400002900
Closed	00492400201100
Closed	00485300001700
Closed	00483000004900
Closed	00489700200702
Closed	00489700201800
Closed	00489700202100
Closed	00848500001100
Closed	00848500000100
Closed	30052700208000
Closed	31053500200200
Closed	00557500000802
Closed	00557500000702
Closed	28071500301400
Closed	30072800200900
Closed	27051400203000
Closed	30061700400600
Closed	27050300401500
Closed	30050600301800
Closed	32091100400700
Closed	28083000301900
Closed	28071200400500
Closed	00611300001100
Closed	27080300300700
Closed	00374100200402
Closed	29060200101100
Closed	30062100202900
Closed	30062400300900
Closed	30062400302100
Closed	30062400301700
Closed	31062800201300
Closed	31062800201400
Closed	32053000101300
Closed	29061500303500
Closed	00385300003101
Closed	31050100102700
Closed	00844300000600
Closed	00844800000500
Closed	31043500400600

Accessory Dwelling Units

Index # - File Name: 1.0022 - Single Family Dwellings Data\_Snohomish County.pdf

Closed	27052300203000
Closed	30060300401400
Closed	00394405101201
Closed	00394405101202
Closed	29061700301900
Closed	32091200302100
Closed	27070200400300
Closed	32063300401800
Closed	00490100007900
Closed	00490100008000
Closed	00490100008200
Closed	00490100008300
Closed	00490100008400
Closed	30062400400300
Closed	00590700000302
Closed	00842800008700
Closed	00842800008800
Closed	00842800008900
Closed	00842800009000
Closed	00842800000100
Closed	00842800000200
Closed	00842800000300
Closed	00842800000400
Closed	00842800000500
Closed	00842800000600
Closed	00842800000700
Closed	00842800000800
Closed	00842800000900
Closed	00842800001000
Closed	00842800001100
Closed	00842800001200
Closed	00842800001300
Closed	00842800001400
Closed	00842800001500
Closed	00842800001600
Closed	00842800001700
Closed	00842800001800
Closed	00842800001900
Closed	00842800002000
Closed	30060100203900
Closed	30063600100600
Closed	00490000000900
Closed	32090500401500
Closed	00466800000800
Closed	29061900403500
Closed	00400800001100
Closed	00400800001200

Accessory Dwelling Units

Index # - File Name: 1.0022 - Single Family Dwellings Data\_Snohomish County.pdf

Closed	00394405200900
Closed	30063200203900
Closed	00841700003200
Closed	00841700003300
Closed	00840300000800
Closed	00493000000600
Closed	29061900105300
Closed	29063600101100
Closed	32052300300500
Closed	00604900001904
Closed	30060800103700
Closed	29073400400400
Closed	00839100000200
Closed	00473300201102
Closed	32090700100200
Closed	28062300201300
Closed	32071900100400
Closed	00836500002600
Closed	00836500003300
Closed	00836500004600
Closed	00836500004700
Closed	00836500004800
Closed	00836500005700
Closed	00836500001800
Closed	00836500000400
Closed	00836500000600
Closed	00837600011200
Closed	00837600005300
Closed	00837600005400
Closed	00837600005500
Closed	00837600005600
Closed	00837600005700
Closed	00837600005800
Closed	00837600005900
Closed	00837600004900
Closed	00837600004700
Closed	00589600002200
Closed	00589600010200
Closed	00589600010300
Closed	00589600007300
Closed	00490100001600
Closed	32063200404000
Closed	32063200304300
Closed	32063500201200
Closed	32043600201200
Closed	00383700000300
Closed	00383800001000

Accessory Dwelling Units

Index # - File Name: 1.0022 - Single Family Dwellings Data\_Snohomish County.pdf

Closed	00589600013900
Closed	28073000303000
Closed	32062000100800
Closed	32062000100800
Closed	00529100000100
Closed	00577600301200
Closed	00492800000100
Closed	00621500004900
Closed	31041000201000
Closed	00489100005200
Closed	27053400302500
Closed	27071100101000
Closed	30042300303200
Closed	30042300400900
Closed	00823300013800
Closed	00823300008600
Closed	00823300008700
Closed	00823300008800
Closed	00823300013200
Closed	00823300013300
Closed	00823300013400
Closed	00823300013500
Closed	00823300012400
Closed	00823300012500
Closed	00823300012600
Closed	00823300012700
Closed	00823300008400
Closed	00823300008000
Closed	00823300007600
Closed	00823300007700
Closed	00823300006100
Closed	00823300004400
Closed	00823300005900
Closed	00823300005300
Closed	00823300005400
Closed	00823300002900
Closed	00823300003100
Closed	00823300003200
Closed	00823300002700
Closed	00823300002500
Closed	00823300003600
Closed	00823300003800
Closed	00818500000500
Closed	32041400302600
Closed	27062700301300
Closed	00821200000500
Closed	29063600200400

Accessory Dwelling Units

Index # - File Name: 1.0022 - Single Family Dwellings Data\_Snohomish County.pdf

Closed	00823300000100
Closed	32043400200100
Closed	00823300002200
Closed	00823300002300
Closed	00823300001700
Closed	00823300001800
Closed	30041600301000
Closed	30041600301100
Closed	00621500002000
Closed	31043200200300
Closed	32041000402500
Closed	00570600100501
Closed	00490100006900
Closed	27062300300800
Closed	00441900002200
Closed	00825700000700
Closed	31052400202900
Closed	30041500400200
Closed	31042700103200
Closed	00394510601400
Closed	28093100301800
Closed	32053300303000
Closed	00492800001900
Closed	00464300000800
Closed	00828800004300
Closed	00828800004400
Closed	00466900001600
Closed	29060100202700
Closed	29060400402600
Closed	00831300001100
Closed	27062800201100
Closed	00837600003400
Closed	00837600003500
Closed	00837600003600
Closed	00837600003700
Closed	00837600003800
Closed	00837600003900
Closed	00837600004000
Closed	00837600000100
Closed	00837600000200
Closed	29050300401600
Closed	00604800001203
Closed	00604800001204
Closed	00836800000900
Closed	00836000000700
Closed	00836000000800
Closed	00836000000900

Accessory Dwelling Units

Index # - File Name: 1.0022 - Single Family Dwellings Data\_Snohomish County.pdf

Closed	00836000001000
Closed	00836000001100
Closed	00836000001200
Closed	00818900000100
Closed	00803600000500
Closed	29052600103100
Closed	32051100400600
Closed	00593300000502
Closed	31043100102000
Closed	00864000002200
Closed	00864000002300
Closed	00864000002400
Closed	00864000002500
Closed	00864000002600
Closed	00864000002700
Closed	00864000002800
Closed	00864000002900
Closed	00551500003000
Closed	00480401707801
Closed	29060500204000
Closed	29060500204100
Closed	29060500204200
Closed	29060500204300
Closed	27051300200800
Closed	27051300200700
Closed	27051300200600
Closed	00863400000700
Closed	00863400000800
Closed	00863400000900
Closed	00863400001000
Closed	00863400001100
Closed	00863400001200
Closed	00863200000200
Closed	00867600002600
Closed	00867600002700
Closed	00867600002800
Closed	00867600002900
Closed	00867600003000
Closed	00867600003100
Closed	00867600003200
Closed	00867600003300
Closed	00867600003400
Closed	00867600001300
Closed	00867600001400
Closed	00867600001500
Closed	00867600000800
Closed	00867600000900



Accessory Dwelling Units

Index # - File Name: 1.0022 - Single Family Dwellings Data\_Snohomish County.pdf

Closed	00867600001000
Closed	00867600000500
Closed	30061200200300
Closed	30061200200500
Closed	00394406400803
Closed	00866900000700
Closed	00866900000300
Closed	00440100001803
Closed	28072600403100
Closed	00867000006500
Closed	00867000006600
Closed	00867000006700
Closed	00867000006800
Closed	00867000007100
Closed	00867000007200
Closed	00867000007500
Closed	00867000007600
Closed	00867000007700
Closed	00867000007800
Closed	00867000007900
Closed	00867000008000
Closed	00867000008100
Closed	00867000008200
Closed	00867000008300
Closed	00867000008400
Closed	00867000008500
Closed	00867000008600
Closed	00867000008700
Closed	28072100102000
Closed	31060500303300
Closed	00867000002500
Closed	00867000002600
Closed	00867000002700
Closed	00867000002800
Closed	00867000002900
Closed	00867000003100
Closed	00867000003200
Closed	00867000003300
Closed	00867000003400
Closed	00867000003500
Closed	00867000003600
Closed	00867000003700
Closed	00867000003800
Closed	00867000003900
Closed	00867000004000
Closed	00867000004100
Closed	00867000004200

Accessory Dwelling Units

Index # - File Name: 1.0022 - Single Family Dwellings Data\_Snohomish County.pdf

Closed	00867000004300
Closed	00867000004400
Closed	00867000004700
Closed	00867000004900
Closed	00867000005000
Closed	00867000005100
Closed	00867000005200
Closed	00867000005300
Closed	00867000005600
Closed	00867000005700
Closed	31041300200400
Closed	31060500303000
Closed	00394510401000
Closed	00590700007802
Closed	29061400101000
Closed	00394400603900
Closed	32041600401800
Closed	32051800302000
Closed	30040400102400
Closed	29072800302300
Closed	29072800302400
Closed	27071800104000
Closed	00505100000400
Closed	30061400401200
Closed	31043500405300
Closed	30063600302200
Closed	30060300400500
Closed	00551500000400
Closed	30063600302000
Closed	00511900402003
Closed	00551500002600
Closed	00860500001800
Closed	00860500001900
Closed	00860500001500
Closed	00860500001300
Closed	00860500001100
Closed	28072600202800
Closed	31060600402500
Closed	00860500003100
Closed	00860500003200
Closed	00860500003300
Closed	00860100000400
Closed	27073200300200
Closed	00860500002100
Closed	00860500002200
Closed	00860500002300
Closed	00860500002500

Accessory Dwelling Units

Index # - File Name: 1.0022 - Single Family Dwellings Data\_Snohomish County.pdf

Closed	00860500002600
Closed	00860500002700
Closed	00860500002800
Closed	00445400101708
Closed	00860100000700
Closed	28071500301200
Closed	32063100103200
Closed	00394402001200
Closed	00858200000200
Closed	00858200001000
Closed	00858200001200
Closed	00858200001300
Closed	00858400001200
Closed	00385300003200
Closed	00385300003600
Closed	29061000101000
Closed	31043100201200
Closed	31060900201000
Closed	00960003901500
Closed	00860500000100
Closed	00543800004406
Closed	29060900203700
Closed	27051100201800
Closed	00892153100100
Closed	00892152900300
Closed	00892152700500
Closed	00892152300700
Closed	00892152100900
Closed	00892151901100
Closed	00892151701300
Closed	00892151501500
Closed	00892151301700
Closed	00892150901900
Closed	00892150702100
Closed	00892150502300
Closed	32062100100800
Closed	00579100004200
Closed	00473300003405
Closed	00480000008400
Closed	00862100000800
Closed	00862100000900
Closed	28060300303300
Closed	32042900102900
Closed	00862500000400
Closed	00863000000100
Closed	28071900200600
Closed	28050200305000

Accessory Dwelling Units

Index # - File Name: 1.0022 - Single Family Dwellings Data\_Snohomish County.pdf

Closed	32062100201600
Closed	00862400000200
Closed	28072100202200
Closed	00568700500408
Closed	29062300401300
Closed	30060500301600
Closed	30060500301700
Closed	30060500301800
Closed	30060500301900
Closed	30060500302000
Closed	00480000006100
Closed	28073000303300
Closed	30060500302200
Closed	30060500301300
Closed	30060500301400
Closed	00960011800100
Closed	00403800008103
Closed	30060500401600
Closed	00585700000100
Closed	00852800001200
Closed	00853300002000
Closed	00464300000100
Closed	00850200000400
Closed	00850200000200
Closed	29053600100700
Closed	30060800202100
Closed	30060800202900
Closed	30060800203200
Closed	00849400000300
Closed	00489100010900
Closed	00849400000600
Closed	00849400000700
Closed	00849400000800
Closed	00849400000100
Closed	29060100202400
Closed	29060100202900
Closed	30060800201900
Closed	00374800002200
Closed	32071100400700
Closed	30060400201000
Closed	28073400404100
Closed	00543800003701
Closed	32041400302200
Closed	30063500400300
Closed	00394405101701
Closed	31052900301100
Closed	00556600007600

Accessory Dwelling Units

Index # - File Name: 1.0022 - Single Family Dwellings Data\_Snohomish County.pdf

Closed	28061400400400
Closed	30060200300100
Closed	00853600003600
Closed	27073100401200
Closed	00853300003000
Closed	00853600000600
Closed	00853600001200
Closed	00853600001300
Closed	00853600001700
Closed	00853600002700
Closed	29062000210600
Closed	29060200100600
Closed	27052600100700
Closed	31040500401200
Closed	00960001502000
Closed	00399900100406
Closed	28061000203500
Closed	32052900400500
Closed	27070200301600
Closed	00590700003200
Closed	00585200005500
Closed	00492900000700
Closed	00517000005501
Closed	00480401705402
Closed	28050100301400
Closed	00513100000900
Closed	00394401803400
Closed	29071800201400
Closed	32041400200400
Closed	28060400401300
Closed	00490400000100
Closed	00529800002000
Closed	00403900016007
Closed	00533400001703
Closed	27051400203100
Closed	00489100002202
Closed	27090500202700
Closed	31050900201400
Closed	00960003014600
Closed	30070500202300
Closed	30062100200200
Closed	00853600003000
Closed	00853600000200
Closed	00853600000300
Closed	31052600200600
Closed	31060700200600
Closed	00409500001402

Accessory Dwelling Units

Index # - File Name: 1.0022 - Single Family Dwellings Data\_Snohomish County.pdf

Closed	00409500001501
Closed	27062700300500
Closed	00621900000301
Closed	32040500202500
Closed	30063300403300
Closed	00394403200400
Closed	32071100400700
Closed	00394400303300
Closed	00394400303600
Closed	28081900301000
Closed	00849600000900
Closed	00849600001000
Closed	30041500401700
Closed	00394401807000
Closed	30060800201400
Closed	00394401400006
Closed	00853300003400
Closed	00853300003500
Closed	30060500401100
Closed	27072900401400
Closed	32050500201400
Closed	32053200205100
Closed	00862100001400
Closed	00862100001800
Closed	00862100000200
Closed	00892150102500
Closed	29061000201200
Closed	27081100200600
Closed	00554300003600
Closed	31063500301200
Closed	00557600003201
Closed	31060900201400
Closed	31060900201200
Closed	30061400102200
Closed	31043100201100
Closed	32040400103200
Closed	00858200001400
Closed	00533300000100
Closed	00533300000200
Closed	29060900402200
Closed	00590700005301
Closed	00860500002000
Closed	00431400100203
Closed	31043500405200
Closed	32040800301800
Closed	32041000401500
Closed	30042400100700

Accessory Dwelling Units

Index # - File Name: 1.0022 - Single Family Dwellings Data\_Snohomish County.pdf

Closed	32100800201100
Closed	00492000302100
Closed	32041600401700
Closed	30060500402500
Closed	30073000300500
Closed	00866900001700
Closed	28072000202200
Closed	00863200000300
Closed	27061800303100
Closed	29060500204400
Closed	28072300100400
Closed	00440200000801
Closed	31043100102100
Closed	31052400102200
Closed	00401000003600
Closed	00401100014900
Closed	32040700100700
Closed	31042200306900
Closed	30042400100600
Closed	28060600103100
Closed	00594900001200
Closed	29052600103200
Closed	29061500104200
Closed	30063200203800
Closed	27062200301900
Closed	30062700201400
Closed	30062700201500
Closed	31063100200600
Closed	00384500005100
Closed	27061700202800
Closed	27061700202600
Closed	00832300001600
Closed	00831300001300
Closed	00830700001500
Closed	32042500300400
Closed	28060900203400
Closed	28071800101600
Closed	32052300100200
Closed	27062700402700
Closed	00409100000202
Closed	00824500000300
Closed	29061400102700
Closed	30042300401200
Closed	30042300401300
Closed	32040500301400
Closed	00597400000110
Closed	00823300002100

Accessory Dwelling Units

Index # - File Name: 1.0022 - Single Family Dwellings Data\_Snohomish County.pdf

Closed	28060800101700
Closed	30071900102400
Closed	27053600401000
Closed	27062100401100
Closed	00818500000600
Closed	31051900303800
Closed	30063500301000
Closed	32063300300800
Closed	00823300004100
Closed	00823300013100
Closed	28072900302100
Closed	30042300401600
Closed	30042300401100
Closed	30040300301600
Closed	32071000201100
Closed	27090800300200
Closed	28050200401000
Closed	28050200401400
Closed	28050200400500
Closed	28050200401500
Closed	28073200303500
Closed	28073200303400
Closed	28073200303300
Closed	28073200303200
Closed	28073200303100
Closed	28073200403700
Closed	28073200403400
Closed	28073200403200
Closed	28073200403600
Closed	28073200403500
Closed	28083500307000
Closed	32040300301900
Closed	00383800003100
Closed	00383800003200
Closed	00413900001600
Closed	00413900001700
Closed	32063200404700
Closed	32053300103200
Closed	32053300103100
Closed	32063400303100
Closed	00490100002000
Closed	00587200001100
Closed	00589600010400
Closed	00589600000900
Closed	00589600001400
Closed	00589600001500
Closed	00589600001700



Accessory Dwelling Units

Index # - File Name: 1.0022 - Single Family Dwellings Data\_Snohomish County.pdf

Closed	0058960000600
Closed	00384500005200
Closed	31052500301600
Closed	00836500001200
Closed	00836500006000
Closed	00836500005200
Closed	00836500003400
Closed	00836500003700
Closed	00836500003800
Closed	00498700000400
Closed	28082100401700
Closed	31043000400600
Closed	00457100001501
Closed	00841700003700
Closed	27071800401400
Closed	00842300004300
Closed	00842300004400
Closed	00627300008300
Closed	00373003000107
Closed	00842600000800
Closed	31062000202400
Closed	29061000400200
Closed	32053000100900
Closed	00844300000900
Closed	00844300001000
Closed	00844300000200
Closed	00844300000300
Closed	00844800000400
Closed	32100800301800
Closed	32053000101400
Closed	00604700000400
Closed	30062400301600
Closed	30062400402200
Closed	30062500201000
Closed	30062400301000
Closed	30062300400900
Closed	30062300401000
Closed	32090800401900
Closed	30062400302000
Closed	29062300101800
Closed	28071500301300
Closed	27051000103000
Closed	00394400302400
Closed	00394400302800
Closed	00394400305300
Closed	32051200100600
Closed	30051200101200

Accessory Dwelling Units

Index # - File Name: 1.0022 - Single Family Dwellings Data\_Snohomish County.pdf

Closed	29062300101200
Closed	00847800000200
Closed	00490900004400
Closed	00537400000400
Closed	00607300000500
Closed	00498800101300
Closed	00494600301003
Closed	32060300401400
Closed	32060300302000
Closed	00721200000200
Closed	32080200301000
Closed	32080100302400
Closed	00701100000500
Closed	00621500004500
Closed	32090700203000
Closed	32050700201800
Closed	32050400201100
Closed	32040900301600
Closed	32070800300400
Closed	32090700401300
Closed	32091200302500
Closed	32071200102200
Closed	32041000302700
Closed	32041000101300
Closed	32081100400500
Closed	32051100400300
Closed	32041100200300
Closed	32051800401900
Closed	32062000200600
Closed	32062000200700
Closed	32062000202400
Closed	32042300300500
Closed	32052800301800
Closed	32062800201800
Closed	00394509000400
Closed	00394406600702
Closed	00394406600200
Closed	00394406600300
Closed	00394405201500
Closed	00482900001800
Closed	00483000001400
Closed	00464600002100
Closed	00394510600500
Closed	00406300005400
Closed	00417900001600
Closed	00409000003400
Closed	31052600402900

Accessory Dwelling Units

Index # - File Name: 1.0022 - Single Family Dwellings Data\_Snohomish County.pdf

Closed	00384300000400
Closed	00384300002200
Closed	31043500404500
Closed	31063300301900
Closed	31063300302100
Closed	31053300401000
Closed	31063300300500
Closed	31063300301200
Closed	31050500100800
Closed	31060600200300
Closed	31050500301300
Closed	31040500301300
Closed	31050400201500
Closed	31050400202000
Closed	31040200301400
Closed	00792700000600
Closed	31040300201700
Closed	31041000102400
Closed	31041000301800
Closed	31051300403000
Closed	31051300403100
Closed	31060800101800
Closed	31060800400500
Closed	31040800203200
Closed	31060600301400
Closed	31040800100700
Closed	31041400300200
Closed	31041800201700
Closed	31051800101200
Closed	31051900302900
Closed	31042000100900
Closed	31042200303100
Closed	30042400102200
Closed	30062500100400
Closed	30062700200900
Closed	30072900401200
Closed	27070200101400
Closed	30052900200600
Closed	30072800300300
Closed	30073200300300
Closed	30053100202000
Closed	00406400002300
Closed	00401100005400
Closed	00377100001200
Closed	00401000003800
Closed	00400800002000
Closed	00401000000100

Accessory Dwelling Units

Index # - File Name: 1.0022 - Single Family Dwellings Data\_Snohomish County.pdf

Closed	00429100001700
Closed	00426900000400
Closed	00444800001700
Closed	00444800001900
Closed	00429900001900
Closed	00478500000900
Closed	00459900300300
Closed	00489100005800
Closed	00489000005500
Closed	00489100005500
Closed	00511000010100
Closed	00520200000600
Closed	00828700000900
Closed	00551500004100
Closed	00551500004900
Closed	00551500005700
Closed	00551400003800
Closed	00551400003900
Closed	00551400004000
Closed	00551400000500
Closed	00551400000600
Closed	00551400002400
Closed	00551500009900
Closed	00551500010600
Closed	00551500011700
Closed	00551500011800
Closed	00551500011900
Closed	00557300201700
Closed	00557300203300
Closed	00557300203500
Closed	00557300202000
Closed	00557300202100
Closed	00557300202500
Closed	00557300103200
Closed	00557300104300
Closed	00557300104500
Closed	00557300103800
Closed	00557300102400
Closed	00600500003300
Closed	00590400001700
Closed	00590700016500
Closed	00590700005302
Closed	00579800000106
Closed	00627300007700
Closed	00622300001800
Closed	00622300002100
Closed	00622300000300

Accessory Dwelling Units

Index # - File Name: 1.0022 - Single Family Dwellings Data\_Snohomish County.pdf

Closed	00622300000700
Closed	00631600007800
Closed	00736500001000
Closed	00631600004200
Closed	00611300018500
Closed	00611300011100
Closed	00647500001600
Closed	00658400000100
Closed	00528600000300
Closed	00516700008600
Closed	00516700008900
Closed	00516700009000
Closed	00516700009100
Closed	00533400001200
Closed	00591200100500
Closed	00607100001501
Closed	00607100002701
Closed	00607100002800
Closed	00440200001802
Closed	00441900001600
Closed	00471400003100
Closed	00492000106300
Closed	00516700001500
Closed	00516700006200
Closed	30060400101000
Closed	30060400102400
Closed	30060600100300
Closed	30040300302700
Closed	30040300400600
Closed	30060200301600
Closed	30041400401300
Closed	30051200301400
Closed	30061000201900
Closed	30052000300800
Closed	30062100300300
Closed	30052000400200
Closed	30062000302200
Closed	30072000202100
Closed	30062200102100
Closed	30052400200500
Closed	30052500201900
Closed	29062600102600
Closed	29052600101800
Closed	29063500101000
Closed	29053500101200
Closed	29053500102000
Closed	29063200100400

Accessory Dwelling Units

Index # - File Name: 1.0022 - Single Family Dwellings Data\_Snohomish County.pdf

Closed	29062700101200
Closed	29070500300100
Closed	00805000000300
Closed	00597400000108
Closed	00570600100302
Closed	00570700200303
Closed	00574200002400
Closed	00540300000900
Closed	00540300001100
Closed	00552300300701
Closed	00552300401002
Closed	00562800001700
Closed	00560000000400
Closed	00568900001002
Closed	00475900001000
Closed	00469000001100
Closed	00420600000200
Closed	00420400001700
Closed	00400700001900
Closed	00403800013300
Closed	00404400001700
Closed	00396000002100
Closed	00802400001300
Closed	00802400005100
Closed	00802400000300
Closed	00802400000100
Closed	28050200104100
Closed	28060200103200
Closed	28061000201900
Closed	28051100302300
Closed	28070600300100
Closed	28051200101000
Closed	28061400202000
Closed	28061700200700
Closed	28061500201200
Closed	28061500101700
Closed	28061600403300
Closed	28062500402400
Closed	28062400402300
Closed	28062400303600
Closed	28072700201100
Closed	28072800201100
Closed	28072900404900
Closed	28093100400800
Closed	28073400304600
Closed	00374000002400
Closed	00374900000100

Accessory Dwelling Units

Index # - File Name: 1.0022 - Single Family Dwellings Data\_Snohomish County.pdf

Closed	00374900007100
Closed	00382400000500
Closed	00382400001000
Closed	00382400001100
Closed	00382400001200
Closed	28073500301200
Closed	00526100503900
Closed	00512200005700
Closed	00511900300701
Closed	00512000203400
Closed	00491400300404
Closed	00556700001300
Closed	00556600010700
Closed	00576800502600
Closed	00577600200700
Closed	00577700504000
Closed	00577700603800
Closed	00609600001300
Closed	00617300200403
Closed	00617300201001
Closed	00623700001700
Closed	00623700002600
Closed	00630500000100
Closed	00630500000200
Closed	00638800000300
Closed	00460000007500
Closed	00461001000200
Closed	00433100005900
Closed	00433200000400
Closed	00433200000500
Closed	00421100000100
Closed	00403800006602
Closed	00403800009301
Closed	00409500000903
Closed	00374100600403
Closed	00400400001900
Closed	00373101200601
Closed	00373700402901
Closed	00373701001901
Closed	27052700200900
Closed	27052700205100
Closed	27062500100200
Closed	27062600201000
Closed	27062200400300
Closed	27052800107900
Closed	27062700402800
Closed	27062700402900

Accessory Dwelling Units

Index # - File Name: 1.0022 - Single Family Dwellings Data\_Snohomish County.pdf

Closed	27072900300700
Closed	27062800401700
Closed	27063300300600
Closed	27063300102000
Closed	27053300100100
Closed	27063100400600
Closed	27053600301200
Closed	27053600301700
Closed	27053600401300
Closed	00372800802601
Closed	00373000100107
Closed	00373000100201
Closed	27050300302700
Closed	27080100300500
Closed	27050200303300
Closed	27070800300400
Closed	27090300300500
Closed	27061000104800
Closed	27051000401300
Closed	31043000400500
Closed	27051000100400
Closed	27051100302700
Closed	27061000404200
Closed	27051500105300
Closed	27071100401000
Closed	27061200400100
Closed	27051500400400
Closed	27061700401400
Closed	27051900101100
Closed	27051900101700
Closed	27071900402200
Closed	32042400401000
Closed	32063200404100
Closed	00869300000300
Closed	00869300000400
Closed	00869300000500
Closed	00869300000100
Closed	00869300000200
Closed	00621500003500
Closed	00621500004800
Closed	00870000007000
Closed	00870000005800
Closed	00870000005900
Closed	00870000006000
Closed	00870000007500
Closed	00870000007700
Closed	00870000007800



Accessory Dwelling Units

Index # - File Name: 1.0022 - Single Family Dwellings Data\_Snohomish County.pdf

Closed	0087000007900
Closed	00870100100500
Closed	00870100200100
Closed	00870100200300
Closed	00870100200400
Closed	00869900002600
Closed	00869900002700
Closed	00869900002800
Closed	00869900001400
Closed	00869900001500
Closed	00869900001600
Closed	00869900000600
Closed	31063000200300
Closed	00869900002100
Closed	32051200400400
Closed	00489100003000
Closed	27071000200300
Closed	31052500301700
Closed	00867600002000
Closed	00866800018600
Closed	00867600008400
Closed	00867600005900
Closed	00867600006000
Closed	27061800303400
Closed	00866800018800
Closed	00866800019000
Closed	00866800019200
Closed	00866800020000
Closed	00866800020200
Closed	00866800020400
Closed	00866800020500
Closed	00866800020700
Closed	00866800020900
Closed	00866800021300
Closed	00866800021500
Closed	00866800022300
Closed	00868000003000
Closed	00868000003400
Closed	00868000003500
Closed	29060200303600
Closed	29060200303800
Closed	29060300401400
Closed	29060300402500
Closed	00868400000800
Closed	00868400001100
Closed	00868400001200
Closed	00868400001600

Accessory Dwelling Units

Index # - File Name: 1.0022 - Single Family Dwellings Data\_Snohomish County.pdf

Closed	28060800100900
Closed	31042000400800
Closed	30062000202000
Closed	31041800302100
Closed	31042400200400
Closed	31053300401200
Closed	31053300401200
Closed	31053300401200
Closed	31053300401200
Closed	31053300401200
Closed	31053300401200
Closed	31053300401200
Closed	31053300401200
Closed	31053300401200
Closed	31053300401200
Closed	31053300401200
Closed	31053300401200
Closed	31053300401200
Closed	00537800002502
Closed	00537800002503
Closed	32040600201100
Closed	29062300101700
Closed	30062700101300
Closed	00394403100600
Closed	00597400000205
Closed	32090700301000
Closed	31043100402000
Closed	30040800200500
Closed	00529800000900
Closed	30063300301700
Closed	00866800021600
Closed	00893400002800
Closed	31043100401400
Closed	00479903401100
Closed	28050300104800
Closed	00866800018700
Closed	00866800018900
Closed	00866800019100
Closed	00866800019300
Closed	00866800020100
Closed	00866800020300
Closed	00866800020600
Closed	00866800020800
Closed	00866800021000
Closed	00866800021200
Closed	00893400003100
Closed	00893400003200
Closed	00893400003300

Accessory Dwelling Units

Index # - File Name: 1.0022 - Single Family Dwellings Data\_Snohomish County.pdf

Closed	00893400003400
Closed	00893400003500
Closed	00893400003600
Closed	00893400003700
Closed	00893400003900
Closed	00893400004000
Closed	00893400004100
Closed	00893400004200
Closed	00893400004300
Closed	00893400004400
Closed	00893400004500
Closed	00893400004600
Closed	00893400004700
Closed	00893400004800
Closed	00893400004900
Closed	00893400005000
Closed	00893400005100
Closed	00893400005200
Closed	00893400005300
Closed	00893400005400
Closed	00893400005500
Closed	00893400005600
Closed	32053300403000
Closed	00893400000100
Closed	00893400000200
Closed	00893400000300
Closed	00893400000400
Closed	00893400000500
Closed	00893400000600
Closed	00893400000700
Closed	00893400000800
Closed	00893400000900
Closed	00893400001000
Closed	00893400001100
Closed	00893400001200
Closed	00893400001300
Closed	00893400001400
Closed	00893400001700
Closed	00893400001800
Closed	00893400001900
Closed	00893400002000
Closed	00893400002100
Closed	00893400002200
Closed	00893400002300
Closed	00893400002400
Closed	00893400002500
Closed	00893400002600

Accessory Dwelling Units

Index # - File Name: 1.0022 - Single Family Dwellings Data\_Snohomish County.pdf

Closed	00880300004100
Closed	00880300004200
Closed	00880300004300
Closed	00880300004400
Closed	00394510001200
Closed	29051100104500
Closed	29061200301600
Closed	00879800000100
Closed	00879800002500
Closed	00879800002600
Closed	00879800002700
Closed	00879800002800
Closed	00879800002900
Closed	00879800003000
Closed	00879800003100
Closed	00879800001500
Closed	00879800001600
Closed	00879800001700
Closed	00879800001800
Closed	00879800001900
Closed	00879800002000
Closed	00879800000500
Closed	00879800000700
Closed	28053600105500
Closed	00403800014708
Closed	00464600001300
Closed	32052100204000
Closed	32052100204100
Closed	27071800401000
Closed	29061000100400
Closed	00880400000800
Closed	00880400001500
Closed	00880400001600
Closed	00880400001700
Closed	00880300005700
Closed	00880400000200
Closed	00880400000300
Closed	00880400000400
Closed	00880400000500
Closed	00880400000600
Closed	00881200000300
Closed	30061200300100
Closed	29061400200600
Closed	29051400104200
Closed	29051400104300
Closed	29051400104400
Closed	32092700100800

Accessory Dwelling Units

Index # - File Name: 1.0022 - Single Family Dwellings Data\_Snohomish County.pdf

Closed	32050900202900
Closed	31052500402400
Closed	30072800201600
Closed	29072100400600
Closed	29062300201300
Closed	29061400302900
Closed	29061400303000
Closed	29062300200500
Closed	29062300200600
Closed	29062300200700
Closed	00878900001200
Closed	00878900000500
Closed	00579100004706
Closed	00579100004707
Closed	00579100003300
Closed	28062500402800
Closed	28072500302300
Closed	28072500302400
Closed	29062000301800
Closed	00479800202000
Closed	00879300002400
Closed	00879300002500
Closed	00879300002000
Closed	00879300001100
Closed	00879300001200
Closed	00879300001300
Closed	00879300000900
Closed	00879300000700
Closed	32040800301700
Closed	00879300000300
Closed	29062300201900
Closed	00879300003400
Closed	00879300003800
Closed	00879300003000
Closed	00879300003100
Closed	00877300000200
Closed	31040400401300
Closed	31051900104500
Closed	29061000400900
Closed	00877100000600
Closed	00877100000800
Closed	00877100000900
Closed	00877100000100
Closed	00373002700106
Closed	32040200301500
Closed	00577900000200
Closed	00590700012100

Accessory Dwelling Units

Index # - File Name: 1.0022 - Single Family Dwellings Data\_Snohomish County.pdf

Closed	00876800000800
Closed	00876800000600
Closed	00876800000300
Closed	00876200000900
Closed	00876200000400
Closed	00876200000600
Closed	30051200403500
Closed	00876300000100
Closed	32091100101200
Closed	00607100001801
Closed	27090500401300
Closed	27062200201000
Closed	00877700000400
Closed	00877700000500
Closed	00403800011100
Closed	27051400107500
Closed	00877700000700
Closed	00874600000800
Closed	00466900001700
Closed	00874900001800
Closed	00874900001600
Closed	00874900001200
Closed	00874900001300
Closed	00874900001000
Closed	00874900000800
Closed	00874900000200
Closed	29061500303800
Closed	31041000400100
Closed	00440200000501
Closed	30061400303300
Closed	00590700019103
Closed	30040100103900
Closed	00885200001300
Closed	00885200001400
Closed	00885200000900
Closed	00885200001000
Closed	00885200000500
Closed	00885100001200
Closed	00885100001300
Closed	00885100001400
Closed	00885100001500
Closed	00885100000200
Closed	00885100000300
Closed	00885100000400
Closed	00885100000500
Closed	00885100000600
Closed	00885100000700

Accessory Dwelling Units

Index # - File Name: 1.0022 - Single Family Dwellings Data\_Snohomish County.pdf

Closed	00885100000800
Closed	00885100000900
Closed	00885100001000
Closed	31053100100100
Closed	00403800012701
Closed	27070700301900
Closed	27062900101700
Closed	00557300104200
Closed	00884400000200
Closed	00884400000300
Closed	00884400000400
Closed	00884400000500
Closed	00884300001000
Closed	00884300001300
Closed	00884300001400
Closed	00884300000400
Closed	00884300000500
Closed	00884300000600
Closed	00884300000700
Closed	00884300000800
Closed	00884300000200
Closed	00884300001800
Closed	00884300001900
Closed	00884300002000
Closed	00884300002100
Closed	00884300002200
Closed	00884300002400
Closed	00884300002500
Closed	00884300002600
Closed	00884300002700
Closed	00884300002800
Closed	00884300002900
Closed	00884300003000
Closed	00884300003100
Closed	00884300003200
Closed	00884300003300
Closed	00884300003400
Closed	00884300003500
Closed	00884300003600
Closed	30062600100700
Closed	30062600100300
Closed	00884200000600
Closed	00884100002400
Closed	00526100534100
Closed	00482900000600
Closed	00884200000300
Closed	00884200000400

Accessory Dwelling Units

Index # - File Name: 1.0022 - Single Family Dwellings Data\_Snohomish County.pdf

Closed	31060400101200
Closed	28060900100300
Closed	00587400000803
Closed	27063400403000
Closed	30052100107200
Closed	32080200301400
Closed	00491600000500
Closed	00883500000100
Closed	32050900400400
Closed	00883800003100
Closed	00883800002900
Closed	00883800002000
Closed	00883800001400
Closed	00883800001500
Closed	00883800001700
Closed	00883800001800
Closed	00883800000800
Closed	00883800000900
Closed	00883800001000
Closed	00604800001108
Closed	00394401803200
Closed	00590700027602
Closed	00590700027603
Closed	00883500002500
Closed	00883500002200
Closed	00883500001700
Closed	00883500001800
Closed	00883500001900
Closed	00883500002000
Closed	00883500001400
Closed	00389400200700
Closed	00883500001000
Closed	00883500001100
Closed	00883500001200
Closed	27062500102000
Closed	00409500001600
Closed	31041100201000
Closed	00568700500305
Closed	28072900304100
Closed	00883000001300
Closed	32052100304900
Closed	00882700004000
Closed	00882700004100
Closed	00882700004200
Closed	00882700004300
Closed	30070100200600
Closed	00882700004800



Accessory Dwelling Units

Index # - File Name: 1.0022 - Single Family Dwellings Data\_Snohomish County.pdf

Closed	00882700004900
Closed	00882700005000
Closed	00882700005100
Closed	00882700005200
Closed	00882700005300
Closed	00882700005400
Closed	00882700005600
Closed	00882700003500
Closed	00882700003600
Closed	00882700003700
Closed	00882700003800
Closed	00882700002200
Closed	00882700002000
Closed	00882700002400
Closed	00882700002500
Closed	00882700002600
Closed	00882700002700
Closed	00882700002800
Closed	00882700003000
Closed	00882700003100
Closed	00882700003200
Closed	00882700001700
Closed	00882700001300
Closed	00882700001000
Closed	00882700000700
Closed	00882800302600
Closed	00882700000400
Closed	00882700000500
Closed	00882700000100
Closed	00882800302200
Closed	00882800302300
Closed	00882800302400
Closed	00882800301700
Closed	00882800301400
Closed	00882800301200
Closed	00882800205300
Closed	00882800205400
Closed	00882800204900
Closed	00882800205000
Closed	00882800205100
Closed	00882800300700
Closed	00882800300800
Closed	00882800300900
Closed	00882800204300
Closed	00882800204400
Closed	00882800204000
Closed	00882800204100

Accessory Dwelling Units

Index # - File Name: 1.0022 - Single Family Dwellings Data\_Snohomish County.pdf

Closed	27081800201100
Closed	00882200001100
Closed	00882800203700
Closed	00882800203800
Closed	00882200000500
Closed	00882200000600
Closed	27062800301600
Closed	30050900410100
Closed	00882000004200
Closed	00882000002500
Closed	00881200000500
Closed	00881200000600
Closed	29071900101400
Closed	00372700801002
Closed	00372700801002
Closed	00372700801002
Closed	00372700801002
Closed	00372700801002
Closed	30061900302300
Closed	30061900302700
Closed	00882000002100
Closed	00414300001502
Closed	00888300002600
Closed	00888300002700
Closed	00888300002800
Closed	00888300002900
Closed	00888300003000
Closed	00888300003100
Closed	00598100000400
Closed	00888300002200
Closed	00888300002300
Closed	00888300002400
Closed	00888300000100
Closed	28072000202500
Closed	29062000404100
Closed	29062000404600
Closed	29062000404700
Closed	31052500102700
Closed	00490400002000
Closed	32063200304600
Closed	00896200000100
Closed	00896200000200
Closed	00896200000300
Closed	00896200000400
Closed	00896200000500
Closed	00896200000600
Closed	00617300201102

Accessory Dwelling Units

Index # - File Name: 1.0022 - Single Family Dwellings Data\_Snohomish County.pdf

Closed	30042400202100
Closed	00887200000200
Closed	00480401604002
Closed	27051500404200
Closed	00597600000400
Closed	00888300000400
Closed	00888300000500
Closed	00888300000600
Closed	00888300000700
Closed	00888300000800
Closed	00888300000900
Closed	00888300001000
Closed	00888300001100
Closed	00888300001200
Closed	00888300001300
Closed	00888300001400
Closed	00888300001500
Closed	00888300001600
Closed	00888300001700
Closed	00888300001800
Closed	00888300001900
Closed	00896200003100
Closed	00896200003200
Closed	00896200003300
Closed	00896200003400
Closed	00896200003500
Closed	00896200003600
Closed	00896200003700
Closed	00896200003800
Closed	00896200004000
Closed	00896200004100
Closed	00896200004200
Closed	00896200004300
Closed	00896200004500
Closed	00896200004600
Closed	00896200004700
Closed	00896200004800
Closed	00896200004800
Closed	00896200004900
Closed	00896200005000
Closed	00896200005100
Closed	00896200005200
Closed	00896200005300
Closed	00896200005400
Closed	00896200005500
Closed	00896200005600
Closed	00896200005700

Accessory Dwelling Units

Index # - File Name: 1.0022 - Single Family Dwellings Data\_Snohomish County.pdf

Closed	00896200005800
Closed	00896200005900
Closed	00896200006000
Closed	00896200006100
Closed	00896200006200
Closed	00896200006300
Closed	00896200006400
Closed	00896200006500
Closed	00896200006600
Closed	00896200006700
Closed	00896200006800
Closed	00896200006900
Closed	00896200007000
Closed	00896200007100
Closed	00896200007200
Closed	00896200007300
Closed	00896200007400
Closed	00896200007500
Closed	00896200007600
Closed	00896200007700
Closed	00896200007800
Closed	00896200007900
Closed	00896200008000
Closed	00896200008100
Closed	00896200008200
Closed	00896200008300
Closed	00896200008400
Closed	00896200008500
Closed	00896200008600
Closed	00896200008700
Closed	00896200008800
Closed	00896200008900
Closed	00896200009000
Closed	00896200009100
Closed	00896200009200
Closed	00896200009300
Closed	00896200009400
Closed	00896200009500
Closed	00480401602102
Closed	00886900012100
Closed	00886900011900
Closed	00886900012300
Closed	00960014205500
Closed	00960014205600
Closed	00886900010400
Closed	00886900010500
Closed	00886900010600

Accessory Dwelling Units

Index # - File Name: 1.0022 - Single Family Dwellings Data\_Snohomish County.pdf

Closed	00886900010700
Closed	00886900010800
Closed	00886900011000
Closed	00886900011400
Closed	00886900011500
Closed	00886900008700
Closed	00886900008800
Closed	00886900008900
Closed	00886900009000
Closed	00886900009100
Closed	00886900008300
Closed	00886900008400
Closed	00886900008500
Closed	00886900010200
Closed	00886900009300
Closed	00886900009400
Closed	00886900009500
Closed	00886900009600
Closed	00886900009700
Closed	00886900009800
Closed	00886900009900
Closed	00960014206500
Closed	00960014206600
Closed	00960014206700
Closed	00960014206800
Closed	00960014206900
Closed	00960014207000
Closed	00960014207100
Closed	00960014207200
Closed	00960014207400
Closed	00960014205800
Closed	00960014206100
Closed	00960014206300
Closed	00960014207800
Closed	00960014208900
Closed	00960014209100
Closed	00960014209200
Closed	00960014209400
Closed	00960014209700
Closed	00960014209800
Closed	00960014209900
Closed	00960014210000
Closed	00960014210200
Closed	00960014210400
Closed	00960014210500
Closed	00960014210600
Closed	00960014210800

Accessory Dwelling Units

Index # - File Name: 1.0022 - Single Family Dwellings Data\_Snohomish County.pdf

Closed	00960014208400
Closed	00960014208500
Closed	00427100003000
Closed	00886900007900
Closed	00886900005200
Closed	00886900005300
Closed	00886900007000
Closed	00886900007100
Closed	00886900007200
Closed	00886900007300
Closed	00886900007400
Closed	00886900007500
Closed	00886900007600
Closed	00886900004400
Closed	00886900004500
Closed	00886900004600
Closed	00886900004900
Closed	00886900005600
Closed	00886900005700
Closed	00886900005800
Closed	00886900005900
Closed	00886900006000
Closed	00886900006100
Closed	00886900006200
Closed	00886900006300
Closed	00886900006400
Closed	00886900006500
Closed	00886900006600
Closed	00886900006700
Closed	00886900012500
Closed	00886900012600
Closed	00886900012700
Closed	31052000103900
Closed	31052000104000
Closed	00960014200100
Closed	00960014200200
Closed	00960014200300
Closed	00960014200400
Closed	00960014200500
Closed	00960014200600
Closed	00960014200700
Closed	00960014200800
Closed	00960014200900
Closed	00960014201000
Closed	00960014201100
Closed	00960014201200
Closed	00960014201300

Accessory Dwelling Units

Index # - File Name: 1.0022 - Single Family Dwellings Data\_Snohomish County.pdf

Closed	00960014201400
Closed	00960014201500
Closed	00960014201600
Closed	00960014201700
Closed	00960014201800
Closed	00960014201900
Closed	00960014202000
Closed	00960014202100
Closed	00960014202200
Closed	00960014202300
Closed	00960014202400
Closed	00960014202500
Closed	00960014202600
Closed	00960014202800
Closed	00960014202900
Closed	00960014203000
Closed	00960014203100
Closed	00960014203200
Closed	00960014203300
Closed	00960014203400
Closed	00960014203600
Closed	00960014203700
Closed	00960014203800
Closed	00960014203900
Closed	00960014204000
Closed	00960014204100
Closed	00960014204200
Closed	00960014204300
Closed	00960014204400
Closed	00960014204500
Closed	00960014204600
Closed	00886900001000
Closed	00886900001100
Closed	00886900001200
Closed	00886900001300
Closed	00886900001500
Closed	00886900000800
Closed	00403800000814
Closed	00886900003500
Closed	00886900003600
Closed	00886900003700
Closed	00886900003400
Closed	00886900003900
Closed	00886900001800
Closed	00886900001900
Closed	00886900002000
Closed	00886900002100

Accessory Dwelling Units

Index # - File Name: 1.0022 - Single Family Dwellings Data\_Snohomish County.pdf

Closed	00886900002200
Closed	00886900002300
Closed	00886900002400
Closed	00886900002500
Closed	00886900002600
Closed	00886900002700
Closed	00886900002800
Closed	00886900002900
Closed	00886900003000
Closed	00886900003100
Closed	00886900003200
Closed	00467100010500
Closed	27052300200300
Closed	00582500500400
Closed	00478400000601
Closed	27051600402700
Closed	00489800000202
Closed	00489800000501
Closed	00489100006500
Closed	00373002101405
Closed	00373002101403
Closed	00886900000100
Closed	00886900000300
Closed	00886900000400
Closed	00886900000500
Closed	00886900000600
Closed	00886400003800
Closed	00886400003900
Closed	00886400004000
Closed	00886400004100
Closed	00886400004200
Closed	00886400004300
Closed	00886400004400
Closed	00886400004500
Closed	00886400004600
Closed	00886400004700
Closed	32063400400300
Closed	30061900302900
Closed	00394403300200
Closed	28060800102100
Closed	28060800102000
Closed	00886400000400
Closed	00886400000500
Closed	00886400000600
Closed	00886400000700
Closed	00886400000800
Closed	00886400000900



Accessory Dwelling Units

Index # - File Name: 1.0022 - Single Family Dwellings Data\_Snohomish County.pdf

Closed	00886400001000
Closed	00886400001100
Closed	00886400001200
Closed	00886400001300
Closed	00886400001400
Closed	00886400001500
Closed	00886400001600
Closed	00886400001700
Closed	00886400001800
Closed	00886400001900
Closed	00886400002000
Closed	00886400002100
Closed	00886400002200
Closed	00886400002300
Closed	00886400002400
Closed	00886400002500
Closed	00886400002600
Closed	00886400002700
Closed	00886400002800
Closed	00886300000800
Closed	00886300001200
Closed	00886300001300
Closed	00886300001400
Closed	00886300001500
Closed	00886300001600
Closed	00886300001700
Closed	00886000001500
Closed	00886000001600
Closed	30060100301400
Closed	30060100301500
Closed	00886000000500
Closed	00886000000700
Closed	00886000000800
Closed	00886000000900
Closed	00886000001000
Closed	00886000001100
Closed	00886000001200
Closed	00886000001300
Closed	00885500005200
Closed	00885500005300
Closed	00885500005600
Closed	00885500004800
Closed	00885500004900
Closed	00568700500104
Closed	00568700500105
Closed	00885300000800
Closed	00885500001100

Accessory Dwelling Units

Index # - File Name: 1.0022 - Single Family Dwellings Data\_Snohomish County.pdf

Closed	00885500001200
Closed	00885500001300
Closed	00885500001400
Closed	00885700001500
Closed	00885700001600
Closed	00885700001700
Closed	00885700001800
Closed	00885700001900
Closed	00885700002000
Closed	00885700002100
Closed	00885700000700
Closed	00885700000800
Closed	00885700000900
Closed	00885700001000
Closed	00885700001100
Closed	00885600000100
Closed	00885600000200
Closed	00885600000300
Closed	00885600000400
Closed	31043100101000
Closed	29062000103500
Closed	00879300004100
Closed	30070700200400
Closed	30061900302600
Closed	00885800000900
Closed	00885800000600
Closed	00885800000400
Closed	00609600001400
Closed	27052700203700
Closed	27052700207100
Closed	27052700207200
Closed	00431400100510
Closed	00569000005104
Closed	00372800801204
Closed	00372800801206
Closed	00890100000500
Closed	00890100000700
Closed	00890100000800
Closed	00890100000900
Closed	00890100000200
Closed	29060400405700
Closed	29060400405800
Closed	29060700404000
Closed	32060900102300
Closed	00890500000100
Closed	00890500000200
Closed	00890500000300

Accessory Dwelling Units

Index # - File Name: 1.0022 - Single Family Dwellings Data\_Snohomish County.pdf

Closed	0089050000400
Closed	0089050000500
Closed	0089050000600
Closed	0089050000700
Closed	0089050000800
Closed	0089050000900
Closed	0089050001000
Closed	0089050001100
Closed	0089050001200
Closed	0089050001300
Closed	00890100001800
Closed	00890100002000
Closed	00551400002300
Closed	30062600300600
Closed	00890800000100
Closed	00891000000100
Closed	00891100000500
Closed	00891100000600
Closed	00891100000700
Closed	00891100000800
Closed	00891100000900
Closed	00891100001000
Closed	00891100001100
Closed	00891100001200
Closed	00891100001300
Closed	00891100001400
Closed	00890800000200
Closed	00890800000300
Closed	00890800000400
Closed	00890800000500
Closed	00890800000600
Closed	00890800000700
Closed	00890800000800
Closed	00890800001300
Closed	00890800001400
Closed	00890800001500
Closed	00890800001600
Closed	00890800001700
Closed	00890800001800
Closed	00890800001900
Closed	00890800002000
Closed	00890800002100
Closed	00890800002200
Closed	00890800002300
Closed	00890800002400
Closed	00890800002500
Closed	00890800002600

Accessory Dwelling Units

Index # - File Name: 1.0022 - Single Family Dwellings Data\_Snohomish County.pdf

Closed	00890800002700
Closed	00890800002800
Closed	00890800002900
Closed	00890800003000
Closed	00890800003100
Closed	00890800003200
Closed	00890800003300
Closed	00890800003400
Closed	00890800003500
Closed	00890800003600
Closed	00890800003700
Closed	00890800003800
Closed	00890800003900
Closed	00890800004000
Closed	00890800004100
Closed	00890800004200
Closed	00890800004300
Closed	00890800004400
Closed	00890800004500
Closed	00890800004600
Closed	00890800004700
Closed	00890800004800
Closed	00890800004900
Closed	00890800005000
Closed	00890800005100
Closed	00890800005200
Closed	00890800005300
Closed	00890800005400
Closed	00890800005500
Closed	00890800005600
Closed	00890800005700
Closed	00890800005800
Closed	00890800005900
Closed	00891000000200
Closed	00891000000300
Closed	00891000000400
Closed	00891000000600
Closed	00891000000700
Closed	00891000000800
Closed	00891000000900
Closed	00891000001000
Closed	00891000001100
Closed	00891000001200
Closed	00891000001300
Closed	00891000001400
Closed	00891000001500
Closed	00891000001600

Accessory Dwelling Units

Index # - File Name: 1.0022 - Single Family Dwellings Data\_Snohomish County.pdf

Closed	0089110000200
Closed	00891100002300
Closed	00891100002400
Closed	32092300300600
Closed	00891100003300
Closed	00891100003400
Closed	00891100003500
Closed	00891100003700
Closed	00891100004900
Closed	00891100005000
Closed	00891100005100
Closed	00891100005200
Closed	00891100005300
Closed	00891100005400
Closed	00891100005500
Closed	00891100005600
Closed	00891100005700
Closed	00891100005800
Closed	00891100005900
Closed	00891100006000
Closed	00891100006100
Closed	00891100006200
Closed	00891100006300
Closed	00891100006400
Closed	00891100007200
Closed	00891100007300
Closed	00891100007400
Closed	00891100007500
Closed	00891100007600
Closed	00891100007700
Closed	00891100007800
Closed	00891100007900
Closed	00891100008000
Closed	00891100008100
Closed	00891100008200
Closed	00891100008300
Closed	00891100008400
Closed	00891100008500
Closed	00891100008600
Closed	00891100008700
Closed	00891100008800
Closed	00891100008900
Closed	00891100009700
Closed	00891100009800
Closed	00891100009900
Closed	00891100010000
Closed	00891100010100

Accessory Dwelling Units

Index # - File Name: 1.0022 - Single Family Dwellings Data\_Snohomish County.pdf

Closed	00891100010200
Closed	00891100010300
Closed	00891100010400
Closed	00891100010500
Closed	00891100010600
Closed	00891100010700
Closed	00891100010800
Closed	00891100010900
Closed	00891100011000
Closed	00891100011100
Closed	00891100004000
Closed	00891100004100
Closed	00891100004200
Closed	00891100004300
Closed	00891100004400
Closed	00891100004500
Closed	00891100004600
Closed	00891100004700
Closed	00891100006600
Closed	00891100009500
Closed	00891100011400
Closed	00891100011500
Closed	00891100011600
Closed	00891100011700
Closed	00891100012700
Closed	00891100013000
Closed	00891100014600
Closed	00891100014900
Closed	00891100015100
Closed	00891100015300
Closed	00891100015400
Closed	00891100015500
Closed	00891100015600
Closed	00891100015700
Closed	00891100016700
Closed	00891100016800
Closed	00891100016900
Closed	00891100017000
Closed	00891100016200
Closed	00891100017500
Closed	28062300402200
Closed	30062800401800
Closed	00889800000200
Closed	00889800000300
Closed	00889800000400
Closed	00889800001500
Closed	00889800001600

Accessory Dwelling Units

Index # - File Name: 1.0022 - Single Family Dwellings Data\_Snohomish County.pdf

Closed	00709700004600
Closed	00512000100400
Closed	28061300401400
Closed	28061300401500
Closed	28061300401600
Closed	30062000401500
Closed	00394402300800
Closed	00889000004700
Closed	00889000004800
Closed	00889000004900
Closed	00889000005000
Closed	00889000005100
Closed	00889000005200
Closed	00889000005300
Closed	00889000005400
Closed	00889000005500
Closed	00889000005600
Closed	00889000005700
Closed	00889000005800
Closed	00889000005900
Closed	00889000006000
Closed	00889000006100
Closed	00889000006200
Closed	00889000006300
Closed	00889000006400
Closed	00889000006500
Closed	00889000006600
Closed	00889000006700
Closed	00889000006800
Closed	00889000006900
Closed	00889000007000
Closed	00889000007100
Closed	00889000007200
Closed	00889000007300
Closed	00889000007400
Closed	00889000007500
Closed	00888900000500
Closed	00888900000600
Closed	00888900000700
Closed	00888900000800
Closed	00888900000900
Closed	00888900001000
Closed	00401000010900
Closed	29050200102500
Closed	00394406600704
Closed	31042700305400
Closed	00889300000100

Accessory Dwelling Units

Index # - File Name: 1.0022 - Single Family Dwellings Data\_Snohomish County.pdf

Closed	00889300000300
Closed	00889300000400
Closed	00889300000500
Closed	00889300000600
Closed	00889300000700
Closed	00889300000800
Closed	00889300000900
Closed	28073000202500
Closed	31063100200400
Closed	00890800001000
Closed	00889200000100
Closed	00889200000200
Closed	00889200000300
Closed	00889200000400
Closed	00889200000500
Closed	00889200000600
Closed	00889200000700
Closed	00889200000800
Closed	00889200000900
Closed	00889200001000
Closed	00889200001100
Closed	00889200001200
Closed	00889200001300
Closed	00889200001400
Closed	00889200001500
Closed	00889200001600
Closed	00889200001700
Closed	00889200001800
Closed	00889200001900
Closed	00889200002000
Closed	00889200002100
Closed	00889200002200
Closed	00889200002300
Closed	00889200002400
Closed	00889200002500
Closed	00889200002600
Closed	00889200002700
Closed	00889200002800
Closed	00889200002900
Closed	00889200003000
Closed	00889200003100
Closed	00889200003200
Closed	00889200003300
Closed	00889200003400
Closed	00889200003500
Closed	00889200003600
Closed	00889200003700



Accessory Dwelling Units

Index # - File Name: 1.0022 - Single Family Dwellings Data\_Snohomish County.pdf

Closed	00889200003800
Closed	00889200003900
Closed	00889200004000
Closed	00889200004100
Closed	00889200004200
Closed	00889200004300
Closed	00889200004400
Closed	00889200004500
Closed	00889200004600
Closed	00889200004700
Closed	00889200004800
Closed	00889200004900
Closed	00889200005000
Closed	00889200005100
Closed	00889200005200
Closed	00889200005300
Closed	32053300202800
Closed	00887400000100
Closed	00887400000200
Closed	00887400000300
Closed	00887400000400
Closed	00887400000500
Closed	00887400000600
Closed	00887400000700
Closed	00887400000800
Closed	00887400000900
Closed	00887400001100
Closed	00887400001200
Closed	27072900401300
Closed	00888700000100
Closed	00888700000200
Closed	00888700000300
Closed	00888700000400
Closed	00888700000500
Closed	00888700000600
Closed	00888700000700
Closed	00888700000800
Closed	00888700000900
Closed	00888700001000
Closed	00888700001100
Closed	00888700001200
Closed	00888700001300
Closed	00888700001400
Closed	00888700001600
Closed	00888700001700
Closed	00888700001800
Closed	00888700001900

Accessory Dwelling Units

Index # - File Name: 1.0022 - Single Family Dwellings Data\_Snohomish County.pdf

Closed	00888700002000
Closed	00888700002100
Closed	00888700002200
Closed	00888700002300
Closed	00888700002400
Closed	27051000400300
Closed	30042300401400
Closed	30040400202600
Closed	00490500001900
Closed	00889000000100
Closed	00889000000200
Closed	00889000000300
Closed	00889000000400
Closed	00889000000500
Closed	00889000000600
Closed	00889000000700
Closed	00889000000800
Closed	00889000000900
Closed	00889000001000
Closed	00889000001100
Closed	00889000001200
Closed	00889000001300
Closed	00889000001400
Closed	00889000001500
Closed	00889000001600
Closed	00889000001700
Closed	00889000001800
Closed	00889000001900
Closed	00889000002000
Closed	00889000002100
Closed	00889000002200
Closed	00889000002300
Closed	00889000002400
Closed	00889000002500
Closed	00889000002600
Closed	00889000002700
Closed	00889000002800
Closed	00889000002900
Closed	00889000003000
Closed	00889000003100
Closed	00889000003200
Closed	00889000003300
Closed	00889000003400
Closed	00889000003500
Closed	00889000003600
Closed	00889000003700
Closed	00889000003800

Accessory Dwelling Units

Index # - File Name: 1.0022 - Single Family Dwellings Data\_Snohomish County.pdf

Closed	00889000003900
Closed	00889000004000
Closed	00889000004100
Closed	00889000007700
Closed	00889000007800
Closed	00889000007900
Closed	00889000008000
Closed	00889000008100
Closed	00889000008200
Closed	00889000008300
Closed	00889000008400
Closed	00889000008500
Closed	00889000008600
Closed	00889000008700
Closed	00889000008800
Closed	00889000008900
Closed	00889000009000
Closed	00889000009100
Closed	00889000009200
Closed	00889000009300
Closed	00889000009400
Closed	00889000009500
Closed	00889000009600
Closed	00889000009700
Closed	00889000009800
Closed	00889000009900
Closed	00889000010000
Closed	00889000010100
Closed	00889000010200
Closed	00889000010300
Closed	00889000010400
Closed	00889000010500
Closed	00889000010600
Closed	00889000010700
Closed	00889000010800
Closed	00889000010900
Closed	00889000011000
Closed	00889000011100
Closed	00889000011200
Closed	00889000011300
Closed	00889000011400
Closed	00889000011500
Closed	00889000011600
Closed	00889000011700
Closed	00889000011800
Closed	00889000011900
Closed	00889000012000

Accessory Dwelling Units

Index # - File Name: 1.0022 - Single Family Dwellings Data\_Snohomish County.pdf

Closed	00889000012100
Closed	00889000012200
Closed	00889000012300
Closed	00889000012400
Closed	00889000012500
Closed	00889000012600
Closed	00889000012700
Closed	00889000012800
Closed	00889000012900
Closed	00889000013000
Closed	00889000013100
Closed	00889000013200
Closed	00889000013300
Closed	00889000013500
Closed	00889000013600
Closed	00889000013700
Closed	00889000013800
Closed	00889000013900
Closed	00889000014000
Closed	00889000014100
Closed	00889000014200
Closed	00889000014300
Closed	00889000014400
Closed	00889000014500
Closed	00889000014600
Closed	00889000014700
Closed	00889000014800
Closed	00889000014900
Closed	00889000015000
Closed	00889000015200
Closed	00889000015300
Closed	00888900000100
Closed	00888900000200
Closed	00573800001800
Closed	00573900000100
Closed	27063200302800
Closed	27063200302700
Closed	32080200300100
Closed	00891800007100
Closed	27062800203500
Closed	27062800203600
Closed	27062800203700
Closed	30061100101500
Closed	00394401703100
Closed	31063000302200
Closed	28073300200900
Closed	00892900000200

Accessory Dwelling Units

Index # - File Name: 1.0022 - Single Family Dwellings Data\_Snohomish County.pdf

Closed	00892900000300
Closed	00892900000400
Closed	00892900000500
Closed	00892900000600
Closed	00892900000700
Closed	00892900000800
Closed	00892900000900
Closed	00892900001000
Closed	00892900001100
Closed	00892900001200
Closed	00892900001300
Closed	00892900001500
Closed	00892900001600
Closed	00892900001700
Closed	00892900001800
Closed	31063000100900
Closed	00892800000100
Closed	00892800000200
Closed	00892800000300
Closed	00892800000400
Closed	00892800000500
Closed	00892800000600
Closed	00892800000700
Closed	00892800000800
Closed	00892800000900
Closed	00892800001000
Closed	00892800001100
Closed	00892800001200
Closed	00892800001300
Closed	00892800001400
Closed	00892800001500
Closed	00892800001600
Closed	00892800001700
Closed	00892800001800
Closed	00892800001900
Closed	00892800002000
Closed	00892800002100
Closed	00892800002200
Closed	00892800002300
Closed	00892800002400
Closed	00892800002500
Closed	00892800002600
Closed	00892800002700
Closed	00892800002800
Closed	00892800002900
Closed	00895800000100
Closed	00568700400807

Accessory Dwelling Units

Index # - File Name: 1.0022 - Single Family Dwellings Data\_Snohomish County.pdf

Closed	31052600102100
Closed	00893000000400
Closed	00893000000500
Closed	00893000000600
Closed	00893000000700
Closed	00893000000800
Closed	00893000000900
Closed	27060400101500
Closed	00401000003700
Closed	00538000005704
Closed	00538000005705
Closed	00538000005706
Closed	00538000005901
Closed	00893300000100
Closed	00893300000200
Closed	00893300000300
Closed	00893300000400
Closed	00893300000500
Closed	00893300000600
Closed	00893300000800
Closed	00893300000900
Closed	00893300001000
Closed	00893300001100
Closed	00382400001300
Closed	28070300300900
Closed	27090500104200
Closed	00574000006600
Closed	00551500002100
Closed	00599200001800
Closed	00373002700107
Closed	00373002700108
Closed	00373002700109
Closed	27073100401100
Closed	30063300401100
Closed	00893200000100
Closed	00893200000200
Closed	00893200000300
Closed	00893200000400
Closed	00893200000500
Closed	00893200001400
Closed	00893200000800
Closed	00893200000900
Closed	00893200001000
Closed	00893200001100
Closed	00893200004500
Closed	00893200004600
Closed	00893200004700

Accessory Dwelling Units

Index # - File Name: 1.0022 - Single Family Dwellings Data\_Snohomish County.pdf

Closed	00893200004800
Closed	00893200005000
Closed	00893200005100
Closed	00893200005200
Closed	00893200005300
Closed	00893200005400
Closed	00893200005500
Closed	00893200005600
Closed	00893200005700
Closed	00893200005800
Closed	00893200006000
Closed	31052400401400
Closed	00594000002201
Closed	00893700000300
Closed	00893700000400
Closed	00893700000500
Closed	00394404508300
Closed	31063000302500
Closed	32053300103500
Closed	28083000302600
Closed	00895800001100
Closed	28062300102800
Closed	31043500402400
Closed	30042100101800
Closed	00394510000200
Closed	00897500000700
Closed	00490100002500
Closed	00894400000100
Closed	00894400000200
Closed	00894400000300
Closed	00894400000400
Closed	00894400000500
Closed	00960005302300
Closed	00480200101802
Closed	00894400001000
Closed	00894400001200
Closed	00894400001300
Closed	00894400002400
Closed	00894400002000
Closed	00894400003500
Closed	00894400004000
Closed	00894400004100
Closed	00894400004200
Closed	00894400004300
Closed	00894400001700
Closed	00894400001800
Closed	29061100300800

Accessory Dwelling Units

Index # - File Name: 1.0022 - Single Family Dwellings Data\_Snohomish County.pdf

Closed	00794600002700
Closed	28053200104200
Closed	27063000201900
Closed	00520200004800
Closed	00894800000400
Closed	00894800000500
Closed	00894800000700
Closed	00894800001000
Closed	00894800001100
Closed	00894800001200
Closed	00894900000100
Closed	00894900000300
Closed	00894900000500
Closed	00894900000600
Closed	00894900000700
Closed	00894900001000
Closed	00894900001100
Closed	00894900001200
Closed	00894900002000
Closed	00894900002100
Closed	00894900002200
Closed	00894900001500
Closed	00894900001600
Closed	00894900001800
Closed	00493300900605
Closed	00493300900606
Closed	00493300900607
Closed	31063000302600
Closed	00891500000100
Closed	00466600010200
Closed	00891500000200
Closed	00891500000300
Closed	00891500000400
Closed	00891500000500
Closed	00891500000600
Closed	00891500000700
Closed	00891500000800
Closed	00891500000900
Closed	00891500001000
Closed	00891500001100
Closed	00891500001200
Closed	00891500001300
Closed	00891500001400
Closed	00891500001500
Closed	00891500001600
Closed	00891500001700
Closed	00891500001800



Accessory Dwelling Units

Index # - File Name: 1.0022 - Single Family Dwellings Data\_Snohomish County.pdf

Closed	00891500001900
Closed	00891500002000
Closed	00891500002100
Closed	00891500002200
Closed	00891500002300
Closed	00891500002400
Closed	00891500002500
Closed	00891500002600
Closed	00891500002700
Closed	00891500002800
Closed	00891500002900
Closed	00891500003000
Closed	00891500003100
Closed	00891500003200
Closed	00891500003300
Closed	00891500003400
Closed	00891500003500
Closed	00891500003600
Closed	00891500003700
Closed	00891500003800
Closed	00891500003900
Closed	00891500004000
Closed	00891500004100
Closed	00891500004200
Closed	00891500004300
Closed	00891500004400
Closed	00891500004500
Closed	00891500004600
Closed	00891500004700
Closed	00891500004800
Closed	00891500004900
Closed	00891500005000
Closed	00891500005100
Closed	00891500005200
Closed	00891500005300
Closed	00891500005400
Closed	00891500005500
Closed	00891500005600
Closed	00891500005700
Closed	00891500005800
Closed	00891500005900
Closed	00891500006000
Closed	00891500006100
Closed	00891500006200
Closed	00891500006300
Closed	00891500006400
Closed	00891500006500

Accessory Dwelling Units

Index # - File Name: 1.0022 - Single Family Dwellings Data\_Snohomish County.pdf

Closed	00891500006600
Closed	00891500006700
Closed	00891500006800
Closed	00891500006900
Closed	00891500007000
Closed	00891500007100
Closed	00891500007200
Closed	00891500007300
Closed	00891500007400
Closed	00891100015900
Closed	27053500400800
Closed	00890900000100
Closed	00891800005100
Closed	00891800005200
Closed	00890900000200
Closed	00890900000300
Closed	00890900000400
Closed	00890900000500
Closed	00890900000600
Closed	00890900000700
Closed	00890900000800
Closed	00890900000900
Closed	00890900001000
Closed	00890900001100
Closed	00890900001200
Closed	00890900001300
Closed	00890900001400
Closed	00890900001600
Closed	00890900001700
Closed	00890900001800
Closed	00890900001900
Closed	00890900002000
Closed	00890900002100
Closed	00890900002300
Closed	00890900002400
Closed	00890900002500
Closed	00890900002700
Closed	00890900002800
Closed	00890900002900
Closed	00890900003000
Closed	00890900003100
Closed	00890900003400
Closed	00890900003500
Closed	00891500007700
Closed	00891500007800
Closed	00891500007900
Closed	00891500008000

Accessory Dwelling Units

Index # - File Name: 1.0022 - Single Family Dwellings Data\_Snohomish County.pdf

Closed	0089150008100
Closed	0089150008200
Closed	0089150008400
Closed	0089150008500
Closed	0089150008600
Closed	0089150008700
Closed	0089150008800
Closed	0089150008900
Closed	0089150009000
Closed	0089150009100
Closed	0089150009200
Closed	0089150009300
Closed	0089150009400
Closed	0089150009500
Closed	0089150009600
Closed	0089150009700
Closed	0089150009800
Closed	0089150009900
Closed	0089150010000
Closed	0089150010100
Closed	0089150010200
Closed	0089150010300
Closed	0089150010400
Closed	0089150010500
Closed	0089150010600
Closed	0089150010700
Closed	0089150010800
Closed	0089150010900
Closed	0089150011000
Closed	0089150011100
Closed	0089150011200
Closed	0089150011300
Closed	0089150011400
Closed	0089150011500
Closed	0089150011600
Closed	0089150011700
Closed	0089150011800
Closed	0089150011900
Closed	0089150012000
Closed	0089150012100
Closed	0089150012200
Closed	0089150012300
Closed	0089150012400
Closed	0089150012500
Closed	0089150012600
Closed	0089150012700
Closed	0089150012800

Accessory Dwelling Units

Index # - File Name: 1.0022 - Single Family Dwellings Data\_Snohomish County.pdf

Closed	00891500012900
Closed	00891500008300
Closed	00891800005300
Closed	00891800005400
Closed	00890900006000
Closed	32053100403800
Closed	32053100403900
Closed	00891800001800
Closed	00891800001900
Closed	00891800002000
Closed	00891800002100
Closed	00891800002200
Closed	00891800002300
Closed	00891800002400
Closed	00891800002500
Closed	00891800002600
Closed	00891800002700
Closed	00891800002800
Closed	00891800002900
Closed	00891800003000
Closed	00891800003100
Closed	00891800003200
Closed	00891800003300
Closed	00891800003400
Closed	00891800003500
Closed	00891800003600
Closed	00891800003700
Closed	00891800003800
Closed	00891800003900
Closed	00891800004000
Closed	00891800004100
Closed	00891800004200
Closed	00891800004300
Closed	00891800004400
Closed	00891800004500
Closed	00891800004600
Closed	00891800004700
Closed	00891800004800
Closed	00891800004900
Closed	00891700000800
Closed	00891700000900
Closed	00891700001000
Closed	31042700305300
Closed	00891700000200
Closed	00891700000300
Closed	00891700000400
Closed	00891800005500

Accessory Dwelling Units

Index # - File Name: 1.0022 - Single Family Dwellings Data\_Snohomish County.pdf

Closed	00891800007800
Closed	00891800007900
Closed	00891800008000
Closed	00891800008100
Closed	00891800008200
Closed	00891800008300
Closed	00891800008400
Closed	00891800008500
Closed	00891800008600
Closed	00891800008700
Closed	00891800008800
Closed	00891800008900
Closed	00891800009000
Closed	00891800009100
Closed	00891800009200
Closed	00891800009300
Closed	00891800009400
Closed	00891800009500
Closed	00891800009600
Closed	00891800009700
Closed	00891800009800
Closed	00891800009900
Closed	00891800001500
Closed	00891800006700
Closed	00891800006900
Closed	30070600302200
Closed	00892000000100
Closed	00892000000300
Closed	00892000000400
Closed	00892000000500
Closed	00892000000600
Closed	00892000000700
Closed	00892000000800
Closed	00892000000900
Closed	00892000001000
Closed	28073000203300
Closed	28073000202400
Closed	28073000202600
Closed	28073000202900
Closed	28073000203000
Closed	28073000203100
Closed	30051500307000
Closed	30051500307100
Closed	30051500307200
Closed	00373100700608
Closed	00373100700609
Closed	00420500001800

Accessory Dwelling Units

Index # - File Name: 1.0022 - Single Family Dwellings Data\_Snohomish County.pdf

Closed	0088600000600
Closed	00394510400800
Closed	00513700008210
Closed	00513700008211
Closed	00513700008212
Closed	00897500000100
Closed	00897500000200
Closed	00897500000300
Closed	00897500000400
Closed	00897500000500
Closed	00897500000600
Closed	00897500000800
Closed	00897500000900
Closed	00897500001000
Closed	00897500001100
Closed	00897500001200
Closed	00897500001300
Closed	00897600000100
Closed	00897600000200
Closed	00897600000300
Closed	00897600000400
Closed	00897600000500
Closed	00897600000600
Closed	00897600000700
Closed	00897600000800
Closed	00897600000900
Closed	00897600001100
Closed	00498800102400
Closed	27061800101100
Closed	00897900000400
Closed	00897900000500
Closed	00897900000600
Closed	00897900003500
Closed	00897900003600
Closed	00897900003700
Closed	00897900003800
Closed	00897900003900
Closed	00897900004000
Closed	00897900004100
Closed	00897900004200
Closed	00897900004300
Closed	00897900004600
Closed	00897900004700
Closed	00897900004800
Closed	00897900003200
Closed	00897900005400
Closed	00897900005800

Accessory Dwelling Units

Index # - File Name: 1.0022 - Single Family Dwellings Data\_Snohomish County.pdf

Closed	00897900005900
Closed	00897900006000
Closed	00897900006200
Closed	00897900006600
Closed	00897900006700
Closed	00897900006800
Closed	00897900007300
Closed	00897900007400
Closed	00897900007500
Closed	00897900007600
Closed	00897900007800
Closed	00897900008100
Closed	00897900008200
Closed	00897900008300
Closed	00897900007100
Closed	00897900008600
Closed	00897900008700
Closed	00897900008800
Closed	00897900008900
Closed	00897900009000
Closed	00897900009100
Closed	00895000000100
Closed	00895000000200
Closed	00895000000300
Closed	00895000000400
Closed	00895000000500
Closed	00895000000600
Closed	00895000000700
Closed	00895000000800
Closed	00895000000900
Closed	00895000001000
Closed	00895000001100
Closed	00895000001200
Closed	00895000001300
Closed	00895000001400
Closed	00895000001500
Closed	00895000001600
Closed	00895000001700
Closed	00895000001800
Closed	00895000001900
Closed	00895000002000
Closed	00895000002100
Closed	00895000002200
Closed	00895000002300
Closed	00895000002400
Closed	00895000002500
Closed	00895000002600

Accessory Dwelling Units

Index # - File Name: 1.0022 - Single Family Dwellings Data\_Snohomish County.pdf

Closed	32053300103900
Closed	32053300104000
Closed	32053300104100
Closed	32053300104200
Closed	00493300900505
Closed	00493300900506
Closed	00538000001602
Closed	00538000001603
Closed	00538000001604
Closed	00538000010901
Closed	00538000010902
Closed	00538000010903
Closed	00538000010904
Closed	30051200102700
Closed	30042400102700
Closed	00493400800300
Closed	28070600402300
Closed	00896100000100
Closed	00896100000200
Closed	00896100000300
Closed	00896100000400
Closed	00896100000500
Closed	00896100000600
Closed	00896100000700
Closed	00896100000800
Closed	00896100000900
Closed	00896100001000
Closed	00896100001100
Closed	00896100001200
Closed	00896100001300
Closed	00896100001400
Closed	00896100001500
Closed	00896300000100
Closed	00896300000200
Closed	00896300000300
Closed	00896300000400
Closed	00896300000500
Closed	00896300000600
Closed	00896300000700
Closed	00896300000800
Closed	00896300000900
Closed	00895800000300
Closed	00895800000600
Closed	00895800000800
Closed	00895800000900
Closed	00895800001200
Closed	00895800001300



Accessory Dwelling Units

Index # - File Name: 1.0022 - Single Family Dwellings Data\_Snohomish County.pdf

Closed	00895900000500
Closed	00895900000600
Closed	00895900000700
Closed	29063600102400
Closed	32092500201000
Closed	28063200400600
Closed	27051400101200
Closed	00895900001000
Closed	00895900001100
Closed	00895900001200
Closed	30061500302300
Closed	00577700604600
Closed	32063200102700
Closed	32053300400100
Closed	00460200019800
Closed	32053300302300
Closed	30040200401400
Closed	27071100301100
Closed	00896400000400
Closed	00896400000500
Closed	00896400000600
Closed	00896400000700
Closed	00896400000800
Closed	00896400000900
Closed	00896400001000
Closed	31063300101300
Closed	29061400301400
Closed	30050200100800
Closed	00896400001900
Closed	00896400002000
Closed	00896400002100
Closed	00896400001600
Closed	00896400002500
Closed	32080100302500
Closed	28073000202300
Closed	28073000202200
Closed	00897900009400
Closed	00897900009500
Closed	00897900009600
Closed	00897900010000
Closed	00897900010100
Closed	00897900010200
Closed	00897900010600
Closed	00897900010700
Closed	00897900010900
Closed	00897900012300
Closed	00897900012400

Accessory Dwelling Units

Index # - File Name: 1.0022 - Single Family Dwellings Data\_Snohomish County.pdf

Closed	00590700004700
Closed	00898000000200
Closed	00898000000300
Closed	31063000302400
Closed	00897700000100
Closed	00897700000200
Closed	00897700000300
Closed	00897700000500
Closed	00897700000600
Closed	00897700000700
Closed	00897700000800
Closed	00897700000900
Closed	29060900301400
Closed	00897900011700
Closed	00897900011800
Closed	00897900011900
Closed	00897900012000
Closed	00897900012100
Closed	00509300003905
Closed	28093100404200
Closed	00898700000200
Closed	00898700000300
Closed	00898700000400
Closed	00898700000500
Closed	00898700000600
Closed	00898700000700
Closed	28073200402200
Closed	00898700001100
Closed	00898700001200
Closed	00898700001400
Closed	00898700001500
Closed	28083600403200
Closed	00403800000401
Closed	31063000302300
Closed	00677100002600
Closed	00960006500300
Closed	31053300401500
Closed	00627300008400
Closed	00590700005600
Closed	27062800101300
Closed	00372801400401
Closed	00403800001303
Closed	00403800001304
Closed	00403800001305
Closed	00403800001306
Closed	30052100112000
Closed	00509500002203

Accessory Dwelling Units

Index # - File Name: 1.0022 - Single Family Dwellings Data\_Snohomish County.pdf

Closed	00899500001600
Closed	00899500001700
Closed	00899500001800
Closed	00899500001900
Closed	00899500002000
Closed	00899500002100
Closed	00899500002200
Closed	00899500002300
Closed	00899500002400
Closed	00899500002500
Closed	00899500002600
Closed	00899500002700
Closed	00899500002800
Closed	00899500002900
Closed	00899500003000
Closed	00899500003100
Closed	00899500003200
Closed	00899500003300
Closed	00899500003400
Closed	00899500003500
Closed	00899500003600
Closed	00899500003700
Closed	00899500003800
Closed	00899500003900
Closed	00899500004000
Closed	00899500004100
Closed	00899500004200
Closed	00899500004300
Closed	00899500004400
Closed	00899500004500
Closed	00899500004600
Closed	00899500004700
Closed	00899500004800
Closed	00899500004900
Closed	00899500005000
Closed	00899500005100
Closed	00899500005200
Closed	00899500005300
Closed	00899500005400
Closed	00899500005500
Closed	00899500005600
Closed	00899500005700
Closed	00899500005800
Closed	00899500005900
Closed	00899500006000
Closed	00899500008700
Closed	00489800000602

Accessory Dwelling Units

Index # - File Name: 1.0022 - Single Family Dwellings Data\_Snohomish County.pdf

Closed	00373700300301
Closed	30042600401700
Closed	00899900000100
Closed	00899900000200
Closed	00899900000300
Closed	00899900000400
Closed	00899900000500
Closed	00899900000600
Closed	00899900000700
Closed	00899900000800
Closed	00899900000900
Closed	00899900001000
Closed	00899900001300
Closed	00899900001400
Closed	00899900002300
Closed	00511900200301
Closed	00900000000100
Closed	00900000000200
Closed	00900000000300
Closed	00900000000600
Closed	00900000000700
Closed	00900000000800
Closed	00900000001200
Closed	00900000001300
Closed	00900000001400
Closed	00900000001500
Closed	00900000001600
Closed	00900000001800
Closed	00900000001900
Closed	00900000002000
Closed	00900000001000
Closed	00900000002200
Closed	00394401600600
Closed	00374700000401
Closed	28052900304300
Closed	00900500000700
Closed	00900500000800
Closed	00900500000900
Closed	00900500001000
Closed	00900500001300
Closed	00900500001400
Closed	00900500001700
Closed	00900500002000
Closed	00900500002100
Closed	00900500002200
Closed	00900500002300
Closed	00900500002500

Accessory Dwelling Units

Index # - File Name: 1.0022 - Single Family Dwellings Data\_Snohomish County.pdf

Closed	00900500002700
Closed	00900500002900
Closed	00900500003600
Closed	00900500004000
Closed	00900500004100
Closed	00900500004600
Closed	00900500004700
Closed	00900500004800
Closed	00900500004400
Closed	00900500005400
Closed	00900500005500
Closed	00900500006000
Closed	00900500006100
Closed	32063000402100
Closed	00900600000800
Closed	00900600000900
Closed	00900600001000
Closed	00900600001100
Closed	00900600001200
Closed	00900600001300
Closed	00900600001400
Closed	00900600001500
Closed	00900500007200
Closed	00570600202002
Closed	00570600202003
Closed	00570600202004
Closed	32100400201600
Closed	00881842000200
Closed	00900800000300
Closed	00900800000400
Closed	00900800001200
Closed	00906000001600
Closed	00906000001700
Closed	00627300008200
Closed	00960002301400
Closed	00960002301500
Closed	00901500000300
Closed	00901500000400
Closed	00901500000500
Closed	00901300000100
Closed	00901300000200
Closed	00901300000300
Closed	00901300000400
Closed	00901300000500
Closed	00901300000600
Closed	00901300001000
Closed	00901300001500

Accessory Dwelling Units

Index # - File Name: 1.0022 - Single Family Dwellings Data\_Snohomish County.pdf

Closed	00901300001200
Closed	00901300001300
Closed	00901300002900
Closed	00901600000700
Closed	00901600000800
Closed	00901600000900
Closed	00901600001000
Closed	00901600001100
Closed	00901600001200
Closed	30050900107100
Closed	00904000000100
Closed	00901800000200
Closed	00901800000400
Closed	00901800000600
Closed	00901600000100
Closed	00901600000200
Closed	00901600000300
Closed	00901600000400
Closed	00901600000500
Closed	00901700000400
Closed	00901700000500
Closed	00902200001300
Closed	00902200001400
Closed	00902200001500
Closed	00902200003400
Closed	00902200003500
Closed	00902200003600
Closed	00902200003700
Closed	00902200003800
Closed	00902200004400
Closed	00902800000100
Closed	00902800000200
Closed	00902800000300
Closed	00902800000400
Closed	00902800000800
Closed	00902800000900
Closed	00902800001000
Closed	00902800001100
Closed	00902800001200
Closed	00902600000100
Closed	00902600000200
Closed	00902600002200
Closed	00902600000700
Closed	00902600001500
Closed	00902700000200
Closed	00902700000300
Closed	00902700000500

Accessory Dwelling Units

Index # - File Name: 1.0022 - Single Family Dwellings Data\_Snohomish County.pdf

Closed	00902700000700
Closed	00902900000300
Closed	00902900000400
Closed	00902900000700
Closed	00902900001800
Closed	00902900002300
Closed	28072000202600
Closed	00903900002900
Closed	28061200401400
Closed	00394401600800
Closed	00419500001800
Closed	32051600401000
Closed	31042600401000
Closed	00513700007214
Closed	28061300400600
Closed	30052200308200
Closed	30052200308400
Closed	30052200308500
Closed	31041000101800
Closed	31062900100200
Closed	00906000001800
Closed	00906000001900
Closed	00906000002000
Closed	00906000002100
Closed	00906000002200
Closed	00906000002300
Closed	00906000002400
Closed	00906000002500
Closed	00906000002600
Closed	00906000002700
Closed	00906000002800
Closed	00906000002900
Closed	00906000003000
Closed	00906000003100
Closed	00906000003200
Closed	00906000003400
Closed	00906000003500
Closed	00906000003600
Closed	00906000003700
Closed	00906000003800
Closed	00906000003900
Closed	00906000004000
Closed	00906000004200
Closed	00906000004300
Closed	00906000004400
Closed	00906000004500
Closed	00906000004600

Accessory Dwelling Units

Index # - File Name: 1.0022 - Single Family Dwellings Data\_Snohomish County.pdf

Closed	0090600004700
Closed	0090600004800
Closed	0090600004900
Closed	0090600005000
Closed	0090600005100
Closed	0090600005200
Closed	0090600005300
Closed	0090600005400
Closed	0090600005500
Closed	0090600005600
Closed	0090600005700
Closed	0090600005800
Closed	0090600005900
Closed	0090600006000
Closed	0059740000207
Closed	00373100401109
Closed	00373100401108
Closed	00557500000601
Closed	32053400203100
Closed	31062700301300
Closed	32041400300400
Closed	00906900000900
Closed	00906900001000
Closed	00906900001100
Closed	00906900001200
Closed	00906900001300
Closed	00906900001400
Closed	00906900001500
Closed	00906900001600
Closed	00906900001700
Closed	00906900001800
Closed	00906900001900
Closed	00906900002100
Closed	00906900002200
Closed	00906900002300
Closed	00906900002400
Closed	00906900002500
Closed	00906900002600
Closed	00906900002700
Closed	00906900002800
Closed	00906900002900
Closed	00906900003000
Closed	00906900003200
Closed	00906900003300
Closed	00906900003400
Closed	00906900003500
Closed	00906900003600



Accessory Dwelling Units

Index # - File Name: 1.0022 - Single Family Dwellings Data\_Snohomish County.pdf

Closed	00906900003700
Closed	00906900003800
Closed	00599300000100
Closed	00599300000200
Closed	00575100000402
Closed	32090800100400
Closed	00907100000100
Closed	00907100000200
Closed	00907100000300
Closed	00907100000400
Closed	00907100000500
Closed	00907100000600
Closed	00907100000700
Closed	00907100000800
Closed	00907100000900
Closed	00907100001000
Closed	00906900004600
Closed	00906900004700
Closed	00906900004800
Closed	00906900004900
Closed	00906900005000
Closed	00906900005100
Closed	00466900009900
Closed	00556800100900
Closed	00587000003800
Closed	30041300401100
Closed	00582500400900
Closed	00915300001000
Closed	00915300000800
Closed	00907600000100
Closed	00907600000200
Closed	00907600000300
Closed	00907600000400
Closed	00907600000500
Closed	00907600000600
Closed	00907600000700
Closed	00907600000800
Closed	00907600000900
Closed	00907600001000
Closed	00907600001100
Closed	00907600001200
Closed	00907600001300
Closed	00907600001400
Closed	00907600001500
Closed	00907600001600
Closed	00907600001700
Closed	00907600001800

Accessory Dwelling Units

Index # - File Name: 1.0022 - Single Family Dwellings Data\_Snohomish County.pdf

Closed	00907600002000
Closed	00907600002100
Closed	00907600002200
Closed	00907600002300
Closed	00907600002400
Closed	00907600002500
Closed	00907600002900
Closed	00907600002600
Closed	00907600002700
Closed	00907600003200
Closed	00907600003400
Closed	00907600003600
Closed	00907600003700
Closed	00907600003800
Closed	00907600003900
Closed	00907600004000
Closed	00915300000600
Closed	00915300000400
Closed	00915300000200
Closed	00907500000800
Closed	00907400000400
Closed	00907400000500
Closed	00907400000600
Closed	00907400000700
Closed	00907400000800
Closed	00907400001000
Closed	00907400001100
Closed	00907600004300
Closed	00907600004400
Closed	00907600004500
Closed	00907600004600
Closed	00907600004700
Closed	00907600004800
Closed	00907600005000
Closed	00907600005100
Closed	00907600005200
Closed	00907600001900
Closed	00907600002800
Closed	00907600003100
Closed	00907600003300
Closed	00907600003500
Closed	00907600004900
Closed	00625200012000
Closed	00907700000100
Closed	00907700000200
Closed	00907700000300
Closed	00907700000400

Accessory Dwelling Units

Index # - File Name: 1.0022 - Single Family Dwellings Data\_Snohomish County.pdf

Closed	00907700000500
Closed	00907700000600
Closed	00907700000700
Closed	00907700000800
Closed	00907700000900
Closed	00907700001000
Closed	00907700001100
Closed	00907700001200
Closed	00907700001300
Closed	00907700001400
Closed	00907700001500
Closed	00907700001600
Closed	00490500001200
Closed	27063400101100
Closed	00499100103400
Closed	00490100006000
Closed	00403800011202
Closed	28083000202000
Closed	00373002600310
Closed	00960003006400
Closed	00908400000600
Closed	00908400000300
Closed	00908400000200
Closed	00908400000500
Closed	00908400000100
Closed	00908400000700
Closed	00908400001000
Closed	00908400000900
Closed	00908400000800
Closed	00908400001100
Closed	00908400000400
Closed	00908400001300
Closed	00908400001400
Closed	00908400001200
Closed	00908600000700
Closed	00908600000800
Closed	00908600000900
Closed	00587200002500
Closed	00908600000200
Closed	00908600000600
Closed	00908600001000
Closed	28062500400400
Closed	00902900001900
Closed	00902900002100
Closed	00902900002500
Closed	00401000009500
Closed	00569000003402

Accessory Dwelling Units

Index # - File Name: 1.0022 - Single Family Dwellings Data\_Snohomish County.pdf

Closed	00569000003403
Closed	00569000003404
Closed	00903200000100
Closed	00903200000200
Closed	00903200000400
Closed	00903200000500
Closed	00903200000600
Closed	00902900000200
Closed	00903200000800
Closed	00903200001000
Closed	00903200001100
Closed	31063000100400
Closed	00903100000100
Closed	00903100000200
Closed	00903100000300
Closed	00903100000400
Closed	00903100000500
Closed	00903100000600
Closed	00903100000700
Closed	00903100000800
Closed	00903100000900
Closed	00903100001000
Closed	00903100001100
Closed	00903100001200
Closed	00903100001300
Closed	00903100001400
Closed	00903100001500
Closed	00903100001700
Closed	00903100001800
Closed	00903100001900
Closed	00903100002000
Closed	00903100002100
Closed	00903100002200
Closed	00903100002300
Closed	00903100002400
Closed	00903100002500
Closed	00903100002600
Closed	00903100002700
Closed	00903100002800
Closed	00903100002900
Closed	00903100003000
Closed	00903100003300
Closed	00903100003400
Closed	00903100003700
Closed	00903100003800
Closed	00903100004900
Closed	00903100004200

Accessory Dwelling Units

Index # - File Name: 1.0022 - Single Family Dwellings Data\_Snohomish County.pdf

Closed	00903100004300
Closed	00903100004400
Closed	00903100004500
Closed	00903100004600
Closed	00903100004700
Closed	00903100005100
Closed	00903100005200
Closed	00903100005300
Closed	00903100005400
Closed	00903100005500
Closed	00903100005600
Closed	00903100005700
Closed	00903100005800
Closed	00903100005900
Closed	00903100001600
Closed	00903100003100
Closed	00903100003200
Closed	00903100004800
Closed	00903100005000
Closed	00903100003900
Closed	00401000009900
Closed	00903900000200
Closed	00903900000100
Closed	00903900000600
Closed	00903900000700
Closed	00903900000800
Closed	00903900000900
Closed	00903900001000
Closed	00903900001200
Closed	00903900001300
Closed	00903900001400
Closed	00903900001500
Closed	00903900001600
Closed	00903900001700
Closed	00903900001900
Closed	00903900002100
Closed	00903900002000
Closed	00903900002200
Closed	00903900002300
Closed	00903900002500
Closed	00903900002400
Closed	00903900002600
Closed	00903900002800
Closed	00466100001500
Closed	00904000000200
Closed	00904000000300
Closed	00904000000700

Accessory Dwelling Units

Index # - File Name: 1.0022 - Single Family Dwellings Data\_Snohomish County.pdf

Closed	0090400000800
Closed	0090400000900
Closed	0090400001400
Closed	0090400001500
Closed	29070500201200
Closed	00520200000500
Closed	00904000003700
Closed	00904000003800
Closed	00904000003900
Closed	00904000005400
Closed	00904100000100
Closed	00904100000200
Closed	00904100000300
Closed	00904100000400
Closed	00904100000500
Closed	00904100000600
Closed	00904100000700
Closed	00904100000800
Closed	00904100000900
Closed	00904100001000
Closed	00904100001100
Closed	00904100001200
Closed	00904100001300
Closed	00904100001400
Closed	00904100001500
Closed	00904100001600
Closed	00904100001700
Closed	00904100001800
Closed	00904100001900
Closed	00904100002000
Closed	00904100002100
Closed	00904100002200
Closed	00904100002400
Closed	00904100002500
Closed	00904100002600
Closed	00904100002700
Closed	00904100002800
Closed	00904100002900
Closed	00904100003000
Closed	00904100003100
Closed	00904100003200
Closed	00904100003300
Closed	00904100003400
Closed	00904100003500
Closed	00904100003700
Closed	00904100003600
Closed	00904100003800

Accessory Dwelling Units

Index # - File Name: 1.0022 - Single Family Dwellings Data\_Snohomish County.pdf

Closed	00904100003900
Closed	00904000004200
Closed	00904000005000
Closed	00904000005100
Closed	00480401707402
Closed	00480401707403
Closed	00480401707500
Closed	00480401707604
Closed	00904000004700
Closed	27051100100100
Closed	00905600001700
Closed	00905600001600
Closed	00905600001500
Closed	00905600001400
Closed	00905600001300
Closed	00905600001200
Closed	00905600001100
Closed	00905600001000
Closed	00905600000900
Closed	00905600000800
Closed	00905600000700
Closed	00905600000600
Closed	00905600000500
Closed	00905600000400
Closed	00905600000300
Closed	00905600000200
Closed	00905600000100
Closed	00905600004000
Closed	00905600003900
Closed	00905600003800
Closed	00905600003700
Closed	00905600003600
Closed	00905600003500
Closed	00905600003400
Closed	00905600003300
Closed	00905600003200
Closed	00905600003100
Closed	00905600002900
Closed	00905600002800
Closed	00905600002700
Closed	00905600002500
Closed	00905600002600
Closed	00905600002400
Closed	00905600002300
Closed	00905600002200
Closed	00905600002100
Closed	00905600002000

Accessory Dwelling Units

Index # - File Name: 1.0022 - Single Family Dwellings Data\_Snohomish County.pdf

Closed	00905600001900
Closed	00905600001800
Closed	00905600003000
Closed	00960006604800
Closed	28061300102000
Closed	28061300102100
Closed	28061300102200
Closed	28061300102300
Closed	00490400001000
Closed	00905700000100
Closed	00905700000200
Closed	00905700000300
Closed	00905700000400
Closed	00905700000500
Closed	00905700000600
Closed	00905700000700
Closed	00905700000800
Closed	00905700000900
Closed	00905700001000
Closed	00905700001100
Closed	00905700001200
Closed	00905700001300
Closed	00905700001400
Closed	00905700001500
Closed	00905700001600
Closed	00905700001700
Closed	00905700001800
Closed	00905900000100
Closed	00905900000200
Closed	00905900000300
Closed	00905900000400
Closed	00905900000500
Closed	00905900000600
Closed	00905900000700
Closed	00905900000800
Closed	00905900000900
Closed	00905900001000
Closed	00905900001100
Closed	00905900001200
Closed	00905900001300
Closed	00905900001400
Closed	00905900001500
Closed	00905900001600
Closed	00905900001700
Closed	00905900001800
Closed	30050300101600
Closed	00905800000100



Accessory Dwelling Units

Index # - File Name: 1.0022 - Single Family Dwellings Data\_Snohomish County.pdf

Closed	0090580000200
Closed	0090580000300
Closed	0090580000400
Closed	0090580000500
Closed	0090580000600
Closed	0090580000700
Closed	0090580000800
Closed	0090580000900
Closed	0090580001200
Closed	0090580001300
Closed	0090580001400
Closed	0090580001500
Closed	0090580001600
Closed	0090580001700
Closed	0090580001800
Closed	0090580001900
Closed	00498800102800
Closed	0090600000100
Closed	0090600000200
Closed	0090600000300
Closed	0090600000400
Closed	0090600000500
Closed	0090600000600
Closed	0090600000700
Closed	0090600000800
Closed	0090600000900
Closed	0090600001000
Closed	0090600001100
Closed	0090600001200
Closed	27063400400700
Closed	0090900000100
Closed	0090900000200
Closed	0090900000300
Closed	0090900000400
Closed	0090900000500
Closed	0090900000600
Closed	0090900000700
Closed	0090900000800
Closed	0090900001200
Closed	0090900001300
Closed	0090900001400
Closed	0090900001500
Closed	0090900001600
Closed	0090900001700
Closed	0090900001800
Closed	0090900001900
Closed	0090900002000

Accessory Dwelling Units

Index # - File Name: 1.0022 - Single Family Dwellings Data\_Snohomish County.pdf

Closed	00909000002100
Closed	00909000002200
Closed	00909000002300
Closed	00909000002400
Closed	00509000004405
Closed	00909200000100
Closed	00909200000200
Closed	00909200000300
Closed	00909200000400
Closed	00909200000500
Closed	00909200000600
Closed	00909200000700
Closed	00909200000800
Closed	00909200000900
Closed	00909200001000
Closed	00909200001100
Closed	00909200001200
Closed	00909200001300
Closed	00909200001400
Closed	00909200001500
Closed	00909200001600
Closed	00909200001700
Closed	00909200001800
Closed	00909200001900
Closed	00538500000802
Closed	00909200002000
Closed	00909200002100
Closed	00909200002200
Closed	00909200002300
Closed	00909200002400
Closed	00909200002500
Closed	00909200002600
Closed	00909200002700
Closed	00909200002800
Closed	00909200002900
Closed	00909200003000
Closed	00909200003100
Closed	00909200003200
Closed	00909200003300
Closed	00909200003400
Closed	00909200003500
Closed	00909200003600
Closed	00909200003700
Closed	00909200003800
Closed	00909200004000
Closed	00909200004100
Closed	00908600000400

Accessory Dwelling Units

Index # - File Name: 1.0022 - Single Family Dwellings Data\_Snohomish County.pdf

Closed	28070700300400
Closed	00908500000200
Closed	00908500000300
Closed	00908500001100
Closed	00908500001200
Closed	00908500001300
Closed	00908500001400
Closed	00908500000600
Closed	00908500000700
Closed	00908500000800
Closed	00908500002100
Closed	00908500002600
Closed	00908500002700
Closed	00908500002800
Closed	00908500003000
Closed	00908500003200
Closed	00908500003300
Closed	00908500003400
Closed	00908500003500
Closed	00908500003700
Closed	00908500003800
Closed	00908500003900
Closed	00908500004000
Closed	00908500004100
Closed	00908500004300
Closed	00908500004400
Closed	00908500004500
Closed	00908500004600
Closed	00908500004700
Closed	27063400101500
Closed	00908800005000
Closed	00908800005100
Closed	00908800005200
Closed	00908800005300
Closed	00908800005400
Closed	00908800005500
Closed	00908800005600
Closed	00908800005700
Closed	00908800005900
Closed	00908800006000
Closed	00908800006100
Closed	00908800006300
Closed	00908800006500
Closed	00908800006600
Closed	00908800006700
Closed	00908800007000
Closed	00908800007100

Accessory Dwelling Units

Index # - File Name: 1.0022 - Single Family Dwellings Data\_Snohomish County.pdf

Closed	00908800007200
Closed	00908800007300
Closed	00908800007400
Closed	00908800007500
Closed	00908800007600
Closed	00908800007700
Closed	00908800007800
Closed	00908800007900
Closed	00909100000200
Closed	00909100000300
Closed	00909100000400
Closed	00909100000500
Closed	00909100000600
Closed	00909100000700
Closed	00909100000800
Closed	00909100000900
Closed	00909100001000
Closed	00909100001100
Closed	00909100001200
Closed	00909100001400
Closed	00909100001500
Closed	00909100001600
Closed	00909100001700
Closed	00909100002400
Closed	00909100002500
Closed	00909100009400
Closed	00909100002000
Closed	00909100003700
Closed	00909100011000
Closed	00909100004800
Closed	00909100004900
Closed	00909100005000
Closed	00909100005100
Closed	00909100002300
Closed	00909100005200
Closed	00909100005300
Closed	00909100002700
Closed	00909100003500
Closed	00909100000100
Closed	00909100002200
Closed	00909100003900
Closed	00909100004000
Closed	00909100006800
Closed	00909100010600
Closed	00909100003800
Closed	00909100002800
Closed	00909100002600

Accessory Dwelling Units

Index # - File Name: 1.0022 - Single Family Dwellings Data\_Snohomish County.pdf

Closed	00909100009200
Closed	00909100009800
Closed	00909100003600
Closed	00909100004500
Closed	00909100001800
Closed	00909100001900
Closed	00909100011400
Closed	00909100010500
Closed	00909100010800
Closed	00909100009900
Closed	00909100011100
Closed	00909100010000
Closed	00909100008800
Closed	00909100011600
Closed	00909100011300
Closed	00909100011200
Closed	00909100008900
Closed	00909100009500
Closed	00909100008700
Closed	00909100010100
Closed	00909100010900
Closed	00909100011700
Closed	00909100009700
Closed	00909100009100
Closed	00909100010400
Closed	00909100009000
Closed	27051000203800
Closed	00372601100811
Closed	00372601100810
Closed	00372601100809
Closed	29060400200300
Closed	00374900003401
Closed	00909800000100
Closed	00909800000200
Closed	00909800000300
Closed	00909800000400
Closed	00909800000500
Closed	00909800000600
Closed	00909800000700
Closed	00909800000800
Closed	00909800000900
Closed	00909800001000
Closed	00909800001100
Closed	00909800001200
Closed	00909800001300
Closed	00909800001400
Closed	00909800001500

Accessory Dwelling Units

Index # - File Name: 1.0022 - Single Family Dwellings Data\_Snohomish County.pdf

Closed	00909800001600
Closed	00909800001700
Closed	00909800001800
Closed	00909800001900
Closed	00909800002000
Closed	00909800002100
Closed	00909800002200
Closed	00909800002300
Closed	00909800002400
Closed	00909800002500
Closed	00909800002600
Closed	00909800002700
Closed	00909800002800
Closed	00909800002900
Closed	00909800005200
Closed	00909800003000
Closed	00909800003100
Closed	00909800003200
Closed	00909800003300
Closed	00909800003400
Closed	00909800003500
Closed	00909800003600
Closed	00909800003700
Closed	00909800003800
Closed	00909800003900
Closed	00909800004000
Closed	00909800004100
Closed	00909800004200
Closed	00909800004300
Closed	00909800004400
Closed	00909800004500
Closed	00909800004600
Closed	00909800004700
Closed	00909800004800
Closed	00909800005000
Closed	00909800004900
Closed	00909800005100
Closed	00909100010700
Closed	00909100010200
Closed	00909100010300
Closed	00909100009600
Closed	00909500002400
Closed	00909500002300
Closed	00909500001800
Closed	00909500001700
Closed	00909500001600
Closed	00909500001500

Accessory Dwelling Units

Index # - File Name: 1.0022 - Single Family Dwellings Data\_Snohomish County.pdf

Closed	00909500002100
Closed	00909500001300
Closed	00909500001100
Closed	27090800104300
Closed	00910000000500
Closed	00910000000100
Closed	00910000000700
Closed	00910000000800
Closed	00910000000900
Closed	00910000001000
Closed	00910000001100
Closed	00910000001200
Closed	00910000002800
Closed	00910000000600
Closed	00634300000601
Closed	31042200102300
Closed	00499100103100
Closed	00910000003900
Closed	00910000004000
Closed	00910000003800
Closed	00910000001500
Closed	00910500001000
Closed	00910500000200
Closed	00910500000300
Closed	00910500000400
Closed	00910500000500
Closed	00910500000100
Closed	00910500000900
Closed	00910500000800
Closed	00910500000600
Closed	00910500000700
Closed	00910500001100
Closed	00910500001200
Closed	00910500001300
Closed	00420400000301
Closed	00911000000100
Closed	00911000000200
Closed	00911000000300
Closed	00911000000400
Closed	00911000000500
Closed	00911000000600
Closed	00911000000700
Closed	00911000000800
Closed	00911000000900
Closed	00911000001100
Closed	00911000001200
Closed	00911000001300

Accessory Dwelling Units

Index # - File Name: 1.0022 - Single Family Dwellings Data\_Snohomish County.pdf

Closed	00911000001400
Closed	00911000001500
Closed	00911000001600
Closed	00910000000300
Closed	00910000000400
Closed	28052900403700
Closed	28083400201100
Closed	31060800101000
Closed	00533400004501
Closed	00911300002200
Closed	00911300001900
Closed	00911300000300
Closed	27071900100700
Closed	00570400300302
Closed	00570400300300
Closed	00902900001100
Closed	00902900001200
Closed	00902900001300
Closed	00902900001400
Closed	00902900001500
Closed	00902900001600
Closed	00902900001700
Closed	00902900000500
Closed	00902900000600
Closed	00902700000800
Closed	00902700000600
Closed	00902700000400
Closed	00902600001600
Closed	00902600001700
Closed	00902600001800
Closed	00902600001900
Closed	00902600002000
Closed	00902600002100
Closed	00902600000800
Closed	00902600000900
Closed	00902600001000
Closed	00902600001100
Closed	00902600001200
Closed	00902600001300
Closed	00902600001400
Closed	00902600002300
Closed	00902600002400
Closed	00902600002500
Closed	00902600002600
Closed	00902600002700
Closed	00902600002800
Closed	00902600002900



Accessory Dwelling Units

Index # - File Name: 1.0022 - Single Family Dwellings Data\_Snohomish County.pdf

Closed	00902600003000
Closed	00902600003100
Closed	00902600003200
Closed	00902600003300
Closed	00902600003400
Closed	00902600003500
Closed	00902600003600
Closed	00902600003700
Closed	00902600000300
Closed	00902600000400
Closed	00902600000500
Closed	00902600000600
Closed	00902800000500
Closed	00902800000600
Closed	31062000202800
Closed	00390200000400
Closed	00902200004500
Closed	00902200004600
Closed	00902200004700
Closed	00902200004800
Closed	31052400201900
Closed	30060700203300
Closed	00902200003900
Closed	00902200004000
Closed	00902200004100
Closed	00902200004200
Closed	00902200004300
Closed	00902200001600
Closed	00902200001700
Closed	00902200001900
Closed	00902200002000
Closed	00902200002100
Closed	00902200002200
Closed	00902200002300
Closed	00902200002400
Closed	00902200002500
Closed	00902200002600
Closed	00902200002700
Closed	00902200002800
Closed	00902200002900
Closed	00902200003000
Closed	00902200003100
Closed	00902200003200
Closed	00372900600500
Closed	00372900600500
Closed	00372900600500
Closed	00372900600500

Accessory Dwelling Units

Index # - File Name: 1.0022 - Single Family Dwellings Data\_Snohomish County.pdf

Closed	00372900600500
Closed	00372900600500
Closed	00372900600500
Closed	00372900600500
Closed	00372900600500
Closed	00372900600500
Closed	00372900600500
Closed	00372900600500
Closed	00372900600500
Closed	00372900600500
Closed	00372900600500
Closed	00372900600500
Closed	00372900600500
Closed	00372900600500
Closed	00372900600500
Closed	00372900600500
Closed	27090500101700
Closed	27090800103800
Closed	00372900600500
Closed	00372900600500
Closed	00923400002700
Closed	00372900600500
Closed	00372900600500
Closed	00372900600500
Closed	00372900600500
Closed	00372900600500
Closed	00372900600500
Closed	00372900600500
Closed	00372900600500
Closed	00372900600500
Closed	00372900600500
Closed	00372900600500
Closed	00372900600500
Closed	00923400003700
Closed	00372900600500
Closed	00372900600500
Closed	30070400200600
Closed	27062000202900
Closed	00903200001300
Closed	00903200001400
Closed	00903200001500
Closed	00903200001600
Closed	00903200001700
Closed	00903200001800
Closed	00903200001900
Closed	00903200002000
Closed	00903200002100
Closed	00903200002200
Closed	00903200002300
Closed	00903200002400

Accessory Dwelling Units

Index # - File Name: 1.0022 - Single Family Dwellings Data\_Snohomish County.pdf

Closed	00903200002500
Closed	00903200002600
Closed	00903200002700
Closed	00903200002800
Closed	00903200002900
Closed	00903200003000
Closed	00903200003100
Closed	00903200003200
Closed	00903200003300
Closed	00903200003400
Closed	00903200003500
Closed	00903200003600
Closed	00903200003700
Closed	00903200003800
Closed	00903200003900
Closed	00903200004000
Closed	00903200004100
Closed	00903200004200
Closed	00903200004300
Closed	00903200004400
Closed	00903200004500
Closed	00903200004600
Closed	00903200004700
Closed	00903200004800
Closed	00903200004900
Closed	00903200005000
Closed	00903200005100
Closed	00903200005200
Closed	00903200005300
Closed	00903200005400
Closed	00903200005500
Closed	00903200005600
Closed	00903200005700
Closed	00903200005800
Closed	00903200005900
Closed	00903200006000
Closed	00903200006100
Closed	00903200006200
Closed	00903200006300
Closed	00903200006400
Closed	00903200006500
Closed	00903200006600
Closed	00903200006700
Closed	00903200006800
Closed	00903200006900
Closed	00903200007000
Closed	00903200007100

Accessory Dwelling Units

Index # - File Name: 1.0022 - Single Family Dwellings Data\_Snohomish County.pdf

Closed	00903200007200
Closed	00903200007300
Closed	00903200007400
Closed	00903200007500
Closed	00903200007600
Closed	00903200007700
Closed	00903200007800
Closed	00903200007900
Closed	00903200008000
Closed	00903200008100
Closed	00903200008200
Closed	00903200008300
Closed	00903200008400
Closed	00903200008500
Closed	00903200008700
Closed	00903200008800
Closed	00903200008900
Closed	00903200009000
Closed	00903800000100
Closed	00903800000200
Closed	00903800000300
Closed	00903800000400
Closed	00903800000500
Closed	00903800000600
Closed	00903800000700
Closed	00903800000800
Closed	00903800000900
Closed	00903800001000
Closed	00903800001100
Closed	00903800001200
Closed	00903800001300
Closed	00903800001400
Closed	00903800001500
Closed	00903800001600
Closed	00903800001700
Closed	00903800001800
Closed	00903800001900
Closed	00903800002000
Closed	00903800002100
Closed	00903800002200
Closed	00903800002300
Closed	00903800002400
Closed	00903800002500
Closed	00903800002600
Closed	00903800002700
Closed	00903800002800
Closed	00903800002900

Accessory Dwelling Units

Index # - File Name: 1.0022 - Single Family Dwellings Data\_Snohomish County.pdf

Closed	00903800003000
Closed	00903800003100
Closed	00903800003200
Closed	00903800003300
Closed	00903800003400
Closed	00903800003500
Closed	00903800003600
Closed	00903800003700
Closed	00903800003800
Closed	00903800003900
Closed	00903800004000
Closed	00903800004100
Closed	00903800004200
Closed	00903800004300
Closed	00903800004400
Closed	00903800004500
Closed	00903800004600
Closed	00903800004700
Closed	00903800004800
Closed	00903800004900
Closed	00903800005000
Closed	00903800005100
Closed	00903800005200
Closed	00903800005300
Closed	00903800005400
Closed	00903800005500
Closed	00903800005600
Closed	00903800005700
Closed	00903800005800
Closed	00903800005900
Closed	00903800006000
Closed	00903800006100
Closed	00903800006200
Closed	00903800006300
Closed	00903800006400
Closed	00903800006500
Closed	00903800006600
Closed	00903800006700
Closed	00903800006800
Closed	00903800006900
Closed	00903800007000
Closed	00903500000100
Closed	00903500000200
Closed	00903500000300
Closed	00903500000400
Closed	00903500000500
Closed	00903500000600

Accessory Dwelling Units

Index # - File Name: 1.0022 - Single Family Dwellings Data\_Snohomish County.pdf

Closed	0090350000700
Closed	0090350000800
Closed	0090350000900
Closed	0090350001000
Closed	0090350001100
Closed	0090350001200
Closed	0090350001300
Closed	0090350001400
Closed	0090350001500
Closed	0090350001600
Closed	0090360000100
Closed	0090360000200
Closed	0090360000300
Closed	0090360000400
Closed	0090360000500
Closed	0090360000700
Closed	0090360000800
Closed	0090360000900
Closed	0090370000100
Closed	0090370000200
Closed	0090370000300
Closed	0090370000400
Closed	27042300210600
Closed	28072800400200
Closed	0090170000600
Closed	0090170000700
Closed	0090170000800
Closed	00476200200700
Closed	00476200200700
Closed	0090220000100
Closed	0090220000200
Closed	0090220000300
Closed	0090220000400
Closed	0090220000500
Closed	0090220000800
Closed	0090220000900
Closed	0090220001000
Closed	0090220001100
Closed	0090220001200
Closed	0090160000600
Closed	0090170000100
Closed	0090170000200
Closed	0090170000300
Closed	30050900107200
Closed	0090230000100
Closed	0090230000200
Closed	0090230000300

Accessory Dwelling Units

Index # - File Name: 1.0022 - Single Family Dwellings Data\_Snohomish County.pdf

Closed	00902300000400
Closed	00902300000500
Closed	00902300000600
Closed	00902300000700
Closed	00902300000800
Closed	00902300000900
Closed	00902300001000
Closed	00902300001100
Closed	00902300001200
Closed	00902300001300
Closed	00902300001400
Closed	00902300001500
Closed	00902300001600
Closed	00902300001700
Closed	00902300001800
Closed	00902300001900
Closed	00902300002000
Closed	00902300002100
Closed	00902300002200
Closed	00902300002300
Closed	00902300002400
Closed	00902300002600
Closed	00902300002700
Closed	00902300002800
Closed	00902300002900
Closed	00902300003000
Closed	00902300003100
Closed	00902300003200
Closed	00902300003300
Closed	00902300003400
Closed	00902400000100
Closed	00902400000200
Closed	00901600001300
Closed	00901600001400
Closed	00901600001500
Closed	00901600001600
Closed	00901600001700
Closed	00901600001800
Closed	00901600001900
Closed	00901600002000
Closed	00901600002100
Closed	00901600002200
Closed	00901600002300
Closed	00901600002400
Closed	00901600002500
Closed	00901600002600
Closed	00901600002700

Accessory Dwelling Units

Index # - File Name: 1.0022 - Single Family Dwellings Data\_Snohomish County.pdf

Closed	00901600002800
Closed	00901600002900
Closed	00901600003000
Closed	00901600003100
Closed	00901600003200
Closed	00901600003300
Closed	00901600003400
Closed	00901600003500
Closed	00901600003600
Closed	00901600003700
Closed	00901600003800
Closed	00901600003900
Closed	30062600100800
Closed	00901300003000
Closed	00901300003100
Closed	00901300001400
Closed	00901300002000
Closed	00901300002100
Closed	00901300002200
Closed	00901300002600
Closed	00901300002700
Closed	00901300002800
Closed	00901300001600
Closed	00901300001700
Closed	00901300001100
Closed	00901500000100
Closed	00901500000200
Closed	00901300000700
Closed	00901300000800
Closed	00901300000900
Closed	28061200401700
Closed	27060600300800
Closed	27060600300900
Closed	00551500011400
Closed	00900800001500
Closed	00480401707601
Closed	00900800000700
Closed	00900800000800
Closed	00900800000900
Closed	00900800001000
Closed	00900800001100
Closed	00900800000100
Closed	00900800000200
Closed	00900800001700
Closed	00900800001800
Closed	00900800001900
Closed	00900800002100



Accessory Dwelling Units

Index # - File Name: 1.0022 - Single Family Dwellings Data\_Snohomish County.pdf

Closed	00900800002200
Closed	00900800002300
Closed	00900800002400
Closed	00900800002500
Closed	00900800002600
Closed	00900800002700
Closed	31061900200200
Closed	27063400103000
Closed	00900500007400
Closed	00900700000300
Closed	00900700000400
Closed	00900600000100
Closed	00900600000200
Closed	00900600000300
Closed	00900600000400
Closed	00900600000500
Closed	00900600000600
Closed	00900600000700
Closed	00900500006200
Closed	00900500006400
Closed	00900500006600
Closed	00900500006900
Closed	00900500007000
Closed	00900500007100
Closed	00900500007600
Closed	00900500007700
Closed	00900500007800
Closed	00900500007900
Closed	00900500008000
Closed	00900500005600
Closed	00900500005700
Closed	00900500005800
Closed	00900500005900
Closed	00900500004500
Closed	00900500005100
Closed	00900500005200
Closed	00900500005300
Closed	00900500004900
Closed	00900500004200
Closed	00900500003800
Closed	00900500003900
Closed	00900500003000
Closed	00900500003100
Closed	00900500003200
Closed	00900500003300
Closed	00900500003400
Closed	00900500003500

Accessory Dwelling Units

Index # - File Name: 1.0022 - Single Family Dwellings Data\_Snohomish County.pdf

Closed	00900500002800
Closed	00900500002600
Closed	00900500002400
Closed	00900500001800
Closed	00500100002100
Closed	32053300402800
Closed	00900500001500
Closed	00900500001600
Closed	00900500001100
Closed	00900500001200
Closed	00900500000100
Closed	00900500000200
Closed	00900500000300
Closed	00900500000400
Closed	00900500000500
Closed	00900500000600
Closed	31040300200600
Closed	30060600100200
Closed	00900000001100
Closed	00900000002100
Closed	00900000001700
Closed	00900000000900
Closed	00900000000500
Closed	00483100001200
Closed	00899600000600
Closed	30070800200200
Closed	00899900002400
Closed	00899900001500
Closed	00899900001600
Closed	00899900001700
Closed	00899900001800
Closed	00899900001900
Closed	00899900002000
Closed	00899900002100
Closed	00899900002200
Closed	00899900001100
Closed	00899900001200
Closed	00899600000100
Closed	00899600000200
Closed	00899600000300
Closed	00899500006100
Closed	00899500006200
Closed	00899500006300
Closed	00899500006500
Closed	00899500006600
Closed	00899500006700
Closed	00899500006800

Accessory Dwelling Units

Index # - File Name: 1.0022 - Single Family Dwellings Data\_Snohomish County.pdf

Closed	00899500006900
Closed	00899500007000
Closed	00899500007100
Closed	00899500007200
Closed	00899500007300
Closed	00899500007400
Closed	00899500007500
Closed	00899500007600
Closed	00899500007700
Closed	00899500007800
Closed	00899500007900
Closed	00899500008000
Closed	00899500008100
Closed	00899500008200
Closed	00899500008300
Closed	00899500008400
Closed	00899500008500
Closed	00899500008600
Closed	00899500000100
Closed	00899500000200
Closed	00899500000300
Closed	00899500000400
Closed	00899500000500
Closed	00899500000600
Closed	00899500000700
Closed	00899500000800
Closed	00899500000900
Closed	00899500001000
Closed	00899500001100
Closed	00899500001200
Closed	00899500001300
Closed	00899500001400
Closed	00899500001500
Closed	00517000002701
Closed	00898700000100
Closed	32040500302300
Closed	32040500302400
Closed	32040500300900
Closed	31042100101600
Closed	00898700001600
Closed	32053300302400
Closed	00898700001300
Closed	00898700000800
Closed	00898700000900
Closed	00898700001000
Closed	31053400100700
Closed	29073000401200

Accessory Dwelling Units

Index # - File Name: 1.0022 - Single Family Dwellings Data\_Snohomish County.pdf

Closed	32042200200900
Closed	00897900010500
Closed	00897900011600
Closed	00897900012200
Closed	30062100100800
Closed	00897900011000
Closed	00897900010800
Closed	00897900011400
Closed	00897900009900
Closed	00896400002600
Closed	00896400002700
Closed	00896400001700
Closed	00896400001800
Closed	00896400002200
Closed	00896400002300
Closed	00896400002400
Closed	00373701003100
Closed	00896400000200
Closed	00896400001100
Closed	00896400001200
Closed	00401100013200
Closed	00401000005700
Closed	27061300301500
Closed	00552500000200
Closed	00442100001300
Closed	32062000402600
Closed	00895900001300
Closed	32043600400300
Closed	29061600401400
Closed	00895900000800
Closed	00895800001500
Closed	00895800001000
Closed	00895800000700
Closed	00895800000500
Closed	28070600402400
Closed	32090800202300
Closed	27071300100500
Closed	00590700026000
Closed	32051300201300
Closed	00897900009200
Closed	00897900009300
Closed	00897900007200
Closed	00897900007000
Closed	00897900008500
Closed	00897900007900
Closed	00897900006300
Closed	00897900006100

Accessory Dwelling Units

Index # - File Name: 1.0022 - Single Family Dwellings Data\_Snohomish County.pdf

Closed	00897900005500
Closed	00897900005600
Closed	00897900005700
Closed	00897900005300
Closed	00897900004900
Closed	00897900002500
Closed	00897900002600
Closed	00897900002800
Closed	00897900002900
Closed	00897900003000
Closed	00897900003100
Closed	00897900004400
Closed	00897900004500
Closed	00897900001600
Closed	00897900001700
Closed	00897900001800
Closed	00897900001900
Closed	00897900000300
Closed	00897900000700
Closed	00897900000800
Closed	00897900001200
Closed	00897900001300
Closed	00897900001400
Closed	32042600301800
Closed	27050900105800
Closed	00579100004704
Closed	00896400001400
Closed	27050900105500
Closed	00375000008601
Closed	00427100000200
Closed	00427100006100
Closed	00427100007100
Closed	00427100007200
Closed	28073000202800
Closed	00401000010000
Closed	00960005300700
Closed	31052000201700
Closed	30050200401000
Closed	32081200201900
Closed	00912200000500
Closed	00912200000600
Closed	00912200000700
Closed	00912200000800
Closed	00912200000900
Closed	00912200001000
Closed	00912200001100
Closed	00912200001200

Accessory Dwelling Units

Index # - File Name: 1.0022 - Single Family Dwellings Data\_Snohomish County.pdf

Closed	00912200003400
Closed	00912200003500
Closed	00912200003600
Closed	29062100204000
Closed	29062100204100
Closed	00912200002100
Closed	00912200001700
Closed	00912200001900
Closed	00912200002000
Closed	00401100005800
Closed	00912600000400
Closed	00912600000600
Closed	00912600000900
Closed	00912600002100
Closed	00912600000200
Closed	00912300000500
Closed	00912300000600
Closed	00912300000700
Closed	00912300000800
Closed	00912300000900
Closed	00912300001000
Closed	00912300001100
Closed	00912300001200
Closed	00551500010000
Closed	00912700001500
Closed	00912700000200
Closed	00912700000300
Closed	00912700000400
Closed	00912700000600
Closed	00912700000100
Closed	00912700000900
Closed	00912700001400
Closed	00912700001000
Closed	00912700001300
Closed	00394510700300
Closed	00913100000500
Closed	00913100001500
Closed	00913100000900
Closed	00600300400100
Closed	00913500002000
Closed	00913500002100
Closed	00913500002400
Closed	00913500003900
Closed	00913500004000
Closed	00913500004100
Closed	00913500004200
Closed	00913500004300

Accessory Dwelling Units

Index # - File Name: 1.0022 - Single Family Dwellings Data\_Snohomish County.pdf

Closed	00913500004400
Closed	00913500002300
Closed	00913500002200
Closed	00913500003000
Closed	00913500002900
Closed	00913500002800
Closed	00913500002700
Closed	00913500002600
Closed	00913500002500
Closed	00913500003100
Closed	00913500003800
Closed	00913500003700
Closed	00913500003600
Closed	00913500003500
Closed	00913500003400
Closed	00913500003300
Closed	00913500003200
Closed	00913100001000
Closed	00913100001400
Closed	00913100002100
Closed	00913100001700
Closed	00913300000100
Closed	00913300000200
Closed	00466900004400
Closed	00913100000600
Closed	00913400002000
Closed	00913400002100
Closed	00913400000600
Closed	00913400000700
Closed	00913400000800
Closed	00913400000900
Closed	00913600000100
Closed	00913600000200
Closed	00913600000300
Closed	00913600000400
Closed	00913800000100
Closed	00913800000200
Closed	00913800000300
Closed	00913800000400
Closed	00913800000500
Closed	00913800000600
Closed	00913800000700
Closed	00913800000800
Closed	00913800000900
Closed	00914700100200
Closed	00914700201800
Closed	00914700201500

Accessory Dwelling Units

Index # - File Name: 1.0022 - Single Family Dwellings Data\_Snohomish County.pdf

Closed	00914600002600
Closed	00914600002700
Closed	00914600002800
Closed	00914600002900
Closed	00914600003000
Closed	00914600003100
Closed	00914600003300
Closed	00914600003200
Closed	00915000000800
Closed	00915000000900
Closed	00915000001000
Closed	00915000001400
Closed	00914900000800
Closed	00914900000900
Closed	00914900002100
Closed	00914900002200
Closed	00914900002300
Closed	00914900003200
Closed	00914900004100
Closed	00914900004200
Closed	00440300000200
Closed	00916400000100
Closed	32053400400100
Closed	00891800007000
Closed	00891800006800
Closed	00891800001600
Closed	00891800001700
Closed	00891700000100
Closed	00891700000700
Closed	00891800010000
Closed	00891800010100
Closed	00891800005600
Closed	00891800005700
Closed	00891800005800
Closed	00891800005900
Closed	00891800006000
Closed	00891800006100
Closed	00891800006200
Closed	00891800006300
Closed	00891800006400
Closed	00891800006500
Closed	00891800006600
Closed	00891700000500
Closed	00891100014500
Closed	00891800000100
Closed	00891800000200
Closed	00891800000300



Accessory Dwelling Units

Index # - File Name: 1.0022 - Single Family Dwellings Data\_Snohomish County.pdf

Closed	00891800000400
Closed	00891800000500
Closed	00891800000600
Closed	00891800000700
Closed	00891800000800
Closed	00891800000900
Closed	00891800001000
Closed	00891800001100
Closed	00891800001200
Closed	00891800001300
Closed	00891800001400
Closed	00891800005000
Closed	00890900006300
Closed	00890900006500
Closed	00890900004000
Closed	00890900005400
Closed	00890900002600
Closed	00890900001500
Closed	00556200001000
Closed	00891100016000
Closed	00891500007500
Closed	00891500007600
Closed	00894900001900
Closed	00894900001700
Closed	00894900002900
Closed	00894900003000
Closed	00894900003100
Closed	00894900003200
Closed	00894900003300
Closed	00894900003400
Closed	00894900003500
Closed	00894900003600
Closed	00894900003700
Closed	00894900003800
Closed	00894900003900
Closed	00894900004000
Closed	00894900004100
Closed	00894900004200
Closed	00894900002300
Closed	00894900002400
Closed	00894900002500
Closed	00894900002600
Closed	00894900002700
Closed	00894900001300
Closed	00894900001400
Closed	00894900000800
Closed	00894900000900

Accessory Dwelling Units

Index # - File Name: 1.0022 - Single Family Dwellings Data\_Snohomish County.pdf

Closed	00894900000400
Closed	00894900000200
Closed	00894800001300
Closed	00894800000800
Closed	00894800000900
Closed	00894800000100
Closed	00894800000200
Closed	00894800000300
Closed	28053200104300
Closed	28053200104400
Closed	00894400000900
Closed	29060400404100
Closed	00894400001900
Closed	00894400003600
Closed	00894400003700
Closed	00894400003800
Closed	00894400003900
Closed	00894400002100
Closed	00894400002200
Closed	00894400002500
Closed	00894400002600
Closed	00894400002700
Closed	00894400002800
Closed	00894400002900
Closed	00894400003000
Closed	00894400003100
Closed	00894400003200
Closed	00894400003300
Closed	00894400003400
Closed	27063400400400
Closed	00894400000600
Closed	00520200006500
Closed	31061700300700
Closed	28071500300200
Closed	27063400200300
Closed	31063000300700
Closed	00893700000200
Closed	00893200002300
Closed	00893200004900
Closed	00893200001200
Closed	00893200001500
Closed	00893200001600
Closed	00893200001700
Closed	00893200001800
Closed	00893200001900
Closed	00893200002000
Closed	00893200002600

Accessory Dwelling Units

Index # - File Name: 1.0022 - Single Family Dwellings Data\_Snohomish County.pdf

Closed	00893200002700
Closed	00893200002800
Closed	00893200002900
Closed	00893200003000
Closed	00893200003100
Closed	00893200003200
Closed	00893200003300
Closed	00893200003400
Closed	00893200003500
Closed	00893200003600
Closed	00893200003700
Closed	00893200003800
Closed	00893200003900
Closed	00893200004000
Closed	00893200004100
Closed	00893200004200
Closed	00893200004300
Closed	00893200004400
Closed	00893200006000
Closed	27051400104600
Closed	27062800202500
Closed	31063000101500
Closed	00891800007200
Closed	00891800007300
Closed	00891800007400
Closed	00891800007500
Closed	00891800007600
Closed	00891800007700
Closed	31063000300400
Closed	00888900000300
Closed	00888900000400
Closed	00888700001500
Closed	27052400303100
Closed	32051400300700
Closed	31042100300600
Closed	30062000200600
Closed	00889000007600
Closed	00889800001400
Closed	00889800000600
Closed	00889800000800
Closed	00889800001700
Closed	00889800001000
Closed	00889800000100
Closed	00891100017600
Closed	00891100017700
Closed	00891100017800
Closed	00891100017900

Accessory Dwelling Units

Index # - File Name: 1.0022 - Single Family Dwellings Data\_Snohomish County.pdf

Closed	00891100016300
Closed	00891100016400
Closed	00891100016500
Closed	00891100016600
Closed	00891100017100
Closed	00891100017200
Closed	00891100017300
Closed	00891100017400
Closed	00891100015800
Closed	00891100015200
Closed	00891100015000
Closed	00891100014700
Closed	00891100014300
Closed	00891100013700
Closed	00891100013900
Closed	00891100014000
Closed	00891100014100
Closed	00891100013100
Closed	00891100012800
Closed	00891100012900
Closed	00891100013300
Closed	00891100011800
Closed	00891100011900
Closed	00891100012000
Closed	00891100012100
Closed	00891100012200
Closed	00891100012300
Closed	00891100012400
Closed	00891100012500
Closed	00891100012600
Closed	00891100009600
Closed	00891100009400
Closed	00891100011300
Closed	00891100006700
Closed	00891100006800
Closed	00891100004800
Closed	00891100006500
Closed	00891100003800
Closed	00891100003100
Closed	00891100003200
Closed	00891100002600
Closed	00891100002700
Closed	00891100000300
Closed	00891100000400
Closed	00891100001500
Closed	00891100001600
Closed	00891100001700

Accessory Dwelling Units

Index # - File Name: 1.0022 - Single Family Dwellings Data\_Snohomish County.pdf

Closed	00891100001800
Closed	00891100001900
Closed	00891100002000
Closed	00891100002100
Closed	00891100002200
Closed	29061500401300
Closed	00890100002200
Closed	00890100001900
Closed	00890100001500
Closed	00890100001700
Closed	00890100000300
Closed	00890100000400
Closed	00890100001200
Closed	00890100001300
Closed	00890100001000
Closed	00885900000100
Closed	00885500001700
Closed	00885500001800
Closed	00466200003600
Closed	30062400402700
Closed	30062400302500
Closed	30062400302400
Closed	00885500004300
Closed	00885500003600
Closed	00886900000200
Closed	00489800000203
Closed	30061900303000
Closed	30061900303100
Closed	27052300200800
Closed	00627300001200
Closed	00886900003300
Closed	00886900003800
Closed	00960014204700
Closed	00960014204800
Closed	00960014204900
Closed	00960014205000
Closed	00960014205100
Closed	30051500201000
Closed	00960014205300
Closed	00960014205400
Closed	00886900005000
Closed	00886900005100
Closed	00886900004100
Closed	00886900004200
Closed	00886900004300
Closed	00886900004700
Closed	00886900004800

Accessory Dwelling Units

Index # - File Name: 1.0022 - Single Family Dwellings Data\_Snohomish County.pdf

Closed	00886900007700
Closed	00886900007800
Closed	00886900005400
Closed	00886900005500
Closed	00886900008000
Closed	00886900008200
Closed	00960014208600
Closed	00960014208700
Closed	00960014208800
Closed	00960014208000
Closed	00960014208200
Closed	00960014208300
Closed	00960014206400
Closed	00960014205900
Closed	00960014207500
Closed	00960014207500
Closed	00960014207700
Closed	00886900010000
Closed	00886900010100
Closed	00886900010300
Closed	00886900009200
Closed	00886900011600
Closed	00960014205700
Closed	00886900012400
Closed	00886900012200
Closed	31042700304200
Closed	00888300002000
Closed	00888300002100
Closed	00887200000100
Closed	31061800203000
Closed	00888300000200
Closed	28072000202000
Closed	28072000202100
Closed	28072000202300
Closed	28072000202400
Closed	00888300002500
Closed	32091000400200
Closed	00373002600311
Closed	31043200300400
Closed	30052900205000
Closed	30052900205100
Closed	30052900205200
Closed	30052900205300
Closed	30052900204600
Closed	30052900204700
Closed	30052900204800
Closed	30052900204900

Accessory Dwelling Units

Index # - File Name: 1.0022 - Single Family Dwellings Data\_Snohomish County.pdf

Closed	28082600400500
Closed	27061900202200
Closed	32051800102100
Closed	28072100302300
Closed	00630600000700
Closed	31051300201100
Closed	00394403906900
Closed	00883500002900
Closed	31051300100900
Closed	28083000201900
Closed	31051300402900
Closed	00884300001500
Closed	00466100000500
Closed	00373002101601
Closed	31041000201900
Closed	00568700500707
Closed	00509500001704
Closed	29070700300500
Closed	00877700000100
Closed	31053200201400
Closed	32080200301500
Closed	00389400300202
Closed	00876200000200
Closed	00876200000300
Closed	30051200403400
Closed	00876200000500
Closed	28083400200700
Closed	29061000400900
Closed	00877100000200
Closed	00457100004108
Closed	00492000203500
Closed	00879300003200
Closed	30081500201800
Closed	28063300200500
Closed	00879300001700
Closed	00879300003300
Closed	00879600000700
Closed	29062300201100
Closed	30063200400600
Closed	00879300002300
Closed	00879300000100
Closed	30060700100400
Closed	31041900100600
Closed	29062300201400
Closed	00403800009702
Closed	27073200100500
Closed	30062500101700

Accessory Dwelling Units

Index # - File Name: 1.0022 - Single Family Dwellings Data\_Snohomish County.pdf

Closed	00880400000700
Closed	27071400100600
Closed	32052100203900
Closed	29063300103000
Closed	30050600302000
Closed	30050600302100
Closed	30050600302300
Closed	32051800201900
Closed	28053600103700
Closed	00409800000700
Closed	27061900304000
Closed	30073100401500
Closed	31063000401600
Closed	32090700100900
Closed	31050500100900
Closed	00893400002900
Closed	00893400003000
Closed	32081200201200
Closed	31060700200100
Closed	00394510201200
Closed	31043100402300
Closed	00590700016800
Closed	00872000000500
Closed	00394401901300
Closed	00597400002502
Closed	29062300105700
Closed	29062300105800
Closed	29062300105800
Closed	29060400101200
Closed	32070900100100
Closed	00373300400202
Closed	00869900003100
Closed	00869900002900
Closed	30060500200300
Closed	00562800002000
Closed	27051500404000
Closed	27061800402400
Closed	27071900102200
Closed	27052100404000
Closed	27062100202600
Closed	27062100300200
Closed	27061800400100
Closed	27051600400800
Closed	27051400100500
Closed	27090900100100
Closed	27090800200800
Closed	27060400102700



Accessory Dwelling Units

Index # - File Name: 1.0022 - Single Family Dwellings Data\_Snohomish County.pdf

Closed	27070800300800
Closed	27090400300100
Closed	27090500101800
Closed	00372800204000
Closed	27063500204800
Closed	27063500302700
Closed	00373000600301
Closed	00373002900905
Closed	00373002203901
Closed	27063100400600
Closed	27043100203100
Closed	27073200400300
Closed	27063400400500
Closed	27062900101000
Closed	27072900400300
Closed	27072900400700
Closed	27063000301100
Closed	27052800103700
Closed	27052800102500
Closed	27052800105400
Closed	27052800302300
Closed	27052400302200
Closed	27052400205800
Closed	27062700301000
Closed	00373700400603
Closed	00376800002800
Closed	00403800008302
Closed	00403900017602
Closed	00403900016403
Closed	00403800004102
Closed	00427100000800
Closed	00427100005900
Closed	00427100006200
Closed	00433100005300
Closed	00460200021900
Closed	00460200017800
Closed	00460100009700
Closed	00460000002900
Closed	00460000006900
Closed	00460100004400
Closed	00624600002500
Closed	00617300100300
Closed	00580100004200
Closed	00577900000500
Closed	00559400005800
Closed	00500100005100
Closed	00512200006600

Accessory Dwelling Units

Index # - File Name: 1.0022 - Single Family Dwellings Data\_Snohomish County.pdf

Closed	00512200004100
Closed	28060400301000
Closed	00526100522400
Closed	28083500402900
Closed	28053600402600
Closed	00374600000705
Closed	28073500101400
Closed	28043400302300
Closed	28063300401500
Closed	28063200403300
Closed	28082900101500
Closed	28062400401900
Closed	28062300403500
Closed	28062200400300
Closed	28061500300900
Closed	28071600104500
Closed	28071200401100
Closed	28071200401700
Closed	28061200202900
Closed	28060900200100
Closed	28070800201000
Closed	28060100100200
Closed	28060400402300
Closed	28060400101000
Closed	00802400000400
Closed	00802400001200
Closed	00802400006500
Closed	00711600001600
Closed	00761200000400
Closed	00761200000500
Closed	00413600000200
Closed	00426800000400
Closed	00570500100402
Closed	00570400102001
Closed	00570400102100
Closed	00552300300801
Closed	00493900001500
Closed	00493900004200
Closed	00574200004900
Closed	00574200001900
Closed	00570500200501
Closed	00574000005300
Closed	00614700500800
Closed	29040100200600
Closed	00784800003400
Closed	00784800003600
Closed	00718000002200

Accessory Dwelling Units

Index # - File Name: 1.0022 - Single Family Dwellings Data\_Snohomish County.pdf

Closed	00729600000300
Closed	00623600000200
Closed	29060400102200
Closed	29060400406200
Closed	29063200100200
Closed	29073200301900
Closed	29063400400600
Closed	29063500301800
Closed	29063500302700
Closed	29062300401900
Closed	30042300301100
Closed	30062200301600
Closed	30062200201500
Closed	30052200301100
Closed	30062100301100
Closed	30062100202800
Closed	30072000300800
Closed	30061900401400
Closed	30051900400500
Closed	30051600307000
Closed	30061700200600
Closed	30061400404800
Closed	30051500202900
Closed	30051500302100
Closed	00828500001900
Closed	30050900402300
Closed	30080900300600
Closed	30061000100400
Closed	30080800401200
Closed	30061300304200
Closed	30050600402900
Closed	00492100005200
Closed	00440200001205
Closed	00441900001200
Closed	00429700000200
Closed	00431400200608
Closed	00385600201200
Closed	00385600501000
Closed	00393800001900
Closed	00607100001600
Closed	00597300000307
Closed	00543500000601
Closed	00580900001601
Closed	30040200102400
Closed	00630300001700
Closed	00630300001800
Closed	00630300001900

Accessory Dwelling Units

Index # - File Name: 1.0022 - Single Family Dwellings Data\_Snohomish County.pdf

Closed	00630300002000
Closed	00630300002100
Closed	00630300002200
Closed	00630300002300
Closed	00630300002400
Closed	00630800002000
Closed	00736500001200
Closed	00631600007700
Closed	00622300000800
Closed	00622300001300
Closed	00582600200700
Closed	00582600300100
Closed	00557600003101
Closed	00590700009000
Closed	00590600000400
Closed	00600600000300
Closed	00600700000800
Closed	32061000202500
Closed	00557300201500
Closed	00551500005800
Closed	00551500005900
Closed	00551500006000
Closed	00551500004000
Closed	00543800002900
Closed	00543300009000
Closed	00543300006400
Closed	00511000010000
Closed	00511000004700
Closed	00532000002701
Closed	00489100013000
Closed	00480000012000
Closed	30063600201800
Closed	00828500004000
Closed	30053100200800
Closed	30063200404400
Closed	30063200401700
Closed	31042200401100
Closed	31052400202800
Closed	31041800401900
Closed	31051900101900
Closed	31041400300600
Closed	31041500400300
Closed	31041500401000
Closed	31050700300400
Closed	31060600200400
Closed	31050900200100
Closed	31050400101400

Accessory Dwelling Units

Index # - File Name: 1.0022 - Single Family Dwellings Data\_Snohomish County.pdf

Closed	31040400300300
Closed	31050400100300
Closed	31040400400100
Closed	31040500102000
Closed	31050500201100
Closed	31063300301700
Closed	31043400100900
Closed	31043500404200
Closed	00384300002800
Closed	00384000002100
Closed	31043600401200
Closed	31062900100700
Closed	31062800301000
Closed	31063000201900
Closed	31062900403500
Closed	31063000100800
Closed	00394510800700
Closed	00394510601200
Closed	00394511000502
Closed	00394406100800
Closed	00394403200300
Closed	00394401902100
Closed	00394406600400
Closed	00394509000901
Closed	00394507101302
Closed	00394509000400
Closed	32052900400100
Closed	32052900400400
Closed	32053200303900
Closed	32052700101200
Closed	32042100400200
Closed	32051900401900
Closed	32041600102300
Closed	32041000302900
Closed	32041000302400
Closed	32041300101000
Closed	32090700402100
Closed	32050900200900
Closed	32090800300600
Closed	32040700100300
Closed	32080700201500
Closed	00630700001200
Closed	00630700001300
Closed	32060300301300
Closed	32040300400300
Closed	00499100201800
Closed	00546900005201

Accessory Dwelling Units

Index # - File Name: 1.0022 - Single Family Dwellings Data\_Snohomish County.pdf

Closed	00489700305000
Closed	00489700301400
Closed	00494600100404
Closed	00494600200108
Closed	29061200300900
Closed	30061700400600
Closed	30061000401700
Closed	28060300300800
Closed	30062400301400
Closed	30040100100100
Closed	29060100202800
Closed	32063600101900
Closed	32063600102000
Closed	00489100002000
Closed	32081100200700
Closed	28061500400100
Closed	27051100409800
Closed	30063600101400
Closed	00376800000600
Closed	28061500101500
Closed	27071800402100
Closed	27071800402200
Closed	30061800301200
Closed	32091100100300
Closed	31040900201100
Closed	31040900100500
Closed	30063200403000
Closed	00513100000203
Closed	00836500003500
Closed	00836500005500
Closed	00836500004900
Closed	32071900100400
Closed	32071900100400
Closed	00629300001500
Closed	27062600400900
Closed	00589600005300
Closed	00587200002300
Closed	00543200001602
Closed	00490100002700
Closed	00490100006400
Closed	00490300000900
Closed	00490400001200
Closed	32053300102100
Closed	32043300200500
Closed	32063200400300
Closed	32063600101400
Closed	32063500201200

Accessory Dwelling Units

Index # - File Name: 1.0022 - Single Family Dwellings Data\_Snohomish County.pdf

Closed	27062800400300
Closed	29061100400900
Closed	00629600004800
Closed	00637400000500
Closed	27073100201500
Closed	28061400202900
Closed	00389400200300
Closed	00389400200104
Closed	00813000000900
Closed	27043600301300
Closed	31041000201000
Closed	27071100101000
Closed	00823300013700
Closed	00823300012800
Closed	00823300012900
Closed	00823300013000
Closed	32041400302600
Closed	32061700100200
Closed	28073400304800
Closed	00823300000200
Closed	31042000300200
Closed	28071500400100
Closed	28082100401100
Closed	30063100205200
Closed	30042300301600
Closed	31040900300200
Closed	00577700501200
Closed	28060900203200
Closed	30072000401400
Closed	00401000010100
Closed	32060400400700
Closed	31062900402500
Closed	00594000002100
Closed	00836000000600
Closed	28070500300600
Closed	00597400001402
Closed	30061100401400
Closed	27051100409700
Closed	27063400201000
Closed	30060500403100
Closed	30060300301000
Closed	30060500102100
Closed	30060500101800
Closed	30060500100800
Closed	30060500100700
Closed	31043400404200
Closed	00860400000300

Accessory Dwelling Units

Index # - File Name: 1.0022 - Single Family Dwellings Data\_Snohomish County.pdf

Closed	00860400000400
Closed	00860400000500
Closed	00860400000600
Closed	00860400000700
Closed	00860400000800
Closed	00858200000300
Closed	00858200000500
Closed	30060900300600
Closed	30060900300800
Closed	30060900300900
Closed	30060900301000
Closed	30060900301100
Closed	30060900301200
Closed	00457100004106
Closed	00862100001100
Closed	28071900200600
Closed	00850200000800
Closed	00850200001000
Closed	30060500301500
Closed	00489800000603
Closed	30060500301000
Closed	30060500301100
Closed	30060500301200
Closed	00852800001500
Closed	00804600000100
Closed	00492800002600
Closed	27071300200900
Closed	00853600000400
Closed	00853600002800
Closed	00403900022602
Closed	31062000101800
Closed	29061500101000
Closed	31052300302400
Closed	00403900016006
Closed	00617700000201
Closed	27070200301400
Closed	27070200301300
Closed	00403900016004
Closed	00489100003100
Closed	00394401800100
Closed	00513100004103
Closed	28050300404500
Closed	31042000400500
Closed	29051100103100
Closed	27063400300400
Closed	00802400006800
Closed	31050500201400



Accessory Dwelling Units

Index # - File Name: 1.0022 - Single Family Dwellings Data\_Snohomish County.pdf

Closed	31043500400800
Closed	32053300400300
Closed	31040800302300
Closed	30060800102900
Closed	31052400200300
Closed	00850200000700
Closed	00849400000500
Closed	30060500402300
Closed	30060500402400
Closed	31040300300700
Closed	30060500401700
Closed	27052600402000
Closed	28050200305200
Closed	00394510201100
Closed	29063200200900
Closed	30061800102000
Closed	00473300003403
Closed	28061000201700
Closed	00858200000800
Closed	00858200000900
Closed	00858400001100
Closed	00860400000100
Closed	00860400000200
Closed	00505100000400
Closed	30060500403200
Closed	00597500000907
Closed	00394404401200
Closed	00394404401500
Closed	00394404402100
Closed	00394404407100
Closed	00394404406500
Closed	30073000300500
Closed	27052800410000
Closed	00493401400101
Closed	27073000200700
Closed	00374800002100
Closed	32041800201300
Closed	00835200000200
Closed	32041000101900
Closed	00608100100404
Closed	28070300300500
Closed	29051100102900
Closed	00394509100202
Closed	29061400203300
Closed	00831300001200
Closed	00831300000800
Closed	31063000200700

Accessory Dwelling Units

Index # - File Name: 1.0022 - Single Family Dwellings Data\_Snohomish County.pdf

Closed	30061000200500
Closed	27102000100200
Closed	00817000000200
Closed	00597400001503
Closed	00512000212800
Closed	30042300401500
Closed	00823700000900
Closed	00823700001000
Closed	00512000205900
Closed	28073200403500
Closed	28073200403400
Closed	28073200403200
Closed	28073200403700
Closed	28073200403600
Closed	28073200303200
Closed	28073200303100
Closed	28073200303300
Closed	28073200303500
Closed	28073200303400
Closed	00389400200200
Closed	28062500301400
Closed	00569000005601
Closed	00394510200200
Closed	00569000001001
Closed	32063500400600
Closed	32043600400800
Closed	32063200301400
Closed	32063200200800
Closed	32063200202000
Closed	32053300200200
Closed	00490300001200
Closed	00589600010000
Closed	00589600000400
Closed	00589600000900
Closed	00587200004800
Closed	00590700015200
Closed	00836500000500
Closed	32071900100400
Closed	31063000100200
Closed	30063200403000
Closed	27071300100100
Closed	00401100007900
Closed	27071800401600
Closed	27101900401700
Closed	29061100100300
Closed	27051600405300
Closed	29062000404900

Accessory Dwelling Units

Index # - File Name: 1.0022 - Single Family Dwellings Data\_Snohomish County.pdf

Closed	27070200101600
Closed	30062400301500
Closed	30062400301300
Closed	28071200400500
Closed	00466400001600
Closed	00494600100107
Closed	00494600200904
Closed	00494511501201
Closed	00485300000400
Closed	00490600000702
Closed	00609100003200
Closed	00609700002600
Closed	00609700002700
Closed	00494600300901
Closed	00537400001000
Closed	00537400001300
Closed	00499100201000
Closed	00499100201800
Closed	32040300300900
Closed	32040300301700
Closed	32060300301400
Closed	00701100000800
Closed	32080200101000
Closed	00659800000700
Closed	32050700300100
Closed	32040600200600
Closed	32080800100900
Closed	32040800300600
Closed	32081300101000
Closed	32060900101800
Closed	32041000102200
Closed	32041600102500
Closed	32051400302300
Closed	32051900202000
Closed	32051900100900
Closed	32052400200400
Closed	32052200303200
Closed	32062100301900
Closed	32062100101200
Closed	32062900103800
Closed	00394406200900
Closed	00394402200100
Closed	00394402601300
Closed	00394406200600
Closed	00394406200601
Closed	00417900002600
Closed	31062900102600

Accessory Dwelling Units

Index # - File Name: 1.0022 - Single Family Dwellings Data\_Snohomish County.pdf

Closed	31062900201300
Closed	31062800301500
Closed	31042700200800
Closed	31052600101000
Closed	31060600200300
Closed	31060400402500
Closed	31040400401200
Closed	31050400302600
Closed	31040300302300
Closed	31050300201500
Closed	31060600402700
Closed	31040800200100
Closed	31041800400800
Closed	31052400301700
Closed	31042300402400
Closed	31042300405300
Closed	31042600401300
Closed	31042600201900
Closed	30073100401400
Closed	30063200200800
Closed	30062900400900
Closed	30062900101300
Closed	30052500400400
Closed	00385300001300
Closed	00401000004100
Closed	00401100006000
Closed	00401000006600
Closed	00401000010200
Closed	00401000010300
Closed	00401000010400
Closed	00401000010500
Closed	00406400003100
Closed	00480000012000
Closed	00471300001700
Closed	00429900002000
Closed	00444800002000
Closed	00406400001000
Closed	00511000005200
Closed	00551500004400
Closed	00551500004500
Closed	00551500006100
Closed	00551500006300
Closed	00551500006400
Closed	00551500006500
Closed	00551400002900
Closed	00557300103900
Closed	00557200402300

Accessory Dwelling Units

Index # - File Name: 1.0022 - Single Family Dwellings Data\_Snohomish County.pdf

Closed	00554300004200
Closed	00560400004401
Closed	00622300002900
Closed	00617400003100
Closed	00629100001000
Closed	00625300003402
Closed	00611300007000
Closed	00647500001400
Closed	30040200102300
Closed	00625900003700
Closed	00516700010100
Closed	00516700010200
Closed	00516700010300
Closed	00533400001200
Closed	00457100003203
Closed	00457100003805
Closed	00492000300100
Closed	00516700008500
Closed	00492000107200
Closed	00491900500600
Closed	00471400000300
Closed	00476200100119
Closed	00491900101200
Closed	30060400102400
Closed	30060400400400
Closed	30050500200100
Closed	30040300400300
Closed	30040300200800
Closed	30051300202400
Closed	30051200300100
Closed	30061200402000
Closed	30080800302800
Closed	30060800400500
Closed	00828500002600
Closed	30052000300400
Closed	30062100202600
Closed	30042300201100
Closed	29062400300200
Closed	29062300101600
Closed	29063500303900
Closed	29063500101100
Closed	29063400200500
Closed	29073200301800
Closed	29060400402200
Closed	29051200406800
Closed	29061200300200
Closed	29061400201300

Accessory Dwelling Units

Index # - File Name: 1.0022 - Single Family Dwellings Data\_Snohomish County.pdf

Closed	00747900005100
Closed	29060100201600
Closed	00574100005400
Closed	00573800002700
Closed	00552300300701
Closed	00526800000400
Closed	00373002303202
Closed	00569000000202
Closed	00568900001002
Closed	00473300500101
Closed	00396500009400
Closed	28050300403400
Closed	28050100304300
Closed	28050100304400
Closed	28071000300900
Closed	28061100203200
Closed	28071600106900
Closed	28071900401100
Closed	28072000102000
Closed	28061400303800
Closed	28051600203900
Closed	28062300300500
Closed	28062500100500
Closed	28082800203100
Closed	28082800301800
Closed	28093200301300
Closed	28093100301600
Closed	00380900102401
Closed	28073600101100
Closed	28053600300500
Closed	28073500205300
Closed	00513700003502
Closed	00513700003501
Closed	00513800009405
Closed	00513700004710
Closed	00526100503900
Closed	00500100003600
Closed	00464100000301
Closed	00556600010700
Closed	00609600000103
Closed	00583000000100
Closed	00583000000500
Closed	00617300201001
Closed	00621200000500
Closed	00630000001400
Closed	00631900000400
Closed	00460100007100

Accessory Dwelling Units

Index # - File Name: 1.0022 - Single Family Dwellings Data\_Snohomish County.pdf

Closed	00460100006400
Closed	00460000007200
Closed	00433100001800
Closed	00427100007800
Closed	00427100007000
Closed	00422800002100
Closed	00416800001000
Closed	00403800012301
Closed	00403900024704
Closed	00373700401102
Closed	00373003100404
Closed	27052300202900
Closed	27062200402300
Closed	27052200101300
Closed	27052800206900
Closed	27063300102000
Closed	27063200102400
Closed	00373002302204
Closed	00373000301804
Closed	27060600200400
Closed	27050200302900
Closed	27061600201600
Closed	27090900300300
Closed	27051000303900
Closed	27051500200700
Closed	27051500100900
Closed	27051400200600
Closed	27071300200800
Closed	27051600402400
Closed	27051600400700
Closed	27061700101000
Closed	27061600401200
Closed	27061900402600
Closed	27071800104800
Closed	27051500404000
Closed	30052200304700
Closed	00869300000200
Closed	00869300000300
Closed	00489100009800
Closed	28063300200200
Closed	27051100306600
Closed	00597500000905
Closed	00867600004200
Closed	29060200303700
Closed	30061400200100
Closed	30061800402300
Closed	00960010205200

Accessory Dwelling Units

Index # - File Name: 1.0022 - Single Family Dwellings Data\_Snohomish County.pdf

Closed	00868400002400
Closed	00868400001000
Closed	29060300402400
Closed	29060300401800
Closed	29060200304000
Closed	31042000400700
Closed	31042600300400
Closed	00394401901500
Closed	29061400101900
Closed	00597400000205
Closed	00590700024305
Closed	31043100402200
Closed	00582500600100
Closed	29040900301000
Closed	30040800101000
Closed	27052100405400
Closed	28072000301100
Closed	00893400002700
Closed	00880400001400
Closed	30062500202100
Closed	28053600105200
Closed	28053600105000
Closed	30072800201600
Closed	29061900200700
Closed	30052200304800
Closed	28050200104400
Closed	00879300002400
Closed	00879300001600
Closed	00879300002100
Closed	00879300000400
Closed	00879600000800
Closed	00879600000300
Closed	00876800000600
Closed	27051400302900
Closed	00394403200202
Closed	27051400107200
Closed	00878100202200
Closed	30060700202600
Closed	00466900001700
Closed	30040300303200
Closed	32071200100600
Closed	27062000102800
Closed	27051600300200
Closed	29052600206900
Closed	29052600207300
Closed	31043500401500
Closed	00587400000801



Accessory Dwelling Units

Index # - File Name: 1.0022 - Single Family Dwellings Data\_Snohomish County.pdf

Closed	00587400000802
Closed	31063400402000
Closed	32063300304400
Closed	29072600100700
Closed	28073000202700
Closed	00887200000300
Closed	32053300203300
Closed	00886900010900
Closed	28083000301000
Closed	00886900004000
Closed	29051100400700
Closed	30061900302800
Closed	32070900200400
Closed	00885500002200
Closed	00885500004000
Closed	00885500002900
Closed	00885500004500
Closed	00885500004600
Closed	00885500004700
Closed	00885500005000
Closed	00885500005700
Closed	30062400302300
Closed	00885500000100
Closed	00885500000200
Closed	00885500000300
Closed	00885500000400
Closed	28050100204100
Closed	00885500001900
Closed	00885500002400
Closed	32040400301800
Closed	00890100001400
Closed	32041500302700
Closed	00891100000100
Closed	00891100002800
Closed	00891100002900
Closed	00891100003000
Closed	00891100003900
Closed	00891100003600
Closed	00891100011200
Closed	00891100009000
Closed	00891100009100
Closed	00891100009200
Closed	00891100009300
Closed	00891100006900
Closed	00891100007000
Closed	00891100007100
Closed	00891100013500

Accessory Dwelling Units

Index # - File Name: 1.0022 - Single Family Dwellings Data\_Snohomish County.pdf

Closed	00891100013600
Closed	00891100013200
Closed	00891100014200
Closed	00891100014400
Closed	28062300402200
Closed	00889800000500
Closed	00889800001100
Closed	00889800001200
Closed	00889800001300
Closed	00889800000900
Closed	27063400402800
Closed	28062800302100
Closed	30062000400200
Closed	00373000301704
Closed	00516700010400
Closed	27051000406400
Closed	00375000006700
Closed	27062800203400
Closed	00401000006700
Closed	00893200002100
Closed	00893200002200
Closed	00893200002400
Closed	30042100101800
Closed	00894400001400
Closed	00894400002300
Closed	27090500400200
Closed	28073500100700
Closed	00891100016100
Closed	00891800005200
Closed	00891800005300
Closed	00890900002200
Closed	00890900003600
Closed	00890900003700
Closed	00890900003200
Closed	00890900005500
Closed	00890900005600
Closed	00890900005700
Closed	00890900005800
Closed	00890900005900
Closed	00891800005400
Closed	00890900004300
Closed	00890900006600
Closed	00890900006400
Closed	00890900006100
Closed	00890900006200
Closed	00890900005100
Closed	32053100404000

Accessory Dwelling Units

Index # - File Name: 1.0022 - Single Family Dwellings Data\_Snohomish County.pdf

Closed	31042700305200
Closed	32090800400400
Closed	00401100015100
Closed	00921600000100
Closed	00921600002900
Closed	00921600000200
Closed	00921600000300
Closed	00921600000400
Closed	00921600000500
Closed	00921600000600
Closed	00921600000800
Closed	00921600001100
Closed	00921600001200
Closed	00921600001300
Closed	00921600001400
Closed	00921600001500
Closed	00921600001600
Closed	00921600001800
Closed	00921600001900
Closed	00921600002000
Closed	00921600002100
Closed	00921600002200
Closed	00921600002300
Closed	00921600002400
Closed	00921600002500
Closed	00921600002600
Closed	00921600002700
Closed	00921600002800
Closed	00919900000701
Closed	32040400301000
Closed	00919900007001
Closed	00919900007401
Closed	00919900009801
Closed	00919900009901
Closed	00919900010001
Closed	00927100000400
Closed	00927100000500
Closed	00927100000600
Closed	00927100000700
Closed	00927100000800
Closed	00927100000900
Closed	00927100001000
Closed	00927100001100
Closed	00927100001200
Closed	00927100001300
Closed	00927100001400
Closed	00927100001500

Accessory Dwelling Units

Index # - File Name: 1.0022 - Single Family Dwellings Data\_Snohomish County.pdf

Closed	00927100001700
Closed	00927100001800
Closed	00927100001900
Closed	00927100003900
Closed	00927100003800
Closed	00927100003700
Closed	00927100004000
Closed	00927100003600
Closed	00927100004100
Closed	00927100003500
Closed	00927100003400
Closed	00927100003300
Closed	00927100003200
Closed	00927100003100
Closed	00927100003000
Closed	00927100004200
Closed	00927100002900
Closed	00927100004300
Closed	00927100002800
Closed	00927100004400
Closed	00927100002700
Closed	00927100004500
Closed	00927100002600
Closed	00927100004600
Closed	00927100002500
Closed	00927100002400
Closed	00927100002000
Closed	00927100002100
Closed	00927100002200
Closed	00927100002300
Closed	30052200209000
Closed	00919900000801
Closed	00919900000901
Closed	00919900001001
Closed	00919900001101
Closed	00919900001201
Closed	00919900001301
Closed	00919900001401
Closed	00919900001501
Closed	00919900001601
Closed	00919900001701
Closed	00919900001801
Closed	00919900001901
Closed	00919900002001
Closed	00919900002101
Closed	00919900002201
Closed	00919900002901

Accessory Dwelling Units

Index # - File Name: 1.0022 - Single Family Dwellings Data\_Snohomish County.pdf

Closed	00919900003001
Closed	00919900003101
Closed	00919900003201
Closed	00919900002301
Closed	00919900002401
Closed	00919900002501
Closed	00919900002601
Closed	00919900002701
Closed	00919900002801
Closed	00919100000200
Closed	00919900003401
Closed	00919900003501
Closed	00919900003701
Closed	00919900003801
Closed	00919900003901
Closed	00919900004001
Closed	00919900004101
Closed	00919900004301
Closed	00919900004901
Closed	00919900004801
Closed	00919900004701
Closed	00919900004601
Closed	00919900004501
Closed	00919900004401
Closed	00919900008601
Closed	00919900008501
Closed	00919900007901
Closed	00919900007801
Closed	00919900005401
Closed	00919900005301
Closed	00919900005101
Closed	00919900007201
Closed	00919900007701
Closed	00919900008001
Closed	00919900008101
Closed	00919900008201
Closed	00919900008301
Closed	00919900008401
Closed	00919900008701
Closed	00919900008801
Closed	00919900008901
Closed	00919900009001
Closed	00919900009101
Closed	00919900009201
Closed	00919900009301
Closed	00919900009401
Closed	00919900009701

Accessory Dwelling Units

Index # - File Name: 1.0022 - Single Family Dwellings Data\_Snohomish County.pdf

Closed	31051900303900
Closed	00617300100101
Closed	00617300100201
Closed	31040700402700
Closed	31043500401600
Closed	27051500106700
Closed	30063300304600
Closed	28052800205400
Closed	28052800205500
Closed	28052800205600
Closed	00617300101101
Closed	28052900101900
Closed	28052900102100
Closed	00921700000100
Closed	00921700000200
Closed	00921700000300
Closed	00921700000400
Closed	00921700000500
Closed	00921700000600
Closed	00922600000100
Closed	00922600000200
Closed	00922600000300
Closed	00922600000400
Closed	00922600000500
Closed	00922600000600
Closed	00922600000700
Closed	00922600000800
Closed	00922600000900
Closed	00494511300902
Closed	00529800001400
Closed	00922500000900
Closed	00922500001000
Closed	00922500001100
Closed	00922500001200
Closed	00922500001300
Closed	00922500001400
Closed	00922500001500
Closed	00922500001600
Closed	00922500001700
Closed	00922500001800
Closed	00922500002000
Closed	00922800000100
Closed	00922800000200
Closed	00922800000300
Closed	00922800000400
Closed	00922800000500
Closed	00922800000700

Accessory Dwelling Units

Index # - File Name: 1.0022 - Single Family Dwellings Data\_Snohomish County.pdf

Closed	00922800000800
Closed	00922800000900
Closed	00922800001000
Closed	00626200000500
Closed	00626200000400
Closed	00922500001900
Closed	00494511300901
Closed	00600300300400
Closed	00923500000100
Closed	00923500000200
Closed	00923500000300
Closed	00923500000400
Closed	00923500000500
Closed	00923500000600
Closed	00923500000700
Closed	00923500000800
Closed	00923500000900
Closed	00923500001000
Closed	00923500001100
Closed	00923500001300
Closed	00923500001400
Closed	00923500001500
Closed	00923500001600
Closed	27073000200900
Closed	00373002800606
Closed	00373002800605
Closed	27090400101800
Closed	00924300000500
Closed	00494511301000
Closed	00924300001100
Closed	31043100300500
Closed	30040800400800
Closed	00926600000700
Closed	00926600000800
Closed	00926600001200
Closed	00924500000500
Closed	00924500000600
Closed	00924500000700
Closed	00924500000800
Closed	00924500001100
Closed	00924500001200
Closed	00924500001300
Closed	00924500001400
Closed	00924500001500
Closed	00924500001600
Closed	00924500003800
Closed	00924500003900

Accessory Dwelling Units

Index # - File Name: 1.0022 - Single Family Dwellings Data\_Snohomish County.pdf

Closed	0092450000200
Closed	0092450000300
Closed	00904000003500
Closed	00923900000100
Closed	00923900000200
Closed	00923900000400
Closed	30042400202500
Closed	30042400102800
Closed	32063200403900
Closed	27051400400200
Closed	29060400201500
Closed	00924000000100
Closed	00924000000200
Closed	00924000000700
Closed	00924000000800
Closed	00924000000900
Closed	00924000001400
Closed	00924000001500
Closed	00924000001600
Closed	00924400000100
Closed	00924400000200
Closed	00924400000300
Closed	00924400000400
Closed	00924400001500
Closed	00924400001600
Closed	00924400001700
Closed	00924400001800
Closed	00926300000200
Closed	00926300000300
Closed	00926300000400
Closed	00926300000900
Closed	00926300001000
Closed	00926300001100
Closed	00926300000100
Closed	00926400000100
Closed	00926400000200
Closed	00926400000300
Closed	00926400000400
Closed	00926400000500
Closed	00926400000600
Closed	00926400001500
Closed	00926400001600
Closed	00926400001700
Closed	00926400001800
Closed	00926400001900
Closed	00926400002000
Closed	00926400002100



Accessory Dwelling Units

Index # - File Name: 1.0022 - Single Family Dwellings Data\_Snohomish County.pdf

Closed	00926100000500
Closed	00926100000600
Closed	00926400002600
Closed	00926400002700
Closed	00926400003300
Closed	00926400003400
Closed	00926400004600
Closed	00926400004700
Closed	00926400004800
Closed	00926400004900
Closed	00926400005000
Closed	00926400005100
Closed	00926400005200
Closed	28070700401500
Closed	00926100000200
Closed	00926400003000
Closed	00926500000600
Closed	00589600003900
Closed	00499100100900
Closed	00385700800403
Closed	00385700800301
Closed	00926900000100
Closed	00926900000200
Closed	00926900000300
Closed	00926900000400
Closed	00960002204600
Closed	00373700402801
Closed	00538000014305
Closed	00373100200506
Closed	00373100200505
Closed	29060200100100
Closed	32052100100500
Closed	00933900000500
Closed	00933900000600
Closed	00933900000700
Closed	00933900000800
Closed	00933900003100
Closed	00933900003200
Closed	00933900003300
Closed	00933900001500
Closed	00933900001600
Closed	31043300300100
Closed	00927000000100
Closed	00927000000200
Closed	00927000000300
Closed	00927000000800
Closed	00927000000400

Accessory Dwelling Units

Index # - File Name: 1.0022 - Single Family Dwellings Data\_Snohomish County.pdf

Closed	00927000000500
Closed	00927000000600
Closed	00927000000700
Closed	00927000000900
Closed	00933900001000
Closed	00933900001100
Closed	00933900001200
Closed	27041100403100
Closed	27041100403200
Closed	27041100403300
Closed	27041100403400
Closed	00933900002800
Closed	00927700000400
Closed	00927700001100
Closed	00927700001200
Closed	00927700001500
Closed	00927700000200
Closed	00794600002900
Closed	00927800001900
Closed	32063000402400
Closed	32063000402500
Closed	00927800001400
Closed	00928600000200
Closed	00928600000300
Closed	00928600000400
Closed	00928600000500
Closed	00928600000600
Closed	00928600000700
Closed	00928600005600
Closed	00928600005700
Closed	00928600005800
Closed	00928600006000
Closed	00928600006100
Closed	00928600006200
Closed	00928600005900
Closed	00928600000800
Closed	00928200007700
Closed	00928200007800
Closed	00928200007900
Closed	00928200008000
Closed	00928200009600
Closed	00928600000100
Closed	00928200007400
Closed	00928200007500
Closed	00928200010900
Closed	00928200010600
Closed	00928200006100

Accessory Dwelling Units

Index # - File Name: 1.0022 - Single Family Dwellings Data\_Snohomish County.pdf

Closed	00928200006000
Closed	00928200007100
Closed	00928200007000
Closed	00928200006900
Closed	00928200006800
Closed	00928200006700
Closed	00928200006600
Closed	00928200006500
Closed	00928200006400
Closed	00928200006300
Closed	32100800300100
Closed	30063500102500
Closed	00394401808200
Closed	00432700000101
Closed	00556800101201
Closed	00794000001200
Closed	00513700004105
Closed	00929100000200
Closed	00929100000300
Closed	00929100000400
Closed	00929100000500
Closed	00929100000600
Closed	00929100000700
Closed	00929100000800
Closed	00929100007300
Closed	00929100005500
Closed	00929100005600
Closed	00929100005700
Closed	00929100007200
Closed	00929100009200
Closed	00929100005100
Closed	00929100005300
Closed	00929100008800
Closed	00929100008900
Closed	00929100009100
Closed	00929100000100
Closed	00929600000300
Closed	00929600001100
Closed	00929600000600
Closed	00929600001600
Closed	00929600001700
Closed	00929600002100
Closed	00929600002200
Closed	00929600002300
Closed	00929600002400
Closed	00929900000400
Closed	00929600001900

Accessory Dwelling Units

Index # - File Name: 1.0022 - Single Family Dwellings Data\_Snohomish County.pdf

Closed	00929600003100
Closed	00929600003600
Closed	00929600003700
Closed	00929900000200
Closed	28071600103700
Closed	32053300102700
Closed	00916400000300
Closed	00916400000400
Closed	00916400000500
Closed	00916400000600
Closed	00916400000700
Closed	00916400000800
Closed	00916400000900
Closed	00916400001000
Closed	00916400001100
Closed	00916400001200
Closed	00916300000200
Closed	00916300000300
Closed	00916300000400
Closed	00916300000500
Closed	00916300000600
Closed	00916300000700
Closed	00916300000800
Closed	00916300000900
Closed	00916300001000
Closed	00916500001700
Closed	00916500001800
Closed	00916500001900
Closed	00916500002000
Closed	00916500002100
Closed	00916500002200
Closed	00916500002300
Closed	00916500002400
Closed	00916500002500
Closed	00916500002600
Closed	00916500002700
Closed	00916500002800
Closed	00916500001400
Closed	00916500001500
Closed	00916500001600
Closed	00629300000700
Closed	00916400000200
Closed	00916400001600
Closed	00916400001700
Closed	00916400001800
Closed	00916400001900
Closed	00916400002000

Accessory Dwelling Units

Index # - File Name: 1.0022 - Single Family Dwellings Data\_Snohomish County.pdf

Closed	00916400002100
Closed	00916400002200
Closed	00373000300111
Closed	00512200004700
Closed	00403800014401
Closed	00480401501100
Closed	00466700002600
Closed	00916900000500
Closed	00916900000600
Closed	00916900000700
Closed	00916900000800
Closed	00916900001500
Closed	00916900001600
Closed	00414300001702
Closed	00914900004300
Closed	00914900003300
Closed	00914900003400
Closed	00914900003500
Closed	00914900003600
Closed	00914900003700
Closed	00914900003800
Closed	00914900003900
Closed	00914900004000
Closed	00914900002400
Closed	00914900002500
Closed	00914900002600
Closed	00914900002700
Closed	00914900002800
Closed	00914900002900
Closed	00914900003000
Closed	00914900003100
Closed	00914900001000
Closed	00914900001100
Closed	00914900001200
Closed	00914900001300
Closed	00914900001400
Closed	00914900001500
Closed	00914900001600
Closed	00914900001700
Closed	00914900001800
Closed	00914900001900
Closed	00914900002000
Closed	32051800102500
Closed	00466700000300
Closed	00466700004800
Closed	30060600301700
Closed	00433100001001

Accessory Dwelling Units

Index # - File Name: 1.0022 - Single Family Dwellings Data\_Snohomish County.pdf

Closed	00374600001401
Closed	00374600001402
Closed	00916500000200
Closed	00916500000400
Closed	00916500000500
Closed	00916500001100
Closed	00916500001200
Closed	00916500001300
Closed	00916500004200
Closed	00916500004100
Closed	00916500004000
Closed	00916500003900
Closed	00916500003800
Closed	00916500003700
Closed	00916500003600
Closed	00916500003500
Closed	00916500003400
Closed	00916500003300
Closed	00916500003200
Closed	00916500003100
Closed	00916500003000
Closed	00916500002900
Closed	00916500004400
Closed	00916500001000
Closed	00916500000800
Closed	00915000001500
Closed	00916500000600
Closed	00914900000100
Closed	00914900000200
Closed	00914900000300
Closed	00914900000400
Closed	00914900000500
Closed	00914900000600
Closed	00914900000700
Closed	00915000001100
Closed	00915000001200
Closed	00915000001300
Closed	00915000000400
Closed	00915000000500
Closed	00915000000600
Closed	00915000000700
Closed	00915000001600
Closed	00915000001700
Closed	00915000001800
Closed	00915000002000
Closed	28060200202000
Closed	00914700201600

Accessory Dwelling Units

Index # - File Name: 1.0022 - Single Family Dwellings Data\_Snohomish County.pdf

Closed	00914700201700
Closed	00914100001400
Closed	00914100001500
Closed	00921100100100
Closed	00914700201300
Closed	00914700201900
Closed	00914700202000
Closed	00914700202100
Closed	00914700202300
Closed	00914700202400
Closed	00914700202500
Closed	00914600000100
Closed	00914600000200
Closed	00914600000300
Closed	00914600000400
Closed	00914600000500
Closed	00914600000600
Closed	00914600000700
Closed	00914600000800
Closed	00914600000900
Closed	00914600001000
Closed	00914600001100
Closed	00914600001200
Closed	00914600001300
Closed	00914600001400
Closed	00914600001500
Closed	00914600001700
Closed	00914600001800
Closed	00914600001900
Closed	00914600002000
Closed	00914600002100
Closed	00914600002200
Closed	00914600002300
Closed	00914600002400
Closed	00914600002500
Closed	00914700100300
Closed	00914700100400
Closed	00914700200600
Closed	00914700200700
Closed	00914700200800
Closed	00914700200900
Closed	00914700201000
Closed	00914700201100
Closed	00914700100600
Closed	00914700100700
Closed	00914700101000
Closed	00914700200100

Accessory Dwelling Units

Index # - File Name: 1.0022 - Single Family Dwellings Data\_Snohomish County.pdf

Closed	00914700200200
Closed	00914700200300
Closed	00914700200400
Closed	00914000004400
Closed	00914000005000
Closed	00914000005400
Closed	00914000005100
Closed	00914000005200
Closed	00914100000300
Closed	00914100000400
Closed	00914100000500
Closed	00914100000900
Closed	00409500000100
Closed	31060300200800
Closed	30073100300100
Closed	28073300202800
Closed	00914000001500
Closed	00914000005600
Closed	00914000001800
Closed	00914000001900
Closed	00914000002000
Closed	00914000002100
Closed	00914000002200
Closed	00914000002300
Closed	00914000002400
Closed	00914000002500
Closed	00914000002600
Closed	00914000002800
Closed	00914000002900
Closed	00914000003000
Closed	00914000003100
Closed	00914000003300
Closed	00914000003400
Closed	00914000003500
Closed	00914000003700
Closed	00914000004100
Closed	00913600000500
Closed	00913600000600
Closed	00913600000700
Closed	00913600000800
Closed	00913600000900
Closed	00913600001000
Closed	00913600001100
Closed	00913600001200
Closed	00913600001300
Closed	31041400300400
Closed	00913600001400



Accessory Dwelling Units

Index # - File Name: 1.0022 - Single Family Dwellings Data\_Snohomish County.pdf

Closed	27061700203100
Closed	00913400002300
Closed	00913400001000
Closed	00913400001100
Closed	00913400001500
Closed	00913400002200
Closed	00913400000300
Closed	00913400000400
Closed	00913400001900
Closed	00913100001300
Closed	00913100002000
Closed	00913100001900
Closed	00913100001800
Closed	00913100001600
Closed	00913100002200
Closed	00403800004402
Closed	00913500000100
Closed	00913500000200
Closed	00913500000900
Closed	00913500001000
Closed	00913500001100
Closed	00913500001200
Closed	00913500001300
Closed	00913500001400
Closed	00913500001500
Closed	00913500001600
Closed	00913500001700
Closed	00913500001800
Closed	00913500001900
Closed	00913500004500
Closed	00913500004600
Closed	00913500004700
Closed	00913500004800
Closed	00913500004900
Closed	00913500000300
Closed	00913500000800
Closed	00913500000700
Closed	00913500000500
Closed	00913500000600
Closed	00913500000400
Closed	00913100001100
Closed	00913100001200
Closed	00913100000800
Closed	00913100000700
Closed	00912700001200
Closed	27063000300500
Closed	00913100000100

Accessory Dwelling Units

Index # - File Name: 1.0022 - Single Family Dwellings Data\_Snohomish County.pdf

Closed	00913100000200
Closed	00913100000300
Closed	00913100000400
Closed	00912700000700
Closed	00912700000800
Closed	00912700000500
Closed	00912700001100
Closed	32090700102800
Closed	00912600004700
Closed	00912300000100
Closed	00912300000200
Closed	00912300000300
Closed	00912300000400
Closed	00912600004200
Closed	00912600002000
Closed	00912600001800
Closed	00912600001700
Closed	00912600001400
Closed	00912600001300
Closed	00912600001200
Closed	00912600001100
Closed	00912600002200
Closed	00912600002300
Closed	00912600002400
Closed	00912600000700
Closed	00912600000800
Closed	00912400000300
Closed	00912200001600
Closed	00912200001500
Closed	00912200003300
Closed	00912200002700
Closed	00912200002400
Closed	00912200002600
Closed	00912200002200
Closed	00912200002800
Closed	00912200002300
Closed	00912200002500
Closed	00912200000100
Closed	27052700207600
Closed	27052700207800
Closed	27052700207900
Closed	32071200101800
Closed	00912200001800
Closed	00912200003200
Closed	00912200001400
Closed	00912200000200
Closed	00912200000300

Accessory Dwelling Units

Index # - File Name: 1.0022 - Single Family Dwellings Data\_Snohomish County.pdf

Closed	0091220000400
Closed	00912200003700
Closed	00912200003800
Closed	00912200003900
Closed	00912200004000
Closed	00912200002900
Closed	00912200001300
Closed	00911900000100
Closed	00911900000200
Closed	00911900000300
Closed	00911900000500
Closed	00911900000600
Closed	00911900000700
Closed	00911900000800
Closed	00911900000900
Closed	00911900001000
Closed	00911900001100
Closed	00911900001200
Closed	00911800000300
Closed	00911800000400
Closed	00494600301000
Closed	00429000000400
Closed	00911800000600
Closed	00911800000700
Closed	00911800000800
Closed	00911800000900
Closed	00911800001000
Closed	00911800001100
Closed	00911800001200
Closed	00911800001300
Closed	00911800001400
Closed	00911800001500
Closed	00911800001600
Closed	00911800001700
Closed	00911800001800
Closed	00911800001900
Closed	00911800002000
Closed	00911800002100
Closed	00911800002200
Closed	00911800002300
Closed	00911800002400
Closed	00916800000100
Closed	00916800000200
Closed	00916800000300
Closed	00916800000400
Closed	00916800000500
Closed	00916800000700

Accessory Dwelling Units

Index # - File Name: 1.0022 - Single Family Dwellings Data\_Snohomish County.pdf

Closed	0091680000800
Closed	0091680000900
Closed	0091680001000
Closed	0091680001100
Closed	0091680001200
Closed	0091680001300
Closed	0091680001400
Closed	0091680001500
Closed	0091680001600
Closed	0091680001700
Closed	0091680001800
Closed	0091680001900
Closed	0091680002000
Closed	0091680002100
Closed	0091680002200
Closed	0091680002300
Closed	0091680002500
Closed	0091680002600
Closed	0091680002700
Closed	0091680002800
Closed	0091680002900
Closed	0091680003000
Closed	0091680003100
Closed	0091680003200
Closed	0091680003300
Closed	0091680003400
Closed	0091680003500
Closed	0091680003600
Closed	0091680003700
Closed	0091680003800
Closed	0091680003900
Closed	0091680004000
Closed	0091680004100
Closed	0091680004200
Closed	0091680004300
Closed	0091680004400
Closed	0091680004500
Closed	0091680004600
Closed	0091680004700
Closed	0091680004800
Closed	0091680004900
Closed	0091680005000
Closed	0091680005100
Closed	0091680005200
Closed	0091680005300
Closed	0091680005400
Closed	0091680005500

Accessory Dwelling Units

Index # - File Name: 1.0022 - Single Family Dwellings Data\_Snohomish County.pdf

Closed	00916800005600
Closed	00916800005700
Closed	00916800005800
Closed	00916800005900
Closed	00916800006000
Closed	00916800006100
Closed	00916800006200
Closed	00916800006300
Closed	00916800006400
Closed	00916800006500
Closed	00916800006600
Closed	00916900002300
Closed	00916800006800
Closed	00916800006900
Closed	00916800007000
Closed	00916800007100
Closed	00916800007300
Closed	00916800007400
Closed	00916800007500
Closed	00916800007600
Closed	00916800008200
Closed	00916800008300
Closed	00916800008400
Closed	00916800008500
Closed	00916800008600
Closed	00916800008700
Closed	00916800008800
Closed	00916800007900
Closed	00916800008000
Closed	00916800009000
Closed	00916800009100
Closed	00916800009200
Closed	00916800009300
Closed	00916800009400
Closed	00916800009500
Closed	29051100107100
Closed	27061600301100
Closed	00466200003800
Closed	00917300000200
Closed	00917300000300
Closed	00917300000400
Closed	00917300000500
Closed	00917300000600
Closed	00917300000700
Closed	00917300000800
Closed	00917300001000
Closed	00917300001100

Accessory Dwelling Units

Index # - File Name: 1.0022 - Single Family Dwellings Data\_Snohomish County.pdf

Closed	00917300001600
Closed	28073000203500
Closed	00917300002000
Closed	00917200000200
Closed	00917200000300
Closed	00917200000500
Closed	00917200000600
Closed	00917200000700
Closed	00917200000800
Closed	00917200000900
Closed	00917200001000
Closed	00917200001100
Closed	00917200001300
Closed	00917200001400
Closed	00917200001500
Closed	00917200001600
Closed	00917200001700
Closed	00917200001800
Closed	00917200001900
Closed	00917200002000
Closed	00917200002700
Closed	00917200002100
Closed	00917200002200
Closed	00917200002300
Closed	00917200002400
Closed	00917200002500
Closed	00917200002600
Closed	00917200002800
Closed	00917200002900
Closed	00917200003100
Closed	00917200003200
Closed	00917200003300
Closed	00917200003400
Closed	00917200003500
Closed	00917200003600
Closed	00917200003700
Closed	00917200003900
Closed	00917200004000
Closed	00917200004100
Closed	00917200004300
Closed	00917200004400
Closed	00917200004500
Closed	00917200004600
Closed	00917200004700
Closed	00917200004800
Closed	00917200004900
Closed	00917200005000

Accessory Dwelling Units

Index # - File Name: 1.0022 - Single Family Dwellings Data\_Snohomish County.pdf

Closed	00917200005100
Closed	00917200005200
Closed	00917200005300
Closed	00917200005500
Closed	00917200005600
Closed	00917400000100
Closed	00917400000200
Closed	00917400000300
Closed	00917400000400
Closed	00917400000500
Closed	00917400000600
Closed	00917400000700
Closed	00917400000800
Closed	00917400000900
Closed	00917400001000
Closed	00917400001100
Closed	00917400001200
Closed	00917400001300
Closed	00917400001400
Closed	00917400001500
Closed	28042400409800
Closed	28042400409900
Closed	28042400410000
Closed	32063400402300
Closed	27050400301800
Closed	00917700000100
Closed	00917700000200
Closed	00917700002200
Closed	00917700002400
Closed	00917700002300
Closed	00917700000700
Closed	00917700000800
Closed	00917700000900
Closed	00917700001000
Closed	00917700001100
Closed	00917700001200
Closed	00917700001300
Closed	00917700001400
Closed	00917700001500
Closed	00917700001600
Closed	00917700001700
Closed	00917700001800
Closed	00917700001900
Closed	00917700002000
Closed	00917700000400
Closed	00917700000500
Closed	00917700000600

Accessory Dwelling Units

Index # - File Name: 1.0022 - Single Family Dwellings Data\_Snohomish County.pdf

Closed	00917600003100
Closed	00917600003200
Closed	00917600002200
Closed	00917600002800
Closed	30052500401600
Closed	00918800000200
Closed	00918800000300
Closed	00918800000400
Closed	00918800000500
Closed	00918800000600
Closed	00918800000700
Closed	00918800001000
Closed	00918800001100
Closed	00918800001200
Closed	00918800001300
Closed	00918800001400
Closed	00918800001500
Closed	00917600003600
Closed	00917600003900
Closed	00480401503605
Closed	00480401503604
Closed	00918000000100
Closed	00918000000200
Closed	00918000000300
Closed	00918000000400
Closed	00918000000500
Closed	00918000000600
Closed	00918000000700
Closed	00918000009400
Closed	00918000009500
Closed	00918000009600
Closed	00918000010100
Closed	00918000010200
Closed	00918000010300
Closed	00918000009800
Closed	00918000009900
Closed	00918000010000
Closed	00918000001300
Closed	00918000001400
Closed	00918000001500
Closed	00918000001600
Closed	00918000001700
Closed	00918000001800
Closed	00918000001900
Closed	00918000006100
Closed	00918000009200
Closed	00918000008300



Accessory Dwelling Units

Index # - File Name: 1.0022 - Single Family Dwellings Data\_Snohomish County.pdf

Closed	00918000008200
Closed	00918000001200
Closed	00918000002000
Closed	00918000006500
Closed	00918000006700
Closed	00918000006800
Closed	00918000006900
Closed	00918000007000
Closed	00918000007100
Closed	00918000007200
Closed	00918000007300
Closed	00918000007400
Closed	00918000007500
Closed	00918000007600
Closed	00918000007700
Closed	00918000007800
Closed	00918000008000
Closed	00918000008100
Closed	00918000008400
Closed	00918300000100
Closed	00918300000300
Closed	00918300000400
Closed	00918300000500
Closed	00918300000600
Closed	00918300000700
Closed	00918300000800
Closed	00918300000900
Closed	00918300001100
Closed	00918300001200
Closed	00918300001300
Closed	00918300001400
Closed	00918300001500
Closed	00918300001600
Closed	00918300001700
Closed	00918300003000
Closed	00918300003100
Closed	00918300003200
Closed	00918300001800
Closed	00918300001900
Closed	00918300002000
Closed	00918300002100
Closed	00918300002300
Closed	00918300002400
Closed	00918300002600
Closed	00918300002700
Closed	00918300002900
Closed	00918000008900

Accessory Dwelling Units

Index # - File Name: 1.0022 - Single Family Dwellings Data\_Snohomish County.pdf

Closed	00918000008500
Closed	00918000008700
Closed	00918000008800
Closed	00918000009000
Closed	00918000009100
Closed	00918000009300
Closed	00918000009700
Closed	00590700005403
Closed	00590700005402
Closed	00440300000100
Closed	00960005300300
Closed	31061700300500
Closed	00922700000300
Closed	00922700000400
Closed	00922700001500
Closed	00922700001600
Closed	00922700001700
Closed	00922700001900
Closed	00922700002100
Closed	00922700002200
Closed	00922700002400
Closed	00922700002500
Closed	00922700004200
Closed	00922700006400
Closed	00922700006500
Closed	00922700006600
Closed	00922700006700
Closed	00922700006800
Closed	00922700006900
Closed	00922700007000
Closed	00614700403400
Closed	00922700004300
Closed	00922700004400
Closed	00922700004500
Closed	00922700005300
Closed	00922700005400
Closed	00922700005500
Closed	00922700005600
Closed	00922700005700
Closed	00922700005800
Closed	00922700005900
Closed	00922700006000
Closed	00922700006100
Closed	00922700006200
Closed	00922700006300
Closed	00919800000100
Closed	00919800000200

Accessory Dwelling Units

Index # - File Name: 1.0022 - Single Family Dwellings Data\_Snohomish County.pdf

Closed	00919800002700
Closed	00919800000400
Closed	00919800000500
Closed	00919800000600
Closed	00919800000700
Closed	00919800001900
Closed	00919800002000
Closed	00919800002100
Closed	00919800002200
Closed	00919800002300
Closed	00919800002400
Closed	00919800002500
Closed	00919800002600
Closed	00919800000800
Closed	00919800000900
Closed	00919800001000
Closed	00919800001100
Closed	00919800001200
Closed	00919800001300
Closed	00919800001400
Closed	00919800001500
Closed	00919800001600
Closed	00919800001700
Closed	00919800001800
Closed	28082800101500
Closed	00919300000100
Closed	00919300000200
Closed	00919300000300
Closed	00919300000400
Closed	00919300000500
Closed	00919300000600
Closed	00919300000700
Closed	00919300004600
Closed	00919300004700
Closed	00919300004800
Closed	00919300005000
Closed	00919300005100
Closed	00919300005200
Closed	00919300005300
Closed	00919300004900
Closed	00919300000800
Closed	00919300000900
Closed	00919300001000
Closed	00919300001100
Closed	00919300001200
Closed	00919300001300
Closed	00919300001400

Accessory Dwelling Units

Index # - File Name: 1.0022 - Single Family Dwellings Data\_Snohomish County.pdf

Closed	00919300001500
Closed	00919300001600
Closed	00919300001700
Closed	00919300001800
Closed	00919300002000
Closed	00919300002100
Closed	00919300002200
Closed	00919300002300
Closed	00919300002400
Closed	00919300002600
Closed	00919300002700
Closed	00919300002800
Closed	00919300002900
Closed	00919300003100
Closed	00919300003200
Closed	00919300003300
Closed	00919300003400
Closed	00919300004300
Closed	00919300004400
Closed	00919300004500
Closed	00919300004200
Closed	00919300004100
Closed	00919300004000
Closed	00919300003900
Closed	00919300003800
Closed	00919300003700
Closed	00922700003300
Closed	00922700003400
Closed	00922700003500
Closed	00922700000600
Closed	00922700000800
Closed	00919300002500
Closed	00919100001500
Closed	00919100000600
Closed	00919100000700
Closed	00919100000800
Closed	00919100000900
Closed	00923200000100
Closed	00923200000200
Closed	00923200000300
Closed	00923200000400
Closed	00923200000500
Closed	00923200000600
Closed	00920700000100
Closed	00920700000300
Closed	00920700000400
Closed	00920700000600

Accessory Dwelling Units

Index # - File Name: 1.0022 - Single Family Dwellings Data\_Snohomish County.pdf

Closed	00920700000800
Closed	00919100000500
Closed	00919100001100
Closed	00919100001000
Closed	00919600000100
Closed	00919600000200
Closed	27050900103900
Closed	00920600000100
Closed	00920600000200
Closed	00920600000300
Closed	00920600000400
Closed	00920600000500
Closed	00920600000600
Closed	00920600000700
Closed	00920600000800
Closed	00920600000900
Closed	00920600001100
Closed	00920600001200
Closed	00920600001300
Closed	00920600001400
Closed	00920600001500
Closed	00920600001600
Closed	00920600001700
Closed	00920600001800
Closed	00920600002000
Closed	00920600002100
Closed	00920600002200
Closed	00920600002300
Closed	00921600001700
Closed	00414300001204
Closed	00919900000101
Closed	00919900000201
Closed	00919900000301
Closed	00919900000401
Closed	00919900000501
Closed	00919900000601
Closed	28073000203400
Closed	32061200301500
Closed	00897900000900
Closed	30051300100100
Closed	00897900000200
Closed	00897900002200
Closed	00897900002300
Closed	00897900002400
Closed	00897900002000
Closed	00897900005200
Closed	00897900003300

Accessory Dwelling Units

Index # - File Name: 1.0022 - Single Family Dwellings Data\_Snohomish County.pdf

Closed	00897900006400
Closed	00897900006900
Closed	00897900008400
Closed	28070600402100
Closed	28060200302900
Closed	00895200000200
Closed	29062300104600
Closed	00896400001300
Closed	00896400000300
Closed	00897900010300
Closed	00897900011500
Closed	00897900011200
Closed	00897900011300
Closed	00394400104000
Closed	00542900002500
Closed	00542900002400
Closed	32040500302200
Closed	00401000011700
Closed	00401100005600
Closed	00401100005700
Closed	00401100008100
Closed	28060900202400
Closed	00899600000400
Closed	00899600000500
Closed	00373700300301
Closed	30060500101500
Closed	30060500101600
Closed	00537800002301
Closed	00537800002302
Closed	00537800002303
Closed	00537800002304
Closed	32071600100900
Closed	00489100007300
Closed	00473300001602
Closed	00900500005000
Closed	00372900401402
Closed	00900500006300
Closed	00900700000500
Closed	00900500007500
Closed	00900500007300
Closed	00900700000200
Closed	27071100400800
Closed	00900800001600
Closed	00901200000100
Closed	00901200000400
Closed	00901300001900
Closed	27062400100600

Accessory Dwelling Units

Index # - File Name: 1.0022 - Single Family Dwellings Data\_Snohomish County.pdf

Closed	00902400000300
Closed	00902400000400
Closed	00902400000500
Closed	00902400000600
Closed	00902400000700
Closed	27062500400500
Closed	00373800600903
Closed	27051400202500
Closed	27051400202600
Closed	00372900600500
Closed	00372900600500
Closed	00372900600500
Closed	30061800401000
Closed	00902900000800
Closed	00902900000900
Closed	00902900001000
Closed	31050300200500
Closed	00556800101000
Closed	00513700007217
Closed	00911300000200
Closed	00440000201400
Closed	00597400001004
Closed	00911300001800
Closed	00911300002000
Closed	00911300000400
Closed	00911300001700
Closed	00911300001600
Closed	00911300001500
Closed	00911300001300
Closed	00911300001200
Closed	00911300001000
Closed	00911300002300
Closed	00911300002500
Closed	27073000300300
Closed	00911300000100
Closed	00911300002800
Closed	00911300002700
Closed	00910400002200
Closed	00910400001600
Closed	00910400004900
Closed	00910400004400
Closed	00910400004300
Closed	00910400003300
Closed	00910400003200
Closed	00910400005900
Closed	00910400003600
Closed	00910400003700

Accessory Dwelling Units

Index # - File Name: 1.0022 - Single Family Dwellings Data\_Snohomish County.pdf

Closed	00910400003800
Closed	00910400003900
Closed	00910400004000
Closed	00910400004100
Closed	00910400002000
Closed	00910400001700
Closed	00910400001800
Closed	00910400006000
Closed	00910400005000
Closed	00910400004800
Closed	00910400004700
Closed	00910400005100
Closed	00910400005200
Closed	00910400005300
Closed	00910400005400
Closed	00910400005500
Closed	00910400005600
Closed	00910400005700
Closed	00910400005800
Closed	00466900001400
Closed	31041800403800
Closed	00394405001101
Closed	00910400000300
Closed	00910400000400
Closed	00910400000500
Closed	00910400000600
Closed	00910400000700
Closed	00910400000800
Closed	00910400000900
Closed	00910400001000
Closed	00910400001200
Closed	00910400001300
Closed	00910400001400
Closed	00910400002100
Closed	00910400003100
Closed	00910400002800
Closed	00910400004600
Closed	00910400003000
Closed	00910400004200
Closed	00910400001900
Closed	00910400001500
Closed	00910400004500
Closed	00910400003400
Closed	00910400003500
Closed	00910400002900
Closed	28072500302800
Closed	00910000000200



Accessory Dwelling Units

Index # - File Name: 1.0022 - Single Family Dwellings Data\_Snohomish County.pdf

Closed	00910000003700
Closed	00910000003600
Closed	00910000003400
Closed	00910000002400
Closed	00910000002500
Closed	00910000002600
Closed	00910000002700
Closed	00910000003300
Closed	00910000003000
Closed	00910000002200
Closed	00910000002000
Closed	00910000002300
Closed	00910000003500
Closed	00910000003100
Closed	00910000002100
Closed	00910000001700
Closed	00910000001600
Closed	00910000001300
Closed	00910000003200
Closed	00910000001800
Closed	00910000001400
Closed	00910000001900
Closed	00910000002900
Closed	29051300101300
Closed	27051000408600
Closed	00909500001000
Closed	00909500000900
Closed	00909500000700
Closed	00909500000600
Closed	00909500000500
Closed	00909500000400
Closed	00909500000300
Closed	00909500000200
Closed	32052200304200
Closed	00909500001200
Closed	00909500002000
Closed	00909500001900
Closed	00909500001400
Closed	00909500002200
Closed	00909100003300
Closed	00909100008500
Closed	00372601101010
Closed	00909500000100
Closed	00909500002500
Closed	00909100008100
Closed	00909100007700
Closed	00909100007800

Accessory Dwelling Units

Index # - File Name: 1.0022 - Single Family Dwellings Data\_Snohomish County.pdf

Closed	00909100007900
Closed	00909100004700
Closed	00909100004600
Closed	00909100007400
Closed	00909100005400
Closed	00909100004400
Closed	00909100008000
Closed	00909100007100
Closed	00909100007200
Closed	00909100006900
Closed	00909100007000
Closed	00909100006100
Closed	00909100006300
Closed	00909100006400
Closed	00909100006500
Closed	00909100006600
Closed	00909100006700
Closed	00909100005600
Closed	00909100005700
Closed	00909100005800
Closed	00909100007600
Closed	00909100002900
Closed	00909100007500
Closed	00909100004300
Closed	00909100005500
Closed	00909100005900
Closed	00909100006200
Closed	00909100004100
Closed	00909100004200
Closed	00909100006000
Closed	00908800008000
Closed	00908800008100
Closed	00908800008200
Closed	00908800008300
Closed	00908800008400
Closed	00908800008500
Closed	00908800008600
Closed	00908800008700
Closed	00908800008800
Closed	00909100003200
Closed	00908800006800
Closed	00908800006900
Closed	00908800006400
Closed	29062300101100
Closed	00908800006200
Closed	00556600006700
Closed	00908500006400

Accessory Dwelling Units

Index # - File Name: 1.0022 - Single Family Dwellings Data\_Snohomish County.pdf

Closed	00908500006500
Closed	00908500006600
Closed	00908500006700
Closed	00908800005800
Closed	00908500005600
Closed	00908500005800
Closed	00908500005900
Closed	00908500006000
Closed	00908500006100
Closed	00908500006200
Closed	00908500005000
Closed	00908500005100
Closed	00908500005200
Closed	00908500005300
Closed	00908500004200
Closed	00908500003600
Closed	00908500003100
Closed	32053100402600
Closed	00908500000100
Closed	00908500002900
Closed	00908500002200
Closed	00908500002300
Closed	00908500002400
Closed	00908500002500
Closed	00908500000900
Closed	00908500001000
Closed	00908500001500
Closed	00908500001600
Closed	00908500001900
Closed	00908500002000
Closed	00908500000400
Closed	00908500000500
Closed	00908600000500
Closed	00908800000300
Closed	00908800000400
Closed	00908800000500
Closed	00908800000600
Closed	00908800000700
Closed	00908800000800
Closed	00908800000900
Closed	00908800001000
Closed	00908800001100
Closed	00908800001200
Closed	00908800001300
Closed	00908800001400
Closed	00908800001500
Closed	00908800001600

Accessory Dwelling Units

Index # - File Name: 1.0022 - Single Family Dwellings Data\_Snohomish County.pdf

Closed	00908800001700
Closed	00908800001800
Closed	00908800001900
Closed	00908800002000
Closed	00908800002100
Closed	00908800002200
Closed	00908800002300
Closed	00908800002400
Closed	00908800002500
Closed	00908800002600
Closed	00908800002700
Closed	00908800002800
Closed	00908800002900
Closed	00908800003000
Closed	00908800003100
Closed	00908800003200
Closed	00908800003300
Closed	00908800003400
Closed	00908800003500
Closed	00908800003600
Closed	00908800003800
Closed	00908800003900
Closed	00908800004000
Closed	00908800004100
Closed	00908800004200
Closed	00908800004300
Closed	00908800004400
Closed	00908800004500
Closed	00908800004700
Closed	00908800004900
Closed	00908800000100
Closed	00906000001400
Closed	00905800001000
Closed	00905800001100
Closed	30060200100200
Closed	00401000012400
Closed	00904000004800
Closed	00904000004900
Closed	00904000005200
Closed	00904000005300
Closed	00904000004300
Closed	00904000004400
Closed	00904000004500
Closed	00904000004600
Closed	00904100002300
Closed	00904000004000
Closed	00904000004100

Accessory Dwelling Units

Index # - File Name: 1.0022 - Single Family Dwellings Data\_Snohomish County.pdf

Closed	27091400200700
Closed	28043300300900
Closed	00904000001600
Closed	00904000001700
Closed	00904000001800
Closed	00904000001900
Closed	00904000002000
Closed	00904000002100
Closed	00904000002200
Closed	00904000002300
Closed	00904000002400
Closed	00904000002500
Closed	00904000002600
Closed	00904000002700
Closed	00904000002800
Closed	00904000002900
Closed	00904000003000
Closed	00904000003100
Closed	00904000003200
Closed	00904000003300
Closed	00904000003400
Closed	00904000001000
Closed	00904000001100
Closed	00904000001200
Closed	00903200001200
Closed	00903200000900
Closed	00903200000700
Closed	00903200000300
Closed	00902900002200
Closed	00902900002400
Closed	00496400001900
Closed	00908600000300
Closed	29062300400200
Closed	00908600000100
Closed	31061800102100
Closed	32043600102200
Closed	00403800000905
Closed	31061800100600
Closed	00907500000500
Closed	00907500000200
Closed	00907500000300
Closed	00513100004105
Closed	31062700300300
Closed	27063300302400
Closed	00467100002400
Closed	31061700301300
Closed	00907400001200

Accessory Dwelling Units

Index # - File Name: 1.0022 - Single Family Dwellings Data\_Snohomish County.pdf

Closed	00907400001300
Closed	00907400000900
Closed	00907400000300
Closed	00915300000400
Closed	00907600004200
Closed	00493600001101
Closed	29062300302900
Closed	00906900003900
Closed	00906900004000
Closed	00906900004100
Closed	00906900004200
Closed	00906900004300
Closed	00906900004400
Closed	00906900004500
Closed	00906900003100
Closed	00906900002000
Closed	00906900000100
Closed	00906900000200
Closed	00906900000300
Closed	00906900000400
Closed	00906900000500
Closed	00906900000600
Closed	00906900000700
Closed	00906900000800
Closed	00490100005500
Closed	32081200100700
Closed	00906000003300
Closed	28060300101700
Closed	30060700203700
Closed	30060700203800
Closed	30060700203900
Closed	00569000002601
Closed	28073500301000
Closed	00494511400900
Closed	30060500403600
Closed	00930600000700
Closed	00930600000800
Closed	00930600000900
Closed	00930600001000
Closed	00930600001100
Closed	00930600001200
Closed	00930600001300
Closed	00930600001400
Closed	00930600001500
Closed	00930600001600
Closed	00930600001700
Closed	00930600001800

Accessory Dwelling Units

Index # - File Name: 1.0022 - Single Family Dwellings Data\_Snohomish County.pdf

Closed	00930600001900
Closed	00930600002000
Closed	00930600002100
Closed	00930600002200
Closed	00930600002300
Closed	00930600002600
Closed	00930600002700
Closed	00930600002800
Closed	00930600002900
Closed	00930600003000
Closed	00930600003100
Closed	00930600003200
Closed	00930500002000
Closed	00930500002100
Closed	00930500002200
Closed	00930500002300
Closed	00930500002400
Closed	00930500002500
Closed	00930500002600
Closed	00930500002700
Closed	00930500002800
Closed	00930500002900
Closed	00930500003000
Closed	00930500003100
Closed	00930500003200
Closed	00930500003300
Closed	00930500003400
Closed	00930500003500
Closed	00930500003600
Closed	00930500003700
Closed	00930500003800
Closed	00930500003900
Closed	00930500004000
Closed	00930500004100
Closed	00930500004200
Closed	00930500004300
Closed	00931500000100
Closed	00931500000300
Closed	00931500000400
Closed	00931500000500
Closed	00931500000600
Closed	00931500000700
Closed	00931500000800
Closed	00931500000900
Closed	00931500001000
Closed	00931500001100
Closed	00931500001200

Accessory Dwelling Units

Index # - File Name: 1.0022 - Single Family Dwellings Data\_Snohomish County.pdf

Closed	00931500001300
Closed	00931500001400
Closed	00931500001500
Closed	00931500001600
Closed	00931500001700
Closed	00931500001800
Closed	00931500001900
Closed	00931500002000
Closed	00931500002100
Closed	00931500002200
Closed	00931500002300
Closed	00931500002400
Closed	00931500002500
Closed	00931500002600
Closed	00931500002700
Closed	00931500002800
Closed	00931500002900
Closed	00931500003000
Closed	00931500003100
Closed	00931500003200
Closed	00931500003300
Closed	00931500003400
Closed	00931500003500
Closed	00931500003600
Closed	00931500003700
Closed	00931500003800
Closed	00931500003900
Closed	00931500004000
Closed	00931500004100
Closed	00931500004200
Closed	00931500004400
Closed	00519000000701
Closed	00930600000100
Closed	00930600000200
Closed	00930600000300
Closed	00930600000400
Closed	00930600000500
Closed	00930600000600
Closed	00932200000400
Closed	00932200000500
Closed	00932200000600
Closed	00931400000700
Closed	00931400000800
Closed	00931100000100
Closed	00931100000200
Closed	00931100000300
Closed	00931100000400



Accessory Dwelling Units

Index # - File Name: 1.0022 - Single Family Dwellings Data\_Snohomish County.pdf

Closed	00931100000500
Closed	00931100000600
Closed	00931100000700
Closed	00931100000800
Closed	00931100001000
Closed	00931100001100
Closed	00931100001200
Closed	00931100001300
Closed	00931100001400
Closed	00931100001500
Closed	31052900202100
Closed	00932200001300
Closed	00932200001400
Closed	00933300000200
Closed	00933300004300
Closed	30052000302700
Closed	28072200201900
Closed	28072200202000
Closed	00568800201208
Closed	27053400206600
Closed	27053400206700
Closed	27053400206800
Closed	00932300000100
Closed	00932300000200
Closed	00932300000300
Closed	00932300000400
Closed	00932300000500
Closed	00932300000600
Closed	00932300000700
Closed	00932300000800
Closed	00932300000900
Closed	00932300001000
Closed	00932300001100
Closed	00932300001200
Closed	00932300001300
Closed	00932300001400
Closed	00932300001500
Closed	00932300001600
Closed	00932300001700
Closed	00932300001800
Closed	00932300001900
Closed	00932300002000
Closed	00932300002100
Closed	00932300002200
Closed	00932300002300
Closed	00932300002400
Closed	00932300002500

Accessory Dwelling Units

Index # - File Name: 1.0022 - Single Family Dwellings Data\_Snohomish County.pdf

Closed	00932300002600
Closed	00932300002700
Closed	00932300002800
Closed	00932300002900
Closed	00932300003000
Closed	00932300003100
Closed	00932300003200
Closed	00932300003300
Closed	00932300003400
Closed	00932300003500
Closed	00932300003600
Closed	00932300003700
Closed	00932300003800
Closed	00932300003900
Closed	00932300004000
Closed	00932300004100
Closed	00932300004200
Closed	00932300004300
Closed	00932300004400
Closed	31040800100600
Closed	29061600401300
Closed	00934400003900
Closed	00934400004000
Closed	00934400004100
Closed	00934400004200
Closed	00934400004300
Closed	00934400004400
Closed	00934400004500
Closed	00934400004600
Closed	00934400004700
Closed	00934400004800
Closed	00932900000600
Closed	00932900000700
Closed	00932900000800
Closed	00932900000900
Closed	00932900001000
Closed	00932900001100
Closed	00932900001200
Closed	00932900001300
Closed	00932900001400
Closed	00932900001500
Closed	00932900001600
Closed	00932900001700
Closed	00932900002600
Closed	00932900002700
Closed	00932900002800
Closed	00932900002900

Accessory Dwelling Units

Index # - File Name: 1.0022 - Single Family Dwellings Data\_Snohomish County.pdf

Closed	00932900003000
Closed	00932900003100
Closed	00932900003200
Closed	00932900003300
Closed	00932900003400
Closed	00932900003500
Closed	00932900003600
Closed	00932900003700
Closed	00932900003900
Closed	00932900004000
Closed	00932900003800
Closed	00932900004100
Closed	00932900004200
Closed	00932900004300
Closed	00932900004400
Closed	00932900004500
Closed	00932900004600
Closed	00932900004700
Closed	00932900004800
Closed	00932900005000
Closed	00932900005100
Closed	00932900005200
Closed	00932900005300
Closed	00932900005400
Closed	00932900005500
Closed	00932900001800
Closed	00932900001900
Closed	00932900002000
Closed	00932900002100
Closed	00932900002200
Closed	00932900002300
Closed	00932900002400
Closed	00932900002500
Closed	00933000000100
Closed	00933000000200
Closed	00933000000300
Closed	00933000000400
Closed	00933000000500
Closed	00933000000600
Closed	00933000000700
Closed	00933000000800
Closed	00933000000900
Closed	00933000001000
Closed	00933000001100
Closed	00933000001200
Closed	00933000001300
Closed	00934400009400

Accessory Dwelling Units

Index # - File Name: 1.0022 - Single Family Dwellings Data\_Snohomish County.pdf

Closed	00934400009500
Closed	00934400009600
Closed	00934400009700
Closed	00934400009800
Closed	00934400009900
Closed	00934400010000
Closed	00934400010100
Closed	00934400010200
Closed	00934400010300
Closed	00934400010400
Closed	00934400010500
Closed	00934400010600
Closed	00934400010700
Closed	00934400010800
Closed	00934400010900
Closed	00934400011000
Closed	00934400011100
Closed	00934400011200
Closed	00934400011300
Closed	00934400011400
Closed	00934400011500
Closed	00934400011600
Closed	00934400011700
Closed	00934400011800
Closed	00934400011900
Closed	00934400012000
Closed	00934400012100
Closed	00934400008200
Closed	00934400008300
Closed	00934400008400
Closed	00934400008500
Closed	00934400008600
Closed	00934400008700
Closed	00373002901104
Closed	00373002901105
Closed	00933000001500
Closed	00933000001600
Closed	00933000001700
Closed	00933000003400
Closed	00933000003500
Closed	00933000003600
Closed	00933000002500
Closed	00933000002400
Closed	00933000002300
Closed	00933000002200
Closed	00933000002100
Closed	00933000002000

Accessory Dwelling Units

Index # - File Name: 1.0022 - Single Family Dwellings Data\_Snohomish County.pdf

Closed	00933000001900
Closed	00933000001800
Closed	00933000003800
Closed	00933000003900
Closed	00933000004000
Closed	00933000004100
Closed	00933000002600
Closed	00933000002700
Closed	00933000002800
Closed	00933000002900
Closed	00933000003100
Closed	00933000003200
Closed	00932400000100
Closed	00932400000200
Closed	00934600000100
Closed	00934600000200
Closed	00934600000600
Closed	00934600000700
Closed	00934600000800
Closed	00934600000900
Closed	00934600001000
Closed	00934600001100
Closed	00934600001200
Closed	00934600001300
Closed	00934600001400
Closed	00932600000200
Closed	00932600000300
Closed	00932600000400
Closed	00932600000500
Closed	00932600000600
Closed	00932600000800
Closed	00932600000900
Closed	00932600001000
Closed	00932600001100
Closed	00932600001300
Closed	00932600000700
Closed	00933800000100
Closed	00933800000200
Closed	00933800000300
Closed	00933800000400
Closed	00933800000500
Closed	00933800000600
Closed	00933800000700
Closed	00933800000800
Closed	30081500202600
Closed	00403900019304
Closed	00476200201305

Accessory Dwelling Units

Index # - File Name: 1.0022 - Single Family Dwellings Data\_Snohomish County.pdf

Closed	0093360000100
Closed	0093360000200
Closed	0093360000300
Closed	0093360000400
Closed	0093360000500
Closed	0093360000600
Closed	00476200100307
Closed	00476200100308
Closed	00476200100309
Closed	00476200100310
Closed	00373002300403
Closed	00942500100100
Closed	00942500200100
Closed	00942500300100
Closed	00942500400100
Closed	00942500500100
Closed	00942500600100
Closed	00942500700100
Closed	00942500800100
Closed	00942500900100
Closed	00942501000100
Closed	00942501100100
Closed	00942501300100
Closed	00942501400100
Closed	00942501500100
Closed	00942501600100
Closed	00942501700100
Closed	00942501800100
Closed	00942501900100
Closed	00942502000100
Closed	00942502100100
Closed	00942501200100
Closed	00373001501205
Closed	27072900300200
Closed	00394507000200
Closed	00590700012500
Closed	00590700011600
Closed	00934900000100
Closed	00934900000200
Closed	00934900000300
Closed	00934900000400
Closed	00934900000500
Closed	00934900000600
Closed	00934900002100
Closed	00934900002200
Closed	00934900002300
Closed	00934900002400

Accessory Dwelling Units

Index # - File Name: 1.0022 - Single Family Dwellings Data\_Snohomish County.pdf

Closed	00934900002500
Closed	00934900002600
Closed	00934900002700
Closed	00476200100104
Closed	00934800000200
Closed	00934800000300
Closed	00934800000400
Closed	00934800000500
Closed	00934800000600
Closed	00934900001700
Closed	00934000000100
Closed	00934000000200
Closed	00934000000300
Closed	00934000000400
Closed	00934000000500
Closed	00934000000600
Closed	00934000000700
Closed	00934000000800
Closed	00934000000900
Closed	00934000001000
Closed	00934000001100
Closed	00934000001200
Closed	00934000001300
Closed	00934000001400
Closed	00934000001500
Closed	00934000001600
Closed	00934000001700
Closed	00934000001800
Closed	00934000001900
Closed	00934000002000
Closed	00934000002100
Closed	00934000002200
Closed	00934000002300
Closed	00934000002400
Closed	00934000002500
Closed	00934000002600
Closed	00934000002700
Closed	00934000002800
Closed	00934000002900
Closed	00934000003000
Closed	00934000003100
Closed	00934000003200
Closed	00934000003400
Closed	00934000003500
Closed	00934000003600
Closed	00934000003700
Closed	00934000003800

Accessory Dwelling Units

Index # - File Name: 1.0022 - Single Family Dwellings Data\_Snohomish County.pdf

Closed	0093400003300
Closed	0093400003900
Closed	0093400004000
Closed	00934000013300
Closed	00934000008300
Closed	00934000004100
Closed	00934000004200
Closed	00934000004300
Closed	00934000004400
Closed	00934000004500
Closed	00934000004600
Closed	00934000004700
Closed	00934000005600
Closed	00934000004800
Closed	00934000004900
Closed	00934000005000
Closed	00934000005100
Closed	00934000005200
Closed	00934000005300
Closed	00934000005400
Closed	00934000005500
Closed	00934000005700
Closed	00934000005800
Closed	00934000005900
Closed	00934000006000
Closed	00934000006100
Closed	00934000006200
Closed	00934000011700
Closed	00934000013400
Closed	00934000013500
Closed	00934000013600
Closed	00934000010500
Closed	00934000010600
Closed	00934000010700
Closed	00934000010800
Closed	00934000013100
Closed	00934000013200
Closed	00934000010900
Closed	00934000011000
Closed	00934000011100
Closed	00934000011200
Closed	00934000012500
Closed	00934000012600
Closed	00934000012700
Closed	00934000012800
Closed	00934000012900
Closed	00934000013000



Accessory Dwelling Units

Index # - File Name: 1.0022 - Single Family Dwellings Data\_Snohomish County.pdf

Closed	00934000011300
Closed	00934000011400
Closed	00934000011500
Closed	00934000011600
Closed	00934000012400
Closed	00934000012300
Closed	00934000012200
Closed	00934000011900
Closed	00934000012000
Closed	00934000012100
Closed	00934000011800
Closed	00934000009400
Closed	00935200000200
Closed	00935200000300
Closed	00935200000400
Closed	00935200000500
Closed	00935200000600
Closed	00935200000700
Closed	00935200000800
Closed	00935200000900
Closed	00935200001100
Closed	00935200001200
Closed	00935200001300
Closed	00935200001400
Closed	00935200001500
Closed	00935200001600
Closed	00935200001700
Closed	00935200001800
Closed	00937100000200
Closed	00934000009100
Closed	00934000009000
Closed	00934000008800
Closed	00934000008700
Closed	00934000008600
Closed	00934000008500
Closed	00937100000400
Closed	30063300301700
Closed	29063100201100
Closed	00389400300101
Closed	00935100000300
Closed	00935100000400
Closed	00935100000700
Closed	00935100000800
Closed	00935100000900
Closed	00935100001000
Closed	00935100001100
Closed	00935100001200

Accessory Dwelling Units

Index # - File Name: 1.0022 - Single Family Dwellings Data\_Snohomish County.pdf

Closed	00935100001300
Closed	00935100001500
Closed	00935100006600
Closed	00935100006000
Closed	00935100005900
Closed	00935100006300
Closed	00935100004700
Closed	00935100004500
Closed	00935100004300
Closed	00935100004100
Closed	00935100004000
Closed	00935100003900
Closed	00935100003800
Closed	00935100003700
Closed	00935100003600
Closed	00935100003500
Closed	00935100003400
Closed	00935100003300
Closed	00935100003200
Closed	00935100003100
Closed	00935100003000
Closed	00935100002900
Closed	00935100002800
Closed	00935100002700
Closed	00935100002600
Closed	00935100002500
Closed	00935100002400
Closed	00935100002300
Closed	00935100002200
Closed	00935100002100
Closed	00935100002000
Closed	00935100001900
Closed	00936100001600
Closed	00936100001800
Closed	00935900001600
Closed	00935900000200
Closed	00935900000300
Closed	00935900000400
Closed	00935900000500
Closed	00935900000600
Closed	00935900000700
Closed	00935900000800
Closed	00935900000900
Closed	00935900001000
Closed	00935900001100
Closed	00935900001200
Closed	00935900001300

Accessory Dwelling Units

Index # - File Name: 1.0022 - Single Family Dwellings Data\_Snohomish County.pdf

Closed	00935900001400
Closed	00935900001500
Closed	00935900001700
Closed	00935900001800
Closed	00935900001900
Closed	00935900002000
Closed	00935900002100
Closed	00935900002200
Closed	00935900002300
Closed	00935900002400
Closed	00935900000100
Closed	00780200001100
Closed	00938800000200
Closed	00938800000300
Closed	00938800000400
Closed	00938800000500
Closed	00394401701700
Closed	00394401706600
Closed	00935100001400
Closed	00935100001600
Closed	00935100001700
Closed	00935100001800
Closed	00936100000700
Closed	00936100000800
Closed	00936100000900
Closed	00936100001000
Closed	00936100001100
Closed	00936100001200
Closed	00936100001300
Closed	00936300000200
Closed	00936300000100
Closed	00936300000300
Closed	00936300000400
Closed	00936300000500
Closed	00936300000600
Closed	00936300000700
Closed	00936300000800
Closed	00936300000900
Closed	00936300001000
Closed	00936300001100
Closed	00936300001200
Closed	00936300001300
Closed	00936300001400
Closed	00936300001500
Closed	00936300001600
Closed	00936300001700
Closed	00936300001800

Accessory Dwelling Units

Index # - File Name: 1.0022 - Single Family Dwellings Data\_Snohomish County.pdf

Closed	00936300001900
Closed	00936300002000
Closed	00936300002100
Closed	00936300002200
Closed	00936300002300
Closed	00936300002400
Closed	00936300002500
Closed	00936300002600
Closed	00936300002800
Closed	00936300002900
Closed	00936300003000
Closed	00936300003100
Closed	00936900000100
Closed	00936900000200
Closed	00936900000300
Closed	00936900000400
Closed	00936900000500
Closed	00936900000600
Closed	00936900000700
Closed	00936900000800
Closed	00936900000900
Closed	00936900001000
Closed	00936900001100
Closed	00936900001200
Closed	00936900001300
Closed	00936900001400
Closed	00936900001500
Closed	00936900001600
Closed	00936900001700
Closed	00936900001800
Closed	00936900001900
Closed	00936900002000
Closed	00936900002100
Closed	00383600004500
Closed	00373002300300
Closed	00373002300200
Closed	27090900101000
Closed	00936100000100
Closed	00936100000200
Closed	00936100000300
Closed	00494511400800
Closed	00556600003400
Closed	27061900405400
Closed	00493301500202
Closed	32042400300800
Closed	29071900100600
Closed	29052600204100

Accessory Dwelling Units

Index # - File Name: 1.0022 - Single Family Dwellings Data\_Snohomish County.pdf

Closed	30040600201200
Closed	31051300203000
Closed	00471300006100
Closed	00607900001100
Closed	00554500015901
Closed	30062800201400
Closed	00513100004107
Closed	31060700300200
Closed	00490900000500
Closed	30052100112100
Closed	30052100112200
Closed	00950600000200
Closed	00950600000300
Closed	00950600002600
Closed	00950600002700
Closed	00950600002800
Closed	00950600002900
Closed	00950600003000
Closed	00950600003100
Closed	00950600003300
Closed	00950600003500
Closed	00950600003600
Closed	00950600003700
Closed	00950600003800
Closed	00950600003900
Closed	00950600004800
Closed	00950600004900
Closed	00950600005000
Closed	00950600005200
Closed	00938300000100
Closed	00938300000200
Closed	00938300000300
Closed	00938300000400
Closed	00938300000500
Closed	00938300000600
Closed	00938300000700
Closed	00938300000800
Closed	00938300000900
Closed	00938300001000
Closed	00938300001100
Closed	00938300001200
Closed	00938300001300
Closed	00938300001400
Closed	00938300001500
Closed	00938300001600
Closed	00938300001700
Closed	00938300001800

Accessory Dwelling Units

Index # - File Name: 1.0022 - Single Family Dwellings Data\_Snohomish County.pdf

Closed	00938300001900
Closed	00938300002000
Closed	00938300002100
Closed	00938300002200
Closed	00938300002300
Closed	00938300002400
Closed	00938300002500
Closed	00938300002600
Closed	00938300002700
Closed	00938300002800
Closed	00938300002900
Closed	00938300003000
Closed	00938300003100
Closed	00394402602100
Closed	00937500000500
Closed	00937500001400
Closed	00940000000100
Closed	00940000000200
Closed	00940000000300
Closed	00940000000400
Closed	00940000000500
Closed	00940000000900
Closed	00940000001000
Closed	00940000001100
Closed	00940000001200
Closed	00940000001300
Closed	00940000001400
Closed	00940000001500
Closed	00940000001600
Closed	00940000001900
Closed	00940000002000
Closed	00940000002100
Closed	32071700400500
Closed	30040200400100
Closed	30071200102100
Closed	32043600101500
Closed	00590700021606
Closed	00938900000200
Closed	00938900000300
Closed	00938900000400
Closed	00938900000500
Closed	00938900000600
Closed	00938900000700
Closed	00938900000800
Closed	00938900000900
Closed	00938900001000
Closed	00938900001100



Accessory Dwelling Units

Index # - File Name: 1.0022 - Single Family Dwellings Data\_Snohomish County.pdf

Closed	00373800600904
Closed	00373800600904
Closed	00373800600904
Closed	00373800600904
Closed	00373800600904
Closed	00373800600904
Closed	00373800600904
Closed	00373800600904
Closed	00373800600904
Closed	00939800002300
Closed	00939800002400
Closed	30041300400500
Closed	30041300400600
Closed	00379500000703
Closed	27072900100400
Closed	32052000400300
Closed	00373800600904
Closed	00373800600904
Closed	00373800600904
Closed	00373800600904
Closed	00373800600904
Closed	00373800600904
Closed	00373800600904
Closed	00373800600904
Closed	00373800600904
Closed	00373800600904
Closed	00373800600904
Closed	00373800600904
Closed	00373800600904
Closed	00373800600904
Closed	00373800600904
Closed	00373800600904
Closed	00373800600904
Closed	00373800600904
Closed	00373800600904
Closed	00373800600904
Closed	29072800302500
Closed	00939700000100
Closed	00939700000200
Closed	00939700000300
Closed	00939700000400
Closed	00939700000500
Closed	00939700000600
Closed	00626200000100
Closed	00939700000900
Closed	00939700001100
Closed	00939700001300
Closed	00939700001400
Closed	00939700001500
Closed	00939700001700
Closed	00939700001800
Closed	00939700001900
Closed	00939700002700
Closed	00939700002800



Accessory Dwelling Units

Index # - File Name: 1.0022 - Single Family Dwellings Data\_Snohomish County.pdf

Closed	00939300000100
Closed	00939300000300
Closed	00939300000400
Closed	00939300000500
Closed	00939300000600
Closed	00939300000700
Closed	00939300000800
Closed	00939300000900
Closed	00939300001000
Closed	00939300001100
Closed	00939300001200
Closed	00939600000200
Closed	00939600000300
Closed	00939600000400
Closed	00939600001000
Closed	00939600001100
Closed	00939600001200
Closed	00939600001300
Closed	00939600001400
Closed	00939600001500
Closed	00939600001600
Closed	00939600001700
Closed	00939600001800
Closed	00939600001900
Closed	00939600002000
Closed	00939600002100
Closed	00939600002200
Closed	00939700002100
Closed	00939700002200
Closed	00939700002300
Closed	00939700002500
Closed	00941300000100
Closed	00941300000200
Closed	00941300000300
Closed	00941300000400
Closed	00941300000500
Closed	00941300000800
Closed	00941300000900
Closed	00941300001000
Closed	00941300001100
Closed	00941300001200
Closed	00941300001300
Closed	00941300001400
Closed	00941300001500
Closed	00941300001600
Closed	00941300001700
Closed	00941300001800

Accessory Dwelling Units

Index # - File Name: 1.0022 - Single Family Dwellings Data\_Snohomish County.pdf

Closed	00941300001900
Closed	00941300002000
Closed	00940100000300
Closed	00940100000400
Closed	00940100000500
Closed	00940100000600
Closed	00940100000700
Closed	00940100000800
Closed	00940100000900
Closed	00940100001000
Closed	00940100001100
Closed	00940100001200
Closed	00940100001300
Closed	00940100001400
Closed	00940100001500
Closed	00940100001600
Closed	00940100001700
Closed	00940100001800
Closed	00940100001900
Closed	00940100002000
Closed	00940100002100
Closed	00940100002200
Closed	00940100002300
Closed	00941200002500
Closed	00941200002600
Closed	00941200002700
Closed	00941200002800
Closed	00941200002900
Closed	00941200003000
Closed	00941200003400
Closed	00941200003500
Closed	00941200003600
Closed	00941200003700
Closed	00941200003800
Closed	00941200003900
Closed	00941200004000
Closed	00941200004100
Closed	00941200004200
Closed	00941200004300
Closed	00941200004400
Closed	00941800000600
Closed	00941800000500
Closed	00941800000400
Closed	00941800000300
Closed	00941800000200
Closed	00941800000100
Closed	00940500000100

Accessory Dwelling Units

Index # - File Name: 1.0022 - Single Family Dwellings Data\_Snohomish County.pdf

Closed	00940500000200
Closed	00940500000300
Closed	00940500000400
Closed	00940500000500
Closed	00940500000600
Closed	00940500000700
Closed	00940500000800
Closed	00940500000900
Closed	00941200005200
Closed	00939200000100
Closed	00939200000200
Closed	00939200000300
Closed	00939200000400
Closed	00939200000500
Closed	00939200000600
Closed	00939200000700
Closed	00939200000800
Closed	00939200000900
Closed	00939200001000
Closed	00939200001100
Closed	00939200001200
Closed	00939200001300
Closed	00939200001400
Closed	00939600002400
Closed	00941200002200
Closed	00941200004600
Closed	00941200004700
Closed	00941200004800
Closed	00941200004900
Closed	00543300001900
Closed	00941700000300
Closed	00941700000400
Closed	00941700000900
Closed	00940900001500
Closed	00940900001600
Closed	00940900001700
Closed	00940900001800
Closed	00940900001000
Closed	00940900001100
Closed	00940900001200
Closed	00940900002600
Closed	00942000000100
Closed	00942000000200
Closed	00942000000300
Closed	00942000000500
Closed	00942000000700
Closed	00942000000800

Accessory Dwelling Units

Index # - File Name: 1.0022 - Single Family Dwellings Data\_Snohomish County.pdf

Closed	0094200000900
Closed	0094200001000
Closed	0094200001100
Closed	00940900002800
Closed	00940900002900
Closed	00940900003000
Closed	00940900003100
Closed	00940900003200
Closed	00940900003300
Closed	00940900003400
Closed	00940900003500
Closed	00942000002400
Closed	00942000002500
Closed	00942000002600
Closed	00942000002700
Closed	00942000002800
Closed	00942000002900
Closed	00940900004000
Closed	00942000003100
Closed	00942000003200
Closed	00942000004300
Closed	00942000003400
Closed	00942000003500
Closed	00942000006200
Closed	00942000005800
Closed	00942000005900
Closed	00473600003000
Closed	00941700001100
Closed	00942300000100
Closed	00942300000500
Closed	00942300000700
Closed	00942300000800
Closed	00942300002300
Closed	00942300002400
Closed	00942300002500
Closed	00941900000300
Closed	00941900000400
Closed	00941900000500
Closed	00941900000600
Closed	00941900000800
Closed	00941900001000
Closed	00941900001100
Closed	00941900001200
Closed	00941900001400
Closed	00941900001500
Closed	00941900001600
Closed	00941900001700

Accessory Dwelling Units

Index # - File Name: 1.0022 - Single Family Dwellings Data\_Snohomish County.pdf

Closed	00942300001000
Closed	00942300001100
Closed	00942300001200
Closed	00942300001400
Closed	00942300001500
Closed	00942300001800
Closed	00942300001900
Closed	00942300002000
Closed	00941900001900
Closed	00375000001201
Closed	00941900002300
Closed	00375000001202
Closed	28061100203700
Closed	00942900000100
Closed	00942900000200
Closed	00942900000300
Closed	00942900000400
Closed	00942900000600
Closed	00513800009516
Closed	00461000500818
Closed	00608100200401
Closed	00944300000200
Closed	00944300000300
Closed	00944300000400
Closed	00944300000500
Closed	00944300000600
Closed	00492000300200
Closed	30051600307400
Closed	30051600307500
Closed	30051600111800
Closed	30051600111800
Closed	30052500401000
Closed	30060700203600
Closed	28060300101900
Closed	30061400100600
Closed	00915300000800
Closed	31043500403400
Closed	00394403907600
Closed	00907400000100
Closed	00907400000200
Closed	00907500000600
Closed	00907500000700
Closed	29070500201100
Closed	32041700300300
Closed	00403800011202
Closed	32043600102200
Closed	29063600100300

Accessory Dwelling Units

Index # - File Name: 1.0022 - Single Family Dwellings Data\_Snohomish County.pdf

Closed	29061500404400
Closed	29061500404500
Closed	29061500404600
Closed	29061500404700
Closed	29070500201200
Closed	29070500201800
Closed	27063400202500
Closed	28060800100300
Closed	00908800000200
Closed	00908500005400
Closed	00908500005500
Closed	00908500004800
Closed	00908500004900
Closed	00908500006300
Closed	00908500005700
Closed	00394510201000
Closed	00909100003100
Closed	00909100011500
Closed	00909100003400
Closed	00909100007300
Closed	00556600006800
Closed	00909100008300
Closed	00909100003000
Closed	00909100008600
Closed	00909100008200
Closed	00909100008400
Closed	30050500301200
Closed	28062600102400
Closed	32100800201800
Closed	00910400002700
Closed	00910400002600
Closed	00910400001100
Closed	32090800401500
Closed	00910400002400
Closed	00911300002100
Closed	00911300000500
Closed	00911300000700
Closed	00911300001100
Closed	00513700007219
Closed	00513700007218
Closed	00372900600500
Closed	00372900600500
Closed	27062000203100
Closed	00372900600500
Closed	00372900600500
Closed	31052400201900
Closed	00375000006600

Accessory Dwelling Units

Index # - File Name: 1.0022 - Single Family Dwellings Data\_Snohomish County.pdf

Closed	28072800400200
Closed	32042100102300
Closed	32042100102400
Closed	27060600301000
Closed	00901200000200
Closed	00900700000100
Closed	32071700400700
Closed	30063300100300
Closed	28071800400500
Closed	32063500302100
Closed	00419500001503
Closed	31040900400600
Closed	31040900400100
Closed	31040900400200
Closed	28061400305600
Closed	00401000006400
Closed	27071800100600
Closed	30060500101300
Closed	30060500101400
Closed	00557600000500
Closed	00897900011100
Closed	27063300302500
Closed	00895900000800
Closed	00401000015900
Closed	00401000016000
Closed	00401000016100
Closed	27061900202000
Closed	00600900200703
Closed	00897900006500
Closed	00897900005100
Closed	00897900001100
Closed	00897900001500
Closed	27050900105700
Closed	00897900000100
Closed	30063500300900
Closed	00538000016602
Closed	00919900006601
Closed	30060600201500
Closed	00920600001000
Closed	00919100001200
Closed	00919100001300
Closed	00919100001400
Closed	30050500302600
Closed	30050500302700
Closed	30050500302800
Closed	30050500303000
Closed	30050500303100

Accessory Dwelling Units

Index # - File Name: 1.0022 - Single Family Dwellings Data\_Snohomish County.pdf

Closed	00919300003500
Closed	00922700000900
Closed	00922700001000
Closed	00922700001100
Closed	00922700001200
Closed	00922700001300
Closed	00922700003600
Closed	00922700003700
Closed	00922700003800
Closed	00922700003900
Closed	00922700004000
Closed	00922700004100
Closed	00919300001900
Closed	00922700004600
Closed	00922700004700
Closed	00922700004800
Closed	00922700004900
Closed	00922700005000
Closed	00922700005200
Closed	00922700002800
Closed	00922700002700
Closed	00922700002900
Closed	00922700003000
Closed	00922700003100
Closed	00922700003200
Closed	00922700000500
Closed	00922700000100
Closed	29051100300200
Closed	00918000005200
Closed	00918000005300
Closed	00918000003600
Closed	00918000003700
Closed	00918000003800
Closed	00918000003900
Closed	00918000004000
Closed	00918000004100
Closed	00918000004200
Closed	00918000004300
Closed	00918000004400
Closed	00918000004500
Closed	00918000004600
Closed	00918000004700
Closed	00918000004800
Closed	00918000004900
Closed	00918000005000
Closed	00918000006600
Closed	00922200000400



Accessory Dwelling Units

Index # - File Name: 1.0022 - Single Family Dwellings Data\_Snohomish County.pdf

Closed	00922200000400
Closed	00918000002100
Closed	00918000006300
Closed	00918000006400
Closed	00918000005600
Closed	00918000005700
Closed	00918000001100
Closed	00918000006200
Closed	00918000005100
Closed	00918000005400
Closed	00918000005500
Closed	00918000002200
Closed	00918000002300
Closed	00918000002400
Closed	00918000002500
Closed	00918000002600
Closed	00918000002700
Closed	00918000002800
Closed	00918000002900
Closed	00918000003000
Closed	00918000003100
Closed	00918000003200
Closed	00918000003300
Closed	00918000003400
Closed	00918000005800
Closed	00918000005900
Closed	00918000006000
Closed	00917600003800
Closed	00917600003000
Closed	00917600003400
Closed	00917600001000
Closed	00917600001100
Closed	00917600002300
Closed	00917600003300
Closed	00917600001300
Closed	00917600001400
Closed	00917600001500
Closed	00917600001600
Closed	00917600001700
Closed	00917600001800
Closed	00917700002100
Closed	00917300002300
Closed	00917600000400
Closed	00917600004400
Closed	00917600004700
Closed	00917600000700
Closed	00917600000100

Accessory Dwelling Units

Index # - File Name: 1.0022 - Single Family Dwellings Data\_Snohomish County.pdf

Closed	0091760000200
Closed	0091770000300
Closed	0091730000100
Closed	00917300001200
Closed	00917300001300
Closed	00917300001400
Closed	00917300001500
Closed	00917300000900
Closed	27053400402400
Closed	29051100106800
Closed	29051100107000
Closed	00916800008100
Closed	00916800008900
Closed	00916800007700
Closed	00916800007800
Closed	00916800006700
Closed	00494511301000
Closed	32090700102200
Closed	00911800000100
Closed	00911800000200
Closed	32072900301200
Closed	00912200003100
Closed	32053100102300
Closed	00912600001600
Closed	00912600001500
Closed	00912600004000
Closed	00912400000200
Closed	00912600002600
Closed	00912600000300
Closed	00912600003500
Closed	00912600003100
Closed	00912600003000
Closed	00912600002900
Closed	00912600002800
Closed	00912600002700
Closed	00912600003900
Closed	00912600002500
Closed	28060300301100
Closed	00912600004500
Closed	00913400000100
Closed	00913400000200
Closed	00466900004400
Closed	00913400000500
Closed	00913400002500
Closed	00913400001600
Closed	00913400001700
Closed	31041400301600

Accessory Dwelling Units

Index # - File Name: 1.0022 - Single Family Dwellings Data\_Snohomish County.pdf

Closed	0091400000100
Closed	0091400000200
Closed	0091400000300
Closed	0091400000400
Closed	0091400000500
Closed	0091400000600
Closed	0091400000700
Closed	0091400000800
Closed	0091400000900
Closed	0091400001000
Closed	0091400004200
Closed	0091400003800
Closed	0091400003600
Closed	0091400001600
Closed	0091400001700
Closed	0091400003200
Closed	0091400004800
Closed	0091400004700
Closed	0091400004600
Closed	0091400004000
Closed	0091400003900
Closed	0091400002700
Closed	0091400001300
Closed	00914100001000
Closed	00914100000600
Closed	00914100000700
Closed	00914100000800
Closed	00914000004300
Closed	00914000004500
Closed	00914700200500
Closed	00914700201200
Closed	00914700100500
Closed	00914700201400
Closed	00914000005300
Closed	00916500000900
Closed	27063300100900
Closed	28062400300400
Closed	27051600303600
Closed	00916900001000
Closed	00916900001100
Closed	00916900001200
Closed	00916900001300
Closed	00916900001400
Closed	00494511400100
Closed	00373002100807
Closed	00916400001400
Closed	00916400001500

Accessory Dwelling Units

Index # - File Name: 1.0022 - Single Family Dwellings Data\_Snohomish County.pdf

Closed	00443700003200
Closed	27061900405300
Closed	00930400000100
Closed	00930400000200
Closed	00930400000300
Closed	00930400000400
Closed	00930400000500
Closed	00930400000600
Closed	00930400000700
Closed	00930400000800
Closed	00930400000900
Closed	00930400001000
Closed	00930400001100
Closed	00930400001200
Closed	00930400001300
Closed	00930400001400
Closed	00930400001500
Closed	00930400001600
Closed	00930400001700
Closed	00930400001800
Closed	00930400001900
Closed	00930400002000
Closed	00930400002100
Closed	00930400002200
Closed	00930400002300
Closed	00930400002400
Closed	00930400002700
Closed	00930400002800
Closed	00930400002900
Closed	00930400003000
Closed	00930400003100
Closed	00930400003200
Closed	00930400003300
Closed	00930400003400
Closed	00930400003500
Closed	00930400003600
Closed	00930400003700
Closed	00930400003900
Closed	00930400004000
Closed	00930400004100
Closed	00930400004200
Closed	00930400004300
Closed	00930400004400
Closed	00930400004500
Closed	00930400004700
Closed	00930400004800
Closed	00930400004900

Accessory Dwelling Units

Index # - File Name: 1.0022 - Single Family Dwellings Data\_Snohomish County.pdf

Closed	00930400005000
Closed	00930400005100
Closed	00930400005200
Closed	00930400005300
Closed	00930400005400
Closed	00930400005500
Closed	00930400005600
Closed	00930400005700
Closed	00930400005800
Closed	00930400005900
Closed	00930400006000
Closed	00930400006100
Closed	00930400006200
Closed	00930400006300
Closed	00930400006400
Closed	00930400006500
Closed	00930400006600
Closed	00930400006700
Closed	00930400006800
Closed	00930400006900
Closed	00930400007000
Closed	00930400007100
Closed	00930400007200
Closed	00930400007300
Closed	00930400007400
Closed	00930400007500
Closed	00930400007600
Closed	00930400007700
Closed	00930400007800
Closed	00930400007900
Closed	00930400008000
Closed	00930400008100
Closed	00930400008200
Closed	00930400008300
Closed	00930400008400
Closed	00930400008500
Closed	00930400008600
Closed	00930400008700
Closed	00930400008800
Closed	00930400008900
Closed	00930400009000
Closed	00930400009100
Closed	00930400009200
Closed	00930400009300
Closed	00930400009400
Closed	00930400009500
Closed	00930400009600

Accessory Dwelling Units

Index # - File Name: 1.0022 - Single Family Dwellings Data\_Snohomish County.pdf

Closed	00930400009700
Closed	00930400009800
Closed	00930400009900
Closed	00930400010000
Closed	00930400010100
Closed	00930400010200
Closed	00930400010300
Closed	00930400010400
Closed	00930400010500
Closed	00930400010600
Closed	00930400010700
Closed	00930400010800
Closed	00930400010900
Closed	00930400011000
Closed	00930400011100
Closed	00930400011200
Closed	00930400011300
Closed	00930400011400
Closed	00930400011500
Closed	00930400011600
Closed	00930400011700
Closed	00930400011800
Closed	00930400011900
Closed	00930400012000
Closed	00930400012100
Closed	00930400002600
Closed	00930500000100
Closed	00930500000200
Closed	00930500000300
Closed	00930500000400
Closed	00930500000500
Closed	00930500000600
Closed	00930500000700
Closed	00930500000800
Closed	00930500001100
Closed	00930500001200
Closed	00930500001300
Closed	00930500001500
Closed	00930500001600
Closed	00930500001700
Closed	00929900000300
Closed	30073200100900
Closed	00929600003800
Closed	30040100101200
Closed	00929900000100
Closed	00929600003200
Closed	00929600003300

Accessory Dwelling Units

Index # - File Name: 1.0022 - Single Family Dwellings Data\_Snohomish County.pdf

Closed	00929600002000
Closed	30073200101100
Closed	00466700002000
Closed	00929900000500
Closed	00929900000600
Closed	00929900000700
Closed	00929900000800
Closed	00929900000900
Closed	00929900001000
Closed	00929900001100
Closed	00929900001200
Closed	00929900001300
Closed	00929900001400
Closed	00929900001500
Closed	00929900001600
Closed	00929900001700
Closed	00929900001800
Closed	00929900001900
Closed	00929900002000
Closed	00929900002100
Closed	00929900002200
Closed	00929900002300
Closed	00929900002400
Closed	00929900002500
Closed	00929900002600
Closed	00929900002700
Closed	00929900002800
Closed	00929900002900
Closed	00929900003000
Closed	00929600002500
Closed	00929600002600
Closed	00929600002700
Closed	00929600002800
Closed	00929600002900
Closed	00929600003000
Closed	00929600001800
Closed	00929600000900
Closed	00929600001000
Closed	00929600001200
Closed	00929600001300
Closed	00929600001400
Closed	00929600001500
Closed	00929600000400
Closed	00929600000100
Closed	00929600000200
Closed	00929100003100
Closed	00929100003200

Accessory Dwelling Units

Index # - File Name: 1.0022 - Single Family Dwellings Data\_Snohomish County.pdf

Closed	00929100003300
Closed	00929100003400
Closed	00929100003500
Closed	00929100009000
Closed	00929100005400
Closed	00929100005200
Closed	00929100008700
Closed	00929100008600
Closed	00929100007400
Closed	00929100007500
Closed	00929100007600
Closed	00929100007700
Closed	00929100007800
Closed	00929100007900
Closed	00929100008000
Closed	00929100008100
Closed	00929100008200
Closed	00929100008300
Closed	00929100008400
Closed	00929100008500
Closed	00929100005800
Closed	00929100005900
Closed	00929100006000
Closed	00929100006100
Closed	00929100006300
Closed	00929100006400
Closed	00929100006500
Closed	00929100006600
Closed	00929100006700
Closed	00929100006900
Closed	00929100007000
Closed	00929100007100
Closed	00929100006200
Closed	00929100006800
Closed	00929100002600
Closed	00929100002900
Closed	00929100003600
Closed	00929100001300
Closed	00929100001400
Closed	00929100001500
Closed	00929100001600
Closed	00929100001700
Closed	00929100001800
Closed	00929100001900
Closed	00929100002100
Closed	00929100002200
Closed	00929100002300



Accessory Dwelling Units

Index # - File Name: 1.0022 - Single Family Dwellings Data\_Snohomish County.pdf

Closed	00929100002400
Closed	00929100002500
Closed	00929100002700
Closed	00929100002800
Closed	00929100003700
Closed	00929100003800
Closed	00929100003900
Closed	00929100004000
Closed	00929100004100
Closed	00929100004200
Closed	00929100004300
Closed	00929100004400
Closed	00929100004500
Closed	00929100004600
Closed	00929100004700
Closed	00929100004800
Closed	00929100004900
Closed	00929100005000
Closed	00929100000900
Closed	00929100001000
Closed	00929100001100
Closed	00929100001200
Closed	30050100103300
Closed	30050100103400
Closed	28060200101500
Closed	27091500202700
Closed	00929100003000
Closed	00928500000400
Closed	30063500100500
Closed	00928500001600
Closed	32042100300600
Closed	30070100301200
Closed	00499100203403
Closed	30063500102400
Closed	28072700300800
Closed	28082800202900
Closed	00928600001000
Closed	00928200006200
Closed	00928200005900
Closed	00928200005700
Closed	00928200005600
Closed	00928200005500
Closed	00928200005400
Closed	00928200005300
Closed	00928200005200
Closed	00928200005100
Closed	00928200005000

Accessory Dwelling Units

Index # - File Name: 1.0022 - Single Family Dwellings Data\_Snohomish County.pdf

Closed	00928200004900
Closed	00928200004800
Closed	00928200004700
Closed	00928200004600
Closed	00928200004500
Closed	00928200004400
Closed	00928200004300
Closed	00928200004200
Closed	00928200004100
Closed	00928200004000
Closed	00928200010500
Closed	00928200010400
Closed	00928200010300
Closed	00928200010200
Closed	00928200010800
Closed	00928200010700
Closed	00928200007600
Closed	00928600002000
Closed	00928600002100
Closed	00928600002500
Closed	00928600002600
Closed	00928200007200
Closed	00928200007300
Closed	00928600002800
Closed	00928600002900
Closed	00928600003000
Closed	00928600002700
Closed	00928200003000
Closed	00928200002900
Closed	00928200002800
Closed	00928200002700
Closed	00928200002600
Closed	00928200001000
Closed	00928200000900
Closed	00928200000800
Closed	00928200000700
Closed	00928200000600
Closed	00928200000500
Closed	00928200000400
Closed	00928200000300
Closed	00928200000200
Closed	00928200000100
Closed	00928200011000
Closed	00928200003100
Closed	00928200003200
Closed	00928200003300
Closed	00928200003400

Accessory Dwelling Units

Index # - File Name: 1.0022 - Single Family Dwellings Data\_Snohomish County.pdf

Closed	00928200003500
Closed	00928200003600
Closed	00928200003700
Closed	00928200003800
Closed	00928200003900
Closed	00928200008900
Closed	00928200008800
Closed	00928200008700
Closed	00928200008600
Closed	00928200008500
Closed	00928200008400
Closed	00928200008300
Closed	00928200008200
Closed	00928200008100
Closed	00928200002000
Closed	00928200001900
Closed	00928200001800
Closed	00928200001700
Closed	00928200001600
Closed	00928200001500
Closed	00928200001300
Closed	00928200001200
Closed	00928200002500
Closed	00928200002400
Closed	00928200002300
Closed	00928200002200
Closed	00928200002100
Closed	00928200009500
Closed	00928200009400
Closed	00928200009300
Closed	00928200009200
Closed	00928200009100
Closed	00928200009000
Closed	00928200010100
Closed	00928200010000
Closed	00928200009900
Closed	00928200009800
Closed	00928200009700
Closed	00928600000900
Closed	00928600003700
Closed	00928600003900
Closed	00928600004000
Closed	00928600003300
Closed	00928600003100
Closed	00928600001100
Closed	00928600001200
Closed	00928600001300

Accessory Dwelling Units

Index # - File Name: 1.0022 - Single Family Dwellings Data\_Snohomish County.pdf

Closed	00928600001400
Closed	00928600001500
Closed	00928600001600
Closed	00928600001800
Closed	00928600001900
Closed	00928600003400
Closed	00928600004200
Closed	00928600004400
Closed	00928600004500
Closed	00928600004600
Closed	00928600004700
Closed	00928600004800
Closed	00928600004900
Closed	00928600005000
Closed	00928600005400
Closed	00928600005300
Closed	00928600005200
Closed	00928600005100
Closed	00928600005500
Closed	32080200402900
Closed	00927700000100
Closed	00928600002200
Closed	00927800001500
Closed	00927800001800
Closed	00556600011100
Closed	00490900000600
Closed	00927800001100
Closed	32063000402200
Closed	32063000402300
Closed	00927800000300
Closed	00927800000400
Closed	00927800000500
Closed	00927800000600
Closed	00927800000700
Closed	00927800002700
Closed	00927800002600
Closed	00927800000800
Closed	00927800000900
Closed	00927800001000
Closed	00927800001600
Closed	00927800002100
Closed	00927800002000
Closed	00927800002200
Closed	00927800002300
Closed	00927800002400
Closed	00927800002500
Closed	00927800002900

Accessory Dwelling Units

Index # - File Name: 1.0022 - Single Family Dwellings Data\_Snohomish County.pdf

Closed	00927800001200
Closed	00927800001300
Closed	00927800000100
Closed	30062100203100
Closed	29053600101000
Closed	00927700000300
Closed	00927700001300
Closed	00927700001400
Closed	00927700000500
Closed	00927700000600
Closed	00927700000700
Closed	00927700000800
Closed	00927700000900
Closed	00927700001000
Closed	00933900002900
Closed	00933900003000
Closed	00933900001300
Closed	00933900001400
Closed	00933900001700
Closed	00933900001800
Closed	00933900001900
Closed	00933900002000
Closed	00933900002100
Closed	00933900002200
Closed	00933900002300
Closed	00933900002400
Closed	00933900002500
Closed	00933900002600
Closed	00933900002700
Closed	00933900003400
Closed	00933900003500
Closed	00933900003600
Closed	00933900003700
Closed	00933900003800
Closed	00933900003900
Closed	00933900004000
Closed	00933900004100
Closed	00933900004200
Closed	00933900004300
Closed	00933900004400
Closed	00933900004500
Closed	00933900004600
Closed	00933900000900
Closed	00933900000100
Closed	00933900000200
Closed	00933900000300
Closed	00933900000400

Accessory Dwelling Units

Index # - File Name: 1.0022 - Single Family Dwellings Data\_Snohomish County.pdf

Closed	27062600201100
Closed	00471300006300
Closed	00394507000500
Closed	00471300006200
Closed	27090800103900
Closed	27090800104000
Closed	27090800104100
Closed	27090800103200
Closed	27090800103300
Closed	27090800103400
Closed	27090800103500
Closed	30072900401800
Closed	30072900402500
Closed	30072900401700
Closed	30072900401600
Closed	30072900202300
Closed	30072900202200
Closed	30072900202400
Closed	30072900201400
Closed	30072900201300
Closed	30072900201500
Closed	30072900201600
Closed	30072900201900
Closed	30072900201800
Closed	30072900202000
Closed	30073000101600
Closed	30073000101700
Closed	30073000101800
Closed	30073000101900
Closed	30073000102000
Closed	30073000102100
Closed	30072900202700
Closed	30072900202600
Closed	30072900202500
Closed	00926400002500
Closed	00926500000700
Closed	00926400003100
Closed	00926400003200
Closed	00926100000300
Closed	00926100000400
Closed	30061700201200
Closed	00926500000100
Closed	00926500000200
Closed	00926500000300
Closed	29050300101100
Closed	00556600008800
Closed	00926400003500

Accessory Dwelling Units

Index # - File Name: 1.0022 - Single Family Dwellings Data\_Snohomish County.pdf

Closed	00926400003600
Closed	00926400003700
Closed	00926400003800
Closed	00926400003900
Closed	00926400004000
Closed	00926400004100
Closed	00926400004200
Closed	00926400004300
Closed	00926400004400
Closed	00926400004500
Closed	00926400002800
Closed	00926400002900
Closed	00926100000700
Closed	00926100000800
Closed	00926100000900
Closed	00926400002200
Closed	00926400002300
Closed	00926400000700
Closed	00926400000800
Closed	00926400000900
Closed	00926400001000
Closed	00926400001100
Closed	00926400001200
Closed	00926400001300
Closed	00926400001400
Closed	28050100201900
Closed	00926100000100
Closed	00926300001300
Closed	00926300000500
Closed	00926300000600
Closed	00926300000700
Closed	00926300000800
Closed	00924000001000
Closed	00924000001100
Closed	00924000001200
Closed	00924000001300
Closed	00924000000300
Closed	00924000000400
Closed	00924000000500
Closed	00924000000600
Closed	00924500003700
Closed	00924500004300
Closed	00924500000100
Closed	00923900000500
Closed	00923900000600
Closed	00924100002000
Closed	28072100302700

Accessory Dwelling Units

Index # - File Name: 1.0022 - Single Family Dwellings Data\_Snohomish County.pdf

Closed	00924100002100
Closed	00924500007000
Closed	00924500007300
Closed	00924100000400
Closed	00924500000400
Closed	00924500002100
Closed	00924500002400
Closed	00924500006800
Closed	00924500007500
Closed	00924500007600
Closed	00924500007700
Closed	00924500007800
Closed	00924500007900
Closed	00924500008000
Closed	00924500008100
Closed	00924500008200
Closed	00924500008300
Closed	00924500008400
Closed	00924500008500
Closed	00924500008600
Closed	29060200402200
Closed	00924500004000
Closed	00924500004100
Closed	00924500004200
Closed	00924500004400
Closed	00924500004500
Closed	00924500004600
Closed	00924500004700
Closed	00924500004800
Closed	00924500004900
Closed	00924500005000
Closed	00924500005100
Closed	00924500005200
Closed	00924500005300
Closed	00924500005400
Closed	00924500005500
Closed	00924500005600
Closed	00924500005700
Closed	00924500005800
Closed	00924500005900
Closed	00924500006000
Closed	00924500006100
Closed	00924500006300
Closed	00924500006400
Closed	00924500006500
Closed	00924500006600
Closed	00924500001700



Accessory Dwelling Units

Index # - File Name: 1.0022 - Single Family Dwellings Data\_Snohomish County.pdf

Closed	00924500001800
Closed	00924500002600
Closed	00924500002700
Closed	00924500002800
Closed	00924500002900
Closed	00924500003000
Closed	00924500003100
Closed	00924500003200
Closed	00924500003300
Closed	00924500003400
Closed	00924500003500
Closed	00924500003600
Closed	00924500000900
Closed	00924500001000
Closed	00926600001300
Closed	00926600000100
Closed	00926600000200
Closed	31043100300300
Closed	00924300000800
Closed	00924300001000
Closed	00924300000300
Closed	00924300000400
Closed	00617300100200
Closed	00923500001200
Closed	00569000005404
Closed	00373002401104
Closed	00494511602800
Closed	29051100400600
Closed	28060800202700
Closed	00919900006801
Closed	00919900006701
Closed	00919900006501
Closed	00919900006401
Closed	00919900005001
Closed	00919900007301
Closed	00919900006301
Closed	00919900006201
Closed	00919900006101
Closed	00919900006001
Closed	00919900005901
Closed	00919900005701
Closed	00919900005601
Closed	00919900005501
Closed	00919900004201
Closed	00919900003601
Closed	00919100000300
Closed	00919100000400

Accessory Dwelling Units

Index # - File Name: 1.0022 - Single Family Dwellings Data\_Snohomish County.pdf

Closed	00919900003301
Closed	00919900006901
Closed	00919900007601
Closed	00919900007101
Closed	00543800003302
Closed	00891700000600
Closed	30063500100400
Closed	00890900005200
Closed	00890900005300
Closed	00890900004400
Closed	00890900004500
Closed	00890900004600
Closed	00890900004700
Closed	00890900004800
Closed	00890900004900
Closed	00890900005000
Closed	00890900004100
Closed	00890900004200
Closed	00890900003800
Closed	00890900003900
Closed	29052600201800
Closed	00894800000600
Closed	00894400000800
Closed	00893700000600
Closed	00591200100700
Closed	28051200200600
Closed	00891100013400
Closed	27070800300700
Closed	00890100002300
Closed	00590700018302
Closed	30051300301100
Closed	00890100001100
Closed	00890100000100
Closed	00885500002500
Closed	00885500002600
Closed	00885500002700
Closed	00885500002800
Closed	00885500002000
Closed	00885500002100
Closed	00885500000800
Closed	00885500001000
Closed	00885500000600
Closed	00885500003000
Closed	00885500003100
Closed	00885500003200
Closed	00885500003300
Closed	00885500004100

Accessory Dwelling Units

Index # - File Name: 1.0022 - Single Family Dwellings Data\_Snohomish County.pdf

Closed	00885500002300
Closed	00885500003700
Closed	32070900200700
Closed	00394507700601
Closed	27071800401500
Closed	00886900011700
Closed	00480401604003
Closed	28063100201200
Closed	32040900400100
Closed	29051100202400
Closed	32040600300700
Closed	27071800400100
Closed	32051800102300
Closed	30040100104200
Closed	32053300203000
Closed	00577700605500
Closed	30061600301300
Closed	00587400000400
Closed	00877700000100
Closed	29070700300400
Closed	29060400405500
Closed	27051400200100
Closed	00480700000605
Closed	31063300401500
Closed	27061800303700
Closed	00879600000200
Closed	00879300003200
Closed	00879300002200
Closed	00879300002600
Closed	00879300002700
Closed	00879300000200
Closed	27051000203700
Closed	29062300201500
Closed	31063300401100
Closed	30062500101400
Closed	00880400001300
Closed	32061700200200
Closed	00880400001800
Closed	29051400403400
Closed	00590700027002
Closed	00590700027003
Closed	28063200102900
Closed	28053600103700
Closed	31043100401200
Closed	00590700024305
Closed	31061800102300
Closed	00872000000300

Accessory Dwelling Units

Index # - File Name: 1.0022 - Single Family Dwellings Data\_Snohomish County.pdf

Closed	00401000015800
Closed	29062300101700
Closed	00529800001800
Closed	29062300105800
Closed	31043000300600
Closed	27072800200100
Closed	32062900300800
Closed	30062600300300
Closed	00868400000400
Closed	00868400000900
Closed	00394510200700
Closed	00403800010101
Closed	27091400300200
Closed	27061700303000
Closed	27090500400300
Closed	32060900400900
Closed	00504500600500
Closed	27061800101800
Closed	27071900402400
Closed	27071900402400
Closed	27052100404500
Closed	27052100401800
Closed	27091500201500
Closed	27091500201700
Closed	27061200402900
Closed	27051500104900
Closed	27051000101600
Closed	27061000401400
Closed	27051100102700
Closed	27051100300300
Closed	27051100404600
Closed	27071100302700
Closed	27050300302700
Closed	27070200200700
Closed	27070100401700
Closed	27070100401700
Closed	27080700201700
Closed	27090500103100
Closed	27090500100900
Closed	27090400101500
Closed	27060400101900
Closed	27070400400500
Closed	27063500302700
Closed	00372900900401
Closed	27073000402100
Closed	27063300301400
Closed	27063500205700

Accessory Dwelling Units

Index # - File Name: 1.0022 - Single Family Dwellings Data\_Snohomish County.pdf

Closed	27063500301300
Closed	27052800404100
Closed	27042300210300
Closed	00373700400601
Closed	00373700400701
Closed	00373701500205
Closed	00374100100401
Closed	00385200002900
Closed	00403900020002
Closed	00414400201900
Closed	00403800014707
Closed	00403800900300
Closed	00423200001000
Closed	00424100001300
Closed	00427100008500
Closed	00460100001300
Closed	00460000000300
Closed	00460100006700
Closed	00460100005000
Closed	00460200018100
Closed	00460200019600
Closed	00556600013100
Closed	00556600008600
Closed	00576800102300
Closed	00509000000702
Closed	00517000002200
Closed	00554500013800
Closed	00512200007900
Closed	28083500307100
Closed	28053600201200
Closed	00383600002900
Closed	28063200403300
Closed	28073200100300
Closed	28073400100100
Closed	28073400101000
Closed	28073400401500
Closed	28083400301300
Closed	28082900101500
Closed	28072900300900
Closed	28072900100500
Closed	28062500405700
Closed	28062200201900
Closed	28062200403100
Closed	28072000401100
Closed	28061600201600
Closed	28071800402100
Closed	28051700400800

Accessory Dwelling Units

Index # - File Name: 1.0022 - Single Family Dwellings Data\_Snohomish County.pdf

Closed	28061100101300
Closed	28051100402900
Closed	28061000401000
Closed	28070600100900
Closed	28050200101600
Closed	28050300101800
Closed	28060300101400
Closed	28060400101000
Closed	00761200000100
Closed	00658300000500
Closed	00761200000300
Closed	00396000003900
Closed	00396500005300
Closed	00473300501000
Closed	00480401500101
Closed	00469000001000
Closed	00422600000400
Closed	00493900004001
Closed	00480401602303
Closed	00570300202802
Closed	00570300102000
Closed	00574200005700
Closed	00574200004000
Closed	00574200000500
Closed	00574100005300
Closed	00608500200400
Closed	00599300000900
Closed	00597400000103
Closed	29051400103700
Closed	29051200400600
Closed	29060200300900
Closed	29060300200700
Closed	29063300101700
Closed	29063200100600
Closed	29062300401800
Closed	29062600201700
Closed	29062000303500
Closed	29061600303200
Closed	30062200202300
Closed	30052500300500
Closed	30072000203100
Closed	30052000302600
Closed	30052000201300
Closed	30041700400900
Closed	32041500400300
Closed	30070800300600
Closed	30051100401600

Accessory Dwelling Units

Index # - File Name: 1.0022 - Single Family Dwellings Data\_Snohomish County.pdf

Closed	30051000302200
Closed	30061000100400
Closed	30051100200800
Closed	30051200401100
Closed	30051200401800
Closed	30051300402200
Closed	30040300400500
Closed	30040300200700
Closed	30060300200600
Closed	00491900202500
Closed	00493300101402
Closed	00492100001600
Closed	00493700002500
Closed	00533400000300
Closed	00590700022101
Closed	00614100301000
Closed	00625200010300
Closed	00571900001400
Closed	00602500100603
Closed	00602500200605
Closed	00590700002700
Closed	00590700011500
Closed	00557000000300
Closed	00551500010900
Closed	00557300102100
Closed	00557300102300
Closed	00551500000700
Closed	00551500000100
Closed	00551500000200
Closed	00543300004300
Closed	00532000001400
Closed	00543800001801
Closed	00426900001200
Closed	00489100008800
Closed	00401000006800
Closed	00401000015700
Closed	00401000006500
Closed	00828500004000
Closed	30053100200800
Closed	31042200202100
Closed	31042200201400
Closed	31042000203200
Closed	31051600301900
Closed	31041500101300
Closed	31041400301000
Closed	31061800300500
Closed	31041800401900

Accessory Dwelling Units

Index # - File Name: 1.0022 - Single Family Dwellings Data\_Snohomish County.pdf

Closed	31060500202700
Closed	31040800302800
Closed	31041300300100
Closed	31040300302200
Closed	31040400101600
Closed	31040500301300
Closed	31052600101500
Closed	31062800100200
Closed	31062900102700
Closed	31053200201500
Closed	31053300400600
Closed	31063500300800
Closed	00379500000704
Closed	31063300301700
Closed	00482900004800
Closed	00394406200602
Closed	00394406200603
Closed	00394406200700
Closed	00394406200701
Closed	00394406200702
Closed	00394406200703
Closed	00394507100200
Closed	32052900302300
Closed	32052900103200
Closed	32062800401300
Closed	32063200201500
Closed	32073100100800
Closed	32052100302000
Closed	32042200101100
Closed	32042700400500
Closed	32051900201400
Closed	32051900401600
Closed	32052000401600
Closed	32041400302500
Closed	32051500400800
Closed	32061800100900
Closed	32051100401200
Closed	32041300200200
Closed	32040800100200
Closed	32040800202400
Closed	32040900301500
Closed	32040900401700
Closed	32050700201500
Closed	00727700000900
Closed	32080100301300
Closed	00630700001100
Closed	32040400400400



Accessory Dwelling Units

Index # - File Name: 1.0022 - Single Family Dwellings Data\_Snohomish County.pdf

Closed	00499100203400
Closed	00494600300303
Closed	00579100004303
Closed	00537400001800
Closed	00490900002900
Closed	00492400100200
Closed	00492400201100
Closed	30061700400600
Closed	30050600301100
Closed	27080600201700
Closed	32052900403800
Closed	00403900016305
Closed	30062400301100
Closed	30062500201100
Closed	30062500201900
Closed	30062400401700
Closed	32052200300500
Closed	29062000400600
Closed	29062000400600
Closed	28083000100700
Closed	27052800405500
Closed	00376800000600
Closed	00570300103202
Closed	30060800101900
Closed	30060800101600
Closed	00839100000400
Closed	00839100000800
Closed	31062700401300
Closed	31062200400400
Closed	28073000103300
Closed	27073200200400
Closed	30060200301900
Closed	00589600001800
Closed	00589600005000
Closed	00589600005100
Closed	00589600005700
Closed	00490200000400
Closed	00529100000300
Closed	00490500001400
Closed	32053300401800
Closed	32063400302300
Closed	32053600302400
Closed	32053500201200
Closed	32063100200500
Closed	32042700301000
Closed	00466900003700
Closed	00394507001600

Accessory Dwelling Units

Index # - File Name: 1.0022 - Single Family Dwellings Data\_Snohomish County.pdf

Closed	30042300302900
Closed	00597400001503
Closed	28073400304700
Closed	30060700200400
Closed	27062700201900
Closed	00494600201201
Closed	00597400002400
Closed	00824500000500
Closed	28072900404700
Closed	00587200004200
Closed	00403800002603
Closed	00466900001600
Closed	32040500300600
Closed	32060400400700
Closed	27053500102800
Closed	29052600102400
Closed	00394507100400
Closed	30060500101700
Closed	00394404406100
Closed	00394404406800
Closed	28083500306800
Closed	00394404303300
Closed	00394404501900
Closed	00394404502300
Closed	00394404506200
Closed	27051100104200
Closed	30060500102000
Closed	30060500402700
Closed	30060500402900
Closed	30060500403000
Closed	30060500402600
Closed	32090500401100
Closed	00551500010800
Closed	00858200000700
Closed	30060900301300
Closed	00862100000500
Closed	28050200305100
Closed	00862500000500
Closed	29061000201200
Closed	00543300001700
Closed	30060500402000
Closed	00850200001200
Closed	28062700101900
Closed	00394401807000
Closed	00849400000400
Closed	28081900200200
Closed	30063000403000

Accessory Dwelling Units

Index # - File Name: 1.0022 - Single Family Dwellings Data\_Snohomish County.pdf

Closed	28070600303500
Closed	00630600000800
Closed	28073000303400
Closed	27063300300900
Closed	27051600302800
Closed	28061400101100
Closed	28072300102100
Closed	00944000000100
Closed	31062700301800
Closed	00609100004300
Closed	00609100004700
Closed	29051100102600
Closed	31052600200700
Closed	27081100100400
Closed	00551400004600
Closed	30070100200700
Closed	30060800200900
Closed	30060800202000
Closed	32053300300400
Closed	30060500400800
Closed	00862100001300
Closed	31040700402200
Closed	31043100201300
Closed	31043100201000
Closed	27091600100400
Closed	31060900200800
Closed	32042700200300
Closed	28080900400200
Closed	28073500102200
Closed	28073500102700
Closed	28073500102600
Closed	28093100404100
Closed	00860500002400
Closed	32041600402000
Closed	31051300401000
Closed	30060500102200
Closed	00394404506600
Closed	00394404501000
Closed	00394404501300
Closed	00394404501600
Closed	31052500402000
Closed	29060500203700
Closed	31052400102000
Closed	31042300101300
Closed	32053300400600
Closed	30060800102600
Closed	28070300300500

Accessory Dwelling Units

Index # - File Name: 1.0022 - Single Family Dwellings Data\_Snohomish County.pdf

Closed	00532000002400
Closed	27053500102200
Closed	00585900002000
Closed	00492000303801
Closed	00824500000100
Closed	30061000200500
Closed	30050200401100
Closed	00808500000100
Closed	30062100202300
Closed	30060100200300
Closed	28062500301400
Closed	00629600004900
Closed	32063500200800
Closed	32063400302800
Closed	32043500100200
Closed	32063200202000
Closed	32063200303500
Closed	00589600009100
Closed	00589600001900
Closed	00589600002000
Closed	00384500009000
Closed	32071900100400
Closed	00836500004300
Closed	30060800103100
Closed	28073400101400
Closed	32071200101500
Closed	32080900202800
Closed	32053000101100
Closed	29061100100300
Closed	00844300000800
Closed	30063200202300
Closed	29050300403000
Closed	32051300400900
Closed	30050600301700
Closed	00394400401900
Closed	00394400402300
Closed	00394400406100
Closed	00494511601700
Closed	00494600200904
Closed	00494600201700
Closed	00494600202008
Closed	00494600202600
Closed	00489800001000
Closed	00489700100502
Closed	00489700202900
Closed	00499100104400
Closed	32060300301800

Accessory Dwelling Units

Index # - File Name: 1.0022 - Single Family Dwellings Data\_Snohomish County.pdf

Closed	32040300401200
Closed	00621500005100
Closed	00717400000300
Closed	32050700301700
Closed	32090800300600
Closed	32051300400100
Closed	32041100200900
Closed	32071000201200
Closed	32061000202100
Closed	32051900400400
Closed	32042600401500
Closed	32052300200800
Closed	32052300301100
Closed	32062100101800
Closed	32042200100700
Closed	32053200400400
Closed	32052900103900
Closed	00394507000900
Closed	00394507100600
Closed	00394509600400
Closed	00394406200801
Closed	00482900000100
Closed	00464600000100
Closed	00417900000500
Closed	31063100302000
Closed	31050500202600
Closed	31050500101300
Closed	31050400302600
Closed	31041200301100
Closed	31051300402600
Closed	31051300203300
Closed	31060900301000
Closed	31041000300700
Closed	31060700302100
Closed	31060700302200
Closed	31061800101100
Closed	31051800201300
Closed	31041400301400
Closed	31041400201100
Closed	31041400201200
Closed	31041500400800
Closed	31051700304700
Closed	30053100200500
Closed	30063200101500
Closed	00384500008700
Closed	00401000014300
Closed	00401000007900

Accessory Dwelling Units

Index # - File Name: 1.0022 - Single Family Dwellings Data\_Snohomish County.pdf

Closed	00401100014000
Closed	00489100010800
Closed	00489100013000
Closed	00495900001800
Closed	00480000012300
Closed	00489000009400
Closed	00520200008200
Closed	00551500003400
Closed	00557300102700
Closed	00557300102900
Closed	00590700005302
Closed	00590700005400
Closed	00604500000402
Closed	00600300301100
Closed	00560400004401
Closed	00557600002501
Closed	00557600002600
Closed	00790700000100
Closed	00611300016300
Closed	00797500000600
Closed	00541700001001
Closed	00590700031700
Closed	00590700025900
Closed	00492000107800
Closed	00471400005900
Closed	00467100002700
Closed	00442100002400
Closed	00385700900603
Closed	00440100002106
Closed	30050600200700
Closed	30051300401700
Closed	30041400401400
Closed	30041300300900
Closed	30051200101500
Closed	30060800101800
Closed	30060800100500
Closed	30051600100900
Closed	30051500201300
Closed	30062000202400
Closed	30072000400600
Closed	30062100203000
Closed	30062000300800
Closed	30042400102000
Closed	30042400102100
Closed	30042300202900
Closed	30062200401000
Closed	29061900101600

Accessory Dwelling Units

Index # - File Name: 1.0022 - Single Family Dwellings Data\_Snohomish County.pdf

Closed	29062000304400
Closed	29062400301600
Closed	29062100403900
Closed	29063200200400
Closed	29063200100200
Closed	29073100301700
Closed	29073000401000
Closed	29062600300700
Closed	29050300104100
Closed	29051200404400
Closed	29051200404800
Closed	29061400301000
Closed	00597400000104
Closed	00597400001502
Closed	00597400001701
Closed	00588100200404
Closed	00587400000100
Closed	00579200000900
Closed	00614700603800
Closed	00955100000100
Closed	00955100000400
Closed	00570300103101
Closed	00485000000800
Closed	00533700000500
Closed	00570400102400
Closed	00570500101000
Closed	00432100002000
Closed	00440400000100
Closed	00440400000200
Closed	00448600000300
Closed	00473300601100
Closed	00668900000400
Closed	00757800000100
Closed	00757800000200
Closed	28050300102000
Closed	28060300200900
Closed	28050900400100
Closed	28060900202200
Closed	28061200100900
Closed	28052000104300
Closed	28071900400700
Closed	28072000102000
Closed	28072000201800
Closed	28072000301400
Closed	28061600203100
Closed	28071600102700
Closed	28061500202000

Accessory Dwelling Units

Index # - File Name: 1.0022 - Single Family Dwellings Data\_Snohomish County.pdf

Closed	28062300102400
Closed	28062600202300
Closed	28062600202000
Closed	28072600101400
Closed	28072600300400
Closed	28073500102300
Closed	00373800700800
Closed	00379900000500
Closed	00375000001203
Closed	28083500407100
Closed	00512000203300
Closed	00506900000400
Closed	00509200101600
Closed	00464100001600
Closed	00556600009900
Closed	00617300201402
Closed	00583000000100
Closed	00609600000400
Closed	00629900000100
Closed	00631900003400
Closed	00624600002200
Closed	00624600000400
Closed	00623700004800
Closed	00460200021300
Closed	00460100007300
Closed	00460000002400
Closed	00452600100100
Closed	00419500001000
Closed	00433100002900
Closed	00433200001200
Closed	00403900025902
Closed	00375400000800
Closed	00373701001302
Closed	27052400200900
Closed	27052700402100
Closed	27062600303800
Closed	27052600404000
Closed	27052500401300
Closed	27052800103800
Closed	27063000204400
Closed	27063000101900
Closed	27062900403300
Closed	27053500402100
Closed	27063300301100
Closed	27053400203200
Closed	27053600302700
Closed	00373000100602



Accessory Dwelling Units

Index # - File Name: 1.0022 - Single Family Dwellings Data\_Snohomish County.pdf

Closed	00373002301603
Closed	27050400102300
Closed	27080100200600
Closed	27051000304000
Closed	27050900104800
Closed	27051600304900
Closed	27062100201300
Closed	27062100301500
Closed	27071900103300
Closed	27081800400400
Closed	32052000400100
Closed	27071800400400
Closed	00441900001800
Closed	00372800800106
Closed	00372800800102
Closed	00372800800103
Closed	00529800002100
Closed	00529800002300
Closed	30040300300900
Closed	30040300301200
Closed	00597400000205
Closed	31043100401500
Closed	32043600401900
Closed	29062300200800
Closed	29061600402600
Closed	30060200201500
Closed	00880400001000
Closed	00880400001200
Closed	00591200100309
Closed	00880400001400
Closed	00466200001700
Closed	00532000003500
Closed	30062500101500
Closed	28053600105300
Closed	29062300200900
Closed	00500100002802
Closed	00500100002803
Closed	00879000000600
Closed	00879300002800
Closed	27053300404400
Closed	29060300402200
Closed	28062400100400
Closed	30051100404900
Closed	00557600002702
Closed	27053300111700
Closed	32080100300200
Closed	30063600200900

Accessory Dwelling Units

Index # - File Name: 1.0022 - Single Family Dwellings Data\_Snohomish County.pdf

Closed	0048000006700
Closed	0048000006800
Closed	00493401001201
Closed	32063300304200
Closed	27050900401000
Closed	32053300203200
Closed	00467100010500
Closed	30061900303200
Closed	30061900302800
Closed	00885500003800
Closed	00885500003900
Closed	00885500003400
Closed	00885500003500
Closed	00885500005500
Closed	00885500005900
Closed	00885500000700
Closed	00885500000500
Closed	00885500001600
Closed	00885500000900
Closed	00885900000200
Closed	00885800000700
Closed	00374700006100
Closed	00374700006100
Closed	30051300301100
Closed	28062600202200
Closed	30062600300600
Closed	00891100002500
Closed	32063200305000
Closed	00394403904400
Closed	32063200304700
Closed	00394403904100
Closed	28060800100100
Closed	00394400102500
Closed	00394400103800
Closed	00394400105000
Closed	00919900009901
Closed	00919900010001
Closed	30062100201500
Closed	30062100201800
Closed	00919900009701
Closed	00919900009801
Closed	32090700400300
Closed	00626200000500
Closed	00626200000400
Closed	29063300302400
Closed	28070800301600
Closed	29050200303500

Accessory Dwelling Units

Index # - File Name: 1.0022 - Single Family Dwellings Data\_Snohomish County.pdf

Closed	00924300000700
Closed	00924300000900
Closed	00926600000300
Closed	00926600000400
Closed	00926600000500
Closed	00926600000600
Closed	00926600001000
Closed	00926600001100
Closed	00924500001900
Closed	00924500002000
Closed	00924500006700
Closed	00924500006900
Closed	00924500002500
Closed	00924500002200
Closed	00924100000500
Closed	00924100000600
Closed	00924500007400
Closed	00924500007100
Closed	00924500007200
Closed	00924100000100
Closed	00924100000200
Closed	00924100000300
Closed	00923900000700
Closed	00579100005001
Closed	00926400002400
Closed	00926500000400
Closed	30072900300700
Closed	30072900300800
Closed	30072900300900
Closed	30072900301000
Closed	30072900301100
Closed	30072900301200
Closed	30072900402000
Closed	30072900401900
Closed	30072900201200
Closed	30072900201700
Closed	30072900202100
Closed	30072900402600
Closed	30072900402400
Closed	30072900402100
Closed	00471300005700
Closed	28061400101200
Closed	28061400102100
Closed	27061700202700
Closed	30062900302800
Closed	00927800000200
Closed	00928600003600

Accessory Dwelling Units

Index # - File Name: 1.0022 - Single Family Dwellings Data\_Snohomish County.pdf

Closed	00928600003200
Closed	00928600004100
Closed	00928600003800
Closed	00928600002400
Closed	00928600002300
Closed	00513700008701
Closed	31063200102900
Closed	30063500100300
Closed	30063500102300
Closed	30063500102200
Closed	29060200400600
Closed	29060200401000
Closed	29060200401200
Closed	00928500000900
Closed	00928500000600
Closed	30050100103500
Closed	00928500001300
Closed	30073200201600
Closed	30073200201800
Closed	30072900402700
Closed	30073200202200
Closed	30073200101500
Closed	30073200101700
Closed	30073200100800
Closed	30072900301600
Closed	00930500001800
Closed	00930500001900
Closed	28050300300500
Closed	28050300300500
Closed	00916900000900
Closed	00466700004800
Closed	30060600301700
Closed	00585200005400
Closed	00914000004900
Closed	00914100000200
Closed	00914100001100
Closed	00914100001200
Closed	00914000001400
Closed	00914000005500
Closed	28073300202800
Closed	00914000001100
Closed	28072800201400
Closed	00913400001800
Closed	00912600004600
Closed	27061700301000
Closed	00912600004400
Closed	00912600004800

Accessory Dwelling Units

Index # - File Name: 1.0022 - Single Family Dwellings Data\_Snohomish County.pdf

Closed	00912600003800
Closed	00912600003700
Closed	00912600003600
Closed	00912600003400
Closed	00494600301000
Closed	00911800000500
Closed	27071100301200
Closed	32053400101000
Closed	00916900002400
Closed	00916900002500
Closed	00916900002600
Closed	00916900002700
Closed	00916900000300
Closed	00916900000400
Closed	00916900002900
Closed	00916900003000
Closed	00916900003200
Closed	32053300100600
Closed	28050300300500
Closed	00466200003800
Closed	00917300002100
Closed	00917300002200
Closed	00917300001700
Closed	00917300001800
Closed	00917300001900
Closed	00917600004500
Closed	00917600004600
Closed	00917600004300
Closed	29051100107200
Closed	29051100107300
Closed	00917600001900
Closed	00917600004200
Closed	00917600002000
Closed	00917600002100
Closed	00917600002400
Closed	00917600002500
Closed	00917600002600
Closed	00917600002700
Closed	00917600001200
Closed	00917600002900
Closed	00917600003500
Closed	00917600003700
Closed	00917600004000
Closed	00917600004100
Closed	31050900400400
Closed	32042300402500
Closed	00919300003600

Accessory Dwelling Units

Index # - File Name: 1.0022 - Single Family Dwellings Data\_Snohomish County.pdf

Closed	32091700100300
Closed	00897900002100
Closed	28060300201600
Closed	32062500301100
Closed	29061600103100
Closed	00401100012800
Closed	00427100006000
Closed	00542900002400
Closed	28061400305700
Closed	30060500100900
Closed	30060500101000
Closed	00401100008200
Closed	00401000011900
Closed	00401100014100
Closed	00401000007700
Closed	32040400103000
Closed	29073200100800
Closed	00900700000600
Closed	00901200000300
Closed	32042100102500
Closed	32052200102700
Closed	00911300001800
Closed	00911300002600
Closed	30062300401500
Closed	00499100103100
Closed	00910400000100
Closed	00910400000200
Closed	30050200201500
Closed	32090700400100
Closed	00590700023701
Closed	27051000408500
Closed	29070500201500
Closed	27091400200600
Closed	30062800302200
Closed	00907500000400
Closed	00467100002400
Closed	00907500000100
Closed	00630600001300
Closed	29063000400400
Closed	32081200100700
Closed	28072000202800
Closed	27051400401000
Closed	31062600200300
Closed	00373002204101
Closed	27062200201900
Closed	00948600003700
Closed	00948600003600

Accessory Dwelling Units

Index # - File Name: 1.0022 - Single Family Dwellings Data\_Snohomish County.pdf

Closed	00948600003500
Closed	00948600003400
Closed	00947600000600
Closed	00947600000700
Closed	00947600000800
Closed	00947600001000
Closed	00947600001100
Closed	00947600001200
Closed	00947600001300
Closed	00947600001500
Closed	00948600001200
Closed	00948600001300
Closed	00948600002300
Closed	00948600002400
Closed	00948600002500
Closed	00948600002600
Closed	00948600000800
Closed	00948600000900
Closed	00948600003100
Closed	00948600001500
Closed	00948600001600
Closed	00948600002200
Closed	00948600001700
Closed	00948600001800
Closed	00948600001900
Closed	00948600002000
Closed	00948600002100
Closed	00948600002700
Closed	00948600002800
Closed	31043500402100
Closed	00947800000100
Closed	00947800000200
Closed	00947800000300
Closed	00947800000600
Closed	00947800000700
Closed	00947800000900
Closed	00947800001000
Closed	00947800001100
Closed	00947800001200
Closed	00947800001300
Closed	00947800001400
Closed	00947800001500
Closed	00947800001600
Closed	00947800001700
Closed	00947800001800
Closed	00947800001900
Closed	00947800002100

Accessory Dwelling Units

Index # - File Name: 1.0022 - Single Family Dwellings Data\_Snohomish County.pdf

Closed	00947800002200
Closed	00947800002300
Closed	00947800002400
Closed	00947800000800
Closed	00948300000200
Closed	00948300000300
Closed	00948300000400
Closed	00948300000500
Closed	00948300000600
Closed	00948300000700
Closed	28060300404300
Closed	00947900000100
Closed	00947900000200
Closed	00947900000300
Closed	00947900000400
Closed	00947900000500
Closed	00947900000600
Closed	00947900000700
Closed	00947900000800
Closed	00947900000900
Closed	00947900001000
Closed	00533200001000
Closed	00953300000100
Closed	00947600001700
Closed	00947600001800
Closed	00947600002600
Closed	00947600002700
Closed	00947600003200
Closed	00947600003700
Closed	00947600003900
Closed	00947600003800
Closed	00947600004000
Closed	00947600004200
Closed	00947600000300
Closed	00947600004700
Closed	00947600004900
Closed	00953300000300
Closed	00953300000600
Closed	00953300000700
Closed	00953300000800
Closed	00953300000900
Closed	00953300001000
Closed	00953300001100
Closed	00953300001200
Closed	00953300001300
Closed	00953300001400
Closed	00953300001500



Accessory Dwelling Units

Index # - File Name: 1.0022 - Single Family Dwellings Data\_Snohomish County.pdf

Closed	00953300001600
Closed	00953300001700
Closed	00953300001900
Closed	00953300002000
Closed	00953300002100
Closed	00953300002200
Closed	00953300002300
Closed	00953300002400
Closed	00953300002500
Closed	00953300002600
Closed	00953300002700
Closed	00953300002800
Closed	00953300003100
Closed	00953300003200
Closed	00953300003300
Closed	00373002205105
Closed	00372801001510
Closed	00372801001511
Closed	32100800200900
Closed	00490700000100
Closed	00617300201503
Closed	32061700200400
Closed	00949700000100
Closed	00949700000300
Closed	00949700000400
Closed	00944900000800
Closed	00490000000800
Closed	28061100203100
Closed	32061700200300
Closed	30052500304200
Closed	00944900000100
Closed	00944900000200
Closed	00944900000300
Closed	00944900000400
Closed	00943200003000
Closed	00943200003100
Closed	00943200002700
Closed	00944900000600
Closed	00945400000100
Closed	00945400000200
Closed	00945400000300
Closed	00945400000400
Closed	00945400000500
Closed	00945400000600
Closed	00945400000700
Closed	00945400000800
Closed	00945400000900

Accessory Dwelling Units

Index # - File Name: 1.0022 - Single Family Dwellings Data\_Snohomish County.pdf

Closed	00945400001000
Closed	00945400001100
Closed	00945400001200
Closed	00945400001300
Closed	00945400001400
Closed	00945400001500
Closed	00945400001600
Closed	00945400001700
Closed	00945400001800
Closed	00945400001900
Closed	00945400002000
Closed	00945400002100
Closed	00945400002200
Closed	00945400002300
Closed	00945400002400
Closed	00945400002500
Closed	00945400002600
Closed	00945400002700
Closed	00945400002800
Closed	00945400002900
Closed	00945400003000
Closed	00945400003100
Closed	00945500000100
Closed	00945500000200
Closed	00945500000300
Closed	00945500000400
Closed	00945500000500
Closed	00945500000600
Closed	00945500000700
Closed	00945500000800
Closed	00945500000900
Closed	00945500001000
Closed	00945500001100
Closed	00945500001200
Closed	00945500001300
Closed	00945500001400
Closed	00945500001500
Closed	00945500001600
Closed	00945500001700
Closed	30062400401800
Closed	27043000404900
Closed	31053200201600
Closed	00943200001700
Closed	00943200001900
Closed	00943200002000
Closed	00943200002200
Closed	00943200002400

Accessory Dwelling Units

Index # - File Name: 1.0022 - Single Family Dwellings Data\_Snohomish County.pdf

Closed	00947300000100
Closed	00947300000200
Closed	00947300000300
Closed	00947300000400
Closed	00947300000500
Closed	00947300000700
Closed	00947300000800
Closed	00947300000900
Closed	00947300001000
Closed	00947300001100
Closed	00947300001200
Closed	00947300001300
Closed	00947300001400
Closed	00947300001500
Closed	00947300001600
Closed	00947300001700
Closed	00947300001800
Closed	00629600010402
Closed	30060300100300
Closed	00943200000700
Closed	00943200000800
Closed	00943200001000
Closed	00942600001000
Closed	00942900000700
Closed	30070800200800
Closed	00403900021801
Closed	30061800402700
Closed	28063200200900
Closed	28063200201000
Closed	28063200104300
Closed	28063200104400
Closed	28060800102600
Closed	00951200000100
Closed	00951200000200
Closed	00951200000400
Closed	00951200000600
Closed	00951200000700
Closed	00951200000800
Closed	00950800000900
Closed	00950800001000
Closed	00950800001100
Closed	00950800001200
Closed	00950800001300
Closed	00948900000100
Closed	00948900000200
Closed	00948900000300
Closed	00948900000400

Accessory Dwelling Units

Index # - File Name: 1.0022 - Single Family Dwellings Data\_Snohomish County.pdf

Closed	00948900000500
Closed	00948900000600
Closed	00948900000700
Closed	00948900000800
Closed	00948900000900
Closed	00948900001000
Closed	00948900001100
Closed	00948900001200
Closed	00948900001300
Closed	00948900001400
Closed	00948900001500
Closed	00948900001600
Closed	00509200201700
Closed	30040800401500
Closed	29062300100700
Closed	00951500000100
Closed	00951500000200
Closed	00951500000300
Closed	00951500000400
Closed	00951500000500
Closed	00951500000600
Closed	00951500000700
Closed	00951500000800
Closed	00951500000900
Closed	00951500001000
Closed	00951500001100
Closed	00951500001200
Closed	00951500001300
Closed	00951500001400
Closed	00951500001500
Closed	00951500001600
Closed	00951500001700
Closed	00951500001800
Closed	00951500001900
Closed	00951500002000
Closed	00951500002100
Closed	00951500002200
Closed	00951500002300
Closed	00951500002400
Closed	00951500002500
Closed	00951500002600
Closed	00951500002700
Closed	00951500003700
Closed	00951500003800
Closed	00951500007100
Closed	00951500007200
Closed	00951500007300

Accessory Dwelling Units

Index # - File Name: 1.0022 - Single Family Dwellings Data\_Snohomish County.pdf

Closed	00951500007400
Closed	00951500007500
Closed	00951500007600
Closed	00951500007700
Closed	00951500007900
Closed	00951500008000
Closed	00951500008100
Closed	00951500008200
Closed	00951500008300
Closed	00951500008400
Closed	00951500008500
Closed	00951500008600
Closed	00951500008700
Closed	00951500008800
Closed	00951500008900
Closed	00951500009000
Closed	00951500009100
Closed	00951500009200
Closed	00951500009300
Closed	00951500009400
Closed	00951500009500
Closed	00951500009600
Closed	00951500009700
Closed	00951500009800
Closed	00951500009900
Closed	00951500010000
Closed	00951500010100
Closed	00951500010200
Closed	00951500010300
Closed	00951500010400
Closed	00951500010500
Closed	00951500010600
Closed	00951500010700
Closed	00951500010800
Closed	00951500010900
Closed	00951500011000
Closed	00951500011100
Closed	00951500011200
Closed	00951500011300
Closed	00951500011400
Closed	00951500011500
Closed	00951500011600
Closed	00951500011700
Closed	31040400301000
Closed	00949000000100
Closed	00949000000300
Closed	00949000000400

Accessory Dwelling Units

Index # - File Name: 1.0022 - Single Family Dwellings Data\_Snohomish County.pdf

Closed	0094900000500
Closed	0094900000600
Closed	0094900000700
Closed	0094900000800
Closed	0094900000900
Closed	0094900001000
Closed	0094900001100
Closed	0094900001200
Closed	0094900001400
Closed	0094900001500
Closed	0094900001600
Closed	0094900001800
Closed	0094900002100
Closed	0094900002200
Closed	0094900002300
Closed	0094900002400
Closed	0094900002500
Closed	0094900002600
Closed	0040090000600
Closed	00394400306100
Closed	00951500012000
Closed	00951500012100
Closed	00951500012200
Closed	00951500013700
Closed	00951500013800
Closed	0042680000700
Closed	00952300000100
Closed	00952300000200
Closed	00952300000300
Closed	00952300000400
Closed	00952300000500
Closed	00952300000600
Closed	00952300000700
Closed	00952300000900
Closed	00952300001000
Closed	00952300001100
Closed	00952300001200
Closed	00952300001300
Closed	00952300001900
Closed	00952300002000
Closed	00952300002100
Closed	00952300002200
Closed	00952300002300
Closed	00952300002400
Closed	00952300002500
Closed	00952300002600
Closed	00952300002700

Accessory Dwelling Units

Index # - File Name: 1.0022 - Single Family Dwellings Data\_Snohomish County.pdf

Closed	00952300002800
Closed	00952300002900
Closed	00952300003000
Closed	00952300003100
Closed	00952300003200
Closed	00952300003300
Closed	00952300003400
Closed	00952300003500
Closed	00951900000100
Closed	00951900000200
Closed	00951900000300
Closed	00952300004500
Closed	00952300004600
Closed	00952300004700
Closed	00551400000100
Closed	00492000301400
Closed	29061600201700
Closed	00492000304300
Closed	00625300003700
Closed	00448600000402
Closed	32042000102300
Closed	00951600000100
Closed	00951600000200
Closed	00951600000300
Closed	00951600000400
Closed	00951600000500
Closed	00951600000600
Closed	00951600000700
Closed	00951600000800
Closed	00951600000900
Closed	00951600001000
Closed	00951600004400
Closed	00951600004500
Closed	00951600004600
Closed	00951600004700
Closed	00951600004800
Closed	00951600004900
Closed	00951600005000
Closed	00951600005100
Closed	00951600005200
Closed	00951600005300
Closed	00951600005400
Closed	00951600005500
Closed	00951600005600
Closed	00951600005700
Closed	00951800000100
Closed	00951800000200

Accessory Dwelling Units

Index # - File Name: 1.0022 - Single Family Dwellings Data\_Snohomish County.pdf

Closed	0095180000300
Closed	0095180000400
Closed	0095180000500
Closed	0095180000600
Closed	0095180000700
Closed	0095180000800
Closed	0095180000900
Closed	0095180001000
Closed	0095180001200
Closed	0095180001300
Closed	0095180001400
Closed	0095180001500
Closed	0095180001600
Closed	0095180001700
Closed	0095180001800
Closed	00489100009600
Closed	00489100009500
Closed	30062400100600
Closed	00513700008702
Closed	00493200200200
Closed	00944800000200
Closed	00944800000300
Closed	00944800000400
Closed	00944800000500
Closed	00944800000600
Closed	00944800000700
Closed	00944800000800
Closed	00941900002000
Closed	00941900002100
Closed	00941900002200
Closed	00942300002200
Closed	00942300001600
Closed	00942300001700
Closed	00942300001300
Closed	00941900001800
Closed	00942300000900
Closed	00942300000600
Closed	00942300000200
Closed	00942300000300
Closed	00942300000400
Closed	00941700001700
Closed	27062100303300
Closed	27062100303400
Closed	27062100303500
Closed	00942000006000
Closed	00942000006300
Closed	00942000006400



Accessory Dwelling Units

Index # - File Name: 1.0022 - Single Family Dwellings Data\_Snohomish County.pdf

Closed	00942000006500
Closed	00942000006600
Closed	00942000006700
Closed	00942000006800
Closed	00942000006900
Closed	00942000007000
Closed	00942000007100
Closed	00942000007200
Closed	00942000007300
Closed	00942000007400
Closed	00942000003600
Closed	00942000003700
Closed	00942000003800
Closed	00942000003900
Closed	00942000004000
Closed	00942000004100
Closed	00942000004200
Closed	00942000004400
Closed	00942000004500
Closed	00942000004600
Closed	00942000004700
Closed	00942000004800
Closed	00942000004900
Closed	00942000005000
Closed	00942000005100
Closed	00942000005200
Closed	00394507001102
Closed	00942000005300
Closed	00942000005400
Closed	00942000005500
Closed	00942000005600
Closed	00942000003300
Closed	32051300302100
Closed	00942000003000
Closed	00940900003600
Closed	00940900003800
Closed	00940900003900
Closed	00942000001200
Closed	00942000001300
Closed	00942000001400
Closed	00942000001500
Closed	00942000001600
Closed	00942000001700
Closed	00942000001800
Closed	00942000001900
Closed	00942000002000
Closed	00942000002100

Accessory Dwelling Units

Index # - File Name: 1.0022 - Single Family Dwellings Data\_Snohomish County.pdf

Closed	00942000002200
Closed	00942000002300
Closed	29061300203000
Closed	00945600000100
Closed	00945600000200
Closed	00945600000300
Closed	00945600000400
Closed	00945600000500
Closed	00945600000600
Closed	00945600000700
Closed	00945600000800
Closed	00945600000900
Closed	00945600001000
Closed	00945600001100
Closed	00945600001200
Closed	00945600001300
Closed	00945600001400
Closed	00945600001500
Closed	00945600001600
Closed	00945600001700
Closed	00945600001800
Closed	00945600001900
Closed	00945600002000
Closed	00945600002100
Closed	00945600002200
Closed	00945600002300
Closed	00945600002400
Closed	00945600002500
Closed	00945600002600
Closed	00945600002700
Closed	00945600002800
Closed	00945600002900
Closed	00945600003000
Closed	00945600003100
Closed	00945600003200
Closed	00945600003300
Closed	00945600003400
Closed	00945600003500
Closed	00945600003600
Closed	00945600003700
Closed	00945600003800
Closed	00945600003900
Closed	00945600004000
Closed	00945600004100
Closed	00945600004200
Closed	00945600004300
Closed	00945600004400

Accessory Dwelling Units

Index # - File Name: 1.0022 - Single Family Dwellings Data\_Snohomish County.pdf

Closed	00945600004500
Closed	00945600004600
Closed	00945600004700
Closed	00945600004800
Closed	00945600004900
Closed	00945600005000
Closed	00945600005100
Closed	00945600005200
Closed	00945600005300
Closed	00590700017202
Closed	00590700017203
Closed	00590700017204
Closed	00945300000100
Closed	00945300000200
Closed	00945300000300
Closed	00945300000400
Closed	00945300000500
Closed	00945300000600
Closed	00945300000700
Closed	00945300000800
Closed	00945300000900
Closed	00482900008300
Closed	00946800000100
Closed	00946800000200
Closed	00946800000300
Closed	00946800000400
Closed	00946800000600
Closed	00946800000700
Closed	00946800000800
Closed	00946800000900
Closed	00946800001000
Closed	00945900000100
Closed	00945900000200
Closed	00945900000300
Closed	00945900000400
Closed	00945900000500
Closed	00945900000600
Closed	00945900000700
Closed	00945900000800
Closed	00945900000900
Closed	00945900001000
Closed	00945900001100
Closed	00945900001200
Closed	00945900001400
Closed	00945900001500
Closed	00945900001600
Closed	00945900001700

Accessory Dwelling Units

Index # - File Name: 1.0022 - Single Family Dwellings Data\_Snohomish County.pdf

Closed	00945900001800
Closed	00945900001900
Closed	00945900002000
Closed	00945900002200
Closed	00945900002300
Closed	00945900002800
Closed	00945900002900
Closed	00945900003000
Closed	00945900003200
Closed	00945900003300
Closed	00945900003400
Closed	00945900003500
Closed	00945900003600
Closed	00945900003700
Closed	00945900003800
Closed	00945900003900
Closed	00945900004000
Closed	00945900004100
Closed	00945900004200
Closed	00945900004300
Closed	00945900004400
Closed	00945900004500
Closed	00945900004600
Closed	00945900004700
Closed	00945900004800
Closed	00945900004900
Closed	00945900005000
Closed	00945900005100
Closed	00945900005200
Closed	00945900005300
Closed	00945900005400
Closed	00945900005500
Closed	00945900005600
Closed	00945900005700
Closed	00958200000100
Closed	00958200000200
Closed	00958200000300
Closed	00958200000400
Closed	00958200000500
Closed	00958200000600
Closed	00958200000700
Closed	00958200000800
Closed	00958200000900
Closed	00958200001000
Closed	00958200001100
Closed	00958200001200
Closed	00958200001300

Accessory Dwelling Units

Index # - File Name: 1.0022 - Single Family Dwellings Data\_Snohomish County.pdf

Closed	00958200001400
Closed	00958200001500
Closed	00958200002700
Closed	00958200002600
Closed	00958200002500
Closed	00958200002400
Closed	00958200002300
Closed	00958200002200
Closed	00958200001600
Closed	00958200001700
Closed	00958200001800
Closed	00958200001900
Closed	00958200002000
Closed	00958200002100
Closed	00940900002700
Closed	27051000101700
Closed	00940900001300
Closed	00940900001400
Closed	00940900001900
Closed	00940900002000
Closed	00940900002100
Closed	00940900002200
Closed	00940900002300
Closed	00940900002400
Closed	00940900002500
Closed	00941700001000
Closed	28083400400200
Closed	29051100105300
Closed	00941700000800
Closed	00940900000100
Closed	00940900000200
Closed	00940900000300
Closed	00940900000400
Closed	00940900000500
Closed	00940900000600
Closed	00940900000700
Closed	00940900000800
Closed	00940900000900
Closed	00941700000500
Closed	00941700000600
Closed	29062100404200
Closed	29061400300600
Closed	00941200005000
Closed	00941200005100
Closed	00941200002300
Closed	00941200002400
Closed	00939600002500

Accessory Dwelling Units

Index # - File Name: 1.0022 - Single Family Dwellings Data\_Snohomish County.pdf

Closed	28062600201900
Closed	00945800000100
Closed	00945800000200
Closed	00945800000300
Closed	00945800000400
Closed	00945800000500
Closed	00945800000600
Closed	00945800000700
Closed	00945800000800
Closed	00942600000100
Closed	00942600000200
Closed	00942600000300
Closed	00942600000400
Closed	00942600000500
Closed	00942600000600
Closed	00942600000700
Closed	00942600000900
Closed	00941700000100
Closed	00941700000200
Closed	00941200004500
Closed	00941200003100
Closed	00941200003300
Closed	00941200000100
Closed	00941200000200
Closed	00941200000300
Closed	00941200000400
Closed	00941200000500
Closed	00941200000600
Closed	00941200000700
Closed	00941200000800
Closed	00941200000900
Closed	00941200001000
Closed	00941200001100
Closed	00941200001200
Closed	00941200001300
Closed	00941200001400
Closed	00941200001500
Closed	00941200001600
Closed	00941200001700
Closed	00941200001800
Closed	00941200001900
Closed	00941200002000
Closed	00941200002100
Closed	32042600302100
Closed	32042600302200
Closed	32042600302300
Closed	30061600300900

Accessory Dwelling Units

Index # - File Name: 1.0022 - Single Family Dwellings Data\_Snohomish County.pdf

Closed	27053500400900
Closed	00941300000600
Closed	00941300000700
Closed	00939700002600
Closed	00939600002300
Closed	00939600000500
Closed	00939600000600
Closed	00939600000700
Closed	00939600000800
Closed	00939600000900
Closed	00939700002000
Closed	00939700001600
Closed	00939700001200
Closed	00939700001000
Closed	29053600102000
Closed	00373800600904
Closed	00373800600904
Closed	00939700000700
Closed	00939700000800
Closed	00373800600904
Closed	00373800600904
Closed	00373800600904
Closed	00373800600904
Closed	00373800600904
Closed	00373800600904
Closed	00373800600904
Closed	00373800600904
Closed	00373800600904
Closed	00373800600904
Closed	00373800600904
Closed	00939800002100
Closed	00939800002200
Closed	00939800000900
Closed	00939800001900
Closed	00939800000200
Closed	00939800000300
Closed	00944400005300
Closed	00941400000200
Closed	00944400005100
Closed	00944400004900
Closed	00944400002700
Closed	00944400004600
Closed	00944400004700
Closed	00944400003000
Closed	00944400003100
Closed	00944400003200
Closed	00944400003300
Closed	00944400003400

Accessory Dwelling Units

Index # - File Name: 1.0022 - Single Family Dwellings Data\_Snohomish County.pdf

Closed	00944400003500
Closed	00944400003600
Closed	00944400003700
Closed	00944400003800
Closed	00944400003900
Closed	00944400004200
Closed	00944400004300
Closed	00944400004400
Closed	00944400001100
Closed	00944400001200
Closed	00944400001300
Closed	00944400001400
Closed	00944400001500
Closed	00944400001600
Closed	00944400001700
Closed	00944400001800
Closed	00944400001900
Closed	00944400002000
Closed	00944400002100
Closed	00944400002200
Closed	00944400002300
Closed	00944400002400
Closed	00944400002500
Closed	00944400003000
Closed	00944400004000
Closed	00940000001700
Closed	00940000001800
Closed	00940000000600
Closed	00940000000700
Closed	00940000000800
Closed	00937500001200
Closed	00937500001300
Closed	00937500002000
Closed	32063600202600
Closed	00959700002900
Closed	00937500000600
Closed	00950600001800
Closed	00950600001900
Closed	00950600002000
Closed	00950600002100
Closed	00950600002300
Closed	00950600002400
Closed	00950600002500
Closed	00950600005300
Closed	00950600005400
Closed	00950600005600
Closed	00950600005800



Accessory Dwelling Units

Index # - File Name: 1.0022 - Single Family Dwellings Data\_Snohomish County.pdf

Closed	00950600005900
Closed	00950600006000
Closed	00950600006100
Closed	00950600006200
Closed	00950600006300
Closed	00950600006400
Closed	00950600006500
Closed	32061000101400
Closed	32061000100800
Closed	00950600004000
Closed	00950600004200
Closed	00950600004300
Closed	00950600004400
Closed	00950600004600
Closed	00950600004700
Closed	00950600000400
Closed	00950600000500
Closed	00950600000600
Closed	00950600000800
Closed	00950600000900
Closed	00950600001000
Closed	00950600001100
Closed	00950600001300
Closed	00950600001500
Closed	00950600001600
Closed	00950600001700
Closed	30052100112300
Closed	32043600100700
Closed	00950600000100
Closed	27051000302900
Closed	00471300005800
Closed	00394401304300
Closed	00936400000100
Closed	28063200302200
Closed	00372801400108
Closed	00372801400110
Closed	31060600202100
Closed	00936100000400
Closed	00936100000500
Closed	00936100000600
Closed	00937100001200
Closed	30052200212000
Closed	29061500400600
Closed	00936100001400
Closed	00935100008000
Closed	00935100008100
Closed	00935100008200

Accessory Dwelling Units

Index # - File Name: 1.0022 - Single Family Dwellings Data\_Snohomish County.pdf

Closed	00403800001202
Closed	00935100007900
Closed	00935100007800
Closed	00935100007700
Closed	00935100007600
Closed	00935100007500
Closed	00935100007400
Closed	00935100007300
Closed	00935100007200
Closed	00935100007100
Closed	00935100007000
Closed	00935100006900
Closed	00935100006800
Closed	00935100006700
Closed	00935100004400
Closed	00935100004600
Closed	00935100006200
Closed	00935100006100
Closed	00935100005800
Closed	00935100005700
Closed	00935100005600
Closed	00935100005500
Closed	00935100005400
Closed	00935100005300
Closed	00935100005200
Closed	00935100005100
Closed	00935100005000
Closed	00935100004900
Closed	00935100004800
Closed	00935100006500
Closed	00935100006400
Closed	00389400300102
Closed	00389400300103
Closed	00937100000500
Closed	00934000008400
Closed	00937100000300
Closed	00934000009500
Closed	00934000009600
Closed	00934000009700
Closed	00934000009800
Closed	00934000009900
Closed	00934000010000
Closed	00934000010100
Closed	00934000010200
Closed	00934000010300
Closed	00934000010400
Closed	28083500407200

Accessory Dwelling Units

Index # - File Name: 1.0022 - Single Family Dwellings Data\_Snohomish County.pdf

Closed	0093400009300
Closed	0093400009200
Closed	0093400008900
Closed	0093700002400
Closed	0093700001300
Closed	0051900000800
Closed	0093490001800
Closed	0093490001900
Closed	0093490002000
Closed	0093490001100
Closed	0093490001200
Closed	0093490001300
Closed	0093490001400
Closed	0093490001500
Closed	0093490001600
Closed	0093700001800
Closed	0093330000100
Closed	31050300300400
Closed	00403800007802
Closed	0093490000700
Closed	0093490000800
Closed	0093490000900
Closed	0093450001600
Closed	0093450002400
Closed	0093450001300
Closed	0093450001400
Closed	32042300103900
Closed	0093450000100
Closed	0093450000200
Closed	0093450000700
Closed	0093450000800
Closed	0093450004400
Closed	0093450004500
Closed	0093450004600
Closed	0093450004700
Closed	0093430000100
Closed	0093430000200
Closed	0093430000300
Closed	0093430000400
Closed	0093450003300
Closed	0093450003400
Closed	0093450003500
Closed	0093450003700
Closed	0093450003800
Closed	0093450004100
Closed	0093450004200
Closed	0093450004300

Accessory Dwelling Units

Index # - File Name: 1.0022 - Single Family Dwellings Data\_Snohomish County.pdf

Closed	00934500002100
Closed	00934500002000
Closed	00934500001900
Closed	00934500001800
Closed	00934500000500
Closed	00934500000600
Closed	00936000000400
Closed	00936000000500
Closed	00936000000600
Closed	00936000000200
Closed	31042400200100
Closed	00934600000300
Closed	00934600000500
Closed	00933000003000
Closed	00933000004200
Closed	00933000004300
Closed	00933000003300
Closed	00933000003700
Closed	009344000008800
Closed	009344000008900
Closed	009344000009000
Closed	009344000009100
Closed	009344000009200
Closed	009344000009300
Closed	00932900000400
Closed	00933000001400
Closed	009344000006500
Closed	009344000006600
Closed	009344000006700
Closed	009344000006800
Closed	009344000006900
Closed	009344000007000
Closed	009344000007100
Closed	009344000007200
Closed	009344000007300
Closed	009344000007400
Closed	009344000007500
Closed	009344000004900
Closed	009344000005000
Closed	009344000005100
Closed	009344000005200
Closed	009344000005300
Closed	009344000005400
Closed	009344000005500
Closed	009344000005600
Closed	009344000005700
Closed	009344000005800

Accessory Dwelling Units

Index # - File Name: 1.0022 - Single Family Dwellings Data\_Snohomish County.pdf

Closed	00934400005900
Closed	00934400006000
Closed	00934400006100
Closed	00934400006200
Closed	00934400006300
Closed	00934400006400
Closed	00934400007600
Closed	00934400007700
Closed	00934400007800
Closed	00934400007900
Closed	00934400008000
Closed	00934400008100
Closed	00934400000200
Closed	00934400000300
Closed	00934400000400
Closed	00934400000500
Closed	00934400000600
Closed	00934400000700
Closed	00934400000800
Closed	00934400000900
Closed	00934400001000
Closed	00934400001100
Closed	00934400001200
Closed	00934400001300
Closed	00934400001600
Closed	00934400001700
Closed	00934400001800
Closed	00934400001900
Closed	00934400002000
Closed	00934400002100
Closed	00934400002200
Closed	00934400002300
Closed	00934400002400
Closed	00934400002500
Closed	00934400002600
Closed	00934400002700
Closed	00934400002800
Closed	00934400002900
Closed	00934400003000
Closed	00934400003100
Closed	00934400003200
Closed	00934400003300
Closed	00934400003400
Closed	00934400003500
Closed	00934400003600
Closed	00934400003700
Closed	00934400003800

Accessory Dwelling Units

Index # - File Name: 1.0022 - Single Family Dwellings Data\_Snohomish County.pdf

Closed	29051100107500
Closed	29051100107600
Closed	30062400302600
Closed	30062400302800
Closed	30062400303300
Closed	30062400303000
Closed	30062400303200
Closed	00933300003200
Closed	00933300004400
Closed	00933300004500
Closed	00933300004600
Closed	00933300003300
Closed	00933300003400
Closed	00933300003500
Closed	00933300003600
Closed	00933300003000
Closed	00933300004100
Closed	00933300004200
Closed	00933300000300
Closed	00932200000300
Closed	00931400000200
Closed	00931400000300
Closed	00931400000400
Closed	00931400000500
Closed	00933300000700
Closed	00933300000800
Closed	00933300000900
Closed	00933300001000
Closed	00932200000700
Closed	00932200000800
Closed	00932200001000
Closed	00932200000900
Closed	00932200001100
Closed	00932200001200
Closed	31041100202000
Closed	29051200407100
Closed	31040300200100
Closed	00952800000100
Closed	00952800000200
Closed	00952800000300
Closed	00952800000400
Closed	00952800000500
Closed	00952800000600
Closed	00952800000800
Closed	00952800000900
Closed	00952800001000
Closed	00952800001100

Accessory Dwelling Units

Index # - File Name: 1.0022 - Single Family Dwellings Data\_Snohomish County.pdf

Closed	00952800001200
Closed	00952800001300
Closed	00952800001400
Closed	00952800001500
Closed	00952800001600
Closed	00952800001700
Closed	00952800001800
Closed	00952800001900
Closed	00952800002000
Closed	00952800002100
Closed	00952800002200
Closed	00952800002300
Closed	00952800002400
Closed	00952800002500
Closed	00952800002600
Closed	00953000000100
Closed	00953000000200
Closed	00953000000300
Closed	00953000000400
Closed	00953000000500
Closed	00953000000600
Closed	00953000000700
Closed	00953000000800
Closed	00953000000900
Closed	00953000001000
Closed	00953000001100
Closed	00953000001200
Closed	00953000001300
Closed	00953000001400
Closed	00953000001500
Closed	00953000001600
Closed	00953000001700
Closed	00953000001800
Closed	00953000001900
Closed	00953000002000
Closed	00953000002100
Closed	00953000002200
Closed	00953000002300
Closed	00953000002400
Closed	00953000002500
Closed	00953000002600
Closed	00953000002700
Closed	00953000002800
Closed	00953000002900
Closed	00953000003000
Closed	00953000003100
Closed	00953000003200

Accessory Dwelling Units

Index # - File Name: 1.0022 - Single Family Dwellings Data\_Snohomish County.pdf

Closed	00953000003300
Closed	00953000003400
Closed	00953000003500
Closed	00953000003600
Closed	00953000003700
Closed	00953000003800
Closed	29052500201400
Closed	29052500201500
Closed	29052500201600
Closed	00952200000100
Closed	00952200000200
Closed	00952200000300
Closed	00952200000400
Closed	00952200000500
Closed	00952200000600
Closed	00952200000700
Closed	00952200000800
Closed	00952200000900
Closed	00952200001000
Closed	00952200001100
Closed	00952200001200
Closed	00952200001300
Closed	00952200001400
Closed	00952200001500
Closed	00952200001600
Closed	00952200001700
Closed	00952200001800
Closed	00952200001900
Closed	00952200002000
Closed	00952200002100
Closed	00952200002200
Closed	00952200002300
Closed	00952200002400
Closed	00952200002500
Closed	00952200002600
Closed	00952200002700
Closed	00952200002800
Closed	00952200002900
Closed	00952200003000
Closed	00951600001700
Closed	00951600001800
Closed	00951600001900
Closed	00951600002000
Closed	00951600002100
Closed	00951600002200
Closed	00951600002300
Closed	00951600002400



Accessory Dwelling Units

Index # - File Name: 1.0022 - Single Family Dwellings Data\_Snohomish County.pdf

Closed	00951600002500
Closed	00951600002600
Closed	00951600002700
Closed	00951600002800
Closed	00951600002900
Closed	00951600003000
Closed	00951600003100
Closed	00951600003200
Closed	00951600003300
Closed	00951600003400
Closed	00951600003500
Closed	00951600003600
Closed	00951600003700
Closed	00951600003800
Closed	00951600003900
Closed	00951600004000
Closed	00951600001200
Closed	00951600001300
Closed	00951600001400
Closed	00951600001500
Closed	29062600303700
Closed	00466900001900
Closed	00952000000100
Closed	00952000000200
Closed	00952000000300
Closed	00952000000400
Closed	00952000000500
Closed	00952000000600
Closed	00952000000700
Closed	00952000000800
Closed	00952000000900
Closed	00394404607800
Closed	31041100201600
Closed	00954900000100
Closed	00954900000200
Closed	00954900000400
Closed	00954900000600
Closed	00954900001500
Closed	00954900001600
Closed	00954900001700
Closed	00954900001800
Closed	00954900001900
Closed	00954900002000
Closed	32042000206400
Closed	28063300101300
Closed	00952700000100
Closed	00952700000200

Accessory Dwelling Units

Index # - File Name: 1.0022 - Single Family Dwellings Data\_Snohomish County.pdf

Closed	00952700000300
Closed	00952700000400
Closed	00952700000500
Closed	00952700000600
Closed	00952700000700
Closed	00952700000800
Closed	00954900001000
Closed	32062800302900
Closed	00953900000100
Closed	00953900000200
Closed	00953900000300
Closed	00953900000400
Closed	00953900001800
Closed	00394509600200
Closed	00953900001900
Closed	00953900002000
Closed	00953900002100
Closed	00953900002200
Closed	00953900002300
Closed	00953900002400
Closed	00953900002500
Closed	00953900002600
Closed	00953900002700
Closed	00953900002800
Closed	00953900002900
Closed	00953900003000
Closed	00953900003100
Closed	00953900004000
Closed	00952400000100
Closed	00952400000200
Closed	00952400000300
Closed	00952400000400
Closed	00952400000500
Closed	00952400000600
Closed	00952400000700
Closed	00952400000800
Closed	00952400000900
Closed	00952400001000
Closed	00952400001100
Closed	00952400001200
Closed	00952400001300
Closed	00952400001400
Closed	00952400001500
Closed	00952400001600
Closed	00952400001700
Closed	00952400001800
Closed	00952400003000

Accessory Dwelling Units

Index # - File Name: 1.0022 - Single Family Dwellings Data\_Snohomish County.pdf

Closed	00952400003100
Closed	00952400003200
Closed	00952400003300
Closed	00952400003400
Closed	00952400003500
Closed	00952400003600
Closed	00952400003700
Closed	00952400003800
Closed	00952400003900
Closed	00952400004000
Closed	00952400004900
Closed	00952400005100
Closed	00952400005200
Closed	00562800001400
Closed	00482900002600
Closed	00953900003300
Closed	00953900003500
Closed	00952400007300
Closed	00952400007400
Closed	00952400007500
Closed	00952400007600
Closed	00952400007700
Closed	00952400007800
Closed	00952400007900
Closed	32071200100900
Closed	00952400005000
Closed	28053300106700
Closed	28053300106900
Closed	28053300107000
Closed	00952400004600
Closed	28063200201100
Closed	28063200201200
Closed	28063200201400
Closed	28081800301200
Closed	00956100000200
Closed	00956100000300
Closed	32090800401200
Closed	29063300402100
Closed	00373000100608
Closed	00954800001300
Closed	00954800001400
Closed	00954800001500
Closed	00954800001600
Closed	00954800001700
Closed	00954800001800
Closed	00954800001900
Closed	00954800002000

Accessory Dwelling Units

Index # - File Name: 1.0022 - Single Family Dwellings Data\_Snohomish County.pdf

Closed	00954800002100
Closed	00954800002200
Closed	00954800002300
Closed	00954800002400
Closed	00954800002500
Closed	00954800002600
Closed	00954800002700
Closed	00954800002800
Closed	00954800002900
Closed	00954800003000
Closed	00954800003100
Closed	00954800003200
Closed	00954800003300
Closed	00954800003400
Closed	00954800003500
Closed	00954800003600
Closed	00954800003700
Closed	00954800000100
Closed	00954800000200
Closed	00954800000300
Closed	00954800000400
Closed	00954800000500
Closed	00954800000600
Closed	00954800000700
Closed	00954800000800
Closed	00954800000900
Closed	00954800001000
Closed	00954800001100
Closed	00954800001200
Closed	00480401706401
Closed	00953700000200
Closed	00953700000300
Closed	00953700000500
Closed	00953700000800
Closed	00953700000600
Closed	00953700000700
Closed	30051500204200
Closed	30051500204300
Closed	30040100101400
Closed	00556600009700
Closed	31043500402800
Closed	00953700000100
Closed	30060700203000
Closed	28070600303200
Closed	30050300305000
Closed	30050300305300
Closed	28061100204000

Accessory Dwelling Units

Index # - File Name: 1.0022 - Single Family Dwellings Data\_Snohomish County.pdf

Closed	30050600302400
Closed	30050600302500
Closed	30050600302600
Closed	30050600302700
Closed	00373101200607
Closed	00373101200608
Closed	00373101200609
Closed	28070600303100
Closed	00958000000800
Closed	00958000000900
Closed	00403800013601
Closed	28063300101400
Closed	00958000001200
Closed	00958000001500
Closed	00958000001600
Closed	00958000001700
Closed	00958000002300
Closed	00958000002500
Closed	00958000002600
Closed	00958000002700
Closed	00958000002800
Closed	00958000002900
Closed	00958000003000
Closed	00958000003100
Closed	00958000003200
Closed	00958000003300
Closed	00958000003400
Closed	00958000003500
Closed	00958000003600
Closed	00958000003700
Closed	00958000003800
Closed	00955700001000
Closed	00955700001100
Closed	00955700001200
Closed	00955700001300
Closed	00955700001400
Closed	00955700001500
Closed	00955700001600
Closed	00955700001700
Closed	00955700001800
Closed	00955700001900
Closed	00955700002000
Closed	00955700002100
Closed	00955700002200
Closed	00955700002300
Closed	00955700002400
Closed	00955700002500

Accessory Dwelling Units

Index # - File Name: 1.0022 - Single Family Dwellings Data\_Snohomish County.pdf

Closed	00955700002600
Closed	00955700002700
Closed	00955700002800
Closed	00955700003000
Closed	00955700003100
Closed	00955700003200
Closed	00955700003300
Closed	00955700003400
Closed	00955700003500
Closed	00955700003600
Closed	00955700003700
Closed	00955700003800
Closed	00955700003900
Closed	00955700004000
Closed	00955700004100
Closed	00955700004200
Closed	00955700004300
Closed	00955700004400
Closed	00955700004500
Closed	00955700004600
Closed	00955700004700
Closed	00955700004800
Closed	00955700004900
Closed	00955700005000
Closed	00955700005100
Closed	00955700005300
Closed	00955700005400
Closed	00955700005500
Closed	00955700005600
Closed	00955700005700
Closed	30081500202300
Closed	27063400401600
Closed	00958000004300
Closed	32062800300100
Closed	28070500301000
Closed	27072900400400
Closed	00394403402900
Closed	00955700000100
Closed	00955700000200
Closed	00955700000300
Closed	00955700000400
Closed	00487000000100
Closed	00955700000700
Closed	00955700000800
Closed	00373700400901
Closed	00956700000200
Closed	00956700000300

Accessory Dwelling Units

Index # - File Name: 1.0022 - Single Family Dwellings Data\_Snohomish County.pdf

Closed	00956700001100
Closed	00956700001200
Closed	00956700001300
Closed	00956700001400
Closed	00551500002300
Closed	27061900202800
Closed	00956700001900
Closed	29063200400800
Closed	00957100000200
Closed	00957100000300
Closed	00957100000400
Closed	00957100000500
Closed	00957100000600
Closed	30060700202200
Closed	00956700002100
Closed	00956700002200
Closed	00956700002300
Closed	00956000000600
Closed	00956000000700
Closed	00956000000900
Closed	00956000001600
Closed	00956000002700
Closed	00956200000100
Closed	00956200000500
Closed	00956200000600
Closed	00956200000700
Closed	00956200000800
Closed	00956200000900
Closed	00956200001100
Closed	00956200001200
Closed	00466200007400
Closed	00956200001700
Closed	00956200001900
Closed	00956200002000
Closed	00956200002200
Closed	00513700005512
Closed	00513700005514
Closed	00509300000202
Closed	32063300202500
Closed	27063400101200
Closed	27071800104100
Closed	00958700001100
Closed	00958700001400
Closed	00958700002700
Closed	00958700002800
Closed	00958700002900
Closed	00958700003000

Accessory Dwelling Units

Index # - File Name: 1.0022 - Single Family Dwellings Data\_Snohomish County.pdf

Closed	00958700001700
Closed	00958700003200
Closed	00958700003500
Closed	00958700004000
Closed	00958700004400
Closed	30051400100400
Closed	29060300201000
Closed	29063300203600
Closed	29063300302300
Closed	29063300302700
Closed	00958800001700
Closed	32062800303400
Closed	32042200401800
Closed	00957000000100
Closed	00957000000200
Closed	00957000000300
Closed	00957000000400
Closed	00957000000500
Closed	00957000000600
Closed	00957000000700
Closed	00957000000800
Closed	00957000000900
Closed	00957000001000
Closed	00957000001100
Closed	00957000001200
Closed	00957000001300
Closed	00957000001400
Closed	00957000001500
Closed	00957000001600
Closed	00957000001700
Closed	00957000001800
Closed	00957000001900
Closed	00957000002000
Closed	00957000002100
Closed	00957000002200
Closed	00957000002300
Closed	00957000002400
Closed	00957000002500
Closed	00957000002600
Closed	00957000002700
Closed	00373700300702
Closed	30052100112400
Closed	00956600000500
Closed	00956600000600
Closed	00956600000900
Closed	00956600002600
Closed	30061800200500



Accessory Dwelling Units

Index # - File Name: 1.0022 - Single Family Dwellings Data\_Snohomish County.pdf

Closed	00957300000100
Closed	00957300000200
Closed	00957300000300
Closed	00957300000400
Closed	00957300000500
Closed	00957300000600
Closed	00957300000700
Closed	00957300000800
Closed	00957300000900
Closed	00957300001000
Closed	00957300001100
Closed	00957300001200
Closed	00957300001300
Closed	00957300002000
Closed	00957300002100
Closed	00957300002400
Closed	00957300002500
Closed	00957300002600
Closed	00957300002700
Closed	00957300002800
Closed	00957300001500
Closed	00957300001600
Closed	00957300001700
Closed	00957300003000
Closed	00957300002200
Closed	00957300002300
Closed	00629500000900
Closed	30062900400600
Closed	32063500200500
Closed	32063500200600
Closed	32063500200700
Closed	00509300000403
Closed	00629500000300
Closed	00604100000807
Closed	27061900202300
Closed	27061900202400
Closed	27061900202500
Closed	003853000009100
Closed	00959100000300
Closed	00959100000400
Closed	00959100000500
Closed	00959100000600
Closed	00466200003300
Closed	27051100105900
Closed	00959100000100
Closed	00959100002100
Closed	00959100002200

Accessory Dwelling Units

Index # - File Name: 1.0022 - Single Family Dwellings Data\_Snohomish County.pdf

Closed	00959100002300
Closed	00959100002900
Closed	00959100003000
Closed	31041000401700
Closed	31041300401200
Closed	28072800303800
Closed	01000800000100
Closed	01000800000300
Closed	01000800000500
Closed	01000200000100
Closed	01000200000200
Closed	01000200000300
Closed	01000200000400
Closed	01000200000500
Closed	01000200000600
Closed	01000200000700
Closed	01000200000800
Closed	01000200000900
Closed	01000200001000
Closed	01000200001300
Closed	01000200001400
Closed	01000200001500
Closed	01000200001600
Closed	01000200001700
Closed	01000200001800
Closed	01000200001900
Closed	01000200002800
Closed	01000200002900
Closed	01000200003000
Closed	01000200003100
Closed	01000200003200
Closed	01000200004400
Closed	01000200004500
Closed	01000200004600
Closed	01000200004700
Closed	01000200004900
Closed	01000200005000
Closed	01000200005100
Closed	01000700000300
Closed	01000700000500
Closed	01000700002500
Closed	01000700002600
Closed	01000700002900
Closed	01000700003000
Closed	01000700003300
Closed	01000700003700
Closed	01000700003800

Accessory Dwelling Units

Index # - File Name: 1.0022 - Single Family Dwellings Data\_Snohomish County.pdf

Closed	01000700001600
Closed	01000700001900
Closed	01000700002300
Closed	00535300001200
Closed	00535300001200
Closed	00535300001200
Closed	01000200002000
Closed	01000200002100
Closed	01000200002200
Closed	00959300000100
Closed	00959300000200
Closed	00959300000300
Closed	00959300000400
Closed	00959300000500
Closed	00959300000600
Closed	00959300000700
Closed	01000200002400
Closed	01000200002600
Closed	00959300001000
Closed	01001000000100
Closed	01001000000200
Closed	01001000000300
Closed	01000300000100
Closed	01000300000200
Closed	01002100000800
Closed	01002100001000
Closed	01000300003200
Closed	00440300001700
Closed	00490100003100
Closed	28062700400800
Closed	01002000001200
Closed	01002000001900
Closed	01002000002700
Closed	01002000002800
Closed	00509500001004
Closed	00509500001005
Closed	00509500001006
Closed	00509500001007
Closed	01002000002500
Closed	01006600000500
Closed	01006600000600
Closed	01006600000700
Closed	01002500200100
Closed	01002500200200
Closed	01002500200300
Closed	01002500200400
Closed	01002500200500

Accessory Dwelling Units

Index # - File Name: 1.0022 - Single Family Dwellings Data\_Snohomish County.pdf

Closed	01002500200600
Closed	01002500100100
Closed	01002500100200
Closed	01002500100400
Closed	01002500100600
Closed	01011200000200
Closed	01011200000300
Closed	00394400201600
Closed	01004400000900
Closed	01004400000300
Closed	01004400000400
Closed	01004400000600
Closed	01004400000700
Closed	01004400002900
Closed	01004400003000
Closed	01004400003200
Closed	01004400003300
Closed	01004400004700
Closed	01004400004800
Closed	01004400004400
Closed	01004400004500
Closed	31051600401700
Closed	31051600401800
Closed	32052700101000
Closed	27071800400500
Closed	00604800000704
Closed	32040400300200
Closed	01005200000700
Closed	01005200000800
Closed	01005200000900
Closed	01005200001000
Closed	00373701700100
Closed	29062000200900
Closed	01002000001800
Closed	31051600401900
Closed	01005200001200
Closed	01005200001300
Closed	01005200001400
Closed	01005200001600
Closed	01005200001700
Closed	01005200001800
Closed	01005200001900
Closed	01005200002000
Closed	01005200002100
Closed	01005200002200
Closed	01005200002300
Closed	00372901000919

Accessory Dwelling Units

Index # - File Name: 1.0022 - Single Family Dwellings Data\_Snohomish County.pdf

Closed	28072300200900
Closed	27051800200600
Closed	28071800200500
Closed	00394405005700
Closed	28062900402700
Closed	28062900402600
Closed	30051500308400
Closed	00373700201703
Closed	00373700201705
Closed	00499100101300
Closed	29060200300700
Closed	32041100200500
Closed	29061600402000
Closed	01006200000100
Closed	01006200000200
Closed	01006200000400
Closed	01006200000500
Closed	01006200000600
Closed	01006200000700
Closed	01006200000800
Closed	01006200000900
Closed	01006200001000
Closed	01006200001100
Closed	29072900300200
Closed	31042000202700
Closed	30051000205100
Closed	30051000205200
Closed	30051000205300
Closed	30051000205400
Closed	00513700005516
Closed	28051100301800
Closed	01007000000100
Closed	01007000000200
Closed	01007000000300
Closed	01007000000400
Closed	01007000000500
Closed	01007000000600
Closed	01007000000700
Closed	01007000000800
Closed	01007000000900
Closed	01007000001000
Closed	01007000001100
Closed	01006700000200
Closed	01006700000400
Closed	01006700000500
Closed	01006700000700
Closed	01006700000900

Accessory Dwelling Units

Index # - File Name: 1.0022 - Single Family Dwellings Data\_Snohomish County.pdf

Closed	01006700001100
Closed	01006700001200
Closed	01006700001300
Closed	01006700001500
Closed	28073200102500
Closed	28073200101500
Closed	01006900000200
Closed	01006900000300
Closed	01006900000400
Closed	01006900000500
Closed	01006900000600
Closed	01006900000700
Closed	01006900000800
Closed	01006900000900
Closed	01006900001000
Closed	01006900001100
Closed	01006900001200
Closed	01006900001300
Closed	01006900001400
Closed	01006900002700
Closed	01006900002800
Closed	01006900002900
Closed	01006900003000
Closed	01006900003100
Closed	01006900003200
Closed	01006900003300
Closed	01006900003400
Closed	01006900003500
Closed	01006900003600
Closed	01006900003700
Closed	01006900003800
Closed	01006900003900
Closed	01006900004000
Closed	01006900004100
Closed	01006900004200
Closed	01006900004300
Closed	01006900004500
Closed	01006900004600
Closed	01006900004700
Closed	01006900004800
Closed	01006900004900
Closed	01006900005000
Closed	01006900005100
Closed	01006900005200
Closed	01007500000100
Closed	01007500000200
Closed	01007500000400

Accessory Dwelling Units

Index # - File Name: 1.0022 - Single Family Dwellings Data\_Snohomish County.pdf

Closed	01007500000500
Closed	01007500000600
Closed	01007500000700
Closed	01007500000800
Closed	01007500000900
Closed	01007500001000
Closed	01007500001100
Closed	01007500001200
Closed	01007500001300
Closed	01007500001400
Closed	01007500001500
Closed	01007500001600
Closed	01007500001700
Closed	01007500001800
Closed	01007500001900
Closed	01007500002000
Closed	01004400004600
Closed	01004800002500
Closed	01004800002000
Closed	01004800002100
Closed	01004800002200
Closed	01004800002300
Closed	01004800002900
Closed	01004800003000
Closed	01004800003100
Closed	01010500000500
Closed	01010500000600
Closed	01004800003300
Closed	01004800003400
Closed	01010500001200
Closed	01005600000100
Closed	01005600000200
Closed	01005600000300
Closed	01005600000400
Closed	01005600000500
Closed	01005600000600
Closed	01005600000700
Closed	01005600000800
Closed	01005600000900
Closed	01005600001000
Closed	01005600001100
Closed	01005600001200
Closed	01005600001300
Closed	01005600001400
Closed	01005600001500
Closed	01005600001600
Closed	01005600001700

Accessory Dwelling Units

Index # - File Name: 1.0022 - Single Family Dwellings Data\_Snohomish County.pdf

Closed	01005600001800
Closed	01005600001900
Closed	01005600002000
Closed	01005600002100
Closed	01005600002200
Closed	01005600002300
Closed	01005600002400
Closed	01005600002500
Closed	01005600002600
Closed	01005600002700
Closed	01005600002800
Closed	01005600002900
Closed	01005600003000
Closed	01005600003100
Closed	01005600003200
Closed	01005600003300
Closed	01005600003400
Closed	01005200000100
Closed	01005200000200
Closed	01005200000300
Closed	01005200000500
Closed	01004800000100
Closed	01004800000200
Closed	01004800000300
Closed	01004800000400
Closed	01004800000500
Closed	01004800000600
Closed	01004800000700
Closed	01004800000800
Closed	01004800000900
Closed	01004800001000
Closed	01004800001200
Closed	01004800001300
Closed	01004800001400
Closed	01004800001500
Closed	01004800001600
Closed	01004800001700
Closed	01004800001800
Closed	01004400003400
Closed	01004400003500
Closed	01004400003600
Closed	01004400003700
Closed	01004400003800
Closed	01004400003900
Closed	01004400004000
Closed	01004400004100
Closed	01004400004200



Accessory Dwelling Units

Index # - File Name: 1.0022 - Single Family Dwellings Data\_Snohomish County.pdf

Closed	01004400004300
Closed	01004400003100
Closed	01004400000800
Closed	01004400000500
Closed	01004400000100
Closed	01004400000200
Closed	01004800003600
Closed	01004800003700
Closed	01004800003800
Closed	01004800003900
Closed	01004800004000
Closed	01004800004100
Closed	01004800004200
Closed	01004800004300
Closed	01004800004400
Closed	01004800004500
Closed	01004800004600
Closed	01004800004700
Closed	01004800004800
Closed	01004800004900
Closed	01004800005000
Closed	01004800005100
Closed	01004800005200
Closed	01004800005300
Closed	01004800005400
Closed	01004800005500
Closed	01004800005600
Closed	01004800005700
Closed	01004800005800
Closed	01004800005900
Closed	01004800006000
Closed	01004800006100
Closed	01004800006200
Closed	01004800006300
Closed	01004800006400
Closed	01004800006500
Closed	01004800006600
Closed	01004800006700
Closed	01004800006800
Closed	01004800006900
Closed	01004800007000
Closed	01004800007100
Closed	01004800007200
Closed	01004800007300
Closed	01004800007400
Closed	01004800007500
Closed	01004800007600

Accessory Dwelling Units

Index # - File Name: 1.0022 - Single Family Dwellings Data\_Snohomish County.pdf

Closed	01004800007700
Closed	01004800007800
Closed	01004800007900
Closed	01004800008000
Closed	01004800008100
Closed	01004800008200
Closed	01010500000100
Closed	01010500000200
Closed	01004400001000
Closed	01004400001100
Closed	01004400001200
Closed	01004400001300
Closed	01004400001400
Closed	01004400001500
Closed	01004400001600
Closed	01004400001700
Closed	01004400001800
Closed	01004400001900
Closed	01004400002000
Closed	01004400002100
Closed	01004400002200
Closed	01004400002300
Closed	01004400002400
Closed	01004400002500
Closed	01004400002600
Closed	01004400002700
Closed	01004400002800
Closed	29061900106800
Closed	27053300111100
Closed	01004500001500
Closed	01004500001600
Closed	01004500000300
Closed	01004500000400
Closed	01004500000500
Closed	01004500000600
Closed	01004500000700
Closed	01004500000800
Closed	01004500000900
Closed	01004500001000
Closed	01002500100500
Closed	01002500100300
Closed	01002500200700
Closed	01002500200900
Closed	01002500201000
Closed	01002500201100
Closed	01002500201200
Closed	01002500201300

Accessory Dwelling Units

Index # - File Name: 1.0022 - Single Family Dwellings Data\_Snohomish County.pdf

Closed	01002500201400
Closed	01002500201500
Closed	01011200000500
Closed	01011200000600
Closed	01011200000700
Closed	01011200000800
Closed	01011200000900
Closed	01011200001000
Closed	01011200001100
Closed	01011200001200
Closed	01011200001300
Closed	01011200001400
Closed	01011200001500
Closed	01011200001600
Closed	01011200001700
Closed	01011200001800
Closed	01011200001900
Closed	01011200002000
Closed	01011200002100
Closed	01011200002200
Closed	01011200002300
Closed	01011200002500
Closed	01011200002600
Closed	01011200002700
Closed	01011200002800
Closed	01011200002900
Closed	01011200003000
Closed	01011200003100
Closed	00373300501204
Closed	29051300106800
Closed	01004700000100
Closed	01004700000200
Closed	01004700000300
Closed	01004700000400
Closed	01004700000500
Closed	01004700000600
Closed	01004700000700
Closed	01004700000800
Closed	01004700000900
Closed	01004700001000
Closed	01004700001100
Closed	01004700001200
Closed	01004700001300
Closed	01004700001400
Closed	01004700001500
Closed	01004700001600
Closed	01004700001700

Accessory Dwelling Units

Index # - File Name: 1.0022 - Single Family Dwellings Data\_Snohomish County.pdf

Closed	01004700001800
Closed	01004700001900
Closed	01004700002000
Closed	01004700002100
Closed	01004700002200
Closed	01004700002300
Closed	01004700002400
Closed	01004700002500
Closed	01004700002600
Closed	01004700002700
Closed	01004700002800
Closed	01004700002900
Closed	01004700003000
Closed	01004700003100
Closed	01004700003200
Closed	01004700003300
Closed	01004700003400
Closed	01004700003500
Closed	01004700003600
Closed	01004700003700
Closed	01004700003800
Closed	01004700003900
Closed	01004700004000
Closed	01004700004100
Closed	01004700004200
Closed	01004700004300
Closed	01004700004400
Closed	01004700004500
Closed	01004700004600
Closed	01004700004700
Closed	01004700004800
Closed	01004700004900
Closed	01004700005000
Closed	01004700005100
Closed	01004700005200
Closed	01004700005300
Closed	01004700005400
Closed	01004700005500
Closed	01004700005600
Closed	01005100000300
Closed	01005100000400
Closed	01005100000500
Closed	01005100000600
Closed	01005100000700
Closed	01004600000100
Closed	01004600000200
Closed	01004600000300

Accessory Dwelling Units

Index # - File Name: 1.0022 - Single Family Dwellings Data\_Snohomish County.pdf

Closed	0100460000400
Closed	0100460000500
Closed	0100460000600
Closed	0100460000700
Closed	0100460000800
Closed	0100460000900
Closed	0100460001100
Closed	0100460001200
Closed	0100460001300
Closed	0100460001500
Closed	0100460001700
Closed	0100460001800
Closed	0100460001900
Closed	0100460002000
Closed	0100460002100
Closed	0100460002200
Closed	0100660000800
Closed	0100660000900
Closed	0100660001000
Closed	0100660001100
Closed	0100660001200
Closed	0100660001300
Closed	0100660001400
Closed	0100660001500
Closed	0100660001600
Closed	0100660001700
Closed	0100660001800
Closed	0100660001900
Closed	0100660002000
Closed	0100660002100
Closed	0100660002200
Closed	0100660002300
Closed	0100660002400
Closed	0100660002500
Closed	0100660002600
Closed	0100660002700
Closed	0100660002800
Closed	0100660002900
Closed	0100660003000
Closed	0100660003100
Closed	0100660003200
Closed	0100660003300
Closed	0100660003400
Closed	0100660003500
Closed	0100660003600
Closed	0100660003700
Closed	0100660003800

Accessory Dwelling Units

Index # - File Name: 1.0022 - Single Family Dwellings Data\_Snohomish County.pdf

Closed	01006600003900
Closed	01006600004000
Closed	01006600004100
Closed	01006600004200
Closed	01006600004300
Closed	01004300005300
Closed	01004300005400
Closed	01004300005500
Closed	01004300005600
Closed	01004300005700
Closed	01004300005800
Closed	01006600000100
Closed	01006600000200
Closed	01006600000300
Closed	01006600000400
Closed	01002000002600
Closed	27062800103400
Closed	31062900301900
Closed	28053600201100
Closed	28053600201100
Closed	01004300000200
Closed	28062900401000
Closed	31060500101500
Closed	00608200800600
Closed	01004300000400
Closed	01004300000800
Closed	01004300000900
Closed	01004300001000
Closed	01004300001300
Closed	01004300001400
Closed	01004300001700
Closed	01004300001800
Closed	01002000002900
Closed	01002000003000
Closed	30040300401000
Closed	01002000002000
Closed	01002000002100
Closed	01002000002200
Closed	01002000002300
Closed	01002000002400
Closed	01002000001300
Closed	01002000001400
Closed	01002000001500
Closed	01002000001600
Closed	01002000000600
Closed	01002000000900
Closed	01002000001000

Accessory Dwelling Units

Index # - File Name: 1.0022 - Single Family Dwellings Data\_Snohomish County.pdf

Closed	01002000001100
Closed	28051700410400
Closed	28051700410500
Closed	28051700410600
Closed	32041600201100
Closed	29070800101700
Closed	01000400001100
Closed	31052400101400
Closed	27090400303700
Closed	29063500300800
Closed	00394509501500
Closed	01006900001600
Closed	01006900001700
Closed	01006900001800
Closed	01006900001900
Closed	01006900002100
Closed	01006900002200
Closed	01006900002300
Closed	01006700001900
Closed	28070600303300
Closed	01024500000800
Closed	28073300203500
Closed	27062900202000
Closed	29061500102500
Closed	27070500205700
Closed	00490700000800
Closed	00622100000300
Closed	01008300000800
Closed	01008300000900
Closed	01008300002700
Closed	01008300002800
Closed	01008300002900
Closed	01008300003000
Closed	01008300003100
Closed	01008300003200
Closed	01008300003300
Closed	01008300003400
Closed	01008300005800
Closed	01008300005900
Closed	01008300006000
Closed	01008300006100
Closed	01008300006200
Closed	01008300006300
Closed	01008300006400
Closed	01008300006500
Closed	01008300006600
Closed	01008300006700

Accessory Dwelling Units

Index # - File Name: 1.0022 - Single Family Dwellings Data\_Snohomish County.pdf

Closed	01008300006800
Closed	01008300006900
Closed	01008300007000
Closed	01008300007100
Closed	01008300007200
Closed	01008300007300
Closed	01008300007400
Closed	01008300007500
Closed	01008300007600
Closed	01008300007700
Closed	01008300007800
Closed	01008300007900
Closed	32063400401900
Closed	00379500000200
Closed	01008300000100
Closed	01008300000200
Closed	01008300000300
Closed	01008300000500
Closed	01008300000600
Closed	01008300004600
Closed	01008300004700
Closed	01009900000200
Closed	01009900000300
Closed	01009900000400
Closed	01009900000600
Closed	01009900000700
Closed	01009900000800
Closed	01009900001000
Closed	01009900001100
Closed	01009900001300
Closed	01009900001400
Closed	01009900001600
Closed	01009900001700
Closed	01009900001800
Closed	01009900001900
Closed	01009900002100
Closed	00556600004900
Closed	01008500000100
Closed	01008500000200
Closed	01008500000300
Closed	01008500000400
Closed	01008500000500
Closed	01008500000600
Closed	01008500000700
Closed	01008500000800
Closed	01008500000900
Closed	01008500001000



Accessory Dwelling Units

Index # - File Name: 1.0022 - Single Family Dwellings Data\_Snohomish County.pdf

Closed	01008500001100
Closed	01008500001200
Closed	01008500001300
Closed	01008500001400
Closed	01008500001500
Closed	01008500001600
Closed	01008500001700
Closed	01008500001800
Closed	01008500001900
Closed	01008500002100
Closed	01008500002200
Closed	01008500002300
Closed	01008500002400
Closed	01008500002500
Closed	01008500002600
Closed	01008500002700
Closed	01008500002800
Closed	01008500002900
Closed	01008500003000
Closed	01008500003100
Closed	01008500003200
Closed	01008500003300
Closed	01008500003400
Closed	01008500003500
Closed	01008500003600
Closed	01008500003700
Closed	01008500003800
Closed	01008500003900
Closed	01008500004000
Closed	01008500004100
Closed	01008500004200
Closed	01008500004300
Closed	01008500004400
Closed	01008500004500
Closed	01008500004600
Closed	01008500004700
Closed	01008500004800
Closed	01008500004900
Closed	01008500005000
Closed	01008500005100
Closed	01008500005200
Closed	01008500005300
Closed	01008500005400
Closed	01009200000100
Closed	01009200000200
Closed	01009200000300
Closed	01009200000400

Accessory Dwelling Units

Index # - File Name: 1.0022 - Single Family Dwellings Data\_Snohomish County.pdf

Closed	01009200000500
Closed	01009200000600
Closed	01009200000700
Closed	01009200000800
Closed	01009200000900
Closed	01009200001000
Closed	01009200001100
Closed	01009200001200
Closed	01009200001300
Closed	00401000014500
Closed	00394401703301
Closed	27090800103700
Closed	32042200201800
Closed	30051500205100
Closed	30051500205200
Closed	30051500205300
Closed	30051500205400
Closed	30051500205500
Closed	30051500205600
Closed	30051500205700
Closed	30051500205800
Closed	30051500205900
Closed	00373300900110
Closed	00373300900110
Closed	00630600000600
Closed	01009200003300
Closed	01009200003400
Closed	01009200003500
Closed	01009200003600
Closed	01009200003700
Closed	01009200003800
Closed	01009200003900
Closed	01009200004000
Closed	01009200004100
Closed	01009200004200
Closed	01009200004300
Closed	01009200004400
Closed	01009200004500
Closed	01009200004600
Closed	01009200004700
Closed	01009200004800
Closed	01009200004900
Closed	01009200005000
Closed	01009200005100
Closed	01009200005400
Closed	01009200005500
Closed	01009200005600

Accessory Dwelling Units

Index # - File Name: 1.0022 - Single Family Dwellings Data\_Snohomish County.pdf

Closed	01009200005700
Closed	01009200005800
Closed	01009200005900
Closed	00492000302400
Closed	00372801202206
Closed	01009200007500
Closed	01009200007600
Closed	32052100102300
Closed	01008300002400
Closed	28062400404100
Closed	28062400404000
Closed	01009200006600
Closed	01009200006700
Closed	01009200006800
Closed	01009200006900
Closed	01009200007000
Closed	01009200007100
Closed	01009200007200
Closed	01009200007300
Closed	01009200007400
Closed	01009100000100
Closed	01009100000200
Closed	01009100000300
Closed	01009100000400
Closed	01009500001600
Closed	01009500000100
Closed	01009500000200
Closed	01009500000300
Closed	01009500000400
Closed	01009500003500
Closed	01009500003600
Closed	01009500003700
Closed	01009600000100
Closed	01009600000200
Closed	01009600000300
Closed	01009600000400
Closed	01009600000500
Closed	01009600000600
Closed	01009600000700
Closed	01009600000800
Closed	01008900000100
Closed	01008900000200
Closed	01008900000300
Closed	01008900000800
Closed	01008900000900
Closed	01008900001000
Closed	01008900001100

Accessory Dwelling Units

Index # - File Name: 1.0022 - Single Family Dwellings Data\_Snohomish County.pdf

Closed	01008900001200
Closed	01008900001300
Closed	01008900001400
Closed	01008900001500
Closed	01008900001600
Closed	01008900001700
Closed	01008900001800
Closed	01008900001900
Closed	01008900002400
Closed	01008900002500
Closed	01008900002600
Closed	01008900002700
Closed	01008900002800
Closed	01008900002900
Closed	01008900003000
Closed	01008900003100
Closed	01008900003200
Closed	01008900003300
Closed	01008900003400
Closed	01008900003500
Closed	01008900003600
Closed	29061200302000
Closed	32050500301200
Closed	28051700406100
Closed	30062900100900
Closed	00631900003000
Closed	01010000000100
Closed	01010000000200
Closed	01010000000300
Closed	01010000000400
Closed	01010000000500
Closed	01010000000600
Closed	01010000000700
Closed	01010000000800
Closed	01010000000900
Closed	01010000001000
Closed	01010000001100
Closed	01010000001200
Closed	01010000001300
Closed	01010000001400
Closed	01010000001500
Closed	01010000001600
Closed	01010000001700
Closed	01010000001800
Closed	01010000001900
Closed	01010000002000
Closed	01010000002100

Accessory Dwelling Units

Index # - File Name: 1.0022 - Single Family Dwellings Data\_Snohomish County.pdf

Closed	01010000002200
Closed	00579100000102
Closed	32090700102600
Closed	27062200300300
Closed	27062200300300
Closed	01008900003800
Closed	01008900003900
Closed	01008900004000
Closed	01008900004100
Closed	00394405101500
Closed	00394405101600
Closed	32040500100200
Closed	01009500001300
Closed	01009500001400
Closed	01008900000500
Closed	01008900000600
Closed	01008900002100
Closed	30061500301200
Closed	01005900000400
Closed	01005900000500
Closed	01005900000600
Closed	01005900000700
Closed	01005900000800
Closed	01005900000900
Closed	01009800000900
Closed	01009800001000
Closed	01009800002000
Closed	01009800002100
Closed	01009800002200
Closed	01009800002300
Closed	01009800002400
Closed	01009800002500
Closed	01009800002600
Closed	01009800002700
Closed	01009800002800
Closed	01009800002900
Closed	01009800003000
Closed	01009800000500
Closed	01009800003700
Closed	01009800003800
Closed	01009800004100
Closed	01009800004500
Closed	01009800004600
Closed	32052200200300
Closed	00958000009000
Closed	00958000009100
Closed	00958000009200

Accessory Dwelling Units

Index # - File Name: 1.0022 - Single Family Dwellings Data\_Snohomish County.pdf

Closed	0095800009300
Closed	0095800009400
Closed	0095800009500
Closed	0095800009600
Closed	0095800009700
Closed	0095800009800
Closed	0095800009900
Closed	0095800010000
Closed	0095800010100
Closed	0095800010200
Closed	0095800010300
Closed	0095800010400
Closed	0095800010500
Closed	0095800010600
Closed	0095800010700
Closed	0095800010800
Closed	0095800010900
Closed	0095800011000
Closed	0095800011100
Closed	0095800011200
Closed	0095800011300
Closed	0095800011400
Closed	0095800011500
Closed	0095800004900
Closed	0095800005000
Closed	0095800005100
Closed	0095800005200
Closed	0095800005300
Closed	0095800005400
Closed	0095800005500
Closed	0095800005600
Closed	0095800005700
Closed	0095800005800
Closed	0095800005900
Closed	0095800006000
Closed	0095800006100
Closed	0095800007800
Closed	0095800007900
Closed	0095800008000
Closed	0095800008100
Closed	0095800008200
Closed	0095800008300
Closed	0095800008400
Closed	0095800008500
Closed	0095800008600
Closed	0095800008700
Closed	0095800012300

Accessory Dwelling Units

Index # - File Name: 1.0022 - Single Family Dwellings Data\_Snohomish County.pdf

Closed	00958000012400
Closed	00958000012500
Closed	00958000012600
Closed	00958000012700
Closed	00958000012800
Closed	00958000012900
Closed	00958000013000
Closed	00958000013100
Closed	00958000013200
Closed	00958000013300
Closed	00958000013400
Closed	01010100000800
Closed	01010100000900
Closed	01010100001000
Closed	01010100001100
Closed	01010100001200
Closed	01010100001300
Closed	01010100001400
Closed	01010100001500
Closed	01010100001600
Closed	01010100001700
Closed	01010100001800
Closed	01010100001900
Closed	01010100002000
Closed	01010100002100
Closed	01010100002200
Closed	01009800000300
Closed	28063200104700
Closed	27091400200400
Closed	28073300203000
Closed	01010100002400
Closed	01010100002500
Closed	01010100002600
Closed	01010100002700
Closed	01010100002800
Closed	01010100002900
Closed	01010100003000
Closed	01010100003100
Closed	01010100003200
Closed	01000300003300
Closed	01000300003400
Closed	01000400000900
Closed	01000400000500
Closed	01000400000700
Closed	01000400000200
Closed	01000400000300
Closed	01002100000900

Accessory Dwelling Units

Index # - File Name: 1.0022 - Single Family Dwellings Data\_Snohomish County.pdf

Closed	01000300000300
Closed	01000300000400
Closed	01000300000500
Closed	01000300000600
Closed	01000300000700
Closed	01000300000800
Closed	01000300000900
Closed	01000300001000
Closed	01000300001100
Closed	01000300001200
Closed	01000300001300
Closed	01000300001400
Closed	01000300001500
Closed	01000300001600
Closed	01000300001700
Closed	01000300001800
Closed	01000300001900
Closed	01000300002000
Closed	01000300002100
Closed	01000300002200
Closed	01000300002300
Closed	01000300002400
Closed	01000300002500
Closed	01000300002600
Closed	01000300002700
Closed	01000300002800
Closed	01000300002900
Closed	01000300003000
Closed	01000300003100
Closed	01002100000100
Closed	01002100000200
Closed	01002100000300
Closed	01002100000400
Closed	01002100000500
Closed	01002100000600
Closed	01002100000700
Closed	00959300001100
Closed	00959300001200
Closed	01000200002700
Closed	01002200000500
Closed	01002200000600
Closed	00959300000800
Closed	00959300000900
Closed	01002200000100
Closed	01002200000200
Closed	01002200000300
Closed	01000200003300



Accessory Dwelling Units

Index # - File Name: 1.0022 - Single Family Dwellings Data\_Snohomish County.pdf

Closed	01000200003400
Closed	01000200003500
Closed	01000200003600
Closed	01000200003700
Closed	01000200003800
Closed	01000200003900
Closed	01000200004000
Closed	01000200004100
Closed	01000200004200
Closed	01000200004300
Closed	28072300201000
Closed	01000200001100
Closed	01000200001200
Closed	01000800000600
Closed	01000800000400
Closed	01000800000200
Closed	00419500001311
Closed	30063600301600
Closed	01003700003400
Closed	01003700003500
Closed	01003700003600
Closed	01003700003700
Closed	01003700003800
Closed	01003700003900
Closed	01003700004000
Closed	01003700004100
Closed	01003700004200
Closed	01003700004300
Closed	01003700004400
Closed	01003700004500
Closed	01003700004600
Closed	01003700004700
Closed	01003700004800
Closed	01003700002700
Closed	01003700002800
Closed	01003700002900
Closed	01003700003000
Closed	01003700003100
Closed	01003700003200
Closed	01003700005000
Closed	01003700005100
Closed	01003700005200
Closed	01003700005300
Closed	01003700005400
Closed	01003700005700
Closed	01003700006700
Closed	01003700006800

Accessory Dwelling Units

Index # - File Name: 1.0022 - Single Family Dwellings Data\_Snohomish County.pdf

Closed	01003700006900
Closed	01003700007000
Closed	01003700007100
Closed	01003700007200
Closed	01003700007300
Closed	01003700007400
Closed	01003700007500
Closed	01003700007600
Closed	01003700007700
Closed	01003700007800
Closed	01003700007900
Closed	01003700008000
Closed	01003700008100
Closed	01003700008200
Closed	01003700008300
Closed	01003700008400
Closed	01003700008500
Closed	01003700008600
Closed	01003700008700
Closed	01003700008800
Closed	01003700008900
Closed	01003700009000
Closed	01003700009100
Closed	01003700009200
Closed	01003700009300
Closed	01003700009400
Closed	01003700009500
Closed	01003700009600
Closed	01003700009700
Closed	01003700009800
Closed	01003700009900
Closed	01003700010000
Closed	01003700010100
Closed	01003700010200
Closed	01003700010300
Closed	01003700010400
Closed	01003700010500
Closed	01003700010600
Closed	01003700010700
Closed	01003700010800
Closed	01003700010900
Closed	01003700011000
Closed	01003700011100
Closed	01003700011200
Closed	01003700011300
Closed	01003700011400
Closed	01003700011500

Accessory Dwelling Units

Index # - File Name: 1.0022 - Single Family Dwellings Data\_Snohomish County.pdf

Closed	01003700011600
Closed	01003700011700
Closed	01003700011800
Closed	01003700011900
Closed	01003700012000
Closed	01003700012100
Closed	01003700012200
Closed	01003700012400
Closed	01003700012500
Closed	01003700012600
Closed	01003700012700
Closed	01003700012800
Closed	01003700012900
Closed	01003700013000
Closed	01003700013100
Closed	01003700013200
Closed	00959200000600
Closed	00959200000700
Closed	00959200000800
Closed	00959200000900
Closed	00959200001000
Closed	00959200000500
Closed	29070900201200
Closed	00959200000300
Closed	00959100002400
Closed	00959100002500
Closed	00959100002600
Closed	00959100002700
Closed	00959100000200
Closed	00959100000700
Closed	00959100000800
Closed	00959100000900
Closed	00959100001000
Closed	00959100001100
Closed	00959100001200
Closed	00959100001300
Closed	00959100001400
Closed	00959100001500
Closed	00959100001600
Closed	00959100001700
Closed	00959100001800
Closed	00959100001900
Closed	00959100002000
Closed	01001700000200
Closed	01001700000300
Closed	01001700000400
Closed	01001700000500

Accessory Dwelling Units

Index # - File Name: 1.0022 - Single Family Dwellings Data\_Snohomish County.pdf

Closed	01001700000600
Closed	01001700000700
Closed	01001700000800
Closed	01001700000900
Closed	01001700001000
Closed	01001700001100
Closed	01001700001200
Closed	01001700001300
Closed	01001700001400
Closed	01001700001700
Closed	01001700002400
Closed	01001700002500
Closed	01001700002600
Closed	27071100400100
Closed	31041200300400
Closed	00957300001900
Closed	00957300002900
Closed	00957300001400
Closed	00956600003000
Closed	00956600001200
Closed	00956600001800
Closed	00956600001900
Closed	00956600002000
Closed	00956600002100
Closed	00956600002200
Closed	00956600002300
Closed	00956600002400
Closed	00956600002500
Closed	00956600000700
Closed	00956600000800
Closed	00956600000100
Closed	00956600000200
Closed	00958800003100
Closed	00958800003200
Closed	00958800003300
Closed	00958800003400
Closed	00958800003500
Closed	00958800003600
Closed	00925100000300
Closed	00925100000200
Closed	00925100000100
Closed	30052100112500
Closed	00958800001800
Closed	00958800001900
Closed	00958800002000
Closed	00958800002100
Closed	00958800002200

Accessory Dwelling Units

Index # - File Name: 1.0022 - Single Family Dwellings Data\_Snohomish County.pdf

Closed	00958800002300
Closed	29063200402200
Closed	29063200402300
Closed	29063200402400
Closed	29063200402500
Closed	29063200402600
Closed	29063200402900
Closed	00958800002600
Closed	00958800002700
Closed	00958800002800
Closed	00958800003800
Closed	00958800003900
Closed	00958800004000
Closed	00958800004100
Closed	00958800004200
Closed	00958800004300
Closed	00958800004400
Closed	00958800004500
Closed	00958800004600
Closed	00958800004700
Closed	00373002201303
Closed	00373002201303
Closed	00373002201303
Closed	00373002201303
Closed	00373002201303
Closed	00373002201303
Closed	00373002201303
Closed	00373002201303
Closed	00373002201303
Closed	00373002201303
Closed	29063200400700
Closed	29063200400900
Closed	29063200401600
Closed	29063200401800
Closed	29063200401900
Closed	29063300203700
Closed	29063300203500
Closed	32051500301300
Closed	00958800000100
Closed	00958800000200
Closed	00958800000300
Closed	00958800000400
Closed	00958800000500
Closed	00958800000600
Closed	00958800000700
Closed	00958800000800
Closed	00958800000900
Closed	00958800001000

Accessory Dwelling Units

Index # - File Name: 1.0022 - Single Family Dwellings Data\_Snohomish County.pdf

Closed	00958800001100
Closed	00958800001200
Closed	00958800001300
Closed	00958800001400
Closed	00958800001500
Closed	00958800001600
Closed	29070900300900
Closed	00958700003900
Closed	00958700004600
Closed	00958700004700
Closed	00958700004100
Closed	00958700004200
Closed	00958700003600
Closed	00958700003700
Closed	00958700003100
Closed	00958700001900
Closed	00958700002000
Closed	00958700002100
Closed	00958700002200
Closed	00958700002300
Closed	00958700002400
Closed	00958700001500
Closed	00958700001600
Closed	00958700001200
Closed	00958700001300
Closed	00958700000700
Closed	00958700000800
Closed	00958700000900
Closed	00958700001000
Closed	00590700000500
Closed	00590700002001
Closed	28050300404600
Closed	00958700000100
Closed	00958700000200
Closed	00958700000300
Closed	00958700000400
Closed	00958700000500
Closed	28083400401100
Closed	01000600000200
Closed	00423700001200
Closed	00956200002100
Closed	00956200001800
Closed	00394403904700
Closed	00956200001300
Closed	00956200001400
Closed	00956200001500
Closed	00956200001600

Accessory Dwelling Units

Index # - File Name: 1.0022 - Single Family Dwellings Data\_Snohomish County.pdf

Closed	00956200001000
Closed	00956200000200
Closed	00956200000300
Closed	00956200000400
Closed	00956000002200
Closed	29051100103600
Closed	00956000000200
Closed	00956700002000
Closed	27061900202900
Closed	27061900202600
Closed	27061900202700
Closed	31043500201300
Closed	00956700001500
Closed	00956700001600
Closed	00956700001700
Closed	00956700001800
Closed	00956700000400
Closed	00956700000500
Closed	00956700000600
Closed	00956700000700
Closed	00956700000800
Closed	00956700000900
Closed	00956700001000
Closed	00955700000900
Closed	00955700000500
Closed	00955700000600
Closed	32042600102400
Closed	00958000004400
Closed	00958000004500
Closed	00958000004600
Closed	00958000004700
Closed	00958000004800
Closed	00958000003900
Closed	00958000004000
Closed	00958000004100
Closed	00958000004200
Closed	00958000001800
Closed	00958000001900
Closed	00958000002000
Closed	00958000002100
Closed	00958000002200
Closed	00958000001300
Closed	00958000001400
Closed	27060800300700
Closed	00513700003402
Closed	00604100001302
Closed	00957400000100

Accessory Dwelling Units

Index # - File Name: 1.0022 - Single Family Dwellings Data\_Snohomish County.pdf

Closed	00957400000200
Closed	00957400000300
Closed	00608100100302
Closed	31042400100200
Closed	00616900002300
Closed	00958300000100
Closed	00958300000200
Closed	00958300000300
Closed	00958300000400
Closed	00958300000500
Closed	00958300000600
Closed	00958300000700
Closed	00958300000800
Closed	00958300000900
Closed	00958300001000
Closed	00958300001100
Closed	00956100000400
Closed	00956100000500
Closed	00956100000600
Closed	28060500202300
Closed	28060300100700
Closed	28063200201300
Closed	00952400004700
Closed	31042100304400
Closed	00952500000100
Closed	00952500000200
Closed	00952500000300
Closed	00953900003600
Closed	00953900003700
Closed	00953900003800
Closed	00953900003900
Closed	00953900003400
Closed	00590700000700
Closed	00952400005300
Closed	00952400005400
Closed	00952400005500
Closed	00952400005600
Closed	00952400005700
Closed	00952400005800
Closed	00952400005900
Closed	00952400006000
Closed	00952400006100
Closed	00952400006200
Closed	00952400006300
Closed	00952400006400
Closed	00952400006500
Closed	00952400006600



Accessory Dwelling Units

Index # - File Name: 1.0022 - Single Family Dwellings Data\_Snohomish County.pdf

Closed	00952400006700
Closed	00952400006800
Closed	00952400006900
Closed	00952400007000
Closed	00952400007100
Closed	00952400007200
Closed	00952400004100
Closed	00952400004200
Closed	00952400004300
Closed	00952400004400
Closed	00952400004500
Closed	00952400001900
Closed	00952400002000
Closed	00952400002100
Closed	00952400002200
Closed	00952400002300
Closed	00952400002400
Closed	00952400002500
Closed	00952400002600
Closed	00952400002700
Closed	00952400002800
Closed	00952400002900
Closed	00953900003200
Closed	00953900000500
Closed	00953900000600
Closed	00953900000700
Closed	00953900000800
Closed	00953900000900
Closed	00953900001000
Closed	00953900001100
Closed	00953900001200
Closed	00953900001300
Closed	00953900001400
Closed	00953900001500
Closed	00953900001600
Closed	00953900001700
Closed	00954900001300
Closed	00954900001400
Closed	32091700100800
Closed	32091700100900
Closed	30072800200500
Closed	00952300001800
Closed	30063600301000
Closed	00954900000800
Closed	00954900000500
Closed	00954900000300
Closed	31041100201700

Accessory Dwelling Units

Index # - File Name: 1.0022 - Single Family Dwellings Data\_Snohomish County.pdf

Closed	0095550000600
Closed	00951600001600
Closed	00951600004100
Closed	00951600004200
Closed	00951600004300
Closed	31040300201000
Closed	29051200406400
Closed	00932200000100
Closed	00932200000200
Closed	00933300001100
Closed	00933300001200
Closed	00933300001400
Closed	00933300001500
Closed	00933300001800
Closed	00933300001900
Closed	00933300002000
Closed	00933300001700
Closed	00933300002200
Closed	00931400000600
Closed	31060700300800
Closed	00933300000500
Closed	00933300000400
Closed	00933300003100
Closed	00933300002400
Closed	00933300002500
Closed	00933300002600
Closed	00933300002700
Closed	00933300002800
Closed	00933300003700
Closed	00933300003800
Closed	00933300003900
Closed	00933300004000
Closed	30062400303400
Closed	30062400302900
Closed	31050300200400
Closed	32040300201200
Closed	00936000000300
Closed	00498700000600
Closed	00934500000900
Closed	00934500001200
Closed	00934500000300
Closed	00934500000400
Closed	00934500001100
Closed	00934500002700
Closed	00934500002500
Closed	00934500003600
Closed	00934500002800

Accessory Dwelling Units

Index # - File Name: 1.0022 - Single Family Dwellings Data\_Snohomish County.pdf

Closed	00934500002900
Closed	00934500003000
Closed	00934500003100
Closed	00934500003200
Closed	00934500001500
Closed	00934500001700
Closed	00934500001000
Closed	00934900001000
Closed	00937000001700
Closed	00937000003700
Closed	00937000003900
Closed	00937000004300
Closed	00937000004400
Closed	00937000004500
Closed	00937000004600
Closed	00937000000300
Closed	00937000000600
Closed	00937000000900
Closed	00937000001500
Closed	00937000002600
Closed	00937000002700
Closed	00937000002900
Closed	00937000001100
Closed	00937000003500
Closed	00937100000600
Closed	00389400300104
Closed	00937100001700
Closed	00937000001200
Closed	00937100002400
Closed	29050200303400
Closed	00603100100702
Closed	00937500000700
Closed	00937500000800
Closed	00937500000900
Closed	00937500001000
Closed	00937500000100
Closed	00937500000300
Closed	00937500000400
Closed	00937500001700
Closed	00937500001500
Closed	32043600101500
Closed	00944400004500
Closed	00944400005400
Closed	27063400101000
Closed	29062700402000
Closed	00941700000700
Closed	00937500001900

Accessory Dwelling Units

Index # - File Name: 1.0022 - Single Family Dwellings Data\_Snohomish County.pdf

Closed	00941700001600
Closed	00941700001200
Closed	00941700001300
Closed	00941700001400
Closed	00941700001500
Closed	00948600000100
Closed	00948600000200
Closed	00948600000300
Closed	00942000005700
Closed	00944800000900
Closed	00543800004402
Closed	00951600001100
Closed	27063000305300
Closed	00403800004502
Closed	00952300004100
Closed	00952300004200
Closed	00952300004300
Closed	00952300004400
Closed	00403800012901
Closed	00954400000200
Closed	00952300003600
Closed	00952300001400
Closed	00952300001500
Closed	00952300001600
Closed	00951500012300
Closed	00951500012400
Closed	00951500012500
Closed	00951500012600
Closed	00951500012700
Closed	00951500012800
Closed	00951500012900
Closed	00951500013000
Closed	00951500013200
Closed	00951500013300
Closed	00951500013400
Closed	00951500013500
Closed	00951500013600
Closed	00951500011800
Closed	00951500011900
Closed	00951500003900
Closed	00951500004000
Closed	00951500004100
Closed	00951500004200
Closed	00951500004300
Closed	00951500004400
Closed	00951500004500
Closed	00951500004600

Accessory Dwelling Units

Index # - File Name: 1.0022 - Single Family Dwellings Data\_Snohomish County.pdf

Closed	00951500004700
Closed	00951500004800
Closed	00951500004900
Closed	00951500005000
Closed	00951500005100
Closed	00951500005200
Closed	00951500005300
Closed	00951500005400
Closed	00951500005500
Closed	00951500005600
Closed	00951500005700
Closed	00951500005800
Closed	00951500005900
Closed	00951500006000
Closed	00951500006100
Closed	00951500006200
Closed	00951500006300
Closed	00951500006400
Closed	00951500006500
Closed	00951500006600
Closed	00951500006700
Closed	00951500006800
Closed	00951500006900
Closed	00951500007000
Closed	00951500002800
Closed	00951500002900
Closed	00951500003000
Closed	00951500003100
Closed	00951500003200
Closed	00951500003300
Closed	00951500003400
Closed	00951500003500
Closed	00951500003600
Closed	00951200000500
Closed	00951200000300
Closed	00947600000200
Closed	31042300402000
Closed	30061800402800
Closed	32062100101400
Closed	00943200000100
Closed	00943200000200
Closed	00943200000300
Closed	00943200000400
Closed	00943200000500
Closed	00943200000600
Closed	00943200001100
Closed	00943200001200

Accessory Dwelling Units

Index # - File Name: 1.0022 - Single Family Dwellings Data\_Snohomish County.pdf

Closed	00943200001300
Closed	00943200000900
Closed	00943200002500
Closed	00943200002600
Closed	00943200002300
Closed	00943200002100
Closed	00943200001800
Closed	00943200001400
Closed	00943200001500
Closed	00943200001600
Closed	00944900000700
Closed	00943200002800
Closed	00943200002900
Closed	00943200003200
Closed	00944900000500
Closed	00948600000400
Closed	00948600000500
Closed	00948600000600
Closed	00948600000700
Closed	30063400303500
Closed	30060600101300
Closed	28060800102400
Closed	28060800102500
Closed	00953300003400
Closed	00953300002900
Closed	00953300003000
Closed	00953300001800
Closed	00953300000400
Closed	00947600005000
Closed	00947600004800
Closed	00947600000400
Closed	00947600000500
Closed	00947600004300
Closed	00947600004400
Closed	00947600004500
Closed	00947600004600
Closed	00947600004100
Closed	00947600003400
Closed	00947600003500
Closed	00947600002800
Closed	00947600002900
Closed	00947600003000
Closed	00947600003100
Closed	00947600001900
Closed	00947600002000
Closed	00947600002200
Closed	00947600002300

Accessory Dwelling Units

Index # - File Name: 1.0022 - Single Family Dwellings Data\_Snohomish County.pdf

Closed	00947600002400
Closed	00947600002500
Closed	00953300000200
Closed	00948600002900
Closed	00948600003200
Closed	00948600003300
Closed	00948600001100
Closed	00948600002600
Closed	00947600001600
Closed	00947600000900
Closed	28063200200700
Closed	00958000013500
Closed	00958000013600
Closed	00958000013700
Closed	00958000013800
Closed	00958000013900
Closed	00958000014000
Closed	00958000014100
Closed	27070600104100
Closed	00594000001800
Closed	00594000001900
Closed	01010600000100
Closed	01010600000200
Closed	01010600000400
Closed	01010600000500
Closed	01011100002500
Closed	01011100002600
Closed	01011100002700
Closed	01011100002800
Closed	01011100002900
Closed	01011100003000
Closed	01011100003100
Closed	01011100003200
Closed	01011100003300
Closed	01011100003400
Closed	01011100003500
Closed	01011100003600
Closed	01011100003700
Closed	01011100003800
Closed	01011100003900
Closed	30062800402900
Closed	01011300000200
Closed	01011300000400
Closed	01011300000500
Closed	01011300000800
Closed	01011300001200
Closed	01011300001600

Accessory Dwelling Units

Index # - File Name: 1.0022 - Single Family Dwellings Data\_Snohomish County.pdf

Closed	01011300001700
Closed	01011300002000
Closed	01011300002100
Closed	01011300002500
Closed	01011300002600
Closed	01011300002700
Closed	01011300003200
Closed	01011300003300
Closed	01011300003800
Closed	01011300004100
Closed	01011300004200
Closed	01011300004800
Closed	01011300004900
Closed	01011300005300
Closed	01011300005400
Closed	01011300005900
Closed	01011300006400
Closed	00490300001800
Closed	00625300000501
Closed	27051100104000
Closed	00401000012300
Closed	00401000012500
Closed	01010600000900
Closed	01010600001000
Closed	01010600001100
Closed	01010600001200
Closed	01010600001300
Closed	01010600001500
Closed	01010600001600
Closed	01010600001700
Closed	01011100000300
Closed	01011100000500
Closed	01011100000600
Closed	01011100000700
Closed	01011100001000
Closed	01011100001100
Closed	01011100001200
Closed	01011100001300
Closed	01011100001400
Closed	01011100001500
Closed	01011100001600
Closed	01011100002100
Closed	01011100002200
Closed	01011100002300
Closed	01011100001800
Closed	01010700001000
Closed	01011800001600



Accessory Dwelling Units

Index # - File Name: 1.0022 - Single Family Dwellings Data\_Snohomish County.pdf

Closed	01011800001800
Closed	01011800002000
Closed	01011800002100
Closed	01011800002200
Closed	01011800002300
Closed	01011800003300
Closed	01011800003400
Closed	01011800003600
Closed	01011900000200
Closed	01011900000300
Closed	01011900000400
Closed	01011900000500
Closed	01011900000600
Closed	01011900000900
Closed	01011900001000
Closed	01011900001100
Closed	01011900001200
Closed	01011800003800
Closed	01011800003900
Closed	01011900001400
Closed	01011900001600
Closed	01011900001700
Closed	01011900001800
Closed	01011900001900
Closed	01011900002000
Closed	01011900002100
Closed	01011900002200
Closed	01011900002300
Closed	01011900002500
Closed	01011900002600
Closed	01011900002700
Closed	01011900002800
Closed	01011900002900
Closed	32040300101000
Closed	00493900000600
Closed	32090700200200
Closed	00464200002800
Closed	00484400100110
Closed	00484400100111
Closed	00484400100112
Closed	30051300402300
Closed	01011700000300
Closed	01011700000400
Closed	01011700000500
Closed	01011700000600
Closed	01011700000700
Closed	01011700000800

Accessory Dwelling Units

Index # - File Name: 1.0022 - Single Family Dwellings Data\_Snohomish County.pdf

Closed	0101170000900
Closed	0101170001000
Closed	0101170001100
Closed	0101170001200
Closed	0101170001300
Closed	0101170001400
Closed	0101170001500
Closed	0101170001600
Closed	0101170001700
Closed	0101170001800
Closed	0101170001900
Closed	0101170002000
Closed	0101170002100
Closed	0101170002200
Closed	0101170002300
Closed	0101170002400
Closed	0101170002500
Closed	0101170002600
Closed	0101170002700
Closed	0101170002800
Closed	0101170002900
Closed	0101170003000
Closed	0101170003100
Closed	0101170003200
Closed	0101170004400
Closed	0101170004500
Closed	0101170004600
Closed	0101170004700
Closed	0101170004800
Closed	0101170004900
Closed	0101170005000
Closed	0101170005100
Closed	0101170005200
Closed	0101170005300
Closed	0101170005400
Closed	0101170005500
Closed	0101170005600
Closed	0101170005700
Closed	0101170005800
Closed	0101170005900
Closed	0101170006000
Closed	0101170006100
Closed	0101170006200
Closed	0101170006300
Closed	0101170006400
Closed	0101170006500
Closed	0101170006600

Accessory Dwelling Units

Index # - File Name: 1.0022 - Single Family Dwellings Data\_Snohomish County.pdf

Closed	01011700006700
Closed	01011700006800
Closed	01011700006900
Closed	01011700007000
Closed	01011700007100
Closed	01011700007200
Closed	01011700007300
Closed	01011700007400
Closed	01011700007500
Closed	01011700007600
Closed	01011400001900
Closed	01011400002000
Closed	01011400002100
Closed	01011400002200
Closed	01011400002300
Closed	01011400002400
Closed	01011400002500
Closed	01011400002600
Closed	01011400002700
Closed	01011400004200
Closed	01011400004300
Closed	01011400004400
Closed	01011400004500
Closed	01011400004600
Closed	28070600301100
Closed	01011400004700
Closed	01011400004800
Closed	01011400004900
Closed	01011400005000
Closed	01011400005100
Closed	01011400005200
Closed	01011400005300
Closed	01011400006000
Closed	01011400006100
Closed	01011400006200
Closed	01011400006300
Closed	01011400006400
Closed	01011400006500
Closed	01011400006600
Closed	01011400006700
Closed	01011400006800
Closed	01011400006900
Closed	01011400007000
Closed	01011400007100
Closed	01011400007200
Closed	01011400007300
Closed	01011400007400

Accessory Dwelling Units

Index # - File Name: 1.0022 - Single Family Dwellings Data\_Snohomish County.pdf

Closed	01011400007500
Closed	01011400007600
Closed	01011400007700
Closed	01011400007800
Closed	01011400007900
Closed	01011400008000
Closed	01011400008100
Closed	01011400008200
Closed	01011400008300
Closed	01011400008400
Closed	01011400008500
Closed	01011400008600
Closed	01011400008700
Closed	01011400008800
Closed	01011400008900
Closed	01011400009000
Closed	01011400009100
Closed	28050300303700
Closed	28050300303300
Closed	01011500000100
Closed	01011500000200
Closed	01011400000100
Closed	01011400000200
Closed	01011400001200
Closed	01011400001300
Closed	01011700008400
Closed	00419500001101
Closed	01012100000100
Closed	01012100000300
Closed	01012100000400
Closed	01012100000500
Closed	01012100000600
Closed	01012100000700
Closed	01012100000800
Closed	01012100000900
Closed	01012100001000
Closed	01012100001100
Closed	01012100001200
Closed	01012100001300
Closed	01012100001400
Closed	01012100001500
Closed	01012100001600
Closed	01012100001800
Closed	00622200001301
Closed	00622200001302
Closed	32081200302600
Closed	01012400000100

Accessory Dwelling Units

Index # - File Name: 1.0022 - Single Family Dwellings Data\_Snohomish County.pdf

Closed	0101240000200
Closed	0101240000300
Closed	0101240000400
Closed	0101240000500
Closed	0101240000600
Closed	0101240000700
Closed	0101240000800
Closed	0101240000900
Closed	0101240001000
Closed	0101240001100
Closed	0101240001200
Closed	0101240001300
Closed	0101240001400
Closed	0101240001500
Closed	0101240001600
Closed	0101240001700
Closed	0101150000600
Closed	0101150000700
Closed	0101150000800
Closed	0101150000900
Closed	0101150001000
Closed	0101150001100
Closed	0101150001200
Closed	0101150001300
Closed	0101150001400
Closed	0101150001500
Closed	0101150001700
Closed	0101150001800
Closed	0101250000100
Closed	0101250000200
Closed	0101250000300
Closed	0101250000400
Closed	0101250000600
Closed	0101250001400
Closed	0101250001500
Closed	0101250001600
Closed	0101250001700
Closed	0101250001800
Closed	0101250001900
Closed	0101250002000
Closed	0101250002100
Closed	0101250002200
Closed	0101250001000
Closed	0101250001100
Closed	0101250002400
Closed	0101250002500
Closed	0101250002600

Accessory Dwelling Units

Index # - File Name: 1.0022 - Single Family Dwellings Data\_Snohomish County.pdf

Closed	01013200000100
Closed	01013200000200
Closed	01013200000300
Closed	01013200000400
Closed	01013200000500
Closed	01013200000600
Closed	01013200000700
Closed	01013200000800
Closed	01013200000900
Closed	01013200001000
Closed	01013200001100
Closed	01013100001800
Closed	01013100001900
Closed	01013100002100
Closed	28050300303500
Closed	00494600201505
Closed	00570300203104
Closed	01013100004400
Closed	01013100006100
Closed	01013100006200
Closed	01013100006300
Closed	01013100006400
Closed	01013100006500
Closed	01013100006600
Closed	01013100006700
Closed	01013100006800
Closed	01013100006900
Closed	01013100007000
Closed	01013100007100
Closed	01013100004600
Closed	01013100004700
Closed	01013100004900
Closed	01013100005100
Closed	01013100005600
Closed	01013100008800
Closed	01013100008900
Closed	01013100009000
Closed	01013100009200
Closed	01013100009300
Closed	01013100009400
Closed	01013100009500
Closed	01013100002000
Closed	01013000000100
Closed	01013000000200
Closed	01013000000300
Closed	01013000000400
Closed	01013000000500

Accessory Dwelling Units

Index # - File Name: 1.0022 - Single Family Dwellings Data\_Snohomish County.pdf

Closed	0101300000600
Closed	0101300000700
Closed	0101300000900
Closed	0101300001000
Closed	0101300001100
Closed	0101300001200
Closed	0101300001300
Closed	0101300001400
Closed	0101300001500
Closed	0101300001600
Closed	0101300001700
Closed	0101300001800
Closed	00594900001702
Closed	00594900001703
Closed	01013700000100
Closed	01013700000200
Closed	01013700000300
Closed	01013700000400
Closed	01013700000500
Closed	01013700000600
Closed	01013700000700
Closed	01013700000800
Closed	01013700000900
Closed	01013700001000
Closed	01013700001100
Closed	01013700001200
Closed	01015100000100
Closed	01015100000200
Closed	01015100000300
Closed	01015100000400
Closed	01015100000600
Closed	01015100000700
Closed	01015100000800
Closed	01015100000900
Closed	01015100001000
Closed	01015100001100
Closed	01015100001200
Closed	01014900000100
Closed	01014900000200
Closed	01014900000300
Closed	01014900000400
Closed	01014900000600
Closed	01014900000700
Closed	01017100000100
Closed	01017100000200
Closed	01017100000300
Closed	01017100000400

Accessory Dwelling Units

Index # - File Name: 1.0022 - Single Family Dwellings Data\_Snohomish County.pdf

Closed	01017100000500
Closed	01017100000600
Closed	01017100000700
Closed	01017100001100
Closed	01017100001200
Closed	01017100001300
Closed	01017100001400
Closed	01017100001500
Closed	01017100001600
Closed	01017100001700
Closed	01017100001800
Closed	01017100001900
Closed	01017100002000
Closed	01017100002100
Closed	01017100002200
Closed	01017100002300
Closed	01017100002400
Closed	01017100002500
Closed	01017100002600
Closed	01017100002700
Closed	01017100002800
Closed	01017100002900
Closed	01013000002300
Closed	01013000002400
Closed	01017100003300
Closed	01013100008500
Closed	01017100003800
Closed	01017100004100
Closed	30061400405600
Closed	00625300001300
Closed	27080700201600
Closed	01014500000100
Closed	01014500000200
Closed	01014500000400
Closed	01014500000500
Closed	01014500000900
Closed	01014500001700
Closed	01014500001800
Closed	01014500001900
Closed	01014500002000
Closed	01014500002100
Closed	01014500002200
Closed	01014500002300
Closed	01014500002400
Closed	01014500002500
Closed	01014500001200
Closed	01014500001400



Accessory Dwelling Units

Index # - File Name: 1.0022 - Single Family Dwellings Data\_Snohomish County.pdf

Closed	01014500001500
Closed	01014500003000
Closed	01014700000900
Closed	01014700001000
Closed	01014700001100
Closed	01014700001200
Closed	01014700001300
Closed	01014700001700
Closed	01014500002800
Closed	01014700002200
Closed	01014700002500
Closed	01014700002600
Closed	30051300402400
Closed	28043400302300
Closed	28043400302300
Closed	01014700002900
Closed	00498800101100
Closed	01015000000100
Closed	01015000000200
Closed	01015000000300
Closed	01015000000400
Closed	01015000000500
Closed	01015000000600
Closed	01015000000700
Closed	01015000000800
Closed	01015000000900
Closed	29062600303600
Closed	32051800401600
Closed	28061700201100
Closed	28050100201400
Closed	01015800000400
Closed	01015800000500
Closed	01015800000600
Closed	01015800001000
Closed	01015800001100
Closed	01015800001200
Closed	01015800001300
Closed	01015800001500
Closed	01015800001600
Closed	01015800001700
Closed	01015800001800
Closed	01019800000300
Closed	01019800000500
Closed	01019800000700
Closed	01019800000800
Closed	01019800001100
Closed	01019800001200

Accessory Dwelling Units

Index # - File Name: 1.0022 - Single Family Dwellings Data\_Snohomish County.pdf

Closed	01019800001300
Closed	01019800001400
Closed	01015800002100
Closed	01015800002200
Closed	01019800000100
Closed	01019800001600
Closed	30040100201400
Closed	27052100103200
Closed	01016200000100
Closed	01016200000200
Closed	01016200000300
Closed	01016200000400
Closed	01016200000500
Closed	01016200000600
Closed	01016200000700
Closed	01016200000800
Closed	01016200000900
Closed	01016200001000
Closed	01016200001100
Closed	01016200001200
Closed	01016200001300
Closed	01016200001400
Closed	01016200001500
Closed	01016200001600
Closed	01016200001700
Closed	01016200001800
Closed	01016200001900
Closed	01016200002000
Closed	01016200002100
Closed	01016200002200
Closed	01016200002300
Closed	01016200002400
Closed	01016200002500
Closed	01016200002600
Closed	01016200002700
Closed	01016200002800
Closed	01016200002900
Closed	01016200003000
Closed	01016200003100
Closed	01016200003200
Closed	01016200003300
Closed	01016200003400
Closed	01016200003500
Closed	01016200003600
Closed	01016200003700
Closed	01016200003800
Closed	01015400000100

Accessory Dwelling Units

Index # - File Name: 1.0022 - Single Family Dwellings Data\_Snohomish County.pdf

Closed	01015400000200
Closed	01015400000300
Closed	01015400000500
Closed	01015400000800
Closed	01015500000100
Closed	01015500000300
Closed	01016300000200
Closed	01016300000300
Closed	01016300000400
Closed	01016300000500
Closed	01016300001900
Closed	01016300002000
Closed	01016300002100
Closed	01016300002200
Closed	01016300002300
Closed	01015500001300
Closed	01015500001400
Closed	01015500001500
Closed	01015500001600
Closed	31060500104000
Closed	00579100002203
Closed	31033600100400
Closed	01016900000100
Closed	01016900000200
Closed	01016900000300
Closed	01016900000400
Closed	01016900000500
Closed	01016900000600
Closed	00557300203000
Closed	00494600300506
Closed	01017000001300
Closed	01017000001400
Closed	01016300003500
Closed	01016300003600
Closed	00493400700100
Closed	01017000003400
Closed	01018700001600
Closed	01018700003800
Closed	01017000003200
Closed	00464300000400
Closed	01020100000500
Closed	00512200006100
Closed	00590700000600
Closed	00394403804200
Closed	01020100000200
Closed	01020100000300
Closed	01018800000600

Accessory Dwelling Units

Index # - File Name: 1.0022 - Single Family Dwellings Data\_Snohomish County.pdf

Closed	01018800000700
Closed	01018800000800
Closed	01018800000900
Closed	01018800001000
Closed	01019900003900
Closed	01019900004000
Closed	01019900004100
Closed	01019900004200
Closed	28071000201700
Closed	01018800000400
Closed	01019900003600
Closed	01019900003700
Closed	28053300204400
Closed	28053300204500
Closed	28053300204700
Closed	28053300204900
Closed	28053300205000
Closed	01019700000200
Closed	01019700000300
Closed	01019700000400
Closed	01019700000600
Closed	01019700000700
Closed	01019700000800
Closed	01019700000900
Closed	01019700001000
Closed	01019700001100
Closed	01019200000900
Closed	01019200001000
Closed	01019200001300
Closed	00374800002306
Closed	00374800002307
Closed	00374800002308
Closed	01020200000600
Closed	00374800002301
Closed	00374800002302
Closed	00374800002303
Closed	00374800002304
Closed	01019200001800
Closed	01021700001100
Closed	01020200000200
Closed	01020200000400
Closed	01020200008000
Closed	01020200008100
Closed	01020200008200
Closed	01020200008400
Closed	01020200008500
Closed	01020200008800

Accessory Dwelling Units

Index # - File Name: 1.0022 - Single Family Dwellings Data\_Snohomish County.pdf

Closed	01020200008900
Closed	01020200009000
Closed	01020200009100
Closed	28052600403100
Closed	28052600403200
Closed	28052600403300
Closed	28052600403400
Closed	28052600403500
Closed	01020200007700
Closed	01020200007800
Closed	00608100700101
Closed	30051000302400
Closed	30051000302500
Closed	30051000302600
Closed	30051000302700
Closed	28053600403200
Closed	27063400202400
Closed	00372900600805
Closed	28072000202700
Closed	28072000202900
Closed	28060300101800
Closed	27062900200400
Closed	00490100005500
Closed	28063300203100
Closed	29061400300400
Closed	00557600001602
Closed	30062800302000
Closed	31061800102100
Closed	29070500201400
Closed	30051100201200
Closed	28072900203500
Closed	30060500403500
Closed	27071800401700
Closed	30040200101800
Closed	30062200101400
Closed	31040900201000
Closed	30050200201500
Closed	28072500302500
Closed	00911300001400
Closed	30040800400900
Closed	32040600201400
Closed	32071700400400
Closed	32063500302200
Closed	00401100014200
Closed	00401000014400
Closed	32040500300900
Closed	32063500302000

Accessory Dwelling Units

Index # - File Name: 1.0022 - Single Family Dwellings Data\_Snohomish County.pdf

Closed	30063500101200
Closed	31060600102900
Closed	00895900000300
Closed	00895900000400
Closed	00895200000500
Closed	32061700202400
Closed	00373100700610
Closed	00427100007600
Closed	00373100700607
Closed	30060300103800
Closed	28061200301700
Closed	30060600201500
Closed	32042300401100
Closed	00630600002300
Closed	00630600002300
Closed	00922200000400
Closed	00917600000500
Closed	00917600000800
Closed	00917600000900
Closed	00917600000300
Closed	29051100204200
Closed	29051100204300
Closed	29051100204400
Closed	29051100204500
Closed	00916900003300
Closed	00916900003400
Closed	00916900003100
Closed	00916900002800
Closed	00912600000100
Closed	00912600004100
Closed	00912600003300
Closed	00912400000400
Closed	00912400000600
Closed	00912400000100
Closed	00427100004300
Closed	00594300000803
Closed	00916900001700
Closed	00916900001800
Closed	00916900001900
Closed	00916900002000
Closed	00916900002100
Closed	00916900002200
Closed	00916900000100
Closed	00916900000200
Closed	00466700002000
Closed	32070900201000
Closed	00928500001400

Accessory Dwelling Units

Index # - File Name: 1.0022 - Single Family Dwellings Data\_Snohomish County.pdf

Closed	29061000301200
Closed	00928500000500
Closed	00960007003900
Closed	00928500002000
Closed	00928500000800
Closed	00597600000502
Closed	29063500101500
Closed	29063500101700
Closed	28061400102100
Closed	31052000303000
Closed	32080200403000
Closed	32080200403100
Closed	27051500202400
Closed	29063500304900
Closed	00926500001000
Closed	00923900000800
Closed	00924100001400
Closed	00924100001500
Closed	00924100001800
Closed	00924100001900
Closed	00924100002000
Closed	00924100002100
Closed	00923900000300
Closed	00924100000700
Closed	00924100000800
Closed	00924300000200
Closed	29060300402800
Closed	31050600201000
Closed	31043100300300
Closed	31043100300600
Closed	28082100101900
Closed	29063300302500
Closed	29063200401500
Closed	29063200401700
Closed	29063200402700
Closed	29063200402800
Closed	00919900010101
Closed	00919900010201
Closed	00919900010301
Closed	27080400300400
Closed	00919900009501
Closed	00919900009601
Closed	00401000005000
Closed	00401000015400
Closed	00401000015500
Closed	00543800003904
Closed	00894900002800

Accessory Dwelling Units

Index # - File Name: 1.0022 - Single Family Dwellings Data\_Snohomish County.pdf

Closed	27062800203200
Closed	27062800203300
Closed	27080700301700
Closed	28082100401800
Closed	00889800001800
Closed	32050100401000
Closed	27073200200200
Closed	00885900000500
Closed	32052100305100
Closed	30051300400300
Closed	31062800301800
Closed	29062000103400
Closed	00885500001500
Closed	00885500005800
Closed	00885500005400
Closed	00885500005100
Closed	00885500004400
Closed	00394405803700
Closed	27071800401500
Closed	32040900401300
Closed	28050200305400
Closed	30042600100300
Closed	28060200402400
Closed	27073200200500
Closed	32052100302800
Closed	30062900400200
Closed	29060300101000
Closed	29060300101100
Closed	00385600600800
Closed	28060100100900
Closed	00568700500406
Closed	00457100006000
Closed	29070700300400
Closed	28062400305500
Closed	31042000202000
Closed	00879600000600
Closed	00879600000100
Closed	00500100002703
Closed	29061900200700
Closed	28053600105100
Closed	00403800009702
Closed	29050200303300
Closed	29051100104500
Closed	28060300200700
Closed	00872000000300
Closed	31043000300600
Closed	32052900404000



Accessory Dwelling Units

Index # - File Name: 1.0022 - Single Family Dwellings Data\_Snohomish County.pdf

Closed	30060300101800
Closed	00579100000901
Closed	00372800800104
Closed	00372800800105
Closed	00372800800101
Closed	29073200300500
Closed	00551500011200
Closed	00868400001400
Closed	32063300303900
Closed	32053300401600
Closed	29061400400900
Closed	29063200201500
Closed	27061900401900
Closed	27062000101400
Closed	27051500104900
Closed	27071200400800
Closed	27071300100600
Closed	27090800101500
Closed	27090800101800
Closed	27051000405600
Closed	27071000402600
Closed	27070200102000
Closed	27050300302000
Closed	00373002102701
Closed	00373000400901
Closed	00373000400902
Closed	00373000400903
Closed	00373000400904
Closed	27063500200800
Closed	27063500204600
Closed	27063500204700
Closed	27053300104300
Closed	27062900400600
Closed	27052800106500
Closed	27062700301400
Closed	27062800400700
Closed	27062800202600
Closed	27052500403500
Closed	27052400305900
Closed	27052200102400
Closed	00373701500204
Closed	00373700300403
Closed	00374100500200
Closed	00376900003100
Closed	00414400200100
Closed	00403900021802
Closed	00403900019801

Accessory Dwelling Units

Index # - File Name: 1.0022 - Single Family Dwellings Data\_Snohomish County.pdf

Closed	00403900019903
Closed	00403900024002
Closed	00403800003101
Closed	00403800002602
Closed	00403800006002
Closed	00433100005500
Closed	00433000001400
Closed	00427100007300
Closed	00427100007400
Closed	00427100007500
Closed	00460100005100
Closed	00460200012400
Closed	00631900000600
Closed	00634100002500
Closed	00577700601600
Closed	00563400000700
Closed	00563400000800
Closed	00505100002700
Closed	00509700000400
Closed	00513100004108
Closed	00532100004000
Closed	00526100502400
Closed	28053600300600
Closed	00370600000500
Closed	00373300500400
Closed	00374800002600
Closed	28073500101200
Closed	28043400300300
Closed	28073100402400
Closed	28072500402000
Closed	28072900300900
Closed	28072900302500
Closed	28072900401900
Closed	28052500400800
Closed	28072300101900
Closed	28062200201900
Closed	28072200201000
Closed	28072000201200
Closed	28061500300400
Closed	28061500301800
Closed	28072000400500
Closed	28072000401100
Closed	28060900100600
Closed	28060900103200
Closed	28051100201700
Closed	28051100301800
Closed	28060200401900

Accessory Dwelling Units

Index # - File Name: 1.0022 - Single Family Dwellings Data\_Snohomish County.pdf

Closed	28060200402200
Closed	28060400303600
Closed	28060300101000
Closed	28060500300400
Closed	00741800000900
Closed	00804600000500
Closed	00802400002300
Closed	00430900000601
Closed	00396500003500
Closed	00399200000800
Closed	00405900000800
Closed	00570500101000
Closed	00560000002500
Closed	00568700500804
Closed	00539400002300
Closed	00539800000403
Closed	00573700002100
Closed	00573700004701
Closed	00573700004703
Closed	00574200005700
Closed	00574200007000
Closed	00574200007001
Closed	00608100600302
Closed	00597400000106
Closed	29061400401100
Closed	29061500103600
Closed	29061100401600
Closed	29060400303400
Closed	29070500300500
Closed	29060100201200
Closed	29060100201300
Closed	00622100000100
Closed	00629500000600
Closed	00629500000700
Closed	00629500000800
Closed	00686700000100
Closed	29062600400500
Closed	29062600401200
Closed	29073200101800
Closed	29063400201100
Closed	29062300100600
Closed	29062400301600
Closed	29062100101600
Closed	30062200101600
Closed	30072000101000
Closed	30062000304200
Closed	30041700400900

Accessory Dwelling Units

Index # - File Name: 1.0022 - Single Family Dwellings Data\_Snohomish County.pdf

Closed	30061400405000
Closed	30060700203400
Closed	30060700202000
Closed	30050900103800
Closed	30051100200800
Closed	30051300202200
Closed	30060200303400
Closed	29053600402100
Closed	00470900001300
Closed	00470900001900
Closed	00492000108500
Closed	00493000000400
Closed	00492100001600
Closed	00491600003600
Closed	00590700028500
Closed	00590700023101
Closed	00548200001400
Closed	00581600000706
Closed	00533400004600
Closed	30060100300400
Closed	30040200101400
Closed	00625300002600
Closed	00625300002900
Closed	00611300021002
Closed	00614100301000
Closed	00736500000900
Closed	00631600007500
Closed	00622400001600
Closed	00624200200200
Closed	00627300005700
Closed	00579800000804
Closed	00557300202900
Closed	00557300203100
Closed	00556800201102
Closed	00531400200200
Closed	00543300002100
Closed	00520200003100
Closed	00520200004000
Closed	00543800001000
Closed	00429100000100
Closed	00401000010700
Closed	30043500100700
Closed	30063400200100
Closed	31051700302200
Closed	31051600100200
Closed	31051800201200
Closed	31061700303000

Accessory Dwelling Units

Index # - File Name: 1.0022 - Single Family Dwellings Data\_Snohomish County.pdf

Closed	31061800300500
Closed	31042200202600
Closed	31042200304000
Closed	31042300401800
Closed	31060800401200
Closed	31040800301200
Closed	31041300102400
Closed	31041300400900
Closed	31051300100600
Closed	31050400300100
Closed	31040400101600
Closed	31040500201500
Closed	31063100101500
Closed	31063200101400
Closed	31062800300200
Closed	31063000200100
Closed	31052600400500
Closed	31063300301300
Closed	31043500201900
Closed	31053500401600
Closed	00394401009000
Closed	00394511100303
Closed	00394406200802
Closed	00394405101400
Closed	32062900300900
Closed	32052800301700
Closed	32053200400200
Closed	32053200403100
Closed	32073000400100
Closed	32042300300900
Closed	32092300301000
Closed	32042400100900
Closed	32042700300600
Closed	32041800303200
Closed	32051800101200
Closed	32051800101900
Closed	32051500401000
Closed	32041000300100
Closed	32041100100200
Closed	32041100100200
Closed	32041200300800
Closed	32041200301100
Closed	32041200301200
Closed	32041200100200
Closed	32041200301300
Closed	32100800201400
Closed	32040800202200

Accessory Dwelling Units

Index # - File Name: 1.0022 - Single Family Dwellings Data\_Snohomish County.pdf

Closed	32090600400300
Closed	32090700201200
Closed	32090700301400
Closed	32090500400100
Closed	00717400000600
Closed	00630700000100
Closed	32080200301100
Closed	32060300301200
Closed	32040400300100
Closed	32050400201200
Closed	00499100104200
Closed	00546900003200
Closed	00585200005800
Closed	00490900003600
Closed	00491000000800
Closed	00494511501300
Closed	30061000401300
Closed	00598100005600
Closed	30062500201600
Closed	30070100301100
Closed	27063000203900
Closed	28083000100700
Closed	31050100102600
Closed	31062700401300
Closed	00589600004600
Closed	00589600006600
Closed	00529100000300
Closed	00587000003200
Closed	00587200002600
Closed	00490200000500
Closed	00383800002000
Closed	32063400400900
Closed	32063400302400
Closed	32043600101100
Closed	00383800000400
Closed	29061100401000
Closed	32040700401700
Closed	27073100201500
Closed	28073600101600
Closed	31042000400100
Closed	29062100200700
Closed	31062900101000
Closed	00597400002400
Closed	00818500000100
Closed	00818500000200
Closed	00818500000400
Closed	00818500001000

Accessory Dwelling Units

Index # - File Name: 1.0022 - Single Family Dwellings Data\_Snohomish County.pdf

Closed	00597400001503
Closed	00824300000300
Closed	00824500000400
Closed	00587200004200
Closed	00466900001600
Closed	32051600100500
Closed	28050200101500
Closed	31062900400800
Closed	32060400400700
Closed	27052100202400
Closed	00384500005100
Closed	00394507100400
Closed	28060200200200
Closed	00394401500011
Closed	31062900301800
Closed	30060500402700
Closed	29060200200900
Closed	30052000300500
Closed	00860500001700
Closed	31063200400500
Closed	00600700001300
Closed	29060600200400
Closed	00403900016601
Closed	00473300700503
Closed	27062500100500
Closed	30060500402100
Closed	30060500401200
Closed	29061500400700
Closed	31040300401200
Closed	30060500401800
Closed	30060500401900
Closed	30060800200600
Closed	30060800200700
Closed	30060800200800
Closed	00394403402600
Closed	28081900300900
Closed	28073500202000
Closed	29070500401100
Closed	30063500200200
Closed	00587400000502
Closed	28061400401600
Closed	28070600300200
Closed	00630600000800
Closed	30062900303400
Closed	27063300300900
Closed	31062900300600
Closed	30061900103100

Accessory Dwelling Units

Index # - File Name: 1.0022 - Single Family Dwellings Data\_Snohomish County.pdf

Closed	32060800400200
Closed	00489100003100
Closed	27072900201100
Closed	30062900302000
Closed	30050600301900
Closed	27081100100400
Closed	30061700201100
Closed	00551400004500
Closed	31060600301700
Closed	32042500301900
Closed	00403800015307
Closed	30041500401800
Closed	30060500402200
Closed	27073000400200
Closed	00473300700503
Closed	00862500000600
Closed	00473300003404
Closed	00401000012200
Closed	30063200300400
Closed	32042700200300
Closed	31060900200900
Closed	00579100000103
Closed	28080900400200
Closed	30061100200400
Closed	30060500403000
Closed	32042600201200
Closed	30060200102500
Closed	00864000000100
Closed	00864000000200
Closed	00864000000300
Closed	00864000000400
Closed	00864000000500
Closed	00864000000600
Closed	31061800102000
Closed	27071100200900
Closed	00585900002000
Closed	29062000209500
Closed	00401100013600
Closed	32042100401200
Closed	27071100400200
Closed	00819000001000
Closed	00520200004900
Closed	29053600101300
Closed	27062700401900
Closed	27071800103800
Closed	27062800403600
Closed	27062800403700



Accessory Dwelling Units

Index # - File Name: 1.0022 - Single Family Dwellings Data\_Snohomish County.pdf

Closed	27062800403800
Closed	00808500000300
Closed	28061200401500
Closed	32050800300300
Closed	00413900000100
Closed	00490100006100
Closed	00589600005400
Closed	00589600011100
Closed	00442900201703
Closed	32071900100400
Closed	00841800003300
Closed	28061100301700
Closed	30060800103100
Closed	30060800101900
Closed	00376800004100
Closed	00840300000500
Closed	28073000100200
Closed	00370500000602
Closed	30062400301900
Closed	30041700400300
Closed	30051200101200
Closed	28072000200900
Closed	00490800101700
Closed	00483000002600
Closed	00499100201200
Closed	32050400201800
Closed	32050400202000
Closed	32040400301300
Closed	32050400201000
Closed	32040400103100
Closed	32060300301600
Closed	32040300401300
Closed	32040300402000
Closed	00630700000300
Closed	00630700000400
Closed	32090600300600
Closed	32090700302400
Closed	32070800100100
Closed	32041200301400
Closed	32091100401400
Closed	32051200301100
Closed	32081200101300
Closed	32051300300400
Closed	32041300401600
Closed	32051500401400
Closed	32051600400900
Closed	32042100401000

Accessory Dwelling Units

Index # - File Name: 1.0022 - Single Family Dwellings Data\_Snohomish County.pdf

Closed	32062000400900
Closed	32072000200219
Closed	32052600401300
Closed	32042600201700
Closed	32052700100500
Closed	32042400200800
Closed	32042300301100
Closed	32042200100800
Closed	32052200100200
Closed	32052200101600
Closed	32063200102400
Closed	32042900101300
Closed	32052900401700
Closed	00394403200500
Closed	00394402300901
Closed	00394402301001
Closed	00394402301002
Closed	00394405004100
Closed	00394405004100
Closed	00394406301600
Closed	00394406601300
Closed	00394510901300
Closed	00483000000800
Closed	00381900000600
Closed	31053500402800
Closed	31063500202900
Closed	31043400401800
Closed	31052600401100
Closed	31052600401200
Closed	31062900100400
Closed	31052600303600
Closed	31063200201400
Closed	31063100100500
Closed	31040500301200
Closed	31040500301800
Closed	31060400400300
Closed	31060400400500
Closed	31060400203000
Closed	31060500101900
Closed	31040400201400
Closed	31041000300400
Closed	31060900301900
Closed	31041000102400
Closed	31040900201200
Closed	31040800302200
Closed	31040800201200
Closed	31042300402800

Accessory Dwelling Units

Index # - File Name: 1.0022 - Single Family Dwellings Data\_Snohomish County.pdf

Closed	31052400400300
Closed	31042600302400
Closed	31052400202300
Closed	31051800101000
Closed	31051800101800
Closed	31051800402700
Closed	31041400201400
Closed	31041400201800
Closed	31051700305200
Closed	31051700305100
Closed	31051700304000
Closed	30073000100900
Closed	30062900301800
Closed	30043600200800
Closed	00401000010800
Closed	00401000006200
Closed	00420900000500
Closed	00423700001400
Closed	00470600008300
Closed	00480000010300
Closed	00550700002600
Closed	00520200005000
Closed	00511000009000
Closed	28051100404500
Closed	28081900201500
Closed	00556800200300
Closed	00557300202600
Closed	00551500001500
Closed	00551500001100
Closed	00551500001200
Closed	00549800000100
Closed	00582600101200
Closed	00590700002300
Closed	00622400000800
Closed	00631600001700
Closed	00628400002000
Closed	00792700000200
Closed	00611300012401
Closed	00630800002600
Closed	30040200402000
Closed	00632600001000
Closed	00625900000301
Closed	00548200000500
Closed	00543500000500
Closed	00591200200104
Closed	00604900001006
Closed	00604800001001

Accessory Dwelling Units

Index # - File Name: 1.0022 - Single Family Dwellings Data\_Snohomish County.pdf

Closed	00597300000901
Closed	00597500001000
Closed	00493700002802
Closed	00505500200700
Closed	00516700005300
Closed	00516700005400
Closed	00516700005800
Closed	00492000106800
Closed	00491900200900
Closed	00491600003100
Closed	00491600002100
Closed	00471400006000
Closed	00460400000305
Closed	00467100002700
Closed	00457100002705
Closed	00442100002500
Closed	00442100000300
Closed	00417700000600
Closed	00431400600804
Closed	30060200302600
Closed	30060200400800
Closed	30050200101000
Closed	30040200402600
Closed	30040600101100
Closed	30050600201800
Closed	30040400101000
Closed	30040600200300
Closed	30061200401900
Closed	30070700302200
Closed	30080800302600
Closed	30061900402300
Closed	30062200300400
Closed	30042300202500
Closed	29062000400700
Closed	29061600302700
Closed	29062100101500
Closed	29062200402900
Closed	29063300102400
Closed	00636000001000
Closed	00616900000100
Closed	29060100202000
Closed	00712500000200
Closed	29060300301400
Closed	29061500103900
Closed	00597400001104
Closed	00575000000800
Closed	00574200009200

Accessory Dwelling Units

Index # - File Name: 1.0022 - Single Family Dwellings Data\_Snohomish County.pdf

Closed	00608500300302
Closed	00607000000100
Closed	00614700601000
Closed	00574200005000
Closed	00574100011901
Closed	00570300100100
Closed	00431900006100
Closed	00432100001900
Closed	00432600006400
Closed	00802400003200
Closed	00758800000900
Closed	00711600003200
Closed	28060400400200
Closed	28060300200900
Closed	28060200301900
Closed	28050100202000
Closed	28070900401600
Closed	28071000200500
Closed	28060900202200
Closed	28061100300700
Closed	28071200100500
Closed	28072000100300
Closed	28071700300500
Closed	28061800105300
Closed	28061500101000
Closed	28061500103200
Closed	28082100101800
Closed	28072200201400
Closed	28072300200200
Closed	28072500100200
Closed	28062500201500
Closed	28062500300100
Closed	28072900201400
Closed	28072600201000
Closed	28072600202200
Closed	28072800303600
Closed	28083100200800
Closed	28063200303000
Closed	28063200403400
Closed	28073200103200
Closed	28073300404400
Closed	00375000003802
Closed	00375000003803
Closed	00370500000801
Closed	00525600003700
Closed	00525600004200
Closed	00512200005500

Accessory Dwelling Units

Index # - File Name: 1.0022 - Single Family Dwellings Data\_Snohomish County.pdf

Closed	00512100002800
Closed	00512000214000
Closed	00509700000500
Closed	00509700001000
Closed	00509700001100
Closed	00510300004200
Closed	00464100001400
Closed	00500100002600
Closed	00577200002700
Closed	00655100000200
Closed	00624600000200
Closed	00623700001600
Closed	00460200015900
Closed	00460200016000
Closed	00460200016500
Closed	00460200018800
Closed	00460200019100
Closed	00460200011900
Closed	00427200001600
Closed	00403800006801
Closed	00403800002800
Closed	00403800003200
Closed	00414400200500
Closed	00403900025902
Closed	00403900022902
Closed	00379600000300
Closed	00389400200401
Closed	00389400300502
Closed	00403800000804
Closed	00373701600306
Closed	00373003100301
Closed	00373003100306
Closed	00373003100307
Closed	27062200201500
Closed	27052400205100
Closed	27052300202400
Closed	27052800305400
Closed	27062900200100
Closed	27063000203400
Closed	27073100200600
Closed	27043100208100
Closed	27063500301300
Closed	27103400401300
Closed	00373000300106
Closed	00373000800204
Closed	00373001900500
Closed	27053600300900

Accessory Dwelling Units

Index # - File Name: 1.0022 - Single Family Dwellings Data\_Snohomish County.pdf

Closed	27053600301000
Closed	27060300400600
Closed	27070100200700
Closed	27090400100700
Closed	27051100400400
Closed	27090800202200
Closed	27051200202800
Closed	27061600302600
Closed	27051800201700
Closed	27071900103000
Closed	27052100207800
Closed	27062800401900
Closed	27071800202500
Closed	27071800401200
Closed	32041500200200
Closed	00401100011600
Closed	28072800201300
Closed	00394507600200
Closed	00401100012900
Closed	32043600401600
Closed	32081200401900
Closed	31043100402300
Closed	28071000400900
Closed	27052200203200
Closed	31060400203100
Closed	00466200001700
Closed	00464600001300
Closed	00879600000400
Closed	31042300402600
Closed	28062900402300
Closed	00585700007800
Closed	32061700300300
Closed	30050500200100
Closed	30072900400300
Closed	29060300100800
Closed	00401100007100
Closed	32050600300400
Closed	00494600300603
Closed	31042700103400
Closed	32051400400900
Closed	31043200300400
Closed	31063300400700
Closed	00403800012702
Closed	32053300202700
Closed	32053300203400
Closed	32053300203500
Closed	00617300201103

Accessory Dwelling Units

Index # - File Name: 1.0022 - Single Family Dwellings Data\_Snohomish County.pdf

Closed	32063600201500
Closed	30042600100300
Closed	28070800400400
Closed	00467100010500
Closed	30061900303200
Closed	29063400101200
Closed	00419500001302
Closed	30060100301400
Closed	00885800000100
Closed	31063100301400
Closed	28062800302100
Closed	32051300201600
Closed	29063500102100
Closed	32063200304700
Closed	32063200304900
Closed	29063300302600
Closed	29051100400800
Closed	30051200301500
Closed	28072100302600
Closed	31043100300400
Closed	00926600000900
Closed	00926600001400
Closed	00924100000900
Closed	00924100001000
Closed	00924100001100
Closed	00924100001200
Closed	00924100001300
Closed	00924100001600
Closed	00924100001700
Closed	00394510301300
Closed	27063400202700
Closed	30072900402200
Closed	27052300200600
Closed	30060800401300
Closed	28052500303300
Closed	00928500001000
Closed	00928500001100
Closed	00928500001700
Closed	00928500001800
Closed	00928500001900
Closed	00928500000200
Closed	00928500000300
Closed	00928500001500
Closed	00556800101201
Closed	00928500000100
Closed	29062300400700
Closed	00912600004300



Accessory Dwelling Units

Index # - File Name: 1.0022 - Single Family Dwellings Data\_Snohomish County.pdf

Closed	00913400001400
Closed	00617300100100
Closed	00922200000100
Closed	00922200000200
Closed	32053300104300
Closed	00895200000100
Closed	00401100012500
Closed	00401100012800
Closed	29062000405100
Closed	32041000301300
Closed	30060500101200
Closed	30060500101100
Closed	00401000015600
Closed	28062400401800
Closed	00401100008200
Closed	00401000011900
Closed	32040600201500
Closed	00394401903600
Closed	00394510800200
Closed	00901200000500
Closed	32051400100700
Closed	00900900000200
Closed	00900900000300
Closed	00900900000600
Closed	32090800400100
Closed	30040800400900
Closed	00911300000600
Closed	28072500302600
Closed	30063500300500
Closed	28043300300700
Closed	29070500201600
Closed	27063400103100
Closed	29070500201300
Closed	30060800103400
Closed	00625600000300
Closed	01021600000100
Closed	01021600000200
Closed	01021600000300
Closed	01021600000400
Closed	01021600000500
Closed	01021600000600
Closed	01021600000700
Closed	01021600000800
Closed	01021600000900
Closed	01021600001000
Closed	01021600001100
Closed	01021600001200

Accessory Dwelling Units

Index # - File Name: 1.0022 - Single Family Dwellings Data\_Snohomish County.pdf

Closed	01021600001400
Closed	01021600001500
Closed	01021600001600
Closed	01021600001700
Closed	01021600001800
Closed	01021600001900
Closed	01021600002000
Closed	01021600002100
Closed	01021600002200
Closed	01021600002300
Closed	01021600002400
Closed	01021600002500
Closed	01021600002600
Closed	01021600002700
Closed	30063000301100
Closed	01022900000200
Closed	01022900000400
Closed	01022900000500
Closed	01022900000600
Closed	01022900000700
Closed	01022900000800
Closed	01022900000900
Closed	01022900001100
Closed	01022900001200
Closed	01022900001300
Closed	01022900001400
Closed	29062300301100
Closed	01021300000200
Closed	32041400300800
Closed	30062500100600
Closed	01020300000600
Closed	01042800002100
Closed	01042800002200
Closed	01042800002300
Closed	30060600301300
Closed	01020300000400
Closed	31041800200400
Closed	32063600203100
Closed	01023800000100
Closed	00556600011800
Closed	00548000302301
Closed	01023800000200
Closed	01023800001000
Closed	01023800001100
Closed	01023800001200
Closed	01023800001300
Closed	01023800001400

Accessory Dwelling Units

Index # - File Name: 1.0022 - Single Family Dwellings Data\_Snohomish County.pdf

Closed	01023800001500
Closed	01023800001600
Closed	01023800001700
Closed	01023800001800
Closed	01023800001900
Closed	01023800000500
Closed	01023800000600
Closed	01023800000700
Closed	01023800002100
Closed	01023700000200
Closed	01023700000300
Closed	01023700000400
Closed	01023700000500
Closed	01023700000600
Closed	01023700000700
Closed	01023700000800
Closed	01023700000900
Closed	01023700001000
Closed	01023700001100
Closed	01023700001200
Closed	01023700001300
Closed	27051800104900
Closed	01021900000100
Closed	01021900000200
Closed	01021900000300
Closed	01021900000400
Closed	01021900000500
Closed	01021900000600
Closed	01021900000700
Closed	01021900000800
Closed	01021900000900
Closed	01021900001000
Closed	01021900001100
Closed	01021900001200
Closed	01021900001300
Closed	01021900001400
Closed	01021900001500
Closed	01021900001600
Closed	01021900001700
Closed	01021900001800
Closed	01021900001900
Closed	01021900002000
Closed	01021900002100
Closed	01021900002200
Closed	01021900002300
Closed	01021900002400
Closed	01021900002500

Accessory Dwelling Units

Index # - File Name: 1.0022 - Single Family Dwellings Data\_Snohomish County.pdf

Closed	01021900002600
Closed	01021900002700
Closed	01021900002800
Closed	01021900002900
Closed	01021900003000
Closed	01021900003100
Closed	01021900003200
Closed	01021900003300
Closed	01021900003400
Closed	01021900003500
Closed	01021900003600
Closed	01021900003700
Closed	01021900003800
Closed	01021900003900
Closed	01021900004000
Closed	01021900004100
Closed	01021900004200
Closed	01021900004300
Closed	01021900004400
Closed	01021900004500
Closed	01021900004600
Closed	01021900004700
Closed	01021900004800
Closed	01021900004900
Closed	01021900005000
Closed	01021900005100
Closed	01021900005200
Closed	01021900005300
Closed	01021900005400
Closed	01021900005500
Closed	01021900005600
Closed	01020500000100
Closed	01020500000200
Closed	01020500000300
Closed	01020500000400
Closed	01020500000500
Closed	01020500000600
Closed	01020500000700
Closed	01020500000800
Closed	01020500000900
Closed	01020500001000
Closed	01020500001100
Closed	01020600000100
Closed	01020600000200
Closed	01020600000300
Closed	01020600000400
Closed	01020600000500

Accessory Dwelling Units

Index # - File Name: 1.0022 - Single Family Dwellings Data\_Snohomish County.pdf

Closed	01020600000600
Closed	01020600000700
Closed	01020600000800
Closed	01020600000900
Closed	01020300000100
Closed	01020300001100
Closed	01020300001200
Closed	01020300001300
Closed	01020300001400
Closed	01042800000100
Closed	01042800000200
Closed	01042800000300
Closed	01042800000400
Closed	01042800000500
Closed	01042800000600
Closed	01042800000700
Closed	01042800000800
Closed	01042800000900
Closed	01042800001000
Closed	01042800001100
Closed	01042800001200
Closed	01042800001300
Closed	01042800001400
Closed	01042800001500
Closed	00480401803502
Closed	01020200007900
Closed	01020200009200
Closed	01020200009300
Closed	01020200008600
Closed	01020200008700
Closed	01020200008300
Closed	01020200000500
Closed	01020200000300
Closed	00403900021101
Closed	01020200000100
Closed	30073200202400
Closed	00374800002305
Closed	01020200000800
Closed	01020200000900
Closed	01020200001000
Closed	01020200001100
Closed	01020200001200
Closed	01020200001300
Closed	01020200001400
Closed	01020200001500
Closed	01020200001600
Closed	01020200001700

Accessory Dwelling Units

Index # - File Name: 1.0022 - Single Family Dwellings Data\_Snohomish County.pdf

Closed	01020200001800
Closed	01020200001900
Closed	01020200002000
Closed	01020200002100
Closed	01020200002200
Closed	01020200002300
Closed	01020200002400
Closed	01020200002500
Closed	01020200002600
Closed	01020200002800
Closed	01020200002900
Closed	01020200003000
Closed	01020200003100
Closed	01020200003200
Closed	01020200003300
Closed	01020200003500
Closed	01020200003600
Closed	01020200003700
Closed	01020200003800
Closed	01020200003900
Closed	01020200004000
Closed	01020200004100
Closed	01020200004200
Closed	01020200004300
Closed	01020200004400
Closed	01020200004500
Closed	01020200004600
Closed	01020200004700
Closed	01020200004800
Closed	01020200004900
Closed	01020200005000
Closed	01020200005100
Closed	01020200005200
Closed	01020200005300
Closed	01020200005400
Closed	01020200005500
Closed	01020200005600
Closed	01020200005700
Closed	01020200005800
Closed	01020200005900
Closed	01020200006000
Closed	01020200006100
Closed	01020200006200
Closed	01020200006300
Closed	01020200006400
Closed	01020200006500
Closed	01020200006600

Accessory Dwelling Units

Index # - File Name: 1.0022 - Single Family Dwellings Data\_Snohomish County.pdf

Closed	01020200006700
Closed	01020200006800
Closed	01020200006900
Closed	01020200007000
Closed	01020200007100
Closed	01020200007200
Closed	01020200007300
Closed	01020200007400
Closed	01020200007500
Closed	01020200007600
Closed	31062100200900
Closed	01021100000100
Closed	01021100000200
Closed	01021100000300
Closed	01021100000400
Closed	01021100000500
Closed	01021100000600
Closed	01021100000700
Closed	01021100000800
Closed	01021700000100
Closed	01021700000200
Closed	01021700000300
Closed	01021700000400
Closed	01021700000500
Closed	01021700000600
Closed	01021700000700
Closed	01021700000800
Closed	01021700001000
Closed	01019200001400
Closed	01019200001500
Closed	01019200001600
Closed	01019200001700
Closed	01019200001100
Closed	01019200001200
Closed	00373700401103
Closed	01019200000100
Closed	01019200000200
Closed	01019200000300
Closed	01019200000400
Closed	01019200000500
Closed	01019200000600
Closed	01019200000700
Closed	01019200000800
Closed	01019100014200
Closed	01019100014300
Closed	01019100014400
Closed	01019100014500

Accessory Dwelling Units

Index # - File Name: 1.0022 - Single Family Dwellings Data\_Snohomish County.pdf

Closed	01019100014600
Closed	01019100014700
Closed	01019100014800
Closed	01019100014900
Closed	01019100015000
Closed	01019100015100
Closed	00394402100100
Closed	01019100005000
Closed	01019100005100
Closed	01019100005200
Closed	01019100005300
Closed	01019100005400
Closed	01019100005500
Closed	01019100005600
Closed	01019100005700
Closed	01019100005800
Closed	01019100005900
Closed	01019100006000
Closed	01019100006100
Closed	01019100006200
Closed	01019100006300
Closed	01019100006400
Closed	01019100006500
Closed	01019100006600
Closed	01019100006700
Closed	01019100006800
Closed	01019100006900
Closed	01019100007000
Closed	01019100007100
Closed	01019100007200
Closed	01019100004800
Closed	01019100007400
Closed	01019100007500
Closed	01019100007600
Closed	01019100008000
Closed	01019100008100
Closed	01019100008200
Closed	01019100008300
Closed	01019100008400
Closed	01019100008500
Closed	01019100008600
Closed	01019100008700
Closed	01019100009700
Closed	01019100009800
Closed	01019100009900
Closed	01019100010000
Closed	01019100010100



Accessory Dwelling Units

Index # - File Name: 1.0022 - Single Family Dwellings Data\_Snohomish County.pdf

Closed	01019100010200
Closed	01019100010300
Closed	01019100010400
Closed	01019100009000
Closed	01019100009100
Closed	01019100009200
Closed	01019100007800
Closed	00385600500700
Closed	01019400000100
Closed	01019400000200
Closed	01019400000300
Closed	01019400000400
Closed	01019400000500
Closed	01019400000600
Closed	01019400000700
Closed	01019400000800
Closed	01019400000900
Closed	01019400001000
Closed	01019400001100
Closed	01019400001200
Closed	01019900003800
Closed	01018800000500
Closed	00538000001702
Closed	00538000001703
Closed	00431900001700
Closed	00579800000405
Closed	00579800000408
Closed	01020700000100
Closed	01020700000200
Closed	01020700000300
Closed	01020700000400
Closed	01020700000500
Closed	01020700000600
Closed	01020700000700
Closed	01020700000800
Closed	01019500004300
Closed	01019500004400
Closed	01019500004500
Closed	01019500004600
Closed	01019500004700
Closed	01019500004800
Closed	01019500004900
Closed	01019500005000
Closed	01019500005100
Closed	01019500005200
Closed	01019500005300
Closed	01019500005400

Accessory Dwelling Units

Index # - File Name: 1.0022 - Single Family Dwellings Data\_Snohomish County.pdf

Closed	01019500005500
Closed	01019500005600
Closed	01019500005700
Closed	01019500005800
Closed	01019500005900
Closed	01019500006000
Closed	01019500006100
Closed	01019500006200
Closed	01019500006300
Closed	01019500006500
Closed	01019500006700
Closed	01019500006800
Closed	01019500006900
Closed	01019500007000
Closed	01019500007100
Closed	01019500007200
Closed	01019500007300
Closed	01019500007400
Closed	01019400002800
Closed	01019400002900
Closed	01019400003000
Closed	01019400003100
Closed	01019400003200
Closed	01019400003300
Closed	01019400003500
Closed	01019400003600
Closed	01019400003700
Closed	01019400003800
Closed	01019400003900
Closed	01019400006300
Closed	01019400006400
Closed	01019400006500
Closed	01019400006600
Closed	01019400006700
Closed	01019400006800
Closed	27102100100500
Closed	00548000200300
Closed	00548000200202
Closed	01019100002700
Closed	01019100002800
Closed	01019100002900
Closed	01019100003000
Closed	01019100003100
Closed	01024100000100
Closed	01024100000200
Closed	01024100000300
Closed	01024100000400

Accessory Dwelling Units

Index # - File Name: 1.0022 - Single Family Dwellings Data\_Snohomish County.pdf

Closed	01024100000500
Closed	01024100000600
Closed	01024100000700
Closed	01024100000800
Closed	01024100000900
Closed	01024100001000
Closed	01024100001100
Closed	01024100001200
Closed	01024100001300
Closed	01024100001400
Closed	01024100001500
Closed	01024100001600
Closed	01024100001700
Closed	01024100001800
Closed	01024100001900
Closed	01024100002000
Closed	01024100002100
Closed	01024100002200
Closed	01024100002300
Closed	01024100002400
Closed	01024100002500
Closed	01024100002600
Closed	01024100002700
Closed	01024100002800
Closed	01024100002900
Closed	01024100003000
Closed	01024100003100
Closed	01024100003200
Closed	01024100003300
Closed	01024100003400
Closed	27051000300800
Closed	00373001401105
Closed	00394406500600
Closed	29053600100900
Closed	01023500000100
Closed	01023500000200
Closed	01023500000300
Closed	01023500000400
Closed	01023500000500
Closed	01023500000600
Closed	01023500000700
Closed	01023500000900
Closed	01023500001000
Closed	01023500001100
Closed	01023500001200
Closed	01023500001300
Closed	01023500001400

Accessory Dwelling Units

Index # - File Name: 1.0022 - Single Family Dwellings Data\_Snohomish County.pdf

Closed	01023500001500
Closed	01023500001600
Closed	01023500001700
Closed	01023500001800
Closed	01023800002700
Closed	01023800002800
Closed	01023800003500
Closed	01023800003700
Closed	01023800003800
Closed	01023800003900
Closed	01023800004000
Closed	01023800004100
Closed	01023800004200
Closed	01023800004400
Closed	01023700000100
Closed	01023400101600
Closed	01022500000100
Closed	01022500000200
Closed	01022500000300
Closed	01022500000400
Closed	01022500000500
Closed	01022500000600
Closed	01022500000700
Closed	01022500000800
Closed	01022500000900
Closed	01022500001000
Closed	01022500001100
Closed	01022500001200
Closed	01022500001300
Closed	00604900001206
Closed	01023600000100
Closed	01023600000200
Closed	01023600000300
Closed	01023600000400
Closed	01023600000500
Closed	01023600000600
Closed	01023600000700
Closed	01023600000800
Closed	01023600000900
Closed	00372801001405
Closed	27051900106500
Closed	00373300500608
Closed	00373300500609
Closed	00373300500610
Closed	01026900100100
Closed	01026900100200
Closed	01026900100300

Accessory Dwelling Units

Index # - File Name: 1.0022 - Single Family Dwellings Data\_Snohomish County.pdf

Closed	01026900100400
Closed	01026900100500
Closed	01026900100600
Closed	01026900100700
Closed	01026900100800
Closed	01026900100900
Closed	01026900101000
Closed	01026900101100
Closed	01026900101200
Closed	01026900101300
Closed	01026900101400
Closed	01026900101500
Closed	01026900101600
Closed	01026900101700
Closed	01026900101800
Closed	01026900101900
Closed	01026900102000
Closed	01026900102100
Closed	01026900103400
Closed	01026900103500
Closed	01026900103600
Closed	01026900103700
Closed	01026900103800
Closed	01026900103900
Closed	01026900104000
Closed	01026900104100
Closed	01026900104200
Closed	01026900104300
Closed	01026900104400
Closed	01026900104500
Closed	01026900104600
Closed	01026900104700
Closed	01026900104800
Closed	01026900104900
Closed	01026900105000
Closed	01026900105100
Closed	01026900105200
Closed	01026900105300
Closed	01026900105400
Closed	01026900105500
Closed	01026900105600
Closed	01026900105700
Closed	01026900105800
Closed	01026900105900
Closed	01026900106000
Closed	01026900106500
Closed	01026900106600

Accessory Dwelling Units

Index # - File Name: 1.0022 - Single Family Dwellings Data\_Snohomish County.pdf

Closed	01026900106700
Closed	01026900106800
Closed	01026900106900
Closed	01026900107000
Closed	01026900107100
Closed	01026900107200
Closed	01026900107300
Closed	01026900107400
Closed	01026900107500
Closed	01026900107600
Closed	01026900107700
Closed	01026900107800
Closed	01026900107900
Closed	01026900108000
Closed	01026900108100
Closed	01026900108200
Closed	01026900108300
Closed	01026900108400
Closed	01026900108500
Closed	01026900108600
Closed	01026900108700
Closed	31050100202100
Closed	01030700006200
Closed	27071100101100
Closed	01025100000100
Closed	01025100000200
Closed	01025100000300
Closed	01025100000400
Closed	01025100000500
Closed	01025100000600
Closed	01025100000700
Closed	01025100000800
Closed	01025100000900
Closed	01025100001000
Closed	01025100001100
Closed	01025100001200
Closed	01025100001300
Closed	01025100001400
Closed	01025100001500
Closed	01025100001600
Closed	01025100001700
Closed	01025100001800
Closed	01025100001900
Closed	01025100002000
Closed	01025100002100
Closed	01025100002200
Closed	01025100002300

Accessory Dwelling Units

Index # - File Name: 1.0022 - Single Family Dwellings Data\_Snohomish County.pdf

Closed	01025100002400
Closed	01025100002500
Closed	01025100002600
Closed	01025100002700
Closed	01025100002800
Closed	01025100002900
Closed	01025100003000
Closed	01025100003100
Closed	01025100003200
Closed	01025100003300
Closed	01025100003400
Closed	01025100003500
Closed	01025100003600
Closed	01025100003700
Closed	01025100003800
Closed	01025100003900
Closed	01025100004000
Closed	01025100004100
Closed	01025100004200
Closed	01025100004300
Closed	01025100004400
Closed	01025100004500
Closed	01025100004600
Closed	01025100004700
Closed	01025100004800
Closed	01025100004900
Closed	01025100005000
Closed	01025100005100
Closed	01025100005200
Closed	01025100005300
Closed	01025100005400
Closed	01025100005500
Closed	01025100005600
Closed	01025100005700
Closed	01025100005800
Closed	01025100005900
Closed	01025100006000
Closed	01025100006100
Closed	01025100006200
Closed	01025100006300
Closed	01025100006400
Closed	01025100006500
Closed	01025100006600
Closed	01025100006700
Closed	01025100006800
Closed	01025100006900
Closed	01025100007000

Accessory Dwelling Units

Index # - File Name: 1.0022 - Single Family Dwellings Data\_Snohomish County.pdf

Closed	01025100007100
Closed	01025100007200
Closed	01025100007300
Closed	01025100007400
Closed	01025100007500
Closed	01025100007600
Closed	01025100007700
Closed	01025100007800
Closed	01025100007900
Closed	01025100008000
Closed	01025100008100
Closed	01025100008200
Closed	01025100008300
Closed	01025100008400
Closed	01025100008500
Closed	01025100008600
Closed	01025100008700
Closed	01025100008800
Closed	01025100008900
Closed	01025100009000
Closed	01025100009100
Closed	01025100009200
Closed	01025100009300
Closed	01025100009400
Closed	01025100009500
Closed	01025100009600
Closed	01025100009700
Closed	01025100009800
Closed	01025100009900
Closed	01025100010000
Closed	01025100010100
Closed	01025100010200
Closed	01025100010300
Closed	01025100010400
Closed	01025100010500
Closed	01025100010600
Closed	01025100010700
Closed	01025100010800
Closed	01025100010900
Closed	01025100011000
Closed	01025100011100
Closed	01025100011200
Closed	01025100011300
Closed	01025100011400
Closed	01025100011500
Closed	01025100011600
Closed	01025100011700



Accessory Dwelling Units

Index # - File Name: 1.0022 - Single Family Dwellings Data\_Snohomish County.pdf

Closed	01025100011800
Closed	01025100011900
Closed	01025100012000
Closed	01025100012100
Closed	01025100012200
Closed	01025100012300
Closed	01025100012400
Closed	01025100012500
Closed	01025100012600
Closed	01025100012700
Closed	01025100012800
Closed	01025100012900
Closed	01026900102400
Closed	01026900102500
Closed	01026900102600
Closed	01026900102700
Closed	01026900102800
Closed	01026900102900
Closed	01026900103000
Closed	01026900103100
Closed	01026900103200
Closed	31042300301600
Closed	01026900106200
Closed	01026900106300
Closed	27062700400400
Closed	28051100404800
Closed	00499100106900
Closed	29062300301200
Closed	00516700005900
Closed	28081800301400
Closed	29061000301100
Closed	01024300000800
Closed	01024300000900
Closed	01024300001000
Closed	01024300001700
Closed	01024300001800
Closed	01024300001900
Closed	01024300002000
Closed	01024300000600
Closed	01024300002300
Closed	01024300002700
Closed	01024300002800
Closed	01024300002900
Closed	01024300003000
Closed	01024300003100
Closed	01024300004400
Closed	01024300004500

Accessory Dwelling Units

Index # - File Name: 1.0022 - Single Family Dwellings Data\_Snohomish County.pdf

Closed	01024300004600
Closed	01024300004700
Closed	01024300005000
Closed	01024300005100
Closed	01024300005200
Closed	01024300005300
Closed	01024300005400
Closed	01024300005500
Closed	31051700102900
Closed	28072600400200
Closed	01024800000100
Closed	01024300002500
Closed	01024800000700
Closed	01024800000800
Closed	01024800001800
Closed	01024800001900
Closed	01024800002000
Closed	01024800002100
Closed	01024800002300
Closed	27050700202500
Closed	31053100400900
Closed	01029900000100
Closed	01029900000200
Closed	01029900000300
Closed	01029900000400
Closed	01029900000500
Closed	01029900000600
Closed	00375000000401
Closed	00375000000402
Closed	00375000000403
Closed	00375000000404
Closed	00375000000405
Closed	00375000000407
Closed	00375000000408
Closed	01028800000200
Closed	01028800000300
Closed	01028800000400
Closed	01028800000500
Closed	01028800000600
Closed	01028800000700
Closed	01028800000800
Closed	01028800000900
Closed	01028800001000
Closed	01028800001100
Closed	01028800001200
Closed	01024900000100
Closed	01024900000200

Accessory Dwelling Units

Index # - File Name: 1.0022 - Single Family Dwellings Data\_Snohomish County.pdf

Closed	0102490000300
Closed	0102490000400
Closed	0102490000500
Closed	0102490000700
Closed	0102490000800
Closed	0102490000900
Closed	0102490001000
Closed	0102490001100
Closed	0102490001200
Closed	0102490001300
Closed	0102490001400
Closed	0102490001500
Closed	0102490001600
Closed	0102490001700
Closed	0102490001800
Closed	0102490002000
Closed	0102490002100
Closed	0102490002200
Closed	0102490002300
Closed	0102490002400
Closed	0102490002500
Closed	0102490002600
Closed	0102490002700
Closed	0102490002800
Closed	0053380001202
Closed	00489100006800
Closed	32053300203600
Closed	27071100300400
Closed	0102500000100
Closed	0102500000200
Closed	0102500000300
Closed	0102500000400
Closed	0102500000500
Closed	0102500000600
Closed	28072800301900
Closed	31060600203600
Closed	31060600203700
Closed	31060600203800
Closed	01024800001600
Closed	01025000003000
Closed	01025000003100
Closed	01025000003200
Closed	01025000003300
Closed	01025000003400
Closed	01025000003500
Closed	01025000003600
Closed	27052800404400

Accessory Dwelling Units

Index # - File Name: 1.0022 - Single Family Dwellings Data\_Snohomish County.pdf

Closed	01028100000100
Closed	01028100000200
Closed	01028100000300
Closed	01028100000400
Closed	01028100000500
Closed	01028100000600
Closed	01028100000700
Closed	01028100000800
Closed	01028100000900
Closed	01028100001000
Closed	01028100001100
Closed	01028100001200
Closed	01028100001300
Closed	01028100001400
Closed	01028100001500
Closed	01028100001600
Closed	01028100001700
Closed	01028100001800
Closed	01028100001900
Closed	01028100002000
Closed	01028100002100
Closed	01026800000100
Closed	01026800000200
Closed	01026800000300
Closed	01026800000400
Closed	01026800000500
Closed	01026800000600
Closed	01026800000700
Closed	01026800000800
Closed	01026800000900
Closed	01026800001000
Closed	01026800001100
Closed	01026800001200
Closed	01026800001400
Closed	01026800001500
Closed	01026800001600
Closed	01026800001900
Closed	01026800002000
Closed	01026800002100
Closed	01026800002200
Closed	01026800002300
Closed	01026800002400
Closed	01026800002500
Closed	01026800002600
Closed	01026800002700
Closed	01026800002800
Closed	01026800002900

Accessory Dwelling Units

Index # - File Name: 1.0022 - Single Family Dwellings Data\_Snohomish County.pdf

Closed	01026800003000
Closed	01026800003100
Closed	01026800003200
Closed	01026800003300
Closed	01026800003400
Closed	01026800003500
Closed	01026800003600
Closed	01026800003700
Closed	01026800003800
Closed	01026800003900
Closed	01026800004000
Closed	01026800004100
Closed	01026800004200
Closed	01026800004500
Closed	01026800004600
Closed	01026800004700
Closed	01026800004800
Closed	01026800004900
Closed	01026800005000
Closed	01026800005100
Closed	01026800005200
Closed	01026800005300
Closed	01026800005400
Closed	01026800005500
Closed	01026800005600
Closed	01026800005700
Closed	01026800005800
Closed	01026800005900
Closed	01026800006000
Closed	01026800006200
Closed	01026800006300
Closed	01026800006400
Closed	01026800006500
Closed	01026800006600
Closed	01026800006700
Closed	01026800006800
Closed	01026800006900
Closed	01026800007000
Closed	01026800007100
Closed	01026800007200
Closed	01026800007300
Closed	01026800007500
Closed	01026800007600
Closed	01026800007700
Closed	00609500000201
Closed	01027300000100
Closed	01027300000200

Accessory Dwelling Units

Index # - File Name: 1.0022 - Single Family Dwellings Data\_Snohomish County.pdf

Closed	01027300000300
Closed	01027300000400
Closed	01027300000500
Closed	01027300000600
Closed	01027300000700
Closed	01027300000800
Closed	01027300000900
Closed	01027300001000
Closed	01027300001100
Closed	01027300001200
Closed	01027300001300
Closed	01027300001400
Closed	01027300001500
Closed	01027300001600
Closed	01027300001700
Closed	01027300001800
Closed	01027300001900
Closed	01027300002000
Closed	01027300002100
Closed	01027300002200
Closed	01027300002300
Closed	01027300002400
Closed	01027300002500
Closed	01027300002600
Closed	01027300002700
Closed	01027300002800
Closed	01027300002900
Closed	01027300003000
Closed	01027300003100
Closed	01027300003200
Closed	01027300003300
Closed	01027300003400
Closed	01027300003500
Closed	01027300003600
Closed	01027300003700
Closed	01027300003800
Closed	01027300003900
Closed	01027300004000
Closed	01027300004100
Closed	01027300004200
Closed	01027300004300
Closed	01027300004400
Closed	01027300004500
Closed	01027300004600
Closed	01019900004300
Closed	01019900004400
Closed	01019900004600

Accessory Dwelling Units

Index # - File Name: 1.0022 - Single Family Dwellings Data\_Snohomish County.pdf

Closed	01019900004700
Closed	01019900004800
Closed	01019900004900
Closed	01019900005000
Closed	01019900005100
Closed	01019900005200
Closed	01019900005300
Closed	01019500000100
Closed	01019500000200
Closed	01019500000300
Closed	01019500000400
Closed	01019500000500
Closed	01019500000600
Closed	01019500000700
Closed	01019500000800
Closed	01019500000900
Closed	01019500001000
Closed	01019500001100
Closed	01019500001200
Closed	01019500001300
Closed	01019500001400
Closed	01019500001500
Closed	01019500001600
Closed	01019500001700
Closed	01019500001800
Closed	01019500001900
Closed	01019500002000
Closed	01019500002100
Closed	01019500002200
Closed	01019500002300
Closed	01019500002400
Closed	01019500002500
Closed	01019500002600
Closed	01019500002700
Closed	01019500002800
Closed	01019500002900
Closed	01019500003000
Closed	01019500003100
Closed	01020700001100
Closed	01020700001200
Closed	01020700001300
Closed	01020700001400
Closed	01020700001500
Closed	01020700001600
Closed	01020700001700
Closed	01020700001800
Closed	01020700001900

Accessory Dwelling Units

Index # - File Name: 1.0022 - Single Family Dwellings Data\_Snohomish County.pdf

Closed	01020700002000
Closed	01020700002100
Closed	01020700002200
Closed	01020700002300
Closed	01020700002400
Closed	01020700002500
Closed	01020700002600
Closed	01020700002700
Closed	01020700002800
Closed	01020700002900
Closed	01020700003000
Closed	01020700003100
Closed	01019900000100
Closed	01019900000200
Closed	01019900000300
Closed	01019900000400
Closed	01019900000500
Closed	01019900000600
Closed	01019900000700
Closed	01019900000800
Closed	01019900000900
Closed	01019900001000
Closed	01019900001100
Closed	01019900001200
Closed	01019900001300
Closed	01019900001400
Closed	01019900001500
Closed	01019900001600
Closed	01019900001700
Closed	01019900001800
Closed	01019900001900
Closed	01019900002000
Closed	01019900002100
Closed	01019900002200
Closed	01019900002300
Closed	01019900002400
Closed	01019900002500
Closed	01019900002600
Closed	01019900002700
Closed	01019900002800
Closed	01019900002900
Closed	01019900003000
Closed	01019900003100
Closed	01019900003200
Closed	01019900003300
Closed	01019900003400
Closed	01019900003500



Accessory Dwelling Units

Index # - File Name: 1.0022 - Single Family Dwellings Data\_Snohomish County.pdf

Closed	27071100300900
Closed	01020100000400
Closed	01018800000100
Closed	01018800000200
Closed	01018800000300
Closed	01045700100200
Closed	01045700200200
Closed	01045700300100
Closed	00557600003300
Closed	31060600400200
Closed	32081000201500
Closed	30061800202500
Closed	01020100000100
Closed	01021500003500
Closed	01021500003600
Closed	01021500003800
Closed	01021500005100
Closed	01021500005200
Closed	01021500005300
Closed	01021500001500
Closed	01021500001000
Closed	01018700000100
Closed	01018700000300
Closed	01018700000400
Closed	01018700000500
Closed	01018700000600
Closed	01018700000700
Closed	01018700000800
Closed	01018700000900
Closed	01018700001000
Closed	01018700001100
Closed	01018700001200
Closed	01018700001300
Closed	01018700001400
Closed	01021500001800
Closed	01021500001900
Closed	01021500002000
Closed	01021500002100
Closed	01021500002200
Closed	01021500002300
Closed	01021500002500
Closed	01021500002600
Closed	01021500002700
Closed	01021500002800
Closed	01021500002900
Closed	01021500003000
Closed	01021500003100

Accessory Dwelling Units

Index # - File Name: 1.0022 - Single Family Dwellings Data\_Snohomish County.pdf

Closed	01021500003200
Closed	01018700004000
Closed	01018700004100
Closed	01018700004200
Closed	01018700004300
Closed	01018700004400
Closed	01018700004500
Closed	01018700004600
Closed	01018700004700
Closed	01018700004800
Closed	01018700004900
Closed	01018700005000
Closed	01018700005100
Closed	01021500000100
Closed	01021500000200
Closed	01021500000300
Closed	01021500000400
Closed	01018700001700
Closed	01018700001800
Closed	01018700001900
Closed	01018700002000
Closed	01018700002100
Closed	01018700002200
Closed	01018700002300
Closed	01018700002400
Closed	01018700002500
Closed	01018700002600
Closed	01018700002700
Closed	01018700002800
Closed	01018700002900
Closed	01018700003000
Closed	01018700003100
Closed	01018700003200
Closed	01018700003300
Closed	01018700003400
Closed	01018700003500
Closed	01018700003700
Closed	01017000001000
Closed	01017000001100
Closed	01017000001200
Closed	00579100002205
Closed	01016300000100
Closed	01017000000300
Closed	01017000000400
Closed	01017000000600
Closed	01017000000700
Closed	01017000000800

Accessory Dwelling Units

Index # - File Name: 1.0022 - Single Family Dwellings Data\_Snohomish County.pdf

Closed	01017000001500
Closed	01017000001600
Closed	01017000001700
Closed	01017000001800
Closed	01017000001900
Closed	01017000002000
Closed	01017000002100
Closed	01017000002200
Closed	01017000002300
Closed	01017000002400
Closed	01017000002500
Closed	01017000002600
Closed	01017000002700
Closed	01017000002800
Closed	31033600100600
Closed	30040100201400
Closed	01016300002400
Closed	01016300002500
Closed	01016300002600
Closed	01016300002700
Closed	01016300002800
Closed	01016300002900
Closed	01016300003000
Closed	01016300003100
Closed	01016300003200
Closed	01016300003300
Closed	01016300003400
Closed	01016300000600
Closed	01016300000700
Closed	01016300000800
Closed	01016300000900
Closed	01016300001000
Closed	01016300001100
Closed	01016300001200
Closed	01016300001300
Closed	01016300001400
Closed	01016300001500
Closed	01016300001600
Closed	01016300001700
Closed	01016300001800
Closed	01015500000400
Closed	01015500000500
Closed	01015500000600
Closed	01015500000700
Closed	01015500000800
Closed	01015500000900
Closed	01015500001000

Accessory Dwelling Units

Index # - File Name: 1.0022 - Single Family Dwellings Data\_Snohomish County.pdf

Closed	01015500001100
Closed	01015500001200
Closed	01015500000200
Closed	32042600200600
Closed	28061600301000
Closed	00579100002202
Closed	01024200000500
Closed	01024200000600
Closed	01024200000700
Closed	01024200000800
Closed	01024200000900
Closed	01024200001000
Closed	01024200001100
Closed	01024200001200
Closed	01024200001300
Closed	01024200001400
Closed	01024200001500
Closed	01024200001600
Closed	01024200001700
Closed	01024200001800
Closed	01024200001900
Closed	01024200002000
Closed	01024200002100
Closed	01024200002500
Closed	01024200002600
Closed	01024200002700
Closed	01024200002800
Closed	01024200002900
Closed	01024200003000
Closed	01024200003100
Closed	01024200003200
Closed	01024200003300
Closed	01024200003400
Closed	01024200003700
Closed	01024200003800
Closed	01024200003900
Closed	01024200004000
Closed	01024200004100
Closed	01024200004200
Closed	01024200004300
Closed	01024200004400
Closed	01024200004500
Closed	01024200004600
Closed	01024200004700
Closed	01024200004800
Closed	01024200004900
Closed	01024200005000

Accessory Dwelling Units

Index # - File Name: 1.0022 - Single Family Dwellings Data\_Snohomish County.pdf

Closed	31042300102100
Closed	01019800001700
Closed	28050300303900
Closed	01019800000200
Closed	01019800001500
Closed	01015800001900
Closed	01015800002000
Closed	01015800000700
Closed	01015800000800
Closed	01015800000900
Closed	00372800900605
Closed	00372800900606
Closed	01015800000100
Closed	01015800000200
Closed	01015800000300
Closed	27071900101400
Closed	00394507600201
Closed	28073300203700
Closed	00468700000400
Closed	30050200101300
Closed	28073300203300
Closed	32042300300200
Closed	32051800401500
Closed	01014700003000
Closed	30061700402800
Closed	30061700402900
Closed	30061700402400
Closed	30061700402500
Closed	01014700002700
Closed	01014700002700
Closed	01014700002800
Closed	01014700002300
Closed	01014700002400
Closed	01014500002900
Closed	01014700001800
Closed	01014700001900
Closed	01014700002000
Closed	01014700002100
Closed	01014700001400
Closed	01014700001500
Closed	01014700001600
Closed	01014700000100
Closed	01014700000200
Closed	01014700000300
Closed	01014700000400
Closed	01014700000500
Closed	01014700000600

Accessory Dwelling Units

Index # - File Name: 1.0022 - Single Family Dwellings Data\_Snohomish County.pdf

Closed	01014700000700
Closed	01014700000800
Closed	01014500003100
Closed	01014500003200
Closed	01014500003300
Closed	01014500001600
Closed	01014500001300
Closed	01014500002600
Closed	01014500002700
Closed	01014500001000
Closed	01014500001100
Closed	31061600200300
Closed	01014500000600
Closed	01014500000700
Closed	01014500000800
Closed	01014500000300
Closed	01013100001700
Closed	00394511100200
Closed	01017100004200
Closed	00401000008900
Closed	01017100003900
Closed	01017100004000
Closed	01013100008600
Closed	01013100008700
Closed	01017100003400
Closed	01017100003500
Closed	01017100003600
Closed	01017100003700
Closed	01013000002500
Closed	01013000002600
Closed	01013000002700
Closed	01013000002800
Closed	01013000002900
Closed	01017100003000
Closed	01017100003100
Closed	01017100003200
Closed	01017100000800
Closed	01017100000900
Closed	01017100001000
Closed	01013000001900
Closed	01013000002000
Closed	01013000002100
Closed	01013000002200
Closed	01013000000800
Closed	01013100009100
Closed	01013100005700
Closed	01013100005800

Accessory Dwelling Units

Index # - File Name: 1.0022 - Single Family Dwellings Data\_Snohomish County.pdf

Closed	01013100005900
Closed	01013100006000
Closed	01013100005200
Closed	01013100005300
Closed	01013100005400
Closed	01013100005500
Closed	01013100005000
Closed	01013100004800
Closed	01013100007200
Closed	01013100007300
Closed	01013100007400
Closed	01013100007500
Closed	01013100007600
Closed	01013100007700
Closed	01013100007800
Closed	01013100008000
Closed	01013100008100
Closed	01013100008200
Closed	01013100008300
Closed	01013100008400
Closed	01013100004500
Closed	32040500402000
Closed	01011500002100
Closed	01013100000700
Closed	01013100000800
Closed	01013100000900
Closed	01013100001000
Closed	01013100001100
Closed	01013100001200
Closed	01013100002200
Closed	01013100002300
Closed	01013100002400
Closed	01013100002500
Closed	01013100002600
Closed	01013100002700
Closed	01013100002800
Closed	01013100002900
Closed	01013100003000
Closed	01013100003100
Closed	01013100003200
Closed	01013100003300
Closed	01013100003400
Closed	01013100003500
Closed	01013100003600
Closed	01013100003700
Closed	01013100003800
Closed	01013100003900

Accessory Dwelling Units

Index # - File Name: 1.0022 - Single Family Dwellings Data\_Snohomish County.pdf

Closed	01013100004000
Closed	01013100004100
Closed	01013100004200
Closed	01013100004300
Closed	01013100000100
Closed	01012500001200
Closed	01012500001300
Closed	01012500002300
Closed	01012500000700
Closed	01012500000800
Closed	01012500000900
Closed	01012500000500
Closed	00385500102202
Closed	01011600000100
Closed	01011600000200
Closed	01011600000300
Closed	01011600000400
Closed	01011600000500
Closed	01011600000600
Closed	01011600000700
Closed	01011600000800
Closed	01011600000900
Closed	01011600001000
Closed	01011600001100
Closed	01011600001200
Closed	01011600001300
Closed	01011600001400
Closed	01011600001500
Closed	01011600001600
Closed	01011600001700
Closed	01011600001800
Closed	01011600001900
Closed	01011700008500
Closed	01011400001400
Closed	01011400001500
Closed	01011400001600
Closed	01011400001700
Closed	01011400001800
Closed	01011400000300
Closed	01011400000400
Closed	01011400000500
Closed	01011400000600
Closed	01011400000700
Closed	01011400000800
Closed	01011400000900
Closed	01011400001000
Closed	01011400001100



Accessory Dwelling Units

Index # - File Name: 1.0022 - Single Family Dwellings Data\_Snohomish County.pdf

Closed	01011400005400
Closed	01011400005500
Closed	01011400005600
Closed	01011400005700
Closed	01011400005800
Closed	01011400005900
Closed	01011400002900
Closed	01011400003000
Closed	01011400003100
Closed	01011400003200
Closed	01011400003300
Closed	01011400003400
Closed	01011400003500
Closed	01011400003600
Closed	01011400003700
Closed	01011400003800
Closed	01011400003900
Closed	01011400004000
Closed	01011400004100
Closed	01011700007700
Closed	01011700007800
Closed	01011700007900
Closed	01011700008000
Closed	01011700008100
Closed	01011700008200
Closed	01011700008300
Closed	01011700003300
Closed	01011700003400
Closed	01011700003500
Closed	01011700003600
Closed	01011700003700
Closed	01011700003800
Closed	01011700003900
Closed	01011700004000
Closed	01011700004100
Closed	01011700004200
Closed	01011700004300
Closed	01011700000100
Closed	01011700000200
Closed	32063600202900
Closed	01011900001500
Closed	01011900000100
Closed	01011900001300
Closed	01011900000700
Closed	01011900000800
Closed	01011800003700
Closed	01011800003500

Accessory Dwelling Units

Index # - File Name: 1.0022 - Single Family Dwellings Data\_Snohomish County.pdf

Closed	01011800002400
Closed	01011800002500
Closed	01011800002600
Closed	01011800002700
Closed	01011800002800
Closed	01011800002900
Closed	01011800003100
Closed	01011800003200
Closed	01011800001900
Closed	01011800001700
Closed	01011800001200
Closed	01011800001400
Closed	01011800001500
Closed	01011800000600
Closed	01011800000800
Closed	01011800000900
Closed	01010700000300
Closed	01010700000400
Closed	01010700000500
Closed	01010700000600
Closed	01010700000700
Closed	01010700000800
Closed	01011800000100
Closed	01011800000200
Closed	01011800000300
Closed	01011100001900
Closed	01011100002000
Closed	01010700000100
Closed	01010700000200
Closed	01011100001700
Closed	01011100000800
Closed	01011100000900
Closed	01011100000400
Closed	29061500101200
Closed	00394402503600
Closed	01011100000100
Closed	01011100000200
Closed	01010600000600
Closed	01010600000700
Closed	01010600000300
Closed	27051100105600
Closed	01010100000300
Closed	01010100000400
Closed	01010100000500
Closed	01010100000600
Closed	01010100000700
Closed	28083400100500

Accessory Dwelling Units

Index # - File Name: 1.0022 - Single Family Dwellings Data\_Snohomish County.pdf

Closed	01010100003500
Closed	01010100003600
Closed	01010100003800
Closed	01010100003900
Closed	01010100004000
Closed	01010100004100
Closed	01010100004600
Closed	01010100004700
Closed	01010100004800
Closed	01010100004900
Closed	01027100000500
Closed	01027100000600
Closed	01027100000700
Closed	01027100000800
Closed	01027100000900
Closed	01027100001000
Closed	30063500300600
Closed	29071900301600
Closed	30051500201000
Closed	30051500201000
Closed	30051500201000
Closed	30051500201000
Closed	30051500201000
Closed	30051500201000
Closed	30051500201000
Closed	30051500201000
Closed	30051500201000
Closed	30051500201000
Closed	01027000000100
Closed	01027000000200
Closed	01027000000300
Closed	01027000000400
Closed	01027000000500
Closed	01027000000600
Closed	01033600001800
Closed	29062000211300
Closed	32041700202100
Closed	27071100300600
Closed	01032300000100
Closed	01032300000200
Closed	01032300000300
Closed	01032300000400
Closed	01032300000500
Closed	01032300000600
Closed	01032300000700
Closed	01032300000800
Closed	01032300000900
Closed	01032300001000
Closed	01032300001100

Accessory Dwelling Units

Index # - File Name: 1.0022 - Single Family Dwellings Data\_Snohomish County.pdf

Closed	01032300001200
Closed	01032300001300
Closed	01032300001400
Closed	01032300001500
Closed	01032300001600
Closed	01032300001700
Closed	01032300001800
Closed	01032300001900
Closed	01032300002000
Closed	01032300002100
Closed	01032300002200
Closed	01032300002300
Closed	01032300002400
Closed	01027300004800
Closed	01027300004900
Closed	01027300005000
Closed	01027300005100
Closed	01027300005200
Closed	01027300005300
Closed	01027300005400
Closed	30060100201100
Closed	00394401500006
Closed	28062900402800
Closed	01029200000400
Closed	01029200000800
Closed	01029200000900
Closed	01029200001000
Closed	01028600000100
Closed	01028600000200
Closed	01028600000300
Closed	01028600000400
Closed	01028600000500
Closed	01028600000600
Closed	01028600000700
Closed	01028600000800
Closed	01028600001000
Closed	28061700206600
Closed	30050900410200
Closed	30050900410300
Closed	00372801202101
Closed	00372801202101
Closed	00372801202105
Closed	00372801202101
Closed	00372801202101
Closed	00372801202101
Closed	01029300000100
Closed	01029300000200

Accessory Dwelling Units

Index # - File Name: 1.0022 - Single Family Dwellings Data\_Snohomish County.pdf

Closed	01029300000300
Closed	01029300000400
Closed	01029300000500
Closed	01029300000600
Closed	01028600001900
Closed	01028600002000
Closed	01028600002100
Closed	01028600002300
Closed	01029300001000
Closed	01029300001100
Closed	01029300001200
Closed	01029300001300
Closed	01029300001400
Closed	01029300001800
Closed	01029300001900
Closed	01029300002000
Closed	01029300002100
Closed	01029300002200
Closed	01029300002300
Closed	01029300002400
Closed	01029300002500
Closed	01029300002600
Closed	01029300002700
Closed	01029300002800
Closed	01029300002900
Closed	01029300003000
Closed	01029300003100
Closed	01029300003200
Closed	01029300003300
Closed	01029300003400
Closed	01029300003500
Closed	01029300003700
Closed	01029300003800
Closed	01029300003900
Closed	01029300004000
Closed	01029300004100
Closed	01029300004200
Closed	01029300004300
Closed	01029300004400
Closed	32052200103100
Closed	01028600001400
Closed	01029300004600
Closed	01029300004700
Closed	01029300004800
Closed	01029300004900
Closed	01029300005000
Closed	01029300005100

Accessory Dwelling Units

Index # - File Name: 1.0022 - Single Family Dwellings Data\_Snohomish County.pdf

Closed	01028600001600
Closed	01029300005300
Closed	01029300005700
Closed	01029300005800
Closed	01029300005900
Closed	01029300006200
Closed	01029300006300
Closed	01029300006400
Closed	01029300006500
Closed	01029300006600
Closed	01029300007500
Closed	01029300007600
Closed	01029300007700
Closed	01029300007800
Closed	01029300008000
Closed	01028700000200
Closed	01028700000300
Closed	01028700000500
Closed	01028700000600
Closed	01028700000700
Closed	01028700000800
Closed	01028700000900
Closed	01028700001000
Closed	01029000000300
Closed	01029000000400
Closed	01029000000500
Closed	01029000000600
Closed	01029000000700
Closed	01029000000800
Closed	01029000000900
Closed	01029000001000
Closed	01029000001100
Closed	01029000001200
Closed	01029000001300
Closed	01029000001500
Closed	01029000001600
Closed	01029000001700
Closed	01029000001800
Closed	01029000001900
Closed	01029000002000
Closed	01029000002100
Closed	01029000002200
Closed	01029000002300
Closed	01029000002500
Closed	01029000002700
Closed	01029000002800
Closed	01029000002900

Accessory Dwelling Units

Index # - File Name: 1.0022 - Single Family Dwellings Data\_Snohomish County.pdf

Closed	01029000003000
Closed	01029000003100
Closed	01029000003200
Closed	01029000003300
Closed	01029000003400
Closed	01029000003500
Closed	01029000003600
Closed	01029000003700
Closed	01029000003800
Closed	01029000003900
Closed	01029000004000
Closed	01029000004100
Closed	01029300007000
Closed	01029300007100
Closed	01029300007200
Closed	01029300007300
Closed	01029100000700
Closed	01029100000800
Closed	01029100000900
Closed	01029100001000
Closed	01029100001100
Closed	01029100001200
Closed	01029100001300
Closed	01040300000600
Closed	01040300000700
Closed	01040300000800
Closed	01040300000900
Closed	01040300001000
Closed	01040300001100
Closed	01040300001200
Closed	01040300001300
Closed	01040300001400
Closed	01040300001500
Closed	01040300001600
Closed	01040300001700
Closed	01040300001800
Closed	01029800001900
Closed	01029800002000
Closed	01029800002100
Closed	01029800002200
Closed	01029800002600
Closed	01029800002700
Closed	01029800002800
Closed	01029800002900
Closed	01029800003000
Closed	01029800003100
Closed	01029800003200

Accessory Dwelling Units

Index # - File Name: 1.0022 - Single Family Dwellings Data\_Snohomish County.pdf

Closed	01029800003300
Closed	01029800003400
Closed	01029800003500
Closed	01029800003600
Closed	01029800003700
Closed	01029800003800
Closed	01029800003900
Closed	01029800004000
Closed	01029800004100
Closed	01029800004200
Closed	01029800004300
Closed	01029800004400
Closed	01029800004500
Closed	01029800004600
Closed	01029800004700
Closed	01029800004800
Closed	01029800005000
Closed	01029800005100
Closed	01029800005200
Closed	01029800005300
Closed	27071100300100
Closed	01031900000100
Closed	01031900000200
Closed	01031900000300
Closed	01031900000400
Closed	01031900000500
Closed	01031900000600
Closed	01031900000700
Closed	01031900000800
Closed	01031900000900
Closed	01031900001000
Closed	01031900001200
Closed	01031900001300
Closed	01029100000200
Closed	01029100000300
Closed	01029100000400
Closed	01029100000500
Closed	01029100001600
Closed	01029100001700
Closed	01029100001800
Closed	01040300000100
Closed	01040300000200
Closed	01040300000300
Closed	01040300000400
Closed	01031900002900
Closed	01031900005000
Closed	01031900005100



Accessory Dwelling Units

Index # - File Name: 1.0022 - Single Family Dwellings Data\_Snohomish County.pdf

Closed	01031900005200
Closed	01031900005300
Closed	01031900005400
Closed	01031900005500
Closed	01031900005600
Closed	01031900005700
Closed	01031900005800
Closed	01031900005900
Closed	01031900006000
Closed	01031900006100
Closed	01031900006200
Closed	01031900006300
Closed	01031900006400
Closed	01031900006500
Closed	01031900006600
Closed	01031900006700
Closed	01031900006800
Closed	01031900006900
Closed	01031900007000
Closed	01031900007100
Closed	01031900007200
Closed	01031900007300
Closed	01031900004200
Closed	01031900004300
Closed	01031900004400
Closed	01031900004500
Closed	01031900004600
Closed	01031900004700
Closed	01031900004800
Closed	01031900003500
Closed	01031900003700
Closed	01031900003800
Closed	01031900003900
Closed	01031900004000
Closed	01031900007500
Closed	01031900007700
Closed	01031900007800
Closed	01031900007900
Closed	01031900008100
Closed	01028900000100
Closed	01028900000200
Closed	01028900000300
Closed	01028900000400
Closed	01028900000500
Closed	01028900000600
Closed	01028900000700
Closed	01028900000800

Accessory Dwelling Units

Index # - File Name: 1.0022 - Single Family Dwellings Data\_Snohomish County.pdf

Closed	01028900000900
Closed	01028900001000
Closed	01028900001100
Closed	01028900001200
Closed	01028900001300
Closed	01028900001400
Closed	01028900001500
Closed	01028900001600
Closed	01028900001700
Closed	01028900001800
Closed	01028900001900
Closed	01028900002000
Closed	01028900002100
Closed	01028900002200
Closed	01028900002300
Closed	01028900002400
Closed	01028900002500
Closed	01028900002600
Closed	01028900002700
Closed	01028900002800
Closed	01028900003000
Closed	01028900003100
Closed	01028900003200
Closed	01028900003300
Closed	01028900003400
Closed	01028900003500
Closed	01028900003600
Closed	01028900003700
Closed	01028900003800
Closed	01028900003900
Closed	01028900004100
Closed	01028900004200
Closed	01028900004300
Closed	01028900004400
Closed	01028900004500
Closed	01028900004600
Closed	01028900004700
Closed	01028900004800
Closed	01028900004900
Closed	01028900005000
Closed	01028900005100
Closed	01028900005200
Closed	01028900005300
Closed	01028900005400
Closed	01028900005500
Closed	01030700000100
Closed	01030700000200

Accessory Dwelling Units

Index # - File Name: 1.0022 - Single Family Dwellings Data\_Snohomish County.pdf

Closed	0103070000300
Closed	0103070000400
Closed	0103070000500
Closed	0103070000600
Closed	0103070000700
Closed	0103070000800
Closed	0103070000900
Closed	0103070001000
Closed	0103070001100
Closed	0103070001200
Closed	0103070001300
Closed	0103070001400
Closed	0103070001500
Closed	0103070001600
Closed	0103070002100
Closed	0103070002300
Closed	0103070002400
Closed	0103070002500
Closed	0103070002600
Closed	0103070002900
Closed	0103070003000
Closed	0103070003100
Closed	0103070003200
Closed	0103070003300
Closed	0103070003400
Closed	0103070003500
Closed	0103070003700
Closed	0103070003900
Closed	0103070004000
Closed	0103070004100
Closed	0103070004200
Closed	0103070004300
Closed	0103070004400
Closed	0103070004500
Closed	0103070004600
Closed	0103070004700
Closed	0103070004800
Closed	0103070004900
Closed	0103070005000
Closed	0103070005100
Closed	0103070005200
Closed	0103070005300
Closed	0103070005400
Closed	0103070005500
Closed	0103070005600
Closed	0103070005700
Closed	0103070005800

Accessory Dwelling Units

Index # - File Name: 1.0022 - Single Family Dwellings Data\_Snohomish County.pdf

Closed	01030700005900
Closed	01030100000200
Closed	01030100000300
Closed	01030100000400
Closed	01030100000500
Closed	01030100000600
Closed	01030100000700
Closed	01030100000800
Closed	01030100000900
Closed	01030100001000
Closed	01030100001100
Closed	01030100001200
Closed	01030100001300
Closed	00394403706400
Closed	00394403701600
Closed	29062600303500
Closed	28060800401200
Closed	00374800003402
Closed	00374800003403
Closed	01030800000100
Closed	01030800000200
Closed	01030800000300
Closed	01030800000400
Closed	01030800000500
Closed	01030800000600
Closed	01030800000700
Closed	01030800000800
Closed	01030800000900
Closed	01030800001000
Closed	29062400301700
Closed	28073000203600
Closed	28073000203700
Closed	01031800000100
Closed	01031800000200
Closed	01031800000300
Closed	01031800000400
Closed	01031800000500
Closed	01031800000600
Closed	01031800000700
Closed	01031800000800
Closed	01031800000900
Closed	28062400402700
Closed	00493900002700
Closed	01031200000100
Closed	01031200000200
Closed	01031200000300
Closed	01031200000400

Accessory Dwelling Units

Index # - File Name: 1.0022 - Single Family Dwellings Data\_Snohomish County.pdf

Closed	01031200000500
Closed	01031200000600
Closed	01031200000700
Closed	01031200000800
Closed	01031200000900
Closed	01031200001000
Closed	01031200001100
Closed	01031200001500
Closed	01031200001700
Closed	01031200001800
Closed	01031200001900
Closed	01031200002000
Closed	01031200002100
Closed	01031200002200
Closed	01031200002300
Closed	01031200002500
Closed	01031200002600
Closed	01031200002700
Closed	01031200002800
Closed	01031200002900
Closed	01031200003000
Closed	01031200003100
Closed	00570600100101
Closed	00570600100102
Closed	00512000205500
Closed	01031900002600
Closed	00442900201902
Closed	00394401700100
Closed	32041000100300
Closed	28062200100600
Closed	28073000105000
Closed	00373701600204
Closed	00557300202400
Closed	29060600200500
Closed	28070600402700
Closed	32091100400100
Closed	00590700014500
Closed	32090800100600
Closed	01034500000300
Closed	01034500000400
Closed	01034500002200
Closed	01033600000100
Closed	01033600000200
Closed	01033600000300
Closed	01033600000400
Closed	01033600000500
Closed	01033600000600

Accessory Dwelling Units

Index # - File Name: 1.0022 - Single Family Dwellings Data\_Snohomish County.pdf

Closed	01033600000700
Closed	01033600000800
Closed	01033600000900
Closed	01033600001900
Closed	01033600002000
Closed	01033600003200
Closed	01033600003300
Closed	01033600003400
Closed	01033600003500
Closed	01033600003700
Closed	01033600003800
Closed	01033600003900
Closed	01033600004000
Closed	01033600004100
Closed	01033600004200
Closed	01033600004300
Closed	01033600004400
Closed	01033600004500
Closed	01033600004600
Closed	01033600004700
Closed	01033600004800
Closed	01033600004900
Closed	01033600005000
Closed	01033600005100
Closed	01033600005200
Closed	01033600005300
Closed	01033600005400
Closed	01033600005500
Closed	01033600005600
Closed	01033600005700
Closed	01033600005800
Closed	01033600005900
Closed	01033600006000
Closed	01033600006100
Closed	01033600006200
Closed	01033600006300
Closed	01033600006400
Closed	01033600006500
Closed	01033600006600
Closed	01033600006700
Closed	01033600006800
Closed	01033600006900
Closed	01033600007000
Closed	01033600007100
Closed	01033600007200
Closed	01033600007300
Closed	32052100203000

Accessory Dwelling Units

Index # - File Name: 1.0022 - Single Family Dwellings Data\_Snohomish County.pdf

Closed	00597400003302
Closed	01034800000200
Closed	01034800000300
Closed	01034800000400
Closed	01034800000500
Closed	01034800000600
Closed	01034800000700
Closed	01034800000800
Closed	01034800001000
Closed	01034800001200
Closed	01034800001300
Closed	01034800001400
Closed	01034800001500
Closed	01034800001600
Closed	01034800001700
Closed	01034800001800
Closed	01034800001900
Closed	01034800002000
Closed	01034800002100
Closed	01034800002200
Closed	01034800002300
Closed	01034500003100
Closed	01034500003800
Closed	01034800002500
Closed	01034800002600
Closed	01034800002700
Closed	00373100200801
Closed	29061300202400
Closed	00509400003206
Closed	00509400003207
Closed	00509400003208
Closed	00509400003209
Closed	00509400003210
Closed	00509400003211
Closed	31050500103000
Closed	01034100000100
Closed	01034100000200
Closed	01034100000300
Closed	01034100000400
Closed	01034100000500
Closed	01034100000600
Closed	01034100000700
Closed	01034100000800
Closed	01034100000900
Closed	01034100001000
Closed	01034100001100
Closed	01034500003500

Accessory Dwelling Units

Index # - File Name: 1.0022 - Single Family Dwellings Data\_Snohomish County.pdf

Closed	31061700202300
Closed	01034100003300
Closed	01034100003400
Closed	01034100003500
Closed	01034100003600
Closed	01034100003700
Closed	01034100003800
Closed	01034100003900
Closed	01034100004000
Closed	01034100004100
Closed	01034100005500
Closed	01034100005600
Closed	01034100005700
Closed	01034100005800
Closed	01034100005900
Closed	01034100006000
Closed	01034100006100
Closed	01034100006200
Closed	00538500000703
Closed	00704100000100
Closed	00373700801501
Closed	00373700801503
Closed	00373700801504
Closed	00373700801505
Closed	00373700801506
Closed	00373700801507
Closed	00394403900100
Closed	01033100000100
Closed	29063500401200
Closed	01033100000200
Closed	01033100000300
Closed	01033100000400
Closed	01033100000500
Closed	01033100000600
Closed	01033100000700
Closed	01033100000800
Closed	01033100000900
Closed	01033100001000
Closed	01033100001100
Closed	01033100001300
Closed	01033100001400
Closed	01033700000100
Closed	01033700000200
Closed	01033700000300
Closed	01033700000400
Closed	01033700000500
Closed	01033700000600



Accessory Dwelling Units

Index # - File Name: 1.0022 - Single Family Dwellings Data\_Snohomish County.pdf

Closed	0103370000700
Closed	0103370000800
Closed	01033700001200
Closed	01033700001300
Closed	01033700001400
Closed	01033700001500
Closed	01033700001600
Closed	01033700001700
Closed	01033700001800
Closed	01033700001900
Closed	01033700002000
Closed	01033700002100
Closed	01033700002200
Closed	01033700002300
Closed	01033700001000
Closed	01033700002600
Closed	01033100002800
Closed	01033100002900
Closed	01033100003000
Closed	01033100003100
Closed	01033100003200
Closed	28072900101200
Closed	00489100006400
Closed	00373700801503
Closed	00373700801504
Closed	00397700001100
Closed	01035300002400
Closed	01035300002800
Closed	01035300002900
Closed	01035300003000
Closed	01035300003200
Closed	01039100000600
Closed	01039100000800
Closed	01039100000900
Closed	01039100001000
Closed	01039100001100
Closed	01039100001400
Closed	01039100001700
Closed	01039100002000
Closed	01039100002200
Closed	01039100003500
Closed	01039100003600
Closed	01039100003700
Closed	01039100003800
Closed	01039100003900
Closed	01039100004000
Closed	01039100004100

Accessory Dwelling Units

Index # - File Name: 1.0022 - Single Family Dwellings Data\_Snohomish County.pdf

Closed	01039100004700
Closed	01039100004300
Closed	01039100004400
Closed	01039100004500
Closed	01039100004600
Closed	01039100004200
Closed	01039100004800
Closed	01039100004900
Closed	01039100005000
Closed	01039100005100
Closed	01039100005200
Closed	01039100005300
Closed	28050300202500
Closed	28050300202500
Closed	27060500102300
Closed	01039100002400
Closed	01039100002500
Closed	01039100002600
Closed	01039100002700
Closed	01039100002800
Closed	27063400402500
Closed	01039100003200
Closed	00394400802901
Closed	27063400100900
Closed	32052000402100
Closed	30071900104500
Closed	01034400000300
Closed	29063300201400
Closed	28070600300300
Closed	28061400402600
Closed	01036400000100
Closed	01036400001800
Closed	01036400003000
Closed	00538500000701
Closed	00373700601507
Closed	00373700601508
Closed	00373700601509
Closed	00373700601510
Closed	00373700601511
Closed	01035800001000
Closed	01035800001200
Closed	01035800001300
Closed	01035800001800
Closed	01035800001900
Closed	01035800002000
Closed	01035800002100
Closed	01035800002200

Accessory Dwelling Units

Index # - File Name: 1.0022 - Single Family Dwellings Data\_Snohomish County.pdf

Closed	01035800002300
Closed	01035800002400
Closed	01035800002500
Closed	01035800002600
Closed	01035800002700
Closed	01035800001500
Closed	01035800001600
Closed	01036500000500
Closed	01036500000600
Closed	01036500001800
Closed	01037300000100
Closed	01037300000200
Closed	01037300000300
Closed	01037300000400
Closed	01037300000500
Closed	01037300000600
Closed	01037300000700
Closed	01037300000800
Closed	01037300000900
Closed	01037300001000
Closed	01036500002200
Closed	01036500002300
Closed	30063200300600
Closed	00510300003300
Closed	28062300101300
Closed	01036400002600
Closed	00426800001000
Closed	00585700007900
Closed	01036400000300
Closed	01036400000500
Closed	01036400000600
Closed	01036400000700
Closed	01036400000900
Closed	01036400001000
Closed	01036400001500
Closed	01036400001600
Closed	01036400002200
Closed	01036400002300
Closed	01036400002500
Closed	01036400002700
Closed	01036400002800
Closed	01037100000100
Closed	01037100000200
Closed	01037100000300
Closed	01037100000500
Closed	01037100000600
Closed	01037100000700

Accessory Dwelling Units

Index # - File Name: 1.0022 - Single Family Dwellings Data\_Snohomish County.pdf

Closed	01037100000800
Closed	01037100000900
Closed	01037100001000
Closed	01037100001100
Closed	01037100001200
Closed	01037100001300
Closed	01037100001400
Closed	01037100001500
Closed	01037100001700
Closed	01037100001800
Closed	31060600302100
Closed	01037300002000
Closed	01037300002100
Closed	01037300002200
Closed	01037300002300
Closed	01037300002400
Closed	00538000005702
Closed	00538000005702
Closed	00538000005702
Closed	00538000005702
Closed	01037900001000
Closed	01037900001100
Closed	01037900001600
Closed	32031300102100
Closed	00499100203600
Closed	01038800000100
Closed	01038800000200
Closed	01038800000300
Closed	01038800000400
Closed	01038800000500
Closed	01038800000600
Closed	01038800000700
Closed	01038800000800
Closed	01038800000900
Closed	01038800003400
Closed	01038800003500
Closed	01038800003600
Closed	01038800003700
Closed	01038800003800
Closed	01038800003900
Closed	01038800004000
Closed	01038800004100
Closed	01038800004200
Closed	01038800004300
Closed	01038800004400
Closed	01038800004500
Closed	01038800004600

Accessory Dwelling Units

Index # - File Name: 1.0022 - Single Family Dwellings Data\_Snohomish County.pdf

Closed	01038800004700
Closed	01038800004800
Closed	01038800004900
Closed	01038800005000
Closed	01038800005100
Closed	01038800005200
Closed	01038800006000
Closed	01038800006100
Closed	01038800006200
Closed	01038800006300
Closed	01038800006400
Closed	01038800006500
Closed	01038800006600
Closed	30061600400100
Closed	30061600400400
Closed	00585700008000
Closed	00512200005600
Closed	01038800007600
Closed	01038800007700
Closed	32081000201700
Closed	32081000201900
Closed	31051700102500
Closed	01038000001200
Closed	01039800002700
Closed	01039800002800
Closed	01039800002900
Closed	01039800002400
Closed	01039800002500
Closed	01039900000100
Closed	01039900000200
Closed	01039900000300
Closed	01039900000400
Closed	01039900000500
Closed	01039900000600
Closed	01039900001700
Closed	01039900001800
Closed	01039900001900
Closed	01039900002000
Closed	01039900001000
Closed	01039900001200
Closed	01039900001300
Closed	01039900001400
Closed	01039900003000
Closed	01039900004100
Closed	01039900003600
Closed	01039900003700
Closed	01039900003800

Accessory Dwelling Units

Index # - File Name: 1.0022 - Single Family Dwellings Data\_Snohomish County.pdf

Closed	01039900003900
Closed	32042600102500
Closed	32042300400800
Closed	01054100100201
Closed	01054100000301
Closed	00947600000100
Closed	00948600003000
Closed	00947600002100
Closed	00947600003300
Closed	00947600003600
Closed	00490000000700
Closed	28070600400600
Closed	28070600400700
Closed	30062400401800
Closed	28061800101200
Closed	27051100103700
Closed	29061100202900
Closed	00952300001700
Closed	00952300003700
Closed	00952300003800
Closed	00952300003900
Closed	00952300004000
Closed	00480000006000
Closed	00403900021803
Closed	00401100003600
Closed	30071900100900
Closed	00941400000300
Closed	29053600101900
Closed	00937500001600
Closed	00937500001800
Closed	00937500000200
Closed	00937500001100
Closed	00937100002000
Closed	00937100000700
Closed	00937100000800
Closed	00937000002100
Closed	00937000002200
Closed	00937000002300
Closed	00937000001400
Closed	00937000002500
Closed	00937000003000
Closed	00937000003100
Closed	00937000003200
Closed	00937000003300
Closed	00937000003400
Closed	00937000002800
Closed	00937000001600

Accessory Dwelling Units

Index # - File Name: 1.0022 - Single Family Dwellings Data\_Snohomish County.pdf

Closed	00937000001000
Closed	00937000000700
Closed	00937000000800
Closed	00937000000400
Closed	00937000004700
Closed	00937000004000
Closed	00937000004100
Closed	00937000004200
Closed	00937000003800
Closed	00937000001900
Closed	00937000002000
Closed	00937000003600
Closed	00935400001200
Closed	00935400001300
Closed	00937000000100
Closed	00937000000200
Closed	00934500002300
Closed	00934500002200
Closed	00935400000200
Closed	00934500003900
Closed	30050200401200
Closed	27061800403300
Closed	32062500301300
Closed	00934400001400
Closed	00934400001500
Closed	29062700302400
Closed	00933300002300
Closed	00933300001800
Closed	31041100202000
Closed	00401100003800
Closed	31041100201900
Closed	00955500000700
Closed	00955500000800
Closed	30060100301700
Closed	00955500000100
Closed	00955500000300
Closed	00955500000400
Closed	29052500201700
Closed	00954900000900
Closed	00954900000700
Closed	28063300101300
Closed	00954900001100
Closed	00954900001200
Closed	32040600200700
Closed	00952500000400
Closed	31042100304500
Closed	00376800004500

Accessory Dwelling Units

Index # - File Name: 1.0022 - Single Family Dwellings Data\_Snohomish County.pdf

Closed	0095800000100
Closed	0095800000200
Closed	0095800000300
Closed	0095800000400
Closed	0095800000500
Closed	0095800000600
Closed	0095800000700
Closed	00380900200702
Closed	28061400200600
Closed	0095800000900
Closed	0095800001000
Closed	0095800001100
Closed	0048700000100
Closed	30063400303300
Closed	00958700000600
Closed	00958700002500
Closed	00958700002600
Closed	00958700003400
Closed	00958700001800
Closed	00958700003800
Closed	00958700004800
Closed	00372800800808
Closed	29063200402000
Closed	29063200402100
Closed	00600700000200
Closed	00958800003700
Closed	00956600000300
Closed	00956600000300
Closed	00956600000400
Closed	00956600001100
Closed	00956600001700
Closed	27051500102000
Closed	01001700001800
Closed	01001700001900
Closed	01001700002000
Closed	01001700002100
Closed	01001700002200
Closed	01001700002300
Closed	00959200000100
Closed	00959200000200
Closed	00960010206200
Closed	01003700013300
Closed	01003700013400
Closed	01003700013500
Closed	01003700013600
Closed	01003700013700
Closed	01003700013800



Accessory Dwelling Units

Index # - File Name: 1.0022 - Single Family Dwellings Data\_Snohomish County.pdf

Closed	01003700013900
Closed	01003700014000
Closed	01003700014800
Closed	01003700014900
Closed	01003700015000
Closed	01003700015100
Closed	01003700015200
Closed	01003700015300
Closed	01003700015400
Closed	01003700015500
Closed	01003700005800
Closed	01003700005900
Closed	01003700006000
Closed	01003700005500
Closed	01003700005600
Closed	01003700003300
Closed	01003700002300
Closed	01003700002400
Closed	01003700002500
Closed	01003700002600
Closed	01003700004900
Closed	01003700000100
Closed	01003700000200
Closed	01003700000300
Closed	01003700000400
Closed	01003700000500
Closed	01003700000600
Closed	01003700000700
Closed	01003700000800
Closed	01003700000900
Closed	01003700001000
Closed	01003700001100
Closed	01003700001200
Closed	01003700001300
Closed	01003700001400
Closed	01003700001500
Closed	01003700001600
Closed	01003700001700
Closed	01003700001800
Closed	01003700001900
Closed	01003700002000
Closed	28072800303700
Closed	01001700001600
Closed	01003700014700
Closed	01002200000400
Closed	01000200002300
Closed	01003700006300

Accessory Dwelling Units

Index # - File Name: 1.0022 - Single Family Dwellings Data\_Snohomish County.pdf

Closed	01003700006400
Closed	01003700006500
Closed	01003700006600
Closed	01000400000400
Closed	01000400000800
Closed	01000400001000
Closed	28063200104800
Closed	01009800000400
Closed	01010100002300
Closed	28063200104500
Closed	28063200104600
Closed	00958000008800
Closed	00958000008900
Closed	00958000006200
Closed	00958000006300
Closed	00958000006400
Closed	00958000006500
Closed	00958000006600
Closed	00958000006700
Closed	00958000006800
Closed	00958000006900
Closed	00958000007000
Closed	00958000007100
Closed	00958000007200
Closed	00958000007300
Closed	00958000007400
Closed	00958000007500
Closed	00958000007600
Closed	00958000007700
Closed	00958000011600
Closed	00958000011700
Closed	00958000011800
Closed	00958000011900
Closed	00958000012000
Closed	00958000012100
Closed	00958000012200
Closed	01009800004200
Closed	01009800004300
Closed	01009800004400
Closed	01009800003900
Closed	01009800004000
Closed	01009800000600
Closed	01009800000700
Closed	01009800000800
Closed	01009800003100
Closed	01009800003200
Closed	01009800003300

Accessory Dwelling Units

Index # - File Name: 1.0022 - Single Family Dwellings Data\_Snohomish County.pdf

Closed	01009800003400
Closed	01009800003500
Closed	01009800003600
Closed	01009800001100
Closed	01009800001200
Closed	01009800001300
Closed	01009800001400
Closed	01009800001500
Closed	01009800001600
Closed	01009800001700
Closed	01009800001800
Closed	01009800001900
Closed	01009800000100
Closed	01009800000200
Closed	01008900002200
Closed	01008900002300
Closed	01008900000700
Closed	01009500001500
Closed	00394402503300
Closed	01008900003700
Closed	01008900002000
Closed	01008900000400
Closed	01009500000500
Closed	01009500000600
Closed	01009500000700
Closed	01009500000800
Closed	01009500000900
Closed	01009500001000
Closed	01009500001100
Closed	01009500001200
Closed	01009500001700
Closed	01009500001800
Closed	01009500001900
Closed	01009500002000
Closed	01009500002100
Closed	01009500002200
Closed	01009500002300
Closed	01009500002400
Closed	01009500002500
Closed	01009500002600
Closed	01009500002700
Closed	01009500002800
Closed	01009500002900
Closed	01009500003000
Closed	01009500003100
Closed	01009500003200
Closed	01009500003300

Accessory Dwelling Units

Index # - File Name: 1.0022 - Single Family Dwellings Data\_Snohomish County.pdf

Closed	01009500003400
Closed	30040800200400
Closed	01008300002500
Closed	01008300002600
Closed	01009200006000
Closed	01009200006100
Closed	01009200006200
Closed	01009200006300
Closed	01009200006400
Closed	01009200006500
Closed	01009200001400
Closed	01009200001500
Closed	01009200001600
Closed	01009200001700
Closed	01009200001800
Closed	01009200001900
Closed	01009200002000
Closed	01009200002100
Closed	01009200002200
Closed	01009200002300
Closed	01009200002400
Closed	01009200002500
Closed	01009200002600
Closed	01009200002700
Closed	01009200002800
Closed	01009200002900
Closed	01009200003000
Closed	01009200003100
Closed	01009200003200
Closed	27060500102000
Closed	28073200304100
Closed	30063000401200
Closed	01008300004800
Closed	01008300004900
Closed	01008300005000
Closed	01008300005100
Closed	01008300005200
Closed	01008300005300
Closed	01008300005400
Closed	01008300005500
Closed	01008300005600
Closed	01008300005700
Closed	01008300000700
Closed	01008300008000
Closed	01008300008100
Closed	01008300008200
Closed	01008300008300

Accessory Dwelling Units

Index # - File Name: 1.0022 - Single Family Dwellings Data\_Snohomish County.pdf

Closed	01008300008400
Closed	01008300008500
Closed	01008300008600
Closed	01008300008700
Closed	01008300008800
Closed	01008300008900
Closed	01008300009000
Closed	01008300009100
Closed	01008300009200
Closed	01008300009300
Closed	01008300009400
Closed	01008300009500
Closed	01008300009600
Closed	01008300009700
Closed	01008300009800
Closed	01008300009900
Closed	01008300010000
Closed	01008300010100
Closed	01008300010200
Closed	01008300010300
Closed	01008300010400
Closed	01008300010500
Closed	01008300010600
Closed	01008300010700
Closed	01008300003500
Closed	01008300003600
Closed	01008300003700
Closed	01008300003800
Closed	01008300003900
Closed	01008300004000
Closed	01008300004100
Closed	01008300004200
Closed	01008300004300
Closed	01008300004400
Closed	01008300004500
Closed	01008300001000
Closed	01008300001100
Closed	01008300001200
Closed	01008300001300
Closed	01008300001400
Closed	01008300001500
Closed	01008300001600
Closed	01008300001700
Closed	01008300001800
Closed	01008300001900
Closed	01008300002000
Closed	01008300002100

Accessory Dwelling Units

Index # - File Name: 1.0022 - Single Family Dwellings Data\_Snohomish County.pdf

Closed	01008300002200
Closed	01008300002300
Closed	01018600001400
Closed	01018600001500
Closed	01018600001600
Closed	01018600000200
Closed	01018600000300
Closed	01018600000400
Closed	01018600000500
Closed	01018600000600
Closed	01018600000700
Closed	01018600000800
Closed	01018600000900
Closed	01018600001000
Closed	01018600001100
Closed	01018600001200
Closed	00464200001500
Closed	01006700002000
Closed	01006900002400
Closed	01006900002500
Closed	01006900002600
Closed	01006900002000
Closed	00394400306500
Closed	01018600001800
Closed	01018600001900
Closed	01018600002000
Closed	01018600002100
Closed	01018600002300
Closed	01018600002400
Closed	01018600002500
Closed	01018600002600
Closed	01018600002800
Closed	01018600002900
Closed	01018600003000
Closed	01018600003200
Closed	01018600003300
Closed	01018600003400
Closed	01018600003700
Closed	01018600003800
Closed	01018600003900
Closed	01018600004000
Closed	01018600004100
Closed	01018600004200
Closed	01018600004300
Closed	01018600004400
Closed	01018600004500
Closed	01018600004600

Accessory Dwelling Units

Index # - File Name: 1.0022 - Single Family Dwellings Data\_Snohomish County.pdf

Closed	01018600004700
Closed	01018600004900
Closed	01018600005000
Closed	01018600005100
Closed	01018600005200
Closed	01018600005300
Closed	01018600005400
Closed	01018600005500
Closed	01018600005600
Closed	01018600005700
Closed	01018600005800
Closed	01002000000100
Closed	01002000000300
Closed	01002000000400
Closed	01002000000700
Closed	01002000000800
Closed	01002000001700
Closed	01004300001900
Closed	01004300002000
Closed	01004300001500
Closed	01004300001600
Closed	01004300001100
Closed	01004300001200
Closed	01004300000500
Closed	01004300000600
Closed	01004300000700
Closed	01004300000100
Closed	01004300000300
Closed	28060400101900
Closed	01004300004600
Closed	01004300004700
Closed	01004300004800
Closed	01004300003800
Closed	01004300003900
Closed	01004300005100
Closed	01004300005200
Closed	01004300003000
Closed	01004300002400
Closed	01004300002700
Closed	01004300004100
Closed	00526800000200
Closed	01011200000100
Closed	01011200000400
Closed	01004500001100
Closed	01004500001200
Closed	01004500001300
Closed	01004500001400

Accessory Dwelling Units

Index # - File Name: 1.0022 - Single Family Dwellings Data\_Snohomish County.pdf

Closed	01004500001700
Closed	01004500000100
Closed	01004500000200
Closed	01010500000300
Closed	01010500000400
Closed	01004800001900
Closed	01004800001100
Closed	01005200000600
Closed	01004800003500
Closed	01010500001700
Closed	01010500001800
Closed	01010500002000
Closed	01010500002100
Closed	01010500002400
Closed	01010500002500
Closed	01010500002600
Closed	01010500002700
Closed	01010500002800
Closed	01010500002900
Closed	01010500003000
Closed	01010500003100
Closed	01010500003300
Closed	01010500003400
Closed	01010500003500
Closed	01010500000700
Closed	01010500000800
Closed	01010500000900
Closed	01010500001000
Closed	01010500001100
Closed	01004800003200
Closed	01004800002400
Closed	01004800002600
Closed	01004800002800
Closed	01006900005300
Closed	01006900001500
Closed	01006700001600
Closed	01006700001700
Closed	01006700001800
Closed	01006700001400
Closed	01006700001000
Closed	01006700000800
Closed	01006700000600
Closed	01006700000300
Closed	01006700000100
Closed	30051500308300
Closed	01005200002400
Closed	01010500001500



Accessory Dwelling Units

Index # - File Name: 1.0022 - Single Family Dwellings Data\_Snohomish County.pdf

Closed	01005200001100
Closed	00372900800103
Closed	27052800208600
Closed	27052800208700
Closed	01043700000200
Closed	01043700000300
Closed	01043700000400
Closed	01047100001100
Closed	01047100001200
Closed	01047100001300
Closed	01047100001400
Closed	01047100001500
Closed	01047100001600
Closed	01047100001700
Closed	01047100001800
Closed	01047100001900
Closed	01047100002000
Closed	01047100002100
Closed	01043700000700
Closed	01043700000800
Closed	01043700000900
Closed	01043700001000
Closed	01043700001100
Closed	01043700001200
Closed	01043700001300
Closed	01043700002100
Closed	01043700002200
Closed	01043700002300
Closed	01043700002400
Closed	01044100000900
Closed	01043700001600
Closed	01043700001700
Closed	01043700001900
Closed	00394403800100
Closed	31062800300300
Closed	00464000100100
Closed	01047100003600
Closed	01047100003700
Closed	32053300301500
Closed	30063400400700
Closed	00489200000400
Closed	00489200000500
Closed	00489200000700
Closed	28072800303400
Closed	00401000005800
Closed	27060500102100
Closed	00511900100401

Accessory Dwelling Units

Index # - File Name: 1.0022 - Single Family Dwellings Data\_Snohomish County.pdf

Closed	00490100004000
Closed	00585200009000
Closed	01045900000400
Closed	01045900000500
Closed	01045900000600
Closed	32053200401900
Closed	00373002300606
Closed	00373002300504
Closed	00373002300503
Closed	00373002300502
Closed	00373002300501
Closed	01045900000200
Closed	01048000007600
Closed	01048000007700
Closed	01048000007800
Closed	01048000008700
Closed	01048000009000
Closed	01048000009400
Closed	01048000009500
Closed	01048000009600
Closed	01053000000400
Closed	01053000000500
Closed	01053000000600
Closed	01053000001000
Closed	01053000001800
Closed	01053000001900
Closed	29050200304800
Closed	29050200304900
Closed	00556600007900
Closed	31061900200400
Closed	01048200000100
Closed	01048200000500
Closed	01048200000600
Closed	01048200000800
Closed	01048200001300
Closed	01048200001400
Closed	01048200001700
Closed	01048200001800
Closed	01048200001900
Closed	01048200002000
Closed	01048200002100
Closed	01048200002200
Closed	28061300300400
Closed	28061300300400
Closed	00949300000101
Closed	00949300000201
Closed	00949300000301

Accessory Dwelling Units

Index # - File Name: 1.0022 - Single Family Dwellings Data\_Snohomish County.pdf

Closed	00949300000401
Closed	00949300000501
Closed	00949300000601
Closed	00949300000700
Closed	00949300000800
Closed	00949300000900
Closed	00949300001000
Closed	00949300001100
Closed	00949300001200
Closed	00949300001300
Closed	01056600000100
Closed	01056600000200
Closed	01056600000300
Closed	01056600000400
Closed	01056600000500
Closed	01056600000600
Closed	01056600000700
Closed	01056600000800
Closed	01056600000900
Closed	01056600001000
Closed	01056600001100
Closed	01056600001200
Closed	01056600001300
Closed	01056600001400
Closed	01056600001500
Closed	27051000302200
Closed	00464000301500
Closed	00464000301600
Closed	01046400000200
Closed	01046400000300
Closed	01046400000400
Closed	01046400000500
Closed	01046400000600
Closed	01046400000700
Closed	01046400000800
Closed	01046400000900
Closed	01046400001000
Closed	01046400001100
Closed	01046400001200
Closed	01046400001300
Closed	01046400001400
Closed	01050200000100
Closed	01050200000200
Closed	01050200000900
Closed	01050200001000
Closed	01050200001100
Closed	01050200001400

Accessory Dwelling Units

Index # - File Name: 1.0022 - Single Family Dwellings Data\_Snohomish County.pdf

Closed	01050200001500
Closed	01050200002100
Closed	01050200002200
Closed	01048700000600
Closed	01048700000700
Closed	01048700000800
Closed	01048700000900
Closed	01048700001000
Closed	01048700001100
Closed	01048700001200
Closed	01048700001500
Closed	01048700001600
Closed	01048700001700
Closed	01048700001800
Closed	01048700001900
Closed	01048700002000
Closed	01048700002100
Closed	01048700002200
Closed	01048700002300
Closed	01048700002400
Closed	01048700002500
Closed	01048700002600
Closed	01048700002700
Closed	01048700002800
Closed	01050200000700
Closed	00589500002900
Closed	29061300200700
Closed	00394403807700
Closed	30062100200900
Closed	01048700003000
Closed	01048700003100
Closed	01048700003200
Closed	01048700004500
Closed	01048700004600
Closed	01048700004700
Closed	01048700004800
Closed	01048700004900
Closed	00543300008100
Closed	01074000000100
Closed	01074000000200
Closed	01074000000300
Closed	01074000000400
Closed	01074000000500
Closed	01074000000600
Closed	01074000000700
Closed	01074000000800
Closed	01074000000900

Accessory Dwelling Units

Index # - File Name: 1.0022 - Single Family Dwellings Data\_Snohomish County.pdf

Closed	01074000001000
Closed	01074000001100
Closed	01074000001200
Closed	01074000001300
Closed	01074000001400
Closed	01074000001500
Closed	01074000001600
Closed	01074000001700
Closed	01074000001800
Closed	01074000001900
Closed	01074000002000
Closed	01074000002100
Closed	01074000002200
Closed	01074000002300
Closed	01074000002400
Closed	01074000002500
Closed	01074000002600
Closed	01074000002700
Closed	00478500001100
Closed	32041000403700
Closed	01048700000300
Closed	01048700000400
Closed	01048700004300
Closed	00520200006100
Closed	31042200100100
Closed	28060300405200
Closed	28061000101700
Closed	01054600000200
Closed	01054600000300
Closed	01054600000400
Closed	01054600001000
Closed	01054600001100
Closed	01054600001300
Closed	01054600001400
Closed	01054600001600
Closed	01060300001500
Closed	01060300001600
Closed	01060300001700
Closed	01060300001800
Closed	01060300001900
Closed	01060300002000
Closed	01060300002100
Closed	01060300002200
Closed	01060300002400
Closed	01060300002500
Closed	01060300002600
Closed	01060300002700

Accessory Dwelling Units

Index # - File Name: 1.0022 - Single Family Dwellings Data\_Snohomish County.pdf

Closed	01060300002800
Closed	01060300002900
Closed	01060300003000
Closed	01060300003100
Closed	01060300003200
Closed	01060300003300
Closed	01060300003400
Closed	00559900000200
Closed	01060300000100
Closed	01060300000200
Closed	01060300000300
Closed	01060300000400
Closed	01060300000500
Closed	01060300000600
Closed	01060300001100
Closed	01060300001200
Closed	01060300001300
Closed	00466100002800
Closed	32053000401300
Closed	32053000401300
Closed	01053400000500
Closed	01053400002300
Closed	00857800001301
Closed	00857800001302
Closed	00857800001303
Closed	00857800001304
Closed	32053300200500
Closed	31062900201600
Closed	00509200200704
Closed	00509200200705
Closed	00509200200706
Closed	00509200200707
Closed	00509200200708
Closed	00493300900509
Closed	00493300900510
Closed	31040900101500
Closed	31051700102600
Closed	29060400201800
Closed	30052200212200
Closed	30052200212300
Closed	30052200212400
Closed	30052200212500
Closed	30052200212600
Closed	30052200212700
Closed	30052200212800
Closed	30052200212900
Closed	30051600407300

Accessory Dwelling Units

Index # - File Name: 1.0022 - Single Family Dwellings Data\_Snohomish County.pdf

Closed	00538500001301
Closed	27050400200700
Closed	00538500001303
Closed	00538500001304
Closed	28073200304400
Closed	29050300108100
Closed	01049700002800
Closed	01049700002900
Closed	01049700003000
Closed	01049700003100
Closed	01049700003200
Closed	01049700003300
Closed	01049700003400
Closed	01049700003500
Closed	01049700003700
Closed	01049700003800
Closed	01049700003900
Closed	01049700004000
Closed	01049700004100
Closed	01049700004200
Closed	01049700004300
Closed	01049700005600
Closed	01049700005700
Closed	01049700005800
Closed	01049700004500
Closed	01049700004600
Closed	01049700011100
Closed	00373001000402
Closed	00373001000403
Closed	00373001000404
Closed	00373001000405
Closed	27080100200500
Closed	01068900000100
Closed	01068900003000
Closed	01068900003100
Closed	01068900003200
Closed	01058000000100
Closed	01058000000200
Closed	01058000000300
Closed	01058000000400
Closed	01058000000500
Closed	01058000000600
Closed	01058000000700
Closed	01058000000800
Closed	01058000000900
Closed	01058000001000
Closed	01058000001100

Accessory Dwelling Units

Index # - File Name: 1.0022 - Single Family Dwellings Data\_Snohomish County.pdf

Closed	01058000001200
Closed	01058000001300
Closed	01058000001400
Closed	01058000001500
Closed	01058000001600
Closed	01058000001700
Closed	01058000001800
Closed	01058000001900
Closed	01058000002000
Closed	01058000002200
Closed	01058000002300
Closed	01058000002400
Closed	01058000002500
Closed	01058000002600
Closed	01058000002700
Closed	01058000002800
Closed	01058000002900
Closed	01058000003000
Closed	01058000003100
Closed	01058000003200
Closed	01058000003300
Closed	01058000003400
Closed	01058000003500
Closed	01058000003600
Closed	01058000003700
Closed	01058000003800
Closed	01058000003900
Closed	01058000004000
Closed	01058000004100
Closed	01068900000700
Closed	01068900000800
Closed	01068900000900
Closed	01068900001000
Closed	01068900001100
Closed	01068900001200
Closed	01068900001300
Closed	01068900001400
Closed	01068900001500
Closed	01068900001600
Closed	01068900001700
Closed	01068900001800
Closed	01068900002500
Closed	01068900002600
Closed	01058000006400
Closed	01058000006500
Closed	01058000006600
Closed	01058000006700



Accessory Dwelling Units

Index # - File Name: 1.0022 - Single Family Dwellings Data\_Snohomish County.pdf

Closed	01058000006800
Closed	01058000006900
Closed	01058000007000
Closed	01058000007100
Closed	01058000007200
Closed	01058000007300
Closed	01058000007400
Closed	01058000007500
Closed	01058000007600
Closed	01058000007700
Closed	01058000008300
Closed	01058000008400
Closed	01058000008600
Closed	01058000008700
Closed	01058000008800
Closed	01058000008900
Closed	01058000009000
Closed	01058000009100
Closed	01058000009200
Closed	01058000009300
Closed	01058000009400
Closed	00557100400500
Closed	00512200007000
Closed	00533800002202
Closed	00373701600212
Closed	31040900202600
Closed	28062600302800
Closed	31060500203000
Closed	31060500203100
Closed	31060500203200
Closed	31060500203300
Closed	00373701600202
Closed	01050600000100
Closed	01050600000200
Closed	30050100100500
Closed	01052800000200
Closed	01052800000300
Closed	01052800000400
Closed	01052800000500
Closed	01052800000600
Closed	00577700600700
Closed	00466100003700
Closed	30040800400600
Closed	31041400400300
Closed	31041400400300
Closed	01052800001300
Closed	01052800001600

Accessory Dwelling Units

Index # - File Name: 1.0022 - Single Family Dwellings Data\_Snohomish County.pdf

Closed	01052800001700
Closed	01052800002900
Closed	01052800003000
Closed	01052800003100
Closed	01052800003200
Closed	01052800003300
Closed	01052800003500
Closed	01052600000400
Closed	01052800002100
Closed	01052800002300
Closed	01052800001900
Closed	00543800003300
Closed	01052700001500
Closed	01052700003000
Closed	01052700003100
Closed	01052700002800
Closed	01052700004500
Closed	00401000003400
Closed	27071100301400
Closed	01052700005000
Closed	01052700005100
Closed	01052700005200
Closed	01052700004700
Closed	01052700004800
Closed	01053300000100
Closed	01053300000200
Closed	01053300000300
Closed	01053300000400
Closed	01054000000300
Closed	01054000000400
Closed	01054000000500
Closed	01054000000600
Closed	27051100200300
Closed	00479901800901
Closed	00479901800100
Closed	31052400200500
Closed	31052400202000
Closed	00511900100401
Closed	00511900100500
Closed	00511900100500
Closed	01057200002300
Closed	01057200002900
Closed	01057200003000
Closed	01057200003100
Closed	01057200003200
Closed	01057200003300
Closed	01057200003400

Accessory Dwelling Units

Index # - File Name: 1.0022 - Single Family Dwellings Data\_Snohomish County.pdf

Closed	01057200003500
Closed	01057200003600
Closed	01057200002500
Closed	01057200005700
Closed	01054700000200
Closed	28073200304200
Closed	00490300001700
Closed	00551400002201
Closed	01054700003600
Closed	01054700003700
Closed	01054700003800
Closed	01054700003900
Closed	01054700004000
Closed	01054700004100
Closed	01054700004400
Closed	01059100001200
Closed	32041300301500
Closed	01075500001400
Closed	01075500002800
Closed	01058900000900
Closed	01075500002200
Closed	01055900000801
Closed	28050300404000
Closed	01058900000200
Closed	01058900000400
Closed	01058900000500
Closed	01058900000600
Closed	01058900002700
Closed	01055600000100
Closed	01055600000900
Closed	00394510300500
Closed	01059400000200
Closed	01059400000300
Closed	01059400000400
Closed	01059400000500
Closed	01059400000600
Closed	01055600000500
Closed	01056500000100
Closed	01056500000200
Closed	01056500000400
Closed	01056500000500
Closed	01056500000600
Closed	01056500000700
Closed	01056500000800
Closed	01056500000900
Closed	01056500001000
Closed	01056500001100

Accessory Dwelling Units

Index # - File Name: 1.0022 - Single Family Dwellings Data\_Snohomish County.pdf

Closed	00509200201601
Closed	00509200201602
Closed	31051600200900
Closed	27051100404800
Closed	28061700400800
Closed	01010500001600
Closed	29062000200900
Closed	27071800104700
Closed	30050100103400
Closed	01010500002200
Closed	01010500001300
Closed	01010500001400
Closed	01004300004200
Closed	01004300004300
Closed	01004300004400
Closed	01004300004500
Closed	01004300002800
Closed	01004300002900
Closed	01004300002500
Closed	01004300002600
Closed	01004300003100
Closed	01004300003200
Closed	01004300003300
Closed	01004300003400
Closed	01004300003500
Closed	01004300003600
Closed	01004300003700
Closed	01004300004000
Closed	01004300004900
Closed	01004300005000
Closed	01004300002100
Closed	01004300002200
Closed	01004300002300
Closed	28073500301300
Closed	31052600300300
Closed	01018600004800
Closed	01018600003100
Closed	01018600002700
Closed	01018600002200
Closed	01018600001300
Closed	01018600001700
Closed	01018600000100
Closed	00630600000600
Closed	31040500202700
Closed	01003700002100
Closed	01003700002200
Closed	01003700006100

Accessory Dwelling Units

Index # - File Name: 1.0022 - Single Family Dwellings Data\_Snohomish County.pdf

Closed	01003700006200
Closed	00959200000400
Closed	01001700000100
Closed	00960007610800
Closed	01001700001500
Closed	00956600002700
Closed	00956600002800
Closed	00956600001300
Closed	00956600001000
Closed	00958800003000
Closed	00958800002400
Closed	00958800002500
Closed	32051500301300
Closed	00958700004500
Closed	00513700005513
Closed	31051700102400
Closed	31042400100200
Closed	29060400103800
Closed	28053600400900
Closed	27051000201400
Closed	00955500000500
Closed	31040300201000
Closed	28062500407400
Closed	28082800203500
Closed	00934500004000
Closed	00935400000300
Closed	00937100001600
Closed	00935200001000
Closed	00937100002500
Closed	00937100002600
Closed	00403800010702
Closed	32060900401200
Closed	27063100400800
Closed	00372801400109
Closed	00935300000300
Closed	00574100005903
Closed	00948600001000
Closed	27063000305300
Closed	00950800000500
Closed	00950800000600
Closed	00950800000700
Closed	00950800000800
Closed	00379500000701
Closed	00480401707702
Closed	00480401707802
Closed	28060800102300
Closed	00557500001502

Accessory Dwelling Units

Index # - File Name: 1.0022 - Single Family Dwellings Data\_Snohomish County.pdf

Closed	01054100000401
Closed	01054100000601
Closed	01054100000701
Closed	01054100000800
Closed	01054100000901
Closed	01054100001001
Closed	01054100001201
Closed	01054100001301
Closed	01054100001501
Closed	27090800200900
Closed	01039900004000
Closed	01039900004200
Closed	01039900004300
Closed	01039900004400
Closed	01039900004500
Closed	00511900100603
Closed	00511900100601
Closed	00511900100601
Closed	01039900003100
Closed	01039900003200
Closed	01039900003300
Closed	01039900003400
Closed	01039900003500
Closed	01039900001600
Closed	01054100100101
Closed	01054100100201
Closed	01042600000200
Closed	01042600000400
Closed	01042600000500
Closed	01042600000600
Closed	01042600000700
Closed	01042600000800
Closed	01042600000900
Closed	01054400000600
Closed	01054400002300
Closed	01054400002700
Closed	01054400004000
Closed	01054400004100
Closed	01054400004200
Closed	01054400004300
Closed	01054400004400
Closed	00509000004105
Closed	00509000004106
Closed	00509000004108
Closed	01041300000100
Closed	01041300000200
Closed	01041300000300

Accessory Dwelling Units

Index # - File Name: 1.0022 - Single Family Dwellings Data\_Snohomish County.pdf

Closed	01041300000500
Closed	01041300000600
Closed	01041300000700
Closed	01041300000800
Closed	01041300000900
Closed	01041300001000
Closed	01041300001100
Closed	01041300001200
Closed	01041300001300
Closed	01041300001400
Closed	01041300001500
Closed	01041300001600
Closed	01041300001700
Closed	01041300001800
Closed	01041300001900
Closed	01041300002000
Closed	01041300002100
Closed	01041300003100
Closed	01041300003300
Closed	01041300003400
Closed	01041300003500
Closed	28061400402500
Closed	01041600000100
Closed	01041600000200
Closed	01041600000300
Closed	01041600000400
Closed	01041600000500
Closed	01041600000600
Closed	01041600000700
Closed	01041600000800
Closed	01041600000900
Closed	01041600001000
Closed	01041600001100
Closed	01041600001200
Closed	01041600001300
Closed	01041600001400
Closed	01041600001500
Closed	01041600001600
Closed	01041600001700
Closed	01041600001800
Closed	01041600001900
Closed	01041600002000
Closed	01041500000100
Closed	01041500000200
Closed	01041500000300
Closed	01041500000400
Closed	01041500000500

Accessory Dwelling Units

Index # - File Name: 1.0022 - Single Family Dwellings Data\_Snohomish County.pdf

Closed	01041500000600
Closed	01041500000700
Closed	01041500000800
Closed	01039900002100
Closed	01039900002200
Closed	01039900002300
Closed	01039900002400
Closed	01039900002500
Closed	01039900002600
Closed	01039900002700
Closed	01039900002800
Closed	01039900002900
Closed	01039900000800
Closed	01039900000900
Closed	01039800002600
Closed	01047800000400
Closed	31051700102200
Closed	01047800000700
Closed	01047800000800
Closed	01047800000900
Closed	01047800001000
Closed	00556600011700
Closed	01042100000100
Closed	01042100000200
Closed	01042100000300
Closed	01042100000400
Closed	01042100000500
Closed	01042100000600
Closed	01042100000700
Closed	01042100000800
Closed	01042100000900
Closed	01042100001000
Closed	01042100001100
Closed	01042100001200
Closed	01042100001300
Closed	01042100001400
Closed	01042100001500
Closed	01042100001600
Closed	01042100001700
Closed	01042100001800
Closed	01042100001900
Closed	01042100002000
Closed	01042100002100
Closed	01042100002200
Closed	01042100002300
Closed	01042100002400
Closed	01042100002500



Accessory Dwelling Units

Index # - File Name: 1.0022 - Single Family Dwellings Data\_Snohomish County.pdf

Closed	01042100002600
Closed	01042100002700
Closed	01042100002800
Closed	01042100002900
Closed	01042100003000
Closed	01042100003100
Closed	01042100003200
Closed	30070200400600
Closed	01066000000100
Closed	01066000000200
Closed	01066000000300
Closed	01066000000400
Closed	01066000000500
Closed	01066000000600
Closed	01066000000700
Closed	01066000000800
Closed	01066000000900
Closed	01041700004800
Closed	01041700004700
Closed	01041700004600
Closed	01041700004500
Closed	01041700004400
Closed	01041700004300
Closed	01041700001300
Closed	01041700001700
Closed	01039800000100
Closed	01039800000200
Closed	01039800000300
Closed	01039800000400
Closed	01039800000500
Closed	01039800000600
Closed	01039800000700
Closed	01039800000800
Closed	01039800000900
Closed	01039800001000
Closed	01039800001100
Closed	01039800001200
Closed	01039800001300
Closed	01039800001400
Closed	01039800001500
Closed	01039800001600
Closed	01039800001700
Closed	01039800001900
Closed	01039800002000
Closed	01039800002100
Closed	01039800002200
Closed	01039800002300

Accessory Dwelling Units

Index # - File Name: 1.0022 - Single Family Dwellings Data\_Snohomish County.pdf

Closed	01041700003900
Closed	01041700003700
Closed	01041700003600
Closed	01041700003500
Closed	01041700003400
Closed	32061800102000
Closed	00442900100110
Closed	00425500000501
Closed	00425500000502
Closed	00425500000503
Closed	00425500000504
Closed	00425500000505
Closed	00425500000506
Closed	00425500000507
Closed	00425500000508
Closed	01039400000100
Closed	01039400000200
Closed	01039400000300
Closed	01039400000400
Closed	01039400000500
Closed	01039400000600
Closed	01039400000700
Closed	01039400000800
Closed	01039400000900
Closed	01039400001000
Closed	01039400001100
Closed	01039400001200
Closed	01039400001300
Closed	01039400001400
Closed	01039400001500
Closed	01039400001600
Closed	01039400001700
Closed	01039400001800
Closed	01039400001900
Closed	01039400002000
Closed	01039400002100
Closed	01039400002200
Closed	00513700007220
Closed	01038000001300
Closed	01038000001400
Closed	01038000001500
Closed	01038000001600
Closed	01038000001700
Closed	01038000001800
Closed	01038000002000
Closed	01038000002100
Closed	01038000002200

Accessory Dwelling Units

Index # - File Name: 1.0022 - Single Family Dwellings Data\_Snohomish County.pdf

Closed	0103800002300
Closed	0103800002400
Closed	0103800002500
Closed	0103800002600
Closed	0103800002700
Closed	0103800002800
Closed	0103800002900
Closed	0103800003000
Closed	0103800001000
Closed	0103800001100
Closed	0103800003300
Closed	0103800003600
Closed	0103800004100
Closed	0103800004200
Closed	0103800004300
Closed	0103800004400
Closed	0103800004500
Closed	0103800004600
Closed	01048500004700
Closed	01048500004800
Closed	01048500004900
Closed	01048500005000
Closed	01048500005100
Closed	01048500005200
Closed	01048500005300
Closed	01048500005400
Closed	01048500005500
Closed	01048500005600
Closed	01048500005700
Closed	01048500005800
Closed	01048500005900
Closed	01048500006000
Closed	01048500006100
Closed	01048500006200
Closed	01048500006500
Closed	01048500006600
Closed	01048500006700
Closed	01048500006800
Closed	01048500006900
Closed	01038000000100
Closed	01038000000200
Closed	01038000000300
Closed	01038000000400
Closed	01038000000500
Closed	01038000000600
Closed	01038000000700
Closed	01038000005100

Accessory Dwelling Units

Index # - File Name: 1.0022 - Single Family Dwellings Data\_Snohomish County.pdf

Closed	29063400400400
Closed	29063500303100
Closed	01033200000100
Closed	01033200000200
Closed	01033200000300
Closed	01033200000400
Closed	01033200000500
Closed	01033200000600
Closed	01033200000700
Closed	01033200000800
Closed	01033200001000
Closed	01033200001100
Closed	01033200001200
Closed	01033200001300
Closed	01033200001400
Closed	01033200001500
Closed	01033200001600
Closed	01033200001700
Closed	01033200001800
Closed	01033200001900
Closed	01033200002000
Closed	01033200002300
Closed	01033200002400
Closed	01033200002500
Closed	01033200002600
Closed	01033200002700
Closed	01033200003000
Closed	01033200003100
Closed	01033200003200
Closed	01033200003300
Closed	01033200003400
Closed	01033200003500
Closed	01033200003600
Closed	01033200003700
Closed	01033200003800
Closed	01033200003900
Closed	01033200004000
Closed	01033200004100
Closed	01033200004200
Closed	01033200004300
Closed	01041700000100
Closed	00601600001601
Closed	01041700000200
Closed	01041700005400
Closed	01041700005300
Closed	01041700005200
Closed	01041700005100

Accessory Dwelling Units

Index # - File Name: 1.0022 - Single Family Dwellings Data\_Snohomish County.pdf

Closed	01041700001200
Closed	01041700001100
Closed	01041700001000
Closed	01041700001900
Closed	01041700004100
Closed	01041700004000
Closed	01041700003300
Closed	01041700003200
Closed	01041700003100
Closed	01041700003000
Closed	01041700002800
Closed	01041700002700
Closed	01041700002600
Closed	01041700002500
Closed	01041700002400
Closed	01041700002300
Closed	01041700002200
Closed	01041700002100
Closed	00460400000605
Closed	32081000202000
Closed	32081000201800
Closed	01048500000100
Closed	01048500000200
Closed	01048500000300
Closed	01048500000400
Closed	01048500000500
Closed	01048500000600
Closed	01048500000700
Closed	01048500000800
Closed	01048500000900
Closed	01048500001000
Closed	32081000201100
Closed	32081000201200
Closed	32081000201300
Closed	32081000201400
Closed	32081000202100
Closed	32081000201600
Closed	00585700007600
Closed	01037300002600
Closed	01037300002700
Closed	01037300002800
Closed	01037300002900
Closed	31050600102100
Closed	00491900300002
Closed	01048500001200
Closed	01048500001300
Closed	01048500001600

Accessory Dwelling Units

Index # - File Name: 1.0022 - Single Family Dwellings Data\_Snohomish County.pdf

Closed	01048500001800
Closed	01048500002000
Closed	01048500002200
Closed	01048500002600
Closed	01048500002700
Closed	01048500002800
Closed	01048500002900
Closed	01048500003000
Closed	01048500003100
Closed	01048500003200
Closed	01048500003300
Closed	01048500003400
Closed	01048500003500
Closed	01048500003600
Closed	01048500003700
Closed	01048500003800
Closed	01048500003900
Closed	01048500004000
Closed	01048500004100
Closed	01048500004200
Closed	01048500004300
Closed	01048500004400
Closed	01048500004500
Closed	01038800006900
Closed	01038800007000
Closed	01038800007100
Closed	01038800007200
Closed	01038800007300
Closed	01038800007400
Closed	01038800007500
Closed	01038800001000
Closed	01038800001100
Closed	01038800001200
Closed	01038800001300
Closed	01038800001400
Closed	01038800001500
Closed	01038800001600
Closed	01038800001700
Closed	01038800001800
Closed	01038800001900
Closed	01038800002000
Closed	01038800002100
Closed	01038800002200
Closed	01038800002300
Closed	01038800002400
Closed	01038800002500
Closed	01038800002600

Accessory Dwelling Units

Index # - File Name: 1.0022 - Single Family Dwellings Data\_Snohomish County.pdf

Closed	01038800002700
Closed	01038800002800
Closed	01038800002900
Closed	01038800003000
Closed	01038800003100
Closed	01038800003200
Closed	01038800003300
Closed	01041500001000
Closed	01041500001100
Closed	01041500001300
Closed	01041500001400
Closed	01041500001500
Closed	01041500001600
Closed	01041500001700
Closed	01041500001800
Closed	01041500001900
Closed	01041500002000
Closed	01041500002100
Closed	01041500002200
Closed	01041500002300
Closed	01041500002400
Closed	01041500002500
Closed	01041500002600
Closed	01041500002700
Closed	01041500002800
Closed	32063300203000
Closed	01054400003100
Closed	01041300002300
Closed	01041300002400
Closed	01041300002500
Closed	01041300002600
Closed	01041300002700
Closed	01041300002900
Closed	28061600400100
Closed	00556600013600
Closed	28050300402600
Closed	01043600001100
Closed	01043600001200
Closed	01043600001300
Closed	01043600001400
Closed	01043600001500
Closed	01043600001600
Closed	01043600001700
Closed	01043600001800
Closed	01043600001900
Closed	01043600002000
Closed	01043600002100

Accessory Dwelling Units

Index # - File Name: 1.0022 - Single Family Dwellings Data\_Snohomish County.pdf

Closed	01043600002200
Closed	01043600002300
Closed	01043600002400
Closed	01043600002500
Closed	01043600002600
Closed	01043600002700
Closed	01043600002800
Closed	01043600002900
Closed	01043600003000
Closed	01043600003100
Closed	01043600003200
Closed	01043600003300
Closed	01043600003400
Closed	01043600003600
Closed	01043600003700
Closed	01043600003800
Closed	01043600003900
Closed	01043600004000
Closed	01043600004100
Closed	01043600004200
Closed	01043600004300
Closed	01043600004400
Closed	01043600004500
Closed	01043600004600
Closed	01043600004700
Closed	01043600004800
Closed	28050300400600
Closed	01043600005700
Closed	01043600005800
Closed	01043600005900
Closed	01043600006000
Closed	01043600006100
Closed	01043600006200
Closed	01043600006300
Closed	01043600006400
Closed	01041700001400
Closed	01041700001500
Closed	01041700001600
Closed	28093100401800
Closed	01042000000100
Closed	01042000000200
Closed	01042000000300
Closed	01042000000400
Closed	01042000000500
Closed	01042000000600
Closed	01042000000700
Closed	01042000000800



Accessory Dwelling Units

Index # - File Name: 1.0022 - Single Family Dwellings Data\_Snohomish County.pdf

Closed	0104200000900
Closed	0104200001000
Closed	0104200001100
Closed	0104200001200
Closed	0104360000500
Closed	01043600005100
Closed	01043600005200
Closed	01043600005300
Closed	01043600005400
Closed	01043600005500
Closed	00374100100707
Closed	00374100100708
Closed	29062300400800
Closed	29062300400800
Closed	28072300200500
Closed	32071200101900
Closed	01042000007000
Closed	01042000007100
Closed	01042000007200
Closed	01042000007300
Closed	01042000008000
Closed	01042000008100
Closed	01042000008200
Closed	01042000008300
Closed	01042000008400
Closed	01042000008500
Closed	01042000008600
Closed	01042000008900
Closed	01042000009000
Closed	01042000009100
Closed	01042000009200
Closed	01042000007800
Closed	01042000009900
Closed	01042000010200
Closed	29062500400700
Closed	01043900000100
Closed	01043900000200
Closed	01043900000300
Closed	01043900000400
Closed	01043900000500
Closed	01043900000600
Closed	01043900000700
Closed	01043900000800
Closed	01043900000900
Closed	01043900001000
Closed	01043900001100
Closed	01039700000100

Accessory Dwelling Units

Index # - File Name: 1.0022 - Single Family Dwellings Data\_Snohomish County.pdf

Closed	01039700000200
Closed	01039700000300
Closed	01039700000400
Closed	01039700000500
Closed	01039700000600
Closed	01039700000700
Closed	01039700000800
Closed	01039700000900
Closed	01039700001000
Closed	01039700001100
Closed	01039700001200
Closed	01039700001300
Closed	01039700001400
Closed	01042500000100
Closed	01042500000200
Closed	01042500000300
Closed	01042500001200
Closed	01042500001300
Closed	01042500001400
Closed	01042500001500
Closed	01042500001600
Closed	01042500001700
Closed	01042500001800
Closed	01042500001900
Closed	01042500002000
Closed	01042500002100
Closed	01042500002200
Closed	01042500002300
Closed	01042500002400
Closed	01042500002500
Closed	01042500002600
Closed	01042500002700
Closed	01042500002800
Closed	01042500002900
Closed	01042500003000
Closed	01042500003100
Closed	01042500003200
Closed	01042500003300
Closed	01042500003400
Closed	01042500003500
Closed	01042500003600
Closed	01042500003700
Closed	01042500003800
Closed	01042500003900
Closed	01042500004000
Closed	01042500004100
Closed	01042500004200

Accessory Dwelling Units

Index # - File Name: 1.0022 - Single Family Dwellings Data\_Snohomish County.pdf

Closed	0104250000600
Closed	0104250000700
Closed	0104250000900
Closed	0104250001000
Closed	0104250004500
Closed	0104250004600
Closed	0104250004700
Closed	0104250005000
Closed	0104250005100
Closed	0104250005200
Closed	0104250005400
Closed	0104250005500
Closed	0104250005700
Closed	0104250005800
Closed	0104250005900
Closed	0104250006000
Closed	0104250007600
Closed	0104250007700
Closed	0104250007800
Closed	0104250007900
Closed	0104250008000
Closed	0104250008100
Closed	0104250008200
Closed	0104250008300
Closed	0104250008400
Closed	0104250008500
Closed	0104250008600
Closed	0104250008700
Closed	27051500404600
Closed	30060600402600
Closed	0104600000100
Closed	0104250006200
Closed	0104250006300
Closed	0104250006400
Closed	0104250006500
Closed	0104250006600
Closed	0104250006700
Closed	0104250006800
Closed	0104250006900
Closed	0104250007000
Closed	0104250007100
Closed	0104600001100
Closed	0104600001200
Closed	0104290001200
Closed	0104290001300
Closed	0104290001400
Closed	0104290001500

Accessory Dwelling Units

Index # - File Name: 1.0022 - Single Family Dwellings Data\_Snohomish County.pdf

Closed	01042900001600
Closed	01042900001700
Closed	01042900001800
Closed	01042900001900
Closed	01042900002000
Closed	01042900002100
Closed	01042900002200
Closed	01042900002300
Closed	01042900002500
Closed	01042900002600
Closed	01042900002700
Closed	01046000002100
Closed	00373100601701
Closed	01042900000100
Closed	01042900000200
Closed	01042900000300
Closed	01042900000400
Closed	01042900000500
Closed	01042900000600
Closed	01042900000700
Closed	01042900000800
Closed	01042900000900
Closed	01042900001000
Closed	01046000000600
Closed	01046000000300
Closed	01046000000400
Closed	01043800102100
Closed	01043800104300
Closed	01043800200100
Closed	01043800200200
Closed	01043800201200
Closed	01043800201300
Closed	01043800201400
Closed	01043800201500
Closed	01043800201700
Closed	01043800201800
Closed	01043800201900
Closed	01043800202000
Closed	01043800202100
Closed	01043800202200
Closed	01043800202300
Closed	01043800200500
Closed	01043800200600
Closed	01043800200700
Closed	01043800200800
Closed	01043800200900
Closed	01043800201000

Accessory Dwelling Units

Index # - File Name: 1.0022 - Single Family Dwellings Data\_Snohomish County.pdf

Closed	01043800202500
Closed	01043800202600
Closed	01043800202700
Closed	01042900003100
Closed	01042900003200
Closed	01042900003300
Closed	01042900003400
Closed	01042900003500
Closed	01042900003600
Closed	01042900003700
Closed	01042900005200
Closed	01042900005300
Closed	01042900005400
Closed	01042900005500
Closed	01042900005600
Closed	01042900005700
Closed	01042900005800
Closed	01042900006000
Closed	01042900006100
Closed	01042900006200
Closed	01042900006300
Closed	01042900006400
Closed	01042900006500
Closed	01042900006600
Closed	01042900006700
Closed	01042900006800
Closed	01042900006900
Closed	01042900007000
Closed	01042900004200
Closed	01042900004400
Closed	01042900004500
Closed	01042900004600
Closed	01042900004700
Closed	01042900004800
Closed	01042900004900
Closed	01042900005000
Closed	01043300000100
Closed	01043300000300
Closed	01043300000400
Closed	01043300000500
Closed	01043300000600
Closed	01043300000700
Closed	01043300000800
Closed	01043300000900
Closed	01043300001000
Closed	01043300001100
Closed	01043300001200

Accessory Dwelling Units

Index # - File Name: 1.0022 - Single Family Dwellings Data\_Snohomish County.pdf

Closed	27062800103800
Closed	27062800103900
Closed	30060600401700
Closed	01043300001300
Closed	01043300001400
Closed	01043300001500
Closed	01043300001600
Closed	01043300001700
Closed	01043300001800
Closed	01042900002800
Closed	01042900002900
Closed	01042900003900
Closed	01042900004000
Closed	01043500001100
Closed	01043500001200
Closed	01043500001300
Closed	01043500001400
Closed	01043500001500
Closed	01043500001600
Closed	01043500001700
Closed	01043300001900
Closed	01043500002000
Closed	01043500002100
Closed	01043500002300
Closed	01044800000100
Closed	01044800000200
Closed	01044800000300
Closed	01044800000400
Closed	01044800000500
Closed	01044800000600
Closed	01044800000700
Closed	01044800000800
Closed	01044800000900
Closed	01044800001000
Closed	01044800001100
Closed	01044800001200
Closed	01044800001300
Closed	01044800001400
Closed	01044800001500
Closed	01044800001600
Closed	01043300002000
Closed	01043300002100
Closed	01043300002200
Closed	01043300002300
Closed	01043300002400
Closed	01044800001900
Closed	01044800002400

Accessory Dwelling Units

Index # - File Name: 1.0022 - Single Family Dwellings Data\_Snohomish County.pdf

Closed	01044800002500
Closed	01044800002600
Closed	01044800002700
Closed	01044800002800
Closed	01044800002900
Closed	01044800003000
Closed	01044800003100
Closed	01044800003200
Closed	01044800003300
Closed	01044800003400
Closed	01044800003500
Closed	01044800003600
Closed	01046800001200
Closed	01046800001300
Closed	01046800001400
Closed	01046800001500
Closed	01046800001600
Closed	01046800001700
Closed	01046800001800
Closed	01046800001900
Closed	01046800002000
Closed	01046800002100
Closed	01046800002400
Closed	01046800002500
Closed	01046800002600
Closed	01046800002700
Closed	01046800002800
Closed	01046800002900
Closed	01046800003000
Closed	01046800003100
Closed	01046800003200
Closed	01046800003300
Closed	01046800003400
Closed	01046800003500
Closed	01046800003600
Closed	01046800003700
Closed	01046800003900
Closed	01046800004000
Closed	01046800004100
Closed	01046800004200
Closed	01046800004300
Closed	01046800004400
Closed	32052200400100
Closed	01046800000400
Closed	01046800000500
Closed	01046800000600
Closed	01046800000700

Accessory Dwelling Units

Index # - File Name: 1.0022 - Single Family Dwellings Data\_Snohomish County.pdf

Closed	01046800000900
Closed	01046800001000
Closed	28060800302500
Closed	01047100000100
Closed	01047100000200
Closed	01047100000300
Closed	01047100000400
Closed	01047100000500
Closed	01047100000600
Closed	01047100000700
Closed	01047100000800
Closed	01047100000900
Closed	01047100002500
Closed	01047100002600
Closed	01047100002700
Closed	01047100002800
Closed	01047100002900
Closed	01047100003000
Closed	01047100003100
Closed	01047100003200
Closed	01047100003300
Closed	01047100003400
Closed	01047100003500
Closed	01044000000100
Closed	01044000000200
Closed	01044000000300
Closed	01044000000400
Closed	01044000000500
Closed	01044000000600
Closed	01044000000700
Closed	01044000000800
Closed	01044000000900
Closed	01044000001000
Closed	01044100000100
Closed	01044100000300
Closed	01044100000400
Closed	01044100000500
Closed	01044100000600
Closed	01037900001700
Closed	01037900001800
Closed	01037900001900
Closed	01037900002000
Closed	01037900002100
Closed	01037900002200
Closed	01037900002300
Closed	01037900002400
Closed	01037900001200



Accessory Dwelling Units

Index # - File Name: 1.0022 - Single Family Dwellings Data\_Snohomish County.pdf

Closed	01037900001300
Closed	01037900001400
Closed	01037900001500
Closed	01040500003300
Closed	01040500003400
Closed	01040500003800
Closed	01040500003900
Closed	01040500004000
Closed	28060300303200
Closed	01037900000200
Closed	01037900000300
Closed	01037900000400
Closed	01037900000500
Closed	01037900000600
Closed	01037900000700
Closed	01037900000800
Closed	01037900000900
Closed	00373700601506
Closed	01040500002700
Closed	01040500003000
Closed	01037300002500
Closed	01036500000900
Closed	01036500001000
Closed	01040500000700
Closed	01040500000800
Closed	01040500000900
Closed	01040500000400
Closed	01040500000500
Closed	01040500001100
Closed	01040500001600
Closed	01040500001700
Closed	01040500001800
Closed	01040500001900
Closed	01040500002000
Closed	01040500002100
Closed	01040500002200
Closed	01037100000400
Closed	28050200302000
Closed	27052800208300
Closed	27052800208400
Closed	01036500002400
Closed	01036500002500
Closed	01036500002600
Closed	00373003100110
Closed	00373003100111
Closed	00373003100112
Closed	01037300001100

Accessory Dwelling Units

Index # - File Name: 1.0022 - Single Family Dwellings Data\_Snohomish County.pdf

Closed	01037300001200
Closed	01037300001300
Closed	01037300001400
Closed	01037300001500
Closed	01037300001600
Closed	01037300001700
Closed	01037300001800
Closed	01037300001900
Closed	01036500001900
Closed	01036500002000
Closed	01036500002100
Closed	01036500001200
Closed	01036500001300
Closed	01036500001400
Closed	01036500001500
Closed	01036500001600
Closed	01036500001700
Closed	01036500000700
Closed	01035800001700
Closed	01036500000200
Closed	01036500000300
Closed	01036500000400
Closed	01035800002800
Closed	01035800002900
Closed	01035800003000
Closed	01035800001400
Closed	01035800001100
Closed	01039600000100
Closed	00373300400711
Closed	01035800000100
Closed	01035800000200
Closed	01035800000300
Closed	01035800000400
Closed	01035800000500
Closed	01035800000600
Closed	01035800000700
Closed	01035800000800
Closed	01035800000900
Closed	01067000000600
Closed	01049500002200
Closed	01049500002300
Closed	01049500002400
Closed	01049500002500
Closed	01049500002600
Closed	01049500002700
Closed	01049500002800
Closed	01049500002900

Accessory Dwelling Units

Index # - File Name: 1.0022 - Single Family Dwellings Data\_Snohomish County.pdf

Closed	01049500003000
Closed	01049500003100
Closed	01049500003200
Closed	01049500003400
Closed	01049500003500
Closed	01049500003600
Closed	01049500003800
Closed	01049500004000
Closed	01049500004100
Closed	01049500004200
Closed	01049500004300
Closed	01049500004400
Closed	01049500004500
Closed	01049500004600
Closed	01049500004700
Closed	01049500004800
Closed	01049500004900
Closed	01049500005000
Closed	01049500005100
Closed	00600500000700
Closed	29061100203000
Closed	01039600000300
Closed	01039600000400
Closed	01039600000500
Closed	01039600000600
Closed	01039600000700
Closed	01039600000800
Closed	01039600000900
Closed	01039600001000
Closed	01039600001100
Closed	01039600001200
Closed	01039600001300
Closed	01039600001400
Closed	01039600001500
Closed	01039600001600
Closed	01039600001700
Closed	01039600001800
Closed	01039600001900
Closed	01039600002000
Closed	01039600002100
Closed	00440300000301
Closed	00440300000400
Closed	28073600200100
Closed	00373300600705
Closed	01049500000100
Closed	01049500000200
Closed	01049500000300

Accessory Dwelling Units

Index # - File Name: 1.0022 - Single Family Dwellings Data\_Snohomish County.pdf

Closed	01049500000400
Closed	01049500000500
Closed	01049500000600
Closed	01049500000700
Closed	01049500000800
Closed	01049500000900
Closed	01049500001000
Closed	01049500001100
Closed	01049500001200
Closed	01049500001300
Closed	01049500001400
Closed	01049500001500
Closed	01049500001600
Closed	01049500001700
Closed	01049500001800
Closed	01049500001900
Closed	01049500002000
Closed	27063400100800
Closed	32062000100600
Closed	29070500102100
Closed	30050600101500
Closed	32040400301400
Closed	00396500001600
Closed	00600500000600
Closed	30073200402500
Closed	29070500101900
Closed	01039100003300
Closed	01039100003400
Closed	01039100002900
Closed	01039100003000
Closed	01039100003100
Closed	27060500102300
Closed	32040900300700
Closed	01039100002300
Closed	01039100002100
Closed	01039100001800
Closed	01039100001900
Closed	01039100001500
Closed	01039100001600
Closed	01039100001200
Closed	01039100001300
Closed	01039100000700
Closed	01035300003100
Closed	01039100000100
Closed	01039100000200
Closed	01039100000300
Closed	01039100000400

Accessory Dwelling Units

Index # - File Name: 1.0022 - Single Family Dwellings Data\_Snohomish County.pdf

Closed	01039100000500
Closed	01035300002500
Closed	01035300002600
Closed	01035300002700
Closed	00373700801501
Closed	01035300002100
Closed	01035300002200
Closed	01035300002300
Closed	29060200403200
Closed	01035300001300
Closed	01035300001400
Closed	01035300000200
Closed	01035300000300
Closed	01035300000400
Closed	01035300000500
Closed	01035300000600
Closed	01035300000700
Closed	01035300000800
Closed	01035300000900
Closed	01035300001000
Closed	01035300001100
Closed	32041300301400
Closed	00394402404200
Closed	01033100003300
Closed	01033700002700
Closed	01033700002800
Closed	01033700002900
Closed	31051700103200
Closed	01033700001100
Closed	01034100003100
Closed	01033700002400
Closed	01033700002500
Closed	01033700000900
Closed	01033100001500
Closed	01033100001600
Closed	01033100001700
Closed	01033100001800
Closed	01033100001900
Closed	01033100002000
Closed	01033100002100
Closed	01033100002200
Closed	01033100002300
Closed	01033100002400
Closed	01033100002500
Closed	01033100002600
Closed	01033100002700
Closed	01034100004700

Accessory Dwelling Units

Index # - File Name: 1.0022 - Single Family Dwellings Data\_Snohomish County.pdf

Closed	01034100004800
Closed	01034100002500
Closed	01034100002700
Closed	01034100002900
Closed	01034100004300
Closed	01034100004400
Closed	01034100004500
Closed	01034500003600
Closed	01034500003700
Closed	00490100007100
Closed	01034100001400
Closed	01034100001700
Closed	01034800002800
Closed	01034800002900
Closed	01034800003000
Closed	01034800003100
Closed	01034800003200
Closed	01034800003300
Closed	01034800003400
Closed	01034800003600
Closed	01034500003900
Closed	01034500004000
Closed	01034500003200
Closed	01034500003300
Closed	01034500003400
Closed	01034800002400
Closed	01033600007400
Closed	01033600007500
Closed	01033600002100
Closed	01033600002200
Closed	01033600002300
Closed	01033600002400
Closed	01033600002500
Closed	01033600002600
Closed	01033600002700
Closed	01033600002800
Closed	01033600002900
Closed	01033600003000
Closed	01033600003100
Closed	01034500002400
Closed	01034500002500
Closed	01034500002600
Closed	01034500002700
Closed	01034500002800
Closed	01034500002900
Closed	01034500003000
Closed	01034500001300

Accessory Dwelling Units

Index # - File Name: 1.0022 - Single Family Dwellings Data\_Snohomish County.pdf

Closed	01034500001400
Closed	01034500001500
Closed	01034500001600
Closed	01034500001700
Closed	01034500001800
Closed	01034500000100
Closed	01034500000200
Closed	32042600202200
Closed	01034500002100
Closed	01034500000600
Closed	01034500000700
Closed	01034500000800
Closed	01034500000900
Closed	01034500001000
Closed	01034500001100
Closed	01045000000100
Closed	01045000000200
Closed	01045000000300
Closed	01045000000400
Closed	01045000000500
Closed	01045000000600
Closed	01045000000700
Closed	01045000000800
Closed	01045000000900
Closed	01045000001000
Closed	01045000001100
Closed	01045000001200
Closed	01045000001300
Closed	01045000001400
Closed	01045000001500
Closed	01045000001600
Closed	01045000001700
Closed	01045000001800
Closed	01045000001900
Closed	01045000002000
Closed	01045000002100
Closed	01045000002200
Closed	01045000002300
Closed	01045000002400
Closed	01045000002500
Closed	00394509401300
Closed	01031900002700
Closed	01031900002800
Closed	00374800003502
Closed	00374800003503
Closed	01030100001400
Closed	01030100000100

Accessory Dwelling Units

Index # - File Name: 1.0022 - Single Family Dwellings Data\_Snohomish County.pdf

Closed	01031900008000
Closed	01031900004100
Closed	01031900004900
Closed	01031900007400
Closed	01031900003000
Closed	01031900003100
Closed	01031900003400
Closed	01040300000500
Closed	01029100001900
Closed	01029100000600
Closed	01031900001400
Closed	01031900001500
Closed	01031900001600
Closed	01031900001700
Closed	01031900001800
Closed	01031900001900
Closed	01031900002000
Closed	01031900002100
Closed	01031900002200
Closed	01031900002300
Closed	01031900002400
Closed	01031900002500
Closed	31051700301500
Closed	01029800002300
Closed	01029800002400
Closed	01029800002500
Closed	01029100001500
Closed	01029300007400
Closed	00473300001629
Closed	01023800004600
Closed	01029100000100
Closed	01029000002400
Closed	01028700001100
Closed	01028700001200
Closed	01029000000200
Closed	01028700000400
Closed	01029300006700
Closed	01029300006800
Closed	01029300006900
Closed	01029300006000
Closed	01029300006100
Closed	01029300005400
Closed	01029300005500
Closed	01028600001700
Closed	01029300005200
Closed	01028600001500
Closed	01029200000100



Accessory Dwelling Units

Index # - File Name: 1.0022 - Single Family Dwellings Data\_Snohomish County.pdf

Closed	01029300004500
Closed	01029300003600
Closed	01029300001500
Closed	01029300001600
Closed	01029300001700
Closed	01028600002400
Closed	01028600002500
Closed	01028600002600
Closed	01028600002700
Closed	30060200303000
Closed	30060200304500
Closed	01029300000700
Closed	01029300000800
Closed	01029300000900
Closed	01028600001100
Closed	01029200000500
Closed	01029200000600
Closed	01029200000700
Closed	32052200102600
Closed	01027300005500
Closed	28061300400600
Closed	01025000002000
Closed	01025000002100
Closed	01025000002200
Closed	01025000002400
Closed	01025000002500
Closed	01025000002600
Closed	01025000002700
Closed	01025000002800
Closed	01025000002900
Closed	01010100003400
Closed	01010100004500
Closed	01011100002400
Closed	01011800000400
Closed	01011800000500
Closed	01010700000900
Closed	01011800001000
Closed	01011800001100
Closed	01011800000700
Closed	01011800001300
Closed	01011500001900
Closed	01011500002000
Closed	01013100000200
Closed	01013100000300
Closed	01013100000400
Closed	01013100000500
Closed	01013100000600

Accessory Dwelling Units

Index # - File Name: 1.0022 - Single Family Dwellings Data\_Snohomish County.pdf

Closed	01013100001300
Closed	01013100001400
Closed	01013100001500
Closed	01013100001600
Closed	30061700402300
Closed	30061700402600
Closed	30061700402700
Closed	30061700403000
Closed	28073300203600
Closed	28050300303600
Closed	01017000002900
Closed	01017000003000
Closed	01017000003100
Closed	01017000000900
Closed	01017000000100
Closed	01017000000200
Closed	01017000003400
Closed	01017000003500
Closed	01017000003600
Closed	01021500000500
Closed	01021500000700
Closed	01021500000800
Closed	01021500000900
Closed	01021500003300
Closed	01021500003400
Closed	01021500001100
Closed	01021500001200
Closed	01021500001300
Closed	01021500001400
Closed	01021500001600
Closed	01021500001700
Closed	01017000003200
Closed	01017000003300
Closed	01022400000100
Closed	01022400000200
Closed	01022400000300
Closed	01022400000400
Closed	01022400000500
Closed	01022400000600
Closed	01022400000700
Closed	01022400000800
Closed	01022400000900
Closed	01022400001000
Closed	01022400001100
Closed	01022400001200
Closed	01022400001300
Closed	01022400001400

Accessory Dwelling Units

Index # - File Name: 1.0022 - Single Family Dwellings Data\_Snohomish County.pdf

Closed	01022400001500
Closed	01022400001600
Closed	01022400001700
Closed	01022400001800
Closed	01022400001900
Closed	01022400002000
Closed	01022400002100
Closed	01022400002200
Closed	01022400002300
Closed	01022400002400
Closed	01022400002500
Closed	01022400002600
Closed	01022400002700
Closed	01022400002800
Closed	01022400002900
Closed	01022400003000
Closed	01022400003100
Closed	01022400003200
Closed	01022400003300
Closed	01022400003400
Closed	01022400003500
Closed	01022400003600
Closed	01022400003700
Closed	01022400003800
Closed	01022400003900
Closed	01022400004000
Closed	01022400004100
Closed	01022400004200
Closed	01022400004300
Closed	01022400004400
Closed	01022400004500
Closed	01022400004600
Closed	01022400004700
Closed	01022400004800
Closed	01022400004900
Closed	01022400005000
Closed	01022400005100
Closed	01022400005200
Closed	01022400005300
Closed	01022400005400
Closed	01022400005500
Closed	01022400005600
Closed	01022400005700
Closed	01021500003900
Closed	01021500004000
Closed	01021500004100
Closed	01021500004200

Accessory Dwelling Units

Index # - File Name: 1.0022 - Single Family Dwellings Data\_Snohomish County.pdf

Closed	01021500004300
Closed	01021500004400
Closed	01021500004500
Closed	01021500004600
Closed	01021500004700
Closed	01021500004800
Closed	01021500004900
Closed	01021500005000
Closed	31051200402400
Closed	01019500003200
Closed	01027300004700
Closed	01027100000100
Closed	01027100000200
Closed	01027100000300
Closed	01027100000400
Closed	01026800004300
Closed	01026800004400
Closed	00574100006300
Closed	01024800001700
Closed	01025000000800
Closed	01025000000900
Closed	01025000001000
Closed	01025000001100
Closed	01025000001200
Closed	01024800002200
Closed	01024800000900
Closed	01024800001500
Closed	01024300002600
Closed	01024800000400
Closed	01024800000500
Closed	01024300005600
Closed	01024300005700
Closed	01024300005800
Closed	01024300005900
Closed	01024300006000
Closed	01024300004800
Closed	01024300004900
Closed	01024300003200
Closed	01024300003300
Closed	01024300003400
Closed	01024300003500
Closed	01024300003600
Closed	01024300002400
Closed	01024300000700
Closed	01024300002100
Closed	01024300002200
Closed	01024300001100

Accessory Dwelling Units

Index # - File Name: 1.0022 - Single Family Dwellings Data\_Snohomish County.pdf

Closed	01024300001200
Closed	01024300001300
Closed	01024300001400
Closed	01024300001500
Closed	01024300001600
Closed	01024300000100
Closed	01024300000200
Closed	01024300000300
Closed	01024300000400
Closed	01024300000500
Closed	01026900106400
Closed	29062100101400
Closed	01026900103300
Closed	27051100305900
Closed	01026900200100
Closed	01026900200200
Closed	01026900200300
Closed	01026900200400
Closed	01026900200500
Closed	01026900200600
Closed	01026900200700
Closed	01026900200800
Closed	01026900200900
Closed	01026900201000
Closed	01026900201100
Closed	01026900201200
Closed	01026900201300
Closed	01026900201400
Closed	01026900201500
Closed	01026900201600
Closed	01026900201700
Closed	01026900106100
Closed	01026900102200
Closed	01026900102300
Closed	01023800004300
Closed	01023800003600
Closed	01023800003000
Closed	01023800003100
Closed	01023800003200
Closed	01023800003300
Closed	01023800003400
Closed	01019400005900
Closed	01019400006000
Closed	01019400006100
Closed	01019400006200
Closed	01019100002000
Closed	01019100002100

Accessory Dwelling Units

Index # - File Name: 1.0022 - Single Family Dwellings Data\_Snohomish County.pdf

Closed	01019100002200
Closed	01019100002300
Closed	01019100002400
Closed	01019100002500
Closed	01019400006900
Closed	01019400007000
Closed	01019400005500
Closed	01019400004900
Closed	01019400005000
Closed	01019400005100
Closed	01019400005200
Closed	01019400005300
Closed	01019400005400
Closed	01019400005600
Closed	01019400005700
Closed	01019400004000
Closed	01019400004200
Closed	01019400003400
Closed	01019500003700
Closed	01020700000900
Closed	01019400001300
Closed	01019400001400
Closed	01019400001500
Closed	01019400001600
Closed	01019400001700
Closed	01019400001800
Closed	01019400001900
Closed	01019400002000
Closed	01019400002100
Closed	01019400002200
Closed	01019400002300
Closed	01019400002400
Closed	01019400002500
Closed	01019400002600
Closed	01019400002700
Closed	01019100007900
Closed	01019100009300
Closed	01019100009400
Closed	01019100009500
Closed	01019100008800
Closed	01019100008900
Closed	01019100007700
Closed	01019100004900
Closed	01019500003500
Closed	01019100007300
Closed	01019100003600
Closed	01019100003700

Accessory Dwelling Units

Index # - File Name: 1.0022 - Single Family Dwellings Data\_Snohomish County.pdf

Closed	01019100003800
Closed	01019100003900
Closed	01019100004000
Closed	01019100004200
Closed	01019100004300
Closed	01019100004400
Closed	01019100004500
Closed	01019100004600
Closed	01019100004700
Closed	01019100012900
Closed	01019100013600
Closed	01019100013700
Closed	01019100013900
Closed	01019100014000
Closed	01019100014100
Closed	01019100011600
Closed	01019100011400
Closed	01019100012100
Closed	01019100012200
Closed	01019100012300
Closed	01042800001600
Closed	01042800001700
Closed	01042800001800
Closed	01042800001900
Closed	01042800002000
Closed	01020300000200
Closed	01020300000300
Closed	29070900301300
Closed	01023800002200
Closed	01023800002500
Closed	01023800002600
Closed	01023800000900
Closed	01023800002000
Closed	01023800000300
Closed	01023800000400
Closed	01020300000500
Closed	28070700200600
Closed	01020300000700
Closed	01020300000800
Closed	01020300000900
Closed	01020300001000
Closed	28072000202700
Closed	30060300201000
Closed	31061800100600
Closed	32051400401200
Closed	28072900203500
Closed	27090800104300

Accessory Dwelling Units

Index # - File Name: 1.0022 - Single Family Dwellings Data\_Snohomish County.pdf

Closed	28061600102700
Closed	31043400301500
Closed	00389400200702
Closed	00480401707701
Closed	00480401707605
Closed	27081100201000
Closed	00401100008400
Closed	31040900101300
Closed	27053500101400
Closed	32090800201700
Closed	00630600002300
Closed	28062900401600
Closed	30060800103300
Closed	29072900400300
Closed	27052500105200
Closed	00927800002800
Closed	29063500101400
Closed	29063500101300
Closed	29063500101600
Closed	31061900201600
Closed	00453900000101
Closed	00926500000500
Closed	00926600001500
Closed	31040700400900
Closed	27090500400200
Closed	30050300304400
Closed	31052400401600
Closed	30060600401800
Closed	00493900003200
Closed	28062800302100
Closed	00889000004200
Closed	00889000004300
Closed	00889000004400
Closed	00889000004500
Closed	00889000004600
Closed	00609600001400
Closed	30061700101100
Closed	32052100305400
Closed	00551500012200
Closed	32062500401100
Closed	32070900301500
Closed	28071900401300
Closed	28070800400100
Closed	31060400201300
Closed	00401000005500
Closed	00401000005600
Closed	29051100102800



Accessory Dwelling Units

Index # - File Name: 1.0022 - Single Family Dwellings Data\_Snohomish County.pdf

Closed	27061500201300
Closed	27061500201500
Closed	29060300101500
Closed	29060300401900
Closed	29060300402000
Closed	27061500200300
Closed	27061500201100
Closed	32062500400200
Closed	32062500400500
Closed	32062500400600
Closed	32062500400700
Closed	32062500400800
Closed	32062500400900
Closed	32040800301100
Closed	29060300101200
Closed	29060300101300
Closed	00876200000700
Closed	28062400100200
Closed	29060300402300
Closed	00385300010300
Closed	29061000102800
Closed	29061000103000
Closed	00385700800201
Closed	00492000301800
Closed	31061700402000
Closed	32061700200200
Closed	31060400203200
Closed	31060400203300
Closed	28073200400200
Closed	29051400104000
Closed	30062100200500
Closed	32040500402400
Closed	00385300010201
Closed	28060300200700
Closed	30040800200900
Closed	31042000400700
Closed	00473300003407
Closed	00495900003400
Closed	00495900003500
Closed	30070100400300
Closed	00868400002100
Closed	00483000003300
Closed	27071800401200
Closed	27061800400200
Closed	27102000302200
Closed	27051500106000
Closed	27051400302100

Accessory Dwelling Units

Index # - File Name: 1.0022 - Single Family Dwellings Data\_Snohomish County.pdf

Closed	27090800200600
Closed	27051100302300
Closed	27051100408300
Closed	27071100100700
Closed	27071000400900
Closed	27070300102700
Closed	27070300201800
Closed	00372801300403
Closed	27063400402200
Closed	27073000301300
Closed	27062900204000
Closed	27052300202000
Closed	27052200400700
Closed	27052700303900
Closed	00373002700403
Closed	00403900020302
Closed	00403800003803
Closed	00403800002101
Closed	00403900016200
Closed	00433100000601
Closed	00452600200600
Closed	00623700005200
Closed	00629900001100
Closed	00629900001200
Closed	00576800302000
Closed	00577700503900
Closed	00577600701602
Closed	00577700601600
Closed	00621200000100
Closed	00623700000500
Closed	00617300200502
Closed	00500100000500
Closed	01067800000100
Closed	00509000002805
Closed	00512200001600
Closed	00512200002100
Closed	00512200005400
Closed	00545900000900
Closed	00373300900601
Closed	00370600000500
Closed	28073400202400
Closed	28073400302300
Closed	28063300400500
Closed	28073200102100
Closed	28072800100100
Closed	28072500300300
Closed	28072700400700

Accessory Dwelling Units

Index # - File Name: 1.0022 - Single Family Dwellings Data\_Snohomish County.pdf

Closed	28072700401200
Closed	28052900304100
Closed	28072900301700
Closed	28073000200100
Closed	28073000401700
Closed	28062300100200
Closed	28061500300400
Closed	28061400403300
Closed	28061800400200
Closed	28061100201400
Closed	28070700301100
Closed	28071000200900
Closed	28070900300900
Closed	28051100403000
Closed	28060100200800
Closed	28050300103300
Closed	28050300101000
Closed	28060600202100
Closed	28060300302000
Closed	00668900001000
Closed	00752900000300
Closed	00432700000700
Closed	00448900000100
Closed	00448900000300
Closed	00396500002300
Closed	00396500002400
Closed	00538000009502
Closed	00574100013100
Closed	00574200002802
Closed	00574200003601
Closed	00574200003800
Closed	00610300000200
Closed	00613800001600
Closed	00604100001202
Closed	00597400005100
Closed	00608100700402
Closed	00592100001400
Closed	00597400000108
Closed	00597400000109
Closed	29061400202100
Closed	29060100201300
Closed	00616900003200
Closed	00687100000300
Closed	29073200300400
Closed	29063500200900
Closed	29062700301100
Closed	29063100200400

Accessory Dwelling Units

Index # - File Name: 1.0022 - Single Family Dwellings Data\_Snohomish County.pdf

Closed	29072800200500
Closed	29062800401100
Closed	29062200400900
Closed	29062100102800
Closed	29061500401200
Closed	30062200101600
Closed	30062200101100
Closed	30062000301800
Closed	30042200301200
Closed	30071900202800
Closed	30061800300300
Closed	30061800301900
Closed	30061400405000
Closed	00828500000500
Closed	30080700201500
Closed	30041300401800
Closed	30051400100800
Closed	30040600201700
Closed	30060400101300
Closed	30050500300400
Closed	30040700400300
Closed	30060200200400
Closed	00397700000900
Closed	00454600000900
Closed	00457000002807
Closed	00471400003400
Closed	00491600002600
Closed	00491900103700
Closed	00492000108500
Closed	00504500600300
Closed	00493301400105
Closed	00597600000204
Closed	00604900001003
Closed	00597300000311
Closed	00580900000302
Closed	00581700000905
Closed	00541700000900
Closed	00625300002400
Closed	00651100000400
Closed	00629100002400
Closed	00585900002200
Closed	00581800000100
Closed	00551400005501
Closed	00551400008800
Closed	00551500001800
Closed	00551500003600
Closed	00557200402600

Accessory Dwelling Units

Index # - File Name: 1.0022 - Single Family Dwellings Data\_Snohomish County.pdf

Closed	00557300101500
Closed	00557300101600
Closed	00556800101202
Closed	00551500012000
Closed	00520200004500
Closed	00543800001000
Closed	00543800000302
Closed	00470600002300
Closed	00429900001200
Closed	00401000011500
Closed	00401000009600
Closed	30063300401500
Closed	30063200402100
Closed	30063200302000
Closed	30063200302600
Closed	31061700200100
Closed	31061700200100
Closed	31051700300100
Closed	31041800401500
Closed	31061700302900
Closed	31061700202000
Closed	31041900100200
Closed	31051900201300
Closed	31052400101700
Closed	31042400300900
Closed	31042300404700
Closed	31062100200200
Closed	31042100302500
Closed	31042100301200
Closed	31060600202400
Closed	31040700403100
Closed	31041200200300
Closed	31041200201100
Closed	31051300202700
Closed	31041300301900
Closed	31040300201800
Closed	31060400202600
Closed	31063000202400
Closed	31062900101300
Closed	31063300201600
Closed	31063500300500
Closed	31053500402700
Closed	00384300003400
Closed	00394400507801
Closed	00480700000202
Closed	00464200000300
Closed	00394510401500

Accessory Dwelling Units

Index # - File Name: 1.0022 - Single Family Dwellings Data\_Snohomish County.pdf

Closed	00394507700100
Closed	00394405201402
Closed	32053000400700
Closed	32053200402900
Closed	32062900101700
Closed	32052400200500
Closed	32042700401500
Closed	32052100103400
Closed	32062000400700
Closed	32041600102900
Closed	32081200101000
Closed	32061000202200
Closed	32100900200100
Closed	32050900202500
Closed	32050700100700
Closed	00720900000300
Closed	32060300300300
Closed	32060300300500
Closed	00499100107300
Closed	00532900001202
Closed	00494600301002
Closed	00494600301007
Closed	00494600301008
Closed	00494600301009
Closed	00587100001100
Closed	00609700006700
Closed	00490800200500
Closed	27063400300500
Closed	00625300002002
Closed	28071700300600
Closed	32071700100500
Closed	30062400301400
Closed	30062300401400
Closed	30040800401200
Closed	00844300000500
Closed	00844800000200
Closed	00844800000300
Closed	00457100003600
Closed	30060800103000
Closed	00556600011600
Closed	31062000101000
Closed	00480000011600
Closed	00842300004100
Closed	28061400101700
Closed	32042100200400
Closed	00589600008500
Closed	00587300004200

Accessory Dwelling Units

Index # - File Name: 1.0022 - Single Family Dwellings Data\_Snohomish County.pdf

Closed	00490100007000
Closed	00490400002900
Closed	00587000003200
Closed	00490500002800
Closed	00413900000900
Closed	00383700000200
Closed	00612500003300
Closed	00629600005300
Closed	00629600012300
Closed	00639500000200
Closed	00401000016400
Closed	00813000000600
Closed	29060400303600
Closed	29061700302800
Closed	00494600201403
Closed	00401000016500
Closed	00401000016600
Closed	00401000016700
Closed	29063500302600
Closed	30060700200400
Closed	00557200402500
Closed	32062500301500
Closed	29071800200200
Closed	28072900404800
Closed	28060900203200
Closed	28060800301800
Closed	00598100004600
Closed	30051200200800
Closed	30051200201200
Closed	00394507100300
Closed	00836000000500
Closed	30060800102700
Closed	32063400401500
Closed	31063300202000
Closed	27063200101700
Closed	30060500402800
Closed	00594300000602
Closed	31062000201000
Closed	31053600400600
Closed	32052000101100
Closed	00557600002901
Closed	28081900100700
Closed	00473300700502
Closed	30060500401200
Closed	27062500100500
Closed	32042600101700
Closed	30060500300900

Accessory Dwelling Units

Index # - File Name: 1.0022 - Single Family Dwellings Data\_Snohomish County.pdf

Closed	28061600203200
Closed	32072900301400
Closed	30060800201500
Closed	30060800202400
Closed	30060800202500
Closed	31062100400800
Closed	00556600012600
Closed	30062000304500
Closed	32052000100400
Closed	30073100101600
Closed	00609100004200
Closed	32060800400200
Closed	27071100100200
Closed	30062900303300
Closed	27061800202600
Closed	27072900300300
Closed	30062000101400
Closed	31053500100200
Closed	28081900400400
Closed	00373101300800
Closed	27062700402300
Closed	30060500401300
Closed	27081100200600
Closed	30061100401600
Closed	29063500402500
Closed	28052800201700
Closed	00836800001200
Closed	30062100302300
Closed	27062200400800
Closed	28072800303200
Closed	29061000102000
Closed	00577600301300
Closed	31052500201500
Closed	32041000402500
Closed	00597400002300
Closed	31060600400100
Closed	28060100100100
Closed	00401100014500
Closed	32070800100200
Closed	29061100202500
Closed	00629600005000
Closed	32050800300300
Closed	28051200305000
Closed	30061800100300
Closed	32063600201300
Closed	00383700000800
Closed	00413900002100



Accessory Dwelling Units

Index # - File Name: 1.0022 - Single Family Dwellings Data\_Snohomish County.pdf

Closed	32063400402200
Closed	32053500200900
Closed	32053300100800
Closed	00490100002200
Closed	00587200005900
Closed	00587300003500
Closed	00589600007000
Closed	27063000303200
Closed	27071800402400
Closed	27102800100100
Closed	28061100301600
Closed	00370500000602
Closed	30041700400300
Closed	30040300303100
Closed	00490900003300
Closed	00490900004900
Closed	00489800002500
Closed	00485300000600
Closed	00494511401300
Closed	32040300401200
Closed	32040300100200
Closed	32040300201000
Closed	32080100302300
Closed	00720900001000
Closed	32040800400300
Closed	32070800402500
Closed	32041000102000
Closed	32041500200700
Closed	32041500202000
Closed	32041700402000
Closed	32061700100500
Closed	32051800401100
Closed	32072000200219
Closed	32051900400900
Closed	32052200100600
Closed	32042200100800
Closed	32052100103100
Closed	32042300301900
Closed	32042300402300
Closed	32042300100600
Closed	32063100101700
Closed	32063100201100
Closed	32063100304300
Closed	32063100304100
Closed	32052900100700
Closed	00394509600900
Closed	00394510701400

Accessory Dwelling Units

Index # - File Name: 1.0022 - Single Family Dwellings Data\_Snohomish County.pdf

Closed	00394400500100
Closed	31043600400700
Closed	31042700101800
Closed	31042700304800
Closed	31052600402000
Closed	31062900302400
Closed	31053100300500
Closed	31063000301600
Closed	31063100100500
Closed	31060400202900
Closed	31040500301800
Closed	31060400401800
Closed	31040300301700
Closed	31060600300500
Closed	31040800200900
Closed	31042100301700
Closed	31042100303500
Closed	31062000100900
Closed	31042200202500
Closed	31062100101000
Closed	31042600300300
Closed	31051800202600
Closed	30073000401000
Closed	30073000401200
Closed	30063100400200
Closed	30062700302200
Closed	00423700001504
Closed	00424800000600
Closed	00401100003700
Closed	00401100013800
Closed	00401100013900
Closed	00401000005400
Closed	00400800000300
Closed	00470600003800
Closed	00470600004900
Closed	00470600005000
Closed	00470600005700
Closed	00489100003201
Closed	00489100011200
Closed	00520200002900
Closed	00511000006200
Closed	00557300101800
Closed	00557300101900
Closed	00557300103000
Closed	00557300103100
Closed	00551500003700
Closed	00551500006600

Accessory Dwelling Units

Index # - File Name: 1.0022 - Single Family Dwellings Data\_Snohomish County.pdf

Closed	00551500006700
Closed	00579800000504
Closed	00600500000500
Closed	00631600000100
Closed	00631600002700
Closed	00622400002100
Closed	00617400003500
Closed	00630800002600
Closed	00611300012401
Closed	00611300019300
Closed	00625900002800
Closed	00625600001100
Closed	30040200300500
Closed	00591200300110
Closed	00604800001106
Closed	00915700000100
Closed	00516700006800
Closed	00516700000200
Closed	00516700000500
Closed	00493401800103
Closed	00491900103600
Closed	00486200001000
Closed	00486200001300
Closed	00486200001400
Closed	00471400005800
Closed	00470800000601
Closed	00457000001502
Closed	00442100002100
Closed	00440100002103
Closed	30040200400300
Closed	30040200402800
Closed	30060200402300
Closed	30060300202100
Closed	30040300400200
Closed	30040600100400
Closed	30051200400500
Closed	30080700202100
Closed	30061100301600
Closed	30061400401600
Closed	30061400404000
Closed	30061400300700
Closed	30061700401500
Closed	30061900102100
Closed	30062000300700
Closed	29061900104400
Closed	29061900401300
Closed	29073000401100

Accessory Dwelling Units

Index # - File Name: 1.0022 - Single Family Dwellings Data\_Snohomish County.pdf

Closed	29072800300700
Closed	29062700301500
Closed	29062500200900
Closed	29063300400900
Closed	00654400000300
Closed	00654400000400
Closed	29061500100600
Closed	29061100101000
Closed	29051100107700
Closed	29060300301800
Closed	29070500401400
Closed	29060600101600
Closed	00593100000500
Closed	00587400000300
Closed	00587400000904
Closed	00614800004100
Closed	00574200000300
Closed	00574200006800
Closed	00574200006200
Closed	00538000007100
Closed	00537800004803
Closed	00511300001300
Closed	00399200001500
Closed	00420500000300
Closed	00448500000100
Closed	00448700000300
Closed	00448700000400
Closed	00426800000800
Closed	00802400003200
Closed	28070600301900
Closed	28070600401100
Closed	28050300101200
Closed	28060900202800
Closed	28061100103000
Closed	28061200301200
Closed	28061400101500
Closed	28061500100300
Closed	28061400303400
Closed	28072500202100
Closed	28072300200200
Closed	28062300102600
Closed	28082100101800
Closed	28082100101200
Closed	28052100100800
Closed	28062100400100
Closed	28072900401000
Closed	28072900301300

Accessory Dwelling Units

Index # - File Name: 1.0022 - Single Family Dwellings Data\_Snohomish County.pdf

Closed	28062800300700
Closed	28063200403100
Closed	28073500203700
Closed	28073400303700
Closed	28073400302300
Closed	28073400202900
Closed	28073300404400
Closed	28073300100500
Closed	28083500403800
Closed	00396000000800
Closed	00512200003500
Closed	00512200003600
Closed	00512000214400
Closed	00512100000700
Closed	00509200101800
Closed	00509800001600
Closed	00511900100100
Closed	00505100000101
Closed	00505100000601
Closed	00491400300305
Closed	00577700603900
Closed	00577700604900
Closed	00556600009400
Closed	00623700004800
Closed	00623700007200
Closed	00623700007300
Closed	00623700007800
Closed	00623700004000
Closed	00623700004200
Closed	00460100002700
Closed	00460100006100
Closed	00460200016100
Closed	00430400000900
Closed	00433100006000
Closed	00422800000600
Closed	00422800000900
Closed	00424100000100
Closed	00403800005503
Closed	00403900024101
Closed	00384800000400
Closed	27062700202000
Closed	27062600200300
Closed	27052500100900
Closed	27052300300700
Closed	27062900402200
Closed	27062900404100
Closed	27073000400100

Accessory Dwelling Units

Index # - File Name: 1.0022 - Single Family Dwellings Data\_Snohomish County.pdf

Closed	27073000400400
Closed	27063000300700
Closed	27063000101800
Closed	27052800104700
Closed	27063500200700
Closed	27073100201300
Closed	27073200400100
Closed	00372900600804
Closed	00373000300106
Closed	27070400200200
Closed	27090400401800
Closed	27070500202300
Closed	27071100400900
Closed	27051500301600
Closed	27051400200800
Closed	27071100401600
Closed	27051800200400
Closed	27061800201100
Closed	27062000401300
Closed	27071800102300
Closed	27101900201700
Closed	27062000100700
Closed	00597400002200
Closed	32052000100600
Closed	32063300301000
Closed	32063300303800
Closed	28072600402800
Closed	00870400000400
Closed	28071000400900
Closed	00870700000500
Closed	29061300201800
Closed	29061300201700
Closed	29061300203100
Closed	27051500200200
Closed	00493000002200
Closed	29061000102900
Closed	32090800400700
Closed	29060300101400
Closed	32062500401000
Closed	27061500201200
Closed	27073200200700
Closed	31052500302800
Closed	28071900100300
Closed	28071900401400
Closed	00885500003100
Closed	00885900000300
Closed	00885900000400

Accessory Dwelling Units

Index # - File Name: 1.0022 - Single Family Dwellings Data\_Snohomish County.pdf

Closed	32063200304500
Closed	28060800202400
Closed	00794600003000
Closed	32063200304700
Closed	28061200301900
Closed	30072900402300
Closed	00960009302800
Closed	30073200101000
Closed	00614800001800
Closed	31052700400400
Closed	00913400001200
Closed	00913400001200
Closed	00597400000203
Closed	28081900400500
Closed	32060900401000
Closed	31061800101900
Closed	00401100013100
Closed	00401000012600
Closed	32071600201300
Closed	30061100101900
Closed	30061100101400
Closed	30061100104200
Closed	30061100102900
Closed	32090800401500
Closed	00911300000800
Closed	29070500201700
Closed	00611300007800
Closed	32053400203100
Closed	01023800002300
Closed	30062500100600
Closed	00543400001300
Closed	01019100012400
Closed	01019100012500
Closed	01019100012600
Closed	01019100012700
Closed	01019100012800
Closed	01019100011500
Closed	01019100011300
Closed	01019100012000
Closed	01019100011700
Closed	01019100013800
Closed	01019100013000
Closed	01019100013100
Closed	01019100013200
Closed	01019100013300
Closed	01019100013400
Closed	01019500003600

Accessory Dwelling Units

Index # - File Name: 1.0022 - Single Family Dwellings Data\_Snohomish County.pdf

Closed	31042600202200
Closed	01019100010500
Closed	00403900024403
Closed	00403900024404
Closed	01019500003800
Closed	01019500003900
Closed	01019500004000
Closed	01019500004100
Closed	01019500004200
Closed	01019400004300
Closed	01019400004400
Closed	01019400004500
Closed	01019400004600
Closed	01019400004700
Closed	01019400004800
Closed	01019400004100
Closed	01019400005800
Closed	01023800004500
Closed	01024300004000
Closed	01024300004100
Closed	01024300004200
Closed	01024300004300
Closed	01024800000700
Closed	28083500302100
Closed	01025000001800
Closed	01025000001900
Closed	01019500003300
Closed	01019500003400
Closed	27061500201000
Closed	00579100002204
Closed	28082100100800
Closed	28073300203400
Closed	28050300303500
Closed	01011500000400
Closed	01011500000500
Closed	01025000002300
Closed	01029200001100
Closed	01029200001200
Closed	32080200404000
Closed	00622400002200
Closed	00496400002000
Closed	27071100301000
Closed	28083000303800
Closed	28072500202500
Closed	30072800201400
Closed	32063100300700
Closed	01034500001200



Accessory Dwelling Units

Index # - File Name: 1.0022 - Single Family Dwellings Data\_Snohomish County.pdf

Closed	01034100001800
Closed	01034100001900
Closed	01034100002000
Closed	01034100002100
Closed	01034100002200
Closed	01034100002300
Closed	01034100002400
Closed	01034100001500
Closed	01034100001600
Closed	30061800102600
Closed	01034100001200
Closed	01034100001300
Closed	01034100004600
Closed	01034100003000
Closed	01034100002600
Closed	01034100004200
Closed	01034100004900
Closed	01034100005000
Closed	01034100005100
Closed	01034100005200
Closed	01034100005300
Closed	01034100005400
Closed	01034100003200
Closed	01035300001200
Closed	01035300001500
Closed	01035300001600
Closed	01035300001700
Closed	30073200401100
Closed	29070500101800
Closed	01035300000100
Closed	30073200402400
Closed	30073200401300
Closed	29070500101500
Closed	29070500101600
Closed	29070500101700
Closed	29070500102000
Closed	29070500102200
Closed	29070500102700
Closed	29070500102600
Closed	29070500102500
Closed	01049500002100
Closed	28061600300900
Closed	01039600000200
Closed	01035800003100
Closed	01036500000100
Closed	01036500000800
Closed	01040500001000

Accessory Dwelling Units

Index # - File Name: 1.0022 - Single Family Dwellings Data\_Snohomish County.pdf

Closed	01036500001100
Closed	01040500003100
Closed	01040500003200
Closed	01040500002900
Closed	01044100000700
Closed	01044100000800
Closed	01047100001000
Closed	01046800001100
Closed	01046800000800
Closed	32052200402000
Closed	01046800003800
Closed	01046800002200
Closed	01046800000100
Closed	01044800002000
Closed	01044800002100
Closed	01044800002200
Closed	01044800002300
Closed	01043800104200
Closed	01043500001900
Closed	01044800001700
Closed	01044800001800
Closed	01042900004100
Closed	01042900003000
Closed	01043800104600
Closed	27062800104000
Closed	01042900005100
Closed	01042900003800
Closed	01043800201100
Closed	01043800202400
Closed	01043800200300
Closed	01043800200400
Closed	01043800104400
Closed	01043800103300
Closed	01043800103400
Closed	01043800102200
Closed	01043800102300
Closed	01043800102400
Closed	01043800102500
Closed	01043800102600
Closed	01046000000500
Closed	01043800102000
Closed	01043800102800
Closed	01043800103000
Closed	01043800103100
Closed	01043800103600
Closed	01043800103700
Closed	01043800103800

Accessory Dwelling Units

Index # - File Name: 1.0022 - Single Family Dwellings Data\_Snohomish County.pdf

Closed	0104600000700
Closed	0104600000800
Closed	0104600000900
Closed	0104600001000
Closed	01043800101300
Closed	01043800101400
Closed	01043800101500
Closed	01043800101600
Closed	01043800101700
Closed	01042900001100
Closed	01043800100100
Closed	01043800100200
Closed	01043800100300
Closed	01043800100400
Closed	01043800100500
Closed	01043800100600
Closed	01043800100700
Closed	01043800100800
Closed	01043800100900
Closed	01043800101000
Closed	01043800101100
Closed	01046000001300
Closed	01046000001400
Closed	01046000001600
Closed	01046000001700
Closed	01046000001800
Closed	01046000001900
Closed	01046000002000
Closed	01042500007200
Closed	01042500007300
Closed	01042500007400
Closed	01042500007500
Closed	01046000000200
Closed	01042500006100
Closed	01042500004800
Closed	01042500004900
Closed	01042500001100
Closed	01042500004300
Closed	01042500004400
Closed	01042500000400
Closed	01042000010000
Closed	01042000010100
Closed	01042000007900
Closed	01042000009300
Closed	01042000009400
Closed	01042000009500
Closed	01042000009600

Accessory Dwelling Units

Index # - File Name: 1.0022 - Single Family Dwellings Data\_Snohomish County.pdf

Closed	01042000009700
Closed	01042000008800
Closed	01042000007400
Closed	01042000007500
Closed	01042000007600
Closed	01042000007700
Closed	01043600005600
Closed	01042000004800
Closed	01042000004900
Closed	01042000005000
Closed	01042000005100
Closed	01042000005200
Closed	01042000005300
Closed	01042000005400
Closed	01042000001300
Closed	01042000001400
Closed	01042000001500
Closed	01043600004900
Closed	01054400003800
Closed	01054400003900
Closed	01054400003200
Closed	01054400003300
Closed	01054400003400
Closed	01054400003500
Closed	01054400003600
Closed	01048500004600
Closed	01048500002300
Closed	01048500002400
Closed	01048500002100
Closed	01048500001700
Closed	00394406201304
Closed	01048500001500
Closed	00413900002300
Closed	28042900400700
Closed	01041700002000
Closed	01041700000800
Closed	01041700005000
Closed	01041700004900
Closed	01041700000300
Closed	01041700000400
Closed	01041700000500
Closed	01041700000600
Closed	01041700005800
Closed	01041700005700
Closed	01041700005600
Closed	01041700005500
Closed	01038000000800

Accessory Dwelling Units

Index # - File Name: 1.0022 - Single Family Dwellings Data\_Snohomish County.pdf

Closed	0103800000900
Closed	30061100104400
Closed	30061100104000
Closed	30061100104100
Closed	30061100103900
Closed	01048500006300
Closed	01048500006400
Closed	01038000004700
Closed	01038000004800
Closed	01038000004900
Closed	01038000005000
Closed	01038000003700
Closed	01038000003800
Closed	01038000003900
Closed	01038000004000
Closed	01038000003400
Closed	01038000003500
Closed	01038000003100
Closed	01038000003200
Closed	01038000001900
Closed	01041700001800
Closed	01047800000100
Closed	01047800000200
Closed	01047800000300
Closed	01047800001100
Closed	01047800001200
Closed	01047800001300
Closed	01047800001400
Closed	31051700103100
Closed	01041500000900
Closed	01054400002800
Closed	01054400002900
Closed	01054400003000
Closed	01054400002500
Closed	01054400002600
Closed	01047800000500
Closed	01047800000600
Closed	01042600000100
Closed	01054400000800
Closed	01054400000900
Closed	01054400001000
Closed	01054400000100
Closed	01054400000200
Closed	01054400000300
Closed	01054400001900
Closed	01054400002000
Closed	01054400002100

Accessory Dwelling Units

Index # - File Name: 1.0022 - Single Family Dwellings Data\_Snohomish County.pdf

Closed	01054400002200
Closed	30062400401800
Closed	29062100102100
Closed	28070800301200
Closed	32080200403500
Closed	00617000005700
Closed	28083500301400
Closed	00937100001900
Closed	00491900300001
Closed	00935400001500
Closed	00935400001700
Closed	00935400001700
Closed	30050200401200
Closed	30062400302700
Closed	00933300002900
Closed	27052600402300
Closed	30062100102700
Closed	32063200404200
Closed	30060100301700
Closed	31051700100200
Closed	28050100201600
Closed	30043600201000
Closed	00513700003404
Closed	28060900402600
Closed	29070800101500
Closed	00956600001400
Closed	27060300402400
Closed	00600300201200
Closed	00960013105400
Closed	01000400000600
Closed	01000100000500
Closed	01000100000800
Closed	01000100000900
Closed	01000100001000
Closed	01000100001100
Closed	01000100001200
Closed	01000100001300
Closed	00475900000200
Closed	28050300302800
Closed	00394507600701
Closed	00457000004301
Closed	00457000004300
Closed	30073300200600
Closed	00556600009600
Closed	00557100406700
Closed	29062500301300
Closed	01063200000400

Accessory Dwelling Units

Index # - File Name: 1.0022 - Single Family Dwellings Data\_Snohomish County.pdf

Closed	01063200000500
Closed	01063200000600
Closed	01063200000700
Closed	01063200000800
Closed	00373100500206
Closed	00373100500207
Closed	00373100500208
Closed	00373100500209
Closed	00373100500210
Closed	00373100500213
Closed	27051500301100
Closed	30061800402200
Closed	01057800000200
Closed	01057800000300
Closed	01057800000400
Closed	01057800000500
Closed	01057800000600
Closed	01057800000700
Closed	01057800000800
Closed	01057800000900
Closed	01057800001000
Closed	01057800001100
Closed	01057800001200
Closed	01057800001300
Closed	01057800001400
Closed	01057800001500
Closed	01057800001600
Closed	01057800001700
Closed	01057800001800
Closed	01057800001900
Closed	01057800002100
Closed	01057800002300
Closed	01057800002400
Closed	01057800002500
Closed	01057800002700
Closed	01057800002800
Closed	29061700308600
Closed	29061700308700
Closed	29061700308800
Closed	01082500002700
Closed	01082500002800
Closed	01082500001100
Closed	01062400000100
Closed	01062400000200
Closed	01062400000300
Closed	01062400000500
Closed	01058200000300

Accessory Dwelling Units

Index # - File Name: 1.0022 - Single Family Dwellings Data\_Snohomish County.pdf

Closed	01058200000500
Closed	01058200000600
Closed	01058200000700
Closed	01058200000800
Closed	01057800000100
Closed	00466100002400
Closed	01071900000400
Closed	01071900000500
Closed	01071900000700
Closed	01071900000800
Closed	01071900000900
Closed	01071900001000
Closed	01071900001300
Closed	01063500003900
Closed	01063500004000
Closed	01063500004200
Closed	01063500004300
Closed	01063500004400
Closed	01063500004600
Closed	01063500005300
Closed	01063500005600
Closed	01063500006200
Closed	01064900001000
Closed	01064900001100
Closed	01064900001200
Closed	01064900001300
Closed	01064900001400
Closed	01064900001500
Closed	01056400000400
Closed	01064900002000
Closed	01062500000400
Closed	01062500000500
Closed	01062500000700
Closed	01058300000100
Closed	01058300000600
Closed	01058300000800
Closed	01058300000900
Closed	01058300001200
Closed	00509200201603
Closed	00509200201604
Closed	00403900018302
Closed	00373100500205
Closed	01056400000700
Closed	01056400000900
Closed	01056400001000
Closed	01057700000300
Closed	01061600000100



Accessory Dwelling Units

Index # - File Name: 1.0022 - Single Family Dwellings Data\_Snohomish County.pdf

Closed	01061600000300
Closed	01061600000900
Closed	01059200001300
Closed	00623600005300
Closed	01059200000500
Closed	01059200000600
Closed	01059200000700
Closed	01059200000800
Closed	01059200000900
Closed	01059200001000
Closed	01058300003300
Closed	01058300003400
Closed	01058300003500
Closed	01059200000100
Closed	01059200000200
Closed	01059200000300
Closed	01064400001700
Closed	01064400001900
Closed	01064400002000
Closed	01064400002100
Closed	01064400002200
Closed	01064400002300
Closed	01064400002400
Closed	01064400002500
Closed	01064400002600
Closed	01064400002700
Closed	01064400002800
Closed	01064400002900
Closed	01064400003000
Closed	01064400003100
Closed	01064400003200
Closed	01064400003300
Closed	01064400003400
Closed	01064400003500
Closed	01064400003700
Closed	01064400003800
Closed	01064400003900
Closed	01064400004000
Closed	01064400004100
Closed	01064400004200
Closed	01064400004300
Closed	01064400004400
Closed	01064400004500
Closed	01064400004600
Closed	01064400005500
Closed	01064400005600
Closed	01064400005700

Accessory Dwelling Units

Index # - File Name: 1.0022 - Single Family Dwellings Data\_Snohomish County.pdf

Closed	01064400005800
Closed	01064400005900
Closed	28060300304700
Closed	01055600000800
Closed	01059400001000
Closed	01059400001100
Closed	01059400001200
Closed	01059400000700
Closed	01059400000800
Closed	00470800000801
Closed	00470800000802
Closed	01056300000101
Closed	01055600000200
Closed	01055600000300
Closed	01057700000500
Closed	01057700000600
Closed	01056300000201
Closed	01056300000401
Closed	01056300000501
Closed	01056300000601
Closed	01056300000701
Closed	01058900002900
Closed	01058900003000
Closed	01058900003100
Closed	01058900003200
Closed	01058900000700
Closed	01058900000800
Closed	01058900000300
Closed	01058900000100
Closed	01075500002300
Closed	01075500002400
Closed	01075500002500
Closed	01075500002600
Closed	01075500002700
Closed	01058900001000
Closed	01058900001100
Closed	01058900001200
Closed	01058900001300
Closed	01058900001400
Closed	01058900001500
Closed	01058900001600
Closed	01058900001700
Closed	01058900001800
Closed	01058900001900
Closed	01058900002000
Closed	01058900002100
Closed	01058900002200

Accessory Dwelling Units

Index # - File Name: 1.0022 - Single Family Dwellings Data\_Snohomish County.pdf

Closed	01058900002200
Closed	01058900002300
Closed	01058900002400
Closed	01075500002900
Closed	01075500003000
Closed	01075500003100
Closed	01075500003200
Closed	01075500003300
Closed	01075500003400
Closed	01075500003500
Closed	01075500003600
Closed	01075500003700
Closed	01075500003800
Closed	01075500003900
Closed	01075500004000
Closed	01075500004100
Closed	01075500004200
Closed	01075500004300
Closed	01075500004400
Closed	01075500004500
Closed	01075500004600
Closed	01075500004700
Closed	01075500004800
Closed	01075500004900
Closed	01075500005000
Closed	01075500005100
Closed	01075500005200
Closed	01075500005300
Closed	01075500005400
Closed	01075500005500
Closed	01075500001500
Closed	01075500001600
Closed	01075500001700
Closed	01075500001900
Closed	01075500002000
Closed	01075500002100
Closed	01055800000500
Closed	01075500001100
Closed	01075500001200
Closed	01075500001300
Closed	00401100009100
Closed	01054700004300
Closed	32041400100300
Closed	01055800000100
Closed	01055800000200
Closed	00557100403500
Closed	01059100000200

Accessory Dwelling Units

Index # - File Name: 1.0022 - Single Family Dwellings Data\_Snohomish County.pdf

Closed	01059100000300
Closed	00511900201402
Closed	01059100000400
Closed	01059100000800
Closed	01059100000900
Closed	01054700007600
Closed	01059100001500
Closed	01059100001600
Closed	01075500000100
Closed	01075500000200
Closed	01075500000300
Closed	01075500000500
Closed	01075500000600
Closed	01075500000700
Closed	01075500000800
Closed	01075500000900
Closed	01075500001000
Closed	00587000003600
Closed	01062400002100
Closed	01062400002200
Closed	01062400002300
Closed	01062400002400
Closed	01068700000100
Closed	01062400001700
Closed	01062400001800
Closed	01062400001900
Closed	01061500000600
Closed	01061500001100
Closed	01061500001200
Closed	01061500001300
Closed	01061500001400
Closed	01061500001500
Closed	01061500001600
Closed	01061500001700
Closed	01061500001800
Closed	01061500001900
Closed	01061500002000
Closed	30060200204700
Closed	01061500002100
Closed	01061500002200
Closed	01061500002300
Closed	01061500002400
Closed	01061500002500
Closed	01061500003700
Closed	01061500003800
Closed	01061500004600
Closed	01068700000200

Accessory Dwelling Units

Index # - File Name: 1.0022 - Single Family Dwellings Data\_Snohomish County.pdf

Closed	01068700000300
Closed	01068700000400
Closed	01068700000500
Closed	01068700000600
Closed	01068700000700
Closed	01068700001000
Closed	01068700001100
Closed	01061500003500
Closed	01061500004300
Closed	01068700001300
Closed	01068700001400
Closed	01068700001600
Closed	01068700002100
Closed	01068700005400
Closed	01068700005500
Closed	01068700005600
Closed	01068700005700
Closed	01068700005800
Closed	01068700005900
Closed	01068700006000
Closed	01068700006100
Closed	01068700006200
Closed	01068700006300
Closed	01068700006400
Closed	01068700006500
Closed	01068700006600
Closed	01068700006700
Closed	01068700006800
Closed	01068700006900
Closed	01068700007500
Closed	01068700007600
Closed	01068700007700
Closed	01068700007800
Closed	01076300000600
Closed	01076300000800
Closed	01076300000900
Closed	01076300001000
Closed	01076300001100
Closed	01076300001200
Closed	01076300001300
Closed	01076300001400
Closed	01076300001500
Closed	01076300001600
Closed	01076300001700
Closed	01076300001800
Closed	01076300001900
Closed	01076300002000

Accessory Dwelling Units

Index # - File Name: 1.0022 - Single Family Dwellings Data\_Snohomish County.pdf

Closed	01076300002100
Closed	01076300002200
Closed	01076300002300
Closed	01076300002400
Closed	01076300002500
Closed	01076300002600
Closed	01076300002700
Closed	01076300002800
Closed	01076300002900
Closed	01076300003000
Closed	01076300003100
Closed	01076300003200
Closed	01068700002800
Closed	32051400401100
Closed	01066200000200
Closed	01066200000400
Closed	01066200003400
Closed	01066200003000
Closed	01066200004800
Closed	01066200004900
Closed	01066200005000
Closed	01063000000700
Closed	01063000000800
Closed	01063000000900
Closed	01063000001000
Closed	01063000001100
Closed	01063000001200
Closed	01063000001300
Closed	01063000001400
Closed	01063000001500
Closed	01063000001600
Closed	01063000001700
Closed	00401100009000
Closed	01063000000100
Closed	01063000000200
Closed	01063000000300
Closed	01063000000400
Closed	01063000000500
Closed	00373700501406
Closed	00373700501407
Closed	00373700501409
Closed	00373700501410
Closed	31042100200800
Closed	01064100000100
Closed	01064100000200
Closed	01064100000900
Closed	01064100001000

Accessory Dwelling Units

Index # - File Name: 1.0022 - Single Family Dwellings Data\_Snohomish County.pdf

Closed	01064100000600
Closed	01064100000700
Closed	01064100001300
Closed	01064100001500
Closed	01064100001600
Closed	01064100001700
Closed	01064100001800
Closed	32080900202000
Closed	27062700305200
Closed	27062700305400
Closed	01066500000200
Closed	01066500000300
Closed	01066500000400
Closed	01066500000500
Closed	01066500000800
Closed	01066500000900
Closed	01066500001000
Closed	01066500001100
Closed	30062400402100
Closed	00394404102100
Closed	01066500001400
Closed	01066500001500
Closed	01066500001700
Closed	01066500001800
Closed	01066500001900
Closed	01066500002000
Closed	01066500002100
Closed	28051700412100
Closed	28051700412300
Closed	32042700101400
Closed	00454600000800
Closed	30050200200400
Closed	00599900000800
Closed	28050300202600
Closed	01068500000100
Closed	01068500000200
Closed	01068500000800
Closed	28052100102200
Closed	00466700007900
Closed	00563100000609
Closed	00373101100103
Closed	00490700000200
Closed	01069200000500
Closed	01069200000600
Closed	01069200001600
Closed	01069200001700
Closed	01069200001800

Accessory Dwelling Units

Index # - File Name: 1.0022 - Single Family Dwellings Data\_Snohomish County.pdf

Closed	01069200002400
Closed	01069200003200
Closed	01069200003300
Closed	01069200003400
Closed	01069200003500
Closed	01069200004300
Closed	28070800301400
Closed	00600300500700
Closed	28050300202800
Closed	27061600400300
Closed	28052700202000
Closed	28052700202100
Closed	28052700202200
Closed	01069200002900
Closed	01071200000100
Closed	01071200000200
Closed	01071200000300
Closed	01071200000500
Closed	01071200000800
Closed	00597500000213
Closed	00597500000212
Closed	32080100401800
Closed	01047500000100
Closed	01047500000200
Closed	01047500000900
Closed	01047500001000
Closed	01047500001300
Closed	01047500001400
Closed	01047500001500
Closed	01047500000400
Closed	01047500000500
Closed	01047500000600
Closed	01047500000700
Closed	01047500002300
Closed	01047500002400
Closed	01047500002500
Closed	01047500002600
Closed	32042200300700
Closed	28070800302300
Closed	01047500003000
Closed	01047500003100
Closed	01068600000100
Closed	27051800105300
Closed	01068600001400
Closed	01068600001500
Closed	01068600001600
Closed	01068600001700



Accessory Dwelling Units

Index # - File Name: 1.0022 - Single Family Dwellings Data\_Snohomish County.pdf

Closed	01068600001800
Closed	01068600001900
Closed	01068600002000
Closed	01068600002100
Closed	01068600002200
Closed	00373002101107
Closed	00373002101108
Closed	00373002101109
Closed	00373002101110
Closed	00373002101111
Closed	00373002101112
Closed	00373002101113
Closed	00373002101114
Closed	00466100006800
Closed	00394401907700
Closed	00401000005201
Closed	29071900101200
Closed	01075900007100
Closed	01075900007200
Closed	01075900008200
Closed	01075900008000
Closed	01075900010100
Closed	01072800000700
Closed	01072800000800
Closed	01072800000900
Closed	01072800001000
Closed	01072800001100
Closed	01072400000100
Closed	01072400000200
Closed	01072400000300
Closed	28051700411200
Closed	28051700411400
Closed	28051700411600
Closed	01072800000300
Closed	01072400000600
Closed	01072500000100
Closed	01072500000400
Closed	01072500000500
Closed	01072500000600
Closed	01072500000900
Closed	01073800000200
Closed	01073800000300
Closed	01073800000400
Closed	01075000000700
Closed	01075000000800
Closed	01075000000900
Closed	01075000001000

Accessory Dwelling Units

Index # - File Name: 1.0022 - Single Family Dwellings Data\_Snohomish County.pdf

Closed	01075000001100
Closed	01077200000200
Closed	31060600204000
Closed	01057200005800
Closed	01057200005900
Closed	01057200002600
Closed	01057200002700
Closed	01057200002800
Closed	01057200004500
Closed	01057200004600
Closed	01057200004700
Closed	01057200004800
Closed	01057200004200
Closed	01057200004300
Closed	01057200006700
Closed	01057200007000
Closed	01057200007300
Closed	01057200007400
Closed	01057200007500
Closed	01057200007600
Closed	01057200003700
Closed	01057200003800
Closed	01057200003900
Closed	01057200004000
Closed	01057200002400
Closed	01057200002100
Closed	01057200002200
Closed	01053800002500
Closed	01053800002800
Closed	01053800003100
Closed	01066900006000
Closed	32053300400400
Closed	28052200304100
Closed	01055500000400
Closed	01055500000500
Closed	01053800001100
Closed	01053800000200
Closed	01053800000300
Closed	01053800000400
Closed	01053800000700
Closed	01053800000800
Closed	31060700201700
Closed	01052900000400
Closed	32051900402200
Closed	01053800002000
Closed	01053800002100
Closed	01054000000700

Accessory Dwelling Units

Index # - File Name: 1.0022 - Single Family Dwellings Data\_Snohomish County.pdf

Closed	0105400000800
Closed	0105400000900
Closed	0105400001000
Closed	0105400001100
Closed	0105400001200
Closed	0105400001300
Closed	0105400001400
Closed	0105400001500
Closed	0105400001600
Closed	0105400001700
Closed	28072700401500
Closed	0105330000800
Closed	0105330000900
Closed	0105330001000
Closed	0105330001500
Closed	0105330001600
Closed	0105330001700
Closed	0105330001800
Closed	0105330001900
Closed	01052700004900
Closed	01052700005300
Closed	01089100002800
Closed	01089100002900
Closed	01089100003000
Closed	01089100003100
Closed	01089100003200
Closed	01089100003300
Closed	01089100003400
Closed	01089100000100
Closed	30061100103700
Closed	30061100104600
Closed	30061100104700
Closed	30061100104500
Closed	01089100000200
Closed	01089100000300
Closed	01089100000400
Closed	01089100000500
Closed	01089100000600
Closed	01089100000700
Closed	01052700004600
Closed	01052700002900
Closed	01052700004100
Closed	01052700004200
Closed	01052700004300
Closed	01052700004400
Closed	01052700003300
Closed	01052700003800

Accessory Dwelling Units

Index # - File Name: 1.0022 - Single Family Dwellings Data\_Snohomish County.pdf

Closed	01052700002600
Closed	01052700002700
Closed	00466500002900
Closed	01052700000100
Closed	01052700001900
Closed	01052800002000
Closed	01052800002400
Closed	01052800002500
Closed	01052800002600
Closed	01052800002700
Closed	01052800002800
Closed	01052700000500
Closed	01052700000600
Closed	01052700000700
Closed	01052700000800
Closed	01052700000900
Closed	01052700001000
Closed	01052700001100
Closed	01052700001200
Closed	01052700001300
Closed	01052600000500
Closed	01052600000600
Closed	01052600000700
Closed	01052600000800
Closed	01052600000900
Closed	01052600001000
Closed	01052600001300
Closed	29061100302200
Closed	28072800103500
Closed	01052800003600
Closed	01052600000200
Closed	01052600000300
Closed	01052800001800
Closed	01052800001400
Closed	01052800001500
Closed	01052800000700
Closed	01052800000900
Closed	01052800001000
Closed	01052800001100
Closed	01052800001200
Closed	01050600000400
Closed	01050600000600
Closed	01050600000700
Closed	01050600000800
Closed	01050600000900
Closed	01050600001000
Closed	01050600001100

Accessory Dwelling Units

Index # - File Name: 1.0022 - Single Family Dwellings Data\_Snohomish County.pdf

Closed	01050600001300
Closed	01067900000100
Closed	01067900000200
Closed	01067900000300
Closed	01067900000400
Closed	01067900000700
Closed	01067900000800
Closed	01067900000900
Closed	01067900001000
Closed	01067900001100
Closed	01067900001200
Closed	01067900001300
Closed	01067900001400
Closed	01067900001900
Closed	01067900002000
Closed	01067900002100
Closed	01067900002200
Closed	01067900002300
Closed	01067900002800
Closed	01067900002900
Closed	01067900003100
Closed	01067900003200
Closed	01067900003300
Closed	01067900003400
Closed	27071100100100
Closed	29060300402600
Closed	01058000010000
Closed	01058000010100
Closed	01058000010200
Closed	01058000010300
Closed	01058000009500
Closed	01058000009600
Closed	01058000009700
Closed	01058000009800
Closed	01068900002700
Closed	01068900002800
Closed	01068900002900
Closed	01058000004600
Closed	01058000004700
Closed	01058000004800
Closed	01058000005100
Closed	01058000005200
Closed	01058000005300
Closed	01058000005400
Closed	01058000005500
Closed	01058000005800
Closed	01058000005900

Accessory Dwelling Units

Index # - File Name: 1.0022 - Single Family Dwellings Data\_Snohomish County.pdf

Closed	01058000006000
Closed	01058000006100
Closed	01058000006200
Closed	01058000006300
Closed	01068900001900
Closed	01068900002000
Closed	01068900002100
Closed	01068900002200
Closed	01068900002300
Closed	01068900002400
Closed	01068900000200
Closed	01068900000300
Closed	01068900000400
Closed	01068900000500
Closed	01068900000600
Closed	01049700011200
Closed	01049700011300
Closed	01049700011400
Closed	01049700011500
Closed	01049700011600
Closed	01049700011700
Closed	01049700011800
Closed	01049700011900
Closed	01049700009400
Closed	01049700009500
Closed	01049700009600
Closed	01049700009700
Closed	01049700009800
Closed	01049700009100
Closed	01049700009200
Closed	01049700010000
Closed	01049700010200
Closed	01049700010300
Closed	01049700010400
Closed	01049700010600
Closed	01049700010700
Closed	01049700010800
Closed	01049700010900
Closed	01049700011000
Closed	01049700004700
Closed	01049700004800
Closed	01049700004900
Closed	01049700005000
Closed	01049700005100
Closed	01049700005200
Closed	01049700005300
Closed	01049700005400

Accessory Dwelling Units

Index # - File Name: 1.0022 - Single Family Dwellings Data\_Snohomish County.pdf

Closed	01049700005500
Closed	01049700002300
Closed	01049700002400
Closed	01049700002500
Closed	01049700002600
Closed	01049700002700
Closed	01049700008600
Closed	01049700008700
Closed	01049700005900
Closed	01049700006000
Closed	01049700006100
Closed	01049700006200
Closed	01049700006300
Closed	01049700006400
Closed	01049700006500
Closed	01049700006600
Closed	01049700006700
Closed	01049700006800
Closed	01049700006900
Closed	01049700007000
Closed	01049700007100
Closed	01049700007200
Closed	01049700007300
Closed	01049700007400
Closed	01049700007500
Closed	01049700007600
Closed	01049700007700
Closed	01049700007800
Closed	01049700007900
Closed	01049700008000
Closed	01049700008100
Closed	01049700008200
Closed	01049700004400
Closed	01049700003600
Closed	01049700001200
Closed	01049700001300
Closed	01049700001400
Closed	01049700001500
Closed	01049700000600
Closed	01049700000900
Closed	32051800202100
Closed	00471400005700
Closed	00493300900511
Closed	00493300900512
Closed	00493300900508
Closed	01053400000600
Closed	01060300001400

Accessory Dwelling Units

Index # - File Name: 1.0022 - Single Family Dwellings Data\_Snohomish County.pdf

Closed	01060300000800
Closed	01060300000900
Closed	01060300001000
Closed	01054600001700
Closed	01054600001800
Closed	01054600001500
Closed	01054600001200
Closed	00556600004400
Closed	31062900401100
Closed	01054600000100
Closed	01054600000600
Closed	01054600000800
Closed	01054600000900
Closed	01052300000600
Closed	01052300000700
Closed	01053000001700
Closed	01048700004400
Closed	01048700000500
Closed	01048700000100
Closed	01048700000200
Closed	32053500300600
Closed	01057300000200
Closed	01057300000300
Closed	01057300000400
Closed	01057300000500
Closed	01048700003300
Closed	01048700003400
Closed	01048700003500
Closed	01048700003600
Closed	01048700003700
Closed	01048700003800
Closed	01048700003900
Closed	01048700004000
Closed	01048700004100
Closed	01048700004200
Closed	01050200000800
Closed	01048700002900
Closed	01050200001600
Closed	01050200001700
Closed	01050200001800
Closed	01050200001900
Closed	01050200002000
Closed	01050200001300
Closed	01050200000300
Closed	01050200000400
Closed	01050200000500
Closed	01050200000600



Accessory Dwelling Units

Index # - File Name: 1.0022 - Single Family Dwellings Data\_Snohomish County.pdf

Closed	27040200300400
Closed	27040200300400
Closed	27040200300400
Closed	27040200300400
Closed	27040200300400
Closed	01053000002500
Closed	00498700001300
Closed	27040200300400
Closed	27040200300400
Closed	27040200300400
Closed	27040200300400
Closed	27040200300400
Closed	27040200300400
Closed	27040200300400
Closed	27040200300400
Closed	27040200300400
Closed	27040200300400
Closed	27040200300400
Closed	27040200300400
Closed	27040200300400
Closed	27040200300400
Closed	27040200300400
Closed	27040200300400
Closed	27040200300400
Closed	27040200300400
Closed	27040200300400
Closed	27040200300400
Closed	27040200300400
Closed	27040200300400
Closed	27040200300400
Closed	27040200300400
Closed	27040200300400
Closed	27040200300400
Closed	27040200300400
Closed	00949300001400
Closed	00949300001500
Closed	01053000002000
Closed	01053000002100
Closed	01053000002200
Closed	01053000001400
Closed	01048000010800
Closed	01053000000700
Closed	01053000000800
Closed	01053000000900
Closed	01048000009900
Closed	01048000010000
Closed	01048000010100
Closed	01048000010300
Closed	01048000011100
Closed	01048000011200
Closed	00490100003900
Closed	01048000009200
Closed	01048000009300
Closed	01048000008200
Closed	01048000008300
Closed	01048000008400
Closed	01048000008000
Closed	01048000006500

Accessory Dwelling Units

Index # - File Name: 1.0022 - Single Family Dwellings Data\_Snohomish County.pdf

Closed	01048000006600
Closed	01048000006800
Closed	01045900000300
Closed	01048000000800
Closed	01048000000900
Closed	01048000001700
Closed	01045900000100
Closed	28053300107600
Closed	28053300107700
Closed	28053300107800
Closed	01048000003100
Closed	01048000003200
Closed	01048000002800
Closed	01048000002900
Closed	01048000005500
Closed	01048000005700
Closed	01048000005800
Closed	01048000005900
Closed	01048000006000
Closed	01048000006100
Closed	01048000006200
Closed	01048000006300
Closed	28072800303100
Closed	32042500302000
Closed	32042500302100
Closed	00568800100806
Closed	28053300107500
Closed	00579200001504
Closed	00556600004600
Closed	01079700001000
Closed	01079700001100
Closed	01079700001200
Closed	01079700001300
Closed	01079700001400
Closed	01079700001500
Closed	01079700001600
Closed	01043700002000
Closed	01079700000600
Closed	01079700000700
Closed	01043700001800
Closed	01044100001000
Closed	01079700000100
Closed	01079700000200
Closed	01079700000300
Closed	01079700000400
Closed	01043700001400
Closed	01043700001500

Accessory Dwelling Units

Index # - File Name: 1.0022 - Single Family Dwellings Data\_Snohomish County.pdf

Closed	01047100002200
Closed	01047100002300
Closed	01047100002400
Closed	01043700000500
Closed	29061600301500
Closed	28061100103500
Closed	28061100103600
Closed	30053000100100
Closed	28061100103300
Closed	00538000013908
Closed	01084700004700
Closed	01084700004800
Closed	01084700004900
Closed	01084700005000
Closed	01084700003300
Closed	01084700003400
Closed	32053100404200
Closed	01084400001200
Closed	01081400000200
Closed	01081400000300
Closed	01081400002100
Closed	01081400002200
Closed	01081400002500
Closed	01081400002600
Closed	32052000402200
Closed	00527000001502
Closed	00527000001503
Closed	30072800200200
Closed	27051700409600
Closed	00373000601701
Closed	00373000601702
Closed	00373000601602
Closed	00373000601603
Closed	30061100104300
Closed	00394507100802
Closed	00513700005417
Closed	00512200004200
Closed	28082100302300
Closed	01086000001200
Closed	01086000001600
Closed	01086000002000
Closed	01086000002700
Closed	01086000002300
Closed	01086000004000
Closed	01086000004500
Closed	01086000005500
Closed	01086000006000

Accessory Dwelling Units

Index # - File Name: 1.0022 - Single Family Dwellings Data\_Snohomish County.pdf

Closed	01086000006200
Closed	01073700000300
Closed	01073700000400
Closed	01073700000500
Closed	01073700000600
Closed	01073700000700
Closed	01073700000800
Closed	01073700000900
Closed	01073700001000
Closed	01073700001100
Closed	01073700001200
Closed	01073700001300
Closed	01073700001400
Closed	01074900000200
Closed	01073700001600
Closed	01073700001700
Closed	01073700001800
Closed	01073700001900
Closed	01073700002000
Closed	01073700002200
Closed	00394404102300
Closed	27071000401200
Closed	01078500006900
Closed	01078500007000
Closed	01078600000100
Closed	01078600000200
Closed	01078600000300
Closed	01078600000400
Closed	01078600000500
Closed	01078600000600
Closed	01078600000700
Closed	01078600000800
Closed	01078600000900
Closed	01078700000700
Closed	01078700000300
Closed	31063500203200
Closed	00574100006202
Closed	00853400000405
Closed	00394406201302
Closed	01075200000100
Closed	01075200000200
Closed	01075200000700
Closed	01075200001000
Closed	01075100000300
Closed	01075100000400
Closed	01075100000500
Closed	01075100000800

Accessory Dwelling Units

Index # - File Name: 1.0022 - Single Family Dwellings Data\_Snohomish County.pdf

Closed	01091800005000
Closed	01091800005100
Closed	01091800005200
Closed	01091800005300
Closed	01091800005400
Closed	01091800005500
Closed	00520200010100
Closed	00574100005802
Closed	01091800009000
Closed	01091800009100
Closed	01091800009600
Closed	01091800009700
Closed	01080300002400
Closed	01080300002500
Closed	01080300002600
Closed	01080300002700
Closed	01080300002800
Closed	01080300002900
Closed	01080300003000
Closed	28052200300700
Closed	32042500201600
Closed	32042500201500
Closed	00489200000800
Closed	32042500201400
Closed	01074200000200
Closed	01074200000700
Closed	01074200001000
Closed	01074200001100
Closed	01074200001500
Closed	00597300000804
Closed	01081200000200
Closed	01081200000700
Closed	00557200404600
Closed	28060200100100
Closed	30062200202500
Closed	30062200202600
Closed	31053400400600
Closed	28070800200100
Closed	00394403503000
Closed	00542000001000
Closed	00542000001000
Closed	00542000001000
Closed	00542000001000
Closed	32063300402800
Closed	29070900301900
Closed	27072900100700
Closed	28052100202900

Accessory Dwelling Units

Index # - File Name: 1.0022 - Single Family Dwellings Data\_Snohomish County.pdf

Closed	00512000212600
Closed	01095700000500
Closed	01095700000900
Closed	01095700001000
Closed	01095700001100
Closed	01096500000100
Closed	01096500000200
Closed	01096500000300
Closed	01096500000400
Closed	01096500000500
Closed	01097400000300
Closed	01097400000400
Closed	29070900100900
Closed	00486200000600
Closed	00556600011200
Closed	00373700401004
Closed	01097400003000
Closed	00461000600802
Closed	00461000600802
Closed	00461000600802
Closed	00461000600802
Closed	00556900003000
Closed	01109600000100
Closed	01109600000200
Closed	01109600000300
Closed	01109600000400
Closed	01109600000500
Closed	01109600000600
Closed	01109600000700
Closed	01109600000800
Closed	01109600000900
Closed	01109600001000
Closed	01109600001100
Closed	01109600001200
Closed	01109600001300
Closed	01109600001400
Closed	01109600001500
Closed	01109600001600
Closed	01109600001700
Closed	01109600001800
Closed	01109600001900
Closed	01109600002000
Closed	01109600002100
Closed	01109600002200
Closed	01109600002300
Closed	01109600002400
Closed	00461000600802

Accessory Dwelling Units

Index # - File Name: 1.0022 - Single Family Dwellings Data\_Snohomish County.pdf

Closed	01109600002500
Closed	01109600002600
Closed	01109600002700
Closed	01109600002800
Closed	01109600002900
Closed	01109600003100
Closed	01109600003200
Closed	01109600003300
Closed	01109600003400
Closed	01109600003500
Closed	01109600003600
Closed	01109600003700
Closed	01109600003800
Closed	01109600003900
Closed	01109600004000
Closed	01109600004400
Closed	01095500010700
Closed	01095500004100
Closed	01095500004500
Closed	01100100000300
Closed	01100100000100
Closed	01095500004200
Closed	01095500004300
Closed	01095500004400
Closed	01095500004600
Closed	01095500004700
Closed	01095500004800
Closed	30062800101800
Closed	01095500010800
Closed	01095500010900
Closed	00467100004900
Closed	00401000003900
Closed	28073300400400
Closed	27052100306100
Closed	01103300000200
Closed	01103300000800
Closed	00394402403900
Closed	30061800401100
Closed	01106200000300
Closed	01101800004900
Closed	01103500000400
Closed	01103500001200
Closed	01103500001400
Closed	29062600400200
Closed	01109000000100
Closed	28073400303800
Closed	01112500000400

Accessory Dwelling Units

Index # - File Name: 1.0022 - Single Family Dwellings Data\_Snohomish County.pdf

Closed	0111250000600
Closed	0111250000700
Closed	0111250001000
Closed	0111250001100
Closed	0111250001200
Closed	0108470000100
Closed	0108110000100
Closed	0108110000200
Closed	0108110000300
Closed	0108110000400
Closed	0040100004800
Closed	0037500006301
Closed	0037500006302
Closed	0108780000100
Closed	0108780000200
Closed	0108780000300
Closed	0108780000400
Closed	0108780000500
Closed	0045460000600
Closed	0108120000300
Closed	01079500002700
Closed	01079500002900
Closed	0108120000500
Closed	0108120001400
Closed	0108120001600
Closed	01079500002400
Closed	01079500003100
Closed	0110440000400
Closed	0110440000900
Closed	0110440001200
Closed	0110440001300
Closed	0110440001400
Closed	0110440001500
Closed	0110440001600
Closed	01079500001400
Closed	01079500001500
Closed	01079500001600
Closed	01079500001700
Closed	01079500001800
Closed	0107420000100
Closed	27062700201800
Closed	0108030000200
Closed	0108030000700
Closed	0108030001500
Closed	0108030001200
Closed	0108030001300
Closed	0108030002200



Accessory Dwelling Units

Index # - File Name: 1.0022 - Single Family Dwellings Data\_Snohomish County.pdf

Closed	01075100001000
Closed	01075100001100
Closed	01079400001100
Closed	01091800003800
Closed	01091800003900
Closed	01091800004000
Closed	01091800004100
Closed	01091800005600
Closed	01091800005700
Closed	01091800005800
Closed	01091800005900
Closed	01091800006000
Closed	01091800006100
Closed	01091800006200
Closed	01091800006300
Closed	01091800006400
Closed	01091800006500
Closed	01091800006600
Closed	01091800006700
Closed	29062300303200
Closed	01075100000200
Closed	01075100000100
Closed	01075200000400
Closed	32090800302200
Closed	00394406201303
Closed	01078700000800
Closed	01078700002000
Closed	01078700001200
Closed	01078600001800
Closed	01078600004000
Closed	01072900000300
Closed	01086000004400
Closed	00373701300116
Closed	01078500005700
Closed	01078500005800
Closed	01078500005900
Closed	01078500006000
Closed	01078500006100
Closed	01078500006200
Closed	01078500006800
Closed	01078600004600
Closed	01073700000100
Closed	01073700000200
Closed	00373701300111
Closed	00373701300112
Closed	00373701300113
Closed	01073700002100

Accessory Dwelling Units

Index # - File Name: 1.0022 - Single Family Dwellings Data\_Snohomish County.pdf

Closed	01073700001500
Closed	01086000006300
Closed	01086000006100
Closed	01086000005600
Closed	01086000005700
Closed	01086000005800
Closed	01086000005900
Closed	01086000004600
Closed	01086000004700
Closed	01086000004900
Closed	01086000005000
Closed	01086000005100
Closed	01086000005200
Closed	01086000005300
Closed	01086000005400
Closed	01086000003300
Closed	01086000002400
Closed	01086000002600
Closed	01086000003100
Closed	01086000002100
Closed	01086000002200
Closed	01086000001900
Closed	01086000001300
Closed	01086000001400
Closed	01086000000100
Closed	01086000000700
Closed	01086000000800
Closed	01086000000900
Closed	01086000001000
Closed	01086000001100
Closed	01075600004500
Closed	01075600004600
Closed	01075600004700
Closed	01075600004800
Closed	01086600000100
Closed	01086600000300
Closed	01086600000400
Closed	01086600000500
Closed	27061900405600
Closed	01090300001600
Closed	01106100000100
Closed	01106100000200
Closed	01106100000300
Closed	01106100000400
Closed	01106100000500
Closed	01106100000600
Closed	01086600001300

Accessory Dwelling Units

Index # - File Name: 1.0022 - Single Family Dwellings Data\_Snohomish County.pdf

Closed	01086600001400
Closed	01086600001500
Closed	01086600001600
Closed	01086600001700
Closed	01090300001400
Closed	01090300010000
Closed	01090300010100
Closed	01090300010300
Closed	01090300010400
Closed	27051700409500
Closed	01065000000100
Closed	01065000000200
Closed	01065000000300
Closed	01065000000400
Closed	01065000000500
Closed	01086100000400
Closed	01086100000600
Closed	00509200200803
Closed	00597400001703
Closed	32061900200600
Closed	00527000001505
Closed	00509500001904
Closed	01086700000700
Closed	01086700000800
Closed	01086700000900
Closed	01086700001000
Closed	01086700001100
Closed	01086700001200
Closed	01086700001300
Closed	01086700001400
Closed	01086700001500
Closed	27071100301600
Closed	00532100005003
Closed	32050700302800
Closed	01081400002900
Closed	01081400003000
Closed	01081400000100
Closed	01084700003500
Closed	01084700003800
Closed	01084700003900
Closed	01084700004000
Closed	01084700004100
Closed	01084700004200
Closed	01084700004300
Closed	01084700004500
Closed	01084700004600
Closed	31061600300100

Accessory Dwelling Units

Index # - File Name: 1.0022 - Single Family Dwellings Data\_Snohomish County.pdf

Closed	00556600007500
Closed	01084700002600
Closed	01084700002700
Closed	31041400301800
Closed	01084700005100
Closed	01084700005200
Closed	01084700005300
Closed	01084700005400
Closed	01084700005500
Closed	01084700005600
Closed	01084700005800
Closed	01084700005900
Closed	01084700006000
Closed	01084700006100
Closed	01084700006500
Closed	00532100004802
Closed	00532100004803
Closed	01084700000200
Closed	01084700002900
Closed	01084700003000
Closed	01084700003100
Closed	01084700003200
Closed	00403800801901
Closed	01081100001300
Closed	01084700000500
Closed	01084700000600
Closed	01084700000700
Closed	01084700000800
Closed	01093300008800
Closed	29070500202400
Closed	29070500202500
Closed	29070500202600
Closed	31042100400100
Closed	32100800101700
Closed	00608100100306
Closed	01093300006500
Closed	01093300006600
Closed	01087900000600
Closed	01088100000800
Closed	01088100000900
Closed	01088100001000
Closed	01088100001100
Closed	01088100001200
Closed	01088100001300
Closed	01088100001400
Closed	01088100001500
Closed	32060300302300

Accessory Dwelling Units

Index # - File Name: 1.0022 - Single Family Dwellings Data\_Snohomish County.pdf

Closed	28071800303000
Closed	29063000105800
Closed	01088000000100
Closed	01088000002400
Closed	01088000002500
Closed	01090000000400
Closed	01090000000500
Closed	00373701700902
Closed	00373701700902
Closed	00373701700902
Closed	00373701700902
Closed	00373701700902
Closed	00373701700902
Closed	00373701700902
Closed	00373701700902
Closed	01090100000100
Closed	01090100000300
Closed	01090100000400
Closed	01090100000500
Closed	01090100000600
Closed	01090100000700
Closed	01090100000800
Closed	01090100000900
Closed	01090100001000
Closed	01090100001100
Closed	01090100001200
Closed	01090100001300
Closed	28060300300900
Closed	32043200400600
Closed	29063000106300
Closed	29063000106400
Closed	00480000010000
Closed	00570400300801
Closed	00570400300802
Closed	00570400300803
Closed	00570400300804
Closed	01079700000500
Closed	32101800100300
Closed	01048000003900
Closed	01048000003000
Closed	01048000003600
Closed	01048000003300
Closed	01048000003400
Closed	01048000004300
Closed	01048000004400
Closed	01048000004500
Closed	01048000004600

Accessory Dwelling Units

Index # - File Name: 1.0022 - Single Family Dwellings Data\_Snohomish County.pdf

Closed	0104800000300
Closed	0104800000400
Closed	0104800000500
Closed	0104800000600
Closed	0104800000700
Closed	0104800001800
Closed	0104800001900
Closed	0104800002000
Closed	0104800002100
Closed	0104800002200
Closed	0104800002300
Closed	0104800002500
Closed	0104800002600
Closed	0104800002700
Closed	0104800001100
Closed	0104800001200
Closed	0104800001400
Closed	0104800001500
Closed	0104800001600
Closed	0104800007000
Closed	0104800005400
Closed	01048000010600
Closed	01048000010900
Closed	01048000011000
Closed	01053000001501
Closed	32050900401400
Closed	01048200001000
Closed	01048200001100
Closed	27040200300400
Closed	27040200300400
Closed	27040200300400
Closed	27040200300400
Closed	27040200300400
Closed	27040200300400
Closed	27040200300400
Closed	27040200300400
Closed	27040200300400
Closed	00373000300501
Closed	00556600003600
Closed	00466200010500
Closed	01049700000100
Closed	01049700001000
Closed	01049700001100
Closed	01049700002100
Closed	01049700002200
Closed	01049700000700
Closed	01049700000800

Accessory Dwelling Units

Index # - File Name: 1.0022 - Single Family Dwellings Data\_Snohomish County.pdf

Closed	01049700000300
Closed	01049700000400
Closed	01049700000500
Closed	01049700001600
Closed	01049700001700
Closed	01049700008300
Closed	01049700008800
Closed	01049700009300
Closed	01058000007800
Closed	01058000007900
Closed	31060600403600
Closed	01049700009000
Closed	01067900002500
Closed	01067900002700
Closed	01067900001500
Closed	01067900001700
Closed	01067900001800
Closed	01067900000500
Closed	01067900000600
Closed	01052700001400
Closed	01052700002000
Closed	01052700002100
Closed	01052700002200
Closed	01052700002300
Closed	01052700002400
Closed	01052700000200
Closed	01052700000300
Closed	01052700000400
Closed	01052700001700
Closed	01052700001800
Closed	29070400100300
Closed	01089100002701
Closed	01089100003701
Closed	28062300403100
Closed	01057200004100
Closed	01057200007100
Closed	01057200007200
Closed	01057200004400
Closed	01057200005500
Closed	01057200005600
Closed	01057200006600
Closed	01057200004900
Closed	01054700003400
Closed	01054700003500
Closed	01054700004200
Closed	31062000200100
Closed	01054700000100

Accessory Dwelling Units

Index # - File Name: 1.0022 - Single Family Dwellings Data\_Snohomish County.pdf

Closed	00557100101600
Closed	00557100101700
Closed	01054700000300
Closed	01064800000300
Closed	01075600000100
Closed	01075600000200
Closed	01075600000300
Closed	01075600000400
Closed	01075600001200
Closed	01095800001300
Closed	01072500000300
Closed	01075000000600
Closed	01075700000100
Closed	01075700000500
Closed	01075700000800
Closed	01075000000100
Closed	01072400000500
Closed	01072400000900
Closed	01072800000200
Closed	00376800004903
Closed	01075900009300
Closed	01075900007400
Closed	01075900006100
Closed	01047500000800
Closed	01047500001600
Closed	01047500001700
Closed	01047500000300
Closed	01069200002300
Closed	01069200003800
Closed	01069200003900
Closed	01069200004000
Closed	01069200002500
Closed	01069200002600
Closed	32042800102200
Closed	32063600203200
Closed	28051700411800
Closed	01066200000800
Closed	01083900000100
Closed	01083900000200
Closed	01083900000900
Closed	01083900001000
Closed	01068700002700
Closed	01083900000400
Closed	01068700007900
Closed	01068700003000
Closed	01068700003100
Closed	01068700002200



Accessory Dwelling Units

Index # - File Name: 1.0022 - Single Family Dwellings Data\_Snohomish County.pdf

Closed	01068700001700
Closed	01068700001800
Closed	01068700001900
Closed	01068700002000
Closed	01068700001500
Closed	01061500003600
Closed	01061500004100
Closed	01061500004200
Closed	01068700001200
Closed	01061500003900
Closed	01061500002600
Closed	01061500000700
Closed	01061500000800
Closed	01061500000900
Closed	01061500001000
Closed	01061500000100
Closed	01061500000200
Closed	01061500000300
Closed	01061500000400
Closed	01061500000500
Closed	01059100001000
Closed	01059100000100
Closed	01059100001300
Closed	32041400100300
Closed	01064400003600
Closed	01064400001800
Closed	01064400001400
Closed	01064400001500
Closed	01064400001600
Closed	32042500201700
Closed	01064400000100
Closed	01064400000200
Closed	01064400000300
Closed	01064400000400
Closed	01064400000500
Closed	01064400000600
Closed	01064400000700
Closed	01064400000800
Closed	01064400000900
Closed	01064400001000
Closed	01061600001000
Closed	01061600001100
Closed	01061600001200
Closed	01061600001300
Closed	01061600001400
Closed	01061600001500
Closed	01061600001600

Accessory Dwelling Units

Index # - File Name: 1.0022 - Single Family Dwellings Data\_Snohomish County.pdf

Closed	01061600001700
Closed	01061600001800
Closed	01061600001900
Closed	01061600002000
Closed	01061600002100
Closed	01061600002200
Closed	01061600002300
Closed	01061600000400
Closed	01061600000500
Closed	01061600000600
Closed	01061600000700
Closed	01061600000200
Closed	01064900001600
Closed	01064900001700
Closed	01064900001800
Closed	01064900001900
Closed	01063500006300
Closed	01063500006400
Closed	01063500006600
Closed	01063500006000
Closed	01063500006100
Closed	01063500005400
Closed	01063500005500
Closed	01063500005100
Closed	01063500005200
Closed	01063500004700
Closed	01063500008800
Closed	01063500008900
Closed	01063500004100
Closed	01063500003600
Closed	01063500003700
Closed	01063500003800
Closed	01063500003100
Closed	01063500003200
Closed	01063500003300
Closed	01063500003400
Closed	01063500002200
Closed	01071900001100
Closed	01071900000600
Closed	31041400402300
Closed	01064400004800
Closed	01064400004900
Closed	01064400005100
Closed	01064400005200
Closed	01064400005300
Closed	01064400005400
Closed	01095300000800

Accessory Dwelling Units

Index # - File Name: 1.0022 - Single Family Dwellings Data\_Snohomish County.pdf

Closed	01095300001000
Closed	01095300001600
Closed	01095300001700
Closed	01095300001800
Closed	01095300000300
Closed	01057800003000
Closed	01063500008100
Closed	01063500008200
Closed	01063500008300
Closed	01063500008600
Closed	00373100500211
Closed	00373100500212
Closed	01063200000900
Closed	00480401501300
Closed	00480401601300
Closed	01057800003300
Closed	01010100003300
Closed	27071800401800
Closed	01018600003600
Closed	01000100001400
Closed	01000100001500
Closed	01000100001600
Closed	01000100001700
Closed	01000100001800
Closed	01000100001900
Closed	01000100002000
Closed	01000100002100
Closed	01000100002200
Closed	01000100002300
Closed	01000100000200
Closed	01000100000300
Closed	01000100000400
Closed	01000100000600
Closed	01000100000700
Closed	00931400000600
Closed	00933300001600
Closed	27071900402500
Closed	00525500001101
Closed	27062400100700
Closed	01054400000500
Closed	01054400001100
Closed	01054400001400
Closed	01054400001500
Closed	01054400001600
Closed	01054400001800
Closed	32051300302300
Closed	01054400000700

Accessory Dwelling Units

Index # - File Name: 1.0022 - Single Family Dwellings Data\_Snohomish County.pdf

Closed	01041300000400
Closed	01041300002200
Closed	32041300403100
Closed	01054400003700
Closed	01041300003000
Closed	01043600007200
Closed	01043600006500
Closed	01043600006600
Closed	29063300201300
Closed	01043600000300
Closed	01043600000700
Closed	01043600000800
Closed	01043600000900
Closed	01043600001000
Closed	01043600007300
Closed	01042000006900
Closed	01043800101200
Closed	01043800101900
Closed	01043800103900
Closed	01043800104000
Closed	01043800104100
Closed	01043800103200
Closed	01043800102900
Closed	01043800102700
Closed	01043800103500
Closed	01043800104500
Closed	01043800105200
Closed	01043800105300
Closed	01043500001000
Closed	01040500002600
Closed	01040500002800
Closed	01040500001500
Closed	01040500000200
Closed	01040500000300
Closed	01040500002300
Closed	32042600202500
Closed	32060400400100
Closed	30061800102400
Closed	00394406100600
Closed	27070600103600
Closed	28050300401000
Closed	00494511300701
Closed	30072000400100
Closed	30040100200700
Closed	30050100103700
Closed	32052200103000
Closed	28062400402600

Accessory Dwelling Units

Index # - File Name: 1.0022 - Single Family Dwellings Data\_Snohomish County.pdf

Closed	01028600001800
Closed	00473300001627
Closed	01011500000300
Closed	28073200302600
Closed	01010100004400
Closed	00543300002000
Closed	01024300003700
Closed	01024300003800
Closed	29062900102900
Closed	01023800002900
Closed	01019100003200
Closed	01019100003300
Closed	01019100011200
Closed	00587200004300
Closed	00630600001300
Closed	29051400403600
Closed	29073400401000
Closed	00911300000900
Closed	00403800014904
Closed	28072800400200
Closed	00401100006200
Closed	27062100401600
Closed	29061600100200
Closed	27071200400900
Closed	27071800100100
Closed	00473300001603
Closed	00594300000803
Closed	31051700202000
Closed	00960007012800
Closed	00928500000700
Closed	00601600000202
Closed	00924300001200
Closed	00394403904100
Closed	32041500302500
Closed	32041500302600
Closed	00394401904300
Closed	31043500401700
Closed	29061000103500
Closed	30081500201400
Closed	27051700304900
Closed	00401100008000
Closed	32063500300700
Closed	27051100306400
Closed	00394405201000
Closed	27090900100900
Closed	27051900401200
Closed	27062100200800

Accessory Dwelling Units

Index # - File Name: 1.0022 - Single Family Dwellings Data\_Snohomish County.pdf

Closed	27062100301500
Closed	27051400305400
Closed	27051000300100
Closed	27070300101800
Closed	27063500302300
Closed	00372800203001
Closed	27103400101300
Closed	27062700403100
Closed	27062900202500
Closed	27052500102300
Closed	27062700202600
Closed	27062700200500
Closed	00403800007907
Closed	00428200000300
Closed	00430400000400
Closed	00430400000600
Closed	00452600200700
Closed	00623700005500
Closed	00634100001200
Closed	00634100002400
Closed	00623700000200
Closed	00464100001100
Closed	00509200102000
Closed	00506900001000
Closed	00506900001200
Closed	00526200609400
Closed	00526100507400
Closed	00542000000400
Closed	00513700005405
Closed	00379900000200
Closed	00379900000300
Closed	28083500402900
Closed	28083500407400
Closed	28083400402000
Closed	28083400402700
Closed	28063100301000
Closed	28072600102300
Closed	28072900302900
Closed	28072900400300
Closed	28082000401500
Closed	28072100401700
Closed	28082100200900
Closed	28072200200500
Closed	28061400300300
Closed	28071900301200
Closed	28051700400700
Closed	28072000200600

Accessory Dwelling Units

Index # - File Name: 1.0022 - Single Family Dwellings Data\_Snohomish County.pdf

Closed	28061100400100
Closed	28060300201000
Closed	28060100201300
Closed	28060400402100
Closed	28050100201500
Closed	00730000000400
Closed	00426800001201
Closed	00432700000800
Closed	00420500002400
Closed	00396500006800
Closed	00396500007000
Closed	00493900001800
Closed	00538000000304
Closed	00568900001300
Closed	00574200004500
Closed	00574100013200
Closed	00574100010100
Closed	00573800005300
Closed	00614800003700
Closed	00608100500302
Closed	29061400301100
Closed	00624300000600
Closed	29063400402200
Closed	29061900302500
Closed	29071600401200
Closed	29062100201500
Closed	29062400200400
Closed	30072000100100
Closed	30062000302200
Closed	30052100106200
Closed	30051600108100
Closed	30051200201100
Closed	30061300202300
Closed	30060300102200
Closed	00397700002800
Closed	00464400001100
Closed	00457100004105
Closed	00491900201600
Closed	00491900203000
Closed	00604800000802
Closed	00516700012100
Closed	30040200400200
Closed	00622300001701
Closed	00579800000403
Closed	00557100404100
Closed	00551400008000
Closed	00557100404000

Accessory Dwelling Units

Index # - File Name: 1.0022 - Single Family Dwellings Data\_Snohomish County.pdf

Closed	00557100404800
Closed	00557100101500
Closed	00557100301600
Closed	00557100301700
Closed	00511000006800
Closed	00548200002601
Closed	00495900004000
Closed	00478500002500
Closed	00480000009900
Closed	00385300008100
Closed	00401100001200
Closed	00401100006300
Closed	00401100006400
Closed	31051900102900
Closed	31051600200600
Closed	31042200404500
Closed	31060700400600
Closed	31060700100900
Closed	31063000402200
Closed	31052600204200
Closed	31053600401000
Closed	00384300003600
Closed	31063300100800
Closed	00480700000304
Closed	00482900000200
Closed	00394507000100
Closed	00394406600901
Closed	00394405801302
Closed	32052800200500
Closed	32052900103600
Closed	32053200301900
Closed	32063200201800
Closed	32052200401400
Closed	32061800101300
Closed	32080900201400
Closed	32051300300100
Closed	32040800202200
Closed	32040500402800
Closed	32050700201300
Closed	00494511801600
Closed	00489700301600
Closed	00489700302200
Closed	00490900003500
Closed	00579100004702
Closed	00546900001000
Closed	00494600300803
Closed	00498800100900



Accessory Dwelling Units

Index # - File Name: 1.0022 - Single Family Dwellings Data\_Snohomish County.pdf

Closed	31050100102700
Closed	00597500000302
Closed	29070500100300
Closed	00612500003500
Closed	00639500000500
Closed	00637400001000
Closed	30060700200300
Closed	00394406700300
Closed	31062700100500
Closed	32050900202800
Closed	00630600001400
Closed	30072000202900
Closed	29071800201200
Closed	00409500000902
Closed	00853600003900
Closed	00586900000702
Closed	32052000102600
Closed	28093100404000
Closed	32040800302200
Closed	00548200002407
Closed	00457100004102
Closed	32051800301100
Closed	29051400402600
Closed	30072000400300
Closed	30080900303500
Closed	27062000200100
Closed	00529100000600
Closed	00587200002000
Closed	30063500400200
Closed	28072800200100
Closed	30050600400800
Closed	32070800101400
Closed	00844300000400
Closed	32040800101100
Closed	30070500203500
Closed	00499100202600
Closed	00563100000601
Closed	32050900300900
Closed	32080200200600
Closed	00720900000900
Closed	32051200301100
Closed	32061500201200
Closed	32051900400300
Closed	32051900200400
Closed	32052200303200
Closed	32063200102100
Closed	32073000100200

Accessory Dwelling Units

Index # - File Name: 1.0022 - Single Family Dwellings Data\_Snohomish County.pdf

Closed	32072900300700
Closed	32052900400400
Closed	00394405001002
Closed	00394404300101
Closed	31062700301700
Closed	31041300302000
Closed	31040900201700
Closed	31042200202100
Closed	30052500400800
Closed	30052500401900
Closed	30063200201400
Closed	30063200401500
Closed	00520200003200
Closed	00551400005201
Closed	00579800000803
Closed	00582600102200
Closed	00629100000700
Closed	00597600000900
Closed	00476200100119
Closed	00492000204000
Closed	00470900001400
Closed	30040300401100
Closed	30040200402700
Closed	30061400301200
Closed	30061400200600
Closed	30061900103800
Closed	30062000300300
Closed	30071800203000
Closed	30042300200200
Closed	29062600101500
Closed	29071800200800
Closed	29063500203300
Closed	29063400201200
Closed	00666700000700
Closed	00704100000800
Closed	00762200001000
Closed	29060200301400
Closed	00420600000300
Closed	28060300201100
Closed	28071200301100
Closed	28061200300500
Closed	28070700300800
Closed	28070900401400
Closed	28071800303400
Closed	28072500200400
Closed	28072800401000
Closed	28063100300300

Accessory Dwelling Units

Index # - File Name: 1.0022 - Single Family Dwellings Data\_Snohomish County.pdf

Closed	28073000301700
Closed	28093200400500
Closed	28093200400500
Closed	28073400400700
Closed	28073300303000
Closed	00373300501301
Closed	00576800101900
Closed	00623700004500
Closed	00419500000101
Closed	00403900025806
Closed	00385200002700
Closed	00373003100303
Closed	00373700400704
Closed	27073000400100
Closed	27062700400800
Closed	27053400205000
Closed	00372801500501
Closed	00372800800909
Closed	00372801000202
Closed	27061800200500
Closed	27061700100300
Closed	27071900101700
Closed	29061300203200
Closed	00874900000300
Closed	31052500302500
Closed	28070500300500
Closed	31041000400500
Closed	32042200200800
Closed	27103400100300
Closed	29073200100500
Closed	29073200302100
Closed	30063400300500
Closed	00442100001400
Closed	01019100010600
Closed	01019100010700
Closed	01019100010800
Closed	01019100010900
Closed	01019100011000
Closed	01019100011100
Closed	01019100006100
Closed	01019100013500
Closed	01019100011800
Closed	01019100011900
Closed	01019100003400
Closed	01019100003500
Closed	01019100002600
Closed	01019100000100

Accessory Dwelling Units

Index # - File Name: 1.0022 - Single Family Dwellings Data\_Snohomish County.pdf

Closed	01019100000200
Closed	01019100000300
Closed	01019100000400
Closed	01019100000500
Closed	01019100000600
Closed	01019100000700
Closed	01019100000800
Closed	01019100000900
Closed	01019100001000
Closed	01019100001100
Closed	01019100001200
Closed	01019100001300
Closed	01019100001400
Closed	01019100001500
Closed	01019100001600
Closed	01019100001700
Closed	01019100001800
Closed	01019100001900
Closed	01025000001400
Closed	01025000001500
Closed	01025000001600
Closed	28073300203100
Closed	28070300100600
Closed	30061100401200
Closed	32042600202500
Closed	01035300003300
Closed	01040500002500
Closed	01042000005600
Closed	01042000005900
Closed	01042000006000
Closed	01042000006100
Closed	01042000006200
Closed	01042000006300
Closed	01042000006400
Closed	01042000006500
Closed	01042000006600
Closed	01042000006700
Closed	01042000006800
Closed	01043600000100
Closed	010436000006700
Closed	01042000001600
Closed	01042000001700
Closed	01042000001800
Closed	01042000001900
Closed	01042000003400
Closed	01042000003500
Closed	01042000003600

Accessory Dwelling Units

Index # - File Name: 1.0022 - Single Family Dwellings Data\_Snohomish County.pdf

Closed	01042000003700
Closed	01042000003800
Closed	01042000003900
Closed	01042000004000
Closed	01042000004100
Closed	01042000004200
Closed	01042000004300
Closed	01042000004400
Closed	01042000004500
Closed	01042000004600
Closed	01042000004700
Closed	01042000002200
Closed	01042000002300
Closed	01042000002400
Closed	28083600401500
Closed	32081000201800
Closed	01048500007100
Closed	31040500401000
Closed	32052200200300
Closed	32042600102100
Closed	00401100004000
Closed	01063500005000
Closed	01063500008700
Closed	01063500007900
Closed	01063500008000
Closed	01063500008400
Closed	01063500008500
Closed	01095300000400
Closed	01095300000500
Closed	01095300000600
Closed	01095300000700
Closed	01082500002100
Closed	01082500002200
Closed	01082500002300
Closed	01082500002400
Closed	01082500002500
Closed	01082500002600
Closed	01082500001200
Closed	01082500001300
Closed	01082500001400
Closed	01082500001500
Closed	01095300001200
Closed	01095300001400
Closed	01082500002900
Closed	01082500003000
Closed	01082500003100
Closed	01082500003200

Accessory Dwelling Units

Index # - File Name: 1.0022 - Single Family Dwellings Data\_Snohomish County.pdf

Closed	01082500003300
Closed	01082500003400
Closed	01082500003500
Closed	01082500003600
Closed	01082500003700
Closed	01082500003800
Closed	01082500003900
Closed	01082500004000
Closed	01082500004100
Closed	01082500004200
Closed	01082500004300
Closed	01082500004400
Closed	01082500004500
Closed	01082500004600
Closed	01082500004700
Closed	01095300000200
Closed	01082500000100
Closed	01082500000200
Closed	01082500000300
Closed	01082500000400
Closed	01082500000500
Closed	01082500000600
Closed	01082500000700
Closed	01082500000800
Closed	01082500000900
Closed	01082500001000
Closed	01064400005000
Closed	01058200000400
Closed	31041400402500
Closed	01071900001200
Closed	01063500002400
Closed	01063500002500
Closed	01063500002700
Closed	01063500002800
Closed	01063500002900
Closed	01063500003000
Closed	01063500003500
Closed	01063500000900
Closed	01063500001100
Closed	01063500001300
Closed	01063500001400
Closed	01063500001500
Closed	01075800000100
Closed	01075800000200
Closed	01075800000300
Closed	01075800000400
Closed	01075800000500

Accessory Dwelling Units

Index # - File Name: 1.0022 - Single Family Dwellings Data\_Snohomish County.pdf

Closed	01075800000600
Closed	01075800000700
Closed	01075800000800
Closed	01075800000900
Closed	01075800001000
Closed	01075800001100
Closed	01075800001200
Closed	01075800001300
Closed	01075800001400
Closed	01075800001500
Closed	01075800001600
Closed	01075800001700
Closed	01075800001800
Closed	01075800001900
Closed	01075800002000
Closed	01075800002100
Closed	01075800002200
Closed	01075800002300
Closed	01075800002400
Closed	01075800002500
Closed	01075800002600
Closed	01075800002700
Closed	01075800002800
Closed	01075800002900
Closed	01075800003000
Closed	01075800003100
Closed	01075800003200
Closed	01075800003300
Closed	01063500004800
Closed	01063500004500
Closed	01063500005700
Closed	01063500006700
Closed	01063500006500
Closed	01064400001100
Closed	01064400001200
Closed	01064400001300
Closed	01064400004700
Closed	27051800201800
Closed	01057700000200
Closed	01068700002300
Closed	01068700002400
Closed	01068700002500
Closed	01068700002600
Closed	01068700003200
Closed	01068700003300
Closed	01068700003400
Closed	01068700003500

Accessory Dwelling Units

Index # - File Name: 1.0022 - Single Family Dwellings Data\_Snohomish County.pdf

Closed	01068700003600
Closed	01068700003700
Closed	01068700003800
Closed	01068700003900
Closed	01068700004000
Closed	01068700004100
Closed	01068700004300
Closed	01068700004400
Closed	01068700004500
Closed	01068700004600
Closed	01083900000500
Closed	01083900000600
Closed	01083900000700
Closed	01083900000800
Closed	01068700002900
Closed	01083900001100
Closed	01083900001200
Closed	01083900000300
Closed	01066200003700
Closed	01066200003800
Closed	01066200003900
Closed	01066200004000
Closed	01066200004100
Closed	01066200002700
Closed	01066200002800
Closed	00373002300404
Closed	00420500000200
Closed	01063000001800
Closed	01066200004500
Closed	01066200004600
Closed	01066200004700
Closed	01068500000700
Closed	01066500001600
Closed	01066500000100
Closed	01066500001200
Closed	01066500001300
Closed	01066500000600
Closed	01066500000700
Closed	01069200002700
Closed	01069200002800
Closed	01069200003600
Closed	01069200003700
Closed	01069200000900
Closed	01069200001000
Closed	01069200001100
Closed	01069200001200
Closed	01069200004100



Accessory Dwelling Units

Index # - File Name: 1.0022 - Single Family Dwellings Data\_Snohomish County.pdf

Closed	01069200004200
Closed	01069200004400
Closed	01069200004500
Closed	01069200004600
Closed	27061600400300
Closed	01069200003000
Closed	01069200003100
Closed	01047500001800
Closed	01047500001900
Closed	01047500002000
Closed	01047500002100
Closed	01047500002200
Closed	01047500002800
Closed	01047500002900
Closed	01068600000200
Closed	01068600000300
Closed	01068600000800
Closed	01075900000100
Closed	01075900000200
Closed	01075900000300
Closed	01075900000400
Closed	01075900000500
Closed	01075900000600
Closed	01075900002900
Closed	01075900003200
Closed	01075900003600
Closed	01075900003700
Closed	01075900003800
Closed	01075900003900
Closed	01075900004000
Closed	01075900004100
Closed	01075900004200
Closed	01075900004300
Closed	01075900004400
Closed	01075900004500
Closed	01075900004600
Closed	01075900004700
Closed	01075900004800
Closed	01075900004900
Closed	01075900005000
Closed	01075900005100
Closed	01075900005200
Closed	01075900005300
Closed	01075900005400
Closed	01075900005500
Closed	01075900005600
Closed	01075900005700

Accessory Dwelling Units

Index # - File Name: 1.0022 - Single Family Dwellings Data\_Snohomish County.pdf

Closed	01075900005800
Closed	01075900005900
Closed	01075900006000
Closed	01075900006200
Closed	01075900006300
Closed	01075900006400
Closed	01075900006500
Closed	01075900006600
Closed	01075900006700
Closed	01075900006800
Closed	01075900006900
Closed	01075900007000
Closed	01075900007500
Closed	01075900007600
Closed	01075900007700
Closed	01075900007800
Closed	01075900007900
Closed	01075900007300
Closed	01068600001100
Closed	01075900008100
Closed	01072400000400
Closed	01095800000800
Closed	01095800000900
Closed	01095800001000
Closed	01095800001100
Closed	01095800001800
Closed	01095800002100
Closed	01095800002900
Closed	01095800003000
Closed	28060300400300
Closed	00562800006102
Closed	00562800006103
Closed	01054700007300
Closed	01054700007400
Closed	01057200005000
Closed	01057200006000
Closed	01057200006100
Closed	01057200006200
Closed	01057200006300
Closed	01057200005200
Closed	01057200001300
Closed	27062000403900
Closed	28052200303900
Closed	28052200304200
Closed	01052700004000
Closed	01052700002500
Closed	01058000011000

Accessory Dwelling Units

Index # - File Name: 1.0022 - Single Family Dwellings Data\_Snohomish County.pdf

Closed	01058000011800
Closed	01058000010400
Closed	01058000010500
Closed	01058000010600
Closed	01058000010700
Closed	01058000012000
Closed	01058000012100
Closed	01058000012300
Closed	01058000012400
Closed	01058000009900
Closed	01049700010100
Closed	01049700009900
Closed	01049700010500
Closed	01049700008900
Closed	01049700008400
Closed	01049700008500
Closed	01058000005600
Closed	01058000005700
Closed	01058000004900
Closed	01058000005000
Closed	01058000004200
Closed	01058000004300
Closed	01058000004400
Closed	01058000004500
Closed	01049700001800
Closed	01049700001900
Closed	01049700002000
Closed	01049700000200
Closed	31040500102400
Closed	01053400001900
Closed	01053400002000
Closed	01053400002200
Closed	01053000001200
Closed	01053000001300
Closed	01053000000100
Closed	01053000000200
Closed	01053000000300
Closed	01048000007100
Closed	01048000008100
Closed	01048000001300
Closed	01048000001000
Closed	00493300200801
Closed	01048000004100
Closed	01079700000900
Closed	28050200203300
Closed	01090000000300
Closed	00374100101407

Accessory Dwelling Units

Index # - File Name: 1.0022 - Single Family Dwellings Data\_Snohomish County.pdf

Closed	01088100000100
Closed	01093300006700
Closed	01093300006800
Closed	01093300006900
Closed	01093300007000
Closed	01093300007100
Closed	01093300007200
Closed	01093300007300
Closed	01093300007400
Closed	01093300007500
Closed	01093300007600
Closed	01093300007700
Closed	01093300007800
Closed	01093300007900
Closed	01093300008000
Closed	01093300008100
Closed	01093300008200
Closed	01093300008300
Closed	01093300008400
Closed	01093300008500
Closed	01093300008600
Closed	01093300008700
Closed	01093300004200
Closed	01093300004300
Closed	01093300004400
Closed	01093300004500
Closed	01093300004600
Closed	01093300004700
Closed	01093300004800
Closed	01093300004900
Closed	01093300005000
Closed	01093300005100
Closed	00466200002700
Closed	01093300000100
Closed	01093300000200
Closed	01093300008900
Closed	01093300009000
Closed	01093300010700
Closed	01093300010800
Closed	01093300010900
Closed	01093300011000
Closed	01084700000900
Closed	01084700001000
Closed	01084700001100
Closed	01084700001200
Closed	01084700001300
Closed	01084700001400

Accessory Dwelling Units

Index # - File Name: 1.0022 - Single Family Dwellings Data\_Snohomish County.pdf

Closed	01084700001500
Closed	01084700001600
Closed	01084700001700
Closed	01084700001800
Closed	01084700001900
Closed	01084700002000
Closed	01084700002100
Closed	01084700002200
Closed	01084700002300
Closed	01084700002400
Closed	01084700002500
Closed	00538000013907
Closed	01084700000300
Closed	01084700000400
Closed	01084700006600
Closed	01084700006900
Closed	01084700007000
Closed	01084700007100
Closed	01084700007200
Closed	01084700002800
Closed	01109200000900
Closed	00483000000100
Closed	31060600203300
Closed	01109200000100
Closed	01109200000300
Closed	01109200000400
Closed	01109200000500
Closed	01081400002000
Closed	01081400002400
Closed	01081400001500
Closed	01081400000900
Closed	01081400001000
Closed	01081400003100
Closed	00527000001504
Closed	01086700001600
Closed	01086700001700
Closed	00403900020702
Closed	01086700000600
Closed	00604100001206
Closed	01090300010200
Closed	01090300001500
Closed	01087700000400
Closed	01087700000500
Closed	01087700000600
Closed	01087900000200
Closed	01087900000300
Closed	27063300102700

Accessory Dwelling Units

Index # - File Name: 1.0022 - Single Family Dwellings Data\_Snohomish County.pdf

Closed	01090300005400
Closed	01090300005500
Closed	01090300005600
Closed	01090300005700
Closed	01090300006100
Closed	00373003100406
Closed	01095800002600
Closed	00614800003600
Closed	00614800003500
Closed	01075600004200
Closed	01075600004300
Closed	01075600004400
Closed	01086000003200
Closed	01086000002800
Closed	01086000002900
Closed	01086000003000
Closed	01086000003400
Closed	01086000003500
Closed	01086000003600
Closed	01086000003700
Closed	01086000003800
Closed	01086000003900
Closed	01086000004100
Closed	32080200100400
Closed	01078600004700
Closed	01078600004800
Closed	01078600005000
Closed	01078600005100
Closed	01078600007600
Closed	01078600007700
Closed	01078600007800
Closed	01078600007900
Closed	01078600008000
Closed	01078600008100
Closed	01078600008200
Closed	01078600008300
Closed	01078600008400
Closed	01078600008500
Closed	01078600008600
Closed	01078600008700
Closed	01078500002500
Closed	01078600001000
Closed	01078600004500
Closed	01078600002800
Closed	01078600003100
Closed	01078600003200
Closed	01078600002000

Accessory Dwelling Units

Index # - File Name: 1.0022 - Single Family Dwellings Data\_Snohomish County.pdf

Closed	01078600002300
Closed	01078600002400
Closed	01078600002500
Closed	01078600002600
Closed	01078700001300
Closed	01078700001400
Closed	01078700001500
Closed	01078700001600
Closed	01078700001700
Closed	01078700001800
Closed	01078700001900
Closed	01078700002100
Closed	01078700002200
Closed	01078700000900
Closed	01078700001000
Closed	01078700001100
Closed	01078700002400
Closed	01078700002500
Closed	01078700002600
Closed	01078700002700
Closed	28072000203100
Closed	01075100000900
Closed	01075100000600
Closed	01075100000700
Closed	01091800007400
Closed	01091800007500
Closed	01091800007600
Closed	01091800007700
Closed	01091800007800
Closed	01091800007900
Closed	01091800008000
Closed	01091800002200
Closed	01091800002300
Closed	01091800002400
Closed	01091800002500
Closed	01091800002600
Closed	01091800002700
Closed	01091800002800
Closed	01091800002900
Closed	01091800003000
Closed	01091800003100
Closed	01091800003200
Closed	01091800003300
Closed	01091800003400
Closed	01091800003500
Closed	01091800003600
Closed	01091800003700

Accessory Dwelling Units

Index # - File Name: 1.0022 - Single Family Dwellings Data\_Snohomish County.pdf

Closed	01091800004200
Closed	01091800004300
Closed	01091800004400
Closed	01091800004500
Closed	01091800004600
Closed	01091800004700
Closed	01091800004800
Closed	01091800004900
Closed	01091800009200
Closed	01091800009300
Closed	01091800009400
Closed	01091800009500
Closed	01079400001200
Closed	01075100001200
Closed	01079400000100
Closed	01079400000200
Closed	01080300002300
Closed	01080300001400
Closed	01080300001600
Closed	01080300000800
Closed	01080300000300
Closed	01080300000400
Closed	01080300000500
Closed	01080300000600
Closed	01080300000100
Closed	01074200001300
Closed	01074200000900
Closed	00509500001009
Closed	01087800000600
Closed	01087800000700
Closed	01087800000800
Closed	01087800000900
Closed	01087800001000
Closed	01081100000800
Closed	01098800000100
Closed	01098800000200
Closed	01098800000300
Closed	01098800000400
Closed	01098800000500
Closed	01098800000600
Closed	01098800000700
Closed	01098800000800
Closed	01098800000900
Closed	01098800001000
Closed	01098800001100
Closed	01098800001200
Closed	01098800001300



Accessory Dwelling Units

Index # - File Name: 1.0022 - Single Family Dwellings Data\_Snohomish County.pdf

Closed	01098800001400
Closed	01098800001500
Closed	01098800001600
Closed	01098800001700
Closed	01098800001900
Closed	01098800002000
Closed	01098800002100
Closed	01098800002200
Closed	01112500000100
Closed	01112500000200
Closed	01112500000300
Closed	00508900001815
Closed	31060500203700
Closed	00508900001801
Closed	00394404701400
Closed	01110700000200
Closed	01110700000300
Closed	01110700000400
Closed	01110700000500
Closed	01110700000600
Closed	01110700000700
Closed	01110700000800
Closed	01110700000900
Closed	01110700001000
Closed	01110700001100
Closed	01110700001200
Closed	01110700001300
Closed	01110700001400
Closed	01110700001500
Closed	01110700001600
Closed	01110700001700
Closed	01110700001800
Closed	01110700001900
Closed	01110700002000
Closed	01110700002100
Closed	01110700002200
Closed	01110700002300
Closed	01110300000100
Closed	01110300000200
Closed	01110300000300
Closed	01110300000400
Closed	01110300000800
Closed	01110300000900
Closed	01110300001100
Closed	01110300001200
Closed	01110300001300
Closed	01110300001600

Accessory Dwelling Units

Index # - File Name: 1.0022 - Single Family Dwellings Data\_Snohomish County.pdf

Closed	01110300001800
Closed	01110300001900
Closed	01109000000200
Closed	01109000000300
Closed	01109000000600
Closed	01111300000600
Closed	01111300000700
Closed	01111300003000
Closed	01111300003100
Closed	01111300000300
Closed	01111300000400
Closed	01108100001200
Closed	01108100000800
Closed	01108100002500
Closed	01108100002700
Closed	01108100002900
Closed	30040300300600
Closed	01108100003100
Closed	01114700000500
Closed	01114700000600
Closed	00466200009700
Closed	00375000005304
Closed	29052300403700
Closed	29052300403600
Closed	29052300403500
Closed	29052300402900
Closed	29052300403000
Closed	01112200000100
Closed	01112200000200
Closed	01112200000900
Closed	01112200001000
Closed	01112200001500
Closed	01112200001600
Closed	01112200001700
Closed	01112200001800
Closed	01110500001400
Closed	01112200000400
Closed	01112200002200
Closed	01112200002300
Closed	01112200002400
Closed	29052300401800
Closed	29052300402300
Closed	29052300402400
Closed	29052300402500
Closed	29052300402600
Closed	29052300402700
Closed	29052300402800

Accessory Dwelling Units

Index # - File Name: 1.0022 - Single Family Dwellings Data\_Snohomish County.pdf

Closed	00374100100711
Closed	01114700000300
Closed	01114700002100
Closed	01114700002300
Closed	01114700002600
Closed	32051800202600
Closed	00431301200402
Closed	00431301200102
Closed	00431301200403
Closed	32090800302400
Closed	01110500001100
Closed	01110500001900
Closed	32042700203500
Closed	31060500203400
Closed	29071800301500
Closed	01101800004700
Closed	01101800004300
Closed	01101800004400
Closed	01101800004500
Closed	01101800005300
Closed	01101800005500
Closed	01101800005600
Closed	01101800005100
Closed	01101800003800
Closed	01101800003900
Closed	01101800004000
Closed	01101800000500
Closed	01101800002300
Closed	01098900000100
Closed	01103300000900
Closed	01103300001000
Closed	01103300000300
Closed	01103300000400
Closed	01103300000500
Closed	01103300000600
Closed	01103300000700
Closed	01103300000100
Closed	01098700000100
Closed	01098700000200
Closed	01098700000400
Closed	01098700000600
Closed	01098700000800
Closed	01098700001600
Closed	01098700002200
Closed	01098700002300
Closed	01095500003000
Closed	01095500003100

Accessory Dwelling Units

Index # - File Name: 1.0022 - Single Family Dwellings Data\_Snohomish County.pdf

Closed	01095500003200
Closed	01095500009700
Closed	01095500009800
Closed	01095500010000
Closed	01095500010100
Closed	01095500010200
Closed	01095500010400
Closed	01095500010500
Closed	01095500010600
Closed	01095500000600
Closed	01095500000700
Closed	01095500000800
Closed	01095500001400
Closed	01095500001500
Closed	01095500001600
Closed	01095500006600
Closed	01095500006700
Closed	01095500006800
Closed	01095500007000
Closed	01095500007100
Closed	01095500007200
Closed	01095500007400
Closed	01095500007500
Closed	01095500007600
Closed	01100100000400
Closed	01100100000500
Closed	01100100000900
Closed	01100100001100
Closed	01100100001200
Closed	01095500002900
Closed	01095500001300
Closed	01095500000500
Closed	01095500009900
Closed	01095500009600
Closed	01095500006500
Closed	01095500006900
Closed	01095500007300
Closed	01095500010300
Closed	01109600004100
Closed	01109600004200
Closed	01109600004300
Closed	01109600003000
Closed	01109600002400
Closed	01097500000600
Closed	01097500000700
Closed	01097500001400
Closed	01092700000600

Accessory Dwelling Units

Index # - File Name: 1.0022 - Single Family Dwellings Data\_Snohomish County.pdf

Closed	01097400000500
Closed	00509400002609
Closed	01097400000200
Closed	01097400000800
Closed	01097400000900
Closed	01097400001000
Closed	01097400001300
Closed	01097400001500
Closed	01097400001700
Closed	01097400002000
Closed	01097400002300
Closed	01097400002400
Closed	01097400002500
Closed	01097400002600
Closed	01097400002700
Closed	01097400002800
Closed	01097400002900
Closed	01094400001300
Closed	01094400001400
Closed	01094400001500
Closed	01094400001600
Closed	28063200303200
Closed	29052300404500
Closed	01112200002500
Closed	01112200002600
Closed	01112200002700
Closed	01112200002800
Closed	01112200002900
Closed	29061600404300
Closed	28051000300500
Closed	01116100002900
Closed	01116100003000
Closed	01117300000800
Closed	01117300000100
Closed	01112300000800
Closed	01112300000900
Closed	01112300003000
Closed	01112400000100
Closed	00479901200700
Closed	01117500000100
Closed	01117500000200
Closed	01117500000300
Closed	01117500000400
Closed	01117500000500
Closed	01117500000600
Closed	01117500002300
Closed	01117500000700

Accessory Dwelling Units

Index # - File Name: 1.0022 - Single Family Dwellings Data\_Snohomish County.pdf

Closed	0111750000800
Closed	0111750000900
Closed	0111750001000
Closed	0111750001100
Closed	0111750001200
Closed	0111750001300
Closed	0111750001400
Closed	0111750001500
Closed	0111750001600
Closed	0111750001700
Closed	0111750001800
Closed	0111750001900
Closed	0111750002000
Closed	0111750002100
Closed	0111750002200
Closed	0054800000209
Closed	00493900006302
Closed	00493900006303
Closed	00493900006304
Closed	01117500004900
Closed	01117500005000
Closed	01117500005100
Closed	01117500005900
Closed	01117500006000
Closed	01117500006100
Closed	30051200402100
Closed	00394403703201
Closed	00373003002506
Closed	00493900006301
Closed	31062800401700
Closed	00597500001106
Closed	27052800209300
Closed	28060600304500
Closed	01118100000100
Closed	01118100000200
Closed	01118100000900
Closed	01118100002100
Closed	00556900002300
Closed	29061600404200
Closed	28052200401600
Closed	28052200401700
Closed	28052200401800
Closed	28052200401900
Closed	28052200402000
Closed	28060200400500
Closed	01114400000400
Closed	01114400000500

Accessory Dwelling Units

Index # - File Name: 1.0022 - Single Family Dwellings Data\_Snohomish County.pdf

Closed	0111440000600
Closed	0111440000700
Closed	0111440000800
Closed	0111440000900
Closed	0111440001000
Closed	0111220000300
Closed	29052300404700
Closed	29052300404900
Closed	29052300405000
Closed	0111320000200
Closed	0111320000300
Closed	0111320000400
Closed	0111320000500
Closed	0111320000600
Closed	28052100203100
Closed	28052100203200
Closed	28052100203300
Closed	28052100203400
Closed	28052100203500
Closed	28052100203600
Closed	28052100203800
Closed	28052100203900
Closed	01114100000100
Closed	01114400001200
Closed	01114400001300
Closed	01114400001600
Closed	01114400001700
Closed	01112300000100
Closed	01112300000200
Closed	01112300000300
Closed	01112300000400
Closed	01112300000500
Closed	01112300000600
Closed	01112300001300
Closed	01112300001400
Closed	01112300001500
Closed	01112300002100
Closed	01112300002200
Closed	01112300002300
Closed	01112300002400
Closed	01112300002500
Closed	01112300002600
Closed	01112300002700
Closed	01112300002800
Closed	32042500201900
Closed	32042500202000
Closed	32042500202100

Accessory Dwelling Units

Index # - File Name: 1.0022 - Single Family Dwellings Data\_Snohomish County.pdf

Closed	32060300301900
Closed	28060900404700
Closed	30061000300800
Closed	01116100000100
Closed	01116100000200
Closed	01116100000300
Closed	01116100000400
Closed	01116100000500
Closed	01116100000600
Closed	01116100000700
Closed	01116100000800
Closed	01116100000900
Closed	01116100001000
Closed	01116100001100
Closed	01116100001200
Closed	01116100001300
Closed	01116100001400
Closed	01116100001500
Closed	01116100001600
Closed	01116100001700
Closed	01116100001800
Closed	01116100001900
Closed	01116100002000
Closed	01116100002100
Closed	01116100002200
Closed	01116100002300
Closed	01116100002400
Closed	27051800401300
Closed	01119900000100
Closed	01119900000300
Closed	01119900001600
Closed	01119900001700
Closed	01119900001900
Closed	00381900003700
Closed	00635000000200
Closed	01120500000800
Closed	01120500000900
Closed	01120500000100
Closed	01120500000200
Closed	27062900302200
Closed	01097400002100
Closed	01097400002200
Closed	00509400002608
Closed	01097400000600
Closed	01097400000700
Closed	01092700000200
Closed	01092700000500



Accessory Dwelling Units

Index # - File Name: 1.0022 - Single Family Dwellings Data\_Snohomish County.pdf

Closed	01090600001000
Closed	01090600000700
Closed	01090600000800
Closed	01090600001200
Closed	01094400000300
Closed	01094400000400
Closed	01094400000500
Closed	01094400000600
Closed	01094400000900
Closed	01094400001000
Closed	01094400001100
Closed	01094400001200
Closed	01097400001900
Closed	01097500001200
Closed	01097500001300
Closed	01097500000900
Closed	01097500000200
Closed	01097500000300
Closed	00614800003200
Closed	00614800003300
Closed	00419500001404
Closed	00419500001411
Closed	28052900101700
Closed	28052900102300
Closed	01095500007700
Closed	27052800209100
Closed	01095500009300
Closed	01095500004900
Closed	01100100000600
Closed	01100100000200
Closed	01095500007800
Closed	01095500007900
Closed	01095500008000
Closed	01095500005000
Closed	01095500005100
Closed	01095500005200
Closed	01095500009400
Closed	01095500009500
Closed	01098700001700
Closed	01098700001800
Closed	01098700001900
Closed	01098700002000
Closed	01098700002100
Closed	01098700000900
Closed	01098700001000
Closed	01098700001100
Closed	01098700001200

Accessory Dwelling Units

Index # - File Name: 1.0022 - Single Family Dwellings Data\_Snohomish County.pdf

Closed	01098700001300
Closed	01098700001400
Closed	01098700001500
Closed	01098700000700
Closed	01098700000500
Closed	01098700000300
Closed	27052100306200
Closed	00373003001003
Closed	00373003001004
Closed	00373003001005
Closed	00373003001006
Closed	00373003001007
Closed	01101800001300
Closed	01101800001600
Closed	01101800000200
Closed	30050200303800
Closed	27050700202800
Closed	27050700203000
Closed	00466600001800
Closed	28042400410100
Closed	01101800004100
Closed	01101800004200
Closed	01101800002500
Closed	01101800002800
Closed	01101800005200
Closed	01101800005700
Closed	01101800004600
Closed	01101800004800
Closed	01101800005000
Closed	01103500000100
Closed	01103500001000
Closed	01103500001100
Closed	01103500000600
Closed	01103500000300
Closed	32042700203300
Closed	00466200010800
Closed	00381900003900
Closed	01103500001500
Closed	01103500001600
Closed	32061600400700
Closed	01108100000700
Closed	32042700203800
Closed	00431301201703
Closed	01114700002200
Closed	01114700001800
Closed	01114700001900
Closed	01114700002000

Accessory Dwelling Units

Index # - File Name: 1.0022 - Single Family Dwellings Data\_Snohomish County.pdf

Closed	0111470000400
Closed	0111470000100
Closed	0111470000200
Closed	32040300101500
Closed	0111220000700
Closed	0111220000800
Closed	0111220000300
Closed	00431300601204
Closed	0111400000200
Closed	0111400000300
Closed	0111400000400
Closed	0111400000500
Closed	0111400000600
Closed	0111400000700
Closed	0111400000900
Closed	0111400001200
Closed	0111400001300
Closed	0111400001400
Closed	0111400001500
Closed	0111400001600
Closed	0111400001700
Closed	27072000400200
Closed	0111470000700
Closed	0110790000100
Closed	01108100003000
Closed	01107900000400
Closed	01108100001900
Closed	01108100002000
Closed	01108100002100
Closed	01108100001700
Closed	01108100001300
Closed	01108100001400
Closed	01108100001500
Closed	01111300000500
Closed	01111300002400
Closed	01111300003200
Closed	01111300003300
Closed	00373001501603
Closed	01117200100500
Closed	01117200100700
Closed	01117200101100
Closed	01110300001400
Closed	01110300001000
Closed	01110300000500
Closed	01110300000600
Closed	01110300000700
Closed	01117200100900

Accessory Dwelling Units

Index # - File Name: 1.0022 - Single Family Dwellings Data\_Snohomish County.pdf

Closed	01104900001600
Closed	01104900001700
Closed	01104900001800
Closed	01104900002700
Closed	01104900002800
Closed	01104900002900
Closed	01104900003000
Closed	01104900003100
Closed	01104900000100
Closed	01104900000200
Closed	01104900000300
Closed	01104900000400
Closed	01104900000500
Closed	00508900001802
Closed	00508900001803
Closed	00508900001804
Closed	00508900001805
Closed	00508900001806
Closed	27052800209200
Closed	00508900001814
Closed	00508900001813
Closed	00508900001812
Closed	00508900001809
Closed	00508900001808
Closed	00508900001807
Closed	01104900001100
Closed	01104900001200
Closed	01104900001300
Closed	01104900001400
Closed	01081100000900
Closed	01081100001000
Closed	01081100001100
Closed	01081100001200
Closed	01081100000600
Closed	01081100000700
Closed	30040100100600
Closed	01113600000200
Closed	01113600000300
Closed	01113600000400
Closed	01113600000500
Closed	01113600000600
Closed	01113600000700
Closed	01113600000800
Closed	01113600000900
Closed	01113600001000
Closed	01113600001100
Closed	01113600001200

Accessory Dwelling Units

Index # - File Name: 1.0022 - Single Family Dwellings Data\_Snohomish County.pdf

Closed	01113600001300
Closed	01113600001400
Closed	01113600001500
Closed	01113600001600
Closed	01113600001700
Closed	01113600001800
Closed	01113600001900
Closed	01113600002000
Closed	01113600000100
Closed	27063200301700
Closed	01077100002700
Closed	01077100003000
Closed	01077100000300
Closed	01077100000400
Closed	01077100001000
Closed	01077100002300
Closed	01077100002400
Closed	01080300000900
Closed	01080300001000
Closed	01080300001100
Closed	01080300001700
Closed	01080300001800
Closed	01080300001900
Closed	01080300002000
Closed	01080300002100
Closed	01079400000300
Closed	01079400001300
Closed	01079400000700
Closed	01079400000800
Closed	01079400000900
Closed	01079400001000
Closed	01091800000500
Closed	01091800000600
Closed	01091800000700
Closed	01091800000800
Closed	01091800000900
Closed	01091800001000
Closed	01091800001100
Closed	01091800001200
Closed	01091800001300
Closed	01091800001400
Closed	01091800001500
Closed	01091800001600
Closed	01091800001700
Closed	01091800001800
Closed	01091800001900
Closed	01091800002000

Accessory Dwelling Units

Index # - File Name: 1.0022 - Single Family Dwellings Data\_Snohomish County.pdf

Closed	01091800002100
Closed	01091800008100
Closed	01091800008200
Closed	01091800008300
Closed	01091800008400
Closed	01091800006800
Closed	01091800006900
Closed	01091800007000
Closed	01091800007100
Closed	01091800007200
Closed	01091800007300
Closed	01075200000900
Closed	01078600002700
Closed	01078600002100
Closed	01078600002200
Closed	01078600001900
Closed	01078600003300
Closed	01078600002900
Closed	01078600003000
Closed	01078600001600
Closed	00373701300115
Closed	01086000004200
Closed	01086000004300
Closed	28051700402900
Closed	01095800002700
Closed	01095800002800
Closed	01075600003900
Closed	01075600004000
Closed	01075600004100
Closed	00533800002602
Closed	01100200000400
Closed	01086600000600
Closed	01086600000700
Closed	27063300102800
Closed	01100200000700
Closed	01100200000800
Closed	01100200000900
Closed	01100200001000
Closed	01100200001100
Closed	01087700000300
Closed	32041300301600
Closed	32041300301700
Closed	32041300301800
Closed	01087700000700
Closed	01087700000800
Closed	01086600001800
Closed	01086600001900

Accessory Dwelling Units

Index # - File Name: 1.0022 - Single Family Dwellings Data\_Snohomish County.pdf

Closed	01086600002000
Closed	01086600002100
Closed	01086600002200
Closed	01086700001900
Closed	00509200200804
Closed	27062600201500
Closed	01086700000100
Closed	01086700000300
Closed	00373002202107
Closed	01081400001100
Closed	01081400001200
Closed	01081400000400
Closed	01081400000500
Closed	01081400000600
Closed	01081400000700
Closed	01081400000800
Closed	01081400001600
Closed	01081400001700
Closed	01081400001800
Closed	01081400001900
Closed	01081400002300
Closed	01109200001600
Closed	01086900001400
Closed	01086900001500
Closed	01086900001600
Closed	01086900001700
Closed	01081100001400
Closed	00375000006305
Closed	00375000006306
Closed	01086900000300
Closed	01086900000400
Closed	01086900000600
Closed	01086900000700
Closed	01086900000900
Closed	01086900001100
Closed	01086900001200
Closed	01093300010200
Closed	01093300010300
Closed	01093300010400
Closed	01093300010500
Closed	01093300010600
Closed	01093300010000
Closed	01093300009100
Closed	01093300009200
Closed	01093300009300
Closed	01093300009400
Closed	01093300009500

Accessory Dwelling Units

Index # - File Name: 1.0022 - Single Family Dwellings Data\_Snohomish County.pdf

Closed	01093300005800
Closed	01093300005900
Closed	01093300006000
Closed	01093300006200
Closed	01093300006300
Closed	01093300006400
Closed	01093300009700
Closed	01090600000200
Closed	01090600000300
Closed	27051700411000
Closed	27051700411100
Closed	27051700410000
Closed	27051700410100
Closed	27051700409700
Closed	29063000105700
Closed	27063300402800
Closed	01093300000300
Closed	01093300000400
Closed	01093300000500
Closed	01093300000600
Closed	01093300003300
Closed	01093300000800
Closed	01093300004000
Closed	01093300004100
Closed	01093300001000
Closed	01093300001100
Closed	01093300001200
Closed	01088100001600
Closed	01088100001700
Closed	01090500000100
Closed	01090500000200
Closed	01090500000300
Closed	01090500000400
Closed	01090500000500
Closed	01090500000600
Closed	01090500000700
Closed	01090500000800
Closed	01090500000900
Closed	01090500001000
Closed	01090500001100
Closed	01090500001200
Closed	01090000000700
Closed	28071800302800
Closed	01079700000800
Closed	01048000004200
Closed	01048000005200
Closed	01048000005300



Accessory Dwelling Units

Index # - File Name: 1.0022 - Single Family Dwellings Data\_Snohomish County.pdf

Closed	0104800006400
Closed	0104800004700
Closed	0104800004800
Closed	0104800004900
Closed	0104800005000
Closed	0104800003500
Closed	0104800003700
Closed	0104800003800
Closed	0104800007400
Closed	0104800007500
Closed	0104800007900
Closed	0104800009800
Closed	0104800009100
Closed	0104800008900
Closed	0104800010200
Closed	0105300001500
Closed	0105300002300
Closed	0105300002400
Closed	0105300001100
Closed	0105340002100
Closed	31040900101700
Closed	31042200203300
Closed	01089100003501
Closed	01053800002300
Closed	01053800000900
Closed	01053800001000
Closed	01053800001200
Closed	01053800001300
Closed	01053800001400
Closed	01053800001500
Closed	01053800001600
Closed	01053800001700
Closed	01053800001800
Closed	01053800001900
Closed	01089100002301
Closed	01089100002601
Closed	01053800002600
Closed	01053800002700
Closed	01057200000500
Closed	01057200000200
Closed	01057200005400
Closed	01057200006800
Closed	01057200006900
Closed	01057200006400
Closed	01054700003200
Closed	01054700003300
Closed	01054700004800

Accessory Dwelling Units

Index # - File Name: 1.0022 - Single Family Dwellings Data\_Snohomish County.pdf

Closed	01054700004900
Closed	01054700005000
Closed	01054700005100
Closed	01054700005200
Closed	01054700005300
Closed	01054700005400
Closed	01054700005500
Closed	01054700005600
Closed	01054700005700
Closed	01054700005800
Closed	01054700005900
Closed	01054700006000
Closed	01054700006100
Closed	01054700006200
Closed	01054700006300
Closed	01054700006400
Closed	01054700006500
Closed	01054700006600
Closed	01054700006700
Closed	00562800006104
Closed	01054700002500
Closed	01054700002600
Closed	01057200007800
Closed	01057200007900
Closed	01057200008000
Closed	01057200008100
Closed	01054700000400
Closed	01054700000500
Closed	01054700000600
Closed	01054700000700
Closed	01054700000800
Closed	01054700000900
Closed	01054700001000
Closed	01054700001100
Closed	01054700001200
Closed	01054700001300
Closed	01054700001400
Closed	01054700001500
Closed	01054700001600
Closed	01054700001700
Closed	01054700001800
Closed	01054700001900
Closed	01054700002000
Closed	01054700002100
Closed	01054700002200
Closed	01054700002300
Closed	01095800003100

Accessory Dwelling Units

Index # - File Name: 1.0022 - Single Family Dwellings Data\_Snohomish County.pdf

Closed	01075600003200
Closed	01075600003500
Closed	01075600003600
Closed	01095800003700
Closed	01095800002200
Closed	01095800002300
Closed	01095800002400
Closed	01095800002500
Closed	01095800001900
Closed	01075600002000
Closed	01075700001200
Closed	01095800001400
Closed	01075600001600
Closed	01075600001700
Closed	01095800000500
Closed	01095800000600
Closed	01095800000700
Closed	01075000000200
Closed	01075000000300
Closed	01075000000400
Closed	28051700411100
Closed	01068600001200
Closed	01068600001300
Closed	01075900009400
Closed	01075900009500
Closed	01075900009600
Closed	01075900009700
Closed	01075900009800
Closed	01075900009900
Closed	01075900010000
Closed	01075900008300
Closed	01075900008400
Closed	01075900008500
Closed	01075900008600
Closed	01075900008700
Closed	01075900008800
Closed	01075900008900
Closed	01075900009000
Closed	01075900009100
Closed	01075900009200
Closed	01068600000900
Closed	01068600001000
Closed	01068600000400
Closed	01068600000500
Closed	01068600000600
Closed	01068600000700
Closed	01047500002700

Accessory Dwelling Units

Index # - File Name: 1.0022 - Single Family Dwellings Data\_Snohomish County.pdf

Closed	28052700201400
Closed	28052700201500
Closed	28052700201600
Closed	28052700201700
Closed	28052700201800
Closed	28052700201900
Closed	01069200005400
Closed	01069200001300
Closed	01069200001400
Closed	01069200001500
Closed	01069200001900
Closed	01069200002000
Closed	01069200002100
Closed	01069200002200
Closed	01064100001400
Closed	01064100001100
Closed	01064100001200
Closed	28051700412500
Closed	01069200000700
Closed	01069200000800
Closed	01066200000100
Closed	01066200003200
Closed	01066200005100
Closed	01066200005200
Closed	01066200005300
Closed	01066200005400
Closed	01064100000300
Closed	00373700501411
Closed	01066200002900
Closed	01066200002500
Closed	01066200002600
Closed	01066200002200
Closed	01066200004200
Closed	01066200004300
Closed	01066200004400
Closed	01066200000900
Closed	01066200000500
Closed	01066200000600
Closed	01066200000700
Closed	01066200001200
Closed	01066200001300
Closed	01066200001400
Closed	01066200001500
Closed	01066200001600
Closed	32040700101700
Closed	01068700004700
Closed	01068700004800

Accessory Dwelling Units

Index # - File Name: 1.0022 - Single Family Dwellings Data\_Snohomish County.pdf

Closed	01068700004900
Closed	01061500002900
Closed	01061500002700
Closed	01059400001300
Closed	01056300000901
Closed	01056300001001
Closed	01054700008300
Closed	01054700008400
Closed	01054700008500
Closed	01054700008600
Closed	01058300001400
Closed	01058300001500
Closed	01058300001600
Closed	01058300001700
Closed	01058300001900
Closed	01058300002000
Closed	01058300002100
Closed	01058300002200
Closed	01056400000100
Closed	01063500007100
Closed	01063500007300
Closed	01063500007400
Closed	01063500005800
Closed	01063500005900
Closed	01063500004900
Closed	01063500001600
Closed	01063500001900
Closed	01063500002100
Closed	01063500001200
Closed	01063500001000
Closed	01063500000400
Closed	01063500000500
Closed	01063500000700
Closed	01063500000800
Closed	01063500002600
Closed	01063500002300
Closed	01063500000200
Closed	01082500001600
Closed	01082500001700
Closed	01082500001800
Closed	01082500001900
Closed	01082500002000
Closed	01063200000100
Closed	01063200000200
Closed	01063200000300
Closed	01063200001000
Closed	31040400301300

Accessory Dwelling Units

Index # - File Name: 1.0022 - Single Family Dwellings Data\_Snohomish County.pdf

Closed	32042600300900
Closed	30062800101300
Closed	27052200402400
Closed	00950800000200
Closed	00950800000300
Closed	00950800000400
Closed	01048500001100
Closed	01048500001400
Closed	01048500002500
Closed	01048500007000
Closed	01042000002500
Closed	01042000002600
Closed	01042000002700
Closed	01042000002800
Closed	01042000002900
Closed	01042000003000
Closed	01042000003100
Closed	01042000003200
Closed	01042000003300
Closed	01042000005500
Closed	01042000002000
Closed	01042000002100
Closed	01042000005700
Closed	01042000005800
Closed	01043500002400
Closed	01043500002500
Closed	01040500003600
Closed	32090800100600
Closed	00911300002400
Closed	30072000203400
Closed	00420500001800
Closed	00926500000800
Closed	32062900400500
Closed	00893700000200
Closed	27102000301000
Closed	27071800200400
Closed	32061600400600
Closed	31052500402400
Closed	00869900000900
Closed	00473300003406
Closed	32063200302400
Closed	27062100202100
Closed	27062100301100
Closed	27051500104900
Closed	27050900105000
Closed	27062400101500
Closed	00373700400803

Accessory Dwelling Units

Index # - File Name: 1.0022 - Single Family Dwellings Data\_Snohomish County.pdf

Closed	00373700402401
Closed	00389400100403
Closed	00414400101200
Closed	00433100001500
Closed	00433100001700
Closed	00430400002400
Closed	00460200015200
Closed	00623700003100
Closed	00623700007401
Closed	00576800102100
Closed	00526100522400
Closed	00512000211200
Closed	00509200102000
Closed	00509700000700
Closed	00491400400401
Closed	28073600101000
Closed	28063300203000
Closed	28083100300900
Closed	28072700202100
Closed	28062400402900
Closed	28062400403000
Closed	28072200201600
Closed	28072200301800
Closed	28071800400800
Closed	28071600102100
Closed	00493900001900
Closed	00485200001200
Closed	00493900004400
Closed	00614800003400
Closed	00570700200400
Closed	00574100012800
Closed	30050600100800
Closed	30040700400700
Closed	00441900000700
Closed	30040200102900
Closed	00745800000600
Closed	00489100006100
Closed	00489100002902
Closed	00489000008200
Closed	30062800201100
Closed	00382500111400
Closed	31042600100500
Closed	31051900103800
Closed	31051900302100
Closed	31051800100800
Closed	31050400200100
Closed	31060400201100

Accessory Dwelling Units

Index # - File Name: 1.0022 - Single Family Dwellings Data\_Snohomish County.pdf

Closed	31063300300300
Closed	00464200002200
Closed	32041400401200
Closed	32091100401200
Closed	32080200301100
Closed	00546900001400
Closed	00490800100800
Closed	00376800004100
Closed	30042300201900
Closed	00372601101401
Closed	30070800200600
Closed	31062700401300
Closed	30061600301200
Closed	27062700401900
Closed	28060200100200
Closed	30072000400200
Closed	00543200001602
Closed	00490500000900
Closed	00490200000700
Closed	00587200004100
Closed	32053600200100
Closed	29061700301700
Closed	00639500000400
Closed	30050100200200
Closed	28061400404000
Closed	00629600011100
Closed	32063300200100
Closed	00836500004200
Closed	28081900300300
Closed	27061700101100
Closed	30040800401100
Closed	31040100100900
Closed	32090700401700
Closed	30061700202000
Closed	00494511501600
Closed	00494511901200
Closed	00532900003100
Closed	32050700302400
Closed	32090500401000
Closed	32081100202000
Closed	32041600301600
Closed	32061900100400
Closed	32052700200800
Closed	00394401001200
Closed	31063100301700
Closed	31040300201900
Closed	31050500200400



Accessory Dwelling Units

Index # - File Name: 1.0022 - Single Family Dwellings Data\_Snohomish County.pdf

Closed	31040800101300
Closed	31042000400400
Closed	00489000004400
Closed	00489200001400
Closed	00548200002601
Closed	00548100301402
Closed	29053600402000
Closed	30050600401500
Closed	30042300200100
Closed	00573800005400
Closed	00592100001300
Closed	00538000011202
Closed	00570300100700
Closed	00480401600401
Closed	29070700300300
Closed	29061400302100
Closed	00622200001800
Closed	00622200000100
Closed	28071800100700
Closed	28071000300100
Closed	28061400100700
Closed	27072900402000
Closed	28073500202300
Closed	00373300300402
Closed	00374600002402
Closed	00492600000700
Closed	00511900100100
Closed	00509800001500
Closed	00542000002100
Closed	00555300200102
Closed	00559400002400
Closed	00617300100503
Closed	00617300200302
Closed	00623700003700
Closed	00631900000800
Closed	00419500001505
Closed	00403800007906
Closed	00403800014602
Closed	00403800014602
Closed	00374100600402
Closed	00373100401301
Closed	27042300207600
Closed	00373002901102
Closed	00373002100307
Closed	27051700408300
Closed	27061900100200
Closed	32042200300500

Accessory Dwelling Units

Index # - File Name: 1.0022 - Single Family Dwellings Data\_Snohomish County.pdf

Closed	27053300111600
Closed	28070300100400
Closed	00493401001201
Closed	00493401001200
Closed	31062900403700
Closed	31060400102600
Closed	00912600001100
Closed	32051300201300
Closed	29073200100900
Closed	32041000402100
Closed	00375000006600
Closed	28063300203200
Closed	32073000401800
Closed	28070700102400
Closed	32080200404000
Closed	31060600302100
Closed	32080200400400
Closed	00394507101101
Closed	01048500001900
Closed	32052900101900
Closed	01010100003700
Closed	00394400802200
Closed	00466700004400
Closed	00935300000400
Closed	32041500300200
Closed	00935400000400
Closed	00935400000500
Closed	00935400000600
Closed	32051500301200
Closed	00556600003500
Closed	00374600002401
Closed	01057800003400
Closed	01057800003500
Closed	01057800003600
Closed	01057800003700
Closed	01057800003800
Closed	01057800003900
Closed	01057800004000
Closed	01057800003100
Closed	01057800003200
Closed	01057800002900
Closed	01057800002600
Closed	01057800002200
Closed	01062400000700
Closed	01069300000700
Closed	01063500000300
Closed	01071900001400

Accessory Dwelling Units

Index # - File Name: 1.0022 - Single Family Dwellings Data\_Snohomish County.pdf

Closed	01058200000900
Closed	01058200001000
Closed	01058200001100
Closed	01063500001800
Closed	01063500002000
Closed	01063500007500
Closed	01063500007600
Closed	01063500007700
Closed	01063500007800
Closed	01063500007200
Closed	01057700000400
Closed	01058300002300
Closed	01058300002400
Closed	01058300002500
Closed	01058300002600
Closed	01058300002700
Closed	01058300002800
Closed	01058300002900
Closed	01058300001800
Closed	01058300001300
Closed	01054700007700
Closed	01054700007800
Closed	01054700007900
Closed	01054700008000
Closed	01054700008100
Closed	01054700008200
Closed	32041400100300
Closed	01055600000400
Closed	01055600000600
Closed	01055600000700
Closed	01062400002000
Closed	01061500003200
Closed	01061500004500
Closed	29053500402200
Closed	01062400001500
Closed	01066200001700
Closed	01066200001800
Closed	01066200001900
Closed	01066200002000
Closed	01066200002100
Closed	01066200001000
Closed	01066200001100
Closed	01066200002300
Closed	01066200002400
Closed	01063000000600
Closed	01064100000400
Closed	01064100000500

Accessory Dwelling Units

Index # - File Name: 1.0022 - Single Family Dwellings Data\_Snohomish County.pdf

Closed	00373700501405
Closed	28051700412000
Closed	28051700412400
Closed	01064100000800
Closed	27062700305500
Closed	01084300000300
Closed	01084300000700
Closed	00376800004904
Closed	00376800004905
Closed	00376800004906
Closed	00376800004907
Closed	00376800005001
Closed	00376800005002
Closed	01072400000700
Closed	01075600003800
Closed	01075600003300
Closed	01075600003400
Closed	01054700002400
Closed	01054700006800
Closed	01054700006900
Closed	01054700007000
Closed	01054700007100
Closed	01054700007200
Closed	01054700007500
Closed	01054700004500
Closed	01054700004600
Closed	01054700004700
Closed	01057200006500
Closed	01057200005100
Closed	01057200007700
Closed	01057200005300
Closed	01057200000300
Closed	01057200000900
Closed	01057200001000
Closed	01057200000600
Closed	01057200000700
Closed	01053800002900
Closed	01053800003000
Closed	01057200001400
Closed	01057200001200
Closed	01089100003801
Closed	01089100003901
Closed	01053800000100
Closed	01089100001901
Closed	01089100002001
Closed	01089100002101
Closed	01089100002201

Accessory Dwelling Units

Index # - File Name: 1.0022 - Single Family Dwellings Data\_Snohomish County.pdf

Closed	01058000011900
Closed	01095500000100
Closed	01053400001600
Closed	01048000010700
Closed	01048000010400
Closed	01048000010500
Closed	01048000011300
Closed	00661600000100
Closed	01048000008500
Closed	01048000009700
Closed	01048000007200
Closed	01048000007300
Closed	01048000006900
Closed	01048000006700
Closed	27040200300400
Closed	27040200300400
Closed	27040200300400
Closed	27040200300400
Closed	27040200300400
Closed	27040200300400
Closed	01048000005100
Closed	01048000005600
Closed	01048000004000
Closed	28053300107900
Closed	28053300108000
Closed	28053300108100
Closed	28053300108200
Closed	28053300108300
Closed	01088000002100
Closed	01088000002200
Closed	01090000000600
Closed	01090000000100
Closed	01087900000800
Closed	01087900000900
Closed	01087900001000
Closed	01087900001100
Closed	01087900001200
Closed	01093300001300
Closed	01093300001400
Closed	01093300001500
Closed	01093300001600
Closed	01093300001700
Closed	01093300001800
Closed	01093300001900
Closed	01093300002000
Closed	01093300002100
Closed	01093300002200

Accessory Dwelling Units

Index # - File Name: 1.0022 - Single Family Dwellings Data\_Snohomish County.pdf

Closed	01093300002300
Closed	01093300002400
Closed	01093300002500
Closed	01093300002600
Closed	01093300002700
Closed	01093300002800
Closed	01093300002900
Closed	01093300003000
Closed	01093300003100
Closed	01093300003200
Closed	01093300000900
Closed	01093300003400
Closed	01093300003500
Closed	01093300003600
Closed	01093300003700
Closed	01093300003800
Closed	01093300003900
Closed	01093300000700
Closed	00570400200703
Closed	01093300005200
Closed	01093300005300
Closed	01093300005400
Closed	01093300005500
Closed	01093300005600
Closed	01093300005700
Closed	27051700409800
Closed	27051700409900
Closed	27051700410200
Closed	27051700410300
Closed	27051700411200
Closed	27051700411300
Closed	01090600000400
Closed	01090600000500
Closed	01093300009800
Closed	01093300009900
Closed	01093300006100
Closed	01093300009600
Closed	01093300010100
Closed	27051700410500
Closed	27051700410600
Closed	27051700410800
Closed	27051700410900
Closed	01086900001300
Closed	01086900000100
Closed	00611300003701
Closed	01109200001400
Closed	01109200001500

Accessory Dwelling Units

Index # - File Name: 1.0022 - Single Family Dwellings Data\_Snohomish County.pdf

Closed	0112350000200
Closed	00532100005001
Closed	00532100005002
Closed	01081400003200
Closed	01081400002700
Closed	01081400002800
Closed	01086700000400
Closed	01086700000500
Closed	01086700000200
Closed	01086700001800
Closed	01085200000100
Closed	01085200000200
Closed	01085200000300
Closed	01085200000400
Closed	01085200000500
Closed	01085200000600
Closed	01085200000700
Closed	01085200000800
Closed	01085200001000
Closed	01085200001100
Closed	01085200001200
Closed	01085200001300
Closed	01085200001400
Closed	01085200001500
Closed	01085200001600
Closed	01085200001700
Closed	01085200001800
Closed	01085200001900
Closed	01085200002000
Closed	01085200002100
Closed	01085200002200
Closed	01085200002300
Closed	01085200002400
Closed	01085200002500
Closed	01086100000500
Closed	01086100000100
Closed	01086600002300
Closed	01086600002500
Closed	01086600002600
Closed	01087700000900
Closed	01086600002800
Closed	01086600002900
Closed	01087700000200
Closed	01086600000800
Closed	01086600000900
Closed	01086600001000
Closed	01086600001100

Accessory Dwelling Units

Index # - File Name: 1.0022 - Single Family Dwellings Data\_Snohomish County.pdf

Closed	01074900000400
Closed	01074900000500
Closed	01074900000700
Closed	01074900000900
Closed	01075200000500
Closed	01075200000600
Closed	01075200000800
Closed	01075200000300
Closed	01091800008500
Closed	01091800008600
Closed	01091800008700
Closed	01091800008800
Closed	01091800008900
Closed	01079400000400
Closed	01079400000500
Closed	01079400000600
Closed	01091800000100
Closed	01091800000200
Closed	01091800000300
Closed	01091800000400
Closed	01077100000100
Closed	01077100000200
Closed	01077100002500
Closed	01077100002600
Closed	01077100001700
Closed	01077100001800
Closed	01077100001900
Closed	01077100002000
Closed	01077100002100
Closed	01077100002200
Closed	01077100001100
Closed	01077100001200
Closed	01077100001300
Closed	01077100001400
Closed	01077100000500
Closed	01077100000600
Closed	01077100000700
Closed	01081200000100
Closed	01081200001700
Closed	01081200001900
Closed	01081200000400
Closed	01081200000800
Closed	01081200000900
Closed	01081200001000
Closed	01081200001100
Closed	01081200001300
Closed	00375000006304



Accessory Dwelling Units

Index # - File Name: 1.0022 - Single Family Dwellings Data\_Snohomish County.pdf

Closed	01104900001500
Closed	00508900001811
Closed	00508900001810
Closed	32042500201200
Closed	00508900001902
Closed	01104900000600
Closed	01104900000700
Closed	01104900000800
Closed	01104900000900
Closed	01104900001000
Closed	01104900003200
Closed	01104900003300
Closed	01104900003400
Closed	01104900001900
Closed	01104900002000
Closed	01104900002100
Closed	01104900002200
Closed	01104900002300
Closed	01104900002400
Closed	01104900002500
Closed	01104900002600
Closed	01117200101000
Closed	01117200202300
Closed	01117200202400
Closed	01117200202900
Closed	01117200203000
Closed	01117200203100
Closed	01117200203500
Closed	01117200204200
Closed	01117200204300
Closed	01117200204400
Closed	01117200204900
Closed	01117200205000
Closed	01117200202600
Closed	01117200204600
Closed	01124200000100
Closed	01124200000200
Closed	01117200206700
Closed	01124200000600
Closed	01124200000700
Closed	01124200001400
Closed	01124200001500
Closed	01124200001600
Closed	01124200001800
Closed	01105300006000
Closed	01105300004000
Closed	01105300006200

Accessory Dwelling Units

Index # - File Name: 1.0022 - Single Family Dwellings Data\_Snohomish County.pdf

Closed	01105300006300
Closed	01105300006400
Closed	01105300006500
Closed	01117200101200
Closed	01117200100800
Closed	01117200100600
Closed	01117200100100
Closed	01117200100200
Closed	01117200100300
Closed	01117200100400
Closed	01117200201500
Closed	01117200201600
Closed	01117200201700
Closed	01117200201800
Closed	01117200201900
Closed	01117200202000
Closed	01117200202100
Closed	01109000000400
Closed	01109000000500
Closed	01111300000800
Closed	01111300000900
Closed	01111300001000
Closed	01111300001100
Closed	01111300001200
Closed	01111300001300
Closed	01111300001400
Closed	01111300001500
Closed	01109000000700
Closed	01109000000800
Closed	30040100103800
Closed	01124200005000
Closed	01124200000900
Closed	01108100000100
Closed	01108100000200
Closed	01111300000200
Closed	01108100000600
Closed	01108100001600
Closed	01108100001800
Closed	01108100000900
Closed	01108100001100
Closed	01108100002300
Closed	01107900000500
Closed	01107900000600
Closed	01107900000700
Closed	01107900000200
Closed	01107900000300
Closed	01108100003200

Accessory Dwelling Units

Index # - File Name: 1.0022 - Single Family Dwellings Data\_Snohomish County.pdf

Closed	01117600001300
Closed	01114700000800
Closed	01114700000900
Closed	01114700001000
Closed	01114700001200
Closed	01114700001400
Closed	01114700001600
Closed	01114700001700
Closed	00403800014501
Closed	01110500001800
Closed	31060400302900
Closed	01110500001600
Closed	27070100101400
Closed	01114700002400
Closed	01114700002500
Closed	00373700300302
Closed	01110500002000
Closed	01110500002200
Closed	01103500001700
Closed	01103500000700
Closed	01103500000800
Closed	01103500000900
Closed	01103500000200
Closed	01103500000500
Closed	01101800001200
Closed	01101800002700
Closed	01101800003300
Closed	01101800003600
Closed	01101800003700
Closed	27052100307200
Closed	27052100307300
Closed	27052100307400
Closed	01101800000100
Closed	27050700203100
Closed	01106200000200
Closed	27050700202900
Closed	00532100004902
Closed	00532100004903
Closed	01101800000300
Closed	01095500001700
Closed	27050700203300
Closed	27050700203400
Closed	01095500006200
Closed	01095500006300
Closed	01095500006400
Closed	01095500000200
Closed	01095500000300

Accessory Dwelling Units

Index # - File Name: 1.0022 - Single Family Dwellings Data\_Snohomish County.pdf

Closed	01095500000400
Closed	01095500001800
Closed	01095500001900
Closed	01095500002000
Closed	01095500008200
Closed	01095500008300
Closed	01095500008400
Closed	01097800000100
Closed	01097800000200
Closed	01097800000300
Closed	01095500006100
Closed	01095500008100
Closed	30051100402400
Closed	01097500000400
Closed	01097500000500
Closed	01097500000800
Closed	01095600000100
Closed	01095600000200
Closed	01095600000300
Closed	01095600000400
Closed	01095600000500
Closed	01095600000600
Closed	01095600000700
Closed	01095600000800
Closed	01095600000900
Closed	01095600001000
Closed	01095600001100
Closed	01095600001200
Closed	01095600001300
Closed	01097500000100
Closed	01097500001100
Closed	01090600001300
Closed	01096200000100
Closed	01096200000200
Closed	01090600001100
Closed	01095700000400
Closed	01097400001800
Closed	01097400001600
Closed	01097400001400
Closed	01096200001300
Closed	01095700000600
Closed	01095700000800
Closed	00509400002601
Closed	01095700001400
Closed	01095700001600
Closed	00509400002602
Closed	00509400002603

Accessory Dwelling Units

Index # - File Name: 1.0022 - Single Family Dwellings Data\_Snohomish County.pdf

Closed	00509400002604
Closed	00509400002605
Closed	00509400002606
Closed	00509400002607
Closed	01120500000300
Closed	01120500000400
Closed	01120500000500
Closed	01120500000600
Closed	01120500000700
Closed	01120500002100
Closed	01120500002200
Closed	01120500002300
Closed	01120500001000
Closed	01120500001100
Closed	01120500001200
Closed	01120500001300
Closed	01120500001400
Closed	01120500001500
Closed	01120500001600
Closed	01120500001700
Closed	01120500001800
Closed	01120500001900
Closed	01120500002600
Closed	01120500002700
Closed	01120500002800
Closed	01120500002900
Closed	01120500003000
Closed	29062800301700
Closed	01120500003800
Closed	01120500004100
Closed	01120500004800
Closed	01120500004900
Closed	01120500005000
Closed	01120500005100
Closed	01120500005200
Closed	01120500005300
Closed	01120500005400
Closed	01120500005500
Closed	01120500005600
Closed	01120500005700
Closed	01120500005800
Closed	01120500005900
Closed	01120500006000
Closed	01120500006100
Closed	01120500006200
Closed	01120500006300
Closed	01120500006400

Accessory Dwelling Units

Index # - File Name: 1.0022 - Single Family Dwellings Data\_Snohomish County.pdf

Closed	01120500006500
Closed	01120500006600
Closed	01120500006700
Closed	01120500006800
Closed	01120500006900
Closed	01120500007000
Closed	00401000007400
Closed	01122700000400
Closed	01122700000500
Closed	01122700000600
Closed	01122700001400
Closed	01122700001600
Closed	32052400100700
Closed	01121800000100
Closed	01121800000200
Closed	01121800000300
Closed	01121800000400
Closed	01121800000500
Closed	01121800000600
Closed	01121800000700
Closed	01121800000800
Closed	01121800000900
Closed	01121800001000
Closed	01121800001200
Closed	01121800001300
Closed	00394403702901
Closed	01123200000600
Closed	01123200000700
Closed	01123200000800
Closed	01123200000900
Closed	01123200001000
Closed	01123200001100
Closed	01123200001200
Closed	01123200001300
Closed	01123200001400
Closed	01123200001500
Closed	28060200305200
Closed	01119900000500
Closed	01119900000700
Closed	01119900000900
Closed	01119900001100
Closed	01119900001200
Closed	01119900001300
Closed	01119900001400
Closed	01119900001500
Closed	01122100000300
Closed	00608100600205

Accessory Dwelling Units

Index # - File Name: 1.0022 - Single Family Dwellings Data\_Snohomish County.pdf

Closed	00614700500902
Closed	27051800401300
Closed	01118100002000
Closed	00372800800912
Closed	27051800401300
Closed	01122500000100
Closed	01122500000200
Closed	01122500000300
Closed	01122500000400
Closed	01122500000500
Closed	01122500000600
Closed	01122500000700
Closed	01122500000800
Closed	01122500000900
Closed	01122500001000
Closed	01122500001100
Closed	01122500001200
Closed	01122500001300
Closed	01122500001400
Closed	01122500001500
Closed	01122500001600
Closed	01122500001700
Closed	01122500001800
Closed	01122500001900
Closed	01122500002000
Closed	01122500002100
Closed	01122500002200
Closed	01122500002300
Closed	01122500002400
Closed	01122500002500
Closed	01122500002600
Closed	01122500002700
Closed	01122500002800
Closed	01123200002000
Closed	01123200002100
Closed	01123200002200
Closed	01123200002300
Closed	01123200002400
Closed	01123200002500
Closed	01123200002600
Closed	01123200002700
Closed	01123200002800
Closed	01120900000100
Closed	01120900000200
Closed	01120900000300
Closed	01120900000400
Closed	01120900000500

Accessory Dwelling Units

Index # - File Name: 1.0022 - Single Family Dwellings Data\_Snohomish County.pdf

Closed	01120900000600
Closed	01120900000700
Closed	01120900000800
Closed	01120900000900
Closed	01120900001000
Closed	01120900001100
Closed	01120900001200
Closed	01126500000400
Closed	01120500004500
Closed	01120500004600
Closed	31062000200500
Closed	01120600000300
Closed	01120600000400
Closed	01120600000500
Closed	01120600000600
Closed	01120600000700
Closed	01120600000800
Closed	01120600000900
Closed	01120600001000
Closed	01120600001100
Closed	01120600001200
Closed	01120600001300
Closed	01120600001400
Closed	01120600001500
Closed	01120600002400
Closed	01120600002500
Closed	01120600002600
Closed	01120600002700
Closed	01120600002800
Closed	01120600002900
Closed	01120600003000
Closed	01120600003100
Closed	01120600003200
Closed	01120600003300
Closed	01120600003400
Closed	01120600003500
Closed	01120600003600
Closed	01120600003700
Closed	01120600003800
Closed	01125300000300
Closed	01125300000400
Closed	00617300200102
Closed	01120600000100
Closed	01125300001000
Closed	01125300001200
Closed	01125300001400
Closed	01125300001500



Accessory Dwelling Units

Index # - File Name: 1.0022 - Single Family Dwellings Data\_Snohomish County.pdf

Closed	01125300001800
Closed	01125300001900
Closed	01125300002000
Closed	27051700203300
Closed	27051700203400
Closed	28050300405000
Closed	00373003100207
Closed	00373003100208
Closed	00373003100209
Closed	00373003100210
Closed	32042600403000
Closed	00444700600700
Closed	30062200102200
Closed	27051700203000
Closed	27051700203100
Closed	01123600001400
Closed	01123600001500
Closed	01123600001600
Closed	01123600001700
Closed	01123600001800
Closed	01123600001900
Closed	01123600002300
Closed	01123600002400
Closed	01123600002500
Closed	01123600002600
Closed	01123600002700
Closed	01123600002800
Closed	01123600003200
Closed	01123600003000
Closed	01116100002500
Closed	01116100002600
Closed	01116100002700
Closed	01116100002800
Closed	01112300002900
Closed	01112300001600
Closed	01112300001700
Closed	01112300001800
Closed	01112300001900
Closed	01112300002000
Closed	01112300000700
Closed	01114400001400
Closed	01114400001500
Closed	01114400000200
Closed	01114400000300
Closed	28060200300700
Closed	00466700001300
Closed	01120000001000

Accessory Dwelling Units

Index # - File Name: 1.0022 - Single Family Dwellings Data\_Snohomish County.pdf

Closed	0112000001100
Closed	0111810000300
Closed	0111810000700
Closed	0111810000800
Closed	27052800202200
Closed	31041000103100
Closed	01117500005300
Closed	01117500005400
Closed	01117500005500
Closed	01117500005600
Closed	01117500005700
Closed	01117500005800
Closed	01117500004400
Closed	01117500002400
Closed	01117500002500
Closed	01117500002600
Closed	01117500002700
Closed	01117500002800
Closed	01117500002900
Closed	01117500003000
Closed	01117500003100
Closed	01117500003200
Closed	01117500003300
Closed	01117500003400
Closed	01117500003500
Closed	01117500003600
Closed	01112400000200
Closed	01112400000300
Closed	01112400000400
Closed	01112400000500
Closed	01112400000600
Closed	01112400000700
Closed	01112400000800
Closed	01112400000900
Closed	01112400001000
Closed	01112400001100
Closed	01112400001200
Closed	01112400001300
Closed	01112400001400
Closed	01112400001500
Closed	01112400001600
Closed	01112400001700
Closed	01112400001800
Closed	01112400001900
Closed	01112400002000
Closed	01112400002100
Closed	01112400002200

Accessory Dwelling Units

Index # - File Name: 1.0022 - Single Family Dwellings Data\_Snohomish County.pdf

Closed	01112300001000
Closed	01112300001100
Closed	01112300001200
Closed	01112400002800
Closed	01112400002900
Closed	30063400303800
Closed	01117300000200
Closed	01117300000400
Closed	01117300000500
Closed	28061900301600
Closed	01123900000100
Closed	01123900000200
Closed	01123900000300
Closed	01123900000500
Closed	01123900000600
Closed	01123900001300
Closed	01123900001400
Closed	01123900001500
Closed	01123900001600
Closed	01123900001700
Closed	01123900001800
Closed	01123900001900
Closed	01123900002000
Closed	01123900002400
Closed	01123900002500
Closed	01123900002600
Closed	01123900003200
Closed	01123900003300
Closed	01124000001900
Closed	01124000002000
Closed	01124000002100
Closed	01124000002200
Closed	01124000002300
Closed	01124000002400
Closed	01124000002500
Closed	01124000002600
Closed	01124000002700
Closed	01124000002800
Closed	01124000002900
Closed	01124000003000
Closed	01124000003100
Closed	01124000003200
Closed	01124000003300
Closed	01124000003400
Closed	01124000003500
Closed	01124000004200
Closed	01124000004300

Accessory Dwelling Units

Index # - File Name: 1.0022 - Single Family Dwellings Data\_Snohomish County.pdf

Closed	0112400004400
Closed	0112400004500
Closed	0112400004600
Closed	0112400005000
Closed	0112400005100
Closed	0112400005200
Closed	0112400005300
Closed	0112400005400
Closed	0112400005500
Closed	0112400005600
Closed	0112390004000
Closed	0112390004100
Closed	0112390004200
Closed	0112390004300
Closed	0112390004400
Closed	0112390004500
Closed	0112390004600
Closed	00574100012702
Closed	0112390002800
Closed	27050800201800
Closed	27050800201900
Closed	0112550002800
Closed	0112550002900
Closed	0112550003000
Closed	0112550003100
Closed	0112550001400
Closed	0112550001500
Closed	0112550001600
Closed	0112550001700
Closed	0112550001800
Closed	0112550001900
Closed	0112550002000
Closed	0112550002100
Closed	0112550002200
Closed	0112550002300
Closed	00512000205400
Closed	27052600200200
Closed	28063300200600
Closed	00373003100213
Closed	0112700003000
Closed	0112700003100
Closed	0112700003200
Closed	0112700003300
Closed	0112700003400
Closed	0112700003500
Closed	00594300001102
Closed	00594300001101

Accessory Dwelling Units

Index # - File Name: 1.0022 - Single Family Dwellings Data\_Snohomish County.pdf

Closed	01113900000100
Closed	00409500001200
Closed	27062200204200
Closed	01111300002000
Closed	01125900001700
Closed	01125900002400
Closed	01125900002500
Closed	01125900002600
Closed	01125900002700
Closed	01125900002800
Closed	01125900002900
Closed	01125900003000
Closed	01125900003100
Closed	01125900003200
Closed	01125900003300
Closed	01125900003400
Closed	01125900003500
Closed	01125900003600
Closed	01125900000100
Closed	01125900000200
Closed	01125900000300
Closed	01125900000400
Closed	01125900000500
Closed	01125900000600
Closed	01125900000700
Closed	01125900000800
Closed	01125900000900
Closed	01125900001000
Closed	01125900001100
Closed	01125900001200
Closed	01125900001300
Closed	01125900001400
Closed	01125900001500
Closed	01125900001900
Closed	01125900002000
Closed	01125900002100
Closed	01125900004100
Closed	01125900004200
Closed	01125900004300
Closed	01125900004500
Closed	01125900004600
Closed	01125900004700
Closed	01125900004800
Closed	01125900004900
Closed	01125900005000
Closed	01125900005100
Closed	01125900005200

Accessory Dwelling Units

Index # - File Name: 1.0022 - Single Family Dwellings Data\_Snohomish County.pdf

Closed	01125900005300
Closed	01125800000100
Closed	01125800000200
Closed	01125800000300
Closed	01125800000400
Closed	01125800000500
Closed	01125800000600
Closed	01125800000700
Closed	01125800000800
Closed	01125800000900
Closed	01125800001000
Closed	01125800001100
Closed	01125800001200
Closed	01125800001300
Closed	01125800001400
Closed	01125800001500
Closed	01125800001600
Closed	01125800001700
Closed	01125800001800
Closed	01125800001900
Closed	01126100000900
Closed	01126100001000
Closed	01126100001100
Closed	01126200004100
Closed	01126200004200
Closed	01126200004300
Closed	01126200004400
Closed	01125300002600
Closed	32081300101900
Closed	01128600000600
Closed	01126700007700
Closed	01126700007800
Closed	01126700007900
Closed	01126200002300
Closed	01126200002400
Closed	01126200002500
Closed	01126200002600
Closed	01126200002800
Closed	01126200002900
Closed	01126200003000
Closed	01126200003100
Closed	01126200003200
Closed	01126200003300
Closed	01126200003400
Closed	01126200003500
Closed	01126200003600
Closed	01126200003700

Accessory Dwelling Units

Index # - File Name: 1.0022 - Single Family Dwellings Data\_Snohomish County.pdf

Closed	01126200003800
Closed	01126200003900
Closed	01126200004600
Closed	01126200004700
Closed	01126200004800
Closed	01126200004900
Closed	01126200005000
Closed	01126200005100
Closed	01126200005200
Closed	01126200005300
Closed	01126200005400
Closed	01126200005500
Closed	01126200006200
Closed	01125900003900
Closed	01128100000200
Closed	01128100001100
Closed	01128100001200
Closed	01128100001300
Closed	01128100001500
Closed	01128100002200
Closed	01128100002300
Closed	01128100002400
Closed	01128100002900
Closed	01128100003000
Closed	01128100003100
Closed	01128100003300
Closed	01128100003400
Closed	01128100003500
Closed	01128100003600
Closed	01126900001100
Closed	01126900001200
Closed	01126900001300
Closed	01126900001400
Closed	01126900001500
Closed	01126900001600
Closed	01126900001700
Closed	01126900001800
Closed	01126900001900
Closed	01126900002000
Closed	01126900002100
Closed	01126900002200
Closed	01126900002300
Closed	01126900002400
Closed	01126900002500
Closed	01126900002600
Closed	01126900002700
Closed	01126900002800

Accessory Dwelling Units

Index # - File Name: 1.0022 - Single Family Dwellings Data\_Snohomish County.pdf

Closed	01126900002900
Closed	01126900003000
Closed	01126900003100
Closed	01126900003200
Closed	01126900003300
Closed	01126900003400
Closed	01126900003500
Closed	01126900003600
Closed	01126900003700
Closed	01126900005700
Closed	01126900005800
Closed	01126900005900
Closed	01126900006000
Closed	01126900006100
Closed	01126900006200
Closed	01126900006300
Closed	01126900006400
Closed	01126900006500
Closed	01126900006600
Closed	01126900006700
Closed	01126900006800
Closed	01126900006900
Closed	01126900007000
Closed	01126900007100
Closed	01126900007200
Closed	01126900007300
Closed	01126900007400
Closed	01126900007500
Closed	01126900007600
Closed	01126900007700
Closed	01126900007800
Closed	01126900007900
Closed	01126900008000
Closed	01126900008100
Closed	01126900008200
Closed	01126900008300
Closed	01126900008400
Closed	01126900008500
Closed	01126900008600
Closed	01126900008700
Closed	01126900008800
Closed	01126900008900
Closed	01126900009000
Closed	01126900009100
Closed	01126900009200
Closed	01126900009300
Closed	01126900009400



Accessory Dwelling Units

Index # - File Name: 1.0022 - Single Family Dwellings Data\_Snohomish County.pdf

Closed	01126900009500
Closed	01126900009600
Closed	01126900009700
Closed	01126900009800
Closed	27052800210200
Closed	27052800210300
Closed	27052800210400
Closed	27052800210500
Closed	27052800210600
Closed	27052800210700
Closed	27052800210800
Closed	27052800210900
Closed	28052700102400
Closed	32052900101200
Closed	28081800302900
Closed	28052000105300
Closed	00373700300608
Closed	00494600201504
Closed	30052500401300
Closed	01127000003600
Closed	01127000003700
Closed	01127000003800
Closed	01127000003900
Closed	01127000004000
Closed	01127000004100
Closed	01127000004200
Closed	01127000004300
Closed	01127000004400
Closed	01127000004500
Closed	01127000004600
Closed	01125500000100
Closed	01125500000200
Closed	01125500000500
Closed	01125500000600
Closed	01125500002400
Closed	01125500002500
Closed	01125500002600
Closed	01125500002700
Closed	01127000001400
Closed	01127000001500
Closed	01127000001600
Closed	01127000001700
Closed	01127000001800
Closed	01127000001900
Closed	01127000002000
Closed	01127000002100
Closed	01127000002200

Accessory Dwelling Units

Index # - File Name: 1.0022 - Single Family Dwellings Data\_Snohomish County.pdf

Closed	01127000002300
Closed	01127000002400
Closed	01127000002500
Closed	01127000002600
Closed	01127000002700
Closed	01127000002800
Closed	01127000002900
Closed	01127000000100
Closed	01127000000200
Closed	01127000000300
Closed	01127000000400
Closed	01127000000500
Closed	01127000000600
Closed	01127000000700
Closed	01127000000800
Closed	01127000000900
Closed	01127000001000
Closed	01126700003400
Closed	01126700004700
Closed	01126700004500
Closed	01126700007200
Closed	01126700007300
Closed	01126700008200
Closed	01126700008300
Closed	01126200000100
Closed	01126200000200
Closed	01126200000300
Closed	01126200000400
Closed	01126200000500
Closed	01126200000600
Closed	01126200000700
Closed	01126200000800
Closed	01126200000900
Closed	01126200001000
Closed	01126200001400
Closed	01126200001500
Closed	01126200001600
Closed	01126200001700
Closed	01126200001800
Closed	01125500003200
Closed	01125500003300
Closed	01125500003400
Closed	01125500003500
Closed	01125500003600
Closed	01125500003700
Closed	01125500003800
Closed	01125500003900

Accessory Dwelling Units

Index # - File Name: 1.0022 - Single Family Dwellings Data\_Snohomish County.pdf

Closed	01125500004000
Closed	01125500004100
Closed	31042700306400
Closed	00440000200800
Closed	01123900002900
Closed	01123900003000
Closed	01123900003100
Closed	01124000005700
Closed	01124000005800
Closed	01124000005900
Closed	01124000006000
Closed	01124000006100
Closed	01124000006200
Closed	01124000006300
Closed	01124000006400
Closed	01123900003400
Closed	01123900003500
Closed	01123900003600
Closed	01123900003700
Closed	01123900003800
Closed	01123900003900
Closed	01123900002700
Closed	01124000000100
Closed	01124000000200
Closed	01124000000300
Closed	01124000000400
Closed	01124000000500
Closed	01124000000600
Closed	01124000000700
Closed	01124000000800
Closed	01124000000900
Closed	01124000001000
Closed	01124000001100
Closed	01124000001200
Closed	01124000001300
Closed	01124000001400
Closed	01124000001500
Closed	01124000001600
Closed	01124000001700
Closed	01124000001800
Closed	01123900002100
Closed	01123900002200
Closed	01123900002300
Closed	01123600006200
Closed	01123600006300
Closed	01123600006400
Closed	01123600006500

Accessory Dwelling Units

Index # - File Name: 1.0022 - Single Family Dwellings Data\_Snohomish County.pdf

Closed	01123600006600
Closed	01123600006700
Closed	01123600007300
Closed	01123600007400
Closed	01123600007500
Closed	01123600007600
Closed	01123600007700
Closed	01123600007800
Closed	01112400002300
Closed	01112400002400
Closed	01112400002500
Closed	01112400002600
Closed	01112400002700
Closed	01117500003700
Closed	01117500003800
Closed	01117500003900
Closed	01117500004000
Closed	01117500004100
Closed	01117500004200
Closed	01117500004300
Closed	01117500004500
Closed	01117500004600
Closed	01117500004700
Closed	01117500004800
Closed	00493900006305
Closed	00493900006306
Closed	01116300000100
Closed	01116300000200
Closed	01116300000300
Closed	01116300000400
Closed	01116300000500
Closed	01116300000600
Closed	01116300000700
Closed	01116300000800
Closed	01116300000900
Closed	01116300001000
Closed	01117500005200
Closed	32062800203000
Closed	01118100001000
Closed	01118100001100
Closed	01118100001400
Closed	01118100001500
Closed	01118100001600
Closed	01114400001100
Closed	00372801600504
Closed	00372801600505
Closed	00372801600506

Accessory Dwelling Units

Index # - File Name: 1.0022 - Single Family Dwellings Data\_Snohomish County.pdf

Closed	00372801600507
Closed	00372801600508
Closed	00372801600509
Closed	00372801600510
Closed	00372801600511
Closed	01123600000400
Closed	01123600000500
Closed	01123600000600
Closed	01123600000700
Closed	01123600000800
Closed	01123600000900
Closed	01123600001000
Closed	01123600001100
Closed	01123600001200
Closed	01123600001300
Closed	01123600005200
Closed	01123600005300
Closed	01123600005400
Closed	01123600005500
Closed	01123600005600
Closed	01123600005700
Closed	01123600005800
Closed	01123600003300
Closed	01123600003400
Closed	01123600003500
Closed	01123600003600
Closed	01123600003700
Closed	01123600003800
Closed	01123600003900
Closed	01123600004000
Closed	01123600004100
Closed	01123600004200
Closed	01123600004300
Closed	01123600000100
Closed	01123600000200
Closed	01126300000300
Closed	01126300000400
Closed	01126300000600
Closed	01125300002100
Closed	01125300002200
Closed	01125300001600
Closed	01125300001700
Closed	01125300001300
Closed	01120600000200
Closed	01125300000500
Closed	01125300000600
Closed	01120600003900

Accessory Dwelling Units

Index # - File Name: 1.0022 - Single Family Dwellings Data\_Snohomish County.pdf

Closed	01120600004000
Closed	01120600004100
Closed	01120600004200
Closed	01120600004300
Closed	01120600001600
Closed	01120600001700
Closed	01120600001800
Closed	01120600001900
Closed	01120600002000
Closed	01120600002100
Closed	01120600002200
Closed	01120600002300
Closed	01120500004700
Closed	01124600000300
Closed	01124600000400
Closed	01124600000500
Closed	01124600000900
Closed	01124600001000
Closed	01124600001100
Closed	01124600001200
Closed	01126500000500
Closed	01126500000600
Closed	01126500000700
Closed	01126500000800
Closed	01126500000900
Closed	01126500001000
Closed	01126500001100
Closed	01126500001200
Closed	01126500001400
Closed	01126500001500
Closed	01126500001600
Closed	01126500001700
Closed	01124600000100
Closed	01126500000100
Closed	01126500000200
Closed	01126500000300
Closed	01123200001600
Closed	01123200001700
Closed	01122700000100
Closed	01122700000200
Closed	01122700000300
Closed	01120500004200
Closed	01120500004300
Closed	01120500004400
Closed	01120500003900
Closed	01120500004000
Closed	01120500003100

Accessory Dwelling Units

Index # - File Name: 1.0022 - Single Family Dwellings Data\_Snohomish County.pdf

Closed	01120500003200
Closed	01120500003300
Closed	01120500003400
Closed	01120500003500
Closed	01120500003600
Closed	01120500003700
Closed	01120500002000
Closed	01120500002400
Closed	01120500002500
Closed	27051400302500
Closed	27051400307500
Closed	32041400100700
Closed	32042600102600
Closed	29052600103600
Closed	27062800404000
Closed	31041300200200
Closed	00374100400403
Closed	32052600300500
Closed	28060300302900
Closed	01129100000200
Closed	01129100000300
Closed	01129100000400
Closed	01129100000500
Closed	01129100001300
Closed	01129100001400
Closed	01129100001500
Closed	01129100001600
Closed	01129100001700
Closed	01129100001800
Closed	01129100001900
Closed	00494511501402
Closed	00373002203100
Closed	01129800000200
Closed	01129800000300
Closed	01132100001400
Closed	00373002102203
Closed	01095700001700
Closed	01095700001500
Closed	01095700000200
Closed	01095700000300
Closed	01095700001200
Closed	01095700001300
Closed	01098600002900
Closed	01098600003000
Closed	01095700000100
Closed	01097400001100
Closed	01097400001200

Accessory Dwelling Units

Index # - File Name: 1.0022 - Single Family Dwellings Data\_Snohomish County.pdf

Closed	0109860000200
Closed	0109860000400
Closed	0109620000300
Closed	0109620000400
Closed	0109620000500
Closed	0109620000600
Closed	0109060000900
Closed	0109060000100
Closed	0109620000800
Closed	0109620000900
Closed	01096200001000
Closed	01096200001100
Closed	01096200001200
Closed	01098600003200
Closed	01098600000800
Closed	01098600001400
Closed	01098600001600
Closed	01098600001900
Closed	01098600002400
Closed	01105600000400
Closed	01105600000500
Closed	01105600000600
Closed	01105600000700
Closed	01105600000800
Closed	01105600000900
Closed	01105600001000
Closed	01105600001100
Closed	01105600001200
Closed	01105600001300
Closed	01105600001400
Closed	01097500001000
Closed	01095500002500
Closed	01095500005300
Closed	01095500005700
Closed	01095500008500
Closed	01095500002100
Closed	01095500008900
Closed	01095500008600
Closed	01095500008700
Closed	01095500008800
Closed	01095500009000
Closed	01095500009100
Closed	01095500009200
Closed	01095500002200
Closed	01095500002300
Closed	01095500002400
Closed	01095500002600



Accessory Dwelling Units

Index # - File Name: 1.0022 - Single Family Dwellings Data\_Snohomish County.pdf

Closed	01095500002700
Closed	01095500002800
Closed	01095500005400
Closed	01095500005500
Closed	01095500005600
Closed	01095500005800
Closed	01095500005900
Closed	01095500006000
Closed	01093700000100
Closed	27052100306700
Closed	00372800600701
Closed	01093700000200
Closed	01093700000300
Closed	01093700000600
Closed	01103300001300
Closed	01106200000100
Closed	01101800000400
Closed	01101800001000
Closed	01101800001100
Closed	01101800001700
Closed	01101800001800
Closed	01101800001900
Closed	01101800002000
Closed	01101800002100
Closed	01101800001400
Closed	01101800001500
Closed	01101800002400
Closed	27052100307000
Closed	27052100307100
Closed	01101800002600
Closed	01101800002900
Closed	01101800003100
Closed	01101800003200
Closed	01110500002300
Closed	01110500000300
Closed	01110500000400
Closed	01110500000500
Closed	01110500000600
Closed	01110500000700
Closed	01110500000800
Closed	01110500000900
Closed	01110500001000
Closed	01126600003200
Closed	01126600003300
Closed	01126600003400
Closed	01126600003500
Closed	01126600003600

Accessory Dwelling Units

Index # - File Name: 1.0022 - Single Family Dwellings Data\_Snohomish County.pdf

Closed	0112660000600
Closed	0112660000700
Closed	01110500001700
Closed	01112200000500
Closed	01112200001900
Closed	01112200002000
Closed	01112200002100
Closed	01109500000100
Closed	01109500000400
Closed	01109500000500
Closed	01109500000600
Closed	01109500002800
Closed	01117600001400
Closed	01117600001500
Closed	01117600000500
Closed	01117600000600
Closed	01108100002800
Closed	01110600000100
Closed	01110600000200
Closed	01110600000300
Closed	01110600000400
Closed	01108100002400
Closed	01108100002600
Closed	01108100002200
Closed	01111300002500
Closed	01111300002600
Closed	01111300002700
Closed	01111300002800
Closed	01111300002900
Closed	01108100000300
Closed	01108100000400
Closed	01108100000500
Closed	01124200001200
Closed	01124200001300
Closed	011242000005100
Closed	01109000001300
Closed	01109000001400
Closed	01109000001500
Closed	01109000000900
Closed	01109000001100
Closed	01111300001600
Closed	01111300001700
Closed	01111300001900
Closed	01111300002300
Closed	01117200202200
Closed	01117200200100
Closed	01117200200200

Accessory Dwelling Units

Index # - File Name: 1.0022 - Single Family Dwellings Data\_Snohomish County.pdf

Closed	01117200200300
Closed	01117200200400
Closed	01117200200500
Closed	01117200200600
Closed	01117200200700
Closed	01117200200800
Closed	01117200200900
Closed	01117200201000
Closed	01117200201100
Closed	01117200201200
Closed	01117200201300
Closed	01117200201400
Closed	01105300006600
Closed	01105300006700
Closed	01105300006800
Closed	01105300006900
Closed	01105300007000
Closed	01105300007100
Closed	01105300007200
Closed	01105300007300
Closed	01105300007400
Closed	01105300007500
Closed	01105300004100
Closed	01105300004200
Closed	01105300005500
Closed	01105300005800
Closed	01105300005900
Closed	01105300006100
Closed	01105300007700
Closed	01105300007900
Closed	01124200001900
Closed	01124200002000
Closed	01124200002100
Closed	01124200002200
Closed	01124200002300
Closed	01124200002400
Closed	01124200002500
Closed	01124200002600
Closed	01124200002700
Closed	01124200002800
Closed	01124200002900
Closed	01124200003000
Closed	01124200003200
Closed	01124200003300
Closed	01124200003400
Closed	01124200003500
Closed	01124200003600

Accessory Dwelling Units

Index # - File Name: 1.0022 - Single Family Dwellings Data\_Snohomish County.pdf

Closed	01124200003700
Closed	01124200003800
Closed	01124200003900
Closed	01124200004000
Closed	01124200004100
Closed	01124200004200
Closed	01124200004300
Closed	01124200004400
Closed	01124200004500
Closed	01124200004600
Closed	01124200004700
Closed	01124200004800
Closed	01124200004900
Closed	01124200001700
Closed	01124200000800
Closed	01117200206800
Closed	01117200206900
Closed	01124200000300
Closed	01124200000400
Closed	01124200000500
Closed	01117200204700
Closed	01117200204800
Closed	01117200202700
Closed	01117200202800
Closed	01117200205100
Closed	01117200205200
Closed	01117200205300
Closed	01117200205400
Closed	01117200205500
Closed	01117200205600
Closed	01117200205700
Closed	01117200205800
Closed	01117200205900
Closed	01117200206000
Closed	01117200206100
Closed	01117200206200
Closed	01117200206300
Closed	01117200206400
Closed	01117200206500
Closed	01117200206600
Closed	01117200204500
Closed	01117200203600
Closed	01117200203700
Closed	01117200203800
Closed	01117200203900
Closed	01117200204000
Closed	01117200204100

Accessory Dwelling Units

Index # - File Name: 1.0022 - Single Family Dwellings Data\_Snohomish County.pdf

Closed	01117200203200
Closed	01117200203300
Closed	01117200203400
Closed	01117200202500
Closed	01105300000700
Closed	01105300000800
Closed	01105300000900
Closed	01105300001000
Closed	01105300002500
Closed	01105300002600
Closed	01105300002700
Closed	01105300002800
Closed	01105300002900
Closed	01105300003000
Closed	01105300003100
Closed	01105300003200
Closed	01105300003300
Closed	01105300003400
Closed	01105300000500
Closed	01105300003700
Closed	01105300003800
Closed	01105300003900
Closed	01105300004600
Closed	01081200001800
Closed	01081200001500
Closed	01081200000600
Closed	30072800201500
Closed	01079500002500
Closed	01079500002300
Closed	01079500001900
Closed	01079500002000
Closed	01079500002100
Closed	01079500000400
Closed	01079500000500
Closed	01079500000600
Closed	01079500000900
Closed	01079500001000
Closed	01079500001100
Closed	01079500001200
Closed	01079500001300
Closed	01077100000800
Closed	01077100000900
Closed	01077100001500
Closed	01079500000100
Closed	01078700002300
Closed	01086600001200
Closed	01100200000600

Accessory Dwelling Units

Index # - File Name: 1.0022 - Single Family Dwellings Data\_Snohomish County.pdf

Closed	01100200000100
Closed	01100200000200
Closed	01100200000300
Closed	01087900000400
Closed	01087900000500
Closed	01086600003000
Closed	01087700000100
Closed	01086600002700
Closed	01086600002400
Closed	00380900200806
Closed	00380900200806
Closed	00380900200806
Closed	00380900200806
Closed	00380900200806
Closed	00380900200806
Closed	00380900200806
Closed	00380900200806
Closed	01109200001300
Closed	01109200000600
Closed	01109200000200
Closed	01090600000600
Closed	29061700309300
Closed	01090200000100
Closed	01090200000200
Closed	01090200000300
Closed	01090200000400
Closed	01090200000500
Closed	01090200000600
Closed	01090200000700
Closed	01090200000800
Closed	01090200000900
Closed	01090200001000
Closed	01090200001100
Closed	01090200001200
Closed	01090200001300
Closed	01090200001400
Closed	01090200001500
Closed	01090200001600
Closed	01090200001700
Closed	01090200001800
Closed	01090200001900
Closed	01090200002000
Closed	01090200002100
Closed	01090200002200
Closed	01090200002300
Closed	01090200002400
Closed	01090200002500
Closed	01090200002600

Accessory Dwelling Units

Index # - File Name: 1.0022 - Single Family Dwellings Data\_Snohomish County.pdf

Closed	01090200002700
Closed	01090200002800
Closed	01090200002900
Closed	01090200003000
Closed	01090200003100
Closed	01090200003200
Closed	01088100000200
Closed	01087900000700
Closed	01090000000800
Closed	31052000202300
Closed	31052000202400
Closed	31052000202500
Closed	28051200200800
Closed	01088000000800
Closed	01088000000900
Closed	01088000001000
Closed	01088000001100
Closed	01088000001200
Closed	01088000001300
Closed	01088000001400
Closed	01088000001500
Closed	01088000001600
Closed	01088000001700
Closed	01088000001800
Closed	01088000001900
Closed	01088000002000
Closed	01128200000100
Closed	01128200000200
Closed	01128200000300
Closed	01128200000400
Closed	01053400001300
Closed	01053400001400
Closed	31042200203400
Closed	00556600003700
Closed	00556600004000
Closed	00466300000300
Closed	01058000010800
Closed	01058000010900
Closed	01058000012500
Closed	01058000012600
Closed	01058000012700
Closed	01058000012800
Closed	01058000012900
Closed	01058000013000
Closed	01058000013100
Closed	01089100000801
Closed	31053500401700

Accessory Dwelling Units

Index # - File Name: 1.0022 - Single Family Dwellings Data\_Snohomish County.pdf

Closed	01057200000100
Closed	01057200000800
Closed	01057200001100
Closed	01054700002700
Closed	01054700002800
Closed	01054700002900
Closed	01054700003000
Closed	01054700003100
Closed	01072500000800
Closed	27061700402000
Closed	01084300000500
Closed	30051100402300
Closed	01129600000100
Closed	01129600000200
Closed	01129600000300
Closed	01129600000400
Closed	01129600000500
Closed	01129600000600
Closed	01059400000900
Closed	01055800000400
Closed	01055800000600
Closed	01079000000100
Closed	01079000000200
Closed	01079000000400
Closed	01079000000500
Closed	01079000000600
Closed	01079000000700
Closed	01079000000800
Closed	01079000000900
Closed	01079000001000
Closed	01059200001100
Closed	01059200001200
Closed	01063500006800
Closed	01063500006900
Closed	01063500007000
Closed	01063500001700
Closed	01063500000600
Closed	01058200001200
Closed	01058200001300
Closed	01062400001100
Closed	01062400001200
Closed	01062400001300
Closed	01062400001400
Closed	01002500100700
Closed	01010100000100
Closed	01010100000200
Closed	29063200401200



Accessory Dwelling Units

Index # - File Name: 1.0022 - Single Family Dwellings Data\_Snohomish County.pdf

Closed	00590700019300
Closed	28070800200500
Closed	00935400000700
Closed	00935400000800
Closed	00933300002100
Closed	32090700202900
Closed	28061100203700
Closed	01010100004200
Closed	00614800005300
Closed	31061600200300
Closed	00373300300115
Closed	00539000002200
Closed	00588100100811
Closed	00588100100812
Closed	00588100100813
Closed	00588100100814
Closed	00588100100815
Closed	29060200302500
Closed	00403800007602
Closed	29051500400200
Closed	00614700801400
Closed	00960007013200
Closed	00960007013400
Closed	00960007004600
Closed	27062700201500
Closed	00924300000100
Closed	00505100001704
Closed	27073200300700
Closed	00394403904400
Closed	27061700101600
Closed	00889800000300
Closed	00591200100310
Closed	27070500205400
Closed	32063400303200
Closed	30060300101900
Closed	27081800202000
Closed	27071800102700
Closed	27052100400600
Closed	27101700400100
Closed	27070500400100
Closed	27060800300400
Closed	00372601101302
Closed	27053300107600
Closed	27052400302800
Closed	27052500100400
Closed	27052600400800
Closed	00373003100203

Accessory Dwelling Units

Index # - File Name: 1.0022 - Single Family Dwellings Data\_Snohomish County.pdf

Closed	00389400200400
Closed	00389400200400
Closed	00403800009902
Closed	00403800012200
Closed	00414400102300
Closed	00427100006900
Closed	00430400000700
Closed	00630500005600
Closed	00623700005300
Closed	00623700000900
Closed	00556600004300
Closed	00577700504101
Closed	00509200101300
Closed	00373300400205
Closed	28052500100200
Closed	28062200403800
Closed	28050300402400
Closed	00703000002200
Closed	00614800004500
Closed	29060400303400
Closed	29060400101400
Closed	29062500200600
Closed	00442900201602
Closed	00414100000301
Closed	00492300003700
Closed	00573700004900
Closed	00574000011100
Closed	00574200003801
Closed	30062200401500
Closed	30062200200600
Closed	30060600301600
Closed	30060300200600
Closed	30051200401800
Closed	00548200000300
Closed	00625900000900
Closed	00429100001300
Closed	00401100008700
Closed	31041400400600
Closed	31063000204000
Closed	00394401009100
Closed	00394401009600
Closed	31053500402300
Closed	31043500403700
Closed	32063100303500
Closed	32062000401300
Closed	32051400100500
Closed	32090700201100

Accessory Dwelling Units

Index # - File Name: 1.0022 - Single Family Dwellings Data\_Snohomish County.pdf

Closed	00720900001100
Closed	00720900001200
Closed	00630700001400
Closed	00494600201300
Closed	00492400201200
Closed	00568700400402
Closed	00568700400403
Closed	00568700400405
Closed	00587200003400
Closed	31050900201500
Closed	00591200200406
Closed	00611300022100
Closed	00383800001400
Closed	00639500000600
Closed	32063500401300
Closed	32052900102400
Closed	00597400001013
Closed	27052100402400
Closed	32042900103000
Closed	27061800202000
Closed	00499100108200
Closed	00499100200800
Closed	00499100106600
Closed	00563100000608
Closed	00546900005800
Closed	32040400201300
Closed	32040500301500
Closed	32061800400200
Closed	32041000301900
Closed	32061000201800
Closed	32052200400700
Closed	00394401008700
Closed	31063100100200
Closed	31063000301300
Closed	00394510200902
Closed	00417900002500
Closed	00394404300800
Closed	31051900303300
Closed	31042200203700
Closed	31040300200800
Closed	30072900100800
Closed	30063300401200
Closed	30063200203300
Closed	00489200001500
Closed	00489200001600
Closed	00511000009101
Closed	00631600008000

Accessory Dwelling Units

Index # - File Name: 1.0022 - Single Family Dwellings Data\_Snohomish County.pdf

Closed	00622300001400
Closed	00557600000400
Closed	30050100201500
Closed	30050100202800
Closed	00611300015500
Closed	00557500001903
Closed	00590700022901
Closed	00492000100702
Closed	30050200302900
Closed	30040400100300
Closed	30040400100500
Closed	30062100201300
Closed	30061900100900
Closed	00574100011000
Closed	00574200006400
Closed	00574000004600
Closed	00570700100300
Closed	00574400002800
Closed	00614800004300
Closed	00614800002400
Closed	00610300001700
Closed	00570400300402
Closed	00473300500102
Closed	29062000401000
Closed	29063300102300
Closed	29072700100100
Closed	00614800004600
Closed	00690400001500
Closed	00691000000800
Closed	00624500002000
Closed	00675200002700
Closed	00761200000200
Closed	00771300000500
Closed	00775900001300
Closed	28060300301000
Closed	28050200302800
Closed	28060600100900
Closed	28070600300100
Closed	28051600300900
Closed	28061600100700
Closed	28072100300100
Closed	00374600002500
Closed	00374800003602
Closed	00376200001200
Closed	00380900201106
Closed	28053300300300
Closed	00509800001700

Accessory Dwelling Units

Index # - File Name: 1.0022 - Single Family Dwellings Data\_Snohomish County.pdf

Closed	00492600000500
Closed	00492600000600
Closed	00555300400201
Closed	00623700005701
Closed	00623700006100
Closed	00623700003200
Closed	00623700003300
Closed	00629900001000
Closed	00631900000500
Closed	00430400001300
Closed	00442400000600
Closed	00409500003001
Closed	00396300000302
Closed	00403800001601
Closed	00374100200108
Closed	00374100100303
Closed	00374100100304
Closed	27052500403300
Closed	27052500300200
Closed	27053600302800
Closed	00372801700701
Closed	00373002100104
Closed	27070200400400
Closed	27051000302300
Closed	27051100300200
Closed	27051100401900
Closed	00960003903300
Closed	28050300104700
Closed	00869900003000
Closed	00543300006600
Closed	00876200000100
Closed	00394511100700
Closed	00960007009000
Closed	00960007010600
Closed	00960007011000
Closed	00960007011400
Closed	00960007013600
Closed	30073200401000
Closed	28073300202700
Closed	00915000000300
Closed	29051100400900
Closed	28050300403100
Closed	28061200301800
Closed	00473300000701
Closed	30063500101000
Closed	00597400002101
Closed	01040500001200

Accessory Dwelling Units

Index # - File Name: 1.0022 - Single Family Dwellings Data\_Snohomish County.pdf

Closed	01040500000600
Closed	30073200401600
Closed	30073200401700
Closed	32080200404000
Closed	32080200404100
Closed	01042500000500
Closed	00374800003603
Closed	31051700103400
Closed	31051700102300
Closed	01024800000200
Closed	29070900301300
Closed	01010700001100
Closed	31040700400800
Closed	00473300001607
Closed	32040800402200
Closed	00548000301605
Closed	01000400000100
Closed	29063200401100
Closed	29063200401000
Closed	01058200001400
Closed	01058200000100
Closed	01058200000200
Closed	01068500000600
Closed	28051700412200
Closed	29053500402400
Closed	00551600000201
Closed	00551600000202
Closed	00551600000301
Closed	01077200000300
Closed	01077200000400
Closed	01077200000500
Closed	01077200000600
Closed	01077200000700
Closed	01077200000100
Closed	01055500000300
Closed	00394403505600
Closed	00394403502500
Closed	32041000403600
Closed	01053400001800
Closed	32063300101800
Closed	01053400000100
Closed	01053400000200
Closed	28062200200900
Closed	01128200000500
Closed	01128200000600
Closed	01128200000700
Closed	01128200000800

Accessory Dwelling Units

Index # - File Name: 1.0022 - Single Family Dwellings Data\_Snohomish County.pdf

Closed	01128200000900
Closed	28071800302900
Closed	28083000304100
Closed	01090000000200
Closed	01087900000100
Closed	01088100000300
Closed	01088100000400
Closed	01088100000500
Closed	01088100000600
Closed	00608100100307
Closed	27063300402300
Closed	27063300402400
Closed	27063300402600
Closed	27050400102500
Closed	01109200000700
Closed	01109200000800
Closed	01084400001000
Closed	01109200001700
Closed	01128400000300
Closed	01128400000400
Closed	01128400000500
Closed	01128400000600
Closed	01128400000700
Closed	01128400000800
Closed	01128400000900
Closed	01128400001000
Closed	01078700000100
Closed	01078700000200
Closed	01078700002800
Closed	28072600102400
Closed	01078700000400
Closed	01079500000200
Closed	01079500000300
Closed	01079500000700
Closed	01079500002200
Closed	01083700000300
Closed	01083700000700
Closed	01079500003000
Closed	01134000000100
Closed	01134000000200
Closed	01134000000300
Closed	01134000000400
Closed	01134000000500
Closed	01134000000600
Closed	01134000000700
Closed	01134000000800
Closed	01134000000900

Accessory Dwelling Units

Index # - File Name: 1.0022 - Single Family Dwellings Data\_Snohomish County.pdf

Closed	0113400001000
Closed	0113400001100
Closed	0113400001200
Closed	0113400001300
Closed	0113400001400
Closed	0113400001600
Closed	0113400001700
Closed	0113400001800
Closed	0113400001900
Closed	0113400003300
Closed	0113400003400
Closed	0113400003500
Closed	0113400003600
Closed	0113400003700
Closed	0113400003800
Closed	0113400003900
Closed	0113400004000
Closed	01105300004700
Closed	01105300004800
Closed	01105300004900
Closed	01105300005000
Closed	01105300005100
Closed	01105300005200
Closed	01105300005300
Closed	01105300005400
Closed	0110530000600
Closed	0110530000100
Closed	0110530000200
Closed	0110530000300
Closed	0110530000400
Closed	01105300003500
Closed	01105300003600
Closed	01105300001700
Closed	01105300001800
Closed	01105300001900
Closed	01105300002000
Closed	01105300002100
Closed	01105300002200
Closed	01105300002300
Closed	01105300002400
Closed	01105300001100
Closed	01105300001200
Closed	01105300001300
Closed	01105300001400
Closed	01105300001500
Closed	01105300001600
Closed	32091700200900



Accessory Dwelling Units

Index # - File Name: 1.0022 - Single Family Dwellings Data\_Snohomish County.pdf

Closed	31041100202100
Closed	01105300007800
Closed	01105300005600
Closed	01105300005700
Closed	01105300004300
Closed	01105300004400
Closed	01105300004500
Closed	01105300007600
Closed	01109000001200
Closed	01110600000500
Closed	01110600000600
Closed	01117600000800
Closed	01117600000900
Closed	01117600001000
Closed	01117600001100
Closed	01117600001200
Closed	01117600001600
Closed	01117600001700
Closed	01109500001100
Closed	01109500000200
Closed	01109500000300
Closed	01126600000800
Closed	01126600000900
Closed	01126600001000
Closed	01126600001100
Closed	01126600001200
Closed	01126600001300
Closed	01126600001400
Closed	01126600001500
Closed	01126600001600
Closed	01126600001700
Closed	01126600001800
Closed	01126600001900
Closed	01126600002000
Closed	01126600002100
Closed	01126600002200
Closed	01126600002300
Closed	01126600002400
Closed	01126600002500
Closed	01126600002600
Closed	01126600002700
Closed	01126600002800
Closed	01126600002900
Closed	01126600003000
Closed	01126600003100
Closed	01126600000100
Closed	01126600000200

Accessory Dwelling Units

Index # - File Name: 1.0022 - Single Family Dwellings Data\_Snohomish County.pdf

Closed	0112660000300
Closed	0112660000400
Closed	0112660000500
Closed	0112660003700
Closed	29062500300200
Closed	01110500002400
Closed	01110500001300
Closed	01110500000100
Closed	01110500000200
Closed	01101800003000
Closed	01101800003400
Closed	01101800003500
Closed	00454600001200
Closed	27041100403600
Closed	01101800002200
Closed	01101800000600
Closed	01101800000700
Closed	01101800000800
Closed	01101800000900
Closed	01131300002200
Closed	01131300004300
Closed	01131300002600
Closed	01131300002700
Closed	01131300002800
Closed	01131300002900
Closed	01131300003000
Closed	01131300003100
Closed	01131300003200
Closed	01131300003300
Closed	01131300003400
Closed	01131300003500
Closed	01131300003600
Closed	01131300003700
Closed	01131300003800
Closed	01131300003900
Closed	01131300004000
Closed	01131300004100
Closed	27052100306800
Closed	27052100306900
Closed	01127800000800
Closed	27052100306600
Closed	01131300000200
Closed	01131300000300
Closed	01131300000400
Closed	01131300000500
Closed	01131300000600
Closed	01131300000700

Accessory Dwelling Units

Index # - File Name: 1.0022 - Single Family Dwellings Data\_Snohomish County.pdf

Closed	31050400102600
Closed	27061900100400
Closed	01105600000100
Closed	01105600000200
Closed	01105600000300
Closed	01098600002500
Closed	01098600002600
Closed	01098600002700
Closed	01098600002800
Closed	01098600002000
Closed	01098600002100
Closed	01098600002200
Closed	01098600002300
Closed	01098600001700
Closed	01098600001800
Closed	01098600001500
Closed	01098600000900
Closed	01098600001000
Closed	01098600001100
Closed	01098600001200
Closed	01131400000100
Closed	01131400000200
Closed	01131400000300
Closed	01131400000400
Closed	01131400000500
Closed	01131400000600
Closed	01131400000700
Closed	01131400000800
Closed	01131400000900
Closed	01131400001000
Closed	01131400001100
Closed	01096200000700
Closed	01098600000500
Closed	01098600000600
Closed	01098600000700
Closed	01098600000300
Closed	01098600000100
Closed	01096500000600
Closed	01096500000700
Closed	29062000212100
Closed	29062000211800
Closed	01098600003100
Closed	32042700201700
Closed	01133200002400
Closed	01133200002100
Closed	01129100000100
Closed	01133200008300

Accessory Dwelling Units

Index # - File Name: 1.0022 - Single Family Dwellings Data\_Snohomish County.pdf

Closed	01133200008400
Closed	01133200008500
Closed	01133200008600
Closed	01133200008700
Closed	01133200000100
Closed	01133200000200
Closed	01133200000300
Closed	01133200000400
Closed	01133200000500
Closed	01133200000600
Closed	01133200000700
Closed	01133200000800
Closed	01133200000900
Closed	01133200001000
Closed	01133200001100
Closed	01133200001200
Closed	01133200001300
Closed	01133200001400
Closed	01133200001500
Closed	01133200001600
Closed	01133200001700
Closed	01133200001800
Closed	01131800000200
Closed	01131800000300
Closed	01131800000400
Closed	01131800000500
Closed	01131800000600
Closed	01131800000700
Closed	01131800000800
Closed	01131800000900
Closed	01131800001000
Closed	01131800001100
Closed	01131800001200
Closed	01131800001300
Closed	01131800001400
Closed	01131800001500
Closed	01131800001600
Closed	01131800001700
Closed	01131800001800
Closed	01131800001900
Closed	01131800002000
Closed	01131800002100
Closed	01131800002200
Closed	01131800002300
Closed	01131800002400
Closed	01131800002500
Closed	27063100300200

Accessory Dwelling Units

Index # - File Name: 1.0022 - Single Family Dwellings Data\_Snohomish County.pdf

Closed	01133100000600
Closed	01133100000700
Closed	01133100000800
Closed	01133100000900
Closed	01133100001000
Closed	01133100001100
Closed	31050500203000
Closed	28081800302400
Closed	28081800302300
Closed	30050100402800
Closed	31042200203900
Closed	31042200203800
Closed	32053100402400
Closed	00373002800304
Closed	32062800203100
Closed	01132400009500
Closed	01132400009600
Closed	01132400009700
Closed	01132400009800
Closed	01132400009900
Closed	01132400010000
Closed	01132400010100
Closed	01132400010200
Closed	01132400010300
Closed	01132400010400
Closed	01132400010500
Closed	01132400010600
Closed	01132400011500
Closed	01132400011600
Closed	01132400011700
Closed	01132400013600
Closed	01132400011800
Closed	01132400011900
Closed	01132400012000
Closed	01132400012100
Closed	01132400012200
Closed	01132400012300
Closed	01132400012400
Closed	01132400012500
Closed	01132400012600
Closed	01132400012700
Closed	01132400012800
Closed	01132400012900
Closed	01132400013000
Closed	01132400013100
Closed	01132400013200
Closed	01132400013300

Accessory Dwelling Units

Index # - File Name: 1.0022 - Single Family Dwellings Data\_Snohomish County.pdf

Closed	01132400013400
Closed	01132400013500
Closed	01133200002800
Closed	01133200002900
Closed	01133200003000
Closed	01133200003100
Closed	01133200003200
Closed	01133200003300
Closed	01133200003400
Closed	01133200003500
Closed	01133200003600
Closed	01133200003700
Closed	01133200003800
Closed	01133200003900
Closed	01133200004000
Closed	01133200004100
Closed	01133200004200
Closed	01133200009000
Closed	29051100204000
Closed	01131800000100
Closed	27052100404100
Closed	32052200402400
Closed	30062000301900
Closed	01134800000500
Closed	01134800001600
Closed	01134800001700
Closed	01134800001900
Closed	01134800002000
Closed	01134800002100
Closed	00409500002700
Closed	00374900007806
Closed	00374900007807
Closed	00374900007808
Closed	00374900007809
Closed	01134800001100
Closed	01134800001200
Closed	01134800001300
Closed	01134800001400
Closed	01134800003000
Closed	01134800003100
Closed	01134800003200
Closed	32053500302400
Closed	32052800201400
Closed	00394403702600
Closed	01134300002000
Closed	01134300002100
Closed	01134300002200

Accessory Dwelling Units

Index # - File Name: 1.0022 - Single Family Dwellings Data\_Snohomish County.pdf

Closed	01134300002300
Closed	01134300002400
Closed	00394403503000
Closed	01134300002900
Closed	01134300003300
Closed	01134300003400
Closed	01134300003500
Closed	01134300003100
Closed	01134300003700
Closed	01132100001800
Closed	01132100001900
Closed	01132100002000
Closed	01132100002100
Closed	01132100002200
Closed	01132100002300
Closed	01132100002400
Closed	01132100002500
Closed	01129800000100
Closed	01132400008300
Closed	01132400008400
Closed	01132700006600
Closed	01132700006700
Closed	01132700006800
Closed	01132700006900
Closed	01132700007000
Closed	01132700007100
Closed	01132700007200
Closed	01132700007300
Closed	01132700007400
Closed	01132700007500
Closed	01132700007600
Closed	01132700007700
Closed	01132700007800
Closed	01132700007900
Closed	01132700008000
Closed	01132700002800
Closed	01132700002900
Closed	01132700003000
Closed	01132700003100
Closed	01132700003200
Closed	01132700003300
Closed	01132700003400
Closed	01132700003500
Closed	01132700003600
Closed	01132700003700
Closed	01132700003800
Closed	01132700003900

Accessory Dwelling Units

Index # - File Name: 1.0022 - Single Family Dwellings Data\_Snohomish County.pdf

Closed	01132700004000
Closed	01132700004100
Closed	01132700004200
Closed	01132700004300
Closed	01132700004400
Closed	01132700004700
Closed	01132700004800
Closed	01132700004900
Closed	01132700005000
Closed	01132700005100
Closed	01132700005200
Closed	01132700005300
Closed	01132700005400
Closed	01132700005500
Closed	01132700005600
Closed	01132700005700
Closed	01132700005800
Closed	01132700005900
Closed	01132700006000
Closed	01132700006100
Closed	01132700006200
Closed	01132700006300
Closed	01132700006400
Closed	01132700008600
Closed	01132700008700
Closed	01132700008800
Closed	01132700008900
Closed	01132700009000
Closed	01132400000600
Closed	01132400000700
Closed	01132400000800
Closed	01132400000900
Closed	01132400001000
Closed	01132400001100
Closed	01132400001200
Closed	01132400001300
Closed	01132400001400
Closed	01132400001500
Closed	01132400001600
Closed	01132400001700
Closed	01132400001800
Closed	01132400001900
Closed	01132400002000
Closed	01132400002100
Closed	01132400002200
Closed	01132400002300
Closed	01132400002400



Accessory Dwelling Units

Index # - File Name: 1.0022 - Single Family Dwellings Data\_Snohomish County.pdf

Closed	01132400002500
Closed	01132400002600
Closed	01132400002700
Closed	01132400002800
Closed	01132400002900
Closed	01132400003000
Closed	01132400003100
Closed	01132400003200
Closed	01132400003300
Closed	01132400003400
Closed	01132400003500
Closed	01132400003600
Closed	01132400003700
Closed	01132400003800
Closed	01132400003900
Closed	01132400004000
Closed	01132400004100
Closed	01132400004200
Closed	01129800000400
Closed	01129800000500
Closed	01129800000600
Closed	01129800000700
Closed	01129800000800
Closed	01129800000900
Closed	01129800001000
Closed	01129800001100
Closed	01132600000300
Closed	01132600000400
Closed	01132600000500
Closed	01132600000600
Closed	01132600000700
Closed	01132600000800
Closed	01132600000900
Closed	01132600001000
Closed	01132600001100
Closed	01132600001200
Closed	01132600001300
Closed	01132600001400
Closed	01132600001500
Closed	01132600001800
Closed	01132600001900
Closed	01132600002000
Closed	01132600002100
Closed	01132600002300
Closed	01132600002400
Closed	01132600002500
Closed	01132600002600

Accessory Dwelling Units

Index # - File Name: 1.0022 - Single Family Dwellings Data\_Snohomish County.pdf

Closed	01132700000100
Closed	01132700000200
Closed	01132700000300
Closed	01132700000400
Closed	01132700000500
Closed	01132700000600
Closed	01132700001100
Closed	01132700001200
Closed	01132700001300
Closed	01132700001400
Closed	01132700001500
Closed	01132700001600
Closed	01132700001700
Closed	01132700001800
Closed	01132700001900
Closed	01132700002000
Closed	01132700002100
Closed	01131500000700
Closed	01131500001000
Closed	01131500001100
Closed	01131500001200
Closed	01131500001300
Closed	01131500001400
Closed	01131500001500
Closed	00464200000400
Closed	00587400001201
Closed	00551500002800
Closed	27052100307600
Closed	27052100307700
Closed	27052100307800
Closed	27052100307900
Closed	27052100308100
Closed	01132100000300
Closed	01132100000400
Closed	01132100000600
Closed	01132100000700
Closed	01132100000800
Closed	01132100000900
Closed	01132100001000
Closed	01132100001100
Closed	01129100000600
Closed	01129100000700
Closed	01129100000800
Closed	01129100000900
Closed	01129100001000
Closed	01129100001100
Closed	01129100001200

Accessory Dwelling Units

Index # - File Name: 1.0022 - Single Family Dwellings Data\_Snohomish County.pdf

Closed	00614700301800
Closed	00403800011302
Closed	00374100400404
Closed	01132300000100
Closed	01132300000200
Closed	01132300000300
Closed	01132300000400
Closed	01132300000500
Closed	01132300000600
Closed	01132300001300
Closed	27063300400100
Closed	01131600003600
Closed	01131600003700
Closed	01131600003800
Closed	01131600003900
Closed	32091300102200
Closed	01134300003900
Closed	00374600000501
Closed	01135000001000
Closed	01135000001100
Closed	01135000001200
Closed	01135000001300
Closed	01136100004400
Closed	01136100004500
Closed	01136100004600
Closed	01136100004700
Closed	01136100007000
Closed	01136100007100
Closed	01136000000900
Closed	01136000001000
Closed	00374100200103
Closed	01135900000100
Closed	01135900003500
Closed	01135900003600
Closed	01135900003200
Closed	01024900000602
Closed	00461000500810
Closed	00614800004700
Closed	00614800004900
Closed	01122100000500
Closed	28050300202400
Closed	00614800004800
Closed	00614800005000
Closed	01124600000200
Closed	01131000000100
Closed	01131000000200
Closed	01131000000300

Accessory Dwelling Units

Index # - File Name: 1.0022 - Single Family Dwellings Data\_Snohomish County.pdf

Closed	01123600004400
Closed	01123600004500
Closed	01123600004600
Closed	01123600004800
Closed	01123600004900
Closed	01123600005000
Closed	01123600005100
Closed	01123600006000
Closed	01123600006100
Closed	01109500002200
Closed	01123600007900
Closed	01123600008000
Closed	01123600008200
Closed	01123600004700
Closed	01124700000100
Closed	01123600006800
Closed	01123600006900
Closed	01123600007000
Closed	01123600007100
Closed	01123600007200
Closed	01124700000300
Closed	31042700306600
Closed	01126200001900
Closed	01126200002000
Closed	01126200002100
Closed	01126200002200
Closed	01126200001100
Closed	01126200001200
Closed	01126200001300
Closed	01126700007400
Closed	01126700007500
Closed	01126700007600
Closed	01126700004600
Closed	01126700005200
Closed	01126700004800
Closed	01126700004900
Closed	01126700002700
Closed	01126700002800
Closed	01126700002900
Closed	01126700003000
Closed	01126700003100
Closed	01126700003200
Closed	01126700003300
Closed	01126700003500
Closed	01126700003600
Closed	01126700003700
Closed	01126700003800

Accessory Dwelling Units

Index # - File Name: 1.0022 - Single Family Dwellings Data\_Snohomish County.pdf

Closed	01126700003900
Closed	01126700004000
Closed	01126700004100
Closed	01126700004200
Closed	01126700004300
Closed	01126700004400
Closed	01127000001100
Closed	01127000001200
Closed	01127000001300
Closed	01126700005500
Closed	01126700005600
Closed	01126700005700
Closed	01126700005800
Closed	01126700005900
Closed	01126700006000
Closed	01126700006100
Closed	01126700006200
Closed	01126700006300
Closed	01126700006400
Closed	01126700006500
Closed	01126700006600
Closed	01126700006700
Closed	01126700006800
Closed	01126700006900
Closed	01126700007000
Closed	01126700007100
Closed	01127000004700
Closed	01127000004800
Closed	01127000004900
Closed	01127000005000
Closed	01127000005100
Closed	01127000005200
Closed	01127000005300
Closed	01127000005400
Closed	01127000005500
Closed	01127000005600
Closed	01126700000100
Closed	01126700000200
Closed	01126700000300
Closed	01126700000400
Closed	01126700000500
Closed	01126700000600
Closed	01126700000700
Closed	01126700000800
Closed	01126700000900
Closed	01126700001000
Closed	01126900000100

Accessory Dwelling Units

Index # - File Name: 1.0022 - Single Family Dwellings Data\_Snohomish County.pdf

Closed	0112690000200
Closed	0112690000300
Closed	0112690000400
Closed	0112690000500
Closed	0112690000600
Closed	0112690000700
Closed	0112690000800
Closed	0112690000900
Closed	0112690001000
Closed	0113160000100
Closed	0113160000200
Closed	0113160000300
Closed	0113160000400
Closed	0113160000500
Closed	0113160000600
Closed	0113160000700
Closed	0113160000800
Closed	0113160000900
Closed	0113160001000
Closed	0113160001100
Closed	0112810000100
Closed	01125900002300
Closed	01126900003800
Closed	01126900003900
Closed	01126900004200
Closed	01126900004300
Closed	01126900004400
Closed	01126900004500
Closed	01126900004600
Closed	01126900004700
Closed	01126900004800
Closed	01126900004900
Closed	01128100003700
Closed	01128100003800
Closed	01128100002500
Closed	01128100002600
Closed	01128100002700
Closed	01128100002800
Closed	0112810000300
Closed	0112810000400
Closed	0112810000500
Closed	0112810000600
Closed	0112810000700
Closed	0112810000800
Closed	0112810000900
Closed	01128100001000
Closed	01125600000200

Accessory Dwelling Units

Index # - File Name: 1.0022 - Single Family Dwellings Data\_Snohomish County.pdf

Closed	0112560000300
Closed	01126200006300
Closed	01126200006400
Closed	01126200006500
Closed	01126200006600
Closed	01126200006700
Closed	01126200006800
Closed	01126200006900
Closed	01126200007000
Closed	01126200007100
Closed	01126200007200
Closed	01126200007300
Closed	01126200007400
Closed	01126200007500
Closed	01126200007600
Closed	01126200005600
Closed	01126200006000
Closed	01126200006100
Closed	01126200004000
Closed	01126200002700
Closed	01126700008000
Closed	01126700008100
Closed	31043100200300
Closed	01128600000100
Closed	01126200004500
Closed	27070100402700
Closed	01125900005400
Closed	01125900005500
Closed	01125900004400
Closed	01125900001600
Closed	01125900003700
Closed	01125900003800
Closed	01125900001800
Closed	0051100000201
Closed	01125600000100
Closed	28070800202100
Closed	28070800202200
Closed	28070800202300
Closed	01128600000800
Closed	01128600000300
Closed	01125600000500
Closed	01125600000600
Closed	01125600000700
Closed	01125600000800
Closed	01126400000700
Closed	01126700001100
Closed	01126700001200

Accessory Dwelling Units

Index # - File Name: 1.0022 - Single Family Dwellings Data\_Snohomish County.pdf

Closed	01126700001300
Closed	01126700001400
Closed	01126700001500
Closed	01126700001600
Closed	01126700001700
Closed	01126700001800
Closed	01126700001900
Closed	01126700002000
Closed	01126700002100
Closed	01126700002200
Closed	01126700002300
Closed	01126700002400
Closed	01126700002500
Closed	01126700002600
Closed	00394400802601
Closed	01126700005000
Closed	01126700005100
Closed	01126700005300
Closed	01126700005400
Closed	30063300403700
Closed	30063300403800
Closed	29061500302100
Closed	01109500001500
Closed	32063000302100
Closed	29060200100400
Closed	00511300001400
Closed	00635000000200
Closed	01135900003300
Closed	01135900003400
Closed	01139800001000
Closed	00536300002701
Closed	00403900020004
Closed	00403900020005
Closed	00403900020006
Closed	31040100200200
Closed	01138600000100
Closed	01138600000200
Closed	01138600000300
Closed	01138600000400
Closed	01138600000500
Closed	01138600000600
Closed	01138600000800
Closed	01138600001300
Closed	01138600001500
Closed	01138600001600
Closed	01138600001700
Closed	01138600001800



Accessory Dwelling Units

Index # - File Name: 1.0022 - Single Family Dwellings Data\_Snohomish County.pdf

Closed	01138600001900
Closed	01139800003000
Closed	01139800003100
Closed	01139800003200
Closed	01139800003300
Closed	01139800003400
Closed	01139800003500
Closed	01139800003600
Closed	01139800003700
Closed	01139800003800
Closed	01139800003900
Closed	01139800004000
Closed	01139800004100
Closed	01139800004200
Closed	01139800004800
Closed	01139800004900
Closed	01139800005000
Closed	01139800005100
Closed	01139800005200
Closed	01139800005300
Closed	01139800005400
Closed	01139800005500
Closed	01139800005600
Closed	01139800005700
Closed	01139800005800
Closed	01139800005900
Closed	01139800006000
Closed	01139800006100
Closed	01139800006200
Closed	01139800006300
Closed	01139800006400
Closed	01139800006500
Closed	01140100006000
Closed	01140100007000
Closed	01140100008000
Closed	01140100009000
Closed	01140100001000
Closed	01140100001600
Closed	01140100002600
Closed	01140100002700
Closed	01140100002800
Closed	01140100002900
Closed	01140100003000
Closed	01140100003100
Closed	01140100003200
Closed	01140100003300
Closed	01140100003400

Accessory Dwelling Units

Index # - File Name: 1.0022 - Single Family Dwellings Data\_Snohomish County.pdf

Closed	01140100003500
Closed	01135900001600
Closed	01135900001700
Closed	01135900001800
Closed	01135900001900
Closed	01135900002000
Closed	00394405005401
Closed	28073000402500
Closed	01137100000300
Closed	01137100000400
Closed	01137100000500
Closed	01137100000600
Closed	01137100000700
Closed	01137100000800
Closed	01137100000900
Closed	01137100001000
Closed	01137100001100
Closed	01137100001200
Closed	01137100001300
Closed	01137100001400
Closed	01137100001500
Closed	01137100001600
Closed	01137100002200
Closed	01137100002300
Closed	01137100002400
Closed	01137100002500
Closed	01137100002600
Closed	01137100002700
Closed	01137100002800
Closed	01137100002900
Closed	00374101000706
Closed	00374101000707
Closed	00374101000708
Closed	00374101000709
Closed	00374101000710
Closed	00374101000711
Closed	00374101000712
Closed	00374101000713
Closed	01135900003700
Closed	01135900003800
Closed	27051500202100
Closed	27051500202100
Closed	00625300002802
Closed	01135900002200
Closed	01135900002300
Closed	01135900002400
Closed	01135900002500

Accessory Dwelling Units

Index # - File Name: 1.0022 - Single Family Dwellings Data\_Snohomish County.pdf

Closed	01135900002600
Closed	01135900002700
Closed	01135900002800
Closed	01135900002900
Closed	01135900003000
Closed	01135900000200
Closed	01135900000300
Closed	01135900000400
Closed	01135900000500
Closed	01135900000600
Closed	00486300000401
Closed	00486300000402
Closed	00373000702103
Closed	00373000702104
Closed	01135900001200
Closed	01135900001300
Closed	01135900001400
Closed	30061900101700
Closed	01137500000800
Closed	01137500000900
Closed	01137500001000
Closed	01136000001100
Closed	01136000001200
Closed	00373003100113
Closed	00373003100114
Closed	27071100300700
Closed	01136100007200
Closed	01138200000900
Closed	01138200001000
Closed	01138200001100
Closed	01138200001200
Closed	01138200001300
Closed	01138200001400
Closed	01138200001500
Closed	01138200001600
Closed	01138200001700
Closed	01138200001800
Closed	01138200001900
Closed	01138200002000
Closed	01136100005500
Closed	01136100005600
Closed	01136100005700
Closed	01136100005800
Closed	01136100005900
Closed	01136100006000
Closed	01136100006100
Closed	01136100006200

Accessory Dwelling Units

Index # - File Name: 1.0022 - Single Family Dwellings Data\_Snohomish County.pdf

Closed	01136100006300
Closed	01136100006400
Closed	01136100006500
Closed	01136100006600
Closed	01136100006700
Closed	01136100006800
Closed	01136100006900
Closed	01135000001400
Closed	01135000001500
Closed	01135000002000
Closed	01135000000500
Closed	01135000000800
Closed	01135000000900
Closed	01134300004000
Closed	01134300004100
Closed	01134300004200
Closed	01134300004300
Closed	01134300004400
Closed	01134300004600
Closed	01136100000100
Closed	01136100000200
Closed	01136100000300
Closed	01136100000400
Closed	01136100000500
Closed	01136100000600
Closed	01136100000700
Closed	01136100000800
Closed	01136100000900
Closed	01136100001000
Closed	01136100001100
Closed	01136100001200
Closed	01136100001300
Closed	01136100001400
Closed	01136100001500
Closed	01136100001600
Closed	01136100001700
Closed	01136100001800
Closed	01136100001900
Closed	01136100002000
Closed	01136100002100
Closed	01136100002200
Closed	01136100002300
Closed	01136100002400
Closed	01136100002500
Closed	01136100002600
Closed	01136100002800
Closed	01136100002900

Accessory Dwelling Units

Index # - File Name: 1.0022 - Single Family Dwellings Data\_Snohomish County.pdf

Closed	01136100003100
Closed	01136100003200
Closed	01136100003300
Closed	01136100003400
Closed	01136100003500
Closed	01136100003600
Closed	01136100003700
Closed	01136100003800
Closed	01136100003900
Closed	01136100004000
Closed	01136100004100
Closed	01136100004200
Closed	01136100004300
Closed	01139800001900
Closed	01139800002000
Closed	01139800002100
Closed	01139800002200
Closed	01139800002300
Closed	01139800002400
Closed	01139800002500
Closed	01139800002600
Closed	01139800002700
Closed	01139800006900
Closed	01136700000100
Closed	01136700000200
Closed	01136700000300
Closed	01136700000400
Closed	01136700000500
Closed	01136700000600
Closed	01136700000800
Closed	01136700000900
Closed	01136700001000
Closed	27050900207000
Closed	00374100500106
Closed	00374100500107
Closed	00374100500108
Closed	00374100500109
Closed	00374100500110
Closed	00374100500111
Closed	00374100500112
Closed	00374100500113
Closed	00374100500114
Closed	01138400000100
Closed	01138400000300
Closed	01138400000400
Closed	01138400000500
Closed	01138400000600

Accessory Dwelling Units

Index # - File Name: 1.0022 - Single Family Dwellings Data\_Snohomish County.pdf

Closed	01138400000700
Closed	01138400000800
Closed	01138400000900
Closed	01138400001000
Closed	01138400001100
Closed	01138400001200
Closed	01138400001300
Closed	01138400001400
Closed	01138400001900
Closed	01138400002000
Closed	01138400002100
Closed	01138400002200
Closed	01138400002300
Closed	01138400002600
Closed	01135600000900
Closed	01142300000900
Closed	01142300001000
Closed	01142300001100
Closed	01142300001200
Closed	01142300001300
Closed	01142300001400
Closed	31041200300100
Closed	27062100301200
Closed	28050300405100
Closed	32051400200800
Closed	28073100402800
Closed	27062700402200
Closed	01139500000100
Closed	01139500000300
Closed	01139500000800
Closed	01139500001100
Closed	01139500001200
Closed	01139500001300
Closed	01139500001400
Closed	01139500001500
Closed	01139500001600
Closed	01139500001800
Closed	01139500001900
Closed	01139500002000
Closed	01139500002100
Closed	01139500002200
Closed	29062000304600
Closed	29062000304700
Closed	29062000304800
Closed	29062000304900
Closed	29062000305000
Closed	29062000305100

Accessory Dwelling Units

Index # - File Name: 1.0022 - Single Family Dwellings Data\_Snohomish County.pdf

Closed	27050900207200
Closed	27050900207100
Closed	00394401602900
Closed	00604100000606
Closed	00500100000600
Closed	01140300000600
Closed	01140300000700
Closed	01140300000800
Closed	01140300000900
Closed	01140300001000
Closed	01140300001200
Closed	01140300001300
Closed	01140300001800
Closed	01140300001900
Closed	30051400302100
Closed	01140300002300
Closed	01140300002400
Closed	01139200000500
Closed	01139200000600
Closed	01139200000700
Closed	01139200000800
Closed	01139200000900
Closed	01139200001000
Closed	01139200001100
Closed	01139200001200
Closed	01139200001300
Closed	01139200001400
Closed	01139200001600
Closed	01139200001700
Closed	01139200001800
Closed	01139200001900
Closed	01139200002000
Closed	01139200002100
Closed	01139200003500
Closed	27070200402000
Closed	32041500303100
Closed	32041500303200
Closed	27052800211200
Closed	27052800211300
Closed	27052800211400
Closed	27052800211500
Closed	27052800211600
Closed	27063200404200
Closed	29060400401000
Closed	31041800101100
Closed	27043500100900
Closed	27063400101600

Accessory Dwelling Units

Index # - File Name: 1.0022 - Single Family Dwellings Data\_Snohomish County.pdf

Closed	01131600001400
Closed	01131600001600
Closed	01131600001700
Closed	01131600001800
Closed	01131600002000
Closed	01131600002100
Closed	01131600002900
Closed	01131600003200
Closed	01131600003400
Closed	01131600004200
Closed	32052000101500
Closed	00582600400600
Closed	01132700002500
Closed	01132400004300
Closed	01132400004400
Closed	01132400004500
Closed	01132400004600
Closed	01132400004700
Closed	01132400004800
Closed	01132400004900
Closed	01132400005000
Closed	01132400005100
Closed	01132400005200
Closed	01132400005300
Closed	01132400005400
Closed	01132400005500
Closed	01132400005600
Closed	01132400005700
Closed	01132400005800
Closed	01132400005900
Closed	01132400006000
Closed	01132400006100
Closed	01132400006200
Closed	01132400006300
Closed	01132400006400
Closed	01132400006500
Closed	01132400006600
Closed	01132400006700
Closed	01132400006800
Closed	01132400006900
Closed	01132400007000
Closed	01132400007100
Closed	01132400007200
Closed	01132400007300
Closed	01132400007400
Closed	01132400007500
Closed	01132400007600



Accessory Dwelling Units

Index # - File Name: 1.0022 - Single Family Dwellings Data\_Snohomish County.pdf

Closed	01132400007700
Closed	01132400007800
Closed	01132400007900
Closed	01132400008000
Closed	01132400008100
Closed	01132400008200
Closed	01132700006500
Closed	01132700004500
Closed	01132700004600
Closed	01132700008100
Closed	01132700008200
Closed	01132700008300
Closed	01132700008400
Closed	01132700008500
Closed	01132400008500
Closed	01132400008600
Closed	01132400008700
Closed	01132400008800
Closed	01132400008900
Closed	01132400009000
Closed	01132400009100
Closed	01132400009200
Closed	01132400009300
Closed	01132400009400
Closed	01134300003600
Closed	01134300003000
Closed	00538000003500
Closed	00538000003500
Closed	01134300001500
Closed	01134300001600
Closed	01134300001600
Closed	01134300001700
Closed	01134300001800
Closed	01134300001900
Closed	01134300005000
Closed	01134300005100
Closed	01134300005200
Closed	01134300005300
Closed	01134300005400
Closed	01134300002500
Closed	01134300002600
Closed	01134300002700
Closed	01134300002800
Closed	32053500302500
Closed	01134800003500
Closed	01134800001500
Closed	01135500001000

Accessory Dwelling Units

Index # - File Name: 1.0022 - Single Family Dwellings Data\_Snohomish County.pdf

Closed	01135500001100
Closed	01135500001200
Closed	01135500001300
Closed	01135500001400
Closed	01135500001500
Closed	01135500001600
Closed	01135500001700
Closed	01135500001800
Closed	01135500001900
Closed	01135500002000
Closed	01135500002100
Closed	01135500002200
Closed	01135500002300
Closed	01135500002400
Closed	01135500002500
Closed	01135500002600
Closed	01135500002700
Closed	01135500002800
Closed	01135500002900
Closed	01135500003000
Closed	01135500003100
Closed	01135500003200
Closed	01135500003300
Closed	01135500003400
Closed	01135500003500
Closed	01135500003600
Closed	01135500003700
Closed	01135500003800
Closed	01135500003900
Closed	01135500004000
Closed	01135500004100
Closed	01135500004200
Closed	01135500004300
Closed	01135500004400
Closed	01135500004500
Closed	01135500004600
Closed	01135500004700
Closed	01135500004800
Closed	01135500004900
Closed	01135500005000
Closed	01135500005100
Closed	01135500005200
Closed	01135500005300
Closed	01135500005400
Closed	01135500005500
Closed	01135500005600
Closed	01135500005700

Accessory Dwelling Units

Index # - File Name: 1.0022 - Single Family Dwellings Data\_Snohomish County.pdf

Closed	01135500005800
Closed	01135500005900
Closed	01134800002200
Closed	01134800002300
Closed	01134800002400
Closed	01134800002500
Closed	01134800002600
Closed	01134800002700
Closed	01134800002900
Closed	01134800000800
Closed	01134800000900
Closed	01134800000100
Closed	01137400000100
Closed	01137400000700
Closed	01137400001100
Closed	00373000700402
Closed	30052500402500
Closed	00394405005402
Closed	32053200200400
Closed	01142900000100
Closed	01133200004300
Closed	01133200004400
Closed	01133200004500
Closed	01133200004600
Closed	01133200004700
Closed	01133200004800
Closed	01133200004900
Closed	01133200005000
Closed	01133200005100
Closed	01133200005200
Closed	01133200005300
Closed	01133200005400
Closed	01133200005500
Closed	01133200005600
Closed	01133200005700
Closed	01133200005800
Closed	01133200005900
Closed	01133200006000
Closed	01133200006100
Closed	01133200006200
Closed	01133200006300
Closed	01133200006400
Closed	01133200006500
Closed	01133200006600
Closed	01133200006700
Closed	01133200006800
Closed	01133200006900

Accessory Dwelling Units

Index # - File Name: 1.0022 - Single Family Dwellings Data\_Snohomish County.pdf

Closed	01132400010700
Closed	01132400010800
Closed	01132400010900
Closed	01132400011000
Closed	01132400011100
Closed	01132400011200
Closed	01132400011300
Closed	01132400011400
Closed	28081800303000
Closed	28081800302800
Closed	28081800303100
Closed	28081800302700
Closed	01133200001900
Closed	01133200002000
Closed	01133200008800
Closed	01133200008900
Closed	01133200002200
Closed	01133200002300
Closed	01133200002500
Closed	01133200002600
Closed	01133200002700
Closed	01126300000601
Closed	01142400004200
Closed	01142400004300
Closed	01142400004400
Closed	01142400004500
Closed	01142400004600
Closed	01142400004700
Closed	01142400004800
Closed	01142400004900
Closed	01142400005000
Closed	01142400005100
Closed	01142400005200
Closed	01142400005300
Closed	01142400005400
Closed	01142400005500
Closed	01142400005600
Closed	01142400002200
Closed	01142400002300
Closed	01142400002400
Closed	01142400002500
Closed	01142400001800
Closed	27052500400900
Closed	27062100301200
Closed	29063300301000
Closed	00512000207400
Closed	32053500301900

Accessory Dwelling Units

Index # - File Name: 1.0022 - Single Family Dwellings Data\_Snohomish County.pdf

Closed	00509300002503
Closed	00509300002504
Closed	00509300002505
Closed	00509300002506
Closed	00509300002507
Closed	01144300000200
Closed	00394403502201
Closed	01140800000500
Closed	00394403708500
Closed	00457100001803
Closed	00505100001100
Closed	01145000000500
Closed	00509300003500
Closed	28083400200600
Closed	27052100308200
Closed	01142900000200
Closed	01142900000300
Closed	01142900004200
Closed	01142900004300
Closed	27062900302100
Closed	00376800002900
Closed	01096500000800
Closed	01131300000100
Closed	32042200103500
Closed	01131300000800
Closed	01131300000900
Closed	01131300001000
Closed	01131300001100
Closed	01131300001200
Closed	01131300001300
Closed	01131300001400
Closed	01131300001500
Closed	01131300001600
Closed	01131300001700
Closed	01131300001800
Closed	01131300001900
Closed	01131300002000
Closed	01131300002100
Closed	01131300004200
Closed	01131300004400
Closed	01131300004500
Closed	01131300004600
Closed	01131300004700
Closed	32091700200800
Closed	01131300002300
Closed	01131300002400
Closed	01131300002500

Accessory Dwelling Units

Index # - File Name: 1.0022 - Single Family Dwellings Data\_Snohomish County.pdf

Closed	32042700402900
Closed	28060200203700
Closed	31060500203500
Closed	32061600400800
Closed	01109500002900
Closed	01128000000100
Closed	01128000000200
Closed	01128000000300
Closed	01128000001200
Closed	01128000001300
Closed	01128000001400
Closed	01128000001000
Closed	01141000001400
Closed	31041100202200
Closed	31041100202300
Closed	31041100202400
Closed	01105300001600
Closed	30061400201300
Closed	01141000000100
Closed	01141000000200
Closed	01141000000300
Closed	01141000000400
Closed	01141000000500
Closed	01141000000600
Closed	01141000000700
Closed	01141000000800
Closed	01141000000900
Closed	01141000001000
Closed	01141000001100
Closed	01134000002000
Closed	01134000002100
Closed	01134000002200
Closed	01134000002300
Closed	01134000002400
Closed	01134000002500
Closed	01134000002600
Closed	01134000002700
Closed	01134000002800
Closed	01134000002900
Closed	01134000003000
Closed	01134000003100
Closed	01134000003200
Closed	01134000001500
Closed	00413900002400
Closed	00538000003500
Closed	00538000003500
Closed	00538000003500

Accessory Dwelling Units

Index # - File Name: 1.0022 - Single Family Dwellings Data\_Snohomish County.pdf

Closed	0053800003500
Closed	0053800003500
Closed	0053800003500
Closed	0053800003500
Closed	0053800003500
Closed	0053800003500
Closed	0053800003500
Closed	0053800003500
Closed	0053800003500
Closed	0053800003500
Closed	0053800003500
Closed	0053800003500
Closed	0053800003500
Closed	0053800003500
Closed	0053800003500
Closed	29062000211500
Closed	29062000211600
Closed	29062000211700
Closed	27063300402700
Closed	27063300402500
Closed	01091900000100
Closed	01091900000200
Closed	01091900000300
Closed	01091900000400
Closed	01091900000500
Closed	01091900000600
Closed	01091900000700
Closed	01091900000800
Closed	01091900001000
Closed	01091900001100
Closed	01088100000700
Closed	29063000105000
Closed	00533800001002
Closed	32051800202000
Closed	01053400000300
Closed	01053400002800
Closed	00556600003800
Closed	00556600003900
Closed	00556600004200
Closed	29062500400800
Closed	01075700000300
Closed	31050100102900
Closed	01084300000200
Closed	31041000408300
Closed	01061500004000
Closed	01061500002800
Closed	31040100200200

Accessory Dwelling Units

Index # - File Name: 1.0022 - Single Family Dwellings Data\_Snohomish County.pdf

Closed	01056400000300
Closed	01056400001300
Closed	31041400402400
Closed	29063200401300
Closed	32052100201200
Closed	00402400000300
Closed	00954400000300
Closed	31051900200900
Closed	27070400301500
Closed	32071700300100
Closed	00935400001000
Closed	00464200002800
Closed	28051100100700
Closed	32042700401100
Closed	31060400102800
Closed	28070800300100
Closed	28070800400300
Closed	27070700402800
Closed	29052600101900
Closed	01024800000200
Closed	01024800000300
Closed	31051700103500
Closed	28072800304000
Closed	29061600301400
Closed	01043500002600
Closed	01043500000500
Closed	01043500000600
Closed	01043500000100
Closed	01043500000800
Closed	01043500000900
Closed	01043500003200
Closed	01043500002900
Closed	01043500003000
Closed	30073100402000
Closed	30073100402100
Closed	30073100402200
Closed	30073200402000
Closed	30073200402100
Closed	30073000401800
Closed	30072900303200
Closed	27053500101900
Closed	32062800200600
Closed	00900900000100
Closed	28060600201600
Closed	31053600400700
Closed	32051400302300
Closed	00473300001609



Accessory Dwelling Units

Index # - File Name: 1.0022 - Single Family Dwellings Data\_Snohomish County.pdf

Closed	0091500000100
Closed	0091500000200
Closed	30073200102000
Closed	28072100302500
Closed	29060300402100
Closed	00877800000800
Closed	00877800000900
Closed	27051600100600
Closed	31041000200600
Closed	00625300002300
Closed	28060500100600
Closed	27051600405700
Closed	28070800400200
Closed	27051000404600
Closed	27051000101200
Closed	27050300301800
Closed	27061800302400
Closed	27091500203000
Closed	27052100207600
Closed	27052400200900
Closed	27052800103400
Closed	27063000203100
Closed	00374100100105
Closed	00374100100106
Closed	00416300000700
Closed	00403900025000
Closed	00403800004102
Closed	00429500002200
Closed	00623700004900
Closed	00556600004100
Closed	00500100001000
Closed	28063200102600
Closed	28063300401200
Closed	28093100403500
Closed	28073300406000
Closed	00379900000100
Closed	00373800400601
Closed	00374800003000
Closed	28052900300500
Closed	28063000200200
Closed	28051600300500
Closed	28051100100500
Closed	28070700300300
Closed	28070700300700
Closed	28060200202400
Closed	28060200403100
Closed	00622200000400

Accessory Dwelling Units

Index # - File Name: 1.0022 - Single Family Dwellings Data\_Snohomish County.pdf

Closed	00632700000200
Closed	29060300300800
Closed	29060300200800
Closed	29061500102900
Closed	29062700200100
Closed	29062600302400
Closed	29062600300900
Closed	29062800402000
Closed	29072800201300
Closed	29063300100700
Closed	29052600103000
Closed	00396500000700
Closed	28060200303400
Closed	00614700601202
Closed	00614800002000
Closed	00579200001400
Closed	00570700100700
Closed	00573800000700
Closed	00574100011500
Closed	30052500400200
Closed	30040300201000
Closed	30060200400100
Closed	30050500201900
Closed	00492000103500
Closed	00457100005600
Closed	00457100002501
Closed	00597300000201
Closed	30050100202400
Closed	00600200001603
Closed	00511000001900
Closed	00489200000900
Closed	00429900002400
Closed	00429900002500
Closed	00470600006300
Closed	30063100400900
Closed	30063200302200
Closed	30052900203100
Closed	31060400301400
Closed	31040800202700
Closed	31040900101400
Closed	31062100201000
Closed	31051800202900
Closed	00394406700600
Closed	00394507000901
Closed	00381900002600
Closed	31063300102100
Closed	32042400102000

Accessory Dwelling Units

Index # - File Name: 1.0022 - Single Family Dwellings Data\_Snohomish County.pdf

Closed	32042600100800
Closed	32053100400300
Closed	32062900100100
Closed	32051300301700
Closed	32040500301600
Closed	32040500402500
Closed	32060300400600
Closed	32080200301100
Closed	00499100100100
Closed	00492400201200
Closed	00483000007000
Closed	28063200302700
Closed	30063400303100
Closed	28060300301400
Closed	00617300100902
Closed	00373300400708
Closed	00960007002600
Closed	29072200200200
Closed	27043500100800
Closed	27090900200300
Closed	00541700001102
Closed	30063200202300
Closed	27052100403400
Closed	29060300100700
Closed	00403900018408
Closed	00403900018409
Closed	00821200000400
Closed	27062800400300
Closed	30062800200100
Closed	32043600200700
Closed	32063500200400
Closed	32063500300600
Closed	32063300201300
Closed	32063300303000
Closed	32063200400300
Closed	31050100102400
Closed	00374800003100
Closed	28073200402000
Closed	32073000301700
Closed	32043600201600
Closed	00818500000900
Closed	00617300100504
Closed	28050100304200
Closed	27062800403200
Closed	30060200300200
Closed	00556600012800
Closed	31060600402500

Accessory Dwelling Units

Index # - File Name: 1.0022 - Single Family Dwellings Data\_Snohomish County.pdf

Closed	00483000004800
Closed	00492400200800
Closed	00585200006002
Closed	32041300201300
Closed	32052700302000
Closed	32052300202800
Closed	31062800102100
Closed	31042600402100
Closed	00394507700200
Closed	00394510901403
Closed	00394510200903
Closed	00394510200900
Closed	00394510200901
Closed	00394509901600
Closed	00482900004100
Closed	31062000300900
Closed	31062000400400
Closed	31062100101000
Closed	31060600102500
Closed	31040400401600
Closed	31050400101300
Closed	30062700201100
Closed	30053100100100
Closed	00401000006100
Closed	00451700002300
Closed	00451700002400
Closed	00582600102702
Closed	00590400000402
Closed	00579800000805
Closed	00627300010300
Closed	00557100301800
Closed	00777900000500
Closed	00611300018100
Closed	00611300019500
Closed	00625300000900
Closed	00597600000113
Closed	00441900001400
Closed	30040600101400
Closed	30070700300100
Closed	30060800100700
Closed	30061900100300
Closed	00574200005800
Closed	00574000010200
Closed	00574100005100
Closed	00574100002500
Closed	00597400000116
Closed	00604100000705

Accessory Dwelling Units

Index # - File Name: 1.0022 - Single Family Dwellings Data\_Snohomish County.pdf

Closed	00607000001400
Closed	00608100200300
Closed	00485200000900
Closed	00396500005500
Closed	00405600000300
Closed	00427400000400
Closed	29062400401400
Closed	29052300202600
Closed	29061600201000
Closed	29063500300500
Closed	29063500201100
Closed	29062900200900
Closed	29062600300700
Closed	29060400402100
Closed	00715600000100
Closed	28070900401500
Closed	28061600400600
Closed	28072600300900
Closed	28072600301200
Closed	28072800304200
Closed	28062400401100
Closed	00373800400102
Closed	00374900007001
Closed	28073300203200
Closed	00510300001800
Closed	00512000100200
Closed	00631900003100
Closed	00633400001000
Closed	00460200016900
Closed	00464100000200
Closed	00452600101002
Closed	00403800014402
Closed	00403900020905
Closed	00373101000202
Closed	00403800001201
Closed	00396300000302
Closed	27063000203100
Closed	27052400404100
Closed	27052500102700
Closed	00373002301601
Closed	00372800803701
Closed	00372601101202
Closed	27053300109500
Closed	27053300408100
Closed	27043500101300
Closed	27043500102700
Closed	27063500201500

Accessory Dwelling Units

Index # - File Name: 1.0022 - Single Family Dwellings Data\_Snohomish County.pdf

Closed	27071800102400
Closed	27051600402200
Closed	27070100301900
Closed	27050900404000
Closed	27051000401600
Closed	27051000202000
Closed	27051100300500
Closed	27051100200700
Closed	28070800201400
Closed	30060100203600
Closed	31052500302600
Closed	00394400203100
Closed	00868000000300
Closed	29073400300400
Closed	30062300101400
Closed	31041100200900
Closed	32063100102500
Closed	00926500000900
Closed	00960007014100
Closed	00490900000600
Closed	31042000202400
Closed	30072000203300
Closed	31062000401100
Closed	27071800100100
Closed	00494511400400
Closed	30072900303000
Closed	30073000401900
Closed	30073000402000
Closed	30073000402100
Closed	30073200401500
Closed	30073200402300
Closed	01043500003100
Closed	01043500000200
Closed	01043500000300
Closed	01043500000400
Closed	01043500000700
Closed	01043500002700
Closed	01043500002800
Closed	00394507101101
Closed	00375000005303
Closed	27051000200700
Closed	28083600305800
Closed	28061400401100
Closed	28061400400800
Closed	28073400301700
Closed	32053500300200
Closed	30060100204800

Accessory Dwelling Units

Index # - File Name: 1.0022 - Single Family Dwellings Data\_Snohomish County.pdf

Closed	00394403501600
Closed	28051100100100
Closed	00935300000200
Closed	00372801500400
Closed	00513700003401
Closed	31052400200100
Closed	32051500301100
Closed	29061700303200
Closed	29053500401600
Closed	01073800000500
Closed	01073800000500
Closed	01075700001100
Closed	01055500000600
Closed	01055500000700
Closed	28082100101700
Closed	01053400002900
Closed	01053400002400
Closed	01053400002500
Closed	01053400000800
Closed	29063000105400
Closed	29063000105500
Closed	31041500300300
Closed	28061100103400
Closed	01091300000100
Closed	01091300000200
Closed	01091300000300
Closed	01091300000400
Closed	01091300000500
Closed	01091300000600
Closed	01091300000700
Closed	01086100000200
Closed	27063300102600
Closed	00370500000403
Closed	01141000001200
Closed	01141000001300
Closed	30073000102400
Closed	00508900001903
Closed	00627600004100
Closed	01128000001100
Closed	01128000002400
Closed	01128000002900
Closed	01128000003000
Closed	01128000003100
Closed	01128000003200
Closed	01128000002200
Closed	01128000003500
Closed	01128000001500

Accessory Dwelling Units

Index # - File Name: 1.0022 - Single Family Dwellings Data\_Snohomish County.pdf

Closed	0112800001600
Closed	0112800001700
Closed	0112800001800
Closed	0112800001900
Closed	0112800002000
Closed	0112800000400
Closed	0112800000500
Closed	0112800000500
Issued	0112800000600
Closed	0112800000800
Closed	0112800004100
Closed	0112800004200
Closed	0112800003700
Closed	0112800004400
Closed	0112800004500
Closed	0112800004600
Closed	0112800004700
Closed	0112800004800
Closed	0112800004900
Closed	00380900201001
Closed	32052000402400
Closed	32052000402300
Closed	00373002400902
Closed	00373002400902
Closed	00373002400902
Closed	00373002400902
Closed	00373002400902
Closed	00373002400902
Closed	00373002400902
Closed	00373002400902
Closed	00394401903401
Closed	32042200103600
Closed	30060100204100
Closed	30060100205000
Closed	28052900306600
Closed	29062000211900
Closed	01142900004400
Closed	01142900004500
Closed	01142900004600
Closed	01142900004700
Closed	01142900004800
Closed	01142900004900
Closed	01146000003400
Closed	01146000003500
Closed	01142900004000
Closed	01142900004100
Closed	01142900005400



Accessory Dwelling Units

Index # - File Name: 1.0022 - Single Family Dwellings Data\_Snohomish County.pdf

Closed	01143600002800
Closed	01143600002900
Closed	01143600003000
Closed	01143600003100
Closed	01143600003200
Closed	01143600003300
Closed	01143600003400
Closed	01143600003500
Closed	01143600003600
Closed	01143600003700
Closed	01143600003800
Closed	01143600003900
Closed	01143600004000
Closed	01143600004100
Closed	01143600004200
Closed	00403800007801
Closed	01142900000400
Closed	01142900000500
Closed	01142900000600
Closed	01142900000700
Closed	01142900003500
Closed	01142900003600
Closed	01142900003700
Closed	01142900003800
Closed	01142900002600
Closed	01142900002700
Closed	01142900002800
Closed	01142900002900
Closed	01142900003000
Closed	01142900003100
Closed	01142900003200
Closed	01142900000900
Closed	01142900001000
Closed	01142900006800
Closed	01142900006900
Closed	01142900007000
Closed	01142900007100
Closed	01142900007200
Closed	01142900007300
Closed	01142900007400
Closed	01142900007500
Closed	01142900007600
Closed	01142900007700
Closed	00467100006300
Closed	01146100001000
Closed	01146100001100
Closed	01146100001200

Accessory Dwelling Units

Index # - File Name: 1.0022 - Single Family Dwellings Data\_Snohomish County.pdf

Closed	01146100001300
Closed	01146100001400
Closed	01146100001500
Closed	01146100001600
Closed	01146100001700
Closed	01146100001800
Closed	01146100001900
Closed	01143400000100
Closed	01143400000200
Closed	01143400000300
Closed	01143400000400
Closed	01143400000500
Closed	01143400000600
Closed	01143400000700
Closed	01143400000800
Closed	01143400000900
Closed	01143400001000
Closed	01143400001100
Closed	01143400001200
Closed	01143400001300
Closed	01143400001400
Closed	01143400001500
Closed	01143400001600
Closed	01143400001700
Closed	01143400001800
Closed	01143400001900
Closed	01143400002000
Closed	01143400002100
Closed	01143400002200
Closed	01143400002300
Closed	01143400002400
Closed	01143600000100
Closed	01143600000200
Closed	01143600000300
Closed	01143600000400
Closed	01143600000500
Closed	01142900005800
Closed	01142900005900
Closed	01142900006000
Closed	01142900006100
Closed	01142900006200
Closed	01142900006300
Closed	01142900006400
Closed	01142900005100
Closed	00585200006600
Closed	00585200006700
Closed	00585200006800

Accessory Dwelling Units

Index # - File Name: 1.0022 - Single Family Dwellings Data\_Snohomish County.pdf

Closed	00394403400100
Closed	28073200404000
Closed	00394403201500
Closed	29063500303300
Closed	29062500400200
Closed	00445400100111
Closed	00608100300202
Closed	00452600101004
Closed	00513100000310
Closed	01146200000900
Closed	01146200001000
Closed	01146200001100
Closed	28072600302700
Closed	00490400000600
Closed	01146200001400
Closed	01146200001700
Closed	01146200002100
Closed	00394405004001
Closed	01149500001600
Closed	01149500001700
Closed	01149500001800
Closed	01149500001900
Closed	01149500002000
Closed	01149500002100
Closed	01149500002900
Closed	01149500003000
Closed	29070800400500
Closed	01149100000300
Closed	01149100000800
Closed	01149100000900
Closed	01149100001000
Closed	01149100001100
Closed	01149100001200
Closed	01149100001300
Closed	01149100001400
Closed	01149100001500
Closed	01149100001600
Closed	01149100001700
Closed	01149100001800
Closed	01149100002100
Closed	01149100002200
Closed	01149100002300
Closed	01149100002400
Closed	01149100002500
Closed	01149100002600
Closed	01149100002700
Closed	01149100002800

Accessory Dwelling Units

Index # - File Name: 1.0022 - Single Family Dwellings Data\_Snohomish County.pdf

Closed	00532000004200
Closed	01146900000100
Closed	01146900000300
Closed	01146900000400
Closed	01146900000900
Closed	01146900001000
Closed	01146900001100
Closed	01146900001200
Closed	01146900001300
Closed	01146900001600
Closed	01146900001800
Closed	01146900001900
Closed	01146900002000
Closed	01146900002100
Closed	01146900002200
Closed	01146900002300
Closed	01146900002400
Closed	01150500000600
Closed	01150500000700
Closed	01150500000800
Closed	01150500000900
Closed	01150500001000
Closed	27052100308300
Closed	27052100308400
Closed	27052100308500
Closed	27052100308600
Closed	27052100308700
Closed	30063200100500
Closed	01145800000100
Closed	01145800000200
Closed	01145800000300
Closed	01146000002300
Closed	01146000000600
Closed	01146000000700
Closed	01146000000800
Closed	01146000000900
Closed	01146000001000
Closed	01146000001100
Closed	01146000001200
Closed	01146000001300
Closed	01146000001400
Closed	01146000001500
Closed	01146000001600
Closed	01146000001700
Closed	01146000001800
Closed	01146000001900
Closed	01146000002000

Accessory Dwelling Units

Index # - File Name: 1.0022 - Single Family Dwellings Data\_Snohomish County.pdf

Closed	0114580000800
Closed	0114580000900
Closed	0114580001000
Closed	0114580001100
Closed	0114580001200
Closed	0114580001300
Closed	0114580001400
Closed	0114580001500
Closed	0114580001600
Closed	0114580001700
Closed	0114580001800
Closed	0114580001900
Closed	0114580002000
Closed	0114580002100
Closed	0114580002200
Closed	0114580002300
Closed	0114580002500
Closed	0114580002700
Closed	0114580002800
Closed	0114580002900
Closed	0114580003000
Closed	0114580003100
Closed	0114580003200
Closed	0114580003300
Closed	0114580003500
Closed	00609600002000
Closed	01147800000100
Closed	01147800000700
Closed	01147800000800
Closed	01147800000900
Closed	01147800001000
Closed	01147800001100
Closed	01147800001200
Closed	01147800001300
Closed	01147800001400
Closed	01147800001500
Closed	01147800001600
Closed	01147800001700
Closed	01147800001800
Closed	01147800001900
Closed	01147800002000
Closed	01147800002100
Closed	01147800002200
Closed	01147800002300
Closed	01147800002400
Closed	01147800002500
Closed	01147800003000

Accessory Dwelling Units

Index # - File Name: 1.0022 - Single Family Dwellings Data\_Snohomish County.pdf

Closed	01144800000400
Closed	01144800000600
Closed	01144800001000
Closed	01144800001100
Closed	01144800001200
Closed	01144800001400
Closed	01144800001600
Closed	01144800001700
Closed	01144800001900
Closed	01144800002000
Closed	01144800002100
Closed	01144800002200
Closed	30061000102100
Closed	30061000102100
Closed	01146000000100
Closed	01146000000200
Closed	01146000000300
Closed	01146000000400
Closed	01144900000400
Closed	01151000002500
Closed	01151000002600
Closed	01146400000100
Closed	01146400000200
Closed	01146400000300
Closed	01146400000400
Closed	01146400000500
Closed	01146400000600
Closed	01146400000700
Closed	01146400000800
Closed	01146400000900
Closed	01146400001000
Closed	01146400001100
Closed	01146400001200
Closed	01146400001700
Closed	01146400001800
Closed	01146400001900
Closed	01146400002000
Closed	01146400002600
Closed	01146400002700
Closed	01146400002800
Closed	01146400002900
Closed	01146400003000
Closed	01146400003100
Closed	01146400003200
Closed	01146400003300
Closed	01146400003400
Closed	01146400003500

Accessory Dwelling Units

Index # - File Name: 1.0022 - Single Family Dwellings Data\_Snohomish County.pdf

Closed	01146400003600
Closed	01146400003700
Closed	01146400003800
Closed	01146400003900
Closed	01146400004000
Closed	01146400004100
Closed	01146400004200
Closed	01146400004300
Closed	01146400004400
Closed	32061000200500
Closed	00614700603600
Closed	27063400400600
Closed	01140800000600
Closed	30061900102400
Closed	01140800000200
Closed	00609600001900
Closed	01145700000200
Closed	01145700000300
Closed	01145700000400
Closed	01145700000500
Closed	01145700000600
Closed	01145700000700
Closed	01145700000800
Closed	01145700000900
Closed	01145700001000
Closed	01145700001100
Closed	01144900001000
Closed	01144900001100
Closed	01144900001200
Closed	01144900001300
Closed	01144900001400
Closed	01144900001500
Closed	01144900001600
Closed	01151000000200
Closed	00509300002508
Closed	00513100000908
Closed	32053500302200
Closed	01145900004400
Closed	01145100001000
Closed	01147000000400
Closed	01147000000800
Closed	01147000000900
Closed	01147000001000
Closed	01147000001200
Closed	01147000001500
Closed	01147000001600
Closed	01147000001700

Accessory Dwelling Units

Index # - File Name: 1.0022 - Single Family Dwellings Data\_Snohomish County.pdf

Closed	0114700001800
Closed	31052500101900
Closed	01145900003000
Closed	01145900003100
Closed	29071900301800
Closed	01142400001900
Closed	01142400002000
Closed	01142400002700
Closed	01142400002800
Closed	01142400002900
Closed	01142400003000
Closed	01142400003100
Closed	01142400003200
Closed	01142400003300
Closed	01142400003400
Closed	01142400005700
Closed	01142400005800
Closed	01142400005900
Closed	01142400006000
Closed	01142400006100
Closed	01142400006200
Closed	01142400006300
Closed	01142400006400
Closed	01142400006500
Closed	01142400006600
Closed	01142400006700
Closed	01142400006800
Closed	01145900000100
Closed	01145900000200
Closed	01145900000300
Closed	01145900000400
Closed	01145900000500
Closed	01145900000600
Closed	01145900001300
Closed	01145900002100
Closed	01145900002200
Closed	01145900002300
Closed	01145900002400
Closed	01145900002500
Closed	01145900004900
Closed	01145900005000
Closed	01145900005100
Closed	01145900005200
Closed	01145900005300
Closed	01145900005400
Closed	01145900005500
Closed	01145900005600



Accessory Dwelling Units

Index # - File Name: 1.0022 - Single Family Dwellings Data\_Snohomish County.pdf

Closed	01145900005700
Closed	01145900005800
Closed	01145900005900
Closed	01145900006000
Closed	01145900006100
Closed	01145900006200
Closed	01145900006300
Closed	01145900006400
Closed	01145900006500
Closed	01145900006600
Closed	01145900006700
Closed	01145900006800
Closed	01145900006900
Closed	01145900007000
Closed	01145900007100
Closed	01145900007200
Closed	01145900007300
Closed	01145900007400
Closed	01145900007500
Closed	01145900007600
Closed	01149100003400
Closed	01149100003500
Closed	01149100003600
Closed	01149100003700
Closed	01149100003800
Closed	01149100003900
Closed	01149100004000
Closed	01149100004100
Closed	01149100004200
Closed	01149100004300
Closed	01150500001500
Closed	01150500001600
Closed	01150500002700
Closed	01150500002800
Closed	01150500002900
Closed	01150500003000
Closed	01150500003100
Closed	01150500003200
Closed	01150500003300
Closed	01150500003400
Closed	01150500003500
Closed	01150500003600
Closed	01150500003700
Closed	01150500003800
Closed	01150500003900
Closed	01150500004000
Closed	01150500004100

Accessory Dwelling Units

Index # - File Name: 1.0022 - Single Family Dwellings Data\_Snohomish County.pdf

Closed	01150500004200
Closed	01150500004300
Closed	01150500004400
Closed	01150500004500
Closed	00597600000102
Closed	32042500300900
Closed	01149600000300
Closed	01149600000400
Closed	01149600000500
Closed	01149600000700
Closed	01149000000100
Closed	01149000000200
Closed	01149000000300
Closed	01149000000400
Closed	01149000000500
Closed	01149000000600
Closed	01149000000800
Closed	01149000000900
Closed	01149000001000
Closed	01149000001100
Closed	01149000001800
Closed	01149000001900
Closed	01149000002000
Closed	01149500004300
Closed	01149500004400
Closed	01149500004600
Closed	00372901101100
Closed	00372901101100
Closed	00372901101100
Closed	00372901101100
Closed	01149100003200
Closed	00591200200105
Closed	01149900001000
Closed	30062400103200
Closed	28073500201900
Closed	01149400004600
Closed	27070200202100
Closed	00373701001300
Closed	30062800200600
Closed	00394404100100
Closed	27050400404600
Closed	00389400300300
Closed	00561600001700
Closed	31060500200600
Closed	28063100202200
Closed	01150200000500
Closed	01150200000600

Accessory Dwelling Units

Index # - File Name: 1.0022 - Single Family Dwellings Data\_Snohomish County.pdf

Closed	01150200000900
Closed	01150200001100
Closed	01150200001200
Closed	00568900000201
Closed	00568900000202
Closed	00568900000203
Closed	00568900000205
Closed	00568900000206
Closed	00568900000207
Closed	01153400000600
Closed	01153400001900
Closed	01150200001600
Closed	32053500302100
Closed	27052100206000
Closed	27052100206000
Closed	27052100206000
Closed	27052100206000
Closed	27052100206000
Closed	01153100000100
Closed	01153100000900
Closed	01153100001500
Closed	01153100001600
Closed	00373002101402
Closed	00373002101402
Closed	00373002101402
Closed	00373002101402
Closed	00373002101402
Closed	00373002101402
Closed	00373002101402
Closed	00373002101402
Closed	00373002101402
Closed	00373002101402
Closed	00373002101402
Closed	00373002101402
Closed	00373002101402
Closed	00373002101402
Closed	00373002101402
Closed	29062500400600
Closed	29062500400900
Closed	29062500400100
Closed	30063100205400
Closed	00373003001106
Closed	00625900003901
Closed	01151100001000
Closed	01151100001100
Closed	01151100001200
Closed	01151100001300
Closed	00502700000200
Closed	00461000500104
Closed	00461000500104

Accessory Dwelling Units

Index # - File Name: 1.0022 - Single Family Dwellings Data\_Snohomish County.pdf

Closed	00461000500104
Closed	01152500001600
Closed	01152500002600
Closed	01152500002700
Closed	00516700004400
Closed	28073000102700
Closed	00555300400503
Closed	27050900304500
Closed	00509200201100
Closed	28081800302500
Closed	30050100402900
Closed	29063500102500
Closed	01132400013700
Closed	01132400013800
Closed	01132400013900
Closed	01132400014000
Closed	01132400014100
Closed	01132400014200
Closed	01132400014300
Closed	01132400014800
Closed	31052500101000
Closed	31052500101300
Closed	01137400000800
Closed	01137400000900
Closed	01137400000200
Closed	01137400000300
Closed	01137400000600
Closed	32053500302300
Closed	00374100200106
Closed	01134300000100
Closed	01134300000200
Closed	01134300000300
Closed	01134300000400
Closed	01134300000500
Closed	01134300000600
Closed	01134300000700
Closed	01134300000800
Closed	01134300001000
Closed	01134300001100
Closed	01134300001200
Closed	01134300001300
Closed	01134300001400
Closed	01134300005500
Closed	01134300005600
Closed	01134300005700
Closed	01134300005800
Closed	01134300005900

Accessory Dwelling Units

Index # - File Name: 1.0022 - Single Family Dwellings Data\_Snohomish County.pdf

Closed	01134300006000
Closed	01134300006100
Closed	01134300006200
Closed	01134300006300
Closed	01134300006400
Closed	01134300006500
Closed	01134300006600
Closed	01134300006700
Closed	01134300006800
Closed	31043100402400
Closed	31043100402500
Closed	31043100402700
Closed	31043100402600
Closed	00568700500810
Closed	01134300003800
Closed	01134300003200
Closed	00457100002104
Closed	01131600001300
Closed	01131600003500
Closed	01131600004000
Closed	01131600002200
Closed	01131600002300
Closed	01131600002400
Closed	01131600002500
Closed	01131600002600
Closed	01131600002700
Closed	01131600002800
Closed	01131600001900
Closed	01142400000100
Closed	01142400000200
Closed	01142400000300
Closed	01142400000400
Closed	01142400000500
Closed	01142400000600
Closed	01142400000700
Closed	01142400000800
Closed	01142400000900
Closed	01142400001000
Closed	01142400001100
Closed	01142400001200
Closed	01142400001300
Closed	01142400001400
Closed	01142400001500
Closed	01142400001600
Closed	01142400001700
Closed	01139200003200
Closed	01139200003300

Accessory Dwelling Units

Index # - File Name: 1.0022 - Single Family Dwellings Data\_Snohomish County.pdf

Closed	01139200003400
Closed	01139200000200
Closed	01139200000300
Closed	01139200000400
Closed	00394404102700
Closed	01143000000100
Closed	01143000000200
Closed	01143000000300
Closed	01143000000400
Closed	01143000000500
Closed	01143000000600
Closed	01143000000700
Closed	01143000000800
Closed	01143000000900
Closed	01143000001000
Closed	01143000001100
Closed	29061400100900
Closed	27052800211000
Closed	01139200002200
Closed	01139200002200
Closed	01139200002300
Closed	01139200002400
Closed	01139200002500
Closed	01139200002600
Closed	01139200002700
Closed	01139200002800
Closed	01139200002900
Closed	01139200001500
Closed	01140300002500
Closed	01140300002600
Closed	01140300002700
Closed	01142800002400
Closed	01142800002800
Closed	01142800000100
Closed	01142800000200
Closed	01142800000300
Closed	01142800001000
Closed	01142800001100
Closed	01142800001400
Closed	01142800001500
Closed	01142800001600
Closed	01142800001700
Closed	01142800001800
Closed	01142800001900
Closed	01142800002000
Closed	01140300002000
Closed	01140300002100

Accessory Dwelling Units

Index # - File Name: 1.0022 - Single Family Dwellings Data\_Snohomish County.pdf

Closed	01140300002200
Closed	01140300000500
Closed	01139800000900
Closed	00372800203402
Closed	00394404102500
Closed	00373002301400
Closed	01139500002300
Closed	01139500002400
Closed	01139500001700
Closed	01139500000900
Closed	01139500001000
Closed	01144000002400
Closed	01144000002500
Closed	01144000002600
Closed	01144000002700
Closed	01144000003600
Closed	01144000003700
Closed	01144000003800
Closed	01144000003900
Closed	01144000004000
Closed	01144000004100
Closed	01144000004200
Closed	01144000004300
Closed	01144000004400
Closed	01144000004500
Closed	01144000004600
Closed	01144000005000
Closed	01144000005100
Closed	01144000005200
Closed	01144000005300
Closed	01144000005400
Closed	01144000005500
Closed	01144000005600
Closed	01144000005700
Closed	01144000005800
Closed	01144000005800
Closed	01144000005900
Closed	01144000006000
Closed	01144000006100
Closed	01144000006200
Closed	01144000006300
Closed	01144000006400
Closed	01144000006500
Closed	01144000006600
Closed	01144000006700
Closed	01138300000700
Closed	01138300000800

Accessory Dwelling Units

Index # - File Name: 1.0022 - Single Family Dwellings Data\_Snohomish County.pdf

Closed	01138300000900
Closed	01138300000500
Closed	01142300000600
Closed	01142300000700
Closed	01142300000800
Closed	01142300003300
Closed	01142300003400
Closed	01142300003500
Closed	01142300003700
Closed	01142300004000
Closed	01142300004700
Closed	01142300004800
Closed	29070800400300
Closed	01144000000300
Closed	01144000000400
Closed	01144000000500
Closed	01144000000600
Closed	01144000000700
Closed	01144000000800
Closed	01144000000900
Closed	01144000001000
Closed	01144000001100
Closed	01142300004200
Closed	01144000001500
Closed	01144000001600
Closed	01144000001800
Closed	01144000001900
Closed	01144000002000
Closed	01142300001500
Closed	01142300001600
Closed	01142300001700
Closed	01142300001800
Closed	01142300001900
Closed	01142300002000
Closed	01142300002100
Closed	01142300002200
Closed	01142300002300
Closed	01142300002400
Closed	01142300002500
Closed	01142300002600
Closed	01142300002700
Closed	01142300002800
Closed	01142300002900
Closed	01142300003000
Closed	01142300000200
Closed	01138400000200
Closed	01138300000100



Accessory Dwelling Units

Index # - File Name: 1.0022 - Single Family Dwellings Data\_Snohomish County.pdf

Closed	0113830000200
Closed	0113830000300
Closed	0113670000700
Closed	0113980000700
Closed	01139800007100
Closed	01139800002800
Closed	01139800002900
Closed	01134300004700
Closed	01134300004800
Closed	01134300004900
Closed	01134300004500
Closed	31050500102800
Closed	01138200002200
Closed	32052200304500
Closed	00394509101500
Closed	01135900001500
Closed	01135900000700
Closed	01135900000800
Closed	01135900000900
Closed	01135900001000
Closed	01135900001100
Closed	01135900003100
Closed	01140100000100
Closed	32051800200600
Closed	31061800203900
Closed	31061800204400
Closed	01135900002100
Closed	01140100004000
Closed	01140100004100
Closed	01140100001700
Closed	01140100001800
Closed	01140100001900
Closed	01140100002000
Closed	01140100002100
Closed	01140100002200
Closed	01140100002300
Closed	01140100002400
Closed	01140100001100
Closed	01140100001200
Closed	01140100001300
Closed	01140100001400
Closed	01140100001500
Closed	01139800006600
Closed	01139800006700
Closed	01139800006800
Closed	01138600002000
Closed	01138600002100

Accessory Dwelling Units

Index # - File Name: 1.0022 - Single Family Dwellings Data\_Snohomish County.pdf

Closed	01139800001100
Closed	01139800001200
Closed	01143500001200
Closed	01139800001700
Closed	01139800001800
Closed	01143500000700
Closed	31052000202700
Closed	27051800401300
Closed	27051800401300
Closed	32042200104200
Closed	30040800401000
Closed	01116800001500
Closed	01116800001100
Closed	01116800000300
Closed	01116800000400
Closed	01116800000500
Closed	01116800000600
Closed	01116800000700
Closed	01116800000100
Closed	32091300100300
Closed	01125600001000
Closed	01128600000500
Closed	01128600000200
Closed	32051900401300
Closed	01128600000400
Closed	00493900006700
Closed	00493900006700
Closed	00493900006700
Closed	01150700000300
Closed	01150700000400
Closed	01150700000500
Closed	01150700000600
Closed	01150700000700
Closed	01150700000800
Closed	01125900002200
Closed	00614700601600
Closed	29061500303200
Closed	01131600001200
Closed	28060200305000
Closed	01116800000200
Closed	31042300101000
Closed	01116800000800
Issued	01116800000900
Closed	01116800001200
Closed	01116800001300
Closed	01116800001400
Closed	00394401803600

Accessory Dwelling Units

Index # - File Name: 1.0022 - Single Family Dwellings Data\_Snohomish County.pdf

Closed	00394401804000
Closed	01109500001600
Closed	30062900400300
Closed	30062900400300
Closed	01114100002200
Closed	01114100002300
Closed	01114100002400
Closed	01109500002400
Closed	01114100000400
Closed	01114100000500
Closed	01114100000600
Closed	01114100000700
Closed	01114100000800
Closed	32042200104100
Closed	27051700203200
Closed	01139800001300
Closed	01139800001400
Closed	01139800001500
Closed	01139800001600
Closed	01143500000100
Closed	01139800000100
Closed	01139800000200
Closed	01139800000300
Closed	28062200100900
Closed	01139800007200
Closed	01139800007300
Closed	01139800007400
Closed	01139800007500
Closed	01139800007600
Closed	01139800007700
Closed	01139800007800
Closed	01139800007900
Closed	01139800008000
Closed	01139800008100
Closed	01138300000400
Closed	01142300000500
Closed	01142300003100
Closed	01142300003200
Closed	01144000002100
Closed	01144000002200
Closed	01144000002300
Closed	01144000001700
Closed	01142300004300
Closed	01144000001200
Closed	01144000001300
Closed	01144000001400
Closed	01142300004100

Accessory Dwelling Units

Index # - File Name: 1.0022 - Single Family Dwellings Data\_Snohomish County.pdf

Closed	01142300003800
Closed	01142300003900
Closed	01142300003600
Closed	01138300000600
Closed	01144000003100
Closed	01144000003200
Closed	01144000003300
Closed	01144000003400
Closed	01144000003500
Closed	01142800002100
Closed	01142800002200
Closed	01142800002300
Closed	01142800000400
Closed	01142800000500
Closed	01142800000600
Closed	01142800000700
Closed	01142800000800
Closed	01142800000900
Closed	01142800002900
Closed	01142800002700
Closed	00614800001100
Closed	01131600001500
Closed	01131600003300
Closed	01131600003000
Closed	01131600003100
Closed	28072900200900
Closed	27061900201700
Closed	01137400000500
Closed	00394403702200
Closed	30050100403100
Closed	00509200201100
Closed	00509200201100
Closed	00509200201100
Closed	29053500402300
Closed	27050900304500
Closed	27050900304500
Closed	27050900304500
Closed	27050900304500
Closed	27050900304500
Closed	27050900304500
Issued	01153500002700
Closed	01153500002800
Closed	01153500004200
Closed	01153500004300
Closed	32053500302000
Closed	27050900106100
Closed	01153500000500



Accessory Dwelling Units

Index # - File Name: 1.0022 - Single Family Dwellings Data\_Snohomish County.pdf

Closed	00372700801101
Closed	00372700801101
Closed	00372700801101
Closed	00569000004200
Closed	00569000004200
Closed	00569000004200
Closed	00569000004200
Closed	00569000004200
Closed	00953000050100
Closed	00953000050100
Closed	00953000050100
Closed	00953000050100
Closed	00953000050100
Closed	00953000050100
Closed	00953000050100
Closed	00953000050100
Closed	00953000050100
Closed	00953000050100
Closed	00953000050100
Closed	00953000050100
Closed	00953000050100
Closed	00953000050100
Closed	00953000050100
Closed	00953000050100
Closed	00953000050100
Closed	00953000050100
Closed	00953000050100
Closed	00953000050100
Closed	00953000050100
Closed	00953000050100
Closed	00953000050100
Closed	00953000050100
Closed	00953000050100
Closed	00953000050100
Closed	00953000050100
Closed	00953000050100
Closed	00953000050100
Closed	01156300000100
Closed	01156300000200
Closed	01156300000300
Closed	01156300000400
Closed	01156300000500
Closed	01156300000600
Closed	01156300000700
Closed	01156300000800
Closed	01156300000900
Closed	01156300001000

Accessory Dwelling Units

Index # - File Name: 1.0022 - Single Family Dwellings Data\_Snohomish County.pdf

Closed	01156300001100
Closed	01156300001200
Closed	01156300001300
Closed	01156300001400
Closed	01156300001500
Closed	01156300001600
Closed	01156300002400
Closed	31063100101800
Closed	01153600002600
Closed	01153600002700
Closed	27070300202100
Closed	01153600000100
Closed	01153600000200
Closed	01153600000300
Closed	01153600000400
Issued	01153600001800
Closed	01153600001900
Closed	01153600002200
Closed	01153600002300
Closed	01154100000200
Closed	01154100000100
Closed	01154100000300
Closed	01154100000400
Closed	01154100000500
Closed	01154100000600
Closed	01154100000700
Closed	01154100000800
Closed	01154100000900
Closed	01154100001000
Closed	01154100001100
Closed	01154300000100
Closed	01154300000200
Closed	01154300000300
Closed	01154300000400
Closed	01154300000500
Closed	01154300000600
Closed	01154300000700
Closed	01154300000800
Closed	01154300000900
Closed	01154300001000
Closed	01154300001100
Closed	01154300001200
Closed	01154300001300
Closed	01154300001400
Closed	01154300001500
Closed	01154300001600
Closed	01154300001700

Accessory Dwelling Units

Index # - File Name: 1.0022 - Single Family Dwellings Data\_Snohomish County.pdf

Closed	01154300001800
Closed	01154300001900
Closed	01154300002000
Closed	01154300002100
Closed	01154300002200
Closed	01154300002300
Closed	01152500001700
Closed	01152500001800
Closed	01152500001900
Closed	01152500002000
Closed	01152500002100
Closed	01152500002200
Closed	01152500002300
Closed	01152500002400
Closed	01152500002500
Closed	01152500000100
Closed	01152500000200
Closed	01152500000300
Closed	01152500000400
Closed	01152500000500
Closed	01152500000600
Closed	01152500000700
Closed	01152500000800
Closed	01152500000900
Closed	01152500001000
Closed	01152500001100
Closed	01152500001200
Closed	01152500001300
Closed	01152500001400
Closed	01152500001500
Closed	27062000402900
Closed	27062000402900
Closed	01154200000100
Closed	01154200000200
Closed	01154200000300
Closed	01154200000400
Closed	01154200000500
Closed	01154200000600
Closed	01154200000700
Closed	01154200000800
Closed	01154200000900
Closed	01154200001000
Closed	01154200001500
Closed	01154200001600
Closed	01154200001700
Closed	32040800100600
Closed	00461000500104



Accessory Dwelling Units

Index # - File Name: 1.0022 - Single Family Dwellings Data\_Snohomish County.pdf

Closed	0115670000300
Closed	0115670000400
Closed	01156700001000
Closed	01156700001100
Closed	01156700001400
Closed	32051900402300
Closed	01151100001300
Closed	00511300003101
Closed	00373002101402
Closed	00373002101402
Closed	00373002101402
Closed	00373002101402
Closed	00373002101402
Closed	00373002101402
Closed	00373002101402
Closed	00373002101402
Closed	00373002101402
Closed	00373002101402
Closed	01153100000200
Closed	01153100000300
Closed	01153100000400
Closed	01153100000500
Closed	01153100000600
Closed	01153100000700
Closed	31062000103600
Closed	01149500003900
Closed	01154600000500
Closed	01154600000600
Closed	01154600000800
Closed	01154600000900
Closed	01154600001000
Closed	01153400000800
Closed	01153400000900
Closed	01153400001000
Closed	01153400001100
Closed	01153400001200
Closed	01153400001300
Closed	01153400001400
Closed	01153400001500
Closed	01153400000400
Closed	01153400000500
Closed	01150200001300
Closed	01150200001400
Closed	01150200001500
Closed	01150200001000
Closed	01150200000800
Closed	01150200000100
Closed	01150200000200

Accessory Dwelling Units

Index # - File Name: 1.0022 - Single Family Dwellings Data\_Snohomish County.pdf

Closed	00372901000901
Closed	00372901000901
Closed	00372901000901
Closed	31063300202200
Closed	31063300202100
Closed	01155700000400
Closed	01155700001300
Closed	01155700001400
Closed	01155700001500
Closed	01155700001600
Closed	01155700001700
Closed	01155700001800
Closed	01155700002100
Closed	01155700002200
Closed	01151900000500
Closed	01151900000600
Closed	01151900000700
Closed	01151900000800
Closed	01151900000800
Closed	01151900000900
Closed	01151900001000
Closed	01149400004700
Closed	01149400004800
Closed	01149400004900
Closed	01149400005000
Closed	01149400005100
Closed	01149400005200
Closed	01149400005300
Closed	01149400005400
Closed	01149400005500
Closed	01149400005600
Closed	31052500103900
Closed	00373001500203
Closed	01149600000200
Closed	01160200001100
Closed	01160200000700
Closed	01160200000800
Closed	01149900000900
Closed	01149100003300
Closed	01149500004700
Closed	00532000002500
Closed	01149500004500
Closed	01149400001600
Closed	01149400001700
Closed	01149400001800
Closed	01149400002000
Closed	01149400002100

Accessory Dwelling Units

Index # - File Name: 1.0022 - Single Family Dwellings Data\_Snohomish County.pdf

Closed	01149400002200
Closed	01149400002300
Closed	01149400002400
Closed	01149400002500
Closed	01149400002600
Closed	01149400002700
Closed	01149400002800
Closed	01149400002900
Closed	01149400003000
Closed	01149400003100
Closed	01149400003300
Closed	01149400003400
Closed	01149400003500
Closed	01149400003600
Closed	01149400003700
Closed	01149400003800
Closed	01149400004000
Closed	01149400004100
Closed	01149400004200
Closed	01149400004300
Closed	01149400004400
Closed	01149400004500
Closed	01149000002200
Closed	01149000002300
Closed	01149000002400
Closed	01149000002500
Closed	01149000002600
Closed	01149000002700
Closed	01149000002800
Closed	01149000002900
Closed	01149000003000
Closed	01149000003100
Closed	01149000003200
Closed	01149000003300
Closed	00394405200700
Closed	01149400000100
Closed	01149400000200
Closed	01149400000300
Closed	01149400000400
Closed	01149400000500
Closed	01149400000600
Closed	01149400000700
Closed	01149400000800
Closed	01149400000900
Closed	01149400001000
Closed	01149400001100
Closed	00500100004100

Accessory Dwelling Units

Index # - File Name: 1.0022 - Single Family Dwellings Data\_Snohomish County.pdf

Closed	01150500001700
Closed	01150500001800
Closed	01150500001900
Closed	01150500002000
Closed	01150500002100
Closed	01150500002200
Closed	01150500002300
Closed	01150500002400
Closed	01150500002500
Closed	01150500002600
Closed	01149100004400
Closed	01145900002600
Closed	01145900002700
Closed	01145900002800
Closed	01145900002900
Closed	01145900000700
Closed	01145900000800
Closed	01145900000900
Closed	01145900001200
Closed	01145900003200
Closed	01145900003300
Closed	01145900003400
Closed	01145900003500
Closed	01145900003600
Closed	01145900003700
Closed	01145900003800
Closed	01145900003900
Closed	01145900004000
Closed	01145900004100
Closed	01145900004200
Closed	01145900004300
Closed	01145900004500
Closed	01145900004600
Closed	01145900004700
Closed	01145900004800
Closed	00419500000800
Closed	01140800000100
Closed	01151000000300
Closed	01151000000600
Closed	01151000000700
Closed	01151000001000
Closed	01151000001100
Closed	01151000001200
Closed	01151000001300
Closed	01151000001400
Closed	01151000001500
Closed	01151000001600

Accessory Dwelling Units

Index # - File Name: 1.0022 - Single Family Dwellings Data\_Snohomish County.pdf

Closed	01151000001700
Closed	01151000001800
Closed	01151000001900
Closed	01151000002000
Closed	01151000002100
Closed	01151000002200
Closed	01151000002300
Closed	01151000002400
Closed	01140800000300
Closed	01151000002700
Closed	01151000002800
Closed	01151000002900
Closed	01151000003000
Closed	01151000003100
Closed	01151000003600
Closed	01144900000500
Closed	01144900000600
Closed	01144900000700
Closed	01144900000800
Closed	00611300021900
Closed	01146000000500
Closed	00509300003500
Closed	01152000000300
Closed	01152000000800
Closed	01146000002100
Closed	01146000002400
Closed	01146000002500
Closed	01146000002600
Closed	01146000002700
Closed	01146000002800
Closed	01146000002900
Closed	01146000003000
Closed	01146000003100
Closed	01146000003200
Closed	01146000003300
Closed	01150500001100
Closed	01150500001200
Closed	01150500001300
Closed	01150500001400
Closed	01149100002900
Closed	01149500003100
Closed	01149500003200
Closed	01149500003300
Closed	01149500003400
Closed	01149500003500
Closed	01149500003600
Closed	01149500003700

Accessory Dwelling Units

Index # - File Name: 1.0022 - Single Family Dwellings Data\_Snohomish County.pdf

Closed	01149500003800
Closed	01149500004000
Closed	01149500004100
Closed	01149500002300
Closed	01149500002600
Closed	01149500002700
Closed	01149500002800
Closed	01149500000100
Closed	01149500000200
Closed	01149500000300
Closed	01149500000400
Closed	01149500000500
Closed	01149500000600
Closed	01149500000700
Closed	01149500000800
Closed	01149500000900
Closed	01149500001000
Closed	01149500001100
Closed	01149500001200
Closed	01149500001300
Closed	01149500001400
Closed	01149500001500
Closed	00560000003600
Closed	01153700001100
Closed	01153700001200
Closed	01153700001400
Closed	01146200001800
Closed	01146200001900
Closed	01146200002000
Closed	01146200001500
Closed	01146200001600
Closed	01146200001200
Closed	01146200001300
Closed	01146200000100
Closed	01146200000200
Closed	01146200000300
Closed	01146200000400
Closed	01146200000500
Closed	01146200000600
Closed	01146200000700
Closed	01146200000800
Closed	32071700300200
Closed	01142900005200
Closed	01142900005300
Closed	01152200000300
Closed	01142900006500
Closed	01142900006600

Accessory Dwelling Units

Index # - File Name: 1.0022 - Single Family Dwellings Data\_Snohomish County.pdf

Closed	01142900006700
Closed	01152200000500
Closed	01152200000600
Closed	01152200000700
Closed	01152200000800
Closed	01152200000900
Closed	01152200001000
Closed	01152200001100
Closed	01152200001200
Closed	01152200001400
Closed	01152200001600
Closed	01152200001700
Closed	01152200001800
Closed	01152200002000
Closed	01152200002300
Closed	01152200002400
Closed	01152200002500
Closed	01152200002600
Closed	01152200002700
Closed	01152200002800
Closed	01152200002900
Closed	01143600000600
Closed	01143600000700
Closed	01143600000800
Closed	01143600000900
Closed	01143600001000
Closed	01143600001100
Closed	01143600001200
Closed	01143600001300
Closed	01143600001400
Closed	01143600001500
Closed	01143600001600
Closed	01143600001700
Closed	01143600001800
Closed	01143600001900
Closed	01143600002000
Closed	01143600002100
Closed	01143600002200
Closed	01143600002300
Closed	01143600002400
Closed	01143600002500
Closed	01143600002600
Closed	01143600002700
Closed	01142900001100
Closed	01142900001200
Closed	01142900001300
Closed	01142900001400

Accessory Dwelling Units

Index # - File Name: 1.0022 - Single Family Dwellings Data\_Snohomish County.pdf

Closed	01142900001500
Closed	01142900001600
Closed	01142900001700
Closed	01142900001800
Closed	01142900001900
Closed	01142900002000
Closed	01142900002100
Closed	01142900002200
Closed	01142900002300
Closed	01142900002400
Closed	01142900002500
Closed	01142900003300
Closed	01142900003400
Closed	01142900003900
Closed	01142900000800
Closed	01152200000100
Closed	01142900005500
Closed	01142900005600
Closed	01142900005700
Closed	01142900005000
Closed	01160500001100
Closed	01160500001200
Closed	01160500000600
Closed	00579200001601
Closed	01160500001400
Closed	28053600106200
Closed	27050400304100
Closed	27050400304200
Closed	27050400304300
Closed	27050400304400
Closed	27050400304600
Closed	27050400304700
Closed	27050400304800
Closed	27050400304900
Closed	00461000500106
Closed	00461000500106
Closed	00461000500106
Closed	00587400001100
Closed	01163200000600
Closed	01163200000700
Closed	01163200000800
Closed	01163200000900
Closed	01163200001100
Closed	01163200001200
Closed	01163200001300
Closed	01163200001400
Closed	01163200001500



Accessory Dwelling Units

Index # - File Name: 1.0022 - Single Family Dwellings Data\_Snohomish County.pdf

Closed	01163200001600
Closed	01163200001700
Closed	01161500000100
Closed	01161500000200
Closed	01161500000300
Closed	01161500000400
Closed	01161500000500
Closed	01161500000600
Closed	01161500000700
Closed	01163200002000
Closed	01163200002100
Closed	01160500000100
Closed	01160500000200
Closed	00568800200808
Closed	00375000000700
Closed	00380900200300
Closed	00380900200300
Closed	00380900200300
Closed	00380900200300
Closed	00380900200300
Closed	00380900200300
Closed	28052700101300
Closed	00372801500401
Closed	01158300000100
Closed	01158300000400
Closed	01158300000500
Closed	01158300000600
Closed	01158300000700
Closed	01158300000800
Closed	01158300000900
Closed	01158300001000
Closed	01158300001100
Closed	01158300001200
Closed	01158300001300
Closed	01158300001400
Closed	01158300001500
Closed	01158300001600
Closed	01158300001700
Closed	01158300002200
Closed	01158300002300
Closed	01158300002400
Closed	01158300002500
Closed	01158300002600
Closed	01158300002700
Closed	01158300002800
Closed	01158300002900
Closed	01158300003000
Closed	01158300003100



Accessory Dwelling Units

Index # - File Name: 1.0022 - Single Family Dwellings Data\_Snohomish County.pdf

Closed	00537800002800
Closed	00537800002800
Closed	00537800002800
Closed	00537800002800
Closed	00537800002800
Closed	00537800002800
Closed	00537800002800
Closed	00537800002800
Closed	00537800002800
Closed	00537800002800
Closed	00537800002800
Closed	00537800002800
Closed	01159400000100
Closed	01159400000200
Closed	01159400000300
Closed	01159400000400
Closed	01159400000500
Closed	01159400000600
Closed	01159400000700
Closed	01159400000800
Closed	01159400000900
Closed	01159400001000
Closed	01159400001100
Closed	01159400001200
Closed	01159400001300
Closed	01159400001400
Closed	01159400001500
Closed	01159400002500
Closed	01159400002600
Closed	01159400002700
Closed	01159400002800
Closed	01159400002900
Closed	01159400003000
Closed	01159400003100
Closed	01159400003200
Closed	01159400003300
Closed	01159400003400
Closed	01159400003500
Closed	01159400003600
Closed	01159400003700
Closed	01159400003800
Closed	01159400003900
Closed	01159400004000
Closed	01159400004100
Closed	01157500000800
Closed	01157500000900
Closed	01157500001000

Accessory Dwelling Units

Index # - File Name: 1.0022 - Single Family Dwellings Data\_Snohomish County.pdf

Closed	01157500001100
Closed	01157500001200
Closed	01157500001300
Closed	29053600102200
Closed	00585200000100
Closed	28061600203600
Closed	28061000203700
Closed	28061000203800
Closed	00585200000100
Closed	01159700004000
Closed	01159700004100
Closed	01159700004200
Closed	01159700004300
Issued	01159700004400
Closed	01159700004500
Closed	01159700004600
Closed	01159700004700
Closed	01159700004800
Closed	01159700004900
Closed	01159700005000
Closed	01159700005100
Closed	01159700005200
Closed	01159700005300
Closed	01159700005400
Closed	01159700005500
Issued	01159700005600
Closed	01159700005700
Issued	01159700005800
Closed	01159700005900
Closed	01159700006000
Closed	01159700006100
Closed	01159700006200
Closed	01159700006300
Closed	01159700006400
Closed	01159700006500
Closed	01159700006600
Closed	01159700006700
Closed	01159700006800
Closed	01159700006900
Closed	01159700007000
Closed	01159700007100
Closed	01159700007200
Closed	01159700007300
Closed	01159700007400
Issued	01159700007500
Closed	01159700007600
Closed	01159700007700

Accessory Dwelling Units

Index # - File Name: 1.0022 - Single Family Dwellings Data\_Snohomish County.pdf

Closed	01159700007800
Closed	01159700002600
Closed	01159700002700
Issued	01159700002800
Closed	01159700002900
Closed	01159700003000
Closed	01159700003100
Closed	01159700003200
Closed	01159700003300
Closed	01159700003400
Closed	01159700003500
Closed	01159700003600
Closed	01159700003700
Closed	01159700003800
Closed	01159700003900
Closed	27051700203700
Closed	01159700001800
Closed	29061500304300
Closed	00490400000900
Closed	30040300202000
Closed	00394401500001
Closed	00394401500002
Closed	00608100400409
Closed	01156200001700
Closed	01156200001800
Closed	01156200002200
Closed	01159600000600
Closed	01159600000700
Closed	01159600000800
Closed	01160400000100
Closed	01160400000200
Closed	01160400000300
Closed	01160400000400
Closed	01156200002800
Closed	01159600000100
Closed	01159600000200
Closed	01159600000300
Closed	01160400000600
Closed	01160400000700
Closed	01160400000800
Closed	01160400000900
Closed	01160400001100
Closed	01160400001200
Closed	01160400001300
Closed	01160400001400
Closed	01160400001500
Closed	01160400001600

Accessory Dwelling Units

Index # - File Name: 1.0022 - Single Family Dwellings Data\_Snohomish County.pdf

Closed	01160400001700
Closed	01160400001800
Closed	01160400001900
Closed	01160400002000
Closed	01160400003000
Closed	01160400003100
Closed	01160400003200
Closed	01160400003300
Closed	01160400003400
Closed	01160400003500
Closed	01160400003600
Closed	01160400003700
Closed	01160400003800
Closed	01160400003900
Closed	01160400004000
Closed	01160400004100
Closed	01160400004200
Closed	29063600102500
Closed	00532100002700
Closed	00532100002700
Closed	00532100002700
Closed	00532100002700
Closed	00372900700502
Closed	28052800401500
Closed	28052800401500
Closed	28052800401500
Closed	28052800401500
Closed	28052800401500
Closed	28052800401500
Closed	28052800401500
Closed	28052800401500
Closed	28052800401500
Closed	28052800401500
Closed	28052800401500
Issued	28052800401500
Closed	28052800401500
Closed	28052800401500
Closed	28052800401500
Closed	28052800401500
Closed	28052800401500
Closed	28052800401500
Closed	28052800401500
Closed	28052800401500
Closed	28052800401500
Closed	28052800401500
Closed	28052800401500
Closed	28052800401500
Closed	01162400001000
Closed	01162400001100

Accessory Dwelling Units

Index # - File Name: 1.0022 - Single Family Dwellings Data\_Snohomish County.pdf

Closed	01162400001200
Closed	01160700000500
Closed	01160700000700
Closed	01160700000800
Closed	01160700001200
Closed	01160700001300
Closed	01160700001500
Closed	01160700001600
Closed	01160700001700
Closed	01160700001800
Closed	01160700001900
Closed	01160700002000
Closed	01160700002100
Closed	01160700002200
Closed	01160700002300
Closed	01160700002400
Closed	01160700002500
Closed	01160700002600
Closed	01160700002700
Closed	01160700002800
Closed	01160700002900
Closed	01160700003000
Closed	01160700003100
Closed	01160700003200
Closed	01160700003300
Closed	01160700003400
Closed	01160700003500
Closed	00372801203002
Closed	00372801203002
Closed	00372801203002
Closed	28053600106500
Closed	00585200000100
Closed	00585200000100
Closed	00585200000100
Closed	00585200000100
Closed	00568700401303
Closed	00568700401303
Closed	00568700401303
Closed	31063000300100
Closed	31061800400600
Closed	28053600106300
Closed	28053600106400
Closed	01162400000600
Closed	01162400000800
Closed	00403800002103
Closed	28051100203200
Closed	01158600001000

Accessory Dwelling Units

Index # - File Name: 1.0022 - Single Family Dwellings Data\_Snohomish County.pdf

Closed	01158600001100
Closed	00585200000100
Closed	00585200000600
Closed	00585200000100
Closed	00585200000100
Closed	00373002205904
Closed	27071800402800
Closed	30040200202100
Closed	30040200200900
Closed	30040200202300
Closed	30040200202400
Closed	30040200201100
Closed	27051600304300
Closed	27051600304300
Closed	27051600304300
Closed	27051600304300
Closed	27051600304300
Closed	27051600304300
Closed	27051600304300
Closed	27051600304300
Closed	27051600304300
Closed	27051600304300
Closed	27051600304300
Closed	27051600304300
Closed	27051600304300
Closed	27051600304300
Closed	27051600304300
Closed	27051600304300
Closed	27051600304300
Closed	27051600304300
Closed	27051600304300
Closed	27051600304300
Closed	27051600304300
Closed	27051600304300
Closed	27051600304300
Closed	27051600304300
Closed	27051600304300
Closed	27051600304300
Closed	27051600304300
Closed	27051600304300
Closed	27051600304300
Closed	27051600304300
Closed	27051600304300
Closed	27051600304300
Closed	27051600304300
Closed	27051600304300
Closed	27051600304300
Closed	27051600304300
Closed	27051600304300
Closed	27051600304300
Closed	27051600304300
Closed	27051600304300
Closed	00383800001500
Closed	00585200000100
Closed	00585200001000
Closed	27051600304300
Closed	27051600304300
Closed	27051600304300
Closed	00394401904500



Accessory Dwelling Units

Index # - File Name: 1.0022 - Single Family Dwellings Data\_Snohomish County.pdf

Closed	00585200000100
Closed	27080300401000
Closed	01145200000100
Closed	01145200000200
Closed	01145200000300
Closed	01145200000400
Closed	01145200000500
Closed	01145200000600
Closed	01145200000700
Closed	01145200000800
Closed	01145200000900
Closed	01145200001000
Closed	01145200001100
Closed	01145200001200
Closed	01145200001300
Closed	01145200001400
Closed	01098700001500
Closed	00373002400902
Closed	00373002400902
Closed	00373002400902
Closed	00373002400902
Closed	00373002400902
Closed	00373002400902
Closed	01109500001200
Closed	01109500001300
Closed	01128000003400
Closed	32071700200500
Closed	01128000002100
Closed	01128000003600
Closed	01128000002300
Closed	30073000200900
Closed	30073000102300
Closed	27050200100900
Closed	31032500401100
Closed	30042400100900
Closed	01083700000100
Closed	01083700000200
Closed	29073400401300
Closed	00394406300900
Closed	30063200303600
Closed	27063300402200
Closed	30051400201000
Closed	00533700000100
Closed	00533700000100
Closed	00533700000100
Closed	00533700000100
Closed	01053400000700

Accessory Dwelling Units

Index # - File Name: 1.0022 - Single Family Dwellings Data\_Snohomish County.pdf

Closed	01053400002600
Closed	01053400003000
Closed	28073600300600
Closed	31040800401500
Closed	30040200201300
Closed	30040200202200
Closed	00585200006500
Closed	31042000101500
Closed	30042400201100
Closed	28073200403900
Closed	28060300400300
Closed	01075700000900
Closed	01075700001000
Closed	01061500003300
Closed	01061500003400
Closed	01061500003000
Closed	01061500003100
Closed	29053500402500
Closed	29053500402100
Closed	27080600200100
Closed	01069300000600
Closed	01069300001000
Closed	00403800802300
Closed	00611300001000
Closed	29063200401400
Closed	00960010607700
Closed	29060400103600
Closed	32051900200300
Closed	00935400001100
Closed	00935400001400
Closed	00935400000900
Closed	32070800200400
Closed	28061600101200
Closed	00513700007221
Closed	28060300402000
Closed	01043500001800
Closed	30051200300300
Closed	27062900100800
Closed	29051100300700
Closed	27090400302900
Closed	00403900015700
Closed	28081900100900
Closed	29062100402000
Closed	27062500400500
Closed	00473300000702
Closed	00473300000802
Closed	31061800200300

Accessory Dwelling Units

Index # - File Name: 1.0022 - Single Family Dwellings Data\_Snohomish County.pdf

Closed	28061300300500
Closed	32061200401600
Closed	29062200401400
Closed	31060400102700
Closed	31062900400700
Closed	00960007015600
Closed	00960007012400
Closed	00960007010100
Closed	00960007010300
Closed	00960007001400
Closed	00960007002900
Closed	00960007004300
Closed	00960002501001
Closed	30073200102100
Closed	30073200101200
Closed	30072900302800
Closed	32053100402300
Closed	00960002414600
Closed	30061000402700
Closed	29061000103300
Closed	30062300102100
Closed	00608100400410
Closed	00403900027508
Closed	00608100500301
Closed	29053600100300
Closed	28051600200900
Closed	27051100101300
Closed	27051100400700
Closed	27100200200800
Closed	27060700401300
Closed	27090500401200
Closed	27090400400100
Closed	27090400101000
Closed	27051500400700
Closed	27091500201000
Closed	27071800201100
Closed	27061900101300
Closed	27062000401800
Closed	27063500202900
Closed	27063500203100
Closed	27053300404600
Closed	27063200400900
Closed	00372801601002
Closed	27063000201000
Closed	27062900401800
Closed	27062900402600
Closed	00403800000811

Accessory Dwelling Units

Index # - File Name: 1.0022 - Single Family Dwellings Data\_Snohomish County.pdf

Closed	00373002501203
Closed	00373700402500
Closed	00403800002102
Closed	00452600100900
Closed	00460200022100
Closed	00460200022200
Closed	00460200015500
Closed	00460200015600
Closed	00460200018200
Closed	00430400000300
Closed	00427100002000
Closed	00630500005000
Closed	00631900001300
Closed	00629900000600
Closed	00623700003400
Closed	00623700002500
Closed	00623700004300
Closed	00576700000601
Closed	00512000204700
Renewed	00509000003902
Renewed	00508900001706
Closed	00509000001803
Closed	00491400100309
Closed	28063200101400
Closed	28072500401200
Closed	28072500401300
Closed	28062300301200
Closed	28073000200600
Closed	28072900402900
Closed	28072900403600
Closed	28061400303600
Closed	28051700403300
Closed	28070700400700
Closed	28061400102000
Closed	00757700000200
Closed	00684000001500
Closed	00703000002800
Closed	28060400300900
Closed	29061400101100
Closed	29061000200500
Closed	00623600003600
Closed	00623800001100
Closed	00701500000300
Closed	29062700301400
Closed	29062800403300
Closed	29053600400900
Closed	29061700303100

Accessory Dwelling Units

Index # - File Name: 1.0022 - Single Family Dwellings Data\_Snohomish County.pdf

Closed	00511300003000
Closed	00511300003102
Closed	00511300003200
Closed	00570500200300
Closed	00570500200300
Closed	00568700401202
Closed	00614800001400
Closed	00574000007000
Closed	30061900101300
Closed	30042300400100
Closed	30041300300500
Closed	30061400103000
Closed	30061400103100
Closed	30061400102800
Closed	30061400102900
Closed	30040300100300
Closed	00440100002002
Closed	00491900203100
Closed	00492000109000
Closed	00581700001202
Closed	00581700001002
Closed	00626500001100
Closed	30050100402600
Closed	30050100400800
Closed	00631600002100
Closed	00631600007600
Closed	00736500001400
Closed	00622400000400
Closed	00579700000101
Closed	00495900003700
Closed	00511000009300
Closed	00543300001000
Closed	00543300009801
Closed	00401000002700
Closed	00422500004300
Closed	30063200303100
Closed	30063400303000
Closed	31060400401700
Closed	31060900300600
Closed	31042200200900
Closed	31042200402800
Closed	31051900202100
Closed	00480700002602
Closed	00394510701500
Closed	00394510601100
Closed	00394403400601
Closed	32052700301400

Accessory Dwelling Units

Index # - File Name: 1.0022 - Single Family Dwellings Data\_Snohomish County.pdf

Closed	32042300401300
Closed	32062100301300
Closed	32042200300100
Closed	32042200400200
Closed	32052900401100
Closed	32043000300600
Closed	32063100303600
Closed	32091200302300
Closed	00621500004000
Closed	00494511802900
Closed	00494511900700
Closed	00489700304102
Closed	32070700400200
Closed	32050700200300
Closed	32092700200100
Closed	30060500101900
Closed	30063300403300
Closed	29063200101100
Closed	27062900400400
Closed	28063000100100
Closed	00609100004600
Closed	00803900000600
Closed	00611300001100
Closed	28061200203500
Closed	32071900100400
Closed	32052200303400
Closed	30061600301200
Closed	32051200200700
Closed	30040800100800
Closed	00639500000700
Closed	00597300000203
Closed	32090800302900
Closed	00471600000200
Closed	28083500307300
Closed	30051400102900
Closed	30073000401100
Closed	00498800100100
Closed	00493900009808
Closed	00810900005000
Closed	00490100000800
Closed	32053300102300
Closed	31063200100300
Renewed	00614800008300
Closed	28072000302600
Closed	28072900400800
Closed	29063400301200
Closed	29063400301300

Accessory Dwelling Units

Index # - File Name: 1.0022 - Single Family Dwellings Data\_Snohomish County.pdf

Closed	32053200204900
Closed	31041700300800
Closed	30040100100200
Closed	00625900003201
Closed	31042600300200
Closed	29060500203800
Closed	00403800015100
Closed	31060400400700
Closed	32050700101000
Closed	32040800301500
Closed	00492500000400
Closed	00494511301702
Closed	00579100001702
Closed	00579100001705
Closed	32041400201100
Closed	32052100101300
Closed	32063200202500
Issued	32052900402800
Closed	32052900103400
Closed	32042600402400
Closed	32042500100500
Closed	00394405004900
Issued	00394507100200
Closed	00394507100200
Closed	00464600002900
Closed	00464200001400
Closed	31042700100400
Renewed	31043400200800
Closed	31043400404600
Closed	31061900202500
Closed	31051700200600
Closed	31041000102600
Closed	31051300201200
Closed	31060800200700
Closed	31060500302900
Closed	00384500001900
Closed	00385300001600
Closed	00543800004200
Closed	00543800004600
Closed	00489200000100
Closed	00489100010301
Issued	00579800000606
Renewed	00600200001301
Closed	00617400002600
Closed	00625200008100
Renewed	00551500007200
Closed	00551500004600

Accessory Dwelling Units

Index # - File Name: 1.0022 - Single Family Dwellings Data\_Snohomish County.pdf

Closed	30040200102900
Closed	00625900003600
Closed	00581700001104
Closed	00597500000207
Closed	00492000102000
Closed	00397700003100
Closed	30060200303400
Closed	30050700100300
Closed	30060700101700
Issued	30051200101300
Closed	30062000304000
Closed	30061800100600
Closed	30061700400300
Closed	00574100002400
Closed	00574200008600
Closed	00574200005300
Closed	00574100011700
Closed	00574100011200
Closed	00610300001500
Closed	00608100600307
Closed	00608500300309
Closed	00493900010001
Closed	00427700001300
Closed	00420500000500
Closed	29061900100800
Closed	29061900103500
Closed	29061700301800
Closed	29062000304200
Closed	29062200202800
Closed	29062300101600
Closed	29062500200600
Closed	29063400402100
Closed	29073100301500
Closed	29051100301900
Closed	29061100402100
Closed	29061500103300
Closed	29061400400200
Closed	28060200400900
Closed	28050300102000
Closed	28050200103200
Issued	28050200100700
Closed	00708900001600
Closed	00761200004100
Closed	00736000002900
Closed	00776400001000
Closed	00802400000500
Closed	28051200203000



Accessory Dwelling Units

Index # - File Name: 1.0022 - Single Family Dwellings Data\_Snohomish County.pdf

Closed	28061200203900
Closed	28061200203600
Closed	28070700400900
Closed	28072600102100
Closed	28072500102300
Closed	28072300101000
Closed	28063200102500
Closed	31042200102600
Renewed	28083500306500
Closed	00509800001400
Closed	00512000204800
Closed	00512000208500
Closed	00512100001300
Closed	00545900001200
Closed	00629900000500
Closed	00631900003600
Closed	00430400001900
Closed	00433200001400
Closed	00433100004300
Closed	00461000500506
Closed	00461001001103
Closed	00460200017100
Closed	00460100007400
Closed	00413400000700
Closed	00373003100305
Closed	00373101100102
Closed	00389400100300
Closed	27062800402600
Closed	27073000201100
Closed	27062800102400
Closed	27052500103400
Renewed	27052700102100
Closed	27052400305500
Closed	00372801400104
Closed	00373002400300
Closed	00373002204202
Closed	27073200400100
Closed	27063300102000
Closed	27053500404700
Closed	27053500103400
Closed	27043500101200
Issued	27062000102900
Issued	27062000200800
Closed	27071300200400
Closed	27090400401500
Closed	27070300102300
Closed	27051100101400

Accessory Dwelling Units

Index # - File Name: 1.0022 - Single Family Dwellings Data\_Snohomish County.pdf

Closed	27071000401000
Closed	27050900106000
Closed	29052600207400
Closed	32061000100600
Closed	28082100402100
Closed	29070800101000
Closed	29070800101300
Issued	29070800100300
Closed	29062600300200
Closed	00868400002200
Closed	29073400300500
Closed	29073400401500
Closed	29073400300200
Closed	29061000103200
Closed	00489100008100
Closed	29061400302800
Closed	30073200101900
Renewed	32070900201000
Closed	32063600100400
Closed	30061300202400
Closed	30070700303500
Issued	27052200303200
Closed	28072100201700
Closed	27053500103500
Closed	01034500001900
Closed	31061800300900
Closed	30072900303100
Closed	29070500102300
Closed	00509300002002
Closed	32042500200800
Closed	28083600305500
Closed	28051600201200
Closed	30073000301600
Issued	00960012900700
Issued	00373300501202
Closed	00394405702100
Closed	01056400001200
Closed	30040100200600
Closed	01069300000200
Closed	01069300000300
Closed	01069300000500
Closed	01069300001200
Closed	01069300001400
Closed	01069300001500
Closed	01069300001600
Closed	01069300001700
Closed	00556600009500

Accessory Dwelling Units

Index # - File Name: 1.0022 - Single Family Dwellings Data\_Snohomish County.pdf

Closed	32042800102200
Closed	01075700000700
Closed	01072800000500
Issued	01149300001000
Closed	01149300001400
Closed	01149300001500
Closed	01149300000100
Closed	01149300000200
Closed	01149300000300
Closed	01149300000500
Closed	01149300000600
Closed	01149300000700
Closed	01149300002300
Closed	01149300001200
Closed	28062500200700
Closed	28052100101800
Closed	31042200203500
Closed	30040200200100
Closed	31040900101600
Closed	01053400003100
Closed	29062300105600
Closed	30063200301100
Closed	00513100000206
Closed	01085000000300
Closed	01085000000400
Closed	31061800203400
Closed	31032500400900
Closed	31032500401000
Closed	28052700101900
Closed	00440700000302
Closed	01128000003300
Closed	01128000002600
Closed	01128000002700
Closed	01128000002800
Closed	01128000004300
Issued	28073500303300
Closed	01128000003800
Closed	01128000003900
Closed	01128000004000
Renewed	01109500001400
Closed	27051000302400
Closed	32051800202400
Closed	28062400401200
Closed	01098900000700
Issued	27052800208800
Closed	27052800208900
Closed	29052300203500

Accessory Dwelling Units

Index # - File Name: 1.0022 - Single Family Dwellings Data\_Snohomish County.pdf

Closed	28083600306500
Closed	29070900100900
Closed	00585200000100
Closed	00585200000100
Closed	01167700004400
Closed	01167700004100
Closed	01167700004800
Closed	01167700005000
Closed	01167700005200
Closed	01167700005400
Closed	01167700005600
Closed	01167700005700
Closed	01167700005900
Closed	01167700006000
Closed	01167700006100
Closed	01167700006200
Closed	01167700006300
Closed	01167700006400
Closed	01167700006500
Closed	01167700006600
Closed	01167700006700
Closed	27051600304300
Closed	31062000103900
Closed	31062000103800
Closed	01164900006500
Closed	01164900006600
Closed	01164900006700
Closed	01167700000100
Closed	01167700000200
Closed	01167700000300
Closed	01167700000400
Closed	01167700000500
Closed	01167700000600
Closed	01167700000700
Closed	01167700000800
Closed	01167700000900
Closed	01167700001000
Closed	01167700001100
Issued	01167700001200
Closed	01167700001300
Closed	01167700001400
Closed	01167700001500
Closed	01167700001600
Closed	01167700001700
Closed	01167700001800
Closed	01167700001900
Closed	01167700002000

Accessory Dwelling Units

Index # - File Name: 1.0022 - Single Family Dwellings Data\_Snohomish County.pdf

Closed	01167700002100
Closed	01167700002200
Closed	01167700002400
Closed	01167700002600
Closed	01167700002800
Closed	01167700003000
Closed	01167700003200
Closed	00591200200300
Closed	01164900000100
Closed	01164900000200
Closed	01164900000300
Closed	01164900000400
Closed	01164900000500
Closed	01164900000600
Closed	01164900000700
Closed	01164900000800
Closed	01164900000900
Closed	01164900001000
Closed	01164900001100
Closed	01164900001200
Closed	01164900001300
Closed	01164900001400
Closed	01164900001500
Closed	01164900001600
Closed	01164900001700
Closed	01164900001800
Closed	01164900001900
Closed	01164900002000
Closed	01164900002100
Closed	01164900002200
Closed	01164900002300
Closed	01164900002400
Closed	01164900002500
Closed	01164900002600
Closed	01164900002700
Closed	01164900002800
Closed	01164900002900
Closed	01164900003000
Closed	01164900003100
Closed	01164900003200
Closed	01164900003300
Closed	01164900003400
Closed	01164900003500
Closed	01164900003600
Closed	01164900003700
Closed	01164900003800
Issued	01164900003900



Accessory Dwelling Units

Index # - File Name: 1.0022 - Single Family Dwellings Data\_Snohomish County.pdf

Closed	00608500300303
Closed	00490400000500
Closed	01162400000900
Closed	01162400000700
Closed	00372900700502
Closed	28051100100400
Closed	00373300501002
Closed	00373300501002
Closed	00373300501002
Closed	00373300501002
Closed	00373300501002
Closed	00373300501002
Closed	00373300501002
Closed	00373300501002
Closed	00373300501002
Closed	00373300501002
Closed	00373300501002
Closed	00373300501002
Closed	00373300501002
Closed	00373300501002
Closed	00373300501002
Closed	00373300501002
Closed	00373300501002
Closed	00373300501002
Closed	00373300501002
Closed	00373300501002
Closed	00373300501002
Closed	00373300501002
Closed	00373300501002
Closed	00373300501002
Closed	00373300501002
Closed	00373300501002
Closed	00373300501002
Closed	00373300501002
Closed	00373300501002
Closed	00373300501002
Closed	00373300501002
Closed	00373300501002
Closed	00373300501002
Closed	00373300501002
Closed	00373300501002
Closed	00373300501002
Closed	00373300501002
Closed	00373300501002
Closed	00373300501002
Closed	00373300700707
Closed	00373300700709
Closed	00373300700711
Renewed	00373300700712
Closed	32042400103300
Closed	32042400103400
Closed	32042400402200
Closed	32042400402300

Accessory Dwelling Units

Index # - File Name: 1.0022 - Single Family Dwellings Data\_Snohomish County.pdf

Closed	28053600106100
Closed	01160400001000
Closed	01159600000400
Closed	01160400000500
Closed	01156200002300
Closed	01156200002400
Closed	01156200002500
Closed	01156200002600
Closed	01156200002700
Closed	01156200001900
Closed	01156200002000
Closed	01156200002100
Closed	01156000000100
Closed	01156000000200
Closed	01156000000300
Closed	01156000000400
Closed	01156000000500
Closed	01156000000600
Closed	01156000000700
Closed	01156000000800
Closed	01156200000100
Closed	01156200000200
Closed	01156200000300
Closed	01156200000400
Closed	01156200000500
Closed	01156200000600
Closed	01156200000700
Closed	01156200000800
Closed	01156200000900
Closed	01156200001000
Closed	01156200001100
Closed	01156200001200
Closed	01156200001300
Closed	01156200001400
Closed	01156200001500
Closed	01156200001600
Closed	30061400403900
Closed	00611300017202
Closed	01159700001900
Closed	01159700002000
Closed	29062000212400
Closed	29062000212500
Issued	01159700003900
Closed	01159700008300
Closed	01159700008400
Closed	01159700008500
Closed	01159700008600



Accessory Dwelling Units

Index # - File Name: 1.0022 - Single Family Dwellings Data\_Snohomish County.pdf

Closed	01159700008700
Closed	01159700008800
Closed	01159700008900
Closed	01159700009000
Closed	01159700000100
Closed	01159700000200
Closed	01159700000300
Closed	01159700000400
Closed	01159700000500
Closed	01159700000600
Closed	01159700000700
Closed	01159700000800
Closed	01159700000900
Closed	01159700001000
Closed	01159700001100
Closed	01159700001200
Closed	01159700001300
Closed	01159700001400
Closed	01159700001500
Closed	01159700001600
Closed	01159700001700
Renewed	00374100100110
Closed	00374100100111
Closed	00374100100112
Closed	01153600001600
Closed	01153600001700
Closed	28061600203500
Closed	01155500000100
Closed	01155500000200
Closed	01155500000300
Closed	01155500000400
Closed	01155500000500
Closed	01155500000600
Closed	01155500000700
Closed	01155500000800
Closed	01155500000900
Closed	01155500001000
Closed	01155500001100
Closed	00492300002201
Closed	00490100003300
Closed	00490100003500
Closed	00490100003400
Closed	01157500000100
Closed	00372800701504
Closed	00559900001700
Closed	01170900000100
Closed	01170900000200



Accessory Dwelling Units

Index # - File Name: 1.0022 - Single Family Dwellings Data\_Snohomish County.pdf

Closed	00372900900104
Closed	00372900900104
Closed	00372900900104
Closed	00372900900104
Closed	00372900900104
Closed	00372900900104
Closed	00372900900104
Closed	00372900900104
Closed	00372900900104
Closed	00372900900104
Closed	00372900900104
Closed	00372900900104
Closed	00372900900104
Closed	00372900900104
Closed	00372900900104
Closed	00372900900104
Closed	00372900900104
Closed	00372900900104
Closed	00372900900104
Closed	00372900900104
Closed	00372900900104
Issued	00380900200300
Closed	32040900302200
Closed	30062800300400
Closed	32041600300500
Closed	28060200305600
Closed	28060200305700
Closed	28060200305800
Closed	28060200305900
Closed	28060200403400
Closed	28060200306000
Closed	28060200306100
Closed	01166400001700
Closed	01166400001800
Closed	01166400001900
Closed	01166400002000
Closed	01166400002100
Closed	01166400002200
Closed	01166400002300
Closed	01166400002400
Closed	01166400002500
Closed	28072100201700
Closed	00372801100502
Closed	00372801100502
Closed	00372801100502
Closed	00372801100502
Closed	01168700000500
Closed	01168700000600
Closed	01168700000700
Closed	01168700000800

Accessory Dwelling Units

Index # - File Name: 1.0022 - Single Family Dwellings Data\_Snohomish County.pdf

Closed	0116870000900
Closed	01168700001000
Closed	01168700001100
Closed	01168700001200
Closed	01168700001300
Closed	01168700001400
Closed	01168700001500
Closed	00373002301700
Closed	00373002301700
Closed	00373002301700
Closed	00373002301700
Closed	00373002301700
Closed	00373002301700
Closed	00373002301700
Closed	00373002301700
Closed	00373002301700
Closed	00373002301700
Closed	00373002301700
Closed	00373002301700
Closed	00373002301700
Closed	00373002301700
Closed	00373002301700
Closed	00373002301700
Closed	00373002301700
Closed	00373002301700
Closed	00373002301700
Closed	00373002301700
Closed	00373002301700
Closed	00373002301700
Closed	00373002301700
Closed	00373002301700
Closed	00373002301700
Closed	00373002301700
Closed	00373002301700
Closed	00373002301700
Closed	00373002301700
Closed	00373002301700
Closed	30051300101000
Closed	00568700400901
Closed	00568700400901
Closed	00568700400901
Closed	00568700400901
Closed	00568700400901
Closed	00568700400901
Closed	00568700400901
Closed	00568700400901
Closed	00568700400901
Closed	01165100000100
Closed	01165100000200
Closed	01165100000300
Closed	01165100000400
Closed	01165100000600
Closed	01165100000700
Closed	01165100000800
Closed	01165100000900
Closed	01165100001000
Closed	01165100001100
Closed	01165100001200
Closed	01165100001300
Closed	01165100001400
Closed	01165100001500
Closed	01165100001600











Accessory Dwelling Units

Index # - File Name: 1.0022 - Single Family Dwellings Data\_Snohomish County.pdf

Closed	00380900200300
Closed	00380900200300
Closed	00380900200300
Closed	00440900002400
Closed	29070900301600
Closed	01164700000100
Closed	01164700000200
Closed	01164700000300
Closed	01164700000800
Closed	01164700000900
Closed	01164700001000
Closed	01164700001100
Closed	01164700001200
Closed	01164700001300
Closed	01164700001400
Closed	01164700001700
Closed	01164700001800
Closed	01164700001900
Closed	01164700002000
Closed	01164700002200
Closed	01164700002300
Closed	01164700002400
Closed	01164700002500
Closed	01164700002600
Closed	01164700002700
Closed	01164700002800
Closed	01164700002900
Closed	01164700003000
Closed	01164700003100
Closed	01164700003200
Closed	01164700003300
Closed	01164700003400
Closed	01164700003600
Closed	01164700003700
Closed	01164700003800
Closed	01164700003900
Closed	01164700004000
Closed	01164700004100
Closed	01164700004200
Closed	01164700004300
Closed	01164700004400
Closed	01164700004500
Closed	01164700004600
Closed	01164700004700
Closed	01164700004800
Closed	01164700004900
Closed	01164700005000



Accessory Dwelling Units

Index # - File Name: 1.0022 - Single Family Dwellings Data\_Snohomish County.pdf

Closed	00373700601806
Closed	00373700601806
Closed	00373700601806
Closed	00373700601806
Closed	00373700601806
Closed	00373700601806
Closed	00373700601806
Closed	00373700601806
Closed	00373700601806
Closed	00373700601806
Closed	00373700601806
Closed	00373700601806
Closed	00373700601806
Closed	00373700601806
Closed	00373700601806
Closed	01164200000400
Closed	01164200000500
Closed	01164200000600
Closed	01164200000700
Closed	01164200000800
Closed	01164200000900
Closed	01164200001000
Closed	01164200001100
Closed	01164200001200
Closed	01164200001300
Closed	01164200001400
Closed	01164200001500
Closed	01164200001600
Closed	01164200001700
Closed	01164200001800
Closed	01164200001900
Closed	01164200002000
Closed	01164200002100
Closed	01164200002200
Closed	00375000000700
Closed	00375000000700
Closed	00375000000700
Closed	00375000000700
Closed	00375000000700
Closed	00375000000700
Closed	00375000000700
Closed	00375000000700
Closed	00375000000700
Closed	00375000000700
Closed	30060700400600
Closed	29062000103700
Closed	29061400101200
Closed	01166800000100
Closed	01166800000200

Accessory Dwelling Units

Index # - File Name: 1.0022 - Single Family Dwellings Data\_Snohomish County.pdf

Closed	0116680000300
Closed	0116680000400
Closed	0116680000500
Closed	0116680000600
Closed	0116680000700
Closed	0116680000800
Closed	0116680000900
Closed	0116680001000
Closed	0116680001800
Closed	0116680001900
Closed	0116680002000
Closed	0116680002100
Closed	0116680002200
Closed	0116680002500
Closed	0116680002600
Closed	0116680002700
Closed	0116680002800
Closed	0116680002900
Closed	0116680003000
Closed	0116680003100
Closed	0116680003200
Closed	0116680003300
Closed	0116680003400
Closed	0116680003500
Closed	0116680003600
Closed	0116680003700
Closed	0116680003800
Closed	0116680003900
Closed	0116680004000
Closed	0116680004100
Closed	0116680004200
Closed	0116680004300
Closed	0116680004400
Closed	0116680004500
Closed	0116680004600
Closed	0116680004700
Closed	0116680004800
Closed	0116680004900
Closed	0116680005000
Closed	0116680005100
Closed	0116680005200
Closed	0116680005300
Closed	0116680005400
Closed	0116680005500
Closed	0116680005600
Closed	0116680005700
Closed	0116680005800

Accessory Dwelling Units

Index # - File Name: 1.0022 - Single Family Dwellings Data\_Snohomish County.pdf

Closed	01166800005900
Closed	01166800006000
Closed	01160500000300
Closed	01160500000400
Closed	01160500000500
Closed	01163200002200
Closed	01163200002500
Closed	01163200002600
Closed	01163200002700
Closed	01161500000800
Closed	01161500000900
Closed	01163200001800
Closed	01163200001900
Closed	32062800303200
Closed	32063400303500
Closed	32063400303600
Closed	01163000000300
Closed	01163000000400
Closed	01163000000500
Closed	28051100303500
Closed	01160500001500
Closed	01160500001600
Closed	01160500001700
Closed	01160500001800
Closed	01160500001900
Closed	01160500002000
Closed	01160500002100
Closed	01160500002200
Closed	01160500002300
Closed	01160500002400
Closed	01160500002500
Closed	01160500002600
Closed	01160500002700
Closed	01164000000700
Closed	01164000000800
Closed	01164000000900
Closed	01164000001000
Closed	01164000001100
Closed	01164000001200
Closed	01164000001300
Closed	32051800101300
Closed	01160500000700
Closed	01160500000800
Closed	01160500000900
Closed	01160500001000
Closed	01160500001300
Closed	01152200000200

Accessory Dwelling Units

Index # - File Name: 1.0022 - Single Family Dwellings Data\_Snohomish County.pdf

Closed	01152200003100
Closed	01152200000400
Closed	32042700203100
Closed	01149100003000
Closed	01149100001900
Closed	01149100002000
Closed	01145800000300
Closed	01140800000400
Closed	32092300204600
Closed	01149400001200
Closed	00413400001000
Closed	01160200000900
Closed	01160200001000
Closed	01160200001200
Closed	01160200001300
Closed	01160200001400
Closed	01160200001500
Closed	01160200001600
Closed	01160200001700
Closed	01151900001100
Closed	01151900000100
Closed	01151900000200
Closed	01151900000300
Closed	01151900000400
Closed	01155700002300
Closed	01155700002400
Closed	01155700002500
Closed	01155700002600
Closed	01155700001900
Closed	01155700000500
Closed	01155700000600
Closed	01155700000700
Closed	01155700000800
Closed	01155700000900
Closed	00617300101400
Closed	01155700000100
Closed	28062900402200
Closed	00960002407100
Closed	00373002501203
Closed	00373002501203
Closed	01153600002400
Closed	01153600002500
Closed	01166700000500
Closed	01166700000600
Closed	01166700000700
Closed	01166700001200
Closed	01166700001300

Accessory Dwelling Units

Index # - File Name: 1.0022 - Single Family Dwellings Data\_Snohomish County.pdf

Closed	01166700001400
Closed	01153600002000
Closed	01153600002100
Closed	01153600000500
Closed	01153600002800
Closed	01153600002900
Closed	01153600003000
Closed	01153600003100
Closed	01153600003200
Closed	01153600003300
Closed	01153600003400
Closed	01153600003500
Closed	01153600003600
Closed	01153600003700
Closed	01153600003800
Closed	01153600003900
Closed	01153600004000
Closed	01153600004100
Closed	01166700000200
Closed	01153600000800
Closed	01153600000900
Closed	01153600001000
Closed	01153600001100
Closed	01153600001200
Closed	01153600001300
Closed	01153600001400
Closed	01152100004800
Closed	01152100004900
Closed	01152100005000
Closed	01152100005100
Closed	01152100005200
Closed	01152100005300
Closed	01152100006600
Closed	01152100004400
Closed	01152100004500
Closed	01152100004600
Closed	01152100004700
Closed	01152100004100
Closed	01152100003900
Closed	01152100002600
Closed	01152100003600
Closed	01152100003700
Closed	01152100002400
Closed	01152100002900
Closed	00370500000300
Closed	01153500004000
Issued	01153500004100

Accessory Dwelling Units

Index # - File Name: 1.0022 - Single Family Dwellings Data\_Snohomish County.pdf

Closed	0115350000100
Closed	0115350000200
Closed	0115350000300
Closed	0115350000400
Closed	0115350000900
Closed	0115350001000
Closed	0115350001100
Closed	0115350001200
Closed	0115350001300
Closed	0115350001400
Closed	0115350001500
Closed	0115350001600
Closed	0115350001700
Closed	27050900106300
Closed	27050900106200
Closed	01153500002100
Closed	01153500004400
Closed	01153500004500
Closed	01153500004600
Closed	01153500004700
Closed	01153500004800
Closed	01153500002400
Closed	01153500002500
Closed	01153500002600
Closed	01153500003700
Closed	01153500003800
Closed	01153500002900
Closed	01153500003000
Closed	01153500003100
Closed	01153500003200
Closed	01153500003300
Closed	01153500003400
Closed	01153500003500
Closed	01133200007400
Closed	28060300401900
Closed	28060300405300
Closed	32052200402400
Closed	00538000009302
Closed	00538000009302
Closed	00538000009301
Closed	00538000009301
Closed	00538000009301
Closed	01126400000500
Closed	31052500300600
Closed	32052600300500
Closed	31042200201500
Renewed	27070200401900



Accessory Dwelling Units

Index # - File Name: 1.0022 - Single Family Dwellings Data\_Snohomish County.pdf

Closed	29070800101400
Closed	01143500001000
Closed	01143500000500
Closed	01143500000600
Closed	32042300104100
Closed	27051800401300
Closed	01160600000200
Closed	00585200003001
Closed	01114100000900
Closed	01114100001000
Issued	01114100001100
Closed	01114100001200
Closed	01109500002500
Closed	01109500002600
Closed	01114100002500
Closed	01114100002600
Closed	01114100002700
Closed	01114100002800
Closed	00635000000100
Closed	01114100003000
Closed	01116800001000
Closed	32042200104000
Closed	30063300403900
Closed	01124700000500
Closed	01124700000600
Closed	01126400001000
Closed	01126400001100
Closed	28072600403800
Closed	01125600000900
Closed	01125600000400
Closed	01150700000100
Closed	01150700000200
Closed	01150700000900
Closed	01150700001000
Closed	00376400000800
Closed	00376400000800
Closed	00376400000800
Closed	00376400000800
Closed	00376400000800
Closed	01172700000900
Closed	01172700001000
Closed	01172700001100
Closed	01172700001200
Closed	01172700001300
Closed	01172700001400
Closed	01172700001500
Closed	28073000300200

Accessory Dwelling Units

Index # - File Name: 1.0022 - Single Family Dwellings Data\_Snohomish County.pdf

Closed	28073000300200
Closed	00394406000402
Closed	01169500000100
Closed	01169500000200
Closed	01169500000300
Closed	01169500000400
Closed	01169500000500
Closed	01169500000600
Closed	01169500000700
Closed	01169500000800
Closed	01169500000900
Closed	01171700000100
Closed	01171700000200
Closed	01171700000300
Closed	01171700000400
Closed	01171700000500
Closed	01171700000600
Closed	01171700000700
Closed	01171700000800
Closed	01171700000900
Closed	01171700001000
Closed	01171700001100
Closed	01168300000100
Closed	01168300000200
Issued	01168300000300
Issued	01168300000400
Issued	01168300000500
Issued	01168300000600
Closed	28070700401600
Closed	27070700402200
Closed	01170000005200
Closed	01170000005300
Closed	01170000005400
Closed	00585200003201
Closed	29063300402300
Closed	27090400201800
Closed	00394402405500
Closed	00394402403700
Closed	01167300001400
Closed	32040400301900
Closed	01167300000300
Closed	01170400002100
Closed	01170400002200
Closed	01170400002300
Closed	01170400002400
Closed	01170400002500
Closed	01167300000100

Accessory Dwelling Units

Index # - File Name: 1.0022 - Single Family Dwellings Data\_Snohomish County.pdf

Closed	01170400002700
Closed	01170400002900
Closed	01170400003300
Closed	01170400003400
Closed	01170400003500
Closed	01170400003800
Closed	01170400004300
Closed	01170400004400
Closed	01170400004500
Closed	01170400004600
Closed	01170400004700
Closed	01170400004800
Closed	01170400004900
Closed	00373300500403
Closed	00394403201301
Closed	01168600000900
Closed	01168600001000
Closed	01168600001100
Closed	01168600001200
Closed	01168600001300
Closed	01168600001400
Closed	01168600001500
Closed	01168600001600
Closed	01168600001700
Closed	01168600001800
Closed	01168600002000
Closed	01168600002100
Closed	01168600002200
Closed	01170000000100
Closed	01170000000200
Closed	01170000000300
Closed	01170000000400
Closed	01170000000500
Closed	01170000001100
Closed	01170000001200
Closed	01170000001300
Closed	01170000001400
Closed	01170000001500
Closed	01170000001600
Closed	01170000001700
Closed	01170000001800
Closed	01170000001900
Closed	01170000002000
Closed	01170000002100
Closed	01170000002200
Closed	01170000002300
Closed	01170000002400









Accessory Dwelling Units

Index # - File Name: 1.0022 - Single Family Dwellings Data\_Snohomish County.pdf

Closed	00373002401002
Closed	00373002401002
Closed	00373002401002
Closed	00625300001500
Closed	00373002302701
Closed	00373002302701
Closed	00373002302701
Closed	00373002302701
Closed	00373002302701
Closed	00373002302701
Closed	00373002302701
Closed	00373002302701
Closed	00373002302701
Closed	00373002302701
Closed	00570300202601
Closed	00570300202601
Closed	00570300202601
Closed	00570300202601
Closed	00570300202601
Closed	00570300202601
Closed	00570300202601
Closed	00570300202601
Closed	00570300202601
Closed	00570300202601
Closed	00570300202601
Closed	00570300202601
Closed	00570300202601
Closed	00570300202601
Closed	00570300202601
Closed	00570300202601
Closed	00570300202601
Closed	00570300202601
Closed	00570300202601
Closed	00373701001601
Closed	00373701001601
Closed	00373701001601
Closed	00373701001601
Closed	00373701001601
Closed	32042500201300
Closed	28051600200900
Closed	29060900208000
Closed	28070800200600
Closed	00590700005100
Renewed	29061100402400
Closed	01178400000300
Closed	01178400000400
Closed	01178400000500
Closed	01178400000600
Closed	01178400000800
Closed	01178400000900
Closed	01178400001300
Closed	01178400001600



Accessory Dwelling Units

Index # - File Name: 1.0022 - Single Family Dwellings Data\_Snohomish County.pdf

Renewed	28070800100300
Closed	01173300003100
Closed	01173300003200
Closed	01173300003300
Closed	01173300003400
Closed	01173300003500
Closed	01173300003600
Closed	01173300003700
Closed	01173300003800
Closed	01173300003900
Closed	01173300004100
Closed	00440200000301
Closed	01171800000100
Closed	01171800000200
Closed	01171800000300
Closed	01171800000400
Closed	01171800000500
Closed	01171800000600
Closed	01171800000700
Closed	01171800000800
Closed	01174600000800
Closed	01174600000500
Closed	00585200003601
Closed	00585200004501
Closed	01175700005000
Closed	01175700005100
Closed	01175700005200
Closed	01175700005300
Closed	01175700005400
Closed	01175700005500
Closed	01175700005600
Closed	01175700005700
Closed	01175700005800
Closed	01175700005900
Closed	01175700006000
Closed	01175700006100
Closed	01175700006200
Closed	01175700006300
Closed	01175700006400
Closed	01175700006500
Closed	01175700006600
Closed	01175700006700
Closed	01175700006800
Closed	01175700006900
Closed	01175700007000
Closed	00394402300200
Closed	01175700000400

Accessory Dwelling Units

Index # - File Name: 1.0022 - Single Family Dwellings Data\_Snohomish County.pdf

Closed	01175700000500
Closed	01175700000600
Closed	01175700000900
Closed	01175700001000
Closed	01175700001100
Closed	01175700001200
Closed	01175700001300
Closed	01175700001400
Closed	01175700001500
Closed	01175700001600
Closed	01175700001700
Closed	01175700001800
Closed	01175700001900
Closed	01175700002000
Closed	01175700002100
Closed	01175700002200
Closed	01175700002300
Closed	01175700002400
Closed	01175700002500
Closed	01175700002600
Closed	01175700002700
Closed	01175700002800
Closed	01175700002900
Closed	01175700003000
Closed	01175700003100
Closed	01175700003200
Closed	01175700003300
Closed	01175700003400
Closed	01175700003500
Closed	01175700003600
Closed	01175700003700
Closed	01175700003800
Closed	01175700003900
Closed	01175700004000
Closed	01175700004100
Closed	01175700004200
Closed	01175700004300
Closed	01175700004400
Closed	01175700004500
Closed	01175700004600
Closed	01175700004700
Closed	01174600001500
Closed	01174600001600
Closed	01174600001900
Closed	01174600002000
Closed	01174600002100
Closed	01174600002200

Accessory Dwelling Units

Index # - File Name: 1.0022 - Single Family Dwellings Data\_Snohomish County.pdf

Closed	01174600002300
Closed	01174600002400
Closed	01174600002500
Closed	01174600002600
Closed	01174600002700
Closed	01174600002800
Closed	01174600002900
Closed	01174600003000
Closed	01174600003100
Closed	01174600003200
Closed	01174600003300
Closed	01174600003400
Closed	01174600003500
Closed	01174600003600
Closed	01174600003700
Closed	01174600003800
Closed	01174600003900
Closed	00563100000300
Closed	27070100301100
Closed	01172800002000
Closed	31050500401400
Closed	31040400400600
Closed	01172800003000
Closed	00373002800305
Closed	00373002800305
Closed	00373002800305
Closed	00373002800302
Closed	00373002800302
Closed	00511000004900
Closed	30040100200500
Closed	00394401900900
Closed	00394401900900
Closed	28061300401800
Closed	00585200003901
Closed	00585200004001
Closed	00585200004101
Closed	00585200004201
Closed	01172800002200
Closed	01172800002300
Closed	01172800002400
Closed	01172800002500
Closed	01172800002600
Closed	01172800002700
Closed	01172800002800
Closed	01172800001000
Closed	01172800001100
Closed	01172800001200

Accessory Dwelling Units

Index # - File Name: 1.0022 - Single Family Dwellings Data\_Snohomish County.pdf

Closed	01172800001300
Closed	01172800001400
Closed	01172800001500
Closed	01172800001600
Closed	01172800001700
Closed	01172800000400
Closed	01172800000500
Closed	01172800000600
Closed	00532100002603
Closed	29062200402700
Closed	32081200301100
Closed	00532100002601
Closed	00394402400100
Closed	00394402408400
Closed	00372801000102
Closed	28081900301200
Renewed	31040100200900
Closed	00509400002303
Closed	01170000004800
Closed	01170000004900
Closed	01170000005000
Closed	01170000005100
Closed	01170000003800
Closed	01170000003900
Closed	00585200003701
Closed	00585200001801
Closed	00585200004302
Closed	01170000002500
Closed	01170000002600
Closed	01170000002700
Closed	01170000002800
Closed	01170000002900
Closed	01170000000600
Closed	01170000000700
Closed	01170000000800
Closed	01170000000900
Closed	01170000001000
Closed	01170400005000
Closed	01170400005100
Closed	01170400005200
Closed	01170400005300
Closed	01170400005400
Closed	01170400005500
Closed	01170400005600
Closed	01170400005700
Closed	01170400005800
Closed	01170400005900

Accessory Dwelling Units

Index # - File Name: 1.0022 - Single Family Dwellings Data\_Snohomish County.pdf

Closed	01170400006000
Closed	01170400002800
Closed	01167300000200
Closed	01170400002600
Closed	01167300000400
Closed	01167300000500
Closed	01167300000600
Closed	01167300000700
Closed	01167300000800
Closed	01167300001000
Closed	01167300001100
Closed	01167300001200
Closed	01167300001300
Closed	00532000002300
Issued	01170400000100
Closed	01170400000200
Closed	01170400000300
Closed	01170400000400
Closed	01170400000500
Closed	01170400000600
Closed	01170400000700
Closed	01170400000800
Closed	01170400000900
Closed	01170400001000
Closed	01170400001100
Closed	01170400001200
Closed	01170400001300
Closed	01170400001400
Closed	01170400001500
Closed	01170400001600
Closed	01170400001700
Closed	01170400001800
Closed	01170400001900
Closed	01170400002000
Closed	30060100302300
Closed	00373000301003
Closed	00533700001200
Closed	28062300403800
Closed	28062300403900
Closed	32042500200600
Closed	32042500200600
Issued	01168300000900
Issued	01168300001000
Issued	01168300001200
Issued	01168300001300
Closed	32062800100900
Closed	30052000401000

Accessory Dwelling Units

Index # - File Name: 1.0022 - Single Family Dwellings Data\_Snohomish County.pdf

Closed	00658100000100
Closed	00658100000100
Closed	00658100000100
Closed	00658100000100
Closed	00394402300100
Closed	01169500001000
Closed	01169500001100
Closed	01169500001200
Closed	01169500001300
Closed	01169500001400
Closed	01169500001500
Closed	01169500001600
Closed	01169500001700
Closed	01169500001800
Closed	01169500001900
Closed	01169500002000
Closed	28071500300800
Issued	01172700001600
Closed	01172700001700
Closed	01172700001800
Closed	01172700001900
Closed	01172700002000
Closed	01172700002100
Closed	01172700002200
Closed	01172700002300
Closed	01172700002400
Closed	00538000007101
Closed	00538000007101
Closed	00538000007101
Closed	00538000007101
Closed	00538000007101
Closed	00538000007101
Closed	00538000007101
Closed	00538000007101
Closed	00538000007101
Closed	00538000007101
Closed	00538000007101
Closed	00538000007101
Closed	00538000007101
Closed	00538000007101
Closed	00538000007101
Closed	00538000007101
Closed	28042400405700
Closed	28042400405700
Renewed	00570600202201
Renewed	00570600202201
Renewed	00570600202201
Renewed	00570600202201
Renewed	00570600202201
Closed	32090900301600



Accessory Dwelling Units

Index # - File Name: 1.0022 - Single Family Dwellings Data\_Snohomish County.pdf

Closed	00373701100500
Closed	00373701100500
Closed	00373701100500
Closed	00373701100500
Closed	00373701100500
Closed	00373701100500
Closed	00373701100500
Closed	00373701100500
Closed	00373701100500
Closed	00373701100500
Closed	00373701100500
Closed	00373701100500
Closed	00373701100500
Closed	00373701100500
Closed	00373701100500
Closed	00373701100500
Closed	00373701100500
Closed	00373701100500
Closed	00373701100500
Closed	00373701100500
Closed	00373701100500
Closed	00373701100500
Closed	00373701100500
Closed	00373701100500
Closed	00373701100500
Closed	00373701100500
Closed	00373701100500
Closed	00373701100500
Closed	00373701100500
Closed	00373701100500
Closed	00373701100500
Closed	00373701100500
Closed	00373701100500
Closed	00373701100500
Closed	00373701100500
Closed	00373701100500
Closed	00397700003000
Closed	00461000600600
Closed	00461000600600
Closed	00461000600600
Closed	00461000600600
Closed	00461000600600
Closed	00461000600600
Closed	00461000600600
Closed	00461000600600
Closed	00461000600600
Closed	00782300000100
Closed	27052800108400
Closed	27052800108600
Closed	27052800108700
Closed	27052800108800
Closed	01177000000100
Closed	011770000001000
Closed	01177000000200
Closed	01177000000300







Accessory Dwelling Units

Index # - File Name: 1.0022 - Single Family Dwellings Data\_Snohomish County.pdf

Closed	00372700100103
Closed	27071100401500
Closed	00492300001500
Closed	00492300001500
Closed	00492300001500
Closed	00492300001500
Closed	00492300001500
Closed	00492300001500
Closed	00492300001500
Closed	30071900208100
Issued	00607900000600
Closed	00373002100103
Closed	00373002100103
Closed	00373002100103
Closed	00373002100103
Closed	00373002100103
Closed	00373002100103
Closed	00373002100103
Closed	00373002100103
Closed	00373002100103
Closed	00373002100103
Closed	00373002100103
Closed	00373002100103
Closed	00373002100103
Closed	00373002100103
Closed	00372700100103
Closed	31061800400700
Closed	00625200008700
Closed	28052800102900
Closed	28052800103000
Closed	28072300401400
Closed	28072300401500
Closed	28072300401600
Closed	28052700101700
Issued	00394405001501
Closed	30061400300400
Closed	01180600001800
Closed	01180600001900
Issued	01180600002600
Closed	01180600002700
Closed	01182100000100
Closed	01182100001200
Closed	01182100001300
Closed	01182100001400
Closed	01182100001800
Closed	01181000000100
Closed	01181000000200
Closed	01181000000300
Issued	01181000000400
Closed	01181000000400

Accessory Dwelling Units

Index # - File Name: 1.0022 - Single Family Dwellings Data\_Snohomish County.pdf

Closed	0118100000500
Closed	0118100000600
Closed	0118100000700
Closed	0118100002300
Closed	0118100002400
Closed	0118100002500
Closed	0118100002600
Closed	0118100002700
Closed	0118100002800
Closed	0118100002900
Closed	0118100003000
Closed	0118100003100
Closed	0118100003600
Closed	0118100003700
Closed	0118100003800
Closed	0118100003900
Closed	0118100004000
Closed	00373002101704
Closed	00373002101704
Closed	00373002101704
Closed	00373002101704
Closed	00373002101704
Closed	00585200003702
Closed	00585200004301
Closed	01125900003900
Closed	01126400001200
Closed	01126400000100
Closed	01126400000200
Closed	01126400000300
Closed	01126400000400
Closed	01124700000400
Closed	01124700000200
Closed	01114100002900
Closed	01114100001700
Closed	01114100001300
Closed	01114100001400
Closed	01114100002000
Closed	01114100002100
Closed	27051800401300
Closed	27051800401300
Closed	01143500001100
Issued	01143500000800
Closed	01143500000900
Closed	31060900303400
Closed	01139200003000
Closed	01139200003100
Closed	30060100302500

Accessory Dwelling Units

Index # - File Name: 1.0022 - Single Family Dwellings Data\_Snohomish County.pdf

Renewed	00494511400200
Closed	30060100302600
Closed	30060100302700
Closed	30060100302100
Closed	30060100302200
Closed	01133200007000
Closed	01133200007100
Closed	00597300001101
Closed	01153500003600
Closed	01153500003900
Closed	01152100000100
Closed	01152100000200
Closed	01152100000300
Closed	01153500002200
Closed	01153500002300
Closed	00473300600800
Closed	01153500002000
Closed	01152100001800
Closed	01152100001900
Closed	01152100002000
Closed	01152100002100
Closed	01152100002200
Closed	01152100000600
Closed	01152100003000
Closed	01152100003100
Closed	01152100003200
Closed	01152100003300
Closed	01152100003400
Closed	01152100004700
Closed	01152100005500
Closed	01152100005600
Closed	01152100005700
Closed	01152100005800
Closed	01152100005900
Closed	01152100006000
Closed	01152100006100
Closed	01152100006200
Closed	01152100006300
Closed	01152100006400
Closed	01152100006500
Closed	01152100006700
Closed	01152100006800
Closed	01152100006900
Closed	32040900302100
Closed	01153600001500
Closed	01166700000300
Closed	29062500400400

Accessory Dwelling Units

Index # - File Name: 1.0022 - Single Family Dwellings Data\_Snohomish County.pdf

Closed	31051700202200
Closed	31051700202300
Closed	31051700202400
Closed	00491400200409
Closed	01149400001300
Closed	01149400001400
Closed	01149400001500
Closed	28082100200700
Closed	28082100200400
Issued	29072800201400
Closed	00509300003500
Closed	00509300003500
Closed	00509300003500
Issued	29062500400200
Closed	29063500100300
Closed	29063500100300
Renewed	00677100005300
Closed	00568700400901
Closed	00373701500201
Closed	01163600000400
Closed	01163600000500
Closed	01163600000600
Closed	01163600000700
Closed	01163600000800
Closed	01163600000900
Closed	01163600001000
Closed	29053500400500
Closed	01168700001700
Closed	01168700001800
Issued	01168700001900
Closed	01168700002000
Closed	01168700000100
Closed	01168700000200
Closed	01168700000300
Closed	01168700000400
Renewed	01163600001500
Renewed	01163600001600
Closed	01163600001700
Closed	28060200305300
Closed	28060200305400
Closed	28060200305500
Closed	01164600000500
Closed	28060200306200
Closed	28060200306300
Closed	28060200306400
Closed	28060200403500
Closed	28060200306500

Accessory Dwelling Units

Index # - File Name: 1.0022 - Single Family Dwellings Data\_Snohomish County.pdf

Closed	00625300002701
Closed	00625300002702
Closed	00625300002704
Renewed	00443000002200
Closed	01170900001400
Closed	01170300000200
Closed	01170300000300
Closed	01170300000400
Closed	01164100000100
Closed	01164100000200
Closed	01164100000300
Closed	01164100000400
Closed	01164100000500
Closed	01164100000600
Closed	00394510200800
Closed	30063000301700
Renewed	01157500000600
Closed	27051700203500
Closed	00394401101000
Closed	29073400300100
Closed	01164900006400
Closed	01167700005800
Closed	01167700005500
Closed	01167700005300
Closed	01167700005100
Closed	01167700004900
Closed	01167700004200
Closed	01167700004300
Closed	01167700004500
Closed	01167700004600
Closed	01167700004700
Renewed	00466200010700
Closed	01167700003600
Closed	01167700003700
Closed	01167700003800
Closed	01167700003900
Closed	01167700004000
Closed	27051500107100
Closed	00520200000900
Closed	31052400100300
Closed	30070100301400
Closed	30070100301500
Closed	30070100301600
Closed	29071800301600
Closed	29071800301300
Closed	29071800301400
Closed	29071800300900

Accessory Dwelling Units

Index # - File Name: 1.0022 - Single Family Dwellings Data\_Snohomish County.pdf

Closed	29071800301100
Closed	28082100201500
Closed	28082100201400
Closed	27072000400100
Closed	01085000000600
Closed	01085000000700
Closed	01085000000800
Closed	01085000000900
Closed	01085000000100
Closed	01085000000200
Closed	32073000403000
Closed	30063000401700
Closed	30061400303700
Closed	00608100100305
Closed	01053400000900
Closed	01053400001100
Closed	01053400001200
Closed	31040900101700
Issued	28082100400100
Renewed	31060500300500
Closed	28053600403000
Closed	01149300001300
Closed	01149300001900
Closed	01149300002400
Closed	01149300002200
Closed	01149300000800
Closed	01149300000900
Closed	01149300000400
Closed	01149300001600
Closed	01149300001700
Closed	01149300001100
Closed	01069300000800
Closed	01069300001300
Closed	01069300000100
Closed	01056400000600
Renewed	00499100201405
Closed	00958700004300
Closed	29063200401000
Closed	31051700100400
Closed	00935400000100
Closed	31053400401200
Closed	00422500004500
Closed	32072900201400
Closed	32042600200600
Closed	32063300402300
Closed	32051300201400
Closed	01010700000200



Accessory Dwelling Units

Index # - File Name: 1.0022 - Single Family Dwellings Data\_Snohomish County.pdf

Closed	01028800000500
Closed	32080100301400
Closed	28061600102500
Closed	28083600305700
Closed	29070500101000
Closed	30072900302900
Closed	30073000401700
Closed	30073200401200
Closed	30072900303300
Closed	31061800300300
Closed	28073000105100
Renewed	00473300001628
Closed	00473300001630
Closed	00901200000600
Issued	32040600100200
Closed	00373002102801
Renewed	28062900401900
Closed	28062400300400
Closed	29062200401300
Closed	29062200401300
Closed	28052100102000
Closed	30063400100700
Closed	29061300201900
Closed	28073300401200
Issued	30062500101600
Closed	29061000103100
Closed	29061500302200
Closed	00492000302200
Closed	00608100400407
Closed	31041000200600
Closed	00394400203500
Issued	30072000400400
Closed	30060100300100
Issued	28070800201400
Closed	27070900100400
Closed	27051000403500
Closed	27051100205900
Closed	27051100302000
Closed	27041400303300
Closed	27051500101200
Closed	27052100402800
Closed	27061900103400
Renewed	27061800402100
Closed	27053300102700
Closed	27053300105000
Closed	27053300105800
Closed	27053300105900

Accessory Dwelling Units

Index # - File Name: 1.0022 - Single Family Dwellings Data\_Snohomish County.pdf

Closed	27053300106000
Closed	00373002901204
Closed	00373002100402
Renewed	00373001200800
Closed	00372900600902
Closed	27052200304400
Closed	27052700401800
Issued	27062800400100
Closed	27062700401600
Issued	27062900401000
Closed	00375200000900
Closed	00373700100602
Issued	00373003100403
Closed	00461000900902
Closed	00460200016700
Closed	00430400001800
Closed	00631900001400
Closed	00577600400600
Closed	00583000002500
Closed	00513700003706
Closed	00526100506300
Closed	00375000003100
Renewed	00374700000604
Closed	00380900100703
Closed	28073400300800
Closed	28072600200600
Renewed	28070800200900
Closed	28061200203700
Closed	28061200101200
Closed	28061700200900
Closed	28071600300400
Closed	28071800203300
Closed	00760500004600
Closed	00703000000800
Closed	00668600000200
Closed	28060200403200
Closed	28060400100400
Issued	29061400100800
Closed	29060400102000
Renewed	29062600301600
Closed	29062300300300
Closed	29062100208000
Closed	00604100001301
Closed	00603100200700
Closed	00597400000114
Renewed	00574100006600
Renewed	00574000005300

Accessory Dwelling Units

Index # - File Name: 1.0022 - Single Family Dwellings Data\_Snohomish County.pdf

Closed	00574000009403
Closed	30061900100500
Closed	30061900401300
Closed	30061400404800
Closed	30061500400800
Closed	30060700201300
Renewed	30051200300600
Closed	30051200200200
Closed	30040600101800
Closed	30050600201600
Closed	30040300203200
Closed	00454000001400
Closed	00471400003000
Closed	00597300000307
Closed	00597200000700
Closed	30040100102500
Issued	30060100300200
Closed	00611300010700
Renewed	00554300000600
Closed	00590700005200
Closed	00582700801600
Closed	00579700000102
Renewed	00489000001200
Closed	00470600006200
Closed	30062800300200
Closed	30052500401900
Closed	30063000402800
Closed	31040700400300
Closed	31042200305700
Closed	31042600402000
Closed	31053400400100
Closed	31053400401100
Closed	31043400404500
Closed	00394401005700
Closed	00394401607400
Renewed	31042700100400
Closed	31042700100500
Closed	31063100401400
Closed	31063200201300
Closed	00482900006700
Closed	00394510701100
Closed	00394507001000
Closed	00394406201201
Closed	00394402300702
Closed	32062100101100
Closed	32052300100500
Closed	32053200203400

Accessory Dwelling Units

Index # - File Name: 1.0022 - Single Family Dwellings Data\_Snohomish County.pdf

Closed	32051800300500
Closed	32061200400200
Closed	32041000200800
Closed	00499100103200
Closed	00494511501403
Closed	32040800101800
Closed	32050900202300
Closed	32050700101100
Issued	32040500300300
Issued	27050900201900
Issued	30061500201200
Closed	30060400201000
Closed	27070100200400
Closed	30063400100500
Closed	30061400302600
Closed	29073400300300
Closed	00590300000400
Closed	32053400102100
Closed	32063300200100
Closed	32063400300700
Closed	32043600401100
Closed	00490300000700
Closed	27043600301500
Closed	30062800200100
Closed	00629600001000
Renewed	28070300100300
Renewed	30072900101400
Closed	00609600000800
Closed	29070800100600
Renewed	00492000104600
Closed	00394406600600
Closed	00589600000700
Closed	32063200404600
Closed	30060800101400
Issued	31063200400900
Issued	00492000203901
Issued	31042700400300
Issued	32063300400400
Issued	27090900200900
Issued	00544100002400
Issued	30060600400600
Closed	29060500200900
Issued	32042500300700
Closed	27061600203500
Issued	30060200104000
Issued	28083000402200
Issued	32040500401400

Accessory Dwelling Units

Index # - File Name: 1.0022 - Single Family Dwellings Data\_Snohomish County.pdf

Issued	32090700300600
Issued	32080200301100
Closed	00659800000100
Closed	00659800000200
Issued	32040400102800
Issued	00494600100901
Issued	00494600301100
Closed	32081100200800
Closed	32071000201600
Closed	32081300100400
Closed	32053200203200
Closed	32063100304000
Issued	32062900101900
Closed	32042300200700
Issued	32042500400500
Closed	32042500100400
Closed	00394402300701
Closed	00464600002700
Issued	00384600001000
Closed	00379500001001
Issued	31063400101300
Issued	31042100401200
Closed	31040800302400
Issued	31040500202600
Closed	31040200401100
Closed	30062900401200
Closed	30063400302600
Closed	00543400002500
Closed	00543300009300
Closed	00543800000302
Closed	01094300006900
Closed	01094300007000
Closed	00631600007200
Closed	00631600007300
Issued	00557200400500
Issued	00611300000600
Closed	00492100000400
Closed	00397700001601
Issued	00440200000701
Closed	00397700000700
Closed	30060300101000
Issued	30060600401200
Closed	30060600200500
Issued	30060600301500
Closed	30061300303800
Issued	30061900200200
Closed	30061700401000

Accessory Dwelling Units

Index # - File Name: 1.0022 - Single Family Dwellings Data\_Snohomish County.pdf

Closed	30062000304100
Issued	00574100004400
Issued	00597400004900
Closed	00399200000500
Closed	00399200001700
Issued	00459700200301
Issued	00562800000300
Issued	00558200000700
Closed	00568800300401
Issued	29061600400400
Issued	29052600204400
Issued	29052600102500
Issued	29062600200300
Issued	29053500401700
Closed	29060400200500
Issued	00765600000900
Closed	28060300400200
Issued	28060600300900
Issued	28070500200400
Issued	28070500200400
Issued	28060500100800
Closed	28050100202200
Closed	28060200101400
Issued	00703000004000
Issued	00761200000400
Closed	28061500102700
Issued	28061500301100
Issued	28061600400300
Issued	28070700400600
Issued	28072700202100
Issued	28072900200700
Closed	28062400100300
Issued	28062500102500
Issued	28073500204900
Issued	28043400201300
Closed	28073400300300
Closed	28073200100900
Closed	00383600004400
Closed	28073600300300
Issued	00532100004400
Issued	00617300300201
Closed	00631900002101
Closed	00631900002800
Closed	00631900002900
Issued	00623700007500
Closed	00422800003300
Issued	00460100003700

Accessory Dwelling Units

Index # - File Name: 1.0022 - Single Family Dwellings Data\_Snohomish County.pdf

Closed	00452600102200
Issued	00389400100402
Closed	00403900023701
Closed	00403900022500
Issued	00403800005901
Closed	00403800014302
Closed	27062100402000
Closed	27062200402000
Closed	27052400402600
Closed	27063200201000
Issued	27063200301600
Closed	27063400401300
Issued	27063500201900
Issued	27071900102800
Closed	27051500400900
Closed	27061600301700
Issued	27070500200300
Closed	30052400101600
Issued	00394405400401
Closed	29063200201500
Closed	31042000101100
Issued	30040800300900
Issued	29051400403300
Closed	30072900202500
Closed	29060900306000
Closed	00960002501200
Closed	00960002501701
Closed	00960002501800
Closed	00960002502602
Closed	00960002502702
Closed	00960002503700
Closed	29060200401200
Closed	29062200401500
Closed	31052400101600
Closed	27063200100600
Closed	28072100200600
Closed	31061600300200
Closed	27050900105600
Closed	00403800011201
Closed	31041800403900
Issued	31033600400100
Issued	00597600000206
Closed	00960010611100
Closed	00960010613200
Issued	00960010603700
Closed	00960010603900
Closed	00960010606000





Accessory Dwelling Units

Index # - File Name: 1.0022 - Single Family Dwellings Data\_Snohomish County.pdf

Issued	00373300500503
Issued	00373300500503
Issued	00373300500503
Issued	00373300500503
Closed	01164600000600
Closed	01164600000700
Issued	01163600001800
Issued	01163600001900
Issued	01163600002000
Closed	01163100000100
Closed	01163600001100
Closed	01163600001200
Issued	01163600001300
Closed	01165600000200
Issued	00590700007500
Issued	00591200200501
Issued	00591200200501
Issued	00509300003500
Issued	00509300003500
Issued	00509300003500
Issued	00509300003500
Issued	00509300003500
Closed	00509300003500
Issued	00509300003500
Issued	00509300003500
Issued	00509300003500
Issued	00509300003500
Issued	00554300003001
Closed	30072000201600
Closed	01152100003500
Issued	01152100001600
Closed	01152100001700
Closed	01152100000700
Closed	01152100000900
Closed	01152100001000
Closed	01152100001100
Closed	01152100001200
Closed	01152100001300
Issued	01152100001400
Closed	01152100000400
Closed	01152100000500
Closed	27071200300900
Issued	30060100302400
Closed	31043600300400
Closed	31043500403300
Closed	31043500400200
Issued	31043600300200
Issued	30040100100800

Accessory Dwelling Units

Index # - File Name: 1.0022 - Single Family Dwellings Data\_Snohomish County.pdf

Issued	01143500001300
Issued	01143500001400
Issued	01143500000200
Issued	01143500000400
Issued	00394401400004
Issued	01114100001500
Closed	01114100001600
Issued	01114100001800
Issued	01114100001900
Issued	32042200104000
Closed	00373701500400
Closed	00373701500400
Closed	00373701500400
Closed	00373701500400
Closed	00373701500400
Closed	27071400101100
Closed	00585200003402
Closed	00585200003302
Closed	00585200005302
Closed	28053300303600
Closed	28053300303700
Closed	00695400000300
Closed	00695400000300
Closed	00695400000300
Closed	00695400000300
Closed	00695400000300
Closed	00695400000300
Closed	00695400000300
Closed	00695400000300
Closed	00473200000100
Closed	00473200000100
Closed	00473200000100
Closed	01187800000200
Closed	01187800000300
Closed	01187800000400
Closed	01187800000500
Closed	01187800000600
Closed	01187800000700
Closed	01187800000800
Closed	01187800000900
Closed	01187800001000
Closed	01187800001100
Closed	01187800001800
Closed	01187800001900
Closed	28053300303100
Closed	28053300303200
Closed	28053300303300
Closed	28053300303400

Accessory Dwelling Units

Index # - File Name: 1.0022 - Single Family Dwellings Data\_Snohomish County.pdf

Issued	30050100402700
Closed	01189800000100
Closed	01189800000200
Closed	01189800000300
Closed	01189800000600
Closed	01189800001200
Closed	01189800001500
Closed	01189800001600
Closed	00373701700407
Closed	00373701700407
Closed	00373701700407
Closed	00373701700407
Closed	00373701700407
Closed	00373701700407
Closed	00373701700407
Closed	00373701700407
Closed	00373701700407
Closed	00373701700407
Closed	00373701700407
Closed	00373701700407
Closed	00373701700407
Closed	00373701700407
Closed	00373701700407
Closed	00373701700407
Closed	00373701700407
Closed	00373701700407
Closed	00585200005301
Closed	01183400000100
Closed	01183400002900
Closed	01183400003000
Closed	01183400003100
Closed	01183400003200
Closed	01183400003300
Closed	01183400003400
Closed	01183400003500
Closed	01183400003600
Closed	01183400003700
Closed	01184900001200
Closed	01184900001300
Closed	01184900001400
Closed	01184900001500
Closed	01184900001600
Closed	01184900001900
Closed	01184900002000
Closed	01184900002100
Closed	01184900002200
Closed	01184900002300
Closed	01184900002400
Closed	01184900002500
Closed	01184900002600

Accessory Dwelling Units

Index # - File Name: 1.0022 - Single Family Dwellings Data\_Snohomish County.pdf

Closed	01184900002700
Closed	01184900002800
Closed	01184900002900
Closed	01184900000100
Closed	01184900000200
Closed	01184900000400
Closed	01184900000600
Issued	27060500102400
Closed	27071100401400
Closed	31042700401300
Closed	28052700102100
Closed	28052700102100
Closed	00577700602000
Closed	01182000000100
Closed	01182000000200
Closed	01182000000300
Closed	01182000000400
Closed	01182000000500
Closed	01182000000600
Closed	01182000000700
Closed	01182000000800
Closed	01182000000900
Closed	01182000001000
Closed	01182000001100
Closed	01182000001200
Closed	01182000001300
Closed	01182000001400
Closed	01182000001500
Closed	01182000001600
Closed	01182000001700
Closed	01182000001800
Closed	01182000001900
Closed	01182000002000
Closed	01182000002100
Closed	01182000002200
Closed	01182000002300
Closed	01182000002400
Closed	01182000002500
Closed	01182000002600
Closed	01182000002700
Closed	01182000002800
Closed	01182000002900
Closed	01182000003000
Closed	01182200000100
Closed	01182200000200
Closed	01182200000300
Closed	01182200000400

Accessory Dwelling Units

Index # - File Name: 1.0022 - Single Family Dwellings Data\_Snohomish County.pdf

Closed	01182200000500
Closed	01182200000600
Closed	01182200000700
Issued	01181000003200
Closed	01181000003300
Closed	01181000003400
Closed	01181000003500
Closed	00373300200500
Closed	00373300200500
Closed	00373300200500
Closed	00373300200500
Closed	00373300200500
Closed	00373300200500
Closed	00373300200500
Closed	00373300200500
Closed	00373300200500
Closed	00373300200500
Closed	00373300200500
Closed	00373300200500
Closed	32042400402000
Closed	01181000000800
Closed	01181000000900
Closed	01181000001000
Closed	01181000001100
Closed	01181000001200
Closed	01181000001300
Closed	01181000001400
Closed	01181000001500
Closed	01181000001600
Closed	01181000001700
Closed	01181000001800
Closed	01181000001900
Closed	01181000002000
Closed	01181000002100
Closed	01181000002200
Issued	01183400004200
Issued	01183400004300
Issued	01183400000200
Issued	01183400000300
Issued	01183400000400
Closed	01183400000500
Closed	01183400000600
Closed	01183400000700
Closed	01183400001300
Closed	01183400001400
Closed	01183400001500
Closed	01183400001600
Closed	01183400001700
Issued	01183400001800



Accessory Dwelling Units

Index # - File Name: 1.0022 - Single Family Dwellings Data\_Snohomish County.pdf

Closed	00373300200500
Closed	00373300200500
Closed	01180600002200
Closed	01180600002300
Closed	01180600002500
Issued	27090800400300
Closed	01180600000600
Closed	01180600000900
Closed	01180600001000
Closed	01180600001100
Closed	01180600001200
Closed	01180600001300
Closed	01180600001400
Closed	01180600001500
Closed	01180600001600
Closed	01180600001700
Issued	28061000103100
Issued	29071800200300
Closed	00604100000808
Closed	00373002100103
Closed	00373002100103
Closed	00373002100103
Closed	00373002100103
Closed	00373002100103
Closed	00373002100103
Closed	00373002100103
Closed	00373002100103
Closed	00373002100103
Closed	00373002100103
Closed	00373002100103
Closed	00373002100103
Closed	00373002100103
Closed	00373002100103
Closed	00373002100103
Closed	00373002100103
Closed	00373002100103
Closed	00373002100103
Closed	00373002100103
Closed	00373002100103
Closed	00373002100103
Closed	00373002100103
Closed	00373002100103
Closed	00373002100103
Closed	00373002100103
Closed	00373002100103
Closed	00373002100103
Closed	00373002100103
Closed	00373002100103
Closed	00373002100103
Closed	00373002100103
Closed	00373002100103
Closed	00373002100103
Closed	00373002100103
Closed	00373002100103
Issued	00373002100103
Closed	28052800102400
Closed	28052800103100
Closed	28052800102500
Closed	28052800102600





Accessory Dwelling Units

Index # - File Name: 1.0022 - Single Family Dwellings Data\_Snohomish County.pdf

Issued	32042900401400
Issued	00597600001200
Closed	01173300004600
Closed	01173300004700
Closed	32042500202700
Closed	00604100001002
Closed	00512200000900
Issued	00492300000100
Closed	01172800000100
Issued	01172800000200
Closed	32042500200600
Issued	01168300000800
Issued	32041500101300
Closed	30062300103000
Closed	28062300401000
Closed	28062300403300
Closed	00373000301002
Issued	00532100002602
Closed	32081200301200
Closed	32081200301000
Issued	00532100002604
Issued	30070600301400
Closed	01172800000700
Closed	01172800000800
Closed	01172800000900
Closed	01172800002900
Closed	00585200003501
Closed	01174600004000
Closed	01174600004100
Closed	01174600004200
Closed	01175700004800
Closed	01175700004900
Closed	00585200004601
Closed	01174600000100
Closed	01174600000200
Closed	01174600000300
Closed	01174600000400
Closed	01174600000600
Issued	32051800102800
Issued	32051800102900
Closed	01173300004200
Closed	01173300004300
Closed	01173300004400
Issued	01173300004000
Issued	01173300003300
Closed	01181900000400
Closed	01181900000500



Accessory Dwelling Units

Index # - File Name: 1.0022 - Single Family Dwellings Data\_Snohomish County.pdf

Closed	00570300202400
Closed	00570300202400
Closed	00570300202400
Closed	00570300202400
Closed	00570300202400
Closed	01185700000100
Closed	01185700000200
Closed	01185700000400
Closed	01185700000500
Closed	01185700000600
Closed	01185700000700
Closed	01185700000800
Closed	01185700000900
Closed	01185700001000
Closed	01185700001100
Closed	01185700001200
Closed	01185700001300
Closed	01185700001400
Closed	01185700001500
Closed	01185700001600
Closed	01185700001700
Closed	01185700001800
Issued	00579200000704
Closed	28050300400600
Closed	31062900101100
Closed	31062900101200
Closed	27052800402700
Closed	27052800402700
Closed	27052800402700
Closed	27052800402700
Closed	27052800402700
Closed	27052800402700
Closed	27052800402700
Closed	27052800402700
Closed	27052800402700
Closed	27052800402700
Closed	00473200000200
Closed	00473200000200
Closed	00473200000200
Closed	00473200000200
Issued	31040400403500
Issued	00509400002300
Issued	00509400002300
Issued	00494600201006
Issued	00473200000100
Closed	01191700000200
Closed	01191700000300
Closed	01191700000400

Accessory Dwelling Units

Index # - File Name: 1.0022 - Single Family Dwellings Data\_Snohomish County.pdf

Closed	01191700000500
Issued	00538000004701
Closed	00538000004701
Closed	00538000004701
Closed	00538000004701
Closed	00538000004701
Closed	00538000004701
Closed	00538000004701
Issued	00538000004701
Closed	00538000004701
Closed	00538000004701
Closed	00538000004701
Closed	00538000004701
Closed	00538000004701
Closed	00538000004701
Closed	00538000004701
Closed	00538000004701
Closed	00538000004701
Issued	00538000004701
Closed	00538000004701
Closed	00538000004701
Issued	00538000004701
Closed	00538000004701
Closed	00538000004701
Closed	00538000004701
Closed	00538000004701
Closed	00538000004701
Closed	00538000004701
Closed	00538000004701
Closed	00538000004701
Closed	00538000004701
Issued	00505100001603
Closed	27051400104300
Closed	27051400104300
Closed	01191700000700
Closed	01191700000800
Closed	01191700000900
Closed	01191700001200
Closed	00483000005100
Closed	27063200201300
Closed	01199000000700
Closed	01192800000100
Closed	01192800000200
Closed	01192800000300
Closed	01192800000400
Issued	01192800000500
Closed	01192800000600
Closed	01192800000700
Closed	01192800000800
Closed	01192800000900
Closed	01192800001000

Accessory Dwelling Units

Index # - File Name: 1.0022 - Single Family Dwellings Data\_Snohomish County.pdf

Closed	01192800001100
Closed	01192800001200
Closed	01192800001300
Closed	00642800000100
Closed	00642800000100
Closed	00642800000100
Closed	00642800000100
Closed	00642800000100
Closed	00642800000100
Closed	00642800000100
Closed	00642800000100
Closed	00642800000100
Closed	00642800000100
Closed	01183900000300
Closed	01183900000400
Closed	01183900000500
Closed	01183900000600
Closed	01183900000700
Closed	01183900000800
Closed	01183900000900
Issued	01183900001300
Closed	01183900001500
Issued	00376800003700
Closed	00374600000204
Closed	00374600000204
Issued	00374600000204
Closed	00374600000204
Closed	00374600000204
Closed	00374600000204
Closed	00374600000204
Closed	00374600000204
Closed	00374600000204
Closed	00374600000204
Closed	00374600000204
Closed	00374600000204
Closed	00374600000204
Closed	00374600000204
Closed	00374600000204
Closed	00374600000204
Closed	00374600000204
Closed	00374600000204
Closed	00374600000204
Issued	00374600000204
Closed	00374600000204
Issued	00374600000204
Closed	00374600000204
Issued	27061800101600
Closed	00373300601800
Closed	00373300601800
Closed	00373300601800
Closed	00373300601800



Accessory Dwelling Units

Index # - File Name: 1.0022 - Single Family Dwellings Data\_Snohomish County.pdf

Closed	00373300601800
Closed	00373300601800
Issued	00373300601800
Closed	00373300601800
Closed	00373300601800
Closed	00373300601800
Issued	01188400001400
Issued	01188400001500
Issued	01188400004800
Closed	01188400004900
Closed	00601600000900
Closed	00601600001100
Closed	01190500000100
Closed	01190500000200
Closed	01190500000300
Closed	01190500000400
Closed	01190500000500
Closed	01190500000600
Closed	01190500000700
Closed	01190500000800
Closed	01190500000900
Closed	01190500001000
Closed	01190500001100
Closed	01190500001200
Closed	01190500001300
Closed	01190500001400
Closed	01190500001500
Closed	01190500001600
Closed	01190500001700
Closed	01190500001800
Closed	01190500001900
Closed	01190500002000
Closed	01190500002100
Closed	01190500002200
Closed	01190500004100
Closed	01190500004200
Closed	01190500004300
Issued	01190500004400
Closed	01190500004500
Closed	01190500004600
Closed	01188400002400
Issued	01190500002700
Closed	01190500002800
Closed	01190500002900
Closed	01190500003000
Closed	01190500003100
Closed	01190500003200

Accessory Dwelling Units

Index # - File Name: 1.0022 - Single Family Dwellings Data\_Snohomish County.pdf

Closed	01190500003300
Closed	01190500003400
Closed	01190500003500
Closed	01190500003600
Closed	01190500003700
Closed	01190500003800
Closed	01190500003900
Closed	01188400004300
Closed	01188400004500
Issued	01188400004600
Closed	01190500008000
Closed	01190500008100
Closed	01190500008200
Closed	01190500008300
Closed	01190500008400
Issued	32053400102100
Issued	00555300400504
Closed	00555300400504
Closed	00555300400504
Issued	30051400201700
Issued	32042700402500
Closed	00373002100502
Closed	00373002100502
Issued	00373002100502
Issued	00373002100502
Issued	00373002100502
Closed	00373002100502
Closed	00373002100502
Closed	00373002100502
Closed	00586900000202
Closed	00586900000202
Closed	00586900000202
Closed	00586900000202
Closed	00586900000202
Closed	00586900000202
Closed	00586900000202
Closed	00586900000202
Closed	00586900000202
Closed	00586900000202
Issued	00374700001801
Issued	00374700001801
Issued	00374700001801
Issued	00374800005501
Issued	00373700300409
Closed	01191800001100
Closed	01191800001200
Closed	01191800001300
Closed	01191800001400



Accessory Dwelling Units

Index # - File Name: 1.0022 - Single Family Dwellings Data\_Snohomish County.pdf

Closed	01191800001500
Closed	01191800001700
Closed	01191800001800
Closed	01191800001900
Closed	01191800002200
Closed	01191800002600
Closed	01191800003300
Closed	01191800003400
Issued	00374700001801
Closed	00374700001801
Closed	00374700001801
Issued	00374700001801
Closed	00373700200300
Closed	00373700200300
Closed	00373700200300
Closed	00373700200300
Closed	01193400000200
Closed	01193400000500
Closed	01193400000600
Closed	01193400001300
Closed	01193400001400
Closed	01193400001600
Closed	01193400001700
Closed	01193400001800
Closed	00373701500400
Closed	00373701500400
Closed	00373701500400
Closed	00373701500400
Closed	01190300000200
Closed	01190300000300
Closed	01190300000400
Issued	31061800300900
Closed	01190300001000
Closed	01190300001100
Closed	00695400001300
Closed	00695400001300
Closed	00695400001300
Closed	00695400001300
Closed	28083000402700
Closed	01194300002100
Closed	01194700001000
Closed	01194700001100
Closed	01194700001200
Closed	01194700001300
Closed	01194400001200
Closed	01194400001300
Issued	01199900001300

Accessory Dwelling Units

Index # - File Name: 1.0022 - Single Family Dwellings Data\_Snohomish County.pdf

Issued	01199900001400
Issued	01199900001600
Closed	01199900001700
Issued	31052700401400
Closed	01194700000200
Issued	01199900000400
Issued	01199900000500
Closed	00373701500400
Closed	01199900000100
Issued	01199900000200
Closed	32041800304700
Issued	01199900000300
Closed	01190300000100
Issued	01199900000600
Issued	01199900000700
Issued	01199900000900
Issued	01199900001000
Issued	01199900001100
Issued	01199900001200
Closed	01194700000300
Closed	01194700000400
Issued	01194700000500
Issued	01194700000600
Issued	01194700000700
Issued	01194700000800
Issued	01194700000900
Issued	32042400400200
Issued	32042400400200
Issued	32042400400200
Issued	32042400400200
Issued	28072500401400
Issued	30040100201100
Issued	01196600000800
Issued	01196600000900
Issued	01196600001000
Issued	01196600001100
Issued	01196600001200
Issued	01196600001300
Issued	01196600001400
Issued	01198400000900
Issued	01198400001000
Issued	01198400001100
Issued	01198400001200
Issued	01198400001600
Issued	01198400002100
Issued	01198400002200
Issued	01198400002600

Accessory Dwelling Units

Index # - File Name: 1.0022 - Single Family Dwellings Data\_Snohomish County.pdf

Issued	01198400002700
Issued	01198400003200
Issued	01198400003300
Issued	01198400003400
Issued	01198400003500
Issued	01198400003600
Issued	01198400003700
Issued	01198400003800
Issued	00494600202208
Issued	31040500100100
Issued	28072100201200
Issued	30060600200300
Issued	00509300001001
Issued	00509300001001
Issued	00509300001001
Issued	00509300001001
Issued	00509300001001
Issued	00509300001001
Issued	00630000001000
Issued	00630000001000
Issued	00630000001000
Issued	00630000001000
Issued	00630000001000
Issued	00630000001000
Issued	27052100305000
Issued	27052100305000
Issued	27052100305000
Issued	00373000301805
Issued	01193900000100
Issued	01193900000200
Issued	01193900000300
Issued	01193900000400
Issued	01193900000500
Issued	01193900000600
Issued	01193900000800
Issued	01193900000900
Issued	01193900001000
Issued	01193900001100
Issued	01193900001200
Issued	01193900001400
Issued	01193900001500
Issued	01193900001700
Issued	01193900001800
Issued	01193900001900
Issued	01193900002000
Issued	01193900002100
Issued	01193600000200

Accessory Dwelling Units

Index # - File Name: 1.0022 - Single Family Dwellings Data\_Snohomish County.pdf

Issued	01193600000300
Issued	01193600000400
Issued	01193600000500
Issued	01193600000600
Issued	01193600000700
Issued	01193600000800
Issued	01193600000900
Issued	01193600001000
Issued	29063400100200
Closed	00480401803400
Issued	00562800004200
Issued	00562800004200
Issued	00562800004200
Issued	00562800004200
Issued	00562800004200
Issued	00562800004200
Issued	00562800004200
Issued	00562800004200
Issued	00373000301002
Issued	00372800601400
Issued	00372800601400
Issued	00372800601400
Issued	00372800601400
Issued	00372800601400
Issued	00372800601400
Issued	00372800601400
Issued	00372800601400
Issued	00372800601400
Issued	00372800601400
Issued	00372800601400
Issued	00512000210400
Issued	01196200000100
Issued	01196200000200
Issued	01196200000300
Issued	01196200000400
Issued	01196200000700
Issued	01196200000800
Issued	01196200001100
Issued	01196200001200
Issued	00513700004301
Issued	00513700004301
Issued	00513700004301
Issued	00513700004301
Issued	00513700004301
Issued	00373700701100
Issued	00459700100201
Issued	00459700100201
Issued	00493900007900

Accessory Dwelling Units

Index # - File Name: 1.0022 - Single Family Dwellings Data\_Snohomish County.pdf

Issued	00493900007900
Issued	00493900007900
Issued	00493900007900
Issued	00493900007900
Issued	00493900007900
Issued	00493900007900
Issued	00493900007900
Issued	00493900007900
Issued	00493900007900
Issued	00493900007900
Issued	00493900007900
Issued	00493900007900
Issued	00493900007900
Issued	00493900007900
Issued	00493900007900
Issued	00493900007900
Issued	00493900007900
Issued	00493900007900
Issued	00493900007900
Issued	00493900007900
Issued	00493900007900
Issued	00493900007900
Issued	01192200001300
Issued	01192200001400
Issued	01192200001500
Issued	01192200001600
Issued	01192200001700
Issued	01192200001800
Issued	01192300000100
Issued	01192300000800
Issued	01192300001100
Issued	32041500401100
Issued	00473300001602
Issued	30051200103100
Closed	01194400001400
Closed	01194400001500
Closed	01194400002000
Closed	01194400002100
Issued	01194400002200
Issued	29061200301700
Issued	31052700401500
Issued	01199800000800
Issued	01199800000900
Issued	01199800001000
Issued	01199800001100
Issued	01199800001200
Issued	01199800001300
Issued	01199800001400

Accessory Dwelling Units

Index # - File Name: 1.0022 - Single Family Dwellings Data\_Snohomish County.pdf

Issued	01199800001500
Issued	01199800001600
Issued	01199800001700
Issued	01199800001800
Issued	01199800001900
Issued	01199800002100
Issued	01199800002200
Issued	01194700001500
Issued	01194300000100
Issued	01194300000200
Closed	01194300000300
Closed	01194300000400
Closed	01194300000500
Closed	01194300000600
Closed	01194300001300
Closed	01194300001400
Closed	01194300001500
Closed	01194300001600
Closed	01194300001700
Issued	01194300001800
Issued	01194300001900
Issued	01194300002000
Issued	01194300002200
Issued	01194600000300
Issued	01194600000400
Issued	01194600000500
Issued	01194600000600
Issued	01194600000700
Issued	01194600000800
Issued	01194600000900
Issued	01194600001000
Issued	01194600001100
Issued	01194600001200
Issued	01194600001300
Issued	01194600001400
Issued	01194600001500
Issued	01194600001600
Issued	01194600001700
Issued	01194600001800
Issued	01194600001900
Issued	01194600002000
Issued	01194600002100
Issued	01194600002200
Issued	01194600002300
Issued	01194600002400
Issued	01194600002500
Issued	01194600000100

Accessory Dwelling Units

Index # - File Name: 1.0022 - Single Family Dwellings Data\_Snohomish County.pdf

Issued	01194600000200
Closed	01194400000100
Issued	01194400000600
Issued	01194400000700
Issued	01194400000800
Issued	01194400000900
Issued	01194400001000
Issued	00372900600807
Issued	01197400001000
Issued	01197400001100
Issued	00542000001200
Issued	00542000001200
Issued	00542000001200
Issued	00542000001200
Issued	01194700000100
Issued	01190300001400
Issued	01190300001500
Closed	00695400001300
Issued	00585200005303
Issued	29061400202400
Issued	31050400203100
Issued	29062200300500
Issued	00394404607201
Issued	29061500303600
Issued	01190300000500
Issued	01190300000600
Closed	01190300000700
Issued	01190300000800
Issued	01190300000900
Closed	00373701500400
Issued	00373701500400
Issued	00373701500400
Issued	00373701500400
Issued	00373701500400
Closed	01193400000700
Closed	01193400000800
Issued	01193400000900
Issued	01193400001000
Closed	01193400001100
Issued	01193400001200
Issued	00374700001801
Issued	01191800003500
Issued	01191800003600
Closed	01191800002300
Issued	01191800002400
Issued	01191800002500
Closed	01191800002000

Accessory Dwelling Units

Index # - File Name: 1.0022 - Single Family Dwellings Data\_Snohomish County.pdf

Closed	01191800002100
Issued	01191800001600
Issued	00504500400301
Issued	00504500400302
Issued	00504500400602
Issued	00504500401100
Issued	00374700001801
Issued	00374700001801
Issued	00374700001801
Issued	00374700001801
Issued	00374700001801
Issued	00374700001801
Issued	00374700001801
Issued	00374700001801
Issued	00374700001801
Issued	00374700001801
Issued	00374700001801
Issued	00374700001801
Issued	00374700001801
Issued	00374700001801
Issued	00374700001801
Issued	00374700001801
Issued	00374700001801
Issued	00374700001801
Closed	00512000206300
Issued	01191800000100
Issued	01191800000200
Issued	01191800000300
Issued	01191800000400
Issued	01191800000500
Issued	01191800000600
Issued	01191800000700
Issued	01191800000800
Issued	01191800000900
Closed	01191800001000
Issued	01190500008500
Issued	01190500008600
Issued	01188400004700
Issued	01188400004400
Issued	01190500004000
Issued	01188400002500
Issued	01188400002600
Issued	01188400002900
Issued	01188400003000
Issued	01188400003100
Issued	01188400003200
Issued	01188400003500
Issued	01188400003600



Accessory Dwelling Units

Index # - File Name: 1.0022 - Single Family Dwellings Data\_Snohomish County.pdf

Issued	01188400003800
Issued	01188400004100
Issued	01188400004200
Closed	01190500004700
Closed	01190500004800
Issued	01190500004900
Issued	01190500005000
Issued	01190500005100
Issued	01190500005200
Issued	01190500005300
Issued	01190500005400
Issued	01190500005500
Issued	01190500005600
Issued	01190500005700
Issued	01190500005800
Issued	01190500005900
Issued	01190500006000
Issued	01190500006100
Issued	01190500006200
Issued	01190500006300
Issued	01190500006400
Issued	01190500006500
Issued	01190500006600
Issued	01190500006700
Issued	01190500006800
Issued	01190500006900
Issued	01190500007000
Issued	01190500007100
Issued	01190500007200
Issued	01190500007300
Issued	01190500007400
Issued	01190500007500
Issued	01190500007600
Issued	01190500007700
Issued	01190500007800
Issued	01190500007900
Issued	01190500002300
Issued	01190500002400
Issued	01190500002500
Issued	01190500002600
Issued	01188400001600
Issued	01188400001700
Issued	01188400001800
Issued	01188400002000
Issued	29053600102800
Issued	01188400000400
Issued	01188400000600

Accessory Dwelling Units

Index # - File Name: 1.0022 - Single Family Dwellings Data\_Snohomish County.pdf

Issued	01188400001300
Issued	00394403201100
Closed	00373300601800
Issued	00373300601800
Issued	00373300601800
Issued	28061100103800
Issued	28061100103700
Issued	27051100201400
Issued	00543800001501
Issued	00394402401601
Issued	00394402402001
Closed	00373300601800
Closed	00373300601800
Issued	00373300601800
Issued	00373300601800
Issued	00373300601800
Issued	00373300601800
Issued	00373300601800
Issued	00374600000204
Issued	01183900001600
Issued	01183900001700
Issued	01183900000100
Issued	01183900000200
Issued	00394401601600
Issued	29051100400400
Issued	29051100400400
Issued	01191700001000
Issued	01191700001100
Issued	01199000000100
Closed	01191700000600
Issued	00473200000100
Issued	31042100300400
Issued	01191700000100
Issued	00538000004701
Issued	01173300004500
Issued	32051800103000
Issued	00585200002701
Issued	00394402401000
Issued	00394402401400
Issued	00394402504800
Issued	00394402506001
Issued	00394402506801
Issued	32041500101500
Issued	01173300004800
Issued	00492300000100
Issued	00375000002500
Issued	31061900301000

Accessory Dwelling Units

Index # - File Name: 1.0022 - Single Family Dwellings Data\_Snohomish County.pdf

Issued	27062200401100
Issued	32063200403800
Issued	01176600000400
Issued	01176600000500
Issued	01176600000600
Issued	01176600000700
Issued	00570600202200
Issued	00570600202200
Issued	00570600202200
Issued	00570600202200
Issued	00570600202200
Issued	01180600000100
Closed	01180600000200
Issued	01180600000300
Issued	01180600000400
Issued	01180600000500
Issued	01180600002100
Issued	32042100302700
Issued	00373300200500
Issued	00373300200500
Issued	00373300200500
Issued	00373300200500
Issued	00451700000900
Issued	00585200002101
Issued	32081200200600
Issued	00585200001901
Issued	00585200002001
Issued	00585200002702
Issued	00585200002901
Issued	00585200003101
Closed	01183400003800
Issued	00394402401801
Issued	00394402401201
Issued	00394402402201
Issued	00394402506401
Closed	28053300303500
Issued	00473200000100
Issued	00494600201009
Issued	00494600201008
Issued	00494600201007
Issued	00373300200500
Issued	00373701500400
Issued	00373701500400
Issued	00585200003001
Issued	32052100300600
Issued	30060600203300
Issued	32051900300200

Accessory Dwelling Units

Index # - File Name: 1.0022 - Single Family Dwellings Data\_Snohomish County.pdf

Issued	31040500301400
Issued	01152100001500
Issued	32091700100400
Issued	28072100200100
Issued	32062800100500
Issued	27071100301300
Issued	32063400303800
Issued	30062300103000
Issued	01164600000400
Issued	01166400001600
Issued	00373300500503
Issued	00614800002100
Issued	01157800000100
Issued	01157800000300
Issued	01157800000600
Issued	01157800000700
Issued	01157800000800
Issued	01157800000900
Issued	32061600400800
Issued	01109500000900
Issued	01109500003000
Closed	01109500003100
Closed	01109500003200
Closed	01109500003300
Issued	01109500003400
Issued	01109500003500
Issued	01109500003600
Issued	00512000203700
Issued	27051500302100
Issued	01053400001500
Issued	31041700200400
Issued	00494600201107
Issued	30051200100900
Issued	01068500000300
Issued	01068500000400
Issued	00960010601100
Issued	00960010603000
Issued	29073000200500
Issued	29073000200500
Issued	29073000200600
Issued	29073000200600
Closed	00960012900800
Issued	31051300100800
Issued	29061000401800
Issued	27070100301300
Issued	00403800000906
Issued	32060900401300

Accessory Dwelling Units

Index # - File Name: 1.0022 - Single Family Dwellings Data\_Snohomish County.pdf

Issued	30072000203200
Issued	30060500403400
Issued	31060400203500
Issued	00960002504300
Issued	00960002501700
Issued	28072100201800
Issued	27051100307100
Issued	32063300303600
Issued	29053600101700
Issued	00960002500501
Issued	00494600300607
Issued	32043600300100
Issued	32043600100600
Issued	00401000011200
Issued	27070100100900
Issued	27061600300500
Issued	27061800400100
Issued	00372900600703
Issued	27062200402100
Issued	00403800005902
Issued	00403800002000
Issued	00376800004901
Issued	00623700003800
Issued	00630000001000
Issued	00609600001500
Closed	00512200003000
Issued	00509200100900
Issued	28073600300700
Issued	00373300900603
Issued	00375000006501
Issued	28063300101200
Issued	28052800203800
Issued	28072800400300
Issued	28071800401300
Issued	28071800300900
Closed	00700400013100
Issued	28060200200600
Issued	28060200200600
Issued	28060300403500
Issued	28060400101400
Issued	00623600003100
Issued	29062300401200
Issued	29062100100100
Issued	00436200000500
Issued	00420600000100
Issued	00574000007100
Issued	30072000202100

Accessory Dwelling Units

Index # - File Name: 1.0022 - Single Family Dwellings Data\_Snohomish County.pdf

Issued	30061800301700
Issued	30052000301500
Issued	00397700002700
Issued	00457100001200
Issued	00533400002102
Closed	00516700011300
Closed	00625600000700
Issued	30040200102200
Issued	00627100000200
Issued	00627100000300
Issued	00548200002205
Issued	30063100400800
Issued	30063600300200
Issued	31040800100200
Issued	31031300102000
Issued	31042600402000
Issued	31041700201000
Closed	31052600101400
Issued	00394510600800
Issued	00394402300900
Issued	32042400101800
Issued	32053000100600
Issued	32043200202600
Issued	32073000401400
Closed	32051300300300
Issued	00537400001300
Issued	00494600300606
Issued	28072600202700
Issued	32053300402700
Issued	00394405100600
Issued	30040200300900
Issued	29061500101400
Issued	27051100306700
Issued	31040800300300
Issued	30062400301800
Closed	30062500201700
Issued	00383800000300
Issued	00490100002800
Issued	29060400404000
Issued	32051800201200



## Accessory Dwelling Units

This page provides a brief overview of accessory dwelling units for cities and counties in Washington State, including legal requirements and examples of city and county codes.

---

### What is an Accessory Dwelling Unit?

An accessory dwelling unit (ADU) is a small, self-contained residential unit located on the same lot as an existing single-family home.

An ADU has all the basic facilities needed for day-to-day living independent of the main home, such as a kitchen, sleeping area, and a bathroom. As the term "accessory" implies, ADUs are generally defined to be smaller in size and prominence than the main residence on the lot. Some definitions include specific size limits, and a location that is not readily visible from the street.

In theory, an ADU may be created as a separate unit within an existing home (such as in an attic or basement), an addition to the home (such as a separate apartment unit with separate entrance), or in a separate structure on the lot (such as a converted garage). See the examples shown below.

Some communities, however, only allow ADUs that are within or attached to the main residence, and exclude ADUs housed in a separate structure. Whether attached or detached from the main residence, most codes require that the main residence and the ADU must be owned by the same person and may not be sold separately.

ADUs are sometimes called "mother-in-law apartments" or "granny flats," because they are often used to house extended family. Other codes use terms such as "accessory apartment," "accessory living unit," or "secondary unit," to have a similar meaning.

## Accessory Dwelling Units

Index # - File Name: 1.0023 - MRSC\_Accessory Dwelling Unit Guide.pdf

## Examples of Accessory Dwelling Units (ADUs)

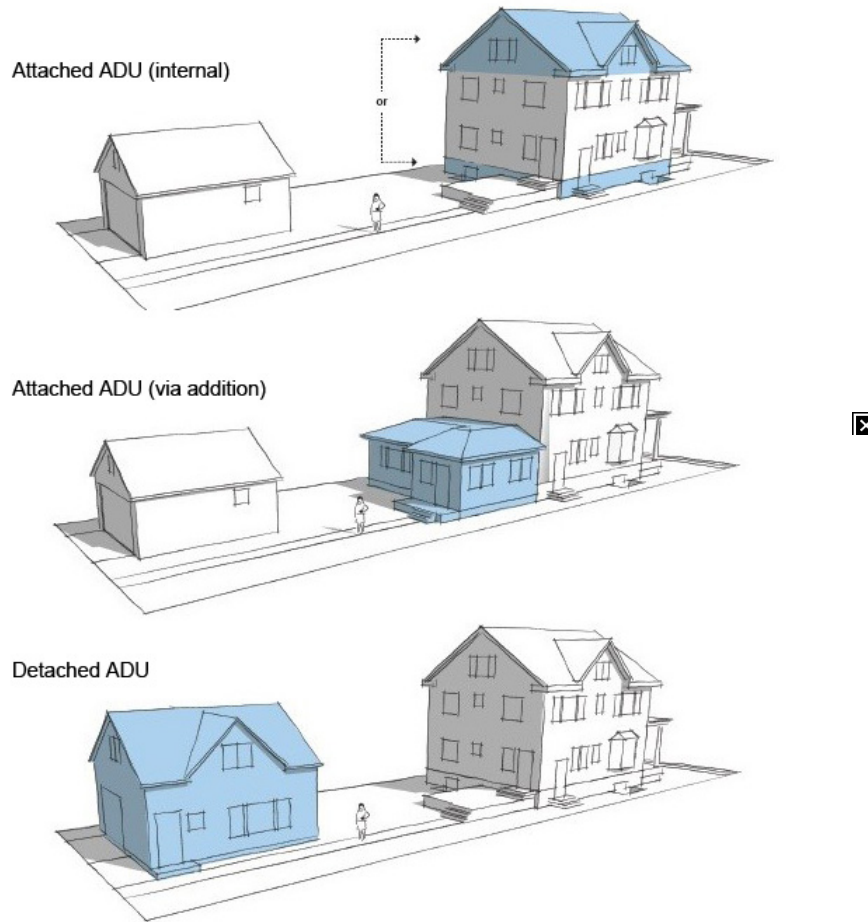
*ADUs in blue; main residence in white*

## Accessory Dwelling Units in Washington State

[RCW 43.63A.215](#) and [RCW 36.70A.400](#), adopted as part of the 1993 Washington Housing Policy Act, require many Washington cities and counties to adopt ordinances encouraging the development of accessory apartments or ADUs in single-family zones. Specifically, this legislation applies to:

- Cities with a population over 20,000
- Counties with a population over 125,000
- Counties that plan under the Growth Management Act (GMA).

Other communities may choose to allow ADUs if so desired.

Local codes must incorporate the [model ordinance recommendations](#) prepared by the Washington State Department of Community, Trade and Economic Development (now Department of Commerce), per [RCW 43.63A.215](#) and [RCW 36.70A.400](#). However, state law allows local communities some flexibility to adapt these recommendations to local needs and preferences.



## Accessory Dwelling Units

Index # - File Name: 1.0023 - MRSC\_Accessory Dwelling Unit Guide.pdf

ADU ordinances have been widely adopted in Washington since the 1993 Act, in part because ADUs have helped local jurisdictions meet GMA goals to encourage affordable housing and provide a variety of housing densities and types while preserving the character of single-family neighborhoods.

## Examples of Local ADU Codes

The table below provides examples of accessory dwelling unit codes adopted by cities and counties in Washington State, including a basic comparison of their provisions. (Click on the image to see a larger version.)

Most of these examples allow for both attached ADUs (sometimes called AADUs) and detached ADUs (sometimes called DADUs). With the exception of Vancouver, each requires that one of the units be occupied by the owner of the property. Many of the provisions limit the size of the accessory unit, ranging from 600 to 1,000 square feet. Some also limit the size of the accessory unit relative to the primary unit, ranging from 40 to 75 percent of the area of the primary unit.

Almost all of the code provisions rely on the development regulations of the underlying zones. Several provide maximum heights, onsite-parking, setbacks and other requirements specific to ADUs. Additionally, many of code provisions require the ADU to be similar in design to the primary unit (which may or may not be desirable, depending upon the design of the primary residence).

## Washington Examples

Click on the table below to view a summary analysis of selected ADU provisions from cities in Washington State, including links to the actual code provisions.

City	Attached or Detached?	Owner-Occupancy required?	Lot Size	Unit Size	Parking	ADU specific requirements	Code Provisions
<a href="#">Bellevue</a>	Attached only	Yes	Not specified	Between 300 and 800 sf, not to exceed 40% of the combined area of the ADU and primary unit	1 space	Limited number of occupants	<a href="#">Sec. 20.20.120</a>
<a href="#">Bellingham*</a>	Both	Yes	Alley access, side street access, or greater than 5,000 sf	Limited to 800 sf or 66% of primary structure, and two bedrooms	1 space	Setback and minimum yard	<a href="#">Draft ADU Ordinance (2018)</a> <a href="#">Webpage about ADU Ordinance Update Process</a>
<a href="#">Blaine</a>	Both	Yes	At least 6,000 sf	Varies based on lot size, 600-1,000 sf or 50% of primary residence	1 space for each bedroom	Max height, design bonus	<a href="#">Ch. 17.102</a>
<a href="#">Cheney</a>	Both	Yes	Greater than 5,000 sf	Limited to 40% of area of primary units livable area, cannot be more than one bedroom	If on-street parking is available: None. If no on-street parking: 1 space	Max height	<a href="#">Ch. 21.67</a>
<a href="#">Enumclaw</a>	Both	Yes	No limit	Limited to 800 sf and two bedrooms, or 50% of livable area of primary unit	Not specified		<a href="#">Ch. 19.34</a>
<a href="#">Everett</a>	Both	Yes	None	Limited to 800 sf or 75% of the gross floor area of the primary unit	1 space, can be waived if there is sufficient on-street parking or public transit access	Max height, setbacks	<a href="#">Ch. 19.07.030</a>
<a href="#">Seattle*</a>	Both	Yes	For DADUs at least 4,000 sf	AADU: limited to 1,000 sf for single-family structure and 650 sf for townhome; DADU: limited to 800 sf for single-family structure and 650 sf for townhomes	1 space, can be waived in urban villages/centers	Max height, entrance location	<a href="#">Sec. 23.44.041</a> <a href="#">Webpage about ADU EIS Process</a>
<a href="#">Vancouver</a>	Both	No	At least 4,500 sf	Limited to 800 sf or up to 50% of the size of the primary unit, except for basement suites	None		<a href="#">Ch. 20.810</a>

[Click for larger version](#)

## Out-of-State Examples

- [Portland, OR: Accessory Dwelling Units](#) – Information on Portland's successful program including code links and [ADU Program Guide](#)
- [Santa Cruz, CA: Accessory Dwelling Unit Development Program](#) – Program assists homeowners seeking to build an ADU, including prototype concepts and a [step-by-step guide](#) on how to plan, design, and obtain permits for an ADU
- [Vancouver, BC: Building your laneway house](#) – Provides prospective ADU builders with a [“how-to” guide](#), examples floor plans, and other resources for their project

## Emerging Trends

A few Washington State cities, such as Seattle, are re-examining some of the standards listed above to determine if they are acting as barriers to the construction of new ADUs (see [Seattle study process](#)). One of the alternatives being examined by Seattle's study is streamlining permitting by providing pre-approved ADU plans.

As may be seen in the out-of-state examples above, some cities such as Portland (OR), Santa Cruz (CA), and Vancouver (BC) have actually changed some of their requirements, such as eliminating owner occupancy, in order to encourage the production of more ADUs. Vancouver has also had success getting banks to provide [lending products](#) tailored to ADU projects that take into account the borrowers' future rental income from the new unit. Portland also provides an [ADU Financing Guide](#) that identifies local financial institutions with programs that can be used to fund ADU construction.

The preliminary results appear to show that the reduced zoning requirements have resulted in more ADUs in these cities. For example, since adopting its ADU program in 2009, Vancouver has permitted over 3,000 ADUs and has set the target of adding another 4,000 by 2028. Recent regulatory reform, fee waivers, and public education efforts in Portland have contributed to the doubling of the number of annual ADUs permits, from under 300 in 2014 to over 600 in 2016.

---

## Recommended Resources

- [Seattle Planning Commission: A Guide to Building Backyard Cottages](#) (2010) – Detailed guidance for building detached ADUs in Seattle
- [Urban Land Institute: Jumpstarting the Market for Accessory Dwelling Units: Lessons Learned from Portland, Seattle, and Vancouver](#) (2018) – Study examining best practices from Portland, Seattle, and Vancouver BC
- [AccessoryDwellings.org](#) – Portland, OR-based website maintained by volunteers provides current ADU news, articles, project examples, and other resources, including a [Model Code for Accessory Dwelling Units](#)
- [Oregon Department of Environmental Quality: Accessory Dwelling Unit Survey for Portland, Eugene, and Ashland](#) (2013) – Includes data on ADU use, occupancy, construction, energy use, and demographics
- [MRSC: Accessory Dwelling Units Issues and Options](#) (1995) – Detailed publication created after the 1993 Washington Housing Policy Act discusses benefits, regulatory issues, and zoning regulations for ADUs.

Last Modified: January 08, 2019

## Examples of Local Accessory Dwelling Unit (ADU) Codes in Washington State

City	Attached or Detached?	Owner-Occupancy required?	Lot Size	Unit Size	Parking	ADU specific requirements	Code Provisions
Bellevue	Attached only	Yes	Not specified	Between 300 and 800 sf, not to exceed 40% of the combined area of the ADU and primary unit	1 space	Limited number of occupants	<a href="#">Sec. 20.20.120</a>
Bellingham*	Both	Yes	Alley access, side street access, or greater than 5,000 sf	Limited to 800 sf or 66% of primary structure, and two bedrooms	1 space	Setback and minimum yard	<a href="#">Draft ADU Ordinance (2018)</a> <a href="#">Webpage about ADU Ordinance Update Process</a>
Blaine	Both	Yes	At least 6,000 sf	Varies based on lot size, 600-1000 sf or 50% of primary residence	1 space for each bedroom	Max height, design bonus	<a href="#">Ch. 17.102</a>
Cheney	Both	Yes	Greater than 5,000 sf	Limited to 40% of area of primary units livable area, cannot be more than one bedroom	If on-street parking is available: None. If no on-street parking: 1 space	Max height	<a href="#">Ch. 21.67</a>
Enumclaw	Both	Yes	No limit	Limited to 800 sf and two bedrooms, or 50% of livable area of primary unit	Not specified		<a href="#">Ch. 19.34</a>
Everett	Both	Yes	None	Limited to 800 sf or 75% of the gross floor area of the primary unit	1 space, can be waived if there is sufficient on-street parking or public transit access	Max height, setbacks	<a href="#">Ch. 19.07.030</a>
Seattle*	Both	Yes	For DADUs at least 4,000 sf	AADU: limited to 1,000 sf for single-family structure and 650 sf for townhome; DADU: limited to 800 sf for single-family structure and 650 sf for townhomes	1 space, can be waived in urban villages/centers	Max height, entrance location	<a href="#">Sec. 23.44.041</a> <a href="#">Webpage about ADU EIS Process</a>
Vancouver	Both	No	At least 4,500 sf	Limited to 800 sf or up to 50% of the size of the primary unit, except for basement suites	None		<a href="#">Ch. 20.810</a>

\*Jurisdiction is in process of updating or evaluating its ADU ordinances

# QUICKNOTES

## Accessory Dwelling Units

Accessory dwelling units (ADUs) are small, self-contained living units that typically have their own kitchen, bedroom(s), and bathroom space. Often called granny flats, elder cottage housing opportunities (ECHO), mother-daughter residences, or secondary dwelling units, ADUs are apartments that can be located within the walls of an existing or newly constructed single-family home or can be an addition to an existing home. They can also be freestanding cottages on the same lot as the principal dwelling unit or a conversion of a garage or barn.

The benefits to the home owner and the ADU occupant are many. For the home owner, ADUs provide the opportunity to offer an affordable and independent housing option to the owner's grown son or daughter just starting out or to an elderly parent or two who might need a helping hand nearby. The unit could also be leased to unrelated individuals or newly established families, which would provide the dual benefit of providing affordable housing to the ADU occupant and supplemental rental income to the owner. Supplemental income could offset the high cost of a home mortgage, utilities, and real estate taxes. Finally, leasing an ADU to a young person or family can provide an elderly home owner with a sense of security and an opportunity to exchange needed work around the house and yard for a discount on rent.

Despite the benefits, some communities resist allowing ADUs, or allow them only after time-consuming and costly review procedures and requirements. Public resistance to ADUs usually takes the form of a perceived concern that they might transform the character of the neighborhood, increase density, add to traffic, make parking on the street more difficult, increase school enrollment, and put additional pressure on fire and police service, parks, or water and wastewater. However, communities that have allowed ADUs find that these perceived fears are mostly unfounded or overstated when ADUs are actually built.

ADUs are a particularly desirable option for many communities today considering the current economic climate, changes in household size, increasing numbers of aging baby boomers, and the shortage of affordable housing choices. They provide a low-impact way for a community to expand its range of housing choices.

### LOCALITIES AND STATES GET INTO THE ACT

Towns, cities, and counties across the country have done the right thing by proactively amending local zoning ordinances to allow ADUs. This is typically done either as a matter of right or as a special or conditional use. In either case, reasonable conditions may be imposed. Some states, including California, have enacted legislation that limits the ability of localities to zone out ADUs.

In 2001 AARP retained APA's Research Department to write a guidance report for citizens interested in convincing local and state officials of the benefits of allowing ADUs and showing them how to do it. *Entitled Accessory Dwelling Units: Model State Act and Model Local Ordinance*, the monograph provides alternative statute and ordinance language useful to implementing all forms of ADUs.

*The Model Local Ordinance* suggests recommendations for communities. Additionally, the intent of the ordinance describes the permitting process for eligibility and approval, and further outlines standards for ADU approval pertaining to lot size, occupancy, building standards, parking and traffic, public health, and how to deal with nonconforming ADUs. *The Model State Act* provides findings and policies encouraging the approval of ADUs and names local governments as the entities entitled to authorize

"Towns, cities, and  
counties across the  
country have done  
the right thing by  
proactively  
amending local  
zoning ordinances  
to allow ADUs."



**American Planning Association**

*Making Great Communities Happen*

adoption of an ADU statute. It specifies the limits to which local governments may prohibit ADUs and outlines default permitting provisions if a locality does not adopt an ADU ordinance. It details optional approaches for adopting ADU ordinances, certifying local ADU ordinances, gathering data on ADU efforts, preparing reports and recommendations, and forming a statewide board overseeing ADUs.

### WHAT ISSUES ARISE WHEN A PROPOSED ADU ORDINANCE IS CONSIDERED?

ADU ordinances offer a variety of benefits to local communities but the road to implementation may not be an easy process. While ADUs are more widely accepted now than in years past, skeptics still remain and some still oppose ADU zoning. The following describes some issues or decision points that communities must address in order to successfully navigate the perilous waters of public acceptance. The approach that is right for your city or town will be unique, based on local physical, political, social, and economic conditions.

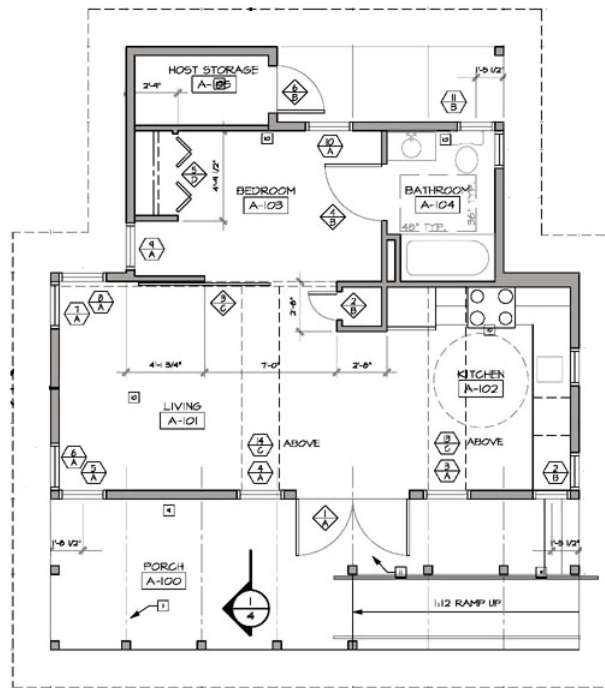

Single story ADU floor plan.

David Baker and Partners Architects

**By-right Permitting.** Should permits for ADUs be issued as a matter of right (with clear standards built into the ordinance) or should they be allowed by discretion as a special or conditional use after a public hearing?

**Occupancy.** Should ordinance language allow an ADU only on the condition that the owner of the property lives in one of the units?

**Form of Ownership.** Should the ordinance prohibit converting the ADU unit into a condominium?

**Preexisting, nonconforming ADUs.** How should the ordinance treat grandfathered ADUs? How do you treat illegal apartments that want to apply for an ADU permit?

**Unit Size:** Should the ordinance limit the square footage of the ADU to assure that the unit is truly accessory to the principal dwelling on the property?

**Adequacy of Water and Sewer Services.** How do you guarantee there is enough capacity in sewer lines, pumping stations, and treatment facilities to accommodate ADUs?

These are not easy issues. However, communities would do well to seriously consider adopting an approach that: allows ADUs by right with clear written conditions; does not require owner occupancy; prohibits condominium ownership on the basis that a condo could not be considered accessory; provides a simple procedure for legalizing preexisting or formerly illegal apartments provided the unit is inspected; provides a generous size standard; and provides a water and sewer adequacy standard. □

*PAS QuickNotes is a publication of the American Planning Association's Planning Advisory Service (PAS). Copyright © 2009. Visit PAS online at [www.planning.org/pas](http://www.planning.org/pas) to find out how PAS can work for you. American Planning Association staff: W. Paul Farmer, FAICP, Executive Director and CEO; William R. Klein, AICP, Director of Research and Advisory Services; Tre Jerdon, QuickNotes Editor; Tim Mennel, Senior Editor; Julie Von Bergen, Assistant Editor; Susan Deegan, Senior Graphic Designer.*

For a complete list of references visit <http://www.planning.org/pas/quicknotes/>

## REFERENCES

### 1. Published by American Planning Association

American Planning Association. "Affordable Housing Reader: Articles from Zoning News and Zoning Practice. Available at <http://myapa.planning.org/affordablereader> (members-only access).

American Planning Association. 2006. *Policy Guide on Housing*. Chicago: American Planning Association. Available at [www.planning.org/policy/guides/pdf/housing.pdf](http://www.planning.org/policy/guides/pdf/housing.pdf).

Baggett, Sharon, Nancy Chapman, and Deborah Howe. 1994. *Planning for an Aging Society*. Planning Advisory Service Report no. 451. Chicago: American Planning Association.

For more information on this topic visit [www.planning.org](http://www.planning.org).

# QUICKNOTES

## References: Accessory Dwelling Units

### 1. Published by American Planning Association

American Planning Association. "Affordable Housing Reader: Articles from Zoning News and Zoning Practice. Available at <http://myapa.planning.org/affordablereader> (members-only access).

American Planning Association. 2006. *Policy Guide on Housing*. Chicago: American Planning Association. Available at [www.planning.org/policy/guides/pdf/housing.pdf](http://www.planning.org/policy/guides/pdf/housing.pdf).

Baggett, Sharon, Nancy Chapman, and Deborah Howe. 1994. *Planning for an Aging Society*. Planning Advisory Service Report no. 451. Chicago: American Planning Association.

Baron Pollak, Patricia. 1994. "Rethinking Zoning to Accommodate the Elderly in Single Family Housing." *Journal of the American Planning Association* 60 (4): 521–531.

Gorman, Alice, and Patricia Pollak. 1989. *Community-Based Housing for the Elderly*. Planning Advisory Service Report no. 420. Chicago: American Planning Association.

Howe, Deborah A. 1990. "The Flexible House Designing for Changing Needs." *Journal of the American Planning Association* 56 (1): 69–77.

Lubell, Jeffrey. 2006. "Zoning to Expand Affordable Housing." *Zoning Practice*. December. Chicago: American Planning Association.

Meyerson, Deborah. 2007. "The Ultimate in Accessibility." *Planning*, December, 44–45.

Wittenberg, Jason. 2002. "Garages: Not Just for Cars Anymore." *Zoning News*. August. Chicago: American Planning Association.

### 2. Other Resources

Center for Housing Policy. 2008. Ensuring Zoning Policies Allow Housing Diversity: Accessory Dwelling Units. Available at [www.housingpolicy.org/toolbox/strategy/policies/diverse\\_housing\\_types.html?tierid=42](http://www.housingpolicy.org/toolbox/strategy/policies/diverse_housing_types.html?tierid=42).

Cobb, Rodney, and Scott Dvorak. 2000. *Accessory Dwelling Units: Model State Act and Local Ordinance*. Washington, D.C.: AARP. Available at [http://assets.aarp.org/rgcenter/consume/d17158\\_dwell.pdf](http://assets.aarp.org/rgcenter/consume/d17158_dwell.pdf).

Cram, Leo. 1993. Missouri Gerontology Institute. "Accessory Apartments." University of Missouri Extension. Available at <http://extension.missouri.edu/explore/aging/gg0014.htm>.

Massachusetts Executive Office of the Environment. (N.d.) *Model Bylaw for Accessory Dwelling Units*. Massachusetts Smart Growth Toolkit Bylaw. Available at [www.mass.gov/envir/smart\\_growth\\_toolkit/bylaws/ADU-Bylaw.pdf](http://www.mass.gov/envir/smart_growth_toolkit/bylaws/ADU-Bylaw.pdf).

Minnetonka (Minnesota), City of. *A Citizen's Guide to Accessory Apartments*. Available at [www.eminnetonka.com/community\\_development/planning/brochures/accessory\\_apartments.pdf](http://www.eminnetonka.com/community_development/planning/brochures/accessory_apartments.pdf)

Municipal Research and Services Center of Washington. 1995. *Accessory Dwelling Units*. Report No. 33. Seattle: Municipal Research and Services Center of Washington. Available at [www.mrsc.org/Publications/adu30.pdf](http://www.mrsc.org/Publications/adu30.pdf).

Phillips, Jory. 2004. *Detached Accessory Dwelling Units*: Director's Report. Seattle: City of Seattle Department of Planning and Development. Available at [www.mrsc.org/GovDocs/s42ADUrpt.pdf](http://www.mrsc.org/GovDocs/s42ADUrpt.pdf).

Portland (Oregon), City of. 2006. *Planning and Zoning Code*. Chapter 33.205. Accessory Dwelling Units. Available at [www.portlandonline.com/auditor/index.cfm?a=53301&c=28197](http://www.portlandonline.com/auditor/index.cfm?a=53301&c=28197). Also see [www.portlandonline.com/bds/index.cfm?c=dgghg](http://www.portlandonline.com/bds/index.cfm?c=dgghg).

Provo (Utah), City of. 2007. Zoning Code. Section 14.46.A. *Accessory Apartment Overlay Zone*. Available at [www.provo.org/downloads/council/title\\_14\\_chapters\\_41-49c\\_combined.pdf](http://www.provo.org/downloads/council/title_14_chapters_41-49c_combined.pdf).

Santa Cruz (California), City of. 2003. *Accessory Dwelling Unit Manual*. Available at [www.ci.santa-cruz.ca.us/pl/hcd/ADU/PDF/ADU\\_Manual.pdf](http://www.ci.santa-cruz.ca.us/pl/hcd/ADU/PDF/ADU_Manual.pdf).

U.S. Department of Housing and Urban Development. 2004. "Accessory Housing is Part of the Solution." Available at [www.huduser.org/rbc/newsletter/vol3iss1more.html](http://www.huduser.org/rbc/newsletter/vol3iss1more.html)



**American Planning Association**

*Making Great Communities Happen*

# QUICKNOTES

## 3. Case Law

*Anderson v. Provo City Corp.*, 2005 UT 5 (2005).

*City of Wilmington v. Hill*, 657 S.E.2d 670 (2008).

*Coalition Advocating Legal Housing Options v. City of Santa Monica*, 88 Cal.App.4th 451 (2001).

*Desmond v. County of Contra Costa*, 21 Cal.App.4th 330 (1993).

*Harris v. City of Costa Mesa*, 25 Cal.App.4th 963 (1994).

*Kasper v. Town of Brookhaven*, 142. A.D.2d 213 (1988).

*Save Round Valley Alliance v. County of Inyo*, 157 Cal. App. 4th 1437 (2007).

*Sounhein v. City of San Dimas*, 47 Cal.App. 4th 1181 (1996).

*Village of Belle Terre v. Boraas*, 416 U.S. 1 (1976).

1 BEFORE THE WESTERN WASHINGTON GROWTH MANAGEMENT HEARINGS BOARD

2  
3 FRIENDS OF SAN JUANS, LYNN BAHRYCH and JOE  
4 SYMONS,

5 Petitioners,

6 v.

7  
8 SAN JUAN COUNTY,

9 Respondent.

No. 03-2-0003c

**COMPLIANCE ORDER**

10  
11 JAMES NELSON, ET AL

12 Petitioners,

13 v.

14 SAN JUAN COUNTY,

15 Respondent.

Case No. 06-2-0024c

**FINAL DECISION AND ORDER**

16  
17  
18  
19 **I. SYNOPSIS**

20 San Juan County is an exceptionally beautiful rural county made up of islands with magnificent  
21 vistas and miles of shoreline. The County is accessible only by ferry or air. Most of its land is  
22 devoted to rural or resource uses. These unique characteristics have long made it a destination for  
23 tourists and a location for seasonal second homes. For almost a decade, the County has struggled  
24 with how to provide detached accessory dwelling units (ADU)<sup>1</sup> that are used as a source of income  
25 for residents, accommodations for guest and caretakers, and as a source of affordable housing.  
26 The length of this decision reflects the length of the struggle. During this time the Board of County  
27 Commissioners form of government has been changed to a County Council, and the membership of  
28 San Juan County's legislative body has changed as well.  
29  
30  
31

32 <sup>1</sup> The descriptor for these units has also evolved over time from guesthouse to freestanding ADU to now detached ADU.



1 The Friends of San Juan County (Friends) have long opposed the unrestricted allowance of  
2 detached ADUs in rural and resource lands and have challenged the County's previous attempts to  
3 adopt regulations to allow them. In our 2003 Final Decision and Order, we agreed with Friends that  
4 unrestricted numbers of detached ADUs in rural and resource lands created sprawl and urban  
5 growth in those areas, and violated the underlying residential densities. Now Friends supports the  
6 County's latest effort at amending its regulations for detached ADUs established by Ordinance 7-  
7 2006 (the Ordinance), amending SJCC 18.40.240 and other provisions of the County Code.  
8 However, Ordinance 7-2006 has not settled the controversy, and nine petitions challenged this  
9 ordinance.

10  
11 In April 2003 the Board found noncompliant the County's regulations for detached ADUs (then called  
12 freestanding ADUs) because they did not count a 1000 square foot detached ADU as a unit of  
13 density in rural and resource lands, in violation of RCW 36.70A.060(1), RCW 36.70A.070(5), RCW  
14 36.70A.110. The Board further found that the continued validity of those regulations for detached  
15 ADUs in rural and resource lands substantially interfered with the fulfillment of Goals 2 and 8 of the  
16 Growth Management Act (GMA) (RCW 36.70A. 020(2) and (8)).<sup>2</sup>

17  
18 To remedy these noncompliance and invalidity findings, the County adopted amendments to its  
19 regulations for detached ADUs. First, the new ADU regulations provide that a detached ADU is  
20 considered as a separate residential unit for purposes of calculating residential density. This  
21 amendment conforms to the Board's determination that a detached ADU should be counted as an  
22 additional residence for purposes of calculating density. Second, the regulations create a program  
23 for permitting a small number of detached ADUs in rural and resource lands in excess of the  
24 underlying zoning density annually. Under the permitting program, a small number of detached ADU  
25 permits will be issued with strict limitations on location, shared utilities, size, ownership, and impacts  
26 on open space features of the property. The purpose of these restrictions is to ensure that the new  
27 ADUs are accessory to the primary residence and do not negatively impact the rural character of the  
28 Islands or the use of designated resource lands for agriculture or timber production. The County  
29  
30

31  
32 <sup>2</sup> The Board rescinded invalidity placed on the County's provisions regulating detached ADUs in Order Lifting  
Invalidity issued on August 18, 2006 based on the amendments adopted by Ordinance 7-2006

1 projects that the number of rural and resource detached ADUs will not come to more than 15  
2 annually.

3  
4 In this decision, the Board considers whether this permitting program disturbs the densities of  
5 existing compliant rural areas, creates urban growth in those areas or encourages sprawl. In rural  
6 lands, the Board finds that the small number of detached ADU permits issued annually under the  
7 conditions placed on them will not disturb the existing compliant scheme of rural densities. The  
8 Board determines that because of the limitations described in the regulations and the historical  
9 pattern of guesthouses, permitting a small number of such detached ADUs in rural lands will not  
10 upset the traditional rural pattern of development in San Juan County and will not alter its rural  
11 character. As a consequence, we also find that this limited exception to counting detached ADUs  
12 as additional residential density does not allow urban growth in rural areas (RCW 36.70A.110(1)),  
13 nor does it promote sprawl (RCW 36.70A.020(2)).  
14

15  
16 However, we find that where the regulations permit detached ADUs on substandard rural lots (of 1 to  
17 4 acres) they establish non-rural densities, creating urban growth and promoting sprawl. SJCC  
18 18.40.240(G)(4) allows detached ADUs on rural lots that are already of non-rural densities. By  
19 allowing additional residences on those lots, that regulation contributes to even more intense uses  
20 on nonconforming rural lots. With a second residence on a small rural lot, the regulations allow  
21 residential uses to predominate over rural uses and rural levels of development. We find that this  
22 amendment (SJCC 18.40.240(G)(4)) is not compliant with the County's own comprehensive plan  
23 and the definitions of rural uses and rural development in the GMA. Further, the intensive residential  
24 uses on substandard rural lots constitute urban growth in rural lands in violation of RCW  
25 36.70A0110(1).  
26

27 The problem of pre-existing substandard lots is not prevalent in designated resource lands.  
28 However, the question in those lands is not so much one of compliant densities as one of  
29 conservation of those lands for purposes of resource production. In resource lands, the Board finds  
30 the size and location requirements will ensure that permitted detached ADUs do not convert  
31 agricultural or timber land to other uses or create uses on resource lands that are incompatible with  
32 the production of agriculture or timber. Further, the small number of ADU permits issued annually

1 will be spread out over both rural and resource lands resulting in very few detached ADUs in  
2 resource lands.

3 Petitioners also challenge the public participation program followed by the County to adopt  
4 Ordinance 7-2006. Petitioners challenge that the process was flawed, in part because the County  
5 entered into settlement discussions with Friends which formed the basis for the first draft of the  
6 Ordinance. Petitioners believe that public input was disregarded as a result.

7  
8 Here, we find that the public process followed by the County in adopting Ordinance 7-2006 was well  
9 publicized and extensive. While Friends made recommendations for the new ADU regulations, there  
10 was extensive opportunity for the public as a whole to comment on proposals and to make their own  
11 suggestions. Changes made to the draft ordinance over the course of the public process reflect  
12 consideration of comments and alternative points of view.

13  
14 Petitioners also argue that the changes to the ADU regulations exceeded the scope of the remand  
15 from this Board and therefore should have been considered in the regular comprehensive plan  
16 amendment cycle. In this regard, the Board finds that the County had discretion to address the  
17 subject of the remand - regulation of ADUs – to resolve the appeal to the Board pursuant to RCW  
18 36.70A.130(2)(b) and 36.70A.140 and chose to do so in the approach adopted in Ordinance 7-2006;  
19 the County did not go beyond the scope of the remand such that it was required to adopt the  
20 amendments to its ADU ordinance in its annual amendment cycle.

21  
22  
23 Petitioners assert a number of other challenges to the compliance of Ordinance 7-2006 with the  
24 GMA. They also argue that Ordinance 7-2006 fails to comply with the State Environmental Policy  
25 Act (SEPA) (Ch. 43.21C RCW), and the Shoreline Management Act (SMA) (Ch. 90.58 RCW), as  
26 well as claiming that the County's requirement for one ERU per detached ADU violates the County  
27 comprehensive plan, its development code, and state law. Several Petitioners also contend that the  
28 Ordinance places limitations on the construction or conversion of ADUs that are too restrictive,  
29 hinder the development of affordable housing, and interfere with economic development. One  
30 Petitioner claims that the permitting process created under the Ordinance is inefficient and unfair.  
31 The Board finds that Petitioners have not met their burden of proof that any of these violations have  
32 occurred here. Further, the Board notes that the County strategy as to ADUs harmonizes the

1 Housing (Goal 4), Economic Development (Goal 5), and Permitting (Goal 7) goals of the Act with the  
2 Sprawl Reduction (Goal 2) and Natural Resource Industries (Goal 8).

3 **II. PROCEDURAL HISTORY**

4 See Appendix A.

6 **III. ISSUES TO BE DISCUSSED**

7 **COMPLIANCE ISSUE (CASE NO. 03-2-0003c)**

8 Does the action that the County has taken to achieve compliance with the Board's April 17, 2003  
9 Final Decision and Order/Compliance Order that found the County's regulations that allow for a  
10 freestanding accessory dwelling unit (ADU) on single-family lots with a principal residence in rural  
11 lands and resource lands, without counting it as a unit of density for the purpose of calculating the  
12 underlying density, cause the County's regulations for regulating freestanding accessory dwelling  
13 units to no longer substantially interfere with the goals of the Growth Management Act and to comply  
14 with the goals and requirements of the Growth Management Act. See Corrected Final Decision and  
15 Order (April 17, 2003)?<sup>3</sup>

15 **ISSUES IN CASE NO. 06-2-0024c**

16 **SPRAWL**

17 Issue 1: Does Ordinance 7-2006, Section 18.40.240 G(1)(b) fail to comply with Growth Board  
18 orders dated April 17, 2003 and July 21, 2005 and RCW 36.70A.020(2) and (8) by allowing  
19 freestanding ADUs in rural and resource lands subject to an annual quota system? (Manning et al.,  
20 06-15c, Nelson, 06-20, and Wanda Evans, 06-17)

21 Issue 2: Is Ordinance No 7-2006, Section 18.40.240 A – G noncompliant with RCW 36.70A.020,  
22 Planning Goals 1 and 2, by allowing densities of greater than one unit per five acres in rural lands  
23 and Goal 4, by increasing land values in rural lands? (Ludwig, 06-24)

23 **AFFORDABLE HOUSING**

24 Issue 3: Does the Ordinance 7-2006, Sections 18.40.240 A, C, G (1), G(4)(b), and G(4c) fail to  
25 encourage the availability of affordable housing to all economic segments of the population, promote  
26 a variety of residential densities and housing types, and encourage affordable housing in violation of  
27 RCW 36.70A.020(4)? (Manning et al., 06-15C)

28 Issue 4: Does the Ordinance 7-2006, Sections 6,7, 8, and 9 fail to encourage the availability of  
29 affordable housing to all economic segments of the population in violation of RCW 36.70A.020(4)  
30 and RCW 36.70A.540? (Gutschmidt, 06-20)

31 <sup>3</sup> This description of the April 19, 2003 Final Decision and Order reflects the January 9, 2004, Thurston  
32 County Superior Court decision that upheld the Board in regard to density requirements for accessory dwelling  
units in resource and rural lands, but overturned the Board's decision on requirements for location and  
occupancy requirements in resource lands.

1  
2 Issue 5: Does Ordinance 7-2006, Section 8, SJCC 18.40.270 C violate RCW 36.70A.011 by not  
3 allowing short-term rentals? (Wanda Evans, 06-17)

4 **PROPERTY RIGHTS**

5 Issue 6: Does the Ordinance 7-2006 as a whole fail to ensure that private property shall not be  
6 taken from public use without just compensation having been made and that the property rights of  
7 landowners shall be protected from arbitrary and discriminatory actions in violation of RCW  
8 36.70A.020(6)? (Manning et al., 06-15c)

9 **PERMITTING**

10 Issue 7: Does Ordinance 7-2006, Section 18.40.240 G(1)(b) and Sections 1, 3, 5 fail to further the  
11 goal of having applications for permits processed in a timely and fair manner to ensure predictability  
12 in violation of RCW 36.70A.020(7)? (Gutschmidt, 06-20, Manning et al., 06-15c)

13 **CITIZEN PARTICIPATION AND COORDINATION**

14 Issue 8: Did the County fail to develop Ordinance 7-2006 by not involving citizens in the planning  
15 process and ensuring coordination between communities and jurisdictions to reconcile conflicts as  
16 required by RCW 36.70A.020(11)? (Manning et al., 06-15c)

17 Issue 9: Did San Juan County violate the public participation requirements of RCW 36.70A. 130 and  
18 RCW 36.70A.140 by entering into the non-public development of a ‘Settlement Agreement’ with the  
19 Friends of the San Juans, and then enacting the substance of that Agreement against the advice  
20 from the Planning Commission and the Prosecuting Attorney, and without considering the potential  
21 improvements to the settlement draft that were offered by Petitioners and other public participants?  
22 (Baldwin et al., 06-16, Wiese 06-19)

23 Issue 10: Did the County’s actions in adopting Ordinance 7-2006 violate RCW 36.70A.  
24 035(2)(a)(ii)? (John Evans, 06-18, Wanda Evans, 06-17, Wiese 06-19)

25 Issue 11: Did the Ordinance 7-2006 violate RCW 36.70A. 035(1) (c) by not notifying Class A and  
26 Class B water systems of the legislation affecting private water systems established by Ordinance 7-  
27 2006? (Wanda Evans, 06-17)

28 Issue 12: Did Ordinance 07-2006 violate the San Juan County Code, by inserting “Lot Coverage”  
29 legislation in an ordinance that is advertised as an Accessory Dwelling Unit Ordinance without  
30 proper public process and without using the annual docket process? (Wanda Evans, 06-17)

31 Issue 13 : Did the County fail to use good faith to ensure public participation and consider public  
32 input in developing Ordinance 7-2006 in violation of RCW 36.70A.020(11) and RCW 36.70A.140?  
(Gutschmidt, 06-20)

Issue 14: Does the requirement for one equivalent residential unit (ERU) of water for any detached  
ADU contained on Ordinance 7-2006, Section 9, mislead the public process and is it contrary to the  
County’s stated goals, as stated in the Ordinance’s recitals, in violation of RCW 36.70A.020 (4) and  
(7), RCW 36.70A.540, and RCW 36.70A.011? (Gutschmidt, 06-20)

1 Issue 15: Does Ordinance 7-2006 violate the GMA public process requirements contained in RCW  
2 36.70A.130(2)(a) which allow amendments “no more frequently than once per year”? (Nelson, 6-20,  
3 Manning et al., 06-15c)

4 Issue 16: Does the public participation plan adopted for Ordinance 7-2006 comply with RCW  
5 36.70A.140 and does it substantially interfere with RCW 36.70A.020(11)? (Nelson, 06-20)

6 Issue 17: Did the “back door” negotiations with the Friends of the San Juans before and during the  
7 process that led to the adoption of Ordinance 7-2006 corrupt the public process to the point that the  
8 County failed to comply with the requirements of RCW 36.70A.020(11) and RCW 36.70A.140?  
9 (Nelson, 06-20)

10 Issue 18: Did the County’s failure to follow through with its representation to the Board that it would  
11 seek an Appeals Court decision before attempting to amend the Development Code corrupt the  
12 public process contrary to RCW 36.70A.020(11) and RCW 36.70A. 140 and therefore substantially  
13 interfere with the GMA? (Nelson, 06-20)

14 **PROCEDURAL ISSUES**

15 Issue 19: Did the County violate RCW 36.70A.106 by not properly notifying the Department of  
16 Community Trade and Economic Development of its intent to adopt Ordinance 7-2006 at least 60  
17 days prior to final adoption? (Manning et al., 06-15c)

18 Issue 20: Does Ordinance 7-2006 impermissibly address issues which were adequately addressed  
19 in the prior code provisions, and were not part of the Board’s earlier finding of noncompliance and  
20 invalidity in violation of RCW 36.70A.130 (1), (2)(a)(b) and (7)? (Baldwin et al 06-16)

21 Issue 21: Did the failure of Ordinance 7-2006 to set forth the goals and provisions of the GMA that  
22 were considered violate RCW 36.70A.130 and RCW 36.70A.140 by failing to afford the public an  
23 opportunity to comment at a public hearing on the rationale being considered? (Baldwin et al., 06-  
24 16)

25 Issue 22: Did the County violate RCW 36.70A.305, RCW 36.70A.330, and RCW 36.70A.140 by  
26 going well beyond the issues of noncompliance? (John Evans, 06-18)

27 Issue 23: Does Ordinance 7-2006 that includes provisions which were neither challenged or found  
28 by this Board to be noncompliant in the previous ordinance (21-2002), which the present Ordinance  
29 seeks to remedy, and which are unrelated to the issues of structural density, violate RCW  
30 36.70A.130(2)(b), RCW 36.70A.040, RCW 36.70A.040, and RCW 36.70A.100? (Wiese, 06-19)

31 Issue 24: Does Ordinance 7-2006 violate GMA procedural requirements contained in RCW  
32 36.70A.130 (1)(d) and (2)(a) and (b) by adopting new regulations which are unrelated to the  
compliance issues raised in the July 21, 2005 Order, and therefore should have been considered  
under the County’s annual docket process? (Nelson, 06-20)

Issue 25: Did the County’s failure to make the entire public record that was developed during the  
adoption process available by including it in the index provided to the Growth Board constitute a

1 violation of their duty to comply with RCW 36.70A.290(4) and therefore substantially interfere with  
2 RCW 36.70A.020(11). (Nelson, 06-20)

3 Issue 26: Did the County through the adoption of Ordinance 7-2006, Section 6, violate RCW  
4 36.70A.370 and RCW 36.70A.140, by failing to show in the record why 12 percent was chosen as  
5 the number of detached accessory dwelling units allowed in a given year, why there are no detached  
6 ADUs allowed on lots less than one acre, why there are no detached ADUs allowed on lots less than  
7 five acres in the shoreline, why there are limitations on proximity of ADUs to a principal residence,  
and why there is a prohibition of rentals of ADUs? (John Evans, 06-18)

8 Issue 27: Does Ordinance 7-2006 (at Sections. 6.F.3, 6.G.1.b, 6.G.2, and 8 and 9) establish new  
9 restrictions limiting construction and use of a main house after a guest house has been constructed,  
10 violate RCW 36.70A.302 (3-b-i) and substantially interfere with RCW 36.70A.020(6) and RCW  
11 36.70A.370(2) by depriving property owners who have complied with previously existing County  
12 regulations, and who have built guest houses in anticipation of later building a main dwelling, of their  
13 vested rights which were established when they lawfully secured a permit to build their guest  
house? (Wiese, 06-19)

14 **ACCESSORY DWELLING UNITS (ADUs)**

15 Issue 28: Do the restrictions placed on ADUs in rural and resource lands by Ordinance 7-2006  
16 violate 43.63A.215, as well as RCW 36.70A.020, RCW 36.70A.540, and RCW 36.70A.400 by  
17 allowing ADUs attached to the principal residence while restricting ADUs attached to either an  
otherwise allowed or existing accessory structure when neither location of an ADU contributes to  
additional structural density on rural or resource lands? (John Evans, 06-18)

18 Issue 29: Does Ordinance 7-2006, Sections 1 and 2, violate RCW 36.70A.400 and RCW  
19 43.63A.215, by limiting the permitting of detached ADUs to 12 percent of the building permits from  
20 the previous year and allowing only two percent of these permits to be conversions of existing  
21 buildings and by not allowing ADUs to be attached to a garage or other accessory building? (Wanda  
Evans, 06-18)

22 **SHORELINE MANAGEMENT ACT**

23 Issue 30: Did the passing of Ordinance 7-2006 violate the Shoreline Management Act, RCW  
24 90.58.130 and RCW 36.70A.480(1) by amending the County's Shoreline Master Program without  
25 proper notification and adoption process? (Wanda Evans, 06-17, Manning et al., 06-15c)

26 Issue 31: Did the passing of Ordinance 7-2006, Section 18.40.240 G(4)(c) violate WAC 173-26-100  
27 (1) and (2), RCW 90.58.090 because no notice was given that Ordinance 7-2006 amended  
28 Shoreline Density? (Wanda Evans, 06-17)

29 Issue 32: Did the County fail to adhere to the requirements of RCW 36.70A.480 (1) by adopting  
30 changes to the shoreline regulations in the Uniform Development Code without following the  
31 required public process and adoptions procedures and without considering the impact of the new  
32 regulations on shoreline properties and consistency with the regulations of the Shorelines Element  
of the CP? (Nelson, 6-20)

**1 STATE ENVIRONMENTAL POLICY ACT (SEPA)**

**2** Issue 33: Did the County violate SEPA, RCW 42.21C, and WAC 197-11-560 when it adopted the  
**3** Ordinance without SEPA review? (Manning et al.06-15c).

**4** Issue 34: Did the County violate WAC 197-11-230 by conducting a SEPA process for the Ordinance  
**5** that was reviewed by the Planning Commission, and by not conducting a new SEPA process for the  
**6** new ordinance that was adopted by the County Council? (John Evans, 06-17, Wanda Evans, 06-18  
**7** John Evans)

**8** Issue 35: Did the County's adoption process for Ordinance 7-2006 fail to comply with the  
**9** requirements of the SEPA and therefore violate RCW 43.21 C and WAC 197-11-080, -210, -330, -  
**10** 060, -158, -230, and -235 which requires SEPA compliance and consistency with the County's  
**11** comprehensive plan, including its Shoreline Element? (Nelson, 06-20)

**12** Issue 36: Is the SEPA Threshold Determination of DNS noncompliant with RCW 43.21C and the  
**13** SEPA Rules, Chapter 197-11-060, -080, and -330 WAC? (Ludwig, 06-24)

**14** Issue 37: Was the environmental evaluation and analysis required by the SEPA rules adequate and  
**15** compliant with RCW 43.21C and Chapter 197-11 -030 and -031 WAC? (Ludwig, 06-24)

**16 HOUSING POLICY ACT**

**17** Issue 38: Is the Ordinance consistent with the State's Housing Policy Act, RCW 43.185B.0009?  
**18** (Manning et al, 06-15c).

**19 WATER SYSTEMS**

**20** Issue 39: Does the requirement contained in Ordinance 7-2006 for one additional Equivalent  
**21** Residential Unit (ERU) of water for an detached ADU violate RCW 36.70A.130(1)(d), RCW  
**22** 36.70A.070 and 36.70A.040(5) because it is inconsistent with the goals and policies of the  
**23** Comprehensive Plan Section 4.2.B.1.6 and Development Regulations (UDC Section 18.60.020)  
**24** contrary to state policy and water regulations that are regulated by WAC 246-290-100-4 and WAC  
**25** 246-290-100-4(b)(i) and (ii)? (Nelson, 06-20, Wanda Evans, 06-17).

**26 CONSISTENCY**

**27** Issue 40: Is all or part of Ordinance 7-2006 inconsistent or internally inconsistent with elements of  
**28** the County's Comprehensive Plan and Development Code and does it therefore violate RCW  
**29** 36.70A.070, RCW 36.70A.040(4), RCW 36.70A.130(1)(a) -(d) and (2)(b), RCW 36.70A.060(3),  
**30** WAC 365-195-630 and WAC 365-195-500 which require comprehensive plans and development  
**31** regulations to be consistent and internally consistent? (Nelson, 06-20)

**32 IV. BURDEN OF PROOF**

For purposes of board review of the comprehensive plans and development regulations adopted by  
local government, the GMA establishes three major precepts: a presumption of validity; a "clearly  
erroneous" standard of review; and a requirement of deference to the decisions of local government.



1 Pursuant to RCW 36.70A.320(1), comprehensive plans, development regulations and amendments  
2 to them are presumed valid upon adoption:

3 Except as provided in subsection (5) of this section, comprehensive plans and development  
4 regulations, and amendments thereto, adopted under this chapter are presumed valid upon  
5 adoption.

6 RCW 36.70A.320(1).

7 This same presumption of validity applies when a local jurisdiction takes legislative action in  
8 response to a noncompliance finding, that legislative action is presumed valid.

9 The statute further provides that the standard of review shall be whether the challenged enactments  
10 are clearly erroneous:

11 The board shall find compliance unless it determines that the action by the state agency,  
12 county, or city is clearly erroneous in view of the entire record before the board and in light of  
13 the goals and requirements of this chapter.

14 RCW 36.70A.320(3)

15 In order to find the County's action clearly erroneous, the Board must be "left with the firm and  
16 definite conviction that a mistake has been made." *Department of Ecology v. PUD1*, 121 Wn.2d  
17 179, 201, 849 P.2d 646 (1993).

18 Within the framework of state goals and requirements, the boards must grant deference to local  
19 government in how they plan for growth:

20 In recognition of the broad range of discretion that may be exercised by counties and cities in  
21 how they plan for growth, consistent with the requirements and goals of this chapter, the  
22 legislature intends for the boards to grant deference to the counties and cities in how they plan  
23 for growth, consistent with the requirements and goals of this chapter. Local comprehensive  
24 plans and development regulations require counties and cities to balance priorities and options  
25 for action in full consideration of local circumstances. The legislature finds that while this chapter  
26 requires local planning to take place within a framework of state goals and requirements, the  
27 ultimate burden and responsibility for planning, harmonizing the planning goals of this chapter,  
28 and implementing a county's or city's future rests with that community.

29 RCW 36.70A.3201 (in part).

30 In sum, the burden is on the Petitioner to overcome the presumption of validity and demonstrate that  
31 any action taken by the County is clearly erroneous in light of the goals and requirements of Ch.  
32 36.70A RCW (the Growth Management Act). RCW 36.70A.320(2). Where not clearly erroneous  
and thus within the framework of state goals and requirements, the planning choices of local  
government must be granted deference.

**V. DISCUSSION OF COMPLIANCE ISSUE IN 03-02-0003c**

**COMPLIANCE – WWGMHB CASE NO. 03-2-0003C**

Positions of the Parties

**Participants' Positions**

Petitioners Ludwig and Austin contend that the amendments made to the County's ADU regulations by Ordinance 7-2006 still do not comply with RCW 36.70A.020(2) and RCW 36.70A.110(1) because they allow a detached ADU on less than 10 acres in rural areas.<sup>4</sup>

Petitioners Manning, Blanchard, Marshall, Baldwin, and Ziegler argue that the Ordinance allows for a detached ADU in rural and resource lands in direct contravention to the Board's April 17, 2003 order.<sup>5</sup>

Petitioner James Nelson asserts that contrary to the Board's order the County continues to allow freestanding ADUs in rural and resource lands. He says that the allowance of an unlimited but unknown number of freestanding (detached) ADUs subject to an annual quota system in Ordinance 7-2006 allows for higher than rural densities, does not conserve resource lands and does not comply with RCW 36.70A.110(1), RCW 36.70A. 070 (5)(b)(c), and RCW 36.70A.060.<sup>6</sup>

Mr. Nelson claims that these amendments attempt to cloud the distinction between a freestanding ADU and one that is attached to an outbuilding by describing freestanding ADUs now as detached. He declares that this change was made to prohibit combining a garage and an ADU in many cases, when in a number of cases property owners will be allowed a garage, a house, and an ADU. He says the approach allowed by the amendments is a greater assault on structural density than was allowed under the prior ordinance.<sup>7</sup> He claims that the ADU amendments, particularly those requiring the ADU to be within a 100 feet of the primary residence will have unintended negative

---

<sup>4</sup> Ludwig, Participants' Objections to a Finding of Compliance at 1 and 2; Austin, Participant's Objections to a Finding of Compliance at 1 and 2.

<sup>5</sup> Manning and Blanchard, Opposition to Compliance Report and Motion to Lift Invalidity Filed by San Juan County and Objection to a Finding of Compliance at 2; Marshall, Baldwin, and Ziegler, Objection to Finding of Compliance and Motion to Supplement the Record at 3.

<sup>6</sup> Nelson, Participant's Objection to a Finding of Compliance and Motion to Supplement the Record at 3, 8.

<sup>7</sup> Ibid at 7.

1 impacts on the shoreline and will cause a “cookie cutter” approach to development that does not  
2 protect the rural character of San Juan County.<sup>8</sup>

3 He claims that the Board should only find compliance if the Board reverses its April 17, 2003 order  
4 and that the County has not met its burden of proof that Ordinance 7-2006 is compliant with the  
5 Growth Board orders of April 17, 2003 and July 21, 2005.<sup>9</sup>

6  
7 **County’s Position**

8 San Juan County asks that the Board find compliance because the amendments adopted by  
9 Ordinance 7-2006 now count detached ADUs as a unit of density in rural and resource lands with a  
10 limited exception. The exception is the allowance of a small number of ADUs located in close  
11 proximity to a primary residence subject to an annual cap. That cap is 12 percent of the number of  
12 building permits for new principal residences issued for the previous year, with two of the twelve  
13 percent reserved for conversion of existing accessory buildings. The County projects that this will  
14 result in about 15 detached ADUs annually in rural and resource lands.<sup>10</sup>

15  
16  
17 The County points out that this limitation on the number of detached ADUs in rural and resource  
18 lands is combined with strict environmental and visual protections, including a sharing of utilities and  
19 driveways between the ADU and principal residence, requiring a full ERU for water, prohibition of  
20 detached ADUs in natural or conservancy lands, and required minimum lot sizes.<sup>11</sup>

21 The County maintains that detached guesthouses have been part of the historic character of the San  
22 Juan Islands and are consistent with its present rural landscape, where the natural environment  
23 predominates over the man made, and is compatible the GMA’s requirements to preserve rural  
24 character.<sup>12</sup>

25  
26 Petitioner Friends of the San Juans supports a finding of compliance because Ordinance 7-2006  
27 allows only a very limited number of detached ADUs in the manner of historic guest houses to  
28 continue being developed while tightly restricting the environmental and structural impacts of those  
29

30 <sup>8</sup> Ibid at 9 and 10.

31 <sup>9</sup> Ibid at 3 and 6.

32 <sup>10</sup> Compliance Report and Motion to Rescind Invalidity at 3-4.

<sup>11</sup> Ibid at 5.

<sup>12</sup> Ibid at 5

1 detached ADUs. Friends says that adding 15 new detached ADUs a year will have a de minimus  
2 impact on the character of the County's rural lands and the effective use of the county's resource  
3 lands.<sup>13</sup>

4  
5 Board Discussion

6 The situation presented to the Board at this time is markedly different from that presented in 2003.  
7 The chief petitioner in the underlying case, Friends of San Juans (Friends), no longer challenges the  
8 compliance of the County's ADU development regulations with the goals or requirements of the  
9 Growth Management Act (GMA). In fact, Friends now supports a finding of compliance as to the  
10 new ADU adoptions in Ordinance 7-2006.

11  
12 The Board rescinded its determination of invalidity as to the ADU development regulations pertaining  
13 to detached ADUs on June 30, 2006. At that time, the Board determined that the County's new  
14 development regulations did not pose a significant risk that inconsistent development would occur  
15 during the compliance remand period such that proper GMA planning could not ultimately take  
16 place. Contrary to the arguments of Petitioner W. Evans, this ruling was not a determination of  
17 compliance but a determination that the County had reduced the scope of its detached ADU  
18 regulations so that their continued validity would not substantially interfere with the ultimate  
19 fulfillment of the goals of the GMA during the pendency of the compliance determinations.

20  
21  
22 On compliance, different but related issues are before the Board: whether the County's adoption of  
23 Ordinance 7-2006 fails to comply with Goal 2 (reduction of sprawl) (RCW 36.70A.020(2)), Goal 8  
24 (natural resource industries) (RCW 36.70A.020(8)), the requirements for rural densities (RCW  
25 36.70A.070(5)), and the prohibition against allowing new urban development outside of urban  
26 growth areas (RCW 36.70A.110(1)). The challenge to compliance with Goal 2, Goal 8 and RCW  
27 36.70A.110(1) was also raised in the new petitions for review by two remaining petitioners (Ludwig  
28 and Wanda Evans).<sup>14</sup> None of the new petitions challenge compliance with RCW 36.70A.070(5)  
29 (the rural element requirements). Therefore, we will decide the rural densities issue as part of the  
30

31  
32 <sup>13</sup> Petitioners' Response to Objections and Brief in Support of Lifting Invalidity at 7

<sup>14</sup> By "remaining petitioners", we mean those petitioners who briefed and argued their issues at the hearing on the merits. Those who did not brief and argue their issues are deemed to have abandoned them.

1 compliance case only. The challenges in the new petitions to compliance with Goal 2, Goal 8 and  
2 RCW 36.70A.110(1) will be decided together with those same challenges in the compliance case.

3  
4 A. Rural densities and rural character. RCW 36.70A.070(5)(b) discusses the requirements for rural  
5 development:

6 Rural development. The rural element shall permit rural development, forestry, and  
7 agriculture in rural areas. The rural element shall provide for a variety of rural densities,  
8 uses, essential public facilities, and rural governmental services needed to serve the  
9 permitted densities and uses. To achieve a variety of rural densities and uses, counties may  
10 provide for clustering, density transfer, design guidelines, conservation easements, and other  
11 innovative techniques that will accommodate appropriate rural densities and uses that are  
12 not characterized by urban growth and that are consistent with rural character.

13 RCW 36.70A.070(5)(c) sets requirements for rural development and protection of rural character:  
14 Measures governing rural development. The rural element shall include measures that apply  
15 to rural development and protect the rural character of the area, as established by the  
16 county, by:

- 17 (i) Containing or otherwise controlling rural development;
- 18 (ii) Assuring visual compatibility of rural development with the surrounding rural area;
- 19 (iii) Reducing the inappropriate conversion of undeveloped land into sprawling, low-  
20 density development in the rural area;
- 21 (iv) Protecting critical areas, as provided in RCW 36.70A.060, and surface water and  
22 ground water resources; and
- 23 (v) Protecting against conflicts with the use of agricultural, forest, and mineral resource  
24 lands designated under RCW 36.70A.170.

25 In finding the prior detached ADU development regulations non-compliant with rural densities, the  
26 Board determined that the regulations essentially permitted a doubling of residential densities  
27 throughout the rural zones. This failed to comply with RCW 36.70A.070(5)(b) and (c). The present  
28 detached ADU regulations, however, allow a limited number (approximately 15) of rural and  
29 resource lot owners to add a new or converted detached ADU to the principal residence in those  
30 zones annually. The Board must consider whether the addition of approximately 15 detached  
31 ADUs<sup>15</sup>, under the restrictions placed upon them by County Code, will violate the requirement for  
32 rural densities in the rural zones.

---

<sup>15</sup> Although the development regulations limit the number of detached ADU permits to 12% of building permits issued in rural and resource lands the previous year, the unique circumstances and history of land development in the San Juans demonstrates that the absolute number of such building permits is and will remain extremely small.

1 Petitioners argue that the County has not addressed the Board’s finding that its detached ADU  
 2 regulations increased the structural density on rural lots.<sup>16</sup> It is true that the County did not amend  
 3 its regulations to prohibit all detached ADUs unless they are counted as additional residences for  
 4 purposes of conforming to the underlying densities. Instead, the County has provided that a  
 5 detached ADU will count as additional residential density unless constructed pursuant to an ADU  
 6 permit. The detached ADU permit requirements include regulations to strictly limit the number of  
 7 detached ADUs that may be constructed in rural and resource zones, requirements that they share  
 8 major utilities with the primary residence, locates them in proximity to the primary residence in ways  
 9 that minimize intrusions on critical areas and open-space features such as orchards and pastures,  
 10 and requires that a full ERU of water is available for use of the detached ADU. The Board must  
 11 determine whether this alternative approach complies with the requirements for rural densities in  
 12 RCW 36.70A.070(5).  
 13

14 The County asks the Board to find compliance, arguing that the Board was wrong in its earlier  
 15 determination that a detached ADU increases the structural density on a lot and that the Board  
 16 should have focused on population density instead<sup>17</sup>. Whatever the merits of this argument, it is too  
 17 late to bring it now. The Board’s determination that the County’s detached ADU regulations created  
 18 noncompliant structural densities in the rural lands was decided, appealed to the superior court  
 19 where it was affirmed, and then appealed to the court of appeals where it was dismissed by  
 20 agreement of the parties. There was no reversal of the Board’s determination and the Board, as  
 21 well as the parties, is bound by it. Compliance in this case must be assessed, therefore, in light of  
 22 the changes made to the prior noncompliant provisions of the ADU regulations.  
 23

24 In examining Ordinance 7-2006, the Board finds that first, that it now provides that “each detached  
 25 accessory dwelling unit shall be counted as a separate dwelling unit for density calculations...”<sup>18</sup>  
 26 This provision comports with the Board’s 2003 decision. Ordinance 7-2006 then provides a program  
 27 for exceptions to this principle:”...except when allowed pursuant to and ADU permit”<sup>19</sup>  
 28  
 29

30 \_\_\_\_\_  
 31 <sup>16</sup> Nelson, Participant’s Objection to Finding of Compliance at 8.

32 <sup>17</sup> San Juan County’s Pre-Hearing Brief

<sup>18</sup> SJCC 18 40.240(A)

<sup>19</sup> Ibid

1 The program for detached ADU permits contains four major changes to the prior ADU regulations for  
2 detached ADUs: first, there has been a cap placed on the number of detached ADUs that may be  
3 constructed or converted in any year outside of an urban growth area or designated limited area of  
4 more intensive rural development (in San Juan County these are called activity centers)<sup>20</sup>; second,  
5 the detached ADU must be located within 100 feet of the principal residence (up to 150 feet away if  
6 “impact” would be greater); third, the detached ADU must now share its septic/sewer system with  
7 the principal residence (in addition to sharing a driveway and water system); and fourth, a detached  
8 ADU must obtain a full equivalent residential unit of water available for use for the detached ADU in  
9 addition to the water required for the principal residence.

10 1) The cap. New SJCC18.40.240(G)(1)(b) provides:

11 Outside of the boundaries of activity centers and urban growth areas, the number of  
12 detached ADU permits in any calendar year shall not exceed 12 percent of the total number  
13 of building permits for new principal residences issued for the previous calendar year outside  
14 the boundaries of activity centers and urban growth areas. Two of that 12 percent (10  
15 percent new, 2 percent conversions) of the permits released in any one year shall be  
16 restricted for the conversion of existing accessory structures that have legally existed for no  
17 less than five years. ADU permits shall be issued on a first come/first served basis under  
18 procedures established by the administrator. No unassigned ADU permits shall carry  
19 forward to the next year.

20 The County avers that the absolute number of ADU permits, based on historical numbers of building  
21 permits issued outside of activity centers and urban growth areas, is estimated to be about 15 per  
22 year. Of that amount, 1/6<sup>th</sup> of the ADU permits are allocated to conversions of existing structures  
23 that have been legal for at least 5 years.

24 2) Location of the detached ADU. Unlike the prior development regulations, Ordinance 7-  
25 2006 now expressly limits the location of the detached ADU to within 100 feet of the main residence:

26 Distance. The maximum distance between the closest vertical walls of the main house and  
27 any detached accessory dwelling unit shall be no more than 100 feet. If the 100 feet  
28 dimension would result in a greater impact, the administrator may allow up to 150 feet  
29 separation.

30 SJCC 18.40.240(G)(2).

31 \_\_\_\_\_  
32 <sup>20</sup> ADUs are prohibited in Rural Industrial, Rural Commercial, Natural, and Conservancy Land Districts, as well  
as in the Island Centers District.

1 The question of “greater impact” that authorizes the administrator to allow up to 150 feet is described  
2 in the subsequent section. The location impacts are to “avoid or minimize intrusion on the most  
3 sensitive open-space features of the site”:

4 Location. Locate every new detached ADU and its utilities and driveway to avoid or minimize  
5 intrusion on the most sensitive open-space features of the site, including but not limited to:

- 6 a. Existing orchard, meadows an pasture areas;
- 7 b. Ridgelines and contrasting edges between landscape types unbroken by structures;
- 8 c. Rolling, open or steep open slopes;
- 9 d. Critical areas.

10 SJCC 18.40.240(G)(3).

11 3) Shared utilities. Ordinance 7-2006 amends SJCC 18.40.240 to provide:

12 Driveway and Utilities. An accessory dwelling unit shall use the same driveway,  
13 septage[sic]/sewer system, and water system as the principal residence.

14 SJCC 18.40.240(F)(3).

15 The requirement for a shared septic system is new to this version of the ADU development  
16 regulations.

17 4) Water availability. Ordinance 7-2006 further amends SJCC 8.06.070 regarding water  
18 required for a new detached ADU:

19 A detached accessory dwelling unit shall include evidence of the availability on site of one  
20 equivalent residential unit [ERU] of water in addition to the water required for the principal  
21 residence.

22 SJCC 8.06.070 (definition of “Connection”, in pertinent part).

23 The requirement for a full ERU of water for a detached ADU is distinguished from the amount of  
24 water availability required for an attached ADU. An attached ADU requires one-half of an ERU  
25 unless the owner can demonstrate that water use in the attached ADU will be less (up to 1/3 of an  
26 ERU)<sup>21</sup> Petitioners Marshall, Zeigler and Baldwin argue that this distinction was a last minute  
27 addition to the ordinance and did not reflect meaningful consideration of the arguments against it.<sup>22</sup>

28 Friends argues that the water requirement is a further limitation on the number of detached ADUs  
29 that may be constructed.<sup>23</sup>

30  
31  
32 <sup>21</sup> SJCC 8.06.070

<sup>22</sup> Baldwin/Marshall/Ziegler Prehearing Brief at 6.

<sup>23</sup> Friends’ response to Board questions at the hearing on the merits.



1 With these changes, the County has altered its course of doubling the density potential in rural and  
 2 resource lands and acknowledged that detached ADUs should count as additional density. The  
 3 amendments enacted by Ordinance 7-2006 count a detached ADU as a unit of density with a limited  
 4 exception.<sup>24</sup> This exception allows some detached ADUs on a permit basis.<sup>25</sup> In rural and resource  
 5 lands, the number of detached ADUs which may be permitted in any year is limited to 12 per cent of  
 6 the total number of building permits for new permanent residences issued outside of UGAs and  
 7 LAMIRDs the prior year. This is estimated, by reference to the past history of building permits  
 8 issued for single-family home construction in the rural and resource lands, to be about 15 per year.<sup>26</sup>

10 In order to assess the impact of this exception to the density limitation for detached ADUs, we turn  
 11 first to the County's Final Report on Accessory Dwelling Units.<sup>27</sup> According to this analysis, the total  
 12 of "non-urban" parcels (excluding state and federal lands) is 13,991. The average parcels size in the  
 13 rural and resource lands (excluding state and federal lands) is 7 acres.<sup>28</sup> The official land use maps  
 14 for San Juan County show a majority of the lots on all of the islands as designated as rural or  
 15 resource lands.<sup>29</sup> According to the official land use maps, rural densities vary from 1 dwelling unit  
 16 per 5 acres (1du/5 acres) to 1 du/10 acres. While there are preexisting smaller lots in the rural  
 17 zones, the general rule is that the maximum rural density is 1du/5 acres. This comports with general  
 18 density guidelines articulated by the growth boards and this rural density scheme has been found  
 19 compliant.<sup>30</sup>

22 Under Ordinance 7-2006, detached ADUs are permitted in the RFF (rural farm forest), RR (rural  
 23 residential) and RGU (rural general use) zones.<sup>31</sup> Based on the history of building permits in the  
 24 rural and resource zones, the County estimates that 12% of the building permits issued in those  
 25 zones will be only 15 a year. Given the number of potential parcels upon which detached ADUs

27 <sup>24</sup> SJCC 18.40.240(A)

28 <sup>25</sup> *Ibid.*

29 <sup>26</sup> SJCC18.40.240 (G)(1)(b).

30 <sup>27</sup> Exhibit 4, at 3

31 <sup>28</sup> *Ibid* at 21.

32 <sup>29</sup> Land Use Maps, Comprehensive Plan (San Juan County)

<sup>30</sup> *Michael Durland et al v. San Juan County*, Case No. 00-2-0062c and *Town of Friday Harbor, et al v. San Juan County*, Final Decision and Order/Compliance Order (May 7, 2001) at 20; *Michael Durland v. San Juan County*, Case No. 00-2-0062c, Order Finding Compliance and Rescinding Invalidity (October 11, 2001) at 2.

<sup>31</sup> SJCC 18.40.240(C).

1 may be constructed or converted, an annual limit of approximately 15 of such permits is unlikely to  
2 disturb the existing, compliant scheme of rural densities.

3  
4 However, it is also important to examine the nature and scope of the detached ADUs in determining  
5 their potential impact upon rural densities. Detached ADUs are limited to no more than 1,000  
6 square feet in size.<sup>32</sup> They must share water and septic/sewer with the principal residence.<sup>33</sup> They  
7 must also share a driveway and be located within 100 feet of the principal residence.<sup>34</sup> Further  
8 restrictions include only minimal intrusion in critical areas and open spaces.<sup>35</sup>

9  
10 In addition, detached ADUs under the San Juan County scheme are not separate residences in that  
11 they cannot be sold separately from the primary residence.<sup>36</sup> They may be rented but the rental  
12 term must be at least 30 days.<sup>37</sup>

13  
14 Another important aspect of rural densities is that they conform to the rural character of the specific  
15 county. The GMA recognizes rural character is not the same among counties and regions and  
16 requires each county to define its specific rural character:

17  
18 Because circumstances vary from county to county, in establishing patterns of rural densities  
19 and uses, a county may consider local circumstances, but shall develop a written record  
20 explaining how the rural element harmonizes the planning goals of RCW 36.70A.020 and  
21 meet the requirements of this chapter.

RCW 36.70A.070(5)(a).

22 *The San Juan County Accessory Dwelling Units Final Report* (Final Report)<sup>38</sup> describes the special  
23 conditions that make San Juan County's situation with respect to detached ADUs different from  
24 other counties:

25 The specific conditions of San Juan County, including transportation limitations of the island  
26 environment, and the long history of the islands as a vacation and retirement location, have  
27

28  
29 <sup>32</sup> SJCC 18.40.240(F)(1)

30 <sup>33</sup> SJCC 18.40.240(F)(3)

31 <sup>34</sup> *Ibid*; SJCC18.40.240(G)(2)

32 <sup>35</sup> SJCC 18.40.240(G)(3)

<sup>36</sup> SJCC 18.40.240(F)(4)

<sup>37</sup> SJCC 18.40.270 (L)

<sup>38</sup> Exhibit 4.

1           resulted in a rural environment with characteristics that are different from those of many rural  
2           counties in the state.<sup>39</sup>

3 San Juan County's comprehensive plan's describes its rural character:

4           ...Rural lands are intended to retain the pastoral, forested, and natural landscape qualities of  
5           the islands while providing people with choices for living environments at lower densities or  
6           use intensities than those in Activity Centers.<sup>40</sup>

7 San Juan County's development code further describes rural character as:

8           ...a quality of landscape dominated by pastoral, agricultural, forested and natural areas  
9           interspersed with single-family homes and farm structures.<sup>41</sup>

10 San Juan County's isolation, recognition as a tourist destination, historic use of ADUs for vacationing  
11 family members or as a vacation residence before a main house is built, and rural lot development  
12 pattern are unique characteristics. A process which maintains the ability to develop a small number  
13 of detached ADUs, constructed in proximity to the main residence and situated to maintain the open  
14 space features central to the rural areas, is in keeping with San Juan County's rural character.

15  
16 Taken together, the Board finds that the small number of detached ADU permits in rural lands, the  
17 shared utilities and driveway, the requirement that the detached ADU be relatively close to the  
18 primary residence, the size limitation and the location restrictions within the lot will have a minimal  
19 physical impact on rural densities. The fact that the detached ADUs are also attached to the primary  
20 residence as part of common ownership also reduces the risk that the detached ADUs will become  
21 simply another house on the same lot. In sum, the new detached ADU regulations do not act to  
22 upset the existing compliant rural densities in San Juan County. Where the challenged regulations  
23 allow such a limited number of detached ADUs to be constructed or converted on rural lands of 5 or  
24 more acres per parcel, we find that they do not create non-compliant rural densities. However, San  
25 Juan County has gone beyond allowing a limited number of detached ADUs on rural lands with  
26 compliant rural densities. The County also allows detached ADUs to be constructed or converted on  
27 rural lots as small as one acre.<sup>42</sup> These small rural lots were established before the GMA was  
28 adopted and would not ordinarily reflect an appropriate rural density. The County Comprehensive  
29

30  
31 <sup>39</sup> Exhibit 4, *San Juan County Accessory Dwelling Units Final Report* (August 14, 2002) at 7

32 <sup>40</sup> Section 2.3C of Land Use Element

<sup>41</sup> San Juan County, Unified Development Code at SJCC 18.20, page 20.

<sup>42</sup> SJCC18.40.240(G)(4)(b)

1 Plan acknowledges the existence of lots in the RR (rural residential) zone that are below 5 acres in  
2 size but notes that this is because they were established in the 1979 comprehensive plan:

3 Existing parcels which were established under the greater densities of the 1979 plan may still  
4 be developed for residential use, but any further subdivision in these areas must meet the  
5 newly established density limits. Plan policies encourage the combination of existing lots in  
6 order to reduce the number of dwelling units that may be developed in rural areas where the  
7 existing parcel pattern would permit development at a density greater than that established  
8 by this Plan and the Official Maps.

9 San Juan County Comprehensive Plan, Land Use Element at 2.

10 Allowing an additional detached residence on a nonconforming rural lot is not consistent with the  
11 County's own plan for rural densities and preservation of rural character. In addition, the County's  
12 regulations allow an additional footprint of up to 2,000 square feet on a nonconforming rural lot if the  
13 ADU is combined with a garage.<sup>43</sup> Such structural intensity does not conform to policies on rural  
14 densities under either the County's comprehensive plan or the GMA.

15 **Conclusion:** Ordinance 7-2006, as it applies to detached ADUs in existing, compliant rural zones,  
16 does not alter the existing compliant residential densities in those zones to an extent that violates  
17 RCW 36.70A.070(5). The development regulations limit the number of detached ADU permits to  
18 12% of building permits issued in rural and resource lands the previous year; the unique  
19 circumstances and history of land development in the San Juans demonstrates that the absolute  
20 number of such building permits is and will remain extremely small. However, the regulations that  
21 permit a detached ADU to be constructed or converted on a nonconforming rural lot of less than 5  
22 acres fail to comply with RCW 36.70A.070(5) because they expand the structural intensity in rural  
23 zones beyond that which is set out in the County comprehensive plan and do not conform to rural  
24 densities as defined by the GMA.  
25  
26  
27  
28  
29  
30  
31  
32

---

<sup>43</sup> SJCC 18.40.240(G)(4)(b)(ii)  
COMPLIANCE ORDER AND FINAL DECISION AND ORDER  
Case Nos. 03-2-0003c; 06-2-0024c  
February 12, 2007  
Page 21 of 76

**VI. ISSUES IN O6-2-0024c**

**A. Abandoned Issues**

No petitioner in WWGMHB 06-2-0024c briefed the following issues: 3, 6, 8, 15, 16, 17, 18, 19, 23, 24, 25 27, 32, 33, 35, 38, and 40. "An issue not addressed in petitioner's brief is considered abandoned".<sup>44</sup>

Conclusion: Petitioners have not carried their burden of proof pursuant to RCW 36.70A. 320(2) regarding Issues: 3, 6, 8, 15, 16, 17, 18, 19, 23, 24, 25 27, 32, 33, 35, 38, and 40.

**B. Sprawl Issues**

Issue 1: Does Ordinance 7-2006, Section 18.40.240 G(1)(b) fail to comply with Growth Board orders dated April 17, 2003 and July 21, 2005 and RCW 36.70A.020(2) and (8) by allowing freestanding ADUs in rural and resource lands subject to an annual quota system? (Manning et al., 06-15c, Nelson, 06-20, and Wanda Evans, 06-17)

Issue 2: Is Ordinance No 7-2006, Section 18.40.240 A – G noncompliant with RCW 36.70A.020, Planning Goals 1 and 2, by allowing densities of greater than one unit per five acres in rural lands and Goal 4, by increasing land values in rural lands? (Ludwig, 06-24)

Under this heading, we will discuss the challenges to compliance with Goal 2, Goal 8 and RCW 36.70A.110(1). We will discuss Goal 4 in the Affordable Housing Section of this order.

Positions of the Parties

**Petitioners' Positions**

Petitioner Ludwig states that Ordinance 7-2006 allows freestanding ADUs on lots of less than 10 acres.<sup>45</sup> Petitioner Ludwig cites Western Washington Growth Management Hearing Board cases, including the April 17, 2003 Corrected Final Decision and Order and decisions from the Central Growth Management Hearings Board that have held that allowing an ADU with a principal residence on a lot of less than 10 acres constitutes impermissible sprawl.<sup>46</sup> This Petitioner also declares that all three Boards have affirmed that one dwelling unit per five acres is the maximum permissible

<sup>44</sup> *WEC v. Whatcom County*, WWGMHB Case No. 95-2-0007. Also see *OEC v. Jefferson County*, WWGMHB Case No. 94-2-0017.

<sup>45</sup> Petitioners' Objections to a Finding of Compliance (June 27, 2006) at 1.

<sup>46</sup> Petitioner's Prehearing Brief (November 8, 2006) at 2 citing *1000Friends IV*, CPSGMHB Case No. 04-3-0012 (Final Decision and Order, Date) at 13, and *PNA II*, CPSGMHB Case No. 95-3-0071.

1 density in rural areas.<sup>47</sup> Petitioner says that the official San Juan County maps show a large  
 2 percentage of rural land platted on lots of five acres or smaller, and Ordinance 7-2006 would double  
 3 the density on rural lots. <sup>48</sup> Petitioner argues that a study done as a part of the review of County's  
 4 critical areas ordinance shows that all of San Juan County is a critical aquifer recharge area, and  
 5 therefore no more density than one unit per five should be allowed until the critical areas ordinance  
 6 is updated. <sup>49</sup> Because the County can't predict where new detached ADUs will be built, Petitioner  
 7 Ludwig contends these new ADUs constitute unplanned and uncoordinated growth which the  
 8 Growth Management Act (GMA) seeks to discourage.<sup>50</sup>

9  
 10 Petitioner Austin makes many of the same arguments as Petitioner Ludwig.<sup>51</sup> Petitioners Manning  
 11 and Blanchard and Marshall, Baldwin and Ziegler contend that the Ordinance still violates the  
 12 Board's order that a detached ADU shall conform to the underlying density in rural and resource  
 13 areas.<sup>52</sup>

14  
 15  
 16 Petitioner Wanda Evans alleges that because the Board has overturned its April 17, 2003 order, that  
 17 it should now find Ordinance 21-2002, the ordinance that the Board's April 17, 2003 order found  
 18 noncompliant and invalid, compliant. She argues that this ordinance is not much different than  
 19 Ordinance 7-2006 except the County's regulations for detached ADUs now contains a 12 percent  
 20 limit based on annual single-family development permits, rather than being based on the assumption  
 21 that the number of residential lots containing ADUs would never exceed more than 16 percent. She  
 22 contends that Ordinance 21-2002 is a better alternative because it was adopted with fairer public  
 23 process and allowed for conversions of outbuildings to detached ADUs. <sup>53</sup>

24  
 25 \_\_\_\_\_  
 26 <sup>47</sup> Ibid at 3 citing *City of Moses Lake v. Grant County*, EWGMHB 99-1-0016 (Order on Remand, 4/17/02),  
 27 *Bremerton/Port Gamble*, CPSGMHB 95-3-39c and 97-3-24c(9/8/97), *Butler v. Lewis County*, WWGMHB 99-2-  
 28 27c (Final Decision and Order, 6/30/00), *Better Brinnon v. Jefferson County*, WWGMHB Case No. 03-2-0007  
 (Compliance Order, 6-23-04), and *Dawes v. Mason County*, WWGMHB Case No. 96-2-23c(Compliance  
 Order, 3-2-01)

29 <sup>48</sup> Ibid at 4.

30 <sup>49</sup> Ibid at 4.

31 <sup>50</sup> Ibid at 4.

32 <sup>51</sup> Austin, Participant's Objection to Finding of Compliance at 1-2

<sup>52</sup> Manning and Blanchard, Opposition to Compliance Report and Motion to Lift Invalidity Filed by San Juan  
 County and Objection to a Finding of Compliance (July, 2006) at 2. Marshall et al, Objection to a Finding of  
 Compliance and Motion to Supplement the Record ( July 5, 2006) at 2.

<sup>53</sup> Petitioner's Prehearing Brief (November 14, 2006) at 1

1 **County's Position**

2 The County maintains that detached ADUs are counted as a dwelling unit for the purposes of  
3 complying with underlying density in rural and resource zones with a limited exception. The County  
4 argues that Ordinance 7-2006 only allows a small number of detached ADUs in close proximity to a  
5 primary residence that can only be rented long-term to provide a source of affordable housing. The  
6 County states that the primary limitation on detached ADUs is only allowing permits for only 12  
7 percent of the residential building permits per year with two percent of the 12 percent reserved for  
8 conversion of existing buildings to detached ADUs.<sup>54</sup> The County also asserts that Ordinance 7-  
9 2006 contains strict visual and environmental limitations on the construction of detached ADUs  
10 including provisions for the sharing of all utilities, an obligation for one equivalent residential unit  
11 (ERU) of water, prohibition of detached ADUs in natural or conservancy designations, and a  
12 minimum lot size.<sup>55</sup>

13  
14 The County argues that detached ADUs are part of the historic character of San Juan County and  
15 consistent with the present rural landscape. The County contends the manner in which the County  
16 has chosen to permit detached ADUs assures that the natural environment will continue to  
17 predominate over the man made and is compatible with the GMA's requirements to protect rural  
18 character.<sup>56</sup>

19  
20  
21 Board Discussion

22 **Sprawl**

23 Goal 2 of the GMA calls for reduction of sprawling, low-density development:  
24 Reduce sprawl. Reduce the inappropriate conversion of undeveloped land into sprawling, low-  
25 density development.  
26 RCW 36.70A.020(2)

27 In the Corrected Final Decision and Order of April 17, 2003, this Board found that the regulations for  
28 detached ADUs violated Goal 2 by converting rural and resource lands to sprawling, low-density  
29 development.

30  
31  
32 <sup>54</sup> Compliance Report and Motion to Rescind Invalidity (June 21, 2006) at 3 and 4.

<sup>55</sup> Ibid at 5

<sup>56</sup> Ibid at 5.

1 For the same reasons that we find that Ordinance 7-2006 does not alter the existing compliant  
2 residential rural densities, the Board finds that the new ADU regulations do not create sprawling,  
3 low-density development in the rural zones. The limited number of detached ADU permits coupled  
4 with the limitations on location, ownership, utilities and impact on the open-space features of the lot  
5 prevent the detached ADU regulations from creating sprawl in those rural zones.

6  
7 While we find that the provisions of SJCC 18.40.240(G)(4) fail to comply with the requirements for  
8 rural densities and rural character of RCW 36.70A.070(5)(b) and (c) by allowing expansion of the  
9 structural intensity in substandard rural lots, the Board does not find that they create sprawl at this  
10 time. The new ADU regulations allow the construction and conversion of detached ADUs in the rural  
11 residential zone on small rural lots of less than 5 acres. However, due to the limited number of such  
12 detached ADUs that may be permitted and the limitations on size, location and utilities, the  
13 Petitioners/Participants have not shown that this will create sprawl during the remand period. Since  
14 SJCC 18.40.240(G)(4) is remanded for compliance with RCW 36.70A.070(5)(b) and (c) and RCW  
15 36.70A0110(1), prompt compliance with those provisions will also cure the risk for sprawl.

16  
17 **Conclusion:** Ordinance 7-2006 adds only a limited number of detached ADUs in rural and resource  
18 lands every year. These detached ADUs are subject to strict controls and maintain close  
19 connections with the primary residence. They are not divisible from the primary residence and must  
20 share major utilities. Petitioners have not shown that this will create sprawl during the remand  
21 period. Therefore, Ordinance 7-2006 complies with Goal 2, RCW 36.70A.020(2), subject to a  
22 determination that continued validity of SJCC 18.40.240 may, if not made compliant during the  
23 remand period set in this order, substantially interfere with fulfillment of Goal 2..

24  
25 **Natural Resource Industries (RCW 36.70A.020(8))**

26 Goal 8 of the GMA is the natural resource industries goal:

27 Maintain and enhance natural resource-based industries, including productive timber,  
28 agricultural, and fisheries industries. Encourage the conservation of productive forest lands  
29 and productive agricultural lands, and discourage incompatible uses.  
30 RCW 36.70A.020(8).

31 Mr. Nelson argues that the new regulations concerning detached ADUs continue to allow an  
32 unlimited number of freestanding ADUs on lots of 10 acres in resource lands and therefore fail to



1 conserve resource lands.<sup>57</sup> However, the number of detached ADUs that may be constructed or  
2 converted annually in resource lands is extremely limited. All detached ADUs, whether in rural or in  
3 resource lands, are limited to an average of 15 per year. This is not an unlimited number; on the  
4 contrary, it is a very small absolute number. While it is true that the actual cap is a percentage of  
5 building permits issued in the rural and resource land zones, the configuration and development of  
6 land in San Juan County does not offer a significant likelihood that this will ever be significantly  
7 greater than 15.<sup>58</sup> That is, 15 detached ADUs in all rural and resource lands annually, not just in  
8 resource lands.

9  
10 Goal 8 pertains to the conservation and enhancement of natural resource lands so that they may be  
11 used for productive purposes. It also requires discouragement of incompatible uses. With the  
12 location requirements of Ordinance 7-2006, a detached ADU in resource lands must be located in  
13 the 100 foot vicinity of the main residence, with shared utilities and driveway. It also may not disturb  
14 orchards, meadows, and pastures, and may not interfere with the natural slopes and ridgelines of  
15 the property. The size of the detached ADU is limited to 1,000 square feet. Overall, there is no  
16 showing that a very small number of such detached ADUs would convert resource land to non-  
17 resource purposes, or would create an incompatible use.

18  
19 **Conclusion:** Petitioners/Participants have not met their burden of showing that the new detached  
20 ADU regulations will violate the natural resources industries goal by converting resource lands to  
21 non-resource purposes. Further, they have also failed to show that the limited number of detached  
22 ADUs located in close proximity to the main residence and situated to reduce any impact on the  
23 natural open space features of the property will constitute an incompatible use. The Board finds that  
24 no violation of Goal 8 has been proven.

25  
26 **Urban growth outside of urban growth areas (RCW 36.70A.110(1)).**

27 This provision of the GMA limits urban growth to urban growth areas:

28       Each county that is required or chooses to plan under RCW 36.70A.040 shall designate an  
29 **urban growth area or areas within which urban growth shall be encouraged and**  
30 **outside of which urban growth can occur only if it is not urban in nature.** Each city that  
31 is located in such a county shall be included within an urban growth area. An urban growth

32  

---

<sup>57</sup> Nelson, Objection to Finding of Compliance and Motion To Supplement the Record at 6.

<sup>58</sup>Exhibit 4, *San Juan County Accessory Dwelling Units Final Report* (August 14, 2002)

1 area may include territory that is located outside of a city only if such territory is characterized  
2 by urban growth whether or not the urban growth area includes a city, or is adjacent to  
3 territory already characterized by urban growth, or is a designated new fully contained  
4 community as defined by RCW 36.70A.350.  
5 RCW 36.70A.110(1) (emphasis added)

6 In our 2003 Corrected Final Decision and Order and Compliance Order in this case, the Board found  
7 that the sections of Ordinance 21-2002 “allowing a freestanding accessory dwelling unit on every  
8 single-family lot without regard to the underlying density in rural residential districts, including  
9 shoreline rural residential districts, fail to prevent urban sprawl, contain rural development, and,  
10 instead, allow growth which is urban in nature outside of an urban growth area.<sup>59</sup>

11 As discussed in the sections on rural densities and sprawl above, the new ADU regulations no  
12 longer allow a detached ADU on every single family lot. The question remains whether the  
13 exception for permitted detached ADUs in rural and resource lands allows growth which is “urban in  
14 nature” outside of urban growth areas.

15 “Urban growth” is defined in the GMA as:

16 Growth that makes intensive use of land for the location of buildings, structures, and  
17 impermeable surfaces to such a degree as to be incompatible with the primary use of land  
18 for the production of food, other agricultural products, or fiber, or the extraction of mineral  
19 resources, rural uses, rural development, and natural resource lands designated pursuant to  
20 RCW 36.70A.170.

21 RCW 36.70A.030(17)(in pertinent part).

22 In the *Quadrant* decision<sup>60</sup>, the Washington Supreme Court agreed with a King County  
23 determination that densities of one dwelling unit per acre constitute growth that is urban in nature. In  
24 general, residential densities of one dwelling unit per acre or per two acres are not rural densities.  
25 They are “incompatible with the primary use of land for the production of food, other agricultural  
26 products, or fiber, or the extraction of mineral resources, rural uses, rural development” because the  
27 residential uses dominate the parcel.  
28  
29  
30  
31

32 <sup>59</sup> Corrected Final Decision and Order and Compliance Order, April 17, 2003 at 26.

<sup>60</sup> *Quadrant v. Central Puget Sound Growth Management Board*, 154 Wn. 2d 224 (2005)

1 As described in Ordinance 7-2006, the addition of a detached ADU on rural residential parcels less  
 2 than 5 acres in size is inconsistent with rural development and rural uses.<sup>61</sup> The predominance of  
 3 residential structures on a rural parcel makes it inconsistent with” ...a quality of landscape  
 4 dominated by pastoral, agricultural, forested and natural areas interspersed with single-family homes  
 5 and farm structures.”<sup>62</sup> It therefore creates growth that is “urban in nature”, contrary to RCW  
 6 36.70A.110(1).

7  
 8 Finding compliance in instances where the detached ADU is permitted on a rural parcel of a  
 9 compliant rural density of 5 acres in size is a much closer call for the Board. Allowance of a  
 10 detached ADU on five acre rural parcels actually creates a structural density that is neither rural nor  
 11 urban. All three boards have considered that a rural density is generally at least one dwelling unit  
 12 per five acres.<sup>63</sup> However, local circumstances must be considered in determining whether that  
 13 general principle should apply. In determining whether a detached ADU on a rural parcel of 5 acres  
 14 creates urban growth here, the Board has looked carefully at the historical pattern of guesthouses in  
 15 the rural areas on the San Juan Islands. Because of that historical pattern, a detached ADU may  
 16 not create urban growth in San Juan County, that is, it may not impinge upon rural uses and rural  
 17 character. Where the residential structures are not “incompatible with the primary use of land for the  
 18 production of food, other agricultural products, or fiber, or the extraction of mineral resources, rural  
 19 uses, rural development” in the rural areas, urban growth is not created. Giving due deference to  
 20 the County Commissioners’ determination of the importance of detached ADUs in the rural areas,  
 21 the Board finds that the size and location restrictions on detached ADUs through the permit process  
 22 limit residential uses from dominating over the rural uses of the property where the parcel is 5 acres  
 23 or greater in size. The small number of such permits restrains the extent of such development in  
 24

25  
 26  
 27 <sup>61</sup> We distinguish between “urban growth” and “urban densities”. “Urban growth” exceeds rural and resource  
 28 land intensities. However, urban growth is not necessarily an appropriate urban density as a result. As in the  
 29 *Quadrant* case, urban growth may be at only suburban levels of density.

30 <sup>62</sup> San Juan County, Unified Development Code, SJCC at 18.20, page 20.

31 <sup>63</sup> See *Durland v. San Juan County*, WWGMHB Case No. 00-2-0062c (Final Decision and Order, May 7,  
 32 2001); *Sky Valley v. King County*, CPSGMHB Case No. 95-3-0068c (Final Decision and Order, March 12,  
 1996); *Yanisch v. Lewis County*, WWGMHB Case No. 02-2-0007c (Final Decision and Order, December 11,  
 2002); but see *Vashon-Maury v. King County*, CPSGMHB Case No. 95-3-0008c (Final Decision and Order,  
 October 23, 1995); and *City of Moses Lake v. Grant County*, EWGMHB Case No. 99-1-0016 (Final Decision  
 and Order, May 23, 2000) (holding that rural densities should be no greater than one dwelling unit per *ten*  
 acres).

1 any one area so it is most likely that detached ADU permits will be issued in different locations,  
2 rather than establishing a pattern of growth. Along with San Juan County's unique rural character  
3 and historical pattern of guesthouse development, these limitations help guard against creating  
4 growth that is urban in nature. While the Board has concerns about the potential for the creation of  
5 urban growth with detached ADUs on 5-acre rural parcels, we find that the ordinance has addressed  
6 many of them and is not clearly erroneous on the grounds of RCW 36.70A.110(1).

7  
8 **Conclusion:** SJCC 18.40.240(G)(4) allows the creation of urban growth in rural areas by permitting  
9 detached ADUs in parcels of substandard rural density. On such nonconforming lots, two  
10 residences predominate over the rural character and use of the land. This fails to comply with RCW  
11 36.70A.110(1).

12  
13 Where the parcels in question are 10 acres in size, the addition of a detached ADU does not create  
14 the specter of urban growth. Adding a detached ADU on a 5-acre parcel in rural lands is a much  
15 closer question. However, in light of the County's historical pattern of guesthouse construction, the  
16 limited number of detached ADUs that may be placed on rural lands of compliant 5-acre rural  
17 densities, and the restrictions on size and location, we find that the County's decision to allow  
18 permits for detached ADUs on some 5 acre rural parcels is not clearly erroneous as prohibited by  
19 RCW 36.70A.110(1)

20  
21 **C. ADUs and Affordable Housing**

22 Issue 2 (in part): Is Ordinance No 7-2006, Section 18.40.240 A – G noncompliant  
23 Goal 4, by increasing land values in rural lands? (Ludwig, 06-24)

24 Issue 4: Does the Ordinance 7-2006, Sections 6,7, 8, and 9 fail to encourage the availability of  
25 affordable housing to all economic segments of the population in violation of RCW 36.70A.020(4)  
26 and RCW 36.70A.540? (Gutschmidt, 06-20)

27 Issue 5: Does Ordinance 7-2006, Section 8, SJCC 18.40.270 C violate RCW 36.70A.011 by not  
28 allowing short-term rentals? (Wanda Evans, 06-17) Issue 28: Do the restrictions placed on ADUs in  
29 rural and resource lands by Ordinance 7-2006 violate 43.63A.215, as well as RCW 36.70A.020,  
30 RCW 36.70A.540, and RCW 36.70A.400 by allowing ADUs attached to the principal residence while  
31 restricting ADUs attached to either an otherwise allowed or existing accessory structure when  
32 neither location of an ADU contributes to additional structural density on rural or resource lands?  
(John Evans, 06-18)

1 Issue 29: Does Ordinance 7-2006, Sections 1 and 2, violate RCW 36.70A.400 and RCW  
2 43.63A.215, by limiting the permitting of detached ADUs to 12 percent of the building permits from  
3 the previous year and allowing only two percent of these permits to be conversions of existing  
4 buildings and by not allowing ADUs to be attached to a garage or other accessory building? (Wanda  
Evans, 06-18)

5 We will discuss these issues together, but not necessarily in the order above.

6 Position of the Parties

7 **Petitioners Positions**

8  
9 Most of these parties object to the conditions placed on detached ADUs and argue that they are  
10 excessive restrictions on ADUs. They claim that the restrictions do not comply with the GMA's  
11 Housing Goal or requirements to allow for ADUs, as well as various other statutes. In contrast,  
12 Petitioner Ludwig contends that allowing detached ADUs on rural and resource lands without  
13 counting them as additional density should not be allowed since it works to increase rental rates and  
14 raise property values.

15  
16 Petitioner Gutschmidt charges that the restrictions on detached ADUs imposed by Ordinance 7-2006  
17 that limits their development and adds to the expense of development. This, he claims, is in  
18 violation of the GMA's Housing Goal.<sup>64</sup>

19  
20  
21 Petitioner John Evans states that San Juan County has focused on structural density to protect rural  
22 character. For this reason, he argues that it makes no sense to place restrictions on ADUs attached  
23 to an existing structure, as the County has done. Since these types of ADUs do not increase  
24 existing structural densities, he argues that they unnecessarily impinge upon the rights of property  
25 owners to create additional affordable housing stock, housing for returning children, and  
26 opportunities for additional income.<sup>65</sup> He also argues that the limitations will have the effect of  
27 deterring the County's economic development since they contribute to the lack of affordable housing  
28 for workers in conflict with the GMA's economic development goal. He further contends that RCW  
29 36.70A.400 serves as recognition by the State and the GMA that ADUs separate from the main  
30

31  
32 <sup>64</sup> Brief (November 14, 2006) at 1-3.

<sup>65</sup> Petitioner's [J. Evans] Prehearing Brief at 3.  
COMPLIANCE ORDER AND FINAL DECISION AND ORDER  
Case Nos. 03-2-0003c; 06-2-0024c  
February 12, 2007  
Page 30 of 76

1 residence play an important role in providing affordable housing. Finally, he argues that the  
 2 limitations placed on ADUs have no basis in the record.<sup>66</sup>

3  
 4 Petitioner Wanda Evans makes many of the same arguments as Mr. Evans about ADUs attached to  
 5 accessory buildings, and asserts that the Central Puget Sound Growth Management Hearings  
 6 Board’s (Central Board) March 19, 1996 Final Decision and Order in *Peninsula Neighborhood*  
 7 *Association v. Pierce County*, CPSGMHB Case No. 95-2-007(PNII) supports allowing ADUs to be  
 8 attached to existing buildings.<sup>67</sup>

9  
 10 The argument of Petitioner Wanda Evans suggests that by not allowing ADUs to be attached to  
 11 accessory buildings without counting that as a detached ADU, the County is curtailing its ability to  
 12 provide for tourist activities. She says that San Juan County has in the past allowed for “farm stays”.  
 13 She states that this activity has provided property owners with extra income to keep property in  
 14 agriculture. She says that these activities should not be made illegal and by citing RCW 36.70A.011  
 15 she seems to imply that not allowing short-term rentals of all detached ADUs for this tourist business  
 16 violates this statute.<sup>68</sup>

17  
 18  
 19 Petitioner Ludwig, on the other hand, claims that the additional detached ADUs to be permitted  
 20 pursuant to Ordinance 7-2006 will make San Juan County’s affordable housing stock less affordable  
 21 and inconsistent with the GMA’s Housing Goal for two reasons. First, because ADUs can be rented  
 22 for as little as 30 days, this rental timeframe will make market rate and vacation rentals cost more  
 23 than 30 percent of a certain income, thus tending to make ADUs unaffordable. Secondly,  
 24 Ordinance 7-2006’s allowance for a detached ADU on a parcel with another residence will create  
 25 greater density and make these properties 50 to 75 percent more expensive. He says that these are  
 26 notorious facts that the Board can consider pursuant to WAC 242-02-670 (2) and (3) and also cites  
 27 an article by Peter Wolf called “Land In America: Its Value, Use, and Control”.<sup>69</sup>

30  
 31 <sup>66</sup> Ibid at 4.

32 <sup>67</sup> Petitioner’s [W. Evans] Prehearing Brief at 3.

<sup>68</sup> Petitioners Prehearing Brief at 2.

<sup>69</sup> Petitioner’s Prehearing Brief at 5

1 **County's Position**

2 Ordinance 7-2006 expands the base of affordable housing. Ordinance 21-2002 was found  
3 compliant with the GMA's affordable housing requirements, the County points out, and Ordinance 7-  
4 2006 expands the allowable development of ADUs as compared to the noncompliant and invalid  
5 provisions of Ordinance 21-2002.<sup>70</sup> The County maintains that a wide range of regulatory options  
6 exist and the County has the final choice among the options. The County asserts that all of the  
7 issues raised by the Petitioners John and Wanda Evans were discussed throughout the public  
8 process, staff reports, and studies.<sup>71</sup>

9  
10 The County explains that attached and internal ADUs can be rented without restriction, as can  
11 primary residences with an associated detached ADU. The County states that its only prohibition on  
12 the rental of detached ADUs is the rental of a detached ADU for less than 30 days without the rental  
13 of the primary residence. The County says its reason for this rental limitation is short-term rentals of  
14 detached ADUs would move away from the County's concept that detached ADUs are part of the  
15 primary residence. The County argues that this provision is necessary to curtail "development  
16 abuse" so that property owners cannot construct detached ADUs as separate structures to create  
17 free standing rental units.<sup>72</sup> At argument, Friends contended that this regulation was also instituted  
18 to preserve detached ADUs for permanent residents of the islands, who have in the past been  
19 evicted from such units during the tourist season, when higher rents could be charged to tourists  
20 who are visiting the islands on a short-term basis.

21  
22  
23 Board Discussion

24 **Background and Applicable Laws**

25 Petitioners challenge the compliance of the Ordinance with RCW 36.70A.011; Goal 4 (affordable  
26 housing) (RCW 36.70A.020(4)); Goal 5 (economic development), (RCW 36.70A.020(5)); RCW  
27 36.70A.400 (which requires compliance with RCW 43.63A.215(3)); and RCW 36.70A.540.

28  
29  
30  
31  
32 <sup>70</sup> San Juan county's Prehearing Brief at 11

<sup>71</sup> Ibid at 21.

<sup>72</sup> San Juan County's Prehearing Brief at 11 and 12.

1 The Housing Element of the comprehensive plan must address the need for housing at various  
2 income levels but it was not amended with the adoption of Ordinance 7-2006 and therefore there  
3 can be no challenge to it in this case.

4  
5 RCW 36.70A.540 authorizes a local jurisdiction to create an optional “affordable housing incentive  
6 program”:

7 Any city or county planning under RCW 36.70A.040 may enact or expand affordable housing  
8 incentive programs providing for the development of low-income housing units through  
9 development regulations.

10 RCW 36.70A.540.

11 However, there is no evidence that San Juan County has elected to create such a program and  
12 therefore this provision does not apply here.

13  
14 RCW 36.70A.011 does not create any requirements for counties but provides guidance for  
15 developing their rural elements. San Juan County has a compliant Rural Element and it is not the  
16 subject of this challenge. Therefore, Petitioner Wanda Evans’ challenge that rental limitations on  
17 detached ADUs cannot be inconsistent with this statute.

18  
19 The three challenges related to affordable housing properly before the Board, therefore, are the  
20 challenge to compliance with Goal 4, Goal 5 and RCW 36.70A.400. We will discuss them in reverse  
21 order.

22  
23 Through RCW 36.70A.400, the County has an obligation to comply with RCW 43.63A.215(3). It  
24 provides:

25 Unless provided otherwise by the legislature, by December 31, 1994, local governments  
26 shall incorporate in their development regulations, zoning regulations or official controls the  
27 recommendations contained in subsection (1) of this section. The accessory apartment  
28 provisions shall be part of the local government’s development regulations, zoning  
29 regulation, or official control. To allow local flexibility, the recommendations shall be subject  
30 to such regulations, conditions, procedures, and limitations as determined by the local  
legislative authority.

31 The recommendations referred to in subsection (1) of RCW 43.63A.215 are those developed by the  
32 Department of Community, Trade and Economic Development (CTED):



1 ...designed to encourage the development and placement of accessory apartments in areas  
2 zoned for single-family residential use.  
3 RCW 43.63A.215(1)(b) (in pertinent part).

4 No Petitioner cites to any portion of the CTED recommendations that the County is alleged to have  
5 violated. The Board cannot consider an argument that has not actually been made Further, RCW  
6 43.63A.215(3) expressly provides that the County may place conditions, procedures and limitations  
7 upon accessory dwelling units to allow "local flexibility". No evidence in the record is presented that  
8 the County's limitations on attaching ADUs to accessory buildings or limiting detached ADUs in rural  
9 and resource lands nor limiting building permits to 12 percent of the annual residential permits in  
10 rural and resource lands show that the County's new ADU regulations exceed the scope of such  
11 local flexibility. The Board finds that no violation of RCW 43.63A.215(3) and RCW 36.70A.400 has  
12 been shown.

13  
14 Mr. Evans challenges compliance with Goal 5. Goal 5 of the GMA encourages economic  
15 development:

16 Encourage economic development throughout the state that is consistent with adopted  
17 comprehensive plans, promote economic opportunity for all citizens of this state, especially  
18 for unemployed and for disadvantaged persons, promote the retention and expansion of  
19 existing businesses and recruitment of new businesses, recognize regional differences  
20 impacting economic development opportunities, and encourage growth in areas experiencing  
21 insufficient economic growth, all within the capacities of the state's natural resources, public  
22 services, and public facilities.

23 Many factors are needed for successful economic development and the County allows various kinds  
24 of ADUs as source of some of its affordable housing. Therefore, the likelihood of the limitations on  
25 County's ADU regulations on detached ADUs in rural and resource lands impeding economic  
26 development are small and do not cause these regulations to be inconsistent with RCW 36.70A.020  
27 (5), the Economic Development Goal of the GMA.

28  
29 Finally, there are two sets of challenges to compliance with Goal 4. On the one hand, Mr. Evans,  
30 Ms. Evans and Mr. Gutschmidt argue that the restrictions placed on ADUs will restrict the supply of  
31 affordable housing. On the other hand, Mr. Ludwig argues that the provisions for new detached  
32 ADUs will simply increase the value of existing housing and drive up housing prices further.

1 Goal 4 of the GMA seeks to:

2 Encourage the availability of affordable housing to all economic segments of the population  
3 of this state, promote a variety of residential densities and housing types, and encourage  
4 preservation of existing housing stock.

5 RCW 36.70A.020(4)

6 Absent an order of invalidity, now rescinded in this case, the burden of proof is upon Petitioners to  
7 show that Ordinance 7-2006 is not in compliance with the GMA.<sup>73</sup>

8  
9 Petitioners have not cited to any evidence that the County's ADU regulatory scheme will reduce the  
10 affordability of housing in San Juan County. Instead, Petitioner Ludwig refers us to the text "Land  
11 In America: Its Value, Use, and Control". However, that contains nothing relevant to the specifics of  
12 ADUs in San Juan County, but instead reaches the not surprising conclusion that rezoning property  
13 can increase its value.

14  
15 Nor is it sufficient to allege that we can take official notice of notorious facts pursuant to WAC 242-  
16 02-670 (2) to conclude that Ordinance 7-2006's rather modest allowance of ADU's will "result in all  
17 land in SJC becoming 50-75 percent more expensive."<sup>74</sup> Such a conclusion is well outside those  
18 facts "so generally and widely known to all well-informed persons as not to be subject to reasonable  
19 dispute or specific facts which are capable of immediate and accurate demonstration by resort to  
20 accessible sources of generally accepted authority".<sup>75</sup>

21  
22 Encouraging affordable housing is one of the thorniest problems facing local jurisdictions today. The  
23 factors affecting the cost of housing are numerous and there is no certainty that any one policy  
24 choice will result in more market-based affordable housing. For example, there is nothing to assure  
25 that developers will not respond to market forces by providing high-end housing for which there is  
26 substantial demand, whether on five acre rural lots or on high-density urban lots.

27  
28 Here, the County has studied the situation in which it finds itself and determined that ADUs can be a  
29 source of more affordable housing. In 2002, only 3 percent of residentially developed parcels rented

30  
31 \_\_\_\_\_  
32 <sup>73</sup> RCW 36.70A.320

<sup>74</sup> Petitioner Ludwig's Prehearing Brief at 5.

<sup>75</sup> WAC 242-02-670(2).

1 ADUs on a long-term basis.<sup>76</sup> The Housing Element of the comprehensive plan estimates that over  
 2 time ADUs will provide about 20 percent of the County’s low and moderate income population  
 3 affordable housing.<sup>77</sup> The Housing Element does not distinguish how many of these affordable  
 4 ADUs will be internal, detached, or detached. The County allows unlimited numbers of ADUs in  
 5 Activity Centers (LAMIRDs) and urban growth areas; unlimited numbers of internal and attached  
 6 ADUs in rural and resource areas; and, with the adoption of Ordinance 7-2006, a limited number of  
 7 detached ADUs in rural and resource lands. The County’s development regulations clearly utilize  
 8 ADUs as a potential source of affordable housing.

9  
 10 Moreover, Goals 4 and 5 do not apply in isolation. The County also has an obligation to harmonize  
 11 the GMA’s Housing Goal and Economic Development Goal with the Sprawl Prevention and Natural  
 12 Resource Industry Goals of the GMA. While Ordinance 21-2002, allowed for unlimited detached  
 13 ADUs with fewer restrictions, the Board found this ordinance noncompliant and invalid because it did  
 14 not comply and substantially interfered with GMA’s goals and requirements for preventing sprawl  
 15 (Goal 2) and conserving natural resource industries (Goal 8). Ordinance 7-2006 addresses these  
 16 concerns and balances all four goals.

17  
 18 **Conclusion:** Based on the foregoing, we find that the limitations placed on detached ADUs in rural  
 19 and resource lands adopted by Ordinance 7-2006 are within the County’s discretion pursuant to  
 20 RCW 43.63A.215. We also find that the County’s balancing of Goals 4 and 5 with other goals and  
 21 requirements of the GMA fits within the parameters set by the GMA. The Board further finds that  
 22 Ordinance 7-2006 is not inconsistent with RCW 36.70A.020(4), RCW 36.70A.020(5), RCW  
 23 36.70A.400, RCW 43.63A.215, RCW 36.70A.011 and RCW 36.70A. 540.

24  
 25 **D. Permitting**

26 Issue 7: Does Ordinance 7-2006, Section 18.40.240 G(1)(b) and Sections 1, 3, 5 fail to further the  
 27 goal of having applications for permits processed in a timely and fair manner to ensure predictability  
 28 in violation of RCW 36.70A.020(7)? (Gutschmidt, 06-20, Manning et al., 06-15c)

29  
 30  
 31  
 32 <sup>76</sup>Gutschmidt, Exhibit 4, San Juan County Accessory Dwelling Units Analysis, Final Report at 20.

<sup>77</sup> Comprehensive Plan’s Housing Element at 5.

1 Positions of the Parties

2 Petitioner Gutschmidt argues that the restrictions on detached ADUs imposed by Ordinance 7-2006  
3 that include compelling the use of the same driveway and utilities, the 12 percent annual limitation  
4 on the number of ADUs outside of urban growth areas, avoiding or minimizing intrusion in sensitive  
5 open space areas, requiring one equivalent residential unit (ERU) for a detached ADU limit the  
6 development of ADUs and adds to the expense of their development. These costly expenses and  
7 limitations, he argues, reduce opportunities for affordable housing and make the permit process time  
8 consuming, unpredictable and unfair. <sup>78</sup>

9  
10  
11 The County maintains that Ordinance 7-2006 does not interfere with the fair and timely processing of  
12 permits. The County says it requires a new type of "ADU permit" and a site plan so that the  
13 Administrator can determine if the applicant can meet the requirements for detached ADUs. The  
14 County maintains that issuing permits on a "first come, first served" basis is a universally accepted  
15 method of allocating a limited supply, certainly fairer than skill or chance, and another method has  
16 not been proposed. The County points out that it has provided written procedures for applications  
17 for ADU permits, allowance for telephone reservations, and ministerial review to ensure fairness and  
18 efficiency in the permit process. Additionally, the County states that it does not require engineering  
19 drawings for showing the location of detached ADUs avoidance of sensitive open space features,  
20 but simply requires a site plan so the County can evaluate this requirement. Finally, the County  
21 contends that the requirement for additional ADU of water is within the discretion of the County  
22 Council and consistent with state law. <sup>79</sup>

23  
24 Board Discussion

25 Petitioner Gutschmidt also contends that many of the same provisions that make detached ADUs  
26 unaffordable also make the permitting process unpredictable and unfair. Petitioner Gutschmidt does  
27 not give evidence to support his claim that these requirements are inequitable, nor do we find that  
28 requiring an application for the limited number of detached ADUs permits available in a calendar  
29 year gives an advantage to any applicant. The County has taken steps to make the permit process  
30

31  
32 <sup>78</sup> Brief (November 14, 2006) at 1-3.

<sup>79</sup> Ibid at 12 and 13.

1 more efficient and equitable by promptly publishing guidelines on how to apply for an ADU permit  
2 and for allowing for telephone reservations for ADUs to help make the permit system more  
3 accessible for those who must travel long distances to the permit office and nonresident applicants.

4 <sup>80</sup>

5  
6 Our examination of SJCC 18.40. 240 (G)(3) shows that the code provides criteria to use when  
7 issuing a building permit, which are issued on a case by case basis. ADUs on lands with critical  
8 areas also would have to meet San Juan County's critical area protection measures, Further, our  
9 examination of this code provision with regard to local conditions shows that the County is  
10 harmonizing its obligations for predictable and efficient permitting with its obligation to protect its  
11 rural character, defined in the San Juan County Code as "a quality of landscape dominated by  
12 pastoral, agricultural, forested and natural areas interspersed with single-family homes and farm  
13 structures".

14  
15 **Conclusion:** Based on the foregoing, that Ordinance 7-2006, Section 18.40.240 G(1)(b) and  
16 Sections 1, 3,5 comply with RCW 36.70A.020 (7).

17  
18 **E. Citizen Participation and Coordination**

19 **1. Public Process Challenges**

20  
21 Issue 9: Did San Juan County violate the public participation requirements of RCW 36.70A.130 and  
22 RCW 36.70A.140 by entering into the non-public development of a "Settlement Agreement" with the  
23 Friends of San Juans, and then enacting the substance of that Agreement against the advice from  
24 the Planning Commission and the Prosecuting Attorney, and without considering the potential  
25 improvements to the settlement draft that were offered by Petitioners and other public participants?  
(Baldwin et al, 06-16, Wiese 06-19)

26 Issue 10: Did the County's actions in adopting Ordinance 7-2006 violate RCW 36.70A.  
27 035(2)(a)(ii)? (John Evans, 06-18, Wanda Evans, 06-17, Wiese 06-19)

28 Issue 13 : Did the County fail to use good faith to ensure public participation and consider public  
29 input in developing Ordinance 7-2006 in violation of RCW 36.70A.020(11) and RCW 36.70A.140?  
(Gutschmidt, 06-20)

30 We discuss these issues together.  
31  
32

<sup>80</sup> Exhibit 24.

1  
2 Positions of the Parties

3 **Petitioners' Positions**

4 Petitioners Marshall, Baldwin and Ziegler in their Reply Brief abandoned the argument put forth in  
5 their opening brief that asked the Board to apply the procedural requirements in *Smith v. Skagit*  
6 *County*<sup>81</sup> to encourage greater concern for the appearance of fairness in public hearings. They  
7 acknowledge Friends' response that the appearance of fairness doctrine as codified in RCW  
8 43.36.010 does not apply to legislative decisions on comprehensive plan and development  
9 regulations.<sup>82</sup> Even so, these Petitioners argue that the GMA demands a meaningful and fair public  
10 process. They contend that the San Juan County Council did not have an open mind when  
11 considering amendments to comply with the Board decisions after the County Council had entered  
12 into a settlement agreement with Friends. Also, these Petitioners say that ignoring the advice of the  
13 County Prosecutor, as well as the Planning Commission show that County Council was not open to  
14 public comments.<sup>83</sup> They assert that allowing two minutes per participant did not allow for  
15 meaningful public discussion and that the County Council members appeared to have their minds  
16 made up.<sup>84</sup>

17  
18  
19 Petitioner Wanda Evans' statement for Issue 10 appears to address a failure of the County to  
20 discuss Friends' proposal with the Planning Commission before presenting it to the public.<sup>85</sup>  
21 However, her argument does not address how this violated RCW 36.70A.035(2)(a)(ii) as alleged.

22  
23 Petitioner Gutschmidt contends that Ordinance 7-2006 was a result of "back door" negotiations with  
24 Friends and the County Council did not act in good faith when it ignored the public outcry over the  
25 far reaching land use restrictions and the negative effect these restrictions would have on rural  
26 lifestyles, encouraging economic prosperity, and opportunities for small scale, rural based  
27 employment.<sup>86</sup>

28  
29  
30 <sup>81</sup> *Smith v. Skagit County*, 75 Wn.2a.715(1969)

31 <sup>82</sup> Petitioner' Reply to Intervenor's Response Brief at 1 -2

32 <sup>83</sup> Ibid at 3

<sup>84</sup> Prehearing Brief of Baldwin, Marshall, and Ziegler at 4.

<sup>85</sup> Petitioner's Prehearing Brief at 2.

<sup>86</sup> Brief at 5.

1  
2 Petitioner John Evans did not brief the issue that he raised in Issue 10.

3 **County's and Friends' Position**

4 The County and Friends argue that the circumstances surrounding the adoption of Ordinance 7-  
5 2006 is similar to the situation discussed in the August 8, 1998 Final Decision and Order in *City of*  
6 *SeaTac v. City of Burien*, CPSGMHB Case No. 98-2-0010 (*Burien*). There, appellants argued that  
7 the City of SeaTac adopted comprehensive plan and zoning ordinance amendments in conjunction  
8 with an interlocal agreement between the City of SeaTac and the Port of Seattle for expansion of the  
9 airport. Friends points out that the Court of Appeals, Division 2, upheld the City and found the  
10 amendments were influenced by, but were not the result of, a settlement.<sup>87</sup>

11  
12 The County and Friends acknowledge that County met with Friends to receive recommendations  
13 that the County agreed to review, but declare there was no formal agreement on the  
14 recommendations.<sup>88</sup> The County asserts that meeting with litigants does not violate the public  
15 participation requirements of the GMA. Friends insists that the settlement discussions were not a  
16 "done deal" and point out that the County adopted Ordinance 7-2006 after following a public  
17 participation plan that included three public workshops and hearings before the Planning  
18 Commission and the County Council.<sup>89</sup> Friends states that it submitted comments during this public  
19 process, just as every other participant. Both the County and Friends maintain that the amendments  
20 changed various times in response to public comments, and were adopted after extensive public  
21 participation.<sup>90</sup>

22  
23  
24 Friends interprets Wanda Evans' issue as a challenge to the County Council considering a proposed  
25 amendment to ADU ordinance that were different from Planning Commission's without having the  
26 Planning Commission consider it again.<sup>91</sup> At argument, Friends maintained that the amendments  
27 that the County Council made were among the alternatives considered by the Planning Commission  
28 before it made its recommendation to the County Council. Therefore, Friends asserts the County

29  
30 \_\_\_\_\_  
31 <sup>87</sup> Ibid at 15 and Response Brief of Intervenor Friends of San Juans at 6.

32 <sup>88</sup> Ibid at 4 and San Juan County's Prehearing Brief at 14.

<sup>89</sup> Response Brief of Intervenor Friends of San Juans at 4.

<sup>90</sup> Ibid at 6 and San Juan County's Prehearing Brief at 14.

<sup>91</sup> Response Brief of Intervenor Friends of San Juans at 6-7.

1 was not even obligated by RCW 36.70A.035(2)(ii) to hold the June 6, 2006 hearing, let alone to refer  
2 the amendments back to Planning Commission before considering them.

3  
4 Board Discussion

5 The public oarticipation requirements for cities and counties planning pursuant to RCW 36.70A.040  
6 are contained in RCW 36.70A.130(2)(a) . That subsection requires that counties and cities establish  
7 public participation program for annual amendments to comprehensive plans and periodic review of  
8 comprehensive plans. This subsection does not apply to actions taken to resolve an appeal brought  
9 to the growth hearings boards. RCW 36.70A.130(2)(b) provides an exception to the regular public  
10 participation program under those circumstances, so long as there is “appropriate public  
11 participation”. Petitioners argue that many of the amendments the County made to its ADU  
12 regulations should have been considered as annual amendments; we discuss that challenge under  
13 Procedural Issues. However, we consider whether there was “appropriate public participation”  
14 here.

15  
16 The provision of the GMA that does apply to Petitioners’ public participation challenge is RCW  
17 36.70A.140, which requires counties and cities “to establish and broadly disseminate to the public a  
18 public participation program for early and continuous public participation in the development of  
19 comprehensive plans and development regulations”. This provision also delineates what types of  
20 measures the public participation program needs to include. In cases where a jurisdiction is acting  
21 in response to a remand from the Board, this provision states that the County “shall provide for  
22 public participation appropriate and effective under the circumstances presented by the board’s  
23 order”. San Juan County has outlined its public participation program in its comprehensive plan.<sup>92</sup>  
24 Moreover, the County adopted a public participation program specifically for consideration of the  
25 amendments to its ADU regulations. This program included workshops, hearings before the  
26 planning commission, and opportunities for written comment.<sup>93</sup>  
27

28  
29 **Friends’ Involvement in the Public Process**

30  
31  
32 <sup>92</sup> San Juan County Comprehensive Plan, Section D, Administration, at 6.

<sup>93</sup> Record at 00268 – 000272.



1 Evidence in the record shows that Friends communicated with the County Commissioners and made  
2 recommendations for amendments to the ADU Ordinance before the County proposed  
3 recommendations to its ADU regulations. We agree with the County and Friends that meeting with  
4 challengers to settle a GMA dispute is not a violation of the GMA. In fact, the Board is authorized to  
5 extend its deadline for issuing a decision for specifically this purpose (RCW 36.70A.300(2)(b)), and  
6 has done so several times in this case.

7  
8 The record shows that there was full public participation here and that it was not an abbreviated  
9 process. The Commissioners sent the Planning Commission a September 1, 2005 draft version of  
10 amendments that allowed for a limited number of detached ADUs subject to restrictions. This draft  
11 was the subject of several workshops, as well as hearings before the Planning Commission and  
12 June 6, 2006 County Council public hearing.<sup>94</sup> During this time the amendments changed several  
13 times. The Planning Commission rejected the September 1, 2005 draft and recommended that  
14 detached ADUs be allowed only if the lot contained the underlying density for a second dwelling unit.  
15 The letters in the record from Friends indicate that it supported the September 1, 2005 draft  
16 recommended amendments and gave qualified support to the County Council's proposed  
17 amendments with suggested changes to the Planning Commission's recommendations, which  
18 became the subject of the County Council June 6, 2006 public hearing.<sup>95</sup> However, Friends also  
19 supported the Planning Commission's recommendations.<sup>96</sup> The evidence shows nothing more than  
20 that Friends participated in the public process to ensure their views were heard.  
21

22 **Enactment Against the Advice of the Planning Commission and Prosecuting Attorney**

23 In regard to the claim that the County Council did not follow the advice of the County Prosecutor or  
24 the Planning Commission, public participation does not dictate a particular outcome or that the  
25 County Commissioners must accept the views of staff. As we said in an earlier decision:

26           The mere fact that the BOCC reached a different decision than one recommended by staff,  
27           the planning commission, and the citizens advisory committee did not ipso facto show a  
28           violation of public participation.<sup>97</sup>

29  
30  
31 <sup>94</sup> Record at 00312, 000349, 000351, 000497, 0000664, Legal Advertisement for the June 6,, 2006 public  
32 hearing

<sup>95</sup> Record 000383 -000388 and 00082

<sup>96</sup> Record at 000820

<sup>97</sup> *Achen v. Clark County*, WWGMHB Case No. 95-2-0067 (Final Decision and Order, September 20, 1995).  
COMPLIANCE ORDER AND FINAL DECISION AND ORDER  
Case Nos. 03-2-0003c; 06-2-0024c  
February 12, 2007  
Page 42 of 76

1  
2 **Violation of Public Process Requirements of RCW 36.70A.035**

3  
4 Petitioner Wanda Evans' challenge to the County's adherence to the public participation  
5 requirements of RCW 36.70A and the timing of the Planning Commission's involvement is not  
6 supported by evidence, citation to authority or by argument. While she alleges that Ordinance 7-  
7 2006 "did not come before the public through the proper process"<sup>98</sup> she does not identify any  
8 particular deficiency in that process. If her argument is that the County Council was required to  
9 send its draft amendments back to the Planning Commission for additional review, this is not what  
10 RCW 36.7A.035(2) requires. The statute provides only that if the legislative body chooses to  
11 consider a change that is proposed after the opportunity for review and comment has passed, then  
12 an opportunity for review and comment on the change shall be provided before the body votes.  
13 Here, it is clear that the changes made by County Council were before the public from the onset of  
14 the process.<sup>99</sup> The Council did hold a public hearing on its changes.<sup>100</sup>

15  
16 **Predetermination of the Issues**

17 In regard to Petitioners Marshall, Baldwin, and Ziegler's allegation that the County Council had made  
18 up its mind and added requirements without discussing them with the public at the hearing, the GMA  
19 does not require the County to demonstrate how the County Commissioners were thinking. We  
20 have said:

21       However, the GMA does not give the boards authority to probe the internal thought  
22 processes of a local decision-maker. It is not the task of the Board to judge how open a  
23 legislative body or individual member of that body is to an advisory committee's or a staff  
24 member's recommendation. The Board has the authority to decide whether the County  
25 follows their established public process, whether their decision is within the alternatives  
26 considered by the public, and whether their decision is consistent with the GMA. ...<sup>101</sup>

27 Thus, we will review the process by which an ordinance is adopted, as well as the ordinance itself,  
28 for consistency with the GMA, but we will not second guess the motivations of the legislative body.

29  
30 \_\_\_\_\_  
31 <sup>98</sup> Petitioner W. Evans Brief at 2.

32 <sup>99</sup> 0000312, 000349, 000351, 000497.

<sup>100</sup> 000664, Legal advertisement for the June 6, 2006 public hearing.

<sup>101</sup> *Diehl v. Mason County*, WWGMHB Case No. 95-2-0023 (Order Denying Petitioner's Request to Supplement the Record, April 2, 2003)-

1 Unless Petitioners can demonstrate that the process or product are in in violation of the GMA, our  
2 inquiry ends.

3  
4 **Adequate Opportunity to Testify**

5 At argument, the County responded to Petitioners' assertion that two minutes per participant did not  
6 provide enough time for meaningful public comment at the June 6, 2006 public hearing. The County  
7 pointed out that after the initial public comment period was finished, participants were invited to add  
8 comments. The County also invited written comments<sup>102</sup>. Additionally, staff reports and the Planning  
9 Commission findings indicate extensive public participation throughout the entire public participation  
10 process on the alternative that was eventually adopted.<sup>103</sup> We find that, in light of the entire record,  
11 and the fact that the County also allowed written comments in conjunction with the June 6, 2006  
12 public hearing, the County's limitation on the length of testimony did not violate RCW 36.70A.140.  
13 See *Achen v. Clark County*, WWGMHB Case No. 95-2-0067 (Final Decision and Order, September  
14 20, 1995)

15  
16 **Adequate Consideration of Public Comments**

17 Finally, as to Petitioner Gutschmidt's charge that the County Council ignored residents' views on the  
18 limitations on the location and size of parcel and the dwelling unit requirements for detached ADUs,  
19 the GMA does not require the legislative body to agree with those who testify. This Board's  
20 previous ruling applies here:

21 The GMA requires that a public participation process be provided, but does not require the  
22 decision-maker to agree with the positions urged by its citizens.<sup>104</sup>

23 **Conclusion:** Based on the foregoing, Petitioners have not carried their burden of proof that the  
24 County's public participation process was clearly erroneous and in violation of RCW 36.70A.140,  
25 RCW 36.70A.130, RCW 36.70A.035, or RCW 36.70A.020(11).  
26

27  
28 **2. Notice Challenges**  
29  
30

31  
32 <sup>102</sup> Record at 00064, Legal Advertisement for June 6, 2006 Public Hearing

<sup>103</sup> Record at 000495 and 000579

<sup>104</sup> *Wells v. Whatcom County*, WWGMHB Case No. 97-2-0030(Final Decision and Order, January 15, 1998).  
COMPLIANCE ORDER AND FINAL DECISION AND ORDER  
Case Nos. 03-2-0003c; 06-2-0024c  
February 12, 2007  
Page 44 of 76

1 Issue 11: Did the Ordinance 7-2006 violate RCW 36.70A. 035(1) (c) by not notifying Class A and  
2 Class B water systems of the legislation affecting private water systems established by Ordinance 7-  
3 2006? (Wanda Evans, 06-17)

4 **Petitioner's Position**

5 Petitioner Evans argues that the more than 300 private Class A and Class B water systems were not  
6 notified of the provision in the Ordinance 7-2006 that would affect their plans, policies and bylaws  
7 and this lack of notice violates RCW 36.70A.035(1)(c).<sup>105</sup>

8  
9 **County's Position**

10 The County replies that the amendment that requires one ERU of water for a detached ADU did not  
11 affect water plans, their policies or bylaws, and only impacts persons who want to apply for an ADU  
12 permit, a generalized group. The County says that this change does not affect whether the water  
13 system has enough water to provide an ERU, but sets the requirement that a detached ADU needs  
14 one ERU of water. The County points out that notifying public or private groups is only one possible  
15 notification method recommended by RCW 36.70A.035(1) and that is not required by the GMA. For  
16 these reasons, the County maintains that newspaper notification was adequate notice for water  
17 system members.<sup>106</sup>

18  
19 Board Discussion

20 RCW 36.70A.035(c) lists as an example of reasonable notice methods the notification of public or  
21 private groups with a known interest in a certain proposal or the type of proposal being considered.  
22 RCW 36.70A.035(1) does not require that every example be utilized in the County's notice methods.  
23 Also see WAC 365-195-600(2) and (2)(v). The County established a specific publication  
24 participation process for consideration of its ADU amendments that included a provision for public  
25 notice. The method of public notice that the County chose was notification by newspaper.<sup>107</sup>  
26 Specific notification to water systems users or Board members was not required.  
27

28 **Conclusion:** The County's provided notification by newspaper of its workshops and public hearings  
29 as specified in its public participation process for considering its ADU amendments. The GMA does  
30

31 <sup>105</sup> Petitioner's Prehearing Brief at 2

32 <sup>106</sup> San Juan County's Prehearing Brief at 18-19

<sup>107</sup> Record at 000271

1 not require specific notice to private water systems, in this circumstance. The County's method of  
2 public notification for consideration of its ADU amendments complies is with RCW 36.70A.035 (1).

3  
4 Issue 12: Did Ordinance 07-2006 violate the San Juan County Code, by inserting "Lot Coverage"  
5 legislation in an ordinance that is advertised as an Accessory Dwelling Unit Ordinance without  
6 proper public process and without using the annual docket process? (Wanda Evans, 06-17)

7 Without Petitioner specifying what part of the County's code or specific statute is alleged to have  
8 been violated, the Board can not decide this issue.

9  
10 **Conclusion:** Petitioner has not carried her burden of proof in demonstrating that the County's  
11 inclusion of lot coverage provisions in Ordinance 7-2006 was a clearly erroneous violation of the  
12 GMA.

#### 13 14 **F. PROCEDURAL ISSUES**

15  
16 Issue 20: Does Ordinance 7-2006 impermissibly address issues which were adequately addressed  
17 in the prior code provisions, and were not part of the Board's earlier finding of noncompliance and  
18 invalidity in violation of RCW 36.70A.130 (1), (2)(a)(b) and (7)? (Baldwin et al. 06-16)

19 Issue 22: Did the County violate RCW 36.70A.305, RCW 36.70A.330, and RCW 36.70A.140 by  
20 going well beyond the issues of noncompliance? (John Evans, 06-18)

21 We will discuss these two issues together.

#### 22 Positions of the Parties

##### 23 **Petitioners' Positions**

24 Petitioners declare that, except for regulations for detached ADUs, the County's ADU regulations  
25 have withstood compliance challenges. In spite of that, Petitioners Marshall, Baldwin, and Ziegler  
26 assert that the County Council impermissibly revised or added to compliant sections of the ADU  
27 regulations for parking, locating detached ADUs to avoid sensitive areas such as orchards,  
28 meadows, pastures ridgelines and critical distance from the main building, and providing of water  
29 supply.<sup>108</sup> These Petitioners contend that these regulations create odd policy implications because  
30  
31  
32

<sup>108</sup> Prehearing Brief of Baldwin, Marshall, and Ziegler at 10.  
COMPLIANCE ORDER AND FINAL DECISION AND ORDER  
Case Nos. 03-2-0003c; 06-2-0024c  
February 12, 2007  
Page 46 of 76

1 the revised regulations apply to all ADUs in all zones, even urban zones. Petitioners say that there  
2 is no apparent reason for the County to establish different restrictions that do not apply to similar  
3 housing such as duplexes.<sup>109</sup>

4  
5 These Petitioners state RCW 36.70A.130(2) requires that updates, proposed revisions, and  
6 amendments to comprehensive plans and development regulations should be considered no more  
7 frequently than once per year so that the cumulative effect of proposals can be ascertained.

8 Petitioners point out the Prosecuting Attorney advised the Council and the Planning Commission  
9 that the changes to ADU regulations could not go beyond the order of invalidity and were subject to  
10 the annual amendment process. Petitioners affirm that the Planning Commission followed the  
11 Prosecutor's advice, but the County Council did not.<sup>110</sup>

12  
13 Petitioners also argue that this Board has previously ruled in its November 30, 2000 Order on  
14 Rescission of Invalidity and Compliance/Invalidity in *Town of Friday Harbor v. San Juan County*,  
15 WWGHMB Case No 99-2-0010c (*Friday Harbor*) that, in a similar situation, the County could not go  
16 beyond the issue on remand in its compliance proceedings.<sup>111</sup>

17  
18 Petitioner John Evans argues the same issues raised by Petitioners Baldwin, Marshall, and Ziegler  
19 and also contends that shoreline issues are changes that are not within the scope of the remand.<sup>112</sup>  
20 He says that RCW 36.70A.140 directs that a more limited process be followed to address remand  
21 orders. He contends that a response to a Growth Board order is not license for the County to make  
22 wholesale amendments beyond the scope of the Growth Board's order. He asserts that RCW  
23 36.70A.330 and RCW 36.70A.305 describes an abbreviated and limited process, which the County  
24 exceeded here.  
25

## 26 **County and Friends' Positions**

27  
28 The County and Friends respond that many of the requirements that the Petitioners allege were  
29 changed, including parking rules, requirements to locate detached ADUs to avoid or minimize  
30

31 <sup>109</sup> Ibid at 10.

32 <sup>110</sup> Ibid at 11.

<sup>111</sup> Ibid at 9.

<sup>112</sup> Petitioner's Prehearing Brief at 1 and 2.

1 intrusion on sensitive areas, and ownership requirements, actually did not change.<sup>113</sup> Friends points  
2 out that these conditions also applied in both urban and rural areas under Ordinance 21-2002.<sup>114</sup>  
3 Both the County and Friends emphasize that the new conditions only apply to detached ADUs.  
4 Friends acknowledges that the requirement to locate the detached ADUs within a certain distance  
5 from the principal residence is new, and applies in both urban and rural areas, but argues that this  
6 requirement would have little impact in an urban area, and does not rise to the clearly erroneous  
7 standard.<sup>115</sup> Friends maintains that the limitations are necessary to prevent the significant potential  
8 for abuse caused by the County's original policy of allowing freestanding ADUs on all lots within rural  
9 and resource lands without taking them into account when calculating residential densities.<sup>116</sup>

10  
11 Friends disputes the applicability of *Friday Harbor v. San Juan County*.<sup>117</sup>

12  
13 Board Discussion

14 We dispose of Mr. Evans assertion that exceeding the scope of the remand order violated with RCW  
15 36.70A.305. RCW 36.70A.305 applies to judicial review of invalidity orders issued by growth boards  
16 and does not apply here.

17  
18 Petitioners also contend that the limitations on detached ADUs went beyond the scope of the  
19 compliance order, which does not comply with RCW 36.70A.130 (1), (2)(a)(b) and (7), RCW  
20 36.70A.140, and RCW 36.70A. 330. RCW 36.70A.130 states that comprehensive plans and  
21 development regulations shall be subject to periodic review and evaluation by the county or city that  
22 adopted them. RCW 36.70A.130 sets out the requirements for both annual amendments to the  
23 comprehensive plan as well as the periodic review required every several years for cities and  
24 counties on a schedule established in RCW 36.70A.130 (4). RCW 36.70A.130 (2)(a) specifies the  
25 requirements for public participation for annual comprehensive plan updates and for periodic view.  
26 RCW 36.70A.140 requires the counties and cities to develop and publish a public participation  
27 program that provides for early and continuous public participation and to broadly disseminate that  
28

29  
30 <sup>113</sup> San Juan County's Prehearing Brief at 20, Intervenor Friends of San Juans' Response to Prehearing Brief  
of Baldwin, Marshall, and Ziegler at 4 and 5.

31 <sup>114</sup> Intervenor Friends of San Juans' Response to Prehearing Brief of Baldwin, Marshall and Ziegler at 4 and 5.

32 <sup>115</sup> Ibid at 5.

<sup>116</sup> Response Brief of Friends of San Juans at 2.

<sup>117</sup> Intervenor Friends of San Juans' Response to Prehearing Brief of Baldwin, Marshall, and Ziegler at 5.

1 program to the public. RCW 36.70A.140 also allows a County subject to an order of invalidity to  
2 modify its public participation program to fit the circumstances presented by the Board's order.  
3 RCW 36.70A.330 requires cities and counties subject to a remand order achieve compliance at time  
4 set for complying in the Board's remand order. At issue here is whether the County went beyond the  
5 scope of the Board's order and added regulations that should have been addressed in the County's  
6 annual amendment process pursuant to RCW 36.70A.130(2)(b).

7  
8 From our comparison of Ordinance 7-2006 and Ordinance 21-2002, the Board concludes that the  
9 provisions that Petitioners denote as being new, including requirements for parking, locating or  
10 minimizing the intrusion of ADUs on sensitive areas, and ownership requirements were substantially  
11 present in Ordinance 21-2002.<sup>118</sup>

12  
13 The County and Friends point out that the rest of the changes only pertain to detached ADUs. The  
14 Board finds that the limitations on location and services to new detached ADUs are important to the  
15 Board's determination that Ordinance 7-2006 does not alter the existing, compliant scheme of rural  
16 densities. Similarly, the County's concern as stated in its brief that detached ADUs would more  
17 likely use more water than attached or internal ADUs is a legitimate concern to address in light of  
18 San Juan County's water sources.<sup>119</sup>

19  
20  
21 As for the Petitioners' argument that applying the same restrictions to detached ADUs in urban  
22 areas as to ADUs in rural and resource lands is beyond the scope of this order, the Board finds that  
23 the subject of the Board's remand order is detached ADUs. How the County chooses to reach  
24 compliance on that subject is not limited by the Board's analysis, but is within the County's discretion  
25 so long as it falls within the parameters set by the GMA.<sup>120</sup>

26  
27  
28  
29 <sup>118</sup> Ordinance 21-2002 at SJCC 18.40.240(B), 18.40.240 (D)(1-4), and 18.40.240 E vs. Ordinance 7-2006  
30 18.40.240(F)(2), 18.20.240(4), and 18.40.240 (G)(3).

31 <sup>119</sup> San Juan County Comprehensive Plan at 4.1.

32 <sup>120</sup> Further, the Board reminds Petitioners that the County has very few urban designations. The Board also  
notes that that the urban growth areas in the County's jurisdiction have yet to be found compliant. While it  
might make sense to have less restrictions in urban growth areas where urban growth is to be encouraged,  
these restrictions are within the County's discretion pursuant to RCW 43.63A.215.



1 Finally, we agree with Friends that *Friday Harbor* does not apply in this circumstance. Here the  
2 County is addressing how to make their regulations for detached ADUs compliant, the issue  
3 remanded in the Board's April 17, 2003 order, while in *Friday Harbor*, the County was working under  
4 a remand order that did not include noncompliant resources lands. In that instance, the County went  
5 beyond the scope of the compliance order when it re-designated 1000 acres of resource lands.<sup>121</sup>

6  
7 **Conclusion:** The Board finds that in light of the entire record the County did not go beyond the  
8 scope of the remand order and the amendments to the County's ADU regulations were not clearly  
9 erroneous violations of RCW 36.70A.130 (2)(b), RCW 36.70A. 330(1), or RCW 36.70A.140.

10  
11 Issue 21: Did the failure of Ordinance 7-2006 to set forth the goals and provisions of the GMA that  
12 were considered violate RCW 36.70A.130 and RCW 36.70A.140 by failing to afford the public an  
13 opportunity to comment at a public hearing on the rationale being considered? (Baldwin et al, 06-  
14 16)

15 Positions of the Parties

16 **Petitioner's Position**

17 The Petitioners Marshall, Baldwin, and Ziegler ask that the Board interpret the GMA's public  
18 participation provisions to clarify that the body of land use ordinances and public notices of city and  
19 county councils be required to contain the provisions of the GMA or the rationale that is being  
20 considered to provide for meaningful public comment. Petitioners contend that this is an implicit  
21 GMA requirement.<sup>122</sup>

22  
23  
24 These Petitioners state the Planning Commission recommendation was substantially altered, even  
25 after there was much public testimony objecting to changing this recommendation. Petitioner  
26 Marshall attests that citizens had to testify on the final draft of the ordinance without knowing the  
27 rationale and that this hindered their testimony.<sup>123</sup> Petitioners argue that by taking action on these  
28 changes without explanation the County violated that portion of RCW 36.70A.130(1) that states (in  
29 part):

30 \_\_\_\_\_  
31 <sup>121</sup> Order on Rescission of Invalidity and Compliance/Invalidity in *Town of Friday Harbor v. San Juan County*,  
32 WWGHMB Case No 99-2-0010c at 10.

<sup>122</sup> Prehearing Brief of Petitioners Baldwin, Marshall, and Ziegler

<sup>123</sup> Ibid at 15.

1 Legislative action means the adoption of a resolution or ordinance following notice and a  
2 public hearing indicating at a minimum, a finding that a review and evaluation has occurred  
3 and identifying the revisions made, or that a revision was not needed and the reasons  
therefor.<sup>124</sup>

4 **County and Friends' Position**

5 The County maintains that it has complied with RCW 36.70A.140 requirements, although in the  
6 circumstance where a regulation has been remanded to the Board for compliance, strict adherence  
7 to its public participation program is not required.<sup>125</sup> Friends adds almost the complete text for  
8 changes proposed by the County Council was included in the public notice for the June 6, 2006  
9 public hearing.<sup>126</sup> Other pertinent arguments are included in the County's and Friends' position  
10 statements under Public Process Challenges.  
11

12 Board Discussion

13 In the Discussion Section of Issues 20 and 21, the Board explained that RCW 36.70A.130 sets out  
14 requirements for annual updates and periodic review and RCW 36.70A.140 establishes the public  
15 participation program requirement. Petitioners claim that the County Council did not comply RCW  
16 36.70A.130 (1) by not providing a rationale for the changes it made to the Planning Commission's  
17 recommendations. Thus, they allege, they were denied the opportunity to provide meaningful public  
18 comment. However, nowhere does RCW 36.70A.130(1) require a local jurisdiction to explain the  
19 reasons for its amendments. While this a good practice and often appears in the "Whereas"  
20 sections of an ordinance, it is not required specifically by RCW 36.70A.130(1). That section applies  
21 to the periodic review requirement required by RCW 36.70A.130(1) rather than to comprehensive  
22 plan amendments generally. The "legislative action" referred to in RCW 36.70A.130(1)(b) that  
23 requires 'a finding that a review and evaluation has occurred and identifying the revisions made, or  
24 that a revision was not needed, and the reasons therefore" is a requirement that applies to periodic  
25 updates that counties and cities planning according RCW 36.70A.040 are required to undertake and  
26 complete according to the schedule set out RCW 36.70A.130(4). It does not apply to annual  
27 amendments and development regulations or to amendments made in response to a Board order.  
28 Therefore, Petitioners' challenge that the County's lack of explanation about reasons for their  
29  
30

31 \_\_\_\_\_  
32 <sup>124</sup> Ibid at 17.

<sup>125</sup> San Juan County's Prehearing Brief at 14.

<sup>126</sup> Response Brief of Friends of San Juans at 6.

1 changes to the Planning Commission's recommendations does not comply with RCW 36.70A.130(1)  
2 fails.

3  
4 As for Petitioners argument that the County did not comply with RCW 36.70A.140, we found above  
5 the County's public process for adopting Ordinance 7-2006 complied with RCW 36.70A.140. We  
6 also note that the amendments that the County Council eventually adopted were among the range of  
7 alternatives that were before the public and discussed at workshops and in staff reports.<sup>127</sup> These  
8 workshops were advertised.<sup>128</sup> We find that adequate, if not ample, opportunity for public  
9 participation was provided . While RCW 36.70A.140 allows for an abbreviated process for  
10 compliance actions, the County's process was not abbreviated. The County published a public  
11 participation process and followed it for eight months.  
12

13  
14 The text of the ordinance that was adopted was similar to the September 1, 2005 version of the  
15 ordinance presented at workshops and at the Planning Commission hearing, as well as the version  
16 that accompanied the notice of the final public hearing.<sup>129</sup> While we agree with the Petitioners that  
17 providing a rationale in public notices and in the body or recitals of land use ordinances adopted  
18 according to the GMA would be an useful addition to the public process for all the reasons given by  
19 the Petitioners, we can find no explicit or implicit requirement that this is required by the RCW  
20 36.70A.140. The Board cannot prescribe a solution that might be better, but can only find  
21 compliance or noncompliance.  
22

23 **Conclusion:** Petitioners have not carried their burden of proof that the County's failure to provide a  
24 rationale for the changes to the Planning Commission's recommendations either in the body of the  
25 Ordinance 7-2006 or in the public notice for the final public hearing on June 6, 2006 does not comply  
26 with RCW 36.70A.130(1)(b) or RCW 36.70A.140.  
27

28 Issue 26: Did the County through the adoption of Ordinance 7-2006, Section 6, violate RCW  
29 36.70A.370 and RCW 36.70A.140, by failing to show in the record why 12 percent was chosen as  
30 the number of detached accessory dwelling units allowed in a given year, why there are no detached  
31

32 <sup>127</sup> Record at 000262 at 3, 000311, 000349

<sup>128</sup> Record at 000270, 000271

<sup>129</sup> Record at 00064, Legal Advertisement for June 6, 2006 Public Hearing  
COMPLIANCE ORDER AND FINAL DECISION AND ORDER  
Case Nos. 03-2-0003c; 06-2-0024c  
February 12, 2007  
Page 52 of 76

1 ADUs allowed on lots less than one acre, why there are no detached ADUs allowed on lots less than  
2 five acres in the shoreline, why there are limitations on proximity of ADUs to a principal residence,  
3 and why there is a prohibition of rentals of ADUs? (John Evans, 06-18)

4 Position of the Parties

5 Petitioner John Evans contends that the County has failed to demonstrate that the extent and nature  
6 of the regulations were necessary for compliance with the Growth Board order and the GMA. He  
7 maintains that a fundamental tenet of the GMA and its public participation program requirements is  
8 that local governments be able to “show their work”; he alleges that the County has failed to do that  
9 here.. Because regulations are actions taken by local government that limit existing rights of citizens  
10 from what they have previously been allowed, citizens have a right to expect that the government to  
11 show the reason behind new regulations.<sup>130</sup>  
12

13 The County responds that all the various issues that Petitioner Evans raises were addressed  
14 throughout the public process in staff reports, previous studies, and discussions.<sup>131</sup>  
15

16 Board Discussion

17 RCW 36.70A.370 requires the State Attorney General to establish a process to assist state agencies  
18 and local government in evaluating proposed regulations to assure that those actions do not result  
19 in a regulatory takings of public property. It does not require that the local jurisdiction give its  
20 reasons for every aspect of the regulations in the ordinance itself.

21 Petitioner Evans asserts that the County did not “show its work” and should have done so when it  
22 adopted restrictions on detached ADUs. In a similar situation, in Whatcom County, the Board held:

23 While it is true that the Act imposes on the County the obligation to “show its work” in some  
24 contexts, such as in the creation of its urban growth areas, the GMA does not require the  
25 County to demonstrate that it harmonized all of its planning documents when it undertakes  
26 an amendment of them. This does not mean that the County is free to enact legislation that  
27 is inconsistent with the requirements of the GMA and its own planning policies; it just means  
28 that the burden is on any petitioners to show that the inconsistency exists.<sup>132</sup>  
29  
30

31 <sup>130</sup> Petitioner’s Prehearing Brief at 4

32 <sup>131</sup> San Juan’s Prehearing Brief at 21

<sup>132</sup> *Cal Leenstra v. Whatcom County*, WWGMHB Case No.03-2-0011 (Final Decision and Order, September 26, 2003) at 14 and 15.

1 The “show your work” requirement arises when the GMA expressly requires the local jurisdiction to  
2 undertake particular foundation analysis prior to adopting a regulation or policy. It arises in the  
3 context of the creation of UGA boundaries, for instance, so that a reviewing growth board can  
4 determine whether “areas and densities sufficient to permit the urban growth that is projected to  
5 occur in the county or city for the succeeding twenty-year period” forms the basis for those  
6 boundaries, as required by RCW 36.70A.110(2). Another example arises for limited areas of more  
7 intensive rural development (LAMIRDs) under RCW 36.70A.070(5)(d). Because the logical outer  
8 boundaries of such LAMIRDs must reflect, among other things, the state of development in those  
9 areas as of July 1, 1990, the counties must “show their work:” so that that assessment may be  
10 evaluated. The GMA does not impose a generalized requirement to explain the rationale for every  
11 comprehensive plan amendment, although the wise jurisdiction will often ensure that that is done to  
12 avoid unnecessary challenges.

14 As a matter of public participation as we discussed in the issue directly above, the record shows that  
15 these amendments were the subject of workshops and hearings and discussed with at those noticed  
16 meetings with the public. That is what RCW 36.70A.140 requires.

18 **Conclusion:** Petitioner has not carried his burden of proof pursuant to RCW 36.70A.320 (2) to  
19 demonstrate that County has not complied with RCW 36.70A.370 or RCW 36.70A.140 by failing “to  
20 show its work”.

22 **G. Shoreline Management Act**

23 Issue 30: Did the passing of Ordinance 7-2006 violate the Shoreline Management Act, RCW  
24 90.58.130 and RCW 36.70A.480(1) by amending the County’s Shoreline Master Program without  
25 proper notification and adoption process? (Wanda Evans, 6-17, Manning et al., 06-15c)

26 Issue 31: Did the passing of Ordinance 7-2006, Section 18.40.240 G(4) (c) violate WAC 173-26-100  
27 (1) and (2), RCW 90.58.090 because no notice was given that Ordinance 7-2006 amended  
28 Shoreline Density? (Wanda Evans, 06-17)

29 Position of the Parties

30 With regard to Issue 30, Petitioner Wanda Evans argues that San Juan County failed to provide the  
31 proper notice and review opportunity to the Department of Ecology as prescribed by the statute. As  
32 to Issue 31, she argues that the County expanded the adoption of new regulations and controls

1 beyond what was necessary to respond to this Board's prior order, and that the proper public  
 2 process was not followed. Petitioner does not provide detailed argument or cite to any prior court or  
 3 Board opinions in support of her position.

4  
 5 The County replies that, because Ordinance 7-2006 adopts uniform rules for ADUs throughout the  
 6 County, it was not necessary to follow the procedure for amendments to its Shoreline Master  
 7 Program. The County argues that the parcel size limitation of 18.40.240 G(4) (c) pertains generally  
 8 to the construction of detached ADUs; just as it is not necessary to amend the Shoreline Master  
 9 Program SMP for a change to zoning in shoreline jurisdiction, it was not necessary when it adopted  
 10 a generalized ADU siting ordinance.

11  
 12 Board Discussion

13 There is only one section of Ordinance 7-2006 that appears to have the potential to affect the  
 14 establishment of ADUs in lands subject to the County's Shoreline Management Program. Section  
 15 18.40.240 G(4) (c) provides:

16 **The minimum parcel size for the construction of a detached accessory dwelling unit is**  
 17 **five acres for any parcel with waterfront.** 10 acres for parcels located in the agricultural  
 18 district, and 20 acres for parcels located in the forest district and one acre for all parcels  
 19 located in a rural land use district. This restriction does not apply to parcels located in urban  
 20 growth areas or activity centers. (emphasis added).

21 Aside from this provision affecting the placement of ADUs on parcels with waterfront, there is no  
 22 reference or other connection between Ordinance 7-2006 and San Juan County's SMP. The relation  
 23 of the County's ADU ordinance to the County's SMP exists solely in that Ordinance 7-2006  
 24 establishes a 5 acre minimum parcel size for the placement of lots that have waterfront, and that  
 25 therefore are also regulated by the SMP.

26 This Board has previously held that "a change in zoning does not *de facto* amend the SMP."  
 27 *Storedahl & Sons, v. Clark County*, WWGMHB 96-2-0016 (Order on Motion for Reconsideration,  
 28 9/15/97). In that case this Board noted that the Clark County Code provided that designated  
 29 shoreline areas of the County are "to be combined with zoning that has been applied to such areas."  
 30 Under the Clark County legislative scheme then under review, the designated shoreline areas and  
 31 the SMP regulations, were subject to and independent of, the zoning districts established by Clark  
 32

1 County's GMA actions. A similar legislative scheme is in place in San Juan  
2 County Code (SJCC) 18.50.010 C<sup>133</sup>.

3  
4 SJCC section 18.50.020 A. provides in part: "If a conflict occurs between this chapter and other  
5 sections of this code, this chapter shall prevail." In addition, SJCC 18.50.010 C. 3. provides, in part,  
6 "Unless specifically provided otherwise, in the event that provisions of the Shoreline Master Program  
7 conflict with other applicable state or local policies or regulations, the SMA and Shoreline Master  
8 Program shall control. Where the Shoreline Master Program is more restrictive than other applicable  
9 state or local policies or regulations, the SMA and Shoreline Master Program shall control." Thus,  
10 whatever restrictions the SMP placed on ADU's prior to the adoption of Ordinance 7-2006 are still in  
11 place.  
12

13  
14 **Conclusion:** The County's adoption of Ordinance 7-2006 was not an amendment of the County  
15 SMP. Whatever regulations the SMP imposed on construction in shoreline jurisdiction prior to the  
16 adoption of Ordinance 7-2006 remain unaltered. We therefore conclude that the County was not  
17 required to comply with the notice and adoption procedures applicable to an amendment of its SMP.  
18

#### 19 H. State Environmental Policy Act (SEPA)

20 Issue 34: Did the County violate WAC 197-11-230 by conducting a SEPA process for the Ordinance  
21 that was reviewed by the Planning Commission, and by not conducting a new SEPA process for the  
22 new ordinance that was adopted by the County Council? (John Evans, 06-17, Wanda Evans, 06-18  
23 John Evans)

24 Issue 36: Is the SEPA Threshold Determination of DNS noncompliant with RCW 43.21C and the  
25 SEPA Rules, Chapter 197-11-060, -080, and -330 WAC? (Ludwig, 06-24)

26 Issue 37: Was the environmental evaluation and analysis required by the SEPA rules adequate and  
27 compliant with RCW 43.21C and Chapter 197-11 -030 and -031 WAC? (Ludwig, 06-24)

#### 28 Positions of the Parties

##### 29 **Petitioners' Positions**

30 Both Petitioners Wanda Evans and Stephen Ludwig argue that the County failed to conduct a proper  
31 SEPA process. Wanda Evans points out that the SEPA checklist was dated April 5, 2006, while the  
32

---

<sup>133</sup> Chapter 18.50 of the San Juan County Code is the County's Shoreline Management Program.

1 County Council did not propose the changes that it eventually adopted until April 25, 2006.<sup>134</sup>  
2 Petitioner Ludwig describes the regulations for which the checklist was prepared as regulations that  
3 prohibited detached ADUs in parcels of less than 10 acres citing answers to Questions one and two  
4 on the checklist. For these reasons, Petitioner Ludwig maintains that no threshold determination  
5 was made for the Ordinance that was eventually adopted as required by 43.21C.030(2)(c) –(e) and  
6 WAC 197-11-310 and -330.<sup>135</sup>

7  
8 Petitioner Ludwig contends that not only was the process conducted improperly, but the DNS issued  
9 by the County was clearly erroneous. He says that the impacts from the amendments to the  
10 County's ADU regulations adopted by Ordinance 7-2006 are significant for the following reasons:  
11 (1) the amendments allow for a near doubling of the number of dwelling units in SJC, (2) the County  
12 has already experienced an increasing level of nitrates in groundwater caused from drain fields in  
13 several areas, (3) the County's own consultant has recommended that all of San Juan County be  
14 designated a critical aquifer recharge area, and (4) all the County's shorelines are critical fish and  
15 wildlife habitat areas.<sup>136</sup>

16  
17 **County's Position**

18 The County replies that amendments to the County's ADU regulations adopted by Ordinance 7-2006  
19 reduce the environmental impacts from those caused by the regulations adopted by Ordinance 21-  
20 2002. The County maintains that the threshold determination for Ordinance 21-2002 survived a  
21 previous challenge, where the potential impacts were thoroughly discussed. These documents were  
22 clearly referenced and incorporated in the April 5, 2006 Determination of Non-significance (DNS).<sup>137</sup>

23  
24 Board Discussion

25 The April 17, 2003 Final Decision and Order found that the DNS issued for Ordinance 21-2002 that  
26 incorporated the Final ADU report was not clearly erroneous.<sup>138</sup> Both Petitioners Wanda Evans and  
27 Stephen Ludwig are correct in their assertion that the DNS was prepared for the planning  
28 commission's version of ADU amendments that did not allow for detached ADUs. Petitioners  
29

30  
31 <sup>134</sup> Petitioner's Prehearing Brief at 4.

<sup>135</sup> Petitioner's Prehearing Brief at 5 – 7.

<sup>136</sup> Ibid at 7

<sup>137</sup> San Juan County's Prehearing Brief at 23 -24.

<sup>138</sup> Corrected Final Decision and Order at 34.



1 contend that the County should have issued a new threshold determination when the County  
2 Council amended the Planning Commission's recommendation that allowed for no detached ADUs,  
3 eliminated many of the restrictions on placement of ADUs and changed the ERU requirement. WAC  
4 197-11-600 (2)(b) says this about the County's obligation in this situation:

5 For DNSs and EISs, preparation of a new threshold determination or supplemental EIS is  
6 required if there are: i) Substantial changes to a proposal so that the proposal is likely to  
7 have significant adverse environmental impacts (or lack of significant adverse impacts, if a  
8 DS is being withdrawn); or (ii) New information indicating a proposal's probable significant  
9 adverse environmental impacts. (This includes discovery of misrepresentation or lack of  
10 material disclosure.) **A new threshold determination or SEIS is not required if probable  
11 significant adverse environmental impacts are covered by the range of alternatives  
12 and impacts analyzed in the existing environmental documents.**

11 WAC 197-11-600(2)(b)(emphasis added).

12 The April 5, 2006 DNS was accompanied by an environmental checklist clearly incorporates the  
13 environmental checklist that was issued for Ordinance 21-2002.<sup>139</sup> RCW 43.21C.030 allows the  
14 incorporation of existing documents:

15 Lead agencies are authorized to use in whole or in part existing environmental documents for  
16 new project or nonproject actions, if the documents adequately address environmental  
17 considerations set forth in RCW 43.21C.030. The prior proposal or action and the new  
18 proposal or action need not be identical, but must have similar elements that provide a basis  
19 for comparing their environmental consequences such as timing, types of impacts,  
20 alternatives, or geography.

21 While the changes that allowed a limited number of detached ADUs would most likely have had  
22 more environmental impacts than the Planning Commission's version, the Council's changes would  
23 not have caused more environmental impacts than Ordinance 21-2002 which did not include any  
24 limitations on ADUs. Those impacts were analyzed and commented upon in the Final ADU Report  
25 that was incorporated into the DNS that was issued for Ordinance 21-2002.<sup>140</sup> The April 17, 2003  
26 Corrected Final Decision and Order found that the DNS issued for Ordinance 21-2002 that  
27 incorporated the Final ADU report was not clearly erroneous.<sup>141</sup>

30 \_\_\_\_\_  
31 <sup>139</sup> Exhibit C, attached Ludwig Petitioner's Brief at 2.

32 <sup>140</sup> .Exhibit C, DNS (August 13,2002) attached to San Juan County, Motion to Rescind Invalidity and Find  
Compliance (Accessory Dwelling Units)(December 19, 2002)

<sup>141</sup> Corrected Final Decision and Order at 34.

1 Petitioner Ludwig argues that the impacts of the amendments made by Ordinance 7-2006 are  
 2 significant. His argument that the amendments could cause doubling of density were arguments  
 3 made by Petitioners in opposing Ordinance 21-2002 and were analyzed in the accompanying  
 4 environmental documents to Ordinance 21-.2002.<sup>142</sup> The County has a compliant Fish and Wildlife  
 5 Habitat Conservation Critical Area designations and compliant regulations to protect them. The  
 6 rising level of nitrates from some drain fields and recommendations from a County consultant that all  
 7 of San Juan County should be designated a CARA may be new information. However, Petitioner  
 8 Ludwig does not present us sufficient information concerning these allegations to determine whether  
 9 it pertains to the ADU regulation amendments nor does he provide any analysis of how the County's  
 10 current regulations for CARAs are inadequate for protecting these critical areas from the limited  
 11 number of ADUs that will result from the adoption of Ordinance 7-2006.  
 12

13  
 14 An analysis of SEPA compliance for GMA purposes is based upon the same "clearly erroneous"  
 15 standard as established for compliance.<sup>143</sup> Petitioners carry the burden of proof in showing that a  
 16 mistake has been made in issuing the DNS.  
 17

18 **Conclusion:** Therefore, the Board finds that the County was not required to issue a new threshold  
 19 determination pursuant WAC 197-11-600(2)(b) because the environmental impacts caused by the  
 20 Council's changes were not more significant than similar impacts that were previously analyzed by  
 21 the County for Ordinance 21-2002 and incorporated in the April 5, 2006 checklist.  
 22

23 Additionally, these previous environmental documents were challenged and found to be compliant  
 24 by the April 17, 2003 Corrected Final Decision and Order. Our review of the environmental checklist  
 25 issued for the April 5, 2006 DNS and Petitioner Ludwig's arguments does not convince us that a  
 26 mistake was made in issuing the April 5, 2006 DNS. Petitioner has not sustained his burden of proof  
 27 pursuant to RCW 36.70A.320(2).  
 28

29 **I. Water Systems**  
 30

31  
 32 <sup>142</sup> Friends of San Juans, Opposition to San Juan County's Motion to Rescind Invalidity and Find Compliance  
 and Request for SEPA Review (January 1, 2003) at 9.

<sup>143</sup> *Durland v. San Juan County*, WWGMHB Case No. 99-2-0010c (May 2001).

1 Issue 14: Does the requirement for one equivalent residential unit (ERU) of water for any detached  
2 ADU contained on Ordinance 7-2006, Section 9, mislead the public process and is it contrary to the  
3 County's stated goals, as stated in the Ordinance's recitals, in violation of RCW 36.70A.020 (4) and  
(7), RCW 36.70A.540, and RCW 36.70A.011? (Gutschmidt, 06-20)

4 Issue 39: Does the requirement contained in Ordinance 7-2006 for one additional Equivalent  
5 Residential Unit (ERU) of water for an detached ADU violate RCW 36.70A.130(1)(d), RCW  
6 36.70A.070 and 36.70A.040(5) because it is inconsistent with the goals and policies of the  
7 Comprehensive Plan Section 4.2.B.1.6 and Development Regulations (UDC Section 18.60.020)  
8 contrary to state policy and water regulations that are regulated by WAC 246-290-100-4 and WAC  
246-290-100-4(b)(i) and (ii)? (Nelson, 06-20, Wanda Evans, 06-17).

9 Positions of the Parties

10 **Petitioner's Position**

11  
12 Petitioner Ralph Gutschmidt contends that requiring one ERU of water for a detached ADU is  
13 contrary to Ordinance 7-2006's stated goals, will eliminate ADUs by doubling the water requirement,  
14 and misleads the public into believing that these requirements will provide affordable housing for  
15 moderate income people. Petitioner Gutschmidt also claims that the County failed to consider  
16 property rights when it imposed doubling the water requirements for detached ADUs and imposed  
17 an impossible burden of proof on applicants that detached ADUs will not interfere sensitive areas  
18 and open spaces.

19 Petitioner Wanda Evans asserts that the County changed the "water buildout" within water systems'  
20 service areas without consideration of an individual water system's plan. This, she claims violates  
21 RCW 36.70A.130(1)(d).  
22

23 **County's Position**

24 The County argues that no evidence in the record exists to support to Petitioner Gutschmidt's  
25 contention that requirement for one ERU for a detached ADU will eliminate a large number of  
26 affordable ADUs. Even if this new requirement makes one type of housing less affordable, the  
27 County maintains that it is up to the County to reconcile the GMA's affordable housing goal with  
28 other GMA goals. The County says that the requirement rose from the County Council's concern  
29 from the onset of the public participation process that a detached ADU would operate more like an  
30 independent living unit. The County says that RCW 19.27.097 gives it the responsibility to assure  
31  
32

1 that adequate water is available for planned development uses and authorizes the Council's action  
2 to require one ERU of water for detached ADUs.<sup>144</sup>

3  
4 The County asserts that its comprehensive plan does not prohibit the County Council from taking  
5 this action, and this action does not interfere with WAC provisions governing private water  
6 systems.<sup>145</sup>

7  
8 Board Discussion

9 Even though both the Petitioner Gutschmidt and the County's argument on Issue 14 address the  
10 County's alleged violation of the property rights goal of the GMA, the issue statement does not  
11 allege a violation of the property rights goal (RCW 36.70A.020(6), but violations of RCW  
12 36.70A.020(7) (Permitting) and the RCW 36.70A.020(4) (Housing). Because the issue statement  
13 does not allege violations of the property rights goal, the Board cannot address it. Pursuant to RCW  
14 36.70A.290(1), the Board is limited to issues that were raised in the issue statement:

15 The Board shall not issue advisory opinions on issues not presented to it in the statement of  
16 issues, as modified by the prehearing order".  
17 The Presiding Officer issued a prehearing order to which Petitioners had seven days to respond.  
18 Several Petitioners, but not Mr. Gutschmidt, did respond with objections and their issues were  
19 amended. On September 18, 2006, the Presiding Officer entered an Amended Prehearing Order  
20 and it does not contain a claim that the requirements for an ERU for a detached ADO violates Goal 6  
21 of the GMA (RCW 36.70A.020(6)). It is therefore not before the Board.

22  
23 Petitioner Gutschmidt contends that the County has mislead the public because the County's  
24 restrictions on detached ADUS will not let the County realize some of the goals expressed in  
25 Ordinance 7-2006. Ordinance 7-2006 recites objectives of the legislation, including goals to provide  
26 rental income, to add affordable housing to existing housing, and to make housing available to  
27 moderate income people who are having trouble finding homes. Petitioner Gutschmidt says the  
28  
29  
30  
31

32  

---

<sup>144</sup> San Juan County's Prehearing Brief at 16 – 18.

<sup>145</sup> San Juan County's Prehearing Brief at 16 and 17.

1 conflict between the stated goals in Ordinance 7-2006 and what it actually allows violates the  
2 housing and permitting GMA goals, as well RCW 36.70A. 011.<sup>146</sup>

3  
4 However, in these issues, Petitioners allege that violations of Goals 4 and 7 of the GMA arise from  
5 the imposition of a requirement for a full ERU of water availability to a permitted detached ADU.  
6 There is simply nothing before the Board to show that this requirement will have the impact of  
7 interfering with the County's efforts to promote affordable housing or to provide a timely, fair and  
8 predictable permitting process.

9  
10 In Issue Statement 39 Petitioner Wanda Evans claims that requiring one ADU for water is not  
11 consistent with Comprehensive Plan Section 4.2.B.1.6 and UDC Section 18.60.020. This  
12 inconsistency in turn, she claims, does not comply with RCW 36.70A.130(4) which requires  
13 comprehensive plan and development regulation amendments to be consistent with the County's  
14 existing comprehensive plan and development regulations.<sup>147</sup>

15  
16 The Board's examination of Comprehensive Plan Section 4.2.B.1.6 and UDC Section 18.60.020  
17 finds that both this section of the Comprehensive Plan and the section of the Unified Development  
18 Code authorize the County to ensure that each development permit has adequate and available  
19 water and establishes methods for doing this. We find no inconsistency between the requirements  
20 of one ERU of water for a detached ADU and the cited comprehensive plan policy and development  
21 regulation.<sup>148</sup>

22  
23 Finally our examination of WAC 246-290-100-4 and WAC 246-290-100-4(b)(i) and (ii) confirm that  
24 these WACs set out the requirements for water system plan. They do not set the parameters for  
25 cities and counties to establish the adequacy of water for building permits. Additionally, determining  
26 compliance with these requirements of the WAC is not within the jurisdiction of a growth  
27 management hearings board. See RCW 36.70A.280.

28  
29  
30 <sup>146</sup> Prehearing Brief at 5-7. Issue 14 alleges a violation of RCW 36.70A.570, but Petitioner's Brief does not  
offer any arguments on how Ordinance 7-2006 violates this statute.

31 <sup>147</sup> Petitioner's Prehearing Brief at 4 and 5. Issue Statement 39 contains the allegation that the requirement  
32 for one ERU is not consistent with RCW 36.70A.070 and RCW 36.70A.040 (5), however Petitioner's  
Prehearing Brief does not address this violation.

<sup>148</sup> Comprehensive Plan, Element 4, Water Resources at 2 and UDC Section 18.60.20(A) – (C) at 1 – 2.

1  
2  
3  
4  
5  
6  
7  
8  
9  
10  
11  
12  
13  
14  
15  
16  
17  
18  
19  
20  
21  
22  
23  
24  
25  
26  
27  
28  
29  
30  
31  
32

**Conclusion:** Based on the foregoing, Petitioners have not carried their burden of proof that the amendment to require one ERU of water for an attached ADU violates RCW 36.70A.020(4) and (7), RCW 36.70A.570, RCW 36.70A. 011, RCW 36.70A.130(4), and RCW 36.70A. 070. The Board finds that it has no jurisdiction to determine compliance with WAC 246-290-100-4 and WAC 246-290-100-4(b)(i) and (ii) pursuant to RCW 36.70A.280(1).

**J. Invalidity**

Petitioner's Position

Petitioner Ludwig asks that the Board impose invalidity and request that the Governor impose sanctions because the County has disregarded the consequences of its noncompliance and has been out of compliance for at least seven years.<sup>149</sup>

Board Discussion

The only provision of the amendments established by Ordinance 7-2006 that the Board has found noncompliant is SJCC 18.40. 240(G) (4)[it is ALL of 18.40.240(G)(4)]. Prior to imposing a determination of invalidity, the Board must make a finding of noncompliance. RCW 36.70A.302(1)(a). Therefore, the only provision of Ordinance 7-2006 that is subject to an invalidity determination is SJCC 18.40. 240(G) (4).

The Board has held that it will impose invalidity when the continuance of the regulation would interfere with the County's ability to properly plan during the remand period.<sup>150</sup> Here, the limited number of potential detached ADU permits that might be issued during the remand period makes it unlikely that continued validity of SJCC 18.40. 240(G) (4) will substantially interfere with the fulfillment of the goals of the GMA generally and Goal 2 specifically. However, if the County does not act to achieve compliance on this provision within the remand period, the Board would consider a properly supported motion for invalidity at that time.

<sup>149</sup> Ludwig, Prehearing Brief at 8.

<sup>150</sup> See *Lake Cavanaugh Association v. Skagit County*, WWGMHB 04-2-0011 (Order on Dispositive Motion , September 21, 1994), *Butler, et. al v. Lewis County*, WWGMHB Case No. 99-2-0027c and *Panesko v. Lewis County*, WWGMHB Case No. 00-2-0031c (Order Finding Noncompliance and Imposing Invalidity, February 13, 2004)

1 Conclusion: As long as the County acts within the remand period set in this order, the Board finds it  
2 unlikely that the continued validity of SJCC 18.40. 240(G) (4) will substantially interfere with the  
3 fulfillment of the goals of the GMA. Therefore, we decline to enter a finding of invalidity at this time.  
4 As for sanctions, the Board finds that Ordinance 7-2006 represents good progress in bringing San  
5 Juan County's detached ADU regulations into compliance with the GMA. There is no basis for  
6 seeking sanctions at this time.  
7

8 **VII. FINDINGS OF FACT**

- 9
- 10 1. San Juan County is located west of the crest of the Cascade Mountains and is required to  
11 plan according to RCW 36.70A.040.
  - 12 2. Margaret Manning and Timothy Blanchard (Case No. 06-2-00013), Donna Gavora (Case No.  
13 06-2-0015), Wanda Evans (Case No.06-2-0017), John Evans (Case No.06-2-0018), Brian  
14 and Orgelina Wiese(Case No. 06-2-0019), Ralph Gutschmidt (Case No. 06-2-0020), James  
15 Nelson (Case No. 06-2-0021), and Stephen Ludwig (Case No. 00-2-0024) filed timely  
16 Petitions for Review.
  - 17 3. Case No. 06-2-0013 and Case No. 06-2-0015 were consolidated as Case No. 06-2-0015c.  
18 Case No. 06-2-0015c was consolidated with Case Nos. 06-2-0017, 06-2-18. 06-2-0019, 06-  
19 2-0020. 06-2-0021, and 06-2-0024 and captioned as James Nelson et al v. San Juan  
20 County, Case No. 06-2-0024c..
  - 21 4. Friends of San Juans was an original petitioner in Case No. 03-2-0003c and was granted  
22 intervention in Case No. 06-2-0024c.
  - 23 5. All the Petitioners and Intervenor Friends of San Juans participated orally and in writing in  
24 the process to adopt Ordinance 7-2006.
  - 25 6. San Juan County adopted Ordinance 7-2006 on June 8, 2006.
  - 26 7. Ordinance 7-2006 was adopted to achieve compliance with the Board's Final Decision and  
27 Order/Compliance Order in WWGMHB Case No. 03-2-0003c. That decision found that the  
28 County's prior ADU regulations allowed unlimited detached ADUs throughout rural and  
29 resource lands without counting those detached ADUs as additional residential density. The  
30 Board found this violated GMA requirements for rural densities (RCW 36.70A.070(5)), GMA  
31 prohibitions against creating urban growth in rural and resource lands (RCW 36.70A.110(1))  
32 and the GMA's goal for reduction of sprawl (RCW 36.70A.020(2)) and conservation of  
resource lands (RCW 36.70A.020(8)).
  8. The Board rescinded its determination of invalidity placed on the County's provisions  
regulating detached ADUs on August 18, 2006 in its Order Lifting Invalidity, based on the  
amendments adopted by Ordinance 7-2006.
  9. The chief petitioner in the compliance case (WWGMHB Case No. 03-2-0003c), was Friends  
of San Juans (Friends). Friends no longer challenges the compliance of the County's ADU  
development regulations with the goals or requirements of the Growth Management Act  
(GMA) and now supports a finding of compliance.
  10. Pursuant to SJCC 18.20.010, an "accessory dwelling unit (ADU)" is defined as a living area  
that is accessory to the principal residence, located on the same lot, and that provides for  
sleeping quarters, kitchen, and sanitation facilities.

- 1 11. Pursuant to SJCC 18.20.040, a “detached ADU” is defined as an ADU that is physically
- 2 distinct from the principal residence.
- 3 12. The amendments enacted by Ordinance 7-2006 count a detached ADU as a unit of density
- 4 in rural and resource lands unless allowed pursuant to an ADU permit. SJCC 18.40.240(A).
- 5 13. SJCC 18.40.240 establishes a program to allow a small number of permits for detached
- 6 ADUs in resource and some rural lands annually.
- 7 14. Detached ADUs are limited to no more than 1,000 square feet in living area. SJCC
- 8 18.40.240(F)(1).
- 9 15. SJCC 18.240(F)(4) requires the accessory dwelling unit to be owned by the owner of the
- 10 principal residence.
- 11 16. New SJCC 18.40.240(G)(1)(b) provides that outside of the boundaries of activity centers and
- 12 urban growth areas, the number of detached ADU permits in any calendar year shall not
- 13 exceed 12 percent of the total number of building permits for new principal residences issued
- 14 for the previous calendar year outside the boundaries of activity centers and urban growth
- 15 areas.
- 16 17. New SJCC 18.40.240 (G)(2) restricts the maximum distance between the
- 17 closest vertical walls of the main house and any detached accessory dwelling unit to no
- 18 more than 100 feet, unless the 100 feet distance would result in a greater impact on the
- 19 open space features of the property.
- 20 18. SJCC 18.40.240(G)(3) requires the location impacts to “avoid or minimize
- 21 intrusion on the most sensitive open-space features of the site” including existing orchard,
- 22 meadows an pasture areas; ridgelines and contrasting edges between landscape types
- 23 unbroken by structures; rolling, open or steep open slopes, and critical areas.
- 24 19. Ordinance 7-2006 amends SJCC 18.40.240 to provide that an accessory
- 25 dwelling unit shall use the same driveway, septage[~~sic~~]/sewer system, and water system as
- 26 the principal residence.
- 27 (SJCC 18.40.240(F)(3)).
- 28 20. The requirement for a shared septic system is new to this version of the ADU development
- 29 regulations.
- 30 21. The absolute number of ADU permits, based on historical numbers of building permits issued
- 31 outside of activity centers and urban growth areas, is estimated to be about 15 per year. Of
- 32 that amount, 1/6<sup>th</sup> of the ADU permits are allocated to conversions of existing structures that
- have been legal for at least 5 years.
22. The Official Maps of the County’s Comprehensive Plan establish rural densities at one
- dwelling unit per five acres and one dwelling unit per ten acres. These rural densities have
- been found compliant with RCW 36.70A.070(5)(b) and (c).
23. San Juan County’s comprehensive plan describes its rural character as:
- “...Rural lands are intended to retain the pastoral, forested, and natural landscape qualities
- of the islands while providing people with choices for living environments at lower densities
- or use intensities than those in Activity Centers”.
24. San Juan County’s development code further describes rural character as: “...a quality of
- landscape dominated by pastoral, agricultural, forested and natural areas interspersed with
- single-family homes and farm structures....”
25. San Juan County’s isolation, recognition as a tourist destination, historic use of ADUs for
- vacationing family members or as a vacation residence before a main house is built, and
- rural lot development pattern are unique characteristics.



- 1 26. Given the number of potential parcels upon which detached ADUs may be constructed and
- 2 the limitations on their size, location, and ownership, an annual limit of approximately 15 of
- 3 such permits is unlikely to disturb the existing, compliant scheme of rural densities, that is,
- 4 densities of 1 dwelling unit per 5 acres or 1 dwelling unit per 10 acres.
- 5 27. The limited number of detached ADU permits coupled with the limitations on location,
- 6 ownership, utilities and impact on the open-space features of the lot also prevent the
- 7 detached ADU regulations from creating sprawl in rural zones of compliant rural densities.
- 8 28. The small number of such permits issued for detached ADUs in rural and
- 9 resource lands restrains the extent of such development in any one area so it is most likely
- 10 that detached ADU permits will be issued in different locations, rather than establishing a
- 11 pattern of growth.
- 12 29. However, Ordinance 7-2006 also allows detached ADUs to be constructed or converted on
- 13 rural lots that are less than 5 acres in size, if the lots are at least 1 acre in size. (SJCC
- 14 18.40.240 (G)(4)(b)).
- 15 30. The County Comprehensive Plan acknowledges the existence of lots in the RR (rural
- 16 residential) zone that are below 5 acres in size but notes that this is because they were
- 17 established in the 1979 comprehensive plan.
- 18 31. The Comprehensive Plan also encourages combination of existing lots in order to reduce the
- 19 number of dwelling units that may be developed in rural areas "where the existing parcel
- 20 pattern would permit development at a density greater than that established by this Plan and
- 21 the Official Maps".
- 22 32. Where the rural lots are nonconforming (under 5 acres in size), the addition of a second
- 23 residence causes residential uses to predominate over rural uses and to exceed a rural level
- 24 of development.
- 25 33. Allowing an additional detached residence on a nonconforming rural lot is not consistent with
- 26 the County's own plan for rural densities and preservation of rural character.
- 27 34. Intensive residential uses on these substandard rural lots constitute urban growth in rural
- 28 lands.
- 29 35. The County's estimate of 15 detached ADUs annually applies to all rural and resource lands,
- 30 not just to resource lands.
- 31 36. In resource lands, the location, size and ownership requirements for detached ADUs
- 32 together with the limit on numbers of such detached ADUs minimize the conversion of
- resource lands to non-resource purposes, and do not create an incompatible use.
- 37 37. No evidence exists in the record that San Juan County has elected to
- create an affordable housing incentive program pursuant to RCW 36.70A.540.
- 38 38. No Petitioner cites to any portion of the CTED recommendations for providing ADUs that the
- County is alleged to have violated.
- 39 39. No evidence has been presented that either Ordinance 7-2006's limitations on
- attaching ADUs to accessory buildings or limiting building permits for detached ADUs to 12
- percent of the annual residential permits in rural and resource lands exceed the scope of
- local flexibility allowed by RCW 43.63A.215.
- 40 40. Petitioners have not offered any evidence that the County's ADU regulatory scheme will
- reduce the affordability of housing in San Juan County.
- 41 41. Petitioners have not demonstrated that the limitation on detached ADUs in rural and resource
- lands will have a significant impact upon economic development in the San Juan Islands.
- 42 42. SJCC 18.40. 240 (G)(3) provides criteria to use when issuing a building permit for a

- 1 detached ADU. Building Permits are issued on a case by case basis.
- 2 43. The County promptly published guidelines on how to apply for an ADU permit and allows for
- 3 telephone reservations for ADU permits to help make the permit system more accessible for
- 4 those who must travel long distances to the permit office and nonresident applicants.
- 5 44. The County adopted a public participation program specifically for consideration of the
- 6 amendments to its ADU regulations. The public participation program included workshops,
- 7 hearings before the planning commission, opportunities for written comment, and public
- 8 hearings before the County Council.
- 9 45. The County followed its adopted public participation program for eight months.
- 10 46. The County held several public workshops and three public hearings
- 11 47. The record shows that there was full public participation here and this was not an
- 12 abbreviated process
- 13 48. The Commissioners developed a September 1, 2005 draft version of amendments to the
- 14 County's ADU regulations that allowed for a limited number of detached ADUs subject to
- 15 certain restrictions. These or similar recommendations were the subject of several
- 16 workshops, as well as hearings before the Planning Commission and a County Council
- 17 public hearing on June 6, 2006.
- 18 49. Letters in the record from Friends indicate that it supported the September 1, 2005 County
- 19 draft recommendations that allowed for an exception to requiring detached ADUs as a unit of
- 20 density in rural and resource lands with strict conditions.. Friends also supported the
- 21 Planning Commission's recommendations that detached ADUs should not be allowed in rural
- 22 or resource lands without counting them as a unit of density.
- 23 50. The County invited written public comments on the draft amendments presented at the June
- 24 6, 2006 public hearing, as well as allowing public testimony.
- 25 51. The subject of the Board's remand order was the County's ADU regulations.
- 26 52. The subject of Ordinance 7-2006 is an amendment to the County Code concerning ADU
- 27 construction and permitting.
- 28 53. The amendments that the County Council eventually adopted were among the range of
- 29 alternatives that were before the public and discussed at workshops and in staff reports. .
- 30 54. The recommendations in the September 1, 2005 draft were discussed at workshops, before
- 31 the planning commission, and at the June 6, 2006 public hearing. These recommendations
- 32 were very similar to those eventually adopted by the County Council.
- 55. The County's adoption of Ordinance 7-2006 affects lots in the shoreline that seek to add a detached ADU but did not amend its shoreline master program.
- 56. The April 5, 2006 Determination of Nonsignificance was accompanied by the environmental checklist which clearly incorporates the environmental documents that were issued for Ordinance 21- 2002.
- 57. The changes to Ordinance 21-2002 adopted by Ordinance 7-2006 are not likely to cause more environmental impacts that the regulations adopted by Ordinance 21-2002, since the regulations in Ordinance in 21-2002 did not include any limitations on ADUs.
- 58. Comprehensive Plan Section 4.2.B.1.6 and UDC Section 18.60 authorize the County to ensure that each development permit has adequate and available water.
- 59. Any Finding of Fact hereafter determined to be a Conclusion of Law is hereby adopted as such.

**VIII. CONCLUSIONS OF LAW**

- 1
- 2
- 3 A . The Board has jurisdiction over the parties and subject matter of this consolidated case.
- 4 B. The petitions were timely brought and the petitioners have standing to raise the issues in their
- 5 petitions for review (now consolidated).
- 6 C. The petitions challenge the County’s adoption of San Juan County Ordinance 7-2006.
- 7 D. Ordinance 7-2006, as it applies to permitted detached ADUs in existing, compliant rural zones,
- 8 does not alter the existing compliant residential densities in those zones to an extent that violates
- 9 RCW 36.70A.070(5).
- 10 E. Ordinance 7-2006, as it applies to permitted detached ADUs in existing, compliant rural zones,
- 11 does not violate the prohibitions against urban growth in rural areas in RCW 36.70A.110(1) or Goal
- 12 2 of the GMA (sprawl reduction) (RCW 36.70A.020(2)).
- 13 F. The regulations that permit a detached ADU to be constructed or converted on a nonconforming
- 14 rural lot of less than 5 acres (SJCC 18.40.240(G)(4)) fail to comply with RCW 36.70A.070(5) by
- 15 expanding the structural intensity in rural zones beyond that which is set out in the County
- 16 comprehensive plan and/or is consistent with the GMA.
- 17 G. SJCC 18.40.240(G)(4) also creates urban growth in rural zones and promotes sprawl, thus not
- 18 complying with RCW 36.70A.110(1) and RCW 36.70A.020(2).
- 19 H. The limited provision for detached ADU permits in resource lands under the strict constraints of
- 20 SJCC 18.40.240(F) and (G)(1),(2) and (3) complies with Goal 8 of the GMA (the natural resource
- 21 industries goal)(RCW 36.70A.020(8)).
- 22 I. The nature and scope of the limitations placed on detached ADUs in rural and resource lands as
- 23 adopted by Ordinance 7-2006 are within the County’s “local flexibility” pursuant to RCW 43.63A.215
- 24 and therefore comply with RCW 36.70A.400.
- 25 J. Ordinance 7-2006 complies with RCW 36.70A.020(4), RCW 43.63A.215, RCW 36.70A.011 and
- 26 RCW 36.70A.540.
- 27 K. Ordinance 7-2006, Section 18.40.240 G(1)(b) and Sections 1, 3,5 of the Ordinance comply with
- 28 RCW 36.70A.020 (7).
- 29 L. The public participation process followed to adopt the amendments to the County’s ADU
- 30 regulations by Ordinance 7-2006 were not clearly erroneous violations of RCW 36.70A.130 (2)(b),
- 31 RCW 36.70A.130(1), or RCW 36.70A.140.
- 32 M. The County’s method of public notification for consideration of its ADU amendments in Ordinance
- 7-2006 complies with RCW 36.70A.035 (1).

1 N. The adoption of Ordinance 7-2006 did not violate the Shoreline Management Act (Ch. 90.58  
2 RCW).

3 O. The adoption of Ordinance 7-2006 did not violate the State Environmental Policy Act (SEPA) (Ch.  
4 43.21C RCW).

5 P. The Board has no jurisdiction over the regulation of private water systems or deciding compliance  
6 with WAC 246-290-100-4 and WAC 246-290-100-4(b)(i) and (ii) pursuant to RCW 36.70A.280(1).

7 Q. Any Conclusion of Law hereafter determined to be a Finding of Fact is hereby adopted as such.  
8

9 **IX. ORDER**

10 San Juan County is ordered to bring ICC SJC 18.40.240(G)(4) into compliance with the GMA in  
11 accordance with this decision within 180 days. **Compliance shall be due no later than July 12,**  
12 **2007.** The following schedule shall apply:  
13

14 Compliance Due	July 12, 2007
15 Compliance Report and Index to 16 Compliance Record (County to file 17 and serve on all parties)	July 23, 2007
18 Any Objections to a Finding of 19 Compliance and Record 20 Additions/Supplements Due	August 6,, 2007
21 County's Response Due	August 20, 2007
22 Compliance Hearing (location to be 23 determined)	August 27, 2007

24 Any requests for an extension of the period for compliance must substantiate that compliance could  
25 not reasonably be achieved within the time period set herein and must be filed with the Board no  
26 later than **June 30, 2007.**

27 Entered this 12<sup>th</sup> day of February 2007.

28  
29 \_\_\_\_\_  
30 Holly Gadbow, Board Member

31  
32 \_\_\_\_\_  
Margery Hite, Board Member

1  
2  
3  
4  
5  
6  
7  
8  
9  
10  
11  
12  
13  
14  
15  
16  
17  
18  
19  
20  
21  
22  
23  
24  
25  
26  
27  
28  
29  
30  
31  
32

---

James McNamara, Board Member

Pursuant to RCW 36.70A.300 this is a final order of the Board.

**Reconsideration.** Pursuant to WAC 242-02-832, you have ten (10) days from the mailing of this Order to file a petition for reconsideration. Petitions for reconsideration shall follow the format set out in WAC 242-02-832. The original and three copies of the petition for reconsideration, together with any argument in support thereof, should be filed by mailing, faxing or delivering the document directly to the Board, with a copy to all other parties of record and their representatives. **Filing means actual receipt of the document at the Board office.** RCW 34.05.010(6), WAC 242-02-330. The filing of a petition for reconsideration is not a prerequisite for filing a petition for judicial review.

**Judicial Review.** Any party aggrieved by a final decision of the Board may appeal the decision to superior court as provided by RCW 36.70A.300(5). Proceedings for judicial review may be instituted by filing a petition in superior court according to the procedures specified in chapter 34.05 RCW, Part V, Judicial Review and Civil

**Enforcement.** The petition for judicial review of this Order shall be filed with the appropriate court and served on the Board, the Office of the Attorney General, and all parties within thirty days after service of the final order, as provided in RCW 34.05.542. Service on the Board may be accomplished in person, by fax or by mail, but service on the Board means **actual receipt of the document at the Board office** within thirty days after service of the final order.

**Service.** This Order was served on you the day it was deposited in the United States mail. RCW 34.05.010(19)

**Appendix A<sup>151</sup>**

In its final decision and order on the consolidated case, the Board found the County's regulations that allowed freestanding accessory dwelling units (ADUs) in rural and resource lands to be noncompliant and invalid. *Friends of San Juans, et al. v. San Juan County*, WWGMHB Case No. 03-2-0003c (Corrected Final Decision and Order, April 17, 2003). Both the County and Petitioners appealed this decision, which was heard in Thurston County Superior Court.

---

<sup>151</sup> For procedural history in this case previous to April 17, 2003, see Order Lifting Invalidity (August 18, 2006) COMPLIANCE ORDER AND FINAL DECISION AND ORDER  
Case Nos. 03-2-0003c; 06-2-0024c  
February 12, 2007  
Page 70 of 76

1  
2 On October 7, 2003, the Board divided the issues in the consolidated case, *Friends of San Juans v.*  
3 *San Juan County*, WWGMHB Case No. 03-2-0003c, because the issues consolidated in these  
4 cases were on two different compliance schedules. The issues regarding ADUs remained in Case  
5 No. 03-2-0003c.<sup>152</sup> The issues regarding the designation of urban growth areas (UGAs) for Lopez  
6 Village and Eastsound were kept in their original case, *Michael Durland v. San Juan County*,  
7 WWGMHB Case No. 00-2-0062c. That case is being heard with *Fred Klein v. San Juan County*,  
8 WWGMHB Case No. 02-2-0008.

9  
10 On October 31, 2003, the Board granted the County an extension of time.

11 On January 9, 2004, the Thurston County Superior Court issued a decision that upheld the Board's  
12 decision on density requirements for freestanding ADUs in rural and resource lands.<sup>153</sup>

13  
14 On January 30, 2004, the County submitted a progress report to the Board. The report stated that  
15 the County has appealed the superior court decision and that the County is not accepting any  
16 applications for freestanding ADUs that do not conform to the Board's April 17, 2003, decision as  
17 modified by the superior court decision.  
18

19 A telephonic hearing was held on May 21, 2004. After the compliance hearing, the County  
20 participated in two mediation sessions with Friends. Neither of these mediation sessions was  
21 successful in resolving the issues. The County requested in its June 21, 2004, letter that the Board  
22 exercise its discretion and not issue an order until the appellate court issues its decision.  
23

24 On June 30, 2004, the Board issued an order finding continuing noncompliance and invalidity and  
25 ordering the County to take official action to comply with the Board's April 17, 2003, order and to  
26 notify the public of that action.  
27

28  
29  
30 <sup>152</sup> ADU issues were originally heard in *Town of Friday Harbor, Fred R. Klein, John M. Campbell, and Lynn*  
*Bahrych, et al. v. San Juan County*, WWGMHB Case No. 99-2-0010c.

31 <sup>153</sup> However, the superior court ruled that the occupants of ADUs in resource lands did not have to be limited  
32 to family members or farm workers as required by the Board's decision and upheld the County's siting  
requirements.

1 On July 9, 2004, the Board received Petitioners' Motion for Clarification or Reconsideration.  
2 Petitioners alleged that the County is permitting a second single-family residence on lots in rural and  
3 resource lands that contain a single family dwelling unit of 1000 square feet or less. Therefore,  
4 Petitioners asked the Board to:

5 (1) direct the County immediately to discontinue its policy of permitting a second single-family  
6 dwelling unit on all lands with existing dwelling units smaller than 1000 square feet, and

7 (2) direct the County to amend its ordinance within a specific time period to bring its  
8 ordinances and policies into compliance with the GMA.  
9

10 On December 3, 2004, the Board found that Ordinance 21-2002 had not been amended and that the  
11 Board could no longer accept, pending resolution of the County's appeal to the courts, the County's  
12 "practice" of not issuing building permits that did not conform to the Board's order as interim  
13 compliance in lieu of amending its ordinance because now Petitioners dispute whether the County in  
14 fact is complying with this order when issuing building permits for ADUs. Order on Issues for  
15 Reconsideration (December 3, 2004). Therefore, the Board found Ordinance 21-2002 in continuing  
16 noncompliance and invalidity and ordered the County to bring that ordinance into compliance within  
17 120 days. *Ibid.*  
18

19 The County adopted Ordinance 3 – 2005 on April 14, 2005. After a compliance hearing , the Board  
20 issued an order that found because Ordinance 3-2005 was an interim ordinance, it could not find  
21 compliance. Further, the Board found that this ordinance did not cure invalidity of the County's  
22 regulations for detached ADUs because the regulations adopted by this ordinance did not restrict  
23 ADUs in resource lands to the underlying density. Compliance Order (2005) (July 21, 2005).  
24

25 On September 15, 2005, the Board received the County's motion to amend the compliance schedule  
26 followed by a response from the Petitioners in support of amending the schedule. The parties had  
27 jointly filed a motion with the Court of Appeals to stay the issuance of a decision of the County's  
28 appeal of the Thurston County Superior Court's decision in this case in order to craft regulations for  
29 detached ADUs acceptable to both parties. On September 29, 2005, the Board issued an order  
30 amending the compliance schedule. Order Granting Extension (September 2005).  
31  
32

1 On March 3, 2005 the County requested another extension, supported by the Petitioners to  
2 complete the public participation process. The Board granted this extension on March 23, 2006.  
3 Order Granting Extension (March 2006). The County asked for a 60 day extension of the  
4 compliance deadline on May 10, 2006 in order to have a second public hearing on changes the  
5 county council has made to the planning commission draft. Petitioners objected to a 60 day  
6 extension. Later, in a conference with Petitioners, the County, and the Presiding Officer, the  
7 Petitioners and the County agreed to an expedited compliance schedule. On May 25, 2006, the  
8 Board issued an order that extended the compliance period to June 14, 2006 and scheduled a  
9 compliance hearing for June 30, 2006. Order Extending the Compliance Period (May 2006).

10  
11 On June 8, 2006 the San Juan County adopted Ordinance 7-2006.

12  
13 In response to Stephen Ludwig's May 24, 2006 request to intervene, the Board issued an order on  
14 June 13, 2006 adding Mr. Ludwig as a participant.

15  
16 After the May 25, 2006, Order Extending the Compliance Period, the Board received numerous  
17 letters objecting to the expedited compliance schedule and requests to become participants in the  
18 compliance proceedings. In response the Board held a compliance prehearing conference on June  
19 13, 2006 with the County, original petitioners, and parties requesting to be added as participants.

20 On June 21, 2006, the Board issued an order rescheduling the compliance hearing to July 21, 2006  
21 and issued a new briefing schedule. The order also added the following people to the case as  
22 participants: Dorothy Austin, Thomas Baldwin, Miriam M. Ziegler, Howard Tollefson, John B. Evans,  
23 Wanda Evans, Ri Warren, James E. Nelson, Timothy P. Blanchard, Margaret Manning, Donna  
24 Gavora, Jay Kimball, Brian Wiese, Margot Shaw and Doug Marshall. Order Rescheduling the  
25 Compliance Hearing and Adding Parties. Later, on June 30, 2006, the Board added Ralph  
26 Gutschmidt as a participant, and on July 12, 2006, Fred Munder.

27  
28 Also, on June 21, 2006, San Juan County filed its compliance report and a motion to rescind  
29 invalidity. Compliance Report and Motion to Rescind Invalidity.

30  
31 On July 28, 2006, the Board received Request for Reconsideration and Motion to Reschedule  
32 Deadline for Parties to Submit Objections to a Finding of Compliance and Motions to Supplement



1 the Record from James Nelson, and a motion making the same requests from Margaret Manning  
2 and Timothy Blanchard on June 30, 2006. Douglas Marshall filed Motion for Reconsideration of  
3 Scope, and Motion for Extension of Deadlines on June 29, 2006. On July 3, 2006, the Board issued  
4 Order Denying Motions and Requests to Reschedule the Compliance Hearing, Readjust the  
5 Compliance Schedule, and Broaden the Compliance Hearing.

6  
7 Stephen Ludwig filed objections to a finding of compliance on June 27, 2006. The following  
8 participants filed written objections to a finding of compliance and motions to supplement the record  
9 on July 6, 2006: Margaret Manning, Douglas Marshall, James Nelson, John Evans, and Wanda  
10 Evans. Dorothy Austin also filed objections to a finding of compliance on that date. Thomas  
11 Baldwin and Miriam Ziegler filed objections and a motion to supplement the record on July 10, 2006.

12  
13 On July 17, 2006, the County filed San Juan County's Response to Objections to Compliance  
14 Finding and Friends filed Petitioners' Response to Objections and Brief in Support of Lifting Invalidity  
15 and Opposition to Motions to Supplement the Record.

16  
17 The Board held a compliance hearing in Anacortes on July 21, 2006. Deputy Prosecutor Cameron  
18 Carter represented San Juan County; Lynn Bahrych and David Mann represented Petitioners.  
19 James Nelson, Douglas Marshall, John Evans, Timothy Baldwin, Fred Munder, Stephen Ludwig, Ri  
20 Warren, and Ralph Gutschmidt spoke in opposition to a finding of compliance and lifting invalidity.  
21 Board members Gayle Rothrock, Margery Hite, and Holly Gadbow attended.

22  
23 On August 8, 2006, the Board received Motion to Clarify and /or Modify Previous Orders of Invalidity  
24 and for Other Relief along with Memorandum in Support of Motions Regarding Ordinance 11-2006 .

25 On August 29, 2006 the Board issued Order on County's Motion Regarding Ordinance 11-2006.

26 On August 18, 2006, the Board issued Order Lifting Invalidity.

27  
28 On August 22, 2006 Order on Supplementing the Record was issued on the motions to supplement  
29 the record in response to motions to supplement the record filed by Douglas Marshall, James  
30 Nelson, Ri Warren, John Evans, Wanda Evans, Thomas Baldwin, Miriam Ziegler, and Ralph  
31 Gutschmidt.

32 **Case No. 6-2-0024c**

1 Between July 17, 2006 and August 14, 2007, the Board received petitions for review from the  
2 following people: Margaret Manning and Timothy Blanchard, Donna Gavora, Thomas Baldwin,  
3 Douglas Marshall, and Miriam Ziegler, Wanda Evans, John Evans, Brian and Orgelina Wiese, Ralph  
4 Gutschmidt, James Nelson, and Stephen Ludwig. Donna Gavora's case was consolidated with  
5 Margaret Manning and Timothy Blanchard's case.

6  
7 A telephonic prehearing conference was held on August 23, 2006 with all petitioners attending as  
8 well as San Juan County Deputy Prosecuting Attorney Cameron Carter, and Presiding Officer Holly  
9 Gadshaw. The Prehearing Order was issued on August 31, 2006. Several petitioners objected to  
10 the issues statements as presented. On September 18, 2006, the Presiding Officer issued an  
11 Amended Prehearing Order.

12  
13 On August 31, 2006, an order consolidated these cases, which captioned it as *James Nelson et al v.*  
14 *San Juan County*, Case No. 06-2-0024c.

15  
16 Friends of San Juans filed a motion to intervene on September 8, 2006. An order granting Friends  
17 of San Juans intervention was issued on September 20, 2006.

18  
19 Petitioners Stephen Ludwig, Ralph Gutschmidt, John Evans, Wanda Evans, and Thomas Baldwin,  
20 Douglas Marshall, and Miriam Ziegler filed Prehearing Briefs. The Baldwin, Marshall, and Ziegler  
21 brief was not served on Intervenor Friends until December 11, 2006. Intervenor Friends filed its  
22 brief on December 7, 2006.

23  
24 In response to motions for from the County, the Board extended the County's briefing schedule  
25 deadline until December 11, 2006. The Presiding Officer also adjusted the time for Intervenor  
26 Friends to respond to the Baldwin Marshall, and Ziegler Prehearing Brief, for Petitioners to respond  
27 to the County's Brief, and for Baldwin, Marshall, and Ziegler to respond to Friends' Response Brief in  
28 an order issued on December 13, 2006.

29  
30 A Hearing on the Merits was held at the Eastsound Fire Station on January 4, 2006. The County  
31 was represented by Special Deputy Prosecutor Craig Magnusson. David Mann and Lynn Bahrych  
32 represented Friends. John Evans, Wanda Evans, Ralph Gutschmidt, and Stephen Ludwig

1 represented themselves. Douglas Marshall represented himself, Thomas Baldwin and Miriam  
2 Ziegler. Board Members James McNamara, Margery Hite, and Holly Gadbow attended.

3  
4 At the hearing after receiving no objection from the County or Friends, the Board granted the  
5 Baldwin, Marshall, and Ziegler motion to supplement the record with the following items with the  
6 following index numbers, with the stipulation that the Board will give these items the appropriate  
7 weight:

- 8 • 1501 – August 30, 2005 e-mail from Commissioner Lichter to Commissioner Richter
- 9 • 1502 – August 20, 2005 e-mail from Prosecuting Attorney Randall Gaylord to County  
10 Commissioners
- 11 • 1503 – August 31, 2005 e-mail from Stephanie Buffum Filed to Commissioner Lichter that  
12 forwarded an earlier e-mail from Lynn Bahrych
- 13 • 1504 – 1507 – Cover memo from Friends to the San Juan Board of Commissioners,  
14 including a three page 3-page document executed by Lynn Bahrych and Stephanie Buffum  
15  
16  
17  
18  
19  
20  
21  
22  
23  
24  
25  
26  
27  
28  
29  
30  
31  
32



# THANK YOU

We have received your amendment submission. Please allow 1-3 business days for review. Please keep the Submittal ID as your receipt and for any future questions. We will also send an email receipt to all contacts listed in the submittal.

## Submittal ID: 2020-S-2032

### Submittal Date Time: 11/18/2020

#### Submittal Information

**Jurisdiction** Snohomish County  
**Submittal Type** Request for Expedited Review / Notice of Intent to Adopt  
**Amendment Type** Amendment  
 Development Regulation Amendment

#### Amendment Information

##### Brief Description

Proposed amendments updating requirements in Snohomish County Code regarding accessory apartments (accessory dwelling units).

Yes, this is a part of the 8-year periodic update schedule, required under RCW 36.70A.130.

Anticipated/Proposed Date of Adoption

#### Attachments

Attachment Type	File Name	Upload Date
Development Regulation Amendment - Draft	Accessory Apartment Code Update_DRAFT Ordinance_8.24.20 (1).pdf	11/18/2020 09:59 AM

#### Contact Information

**Prefix** Mr.  
**First Name** Mitchell  
**Last Name** Brouse  
**Title** Senior Planner  
**Work** (425) 388-5127  
**Cell**  
**Email** mitchell.brouse@gmail.com

Accessory Dwelling Units

Index # - File Name: 1\_0027 - Submittal-Receipt-Email-2020-S-2032.pdf  
 Yes, I would like to be contacted for Technical Assistance.

**Certification**

---

I certify that I am authorized to submit this Amendment for the Jurisdiction identified in this Submittal and all information provided is true and accurate to the best of my knowledge.

**Full Name** Mitchell Brouse  
**Email** mitchell.brouse@snoco.org



**Snohomish County**

**Planning and Development Services**

3000 Rockefeller Ave., M/S 604

Everett, WA 98201-4046

(425) 388-3311

[www.snoco.org](http://www.snoco.org)

**Dave Somers**

*County Executive*

## **SNOHOMISH COUNTY ENVIRONMENTAL CHECKLIST**

### **Purpose of Checklist**

The State Environmental Policy Act (SEPA), chapter 43.21C RCW, requires all governmental agencies to consider the environmental impacts of a proposal before making decisions. An environmental impact statement (EIS) must be prepared for all proposals with probable significant adverse impacts on the quality of the environment. The purpose of this checklist is to provide information on the impacts from this proposal (and to reduce or avoid impacts if possible) to help the agency decide whether an EIS is required.

### **A. Background**

#### **1. Name of proposed project:**

Proposed non-project proposal to amend Snohomish County Code (SCC) Title 30 to update regulations related to accessory dwelling units (ADUs).

#### **2. Name of applicant:**

Snohomish County, Department of Planning and Development Services.

#### **3. Address and phone number of applicant and contact person:**

Mitchell Brouse, Project Manager  
3000 Rockefeller, M/S 604  
Everett, WA 98201  
Phone: 425-388-5127  
Email: [mitchell.brouse@snoco.org](mailto:mitchell.brouse@snoco.org)

#### **4. Date checklist prepared:**

March 19, 2021

**5. Agency requesting checklist:**

Snohomish County, Department of Planning and Development Services

**6. Proposed timing or schedule (including phasing, if applicable):**

Planning Commission briefing: June 23, 2020

Planning Commission public hearing: July 28, 2020

County Council public hearing: Tentatively, April, 2021

**7. Do you have any plans for future additions, expansion, or further activity related to or connected with this proposal? If yes, explain.**

This proposal is for a non-project action to amend the regulations regarding the development of accessory dwelling units (ADUs), also referred to as accessory apartments. Site-specific actions may be proposed by private or public entities in the future, which will be reviewed for compliance with the regulations in effect at the time of application.

**8. List any environmental information you know about what has been prepared, or will be prepared, directly related to this proposal.**

This non-project proposal is consistent with the policies and goals of the adopted GMA Comprehensive Plan, which included an EIS, that was adopted on June 3, 2015. No additional environmental information or studies have been prepared for the proposed development regulations.

**9. Do you know whether applications are pending for governmental approvals of other proposals directly affecting the property covered by your proposal? If yes, explain.**

This is a non-project proposal, which affects the regulation accessory apartments within unincorporated Snohomish County. Project-specific proposals affecting unincorporated Snohomish County are under consideration at any given time.

**10. List any government approvals or permits that will be needed for your proposal, if known.**

Adoption by the Snohomish County Council is required for this non-project proposal.

**11. Give brief, complete description of your proposal, including the proposed uses and the size of the project and site. There are several questions later in this checklist that ask you to describe certain aspects of your proposal. You do not need to repeat those answers on this page.**

1. This non-project proposal will amend SCC 30.22.100, SCC 30.22.110, and SCC 30.22.120 to change accessory dwelling units from an administrative conditional use to a permitted use in all districts that also allow a single-family dwelling.
2. This non-project proposal will amend SCC 30.23.235 to eliminate the prohibition on accessory dwelling units on substandard lots and replace it with a prohibition on detached ADUs on rural lots that do not meet the minimum required lot area for the zone in which they are located.
3. This non-project proposal will amend SCC 30.25.020 and SCC 30.25.028 to eliminate perimeter landscaping requirements and buffer requirements for accessory dwelling units located in zones categorized as residential, multi-family, or commercial.
4. This non-project proposal will amend SCC 30.26.030 to update the number of parking spaces required for accessory dwelling units located in the urban zones.
5. This non-project proposal will amend SCC 30.28.010 to update the development standards for accessory dwelling units including adding standards for ADUs in the rural areas to protect rural character and limit sprawl.
6. This non-project proposal will amend chapter 30.91A SCC to add a definition for the term “accessory dwelling unit” and update the definitions of “accessory apartment, attached” and “accessory apartment, detached.”
7. This non-project proposal will amend chapters 30.22, 30.24, 30.31A, 30.35A, 30.41G, 30.66C, and 30.91D SCC to replace the term “accessory apartments” with the term “accessory dwelling units.”

**12. Location of the proposal. Give sufficient information for a person to understand the precise location of your proposed project, including a street address, if any, and section, township, and range, if known. If a proposal would occur over a range of area, provide the range or boundaries of the site(s). Provide a legal description, site plan, vicinity map, and topographic map, if reasonably available. While you should submit any plans required by the agency, you are not required to duplicate maps or detailed plans submitted with any permit applications related to this checklist. \_**

This non-project proposal affects all zones in the unincorporated portions of Snohomish County where single-family dwellings are a permitted use.

## **B. Environmental Elements**

### **1. Earth**

#### **a. General description of the site:**

(Circle one): **Flat, rolling, hilly, steep slopes, mountainous, other** all  
of the above \_\_\_\_\_

Lands within the jurisdiction of Snohomish County include a variety of terrain such as flat, rolling, hilly, and steep slopes. The lands that are proposed to be effected by this non-project proposal are that are located in the R-9600, R-8,400,



R-7,200, T, LDMR, MR, RD, RRT-10, R-5, CRC, F, F&R, A-10, MC, SA-1, RC, R-20,000, R-12,500, and WFB zones.

**b. What is the steepest slope on the site (approximate percentslope)?**

Slopes in excess of 100% can be found within the jurisdiction of Snohomish County.

**c. What general types of soils are found on the site (for example, clay, sand, gravel, peat, muck)? If you know the classification of agricultural soils, specify them and note any agricultural land of long-term commercial significance and whether the proposal results in removing any of these soils.**

A range of soil types are found within the jurisdiction of Snohomish County. This non-project proposal will not remove soils in agricultural lands designated as of long-term commercial significance.

**d. Are there surface indications or history of unstable soils in the immediate vicinity? If so, describe.**

Certain areas within Snohomish County have a history of surface instability associated with periods of heavy rainfall. Other areas have a history of more deep-seated instability associated with landslide activity. In particular, flooding includes mudslides which are caused by overflow of waters of rapid runoff of surface waters.

**e. Describe the purpose, type, total area, and approximate quantities and total affected area of any filling, excavation, and grading proposed. Indicate source of fill.**

As a non-project proposal, no filling or grading is proposed. Any future site-specific development or land use proposal not exempted by WAC 197-11-800 or SCC 30.61.035 would be subject to a separate SEPA review, which would include review of any proposed grading or filling activity.

**f. Could erosion occur as a result of clearing, construction, or use? If so, generally describe.**

As a non-project action, no erosion will occur as a direct result of this proposal. Any future site-specific development or land use proposal not exempted by WAC 197-11-800 or SCC 30.61.035 would be subject to a separate SEPA review, which would include review of any proposed clearing and construction that might result in erosion.

**g. About what percent of the site will be covered with impervious surfaces after project construction (for example, asphalt or buildings)?**

As a non-project action, no impervious surface coverage will occur as a result of this proposal. Any future site-specific development or land use proposal not exempted by WAC 197-11-800 or SCC 30.61.035 would be subject to a separate SEPA review, which would include review of any proposed impervious surface area.

**h. Proposed measures to reduce or control erosion, or other impacts to the earth, if any:**

As a non-project proposal, no erosion reduction or control measures are proposed or required. Future site-specific development or land use action not exempted by WAC 197-11-800 or SCC 30.61.035 would be subject to project level SEPA and regulatory review and would require the implementation of applicable County regulations to reduce or control erosion or other impacts to the earth.

**2. Air**

**a. What types of emissions to the air would result from the proposal during construction, operation, and maintenance when the project is completed? If any, generally describe and give approximate quantities if known.**

As a non-project action, no emissions to air will occur as a result of this proposal.

**b. Are there any off-site sources of emissions or odor that may affect your proposal? If so, generally describe.**

Not applicable.

**c. Proposed measures to reduce or control emissions or other impacts to air, if any:**

As a non-project proposal, no measures to reduce or control emissions are required or proposed. Future site-specific development or land use action not exempted by WAC 197-11-800 or SCC 30.61.035 would be subject to project level SEPA and regulatory review and would require the implementation of applicable County regulations to reduce or control emissions or other impacts to air, if any.

**3. Water**

**a. Surface Water:**

**1) Is there any surface water body on or in the immediate vicinity of the site (including year-round and seasonal streams, saltwater, lakes, ponds, wetlands)? If yes, describe type and provide names. If appropriate, state what stream or river it flows into.**

There are several streams, seasonal streams, and bodies of water located within Snohomish County.

- 2) Will the project require any work over, in, or adjacent to (within 200 feet) the described waters? If yes, please describe and attach available plans.**

As a non-project action, this proposal will not require any work in, or adjacent to, the described waters. Future site-specific development or land use actions not exempted by WAC 197-11-800 or SCC 30.61.035 would be subject to project level SEPA and regulatory review and would require the implementation of applicable County regulations to reduce or control activities near surface water bodies, if any.

- 3) Estimate the amount of fill and dredge material that would be placed in or removed from surface water or wetlands and indicate the area of the site that would be affected. Indicate the source of fill material.**

As a non-project proposal, no fill or dredge material will be placed or removed from surface water or wetlands.

- 4) Will the proposal require surface water withdrawals or diversions? Give general description, purpose, and approximate quantities if known.**

As a non-project proposal, no surface water withdrawals or diversion will be required.

- 5) Does the proposal lie within a 100-year floodplain? If so, note location on the site plan.**

Not applicable because this is a non-project action.

- 6) Does the proposal involve any discharges of waste materials to surface waters? If so, describe the type of waste and anticipated volume of discharge.**

As a non-project action, no discharges of waste materials to surface waters will occur as a result of this proposal.

**b. Ground Water:**

- 1) Will groundwater be withdrawn from a well for drinking water or other purposes? If so, give a general description of the well, proposed uses and approximate quantities withdrawn from the well. Will water be discharged to groundwater? Give general description, purpose, and approximate quantities if known.**

As a non-project proposal, no groundwater will be withdrawn or discharged. However, future site-specific projects may propose ADUs that are connected to a well, resulting in groundwater withdrawal. The amendments to Snohomish County Code that are proposed by this not-project proposal require that all ADUs have both physical and legal access to water. Requiring legal availability will prohibit permit issuance unless the proposed ADU has legal access to a water right. This provision will protect groundwater resources from being overdrawn as a result of this proposal.

- 2) Describe waste material that will be discharged into the ground from septic tanks or other sources, if any (for example: Domestic sewage; industrial, containing the following chemicals; agricultural; etc.). Describe the general size of the system, the number of such systems, the number of houses to be served (if applicable), or the number of animals or humans the system(s) are expected to serve.**

As a non-project action, no waste material will be discharged from septic tanks or other sources as a result of this proposal. Future development or land use actions not exempted by WAC 197-11-800 or SCC 30.61.035 that would likely result in discharges from stormwater runoff would be subject to project-level SEPA and regulatory review.

Further, the amendments proposed by this non-project proposal require that applicants looking to construct an ADU provide documentation that the proposed sewage system is capable of handling the additional demand placed on the system by the proposed ADU.

**c. Water runoff (including stormwater):**

- 1) Describe the source of runoff (including storm water) and method of collection and disposal, if any (include quantities, if known). Where will this water flow? Will this water flow into other waters? If so, describe.**

As a non-project action, no runoff will occur as a result of this proposal. Any future site-specific development or land use action proposal would be subject to a separate SEPA and development permit review, which would address runoff management.

- 2) Could waste materials enter ground or surface waters? If so, generally describe.**

As a non-project action no runoff will occur as a result of this proposal. Any future site-specific development or land use action proposal not exempted by WAC 197-11-800 or SCC 30.61.035 would be subject to a separate SEPA and development permit review, which would address runoff management.

**d. Does the proposal alter or otherwise affect drainage patterns in the vicinity of the site? If so, describe.**

As a non-project action, no drainage patterns will be affected as a result of this proposal. Any future site-specific development or land use proposal not exempted by WAC 197-11-800 or SCC 30.61.035 would be subject to a separate SEPA and permit review, which would address drainage.

**e. Proposed measures to reduce or control surface, ground, and runoff water, and drainage pattern impacts, if any:**

As a non-project proposal, no measures are proposed or required to reduce impacts to surface or groundwater. Any future site-specific development or land use proposal not exempted by WAC 197-11-800 or SCC 30.61.035 would be subject to a separate SEPA and permit review.

**4. Plants**

**a. Check the types of vegetation found on the site:**

deciduous tree: alder, maple, aspen, other

evergreen tree: fir, cedar, pine, other

shrubs

grass

pasture

crop or grain

Orchards, vineyards or other permanent crops.

wet soil plants: cattail, buttercup, bullrush, skunk cabbage, other

water plants: water lily, eelgrass, milfoil, other

other types of vegetation

All types of the above vegetation occur in various locations throughout the county.

**b. What kind and amount of vegetation will be removed or altered?**

As a non-project action, no vegetation will be removed as a direct result of this proposal. Any future site-specific development project not exempted by WAC 197-11-800 or SCC 30.61.035 would be subject to a separate SEPA evaluation of any proposed vegetation removal or alteration.

**c. List threatened and endangered species known to be on or near the site.**

Threatened and endangered vegetation species can be found in various locations throughout Snohomish County.

**d. Proposed landscaping, use of native plants, or other measures to preserve or enhance vegetation on the site, if any:**

As a non-project action, no measures to preserve or enhance vegetation are required for this proposal. Any future site-specific development or land use action not exempted by WAC 197-11-800 or SCC 30.61.035 would be subject to a separate SEPA and permit review, which would include review of any proposed landscaping or measures to preserve or enhance vegetation on the site. The U.S Fish and Wildlife Services provides listing for ESA species under its jurisdiction; and the Washington State Department of Fish and Wildlife provides listing for priority habitat species under its jurisdiction. These resources are consulted for mitigation of impacts from site-specific proposals under consideration.

**e. List all noxious weeds and invasive species known to be on or near the site.**

All types of noxious weeds and invasive species occur throughout the county.

**5. Animals**

**a. List any birds and other animals which have been observed on or near the site or are known to be on or near the site.**

Birds: **hawk, heron, eagle, songbirds, other:** \_\_\_\_\_  
Mammals: **deer, bear, elk, beaver, other:** \_\_\_\_\_  
Fish: **bass, salmon, trout, herring, shellfish, other:** \_\_\_\_\_

All of the above animal species may be found in various locations throughout the county including those areas affected by this non-project proposal.

**b. List any threatened and endangered species known to be on or near the site.**

Threatened and endangered bird, animal and fish species can be found in various locations throughout Snohomish County.

**c. Is the site part of a migration route? If so, explain.**

Yes. Wildlife species do migrate through the county, but as a non-project action, this proposal will not impact migratory species.

**d. Proposed measures to preserve or enhance wildlife, if any:**

As a non-project proposal, no measures to preserve or enhance wildlife are required or proposed. Any future site-specific development project not exempted by WAC 197-11-800 or SCC 30.61.035 would be subject to a separate SEPA review, which would include review and implementation of measures to preserve or enhance wildlife, if any. The

U.S Fish and Wildlife and National Marine Fisheries Services provide listing for ESA species under their jurisdiction; and the Washington State Department of Fish and Wildlife provides listing for sensitive species under its jurisdiction. These resources are consulted for mitigation of impacts from site-specific proposals under consideration.

- e. **List any invasive animal species known to be on or near the site.**

All types of invasive animal species exist throughout the county.

## 6. Energy and Natural Resources

- a. **What kinds of energy (electric, natural gas, oil, wood stove, solar) will be used to meet the completed project's energy needs? Describe whether it will be used for heating, manufacturing, etc.**

As a non-project proposal, energy will not be consumed.

- b. **Would your project affect the potential use of solar energy by adjacent properties? If so, generally describe.**

As a non-project action, there will be no impact on solar energy as a result of this proposal.

- c. **What kinds of energy conservation features are included in the plans of this proposal? List other proposed measures to reduce or control energy impacts, if any:**

As a non-project action, energy conservation features are not applicable to this proposal. Any future site-specific development project not exempted by WAC 197-11-800 or SCC 30.61.035 would be subject to a separate SEPA review, which would include review and implementation of measures to reduce or control energy impacts, if any.

## 7. Environmental Health

- a. **Are there any environmental health hazards, including exposure to toxic chemicals, risk of fire and explosion, spill, or hazardous waste, that could occur as a result of this proposal? If so, describe.**

As a non-project action, no environmental health hazards will result as a consequence of this proposal.

- 1) **Describe any known or possible contamination at the site from present or past uses.**

As a non-project proposal, this is not applicable. Any future site-specific development project not exempted by WAC 197-11-800 or SCC 30.61.035

would be subject to a separate SEPA review, which would include identification of known or possible contamination, if any.

- 2) **Describe existing hazardous chemicals/conditions that might affect project development and design. This includes underground hazardous liquid and gas transmission pipelines located within the project area and in the vicinity.**

As a non-project proposal, this is not applicable. Any future site-specific development project not exempted by WAC 197-11-800 or SCC 30.61.035 would be subject to a separate SEPA review, which would include identification existing hazardous chemicals/conditions, if any.

- 3) **Describe any toxic or hazardous chemicals that might be stored, used, or produced during the project's development or construction, or at any time during the operating life of the project.**

As a non-project proposal, this is not applicable. Any future site-specific development project not exempted by WAC 197-11-800 or SCC 30.61.035 would be subject to a separate SEPA review, which would include a review of toxic or hazardous chemicals stored, used, or produced during the project's development or construction, or at any time during the operating life of the project, if any.

- 4) **Describe special emergency services that might be required.**

As a non-project action, no special emergency services are required by this proposal.

- 5) **Proposed measures to reduce or control environmental health hazards, if any:**

As a non-project action, no measures to reduce or control environmental health hazards are required for this proposal. Any future site-specific development project not exempted by WAC 197-11-800 or SCC 30.61.035 would be subject to a separate SEPA review, which would include review and implementation of measures to reduce or control environmental health hazards, if any.

**b. Noise**

- 1) **What types of noise exist in the area which may affect your project (for example: traffic, equipment, operation, other)?**

This non-project proposal will not be affected by noise.



- 2) What types and levels of noise would be created by or associated with the project on a short-term or a long-term basis (for example: traffic, construction, operation, other)? Indicate what hours noise would come from the site.**

This non-project proposal will not generate noise.

- 3) Proposed measures to reduce or control noise impacts, if any:**

As a non-project proposal, no measures to reduce or control noise impacts are required or proposed. Any future site-specific development project not exempted by WAC 197-11-800 or SCC 30.61.035 would be subject to a separate SEPA review, which would include review and implementation of measures to reduce or control noise impacts, if any.

## **8. Land and Shoreline Use**

- a. What is the current use of the site and adjacent properties? Will the proposal affect current land uses on nearby or adjacent properties? If so, describe.**

This non-project proposal includes amendments to Snohomish County Code that affect all areas located in the R-9600, R-8,400, R-7,200, T, LDMR, MR, RD, RRT-10, R-5, CRC, F, F&R, A-10, MC, SA-1, RC, R-20,000, R-12,500, and WFB zones. Any future site-specific development project not exempted by WAC 197-11-800 or SCC 30.61.035 would be subject to a separate SEPA review, which would include review and implementation of measures to reduce or control impacts to adjacent properties, if any.

- b. Has the project site been used as working farmlands or working forest lands? If so, describe. How much agricultural or forest land of long-term commercial significance will be converted to other uses as a result of the proposal, if any? If resource lands have not been designated, how many acres in farmland or forest land tax status will be converted to nonfarm or nonforest use?**

This non-project proposal pertains to all areas of unincorporated Snohomish County that are located in the R-9600, R-8,400, R-7,200, T, LDMR, MR, RD, RRT-10, R-5, CRC, F, F&R, A-10, MC, SA-1, RC, R-20,000, R-12,500, and WFB zones. These areas include property that may have been, may be, or is currently being used as working farmlands or working forestlands.

- 1) Will the proposal affect or be affected by surrounding working farm or forest land normal business operations, such as oversize equipment access, the application of pesticides, tilling, and harvesting? If so, how:**

As a non-project action, this proposal will not affect or be affected by surrounding working farm or forest land operations.

**c. Describe any structures on the site.**

Not applicable to this non-project proposal.

**d. Will any structures be demolished? If so, what?**

As a non-project action, no structures will be demolished as a result of this proposal.

**e. What is the current zoning classification of the site?**

This non-project proposal pertains to the R-9600, R-8,400, R-7,200, T, LDMR, MR, RD, RRT-10, R-5, CRC, F, F&R, A-10, MC, SA-1, RC, R-20,000, R-12,500, and WFB zoning classifications found in Snohomish County Code title 30.

**f. What is the current comprehensive plan designation of the site?**

This non-project proposal pertains to the Urban Low Density Residential (ULDR), Urban Medium Density Residential (UMDR), Urban High Density Residential (UHDR), Urban Horticulture (UH), Local Forest (LF), Low Density Rural Residential (LDRR), Rural Residential-10 (RR-10), Rural Residential-5 (RR-5), Rural Residential (RR), Rural Residential RD (RR-RD), Clearview Rural Commercial (CRC), Upland Commercial Farmland (UCF), Riverway Commercial Farmland (RCF), Recreational Land (RL), and Commercial Forest (CF) land use designations.

**g. If applicable, what is the current shoreline master program designation of the site?**

Not applicable to this non-project action.

**h. Has any part of the site been classified as a critical area by the city or county? If so, specify.**

Not applicable to this non-project action.

**i. Approximately how many people would reside or work in the completed project?**

As a non-project proposal, this is not applicable.

**j. Approximately how many people would the completed project displace?**

As a non-project proposal, this is not applicable.

**k. Proposed measures to avoid or reduce displacement impacts, if any:**

As a non-project action, no measures to avoid or reduce displacement impacts are required by this proposal.

**l. Proposed measures to ensure the proposal is compatible with existing and projected land uses and plans, if any:**

As a non-project proposal, the proposed code amendments are compatible with the land uses and plans.

**m. Proposed measures to reduce or control impacts to agricultural and forest lands of long-term commercial significance, if any:**

As a non-project action, no impacts to agricultural and forest lands of long-term commercial significance would occur as a result of this proposal. This proposed non-project action does not change existing regulations or protections relating to agricultural and forest lands of long-term commercial significance, however, it does alter standards for the development of ADUs on some such properties.

**9. Housing**

**a. Approximately how many units would be provided, if any? Indicate whether high, middle, or low-income housing.**

As a non-project action, no housing units would be provided directly by this proposal. However, because the amendments reduce the barriers to construction of ADUs and allow two ADUs per urban lot, this proposal could result in additional housing units being constructed in lower density urban areas.

**b. Approximately how many units, if any, would be eliminated? Indicate whether high, middle, or low-income housing.**

As a non-project action, no housing units would be eliminated by this proposal.

**c. Proposed measures to reduce or control housing impacts, if any:**

As a non-project action, no measures to reduce or control impacts to housing are required or proposed. However, the proposed amendments include standards intended to minimize the impacts from the construction of new ADUs.

**10. Aesthetics**

**a. What is the tallest height of any proposed structure(s), not including antennas; what is the principal exterior building material(s) proposed?**

As a non-project proposal this is not applicable.

**b. What views in the immediate vicinity would be altered or obstructed?**

As a non-project proposal this is not applicable.

**c. Proposed measures to reduce or control aesthetic impacts, if any:**

As a non-project action, no measures to reduce or control aesthetic impacts are required or proposed. However, the proposed non-project action would adopt architectural and design standards to ensure that all ADUs developed are compatible with the development on the property.

**11. Light and Glare**

**a. What type of light or glare will the proposal produce? What time of day would it mainly occur?**

As a non-project action, no light or glare will occur as a result of this proposal.

**b. Could light or glare from the finished project be a safety hazard or interfere with views?**

As a non-project proposal this is not applicable.

**c. What existing off-site sources of light or glare may affect your proposal?**

Not applicable to this non-project proposal.

**d. Proposed measures to reduce or control light and glare impacts, if any:**

As a non-project action, no measures to reduce or control light and glare impacts are required or proposed.

**12. Recreation**

**a. What designated and informal recreational opportunities are in the immediate vicinity?**

The non-project action affects land in unincorporated Snohomish County, some of which may have opportunities for hunting, fishing, bird watching and other recreational activities.

**b. Would the proposed project displace any existing recreational uses? If so, describe.**

This non-project proposal will not displace any existing recreational uses.

- c. Proposed measures to reduce or control impacts on recreation, including recreation opportunities to be provided by the project or applicant, if any:**

As a non-project action, no measures to reduce or control impacts on recreation are proposed or required. Any future site-specific development proposal not exempted by WAC 197-11-800 or SCC 30.61.035 would be subject to a separate SEPA review, which would include review and implementation of measures to reduce or control impacts on recreation, including recreation opportunities to be provide by the project or applicant, if any

### **13. Historic and cultural preservation**

- a. Are there any buildings, structures, or sites, located on or near the site that are over 45 years old listed in or eligible for listing in national, state, or local preservation registers ? If so, specifically describe.**

Not applicable to this non-project proposal.

- b. Are there any landmarks, features, or other evidence of Indian or historic use or occupation? This may include human burials or old cemeteries. Are there any material evidence, artifacts, or areas of cultural importance on or near the site? Please list any professional studies conducted at the site to identify such resources.**

Not applicable to this non-project action. Future development proposals may be conditioned or subject to further review on a site-specific basis under Chapter 30.32D SCC – Historic and Archaeological Resources.

- c. Describe the methods used to assess the potential impacts to cultural and historic resources on or near the project site. Examples include consultation with tribes and the department of archeology and historic preservation, archaeological surveys, historic maps, GIS data, etc.**

Not applicable to this non-project action. Future development proposals may be conditioned or subject to further review on a site-specific basis under Chapter 30.32D SCC – Historic and Archaeological Resources.

- d. Proposed measures to avoid, minimize, or compensate for loss, changes to, and disturbance to resources. Please include plans for the above and any permits that may be required.**

As a non-project action, no measures to reduce or control impacts on resources are proposed or required. Any future site-specific development proposal not exempted by WAC 197-11-800 or SCC 30.61.035 would be subject to a separate SEPA review, which would include review and implementation of measures to reduce or control impacts on resources.

### **14. Transportation**

- a. Identify public streets and highways serving the site or affected geographic area and describe proposed access to the existing street system. Show on site plans, if any.**

Various highways and state routes and local streets service Snohomish County.

- b. Is the site or affected geographic area currently served by public transit? If so, generally describe. If not, what is the approximate distance to the nearest transit stop?**

Various transit services exists in Snohomish County.

- c. How many additional parking spaces would the completed project or non-project proposal have? How many would the project or proposal eliminate?**

As a non-project proposal, no parking spaces are proposed or eliminated. Future site-specific development must meet the minimum parking requirements as mandated by Chapter 30.26 of the Snohomish County Code.

- d. Will the proposal require any new or improvements to existing roads, streets, pedestrian, bicycle or state transportation facilities, not including driveways? If so, generally describe (indicate whether public or private).**

Not applicable to this non-project proposal.

- e. Will the project or proposal use (or occur in the immediate vicinity of) water, rail, or air transportation? If so, generally describe.**

Not applicable to this non-project proposal.

- f. How many vehicular trips per day would be generated by the completed project or proposal? If known, indicate when peak volumes would occur and what percentage of the volume would be trucks (such as commercial and nonpassenger vehicles). What data or transportation models were used to make these estimates?**

This non-project action will not directly generate any vehicular trips per day. Any future site specific development or land use proposal not exempted by WAC 197-11-800 or SCC 30.61.035 would be subject to a separate SEPA and permit review, which would include review of traffic issues.

- g. Will the proposal interfere with, affect or be affected by the movement of agricultural and forest products on roads or streets in the area? If so, generally describe.**

As a non-project action, the proposal will not interfere with, affect, or be affected by the movement of agricultural and forest products on roads or streets. Any

future development or land use proposal w not exempted by WAC 197-11-800 or SCC 30.61.035 would be subject to a separate SEPA and permit review, which will include review of impacts interfering, affecting, or resulting from the movement of agricultural and forest products on roads or streets.

**h. Proposed measures to reduce or control transportation impacts, if any:**

As a non-project action, no measures to reduce or control transportation are proposed or required. Any future site-specific development or land use action not exempted by WAC 197-11-800 or SCC 30.61.035 would be subject to a separate SEPA and concurrency review, which would include implementation of measures to reduce or control any transportation impacts.

**15. Public Services**

**a. Would the project result in an increased need for public services (for example: fire protection, police protection, public transit, health care, schools, other)? If so, generally describe.**

As a non-project action, this proposal will not result in an increased need for public services.

**b. Proposed measures to reduce or control direct impacts on public services, if any.**

As a non-project proposal, no measures to reduce or control impacts on public services are proposed or required.

**16. Utilities**

**a. Circle utilities currently available at the site:**

Electricity, natural gas, water, refuse service, telephone, sanitarysewer, septic system, other \_\_\_\_\_

Not applicable to this non-project proposal.

**b. Describe the utilities that are proposed for the project, the utility providing the service, and the general construction activities on the site or in the immediate vicinity which might be needed.**

As a non-project proposal, no utilities are proposed or required.

**C. Signature**

The above answers are true and complete to the best of my knowledge. I understand that the lead agency is relying on them to make its decision.

Signature: *Mitchell Brouse*  
Mitchell Brouse (Mar 24, 2021 11:39 CDT)  
\_\_\_\_\_  
Mitchell Brouse, Project Manager  
Senior Planner, Planning and Development Services

Date Submitted: March 24, 2021



## **D. Supplemental sheet for non-project actions**

### **1. How would the proposal be likely to increase discharge to water; emissions to air; production, storage, or release of toxic or hazardous substances; or production of noise?**

The proposal has the potential to increase stormwater runoff on development sites, however standards are proposed that will limit such increases. The proposed code changes will not likely contribute to the production, storage, or release of toxic or hazardous substances; or the production of noise.

#### **Proposed measures to avoid or reduce such increases are:**

This non-project action does not propose to change any existing regulations for stormwater management, and any development projects will be required to meet all applicable regulations, including implementation of low impact development strategies whenever feasible. Future site-specific land activity not exempted by WAC 197-11-800 or SCC 30.61.035 would be subject to project level environmental analysis and threshold determination.

Beyond that, the proposed standards require that detached ADUs in the rural area be located within 100 feet of the primary dwelling and share a driveway with that dwelling, which limiting the impervious surface associated with detached ADUs in the rural area. Further, the proposed amendments require that applicants looking to construct an ADU provide documentation that the proposed sewage system is capable of handling the additional demand placed on the system by the proposed ADU. Which will protect from an increase in discharges of toxic or hazardous substances.

### **2. How would the proposal be likely to affect plants, animals, fish, or marine life?**

As a non-project action the proposal is not likely to impact animals, fish, or marine life. Future development will be subject to the county's critical area regulations under Title 30, which include provisions to protect streams, wetlands, and wildlife.

#### **Proposed measures to protect or conserve plants, animals, fish, or marine life are:**

The County's critical areas regulations regulate development in environmentally sensitive areas. Future site-specific land activity not exempted by WAC 197-11-800 or SCC 30.61.035 would be subject to project level environmental analysis and threshold determinations.

Future site-specific land activity will be required to meet all relevant development regulations, including open space, landscaping and tree canopy regulations, which help to protect and conserve plants and habitat.

### **3. How would the proposal be likely to deplete energy or natural resources?**

The proposal would not likely deplete energy or natural resources. The proposed amendments do not alter the underlying standards that restrict development in natural resource areas. The prescriptive minimum lot size is 20 acres in the F-Forestry zone, 10 acres in the A-10-Agricultural and MC-Mineral Conservation zones, and 200,000 square feet in the F&R-Forestry and Recreation zone. Under the proposed amendments, detached ADUs would only be allowed on lots that exceed the minimum lot size.

**Proposed measures to protect or conserve energy and natural resources are:**

As a non-project action, no measures to conserve energy or natural resources are necessary for this proposal. Future site-specific land activity not exempted by WAC 197-11-800 or SCC 30.61.035 would be subject to project-level environmental analysis and threshold determinations.

- 4. How would the proposal be likely to use or affect environmentally sensitive areas or areas designated (or eligible or under study) for governmental protection; such as parks, wilderness, wild and scenic rivers, threatened or endangered species habitat, historic or cultural sites, wetlands, floodplains, or prime farmlands?**

The proposed code amendments would not likely affect environmentally sensitive areas because vegetation removal is prohibited in critical areas and critical area buffers. As a non-project action, this proposal is unlikely to directly affect environmentally sensitive areas or areas designated (or eligible or under study) for government protection.

**Proposed measures to protect such resources or to avoid or reduce impacts are:**

The County's critical areas regulations regulate development in environmentally sensitive areas. Future site-specific land activity not exempted by WAC 197-11-800 or SCC 30.61.035 would be subject to project level environmental analysis and threshold determinations.

- 5. How would the proposal be likely to affect land and shoreline use, including whether it would allow or encourage land or shoreline uses incompatible with existing plans?**

The proposal is not likely to affect shoreline use. The County's Shoreline Management Plan regulates development in the shoreline designations. This proposal does not encourage incompatible shoreline uses. The proposal is consistent with allowed land uses on lots that allow single-family dwellings and only affects the development of accessory dwellings units, which are allowed only as accessory to a single-family dwelling.

**Proposed measures to avoid or reduce shoreline and land use impacts are:**

The proposed code amendments are consistent with shoreline regulations, so

measures to reduce impacts are not applicable. Future site-specific development proposals in the shoreline environment are subject to County development regulations implementing the Shoreline Management Program, Chapters 30.44 and 30.67 SCC.

Future site-specific development proposals are subject to County development regulations to protect plants, trees, and mitigate stormwater runoff.

**6. How would the proposal be likely to increase demands on transportation or public services and utilities?**

This non-project proposal is unlikely to directly or indirectly increase demands on transportation or public services and utilities. It is unlikely that this proposal will result in a significant amount of additional dwelling units in areas that do not have sufficient transportation or public services and utilities.

It is likely that the proposed amendments result in additional units within the urban growth area, in close proximity to transportation and public services, however, historical development patterns indicate that ADUs are not a driver of rural development. Between January 1, 1996, and December 31, 2019, ADUs accounted for approximately 5% of the total dwellings sited in the rural area. It is unlikely that the amendments are going to change rural development patterns.

**Proposed measures to reduce or respond to such demand(s) are:**

Since this proposal is unlikely to directly or indirectly increase demands on transportation or public services and utilities, measures to reduce impacts are not applicable. However, the proposed code amendments include additional restrictions on the construction of ADUs in the rural area by prohibiting detached ADUs on rural lots that do not meet the prescriptive lot size set forth in SCC 30.23.030. Under current standards, the ADU prohibition applies only to substandard lots, which allows detached units much more freely throughout the rural area, including on many lots that are smaller than five acres such as in rural cluster subdivisions.

**7. Identify, if possible, whether the proposal may conflict with local, state, or federal laws or requirements for the protection of the environment.**

This non-project proposal does not conflict with any law or requirements to protect the environment.

# Accessory Apartments\_SEPA Checklist

Final Audit Report

2021-03-24

Created:	2021-03-24
By:	Tiffany Kelly (Tiffany.Kelly@co.snohomish.wa.us)
Status:	Signed
Transaction ID:	CBJCHBCAABAAI3salLf_L7etD8Wcinr6S-yVo9d8a5Z

## "Accessory Apartments\_SEPA Checklist" History

-  Document created by Tiffany Kelly (Tiffany.Kelly@co.snohomish.wa.us)  
2021-03-24 - 4:37:27 PM GMT- IP address: 207.183.1.30
-  Document emailed to Mitchell Brouse (mitchell.brouse@snoco.org) for signature  
2021-03-24 - 4:38:17 PM GMT
-  Email viewed by Mitchell Brouse (mitchell.brouse@snoco.org)  
2021-03-24 - 4:38:35 PM GMT- IP address: 23.103.200.254
-  Document e-signed by Mitchell Brouse (mitchell.brouse@snoco.org)  
Signature Date: 2021-03-24 - 4:39:29 PM GMT - Time Source: server- IP address: 75.6.179.203
-  Agreement completed.  
2021-03-24 - 4:39:29 PM GMT

## Accessory Dwelling Units

Index # - File Name: 1.0029 Accessory Dwelling Units\_DNS Postcard.pdf

# SEPA NOTIFICATION



**Notice is Hereby Given** that SNOHOMISH COUNTY PLANNING AND DEVELOPMENT SERVICES (PDS) has issued a Determination of Non-significance (DNS) for a non-project action.

**Description of Proposal:** Proposed non-project proposal to amend Snohomish County Code (SCC) Title 30 to update regulations related to accessory dwelling units (ADUs). Ordinance is titled:

**Project Proponent:** Snohomish County PDS. PDS determined that this non-project proposal will not have a probable significant adverse impact on the environment.

**Date of Issuance:** March 29, 2021

**Contact:** Mitchell Brouse, Senior Planner, (425) 388-5127, or [mitchell.brouse@snoco.org](mailto:mitchell.brouse@snoco.org).

**SEPA Comments Due:** This DNS is issued under WAC 197-11-340(2). The lead agency will not act on this proposal for 14 days from the issue date above. Comments must be submitted by 5:00 p.m., on April 12, 2021, to the responsible official at the address listed on the DNS.

Additional information regarding the proposed legislation is available at the County's website at: [www.snohomishcountywa.gov](http://www.snohomishcountywa.gov) **Keyword: Plans and Reports**, select **Environmental Documents**



**Snohomish County**

**Planning and Development Services**

3000 Rockefeller Ave., M/S 604

Everett, WA 98201-4046

(425) 388-3311

[www.snoco.org](http://www.snoco.org)

**Dave Somers**

*County Executive*

## **DETERMINATION OF NONSIGNIFICANCE**

**Proponent:** Department of Planning and Development Services  
Snohomish County Administration Building  
3000 Rockefeller Avenue, M/S 604  
Everett, WA 98201

**Description of Proposal:** Proposed non-project proposal to amend Snohomish County Code (SCC) Title 30 to update regulations related to accessory dwelling units (ADUs). Ordinance is titled:

RELATING TO GROWTH MANAGEMENT; REVISING ACCESSORY APARTMENT REGULATIONS; AMENDING SECTIONS IN CHAPTERS 30.22, 30.23, 30.24, 30.25, 30.26, 30.28, 30.31A, 30.35A, 30.41G, 30.66C AND SUBTITLE 30.9 OF THE SNOHOMISH COUNTY CODE

### Proposed Amendments

This is a non-project proposal to update Snohomish County Code (SCC) Title 30 to amend standards regulating the development of accessory dwelling units by allowing ADUs as a permitted use in all zoning districts that also allow single-family dwellings, permitting up to two ADUs on lots within the urban growth area, and eliminating superfluous regulations, while maintaining protections on rural growth and character.

**Lead Agency:** Snohomish County Department of Planning and Development Services

**Threshold Determination:** The lead agency for this proposal has determined that it does not have a probable significant adverse impact on the environment. An environmental impact statement (EIS) **IS NOT** required under RCW 43.21C.030(2)(c). This decision was made after review by Snohomish County of a completed environmental checklist and other information on file with this agency. This information is available for public review upon request.

This DNS is issued under WAC 197-11-340(2); the lead agency will not act on this proposal for 14 days from the date below. Comments must be submitted by April 12, 2021, to the responsible official at the address listed below.

**Appeals:** This DNS together with the subsequent legislative action by the County Council to amend the County Code may be appealed to the Central Puget Sound Growth Management Hearings Board. **THIS DNS MAY BE APPEALED ONLY WHEN SUCH APPEAL IS COMBINED WITH THE APPEAL OF THE UNDERLYING ACTION PURSUANT TO SCC 30.73.100. THE APPEAL MUST BE FILED WITHIN 60 DAYS OF THE PUBLISHED NOTICE OF ACTION ISSUED SUBSEQUENT TO THE FINAL DECISION BY THE COUNTY.** The Notice of Action describing the final decision by the County to pursue or not pursue the proposed action will be published in the County's paper of record. Any appeal must be filed with the Central Puget Sound Growth Management Hearings Board, at PO Box 40953 Olympia WA 98504-0953 within 60 days following publication in the paper, or as otherwise stated in the Notice of Action or provided by law.

For further information, contact Mitchell Brouse, Planning and Development Services, (425) 388-5127 or [Mitchell.Brouse@snoco.org](mailto:Mitchell.Brouse@snoco.org). Please include your full name and mailing address in any email comments.

**Responsible Official:** Barbara Mock

**Position/Title:** Director, Department of Planning and Development Services

**Address:** 3000 Rockefeller Avenue, M/S #604  
Everett, WA 98201-4046

*Barbara Mock*

Barbara Mock (Mar 24, 2021 10:04 PDT)

Barbara Mock, Director

**Date Issued:** March 29, 2021

**Date Published:** March 29, 2021

**Distribution List:** Attached



**Snohomish County**

**Planning and Development Services**

3000 Rockefeller Ave., M/S 604

Everett, WA 98201-4046

(425) 388-3311

[www.snoco.org](http://www.snoco.org)

**Dave Somers**

*County Executive*

## **SNOHOMISH COUNTY ENVIRONMENTAL CHECKLIST**

### **Purpose of Checklist**

The State Environmental Policy Act (SEPA), chapter 43.21C RCW, requires all governmental agencies to consider the environmental impacts of a proposal before making decisions. An environmental impact statement (EIS) must be prepared for all proposals with probable significant adverse impacts on the quality of the environment. The purpose of this checklist is to provide information on the impacts from this proposal (and to reduce or avoid impacts if possible) to help the agency decide whether an EIS is required.

### **A. Background**

#### **1. Name of proposed project:**

Proposed non-project proposal to amend Snohomish County Code (SCC) Title 30 to update regulations related to accessory dwelling units (ADUs).

#### **2. Name of applicant:**

Snohomish County, Department of Planning and Development Services.

#### **3. Address and phone number of applicant and contact person:**

Mitchell Brouse, Project Manager  
3000 Rockefeller, M/S 604  
Everett, WA 98201  
Phone: 425-388-5127  
Email: [mitchell.brouse@snoco.org](mailto:mitchell.brouse@snoco.org)

#### **4. Date checklist prepared:**

March 19, 2021



**5. Agency requesting checklist:**

Snohomish County, Department of Planning and Development Services

**6. Proposed timing or schedule (including phasing, if applicable):**

Planning Commission briefing: June 23, 2020

Planning Commission public hearing: July 28, 2020

County Council public hearing: Tentatively, April, 2021

**7. Do you have any plans for future additions, expansion, or further activity related to or connected with this proposal? If yes, explain.**

This proposal is for a non-project action to amend the regulations regarding the development of accessory dwelling units (ADUs), also referred to as accessory apartments. Site-specific actions may be proposed by private or public entities in the future, which will be reviewed for compliance with the regulations in effect at the time of application.

**8. List any environmental information you know about what has been prepared, or will be prepared, directly related to this proposal.**

This non-project proposal is consistent with the policies and goals of the adopted GMA Comprehensive Plan, which included an EIS, that was adopted on June 3, 2015. No additional environmental information or studies have been prepared for the proposed development regulations.

**9. Do you know whether applications are pending for governmental approvals of other proposals directly affecting the property covered by your proposal? If yes, explain.**

This is a non-project proposal, which affects the regulation accessory apartments within unincorporated Snohomish County. Project-specific proposals affecting unincorporated Snohomish County are under consideration at any given time.

**10. List any government approvals or permits that will be needed for your proposal, if known.**

Adoption by the Snohomish County Council is required for this non-project proposal.

**11. Give brief, complete description of your proposal, including the proposed uses and the size of the project and site. There are several questions later in this checklist that ask you to describe certain aspects of your proposal. You do not need to repeat those answers on this page.**

1. This non-project proposal will amend SCC 30.22.100, SCC 30.22.110, and SCC 30.22.120 to change accessory dwelling units from an administrative conditional use to a permitted use in all districts that also allow a single-family dwelling.
2. This non-project proposal will amend SCC 30.23.235 to eliminate the prohibition on accessory dwelling units on substandard lots and replace it with a prohibition on detached ADUs on rural lots that do not meet the minimum required lot area for the zone in which they are located.
3. This non-project proposal will amend SCC 30.25.020 and SCC 30.25.028 to eliminate perimeter landscaping requirements and buffer requirements for accessory dwelling units located in zones categorized as residential, multi-family, or commercial.
4. This non-project proposal will amend SCC 30.26.030 to update the number of parking spaces required for accessory dwelling units located in the urban zones.
5. This non-project proposal will amend SCC 30.28.010 to update the development standards for accessory dwelling units including adding standards for ADUs in the rural areas to protect rural character and limit sprawl.
6. This non-project proposal will amend chapter 30.91A SCC to add a definition for the term “accessory dwelling unit” and update the definitions of “accessory apartment, attached” and “accessory apartment, detached.”
7. This non-project proposal will amend chapters 30.22, 30.24, 30.31A, 30.35A, 30.41G, 30.66C, and 30.91D SCC to replace the term “accessory apartments” with the term “accessory dwelling units.”

**12. Location of the proposal. Give sufficient information for a person to understand the precise location of your proposed project, including a street address, if any, and section, township, and range, if known. If a proposal would occur over a range of area, provide the range or boundaries of the site(s). Provide a legal description, site plan, vicinity map, and topographic map, if reasonably available. While you should submit any plans required by the agency, you are not required to duplicate maps or detailed plans submitted with any permit applications related to this checklist. \_**

This non-project proposal affects all zones in the unincorporated portions of Snohomish County where single-family dwellings are a permitted use.

## **B. Environmental Elements**

### **1. Earth**

#### **a. General description of the site:**

(Circle one): **Flat, rolling, hilly, steep slopes, mountainous, other** all  
of the above \_\_\_\_\_

Lands within the jurisdiction of Snohomish County include a variety of terrain such as flat, rolling, hilly, and steep slopes. The lands that are proposed to be effected by this non-project proposal are that are located in the R-9600, R-8,400,

R-7,200, T, LDMR, MR, RD, RRT-10, R-5, CRC, F, F&R, A-10, MC, SA-1, RC, R-20,000, R-12,500, and WFB zones.

**b. What is the steepest slope on the site (approximate percentslope)?**

Slopes in excess of 100% can be found within the jurisdiction of Snohomish County.

**c. What general types of soils are found on the site (for example, clay, sand, gravel, peat, muck)? If you know the classification of agricultural soils, specify them and note any agricultural land of long-term commercial significance and whether the proposal results in removing any of these soils.**

A range of soil types are found within the jurisdiction of Snohomish County. This non-project proposal will not remove soils in agricultural lands designated as of long-term commercial significance.

**d. Are there surface indications or history of unstable soils in the immediate vicinity? If so, describe.**

Certain areas within Snohomish County have a history of surface instability associated with periods of heavy rainfall. Other areas have a history of more deep-seated instability associated with landslide activity. In particular, flooding includes mudslides which are caused by overflow of waters of rapid runoff of surface waters.

**e. Describe the purpose, type, total area, and approximate quantities and total affected area of any filling, excavation, and grading proposed. Indicate source of fill.**

As a non-project proposal, no filling or grading is proposed. Any future site-specific development or land use proposal not exempted by WAC 197-11-800 or SCC 30.61.035 would be subject to a separate SEPA review, which would include review of any proposed grading or filling activity.

**f. Could erosion occur as a result of clearing, construction, or use? If so, generally describe.**

As a non-project action, no erosion will occur as a direct result of this proposal. Any future site-specific development or land use proposal not exempted by WAC 197-11-800 or SCC 30.61.035 would be subject to a separate SEPA review, which would include review of any proposed clearing and construction that might result in erosion.

**g. About what percent of the site will be covered with impervious surfaces after project construction (for example, asphalt or buildings)?**

As a non-project action, no impervious surface coverage will occur as a result of this proposal. Any future site-specific development or land use proposal not exempted by WAC 197-11-800 or SCC 30.61.035 would be subject to a separate SEPA review, which would include review of any proposed impervious surface area.

**h. Proposed measures to reduce or control erosion, or other impacts to the earth, if any:**

As a non-project proposal, no erosion reduction or control measures are proposed or required. Future site-specific development or land use action not exempted by WAC 197-11-800 or SCC 30.61.035 would be subject to project level SEPA and regulatory review and would require the implementation of applicable County regulations to reduce or control erosion or other impacts to the earth.

**2. Air**

**a. What types of emissions to the air would result from the proposal during construction, operation, and maintenance when the project is completed? If any, generally describe and give approximate quantities if known.**

As a non-project action, no emissions to air will occur as a result of this proposal.

**b. Are there any off-site sources of emissions or odor that may affect your proposal? If so, generally describe.**

Not applicable.

**c. Proposed measures to reduce or control emissions or other impacts to air, if any:**

As a non-project proposal, no measures to reduce or control emissions are required or proposed. Future site-specific development or land use action not exempted by WAC 197-11-800 or SCC 30.61.035 would be subject to project level SEPA and regulatory review and would require the implementation of applicable County regulations to reduce or control emissions or other impacts to air, if any.

**3. Water**

**a. Surface Water:**

**1) Is there any surface water body on or in the immediate vicinity of the site (including year-round and seasonal streams, saltwater, lakes, ponds, wetlands)? If yes, describe type and provide names. If appropriate, state what stream or river it flows into.**

There are several streams, seasonal streams, and bodies of water located within Snohomish County.

- 2) Will the project require any work over, in, or adjacent to (within 200 feet) the described waters? If yes, please describe and attach available plans.**

As a non-project action, this proposal will not require any work in, or adjacent to, the described waters. Future site-specific development or land use actions not exempted by WAC 197-11-800 or SCC 30.61.035 would be subject to project level SEPA and regulatory review and would require the implementation of applicable County regulations to reduce or control activities near surface water bodies, if any.

- 3) Estimate the amount of fill and dredge material that would be placed in or removed from surface water or wetlands and indicate the area of the site that would be affected. Indicate the source of fill material.**

As a non-project proposal, no fill or dredge material will be placed or removed from surface water or wetlands.

- 4) Will the proposal require surface water withdrawals or diversions? Give general description, purpose, and approximate quantities if known.**

As a non-project proposal, no surface water withdrawals or diversion will be required.

- 5) Does the proposal lie within a 100-year floodplain? If so, note location on the site plan.**

Not applicable because this is a non-project action.

- 6) Does the proposal involve any discharges of waste materials to surface waters? If so, describe the type of waste and anticipated volume of discharge.**

As a non-project action, no discharges of waste materials to surface waters will occur as a result of this proposal.

**b. Ground Water:**

- 1) Will groundwater be withdrawn from a well for drinking water or other purposes? If so, give a general description of the well, proposed uses and approximate quantities withdrawn from the well. Will water be discharged to groundwater? Give general description, purpose, and approximate quantities if known.**

As a non-project proposal, no groundwater will be withdrawn or discharged. However, future site-specific projects may propose ADUs that are connected to a well, resulting in groundwater withdrawal. The amendments to Snohomish County Code that are proposed by this not-project proposal require that all ADUs have both physical and legal access to water. Requiring legal availability will prohibit permit issuance unless the proposed ADU has legal access to a water right. This provision will protect groundwater resources from being overdrawn as a result of this proposal.

- 2) Describe waste material that will be discharged into the ground from septic tanks or other sources, if any (for example: Domestic sewage; industrial, containing the following chemicals; agricultural; etc.). Describe the general size of the system, the number of such systems, the number of houses to be served (if applicable), or the number of animals or humans the system(s) are expected to serve.**

As a non-project action, no waste material will be discharged from septic tanks or other sources as a result of this proposal. Future development or land use actions not exempted by WAC 197-11-800 or SCC 30.61.035 that would likely result in discharges from stormwater runoff would be subject to project-level SEPA and regulatory review.

Further, the amendments proposed by this non-project proposal require that applicants looking to construct an ADU provide documentation that the proposed sewage system is capable of handling the additional demand placed on the system by the proposed ADU.

**c. Water runoff (including stormwater):**

- 1) Describe the source of runoff (including storm water) and method of collection and disposal, if any (include quantities, if known). Where will this water flow? Will this water flow into other waters? If so, describe.**

As a non-project action, no runoff will occur as a result of this proposal. Any future site-specific development or land use action proposal would be subject to a separate SEPA and development permit review, which would address runoff management.

- 2) Could waste materials enter ground or surface waters? If so, generally describe.**

As a non-project action no runoff will occur as a result of this proposal. Any future site-specific development or land use action proposal not exempted by WAC 197-11-800 or SCC 30.61.035 would be subject to a separate SEPA and development permit review, which would address runoff management.

**d. Does the proposal alter or otherwise affect drainage patterns in the vicinity of the site? If so, describe.**

As a non-project action, no drainage patterns will be affected as a result of this proposal. Any future site-specific development or land use proposal not exempted by WAC 197-11-800 or SCC 30.61.035 would be subject to a separate SEPA and permit review, which would address drainage.

**e. Proposed measures to reduce or control surface, ground, and runoff water, and drainage pattern impacts, if any:**

As a non-project proposal, no measures are proposed or required to reduce impacts to surface or groundwater. Any future site-specific development or land use proposal not exempted by WAC 197-11-800 or SCC 30.61.035 would be subject to a separate SEPA and permit review.

**4. Plants**

**a. Check the types of vegetation found on the site:**

deciduous tree: alder, maple, aspen, other

evergreen tree: fir, cedar, pine, other

shrubs

grass

pasture

crop or grain

Orchards, vineyards or other permanent crops.

wet soil plants: cattail, buttercup, bullrush, skunk cabbage, other

water plants: water lily, eelgrass, milfoil, other

other types of vegetation

All types of the above vegetation occur in various locations throughout the county.

**b. What kind and amount of vegetation will be removed or altered?**

As a non-project action, no vegetation will be removed as a direct result of this proposal. Any future site-specific development project not exempted by WAC 197-11-800 or SCC 30.61.035 would be subject to a separate SEPA evaluation of any proposed vegetation removal or alteration.

**c. List threatened and endangered species known to be on or near the site.**

Threatened and endangered vegetation species can be found in various locations throughout Snohomish County.

**d. Proposed landscaping, use of native plants, or other measures to preserve or enhance vegetation on the site, if any:**

As a non-project action, no measures to preserve or enhance vegetation are required for this proposal. Any future site-specific development or land use action not exempted by WAC 197-11-800 or SCC 30.61.035 would be subject to a separate SEPA and permit review, which would include review of any proposed landscaping or measures to preserve or enhance vegetation on the site. The U.S Fish and Wildlife Services provides listing for ESA species under its jurisdiction; and the Washington State Department of Fish and Wildlife provides listing for priority habitat species under its jurisdiction. These resources are consulted for mitigation of impacts from site-specific proposals under consideration.

**e. List all noxious weeds and invasive species known to be on or near the site.**

All types of noxious weeds and invasive species occur throughout the county.

**5. Animals**

**a. List any birds and other animals which have been observed on or near the site or are known to be on or near the site.**

Birds: **hawk, heron, eagle, songbirds, other:** \_\_\_\_\_  
Mammals: **deer, bear, elk, beaver, other:** \_\_\_\_\_  
Fish: **bass, salmon, trout, herring, shellfish, other:** \_\_\_\_\_

All of the above animal species may be found in various locations throughout the county including those areas affected by this non-project proposal.

**b. List any threatened and endangered species known to be on or near the site.**

Threatened and endangered bird, animal and fish species can be found in various locations throughout Snohomish County.

**c. Is the site part of a migration route? If so, explain.**

Yes. Wildlife species do migrate through the county, but as a non-project action, this proposal will not impact migratory species.

**d. Proposed measures to preserve or enhance wildlife, if any:**

As a non-project proposal, no measures to preserve or enhance wildlife are required or proposed. Any future site-specific development project not exempted by WAC 197-11-800 or SCC 30.61.035 would be subject to a separate SEPA review, which would include review and implementation of measures to preserve or enhance wildlife, if any. The



U.S Fish and Wildlife and National Marine Fisheries Services provide listing for ESA species under their jurisdiction; and the Washington State Department of Fish and Wildlife provides listing for sensitive species under its jurisdiction. These resources are consulted for mitigation of impacts from site-specific proposals under consideration.

- e. **List any invasive animal species known to be on or near the site.**

All types of invasive animal species exist throughout the county.

## 6. Energy and Natural Resources

- a. **What kinds of energy (electric, natural gas, oil, wood stove, solar) will be used to meet the completed project's energy needs? Describe whether it will be used for heating, manufacturing, etc.**

As a non-project proposal, energy will not be consumed.

- b. **Would your project affect the potential use of solar energy by adjacent properties? If so, generally describe.**

As a non-project action, there will be no impact on solar energy as a result of this proposal.

- c. **What kinds of energy conservation features are included in the plans of this proposal? List other proposed measures to reduce or control energy impacts, if any:**

As a non-project action, energy conservation features are not applicable to this proposal. Any future site-specific development project not exempted by WAC 197-11-800 or SCC 30.61.035 would be subject to a separate SEPA review, which would include review and implementation of measures to reduce or control energy impacts, if any.

## 7. Environmental Health

- a. **Are there any environmental health hazards, including exposure to toxic chemicals, risk of fire and explosion, spill, or hazardous waste, that could occur as a result of this proposal? If so, describe.**

As a non-project action, no environmental health hazards will result as a consequence of this proposal.

- 1) **Describe any known or possible contamination at the site from present or past uses.**

As a non-project proposal, this is not applicable. Any future site-specific development project not exempted by WAC 197-11-800 or SCC 30.61.035

would be subject to a separate SEPA review, which would include identification of known or possible contamination, if any.

- 2) **Describe existing hazardous chemicals/conditions that might affect project development and design. This includes underground hazardous liquid and gas transmission pipelines located within the project area and in the vicinity.**

As a non-project proposal, this is not applicable. Any future site-specific development project not exempted by WAC 197-11-800 or SCC 30.61.035 would be subject to a separate SEPA review, which would include identification existing hazardous chemicals/conditions, if any.

- 3) **Describe any toxic or hazardous chemicals that might be stored, used, or produced during the project's development or construction, or at any time during the operating life of the project.**

As a non-project proposal, this is not applicable. Any future site-specific development project not exempted by WAC 197-11-800 or SCC 30.61.035 would be subject to a separate SEPA review, which would include a review of toxic or hazardous chemicals stored, used, or produced during the project's development or construction, or at any time during the operating life of the project, if any.

- 4) **Describe special emergency services that might be required.**

As a non-project action, no special emergency services are required by this proposal.

- 5) **Proposed measures to reduce or control environmental health hazards, if any:**

As a non-project action, no measures to reduce or control environmental health hazards are required for this proposal. Any future site-specific development project not exempted by WAC 197-11-800 or SCC 30.61.035 would be subject to a separate SEPA review, which would include review and implementation of measures to reduce or control environmental health hazards, if any.

**b. Noise**

- 1) **What types of noise exist in the area which may affect your project (for example: traffic, equipment, operation, other)?**

This non-project proposal will not be affected by noise.

- 2) What types and levels of noise would be created by or associated with the project on a short-term or a long-term basis (for example: traffic, construction, operation, other)? Indicate what hours noise would come from the site.**

This non-project proposal will not generate noise.

- 3) Proposed measures to reduce or control noise impacts, if any:**

As a non-project proposal, no measures to reduce or control noise impacts are required or proposed. Any future site-specific development project not exempted by WAC 197-11-800 or SCC 30.61.035 would be subject to a separate SEPA review, which would include review and implementation of measures to reduce or control noise impacts, if any.

## **8. Land and Shoreline Use**

- a. What is the current use of the site and adjacent properties? Will the proposal affect current land uses on nearby or adjacent properties? If so, describe.**

This non-project proposal includes amendments to Snohomish County Code that affect all areas located in the R-9600, R-8,400, R-7,200, T, LDMR, MR, RD, RRT-10, R-5, CRC, F, F&R, A-10, MC, SA-1, RC, R-20,000, R-12,500, and WFB zones. Any future site-specific development project not exempted by WAC 197-11-800 or SCC 30.61.035 would be subject to a separate SEPA review, which would include review and implementation of measures to reduce or control impacts to adjacent properties, if any.

- b. Has the project site been used as working farmlands or working forest lands? If so, describe. How much agricultural or forest land of long-term commercial significance will be converted to other uses as a result of the proposal, if any? If resource lands have not been designated, how many acres in farmland or forest land tax status will be converted to nonfarm or nonforest use?**

This non-project proposal pertains to all areas of unincorporated Snohomish County that are located in the R-9600, R-8,400, R-7,200, T, LDMR, MR, RD, RRT-10, R-5, CRC, F, F&R, A-10, MC, SA-1, RC, R-20,000, R-12,500, and WFB zones. These areas include property that may have been, may be, or is currently being used as working farmlands or working forestlands.

- 1) Will the proposal affect or be affected by surrounding working farm or forest land normal business operations, such as oversize equipment access, the application of pesticides, tilling, and harvesting? If so, how:**

As a non-project action, this proposal will not affect or be affected by surrounding working farm or forest land operations.

**c. Describe any structures on the site.**

Not applicable to this non-project proposal.

**d. Will any structures be demolished? If so, what?**

As a non-project action, no structures will be demolished as a result of this proposal.

**e. What is the current zoning classification of the site?**

This non-project proposal pertains to the R-9600, R-8,400, R-7,200, T, LDMR, MR, RD, RRT-10, R-5, CRC, F, F&R, A-10, MC, SA-1, RC, R-20,000, R-12,500, and WFB zoning classifications found in Snohomish County Code title 30.

**f. What is the current comprehensive plan designation of the site?**

This non-project proposal pertains to the Urban Low Density Residential (ULDR), Urban Medium Density Residential (UMDR), Urban High Density Residential (UHDR), Urban Horticulture (UH), Local Forest (LF), Low Density Rural Residential (LDRR), Rural Residential-10 (RR-10), Rural Residential-5 (RR-5), Rural Residential (RR), Rural Residential RD (RR-RD), Clearview Rural Commercial (CRC), Upland Commercial Farmland (UCF), Riverway Commercial Farmland (RCF), Recreational Land (RL), and Commercial Forest (CF) land use designations.

**g. If applicable, what is the current shoreline master program designation of the site?**

Not applicable to this non-project action.

**h. Has any part of the site been classified as a critical area by the city or county? If so, specify.**

Not applicable to this non-project action.

**i. Approximately how many people would reside or work in the completed project?**

As a non-project proposal, this is not applicable.

**j. Approximately how many people would the completed project displace?**

As a non-project proposal, this is not applicable.

**k. Proposed measures to avoid or reduce displacement impacts, if any:**

As a non-project action, no measures to avoid or reduce displacement impacts are required by this proposal.

**l. Proposed measures to ensure the proposal is compatible with existing and projected land uses and plans, if any:**

As a non-project proposal, the proposed code amendments are compatible with the land uses and plans.

**m. Proposed measures to reduce or control impacts to agricultural and forest lands of long-term commercial significance, if any:**

As a non-project action, no impacts to agricultural and forest lands of long-term commercial significance would occur as a result of this proposal. This proposed non-project action does not change existing regulations or protections relating to agricultural and forest lands of long-term commercial significance, however, it does alter standards for the development of ADUs on some such properties.

**9. Housing**

**a. Approximately how many units would be provided, if any? Indicate whether high, middle, or low-income housing.**

As a non-project action, no housing units would be provided directly by this proposal. However, because the amendments reduce the barriers to construction of ADUs and allow two ADUs per urban lot, this proposal could result in additional housing units being constructed in lower density urban areas.

**b. Approximately how many units, if any, would be eliminated? Indicate whether high, middle, or low-income housing.**

As a non-project action, no housing units would be eliminated by this proposal.

**c. Proposed measures to reduce or control housing impacts, if any:**

As a non-project action, no measures to reduce or control impacts to housing are required or proposed. However, the proposed amendments include standards intended to minimize the impacts from the construction of new ADUs.

**10. Aesthetics**

**a. What is the tallest height of any proposed structure(s), not including antennas; what is the principal exterior building material(s) proposed?**

As a non-project proposal this is not applicable.

**b. What views in the immediate vicinity would be altered or obstructed?**

As a non-project proposal this is not applicable.

**c. Proposed measures to reduce or control aesthetic impacts, if any:**

As a non-project action, no measures to reduce or control aesthetic impacts are required or proposed. However, the proposed non-project action would adopt architectural and design standards to ensure that all ADUs developed are compatible with the development on the property.

**11. Light and Glare**

**a. What type of light or glare will the proposal produce? What time of day would it mainly occur?**

As a non-project action, no light or glare will occur as a result of this proposal.

**b. Could light or glare from the finished project be a safety hazard or interfere with views?**

As a non-project proposal this is not applicable.

**c. What existing off-site sources of light or glare may affect your proposal?**

Not applicable to this non-project proposal.

**d. Proposed measures to reduce or control light and glare impacts, if any:**

As a non-project action, no measures to reduce or control light and glare impacts are required or proposed.

**12. Recreation**

**a. What designated and informal recreational opportunities are in the immediate vicinity?**

The non-project action affects land in unincorporated Snohomish County, some of which may have opportunities for hunting, fishing, bird watching and other recreational activities.

**b. Would the proposed project displace any existing recreational uses? If so, describe.**

This non-project proposal will not displace any existing recreational uses.

- c. Proposed measures to reduce or control impacts on recreation, including recreation opportunities to be provided by the project or applicant, if any:**

As a non-project action, no measures to reduce or control impacts on recreation are proposed or required. Any future site-specific development proposal not exempted by WAC 197-11-800 or SCC 30.61.035 would be subject to a separate SEPA review, which would include review and implementation of measures to reduce or control impacts on recreation, including recreation opportunities to be provide by the project or applicant, if any

### **13. Historic and cultural preservation**

- a. Are there any buildings, structures, or sites, located on or near the site that are over 45 years old listed in or eligible for listing in national, state, or local preservation registers ? If so, specifically describe.**

Not applicable to this non-project proposal.

- b. Are there any landmarks, features, or other evidence of Indian or historic use or occupation? This may include human burials or old cemeteries. Are there any material evidence, artifacts, or areas of cultural importance on or near the site? Please list any professional studies conducted at the site to identify such resources.**

Not applicable to this non-project action. Future development proposals may be conditioned or subject to further review on a site-specific basis under Chapter 30.32D SCC – Historic and Archaeological Resources.

- c. Describe the methods used to assess the potential impacts to cultural and historic resources on or near the project site. Examples include consultation with tribes and the department of archeology and historic preservation, archaeological surveys, historic maps, GIS data, etc.**

Not applicable to this non-project action. Future development proposals may be conditioned or subject to further review on a site-specific basis under Chapter 30.32D SCC – Historic and Archaeological Resources.

- d. Proposed measures to avoid, minimize, or compensate for loss, changes to, and disturbance to resources. Please include plans for the above and any permits that may be required.**

As a non-project action, no measures to reduce or control impacts on resources are proposed or required. Any future site-specific development proposal not exempted by WAC 197-11-800 or SCC 30.61.035 would be subject to a separate SEPA review, which would include review and implementation of measures to reduce or control impacts on resources.

### **14. Transportation**

- a. Identify public streets and highways serving the site or affected geographic area and describe proposed access to the existing street system. Show on site plans, if any.**

Various highways and state routes and local streets service Snohomish County.

- b. Is the site or affected geographic area currently served by public transit? If so, generally describe. If not, what is the approximate distance to the nearest transit stop?**

Various transit services exists in Snohomish County.

- c. How many additional parking spaces would the completed project or non-project proposal have? How many would the project or proposal eliminate?**

As a non-project proposal, no parking spaces are proposed or eliminated. Future site-specific development must meet the minimum parking requirements as mandated by Chapter 30.26 of the Snohomish County Code.

- d. Will the proposal require any new or improvements to existing roads, streets, pedestrian, bicycle or state transportation facilities, not including driveways? If so, generally describe (indicate whether public or private).**

Not applicable to this non-project proposal.

- e. Will the project or proposal use (or occur in the immediate vicinity of) water, rail, or air transportation? If so, generally describe.**

Not applicable to this non-project proposal.

- f. How many vehicular trips per day would be generated by the completed project or proposal? If known, indicate when peak volumes would occur and what percentage of the volume would be trucks (such as commercial and nonpassenger vehicles). What data or transportation models were used to make these estimates?**

This non-project action will not directly generate any vehicular trips per day. Any future site specific development or land use proposal not exempted by WAC 197-11-800 or SCC 30.61.035 would be subject to a separate SEPA and permit review, which would include review of traffic issues.

- g. Will the proposal interfere with, affect or be affected by the movement of agricultural and forest products on roads or streets in the area? If so, generally describe.**

As a non-project action, the proposal will not interfere with, affect, or be affected by the movement of agricultural and forest products on roads or streets. Any



future development or land use proposal w not exempted by WAC 197-11-800 or SCC 30.61.035 would be subject to a separate SEPA and permit review, which will include review of impacts interfering, affecting, or resulting from the movement of agricultural and forest products on roads or streets.

**h. Proposed measures to reduce or control transportation impacts, if any:**

As a non-project action, no measures to reduce or control transportation are proposed or required. Any future site-specific development or land use action not exempted by WAC 197-11-800 or SCC 30.61.035 would be subject to a separate SEPA and concurrency review, which would include implementation of measures to reduce or control any transportation impacts.

**15. Public Services**

**a. Would the project result in an increased need for public services (for example: fire protection, police protection, public transit, healthcare, schools, other)? If so, generally describe.**

As a non-project action, this proposal will not result in an increased need for public services.

**b. Proposed measures to reduce or control direct impacts on public services, if any.**

As a non-project proposal, no measures to reduce or control impacts on public services are proposed or required.

**16. Utilities**

**a. Circle utilities currently available at the site:**

Electricity, natural gas, water, refuse service, telephone, sanitarysewer, septic system, other \_\_\_\_\_

Not applicable to this non-project proposal.

**b. Describe the utilities that are proposed for the project, the utility providing the service, and the general construction activities on the site or in the immediate vicinity which might be needed.**

As a non-project proposal, no utilities are proposed or required.

**C. Signature**

The above answers are true and complete to the best of my knowledge. I understand that the lead agency is relying on them to make its decision.

***Mitchell Brouse***

Signature:

[Mitchell Brouse \(Mar 24, 2021 11:39 CDT\)](#)

Mitchell Brouse, Project Manager

Senior Planner, Planning and Development Services

Date Submitted: March 24, 2021

## **D. Supplemental sheet for non-project actions**

### **1. How would the proposal be likely to increase discharge to water; emissions to air; production, storage, or release of toxic or hazardous substances; or production of noise?**

The proposal has the potential to increase stormwater runoff on development sites, however standards are proposed that will limit such increases. The proposed code changes will not likely contribute to the production, storage, or release of toxic or hazardous substances; or the production of noise.

#### **Proposed measures to avoid or reduce such increases are:**

This non-project action does not propose to change any existing regulations for stormwater management, and any development projects will be required to meet all applicable regulations, including implementation of low impact development strategies whenever feasible. Future site-specific land activity not exempted by WAC 197-11-800 or SCC 30.61.035 would be subject to project level environmental analysis and threshold determination.

Beyond that, the proposed standards require that detached ADUs in the rural area be located within 100 feet of the primary dwelling and share a driveway with that dwelling, which limiting the impervious surface associated with detached ADUs in the rural area. Further, the proposed amendments require that applicants looking to construct an ADU provide documentation that the proposed sewage system is capable of handling the additional demand placed on the system by the proposed ADU. Which will protect from an increase in discharges of toxic or hazardous substances.

### **2. How would the proposal be likely to affect plants, animals, fish, or marine life?**

As a non-project action the proposal is not likely to impact animals, fish, or marine life. Future development will be subject to the county's critical area regulations under Title 30, which include provisions to protect streams, wetlands, and wildlife.

#### **Proposed measures to protect or conserve plants, animals, fish, or marine life are:**

The County's critical areas regulations regulate development in environmentally sensitive areas. Future site-specific land activity not exempted by WAC 197-11-800 or SCC 30.61.035 would be subject to project level environmental analysis and threshold determinations.

Future site-specific land activity will be required to meet all relevant development regulations, including open space, landscaping and tree canopy regulations, which help to protect and conserve plants and habitat.

### **3. How would the proposal be likely to deplete energy or natural resources?**

The proposal would not likely deplete energy or natural resources. The proposed amendments do not alter the underlying standards that restrict development in natural resource areas. The prescriptive minimum lot size is 20 acres in the F-Forestry zone, 10 acres in the A-10-Agricultural and MC-Mineral Conservation zones, and 200,000 square feet in the F&R-Forestry and Recreation zone. Under the proposed amendments, detached ADUs would only be allowed on lots that exceed the minimum lot size.

**Proposed measures to protect or conserve energy and natural resources are:**

As a non-project action, no measures to conserve energy or natural resources are necessary for this proposal. Future site-specific land activity not exempted by WAC 197-11-800 or SCC 30.61.035 would be subject to project-level environmental analysis and threshold determinations.

- 4. How would the proposal be likely to use or affect environmentally sensitive areas or areas designated (or eligible or under study) for governmental protection; such as parks, wilderness, wild and scenic rivers, threatened or endangered species habitat, historic or cultural sites, wetlands, floodplains, or prime farmlands?**

The proposed code amendments would not likely affect environmentally sensitive areas because vegetation removal is prohibited in critical areas and critical area buffers. As a non-project action, this proposal is unlikely to directly affect environmentally sensitive areas or areas designated (or eligible or under study) for government protection.

**Proposed measures to protect such resources or to avoid or reduce impacts are:**

The County's critical areas regulations regulate development in environmentally sensitive areas. Future site-specific land activity not exempted by WAC 197-11-800 or SCC 30.61.035 would be subject to project level environmental analysis and threshold determinations.

- 5. How would the proposal be likely to affect land and shoreline use, including whether it would allow or encourage land or shoreline uses incompatible with existing plans?**

The proposal is not likely to affect shoreline use. The County's Shoreline Management Plan regulates development in the shoreline designations. This proposal does not encourage incompatible shoreline uses. The proposal is consistent with allowed land uses on lots that allow single-family dwellings and only affects the development of accessory dwellings units, which are allowed only as accessory to a single-family dwelling.

**Proposed measures to avoid or reduce shoreline and land use impacts are:**

The proposed code amendments are consistent with shoreline regulations, so

measures to reduce impacts are not applicable. Future site-specific development proposals in the shoreline environment are subject to County development regulations implementing the Shoreline Management Program, Chapters 30.44 and 30.67 SCC.

Future site-specific development proposals are subject to County development regulations to protect plants, trees, and mitigate stormwater runoff.

**6. How would the proposal be likely to increase demands on transportation or public services and utilities?**

This non-project proposal is unlikely to directly or indirectly increase demands on transportation or public services and utilities. It is unlikely that this proposal will result in a significant amount of additional dwelling units in areas that do not have sufficient transportation or public services and utilities.

It is likely that the proposed amendments result in additional units within the urban growth area, in close proximity to transportation and public services, however, historical development patterns indicate that ADUs are not a driver of rural development. Between January 1, 1996, and December 31, 2019, ADUs accounted for approximately 5% of the total dwellings sited in the rural area. It is unlikely that the amendments are going to change rural development patterns.

**Proposed measures to reduce or respond to such demand(s) are:**

Since this proposal is unlikely to directly or indirectly increase demands on transportation or public services and utilities, measures to reduce impacts are not applicable. However, the proposed code amendments include additional restrictions on the construction of ADUs in the rural area by prohibiting detached ADUs on rural lots that do not meet the prescriptive lot size set forth in SCC 30.23.030. Under current standards, the ADU prohibition applies only to substandard lots, which allows detached units much more freely throughout the rural area, including on many lots that are smaller than five acres such as in rural cluster subdivisions.

**7. Identify, if possible, whether the proposal may conflict with local, state, or federal laws or requirements for the protection of the environment.**

This non-project proposal does not conflict with any law or requirements to protect the environment.





# Accessory Apartments\_DNS with Signature Block

Final Audit Report

2021-03-24

Created:	2021-03-24
By:	Tiffany Kelly (Tiffany.Kelly@co.snohomish.wa.us)
Status:	Signed
Transaction ID:	CBJCHBCAABAAaPZ_wQN_3XjTNdhCywE655eiQ7Re326p

## "Accessory Apartments\_DNS with Signature Block" History

-  Document created by Tiffany Kelly (Tiffany.Kelly@co.snohomish.wa.us)  
2021-03-24 - 5:01:06 PM GMT- IP address: 207.183.1.30
-  Document emailed to Barbara Mock (barb.mock@snoco.org) for signature  
2021-03-24 - 5:01:35 PM GMT
-  Email viewed by Barbara Mock (barb.mock@snoco.org)  
2021-03-24 - 5:04:36 PM GMT- IP address: 23.103.201.254
-  Document e-signed by Barbara Mock (barb.mock@snoco.org)  
Signature Date: 2021-03-24 - 5:04:53 PM GMT - Time Source: server- IP address: 207.183.1.30
-  Agreement completed.  
2021-03-24 - 5:04:53 PM GMT